













**FRONTISPIECE**

General View of Panama-Pacific International Exposition by Artificial Illumination.  
See lecture by W. D'A. Ryan, page 547.

*green*

# ILLUMINATING ENGINEERING PRACTICE

LECTURES

ON ILLUMINATING ENGINEERING

DELIVERED AT THE

UNIVERSITY OF PENNSYLVANIA

PHILADELPHIA, SEPTEMBER 20 TO 28, 1916

UNDER THE JOINT AUSPICES OF  
THE UNIVERSITY AND THE

ILLUMINATING ENGINEERING  
SOCIETY

McGRAW-HILL BOOK COMPANY, INC.  
239 WEST 39TH STREET. NEW YORK

---

LONDON: HILL PUBLISHING CO., LTD.  
6 & 8 BOUVERIE ST., E. C.

1917

volume, were delivered at the University of Pennsylvania between the dates September 20 and September 28 inclusive, by men peculiarly qualified by training and experience to present the most advanced treatment of illumination problems.

It is worthy of record here that there were 180 subscriptions to the entire course and that in addition 59 tickets to individual lectures were sold. Supplementing the lectures an exhibit was arranged which exemplified modern methods of illumination and illustrated modern lighting appliances. An inspection tour was also organized in connection with the lectures, including visits to places of interest to lighting men, in Pittsburgh, Washington, Philadelphia, Atlantic City, New York, Boston, Schenectady, Buffalo, Cleveland and Chicago.

EDWARD P. HYDE.

---

#### THE INCEPTION OF THE 1916 ILLUMINATING ENGINEERING COURSE

In considering special activities when undertaking the Presidency of the Illuminating Engineering Society in the summer of 1915, I conceived the idea of a course of lectures on illuminating engineering which would be supplementary to the course held at The Johns Hopkins University in 1910, and which would emphasize the practical rather than the theoretical aspect of the subject. Later it developed that members of the faculty of the University of Pennsylvania had discussed a like project. Happily these two ideas, of independent origin, were brought together before the Council of the Illuminating Engineering Society, and the lecture course was duly consummated. The result has been very gratifying to the Illuminating Engineering Society. The value of the course was demonstrated at the time of its presentation. This book is expected to extend that value materially.

CHARLES P. STEINMETZ.

## OPENING EXERCISES

The lecture course followed immediately upon the adjournment of the 1916 Annual Convention of the Illuminating Engineering Society, which was held in Philadelphia. On the evening preceding the first lecture, and following the closing session of the Convention, a meeting was held in the auditorium of the Museum of the University of Pennsylvania, to which meeting the public was invited. The following interesting program was carried out:

Address—CHARLES P. STEINMETZ,  
President Illuminating Engineering Society.

Address—EDGAR F. SMITH,  
Provost University of Pennsylvania.

Address—EDWARD P. HYDE,  
Chairman 1910 and 1916 I.E.S. Committees on  
Lectures.

Popular Lecture—Subject, "Controlled Light"  
WM. A. DURGIN,  
Director Illuminating Engineering Society.

A large and enthusiastic audience greeted the distinguished speakers. Representations from the faculty and undergraduate body of the University, from the membership of the Illuminating Engineering Society, and from the local lighting organizations, combined to make the occasion auspicious.

*Expression of Appreciation Tendered by the Illuminating Engineering Society to the University of Pennsylvania*

The very able and cordial coöperation of the faculty and staff of the University of Pennsylvania which contributed largely to the success of the Illuminating Engineering Lecture Course prompted the Council of the Illuminating Engineering Society to forward to Provost Smith of the University an engrossed "appreciation" couched in the following terms:

The Council of the Illuminating Engineering Society expresses

its appreciation of the courteous coöperation of the Provost and Faculty of the University of Pennsylvania in the joint organization and conduct of the Illuminating Engineering Lecture Course, September 21st to 28th, 1916.

(Signed) G. H. STICKNEY,  
*General Secretary.*

(Signed) WM. J. SERRILL,  
*President.*

December 14, 1916.

## CONTENTS

	PAGE
PREFACE . . . . .	v
COMMITTEE ON LECTURES . . . . .	x
Illumination Units and Calculations . . . . .	1
By A. S. McALLISTER.	
The Principles of Interior Illumination, Parts I and II . . . . .	37
Committee: J. R. CRAVATH, WARD HARRISON, R. ff. PIERCE.	
The Principles of Exterior Illumination . . . . .	77
By LOUIS BELL.	
Modern Photometry . . . . .	99
By CLAYTON H. SHARP.	
Recent Developments in Electric Lighting Appliances . . . . .	131
By G. H. STICKNEY.	
Recent Developments in Gas Lighting Appliances . . . . .	165
By ROBERT ff. PIERCE.	
Modern Lighting Accessories . . . . .	183
By W. F. LITTLE.	
Light Projection: Its Applications . . . . .	213
By E. J. EDWARDS and H. H. MAGDSICK.	
The Architectural and Decorative Aspects of Lighting . . . . .	253
By GUY LOWELL.	
Color in Lighting . . . . .	267
By M. LUCKIESH.	
Church Lighting Requirements . . . . .	297
By E. G. PERROT.	
The Lighting of Schools, Libraries and Auditoriums . . . . .	307
By F. A. VAUGHN.	
The Lighting of Factories, Mills and Workshops . . . . .	337
By C. E. CLEWELL.	
The Lighting of Offices, Stores and Shop Windows . . . . .	363
By NORMAN MACBETH.	
The Lighting of the Home . . . . .	395
By H. W. JORDAN.	
The Lighting of Streets (Part I) . . . . .	415
By PRESTON S. MILLAR.	
Street Lighting (Part II) . . . . .	461
By C. F. LACOMBE.	
Railway Car Lighting . . . . .	493
By GEORGE H. HULSE.	
The Lighting of Yards, Docks and Other Outside Works . . . . .	513
By J. L. MINICK.	
Sign Lighting . . . . .	535
By L. G. SHEPARD.	

curves and can be converted into "light curves" only after making proper modifications in accordance with certain well-defined solid geometrical relations. It seems appropriate to give emphasis to this statement by defining the solid geometrical relations referred to, which are equally as simple as plane geometrical or trigonometrical relations.

### SOLID GEOMETRICAL RELATIONS

Of the several space geometrical relations with which an illuminating engineer should be familiar, by far the most important, and happily the simplest, is that existing between the external area or zonal area of a sphere and its diameter or zonal width. This relation is one of direct proportion. That is to say, the external area

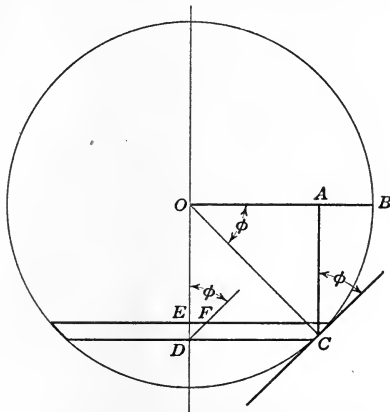

Fig. 1.—Spherical geometrical relations.

of a zone of any chosen sphere varies directly with the width of the zone, and the total external area is that of a zone having a width equal to the diameter of the sphere.

In almost all cases of application to illumination problems, one is interested in the relative values rather than the actual values of the various zonal areas and the above mentioned proportion is all that he needs to take into consideration. However, one can determine the actual as well as the relative values with extreme simplicity by means of certain plane geometrical or trigonometrical relations applied to the sphere.

In Fig. 1, which represents a sphere cut along a vertical plane through the center  $O$ , the zone of infinitesimal vertical width  $ED$ , along the diameter, has an external area represented by the sloping

width at  $C$  multiplied by the circumference of the zonal circle passing horizontally through  $C$ . Now the circumference of the horizontal circle through  $C$  bears to that of the horizontal circle through  $B$  (that is, the "great circle" of the sphere), the relation of  $\cos \phi$  to 1. Likewise the sloping width of the zone at  $C$  bears to the vertical width  $ED$  the inverse ratio, 1 to  $\cos \phi$ .

Since these two ratios, one the inverse of the other, are to be multiplied together in determining the zonal area, it is obvious that the external area of the zone having a width  $ED$  along the diameter is equal to the product of this width by the circumference of the "great circle." Similarly the total external area of the sphere is found by multiplying the sphere diameter (= total width of all zones) by the circumference of the great circle; or is equal to  $d \times \pi d = \pi d^2 = 4\pi r^2$  where  $d$  is the diameter and  $r$  the radius of the sphere.

Familiarity with the above fundamental spherical (space) geometrical relations is absolutely essential to a proper understanding of the significance of the curves showing the space distribution of the candle-power of light sources; to the derivation or interpretation of diagrams showing the light from sources whose candle-power curves are known, and to the solution of problems relating to plane surface or extended surface sources.

It is noteworthy in this connection that the modern tendency is away from point sources, and point-source candle-power methods of calculation, towards extended source and lumen-output calculating methods, so that the importance of becoming familiar with space geometrical relations is ever on the increase.

#### UNIT SOLID ANGLE—THE STERADIAN

Although the illuminating engineer is seldom called upon to make use of solid angular dimensions expressed in terms of any unit of solid angular measurement, because almost all of the calculations in which he is interested can be based on ratios rather than actual values of solid angles, yet it may at times be found convenient to refer to some solid angular measurement in terms of a unit of measurement. Two distinct units have been employed for this purpose, one represented by the whole sphere and the other by a value  $1 \div 4\pi$  as large. For the former no special name has been standardized, while to the latter the name "steradian" is applied.



From its definition it will be seen that any zone on a sphere having a diametrical width such that  $W = d \div 4\pi$ , where  $d$  is the diameter of the sphere, will subtend a solid angle of one steradian, and that  $4\pi = 12.57$  + steradians equal one sphere in solid angular measurement.

Since the external surface of a sphere of unit radius is equal to  $4\pi$  units of area, it follows that a steradian is an angle having such a value as to subtend unit area on the surface of a sphere of unit radius, or an area equal numerically to the radius squared on a sphere of any dimension whatsoever expressed in any unit of length or area.

It is sometimes stated that the solid angle subtended by a chosen area when viewed from a chosen position can be calculated in steradians by dividing the numerical value of the area by the square of the distance between the point selected and the area. This statement is correct only when applied to an area every infinitesimal element of which occupies the same distance from the point of observation; that is, when the area lies on the circumference of a sphere having its center at the point chosen.

#### RELATION BETWEEN LIGHT AND CANDLE-POWER DISTRIBUTION

In order to present most clearly the exact significance of the candle-power curve; explain most readily the diagram for showing the distribution and summation of the light flux (lumens) from the source, and to give proper emphasis to the necessary distinction between candle-power distribution and light distribution use will be made of the curve of candle-power of a source giving light in only one hemisphere.

In order definitely to fix ideas it will be assumed that the maximum candle-power of the source is 100 and that the candle-power decreases uniformly according to a cosine function of the angle of vision to zero at 90 degrees from the position of maximum candle-power. The curve showing the distribution of candle-power of such a source (which could be for example, an infinitesimal plane radiating in accordance with the "cosine law" of space distribution of candle-power) is represented in Fig. 2.

Assume now that the source is placed at the center of a hollow sphere of unit radius the interior surface of which is illuminated by the source, as indicated in Fig. 2. The illumination on each elementary area of the surrounding sphere will at each point be numeric-

ally equal to the candle-power of the source when observed from that point—expressed in foot-candles if the radius of the sphere is one foot; in meter-candles if the radius is one meter, etc. Hence to determine the lumens incident upon any chosen section of the surrounding sphere it is necessary merely to multiply the area of that section by the mean candle-power of the source effective over that section.

It is convenient not only for present purposes but also for purposes of subsequent comparisons, to express the area of sections of the surrounding sphere in terms of the zones cut off by various angles below (and above) the horizontal.

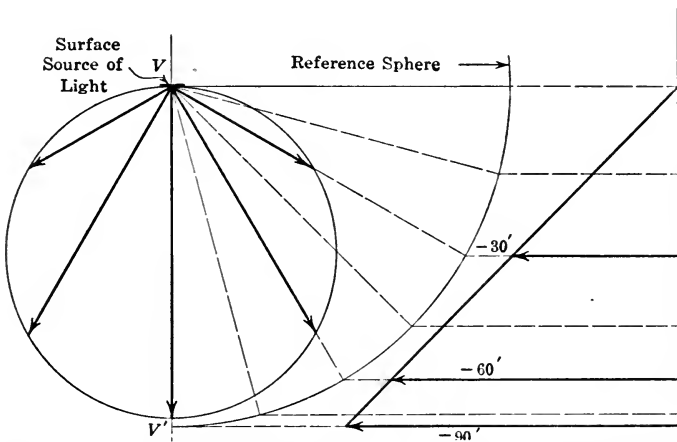

Figs. 2 and 3.—Space distribution of candle-power and light flux from infinitesimal surface source.

It should here be observed that, for sake of convenience in derivation and explanation, the angles indicated herein are measured (in both the plus and the minus direction) from the horizontal plane, whereas in actual curves of candle-power distribution the angles of elevation are “counted positively from the nadir as zero to the zenith as 180 degrees.” That is to say, whereas in the curves herein shown the vertical angles are measured through zero from minus 90 degrees to plus 90 degrees, it is the more usual plan to make all measurements in the positive direction from zero plotted at the bottom of the curve to 180 degrees at the top.

The zonal areas measured from the horizontal plane are as follows:

Zonal angle from horizontal	Zonal width sine of angle	Zonal area $2\pi$ zonal width	Max. C. P. of zone
0-15	0.259	1.63	25.9
0-30	0.500	3.14	50.0
0-45	0.7070	4.44	70.7
0-60	0.866	5.44	86.6
0-75	0.969	6.06	96.6
0-90	1.000	6.28	100.0

Zone	Area	Candle-Power			Lumens
		Max.	Min.	Mean	Area $\times$ CP
0-30	3.14	50.0	00.0	25.0	78.5
30-60	2.30	86.6	50.0	68.3	157.1
60-90	0.84	100.0	86.6	93.3	78.4
Total.....	6.28	.....	....	Total....	314.0

The vertical widths of the separate zones are represented by the vertical line at the extreme right in Fig. 3. Along this line have been erected certain perpendiculars for representing the candle-power values over each part of the zone width. The product of the candle-power at each point by the zone area at that point which bears the constant relation of  $2\pi \div 1$  to the vertical width of each zone, gives the lumens over that zone—to a certain scale. Obviously the area of the triangular figure at the right in Fig. 3 represents (to a scale involving the candle-power scale, the distance scale and the constant  $2\pi$ ) the total lumens radiated by the source. From this figure, known as the Rousseau diagram, the lumens effective over any chosen zone can be computed at once from the intercepted area on the diagram. This is not an approximate, but an absolutely exact method of calculation. Any errors involved in using the method can be attributed to inaccuracies in measuring or plotting the candle-power or in determining the areas from the diagram; that is, to inexactness in carrying out the method rather than to the method itself.

By using the Rousseau diagram merely as an aid in visualizing the problem and resorting to plane or spherical geometrical or trigonometrical calculations for actual determinations, one can often eliminate all inaccuracies other than those inherent in the photometric testing of the lighting source.

If the candle-power had been uniform throughout the lower hemisphere at a value equal to the actual maximum of 100 the total number of lumens would have been 628, or just twice the actual value. Similarly, if the uniform candle-power of 100 has been active throughout both the upper and the lower hemisphere, the lumens output from the source would have totalled 1256, or four times the actual value determined above by slide-rule computation. The mathematically exact result would be,

$$\text{Area} \times c.p. = 4\pi \times 100 = 1256.64 +.$$

The exact ratio between the total lumens produced by the lighting source having the candle-power distribution indicated in Fig. 2, and the lumens that would be produced by a source giving uniform candle-power in all directions equal to the maximum in Fig. 2, is  $1 \div 4$ . Obviously this ratio, which is called the "spherical reduction factor," in any practical case depends upon the shape of the candle-power distribution curve, becoming indefinitely small in the case of a concentrated beam and reaching a maximum of 1.0 in the case of a source of uniform candle-power such as a spherical surface source.

It may be well at this point to call attention to the fact that the "mean spherical candle-power" of a surface source of any shape whatsoever is equal to one-fourth of the product of the effective radiating area by the maximum candle-power of an (infinitesimal) unit area of the source, provided only that each infinitesimal area radiates in space according to the cosine law of space-distribution and all infinitesimal areas have the same maximum value of candle-power. The total effective candle-power in any chosen direction observed at any chosen position from such a source is equal to the product of the candle-power per unit area by the "projected area" of the source as viewed from the direction (and exact position) chosen. These facts will be discussed in greater detail later in connection with the subjects of "brightness" "output" and "appearance."

On account of the fact that such curves as those shown in Fig. 2 are often loosely referred to as "light-distribution" curves, rather than "candle-power-distribution" curves, certain misconceptions have been produced in the minds of persons not familiar with the exact physical significance of the geometrical representation of the photometric relations.

In order to lay proper emphasis on the distinction that must be

made between "light distribution" and "candle-power distribution," a comparison will be made with the actual distribution of light in each vertical zone (as accurately shown by the Rousseau diagram of Fig. 3) and the distribution of light which would exist if the curve of Fig. 2 were in reality a "light distribution" rather than a "candle-power distribution" curve. This curve is reproduced in Fig. 4, where it is treated as representing "light distribution," and on the basis of this interpretation the Rousseau diagram of Fig. 5, has been constructed by the methods already explained. A comparison of the *incorrect* diagram of Fig. 5, with the *correct* diagram of Fig. 3 will serve to show the inaccuracy in treating a "candle-power distribution" curve as a "light distribution" curve.

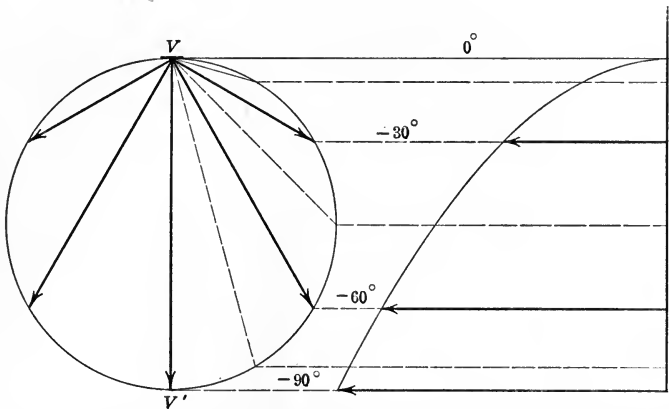

Figs. 4 and 5.—Space distribution of light from an assumed source and corresponding flux summation diagram.

#### CANDLE POWER DISTRIBUTION FROM CYLINDRICAL AND SPHERICAL SURFACE SOURCES

In Fig. 6, the smaller double circles show the space distribution of candle power around an infinitesimal cylindrical surface source having a vertical axis. In Fig. 7, the elliptical area is the Rousseau diagram showing the light flux produced over various zones of the sphere surrounding the light source, as explained above.

In Fig. 6, the large central circle shows the candle-power distribution around a spherical surface source; the corresponding Rousseau diagram is represented by the rectangular area in Fig. 7. The separate curves of Fig. 6 have been so drawn that the rectangular area of Fig. 7 is equal to the elliptical area of the same figure. That

is, the light output from the cylindrical surface has been made equal to the light output from the spherical surface.

It will be recalled, from well-known trigonometrical and geometrical relations, that the area of an ellipse is equal to  $\pi/4$  times the product of the major and minor axes, whereas that of a rectangle is equal to the product of the major and minor sides. It follows therefore that the minor side of the rectangle in Fig. 7 is equal to

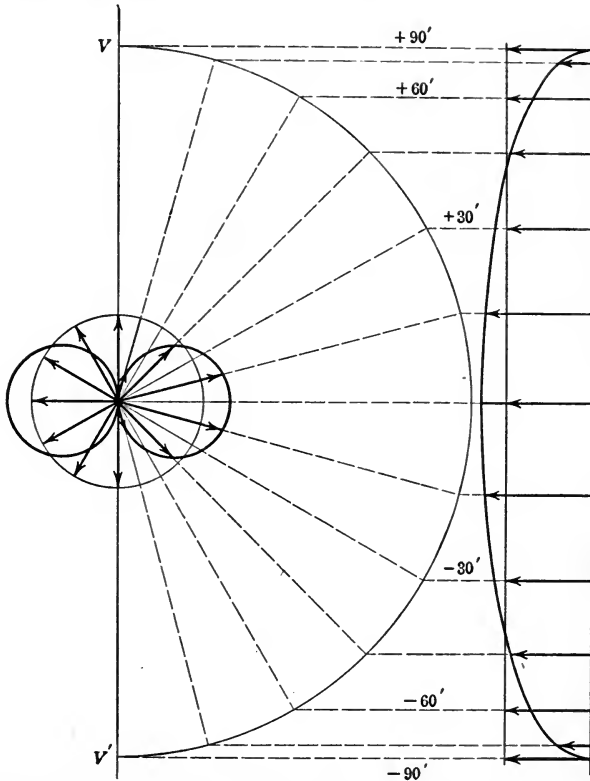

Figs. 6 and 7.—Space distribution of candle-power from infinitesimal cylindrical and spherical sources and corresponding flux summation diagrams.

$\pi/4$  times the minor axis of the ellipse, and hence the maximum (uniform) candle-power of the spherical surface source is equal to  $\pi/4$  times the maximum (horizontal) candle-power of the cylindrical surface source in Fig. 6. That is to say, the "spherical reduction factor" of a cylindrical surface source is equal to  $\pi/4 = 0.7854$ . This is the value usually assigned to a so-called "line-source," which has no existence in reality, its nearest approach in practice

being the cylindrical surface of a lamp filament having an inappreciable diameter.

#### SPACE REPRESENTATION OF CANDLE-POWER DISTRIBUTION

By means of models representing solids of revolution of the candle-power curves about the axis of reference one can obtain a better idea of the real significance of the space distribution of the candle-power than can be obtained from the flat candle-power curve which must in any event be interpreted as showing merely a cross-sectional view of such a space-model. In interpreting a candle-power distribution model care must be exercised in giving significance to the quantities represented. Special emphasis must be placed on the fact that neither the volumetric content of the model nor the superficial area has any immediate relation to the flux of light from the source giving the candle-power indicated by the model. A striking illustration of this fact is afforded by a comparison of the centrally located candle-power circle in Fig. 6 with the completely displaced candle-power circle in Fig. 2.

As already shown by means of the Rousseau diagrams of Fig. 7 and Fig. 3, the flux produced by the source giving the circular candle-power curve of Fig. 6 is exactly equal to that produced by the source giving the circular candle-power curve of Fig. 2, and hence the solid of revolution of Fig. 6 represents exactly the same amount of flux as does the solid of revolution of Fig. 2.

The diameter of the circle in Fig. 2 is exactly twice as great as that in Fig. 6; the superficial area of the solid of revolution of Fig. 2 is four times that of Fig. 6, and its volumetric content is eight times as large.

A certain percentage of the volumetric content or superficial area of any chosen solid of revolution represents the same percentage of the total flux of light from the source only in the limiting cases of uniform candle-power in all directions as shown by the centrally located circle of Fig. 6 or of a section of the sphere cut vertically throughout the whole depth.

From the two illustrations chosen above, it will be observed that even when the scale of candle-power is defined, the total flux represented by a given solid of revolution is known only when the exact location of the light source within the sphere is known. With the source at the center, the sphere represents the maximum of light flux; when the source is at the surface (as in Fig. 2) the light flux

has only one-half of the maximum value, all other quantities, dimensions and scales remaining the same.

#### SPHERICAL SURFACE: THE SO-CALLED "POINT"-SOURCE

For many purposes it has been found convenient to refer to a source of light as though it were a "point" (that is, without dimensions) and by certain mathematical transformations certain equations applicable exclusively to surface sources have been treated as though they related to true point-sources. When dealing with illumination effects at a distance, no measurable errors are involved in such assumptions and transformations, but when one attempts to define the "brightness" or appearance of the source to the eye on the basis of an assumed point-source, the assumptions are found to be at conflict with the most significant physical fact, which is that the brightness is a function of the area, whereas points (even an infinite number of them) are devoid of dimensions or area.

By treating the so-called "point-source," not as a true point but as an infinitesimal surface having all of the physical characteristics of a surface source the mathematical difficulties can be overcome, but by far the simplest and most satisfactory method is to treat the source initially, finally and all the time, as a surface source having true surface source characteristics.

Consider, therefore, a spherical surface source of unit radius (1 cm.) emitting 100 candle-power uniformly in all directions. The total output from the source will be  $4\pi \times 100 = 1257$  lumens. The superficial area of the source is  $4\pi r^2 = 12.57$  sq. cm., and hence the output is equal to 100 lumens per square centimeter. At any appreciable distance from the source the "projected area" of the source viewed from this distance is equal to  $\pi r^2 = 3.14$  sq. cm. and hence the "apparent candle-power per unit of projected area" is  $100 \div 3.14 = 31.9$  a value which in the past has been called "brightness," but no name has been adopted for designating the unit. For the unit quantity "apparent output" from the source expressed in "apparent lumens per sq. cm." the term "lambert" has been adopted. This term is applicable equally to the "brightness" (or appearance to the eye) of any surface whether radiating, transmitting, or reflecting, and whether or not it acts as a perfectly diffusing surface, but the unit is defined by, and receives its magnitude from, the appearance to the eye of "a perfectly diffusing surface radiating or reflecting one lumen per sq. cm."



As is well known, according to the so-called "inverse square law" the illumination (or luminous flux density) on a plane at any chosen distance from a "point-source" varies inversely with the distance from the source. If it were possible to obtain a true point-source, it would be possible to produce infinite illumination by bringing the plane within an infinitesimal distance from the source. With a spherical surface source the "inverse square" law holds true provided only that the distance from the source is measured from the center thereof. In this case the minimum distance from the source is equal to the radius of the sphere. With a spherical surface source 1 cm. in radius producing 100 c.p. uniformly in all directions the maximum illumination (at minimum distance) is equal to  $100 \div r^2 = 100$  lumens per sq. cm. This means that the maximum possible illumination in lumens per sq. cm. is equal to the "brightness" of the source expressed in "lamberts." This relation holds true for surface sources of all kinds and shape, being absolutely fundamental. Any assumption that would lead to results contrary thereto can be said not to be in accord with the physical fact.

In order always to have before one a correct mental picture of the true physical conditions of lighting sources, it is best always to assume that the so-called "point-source" is in reality a spherical surface source (having finite dimensions), and to base all calculations on the surface source rather than point-source conception. That is to say, it is not necessary to employ the "point-source conception" in order to take advantage of the "inverse square law" and similar relations developed and employed on the basis of the assumed "point-source," because the same relations are applicable even more accurately and completely to the spherical surface source. Moreover, there are certain relations between the output density of the surface sources and the illumination (flux density) produced on surfaces illuminated thereby, which can be utilized immediately when all calculations are based on the surface source conception but which must be ignored in effect when the point-source conception is used. This fact is becoming of increasing importance as the indirect or semi-indirect system of lighting is being substituted for the direct.

#### FLUX-SUMMATION ON MEAN SPHERICAL CANDLE-POWER DIAGRAM

Reference has already been made to the Rousseau diagram for representing by means of an area the total flux produced by a light

source of which the candle-power distribution curve is known. As a matter of actual practice in illumination calculations use may be said always to be made for the purpose indicated of either the Rousseau diagram or some one of several modifications thereof that have been developed for eliminating the necessity of a planimeter for determining the area or its equivalent.

Figs. 8 and 9 have been drawn to show one of the methods employed for representing the equivalent of an area by means of a straight line. The irregular curve  $XbeY$  of Fig. 8 is a candle-power

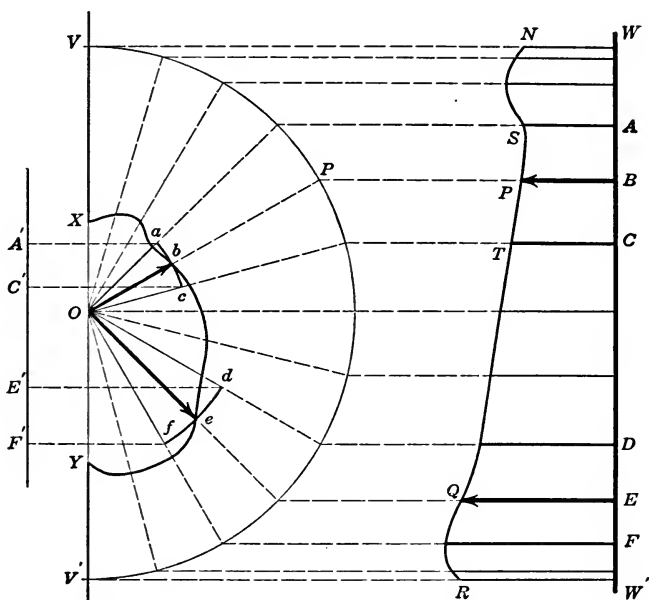

Figs. 8 and 9.—Linear and area representations of zonal flux.

distribution curve of which Fig. 9 is the corresponding Rousseau, or flux-summation, diagram. Consider the small area  $ABCTPS$  of Fig. 9. If such a section be so selected that its mean width is equal to  $PB$  then the small area  $ABCTPS$  is equal to the product of  $AC$  (the height) by  $PB$  (the width). The problem is to select some one line which, by geometrical construction, is proportional to the product of  $AC$  and  $PB$ . In Fig. 8 such a line is shown by  $A'C'$ , which by construction, bears to  $AC$  (of Fig. 9) the direct ratio of  $Ob$  to  $OP$  (of Fig. 8). That is to say, it is proportional directly to the area  $ABCTPS$ , the proportionality constant

being dependent upon the linear candle-power scale and the diameter of  $V'$  the circle of reference, or rather the enclosing sphere.

The summation of all the various part-areas of Fig. 9 as indicated by  $A'C'$ ,  $E'F'$ , etc., of Fig. 8, would produce a single linear dimension directly proportional to the total area of Fig. 9; that is, directly proportional to the total flux from the source of which the irregular curve of Fig. 8 shows the space distribution of the candle-power.

One can easily define the proportionality constant by applying the method here outlined to the determination of the total flux from the candle-power curve of a "spherical surface" source producing equal candle-power in all directions. It will be seen at once that the total of the vertical lengths (corresponding to  $A'C'$  and  $E'F'$ , etc.) would then equal twice the length chosen to represent the uniform candle-power of the "spherical surface" source; now the total flux is equal to  $4\pi I$  whereas the summation length is  $2 I$  and hence the proportionality constant is  $2\pi$ .

That is to say, independent in every respect of the irregularities of the candle-power curve, the linear summation method outlined above gives at once a value equal (if sufficiently small sections are selected for summation) to twice the mean spherical candle-power of the source, measured on the candle-power scale, and this value multiplied by  $2\pi$  equals (with the same degree of accuracy) the total flux from the source expressed in lumens.

It will be noted that, contrary to the relations involved in the Rousseau diagram, the diameter of the circle (or sphere) of reference cancels out from the proportionality constant in the linear summation of Fig. 8, whereas it appears as a direct factor in the area summation of Fig. 9.

#### LINEAR SUMMATION BY GRAPHICAL CONSTRUCTION

In Fig. 11 is reproduced the candle-power curve of an infinitesimal cylindrical surface source of which the Rousseau flux diagram (elliptical) is shown in Fig. 12, identical except as to dimensions with the elliptical diagram in Fig. 7. In Fig. 10 is shown a graphical method for adding together the vertical linear equivalents of the separate 30 degree areas in the Rousseau diagram of Fig. 12, the equivalents in each case being determined by the geometrical method already outlined in connection with Fig. 8. It will be noted that the 30-degree, 60-degree and 90-degree angle lines have been so transposed, while retaining their equivalent lengths, that the corre-

sponding vertical distances are directly added one to the other to produce at once the total length of  $QQ'$ , which (according to the proportionality constant derived above) is equivalent to twice the mean spherical candle-power represented by the candle-power distribution curve of Fig. 11 or the Rousseau diagram of Fig. 12. The linear summation diagram briefly outlined in connection with Fig. 10 was developed by Dr. A. E. Kennelly, past president of the Illuminating Engineering Society, and is known as the Kennelly Diagram.

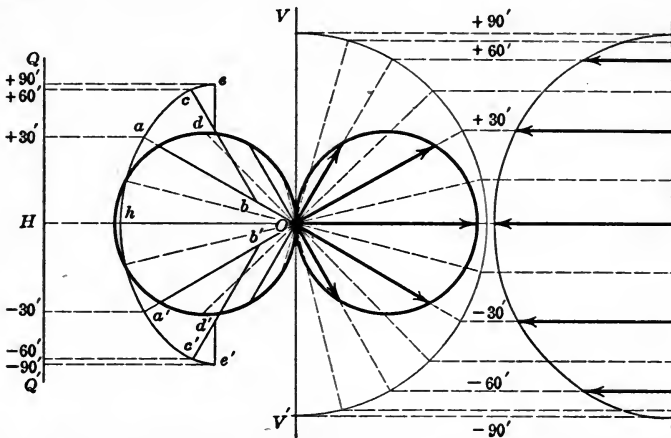

Figs. 10, 11, and 12.—Kennelly linear summation diagram; candle-power curve of cylindrical surface source; Rousseau area summation diagram.

### ABSORPTION-OF-LIGHT METHOD OF CALCULATION

One of the most convenient and an absolutely reliable method of calculation in illumination problems is that based on the law of conservation. According to this law the total flux (lumens) of light absorbed by the illuminated surfaces within any chosen enclosure of any size, shape or character is exactly equal to the total amount of flux (lumens) produced by the sources of the lumination. This law is fundamental and calculations based upon it give absolutely accurate results when the assumptions as to absorption, etc., are correct. That is to say, by adding together the value of the lumens separately absorbed by the various surfaces illuminated one obtains at once an exact measure of the lumens produced by the sources of light.

In order to determine the absorbed flux, it is necessary to know only the value of the incident flux and the absorption coefficient;

the product of these two represents accurately the lumens absorbed. Any error found in applying this method is to be attributed to the inability to determine either the value of the incident flux, or the absorption coefficient, or both, but not to the method itself.

For example, assume a room 25 ft. wide, 80 ft. long, 10 ft. high having a white ceiling with an absorption coefficient of 0.20; light walls with an absorption of 0.50; and a dark floor with an absorption of 0.90, to be so lighted that the incident illumination on the ceiling is 1 foot-candle, that on the walls 2-foot candles and on the floor 3 foot-candles. The following summation shows the amount of lumens absorbed:

	Area	Incident		Absorption	
	Sq. ft.	Ft. C.	Flux	Coef.	Flux
Ceiling.....	2000	1	2000	0.20	400
Walls.....	2100	2	4200	0.50	2100
Floor.....	2000	3	6000	0.90	5400

Total lumens absorbed = 7900.

Total mean spherical candle-power equals  $7900 \div 4\pi = 630$ .

This method is not approximate; it is absolutely exact. However, it should not be assumed that results in practice can be obtained with such ready facility as here indicated, because the absorption coefficients of ceiling, wall and floor materials are not known to a high degree of accuracy; various surfaces in addition to those here considered intercept and absorb much of the light, and the light is not uniformly distributed over the various surfaces. In regard to the last mentioned limitation it is worthy of note that the mere lack of uniformity in the distribution of light flux does not affect the accuracy of the absorption method, provided only that the true mean effective values of the incident illumination and of the absorption coefficient are assumed in each case.

The actual distribution of the incident flux can be approximated by means of some of the point-by-point methods of calculations, while the absorption coefficient must be based on the results of tests relating to the materials composing the absorbing surfaces. Values for such coefficients will be given in connection with other lectures dealing with the practical application of the methods of calculation herein described.

INTER-REFLECTIONS BETWEEN WALLS, CEILING AND FLOOR

Some idea concerning the bearing of reflection upon illumination can be gained readily from a brief study of the values derived from the above absorption problem.

The total incident flux on the ceiling, walls and floor equal  $2000 + 4200 + 6000 = 12,200$  lumens, whereas the lighting units are required to produce only 7900 lumens. The "mean effective absorption coefficient" of the room as a whole is, therefore,  $7900 \div 12,200 = 0.65$ . Of the total of 12,200 lumens incident upon the surfaces only 7900 come directly from the lamps,  $12,200 - 7900 = 4300$  lumens being attributable to inter-reflection between the surfaces.

Since only 2000 lumens are directed toward the ceiling (where 400 are absorbed and 1600 are reflected), whereas 6000 are directed toward the floor, it is apparent at once that the room selected is lighted by lamps which produced considerably more light in the lower than in the upper hemisphere; that is to say use is not made of the indirect system of lighting.

For sake of comparison, consider now the same room with the same absorption coefficients with the same total amount of incident flux upon the floor and walls but with such an amount directed toward the ceiling that the reflection therefrom equals the amount absorbed by the floor. In other words assume that, in effect, use is made of the "totally indirect" system—so far as the ceiling and floor are concerned.

The light flux reflected from the ceiling (with its 0.20 absorption = 0.80 reflection) must equal the 5400 lumens absorbed by the floor. Hence,  $5400 \div 0.80 = 6750$  equals the flux incident upon the ceiling. The tabulation will then be as follows:

	Area		Incident		Absorption	
	Sq. ft.	Flux	Ft. C.	Coef.	Flux	
Ceiling.....	2000	6750	3.37	0.20	1350	
Walls.....	2100	4200	2.00	0.50	2100	
Floor.....	2000	6000	3.00	0.90	5400	

Total lumens absorbed = 8850.

Total mean spherical candle-power  $8850 \div 4\pi = 705$ .

The total incident flux is equal to  $6750 + 4200 + 6000 = 16,950$  lumens, as compared with the former 12,200 lumens. Thus with

an increase of 11.9 per cent. in the candle-power of the lighting units, there is an increase of  $16,950 - 12,200 = 4750$  or 39 per cent. in the total incident flux in the room, with an increase of  $1350 - 400 = 950$  or 237 per cent. in the ceiling illumination.

In referring above to the change in the system of lighting equipment use was made of the term "totally indirect," in order to concentrate ideas on the immediate problem at hand rather than to describe the system actually required to produce the results indicated. With only 6750 lumens incident upon the ceiling which absorbs 1350 lumens, and a total of 4200 lumens incident upon the walls which absorb 2100 lumens, it is evident that the lighting units must supply considerable flux directly to the walls, and hence a "totally indirect" system of lighting would not produce the results required.

As already stated, in actual practice conditions are not so readily defined as assumed above, and the absorption method cannot be applied practically with the degree of simplicity that might be inferred from the above examples, but it can be looked upon as a most reliable check upon the more complicated methods of calculation and as an invaluable aid in solving problems connected with the illuminating of reflecting surfaces, investigating quantitatively the effect of inter-reflection between surfaces, and ascertaining the limits in the distribution of light flux between illuminated surfaces.

#### UTILIZATION FACTOR

In actual practical problems in illumination design it has been found quite convenient to make use of the direct relations between the so-called "total lumens utilized" and the lumens produced by the lighting sources, because the former can be considered to be the known quantity and the latter the unknown quantity in one phase of the practical illumination problem. The "lumens utilized" are assumed to be equal to the mean illumination (in, say, foot-candles) over the reference plane (say 30 in. above the floor) multiplied by the area of the floor (in square feet). The ratio between this quantity of lumens to the lumens produced by the source is called the "utilization factor," or "coefficient of utilization."

Referring to the two examples given above it will be seen that (if the illumination on the reference plane be assumed to be equal to that at the floor level) the utilization factor in the so-called "direct lighting" problem would be  $6000 \div 7900 = 0.76$ , whereas in the "indirect" problem it would be  $6000 \div 8850 = 0.68$ .

A study of the above problems in the light of the above definition will show that the "utilization factor" depends on not only the system of lighting and the absorption by the ceiling and walls but also on the absorption by the floor. The fact of the matter is that with highly reflecting floor, walls and ceiling the "utilization factor" would have a value greater than unity. This condition would seldom be reached in practice but would be closely approached in the case of a dining-room decorated in light colors, with a wide expanse of table linen and light floor covering. The value of the utilization factor depends upon the character of the lighting units, relative dimensions of the room, color and material of the ceiling, walls and floor. Utilization factors, as determined by actual tests under service conditions, will be discussed fully in other lectures, and need not be dwelt upon herein.

#### ILLUMINATION BY DAYLIGHT

Mention has already been made of the simple solution of problems that would otherwise prove quite complex by means of certain solid angular relations. This statement applies with particular force to problems relating to the illumination from either artificial or natural sky-light through either ceiling or side-wall windows.

In view of the fact that as a lighting source the sky is located at an indefinite, if not infinite, distance from the objects illuminated, it is obvious at once that resort cannot be had to the method of calculation based upon the so-called "inverse-square law." For purposes of calculation the sky can best be considered as an extended surface source of undefined shape at an indefinite distance from and completely surrounding the observer, being visible (except for local obstructions) throughout the upper hemisphere above the horizontal plane occupied by the observer. The first and most important step is to establish the relation between the illumination produced at any chosen point by such a source and the solid angle subtended by the source when viewed from that point; or rather first to show that the solid angular relations are in strict agreement with the "inverse-square law" and that by basing the calculations exclusively on the former the latter may be eliminated.

Referring to Fig. 13, consider the perfectly general case of a small section ( $dA$ ) of a surface lighting source of any shape or inclination ( $\alpha$ ) situated at any distance ( $R$ ) from any chosen point ( $P$ ). Let  $c$  be the normal emitting density (here used as "apparent candle-



power per unit area") of this source. The illumination produced at point  $P$ , from the inverse square and cosine laws, is,

$$\beta A = c \frac{(dA) \cos \alpha}{R^2} \quad (1)$$

Consider now the illumination that would be produced at the same point  $P$ , by a surface source ( $da$ )—at the circumference of the imaginary enclosing sphere—subtending the same solid angle as

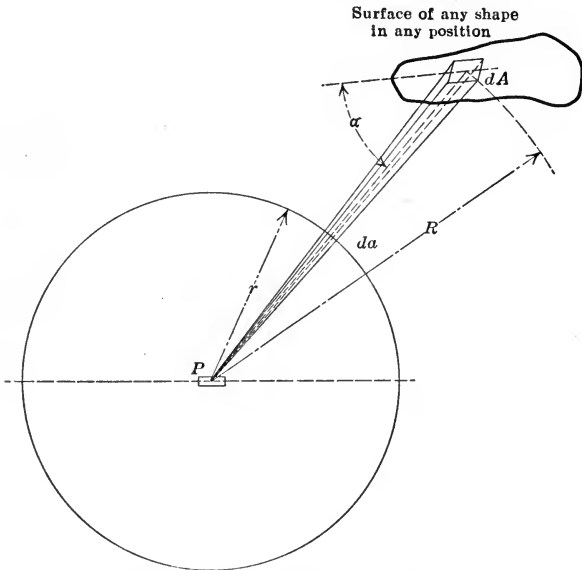

Fig. 13.—Photometric relations based on equality of solid angles.

( $dA$ ) and having an equal normal emitting density  $c$ . The illumination at the central point,  $P$ , would be

$$\beta a = \frac{c(da)}{r^2}. \quad (2)$$

From simple geometrical relations, the correctness of which will be appreciated at once from a glance at Fig. 13, it is seen that the areas ( $da$ ) and ( $dA$ ) bear to each other such a ratio that

$$(da) = \frac{r^2}{R^2}(dA) \cos \alpha \quad (3)$$

Combining equations (3) and (2) and comparing the result with equation (1), there is obtained

$$\beta a = \frac{c(dA) \cos \alpha}{R^2} = \beta A \quad (4)$$

Equation (4) shows that when dealing with surface lighting sources (such as the sky, artificial windows, or indirect lighting systems) the illumination at any chosen point is fully defined when the emitting density of the source and the solid angle subtended by the source as viewed from the point chosen are known. Upon this relation can be based some extremely simple graphical solutions of problems relating to illumination by daylight or by surface lighting sources in general.

From the relations derived above it will be seen that in calculating the illumination produced by a surface source it is unnecessary to know either the candle-power of the source or the distance of the source from the point of observation, provided only that the solid angle subtended by the source and the emitting density (expressed preferably in lumens per unit area) are known. It is obvious therefore that, so far as calculations are concerned, any surface source of indefinite shape, size or location (such as the exposed sky surface) can be treated as equivalent to a definitely located source of definite shape and size provided only that such values are assigned to the dimensions and position of the substituted surface source that the solid angles are the same as before and the assumed emitting density of the substituted source is identical with that of the original. Hence in day-lighting problems it may be assumed that a plane surface source of sky-value emitting density having the exact dimensions of the exposed area of either a ceiling or a side-wall window can safely be substituted for the sky.

From all points within a room receiving an unobstructed view of the sky through a window, the window itself can be treated as the surface lighting source having an emitting density in lumens per unit area exactly equal to that of the sky. At point where the sky is partly hid from view through the window, the solid angle is correspondingly reduced for the full sky density, and a lower density must be assigned to the remaining portion of the original solid angle in accordance with the relative reflection coefficients of the obstructing areas on the side exposed to view through the window.

#### CIRCULAR SKY-WINDOW SOURCES

The above described method of substituting a surface source of known dimensions and location for some other source of more complex dimensions and uncertain location is invaluable in determining the illumination produced by the light received through ceiling

windows from either natural or artificial sources. For this purpose, it is most convenient to substitute for any square, rectangular or irregularly shaped window source a circular or elliptical source of equal emitting density, equivalent in area and in practical solid angular relations.

In Fig. 14, let  $ACB$  represent an edgewise view of a flat circular source, assumed to be in the ceiling of a room, having any chosen value of uniform emitting density and any desired radius. If through the edges  $A$  and  $B$  there be passed an imaginary sphere of any chosen size whatsoever—such as  $ADB$ —with its center at

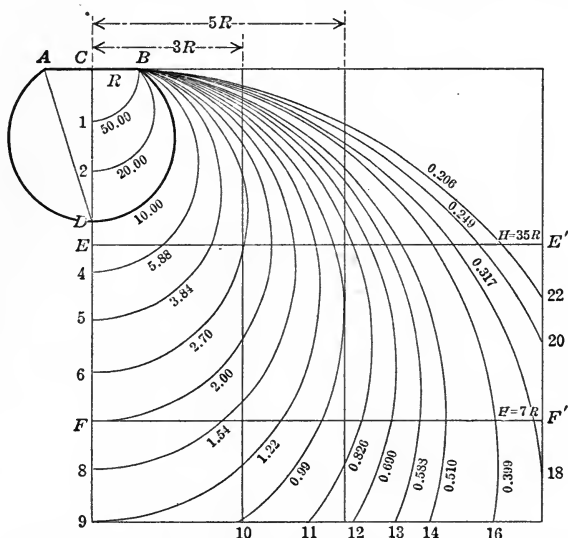

Fig. 14.—Equilux spheres with illuminating values in per cent. for spheres passing through points 1, 2, 3, 4, etc., length units below source.

some point on a vertical line passing through the center  $c$ , the inner surface of this imaginary sphere below the lighting source will receive an illumination which will be uniform in intensity normal to the surface of the sphere throughout the whole interior of the imaginary sphere.

The statement just made is not based on the equality of the solid angles subtended by the source when viewed from various points along the interior of the imaginary sphere; in fact, the solid angle is not constant but varies directly with the cosine of the plane angular deviation of the point of observation from the position directly below the center of the source. However, the above statement

applies not to the illumination density on a plane normal to the line of observation of the source from the point chosen but to the density normal to the imaginary sphere at this point. The ratio between these two densities varies inversely with the cosine of the angular deviation just mentioned, so that the final product is constant, and hence the density normal to the imaginary sphere is constant.

Evidently the exact value of the density (in lumens per unit area) of the normal illumination against the inner surface of the sphere will bear to the emitting density (in lumens per unit area) of the circular surface source the inverse ratio of the interior area of the exposed zone of the sphere to the area of the lighting source, since the lumens produced must equal those utilized. From solid geometrical relations it will be seen that this ratio equals the square of the radius  $AC$  to the diagonal  $AD$ . When the radius of the circular source is taken as the unit of length for the measurement of all distances, and the unit of illumination density (lumens per unit area) is taken as the emitting density of the source, then the percentage value of the illumination density on the interior of the sphere is equal to 100 divided by the square of the diagonal  $AD$ .

For convenience any sphere passing through the edges  $A$  and  $B$ , as just indicated, can be referred to as an "equilux" sphere (the "lux" being one of the several units of illumination). Equilux spheres of the proper sizes being employed, one is enabled "to explore the whole region" illuminated by the source, and to ascertain immediately for any desired point within the space explored the exact value of that component of the light flux which is normal to the particular equilux sphere passing through that point.

In Fig. 14 are indicated numerous equilux spheres and the points of intersection of these spheres with horizontal planes (floors) at light distances of 3.5 units and 7 units of length (radii) below the source, and with vertical planes (walls) 3 and 5 length units distant from the center of the source.

Points of intersection of the two assumed horizontal planes with the equilux spheres evidently lie on circles having as the common center the point on the floor immediately below the center of the circular ceiling lighting source.

It is an interesting fact that at any point on the floor the component of the flux normal to the floor is equal to the component normal to the equilux sphere at that point, so that the values of equilux density are simultaneously the values of light flux density normal

to the horizontal plane (floor). Expressed in other words, the illumination along the floor at any point is known at once when one has determined the value of light flux density on the equilux sphere passing through that point. Hence, the whole problem of floor illumination density and distribution determination is completely solved when the equilux spheres and intersecting lines have been constructed. One could not well wish for a simpler solution.

In Fig. 15 are shown results obtained directly from Fig. 14. It will be noted that with a ceiling height equal to 3.5 times the radius of the lighting source the light flux density at a point on the floor immediately below the center of the source reaches a value of about

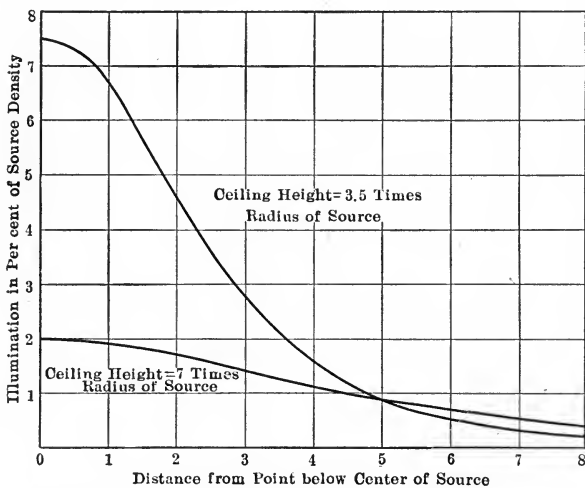

Fig. 15.—Graphs of illuminations on floors with two different ceiling heights.

7.55 per cent. of the emitting density of the source, while the density along the floor decreases rapidly with increase in the distance from the point of maximum density. With a ceiling twice as high as formerly the maximum light flux density is reduced to 2 per cent., but the rate of decrease with increase of distance from the point below the center of the source is much less; in fact, at distance greater than 5 units of length (radii) the light from the high source is greater than that from the low source. This fact will be appreciated when it is recalled that the "solid angle" subtended by the source when viewed from the floor at a great distance from the center is larger with the high ceiling than with the low ceiling.

Even in the case of ceiling sources it is at times desirable to calcu-

late the illumination on the side-walls, and it is well to have available some method for this purpose. When it is remembered that any method developed for use with ceiling window sources can be supplied at once to side window sources, it will be appreciated that the method of calculating the wall illumination with ceiling window sources becomes that of calculating the floor illumination with side window sources, and the desirability of having a simple method will be apparent. Such a method, for convenience described in connection with ceiling sources, is as follows:

At any point on any vertical plane as far below the ceiling source as this plane is distant from the center of the source in the normal (nearest) direction, the illumination normal to the vertical plane at that point is equal to that normal to the horizontal plane at this point. At any other point the normal illumination on the vertical plane bears to the normal illumination on the horizontal plane at this point, the ratio of the distance of the vertical to the distance of the horizontal plane from the center of the source, each distance being measured in a direction normal (shortest) to the plane considered. When solving problems relating to plane circular lighting sources by means of the equilux spheres one can easily determine the illumination normal to any horizontal plane and can then calculate the illumination on any vertical plane by *direct proportion*.

By obvious modifications the above described methods for determining the floor and wall illumination produced by circular ceiling sources, can be applied to similar problems relating to ceiling and side-wall sources of any shape or size, and to problems of all kinds relating to daylight illumination.

#### BRIGHTNESS UNIT—THE LAMBERT

Although it is not unusual to refer to an isolated lighting unit of the "point" type (that is, of the type treated as equivalent to a "point source" as distinguished from a "surface source"), as possessing a certain candle-power, yet it is recognized that the lighting characteristics of the source are not fully defined until the whole space distribution of the candle-power is so specified that the "mean spherical candle-power" or the output in lumens can be determined. Illumination calculations have been greatly simplified by the introduction of the "lumen" as a unit in which to express not only the output from the source but also the absorption by the surfaces illuminated, the total lumens produced by the source being in every case equal to the total lumens absorbed by the surfaces.

Moreover, certain seemingly complicated problems relating to surface sources, inter-reflecting walls, ceilings, etc., permit of the simplest possible solution when use is made of the lumen rather than the candle-power conception in expressing the output, the output density and the "appearance" of the source to the eye when viewed from various directions. The ratios involved in the substitution are fundamental and do not depend upon the character of the source, being the same for "non-mat" as for "mat" surfaces.

With a perfectly diffusing "mat" surface source, multiplying the constant value of "lumens per square foot" of the source by the total area of the source in square feet gives the exact value of the output in lumens independent in every respect of the shape or size of the source.

When use is made of the "apparent candle-power per square inch" in this connection multiplying this value by the whole area of the source in square inches does not give the "mean spherical candle-power of the source; it gives a value differing therefrom in the ratio of 1 to 4 under all conditions. In the single case of a perfectly diffusing spherical source—of which the projected area equals one-fourth the total area—the total mean spherical candle-power is equal to the product of the "apparent candle-power per square inch" by the *projected area* in square inches.

It is evident, therefore, that so far as concerns the output of "mat" surfaces, the expression *lumens per unit area* has a definite significance and cannot be misinterpreted, while the term "apparent candle-power per unit area" may or may not be correctly interpreted.

It is frequently assumed, tacitly, that a surface source is made up of an infinite number of "point sources." If such were the case, plain surface sources would emit in all directions rather than in one hemisphere, and the "cosine law" of emission would be invalid. The fact is that a surface source is made up of an infinite number of infinitesimal *plane surface* elements, each of which radiates in a single hemisphere and does not act like a point source. When the "cosine law" is applicable the "mean spherical candle-power" of each element of the source is equal to one-fourth of the maximum apparent candle-power of the element, or is equivalent to one-fourth of the total area of the element multiplied by the "apparent candle-power" per unit projected area viewed from any direction within the radiating hemisphere. Hence the universal 1 to 4 ratio noted above for "mat" surfaces.

In view of the fact that as a matter of actual practice almost all surface sources are either of the "mat" type or are treated as though they obeyed the "cosine law of emission," it would seem that the very great simplification in calculation brought about by substituting the lumen conception for the candle-power conception would fully justify the substitution even if the results obtained were somewhat inaccurate in the case of "non-mat" surfaces. The fact is, however, that the ratio involved in the substitution is absolutely fundamental and does not depend upon the character of the emitting surface.

As has already been shown the ratio of the "output in lumens per square foot" to the "apparent candle-power per square foot" of all "mat" surface sources is the constant  $\pi \div 1$ . It is equally true that the "apparent foot-candles" of a source of any character whatsoever viewed from any chosen direction bears to the "apparent candle-power per foot" of the same source viewed from the same direction the identical ratio  $\pi \div 1$  the " $\pi$  ratio" not being dependent in any respect upon the "cosine law of emission." The fact of the matter is that the  $\pi$  ratio is based on solid geometrical relations, and is independent of the space distribution of the candle-power in any direction except that toward the point under consideration.

That is to say, there is a definite numerical ratio between the apparent foot-candle density of a source and its apparent candle-power per square foot, which ratio is the same under all conceivable conditions of space distribution of the candle-power.

It can, therefore, be stated that any illumination photometer of the "pyrometer" type calibrated to read in "apparent emitted foot-candles" or "lamberts" will when pointed toward a bright surface give an exact measure of the "apparent candle-power per square inch" of the source provided only that the "apparent foot-candle" value is divided by  $144\pi$  or  $\pi$  as the case may be—a constant in no way dependent upon the "cosine law."

Hence in order to determine the "apparent candle-power per square inch" of a surface source in a chosen direction, it is unnecessary to measure the apparent candle-power in this direction of a limited isolated section of known projected area; the identical result can be obtained much more conveniently by observing the "apparent foot-candle density" (apparent lumens per square foot) or "lamberts (lumens per sq. cm.)" of the source when viewed from the chosen direction and dividing this value by the constant  $144\pi$  or  $\pi$ .



It is to be noted that, independent in every respect of the name given to the quantity dealt with, the measurable value of the "apparent foot-candle" density of a surface source differs from the measurable "apparent candle-power per square inch" of the same source viewed in the same direction in a definite numerical ratio, without regard to the character of the surface. The "apparent candle-power per square inch" is known as "brightness" and the "apparent foot-candle density" observed from the same direction is also "brightness."

The unit of "brightness," the "lambert" is equal to neither the "apparent foot-candle" nor the "apparent candle-power per square inch." It is identical with the "apparent lumen per square centimeter," being 929 times as bright as the "apparent lumen per square foot" or its equivalent the "apparent foot-candle." Hence a perfectly diffusing surface emitting or reflecting one lumen per square foot (one apparent foot-candle) will have a brightness of 1.076 millilamberts.

The mean effective value of the *output density* of a surface source (and all practical sources are surfaces) can best be found by dividing the total output in lumens by the total area of the source expressed in some convenient unit. This numerical value is absolutely identical with the mean effective value of the *appearance* of the source in apparent lumens per square foot ("apparent foot-candles") or apparent lumens per sq. cm. ("lamberts"), the latter being the standardized unit for expressing the "appearance" or "brightness" of a surface source.

Only in the case of a perfectly "mat" source is either the "output density" or the "appearance" uniform in all directions, but no error is involved in the solution of problems dealing with non-uniform sources when mean effective values are substituted for the variable space values, provided only that the solution is recognized as being expressed in mean effective values.

For example, one can determine quickly by the use of mean effective values the *average* illumination produced over, say, the whole floor area of a room, but when he wishes to know the space variations in the illumination throughout a room he must resort to some more laborious point-by-point method. In most problems of today, with lighting units giving widely distributed flux the prime essential feature is no longer the proper space distribution of the illumination, but rather the production of adequate average illumination without excessive brightness in the field of view.

## PRESENT DAY CALCULATING METHODS

The adoption of the method of expressing the "brightness" or "appearance" of a lighting source in terms of physical reality based on the "surface-source" conception, rather than using the mathematically derived expression of brightness in terms of tacitly assumed point-sources with surface-source characteristics, represents a step in the progress of illumination calculations from the methods of the mathematical-physicist to those of the engineer similar in results accomplished to the adoption of the now universally employed magnetic flux and flux-density conceptions for the earlier isolated magnetic pole conception in the evolution of electrical calculations from those of the physicist to those of the engineer.

Similarly the practical abandonment of the laborious point-by-point methods of illumination determination in favor of the much more rapid output-utilization methods based on the law of conservation, converts the calculations of the lighting expert from those of the physicist to those of the engineer. Just as the mathematical physicist will continue to deal with fictitious isolated magnetic poles and by careful transformation of his equations will derive results in exact accord with physical facts, so will he continue to employ point-source conception and the point-by-point methods of calculations and his results will be true to nature, but the practical illuminating engineer will train his mind to think in terms of surface sources rather than point-sources, and will base the few equations needed by him in his everyday work on the law of conservation—either directly or indirectly recognized. The results obtained by him with the minimum of exertion will be absolutely identical with the results derived much more laboriously by the physicist employing the time-honored methods with which he is familiar.

## ILLUMINATION UNITS AND NOMENCLATURE

In order to render most serviceable for reference the book in which these lectures are reprinted there is here presented the latest (1916) list of units, definitions and abbreviations of the Committee on Nomenclature and Standards of the Illuminating Engineering Society.

## DEFINITIONS

**1. Luminous Flux** is radiant power evaluated according to its visibility; *i.e.*, its capacity to produce the sensation of light.

2. The visibility,  $K_\lambda$  of radiation, of a particular wave-length, is the ratio of the luminous flux to the radiant power producing it.

3. The mean value of the visibility,  $K_m$ , over any range of wave-lengths, or for the whole visible spectrum of any source, is the ratio of the total luminous flux (in lumens) to the total radiant power (in ergs per second, but more commonly in watts).

4. The luminous intensity,  $I$ , of a point source of light is the solid angular density of the luminous flux emitted by the source in the direction considered; or it is the flux per unit solid angle from that source.

Defining equation:

$$I = \frac{dF}{d\omega}$$

or, if the intensity is uniform,

$$I = \frac{F}{\omega},$$

where  $\omega$  is the solid angle.

5. Strictly speaking no point source exists, but any source of dimensions which are negligibly small by comparison with the distance at which it is observed may be treated as a point source.

6. Illumination, on a surface, is the luminous flux-density on that surface, or the flux per unit of intercepting area.

Defining equation:

$$E = \frac{dF}{dS},$$

or, when uniform,

$$E = \frac{F}{S},$$

where  $S$  is the area of the intercepting surface.

7. Candle—the unit of luminous intensity maintained by the national laboratories of France, Great Britain, and the United States.<sup>1</sup>

8. Candlepower—luminous intensity expressed in candles.

9. Lumen—the unit of luminous flux, equal to the flux emitted in a unit solid angle (steradian) by a point source of one candle-power.<sup>2</sup>

10. Lux—a unit of illumination equal to one lumen per square meter. The cgs. unit of illumination is one lumen per square centimeter. For this unit Blondel has proposed the name "Phot." One millilumen per square centimeter (milliphot) is a practical derivative of the cgs. system. One foot-candle is one lumen per square foot and is equal to 1.0764 milliphots.

The milliphot is recommended for scientific records.

11. Exposure—the product of an illumination by the time. Blondel has proposed the name "phot-second" for the unit of exposure in the cgs. system. The microphot second (0.00001 phot-second) is a convenient unit for photographic plate exposure.

<sup>1</sup> This unit, which is used also by many other countries, is frequently referred to as the international candle.

<sup>2</sup> A uniform source of one candle emits  $4\pi$  lumens.

**12. Specific luminous radiation,  $E'$** —the luminous flux-density emitted by a surface, or the flux emitted per unit of emissive area. It is expressed in lumens per square centimeter.

Defining equation:

For surfaces obeying Lambert's cosine law of emission,

$$E' = \pi b_0.$$

**13. Brightness,  $b$** , of an element of a luminous surface from a given position, may be expressed in terms of the luminous intensity per unit area of the surface projected on a plane perpendicular to the line of sight, and including only a surface of dimensions negligibly small in comparison with the distance at which it is observed. It is measured in candles per square centimeter of the projected area.

Defining equation:

$$b = \frac{dI}{dS \cos \theta},$$

(where  $\theta$  is the angle between the normal to the surface and the line of sight).

**14. Normal brightness,  $b_0$** , of an element of a surface (sometimes called specific luminous intensity) is the brightness taken in a direction normal to the surface.<sup>1</sup>

Defining equation:

$$b_0 = \frac{dI}{dS},$$

or, when uniform,

$$b_0 = \frac{I}{S}.$$

**15. Brightness** may also be expressed in terms of the specific luminous radiation of an ideal surface of perfect diffusing qualities, *i.e.*, one obeying Lambert's cosine law.

**16. Lambert**—the cgs. unit of brightness, the brightness of a perfectly diffusing surface radiating or reflecting one lumen per square centimeter. This is equivalent to the brightness of a perfectly diffusing surface having a coefficient of reflection equal to unity and an illumination of one phot. For most purposes, the millilambert (0.001 lambert) is the preferable practical unit.

A perfectly diffusing surface emitting one lumen per square foot will have a brightness of 1.076 millilamberts.

Brightness expressed in candles per square centimeter may be reduced to lamberts by multiplying by  $\pi = 3.14$ .

Brightness expressed in candles per square inch may be reduced to foot-candle brightness by multiplying by the factor  $144\pi = 452$ .

<sup>1</sup> In practice, the brightness  $b$  of a luminous surface or element thereof is observed and not the normal brightness  $b_0$ . For surfaces for which the cosine law of emission holds, the quantities  $b$  and  $b_0$  are equal.

Brightness expressed in candles per square inch may be reduced to lamberts by multiplying by  $\pi/6.45 = 0.4868$ .

In practice, no surface obeys exactly Lambert's cosine law of emission; hence the brightness of a surface in lamberts is, in general, not numerically equal to its specific luminous radiation in lumens per square centimeter.

Defining equations:

$$L = \frac{dF}{dS}$$

or, when uniform,

$$L = \frac{F}{S}$$

**17. Coefficient of reflection**—the ratio of the total luminous flux reflected by a surface to the total luminous flux incident upon it. It is a simple numeric. The reflection from a surface may be regular, diffuse or mixed. In perfect regular reflection, all of the flux is reflected from the surface at an angle of reflection equal to the angle of incidence. In perfect diffuse reflection the flux is reflected from the surface in all directions in accordance with Lambert's cosine law. In most practical cases there is a superposition of regular and diffuse reflection.

**18. Coefficient of regular reflection** is the ratio of the luminous flux reflected regularly to the total incident flux.

**19. Coefficient of diffuse reflection** is the ratio of the luminous flux reflected diffusely to the total incident flux.

Defining equation:

Let  $m$  be the coefficient of reflection (regular or diffuse).

Then, for any given portion of the surface,

$$m = \frac{E'}{E}$$

**20. Lamp**—a generic term for an artificial source of light.

**21. Primary luminous standard**—a recognized standard luminous source reproducible from specifications.

**22. Representative luminous standard**—a standard of luminous intensity adopted as the authoritative custodian of the accepted value of the unit.

**23. Reference standard**—a standard calibrated in terms of the unit from either a primary or representative standard and used for the calibration of working standards.

**24. Working standard**—any standardized luminous source for daily use in photometry.

**25. Comparison lamp**—a lamp of constant but not necessarily known candlepower against which a working standard and test lamp are successively compared in a photometer.

**26. Test lamp**, in a photometer—a lamp to be tested.

**27. Performance curve**—a curve representing the behavior of a lamp in any particular (candlepower, consumption, etc.) at different periods during its life.

**28. Characteristic curve**—a curve expressing a relation between two variable properties of a luminous source, as candlepower and volts, candlepower and rate of fuel consumption, etc.

**29. Horizontal distribution curve**—a polar curve representing the luminous intensity of a lamp, or lighting unit, in a plane perpendicular to the axis of the unit, and with the unit at the origin.

**30. Vertical distribution curve**—a polar curve representing the luminous intensity of a lamp, or lighting unit, in a plane passing through the axis of the unit and with the unit at the origin. Unless otherwise specified, a vertical distribution curve is assumed to be an average vertical distribution curve, such as may in many cases be obtained by rotating the unit about its axis, and measuring the average intensities at the different elevations. It is recommended that in vertical distribution curves, angles of elevation shall be counted positively from the nadir as zero, to the zenith as  $180^\circ$ . In the case of incandescent lamps, it is assumed that the vertical distribution curve is taken with the tip downward.

**31. Mean horizontal candlepower** of a lamp—the average candlepower in the horizontal plane passing through the luminous center of the lamp.

It is here assumed that the lamp (or other light source) is mounted in the usual manner, or, as in the case of an incandescent lamp, with its axis of symmetry vertical.

**32. Mean spherical candlepower** of a lamp—the average candlepower of a lamp in all directions in space. It is equal to the total luminous flux of the lamp in lumens divided by  $4\pi$ .

**33. Mean hemispherical candlepower** of a lamp (upper or lower)—the average candlepower of a lamp in the hemisphere considered. It is equal to the total luminous flux emitted by the lamp in that hemisphere divided by  $2\pi$ .

**34. Mean zonal candlepower** of a lamp—the average candlepower of a lamp over the given zone. It is equal to the total luminous flux emitted by the lamp in that zone divided by the solid angle of the zone.

**35. Spherical reduction factor** of a lamp—the ratio of the mean spherical to the mean horizontal candlepower of the lamp.<sup>1</sup>

**36. Photometric tests** in which the results are stated in candlepower should be made at such a distance from the source of light that the latter may be regarded as practically a point. Where tests are made in the measurement of lamps with reflectors, or other accessories at distances such that the inverse-square law does not apply, the results should always be given as "apparent candlepower" at the distance employed, which distance should always be specifically stated.

<sup>1</sup> In the case of a uniform point-source, this factor would be unity, and for a straight cylindrical filament obeying the cosine law it would be  $\pi/4$ .

The output of all illuminants should be expressed in lumens.

**37. Illuminants should be rated** upon a lumen basis instead of a candle-power basis.

**38. The specific output of electric lamps** should be stated in terms of lumens per watt and the specific output of illuminants depending upon combustion should be stated in lumens per British thermal unit per hour. The use of the term "efficiency" in this connection should be discouraged.

When auxiliary devices are necessarily employed in circuit with a lamp, the input should be taken to include both that in the lamp and that in the auxiliary devices. For example, the watts lost in the ballast resistance of an arc lamp are properly chargeable to the lamp.

**39. The specific consumption** of an electric lamp is its watt consumption per lumen. "Watts per candle" is a term used commercially in connection with electric incandescent lamps, and denotes watts per mean horizontal candle.

**40. Life tests**—Electric incandescent lamps of a given type may be assumed to operate under comparable conditions only when their lumens per watt consumed are the same. Life test results, in order to be compared must be either conducted under, or reduced to, comparable conditions of operation.

**41. In comparing different luminous sources**, not only should their candlepower be compared, but also their relative form, brightness, distribution of illumination and character of light.

**42. Lamp Accessories.**—A **reflector** is an appliance the chief use of which is to redirect the luminous flux of a lamp in a desired direction or directions.

**43. A shade** is an appliance the chief use of which is to diminish or to interrupt the flux of a lamp in certain directions where such flux is not desirable. The function of a shade is commonly combined with that of a reflector.

**44. A globe** is an enclosing appliance of clear or diffusing material the chief use of which is either to protect the lamp or to diffuse its light.

#### 45. Photometric Units and Abbreviations.

Photometric quantity	Name of unit	Symbols and defining equations	Abbreviation for name of unit
1. Luminous flux	Lumen	$F, \Psi$	lm
2. Luminous intensity	Candle	$I = \frac{dF}{d\omega}, \Gamma = \frac{d\Psi}{d\omega}$	cp.
3. Illumination	Phot, foot-candle, lux	$E = \frac{dF}{dS} = \frac{I}{r^2} \cos \theta, \beta$	ph. fc.
4. Exposure	{ Phot-second Micro phot-second	$Et$	phs. $\mu$ phs.

Photometric quantity	Name of unit	Symbols and defining equations	Abbreviation for name of unit
5. Brightness	Apparent candle per sq.cm.	$b = \frac{dI}{dS \cos \theta}$	—
	Apparent candle per sq. in.	$L = \frac{dF}{dS}$	—
	Lambert		—
6. Normal brightness	Candles per sq.cm.	$b_0 = \frac{dI}{dS}$	—
	Candles per sq. in.		—
7. Specific luminous radiation	Lumens per sq.cm.	$E' = \pi b_0, \beta'$	—
	Lumens per sq. in.		
8. Coefficient of reflection	—	$m = \frac{E'}{E}$	—
9. Mean spherical candlepower		scp.	
10. Mean lower hemispherical candlepower		lcp.	
11. Mean upper hemispherical candlepower		ucp.	
12. Mean zonal candlepower		zcp.	
13. Mean horizontal candlepower		mhch.	
14.	1 lumen is emitted by 0.07958 spherical candlepower.		
15.	1 spherical candlepower emits 12.57 lumens.		
16.	1 lux = 1 lumen incident per square meter = 0.0001 phot = 0.1 milliphot.		
17.	1 phot = 1 lumen incident per square centimeter = 10,000 lux = 1,000 milliphots = 1,000,000 microphots.		
18.	1 milliphot = 0.001 phot = 0.929 foot-candle.		
19.	1 foot-candle = 1 lumen incident per square foot = 1.076 milliphots = 10.76 lux.		
20.	1 lambert = 1 lumen emitted per square centimeter of a perfectly diffusing surface.		
21.	1 millilambert = 0.001 lambert.		
22.	1 lumen, emitted, per square foot <sup>1</sup> = 1.076 millilamberts.		
23.	1 millilambert = 0.929 lumen, emitted, per square foot. <sup>1</sup>		
24.	1 lambert = 0.3183 candle per square centimeter = 2.054 candles per square inch.		
25.	1 candle per square centimeter = 3.1416 lamberts.		
26.	1 candle per square inch = 0.4868 lambert = 486.8 millilamberts.		

**46. Symbols.**—In view of the fact that the symbols heretofore proposed by this committee conflict in some cases with symbols adopted for electric units by the International Electrotechnical Commission, it is proposed that where the possibility of any confusion exists in the use of electrical and photometrical symbols, an alternative system of symbols for photometrical quantities should be employed. These should be derived exclusively from the Greek alphabet, for instance:

Luminous intensity.....	$\Gamma$
Luminous flux.....	$\Psi$
Illumination.....	$\beta$

<sup>1</sup> Perfect diffusion assumed.





# PRINCIPLES OF INTERIOR ILLUMINATION

BY A COMMITTEE

J. R. CRAVATH, CHAIRMAN

WARD HARRISON

ROBERT ff. PIERCE

## PART I. ELEMENTS OF DESIGN

As the subject of illumination units and calculations is treated in a separate lecture only those parts of this subject of immediate practical application to design will be taken up here, and no attempt will be made to explain the derivation of units, or the terms or diagrams here mentioned in connection with calculations.

### CALCULATIONS

*Measurement and Expression of Light Output from Sources.*—One of the first things necessary in illumination calculations for interiors is a knowledge of the light output or luminous performance of various sources of light available for lighting the interior in question. In connection with the light output of a source it is important that we should know: (a) how the light is distributed from the source, that is, the candle-power distribution or intensity in various directions; (b) the flux of light in lumens or mean spherical candle-power; and (c) the brightness per unit area of the source of light.

*Candle-power Distribution.*—The polar coördinate curve, Fig. 1, is the common means of expressing the intensity of candle-power of light in various directions from a source. Such a curve (in which the candle-power is shown by the distance of the curve from the reference point or light source) gives at a glance a good idea of the characteristics of light distribution from the source, provided the distribution of light is symmetrical around a vertical axis. If it is not symmetrical, of course, several curves plotted from candle-power readings in different planes are necessary.

The practising engineer should be an industrious student and collector of curves of this kind.

*Light Flux.*—The total output or flux of light in lumens (which is 12.57 times the mean spherical candle-power) is sometimes graphically expressed by a Rousseau diagram but more frequently by numerals showing the lumens emitted in different zones together with the total lumens.

The mathematical derivation of light flux from the polar coördinate curve is out of the scope of this lecture except that one short-cut method of great practical convenience for quickly determining the light flux in any zone or zones from a common polar co-

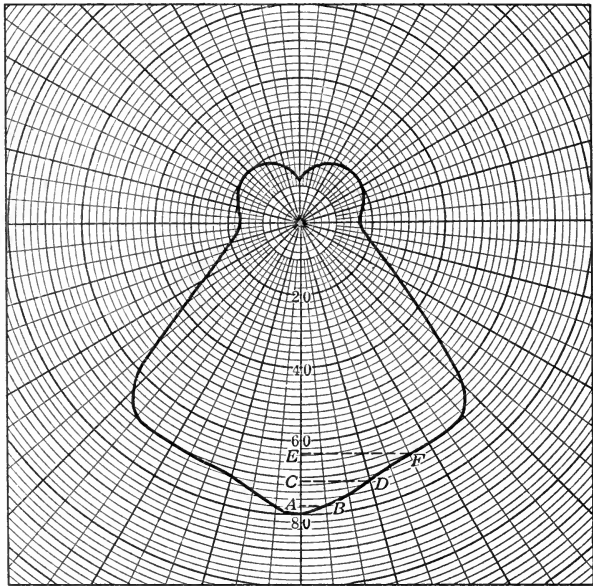

Fig. 1.—Polar coördinate candle-power curve.

ördinate curve should be mentioned. The method is based on the principle that on a polar coördinate curve the light flux in various zones is proportional to the length of a perpendicular line drawn from the candle-power curve at the middle of the zone to the vertical axis. If we take the sum of the perpendicular distances for 10-deg. zones (such as *AB* plus *CD* plus *EF* etc., in Fig. 1) from the curve to the vertical as measured from the center of each 10-deg. zone (measuring these distances by the same scale as the candle-power scale of the curve) and add 10 per cent. to this sum, the result will be the total lumens in the zones under considera-

tion. The quick way to get this sum is by the use of a strip of paper and a sharp pencil. Starting at a marked zero point measure the perpendicular distance from the curve to the vertical 10-deg. zone at the 5-deg. point (*AB* Fig. 1) marking it on the strip. Then with the last mark as a starting place measure the distance for the second zone, *CD* from the vertical to the curve at the 15-deg. point, and so on adding each perpendicular distance for every 10 degrees to the one before, over the whole 180 degrees. Then by using the candle-power scale of the curve to measure the total length of the slip of paper so measured off and adding 10 per cent., the numerical value of the lumens emitted in any zone or for the entire sphere 0 to 180 degrees is quickly ascertained. Obviously the same method applies to any one or more of the 10-deg. zones into which the sphere is divided by this method, so that the lumens can be thus determined for any one or more 10-deg. zones.

The brightness over the area of the source of light (or of the source of light with its enclosing equipment such as a globe or reflector) is of much importance in connection with the hygiene of the eye in designing interior illumination. Such brightness has been expressed in many units, such as candles per square centimeter, candles per square inch, candles per square foot, etc., but practice is rapidly settling to the new unit approved by our Society, namely, the "lambert" and its 1000th part, the millilambert. The latter is about equal to the brightness of white blotting paper when illuminated with 1.25 foot-candles. Table I shows the relation of various brightness units.

TABLE I.—CONVERSION TABLE FOR VARIOUS BRIGHTNESS VALUES

Values in units in this column × conversion factor = value in units at top of column	Candles per sq. cm.	Candles per sq. inch	Candles per sq. meter	Candles per sq. foot	Lamberts (ap- parent lum. per sq. cm.)	Ft.-candles (ap- parent lumens per sq. foot)	Millilamberts
Candles per sq. cm.....	1	6.451	10,000	929.03	3.14	2918	3141.6
Candles per sq. inch.....	.155	1	1550	144	.4867*	452	486.7
Candles per sq. meter.....	.0001	.00064	1	.0929	.000314	.2918	.31416
		51					
Candles per sq. foot.....	.00108	.0069	10.70	1	.00339— 12	3.14	3.3912
Lamberts (apparent lumens per sq. cm.).....	.318	2.054	3180	295.8	1	929.03	1000
Foot-candles (apparent lumens per sq. foot).....	.000343	.00214	3.40	.318	.00108	1	1.076
Millilamberts.....	.000318	.002054	3.180	.2958	.001	.929	1

*Luminous Output of Bare Light Sources.*—Although in good practice in the lighting of interiors, the lamps are seldom used bare without reflectors, shades or globes of any kind, it is nevertheless of fundamental importance to the engineer to know the luminous output of the various sources of light without auxiliary equipment. Then he can proceed with his calculations by allowing the proper percentage of loss for whatever equipment is used around the lamps.

The luminous output of different kinds of lamps per unit of input has been rapidly changing during the past few years owing to improvements in the art and will probably continue to change so that any data given here must be taken with the idea that they must be revised from various reliable sources at frequent intervals.

Table II shows the lumens and the lumens per watt for a number  
TABLE II.—LUMENS OUTPUT OF AMERICAN TUNGSTEN INCANDESCENT LAMPS  
JULY 1, 1916

Watts	Watts per spherical c.p.	Lumens per watt	Total lumens
105-125 VOLT MAZDA B LAMPS			
10	1.67	7.50	75
15	1.47	8.55	128
20	1.41	8.90	178
25	1.35	9.30	234
40	1.32	9.50	380
50	1.31	9.60	480
60	1.28	9.80	590
100	1.22	10.3	1,030
105-125 VOLT MAZDA C LAMPS			
75	1.09	11.5	865
100	1.00	12.6	1,260
200	0.90	14.0	2,800
300	0.82	15.3	4,600
400	0.82	15.3	6,150
500	0.78	16.1	8,050
750	0.74	17.0	12,800
1,000	0.70	18.0	18,000

NOTE.—220 Volt lamps are about 10 per cent. less efficient.

of the commonest sizes and types of tungsten filament incandescent lamps, new, as made and used in the United States, August, 1916, when operated at a voltage giving an average rated life of 1000 hours. From this it is seen that the lumens per watt range from 7.5 for the 10-watt size to 18 for the 1000-watt size.

Gas mantle burners, new, and properly adjusted range in specific output from 200 to 325 lumens per cubic foot of gas per hour in sizes giving 400 to 3000 lumens. These figures vary with the composition of the gas and many other factors.

The amount of light obtained from the old-fashioned open flame burner gas jet depends upon the richness of the gas in certain hydrocarbons which produce a yellow flame in the open jet. This quality is commonly known as the candle-power of the gas and was at one time the common standard by which gas was rated. With the gas mantle, however, the candle-power according to the old standards has nothing to do with the light output of the burner which in this case depends on the composition of the gas.

The efficiencies of lamps burning acetylene, Blau gas, alcohol, kerosene and gasoline vary considerably, depending upon the design of the burner, the purity of the illuminant and the conditions of supply. The following figures have been actually obtained under favorable conditions, but do not necessarily represent the maximum obtainable. On the other hand, the average results in the case of kerosene and gasoline are probably much below the stated values.

	Lumen, hours, per cu. ft.
Acetylene (open flame).....	500
Acetylene (mantle).....	900
Blau gas (mantle).....	400
	Per gallon
Kerosene (round wick open flame).....	9,000
Kerosene (mantle).....	24,000
Kerosene (mantle-pressure type).....	80,000
Gasoline (mantle-low pressure).....	80,000
Alcohol (mantle).....	16,000

Kerosene lamps in particular suffer a considerable decrease in efficiency during burning.

The older carbon filament incandescent lamp gave a specific output of from 2.5 to 4 lumens per watt.

Prismatic reflectors offer a control of light which approaches that of the mirror. Considerable light passes through the reflector at the tops and bottoms of the prisms.

For indirect lighting and semi-indirect with dense reflectors it can be shown theoretically that the best reflector for the purpose would distribute light evenly over the whole ceiling area served from one fixture.

That is, in a small room, with one central fixture, the whole ceiling would be evenly illuminated; or in a large room with a fixture in the center of each bay each reflector would evenly illuminate that bay. By confining a considerable portion of the light flux to the center of the ceiling with a fixture hung in the middle of the room, more of the light flux will reach the working plane after one reflection from the ceiling than if the distribution over the ceiling were more uniform. The more even the distribution the greater the amount of light lost by absorption at the walls. However, from the standpoint of the desk worker there is some advantage in having the ceiling evenly illuminated as there is some tendency to specular reflection from the brightest portions of the ceiling causing a slight veiling glare. This glare is not so pronounced if the ceiling is evenly illuminated. An indirect reflector giving uniform ceiling distribution must be of the deep bowl type, but this type has a very sharp "cut-off" or transition from high to low illumination at the edge of the reflector. This causes a shadow on the ceiling which is objectionable and calls for some modification of uniform ceiling distribution. Two principal ways of overcoming this have been worked out in practice which work well with non-concentrated light sources. One is to use a shape similar to the deep bowl distributing type for the lower part of the reflector and a flaring bell-shaped one for the upper part. The other plan is to use a large reflector of the shallow bowl-shape. The former plan is used mainly with mirrored reflectors where it is desirable on account of first cost, to keep down the size while the other plan is used with white enamel reflectors and for semi-direct lighting with large glass bowls. While it may be immaterial for the engineer who plans the lighting installation how the result of eliminating dark shadows from the ceiling is accomplished it must nevertheless always be kept in mind that good design calls for the elimination of these shadows to a large extent by tapering off the brightness from the center to the edges of the illuminated area covered by each reflector.

For semi-indirect lighting a plain bowl somewhat shallower than

a hemisphere is likely to give the best results in efficiency. Ornamental designs in which the maximum diameter of the bowl is greater than the diameter at the top cause considerable loss of light because of the light which is intercepted by the part of the bowl projecting inward. Therefore when such designs are used this extra loss should be recognized in the calculations and a decision reached whether the ornamental effect attained is sufficient to justify the loss.

While the placing of lamps and shaping of semi-indirect bowls is not as important as in the case of indirect reflectors of the opaque type, it is not by any means a matter of indifference. The lamps should be placed in a position not to cause undue shadows on ceilings or walls or too uneven illumination on the bowls as viewed from below.

Angle reflectors may be obtained giving a number of different types of distribution for special purposes such as show window lighting, bulletin board lighting and other cases where more light is wanted on one side of the plane through the lamp axis than on the other. They cannot be classified into general types as there is such a variety. Makers data should be thoroughly studied as to the forms available.

Shifting the position of a lamp in a reflector by the use of different forms of shade holders may materially change the light distribution.

In the selection of reflectors for any purpose it is always well to remember the fundamental principle that control of the light flux is the end to be desired if the flux is not to be wasted by escaping to places where it is not needed or positively undesirable. The larger the percentage of the total flux of light from the lamp which the reflector intercepts and reflects in desired directions the higher the efficiency; unless, however, the natural undirected flux from the lamp approximates the distribution desired. With reflectors which must confine the light flux of the lamp within rather restricted areas as in show windows and for localized lighting of work benches and the like it is important to use reflectors large enough to intercept a considerable portion of the light flux. There is apt to be a tendency to cut down reflector sizes to save first cost but such reduction usually means a permanent impairment of efficiency. This is also true in the lighting of a large high room of the armory or coliseum type where the lamps must be placed high and all light emanating from reflectors at angles only a little below the horizontal is likely to undergo serious loss by striking dark roof and walls.

*Sky Brightness Characteristics* useful for design of natural illumina-



Prismatic reflectors offer a control of light which approaches that of the mirror. Considerable light passes through the reflector at the tops and bottoms of the prisms.

For indirect lighting and semi-indirect with dense reflectors it can be shown theoretically that the best reflector for the purpose would distribute light evenly over the whole ceiling area served from one fixture.

That is, in a small room, with one central fixture, the whole ceiling would be evenly illuminated; or in a large room with a fixture in the center of each bay each reflector would evenly illuminate that bay. By confining a considerable portion of the light flux to the center of the ceiling with a fixture hung in the middle of the room, more of the light flux will reach the working plane after one reflection from the ceiling than if the distribution over the ceiling were more uniform. The more even the distribution the greater the amount of light lost by absorption at the walls. However, from the standpoint of the desk worker there is some advantage in having the ceiling evenly illuminated as there is some tendency to specular reflection from the brightest portions of the ceiling causing a slight veiling glare. This glare is not so pronounced if the ceiling is evenly illuminated. An indirect reflector giving uniform ceiling distribution must be of the deep bowl type, but this type has a very sharp "cut-off" or transition from high to low illumination at the edge of the reflector. This causes a shadow on the ceiling which is objectionable and calls for some modification of uniform ceiling distribution. Two principal ways of overcoming this have been worked out in practice which work well with non-concentrated light sources. One is to use a shape similar to the deep bowl distributing type for the lower part of the reflector and a flaring bell-shaped one for the upper part. The other plan is to use a large reflector of the shallow bowl-shape. The former plan is used mainly with mirrored reflectors where it is desirable on account of first cost, to keep down the size while the other plan is used with white enamel reflectors and for semi-direct lighting with large glass bowls. While it may be immaterial for the engineer who plans the lighting installation how the result of eliminating dark shadows from the ceiling is accomplished it must nevertheless always be kept in mind that good design calls for the elimination of these shadows to a large extent by tapering off the brightness from the center to the edges of the illuminated area covered by each reflector.

For semi-indirect lighting a plain bowl somewhat shallower than

a hemisphere is likely to give the best results in efficiency. Ornamental designs in which the maximum diameter of the bowl is greater than the diameter at the top cause considerable loss of light because of the light which is intercepted by the part of the bowl projecting inward. Therefore when such designs are used this extra loss should be recognized in the calculations and a decision reached whether the ornamental effect attained is sufficient to justify the loss.

While the placing of lamps and shaping of semi-indirect bowls is not as important as in the case of indirect reflectors of the opaque type, it is not by any means a matter of indifference. The lamps should be placed in a position not to cause undue shadows on ceilings or walls or too uneven illumination on the bowls as viewed from below.

Angle reflectors may be obtained giving a number of different types of distribution for special purposes such as show window lighting, bulletin board lighting and other cases where more light is wanted on one side of the plane through the lamp axis than on the other. They cannot be classified into general types as there is such a variety. Makers data should be thoroughly studied as to the forms available.

Shifting the position of a lamp in a reflector by the use of different forms of shade holders may materially change the light distribution.

In the selection of reflectors for any purpose it is always well to remember the fundamental principle that control of the light flux is the end to be desired if the flux is not to be wasted by escaping to places where it is not needed or positively undesirable. The larger the percentage of the total flux of light from the lamp which the reflector intercepts and reflects in desired directions the higher the efficiency; unless, however, the natural undirected flux from the lamp approximates the distribution desired. With reflectors which must confine the light flux of the lamp within rather restricted areas as in show windows and for localized lighting of work benches and the like it is important to use reflectors large enough to intercept a considerable portion of the light flux. There is apt to be a tendency to cut down reflector sizes to save first cost but such reduction usually means a permanent impairment of efficiency! This is also true in the lighting of a large high room of the armory or coliseum type where the lamps must be placed high and all light emanating from reflectors at angles only a little below the horizontal is likely to undergo serious loss by striking dark roof and walls.

*Sky Brightness Characteristics* useful for design of natural illumina-

tion are given in Table III. It will be seen that there is an enormous variation in the brightness of the sky during what are ordinarily

TABLE III.—SKY BRIGHTNESS

	Brightness in millilamberts
Sky, with light clouds.....	2,000
Sky, clouds predominating, generally cumulus..	1,900
Sky, blue predominating, clouds cirrus.....	1,500
Sky, cloudless, either clear blue or hazy.....	1,000
Sky, cloudy, storm near or present.....	700 to 70
Walls, typical rooms, ordinary range diffused daylight through window.....	50 to 1

considered daylight hours. Calculations of daylight illumination of interiors should therefore be made on the basis of maximum and minimum values.

The sky is the principal source of daylight illumination of interiors, as the illumination obtained directly from the sun may be considered as purely incidental and frequently avoided by the use of shades.

In connection with daylight we have first to consider the amount of sky exposure through side or ceiling windows; the amount of illumination (excluding reflection from walls and other buildings on any point) varying directly according to the area of the exposure as projected from the point in question. Part of the window area may be obstructed by buildings and in certain cases the reflection of light from these buildings (or in other words their brightness) must also be taken into account as well as that of the sky.

*Illumination from Direct Sunlight* in the open has been found to reach approximately 9000 foot-candles, in Virginia, during the summer months as measured on a horizontal plane. Extensive measurements made there by Prof. Herbert H. Kimball, of the U. S. Weather Bureau, show that the total illumination from sun and sky during the middle of the day consists of about 20 per cent. skylight and 80 per cent. direct sunlight. Sunlight shining into interiors therefore may have about 80 per cent. of its outdoor value.

With clear glass windows the only sky brightness which is useful for illumination of the room is that directly visible from the interior of the room. If the window is obstructed by buildings the sky brightness is not available. Where a window is exposed to sky

area either above or at one side, and the illumination from such area does not reach back into the room far enough, prisms and diffusing glasses of various kinds are applicable. The action of the prism glass window is to bend the light rays so that they strike back further into the room than if a clear glass window were used. Rough and ribbed glasses accomplish the same end with less precision and effectiveness. They diffuse the light rays passing through, and a certain portion of such rays are directed back into the room. For some locations louvers or shutters consisting of partially or wholly opaque strips which can be tilted at any angle make it possible to regulate the relative amount of sun and skylight or cut out direct sunlight without too serious a reduction in the skylight. The common method of controlling sunlight is by translucent shades but this method for some interiors (such as art galleries) does not offer very accurate control.

*The Brightness or Intrinsic Brilliancy of Various Artificial Light Sources* and also the brightness of some sources equipped with diffusing glassware for the protection of the eyes is shown in Table IV.

TABLE IV.—BRIGHTNESS OF ARTIFICIAL LIGHT SOURCES

	Brightness in millilamberts
Crater, carbon arc.....	40,800,000
Flaming arc, clear globe.....	2,435,000
Magnetite arc, clear globe.....	1,945,000
Gas-filled tungsten electric light filament.....	1,400,000
Incandescent electric tungsten, 1.25 watts per candle.....	516,000
Quartz tube, mercury vapor arc.....	486,700-292,000
Incandescent electric carbon filament, 3.1 watts per candle.....	236,000
Acetylene flame (1 foot burner).....	25,800
Welsbach mantle.....	15,080
Cooper Hewitt glass tube mercury vapor lamp..	6,800
Kerosene flame.....	1,946-4,380
25 watt frosted tungsten lamp, side.....	2,920
Candle flame.....	1,460-1,945
Gas flame (fish tail).....	1,314
10" opal ball, over 100 watt tungsten lamp....	306
Ceilings over indirect lighting fixtures (usual range, brightest part as viewed by occupants of room).....	73-4
Glass bowls used for semi-direct lighting.....	1,000-35

*Depreciation* due to dirt on glass and reflecting surfaces and to inherent characteristics of the lamps used must be recognized in design.

Both the total lumens and the lumens per watt of tungsten filament electric lamps drop with use, partly by the blackening inside the bulb and partly by disintegration and increase in resistance of the filament. Such lamps operated at the specific outputs shown in Table II, fall off in lumens output about 15 per cent. in 1000 hours service. With electric arc lamps and gas mantle burners so much

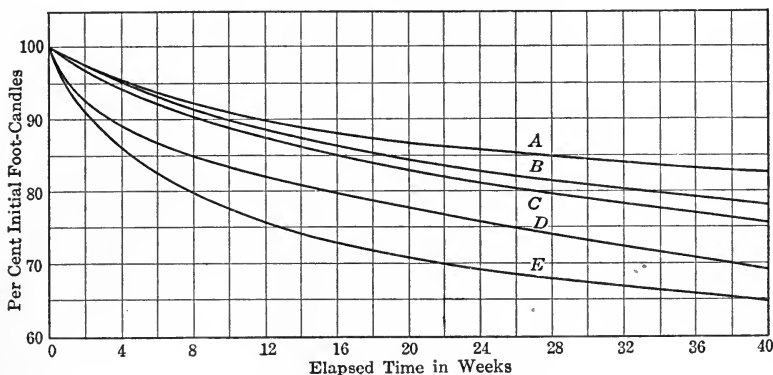

Fig. 2.—Depreciation caused by dirt.

depends upon the adjustment and other variable factors that no depreciation figure inherent in the lamp can be given, but unless maintenance is especially good more must be allowed than for the internal depreciation of the tungsten filament electric lamp.

The accumulation of dirt on the surrounding glassware and on the globe or reflector is an important cause of loss of light and should also always be reckoned with in preliminary calculations. It is necessary to assume some probable maximum depreciation figure from this cause and in making such an assumption of course the surrounding conditions and the probable frequency of cleaning must be considered. In Table V is given a compilation of results of various tests made in different places by different observers on the effect of the accumulation of dirt, and Fig. 2 shows the depreciation over an extended period for a given set of reflectors.

The effect of accumulation of dirt on side and ceiling windows is probably about the same as on lamps.

*Utilization of the Generated Light Flux.*—There are various methods of calculating the resultant illumination at the desired point with a

TABLE V.—LOSS OF LIGHT BY ACCUMULATION OF DIRT

Authority and reference	Conditions and surroundings	Lamps, globes and reflectors	Period covered by tests	Per cent. total decline for period	Per cent. decline per month
Durgin & Jackson, Trans. I. E. S., 1915, p. 707.	Down town Chicago office building dustiest rooms.	Semi-direct, dense bowls and tungsten lamps.	3 wk.	76	35.0
Aldrich & Malia, Trans. I. E. S., 1914, p. 112.	Office building in Chicago Stock yards.	Prismatic reflectors, satin finish and tungsten lamps. Direct.	12 wk.	25	8.5
Do.	Do.	Mirror reflectors and tungsten lamps. Indirect.	9 wk.	25	11.0
Do.	Do.	Opal bowl reflectors and tungsten lamps. Semi-indirect.	2 wk.	5	10.0
C. E. Clewell, Factory Lighting, p. 46.	Suburban factory office.	Prismatic, satin finish reflectors and tungsten lamp. Direct.	14 wk.	42	13.5
Do.	Do.	Prismatic clear reflectors and tungsten lamps.	17 wk.	17	4.5
Do.	Suburban factory.	Do.	9 wk.	28	14.0
Do.	Do.	Do.	11 wk.	29	11.5
Do.	Do.	Do.	13 wk.	40	13.4
Edwards & Harrison, Trans. I. E. S., 1914, p. 176.	Office corridor Suburban district, Cleveland.	Enclosing prismatic.	8 wk.	11	6.2

NOTE.—Since depreciation is more rapid at first, as shown by the curves the decline per month here given would not apply to longer periods.

NOTE.—For extensive additional tests see paper by A. L. Eustice, TRANS. I. E. S., 1909, p. 849.

given generated light flux. Before making such calculations it is of course important to reach an intelligent decision as to the points where the desired illumination is needed and whether it is best to consider the illumination measured in a horizontal plane, or vertical plane, or a plane in some other angle, suited to the particular requirements in question. Common practice in calculating and measuring the illumination in most interiors is to ascertain the illumination in a horizontal plane from 2.5 to 3.5 ft. above the floor, or about the height of desks, counters and benches. For the

majority of interiors this consideration of the horizontal plane serves the purpose sufficiently except for special localized lighting around machinery. If the illumination in the horizontal plane, commonly known as the "working plane" is to be taken as the criterion, it is possible to measure the average illumination in this plane over an entire room by measuring the illumination with a portable photometer at the center of a number of equal-sized rectangles into which the room may be divided. Dividing this average light flux by the light flux generated by the lamp gives what is known as the percentage efficiency of utilization, or utilization factor. Of course any other plane might be used for figuring efficiency of utilization provided the position of the plane were the position where the light was wanted. For example in an Art Gallery the efficiency of utilization might well be figured from the light flux incident upon wall spaces devoted to pictures and in a show window it would be figured from the flux through a curved surface corresponding to the line of trim of the window.

*The point-by-point method* of calculation (that is, if dealing in English units, dividing the candle-power by the square of the distance in feet to the point in question and multiplying this by the cosine of the angle of the incident ray to the surface in question to get the foot-candles incident illumination) is now chiefly used only for calculating the illumination at a few points from a single or small number of light sources. It is too time-consuming and laborious a method for the calculation of the illumination of large interiors with many light sources. It has the further limitation that it takes no account of reflection from ceiling, walls and floors and considers only the illumination direct from the lamp and its accessories.

The point-by-point method may be of considerable use in forecasting the differences in daylight illumination and at different points of interiors where the sky exposure and reflection coefficient of the buildings visible from any point in question are definitely known. The foot-candles illumination at various points as one proceeds back into a room from a window with unobstructed sky exposure may for the rough purpose of practical calculations be taken as inversely proportional to the square of the distance from the window to the given point. In applying this rule the fact should be kept in mind that frequently the window is far from an unobstructed sky exposure and that the sky exposure changes as seen from various points further back into the room. The effective exposure is the projected area of the sky seen by one looking at the window from the given point.

*A practical short-cut in the use of the point-by-point method* in calculating horizontal illumination which obviates the necessity of a table of cosines and makes possible calculations with only the aid of a polar candle-power curve of the light sources, is the following, which is a graphic method of applying the cosine factor. In the usual rule for getting horizontal illumination the illumination is equal to the candle-power at the given angle divided by the square of the distance multiplied by the cosine of the angle between the ray in question and the vertical. Now if we draw a perpendicular from the photometric curve at the angle in question to the vertical and take as the candle-power the candle-power scale reading at the point where this perpendicular intersects the vertical, we apply the cosine factor at the outset and by simply dividing this candle-power at the intersection with the horizontal, by the square of the distance the illumination is determined.

*In calculations of illumination by the zone flux method* all of the lumens emitted in a certain zone, say from 0 to 60 degrees or from 0 to 70 degrees, are figured as falling upon the working plane in the general lighting of an interior. This method, of course, takes no account of the uniformity of illumination and where approximate uniformity is desired must be used only with lamps and reflectors giving a type of distribution which will be sufficiently uniform. The zone flux method is chiefly applicable to illumination calculations with opaque reflectors where all of the flux is emitted in downward directions and little reliance is placed upon walls and ceilings to bring up the general illumination. Some industrial plants and foundries present such conditions. In the application of this method care must be taken not to select such a large zone as a basis that too much of the light strikes walls or other obstructions. At the same time in large interiors it is not necessary to confine the zone to simply those which would cover the floor near by. In show-window lighting if the reflector selected is such as to confine its flux to the plane it is desired to illuminate the method may sometimes be used for approximation.

*Empirical methods of calculation* based on actual experience and tests of existing installations form by far the most important basis for most calculations. With the other methods certain assumptions are necessary which may or may not be correct. With the empirical method based on experience, the only sources of error are those due to erroneously assuming conditions in the case to be calculated to be similar to those in the tested cases. Tables VI and VII and Figs. 3 to 9 inclusive give utilization factors or ratio of generated lumens to



TABLE VI.—UTILIZATION FACTORS

Ceiling, reflection coefficient	Light 70 per cent.			Medium 50 per cent.	
Walls, reflection coefficient	Light 50 per cent.	Medium 35 per cent.	Dark 20 per cent.	Medium 35 per cent.	Dark 20 per cent.
<i>Lighting Equipment:</i>					
Direct, Prismatic.....	65	61	59	58	56
	40	37	36	36	35
Direct, Light Opal.....	57	53	50	48	46
	33	28	27	26	24
Direct, Dense Opal.....	61	58	57	56	53
	40	35	34	34	32
Direct, Steel Bowl, Enamel or Aluminum.....	57	55	54	54	53
	39	36	35	35	34
Direct, Steel Dome, Enamel.....	70	67	65	67	65
	46	42	39	42	39
Totally indirect, Mirrored.....	40	38	36	27	26
	24	21	20	15	14
Semi-indirect, Light Opal.....	47	45	43	39	35
	30	25	24	22	20
Semi-indirect, Dense Opal.....	43	41	40	31	30
	27	25	22	18	17
Totally enclosing.....	46	42	40	38	35
Light Opal.....	25	19	18	18	15

The values in this table have reference to square rooms equipped with a sufficient number of lighting units and so placed as to produce reasonably uniform illumination. In each case the upper figure applies to an extended area, namely, one in which the horizontal dimension is at least five times the distance from floor to ceiling. The lower figure applies to a confined area, one in which the floor dimension is but five-fourths of the ceiling height. The utilization factor for a rectangular room is approximately the average of the factors for two square rooms of the large and small floor dimension respectively.

lumens incident upon the working plane for a number of typical conditions. A study of these tables shows the marked influence of size of room and ceiling and wall colors on efficiency. The figures on utilization factors Figs. 3 to 9 will hold for all rooms of the same relative proportions, as to shape, without regard to sizes.

## HYGIENE

The hygienic aspect of illumination is chiefly that of the effect on the eyes. It is also known that sunlight and other kinds of light having ultra-violet rays have a germicidal effect useful in killing disease organisms. There is also a psychological effect of light.

TABLE VII.—UTILIZATION FACTORS OBTAINED BY LANSINGH &amp; ROLPH

Page 586. Transactions I. E. S., 1908. Room 11.5 by 10.1 ft. high. All lamps at ceiling. Reflectors (where used) were of clear prismatic type.

	Ceiling	Walls	Floor	Per cent. utilization
1 Bare lamp.....	Dark	Dark	Dark	16.4
1 Lamp in reflector.....	Dark	Dark	Dark	31.6
1 Bare lamp.....	Light	Dark	Dark	29.4
1 Lamp in reflector.....	Light	Dark	Dark	42.0
1 Bare lamp.....	Light	Light	Dark	48.6
1 Lamp in reflector.....	Light	Light	Dark	55.0
1 Bare lamp.....	Light	Light	Light	60.0
1 Lamp in reflector.....	Light	Light	Light	79.0
3 Bare lamps.....	Dark	Dark	Dark	14.0
3 Lamps in reflector.....	Dark	Dark	Dark	26.0
3 Bare lamps.....	Light	Dark	Dark	26.0
3 Lamps in reflector.....	Light	Dark	Dark	34.0
3 Bare lamps.....	Light	Light	Dark	46.0
3 Lamps in reflector.....	Light	Light	Dark	50.0
3 Bare lamps.....	Light	Light	Light	56.0
3 Lamps in reflector.....	Light	Light	Light	66.0

The germicidal effect of sunlight has led to legislation requiring sunlight in living and sleeping rooms in some cities. It is evident, however, that an intelligent application of this to design requires considerable definite knowledge as to the amount of sunlight in a room which will cause appreciable germicidal effect and on this scientific evidence is still lacking.

As to the psychological effects there is a still greater need of definite knowledge. Points which may be considered psychological by some are taken up later under the head of æsthetic effects.

The eye is concerned chiefly with two things (*a*) sufficient brightness of visualized objects, resulting from sufficient illumination and (*b*) with the distribution of brightness within the entire field of vision.

Ordinary requirements for efficient vision are:

1. Sufficient quantity of steady diffusely reflected light from the object viewed.

2. Minimum flux of light emitted in the direction of the eye by specular or spread reflection from the objects viewed.

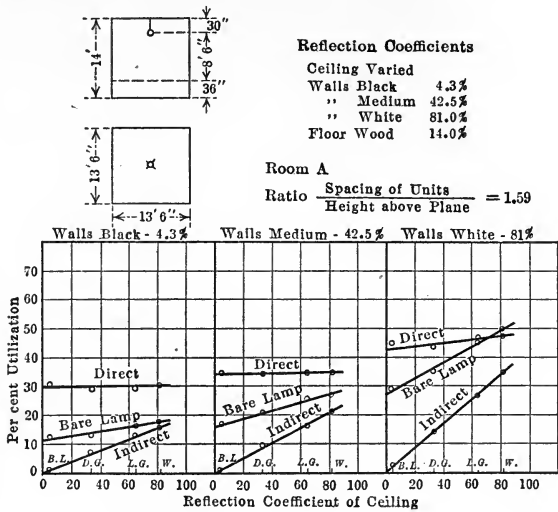

Fig. 3.—Utilization factors.

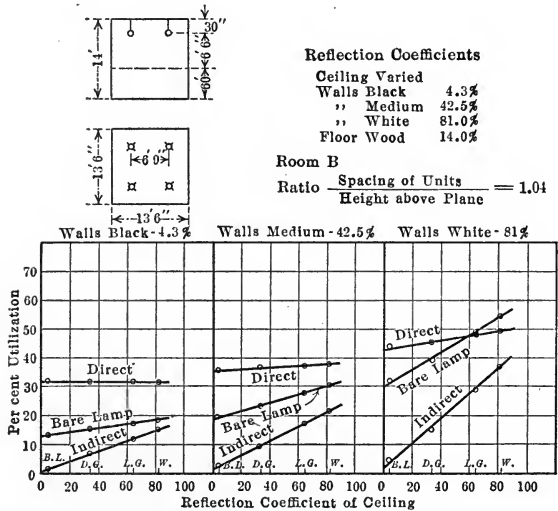

Fig. 4.—Utilization factors.

3. Absence of violent brightness contrasts within the field of vision.  
 4. Freedom from sharp shadows.

*Glare Defined.*—The 1915 Committee on Glare of the Illuminating Engineering Society in its report on Interior Illumination, page 36, I. E. S. Transactions, 1916, tentatively offered the following defi-

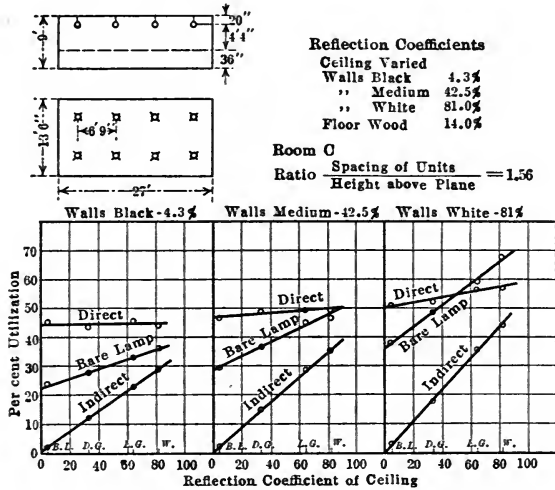

Fig. 5.—Utilization factors.

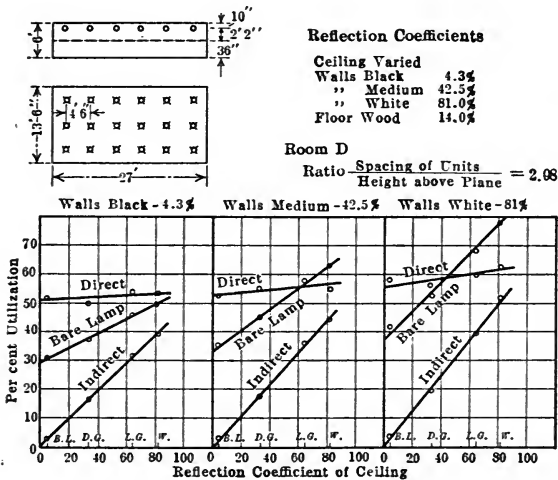

Fig. 6.—Utilization factors.

nitions which express more definitely than heretofore attempted what constitutes glare. Three alternative definitions were offered as follows:

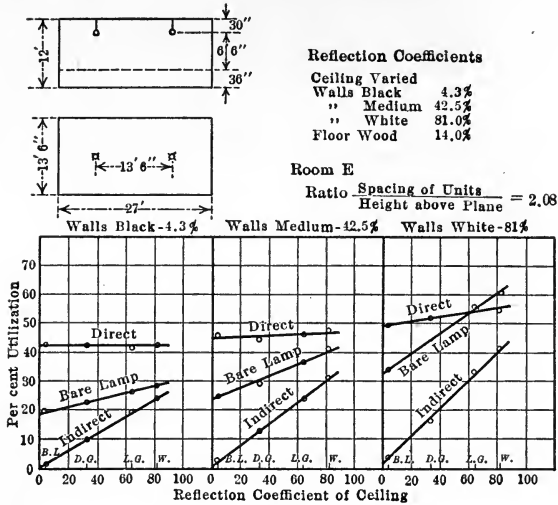

Fig. 7.—Utilization factors.

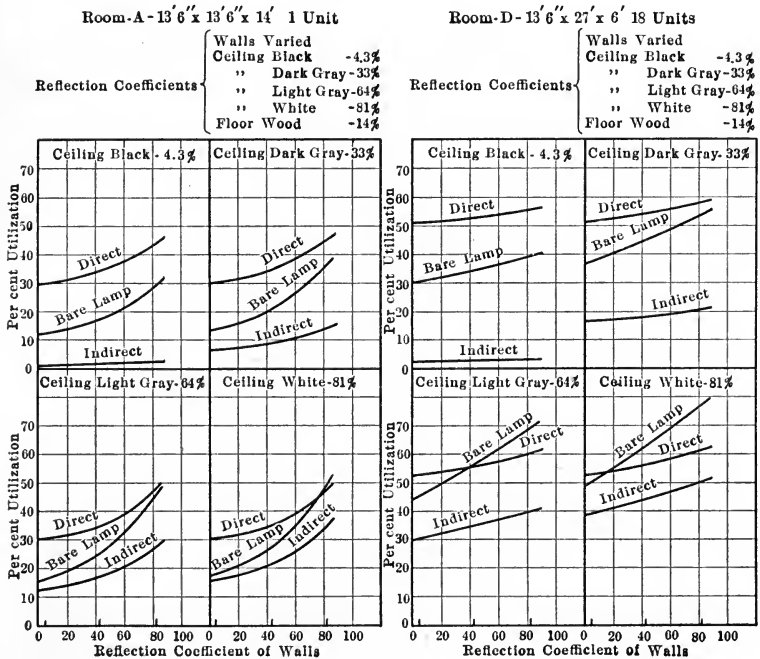

Fig. 8.—Utilization factors.

Fig. 9.—Utilization factors.

*Glare.*—1. Brightness within the field of view of such excessive character as to cause discomfort, annoyance, or interference with vision.

2. Excess brightness of or flux of light from the whole or any portion of the field of view, resulting in reduced vision, fatigue or discomfort of the eye.

3. Light shining into the eye in such a way, or of sufficient quantity, as to cause discomfort, annoyance or interference with vision.

Contrast glare is a kind of glare commonly experienced in defective lighting of interiors. That is, the contrast between the brightness of the sources of light and other objects in the visual field is so great as to cause discomfort, annoyance or interference with vision. As far as we know there is no measurable interference with vision when the glaring bright source of light is removed 25 to 30 degrees away from the center of vision. It may, however, cause discomfort, annoyance and eye fatigue if it is anywhere within the visual field. Therefore while a design which removed the lamp more than 25 degrees from the ordinary range of the center of vision might be satisfactory as far as measurable interference or reduced ability to see is concerned, it might not be satisfactory to work or live under continuously because of the fatigue and annoyance resulting.

A review of all of the available data and observations of cases where eye fatigue and annoyance have been complained of together with numerous eye fatigue tests by the Ferree method indicates that to avoid glare effects visible light sources should not be more than 200 times as bright as their background and preferably not over 100 times, in ordinary artificial lighting of interiors where the average illumination of the working plane is from 3 to 6 foot candles. As most of the tests on this point have been made at about this magnitude of brightness it is not entirely certain what ratio should be adopted for other magnitudes, but from tests made by Nutting (I. E. S. Transactions, 1916 Convention) on the lower limits of annoying glare (which limits of brightness are of course much higher than for fatiguing glare) as well as from certain well known common experience there is reason to believe that for higher illuminations than 6 foot candles this limit of contrast should be less than 100 to 1 while for lower limits it may be more than 100 to 1.

Brightness for bowls and globes for locations where they are continuously within the field of vision, with from 3 to 6 foot candles on the working plane should be kept approximately below 300 millilamberts in rooms with light-colored (50 per cent. reflection coefficient) walls to

safely conform to the 100 to 1 contrast limit. The brightness should be diminished as the reflection coefficient of the walls is decreased. Outdoors where brightness magnitudes are much higher it is worth while noting that contrasts do not often exceed twenty to one; while at night, outdoors, much greater contrasts are well known to be tolerable.

*Brightness glare* is glare due to an excessive general brightness of the field of view. It is seldom experienced in interior illumination except possibly from the reflection of sunlight from a sheet of white paper.

*Temporary glare resulting from flicker* is a condition caused by the lack of brightness accommodation of the retina of the eye to such sudden changes in brightness.

*Specular reflection or veiling glare* from glossy paper, polished metal work and the like are very common conditions with all systems of lighting and are likely to be especially pronounced with artificial illumination, from relatively small sources. The polished surface reflects a glaring image of the source of light. The actual brightness of the glare on the paper as far as it can be measured is not likely to be over 1.5 times that of the background but this seems to be enough to make trouble in this location though it would hardly be noticed elsewhere. Frequently the ink or pencil marks on paper have more specular reflection than the paper and in the glare positions these marks may be equally as bright as the paper, and hence invisible or nearly so.

*Shadows* may cause interference or trouble with work if the illumination in the shadow is insufficient or if the contrast between the parts in shadow and those out of the shadow makes the shadowed places appear dark by contrast. Shadows caused by bright light sources with direct lighting have sharp edges and may cause annoyance while an equal shadow with a large source of light or indirect lighting where the transition from the middle of the shadow to the edge is gradual may not be perceptible except to the expert.

Shadows are to be most carefully considered in large office and factory spaces lighted by general lighting, where the location of the work with reference to the light cannot be adjusted or changed and the illumination must be sufficiently good at any point in any position to permit of efficient work.

The ratio of illumination in the shadow to illumination just outside of the shadow with large sources or indirect light may be as high as one to two without causing annoyance provided the illu-

mination in the shadow is sufficient for the purpose in hand. Because of the nature of these shadows with indirect lighting the ordinary person is apt to think there are no shadows and to attempt the closest work in the shadows of his head and body, not realizing that the illumination is better away from this shadow. With the sharper shadows common to direct lighting systems this would not be the case. However, owing to the sharpness of these latter shadows the same shadow ratio might sometimes cause some annoyance.

In a large room with a number of lighting units the actual magnitude of the shadow, that is the ratio of illumination in the shadow to that out of it, is likely to be about the same with an indirect system as with a direct, provided the spacing of the outlets is the same in both cases. The direct lighting shadows have sharp edges, however, which makes them easily apparent where the others are not.

*Quantity of Illumination.*—It is customary to discuss problems concerning the quantity of illumination required for different purposes in terms of the illumination incident upon the work. This incident illumination, however, is the cause which produces the desired effect, namely, brightness of the object viewed, and it is this effect that is the real end desired. Table VIII calculated by Dr. P. G. Nutting from work by König and himself shows the sensibility of the eye

TABLE VIII.—EYE SENSIBILITY AT DIFFERENT MAGNITUDES OF SURROUNDING BRIGHTNESS

P. G. Nutting

	Average brightness magnitudes, millilamberts	Perceptible percentage difference in brightness
Exterior, daylight.....	1000.0	0.0176
Interiors, daylight.....	10.0	0.030
Interiors, night.....	0.1	0.123

at different typical brightness magnitudes. As a matter of fact of course the brightness magnitudes of interiors both at night and day vary considerably from the average brightness value given. From this table it will be seen that increasing the illumination one hundred fold from a rather poor lighted interior at night to an interior by daylight makes the eye able to perceive a percentage difference in brightness about one-third of that it is able to perceive in the former case. This gain is apparently rather small but if the eye is working near the limit it may be important.



The eye sees by virtue of differences of brightness and color. The question of a sufficient quantity of illumination for a given kind of work is not altogether that of delivering a certain number of foot-candles on a certain plane where the work is being done. The question is fundamentally one of producing a sufficient contrast of brightness for the eye to perceive readily objects with a given brightness of surroundings. In the case of reading printed or written letters on paper we have a considerable contrast between the paper and ink or pencil which makes them easy to distinguish with any kind of illumination which does not produce specular reflection or glare from the paper or ink, provided the illumination is of sufficient quantity. In the case of sewing on either dark or light goods there is very little contrast between the thread and the goods so that the problem of producing sufficient shadows and specular reflection to enable the thread and the texture to be seen easily is important. For this purpose localized lighting coming mainly from one direction is necessary.

Many tables have been published of the intensity of illumination required for various purposes but all should be used with allowance for the fact that color and direction must be considered as must also the general brightness of the surroundings. The latter is especially true when there is a large window exposure but the particular spot to be illuminated does not get the benefit of the window illumination.

The indications of scientific research so far are that the eye works best when the object upon which vision is centered is of about the same general magnitude of brightness as the surroundings. This is what one might expect from the conditions under which the eye has been evolved.

Table IX shows the approximate foot-candles illumination considered about right by a number of authorities for various classes of interior lighting.

The question of proper quantity of illumination for reading has been investigated much more thoroughly than that for other purposes. Tests show considerable difference between individuals although the same individuals show consistent repetition of the quantities considered sufficient. If the direction and diffusion of light is such as to cause veiling glare from the paper or ink more illumination is required although it cannot be said that with veiling glare present it is ever possible to produce as satisfactory and comfortable illumination, no matter what the intensity, as can be obtained with veiling glare practically absent.

TABLE IX.—ILLUMINATION FOR VARIOUS PURPOSES

	Foot-candles
Reading: U. S. Government Postal Car minimum requirements.....	2.8 Note <i>a</i> .
Clerical and office work.....	3-7
Drafting.....	5-10
Drafting, tracing on blue prints or faint pencil drawings....	10-20 Note <i>b</i> .
Factory work, coarse.....	1.25-2.5 Note <i>c</i> .
Factory work, fine.....	3.5 -10 Note <i>c</i> .
Corridors.....	0.25-1
Stores, ordinary practice.....	3-7
Stores, first floors, large cities.....	5-10 Note <i>d</i> .
Audience rooms.....	1-3
Show windows.....	5-4c Note <i>d</i> .

NOTES.—(a) Some individuals are satisfied with half this while others, especially the aged and those not properly fitted with glasses and those whose eyes are sub-normal for any reason may be satisfied only with values considerably higher than this; perhaps 5 to 10 foot-candles. When such individuals are to be satisfied this fact must be remembered in the design.

(b) Illumination from below is preferable, using a translucent table.

(c) Depends also on color.

(d) Depends on surrounding competition.

As a result of extensive tests of postal clerks and others on the light required for reading under postal car lighting conditions the United States Government now specifies a minimum illumination of 2.8 foot-candles at points where reading of letter addresses is to be done by postal clerks.

There is no conclusive evidence at the present that there is any marked hygienic advantage in color of one artificial illuminant over another. This statement refers to purely physiological results rather than to æsthetic effects. An exception to this which should be noted, however, is that there is good evidence that the chromatic aberration of the eye causes a certain lack of clearness with most natural and artificial illuminants so that for seeing fine details a light which is nearly monochromatic like the mercury-vapor light is preferable.

### ÆSTHETIC EFFECTS

It is not the function of this portion of the lecture to give a dissertation on art but rather to call attention to methods by which certain desirable effects can be produced and undesirable ones avoided.

The function of illumination is to provide light and shade, as it is artistically called, on various objects. From the standpoint of appearance much depends on how the light and shade are regulated or in more scientific language upon the direction and diffusion of the light. By diffused light is here meant light coming from many directions or from large surfaces like the sky or illuminated ceilings. Much of the pleasing or displeasing effect of a design of interior illumination depends upon the proper use or misuse of shadows, and tastes differ decidedly as to what light and shade effects are most pleasing. Heavy shadows are produced by light coming mainly from one direction with very little general diffused light. While for some particular purposes extreme contrasts are considered desirable by some persons, others think them to be unpleasant. It is possible to eliminate shadows so completely by having light coming from many directions that there remains only the difference in the coefficient of reflection of different parts of the illuminated object to enable the eye to distinguish it. If the object is a piece of white statuary or moulding of uniform color and reflecting power, perfectly uniform or diffuse illumination will obliterate all details.

Direct lighting systems with small sources produce sharp shadows like those produced by sunlight. With indirect lighting systems and semi-direct systems with very dense glassware the shadows are very similar to those obtained from skylight. They differ from window daylight in direction when the ceiling is the main reflecting surface, but if the wall is the main surface window direction and diffusion is imitated. Sky- and window-light shadows are gradual transitions from light to dark.

Exposed light sources have been used for many years for decorative effect and will doubtless continue to be used. It is for the illuminating engineer to recognize this fact and to guide the use into the proper hygienic channels. With the tiny sources of light available up to the introduction of electricity and gas mantle burners the bad effects of glare with decorative lighting of this kind were not much felt. With the brighter and more powerful light sources now common, adequate shading precautions must be taken. The bare light source of to-day is not only hygienically bad but it is so crude as to be unartistic. There are so many opportunities to produce pleasing effects with diffused light by the use of colored glass, cloth, or paper shades, leaving the main light for useful purposes to be obtained in other ways that there is no longer much excuse for the type of fixture which in spite of its great expense offers nothing better for light

diffusion than a lot of loosely hung prisms interspersed with bare lamps.

In the use of lamps for decorative effects the same rule as to low brightness values should be adhered to as is laid down under the head of hygiene. The lamp shade or globe which must be faced continually should be not more than 200 times as bright as its background, and no light source of this kind should be bright enough to be annoying or noticeably glaring.

Although white daylight cannot be said to have an unpleasant effect on countenances it is notable that among lamps, those which give light yellowish in color rather than those offering considerable green and blue are the most pleasant. Red and yellow light bring out the agreeable color of the face while the absence of those colors and prominence of blue and green give the countenance a ghastly hue.

There is some difference of opinion as to how far red and yellow and amber colors should be sought in light, especially in residence lighting. Some even go so far as to color the tungsten lamp purposely to get nearer the yellow color of the old carbon lamp. However, this result can also be obtained by the use of ceiling and wall colors and proper glassware. If indirect or semi-indirect lighting is used, the color of the ceiling has much to do with the resultant illumination in the room. The ceiling can be so tinted as to make the room illumination as yellow as desired. The small amount of illumination which should be allowed to come directly through the bowl of a semi-indirect fixture should not have much effect in the general total.

A very yellow light like that of the old carbon incandescent and open gas flame or more modern illuminants with yellow globes brings out certain yellowish hues in decorations and paintings so as to give a richer effect than would be obtained with white light. At the same time it must be remembered that these are deficient in green and blue and the green and blue in paintings and decorations suffer accordingly. Either the decorations should be suited to the color of light or the color of the light to the decorations. As to which course should be pursued depends entirely on the particular conditions of the case.

At the present time almost any color desired in artificial lighting can be obtained with a sufficient expenditure of money. Where it is desirable to bring out all of the colors as in daylight several methods are open. The Moore carbon dioxide tube lamp and the intensified carbon arc lamp uncorrected give practically white light. The gas filled tungsten lamp and the gas mantle burner with a special mantle

can be used with a glass having the proper selective absorption to filter out the excess of certain colors and give a white light. The same process can be used with other yellow illuminants. Since this process involves throwing away the excess yellow over and above that needed to maintain a proper balance for white light it is, of course, somewhat wasteful.

In considering the question whether art may clash with hygiene and utility, it may be appropriate to ask whether anything can be considered artistic which is unhygienic and ill-suited to the use for which it is intended. Nevertheless it may be proper to mention some points where so-called art and comfort and the health of the user may clash. When an architect designs an interior so that nothing but exposed glaring lamps on brackets will satisfy his idea of the artistic one is tempted to ask where the art comes in as far as the user of the room is concerned. When an audience room or council chamber is finished in dark colors with elaborate chandeliers of a design which permit of nothing but a great quantity of glare one is again tempted to make the same inquiry. Cases can be cited without number where the ideas of some person as to what is artistic are given precedence over health and comfort. There are no reasons why these three elements cannot be combined.

## PART II. THE PROCESS OF DESIGN

The process of illumination design usually consists of the following steps:

1. Selection of the general scheme of lighting, and the type of lighting units.
2. Calculations of the quantity of light flux required.
3. Final selection of the location and size of the lighting units.

In making each of these steps we must fall back upon the basic information given in Part I.

*The selection of the general type of light source* must, of course, depend on the kind of lamps available. This depends on local conditions and need not be discussed here. Then the hygienic and artistic requirements and limitations should be considered.

Both the electric incandescent lamp and the gas mantle burner are adapted to the illumination of almost any kind of interior from the roughest to the most refined. For the illumination of offices and industrial plants there also comes up for consideration the mercury-vapor lamp. For some of the roughest industrial plants such as foundries and steel mills the flame arc lamp can also be considered,

although in offices and stores the fumes emitted are not allowable. The color of the light from the mercury-vapor lamp, of course, is an objection from the artistic standpoint although hygienically no case has been found against it. For work on fine black and white detail the better visual acuity it gives tends to offset the psychological effect of its color.

In choosing between the tungsten electric and gas mantle burner lamps the following points must be considered for each case:

(a) The cost per 1000 lumen hours for electricity *versus* gas at the current prices. In making such comparison allowance should be made for the probable depreciation of the lamp below the laboratory performance figures given in Part I. In the case of electricity there is a blackening and increase in resistance in the lamp internally and the accumulation of dirt externally to cause depreciation, and in the case of gas in practice the burner adjustment is seldom as good as that obtained in the laboratory and there is the possibility of worn and defective mantles. These depreciation figures can easily lower the electric lamp output by from 20 to 50 per cent. below laboratory figures and the gas lamp output to by from 30 to 60 per cent. below the laboratory figures. Of course, the engineer should take into account the maintenance conditions that are likely to exist in the completed installation. The better the maintenance the lower the necessary percentage allowance for depreciation.

(b) The relative convenience of control under the two methods. If the gas installation is to be arranged for a control practically equivalent to that of electric, the comparative total cost of the two systems should be considered.

(c) Additional blackening of ceilings and walls with gas as compared to electricity should be weighed against the cost of electricity along with the cost of gas.

(d) The probable relative steadiness of the two illuminants under the particular local conditions under consideration. The voltage of the electric system may be very unsteady and the pressure of the gas very steady or the reverse.

(e) The cost of glassware and lamp renewals for electric lamps and the cost of glassware and mantle renewals or maintenance service for gas lamps should be figured.

No illuminant should be chosen which does not permit the use of the proper globe, shade or reflector equipment to conform to the hygienic requirements spoken of later.

*Glare Elimination.*—The necessity of the elimination of glare de-

pends largely on the purpose to which the room is to be put. In a living room or a general office or an audience room where persons sit for long periods in one position it is of first importance to avoid glare in the eyes of the occupant. On the other hand if the eye is not to be exposed to the glare for long periods, some temporary glare is permissible in many cases to keep down the cost of construction and operation.

Glare may be kept from the eyes of the occupants of a room by limiting the brightness contrast ratios to which the eye is subjected. In the case of artificial light this is done by inserting opaque reflectors or a diffusing medium between the lamp and the possible positions from which it can be seen.

Practically all sources of artificial light now in common use are too bright for continuous exposure to the eye with the background illuminated no better than is common practice to-day.

In eliminating glare by the insertion of diffusing glass or other material between the light source and the eye three general methods have been used. An opaque reflector or one of dense translucent glass, cloth or paper can be placed over the lamp far enough to protect the eyes of occupants of the room and yet allow direct light from the lamp and reflector to fall on objects under and near the lamp. Another method is to reverse this process, putting opaque or dense translucent reflectors under the lamp to reflect the light to a light colored ceiling or wall and so obtain a diffused light from the ceiling or wall. As the light is spread out on the ceiling its brightness is comparatively low and the brightness contrast ratios are cut down to bring them within the limit of tolerance of the eye. A third method is to put around the lamp an enclosing globe that will diffuse the light going in all directions. While this is a very common method it is an incomplete solution of the problem of the most modern illuminants because a diffusing globe which will cut the brightness down to a proper figure is either so large as to be prohibitively expensive or so dense as to cause a prohibitive loss of light.

The second method, that of using indirect lighting, or semi-direct lighting with bowls of very low brightness, is the only reasonably economical and practical method which conforms fully to the hygienic requirements in most cases where low brightness of the units is required. Even if the ceiling is dark in color it may be more feasible to light the room indirectly from a dark-colored ceiling than to put in enough outlets to supply general illumination from the enclosing globes.

A method which partially eliminates glare, adopted in many cases in which indirect lighting would be considered too expensive on account of the poor reflecting qualities of the ceiling, involves the use over the lamps of reflectors deep enough to hide most of the source of light, the lamp being placed as high as possible to get it out of the ordinary range of vision. This method is extensively employed both with translucent reflectors of various types of opal and with opaque reflectors of white enamel steel, aluminum-finished metal and mirrored glass. This method is necessarily an incomplete solution of the problem of eliminating glare because it is possible to see the lamp filaments, mantles or frosted tips of the lamp and the interior surfaces of the reflectors, any of which is bright enough to cause contrast glare. It is however much more efficient and less glaring than the use of bare lamps or flat reflectors.

In the lighting of industrial plants where the ceilings are considerably broken up and not very white, and in large rooms of the coliseum or armory type with high roof and open roof trusses, the operating expense of indirect lighting would be usually considered prohibitive, and the method of using bowl reflectors of various depths with lamps placed high is the most common in the best practice to-day.

Opinion differs somewhat as to whether the bowl reflectors used in this way should be opaque or translucent like opal. Opaque reflectors have been extensively used partly because of the greater strength of the opaque metal reflector and partly because it was felt that light striking such dark colored ceilings would be so largely wasted that a reflector directing all of the light flux below the horizontal might better be used. The latter is a mistaken view. A dense opal reflector directs as much light flux below the horizontal as a good white enameled reflector, so that the light passing through the opal reflector to light the ceiling and upper walls represents clear gain. Illuminating the ceiling and upper walls reduces the contrast glare, makes the room more cheerful, and adds to the diffused light.

In an armory or a coliseum type of building there is another method of partially reducing the contrast glare effect which combines some of the elements of the methods previously mentioned. This is to use reflectors of an extra deep bowl type confining most of the light flux within about 40 degrees of the vertical. This of course reduced the number of light sources which are within the field of vision at one time and those sources which can be seen are near the edge of the visual field. With such deep reflectors a mirrored sur-



face is more necessary to the exact control of light and high efficiency than where the reflectors are shallower. The reflector should not be too concentrating or the illumination on vertical surfaces will be poor.

Along with this plan of using deep reflectors in buildings of this type it is frequently considered desirable to provide for some illumination of the roof and upper walls to reduce the contrast glare effect between the illuminated interior at the lower part of the reflector and the roof background. This can be done by providing indirect lighting for the roof from separate lamps and reflectors but is most easily accomplished by simply allowing enough light to escape out of the top of the deep reflector to illuminate the roof.

The avoidance of glare with natural lighting from side and ceiling windows is partly a matter of the proper selection of window glass, louvres and shades but it is also very much dependent upon the general arrangement and color scheme of the room.

Diffusing glass of various kinds such as ribbed, prism, frosted, corrugated and roughed glass have been used to some extent to increase the illumination in a room (as already explained in Part I) and may do this very effectively if they are kept clean. In the application of such glass care should be taken not to place diffusing glass below the eye level. In an ordinary type of window where the sill is much below the eye level the lower sash should not be provided with diffusing glass. The effect of diffusing glass is to receive light from the sky and transmit it by diffusion into the room. The result is a great increase in brightness of the lower window, to such an extent that the brightness is much greater than that to which the eye is accustomed in such a location. While the eye is accustomed to the brightness of the sky and clouds above a horizontal plane it is not accustomed to such a high order of brightness below the horizontal plane. Although it is occasionally subjected to it when outdoors with sunlight on snow or on white macadam roads or desert sand all of these conditions cause eye discomfort.

It is quite possible for the architect to render glare unavoidable either by night or by day and so defeat all later attempts at good lighting. Conditions are more easily controlled as regards artificial illumination, however, than as regards natural illumination. In the case of artificial illumination, interiors with a very dark finish with corners where there is a small amount of illumination introduce large contrasts which are uncomfortable, if lighted by ordinary methods with exposed lamp or lamps with enclosed globes. Such

interiors can be lighted by the expenditure of sufficient luminous energy upon dark ceilings and walls to bring up the general illumination to a satisfactory point. This method, however, is not in accordance with the general scheme of design of such interiors. The only method of treatment of such interiors which is satisfactory and is in accordance with the general architectural scheme is the use of localized light from thoroughly shaded sources and this usually means that there must be a large number of sources.

In the case of daylight illumination from windows, one of the principal things to be avoided is an architectural arrangement which makes it necessary for persons to be seated facing windows with a bright sky visible through the window in contrast to a dark space around the window. Facing the window may not be objectionable when seated very near to the window so that the sky occupies a considerable portion of the field of vision but as one recedes into the room the sky occupies a smaller portion of the visual field and in painful contrast with it are the walls of the room which are very much less bright.

In office work the direction of diffusion of light has much to do with the amount of glare from papers on desk tops. Daylight coming from windows at one side of the desk gives the best working conditions, partly because of the large diffusing surface (the sky) from which the light comes and partly because of the fact that it comes from one side so that all of the veiling glare on the paper is in a direction where it is not often observed by the worker.

The most effective method of eliminating veiling glare in office work with either daylight or artificial lighting is the use of nothing but matte or soft finish paper. Of course this is not feasible in most cases at the present time. Under present conditions such glare can be eliminated only by so placing the source of light that the angle from the source to the paper can never equal the angle from the paper to the eye. Under these conditions the only veiling glare present is that due to a reflection from the paper of the moderate illumination from the walls and ceilings. Such a position is usually only feasible with a drop cord or wall bracket lamp placed at one side and slightly back of the worker. With any kind of local desk lamp near the work it is difficult to avoid glare from the paper altogether as there are so many positions from which the light can be received. Furthermore with either a desk lamp or a wall bracket lamp properly placed for one worker, direct glare from the lamp, or glare by reflection from the paper, is almost sure to be experienced by other

workers in the room. With indirect lighting for general office work a slight amount of veiling glare consisting of reflection of the ceiling from the paper is received in many working positions but this is not so serious as the glare with the other arrangements described.

Complaint is sometimes made that daylight and artificial light do not mix well in color or direction and that there is a period at dusk when there is likely to be trouble with an artificial lighting arrangement that is satisfactory after dark. This trouble is usually due simply to insufficient artificial light for the best work, but is sometimes further aggravated by the presence of sky areas visible to the worker but shaded from the work. In the latter case the eye is adapted to the sky brightness rather than the desk top brightness.

As already seen most of the available modern light sources are very bright. In order to conform to the hygienic requirements, if the reflectors or shades used are not opaque, they must at least be dense. Semi-direct lighting usually requires a bowl which is rather thick, not only to withstand the mechanical strain but to give a sufficient thickness of glass to cut down the brightness. Various glass mixtures have been compounded for such bowls. Some of the blown glass bowls for this purpose consist of two or three layers, forming what is technically known as a cased glass. Specific limitations for bowl brightness have already been noted.

From the efficiency standpoint the prime requisite for a semi-direct lighting bowl is a pure white highly polished interior surface which will give a high percentage of reflection from its surface and a sufficiently dense glass medium so that the light that is not reflected shall be considerably reduced in brightness.

In the manufacture of heavy diffusing glasses of this kind there is much opportunity for development of pleasing artistic effect by the use of tints and coloring. To most people yellowish tints are more pleasing than those of blue or green.

The eyebrows of the average person shade the eyes from rays falling as near perpendicular as 25 degrees from the vertical or less, but for rays emanating from light sources above this angle artificial shading must be provided if the lamp is overhead. If the edge of the lamp shade is below or near the level of the eye any kind of shade which will intercept all rays above the horizontal will protect the eye.

With daylight illumination it is common for window curtains and draperies to cut off about 50 per cent. of the total light and for the roller shade to be left where it will cut off from 30 per cent. to 40 per cent. of the remainder. Large effective window areas in pro-

portion to the size of the room are conducive to the most hygienic daylight conditions. Dark curtains or draperies around the edges of a window tend to increase the contrast glare effect. The brightness of the sky seen through the central part of the window is not changed by such draperies and the total illumination in the room is materially changed so that the contrast between the sky and the interior surface of the room is increased. Practices of this kind should be discouraged for hygienic reasons. For similar reasons large window spaces are desirable. Legislation for schoolroom construction frequently names a window area of from  $\frac{1}{6}$  to  $\frac{1}{5}$  of the floor area.

In selecting a window shade it is well to consider the purpose for which the shade is most likely to be used. A dark dense shade is frequently objectionable for shutting out sunlight in an office building, factory or schoolroom because it shuts out altogether too much light. If a very dark shade is used to shut out sunlight, a small area of brightly illuminated space is left near the window while the rest of the room is in strong contrast to this bright space and the effect is to introduce contrast glare and make the illumination of the room seem insufficient. Moreover, such a preponderance of brightness below the eye level is unnatural, as before explained, and will of itself cause discomfort if sufficiently pronounced. If on the other hand, use is made of light colored window shades which allow considerable diffused light to pass through, the illumination sent back into the room is not so seriously interfered with when they are pulled down and the contrasts of brightness within the room are not so great and the whole effect is more comfortable and hygienic.

Having selected a general type of lighting source to be employed and the lamp equipment to be installed the next step is the selection of the exact size and location of the lighting units. Two general characters of problems are presented in practice. One of these is where the general illumination is desired within minimum and maximum limits and the other is where the principal consideration is a local illumination of a certain intensity without much regard to the quantity of illumination elsewhere in the room.

In problems of the latter class where the illumination at some particular point is the main thing desired, the point-by-point method of calculation has its advantages. If it be assumed that a certain number of foot-candles illumination is required at a certain point this illumination multiplied by the square of the distance in feet will give the candle-power which must be emitted from the unit in that

direction. The general type of unit and its shading equipment having been already selected it then becomes a matter of determining what size of lamp will most nearly give the candle-power required at that particular angle. This is done from photometric curves of the lamp equipment. If curves are not available for all sizes of lamps that can usually be calculated with sufficient approximation from curves made with one size of lamp.

Most of the problems however are those requiring a certain average general illumination. The selection of such an average however always implies that the minimum in the working area shall not fall too far below the average. In modern practice it is comparatively easy to keep this minimum within 25 per cent. of the average with proper design. Having assumed the average illumination required and assuming also that the spacing to be selected will be such as to give a reasonable degree of uniformity the next step is the calculation of the total light flux required to be generated by the lamp. Using the empirical method. This is obtained by the simple formula

$$\frac{ia}{e} = L$$

Where  $i$  equals foot-candles average illumination upon the working plane.

$a$  equals area of the working plane in square feet.

$e$  equals the efficiency or utilization factor or percentage of lumens generated which become effective upon the working plane with the lamp equipment and room conditions under consideration.

$L$  equals the total lumens to be generated by the lamp.

In the foregoing formula,  $ia$ , of course, equals the total lumens effective upon the working plane.

In applying the foregoing formula of course the important thing is to select the proper value for  $e$ , the efficiency or utilization factor. This can best be done by consulting the various tables and curves of utilization factors, Tables VI and VII and Figs. 3 to 9 or any other good authority and selecting conditions which most nearly correspond with those in the room under calculation. In applying these factors they should be reduced by the amount corresponding to the depreciation due to dirt and age of lamp. Such depreciation figures for various conditions have already been noted.

If the value of  $e$  is not obtainable from experience and use is to be made of opaque direct reflectors,  $e$  can be determined for most large interiors from the distribution curve of the lamp and reflector

by dividing the total lumens emitted by the lamp by the lumens emitted in the zone from 0 to 70 degrees. For smaller rooms a smaller zone should be used.

Having determined the total lumens required to be generated by the lamp by the foregoing formula there remains the determination and decision as to how this total flux is to be divided, or in other words the sizes of the lamps and their locations.

In most cases there are certain natural divisions of the rooms by ceiling panels or other architectural features so that it is necessary in the interest of good appearance to make the lighting outlets symmetrical with reference to these panels. The ideal condition to be sought after is to divide the ceiling into a number of squares with an outlet at the center of each square. Frequently it is not possible to do this, but it is well to maintain the divisions as nearly squares as possible. In other words if an oblong division is necessary long and narrow rectangles should be avoided.

*Height.*—To secure proper uniformity either with indirect light or with direct lighting reflectors giving the most extensive type of distribution the height of the sources of light should not be less than half their distance apart, taking the height of the sources of light as the height of the ceiling in the case of indirect lighting and as that of the lamp in the case of direct light. Spacing at shorter intervals than the maximum permissible is desirable both in the case of direct and indirect lighting in order to secure greater uniformity, freedom from annoying shadows, and a reduction in the amount of specular reflection or veiling glare from papers and polished metals. Shorter spacing is imperative if concentrating direct reflectors are used.

When the spacing has been determined in a way which will fit in symmetrically with the architecture and at the same time answer the uniformity requirements, the number of outlets is ascertained and this number, divided into the total lumens to be generated by the lamp, gives the lumens per lamp. From the proper up-to-date manufacturer's information the lamp size most nearly answering the requirements must be selected.

Indirect fixtures should be hung a sufficient distance from the ceiling to avoid a very spotted lighting effect. The nearer to the ceiling they hang the greater the concentration of light under the fixture.

#### EXAMPLES OF THE PROCESS OF DESIGN

The following typical examples on the process of design are given to illustrate the principles that have been laid down.

*Example 1.*—A large room area 100 by 100 feet with 14.5 foot ceiling used for general office purposes and clerical work, having light colored walls and ceilings. The entire area is covered by desks and filing cases. Since practically the entire room has to be illuminated sufficiently for working purposes, localized lighting is not to be considered except possibly for a few billing machines having lamps on portions of the machine that might be in shadow. In order to avoid glare the system must be indirect or nearly so, so that the semi-indirect with very dense bowls will be selected, as the office is of a prominent concern where the decorative effect of the illuminated bowls is desirable. As it is necessary to seek first the highest efficiency of the employees (as saving in the consumption of energy for lighting would be a very small percentage of the amount spent for pay-roll) the lighting intensity should be such as to be beyond criticism or question as to sufficiency. An average illumination of 6 foot-candles will, therefore, be selected with the understanding that the minimum is not to fall below 4.5.

From the utilization factor table we see that a large interior of this kind has a utilization factor of about 48 per cent. before allowing for depreciation and dirt. We will allow 15 per cent. depreciation by dirt on electric lamps and reflectors, and assume that the system of cleaning and maintenance will be such that this will be a maximum figure. We will also allow 10 per cent. depreciation for falling off in luminous output of the lamp. This gives a total figure of 25 per cent. to be allowed for dirt and depreciation in service, so that our 48 per cent. utilization factor is reduced to 36 per cent.

The room having a floor area of 10,000 square feet, multiplying this by 6 foot-candles average illumination gives 60,000 lumens required on the working plane. 60,000 lumens divided by 36 per cent. gives 166,600 lumens to be generated at the lamps. Taking up the spacing of the lamps we find the room divided into bays  $20 \times 20$  feet and as those bays are not too large to give good uniformity with an outlet in the middle of each bay with this ceiling height we will put an outlet in the middle of each bay. With this division 25 outlets will be required. The total 166,600 lumens at the lamps divided among 25 outlets equals 6660 lumens per lamp. The nearest sizes to this in electric lamps are the 400-watt 6150 lumen lamp and the 500-watt 8050 lumen lamp. In gas lamps an inherent depreciation figure of 20 per cent. more than the electric had probably better be assumed. An output of 325 lumens per

cubic foot per hour less 20 per cent. equals 260 lumens. Twelve inverted mantles taking 2.5 cu. ft. of gas each per hour would then give 7800 lumens.

The size of lamps having been determined, the bowl can be selected for the semi-direct lighting fixture of a glass having a density preferably such that the bowl brightness will not be over 300 millilamberts, as that will not be over 100 times as bright as of the 3 millilamberts on the wall illuminated to about 6 foot-candles. The brightness of a wall in millilamberts equals the incident foot-candles times 1.07 times the coefficient of reflection of the wall.

*Example 2.*—A small office room 10 feet wide and 10.5 ft. high by 20 feet deep with light ceilings and walls, typical of thousand of rooms in large office buildings. The character of the occupancy cannot be predicted but the usual arrangement is desks near the window facing each side-wall. These desks may be either flat or roll top. Another possible arrangement is to place the desks so that the back of the worker is to the window. There would also probably be a typewriter desk farther back in the room, usually along one of the walls. The building is to be provided with electricity only for lighting. The two plans for artificial lighting for such an office which must naturally receive consideration are the following:

A, General lighting, supplemented by local desk lighting. B, General lighting for all purposes without localized lamps. The economy of modern lamps has done away with much of the necessity of using localized lighting for the sake of economy as formerly. For most office work localized lighting is not as satisfactory as general lighting, because of the veiling glare from papers, etc. However, if general lighting is depended upon alone use must be made of a system which will not cause annoyance from shadows.

If this is in a typical modern office building it is desirable to have as few outlets as possible on partitions as the occupancy and location of partitions may change. If general lighting is to be accomplished from ceiling fixtures centrally located a system indirect or nearly so will provide for most contingencies in variation of desk location, etc., and if the desks are located facing each wall the shadows of heads will cause the least annoyance. On account of the importance of reducing the shadows to their lowest terms an indirect system will be selected, rather than semi-direct. The office can conveniently be assumed as divided into squares each 10 by 10 feet and an outlet located in the center of each square. This arrangement provides for ample illumination of the rear of the room



farthest from the windows. On account of the possibility of shadows and veiling glare being more annoying with only two sources of light and with the possibilities of workers being seated with their backs to the illuminated ceiling so as to cause maximum shadows, more light should be provided at the lamp per square foot of floor area than in the case of the general office in Example 1. However, if there were only one desk in the room and that located directly under a lighting unit the reverse would be true and less light would have to be provided, because the maximum light would be received directly under the outlet.

In this case, therefore, we will allow for an average illumination of 7 foot-candles which may fall to 4 or 5 foot candles along the walls in shadows. Seven foot-candles times 200 square feet equals 1400 total lumens to be generated and delivered upon the working plane. The efficiency of utilization in such a room will probably be around 29 per cent., which, when reduced by 25 per cent. for dirt and lamp depreciation as in Example 1, would mean a factor of 22.5 per cent. The 1400 lumens needed divided by the 22.7 per cent. equals 6600 lumens to be generated at two outlets or 3300 lumens per outlet. The nearest single lamp to this in output is the 2800-lumen, 200-watt lamp. Since we have been rather liberal in our allowances as to the foot-candles required at the start the use of this lamp would be permissible.

If a room of this type were a little wider it would be best to have two rows of fixtures in spite of the spacing rule given because of the desirability of minimizing the shadows at the desks near the walls.

*Example 3.*—If the general office of Example 1 were an industrial plant having the same dimensions but with a darker, more broken up ceiling the method of treatment would be the same except that deep bowl opal reflectors or opaque shallow or deep bowl reflectors might be used. The utilization factor would be changed and perhaps more allowance should be made for dirt.

*Working Out Cost Comparisons.*—In making comparison of operating and maintenance cost for different illuminants or systems of lighting the following items should enter for any given period.

- (a) Cost of energy or fuel (electricity, gas, oil, etc.).
- (b) Renewals of lamps, lamp parts or burners (mantles, lamps, trimmings, etc.).
- (c) Cost of cleaning lamps and accessories.
- (d) Cost of cleaning or redecorating walls and ceilings.
- (e) Interest and depreciation on cost of system in building.

## PRINCIPLES OF EXTERIOR ILLUMINATION

DR. LOUIS BELL

Exterior illumination is, speaking broadly, the generalized case of application of artificial light. In interior lighting, that applied, for example, within the limitations of a room, the light flux is confined within the bounding surfaces where it is subject to reflection and absorption, the amount of which has to be taken into rigorous account in reckoning the final result in lumens available for service. There are no such restrictions necessary in exterior lighting since its problems have to be dealt with chiefly in terms of the radiant unlimited by artificial boundaries. In general the case is that of a luminous source required to produce a certain flux density on a single arbitrary plane which may be horizontal, as in the case of street lighting, or vertical, as when one illuminates the façade of a building. In rare instances one deals with both a horizontal and one or more vertical planes simultaneously, as when light is directed into a street or public square of limited extent, but there is always one general direction and more commonly several in which no limiting surfaces are interposed and the solid angles pertaining to which must be regarded as representing regions of complete absorption.

The use of reflectors with exterior illuminants is merely an effort to limit this absorption angle by the partial interposition of a reflecting surface effective roughly in proportion to the solid angle which it subtends from the source. On this point of view it is immediately evident why in employing such reflectors their equivalent solid angle is a matter of great importance, so that it frequently happens that the last few inches of radius on a reflector determine whether it is to be good or bad in redirecting the light. Further, whether one or more bounding surfaces must be taken into account in planning for exterior illumination, the effect on the conditions of illumination is altogether different from that found in interior lighting. Here the surfaces are frequently fairly light so that they present low coefficients of absorption. One surface, the ceiling, is almost always light and one, the floor, is generally dark, but no darker, however, than the ground which serves as the working plane in exterior lighting. In this latter case, one works under serious disadvantages in the appli-

cation of the light, since the surface to be illuminated is usually rather dark with high absorption. The remainder of the surfaces toward which light flux is directed are practically also of high absorption, save in exceptional cases, so that one cannot depend in exterior lighting upon that measure of assistance often equivalent to an increase of from 50 to 100 per cent. in the effective flux.

One is generally dealing out of doors with directed light flux from the radiant somewhat modified by the shades or reflectors that may be applied thereto, and as a rule only one or a few such radiants have to be considered. Hence the numerical computations in the case of exterior lighting are fairly simple, and the working out of exterior problems is rendered fairly easy by the fact that the intensity of illumination demanded is generally less than with interior lighting and the conditions with respect to uniformity are also considerably less severe. Within doors the illumination demanded is determined by the things which have to be done by its aid and some of these are tasks which require close vision on unfavorable details, so that common intensities of illumination run all the way from 10 to 50 lux (1 to 5 foot-candles), and in rare instances much higher. In exterior lighting, save for deliberately scenic purposes, 10 lux is rarely exceeded and the usual standard intensities run from about 0.5 to perhaps 5 lux (0.05 to 0.5 foot-candle). Broadly, in exterior lighting the conditions of distribution are less favorable than in interior lighting, but the requirements of intensity and uniformity are much less severe.

The amount of illumination required in exterior work depends on its use, but this is never such as to call for illumination good enough to facilitate the observation of fine detail. At most one may have to read a program or an address card. Ordinarily it is sufficient to distinguish people and vehicles easily, to note obstructions on the roadway or sidewalk, to recognize persons and things at a moderate distance, and perform other simple tasks requiring no close discrimination. One recognizes objects on road or sidewalk chiefly by their shadows. If their color tone be nearly that of the road surface they are almost invisible, except when so illuminated as to show a shadow. One also sees at night the contrast of light and dark masses, like the silhouette of a cart against an illuminated roadway, or of a white-clad person against a hedge or fence. The eye, therefore, is not called upon to do any fine work and hence does not require a degree of illumination sufficient greatly to develop its full discriminatory powers.

Only in such exterior work as has to do with the deliberate illumination of particular objects, as in some spectacular lighting, is it necessary to push the intensity near to the point common in interior lighting. This is fortunate since with immense spaces to light and unfavorable conditions as regards reflecting surfaces exterior lighting is only economically possible in virtue of the modest necessities of the case. Luckily the human eye works about equally well for the purpose of seeing over a very wide range of illumination. From the full sun shine of noon to twilight, the illumination may vary in the ratio of 1000 : 1 and yet the eye can do most of its work comfortably at either extreme. It is not the absolute amount of light which counts, but the relative amount as between two things to be discriminated. Speaking in general terms one can distinguish as varying in shade two adjacent surfaces, the illumination of which varies by a little less than 1 per cent., whether the actual intensity of the lighting be of the order of magnitude of 10 or 1000 lux. A contrast of 10 per cent. is conspicuous even when the illumination falls much below 10 lux. The power of the eye to discriminate both shades and small details even in black and white falls off rapidly under ordinary visual conditions, so that at a few tenths lux (or hundredths of a foot-candle) even a contrast of 25 or 30 per cent. between surface and surface may not be easily visible unless the surfaces are on a very large scale, and one fails to read even very coarse type. In such lighting obstacles are difficult to see, persons difficult to recognize and, while one can still see to move about, the conditions are bad if any traffic is to be considered. Such is the situation even in pretty good moonlight which may run to say from 0.1 to 0.25 lux (0.01 to 0.025 foot-candle).

One of the many valuable properties of the eye is that it possesses, however, an extraordinary power of adaptation, that is, of getting used to great variation in the intensity of the lighting and still being able to see fairly well. It may be light-adapted, as when the pupil shrinks to its minimum diameter, and the eye adjusts itself to a very bright light, or it may be dark-adapted, when the pupil opens very wide and the retina itself becomes adjusted to conditions of very low illumination. This latter process is largely a physiological one which requires some little time to accomplish, but it is tremendously efficient. After ten or fifteen minutes in complete darkness, for instance, the eye is many hundred times more sensitive to faint illumination than in its light-adapted condition, and as a matter of fact with this long dark adaptation the same

keenness of discrimination which ordinarily exists at 10 to 50 lux may be found even at a hundredth of this amount. This is particularly true as regards vision of surfaces differing slightly in illumination, less true for the observation of detail like printing.

It is for this reason that one can see much better by moonlight, to which one gradually gets adapted in the absence of other illumination than is possible with artificial lighting where one continually comes under the more intense illumination near lamps. The power of adaptation of the eye, therefore, rises to considerable practical importance in external lighting. If dark adaptation is not spoiled by glaring sources of light one can see astonishingly well at low illumination. Hence under lighting conditions where one has to work with a meager amount of light, a source which would be entirely unobjectionable in the case of the brilliant illumination found, for instance, in a public square, becomes unpleasantly glaring and unfits the eye for good vision. This is what happens when one drives an automobile under a low hung and brilliant street lamp. The vision must again adjust itself to the less brilliantly illuminated regions, only to get another rebuff from the next lamp.

This would look as though uniformity in lighting roads and other large areas might be very important. Its value is lessened by the fact already referred to, that is, that we see objects, generally, in a moderate illumination, chiefly through their shadows. A perfectly uniform low illumination, could it be attained conveniently, would be good from the standpoint of adaptation and bad from lack of contrast due to shadows. The contrast directly under a strong light source may be actually much less than in a faint light directed cross-wise so that the visible contrast is not between the object itself and its surroundings, but between its shadow or shadowed parts and the surroundings. These facts were very beautifully brought out in experiments tried a couple of years ago for the National Electric Light Association.

For most purposes of exterior lighting the best results are obtained by lamps rather well shaded, so as to reduce the intrinsic brilliancy of fairly good power, and so located as to produce only a moderate amount of uniformity in the resulting illumination. In situations where the intensity for one reason or another must be considerably increased, the value of directed light as against flat uniformity is very considerable. The front of a building, for example, can be flattened distressingly by too uniform lighting or brought out with brilliant effect by a little judicious cross-illumination, a condition

precisely analogous to that found in the interior lighting, for instance, of a church, in which the high altar requires oblique illumination to bring out its relief. The same practical application of contrast appears in that class of exterior illumination which has to do with decorative and spectacular illumination of places or things.

Now and then most remarkable effects can be produced by close attention to regulating the quantity, quality and direction of the light applied. This is on a large scale exactly what is done in the setting of theatrical scenes where effects of spaciousness or of distance are produced upon the very limited area of a stage. Brilliant and uniform illumination tends to give an effect of nearness and lack of relief. Faint and carefully directed lighting on the contrary may be made to produce an effect of vague distance. When many light sources are in view a decreasing spacing gives a spurious effect of distance, uniform or increasing spacing from the foreground back, the reverse effect. Lamps of decreasing brilliancy along the line of view likewise produce an impression of far perspective, while increasing brilliancy gives an illusion of nearness. The cases where these principles need to be applied are not common enough to justify going into the matter to any great extent, but most astonishing results can be reached in the way of forced perspective wherever scenic effect is desirable.

The problems encountered in exterior lighting are of a very diverse character involving many different sets of conditions, each of which must be met in a systematic and definite way. One can divide the total roughly so that each group possesses somewhat similar characteristics, for instance, perhaps the simplest case of exterior lighting is that of a public square which presents a somewhat close analog to certain types of interior lighting. Here, as a rule, from the nature of the surroundings and the density of the traffic, the illumination has to be considerably higher than usual, rising even to 10 or 20 lux (one or several foot-candles) and averaging therefore almost as high as certain interiors. A square roughly approximates a large and not very high interior having a very dark ceiling and side walls of rough texture and very varied reflecting power. For all practical purposes the sky above is almost completely absorbing, while the entering streets take the place of a few great windows, from which practically no light is reflected, but which may receive a little from the outside, that is, from down the street. If such a square is illuminated from sources provided with over head reflectors having angles wide enough to intercept rays which pass above the

house tops, the full downward flux from all the lamps may be considered as concentrated on the walls and floor. Absence of ceiling reflection somewhat diminishes the amount of aid given to the general illumination by secondary reflections. If then, we know the efficiency of the reflector system which keeps the light from going skyward and therefore the total downward flux of the lamps, the illumination on the working plane can be reckoned practically as in a case of interior lighting. In the latter case suitable reflecting systems will turn quite half the total light flux from the sources upon the working plane, from which, knowing the area, the average illumination can be found at once by a process which will be outlined later. The uniformity of the lighting will be determined by the number and place of individual radiants and the light curve derived from each. A pure flux method leads to the general average illumination, a point-by-point method to the maximum and minimum.

Second on the list comes street lighting, so important that it will be dealt with in this course by special lectures. Here the interior analog would be a very long hall with a black ceiling and it is usually necessary to determine the illumination by considering the effect of individual radiants, since they are seldom close enough together to require the addition of the luminous effects from more than a very few lamps. As a rule the average lighting of a street, except in the case of one carrying very heavy traffic, does not require the intensity desirable in public squares. Indeed the necessary illumination in certain classes of streets may fall to a point where the lamps are little more than markers of the way. Only in densely built regions can any gain be counted upon from reflection from sides of buildings which, however, it is sometimes desirable to light rather brightly for the general effect. As the lamps are usually placed considerably lower than the buildings the solid or spherical angle subtended by the reflector, if there is one, may be considerably less than in the case of large open spaces.

Next in order comes the lighting of building exteriors which in the case of public squares and of streets is incidental rather than primary. The lighting of the façade of a building for utilitarian or decorative purposes or the lighting of a public monument is a case of direct illumination, in which the light from one or more reflecting systems is concentrated on a definite area, be it large or small, to produce specific results over that surface. In the same category falls the lighting of spaces like railroad yards, docks and

work of construction. Such lighting may have to rise to a brilliancy as great as or greater than, that desirable in public squares, or may fall to the average of rather mediocre street lighting according to the purpose intended, but in all cases it is directed for special rather than general results. It requires ordinarily lighting units equipped with reflectors of comparatively large spherical angle, so as to direct a large percentage of the luminous flux, and if the properties of the reflectors are approximately known the results can be calculated, as will be presently shown, very easily, by a simple flux method.

Finally, one has to meet the special conditions imposed by parks and other very large open spaces. These are peculiar in that no help can be received from any lateral surfaces and in that conservation of resources demands generally so small an amount of illumination that the preservation of suitable dark adaptation in the eye becomes of paramount importance. Only now and then is high intensity desirable and that only locally, where the lighting may assume something of a decorative aspect.

To take up in more detail the illumination necessary in these different cases the highest limit is touched by the lighting of public squares. In such areas, which are generally centers of streets carrying dense traffic, the average illumination on the reference plane, three or four feet above the ground, should be as shown by experience, one or several lux (a few tenths of a foot-candle). In some cases it has been pushed even to 10 lux over a considerable area. The exact density required is evidently determined by the nature of the situation, but any average less than one lux (0.1 foot-candle) must be regarded as undesirably low. In practice the average should generally run to at least double this amount in order to preserve a suitable minimum while using only a moderate number of lighting units. Certainly anything less than 0.5 lux must be regarded as unsatisfactory as a minimum figure and it is not easy to secure in a large area this minimum without having an average exceeding 1 lux, and a considerable area of maxima of at least double this amount. One needs to see well in a public square where many people congregate and many vehicles pass, and the amount of illumination must therefore be pushed to a high limit with some special effort at uniformity in order to prevent the appearance of dark areas in the general effect. Likewise in such situations the buildings deserve more than the usual illumination since they are commonly of importance and of decorative value when properly lighted.



As in every case of exterior illumination the actual amount of light to be furnished in a public square depends on the nature of the situation. The figure just given ought to be regarded as an irreducible minimum for areas in which there is any considerable amount of traffic even of pedestrians. Where vehicles are frequent and the space generally more crowded it is necessary to increase the illumination considerably, rising as high perhaps as 5 lux or more under extreme conditions. Large open areas through which a continuous stream of street cars, automobiles, and pedestrians are pouring, particularly in the evening hours, can hardly be too strongly illuminated for safety and convenience.

The method selected to provide the illumination depends intrinsically on the particular area to be dealt with. As a general rule the lamps, whatever their size, should be carried relatively high in order to secure a fairly even light distribution without going to an abnormal number of supporting structures. It is a good rule to keep a public square as free of lamp posts and other obstructions as possible, which indicates the wisdom of avoiding a multiplicity of small lamps and of utilizing a few tall standards which may be given a high decorative importance and lead to a simpler and more effective installation. In a few instances where the open area is large and the traffic is chiefly around its margin, lamps carried on the curbs as in ordinary street lighting prove to be the best sources of distribution. In a case of this kind the light should be where the traffic is, and consequently the lighting of the center of the area can be reduced in intensity while that on its bounding streets should be correspondingly increased. For simplicity of installation and efficiency of light production large units are desirable in this as in every case of a requirement for brilliant illumination. Arc lamps of 1000 or 2000 candle-power or incandescent lamps of nearly or quite equivalent candle-power lend themselves readily to this particular use. They should always, of course, be enclosed in diffusing globes, and it should be remembered that the gas-filled incandescent lamp is almost as glaring as an unshielded arc. If in such a square there are any important monuments, as sometimes happens, the illumination should be directed high enough to include them. There is no need here to deal with the details of calculating the illumination, since this subject has been admirably handled in a previous lecture. Broadly the problem can be attacked along two related lines.

First, the area and the desired illumination gives at once the effective lumens required to obtain the average result. It will

generally be found that the figure thus given is a minimum since the ordinary criterion of proper illumination considers not alone the average but also the minimum so that the required light flux must be distributed so as fully to meet the minimum requirement, when incidentally it will carry a somewhat high maximum. The simplest way of solving the problem is to determine from the general light flux required the type of unit which will be desirable to use, that is, one not so large as to involve great difficulty in proper placement or so small as to require undue multiplication of supports. From the polar candle-power curve of such a unit the equi-luminal lines corresponding to the minimum permissible illumination can be plotted for various heights of placement and then these areas arranged so as to overlap enough to insure keeping comfortably above the minimum at all points. With ordinary light-sources and reflecting equipment one will rarely select a height of placement less than 30 ft. in open squares, although this figure may be somewhat reduced in cases where the margin of the area is the chief region of traffic. As a rule the more powerful the unit the higher it may be advantageously placed.

As to whether single or multiple units should be used on a single standard, the decision is chiefly a matter of taste. With the large incandescent lamps in particular the efficiency varies very little with output so that one may freely use standards carrying two or more lamps at comparatively slight loss of efficiency. Clusters are generally not to be recommended since the several globes with their supports are in each other's way; moreover, the low lying clusters, which have been frequently used in the past, are seldom either efficient or artistic. In so-called ornamental lighting both arc and incandescent lamps are generally mounted much too low for efficient light distribution, a few distinguished exceptions like the recent exposition lighting at San Francisco to the contrary. The rule of artistry in the lighting of public places is to keep the lamp carriers in scale with the general architectural environment and to place lamps of sufficient candle-power to give the necessary result in illumination approximately as here indicated. There is a particular need of studying such problems in lighting since they cannot well be solved by the ordinary apparatus of street lighting, placed, as it is, usually along the curbs near to the façades of buildings, and designed to be at its best in illuminating a rather narrow street. The public square is a place by itself as regards the requirements for illumination.

In street lighting proper the chief area of illumination is that of the street surface itself where the vehicular traffic is located. Secondly, sidewalks and crosswalks must be adequately lighted, and finally, where the building line is near the street, the fronts of buildings themselves cannot be left out of consideration; first because they need to be lighted for the general effect; and second, because they may, if light in color, add something to the general effectiveness of the street illumination. The commonest mistake made in street lighting is to follow a uniform method and type of illuminant irrespective of the individual needs of the street. A very common method of lighting in the earlier days consisted in placing at each street intersection, irrespective of the length of the block or the character of the street, an arc lamp, usually of insufficient candle-power. This gave a fine uniformity of lighting units, but extremely bad illumination except in parts of the city where the intersections were very close together. The almost inevitable result later has been the thrusting of incandescent or gas lamps into the intermediate spaces, finally producing a mixture of kinds and sizes of lamps both bad in appearance and unsatisfactory for the purpose intended.

If a street is to carry dense traffic for a considerable period each night, that street requires thoroughly good illumination, as good even as the better class of public squares. If the traffic is not heavy and pedestrians are occasional, vehicles are chiefly to be considered, the same degree of lighting is totally unnecessary as well as wasteful. An active business street for this reason, even if not of the first class, demands brighter illumination than an ordinary residence street, and this in turn better illumination than a suburban road. Speaking generally the minimum requirement for street lighting is that demanded for proper policing, the maximum, that required for active business accompanied by dense traffic after darkness falls. The attempt to illuminate all streets in approximately the same way and to about the same amount means that if the important streets are really well lighted a great deal of waste will occur in the unimportant ones, or if the illumination be standardized for the latter the former will suffer greatly. One of the most difficult tasks in arranging the proper illumination of a city is to bring the public to the appreciation of the fact that light is for general civic service and not for the uniform distribution of lighting expense through every mile of street or every ward and precinct.

In his own practice the speaker customarily divides streets into

first, second and third class, with respect not to the popular idea of their merits or the cost of the buildings upon them, but strictly on the basis of the needs disclosed by their use during the hours of darkness. For the purpose of lighting, a first-class street may be a boulevard leading through the center of the city and containing many of the important business houses, or a street running along the water front, congested with vehicles and streams of humans, or even a side street through which from one necessity or another a great volume of traffic passes.

A second-class street may be a side or subsidiary street of business houses, a residence street of fine mansions, a back street of swarming tenements or a long road running out of the city but constituting a main avenue of automobile traffic. The third-class streets will form the residuum after the first two classes are well marked out, the ordinary rank and file of city and suburban streets not much frequented, and never at all congested.

Most first-class streets are thoroughly obvious except for those which form short cuts or for some particular reason are crowded after nightfall. These, however, are easily discovered by a very brief investigation of traffic. The second-class streets require more skill in selection. Some of them suggest themselves at once, but a conference with the chief of police will usually open up the situation in a very interesting manner, and it is just at this point that the greatest difficulty in satisfying the public occurs. It is not polite to tell the alderman of the Nth ward that a couple of shabby streets in his district needed to be extremely well lighted on account of the semi-criminal character of his constituents, while the quiet residence street on which he lives may be relegated to the third-class. Personally I have tried to make a practice of extending good second-class lighting to all regions of churches and schools and other districts where for one reason or another the streets might be much used at night. Some singular anomalies may be found in making classifications. For example, an active business street down town, which at first thought would be put in the first class, may turn out to be very little used after dusk and so be relegated to the second. The proper classification is a matter of tact and local study.

It is sometimes wise to add a fourth group of streets and roads to those already mentioned, in which the street lamps are hardly more than markers of the way. Almost every town has running out of it long roads not heavily populated, but which still are main lines of traffic to neighboring districts. To light these even as a third-

class street should be lighted is uneconomical, but a very modest equipment indeed may work great improvement in the traffic conditions. It is extraordinary how much even small lamps widely spaced will do to assist traffic on a dark night. To use the lamps as markers rather than for illumination then becomes practically a rather important measure of public convenience, although from the standpoint of light flux the provision may seem almost a practical joke. Some engineers attempt even a somewhat further subdivision, having in mind a gradation between the second and third class, but it is not generally necessary, since there is trouble enough in establishing a sound basis of classification in even three groups.

As respects the actual amount of illumination required for street work the figures given depend on the agreement as to the way in which this illumination shall be measured. Abroad it has been the custom to reckon the illumination as the total received upon and resolved upon a horizontal reference plane usually taken as a meter above the ground. This means that the light received from each source must be resolved according to the cosine law on the plane and the total received from all the sources added. In American practice it has been the custom to reckon the illumination as that received from one direction only upon a plane normal to the ray. On account of the obliquity of the illumination the former method generally gives a lower numerical value for the illumination, a fact which must be borne in mind in interpreting foreign specifications. For the special case in which only two lamps are considered, spaced at four times their height, the numerical results will coincide by the two methods and such relations of spacing to height is not uncommon especially abroad.

For street lighting proper, the writer prefers the usual American method on the ground that the most trying tests of street lighting in practice, such as reading an address, or recognizing a person, do not depend upon supposing either page or person to be extended flat upon the ground, but do depend on the light that fairly strikes them from the lamp. Either method of reckoning is perfectly safe provided it is consistently used.

Based on the usual American reckoning the illumination in first class streets should run nearly or quite as high as in public squares, that is, should amount to a minimum of at least 0.5 lux (0.05 foot-candle) and preferably double this amount, with an average two or three times as great. The chief streets of well-lighted foreign cities before the war averaged fully up to this standard. Indeed I

have often taken as a rough test of the proper illumination the ability to read a Baedeker when walking or riding along the street, that excellent volume being utilized merely as one generally at hand. First-class streets differ among themselves to a considerable extent, but if the minimum is kept up to 1 lux the maximum will usually run high enough to give an average of from 2 to 4 lux with a maximum anywhere from 5 to 20.

In street lighting the difference between the minimum and maximum illumination is generally conspicuously great. Any ratio less than 1 : 10 requires very special efforts to secure uniformity and streets which are practically very well lighted indeed may show ratios of 1 : 25 or even 1 : 50. In such instances the darkest spots will usually be very small in area and due to special circumstances and the average will be high. Streets here designated as second-class ordinarily require about half the intensity ascribed to first-class streets, that is, an average of 0.5 to 1.0 lux. Third-class streets, again, may have advantageously about half the intensity of the typical second-class streets, with the proviso that anything as low as 0.25 lux as an average would unquestionably bring a minimum so low as to be almost negligible midway between lamps. Finally where street lamps are used merely to mark the way the illumination will be so small except near the lamps as to be hardly worth considering, the function of the lamps being to define rather than to illuminate the road. A committee appointed a few years ago in London to make recommendations as to street illumination drew up the following recommendations:

Classification of streets	Minimum horizontal illumination in foot-candles
Class A.....	0.01
Class B.....	0.025
Class C.....	0.04
Class D.....	0.06
Class E.....	0.10

which correspond pretty closely to that here suggested.

The class E streets of this table correspond to the first-class streets just described, classes C and D include the second-class streets, and classes A and B the third-class. Bearing in mind the difference in the conventional measurement the results are of practically the same order of magnitude.

Variations in intensity such as here required depend on two things, the height and the spacing of the illuminants and, other things being equal, the diversity ratio between maximum and minimum depends on the relation of the height to the spacing. Powerful light sources need to be placed high in order to avoid both too great difference between maxima and minima and too great obliquity of the more distant rays. Small lamps may be placed correspondingly lower and also require closer spacing to meet the minimum requirements. With big units approximating 1000 candle-power the height of placement should be not less than 25 ft. to obtain the most useful distribution of light, while the smaller units either electric or gas are usually most effective when placed from 15 to 20 ft. high with the spacings ordinarily employed. Occasionally, in using particularly well-screened large units closely placed in order to obtain a very powerful illumination, the figures here given may be somewhat reduced, the point being to adjust the spacing with reference to the direction of maximum intensity, so that this may fall nearly at the midway point between lamps.

Extreme uniformity of illumination is in general not worth the effort in street lighting, the main point being that for streets carrying any material amount of traffic the minimum illumination must be high enough to give reasonably good results. This matter will be taken up in the lecture dealing with the technique of street lighting, so that I need not further mention it here except to say that there is definite evidence of too great uniformity tending to prevent the quick vision of obstacles, and also tending to lessen the attentiveness, for instance, of the driver of a motor car. This point was admirably brought out in the psychological work done under the direction of Prof. Munsterberg for the N.E.L.A. street lighting tests.

As to the conditions of placement of street lamps the main practical factor is the nature of the street. A narrow street, particularly if well built up, may be admirably lighted in the usual manner by placing the lamp posts upon the curb. A street much shaded by trees loses too much from shadows with this positioning and use must be made of long brackets, mast arms, or cross suspensions, in this country usually the mast arms. Very broad streets sometimes can be advantageously lighted by means of a row of posts down the center perhaps on isles of safety, in extreme cases in conjunction with curb lighting as well.

A word here with reference to glare from street lamps, which sometimes becomes very unpleasant, especially with high efficiency

illuminants. Lamps mounted high are in general much less troublesome than those placed low, and even when powerful light sources so placed fall well within the field of vision at the midway point between them, the gross intensity of the light reaching the eye is so considerably reduced as not to be serious. One does not particularly mind the glare from even a very powerful arc at 200 or 300 ft. distance, while it may be most offensive when nearer. In fact it is not always easy to tell at long range whether a high power lamp has or has not a diffusing globe, but in either case the light does not produce serious glare. Even the smaller lamps now used for street lighting, especially the almost universal high-efficiency incandescent lamps, which are often placed low, may produce very offensive glare and seriously hinder the utilization of the illumination derived from them. Certainly in the larger types of these lamps the use of frosted bulbs or thin diffusing globes is highly desirable and proves of practical benefit.

Passing now from street lighting, of which the details will be fully set forth in a separate lecture, we come to a rather special case of illumination, namely, the lighting of public monuments and the façades of buildings. I will not here enter at length into the technique of this matter since it will form part of the subject matter of another lecture of this course, but will merely point out some of the general requirements and the means for meeting them. Where the façade of a building is to be illuminated the method employed has to depend on the character of the building and its distance from available situations for lamps. Sometimes suitable ornamental lamp posts with powerful illuminants may be placed on the curb of a wide sidewalk, fairly high, in such position as to give an admirable effect in lighting the front of a building. In cases where this is not feasible and yet for one reason or another good illumination of the façade is desired the modern projector using high-intensity incandescent lamps meets the requirements with admirable effect. The difficulty here is the proper placement for the lamps, which can seldom be found on the building itself and more generally has to be sought on opposite or near-by roofs. The same conditions hold for the task occasionally required, of lighting public monuments. Many of these had better be left under the concealing wing of night, but occasionally a fine example appears which fully deserves all the attention that can be bestowed upon it.

This again is a case for flood lighting which can rarely be carried out from the base of the monument or the immediate vicinity. It



usually required a suitable placement of the lamps at a distance several times the height of the monument. As reflectors for incandescent lamps can now be obtained which give a fairly concentrated beam, a suitable point of attack can always be found, even if it has to be a couple of hundred feet away. It is, in fact, rather easier to get a projector with a fairly narrow beam than it is to obtain one with a beam of moderately great angle, well distributed and concentrated, but progress is now being made to assure good results in almost any condition that can be found.

I will not here go at length into the topic of flood lighting, but will content myself with pointing out that with such reasonably exact knowledge of the reflecting system as should be at hand in any well designed commercial lamp it is a perfectly simple matter to calculate the wattage required to produce any given amount of illumination which circumstances demand.

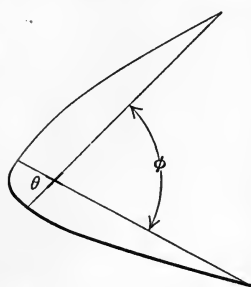

Fig. 1.—Beam candle-power.

In doing this I shall merely amplify the outline of the theory which I gave in the Baltimore Lectures of six years ago, applying the added data which are now available.

Consider a source,  $x$ , placed in the focus of an approximately parabolic reflector. All the light within the spherical  $\angle \phi$  passes out in a scattered secondary beam. The primary beam delivered by the mirror takes the light from an  $\angle 4\pi - (\phi + \theta)$  and is diminished by the absorption and scattering at the mirror surface. Let the beam fall normally upon a surface producing a circle of illumination of radius  $r$ . Then

$$E = \frac{4 \pi w \eta}{\pi r^2} = \frac{4 w \eta}{r^2}.$$

Or, if the circle is projected into an ellipse,

$$E = \frac{4 w \eta}{ab}, \text{ as average.}$$

Here  $\eta$  is the specific efficiency of the source *in its reflecting system* and  $w$  is watts used,  $\eta = \sigma \rho \kappa$ .

Where  $\sigma$  is the specific output of the source in spherical candles per watt,

$\rho$  is the coefficient of reflection of the surface,

$\kappa$  is percentage of total sphere effective =  $4\pi - (\phi + \theta)$ .

Now obviously the larger the parabola and the shorter the focal length the smaller is  $\phi$  but care must be taken that in case of small focal length  $\theta$  does not unduly increase, due to lamp socket or support. As a practical matter  $\kappa$  ranges from 0.5 or less in shallow parabolas to 0.8 or even 0.9 in deep ones of focus say of only one-tenth the diameter of the opening.

$\rho$  ranges from perhaps 0.6 with cheap metal reflectors to 0.8 or 0.85 in high grade silvered glass mirrors.

$\sigma$  ranges from 1 to nearly 1.5 in various lamps. A lamp is at its best when its main axis of filament is in the axis of the mirror. Its distribution is then a *tore* (Fig. 2) a doughnut with a very small hole, and the main body of light is well reflected.

Reflectors with depolished surface or fronted with a depolished screen scatter the light from each element of surface and increase the scattered secondary beam at the expense of the primary closely directed beam. They thus may throw light over an angle of  $90^\circ$  or so and cannot give high concentration, although showing very low intrinsic brilliancy and having a distinctly useful place in illumination, for instance of a tennis court.

In practical flood lighting the value of  $\eta$  is likely to run from 0.5 to 0.75, more nearly the former figure when dealing with reflectors and lamps in their average condition. In lamps of the (arc) carefully designed search light type  $\eta$  may rise to or somewhat above unity on account of the large proportion of light delivered from the advantageously placed crater to the mirror and the small proportion of light obstructed by the source.



Fig. 2.—Light tope.

Assuming  $\eta = 0.5$  for an ordinary flood light one reaches the following very simple formulæ for the relation between illumination, energy and circle of illumination.

$$E = \frac{2W}{r^2} \quad (1)$$

$$W = \frac{Er^2}{2} \quad (2)$$

$$r^2 = \frac{2W}{E} \quad (3)$$

Dividing lumens by area gives illumination in lux, if area is in square meters or in foot-candles if in square feet. Hence the following examples.

Required; illumination on a circle of 10 in. radius from a 1000 watt lamp and reflector.

$$E = \frac{2 \times 1000}{100} = 20 \text{ lux}$$

Required, watts to give 50 lux on a circle of 5 meters radius

$$w = \frac{50 \times 25}{2} = 625$$

Required, circle which 4000 watts will light to 20 lux.

$$r^2 = \frac{8000}{20} = 400$$

$$r = 20 \text{ in.}$$

It will be observed that the distance does not enter these reckonings, for the simple reason that so long as *all* the flux of the primary beam falls on the required surface distance does not count save as it may involve atmospheric absorption which is of small moment at flood-lighting distances. Only when the spread of the beam gets it off the object does distance become important in reckoning the illumination. At very short range the secondary beam proceeding directly from the source may not be negligible, and this follows the ordinary inverse square law.

Sufficient has been said already to outline the general method of reckoning exterior illumination. The fundamental principle is to reckon average illumination from the flux theory according to methods which have been already laid down in a previous lecture, and then to make sure of a sufficient amount of uniformity and a sufficiently large minimum by computing the illumination directly from the candle-power curve of the illuminants concerned at any point. In open squares several sources, in small squares all the sources have to be considered. In street work one need very rarely add the illumination from more than two sources on one side of the point of reckoning, the symmetrical sources on the other side being obvious in their effect. The computations involve no special difficulties and are fully taken care of by the general theory once the candle-power distribution curve of the source is known. With reasonable care in the placement of lamps a very good estimate of exterior lighting including street lighting can be made from light flux alone, the ordinary practice of placing and spacing the lamps being sufficient to secure the necessary light distribution.

It should be mentioned in this connection that the N.E.L.A. Committee, which investigated the details of street lighting, found that for practical purposes the useful illumination was pretty nearly

proportional to the light flux as might have been anticipated. In most instances it is the lower hemispherical flux which is concerned. In narrow streets well built up where the limiting walls have a perceptible effect on the distribution of the light one might include the total flux which for lamps with reflectors is roughly proportional to the lower hemispherical flux in any case. Street illuminants therefore can rather fairly be rated in terms of the total lumens which they give, subject to the requirement that reasonable intelligence must be used in locating the sources.

In exterior illumination even more than in interior it is the adaptation of means to ends which makes the difference between good and bad results. One cannot safely travel on a hard and fast theory in such matters. He cannot, for example, say, I will take the *abcd* lamp of (*n*) candle-power as my standard and I will adapt all things to it. If he does so the result is quite certain to be mediocre in quality. It is practically necessary in meeting the great range in intensities required in exterior lighting to depend upon not one kind or size of unit but at least several sizes and perhaps several kinds.

At the present moment for light sources materially below somewhere about 1000 candle-power the large high efficiency incandescent lamps have the call. In larger outputs than this the big luminous and flame arc lamps still hold their own well. A few smaller arc lamp units are used for strictly ornamental lighting, but the carbon arc lamps of every kind and even the smaller flame and luminous arc lamps are rapidly passing to the scrap heap. How far the tendency just indicated can go on, and whether the arc lamp is to have a permanent place in exterior lighting is somewhat open to doubt. My own opinion is that, particularly on account of the conspicuous difference in color, the best of the flaming and luminous arc lamps have at least a considerable period of usefulness still before them, but in the smaller sizes the hand-writing is certainly upon the wall. Ordinary public lighting is generally found as a matter of practice to include the use of at least three sizes of units, two of which will generally be incandescent electric lamps or the equivalent gas mantles.

For the lighting of public squares and first-class streets the big units, whether arc or incandescent, are altogether desirable. For second-class streets one may either retain the same size and type of unit expanding the spacing a bit, or may pass to a smaller unit. The latter is the more common practice, although some transitional streets may be very well treated in the former fashion. The smaller

units may pass into some of the lighting of third-class streets, the distances of spacing being stretched a bit in response to the smaller necessities. It is quite usual, however, to employ a still smaller unit for much of the third-class lighting as well as for all the cases requiring lamps merely as markers. More than three sizes of lamp are very rarely indicated, and extremely good work can be done with two, although the gain in simplicity so attainable does not amount to much.

In shades and glassware one commonly finds that each type of unit has its own requirement. All powerful radiants like arc lamps and very large incandescent lamps should be provided with diffusing globes. These can now be obtained giving good diffusion without much loss of light. Lighting units of more moderate output, say from 100 to 300 candle-power, in many cases require screening to obtain the best results, particularly toward the upper limit of size just mentioned. An incandescent lamp of a couple of hundred candle-power, unshielded, is rather an offense to the eyes, and diffusing glassware or frosted bulbs very much improve the actual lighting effect, although they sometimes create an entirely false impression of insufficient light. Most people still judge a street lamp by its intrinsic brilliancy rather than its actual power, and this psychological fact must be kept in mind. Lamps of smaller output than 100 candle-power seldom need screening, for while they may be unpleasantly bright when viewed from very nearby, in the position, actually occupied by them they may be comparatively inoffensive.

#### COLOR IN LIGHTING

In the lighting of buildings and monuments and flood lighting problems generally, and to a less extent in some types of street lighting, the matter of color may rise to considerable importance. Save in rare instances color in illumination can only be obtained at a considerable and sometimes almost prohibitive cost of energy. One can get very efficiently a bright yellow from the flame arcs, a color perfectly good for utilitarian purposes, but not lending itself to any decorative effects. It is possible to produce flaming electrodes giving striking colors at some loss of efficiency, but yet at an efficiency probably exceeding anything that can be obtained by screens or colored globes. At the Boston Electrical Show of 1912 red and green flame arcs, owing their color only to the impregnation of the electrodes, were used with rather beautiful effect, but such

electrodes cannot be obtained commercially, and the illuminating engineer has to fall back practically upon screens for obtaining colored effects.

Color in lighting may be utilized to intensify the hue of objects already colored or to impart color to things not already possessing it. Light as nearly white as possible brings out the natural color values in a fairly uniform way. A single color gains in brilliancy from flooding with the same color, while illumination with the wrong color may utterly spoil the effect. These things are, of course, perfectly familiar in interior lighting. The decorative value of color has been comparatively little appreciated or utilized in exterior illumination. The most striking instance of its employment on a large scale was at the Panama-Pacific International Exposition of last year, at San Francisco, in which for both day and night effects color played a predominant part. In regular flood lighting work a monument or even a sign may be so tinted as to gain from the application of a particular color in its illumination. But instances where this can be advantageously applied are rather rare.

Perhaps of more general importance is the possibility of producing highly decorative results in the illumination of façades of buildings by giving them color values which relieve the monotony of the effect otherwise attainable. Comparatively little has been done in this line, although the writer tried it out experimentally on the façade of the Massachusetts State House and of the building of the Edison Illuminating Company last year far enough to learn something of its possibilities. The chief difficulty in such work, which can be carried out with very beautiful effects, is to obtain the necessary illumination without too great cost in energy. Screens of the colored film used in theatrical work can readily be arranged in conjunction with lamps for flood lighting. In the case of the experiments just referred to the screens were fitted into frames in racks just in front of the lamps. In theatrical working the areas to be covered are small and the available intensities are so great that a considerable range of color can be successfully employed. This range is much limited in the larger problems of exterior lighting unless at great cost of energy. Light yellow screens fail to produce any striking effect. Even amber tints, although losing considerable light, do not seem to produce a good hue on the surface illuminated. Light reds work better and light rose pinks also are very successful. Greens and blues are not very striking unless deep in color and consequently wasting much light.

In general terms the loss of light in colored screens of hue deep enough to produce any material effect is from 50 to 80 per cent. so that one has to allow from 3 to 4 or 5 times the intensities which would ordinarily be utilized for flood lighting. It is not necessary to fit all the reflectors with screens in doing such work. A ground illumination can be produced in the ordinary way and then tints laid on by banks of special reflectors directed either so as to overlay the whole or any part of it with warm color.

Considerable experimenting is needed to produce screens which will give the maximum of tinting effect with minimum loss of light and which will retain their color without fading. Of course, the films used for theatrical purposes will not withstand moisture so that when used out of doors they must either be screened in with glass or withdrawn in rainy weather. The colored applications are interesting, and probably will be made an important adjunct in flood lighting, but the whole matter is still in the experimental stage.

## MODERN PHOTOMETRY

BY CLAYTON H. SHARP

The present lecture is to be looked upon as in a measure a continuation of the lectures on the measurement of light given in the 1910 I. E. S. course at Johns-Hopkins University. It is intended to supplement those lectures not only by introducing an account of the developments in photometry since 1910, but also by treating of certain matters which were either insufficiently treated or were omitted entirely from the 1910 lectures. It should be understood, however, that it is the intention of the lecturer not to attempt a complete review of photometric advance during recent years, but rather to confine himself to the practical features which properly belong in this essentially practical course.

The practice of to-day in the measurement of light involves innovations and improvements which the change of conditions since 1910 has brought forward. Since 1910 the introduction of the gas-filled tungsten filament incandescent lamp with its whiter light has made the photometric difficulties due to color differences a more important factor in the art and has been a direct incentive toward the prosecution of the investigation of the problem of heterochromatic photometry and of the introduction of means to solve it, while the increasing demand for accuracy in photometric measurements, and particularly the growth of the idea of the measurement of luminous output of all lamps in terms of their total luminous flux rather than in terms of their candle-power, has given a great incentive to the use of the integrating sphere. During the six-year interval new and improved types of apparatus have been constructed and put into use.

### PHYSICAL PHOTOMETER

The physical photometer, an apparatus which will measure the light from any illuminant and give the result in terms identical with those which would be obtained by the use of a photometer by a person of normal color vision, has been realized. This physical photometer has been constructed and practically used by Ives<sup>1</sup> who uses a sensitive thermopile as a means for measuring the radiant energy. He has two methods for selecting the radiation from the



lamp in accordance with the luminosity curve of the average human eye. The first of these methods involves passing the light through a spectroscope equipped with a shield or screen which is cut out in the form of the luminosity curve. The spectrum, which is thereby reduced to a luminosity curve spectrum, is reunited, and the total energy passing through the screen, which is then proportional to the light of the lamp, is thrown on the thermopile. The second method, which for experimental purposes is undoubtedly simpler, involves passing the light through a glass cell having a thickness of one centimeter containing the following solution:

Cupric chloride.....	60.0 grams
Potassium ammonium sulphate.....	14.5 grams
Potassium chromate.....	1.9 grams
Nitric acid, gravity 1.05.....	18.0 c.c.
Water added to make one liter.	

Between the solution and the lamp is interposed another water cell to prevent overheating of the solution. The transmission of this solution is according to Ives identical with the luminosity curve of the average eye.

#### FLICKER PHOTOMETER

Ives<sup>1</sup> has recommended a system of heterochromatic photometry involving the use of a standardized form of flicker photometer and the investigation of the color vision of the observers using it. The flicker photometer as recommended by him has a field two degrees in diameter with a surrounding field of large dimensions illuminated to approximately the same degree. As the standard illumination for the flicker field he recommends 25 meter-candles.

A simple attachment to be used on an ordinary Lummer-Brodhun photometer to convert it to a flicker photometer corresponding to these specifications has been described by Kingsbury<sup>2</sup> and is expected shortly to be commercially available. Ives has shown both theoretically and experimentally that the settings of observers using a flicker photometer are affected by peculiarities of their color vision. He has, therefore, proposed a criterion for normality of color vision of observers using the flicker photometer. This consists in measuring the light of a 4-wpc. carbon lamp through a one centimeter layer of each of two different solutions. The first consists of 72 grams of potassium bichromate in water to make one liter. The trans-

<sup>1</sup> Ives, I. E. S. Transactions, 1915, page 315. A bibliography of the subject is there given.

<sup>2</sup> Kingsbury, Journal of Franklin Institute, August, 1915.

mitted light with this solution is yellowish. The other solution consists of 53 grams of cupric sulphate in water to make one liter. This gives a bluish color. The solutions are to be used at 20°C. Ives has shown that a person with perfectly normal color vision will find with a flicker photometer the same value for a 4-wpc. lamp with either solution. His proposal then is to make color measurements using the flicker photometer and a group of observers so selected that on the average their value for the transmission of the yellow solution is the same as that of the blue solution, such a group having according to his measurements normal color vision. This proposal has been thoroughly investigated by Crittenden and Richtmyer<sup>3</sup> who by studying the peculiarities of a large number of observers using a Lummer-Brodhun photometer have shown that identical photometric results are obtained by a selected small number of observers having on the average normal color vision as determined by Ives' criterion and using a flicker photometer.

#### CROVA'S METHOD

Ives<sup>4</sup> has shown that an incandescent gas mantle can be compared without error with a 4-wpc. carbon lamp using an ordinary photometer and interposing between the eye and the photometer a 25 mm. layer of the first of the following solutions. To effect a comparison between a 4-wpc. carbon lamp and other incandescent electric illuminants the second of the following solutions is used:

	For mantle burners	For incandescent electric lamps
Cupric chloride.....	90 grams	86 grams
Potassium bichromate.....	30 grams	60 grams
Nitric acid (1.05 gravity).....	40 c.c.	40 c.c.
Water added to make one liter.		

When using the first solution with a mantle burner against a 4.85-w.p.scp. carbon standard, the standard has a value which is one divided by 1.065 times its true value. No correction is necessary in using the second solution. The use of this solution has the great advantage of eliminating not only the color difference between the lights as seen in the photometer field, but also the effects of pecu-

<sup>3</sup> Crittenden and Richtmyer, I. E. S. Transactions, vol. 11, page 331, 1916.

<sup>4</sup> Ives, Physical Review, page 716, 1915. Ives and Kingsbury, I. E. S. Transactions, vol. 10, page 716, 1915.

liarities of color vision on the part of the observer. It suffers from the disadvantage, which under many conditions is a very serious one, of cutting down the brightness of the photometer field to about one-tenth the value which it otherwise would have. This necessitates either a rearrangement of the photometric apparatus so that the photometric field shall be much brighter than otherwise is necessary, a procedure which is attended with certain practical difficulties, or requiring the observer to work with a faint field and consequently to keep his eyes shielded from extraneous light so that their photometric sensibility may be sufficiently great.

### LIGHT FILTERS

The difficulties of heterochromatic photometry may be effectually overcome by interposing between the photometer and one of the light sources a colored screen which will cause the illumination on both sides of the photometer disc to have the same color. The use of this expedient presupposes, however, that the amount of light absorbed by such a filter when used with the light in question is known. The determination of the transmission factors of light filters involves all the difficulties of heterochromatic photometry, but relegates them to the domain of the standardizing laboratory, where they can be overcome by the experimental means at hand. The use of light filters, since it reduces the practice of the comparison of lights of different color to the same degree of simplicity as the comparison of lights of the same color, and by means at once convenient and free from liability to error, is becoming very extended and may be rightly described as the most commonly accepted method in practical photometry. These light filters may be of translucent solids or may be in the form of solutions. Ives and Kingsbury<sup>5,6</sup> have investigated yellow and blue solutions for use in this way and have given equations whereby their transmission may be computed. Such solutions may, with suitable precautions be used as reference standards. Mees<sup>7</sup> has produced a line of carefully constructed light filters using colored gelatins, these filters covering the entire range of the ordinary lights to be measured. It is found practicable to get colored glasses serving as light filters for nearly all purposes. For instance a blue glass may be obtained which when interposed between a 4-wpc. standard and a pho-

<sup>5</sup> Ives and Kingsbury, I. E. S. Transactions, Vol. 9, page 795, 1914.

<sup>6</sup> Ives and Kingsbury, I. E. S. Transactions, Vol. 10, page 253, 1915.

<sup>7</sup> Mees, I. E. S. Transactions, Vol. 9, page 990, 1914.

tometer will give a color match with a 1-wpc. tungsten lamp, or a pinkish glass may be found which when interposed between a 1-wpc. tungsten lamp will give a color match with a 4-wpc. carbon standard. Glasses also may be obtained to give a color match of gas-filled tungsten lamps with vacuum tungsten lamps, etc.

As has been said the calibration of these glasses rests with a standardizing laboratory and involves all the difficulties of heterochromatic photometry. Through an extensive set of measurements of certain light filters made by a number of laboratories under the lead of the Bureau of Standards,<sup>8</sup> certain light filters in the possession of the Bureau of Standards have come to have an unusually accurate calibration. It is possible for other laboratories to have standards calibrated by comparison directly with those at the Bureau of Standards or indirectly through other laboratories deriving their standards from the Bureau. Through this procedure light filters of carefully known value may readily be obtained by any photometrist, and by the use of these filters the difficulties of heterochromatic photometry can in nearly all cases be overcome and the same degree of concordance attained in the photometry of different colored lights which is expected in the photometry of lights of the same color.

#### EXTRAPOLATION OF LAMP VALUES

Middlekauff and Skogland<sup>9</sup> have shown that a curve or equation giving the relation between the voltage and current or candle-power of tungsten lamps can be established which holds within close limits for tungsten filament lamps of all ordinary sizes and styles of construction; so that knowing the candle-power of any normal tungsten lamp by calibration at a voltage at which its color matches the color of the standard, its candle-power at some other voltage at which it gives a color corresponding to the lamp under test may be accurately computed. This method, which has the endorsement of the U. S. Bureau of Standards, should be of great practical utility.

#### STANDARD LAMPS

Since 1910 the drawn wire tungsten lamp has supplanted the pressed filament lamp, and lamps of drawn wire are now used for purposes of photometric standards. In the smaller sizes of lamps

<sup>8</sup> Middlekauff and Skogland, I. E. S. Transactions, Vol. 9, page 734; also Bulletin of Bureau of Standards, Vol. 3, p. 287.

<sup>9</sup> Middlekauff and Skogland, I. E. S. Transactions, Vol. 11, page 164; also Bulletin of Bureau of Standards, Vol. 11, p. 483.

small variations in candle-power are likely to be discovered due to the variations in contact between the filament and the wire supports. It is therefore necessary that, for the smaller sizes at least, lamps should be of special construction, avoiding this variation in contact with its consequent variable loss of heat to the anchor wires. Either the anchor wires are pinched tightly over the filament or the filament is drawn so tightly over the wires that no variability can ensue. The constancy of the candle-power of the drawn wire lamps, together with their mechanical strength, etc., is such as to fit them eminently well for service as standards. They may be standardized not only at a voltage approximating their operating voltage, but also at lower voltages; for instance at such a voltage that they give a color match with a 4-wpc. carbon standard. It is a question whether all things considered, the tungsten standards are not more reliable than the old carbon standards, but the time has not yet come when this question can be finally answered. It is to be noted, however, that inasmuch as the incandescent lamps most used to-day are of the tungsten class, the use of tungsten standards enables photometric measurements to be made without the difficulties of heterochromatic photometry. A photometric laboratory may carry side by side a series of 4-wpc. carbon standards and a series of approximately 1.2-wpc. tungsten standards, each set of standards to be used with its corresponding class of lamps. The introduction of the gas-filled lamp, however, has given rise to a situation where heterochromatic photometry is difficult to avoid. The filaments of these lamps are made up in the form of fine spirals. The candle-power of a spiral wound filament can vary not only because of alteration in its physical state or in the conditions surrounding it in the bulb (convection currents, etc.) but also on account of any change in the spacing of the spires of the helices in which the filament is formed. If on account of sagging at the high temperature at which the filaments are operated, the little spirals open up somewhat at any point, the candle-power will be found to be reduced at this point, since there the convection currents carry off more heat. Moreover, the question of the conduction of the heat from the filament by the anchor wires is one which may intervene to cause variable candle-power. Hence it is that it is a more difficult thing to get from gas-filled lamps the entire constancy of candle-power at given voltage or current which is demanded of a real standard. Lamps of this type are sometimes calibrated as "check lamps," intended to be used as standards in the industrial photometry of gas-filled lamps, but

not dignified with the name of standards. It is to be hoped that methods of construction will be found whereby entire constancy may be insured in the candle-power of gas-filled lamps specially designed for use as standards. Until this is done the real standards against which gas-filled lamps have to be compared are vacuum tungsten lamps and this comparison involves color differences which, however, can be removed by the use of suitable light filters.

#### 10-C.P. HARCOURT LAMP

This important primary standard has been subjected to thorough investigation at the Bureau of Standards and there has been found a well-defined difference between the pentane lamps of English and American manufacture. Moreover, the newer American lamps are differentiated from the older ones by certain operating requirements. For instance, the time required for the lamp to reach its full candle-power is less than 15 minutes in the case of the English lamp, whereas 20 minutes must be allowed with the newer American lamps and 30 minutes with the older ones. The Bureau authorities have found that the control of the density of the pentane is of considerable importance and that to empty the saturator once a month, as should be done according to the instructions of the London Gas Referees, is quite insufficient when the lamp is used as much as three times a day, since the density of the residual pentane would be considerably greater and its candle-power greater. At the Bureau of Standards the density of the pentane used is always kept below 0.635. The saturator should be from one-third to two-thirds full of pentane at starting, and the height of liquid as seen against the window of the saturator should never be less than  $\frac{1}{8}$  inch. It is recommended that in the photometer room a hood or chimney should be arranged in the ceiling above the lamp in such a way as to carry the products of combustion directly out of the room. The correction for water vapor is made in accordance with the following:

$$I = I_8[l + (8 - l)0.00567].$$

Where  $I_8$  represents the candle-power of the lamp with normal water vapor content, namely, 8 liters of water per cubic meter of dry air, and  $l$  represents the actual humidity. In order to determine the value  $l$  a hygrometer of the wet and dry bulb type is used. The most precise instrument is the Assmann psychrometer which consists of two finely divided mercury thermometers, mounted side by side on a stand and with a tube surrounding the bulb of each.

At the top is a small spring-driven suction pump which draws a rapid current of air over both bulbs. One bulb is surrounded by a cloth which is wet with water, while the other is dry. From the difference between the readings of the two, by reference to hygrometric tables, such as for instance the tables issued by the United States Weather Bureau, the pressure of the water vapor is determined. A simpler apparatus than the Assmann psychrometer is the sling psychrometer, used extensively by the Weather Bureau. This is a relatively inexpensive apparatus consisting of two thermometers mounted on a handle so that they can be swung rapidly in a circle. One of them being wet and the other dry, a difference is obtained which corresponds to the humidity of the atmosphere. Knowing  $e$ , the partial pressure of the water vapor, and the barometric height,  $b$ , in millimeters, the water vapor in liters per cubic meter of dry air is found from the equation

$$l = \frac{e}{b - e} \times 1000$$

The effect of variation in atmospheric pressure on the candle-power of flame standards has been investigated by Butterfield, Haldane and Trotter in London and also by Ott<sup>10</sup> in Zurich. Ott confirmed the old formula of Liebenthal, as follows:

$$I = 1.049 - 0.0055l + 0.00011(b - 760)$$

Butterfield, Haldane and Trotter found a relation which is depicted in curves of Fig. 1.

A late investigation by the U. S. Bureau of Standards<sup>11</sup> yielded the curves of Fig. 2.

The variation of standard flames with barometric pressure is of vital importance when dealing with these standards in places located at considerable altitudes above sea level, and affects us particularly in this country where there are a number of important cities at relatively high altitudes.

#### PORTABLE ELECTRIC STANDARD

A portable electric standard lamp outfit which has been used to a limited extent in gas photometry is illustrated in Fig. 3. The lamp used has a single loop tungsten filament and is of such a rating that when burned so as to give two candle-power, it has a color which

<sup>10</sup> Ott, Journal of Gas Lighting, Nov. 16, 1915.

<sup>11</sup> Transactions I. E. S., Vol. X, page 843, 1915.

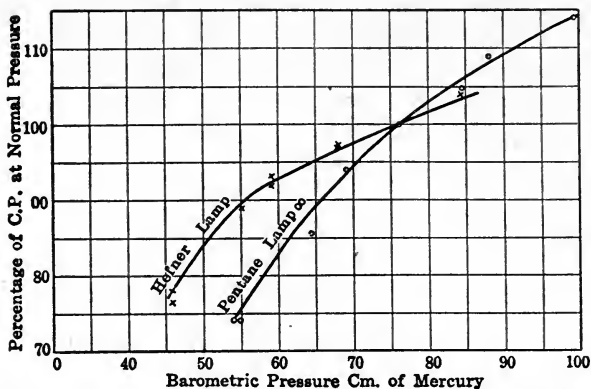

Fig. 1.—Variations of flame candle-power with atmospheric pressure. (Butterfield, Haldane and Trotter.)

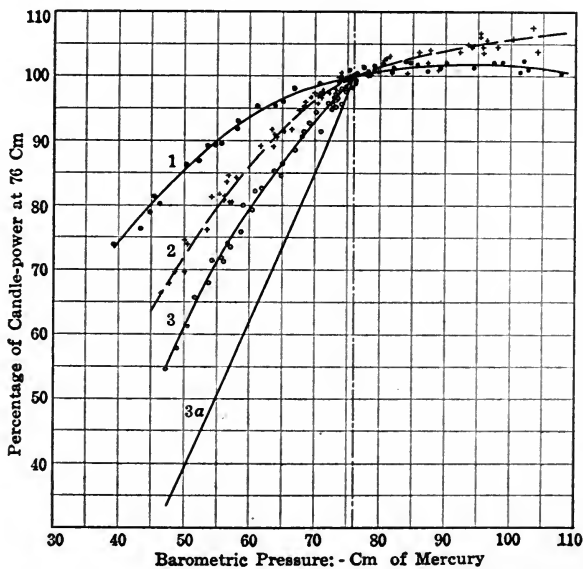

Fig. 2.—Variations of flame candle-power with atmospheric pressure. (1) Hefner lamp; (2) Pentane lamp; (3) No. 7 Bray slit union gas burner. (Bureau of Standards.)



matches that of gas burned in an open burner. It then consumes approximately one ampere with four volts potential difference between its terminals. The current for the lamp is furnished by a portable six-volt storage battery such as is used frequently for gas-engine ignition purposes and of 40 ampere-hour rating. The battery, therefore, when fully charged is capable of supplying current to the lamp for a considerable time. On the controller box are mounted suitable rheostats and also a

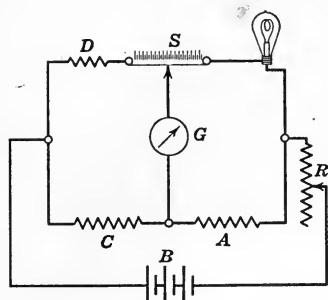

Fig. 7.—Diagram of bridge of portable standard.

Wheatstone bridge and galvanometer for setting the lamp to its standard candle-power. As is well known, the tungsten filament has a large positive temperature-resistance coefficient. If the lamp, therefore, is made one arm of a Wheatstone bridge, the other arms being constituted of zero temperature coefficient wire, as shown in Fig. 7, the resistances may be so adjusted that the bridge is in balance when the lamp is operating at its normal candle-power. As soon as the current through the lamp varies, its resistance also varies and the bridge falls out of balance. The balance of the bridge is indicated by a pivoted galvanometer which is shown in the figure, or it may be determined by means of a telephone and an interrupter which gives a slight click in the telephone if the bridge is out of balance. This method of adjusting the standard lamp is a very sensitive one, particularly when a galvanometer is used; far more sensitive than a direct reading ammeter or voltmeter, even of the laboratory standard type. In order to permit adjustment, there is a portion of the bridge in the form of a slide wire, the galvanometer circuit making contact with this slide wire at any position desired. The position may be recorded from a divided scale with which the slide wire is equipped.

The apparatus was given the form here described in order that an unskilled man unfamiliar with electrical apparatus should be able to operate the standard. He has merely to close the switch and adjust the rheostat until the galvanometer comes to zero. It should be noted, however, that in a general case a test of candle-power of gas will agree with a test made against a 10-c.p. pentane lamp only when the conditions of atmospheric humidity are standard for the lamp, that is, eight liters of water per cubic meter of dry air.

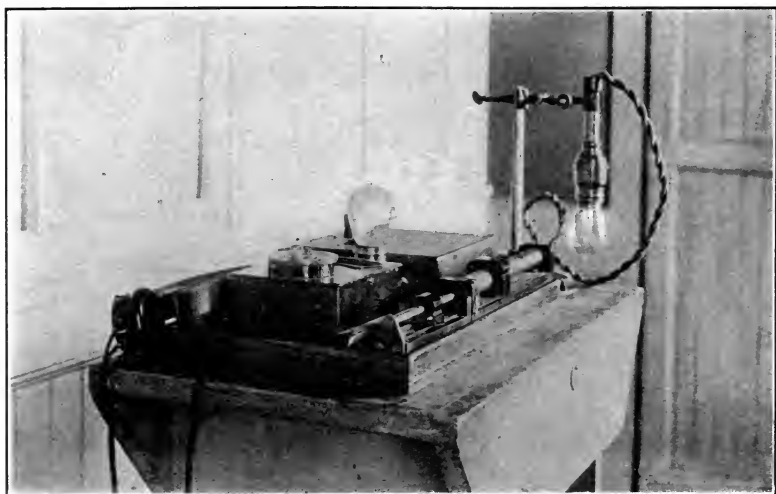

Fig. 3.—Portable electric standard.

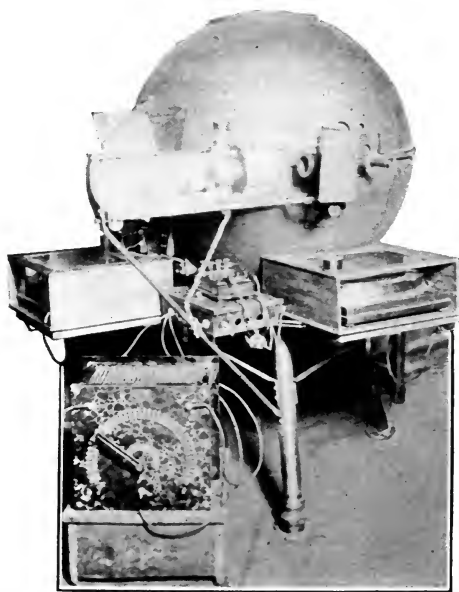

Fig. 4.—One-meter sphere for industrial photometry of incandescent lamps.

*(Facing page 107.)*

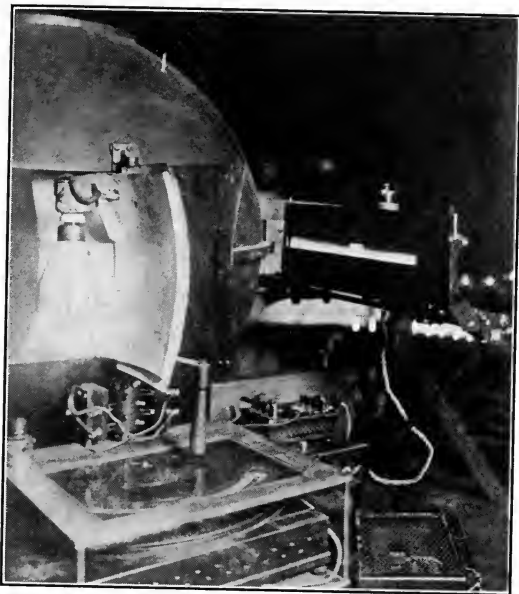

Fig. 5.—Industrial sphere photometer, showing arrangement of sphere doors and photometer scale.

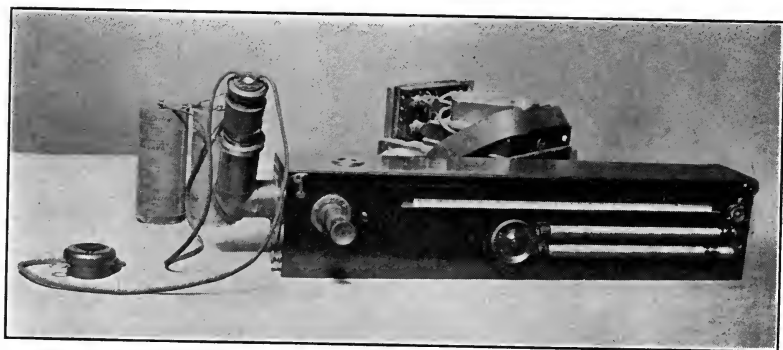

FIG. 6.—Sharp-Millar calibrator in position on photometer.

If the hygrometric condition is different from this a different result will be obtained. It is, therefore, necessary in using the electric standard to observe with, for example, a sling psychrometer the hygrometric condition, and to apply a correction to the invariable electric standard to make it agree with what the pentane standard would show under similar conditions. The operation involved in this correction can be reduced to great simplicity.<sup>12</sup>

*Total Flux Standards.*—Standards of flux or of mean spherical candle-power have to be derived from ordinary standards of candle-power. In the primary standardization of lamps in lumens, therefore, it is necessary to adopt some method whereby the total luminous flux can be computed from a series of candle-power measurements in a sufficient number of directions. In the practice of the Electrical Testing Laboratories in making lumen standards, the lamp is first standardized carefully as an ordinary standard for mean horizontal candle-power. Then its candle-power distribution curve is determined by measurements at various angles in the vertical plane and the lamp's spherical reduction factor, or the relation between its spherical candle-power and its horizontal candle-power is computed. The known horizontal candle-power multiplied by the spherical reduction factor gives then the spherical candle-power. The latter multiplied by  $4\pi$  gives the total lumens. Having established standards by this procedure, copies sufficiently accurate for industrial purposes can be made by the more direct method of the integrating sphere.

#### BAR PHOTOMETER

The bar photometer, the classic apparatus of the photometrist, is being used more and more according to methods which were but little recognized a few years ago. The standard method in the use of the bar photometer was for many years to fix the light sources at the ends of the bar and to move the photometer between them until the point of balance was obtained. It is becoming now more common practice to allow the photometer head to remain stationary and at a fixed distance from the light source to be photometered; that is, the test lamp, while the photometric balance is effected by moving the comparison lamp. This method of using the bar is an almost necessary one in the photometry of large sources of light, particularly of lamps with reflectors having concentrating properties, in the photometry of projectors, etc., where it is important to measure the

<sup>12</sup> Sharp and Schaaf, *American Gas Light Journal*, Vol. VIII, p. 325, 1913.

apparent candle-power of a source at a fixed distance. It has been found feasible and desirable from the point of view of convenience, to diminish the length of the bar and this has been made by the use of small low voltage tungsten filament lamps for comparison lamps. A low voltage tungsten lamp has a filament so small that it can be considered as a point source of light when very much closer to the photometer disc than is possible with the ordinary lamp. On this account the comparison lamp can be brought up much closer to the disc and the whole bar very greatly shortened without any practical decrease in accuracy of the apparatus. In doing this the bar photometer approaches the construction which is well known in the case of portable photometers intended primarily for the measurement of illumination; in fact it is found that in a great deal of practical work a portable photometer may be substituted for much more elaborate and cumbersome photometer bars. In precision work it is desirable that the brightness of the disc shall have a known and constant value. In order to attain this condition the comparison lamp is fastened to the carriage on which the photometer head is mounted and the distance of the two from the test lamp is varied in order to get the photometric balance. In this case again the use of the small tungsten lamp as a comparison lamp enables a simplification to be made in that the lamp can be mounted on a short arm which is rigidly attached to the photometer carriage, thereby avoiding the necessity of an additional carriage.

#### INTEGRATING SPHERE

The use of the integrating sphere is extending very rapidly. The Committee on Nomenclature and Standards of the Illuminating Engineering Society has made recommendations as follows:

Illuminants should be rated upon a lumen basis instead of a candle-power basis.

The specific output of electric lamps should be stated in terms of lumens per watt and the specific output of illuminants depending upon combustion should be stated in lumens per British thermal unit per hour.

When auxiliary devices are necessarily employed in circuit with a lamp, the input should be taken to include both that in the lamp and that in the auxiliary devices. For example, the watts lost in the ballast resistance of an arc lamp are properly chargeable to the lamp.

The specific consumption of an electric lamp is its watt consumption per lumen. "Watts per candle" is a term used commercially in connection with electric incandescent lamps, and denotes watts per mean horizontal candle.

These recommendations have been adopted by the American Institute of Electrical Engineers and by the National Electric Light Association. The measurement of the horizontal candle-power of gas-filled lamps has, for reasons which are discussed later, been found unsatisfactory. All of these facts tend to bring the integrating sphere into a position of greater importance in practical photometry. Little has been added to the theory of the integrating sphere or to the principles of its practice since Ulbricht's treatment of the same, but there has been a considerable development of the sphere in the way of making it a more practical apparatus for routine photometric work. Inasmuch as the theory of the sphere was merely hinted at in the 1910 lectures, it may be well here to say more about it.

It has been shown that a diffusing glass window on the surface of the sphere is illuminated by each element of surface of the sphere to a degree dependent only on the brightness of that element and independent of its position. This presupposes that the direct light of the lamp in the sphere is not allowed to shine on the window. No other form of enclosure, such as a box, conforms to this theoretical law and hence all other forms are imperfect integrators as compared with the sphere.

To prevent the direct light of the lamp from falling on to the window a white diffusing screen is interposed. The presence of the screen is a disturbing factor in the sphere for two reasons. First, the light from the lamp falling directly on the screen must be reflected from the latter before it can reach the sphere and hence this part of the flux is diminished by the absorption of the screen before it comes to the sphere surface from which it is reflected to the window. Second, a portion of the sphere surface is hidden from the window by the screen, and the light falling on this portion must be reflected before it reaches a part of the sphere which is reflecting directly on the window. Hence this portion of the total flux suffers a diminution due to the absorption of the sphere coating. As a partial compensation for these two losses we have the light from the sphere reflected by the side of the screen turned toward the window.

It is not difficult to calculate the flux falling directly on the screen and the flux on the hidden part of the sphere. The position of the lamp and of the screen should be such as to make the sum of these two elements of flux a minimum. As a practical matter the amount of this re-reflected flux depends on the distribution of flux from the lamp and hence the position of the screen most favorable for one

lamp would not be best for another. In the case of incandescent lamps in general the best position of the window is at the top of the sphere with the lamp vertical on the vertical diameter, for in this position the lamp base which casts a shadow anyhow, casts it on the screen and so the flux on the screen is less than it would be in any other position. This arrangement is inconvenient and should be resorted to only when the highest precision is desired. In any case the screen error can be made a very small one by using a sphere of adequate size. Increase in the size of the sphere reduces the error

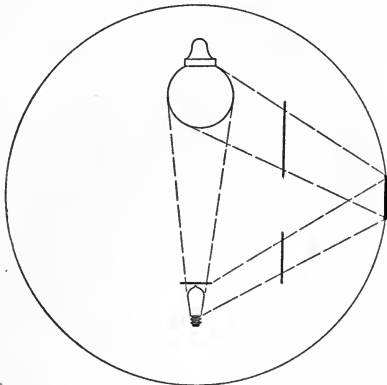

Fig. 8.—Integrating sphere with large lamp and screen.

in two ways; first, by reducing the relative area of the screen as compared with that of the sphere, and second by permitting the screen to be placed further from the lamp whereby the flux on it is decreased. If the lamp is not too near to the wall of the sphere and to the screen and the sphere is of sufficient size, no danger of an excessive screen error is to be apprehended. In any case the use of the substitution method when lamps of more

or less similar candle-power distribution characteristics are being photometered, ensures the partial or complete elimination of the error.

When bulky lamps, such as arc lamps, or lamps with shades or reflectors, are to be photometered, the sphere must be standardized or its constant determined with the test lamp in place in the sphere. This requires that the test lamp and the standard lamp have separate locations in the sphere. The standard lamp should be left in place in the sphere while the test lamp is being measured. There must be a screen between the standard lamp and the window and another between the test lamp and the window. There should also be a screen protecting the test lamp and its parts from the direct light of the standard lamp. A scheme of the arrangement is shown in Fig. 8. The reason for the latter screen is as follows: The test lamp emits a certain flux of light. The parts of the lamp, which are foreign bodies or obstacles in the sphere, interrupt and absorb a certain fraction of this flux, which, therefore, never escapes from the confines

of the lamp as useful light, and should not be measured. The lamp parts, however, interrupt a portion of the reflected flux in the sphere which otherwise would increase the brightness of the window and thus needs to be accounted for. If the direct light of the standard lamp is screened off, the parts or appurtenances of the test lamp will absorb approximately the same fraction of the reflected light of the standard lamp as that of the test lamp, and no great error is incurred.

To determine the effect of the added screen between the standard lamp and the test lamp, a photometer setting is made with the sphere containing only the standard lamp with, and again without, the screen; in other words the total flux of the lamp with the screen is measured against itself without the screen as standard.

The improvements in the integrating sphere have been in the direction of providing for easy and quick introduction and removal of lamps and in the adaptation of the sphere to the photometering of gas lamps. Speaking of the latter point first, it has been found that with a sphere of ample size, from 2.0, to 2.5 meters in diameter, provided with suitable ventilating openings at the top and bottom, gas lamps, even of very large size, can be photometered without difficulty. The ventilating openings need to be made so as to rob the sphere of as little of its white interior surface as possible, and at the same time to prevent the escape of light from the interior and the ingress of light from the exterior. This is quite simply done by covering the opening with a circular disc set down a short distance from the surface, so as to leave a sufficient passage for the air, while cutting off the light.

To facilitate the handling of incandescent lamps, a number of plans have been employed. One quick handling device for the sphere intended for the photometering incandescent lamps was treated of in the 1910 lectures. A device has been used at the U. S. Bureau of Standards and at the Physical Laboratory of the National Lamp Works of the General Electric Company, whereby the act of opening the door of the sphere swings an arm carrying a lamp socket out to the opening so that lamps are readily changed. When the door is closed this arm swings back again and places the lamp at the center of the sphere. A complete sphere photometer has been designed and constructed at the Electrical Testing Laboratories which seems to meet the requirements of routine photometry of incandescent lamps of all sizes. Inasmuch as no other device of this kind seems to have been described in the literature, a fairly complete description may be



given here (Figs. 4 and 5). The sphere is of one meter diameter and has been variously constructed of sheet metal, of cast aluminum and cast iron. The cast aluminum is the most desirable material, but the price of it at the present time is almost prohibitive. The cast sphere is mounted on three legs of two-inch iron pipe with floor flanges, and all of the auxiliary parts are screwed or bolted to the sphere itself which, therefore, forms the carcass or frame of the instrument. Referring to Fig. 5 an opening about 40 by 58 centimeters is cut out of the sphere and two doors, either of which will fit this opening, are mounted on a vertical shaft. To each of these doors is fastened a bracket carrying a lamp socket. Thus when the opening of the sphere is filled by one of the doors, the lamp socket attached to it is in the sphere carrying the lamp to be photometered, while the other lamp socket is outside the sphere ready to have its lamp inserted. When the photometering of the lamp in the sphere is completed, the vertical shaft is rotated a half turn, whereby the already photometered lamp is withdrawn from the sphere and the one to be photometered is put inside. By means of a special switch attached to the vertical shaft the lamp inside the sphere is automatically connected to the source of current. Thus while the lamp in the sphere is being photometered, the lamp which has been photometered can be removed and a fresh one substituted for it. Very heavy filament lamps require the current to be flowing through them for a little time until they reach their ultimate temperature, and consequently their ultimate candle-power. For instance, gas-filled lamps of 20 amperes rating should be photometered after they have been heating for at least one minute. With the sphere here described an auxiliary preheating circuit can be attached so that the lamp which is outside the sphere is being heated during part of the time when the lamp inside the sphere is being photometered.

The photometric arrangements are made part of the sphere itself. The photometer bar which is supported by a cast-iron bracket permits the travel of the comparison lamp over a distance of 46.3 centimeters. The comparison lamp is a low voltage tungsten lamp so selected that it will have the requisite candle-power when it is operating at an efficiency which will cause it to match in color the regular vacuum tungsten filament lamps. There are four scales to the photometer, giving the three following ranges: 30 to 240 lumens, 200 to 1600 lumens and 1200 to 9600 lumens. These scales are directly above each other and are made by contact printing on a photographic plate. The scales are translucent and are read by the

photometer operator who changes the lamp and who sees the shadow of a stretched wire on the scale thrown by the test lamp itself. The photometer operator who makes the settings is ignorant of the scale readings and is thereby protected from any possible bias. Only one scale is visible at a time, the rest being covered by a movable shutter. In order to enable the sphere to be used without change of calibration of the standard lamp, the following arrangement is employed.

Over the diffusing window of the sphere, which has a diameter of 8 centimeters, is placed a hemisphere of the same diameter. This hemisphere contains in turn a small diffusing window which constitutes one side of the photometer disc. In a narrow slot between the hemisphere and the diffusing window of the large sphere is placed a slide with four openings. The largest of the openings has the same diameter as the hemisphere. The next opening has such a diameter that when it is introduced, the brightness of the window of the small hemisphere is cut down to such a degree that the photometer is direct reading on the second of its scales rather than on its first. Inasmuch as the first scale reads from 30 lumens to 240 lumens and the second scale from 200 lumens to 1600 lumens, the amount of brightness reduction on interposing the second opening is in the ratio of 20 to 3. The first scale enables vacuum tungsten lamps of the smaller sizes ( $7\frac{1}{2}$  to 25 watt) to be photometered. For larger lamps it is necessary to go to the second scale which covers the range approximately of 25 watts to 200 watts. Hence by the use of these two ranges all of the ordinary sizes of vacuum tungsten lamps are covered. The other two apertures are intended for the photometry of gas-filled lamps where the whiter color of the lamp introduces an additional photometric difficulty. To reduce this color to the color of the comparison lamp, filters of pinkish glass are placed in apertures 3 and 4. These apertures again are so dimensioned that the photometer is direct reading without readjustment of the comparison lamp. The scale used with aperture 3 is identical with the scale used with aperture 2. The scale used with aperture 4 has a range of 1200 lumens to 9600 lumens and covers therefore gas-filled lamps up to 500 watts. For still larger lamps an additional diaphragm is placed in aperture 4 and the range thereby extended to take in 1000-watt gas-filled lamps. Hence with one and the same setting of the comparison lamps any ordinary incandescent lamp may be read directly. The slide containing the apertures 1, 2, 3 and 4 is mechanically connected to the shutter over the scales, so that when the

slide is moved, the shutter is also moved to expose the proper scale.

Photometric measurements are made by the aid of a Lummer-Brodhun prism. The comparison lamp is held at its standard value by means of a Wheatstone bridge arrangement. Such is described above under the Portable Electric Standard. With this apparatus it is found that incandescent lamps can be photometered more rapidly than on a photometer bar with a rotator.

#### APPLICATION TO THE PHOTOMETERING OF STREET LAMPS

The sphere has also been used in practice in the determination of the candle-power of street lamps. The photometering of lamps in the street by ordinary methods is admittedly unsatisfactory. However, by the use of the arrangement which is referred to in the first lecture on Street Lighting, where a 1 meter sphere is mounted on a truck and brought directly underneath the lamp which is then lowered into the sphere, this class of measurement is made practically as accurate as an indoor measurement.

#### INSTRUMENTS FOR MEASUREMENT OF ILLUMINATION

In addition to the instruments described in the 1910 lectures certain new ones have entered the field and will here be described.

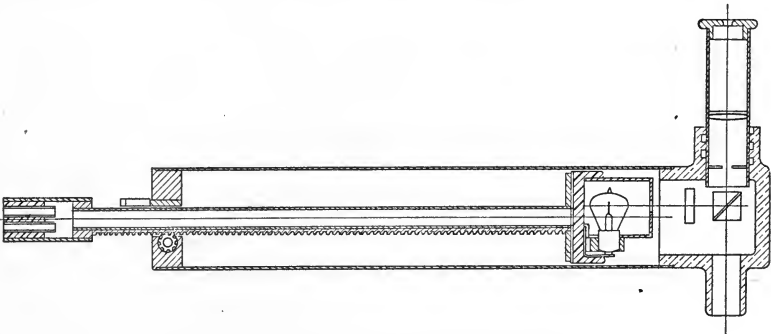

Fig. 9.—Sectional view of Macbeth illuminator.

*Macbeth Illuminometer.*—This is a small, light weight instrument differing only in details of construction but not in principle from other well-known instruments. As shown in Fig. 9 the photometric device is a Lummer-Brodhun cube which is looked at through a lens. A lamp is carried on a rod projecting from the end of the tube and can be moved back and forth by means of a rack and pinion. The

scale is drawn on the exposed portion of this rod. The light from the lamp falls on a small translucent screen which is seen on one side of the field. The other side of the field is a reflecting test-plate located at the point where the illumination is to be measured. The calibration of the scale is in accordance with the inverse square law, the theoretical law of the instrument. A small housing about the lamp provides for the exclusion of stray light from the sides of the tube. The lamp is held at standard condition by means of an ammeter which is contained in a separate box which also carries the necessary rheostats. With

this instrument is provided a so-called reference standard which is shown in cross-section in Fig. 10. This reference standard is arranged to be placed on the reflecting test-plate, and the tube surrounding the sighting aperture is inserted at *D* so that this test-plate may be viewed under the light of the small standardized lamp contained in the reference standard. When a given current is passed through the standard lamp, known illumination is produced on the test-plate, and against this known illumination the photometer can be standardized. It is to be noted, however, that any error of the ammeter is involved

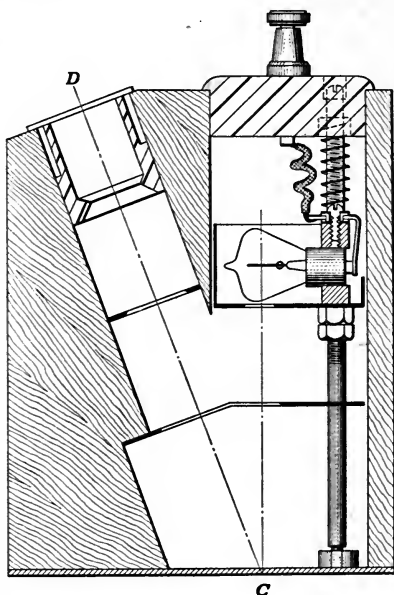

Fig. 10.—Section view of Macbeth reference standard.

in the use of the reference standard and hence the necessity for maintaining the ammeter in correct calibration. The range of the Macbeth illuminometer is normally from 1 to 25 foot-candles. It is increased by the insertion of neutral glass screens on either one side or the other of the Lummer-Brodhun cube. The total range of the instrument with the two screens ordinarily provided with it is said to be from about 0.02 to 1200 foot-candles.

*Sharp-Millar Photometer—Small Model.*—In this smaller model of the photometer described in the 1910 lectures (see Fig. 11), the size has been reduced to approximately  $12\frac{1}{2}$  inches in length and  $2\frac{1}{2}$

by  $2\frac{1}{8}$  inches in cross-section. The box is of metal rather than of wood and the scale which is used has also been reduced to one-half. Like the previous instrument, this is adapted to the measurement of illumination, candle-power and surface brightness. Instead of using an ammeter or a voltmeter for holding the comparison lamp at its proper candle-power, a Wheatstone bridge arrangement such as is described above under the portable electric standard is used. Instead of a galvanometer with the bridge, a telephone receiver is used as a detecting instrument. If the bridge is out of balance, making and breaking the circuit through the telephone gives a series of audible clicks. When the current is reduced to zero, as is

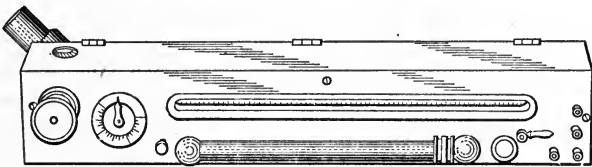

Fig. 11.—Sharp-Millar photometer, small model.

indicated by a state of silence in the telephone, the proper current is flowing through the comparison lamp. The telephone method, while not so sensitive as the galvanometer method, yet is sufficiently sensitive so that a careful observer can set the current to its correct value within closer limits than is possible with a small portable ammeter or voltmeter. The use of the bridge and telephone enhances the portability of the instrument very greatly inasmuch as no other auxiliary apparatus is required than two dry cells or a small storage cell for the purpose of furnishing the current. The instrument is provided with the usual absorbing screens for extending its range and can easily be held in the hand when used. Either an attached transmitting test-plate or a detached reflecting test-plate may be used.

*Calibrator.*—For use with the above instrument and also with the ordinary model of the Sharp-Millar photometer, a calibrator has been devised whereby the accuracy of the calibration of the instrument may be checked at one point. This consists of a short tube (Fig. 6) to be set on the test-plate of the photometer. This tube carries near its upper end a seasoned incandescent lamp which is put in a bridge connection similar to that described above. The bridge is non-adjustable. In connection with the tube is also a rheostat so that the current through the lamp may be varied until the bridge is

in balance. When the bridge is balanced the lamp throws a known illumination on the test-plate and the photometer may be adjusted to give the corresponding reading on its scale. Inasmuch as the scale is known to be correct throughout its length, a check at one point insures its accuracy at all points.

*Compensated Test-plates.*—All illumination photometers measure illumination on the assumption that the light reflected or trans-

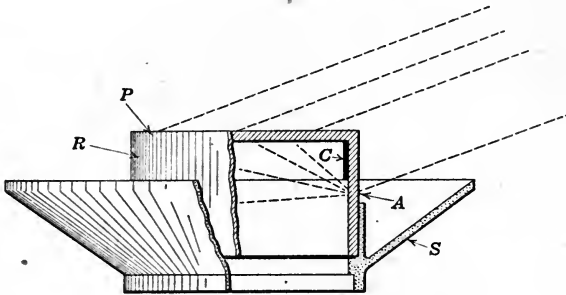

Fig. 12.—Principle of compensated test-plate.

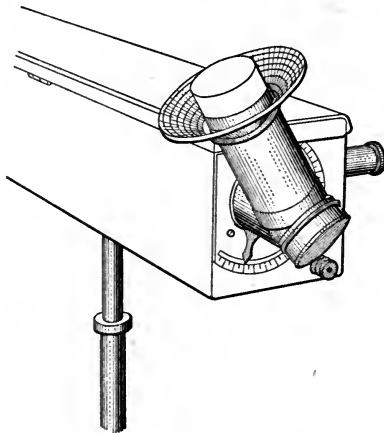

Fig. 13.—Compensated test-plate on a photometer.

mitted from the test-plate follows Lambert's cosine law. As a matter of fact no substance yet found will diffuse light in exact accordance with this law. The light received at high angles produces a brightness of the test-plate which is too small as compared with the similar flux of light incident at small angles. The failure of the test-plate to conform to this law is therefore reflected in an error of the photometer which differs according to the conditions

under which the photometer is used. In an attempt to obviate this error, a so-called compensated test-plate as illustrated in Fig. 12 has been produced.<sup>13</sup> In this figure the light incident upon the upper surface of the test-plate *P* is reinforced by light admitted through a translucent glass ring *A*, so that at all angles the brightness of the under surface of *P* due to the combined action of the light trans-

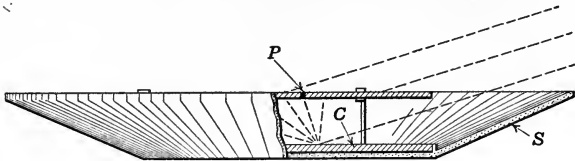

Fig. 14.—Principle of compensated reflecting test-plate.

mitted from above and the light incident upon it from beneath, corresponds to the theoretical amount. It will be noted that the amount of compensation increases with the angle of incidence and hence can be made practically complete for all angles up to the very

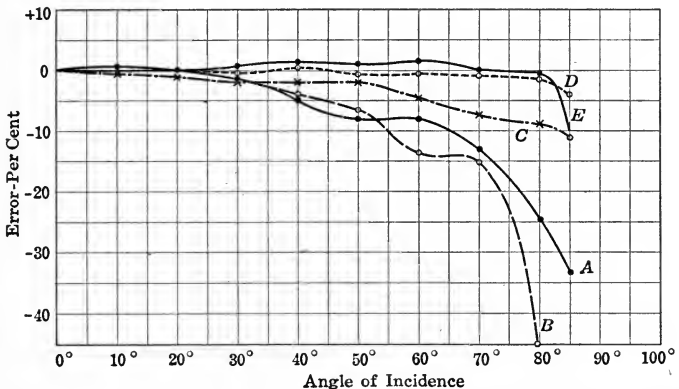

Fig. 15.—Errors of various test-plates viewed normally. A, Depolished transmitting plate; B, polished transmitting plate; C, depolished glass reflecting plate; D, compensated transmitting plate; E, compensated transmitting plate.

high ones. The intrusion of light to the ring *A* when the rays are parallel to *P* is prevented by the screen *S*. The test-plate is attached to a photometer as shown in Fig. 13. The same principle is shown applied to a reflecting test-plate in Fig. 14. In this case the reflecting test-plate consists of a sheet of depolished white glass. This is set a small distance from another diffusing white surface *C*. Compensating light falling upon the plate *C* is reflected on the lower sur-

<sup>13</sup> Sharp and Little, I. E. S. Trans., Vol. 10, p. 727, 1915.

face of  $P$ , transmitted to the upper surface of  $P$ , and reinforces the light reflected from  $P$  to exactly the right amount to insure compensation for the deficiencies of  $P$  at high angles. The behavior of various test plates is summed up in the curves of Fig. 15. It is evident that where high precision is required in illumination photometry, and where test-plate errors cannot be computed and allowed for, the use of some form of corrective test-plate is of vital importance.

*Static Illumination Tester.*<sup>14</sup>—This instrument provides a means for the ready measurement of illumination to a relatively low degree of

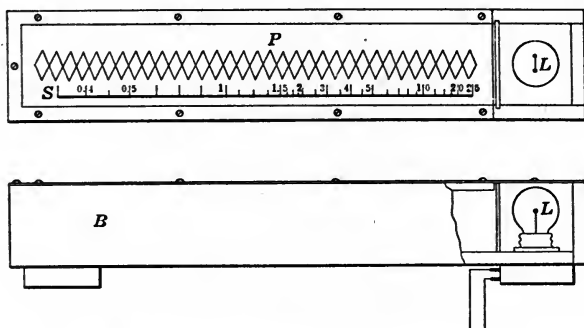

Fig. 16.—Principle of simplified illumination tester.

precision by an instrument of extreme simplicity in construction and use. The principle which it involves may be described as follows: The field of uniformly graded brightness produced by the comparison lamp, instead of being formed in the air where it is invisible, is formed on a sheet of diffusing material, which thereby is given a continuously graded brightness. The light which is to be measured falls on a diffusing sheet in juxtaposition to this field, so that the point can be readily seen where the brightness of the one field equals that of the other. The graded field being calibrated, the brightness of the unknown field is determined by finding with the eye the point where the brightness of the unknown field equals the brightness of the known graded field.

The illumination tester embodying this principle is shown in Fig. 16. This figure shows a rectangular box  $B$  approximately  $2.5 \times 2.5$  cm. in cross-section by 20 cm. long, containing at one end a small tungsten filament lamp  $L$  behind an opal glass screen. The top of the box over the rest of its length is made up of a sheet of

<sup>14</sup> Sharp, *Electrical World*, September 16, 1916.



clear glass to which is pasted an arrangement of papers *P* which constitutes what may be described as a continuous photometer disc of the Leeson type, extending from one end of the glass to the other. The interior of the box is painted white, except for the far distant end which is black. The photometric element *P* consists of a sheet of fairly heavy paper with a slit cut out of it having saw tooth edges. Over the entire arrangement is then pasted a sheet of thinner translucent paper having a mat surface. When the lamp is lighted, the end of the slit nearest the opal glass is seen to be very bright, and this brightness fades away gradually toward the other end of the slit. When an exterior illumination falls on this photometric device, the outer portions are illuminated almost wholly by this exterior illumination, while the slit is illuminated chiefly by the light from the inside of the box. At the point where the brightness of the exterior portion is the same as the brightness of the slit, the saw teeth fade away and are hard to distinguish. This point which can be recognized without difficulty provided the papers are properly selected for the purpose, indicates the photometric value on the scale.

The completed apparatus in its experimental form is shown in Fig. 17. In this figure the photometric box is seen mounted on a larger box which contains a single dry cell serving as the source of current. The box also carries a small precision voltmeter and a rheostat. The photometric box is so arranged that it can be removed from the rest of the apparatus, the flexible cord conductor with which it is connected being stowed away in the larger box when the two are used as a unit. Photometric readings are taken in a direction at right angles to the axis of the box. The exact angle to the vertical at which these readings are made seems to be of relatively little importance in the general case.

By slight structural modifications the instrument can be adapted to the measurement of the brightness of surfaces as well as the illumination incident upon them.

Mr. R. ff. Pierce<sup>15</sup> has also produced an instrument of this same general class.

#### ILLUMINATION MEASUREMENTS

Practice in illumination measurements is so varied according to conditions governing any particular test, that to go into anything approaching a complete discussion would be beyond the scope of

<sup>15</sup> American Gas Light Journal, page 67, August 14, 1916.

this lecture. Certain general precautions, however, need to be taken in practically every case. Among the most important ones are the following:

To be sure that the comparison lamp in the photometer is giving its correct candle-power. This involves a comparatively recent standardization of the same taken in connection with its electrical measuring instrument, and an assurance that the electrical measuring instrument is sufficiently reliable and accurate for its purpose.

To use the photometer in such a way that there is no undue loss of light on the test-plate due to the presence of the operator or other person.

To select the test stations properly according to the design of the test.

To see that the test-plate is level and in the proper position.

To see that the scale readings are properly recorded and any condition such as the introduction of a neutral glass screen is noted.

The subject of precautions to be taken in illumination measurements has been quite fully treated by Little<sup>16</sup> in an Illuminating Engineering Society paper.

#### MEASUREMENT OF BRIGHTNESS

For many purposes it is desirable to know the brightness values of objects or of walls and ceiling in a room or of a shade or reflector of a lamp. The standard forms of portable photometers designed to measure illumination enable these measurements to be made simply by removing the test-plate, if there be one, and sighting the photometer directly on the object in question. Photometric balance is then secured between the object and the diffusing plate in the photometer. The reading of the scale needs to be multiplied by a constant to give the brightness value either in candle-power per square inch or in millilamberts.<sup>17</sup> The determination of this constant is a matter for the standardizing laboratory and is not particularly easy, inasmuch as it involves illuminating to a known degree a surface of known area which is then photometered as a source of light. It should be noted that the brightness constant of a photometer is a function only of the test-plate which is used with it, and that with changes in the calibration of a photometer this constant is unaffected, provided the test-plate is unchanged. The relation between the brightness constant expressed in apparent

<sup>16</sup> Little, Transactions I. E. S., Vol. 10, page 766, 1915.

<sup>17</sup> The millilambert is a unit of brightness, and is equal to the brightness of a perfectly reflecting and perfectly diffusing surface on which one millilumen per square centimeter falls.

lumens emitted per square foot, and the illumination which is the lumens incident per square foot, is evidently the transmitting or reflecting power of the test-plate according as the test-plate is of the transmitting or reflecting type. In practice in the standardizing laboratory it is convenient to have carefully preserved a standard test-plate of known brightness constant which can serve as a reference plate for the calibration of other plates.

#### DAYLIGHT MEASUREMENTS

For measuring daylight the use of a light filter to secure an approximate color match is indispensable. Inasmuch as the quality of daylight varies greatly, dependent upon the character of the sky, no one filter will enable a match to be made, but a single filter may in practice be used because the outstanding differences are not so excessive as to prevent fairly good measurements being made. On account of the very high values of illumination usually given by daylight, it is more convenient to put the filter on the daylight side rather than on the side of the comparison lamp. In the practice of the Electrical Testing Laboratories a sheet of suitably colored gelatin is sometimes utilized such as is employed in spot-lighting in theatrical work. Daylight foot-candle values alone are frequently, perhaps usually, of subsidiary importance because illumination values vary so much from time to time with the outdoor or sky conditions. Rather the photometrist must give a value at the place which is studied, coupled up in some way with a value representing outdoor conditions. The condition most commonly chosen is the brightness of some portion or of all of the visible sky, or the illumination produced by some portion of all of the visible sky. For this purpose various types of apparatus have been produced by which the brightness of the sky can be compared with the brightness of a test-plate in a room, for instance. As illustrative of this class of problems, the methods employed by the Electrical Testing Laboratories in studying the obstruction of daylight to buildings caused by alterations in a structure in the street will be instructive. In this work one photometer with a vertical test-plate was placed close to the window-line of the building. Alongside of it was another photometer having a fan-shaped arrangement placed over the test-plate whereby the test-plate received only the light from the unobstructed portion of the sky. (See Fig. 18.) Readings were made simultaneously with these photometers and thereby a relation was obtained between the illumination produced

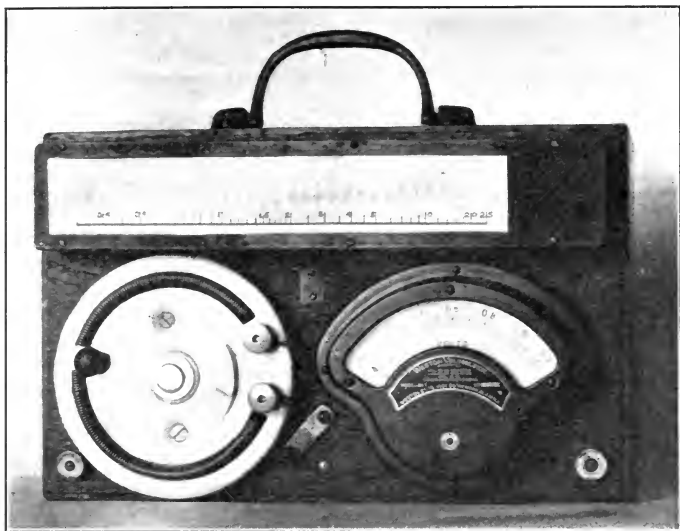

Fig. 17.—Simplified illumination tester.



Fig. 18.—Simultaneous measurements with two photometers in determining daylight conditions.

(Facing page 124.)

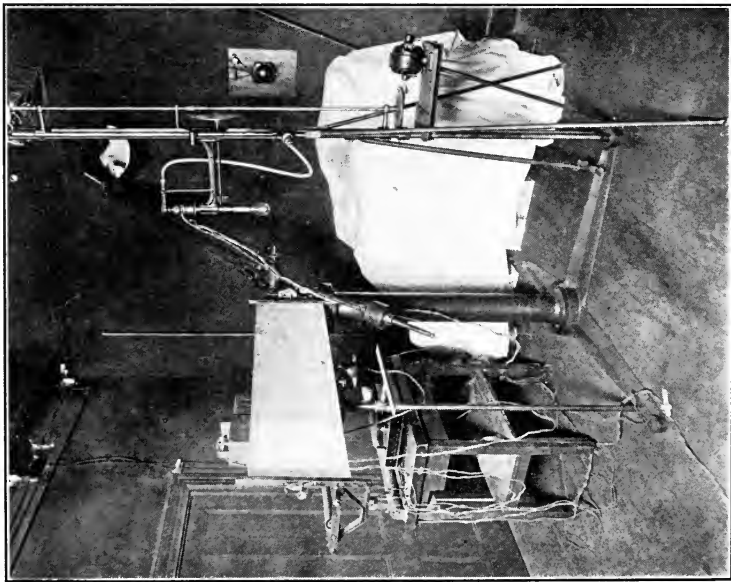

Fig. 19.—Little's distribution apparatus.

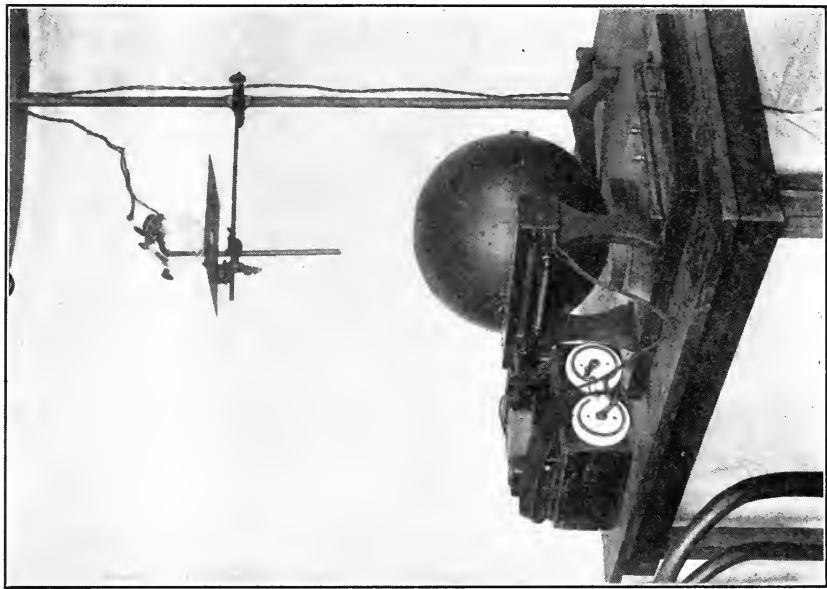

Fig. 20.—Measurement of transmission factor of diffusing glass.

by the sky independently of all structures, and the light entering the building. After alterations were completed, measurements of the same kind were repeated and the change in the ratio was taken to indicate the degree of light obstruction caused by the alterations. It was found that even with these precautions it was necessary to work only with an overcast sky of practically uniform brightness. Otherwise the relations did not hold. As an aid to carrying out measurements of this kind the instrument shown in Fig. 21 was

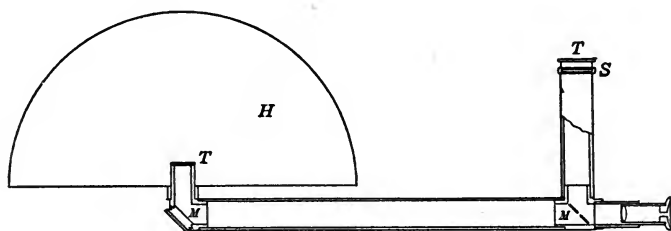

Fig. 21.—Instrument for daylight comparisons.

devised and constructed. In this instrument a direct comparison is obtained between the light falling on the vertical test-plate on one side and the test-plate turned toward the sky with a sky limiting device on the other.

#### PHOTOMETRY OF GAS-FILLED LAMPS

It was found at the Electrical Testing Laboratories that gas-filled lamps when rotated for the purpose of determining their mean horizontal candle-power, changed both in current consumption and in candle-power, and that this change varied with the speed of rotation. With high speed of rotation, centrifugal force causes the cooler portions of the gas in the interior of the bulb to be thrown off to the periphery of the bulb, leaving the filament surrounded by hotter gases than if it were stationary. Hence the temperature of the filament with the same watts input increases, and with it the candle-power and efficiency of the lamp.<sup>17</sup> This effect was discovered about the same time also by Middlekauff and Skogland<sup>18</sup> who found further that with very low speeds of rotation the candle-power of these lamps decreased, while it increased with higher speeds, so that for every lamp a speed can be found at which the candle-power and

<sup>17</sup> Sharp Photometry of gas-filled incandescent lamps, Trans. I. E. S., Vol. 9, page 1021, 1914.

<sup>18</sup> Photometry of the gas-filled lamp, Bulletin of Bureau of Standards, Vol. 12, page 589.

watts are the same as when stationary. The determination of the horizontal candle-power of gas-filled lamps is at the present time a matter of little importance, but it can best be accomplished by rotating the lamp quite slowly at or near this critical speed and placing behind it two mirrors 120 degrees apart so that the photometer disc is illuminated not only by the lamp itself but by its two reflected images resulting from beams equally directed about the periphery of the lamp. The two mirrors are employed to obviate the violent flicker on the photometer disc which would otherwise occur.

#### PHOTOMETRY OF LAMPS WITH SHADES AND REFLECTORS

The measurement of distribution of light about illumination accessories is carried on by methods which are well known and which were described in the Johns-Hopkins lectures. A new apparatus for the purpose designed by Little is shown in Fig. 19. In this apparatus there are only two mirrors and the record of the photometer settings is made on a paper fastened to a flat board in front of which the photometer carriage moves. The position of the board is changed for each change in the angle of the movable mirror. This apparatus is equally well adapted to the photometry of gas mantle burners and of incandescent electric lamps.

The determination of the diffusing power and of the absorption losses in lighting glassware is receiving more of the attention which it deserves. No standard method for the measurement of diffusion has yet been decided on, but a very good idea of the diffusing powers of glassware may be obtained by taking two measurements of the brightness of the glassware with its normal lamp inside of it; one with the photometer looking directly at the lamp and the other looking at a position on the globe about 45 degrees distant from the first position. It is desirable that methods of measuring diffusion should be further investigated and finally standardized.

The determination of absorption of globes or reflectors may be made through a comparison of the total flux of the light from a lamp without the globe and with it. The total flux may be found from distribution values worked up by means of the Rousseau or the Kennelly diagram, or by direct computation. More convenient, however, is the use of the integrating sphere. A good arrangement of the standard lamp and of the accessory in the sphere for determining the loss of light in the accessory is shown in Fig. 22. It will be noted that the standard lamp is placed with its

socket turned toward the globe and that the base of the globe is turned toward the standard lamp so that the sphere losses are minimized. The procedure then is as follows: With the globe removed from the sphere, the sphere is standardized or the photometer is adjusted to give a reading corresponding to the total flux of light from the standard lamp. Then the standard lamp is extinguished and the globe lamp is lighted. Reading the photometer then shows this total flux of light. It then is put out and the globe is placed

over it, the standard lamp is again lighted, and a reading is taken. This reading should be equal to the first one, excepting for the reflected flux in the sphere which is intercepted by the globe. Finally the standard lamp is extinguished and the globe lamp is lighted. This reading gives by comparison with the previous one the total flux of light issuing from the globe. This total flux of light compared with the total flux of light of the lamp without

the globe, reading No. 2, shows the absorption by the globe. It is very necessary to notice all the precautions which must be taken in this class of work as experimenters have been led into error by neglect of some of them.

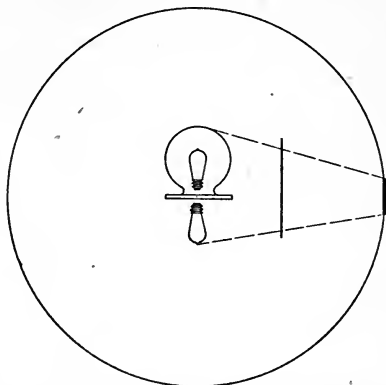

Fig. 22.—Arrangement for measuring globe absorption in integrating sphere.

#### REFLECTION AND TRANSMISSION MEASUREMENTS

Measurement of the transmission of light through a transparent medium such as a sheet of glass is most simply made by means of a bar photometer or portable photometer, measuring the candle-power of a lamp first without and then with the glass interposed in the beam. Similarly the reflecting power of a mirror can most readily be measured. When it comes to the measurement of diffusing media, either transmitting or reflecting, the measurement is more difficult. Inasmuch as diffusing media not only diminish the light but also change it from unidirectional into multidirectional light, some integrating device is in this case required. In this class of measurements the integrating sphere may very suitably be used.



In Fig. 20 is shown a view of a 12-inch sphere set up to measure the transmission of a diffusing glass. There is an opening of definite diameter in the top of the sphere, limited by a circular metal diaphragm, and the light from the lamp outside the sphere shines through this into the interior. Photometric measurement gives the value of this luminous flux. Then the diffusing glass is placed directly beneath the limiting diaphragm and another measurement is made which gives the amount of flux traversing the glass. In the case of diffuse reflectors the procedure is somewhat different. Fig. 23 shows the arrangement. The diffuse reflector which, as will be

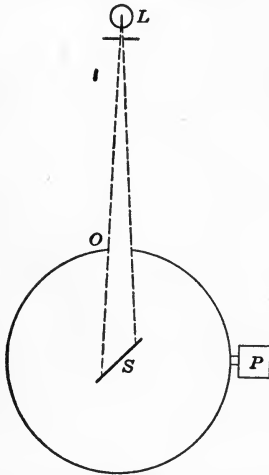

Fig. 23.—Measurement of coefficient of diffuse reflection, using an integrating sphere.

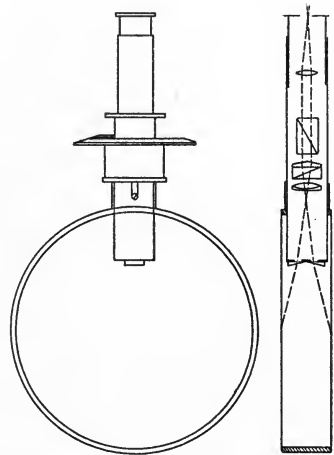

Fig. 24.—Nutting's apparatus for measuring coefficients of reflection.

seen, is placed at the center of the sphere with its reflecting side turned at an angle of 45 degrees to the light and away from the photometer. Thus no screen is needed in the sphere. The amount of flux admitted by the diaphragm being known, and the amount reflected from the diffusing surface being measured, the reflection coefficient at this angle of incidence can be computed. One method by which the amount of light admitted to the sphere can be checked up under similar conditions to those of the measurement of the reflected flux, is to place a mirror of known coefficient of reflection in the position occupied by the diffuse reflector. The amount of flux then measured divided by the known coefficient of reflection of the mirror, gives the amount of flux incident upon the diffuse reflector.

A singularly ingenious and elegant piece of apparatus for the measurement of coefficients of diffuse reflection has been devised by Nutting.<sup>20</sup> This instrument is shown in plan in Fig. 24. The ring in the figure is covered on the upper surface by a dense milk glass. On the under surface it is covered by the diffuse reflector which is to be tested. A special photometric device is supplied whereby the brightness of the under surface of the milk glass may be compared with the brightness of the diffuse reflector. If a diffuse reflector had 100 per cent. reflecting power, its brightness would be the same as that of the milk glass. Any deficiency is due to its absorption. The photometer, which is a Martens-König polarization apparatus, gives a comparison between the two directly, and hence shows the reflecting power of the unknown surface. Direct and reverse readings must be taken in order to eliminate polarization errors.

#### MEASUREMENTS OF PROJECTION APPARATUS

The elementary theory of a projector having a convex lens or a parabolic mirror and a nearly point source shows that when the source is placed at the principal focus of the mirror, the light rays leave the surface of the mirror with an angle of divergence which is equal to the angle subtended at that particular point of the mirror by the source of light. Therefore the illumination obtained from an apparatus of this kind diminishes with the distance, and if the distance is great enough, the exponent of the distance with which it diminishes is two. In other words, the illumination from the entire apparatus follows the inverse square law. With a small projecting apparatus accurately focused for "parallel" beam, it is not necessary to take any very great distance away in order to have the inverse square law apply. A goodly distance is, however, in all cases advisable, and in some cases imperative. For example, in the case of head-lamps which are focused so as to throw an imperfect image of the source of light a distance of 200 or 300 feet ahead, it is evident that the inverse square law could not be assumed without taking a distance considerably greater than 200 or 300 feet. Sometimes the focusing distance is shorter than this. In any case, in the photometric investigation of an apparatus which is to be used approximately at a certain distance, it is advisable to focus it for that distance and to make the measurement at that distance. These measurements can then be expressed as apparent candle-power of the

<sup>20</sup> Nutting, Trans. I. E. S., Vol. 8, page 412, 1912.

apparatus at that distance, and in so doing the inverse square law is not assumed. It is evident that measurements of this character must perforce be made at night and that the portable photometer is practically the only apparatus that can be used for the purpose. It is advantageous to set the projector on a stand which can be rotated about a vertical axis and which has a divided scale whereby the angle at which the measurement is taken may be read off. By taking a series of measurements covering a few degrees on either side of the axis of the beam, data may be gathered whereby a candle-power distribution curve may be plotted. In view of the narrowness of such a beam a plot in polar coördinates is as a general thing of little use. It is good practice to plot these measurements in rectangular coördinates, putting angles in the axis of  $X$  and apparent candle-power in the axis of  $Y$ . If this distribution curve is carried far enough, it may be integrated according to the Rousseau method and the total flux of light emitted by the apparatus thereby determined. This, compared with the total flux of the lamp alone, gives the loss of light in the apparatus. A plot so made enables the exact position of the maximum candle-power, which should be the beam candle-power, to be determined. In the case of lamps for flood lighting the efficiency of the apparatus is of great importance and hence a minimum loss of light in it should be striven for, more perhaps than is the case with projectors. The value of the lost light may in this case most readily be determined by the use of the integrating sphere.

# RECENT DEVELOPMENTS IN ELECTRIC LAMPS

BY G. H. STICKNEY

## INTRODUCTION

Lectures by Drs. Steinmetz,<sup>1</sup> Hyde<sup>2</sup> and Whitney,<sup>3</sup> in the 1910 Course, treated of the physical and chemical principles of light production, and described the electric illuminants from the scientific standpoint.

On this foundation it is the purpose of this lecture to trace the more important of the recent developments and describe briefly the principal lamps now in common use.

From the great mass of available data, an attempt is made to present such information as will be of most practical value in selecting and applying electric lamps.

Since arc lamps are usually furnished as complete units they are so treated. Incandescent lamps, however, are equipped with a great variety of reflectors and other accessories, which are furnished separately. It has, therefore, been found most expedient to provide a separate lecture on such accessories<sup>4</sup> and give but slight reference to them in this lecture.

## LAMP DEVELOPMENT

The basis of all artificial lighting is the means for converting electrical or other energy into light. Advances in the lighting art have followed in the wake of the improved, practical light source, and it is here that the greatest possibility for future advance lies. The most efficient illuminants are still very far below the ideals of efficiency, while many of them offer much opportunity for improvements, as regards reliability, convenience and maintenance.

Few, if any of the recent improvements in light producers have come by chance. They have rather been the result of arduous and expensive research by trained physicists, chemists and engineers in well organized laboratories. Even when an improved principle of light production has been discovered, practical devices have had to be designed, machinery for manufacturing economically and in quantity developed, sizes and other characteristics determined upon, in order that the improvement could be utilized to advantage.

While all these items cannot be perfected in advance of the practical application of the appliance, it is remarkable how few changes are necessary. It is a tribute to Thomas A. Edison that so many of his standards still hold.

#### PROGRESS SINCE 1910

In general, the progress since 1910 may be summed up in (a) improved efficiency, (b) reliability and safety, (c) economy of maintenance, (d) adaptability, (e) simplicity and convenience.

Accompanying these improvements there has been a corresponding increase in intrinsic brilliancy of light sources, which, while advantageous for certain applications, has in general been undesirable. Fortunately, however, diffusing devices can be readily applied, giving an over-all result much in favor of the improved illuminants.

#### TENDENCY AS TO TYPES

Among the incandescent units the tungsten filament or "Mazda" lamp has assumed predominance. The tantalum and Nernst lamps have practically disappeared from manufacture, while the use of metallized-carbon filament or "Gem" and carbon lamps has decreased very rapidly in the last four years.

The actual percentages reported by the National Electric Light Association<sup>5</sup> show that approximately 80 per cent. of all incandescent lamps sold during 1915 in this country were of the tungsten filament type. Incandescent lamps, as a whole, have increased in importance, encroaching on fields of lighting formerly assigned to other illuminants.

While many enclosed carbon arc lamps are still in use, especially in street lighting, their manufacture has dwindled to a very small number, giving way to more efficient illuminants. The flaming arc has been changed from an open to an enclosed lamp, and has been applied to street, industrial and photographic lighting whereas formerly its principal application was spectacular lighting.

The "luminous," "magnetite" or "metallic flame" arc lamp has become one of the leading street illuminants, especially since the ornamental types became available, while the multiple lamp used in industrial lighting is not now exploited.

#### CLASSIFICATION

Steinmetz<sup>1</sup> classified electric illuminants as (a) solid conductor, (b) gaseous conductor, (c) arc conductor, and (d) vacuum arc. For

the present lecture, a similar classification, with the more common names, is used, namely, (a) incandescent lamp (Mazda, etc.), (b) Moore lamp and X-Ray tube, (c) arc lamp (luminous and flame), (d) mercury vapor lamp (Cooper Hewitt).

### INCANDESCENT LAMPS

Of the incandescent lamps, the only types meriting our consideration are the tungsten-filament lamps, designated by the principal American manufacturers as "Mazda."

The principal distinct developments since 1910 are (a) drawn tungsten filaments, (b) coiled filaments, (c) concentrated filaments, (d) chemical "getters," (e) gas-filled construction.

In addition to these, however, there have been innumerable minor improvements, which have resulted in large aggregate gains in efficiency and have tended toward uniformity, increased strength<sup>8</sup> and reduced cost.<sup>9</sup>

For example, it is very largely due to the minor improvements that the 60-watt lamp of to-day costs one-third less than in 1910 and gives 20 per cent. more light.

*Drawn Wire Filaments.*—Drawn wire filaments superseded the former pressed filaments in about 1911. The ductile form of tungsten<sup>6</sup> was finally produced in the Research Laboratory at Schenectady,<sup>7</sup> after extended experiments and many discouraging failures.

It revolutionized lamp manufacture, simplifying the processes very considerably and reducing the cost. Further, it became possible to draw filaments exactly to size, which in turn, increased the practical efficiency by eliminating weak points, and also made it possible for the first time in lamp manufacture to produce all lamps of a lot for the predetermined voltage. The economic influence of this last factor is being felt to-day in the demand for standardization of circuit voltages.

With the development of the drawn wire processes, the lamps became much more rugged, so that to-day they are widely used in steam and trolley cars, automobiles, on moving machinery and in other relatively rough service.

The drawn wire could also be made more slender, so that the 10-watt and even the 7.5-watt, 110-volt lamps became practicable.

*Coiled Filaments.*—Another result of the use of ductile tungsten was the possibility of winding the wire around a mandrel, thereby producing the helically coiled filament (See Fig. 1).

The first application of this was in the so-called "focus" type

lamp, in which the filament was concentrated into a small space, more or less approximating the point source. The automobile and locomotive headlight lamps and a much more effective stereopticon lamp became practicable.<sup>10</sup>

The advantage of the concentrated light source in connection with lenses and reflectors is illustrated in Table I, which shows the maximum beam candle-power obtained with a 16-in. parabolic reflector (G. E. Floodlighting projector Form L-1) with lamps of approximately 100 watts, but with widely varying filament dimensions. In these tests the lamps were focused so as to give maximum beam candle-power and operated at 100 mean spherical candle-power.

TABLE I.—BEAM CANDLE-POWERS

Mazda lamp used				Light source dimensions m.m.		Beam candle-power
Volt	Watt	Bulb	Type	Dia.	Length	
6	108	G-30	C headlight	2.0	6.5	462,000
32	100	G-30	C headlight	5.0	5.0	223,000
110	100	G-25	C stereopticon	6.5	6.5	142,000
110	100	G-30	B stereopticon	8.0	8.0	32,600
110	100	PS-25	C regular	25	0.5	12,700
110	100	G-35	B regular	30	68	3,800

The most important effect of the coiled filament, however, is in connection with the gas-filled construction.

*Chemical "Getters."*—This refers to the introduction of various chemicals, sometimes called "getters," within the lamp. Some of these chemicals act while the lamp is being exhausted, while others continue to act throughout the life of the lamp. Some of the important effects of these chemicals are:

1. Regeneration, that is, redepositing evaporated material on the filament.
2. Combination with material depositing upon the bulb to form more transparent compounds.

These combined actions permit increased efficiency, reduce bulb blackening,<sup>11</sup> and help maintain the candle-power of the lamp throughout its rated burning life.

#### GAS-FILLED LAMPS

With the elimination of several weak points, it had been possible to raise filament temperatures of vacuum lamps, and hence efficien-

cies, to a point corresponding to about one watt per candle-power, beyond which filament evaporation seemed to preclude much further advance.

The announcement in 1913, of lamps consuming approximately one-half watt per candle-power was, therefore, rather astounding to the lighting world. This came as the result of a remarkable research<sup>12</sup> in the same laboratory that produced ductile tungsten. The new principle which involved the gas-filled construction, depended upon the fact that when operated under a moderate gas pressure, the tungsten filament could be maintained at a higher temperature without excessive evaporation.

The introduction of gas within the bulb, however, incurred a new loss; namely, convection, that is, heat carried off by gas currents. Such losses are relatively less on filaments of large diameter, so that high current lamps are more efficient than low. By using the helically coiled filament, as already referred to, and thereby simulating large diameter, it was possible to apply the principle to practical lamps (see Fig. 1). Later, by selection of gas of low heat conduction, it became practicable to extend it to lower currents; for example, 100-watt and 75-watt 110-volt multiple lamps. The gas-filled construction is most advantageous with high current series lamps and high wattage multiple lamps. On the lower wattage multiple lamps, it as yet gives lower efficiency than the vacuum type of construction, and hence is not employed. In the larger sizes, however, the gas-filled lamps, which are designated by the leading American manufacturers as "Mazda C," are extensively used, their high candle-power and efficiency being responsible for extending the application into fields not formerly occupied by incandescent lamps.

Owing to the higher filament temperature the light is perceptibly whiter<sup>13</sup> and more actinic, than that of the vacuum type "Mazda B" lamps. Lamps having ratings of up to and including 1000 watts (18,000 lumens) are in regular production. Larger lamps have been made and could readily be provided if there was sufficient commercial demand.

Since all the series lamps in common use are of relatively high current, the gas filled lamps are especially advantageous, and have superseded the vacuum lamps all along the line.

A still further gain is secured for the higher power series lamps by providing 15- and 20-amp. lamps, to be operated from the usual alternating current series circuits; namely, 6.6 and 7.5 amp., by means of individual auto-transformers or series transformers.



The concentrated arrangement of filament permits of a more effective control of the candle-power distribution with refracting globes and small diameter reflectors.

*Candle-power Distribution.*—Formerly all clear incandescent lamps had practically the same distribution of candle-power, so that the mean horizontal candle-power bore a practically fixed relation to the mean spherical candle-power, and to the total light output. With the recent development, several forms of filaments, having various candle-power distributions (see Fig. 2) are used in the different lamps. Therefore, the mean horizontal candle-power is no longer a representative measure of light output.

*Position of Operation.*—As in the past, the smaller lamps can be operated in any position. It has been found advantageous, however, to construct some of the larger lamps (for example, multiple lamps of 200 or more watts) without bottom anchors on the filaments. Such lamps may not operate satisfactorily in other than an approximately pendant position.

It is seldom desirable to operate these larger lamps in horizontal, tip-up, or inclined positions, but where such is the case, special lamps can be obtained, if the position of operation is specified.

Some of the high-power focus type lamps, on the other hand, should not be operated within  $45^\circ$  of the pendent position. Such lamps are usually operated tip up or horizontally. In order to economize space in housings, these lamps are made short so that if used pendant it is not practicable to protect the stems from heated gases rising from the filament.

Accessories for focus type lamps should therefore be planned for proper lamp position according to information given by the lamp manufacturers.

*Circuits.*—It is highly desirable to operate incandescent lamps at rated voltage or current. While low voltage does no harm, beyond lowering the light output and efficiency, and also changing the color of the light, continued low voltage is often a source of complaint from light users. Over-voltage shortens the life of the lamps and if excessive may destroy the filament.

While lamps have sufficient leeway to permit operation at a reasonable over-voltage and so operated are usually more economical, the practice of running lamps at labeled voltage is generally preferred and is recommended by the manufacturers.

Incandescent lamps operate interchangeably and equally well on alternating-current and direct-current circuits. The only ex-

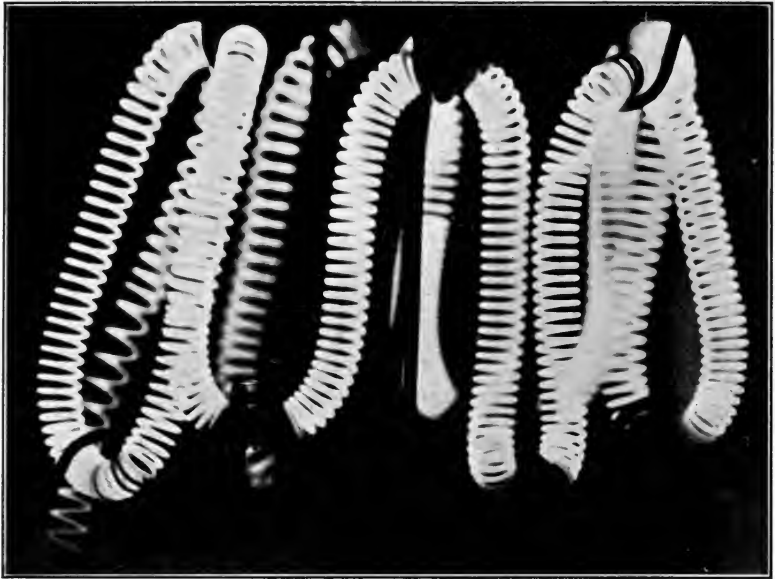

Fig. 1.—Helically coiled filament of tungsten wire. (Magnified to show turns.) Illustration also shows concentrated arrangement of filament for a focus type lamp. Note the cooling effect of supporting anchors on the heated filament.

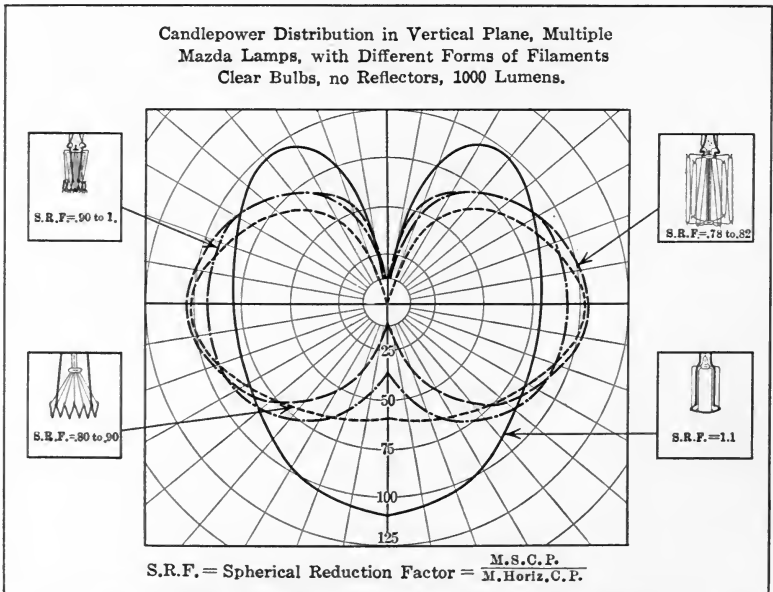

Fig. 2.—Curves of candle-power distribution in vertical plane, multiple Mazda lamps, with different forms of filament.

(Facing page 136.)

(Lamps 1/4 Scale)

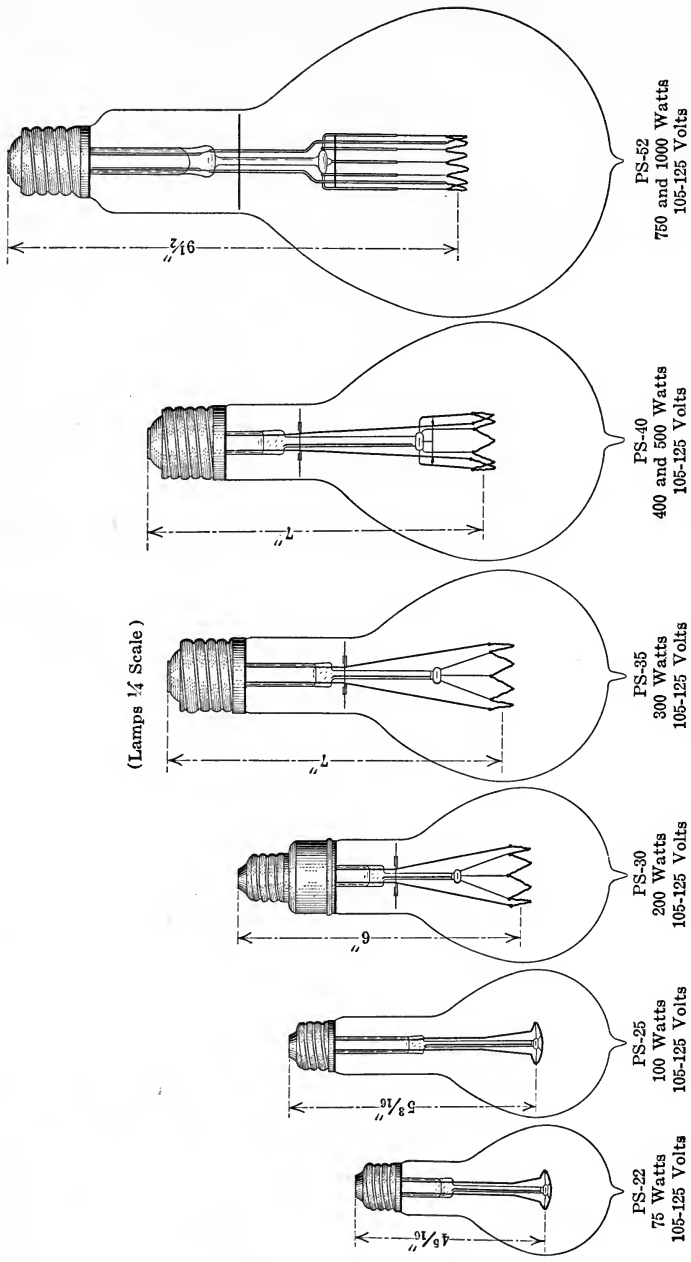

Fig. 3.—Regular (mazda C) gas-filled lamps for 110-volt circuits.

ceptions to this are the non-vacuum series lamps which can be operated to best advantage on alternating-current circuits.

Although the lamps give satisfactory life on series direct current, on the failure of the lamp, there is sometimes maintained a lower voltage arc, which may burn the socket contacts before the protective film acts.

On account of the low heat capacity of slender filaments, 110 volts of 25 watts or less (220 volt lamps of 60 watts or less) show perceptible flicker on 25-cycle circuits,<sup>15</sup> which may be objectionable. Lamps made for higher amperage avoid this effect. In general 110-volt lamps are a little more efficient and of lower cost than 220-

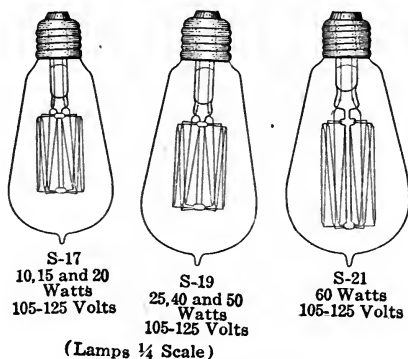

Fig. 4.—Regular (Mazda B) vacuum lamps for 110-volt circuits.

volt lamps. While the 220-volt lamps are made for the same operating life, 110-volt circuits should usually be preferred.

*Styles and Types.*—Where possible lamps as listed by the manufacturer should be used. Special lamps should be avoided. Higher costs, slower deliveries and poorer quality may be expected on special lamps. The present lists include lamps to cover practically all needs.

Data on some of the principal types of Mazda lamps are given in Table II. These data are subject to some change as improvements become available.

The variety of incandescent lamps is so great that it is impracticable to give full lists. It is worth while to call attention to some of the more special types which come into common use, but are not so well known as the regular types.

TABLE II.—ENGINEERING DATA ON MAZDA LAMPS, JULY, 1916

Watts	Input Watts per spherical c.p.	Output Lumens per watt	Total lumens	Reduction factor	Bulb			Base	Standard package quantity	Position of burning	Light center length (Inches)
					Type	Diam. (inches)	Max. over-all length (inches)				
<b>105-125 VOLT "B" STRAIGHT SIDE BULBS (Fig. 4)</b>											
10	1.67	7.50	75	0.78	S-17	2½	4¾	Med. screw	100	Any	
15	1.47	8.55	128	0.78	S-17	2½	4¾	Med. screw	100	Any	
20	1.41	8.90	178	0.78	S-17	2½	4¾	Med. screw	100	Any	
25	1.35	9.30	234	0.78	S-19	2¾	5¼	Med. screw	100	Any	
40	1.32	9.50	380	0.78	S-19	2¾	5¼	Med. screw	100	Any	
50	1.31	9.60	480	0.78	S-19	2¾	5¼	Med. screw	100	Any	
60	1.28	9.80	590	0.78	S-21	2¾	5½	Med. screw	100	Any	
100	1.22	10.3	1030	0.78	S-30	3¾	7¾	Med. sc. sk.	24	Any	
<b>105-125 VOLT "C" PEAR-SHAPE BULBS (Fig. 3)</b>											
75	1.09	11.5	865	....	PS-22	2¾	6½	Med. screw	50	Any	4½ <sup>16</sup>
100	1.00	12.6	1260	....	PS-25	3¾	7¾	Med. screw	24	Any	5½ <sup>16</sup>
200	0.90	14.0	2800	....	PS-30	3¾	8¾	Med. sc. sk.	24	Tip down	6
300	0.82	15.3	4600	....	PS-35	4¾	9¾	Mog. screw	24	Tip down	7
400	0.82	15.3	6150	....	PS-40	5	10	Mog. screw	12	Tip down	7
500	0.78	16.1	8050	....	PS-40	5	10	Mog. screw	12	Tip down	7
750	0.74	17.0	12800	....	PS-52	6½	13¾	Mog. screw	8	Tip down	9½
1000	0.70	18.0	18000	....	PS-52	6½	13¾	Mog. screw	8	Tip down	9½
<b>220-250 VOLT "B" STRAIGHT SIDE BULBS</b>											
25	1.65	7.60	191	0.79	S-19	2¾	5¼	Med. screw	100	Any	
40	1.42	8.85	354	0.79	S-19	2¾	5¼	Med. screw	100	Any	
60	1.39	9.05	540	0.79	S-21	2¾	5½	Med. screw	100	Any	
100	1.27	9.90	990	0.79	S-30	3¾	7¾	Med. sc. sk.	24	Any	
150	1.27	9.90	1480	0.79	S-35	4¾	8¾	Med. sc. sk.	24	Any	
250	1.20	10.5	2620	0.79	S-40	5	10	Med. sc. sk.	12	Any	
<b>220-250 VOLT "C" PEAR-SHAPE BULBS</b>											
200	1.00	12.6	2520	....	PS-30	3¾	8¾	Med. sc. sk.	24	Tip down	6
300	0.92	13.7	4100	....	PS-35	4¾	9¾	Mog. screw	24	Tip down	7
400	0.90	14.0	5600	....	PS-40	5	10	Mog. screw	12	Tip down	7
500	0.85	14.8	7400	....	PS-40	5	10	Mog. screw	12	Tip down	7
750	0.82	15.3	11500	....	PS-52	6½	13¾	Mog. screw	8	Tip down	9½
1000	0.78	16.1	16100	....	PS-52	6½	13¾	Mog. screw	8	Tip down	9½
<b>105-125 VOLT "B" ROUND BULBS (Fig. 5)</b>											
15	1.53	8.20	123	0.80	G-18½	2½ <sup>16</sup>	3¾	Med. screw	100	Any	
15	1.43	8.80	132	0.80	G-25	3¾	4¾	Med. screw	50	Any	
25	1.41	8.90	222	0.80	G-18½	2½ <sup>16</sup>	3¾	Med. screw	100	Any	
25	1.31	9.60	240	0.80	G-25	3¾	4¾	Med. screw	50	Any	
40	1.30	9.65	386	0.80	G-25	3¾	4¾	Med. screw	50	Any	
60	1.20	10.5	630	0.80	G-30	3¾	5½	Med. screw	24	Any	
100	1.14	11.0	1100	0.80	G-35	4¾	7¼	Med. sc. sk.	24	Any	
<b>220-250 VOLT "B" ROUND BULBS</b>											
25	1.50	8.40	210	0.80	G-25	3¾	4¾	Med. screw	50	Any	
40	1.41	8.90	356	0.80	G-25	3¾	4¾	Med. screw	50	Any	
<b>105-125 VOLT "B" TUBULAR BULBS (Fig. 5)</b>											
25	1.35	9.30	232	0.78	T-10	1¼	5½	Med. screw	100	Any	
25	1.44	8.75	218	....	T-8	1	12	Med. screw	50	Any	
40	1.39	9.05	362	....	T-8	1	12	Med. screw	50	Any	

TABLE II.—ENGINEERING DATA ON MAZDA LAMPS, JULY, 1916.—(Continued)

SIGN, STEREOPTICON AND FLOODLIGHTING LAMPS

Watts	Watts per spherical c.p.	Lumens per watt	Total lumens	Reduction factor	Bulb			Base	Standard package quantity	Position of burning	Light center length (inches)
					Type	Diam. (inches)	Max. over-all length (inches)				
<b>10½-12½ VOLT "B" SIGN STRAIGHT SIDE BULBS</b>											
2½	1.52	8.25	20.6	0.79	S-14	1¾	4	Med. screw	100	Any	
5	1.46	8.60	43.0	0.79	S-14	1¾	4	Med. screw	100	Any	
<b>50-65 VOLT "B" SIGN STRAIGHT SIDE BULBS</b>											
5	1.73	7.25	36.2	0.78	S-14	1¾	4	Med. screw	100	Any	
<b>105-125 VOLT "B" SIGN STRAIGHT SIDE BULBS</b>											
7½	1.92	6.55	49.0	0.78	S-14	1¾	4	Med. screw	100	Any	
10	1.73	7.25	72.5	0.78	S-14	1¾	4	Med. screw	100	Any	
<b>105-125 VOLT "C" STEREOPTICON—ROUND BULBS</b>											
100	1.00	12.6	1260	....	G-25	3¾	5	Med. screw	50	•	3
250	0.80	15.7	3950	....	G-30	3¾	5½	Med. screw	24	•	3½
500	0.67	18.8	9400	....	G-40	5	7¼	Mog. screw	12	•	4¼
<b>105-125 VOLT FLOOD LIGHTING "C"</b>											
200	0.95	13.2	2640	....	G-30	3¾	5½	Med. screw	24	•	3½
400	0.85	14.8	5920	....	G-40	5	7¼	Mog. screw	12	•	4¼

\* Can be operated in any position except within 45 degrees of vertical, base up.

MAZDA STREET LIGHTING LAMPS

Nominal rated c.p.	Total lumens	Average volts	Average watts	Input watts per spherical c.p.	Output lumens per watt	Bulb			Base	Standard package quantity	Position of burning	Light center length (inches)
						Type	Diam. (inches)	Max. over-all length (inches)				
<b>5.5-AMP. "C" STREET SERIES STRAIGHT SIDE AND PEAR-SHAPE BULBS (Fig. 7)</b>												
60	600	8.5	46.8	0.98	12.8	S-24½	3½	7¼	Mog screw	50	Any	5¾
80	800	10.8	59.5	0.93	13.5	S-24½	3½	7¼	Mog. screw	50	Any	5¾
100	1000	13.0	71.5	0.90	14.0	S-24½	3½	7¼	Mog. screw	50	Any	5¾
250	2500	29.7	163.0	0.82	15.3	PS-35	4¾	9¾	Mog. screw	24	Tip down	7
400	4000	47.4	260.0	0.82	15.3	PS-40	5	10	Mog. screw	12	Tip down	7
<b>6.6-AMP. "C" STREET SERIES STRAIGHT SIDE AND PEAR-SHAPE BULBS (Fig. 7)</b>												
60	600	7.1	46.8	0.99	12.7	S-24½	3½	7¼	Mog. screw	50	Any	5¾
80	800	9.1	60.0	0.94	13.4	S-24½	3½	7¼	Mog. screw	50	Any	5¾
100	1000	10.9	72.0	0.90	14.0	S-24½	3½	7¼	Mog. screw	50	Any	5¾
250	2500	23.5	155.0	0.78	16.1	PS-35	4¾	9¾	Mog. screw	24	Tip down	7
400	4000	37.1	244.0	0.77	16.3	PS-40	5	10	Mog. screw	12	Tip down	7
600	6000	55.7	368.0	0.77	16.3	PS-40	5	10	Mog. screw	12	Tip down	7
<b>7.5-AMP. "C" STREET SERIES STRAIGHT SIDE AND PEAR-SHAPE BULBS (Fig. 7)</b>												
60	600	6.4	48.0	1.00	12.6	S-24½	3½	7¼	Mog. screw	50	Any	5¾
80	800	8.0	60.0	0.94	13.4	S-24½	3½	7¼	Mog. screw	50	Any	5¾
100	1000	9.6	72.0	0.90	14.0	S-24½	3½	7¼	Mog. screw	50	Any	5¾
250	2500	19.6	147.0	0.74	17.0	PS-35	4¾	9¾	Mog. screw	24	Tip down	7
400	4000	30.5	228.0	0.72	17.5	PS-40	5	10	Mog. screw	12	Tip down	7
600	6000	45.8	344.0	0.72	17.5	PS-40	5	10	Mog. screw	12	Tip down	7
<b>15-AMP. "C" STREET SERIES PEAR-SHAPE BULBS (Fig. 7)</b>												
400	4000	14.4	216	0.68	18.5	PS-40	5	12½	Mog. screw	12	Tip down	9½
<b>20-AMP. "C" STREET SERIES PEAR-SHAPE BULBS (Fig. 7)</b>												
600	6000	15.5	310	0.65	19.3	PS-40	5	12½	Mog. screw	12	Tip down	9½
1000	10000	25.9	520	0.65	19.3	PS-40	5	12½	Mog. screw	12	Tip down	9½

TABLE II.—ENGINEERING DATA ON MAZDA LAMPS, JULY, 1916.—(Continued)

## MAZDA TRAIN LIGHTING LAMPS

Watts	Input		Output		Total lumens	Reduction factor	Bulb			Base	Standard package quantity	Position of burning	Light center length (Inches)
	Watts per spherical c.p.	Lumens per watt	Type	Diam. (Inches)			Max. Over all Length (Inches)						
<b>25-34 VOLT AND 50-65 VOLT "B" TRAIN LIGHTING ROUND BULBS</b>													
10	1.44	8.75	87	0.81	G-18½	2½ <sup>1</sup> / <sub>16</sub>	3¾	Med. screw	100	Any			
15	1.38	9.10	137	0.81	G-18½	2½ <sup>1</sup> / <sub>16</sub>	3¾	Med. screw	100	Any			
20	1.36	9.25	185	0.81	G-18½	2½ <sup>1</sup> / <sub>16</sub>	3¾	Med. screw	100	Any			
25	1.36	9.25	232	0.81	G-18½	2½ <sup>1</sup> / <sub>16</sub>	3¾	Med. screw	100	Any			
40	1.22	10.3	412	0.82	G-30	3¾	6¼	Med. sc. sk.	24	Any			
†75	1.16	10.8	810	0.82	G-30	3¾	6¼	Med. sc. sk.	24	Any			
<b>25-34 VOLT AND 50-65 VOLT TRAIN LIGHTING STRAIGHT SIDE BULBS</b>													
10	1.50	8.40	84	0.78	S-17	2½ <sup>1</sup> / <sub>8</sub>	4½	Med. screw	100	Any			
15	1.44	8.75	131	0.78	S-17	2½ <sup>1</sup> / <sub>8</sub>	4½	Med. screw	100	Any			
20	1.41	8.90	178	0.78	S-17	2½ <sup>1</sup> / <sub>8</sub>	4½	Med. screw	100	Any			
25	1.41	8.90	222	0.78	S-19	2¾	5¼	Med. screw	100	Any			
40	1.28	9.80	392	0.78	S-19	2¾	5¼	Med. screw	100	Any			
<b>5½ AND 6 VOLT "C" LOCOMOTIVE HEADLIGHT ROUND BULBS</b>													
36	0.85	14.8	*530	....	G-18½	2½ <sup>1</sup> / <sub>16</sub>	3¾	Med. screw	100	Any		2½ <sup>1</sup> / <sub>16</sub>	
72	0.80	15.7	*1130	....	G-25	3½	4¾	Med. screw	50	Any		2¾	
108	0.75	16.8	*1810	....	G-30	3¾	5½	Mog. screw	24	Any		3½	
<b>30-34 VOLT "C" LOCOMOTIVE HEADLIGHT ROUND BULBS</b>													
100	1.00	12.6	1260	....	G-25	3½	4¾	Med. screw	50	Any		2¾	
150	0.90	14.0	2100	....	G-25	3½	4¾	Med. screw	50	Any		2¾	
250	0.80	15.7	3920	....	G-30	3¾	5½	Med. screw	24	†		3½	

\* 6 volt lamp only; 5½ volt lamp, 6¼ per cent. less.†

† Can be operated in any position except within 45 degrees of vertical, base up.

‡ 30-34 and 60-65 volts.

## MAZDA STREET RAILWAY LAMPS

Watts	Input		Output		Total lumens	Reduction factor	Bulb			Base	Standard package quantity	Position of burning	Light center length (Inches)
	Watts per spherical c.p.	Lumens per watt	Type	Diam. (Inches)			Max. over all Length (Inches)						
<b>105, 110, 115, 120, 125 AND 130 VOLT "B" STREET RAILWAY STRAIGHT SIDE BULBS</b>													
†23	1.42	8.85	*218	0.78	S-19	2¾	5¼	Med. screw	100	Any			
†36	1.40	9.00	*354	0.78	S-19	2¾	5¼	Med. screw	100	Any			
†56	1.31	9.60	*570	0.78	S-21	2¾	5½	Med. screw	100	Any			
†94	1.24	10.1	*1000	0.78	S-24½	3½ <sup>1</sup> / <sub>16</sub>	7½	Med. sc. sk.	50	Any			

\* 115 volt lamps only, other lamps in proportion to their volts.

† Nominal watts.

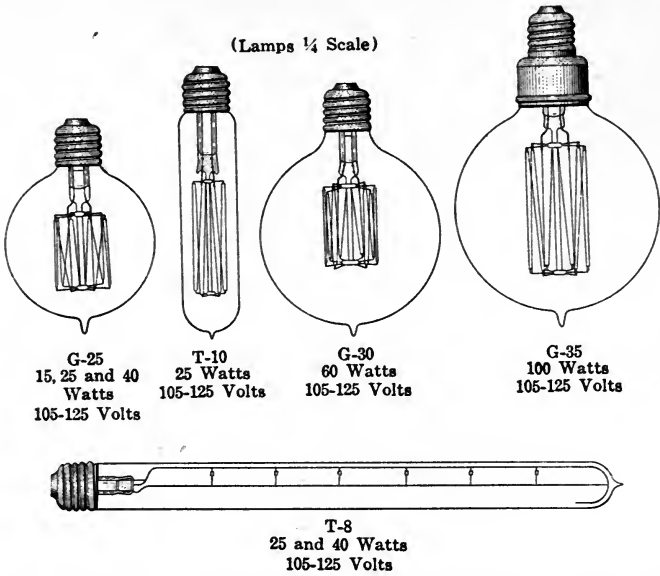

Fig. 5.—Round bulb and tubular (Mazda B) vacuum lamps for 110-volt circuits.

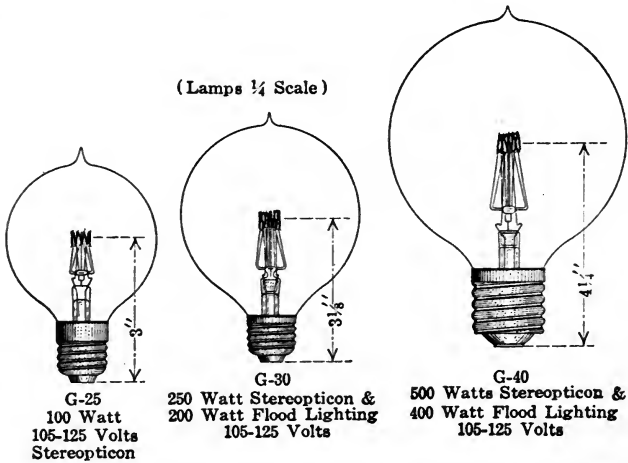

Fig. 6.—Floodlighting and stereopticon (Mazda C) gas-filled lamps for 110-volt circuits.



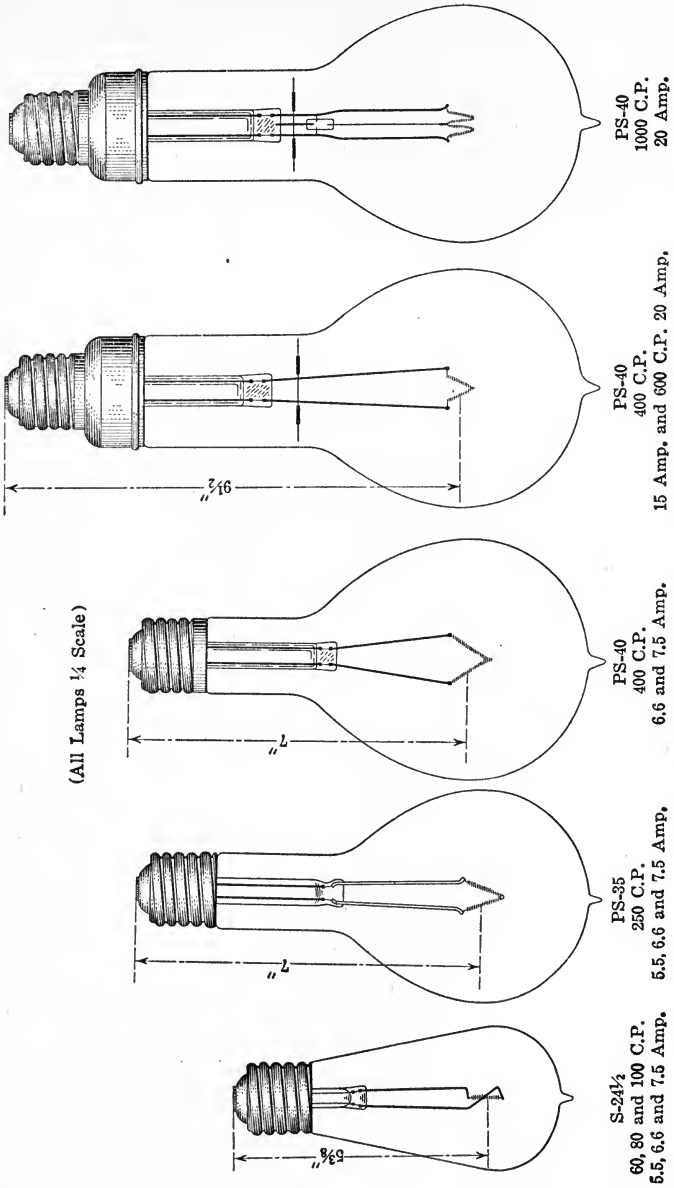

Fig. 7.—Street series (Mazda C) gas-filled lamps.

*Focus Type Lamps.*—These lamps are especially designed for use with lenses and parabolic reflectors. They are used with stereopticons, small moving-picture machines, signals, and for spotlighting, floodlighting, headlighting, etc.<sup>10</sup> The essential feature of the lamps is the concentration of the filament to approximate the “point source.”

*Miniature Lamps.*—This term is applied to a wide variety of small lamps used for many special purposes. Such lamps are usu-

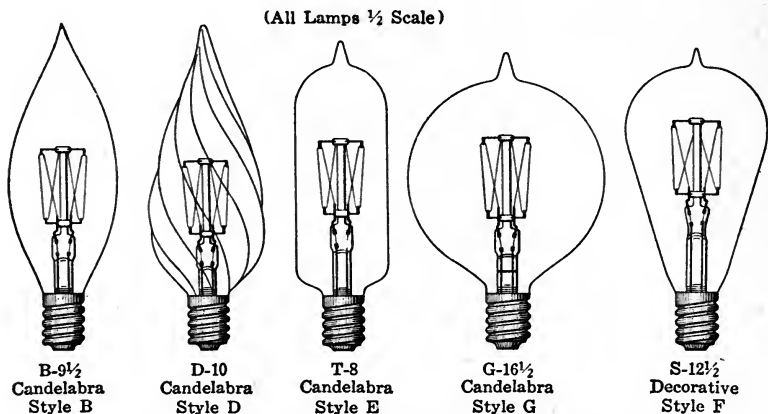

Fig. 8.—Candelabra (Mazda B) vacuum lamps for multiple circuits.

ally for low voltage and provided with small bases, such as the candelabra or bayonet types. Among these lamps are those for automobile and electric vehicle service. The 110-volt candelabra lamps shown in Fig. 8 are becoming popular for decorative purposes, as, for example, electric candles. Frosted lamps are generally preferred.

The Christmas tree lamps, which were designed originally to eliminate the fire risk in Christmas tree lighting, are now being employed extensively for producing special decorative effects, where the lamps are used as ornaments rather than to produce any considerable illumination. Many special forms of bulbs, such as fruits, flowers, etc., are made. These lamps, which usually operate eight in series on 100 volts, are now made with tungsten rather than carbon filaments.

Important among the battery types of miniature lamps are those for small “flashlights”; while among the recent developments are the miner’s lamps, specified by the U. S. Bureau of Mines.

*Colored Lamps.*—For color matching, photography, theatrical and

decorative purposes, various colored lamps are obtainable. The color is introduced either by means of a dip or by the use of colored glass bulbs. The former is less expensive, but the latter is more permanent. Some of the lamps are special and not usually obtainable on short notice. Bowl-frosted or all-frosted lamps are more

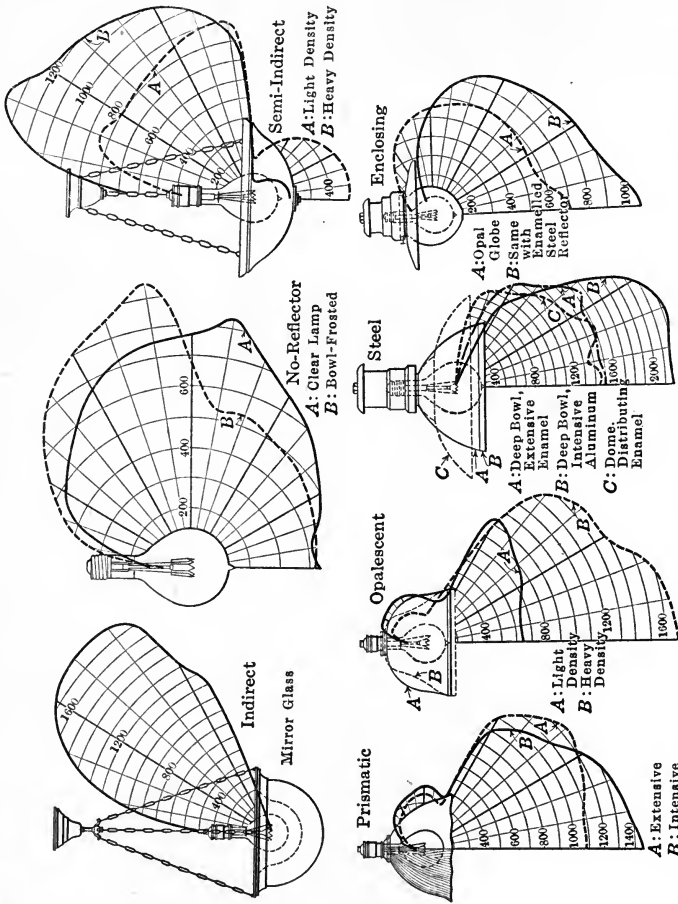

Fig. 9.—Candle-power distribution of typical reflector and globe equipments—500-watt (Mazda C) lamps. (Data furnished by Illum. Eng. Laboratory, Schenectady.)

commonly used in the small sizes. All-frosted lamps are not recommended in the high wattage lamps.

*Complete Equipment.*—The incandescent lamp is not generally to be regarded as a complete lighting unit. For most purposes it is desirable to provide suitable reflectors, shades or globes, for directing and diffusing the light in accordance with particular require-

ments. The most effective illumination is secured when the proper accessory is selected.

Previous to the advent of the high-power lamps, little attention was necessary, from the lamp standpoint, in the design of the fixture, beyond assuring general suitability. Now, however, owing to the large amount of light and heat emitted in a small space, certain precautions are necessary to insure proper performance of lamps.<sup>14</sup> This problem is similar to that encountered with other high-power illuminants. While the majority of fixtures take care of these requirements, there are some fixtures in which suitable provision has not been made.

High-candle-power filaments are too brilliant to be viewed with comfort, and fixtures should have provision for shielding the eyes and diffusing the light, depending upon the application of the equipment.

Ventilation must be provided to carry off the heat and avoid excessive temperature at the top of the lamp. Suitable sockets and leading-in wires should be provided. For high wattage lamps, used out of doors, it is highly important that the fixtures be weatherproof so as to exclude moisture; otherwise during rain and snow storms, water will enter. A drop of water falling on the heated glass, near the top of the lamp, is liable to produce a crack, which will result in failure of the lamp.

Fig. 9 shows the candle-power performance of the 500-watt gas-filled lamp with a few of the most commonly used equipments. For larger or smaller lamps the candle-power can be approximated by proportioning the values to the respective total lumens of the lamps.

#### MOORE COLOR-MATCHING LAMP

The principle of producing light by electrical discharge, through a gas of very low pressure, enclosed in a glass tube, was applied by D. McFarlan Moore. Both long and short tube lamps were developed. The color of the light from such a lamp depends upon the gas used. For example, nitrogen produces a pinkish light, carbon dioxide a white light, neon<sup>17</sup> a reddish light.

The short carbon dioxide tube is the only type in active commercial manufacture in this country at the present time. While this lamp is not widely used it is notable because of the superiority of its light where very accurate color matching is required, as, for example, in dyeing silk, wool, etc. An entirely new form,<sup>16</sup> eliminating

the gas valves and other complicating features, has been developed. This lamp, which is shown in Fig. 10, consumes about 250 watts and operates on alternating-current circuits. While the overall efficiency is relatively low, the light is distributed according to the require-

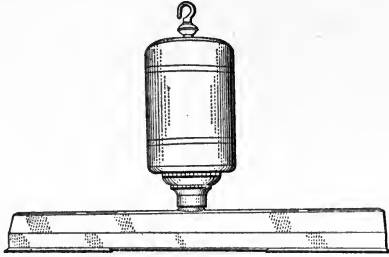

Fig. 10.—Moore color matching lamp.

ments of the accurate color matchers, and intensities up to about 200 foot-candles can be secured over a small area.

#### X-RAY TUBES

Illuminants of this class do not generally interest illuminating engineers directly, though they play an important part in surgery and various physical and chemical researches, in which the peculiar quality of these radiations reveal what cannot otherwise be observed.

The recent development by Dr. Coolidge, which has been characterized as the most important advance since the original discovery, has been summed up as follows:<sup>18</sup>

“Briefly, the device consists of a tube exhausted of all gases to the extreme possible limit, in which is supported the cathode, so arranged that it may be heated electrically; an electrically conducting cylinder or ring connected to the heated cathode, and so located with reference to it as to focus the cathode rays on the target; and the anti-cathode, or target. The advantages of the tube are complete and immediate control, of the intensity and the penetrating power of the Röntgen rays, continuous operation without change in the intensity or character of the rays; absence of fluorescence of the glass; and the realization of homogeneous primary Röntgen rays of any desired penetrating power.”

#### ARC LAMPS

The common forms of arc lamp include the open and enclosed carbon electrode lamp, the open and enclosed flaming carbon electrode lamp and the luminous, magnetite or metallic arc lamps.

The large variety of arc lamps now in active use is indicated by

Fig. 11, which shows the types of electrodes regularly furnished by the National Carbon Company. The engineering data of the principal forms of arc lamps for general lighting service are given in Table III.

*Open and Enclosed Carbon Arc Lamps.*—For general lighting purposes these lamps are generally considered to be superseded, although there are a considerable number still in use, especially for street lighting.

The open arc is the standard illuminant for high power projection lighting,<sup>10</sup> as, for example, with large stereopticons, moving picture machines, and for search lighting and spotlighting. On direct current the brilliant homogeneous crater of the positive is the most effective approximation of the "point source." A heavily impregnated flame carbon electrode is used in the most powerful search-lighting equipments.

Recent developments have done much to increase the effectiveness of the open arc, especially for searchlight work, by surrounding the crater with a cooling atmosphere.<sup>19</sup>

Introduction of chemicals has steadied the arc and the use of small diameter copper or duplex coated negative electrodes has served to reduce electrode shadows.

*Flaming Arc Lamps.*—The flaming arc lamp has the lowest specific consumption of all the common illuminants. It differs from the ordinary carbon arc in that the addition of certain metallic salts changes the process of light production, the light emanating from the arc steam rather than from the craters. The composition of the electrodes determines the color of the light and to a considerable extent the efficiency. Both yellow and white light electrodes are in common use. Red, blue and green electrodes are used for special medical purposes.

Both the open and enclosed (white) flame arcs are used extensively in photo-engraving and other photographic purposes, including moving picture studios, as well as for fading tests of dyes and paints. Some commercial forms for photo-engraving and similar purposes are illustrated in Fig. 12.

The inclined electrode type of lamp, formerly used for spectacular lighting, has in general given way to the enclosed lamp, while the field has extended to street and industrial lighting. White electrodes are usually employed on street and photographic lighting, and yellow electrodes for industrial lighting.<sup>25</sup>

While enclosed flame arc lamps had been produced in 1910, they

did not come into common use in this country until 1911.<sup>20</sup> The early lamps gave an unsteady light, and the solid residue from the electrodes formed an absorbing coating on the enclosing globe. Many improvements have been made in the past few years. Improved condensing chambers have minimized the accumulation on the globes.<sup>21</sup> Probably the greatest recent improvement has been

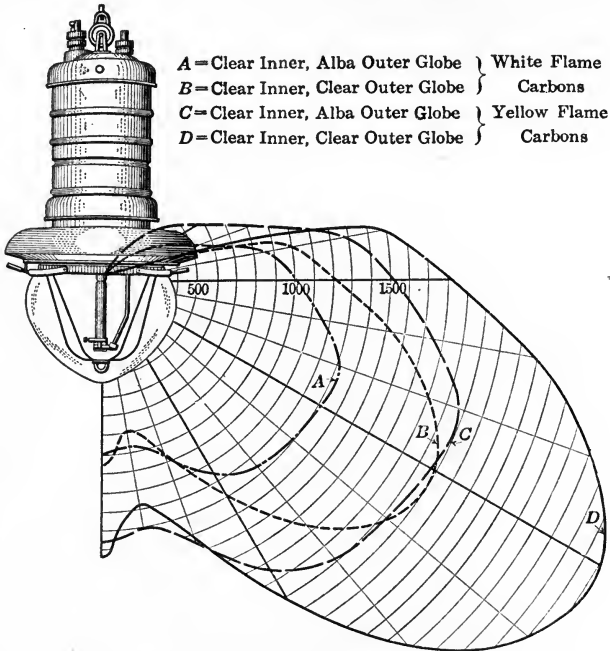

Fig. 13.—Direct current multiple 6.5 ampere 110 volt, enclosed flame arc lamps.  
(Data furnished by Illum. Eng. Laboratory, G. E. Co., Schenectady, N. Y.)

with regard to the composition of electrodes,<sup>23</sup> tending to steady the arc and increase the efficiency. The effectiveness of the photographic arcs has been especially increased.

An ornamental type of enclosed flame lamp for street lighting has been developed and is exploited by a leading manufacturer.<sup>24</sup>

The principal types of enclosed flame arc lamps now on the market for general illumination, are listed below. Their photometric curves are shown in the Figs. 13 to 17 as indicated:

*Luminous, Magnetite, or Metallic Flame Arc Lamp.*—While no radical changes have been made in these lamps since 1910, the efficiency, steadiness and light control have been much improved.<sup>27</sup> An ornamental form has been developed which is receiving quite ex-

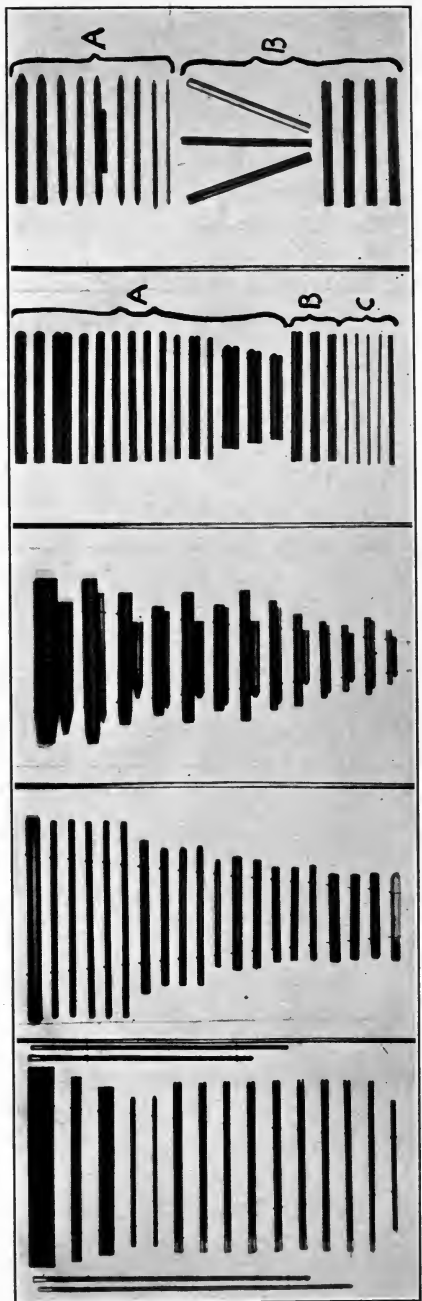

Fig 11.—Types of arc lamp carbon electrodes in common use.  
 (Data furnished by National Carbon Co.)

(Facing page 148.)



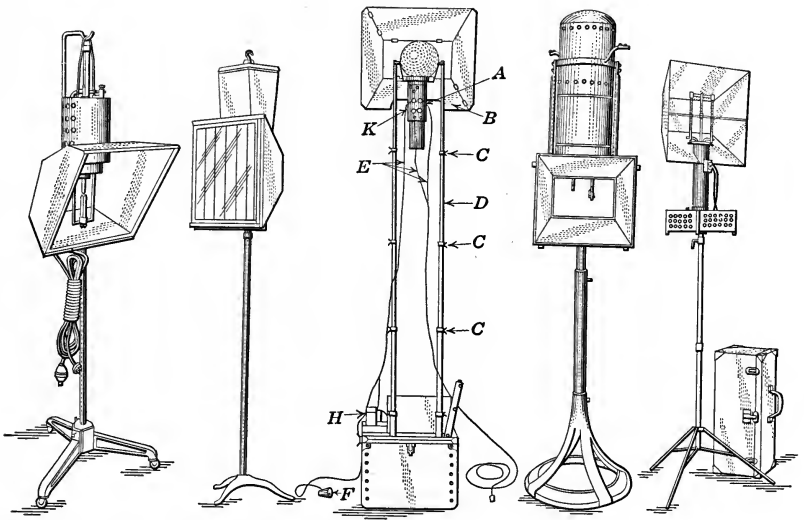

Fig. 12.—Typical open and enclosed flame arc lamps floor types, for photo-engraving and other photographic purposes.

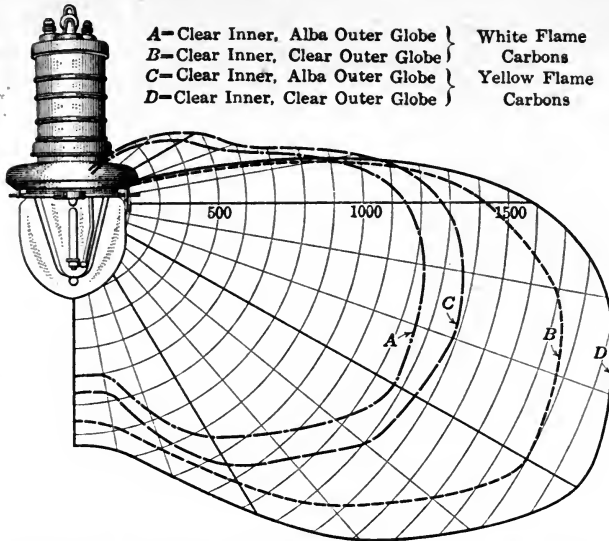

Fig. 14.—Alternating current multiple 7.5 ampere, 110 volt enclosed flame arc lamp. (Internal auto-transformer gives 10.5 amperes at arc).

(Data furnished by Illum. Eng. Laboratory, G. E. Co., Schenectady, N. Y.)

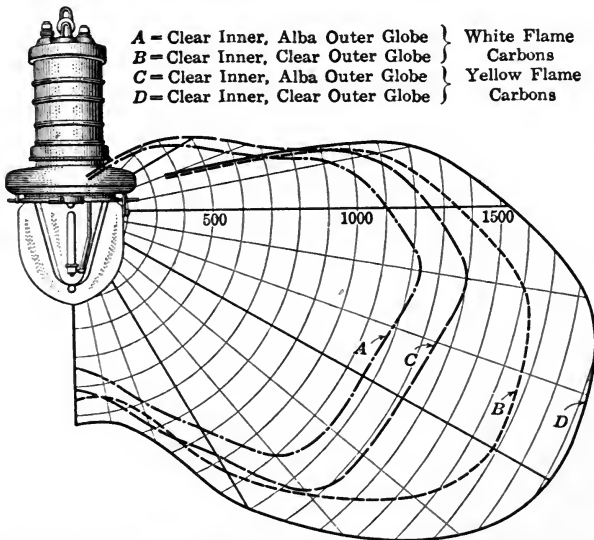

Fig. 15.—Alternating current series 6.6 (or 7.5) ampere enclosed flame arc lamp. (Internal auto-transformer gives 10 amperes at arc.)

(Data furnished by Illum. Eng. Laboratory, G. E. Co., Schenectady, N. Y.)

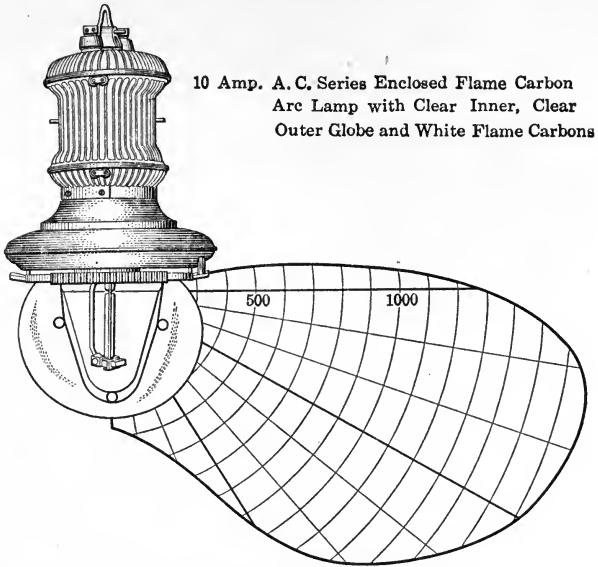

Fig. 16.—Alternating current series enclosed flame arc lamp (9.5 amperes at arc).  
(Data furnished by Westinghouse Elec. & Mfg. Co.)

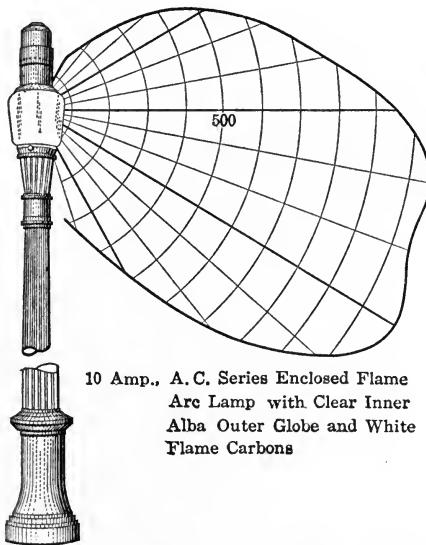

Fig. 17.—Alternating current series ornamental enclosed flame arc lamp.  
(Data furnished by Westinghouse Elec. & Mfg. Co.)

tensive use.<sup>26</sup> Changes in the composition and form of electrodes have been responsible for the increased efficiency and steadiness.

This type of lamp can be operated only on direct-current circuits. The copper or positive electrode consumes slowly by erosion; the negative or magnetite electrode furnishes the arc stream material.

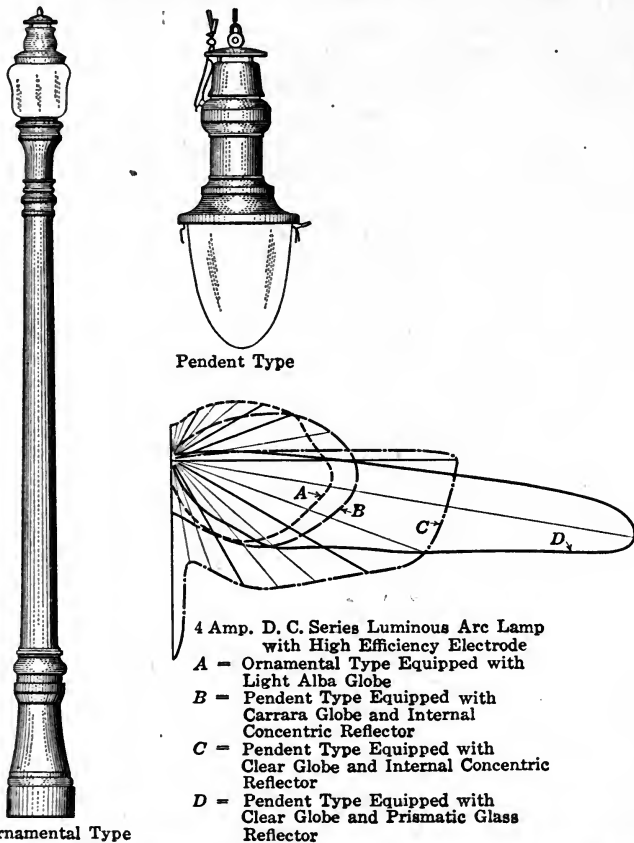

Fig. 18.—Candle-power distribution obtained with different equipments, 4 ampere luminous arc lamp.

(Data furnished by Illum. Eng. Laboratory, G. E. Co., Schenectady, N. Y.)

In the lamp as made by the General Electric Company, a large massive positive electrode (which is not replaced at each trimming) is above the arc. On 4 amperes its operating life is from 6000 to 8000 hours; and on 6.6 amperes from 2000 to 4000 hours.

The magnetite electrodes are made in two types, designated as "long-life" and "high-efficiency." The operating life of the former

is nearly double that of the latter, both varying inversely with the amperage. The high-efficiency type is usually used on 4-ampere lamps, giving about 175 hours; while the long-life type is used on the 6.6 ampere lamp, giving 100 hours or over.

The lamp made by the Westinghouse Electric & Manufacturing Company employs what is known as the "down-draft" principle:<sup>29</sup> A small inexpensive positive electrode is located below the arc and is renewed at each trimming.

While lamps for multiple operation have been made and used for

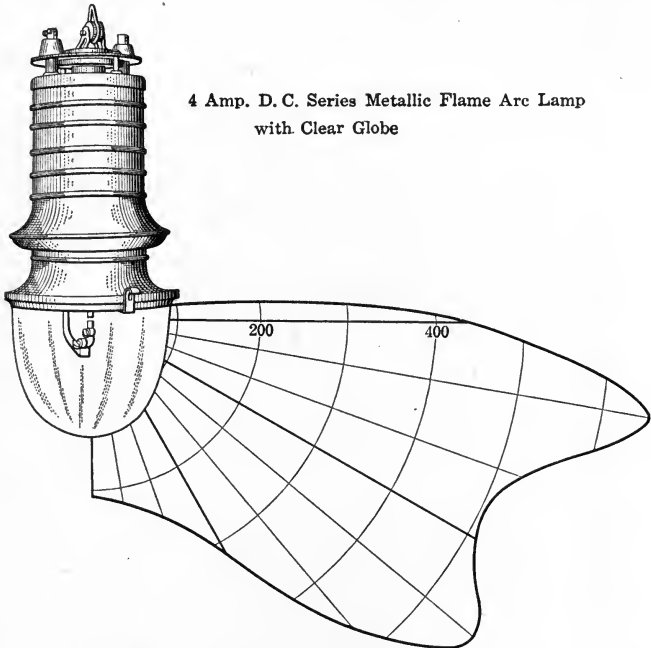

4 Amp. D. C. Series Metallic Flame Arc Lamp  
with Clear Globe

Fig. 19.—Four ampere metallic flame arc lamp.  
(Data furnished by Westinghouse Electric & Mfg. Co.)

industrial lighting, the large amount of ballast resistance necessary to insure steady operation, makes them relatively inefficient and they are no longer exploited. The series lamp, on the other hand, is quite economical, having a low maintenance cost. The light approximates daylight in color and the operation is quite reliable. The series direct current is usually secured from combination constant-current transformers and mercury arc rectifiers, which in turn are supplied with power from alternating-current multiple circuits.

One of the most interesting developments in connection with the

magnetite lamp is the variety of reflectors and of diffusing and refracting globes by which the light distribution is modified to meet the various requirements of street lighting.

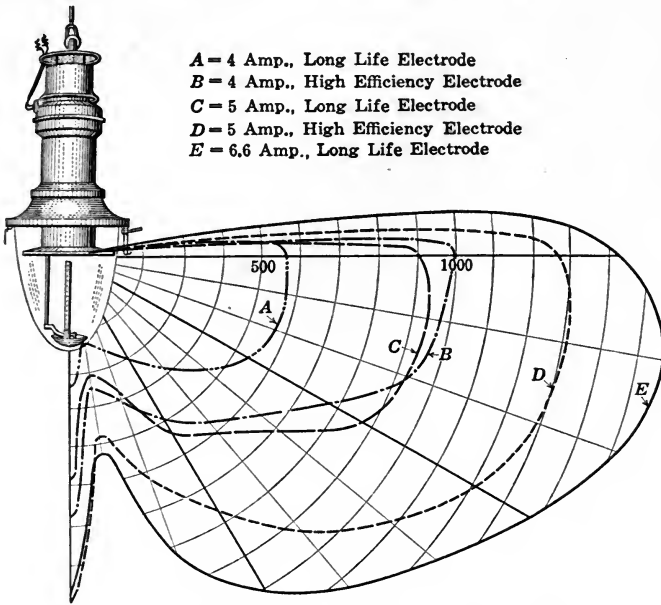

Fig. 20.—Luminous arc lamp, clear globe, concentric reflector.  
 (Data furnished by Illum. Eng. Laboratory, G. E. Co., Schenectady, N. Y.)

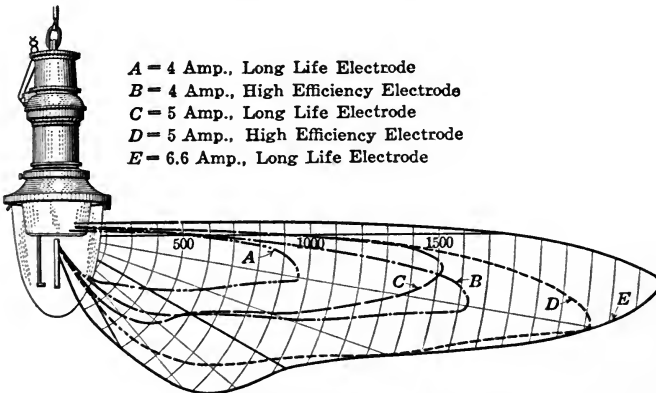

Fig. 21.—Luminous arc lamp, clear globe, refractor.  
 (Data furnished by Illum. Eng. Laboratory, G. E. Co., Schenectady, N. Y.)

The photometric characteristics of the 4-amp. luminous lamps, with the principal types of equipments are shown in Fig. 18. Those

Series arcs	Pendent type	Unit	Electrode	Equipment	Amp.		Volts		Watts		Total lumens	Lumens per watt	Mean hemi-spherical c.p.	Watts per mean hemi-spherical c.p.	Life of electrode in hours	
					Term.	Arc	Term.	Arc	Term.	Arc					Upper	Lower
Enclosed carbon arc lamps																
6.6 Amp. A.C.		Electra	Light opalescent inner, clear outer globe, std street reflector		6.6	6.25	78	73	450	392	1,810	4.03	215	2.07		90
7.5 Amp. A.C.		Electra	Light opal inner, clear outer globe, street reflector		7.5	7.2	76	72	480	460	2,170	4.53	291	1.65		80
6.6 Amp. D.C.		Electra	Light opal inner, clear outer globe, street reflector		6.6	6.5	77.5	75	510	488	3,780	7.42	520	0.98		120
Enclosed flame arc lamps																
6.6 Amp. com-pensator A.C.		White flame	Clear inner, clear outer globe		6.6	10	97.5	47.5	500	437	11,100	22.2	1,430	0.35		130
6.6 Amp. com-pensator A.C.		White flame	Clear inner, alba outer globe		6.6	10	97.5	47.5	500	437	9,940	19.9	1,090	0.46		130
6.6 Amp. com-pensator A.C.		Yellow flame	Clear inner, clear outer globe		6.6	10	97.5	47.5	500	437	12,700	25.4	1,629	0.31		130
6.6 Amp. com-pensator A.C.		Yellow flame	Clear inner, alba outer globe		6.6	10	97.5	47.5	500	437	11,320	22.6	1,244	0.40		130
7.5 Amp. com-pensator A.C.		White flame	Clear inner, clear outer globe		7.5	10	86	47.5	500	437	11,100	22.2	1,430	0.35		130
7.5 Amp. com-pensator A.C.		White flame	Clear inner, alba outer globe		7.5	10	86	47.5	500	437	9,940	19.9	1,090	0.46		130
7.5 Amp. com-pensator A.C.		Yellow flame	Clear inner, clear outer globe		7.5	10	86	47.5	500	437	12,700	25.4	1,629	0.31		130
7.5 Amp. com-pensator A.C.		Yellow flame	Clear inner, alba outer globe		7.5	10	86	47.5	500	437	11,320	22.6	1,244	0.40		130
10 Amp. A.C.*		White flame	Clear inner, clear outer globe		10	9.5	53	47.5	445	405	9,670	21.8	1,400	0.32		130
Luminous arc lamps																
4 Amp. D.C. metallic flame*		Metallic	Clear globe		4	3.95	68	66	272	261	3,142	11.5	495	0.55		250
4 Amp. D.C.		Long life	Carrara globe, internal concentric reflector		4	4	77.5	75.5	310	302	3,100	10.3	311	1.00		4,000
4 Amp. D.C.		Long life	Clear globe, prismatic glass refractor		4	4	77.5	75.5	310	302	3,260	10.5	350	0.69		4,000
4 Amp. D.C.		Long life	Clear globe, internal concentric reflector		4	4	77.5	75.5	310	302	3,020	10.7	479	0.65		4,000
4 Amp. D.C.		High efficiency	Carrara globe, internal concentric reflector		4	4	77.5	75.5	310	302	5,010	16.2	493	0.63		150
4 Amp. D.C.		High efficiency	Clear globe, prismatic glass refractor		4	4	77.5	75.5	310	302	5,030	16.2	698	0.44		150
4 Amp. D.C.		High efficiency	Clear globe, internal concentric reflector		4	4	77.5	75.5	310	302	5,320	17.2	758	0.41		150
5 Amp. D.C.		Long life	Carrara globe, internal concentric reflector		5	5	77.5	75.5	388	378	5,090	13.1	515	0.75		3,000
5 Amp. D.C.		Long life	Clear globe prismatic glass refractor		5	5	77.5	75.5	388	378	5,170	13.3	693	0.50		3,000
5 Amp. D.C.		Long life	Clear globe, internal concentric reflector		5	5	77.5	75.5	388	378	5,130	13.8	770	0.50		3,000
5 Amp. D.C.		High efficiency	Carrara globe, internal concentric reflector (calculated)		5	5	77.5	75.5	388	378	7,260	18.7	737	0.53		120
5 Amp. D.C.		High efficiency	Clear globe, prismatic glass refractor		5	5	77.5	75.5	388	378	7,260	18.7	1,017	0.38		120
5 Amp. D.C.		High efficiency	Clear globe, internal concentric reflector		5	5	77.5	75.5	388	378	7,650	19.7	1,100	0.35		120

\* Furnished by the Westinghouse Electric & Mfg. Co.

Other data furnished by the Illuminating Engineering Laboratory, General Electric Co., Schenectady, N. Y.

Pendent type	Unit	Electrode	Equipment	Amp.		Volts		Watts		Total lumens	Lumens per watt	Mean hemi-spherical c.p.	Watts per mean hemi-spherical c.p.	Life of electrode in hours	
				Term.	Arc	Term.	Arc	Term.	Arc					Upper	Lower
Series arcs															
Luminous arc lamps (Continued)															
6.6 Amp. D.C.	Long life	Carrara globe, internal concentric reflector	6.6	6.6	77.5	75.5	510	498	8,800	17.3	885	0.58	1,500	125	
6.6 Amp. D.C.	Long life	Clear globe, prismatic glass refractor	6.6	6.6	77.5	75.5	510	498	8,960	17.6	1,186	0.43	1,500	125	
6.6 Amp. D.C.	Long life	Clear globe, internal concentric reflector	6.6	6.6	77.5	75.5	510	498	9,300	18.3	1,497	0.39	1,500	125	
Enclosed flame arc lamp															
10 Amp. A.C.*	White flame	Clear inner, alba outer globe	10	9.5	55	48	445	390	8,295	18.6	880	0.50		130	
Luminous arc lamps															
4 Amp. D.C.	Long life	Light density alba globe	4	4	82.5	80.5	330	322	3,220	9.75	271	1.22	7,000	350	
4 Amp. D.C.	High efficiency	Light alba globe	4	4	82.5	80.5	330	322	4,970	15.1	434	0.76	7,000	180	
5 Amp. D.C.	Long life	Light alba globe	5	5	80.5	78.5	403	393	5,020	12.5	429	0.94	4,000	237	
5 Amp. D.C.	High efficiency	Medium density diffusing globe	5	5	80.5	78.5	403	393	7,640	19.0	654	0.62	4,000	137	
6.6 Amp. D.C.	Long life	Medium density diffusing globe	6.6	6.6	80.5	78.5	532	518	9,120	17.1	784	0.68	3,000	112	
Enclosed carbon arc lamps															
3 Amp. D.C.	Electra	Clear inner, clear outer globe, st'd reflector	3	3	220	145	660	435	1,910	2.90	267	2.47		115	
5 Amp. D.C.	Electra	Light opal inner, clear outer globe, st'd reflector	5	5	110	80	550	400	2,438	4.42	342	1.61		140	
6 Amp. D.C. (intensified)	Columbia	Clear inner, bowl frosted outer globe	6	6	110	79	660	474	2,262	3.42	624	1.06		100	
6.5 Amp. D.C.	Electra	Light opal inner, clear outer globe	6.5	6.5	110	80	715	520	4,060	5.67	408	1.75		130	
6 Amp. A.C.	Electra	Opal inner, clear outer globe, st'd reflector	6	6	104	72	400	370	1,380	3.45	177	2.26		115	
7 Amp. A.C. (intensified)	Columbia	Light opal inner globe, alba reflector	7	7	110	75	550	455	1,620	2.95	220	2.50		80	
7.5 Amp. A.C.	Electra	Light opal inner, clear outer globe, st'd reflector	7.5	7.5	104	72	540	477	2,474	4.21	307	1.76		100	
Multiple arcs															
Enclosed flame arc lamps															
6.5 Amp. D.C.	White flame	Clear inner, clear outer globe	6.5	6.5	110	67.5	715	438	12,100	16.9	1,610	0.45		110	
6.5 Amp. D.C.	Yellow flame	Clear inner, alba outer globe	6.5	6.5	110	67.5	715	438	10,320	14.5	1,205	0.50		110	
6.5 Amp. D.C.	Yellow flame	Clear inner, clear outer globe	6.5	6.5	110	67.5	715	438	18,120	25.4	2,406	0.30		110	
6.5 Amp. D.C.	Yellow flame	Clear inner, alba outer globe	6.5	6.5	110	67.5	715	438	15,490	21.7	1,807	0.40		110	
7.5 Amp. A.C.	White flame	Clear inner, clear outer globe	7.5	10.5	110	47.5	540	450	11,300	21.0	1,520	0.36		130	
7.5 Amp. A.C.	White flame	Clear inner, alba outer globe	7.5	10.5	110	47.5	540	450	10,400	19.3	1,120	0.48		130	
7.5 Amp. A.C.	Yellow flame	Clear inner, clear outer globe	7.5	10.5	110	47.5	540	450	12,620	23.4	1,689	0.32		130	
7.5 Amp. A.C.	Yellow flame	Clear inner, alba outer globe	7.5	10.5	110	47.5	540	450	11,180	20.7	1,244	0.43		130	
Luminous arc lamps															
4 Amp. D.C.	Long life	Clear globe, st'd internal concentric reflector	4	4	110	72	440	288	3,193	7.25	463	0.95		350	
6.5 Amp. D.C.	Long life	Clear globe, st'd internal concentric reflector	6.5	6.5	110	72	715	468	8,748	12.2	1,320	0.54		125	

\*Furnished by the Westinghouse Electric & Mfg. Co.  
 Other data furnished by the Illuminating Engineering Laboratory, General Electric Co., Schenectady, N. Y.



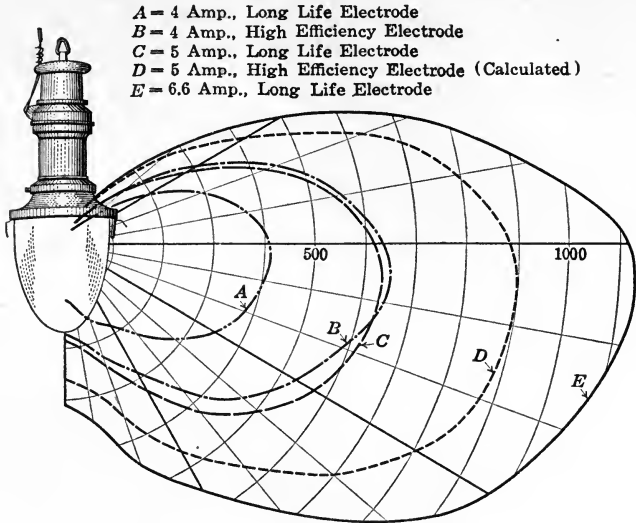

Fig. 22.—Luminous arc lamp, opal globe.

(Data furnished by Illum. Eng. Laboratory, G. E. Co., Schenectady, N. Y.)

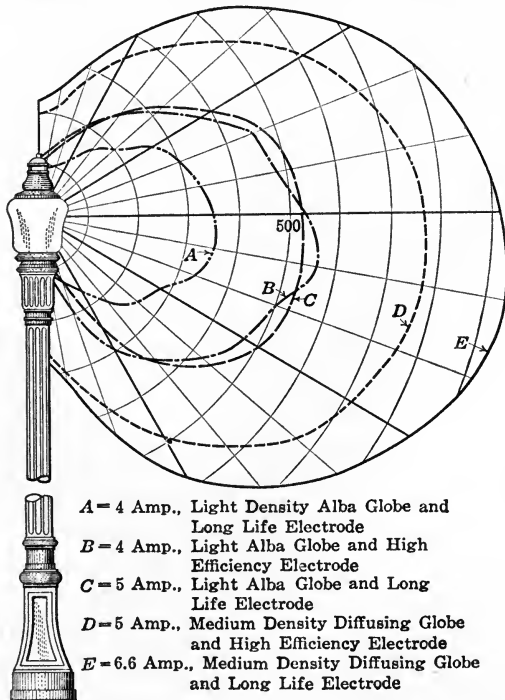

Fig. 23.—Ornamental luminous arc lamp, opal globe.

(Data furnished by Illum. Eng. Laboratory, G. E. Co., Schenectady, N. Y.)

of the 5 and 6.6-amp. lamps correspond approximately in form. The actual candle-power performance of the various standard-equipments is shown in Figs. 19, 20, 21, 22, and 23. These give average initial values taken from several tests on separate lamps and electrodes. For general data see Table III.

The ornamental type of lamp represents one of the important developments, which is receiving wide use in "white way" lighting.<sup>28</sup> It is an inverted lamp only in the sense that the regulating mechanism is located below the arc, so as to be concealed in the pole. Several special types of globes have been furnished to conform with particular artistic requirements. Such equipments have different candle-power characteristics due to variations in shape, light absorption and diffusion.

### MERCURY VAPOR LAMPS

Two principal types of mercury vapor lamps are made in this country; namely, low (vapor) pressure glass tube lamps and high pressure, quartz tube lamps.

*Glass Tube Lamps.*—There has been relatively little change in this type of lamp since 1910. Some improvements have been introduced in the alternating-current lamp, making it a little more efficient and reliable in operation.

A fluorescent reflector<sup>30</sup> has been developed with a view to color correction, supplying some of the missing red rays. While considerable color modification is obtained by this means, it is at some sacrifice in efficiency, and the fluorescent reflector is not used to any considerable extent.

In order to provide a more convenient arrangement for photographic lighting, where a large flood of light is necessary, as in a moving picture studio, special supporting frames have been devised for banking tubes from high power units. These are arranged to project the light in one general direction (Fig. 26).

The usual line of lamps for industrial lighting,<sup>31</sup> is illustrated in Fig. 24, which gives candle-power distribution curves. The curves show the initial candle-power. Fig. 25 shows the variety of standard tubes. The operating life of tubes is stated by the manufacturer as 4000 hours. Published data indicates that the candle-power falls to 80 per cent. of the initial in about 2000 hours. General data are given in Table IV.

TABLE IV.—CANDLE-POWER CHARACTERISTICS OF COOPER HEWITT  
MERCURY VAPOR LAMPS

Lamps for Alternating-current Circuits							
Rating of lamp in average watts	Voltage	Type	Length of tube in inches	Mean lower hemi-spherical c.p.	Watts per mean lower hemi-spherical c.p.	Total lumens	Lumens per watt
210	100-125	E	35	400	0.53	3,179	15.14
380	100-125	F	50	800	0.48	6,283	16.53
For Direct-current Circuits							
	Series on						
192	100-125	H	21	300	0.64	2,388	12.43
385	100-125	HH	21	600	0.64	4,712	12.23
385	100-125	K	45	700	0.55	5,529	14.36
220	100-125	L	35	400	0.55	3,142	14.28
385	100-125	P	50	800	0.48	6,283	16.31
Quartz Lamps for Direct-current Circuits							
726	200-240	Z	4	2400	0.3	18,839	25.96

Data furnished by Cooper Hewitt Electric Co.

*Quartz Tube Mercury Arc.*—The high pressure mercury arc was developed in Europe. Its commercial exploitation in this country, dates from about 1913.<sup>32</sup> The tube is much shorter than that of the low pressure arc and the current density greater. The high temperature of operation necessitates the use of quartz glass as a tube material. Most of its characteristics are similar to those of the low pressure arc, but the appearance of the unit is more like that of a flame arc lamp. In starting, an electro-magnet mechanism tilts the tube to draw the arc. In starting with the lamp cold, about five minutes is required to attain the operating condition. During this period the current and watts are above normal and the candle-power below normal.

Practically all the lamps in use are operated on 220-volt direct current circuits. Lamps for other wattages and alternating current have been made.

The light is essentially similar in color to that of the low pressure mercury arc. Use is made of an outer globe of glass which cuts off

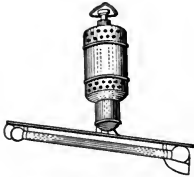

D. C. 55 Volt 3.5 Amp. Two in Series on 100-125 Volt Circuit

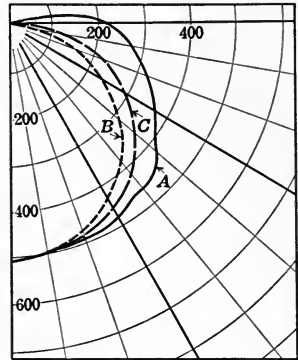

1

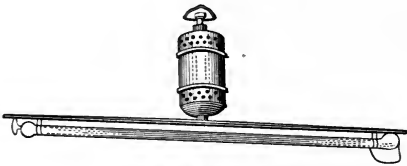

D. C. 100-125 Volt 3.5 Amp.

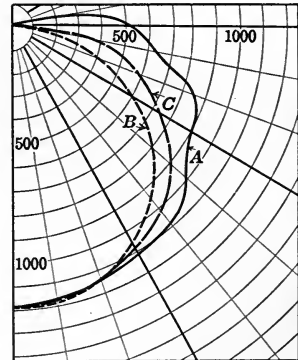

2 & 3

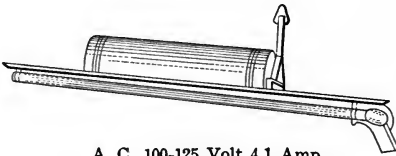

A. C. 100-125 Volt 4.1 Amp.

- Curve *A* Represents the Candle-Power Distribution in a Plane Perpendicular to the Axis of the Tube
- Curve *B* Represents the Candle-Power Distribution in a Plane Parallel to the Axis of the Tube
- Curve *C* Represents the Mean of Curves *A* & *B*

Fig. 24.—Glass tube mercury vapor lamps—Cooper Hewitt.  
(Data furnished by Cooper Hewitt Co.)

(Facing page 158.)

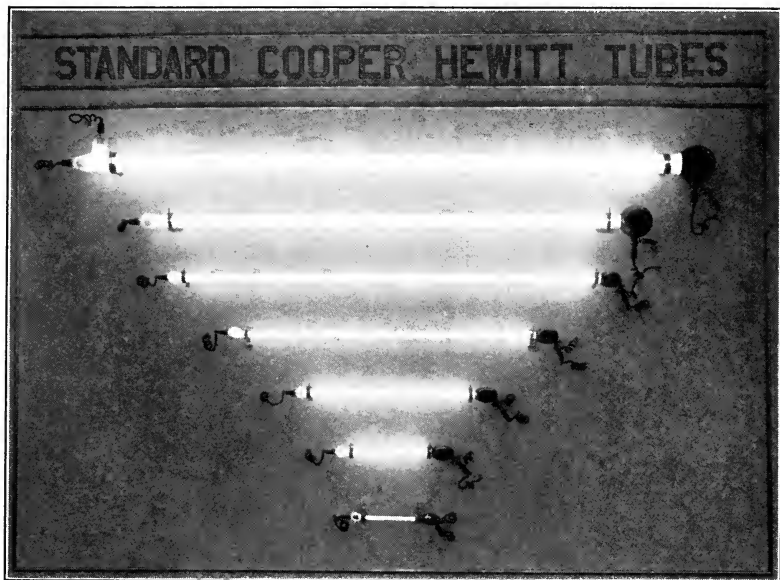

Fig. 25.—Standard tubes now manufactured by Cooper Hewitt El. Co.

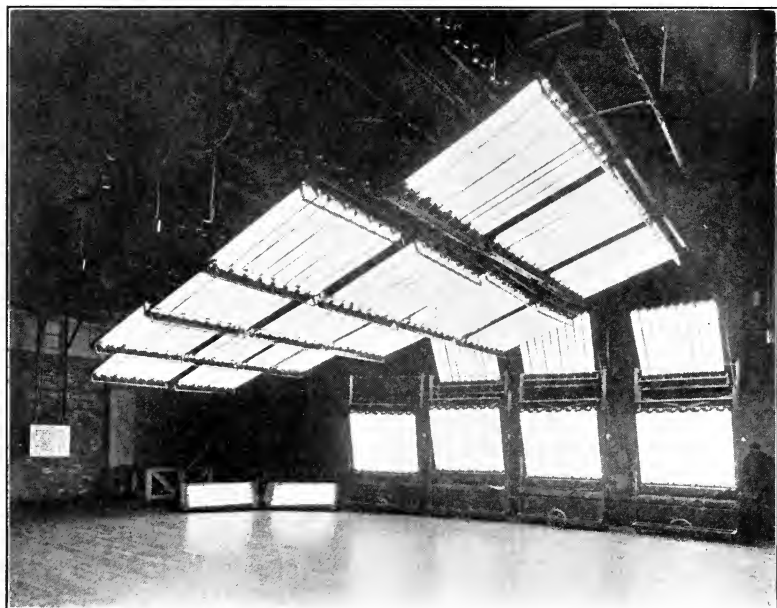
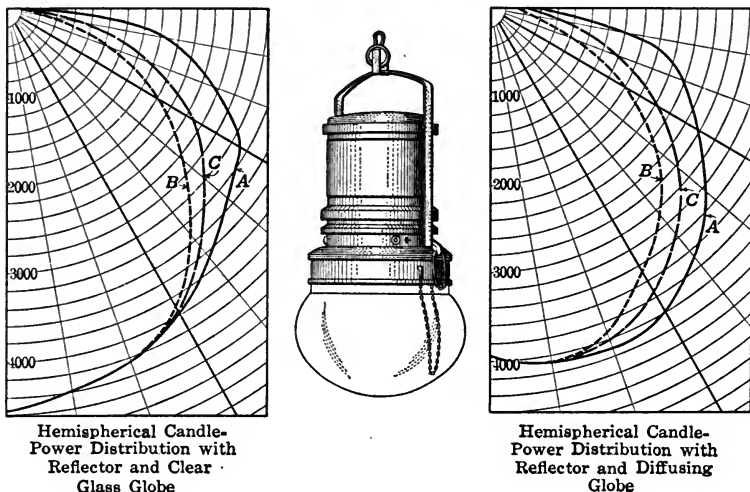

Fig. 26.—Cooper Hewitt mercury vapor lamps banked for moving-picture photography.

the ultra-violet light and tends to diffuse the light. A metal reflector confines practically all the light to the lower hemisphere.

The unit is essentially one of high power, so that in industrial plants it is usually installed where it can be hung 20 ft. or more from the floor.

This lamp is illustrated in Fig. 27, which also shows candle-power distribution, while the general data are given in Table IV.



- Curve *A* Represents the Candle-Power Distribution in a Plane Perpendicular to the Axis of the Burner
- Curve *B* Represents the Candle-Power Distribution in a Plane Parallel to the Axis of the Burner
- Curve *C* Represents the Mean of Curves *A* & *B*

Fig. 27.—Quartz tube mercury vapor lamp—Cooper Hewitt.  
(Data furnished by Cooper Hewitt Co.)

The light from both forms of mercury arc lamp is steady and fairly diffuse. Its most prominent characteristic is its blue-green color, there being no red rays. This precludes its use for decorative lighting, except for special effects. The appearance of faces under the light is not at all pleasing. On the other hand, the light is highly actinic and of such character as to reveal detail to advantage, where visual acuity is an important factor.

The light from the quartz tube lamp (without glass globe) is destructive to certain forms of germ life, and hence, valuable for sterilization.

Both the low-pressure and the high-pressure lamps are used exten-

sively for photographic lighting, for which the actinic of the light renders them quite effective.

These lamps also find considerable application in industrial lighting.<sup>31</sup>

#### CARE OF LAMPS

The performance of any lamp depends upon its receiving a reasonable amount of care. While some types of lamps require more attention than others, no lamp will give its best service if entirely neglected.

The glassware, whether of lamps or windows, will, if allowed to become coated with dirt or dust, absorb an excessive amount of light. The same is true, though usually in a lesser degree, of reflecting surfaces. It is economical to keep globes and reflectors clean, especially those which are so turned as to facilitate the accumulation of dust. Moreover, the good appearance, both lighted and unlighted, often depends very much on cleanliness.

Beside the depreciation due to external accumulation, all illuminants are subject to what is sometimes designated as inherent depreciation; that is, decrease in light due to accumulation or changes inherent in the light source itself. For example, incandescent lamps are subject during their operating life to a gradual decrease in candle-power, due to bulb blackening and the filament shrinking. At the end of the rated life, this depreciation amounts to from 10 to 20 per cent. With nearly all other illuminants the losses are fully as great or greater. With arc lamps losses are principally due to the accumulation of electrode material on the globes. With some arc lamps, the washing of the globe at the time of trimming returns the lamp to initial efficiency, while with others the material fuses into the globes so that it cannot be readily removed. In the case of the incandescent lamp and mercury-vapor lamp, the lamp should be replaced when the loss exceeds certain economic limits, 20 per cent. loss having been generally assumed as the "smashing point" for the incandescent lamp. For arc lamps, the cleaning of the globes at each trimming and the replacing of the globes when badly pitted are the recommended practices.

Unfortunately for best economy the above-mentioned losses accumulate so slowly that their magnitude is not generally recognized, and many lamps are operated at unnecessarily low economies. In a large installation, it is profitable to provide for regular periodic inspection, cleaning and replacement.

In trimming arc lamps it is important to use electrodes of the cor-

rect length and proper diameter, and to make sure that they are in alignment, making good electrical contact with holders.

Mechanisms should be kept clean and in adjustment. Care should be taken on installing to insure that the adjustment is proper for the line current and frequency. Certain forms of arc lamps have suffered more in popularity from careless maintenance than through inherent inferiority.

Incandescent lamps should be specified to correspond to the actual socket voltage (series lamps to amperage). All lamps operate best on steady voltage. Excessive change in voltage means unsteadiness of light, and in some cases objectionable jumping and flickering.

### SELECTION OF LAMPS

For most classes of lighting, practice has indicated some one type of lamp which is better suited than others, so that there is not so keen a competition between types as formerly. The problem now is more the selection of lamps of proper power. This subject is so broad and involves spacing and height, as well as candle-power distribution characteristics to such an extent as to render a full discussion at this point impracticable. It does seem desirable, however, to warn against giving too much weight to abstract comparisons of candle-power or lumen output, or efficiency, or even of operating cost, especially where the differentials are relatively small.

Reliable and accurate comparisons can only be made by taking into account many factors with reference to the conditions to be met in installation. It often happens that the higher efficiency of a high power lamp is counteracted by waste of light, or objectionable shadows, accompanying wide spacing. Again, an efficient lamp may have a high investment or maintenance cost.

Cost comparisons are of value and should be made where large numbers of lamps are involved. Such an estimate should include the following items:

1. Cost of energy.
2. Material of maintenance.
3. Labor of maintenance.
4. Depreciation (which will refund the investment when the lamps are worn out or become obsolete, but not include material of maintenance).
5. Interest on investment (including installation cost).
6. Any other overhead charges, such as insurance.

On the other hand, there are important factors which do not lend themselves to expression in figures.



The following are some of the desirable qualities which should be considered in lamp selection:<sup>33</sup>

(a) Intensity or light flux—suited for condition, allowance being made for depreciation.

(b) Diffusion—of a degree depending upon requirements.

(c) Distribution characteristic—such as to insure economical utilization.

(d) Color—to meet the demands of utility and pleasing appearance.

(e) Steadiness—slight animation not being necessarily objectionable; perceptible flicker almost invariably objectionable.

(f) Reliability—insuring continuity of illumination, also safety.

(g) Economy—as previously noted, should be judged by concrete rather than abstract estimate of costs.

(h) Artistic features—involves the appearance of lamp fixtures, lighted and unlighted, as well as the lighting effect itself. Deserves more attention in ordinary installations than it usually receives.

(j) Adaptability—this is important in large installations where it is desirable to meet a variety of conditions with a minimum number of types and renewal parts to be kept in stock.

(k) Construction—quality. Practically all the established illuminants are well made. For severe service, special constructions are sometimes necessary.

(l) Convenience—ease of handling by unskilled persons.

(m) Congruity. This applies to the general suitability of the illuminant to its surroundings.

While no accurate method of applying these considerations is here suggested, a common-sense consideration of these points will facilitate forming a true evaluation of a lighting unit for particular service.

### CONCLUSION

Much of the foregoing is necessarily suggestive, but definite information is given where practicable. It must be remembered that, with the rapid advance in the art of lamp manufacture, the performance of illuminants is likely to be bettered in the near future.

In conclusion, the writer desires to express appreciation for the data and information furnished by lamp and electrode manufacturers.

### References

<sup>1</sup> C. P. STEINMETZ.—“Electric Illuminants.” Lectures on Illuminating Engineering, Johns Hopkins University, 1910, page 109.

<sup>2</sup> E. P. HYDE.—“The Physical Characteristics of Light Sources.” Lectures on Illuminating Engineering, Johns Hopkins University, 1910, page 25.

<sup>3</sup> W. R. WHITNEY.—“The Chemistry of Luminous Sources.” Lectures on Illuminating Engineering, Johns Hopkins University, 1910, page 93.

<sup>4</sup> W. F. LITTLE.—“Lighting Accessories” (See lecture in this series).

<sup>5</sup> F. W. SMITH, Chairman, Lamp Committee N. E. L. A.—“Report of Lamp Committee.” Proceedings of National Elec. Light Assn., 1916.

<sup>6</sup> C. G. FINK.—“Ductile Tungsten and Molybdenum.” Trans. American Electro-Chemical Society, Vol. XVII (1910), page 229. General Electric Review, Vol. XII (1910) page 323.

<sup>7</sup> W. D. COOLIDGE.—“Wrought Tungsten.” Trans. American Inst. of Electrical Engineers. Vol. XXIX (1910), page 961.

<sup>8</sup> J. W. HOWELL.—“The Manufacture of Drawn Wire Tungsten Lamps.” G. E. Review, Vol. XVII (1914), page 276.

<sup>9</sup> WARD HARRISON and E. J. EDWARDS.—“Recent Improvements in Incandescent Lamp Manufacture.” Trans. Ill. Eng. Society. Vol. VIII (1913), page 533.

<sup>10</sup> E. J. EDWARDS and H. H. MAGDSICK.—“Light Projection” (See lecture in this series).

<sup>11</sup> IRVING LANGMUIR.—“The Blackening of Tungsten Lamps and Methods of Preventing It.” Trans. American Inst. of Electrical Engrs., Vol. XXXII (1913), page 1913.

<sup>12</sup> IRVING LANGMUIR and J. A. ORANGE.—“Nitrogen Filled Lamps.” Trans. Amer. Inst. of Elect. Engrs., Vol. XXXII (1913), page 1935.

<sup>13</sup> G. M. J. MACKAY.—“The Characteristics of Gas-filled Lamps.” Trans. Ill. Eng. Society, Vol. IX (1914), page 775.

<sup>14</sup> F. W. SMITH (Chairman, Lamp Committee N. E. L. A.).—“Report of Lamp Committee.” Proceedings National Elec. Light Assn., 1915.

G. F. MORRISON.—Review of Lamp Committee Report. G. E. Review, Vol. XVIII (1915), page 925.

<sup>15</sup> D. B. RUSHMORE.—“Frequency.” Trans. American Inst. of Electrical Engrs., Vol. XXXI (1912), pages 970 and 978.

<sup>16</sup> D. MCFARLAN MOORE.—“Gaseous Conductor Lamps for Color Matching.” Trans. Ill. Eng. Society, Vol. XI (1916), page 162.

<sup>17</sup> GEORGES CLAUDE.—“Neon Tube Lighting.” Trans. Ill. Eng. Society, Vol. VIII (1913), page 371.

<sup>18</sup> W. D. COOLIDGE.—“A Powerful Röntgen Ray Tube with Pure Electron Discharge.” Physical Review, Dec., 1913. G. E. Review, Vol. XVII (1914), page 104.

<sup>19</sup> C. S. McDOWELL.—“Illumination in the Navy.” Trans. Ill. Eng. Society, Vol. XI (1916), page 574.

<sup>20</sup> S. H. BLAKE.—“Flame Arc Lamps.” G. E. Review, Vol. XIV (1911), page 595.

<sup>21</sup> G. N. CHAMBERLIN.—“Enclosed Flame Arc Lamp.” G. E. Review, Vol. XV (1912), page 706.

<sup>22</sup> R. B. CHILLAS.—“The Development of the Flame Carbon.” Trans. Ill. Eng. Society, Vol. IX (1914), page 710.

<sup>23</sup> V. A. CLARK.—“Present Status of Arc Lamp Carbons.” Electrical Review and Western Electrician, Vol. LXVII (1915), page 406.

<sup>24</sup> C. E. STEPHENS.—“Modern Arc Lamps.” Electrical Review and Western Electrician, Vol. LXVII (1915), page 409.

<sup>25</sup> A. T. BALDWIN.—“The Flaming Arc in the Iron and Steel Industry.” Proceedings Assn. Iron & Steel Elect. Engrs. (1914), page 491.

<sup>26</sup> C. A. B. HELVORSON, JR.—“New Types of Ornamental Luminous Arc Lamps.” G. E. Review, Vol. XV (1912), page 710.

<sup>27</sup> C. A. B. HALVORSON, JR.—“Improvements in the Magnetite Lamp.” G. E. Review, Vol. XVII (1914), page 283.

<sup>28</sup> C. A. B. HALVORSON, S. C. ROGERS and R. B. HUSSEY.—“Arc Lamps for Street Lighting.” Trans. Ill. Eng. Society, Vol. XI (1916), page 251.

<sup>29</sup> F. CONRAD and W. A. DARRAH.—“The History of the Arc Lamp.” Electric Journal, 1916, pages 103 and 140.

<sup>30</sup> H. E. IVES.—“Study of the Light from the Mercury Arc.” Electrical World, Vol. LX (1912), page 304.

<sup>31</sup> W. A. D. EVANS.—“Industrial Lighting with Mercury Vapor Lamps.” Trans. Ill. Eng. Society, Vol. X (1915), page 883.

<sup>32</sup> W. A. D. EVANS.—“The Mercury Vapor Quartz Lamp.” Trans. Ill. Eng. Society, Vol. IX (1914), page 1.

<sup>33</sup> P. S. MILLAR.—“The Status of the Lighting Art.” Trans. Ill. Eng. Society, Vol. VIII (1913), page 652 (See “Categories of Illumination,” page 654).

## RECENT DEVELOPMENTS IN GAS LIGHTING

BY ROBERT FRENCH PIERCE

For the purpose of this lecture the term "recent developments," will be applied to changes and improvements in gas lighting appliances effected and reduced to commercial practice since 1910, progress prior to that year having been set forth in the lectures at Johns Hopkins University.

The economic position of the gas industry has tended to restrict development to the refinement and elaboration of existing types rather than to encourage increasing diversity in the application of gas to lighting.

Gas was the first central station illuminant and until 1880 the only one. At the present time, in the older communities of the East there are from four to seven times as many gas meters as electric meters in use, while even in the newer communities of the West, where cheap hydro-electric power and dear coal place the gas industry under a severe handicap, the number of gas meters usually exceeds that of electric meters in use. Following the line of least resistance the gas industry has directed such of its energies as have been devoted to lighting toward those improvements which would best protect its existing lighting business, while the commercial exigencies of electrical development have favored the creation of new uses and excursions into new fields.

During the past five years the principal developments in gas lighting have had for their objects increased economy in light production through more efficient utilization of the gas and decreased maintenance expense, and the elimination of inconvenience in the use and maintenance of gas lighting units, with the purpose of forestalling, overcoming or reducing the users' inclination toward providing facilities for the use of competing illuminants.

The gas lamp is composed of two essential parts—the burner and the mantle, the former usually being fitted with a glass chimney to secure satisfactory and efficient operation.

Possibilities of increased economy of light production lie in obtaining higher temperatures through improved burner design; in

securing a larger proportion of luminous radiation through the selection of mantle materials having a more favorable selective radiation characteristics; in prolonging the useful life of the mantle by the utilization of less fragile base fabrics; and in eliminating such accessories as chimneys the maintenance of which is an item of expense.

Opportunities for securing added convenience in the use of gas lamps lie in such of the above developments as reduce the number of parts requiring attention and the frequency with which essential parts need replacement, and in the provision of simple, inexpensive and reliable means of ignition and distance control.

### THE MANTLE

The physical character of the mantle is determined by the two essential substances which enter into its manufacture, (1) the organic fabric which is impregnated with solutions of salts of the (2) rare earths (ceria and thoria) that form the ultimate mantle structure, the organic matter being burned out in the process of manufacture. The character of the fabric used determines the mechanical strength of the mantle, its shrinkage under the continued heat of the flame, and to a small extent the luminosity of the mantle. The rare earths employed determine the radiant efficiency of the mantle, and the color of the light emitted.

No significant change in the proportions of ceria and thoria employed has taken place in the past twenty years, and although a theoretical consideration of the physics of rare earths radiation indicates the possibility of greatly increased efficiency through the employment of hitherto unused elements, no promising experimental results have as yet been recorded.

The utilization of "artificial silk" as a base fabric was noted by Whittaker in his Johns Hopkins lecture, but this material had not at that time been brought to such a commercial stage as would warrant specific quantitative statements as to its performance, and the employment of this substance may for the purposes of this lecture be regarded as a subsequent development. Mantles made upon this base have been used in large quantities during the past three years and exhibit a great superiority over previous types in tensile strength, flexibility, permanence of form and maintenance of luminosity. The artificial silk mantle of the upright type after several hundred hours service will support a suspended weight of



Fig. 1.—Demonstrating tensile strength of artificial silk mantle *after burning*.



Figs. 2a and 2b.—Demonstrating flexibility and resiliency of artificial silk mantle, *after burning*.

(Facing page 166.)

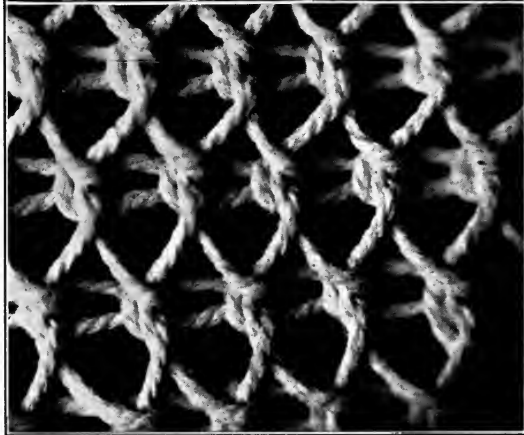

Fig. 3.—Cotton mantle fabric, after burning.

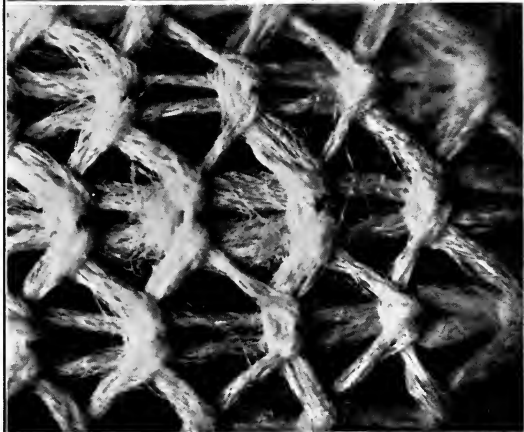

Fig. 4.—Ramie mantle fabric, after burning.

(Highly magnified.)

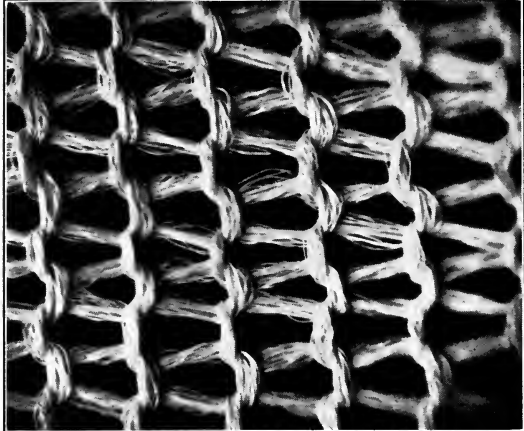

Fig. 5.—Artificial silk mantle fabric, after burning.

one ounce, may *with care* and skill be folded and crumpled upon itself and restored to its original form without apparent damage and will maintain its initial candle-power practically unimpaired for an indefinite period—5000 hours actual service producing a depreciation of less than 10 per cent. These facts while exemplifying no practical condition, are highly significant as indicating most desirable and important physical properties. It should be understood, of course, that the rather theatrical demonstrations of desirable physical qualities referred to are not to be attempted by the user unless he wishes to purchase a new mantle.

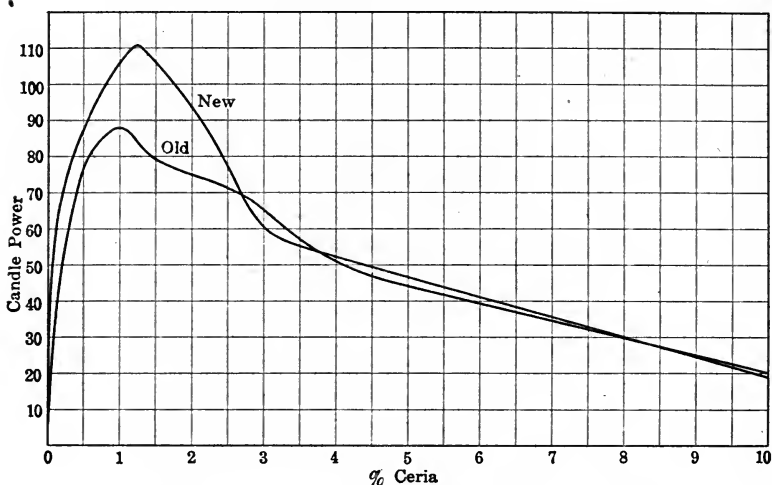

Fig. 6.—Influence of ceria content on candle-power of mantle.

The desirable qualities of artificial silk are due to the fact that the fibers are *solid* and continuous, instead of cellular and comparatively short.

Figs. 3, 4 and 5 showing magnified sections of different mantle fabrics illustrate the steel-cable-like structure of the artificial silk mantles compared to that of mantles based upon vegetable fibers more resembling a hempen rope. The cellular structure is largely responsible for the shrinkage during burning which characterizes cotton mantles.

Due to causes not altogether apparent the luminosity of a mantle is considerably influenced by proportioning of the rare earth contents with relation to the physical structure of the mantle fabric, and refinements in manufacturing processes have resulted not only in



increasing efficiencies with the same fabrics, but in altering the relation between ceria content and luminosity. Fig. 6 shows two curves of mantles, made upon the same fabric, the one designated "old" being that reproduced by Whittaker in the Johns Hopkins lectures. Since the yellowness of the light emitted varies with the ceria content, it is apparent that the later mantles appreciably widen the range of color-values which may be economically obtained in the gas mantle.

Other interesting developments involving departures from previous methods of mantle construction have occurred, but, since they are more directly related to modifications in the burner, they will be introduced later.

### BURNERS

Since the efficiency of an incandescent gas lamp is directly related to the flame temperature, and the latter depends largely upon the proportion of primary air entrained, it is desirable that the latter be as large as practicable. But since the speed of flame propagation is also increased with the proportion of primary air, the latter is practically limited by the velocity of the outflowing mixture at the nozzle, because the speed of flame propagation and velocity of outflow must be equal in order to avoid "flashing back" of the flame on the one hand, or, "blowing off" on the other—the latter difficulty, however, never being experienced at ordinary pressures.

The highest velocity of outflow is secured by means of proper design of the bunsen tube and freedom from bends or obstructions in the burner. Such a burner, however, fails to secure thorough mixture of the gas and air with the result that the more highly aerated "streaks" permit the flashing back of the flame even though the average speed of flame propagation is far below that in the more highly aerated portions. Since thorough mixture of the gas with the entrained air involves some loss in the velocity of outflow, burner design is resolved into the elimination of all obstructing and retarding influences except those required for mixing the gas and air in the most efficient manner.

The sole source of energy for the entrainment of air, mixing it with the gas and the propulsion of the mixture into the flame is the kinetic energy of the gas issuing from the orifice under a pressure of (ordinarily) less than 2 ounces per square inch, and it is the conservation of this small amount of energy that presents the greatest problem to the designer of incandescent gas lamps.

Within the last three years a greater appreciation of the importance of this feature has led to the development of a type of burner having not only improved efficiency, but simpler construction and fewer parts than have characterized previous types. These results are direct consequences of greater air entrainment, more thorough mixing of the gas and air, and higher nozzle velocities. In the previous types larger proportions of secondary air were required. To bring this secondary air into the flame with sufficient speed to localize the combustion area most effectively in the mantle surface and secure satisfactory efficiencies, various devices were employed—notably air-hole cylinders and “stacks” to produce strong upward drafts. These accessories complicated design, increased maintenance expense and often interfered with adaptation of the lamps in fixture design. In the recent lamps it has been found practical to eliminate chimneys, lamp housings, stacks, etc., with no loss of efficiency. The elimination of the chimney or cylinder removes one of the most troublesome sources of candle-power depreciation in gas lamps. Reduction of illumination of from 10 to 20 per cent. in 1000 hours' active service commonly results from the dust deposits on chimneys.

Relieved from the necessity of accommodating these accessories, the designer has employed greater freedom in the development of a range of sizes, and in their application and these lamps are now made in sizes from one to six mantles and in upright, inverted and horizontal forms. The mantle generally used with these burners is  $1\frac{1}{8}$  in. in diameter by  $1\frac{1}{4}$  in. long, mounted on the common open top ring. It has been found however that with this type of burner closed top mantles  $\frac{5}{8} \times 1$  in., consuming about 1 cu. ft. of gas per hour may be used, there being no necessity for leaving a space at the top of the mantle for the egress of combustion products in excess of those which pass through the mantle mesh. This permits the use of the so-called rag or soft mantle—a mantle from which the organic fabric has not been burned out, this operation, which is usually performed in the factory, being done by the purchaser. In order for the mantle to fill out properly an appreciable pressure inside the mantle is necessary. This is obtained by the use of compressed air at the factory, but on the customers' premises only the ordinary pressure within the mantle is available, and in order for this to be effective, the top of the mantle must be closed, forcing all the products through the meshes of the fabric. With the existing pressures on the customers premises, it is not practicable to

burn off and properly harden a mantle larger than  $\frac{5}{8} \times 1$  in. on the customers' burners.

The rag mantle has many advantages. It is as soft and pliable as any other knitted fabric. It cannot be injured by handling and may be packed in a small space and transported with impunity. The lamp shown in Figs. 7 and 8 is equipped with three of these small size rag mantles and is particularly adapted to fixtures with upright outlets, as for example, those ordinarily fitted with open flame tips.

The inverted lamp (that is, that in which the bunsen type projects downward from the gas orifice) requires a housing of some sort to which the shade may be attached and in which means for conducting the combustion products away from the air ports may be provided.

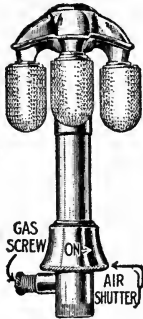

Fig. 7.—New upright burner with inverted mantles. (Cut about one-third actual size.)

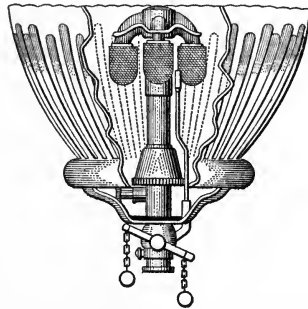

Fig. 8.—Installation of lamp shown in Fig. 7.

Until recently, the discoloration of the lamp housing and supporting fixture arm or pendant by heat and combustion products was a serious drawback in the use of inverted gas lamps, particularly in residences and in mercantile establishments of the better class. In the latest designs this trouble has been eliminated by providing an air space between on the inner and the outer shell, and a deflector which ejects the combustion products with sufficient velocity to carry them several inches out from the top of the lamp. Figs. 9*a* and 9*b* show distributions of temperatures about two lamps of this type, the center of the uprising column of products being shown by the heavy line connecting the points of maximum temperature at each level. Protracted tests indicate that the elimination of fixture discoloration by this method is complete.

An interesting development in the design of inverted burners is

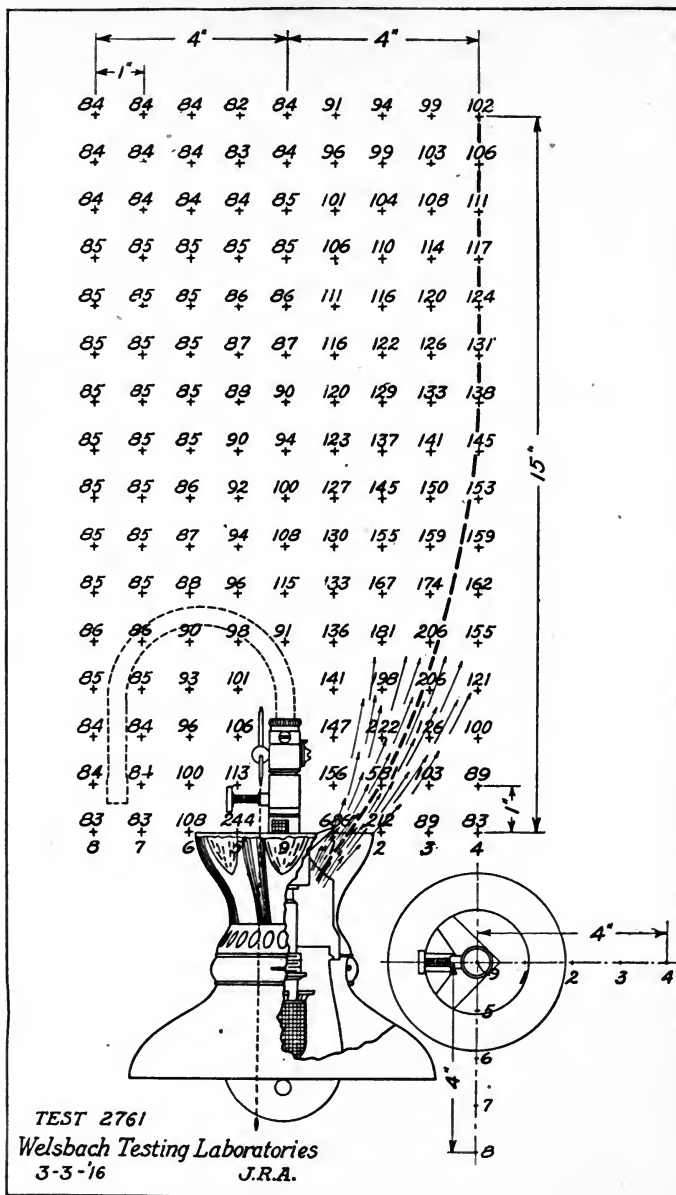

Fig. 9a.—Distribution of temperature about side-vent lamp consuming  $2\frac{3}{4}$  cubic feet of gas per hour.

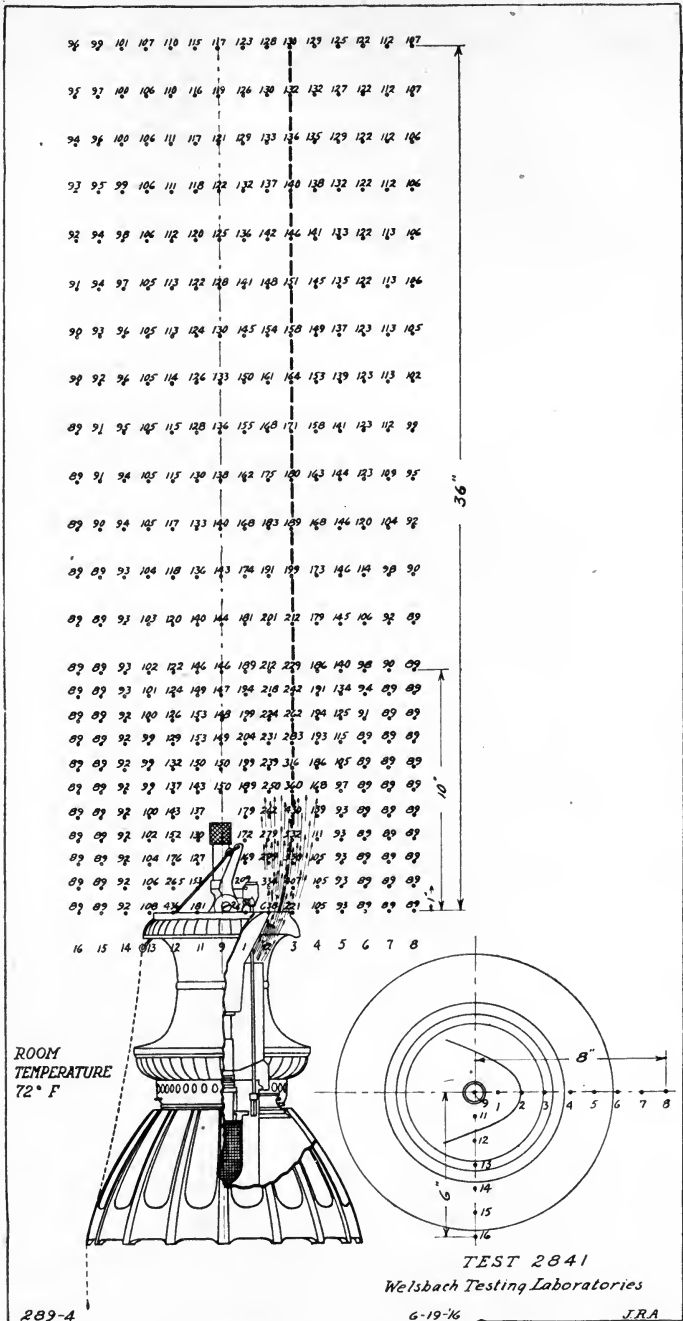

Fig. 9b.—Distribution of temperature about side-vent lamp consuming 9½ cubic feet of gas per hour.

shown in Fig. 10. In this design both the air intakes and the vents are concealed from ordinary view, and the parts are so arranged as to permit the design of a burner exterior of unobtrusive form and attractive lines. This design has been applied to sizes ranging from 85 to 250 candle-power, and thus accomplishes a standardization of appearance approaching that obtained by means of the standardized socket construction in incandescent electric lamps. The gas cock is operated by a single pull chain, and the complete unit possesses many features which appeal to the fixture designer as well as to the customer who wishes to avoid the use of lamps which too strongly announce by their appearance the nature of the illuminant supplied to them.

These lamps together with the small upright lamp shown in Fig. 7 comprise the leading products of the most important American manufacturers of gas lamps, and it is interesting to note that in both types the tendency has been to eliminate features which emphasize to the eye the burner itself.

#### IGNITION

During the past five years several means of ignition have been attempted, the most general being electrical—in the form of either a jump spark or an electrically heated platinum wire. The accessory apparatus required—dry batteries, accumulators, etc., and the comparatively high cost of the ignition devices, have limited the application of even the most satisfactory of electrical systems to special conditions in which ignition of this character is particularly desirable. For several years the jump-spark system of ignition has been utilized for gas ignition. This system usually consists of a dry battery, induction coil and spark gaps, one for each lamp, arranged in series. The drawbacks to this system have been the difficulty of securing proper insulation for the secondary or high-tension circuit, the high first cost of the installation, and the necessity for providing a separate system for distant control when the latter is required—which is usually the case. A recent development, originating in and at present confined to Germany, but of sufficient interest to warrant description here, involves the use of a special form of switch which, when operated, sets in motion a vibrating contractor in the primary circuit, the vibrations persisting for a period sufficient to permit the gas, which is turned in by a magnet valve in the same circuit, to reach the lamp before the high-tension spark induced by the making and breaking of the primary circuit,

dies out. The induction coil is placed in a canopy above the lamp which also contains the magnet valve. In this system the high-tension circuit is confined to the lamp fixture. This device is absolutely positive and reliable in action, its only drawback being the high cost, a separate induction coil and magnet valve being required for each fixture (see Figs. 11 and 12).

Many attempts have been made to utilize the catalytic action of platinum for gas ignition. In the finely divided form known as platinum black this element possesses the property of condensing oxygen upon its surface and initiating combination with hydrogen in the presence of the latter. The self-lighting mantles which sporadically appear upon the market rely upon a "pill" of platinum black upon the mantle surface to secure ignition. The catalytic action is, however, so rapidly decreased by the agglomeration of the particles of heat and other unavoidable influences, and the consequent reduction of catalyzing surface presented, that this expedient has never come into extended commercial application.

It has been found, however, that platinum wire heated to about 500°C. is capable of initiating the combination of hydrogen and oxygen and this fact has been utilized in the "hot-wire" ignition system (Fig. 13), in which electric current from a small dry battery or accumulator provides the heating energy. When this system was first applied a dry battery was placed in the shell, a switch being actuated by the operation of turning the gas cock. As long as the battery voltage is regulated within narrow limits the results are very satisfactory. A device of similar principle in which the heated platinum filament is used to ignite a pilot flame which in turn ignites the gas at the lamp burner, has been on the market for sometime but apparently without radically affecting the current practice in gas ignition, which is by means of a continuously burning pilot flame.

The pilot-flame method is too commonly used and known to require explanation. The greatest drawbacks of the earlier and in fact all but the most recent types were the cost of the gas consumed, which, though negligible in a frequently used installation, is comparatively great in the case of lamps in active service for only a few hours per week; and the liability to outage from draughts, deposits of pipe-scale, tar, etc. In well-operated gas works the gas is freed from the tar at the works. Where practice is poor in this particular a small filter-box is placed in the gas supply to the pilot. The asbestos packing in this filter-box which retains dust, scale, tar, etc., and can easily be removed and renewed when fouled.



Fig. 10.—Recent types of inverted lamps.

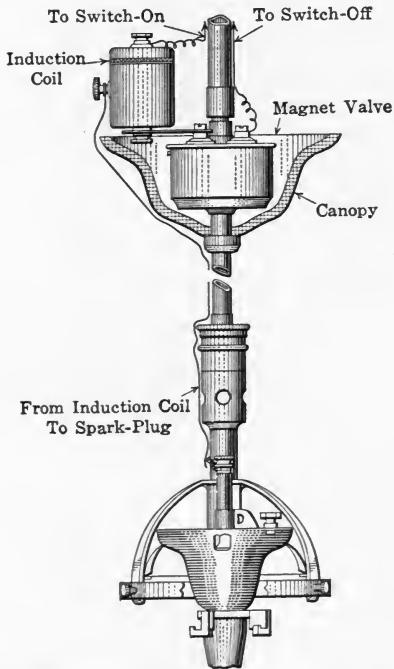

Fig. 11.—Installation of magnet-valve and induction coil for distant control and jump-spark ignition.

(Facing page 174.)



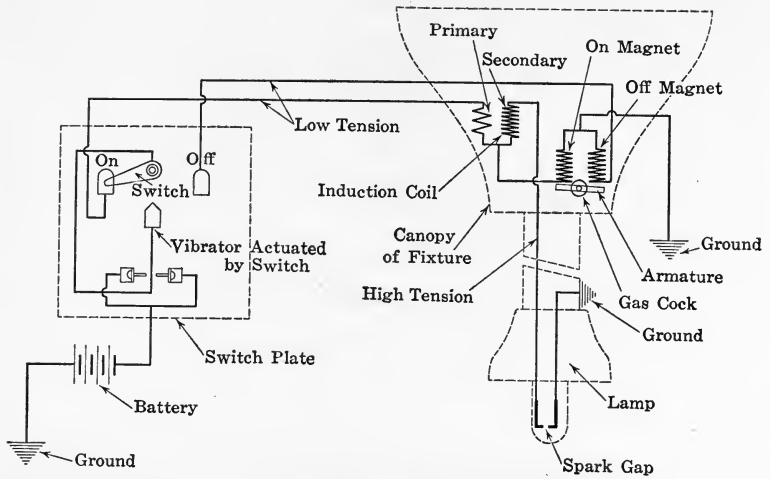

Fig. 12.—Wiring connections for electro-magnetic distance control and ignition of gas lamps.

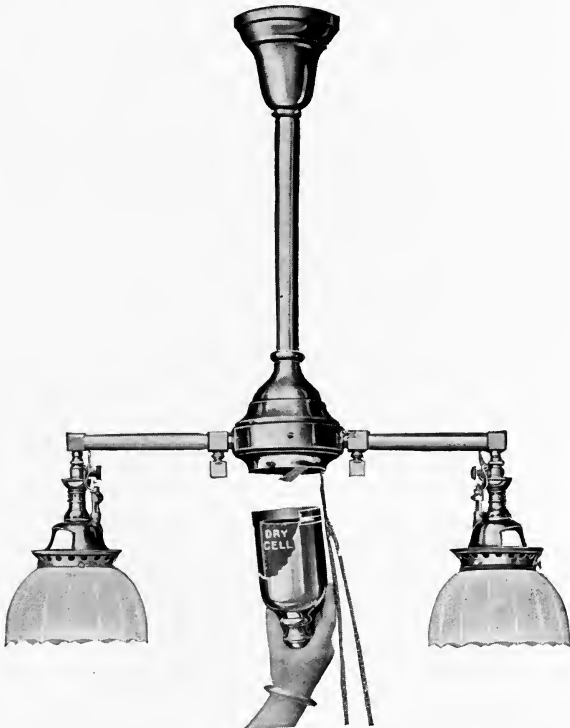

Fig. 13.—Self-contained fixture operating by "hot-wire" ignition.

Pilot flames may be protected against draughts to some extent by a shield (Fig. 14) but this expedient is not sufficiently effective to render the ordinary pilot an altogether reliable means of ignition.

During the past four or five years the pilot flame has been utilized to some extent as a low-intensity illuminant. When a small Bunsen flame is directed against the outside of a gas mantle the mantle area affected becomes to all intents and purposes a small incandescent mantle. A pilot flame of the Bunsen type consuming  $\frac{1}{8}$  cu. ft. per hour will if directed against a mantle, produce about  $\frac{1}{6}$  horizontal candle-power, as against  $\frac{1}{3}$  candle-power for a luminous or open flame consuming gas at an equal rate. This is sufficient to enable the occupant of a room to see his way about, to find keys or pull-chains controlling the lamps, and measurably to discourage those adventurers into high finance who operate at night and specialize in second-story operations.

A lamp equipped with such a pilot becomes a "high-low" unit operating at "low" continuously. Such a unit has a considerable field of application but the consumption of 90 cu. ft. of gas per month per lamp costing 9 cents per lamp per month with gas at \$1.00 per 1000 cu. ft. constitutes in many cases an obstacle to the general use of this system.

In 1916 a radical development appeared in the form of a pilot (Fig. 15) consuming but  $\frac{1}{16}$  cu. ft. per hour and of a very simple and inexpensive construction. This pilot consists of a tip surrounded by a small bundle of mantle fabric saturated with salts of rare earths which have been found effective in retaining the flame. This device possesses the remarkable property of being unaffected by breezes of 12 miles per hour, sufficient to blow a mantle of ordinary size from its supporting ring. A unit containing this device, combines an unailing means of ignition and a continuous small intensity of illumination,

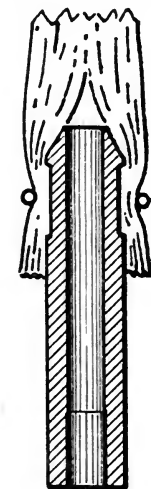

Fig. 15.—Section of new pilot tip with flame-retaining fabric of rare earths.

24 hours per day, at a cost of only 4.5 cents per month per lamp with gas at \$1.00 per 1000 cu. ft. or 45 cents per month for 10 lamps—about the number usually required in a 7-room dwelling.

A tabulation of pilot consumptions follows:



Fig. 14.—Protected pilot tip.

Lamp	Normal pilot cons. per hour (cu. ft.)	Approx. length of flame (inches)	Pilot cons. per year (cu. ft.)	Normal lamp cons. per hour. (cu. ft.)	Lamp cons. per year 4 hrs. daily (cu. ft.)	Pilot cons. per cent. of total cons.
1 Burner inv. indoor Bunsen pilot.....	0.120	$\frac{1}{4}$	1051.2	3.50	5,110	17.1
1 Burner upr. indoor luminous pilot.....	0.095	$\frac{1}{4}$	832.2	4.65	6,789	10.9
3 Burner inv. indoor arc, semi-Bunsen pilot.....	0.147	$\frac{3}{8}$	1287.7	10.00	14,600	8.1
5 Burner inv. outdoor arc, semi-Bunsen pilot.....	0.213	$\frac{1}{2}$	1865.9	17.50	25,550	6.8
1 Burner inv. indoor luminous pilot.....	0.152	$\frac{3}{8}$	1331.5	3.45	5,037	20.9
"Glower" pilot.....	0.04	....	547.5	....	....	3.0-10*

\* Depending on the size of lamp.

It may be frankly stated that prior to the development of this device the use of gas lighting imposed a certain unavoidable sacrifice of convenience due mainly to the faultiness of existing ignition systems, which may now be regarded as eliminated.

#### DISTANT CONTROL

The difficulty of controlling gas lamps from a distant point lies mainly in the necessity for controlling the flow of gas at a point near the lamp. If considerable pipe capacity is placed between the gas cock and the lamp the admission of the air in the pipe with the gas entering when the cock is turned on, may be sufficient to cause the flame to "flash back" to the orifice, and in any case the nearer the cock to the lamp the less violent the ignition of the gas. Distant control therefore necessitates means of operating a gas cock at or very near to the lamp. Usually a very small amount of energy must suffice for the actuating of the gas cock. Unfortunately, the most satisfactory type of cock is the "plug" type in which a tapered plug containing a gas-way is ground into a tapered seat, in which it turns. On account of the large bearing surfaces the friction is considerable, and though it may be much reduced by proper lubrication, the grease used is soluble in some of the gas constituents (notably benzol) which liquefy at the temperatures occasionally met in practice and dissolve the lubricant, thereby making a considerable increase in the energy required to actuate the cock. Another form of valve consists of an annular knife edge making contact with a flat seat. Such a valve is easily actuated and requires

no lubricant, but may be kept from operating by small particles of scale falling between the knife edge and its seat, thereby preventing the closing of the valve and resulting in leakage. The probability of failure through this cause may be greatly reduced by proper design, and many very satisfactory valves have been constructed upon this principle.

Gas valves for remote or distant control may be actuated by air pressure, by gas pressure or by electricity.

One of the simplest examples of the application of the former method is the pneumatic cock, consisting of a cylindrical plug with gas-way which moving axially in a cylindrical seat controls the flow of gas to the lamp.

A small hand pump having a bore of about  $\frac{3}{4}$  in. and a stroke of from 1 to 3 in. furnishes the impulse, transmitted through a small tube of  $\frac{1}{12}$  in. inside diameter, which moves the cock, a single impulse of compression or rarefaction sufficing to open and close the gas way respectively. This device is simple, inexpensive and when carefully designed, constructed and installed, reliable. Unfortunately most of the commercial types which have been offered, lacked the first two qualifications, and were so designed as to render the accomplishment of the third difficult.

Another form of gas-pressure-actuated valve consists of an inverted bell over mercury, the bell serving as the valve proper and the mercury as the "seat." The bell is weighted so as to be lifted and sustained clear of the mercury by the gas-pressure required to operate the lamp, sinking and cutting off the gas supply when the pressure is reduced below a predetermined point. The controlling valve is fitted with a by-pass which admits enough gas to supply the pilot flame at the lower pressure when the main gas supply is turned off. Valves of this type must be located at a sufficient distance from the lamp to avoid evaporation of the mercury by heat.

A simple and reliable automatic shut-off for extinguishing the lamp-flame at a predetermined time consists of a clock incorporated into the gas-cock arm, the latter being in a horizontal position for turning the gas on. At the predetermined time the clock disengages the chain which maintains the arm horizontal, the weight of the clock and arm then closing the cock.

In another type of gas-pressure-actuated valve the valve proper is a flexible metal diaphragm seating against an annular knife-edge. The space opposite the seat is connected with the main gas

supply pipe by a small controlling pipe. At any convenient point in the small controlling pipe a three-way cock is installed, which in one position, connects the main gas supply with the diaphragm chamber opposite the valve-seat, and in another connects the diaphragm chamber with the outer air. In the first position the pressures on either side of the diaphragm are equalized and the valve is closed. In the second position the pressure in the chamber opposite the seat is reduced to that of the atmosphere and the gas pressure on the seat side of the diaphragm opens the valve.

### ELECTROMAGNETIC VALVES

Two forms of electrically operated valves are in commercial use in this country. In one the armatures of two electromagnets actuate a tapered plug gas cock of the ordinary type, one turning the gas on and the other off. On account of the energy required to operate a cock of this type, it is desirable that the magnet be of efficient design in order satisfactorily to utilize the limited amount of energy available from small dry batteries. Most of the commercial types fail to realize the possibilities of this system in this direction and these valves are principally used in interior installations. They are comparatively expensive and do not enjoy extensive commercial use. Four ordinary dry batteries are required for one valve.

In a recent valve of the electromagnet type use is made of a polarized core in a solenoid controlled by a reversing switch. The valve itself consists of a diaphragm seating upon an annular knife edge. The normal position of the diaphragm is in the open position, seating being accomplished by the weight of the solenoid core, assisted by a spring; current in one direction lifts the solenoid core and the diaphragm, the residual magnetism retaining the core in its upper position after the current is turned off. Current in the opposite direction overcomes the influence of the residual magnetism and permits the core to fall, closing the diaphragm against the seat. One dry cell is sufficient to operate this valve and extremely satisfactory operation has followed its commercial application. It is somewhat more expensive than the previously described type of electromagnet valve, and is limited in commercial application to the larger units with which the cost of the valve is a relatively unimportant feature.

A recently developed magnet valve is shown in Figs. 16*a* and 16*b*.

The valve proper consists of a disc secured to the solenoid plunger by means of a ball and socket joint, ensuring accurate seating against the annular knife edge seat. A small spring secured in the plunger and bearing against the bore of the magnet spool prevents the un-

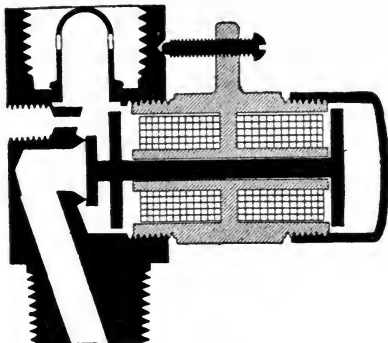

Fig. 16a.—Electro-magnetic gas valve, off.

seating of the valve from shock or vibration. This device is always installed with the annular knife-edge in a vertical plane so as to eliminate fouling from particles of pipe scale, and the seat is further protected by a small drip in the upper part of the valve.

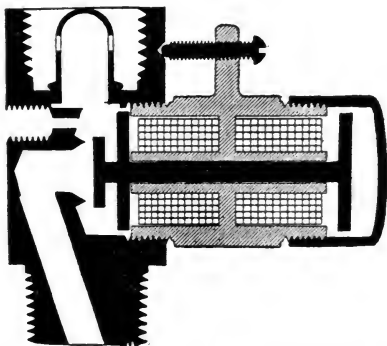

Fig. 16b.—Electro-magnetic gas valve, on.

#### GENERAL DESIGN OF LAMP AND FIXTURES

*Store Lighting.*—The development of means for securing highly efficient incandescence of the gas mantle without chimneys, cylinders or stacks has made possible a freedom and variety in design unattainable with the older types. As long as each mantle required enclosure

in a chimney or cylinder, or each small group of mantles in a globe, the output of individual lighting units was limited to about 300 c.p. and the design of attractive fixtures was difficult on account of the obtrusion of awkward mechanical features and the limitations imposed thereby. Figs. 17 and 18 show the burner arrangement and general appearance of new types of fixtures exemplifying the importance of recent developments in modifying and improving semi-indirect fixture design. Figs. 19 and 20 show other semi-indirect feature designs recently produced by leading American manufacturers.

Fig. 22 shows the plan of a 2000-c.p. semi-indirect fixture—the largest modern low-pressure unit thus far constructed—a type of

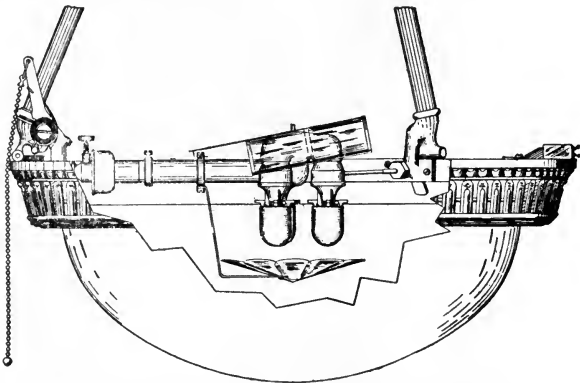

Fig. 17.—Arrangement of horizontal burners in semi-indirect fixtures.

design altogether impossible with the older lamps. Several of these units are in commercial service and have given excellent satisfaction. The fixtures as installed are shown in Fig. 21.

#### RESIDENCE-LIGHTING FIXTURES

It is generally recognized that the upright mounting of lighting units is preferable for the illumination of the more conventional interiors. The inherited sense of appropriateness by the satisfaction of which æsthetic requirements are governed, is based upon the almost universal use of the flame as a light source in the past. The tendency toward the inversion of the lighting unit—notable of recent years—had its impulse in consideration of economy, which have in a large measure been counterbalanced by improved efficiency in the use of illuminants, reduced cost of energy, and by the increasing

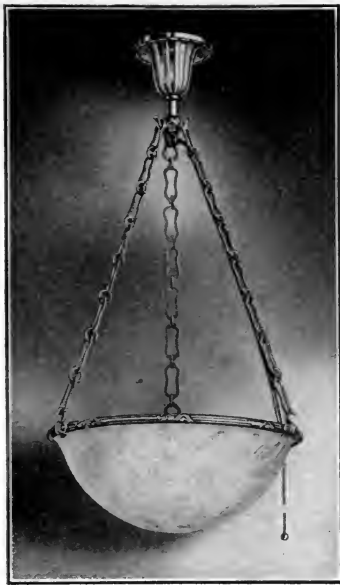

Fig. 18.—Recent type of semi-indirect gas fixture.

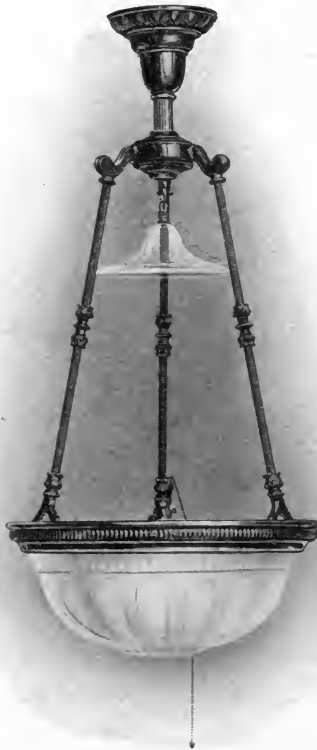

Fig. 19.—Recent type of semi-indirect gas fixtures.  
(Facing page 180.)



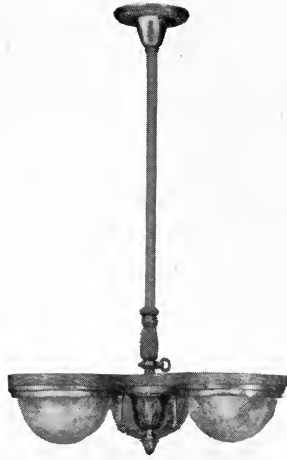

Fig. 20.—A novel design in semi-indirect fixture.



Fig. 21.—2000-c.p. fixtures installed. (The small fixtures belong to the previous installation.)

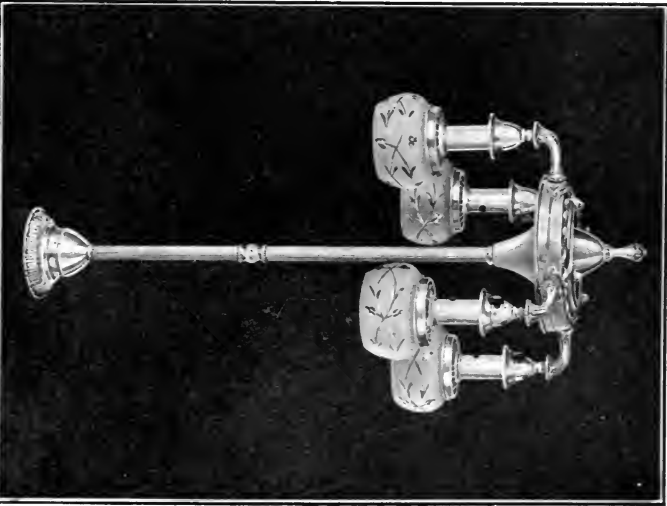

Fig. 23a.

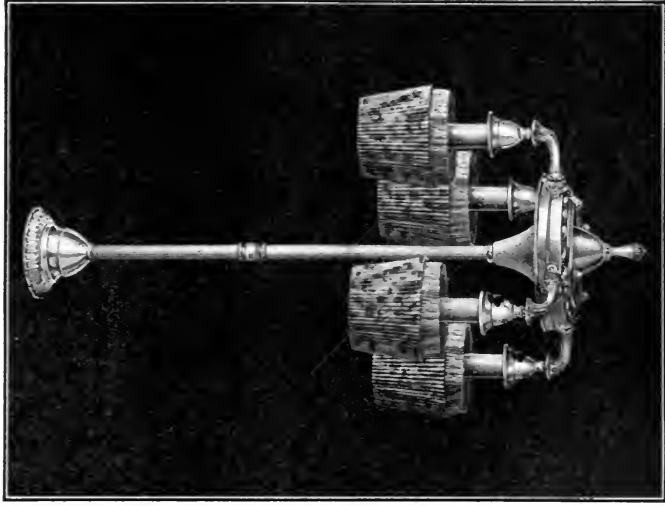

Fig. 23b.

Figs. 23a and 23b.—Recent applications of upright lamp shown in Fig. 7.  
(Following Insert, Figs. 20 and 21.)

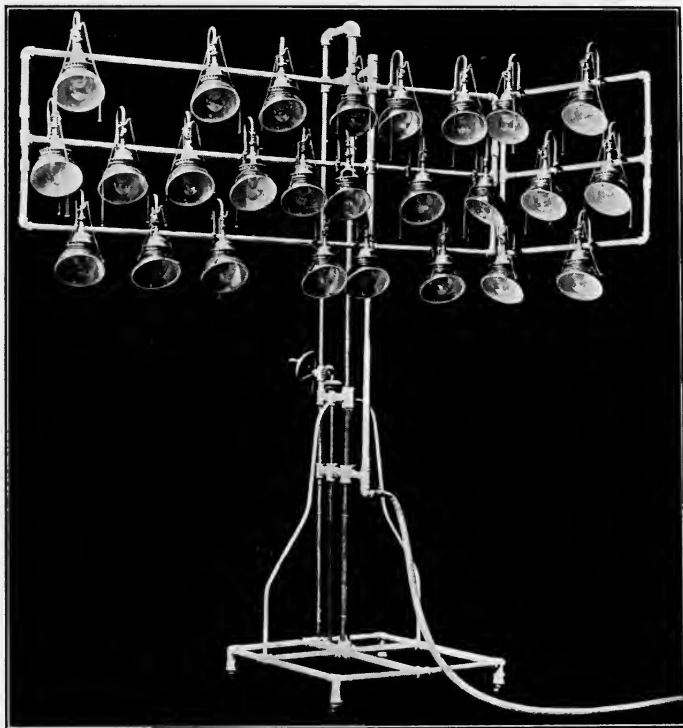

Fig. 24.—Incandescent gas-lamps arranged for lighting a photographic studio. Each lamp consumes  $4\frac{1}{2}$  cubic feet of gas per hour, and is fitted with a special mantle giving increased radiation at the shorter wave-lengths.

appreciation of the semi-indirect system of illumination. In the older upright gas lamps use was made of a mantle suspended from the top and open at the bottom. The mantle, freely swinging from its support suffered mechanically from the repeated striking of the lower portion against the burner head and the life was much shorter than that of the inverted mantle. Furthermore, the chimney required was an item of expense, and a source of annoyance by reason of the cleaning required. The development of the inverted mantle upright burner before mentioned (Fig. 7) has made possible the satis-

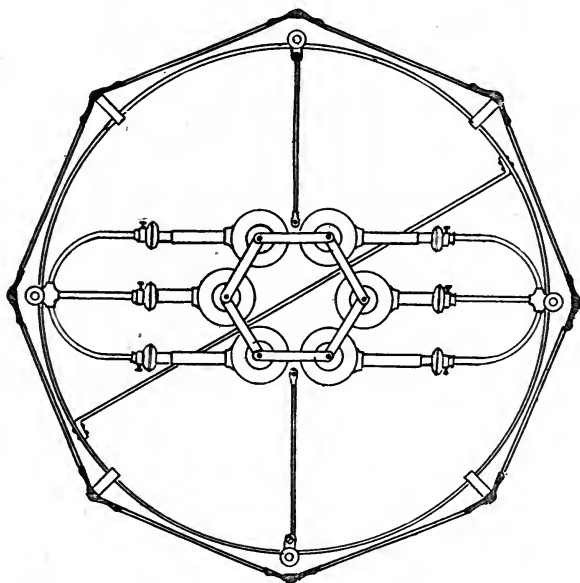

Fig. 22.—Arrangement of six 5-mantle burners with total candle-power of 2000 in 42-inch bowl.

factory and convenient use of gas in fixtures of the type shown in Figs. 23*a* and 23*b*.

The foregoing have been cited merely to emphasize the important influence upon fixture design of the mechanical simplification of the lamp. Though there is nothing unusual about any of these designs they really exemplify considerable progress for they represent the removal of great handicaps.

#### SPECIAL APPLICATIONS

Although the economic position of gas and the traditional conservatism of the industry have directed the principal developments

along the line of enhancing the value of gas lighting in existing uses and to existing customers, some interesting excursions into new fields have been conducted.

A great deal of shop-window lighting has been creditably done. In one city where some efforts has been directed toward developing this use, many of the leading exclusive stores in this city use the incandescent gas lamp for show-window illumination. The greatest obstacle to the use of gas for show-window lighting has been the expense of and the space occupied by the installation, the maintenance of clean glassware and the liability to pilot outage, since in most cases a distributed system requiring a large number of units is preferred.

#### PHOTOGRAPHY

Through the development of a mantle of low ceria content having a large energy radiation in the violet end of the spectrum, very creditable studio-lighting has been accomplished. Fig. 24 shows a studio lighting fixture consuming about 100 cu. ft. per hour by which portraits may be taken with shutter-drop ( $\frac{1}{5}$  second) exposures on Orthonon plates. Although no effort has been made to exploit this system a considerable commercial demand has spontaneously arisen.

The foregoing are indicative of the fact that gas lighting in its most recent development is susceptible of a much more extended and diversified use than it has enjoyed in the past, and waits only upon the expenditure of energy on commercial activity in the less frequently exploited fields.

## MODERN LIGHTING ACCESSORIES

BY W. F. LITTLE

The term "accessories" is here used not in its general sense, but rather according to the definition of the Committee on Nomenclature and Standards as employed to designate reflectors, shades, globes and other devices for modifying and controlling the light produced by lamps. The usual functions of such devices are to redirect the light; to diffuse the light; to interrupt the light in certain directions; to modify the hue of the light, or to protect the light source. Accessories in this sense are the tools with which the illuminating engineer works.

Since 1910 development in accessories has followed principally the lines of reduced brightness and improved appearance. The increased brightness of light sources has led to the development of accessories which partially or entirely conceal the source. These form in themselves a secondary light source and are capable of decorative treatment to a degree not offered by earlier forms of accessories. Prior to 1910 control of light flux was considered to mean very largely the re-direction of the light as desired. The progress of the past six years lies in the broader definition of control which now is considered to include not only control of the direction of light but also control of brightness and control of color. This extension of the functions of lighting accessories has not involved the abandonment of the most effective and flexible means of controlling direction of light, such as prismatic glass and mirror glass, but has brought about a more subtle and pleasing use of these means in combination with other means for softening and tinting the light.

The development of more efficient illuminants in this interim has brought not only the necessity for concealment of sources by lighting accessories, but also the opportunity to apply more effectively the less expensive illumination which they make possible. Accessories development is thus definitely involved with the improvement in light sources, without which such development would probably have been neither essential nor possible.

The increased brightness of the lamps, particularly in the smaller

sizes, makes some protecting substance advisable. Central station interests, as well as lamp manufacturers, are experimenting with certain bulb coatings which diffuse, and others which both diffuse and tint the light. A demand is beginning to manifest itself for a glass bulb to accomplish this same purpose.

Lamp accessories as above described may be made of a variety of materials and of innumerable shapes, and may still fulfil the requirements of the foregoing.

The material from which accessories are made may be classified in general as: Metal, enameled metal, glass, fabric, stone and pottery; and the shapes as: Flat, cone, bowl and miscellaneous.

From the standpoint of tabulation it is rather unfortunate that so many of the accessories fall in the miscellaneous class.

#### MATERIALS

The material should be selected with the proper weighting of the several optical properties of lighting accessories, namely reflection, transmission, and diffusion.

*Metal.*—Metal accessories applied as reflecting media have many advantages, such as durability and rigidity. However, few metal surfaces retain their high reflecting power unless the reflecting surface is protected. A few surfaces, such as polished or matte satin finish aluminum, have been used with some success. Aluminum bronze lacquer on metal is largely used, and has been found very satisfactory, particularly when properly protected from dust and moisture by a transparent coating. Aluminum finished reflectors without a protective surface have been known to depreciate 15 to 20 per cent. within a very short time, and once the surface lustre is gone the reflection coefficient is permanently impaired. The metal reflector with a porcelain or glass enameled surface has more than held its own during recent years for purely utilitarian purposes. The metal gives durability and rigidity and the enamel gives permanency of surface. The enamel surface is made so tough that it will withstand much abuse without cracking. Metal reflectors coated with paint, or baked enamel surfaces, make a reasonably satisfactory substitute, where they are not subjected to too much moisture or great changes in temperature. However, the reflecting power deteriorates rapidly and the surface becomes yellow with age.

*Glass.*—The best all round material for lighting accessories is glass, which although brittle is beyond question the most permanent

available for this purpose. On account of its reflection, transmission and diffusion it is far in the lead. Clear glass, with mirror backing, furnishes a combination of excellent qualities, such as permanency and efficiency.

*Fabrics.*—Silks, satins, chintz, etc., are much used for decorative effects where efficiency and permanency are not of importance or where they can be protected against depreciation.

*Stone.*—Marble, alabaster and several other minerals have been used to some extent where richness and distinction are sought.

*Pottery.*—Pottery is used where decorative effects and not efficiency are desired. Mirror reflectors are sometimes used in such accessories, thus greatly increasing their efficiency.

#### USES

The uses to which lighting accessories are put may be divided into four main classes: (1) utilitarian, (2) utilitarian and semi-decorative, (3) semi-utilitarian and decorative and (4) purely decorative.

*Utilitarian.*—The utilitarian accessory may be designated as one whose main functions are efficiency, light control, and in some cases color value, without serious regard to the appearance of the unit. Usually the accessory is a reflector, and in a few cases a shade or globe. Under this classification will be found a wide variation of materials and types such as: Enamel, aluminum, aluminum bronze, white glass, mirror glass and clear glass. Among the most practical is the white enameled steel reflector. Its permanency and durability of surface and practical indestructibility, coupled with its high coefficient of reflection and diffusion, have caused it to be very widely used.

Aluminum and aluminum bronze reflectors fulfill most of the functions of the enameled reflector, with slightly better light control, though the permanency of surface even when protected is not so good. White diffusing glass, where protected from breakage, is efficient and durable. Mirror and prismatic reflectors, by reason of their flexibility of light control have a field of usefulness. Clear blue glass units for color matching also fall in this class.

*Utilitarian and Semi-Decorative.*—The utilitarian and semi-decorative lighting accessories must be reasonably efficient, accurate in light control, and present an appearance which is unobjectionable. Of this class the majority of accessories are reflectors, a few are bowls, and a few globes, and as a rule these are made of white, clear and mirrored glass. For this purpose the white diffusing glass is perhaps



most used, though prismatic and mirrored glass are also employed and in some cases the "crystal roughed inside" globe is still retained.

*Decorative and Semi-Utilitarian.*—In the decorative and semi-utilitarian class the principal functions necessary are, a thoroughly satisfactory appearance and a reasonable degree of efficiency and effectiveness. The effectiveness must not only be measured by the ratio of output to input, but also in terms of light control and satisfaction. Light control in this connection is not necessarily light re-direction, but is the securing of the proper balance or weighting of reflection, transmission, and diffusion. This class embraces the reflector, the transparent, translucent and opaque bowl, and the transparent and translucent globe. It is therefore essential that a wide range in these qualities be available. The materials from which these are usually made are: white, clear and mirrored glass, tinted or colored glass and fabrics. In this class may be placed the white diffusing glass where transmission and diffusion are important; the prismatic and mirrored glass where control and efficiency are important; tinted or colored glass, and fabrics where colored light and decorations are required.

*Decorative.*—The decorative accessory may be of such varied construction, design or material that it may include anything from the bare light source to the most inefficient and highly absorbing media. It includes the reflector, the shade, the bowl, the globe and other forms which cannot be classified. In many cases the decorative feature is all-important and the illuminating value is a secondary consideration. The materials from which these accessories are made are: white, tinted or colored glass, iridescent and art glass, fabrics, stone and pottery. The white glass, tinted with a superficial coating of enamel, paint, or iridescent glass, is much used. This superficial coating may be etched away, making innumerable possibilities for ornamentation; or the white glass may be employed in its usual form with the walls of the accessory varied in thickness, in order to bring out the decoration in relief. The use of colored glass, iridescent glass, art glass, fabrics and pottery is extensive in this type of accessory, and glass has supplanted to a considerable extent the metal work formerly utilized.

#### STRUCTURAL CHARACTERISTICS

The glass used for lighting accessories may be divided into four structural types: Clear glass, opal glass, cased glass and suspension glass. The clear or crystal glass is used in the manufacture of prism,

“ground” and “daylight” accessories; the white, “opal” type of glass for accessories in which the complete mix is homogeneous; the cased glass, in which is a combination of the crystal or colored glass and refined opal, and “diffusing” glass which may be described as crystal glass with small reflecting particles held in suspension (alabaster type).

With these four types of glassware the manufacturers make practically all of the more popular grades of accessories. To be sure each manufacturer has his own way of treating his product, and his own slight variation of the mix and firing in order to give some characteristic finish.

“The crystal glass is the ordinary clear glass when applied to illuminating glassware. This must not be confused with other crystal glass which is used for cut glass, tableware, etc. The former is a common flint glass with no particular brilliancy, and is of a more or less inferior quality in so far as the glass itself is concerned. In the latter case, the glass is a highly refined decolorized prismatic glass, having unusual brilliancy. As the commoner type of crystal glass meets all the requirements for illuminating purposes, it is generally adopted for this class of work.”<sup>1</sup>

The opal type of glass is the basis of a large portion of all diffusing glass, and is made in a number of degrees of refinement, from the cheapest muddy white glass, as used in the earliest type of flat-shades, to the refined opal used for casing purposes. Very different and varied effects can be secured by surface treatment, and by varying the thickness of different portions of the glass. The thin portions show in many cases a fiery red; the thicker ones a pure white transmission. This characteristic is frequently taken advantage of in working the design in the glassware. On the other hand opal glass may be so made that it gives almost a pure white light transmission. With the refinement comes a more nearly perfect diffusion, and the glass usually becomes more dense. With the increased density the flashing or cased process is usually employed. The casing may be either on the inside, outside, or on both sides of the crystal glass, and the layer of casing may be as thin or thick as desired, thus giving a large range in transmission and diffusion.

The surface treatment may be an acid etch (wax or satin finish), a sand blast, or a superficial tinting applied with an air brush or other means, and fired in, making a fairly permanent surface. The tinting may be shaded off by spraying the surface at an angle so that shades and shadows are produced. The glass may also be covered

<sup>1</sup> Contributed by Mr. A. Douglas Nash.

with an enamelled tinted surface which is frequently etched away in patterns. Other methods of treating the surface, such as chipped glass, make very effective finishes. The chipping process is accomplished by covering the surface of the roughed glass with a specially prepared mucilage or glue, and then placing the glass in a furnace and allowing the paste to shrink away, pulling small particles of the glass with it. The opal glass is suitable for all classes of manufacture, while the cased glass is made only by the blown process. Tinted glass may be made having the same structure and characteristics as the white opal, the tinting being in the glass and making a homogeneous mass. This glass is of course selective in reflection and transmission, and therefore not highly efficient. However, it has possibilities as a practical lighting glassware, where color effects are desirable.

The alabaster type (sometimes called phosphate or alumina glass), or crystal glass holding small reflecting particles in suspension, forms the basis of many diffusing accessories. This glass may be made in varying degrees of density, from almost transparent to almost opaque. It may be either blown or pressed. The formulas and methods of working this glass are varied so that each manufacturer may secure his characteristic types. Glass is produced with particles so fine that the mass appears homogeneous, or the particles may be sufficiently large to be readily seen. The texture may present a pure white appearance, or a watery appearance. It may be left as it is taken from the iron mold, or it may be finished with a high gloss or fire polish. When blown this glass is usually thin, highly translucent, and in many cases poor in diffusing qualities. When pressed it is usually more dense, and better in diffusing qualities. A tinted glass of this same character has been produced, but up to the present time there has been but little on the market.

Some effort has been made to secure perfect diffusion from clear crystal glass. This, of course, would show a very high transmission value with very little absorption. However, it will probably have the disadvantage of appearing as bright as the light source in numerous small spots. This same phenomenon manifests itself to a considerable extent in prismatic glass, particularly where the prisms are not sharply cut.

#### MANUFACTURE

*Metal.*—The processes of manufacture of metal accessories need but little explanation. However, they may be classified as follows:

*Process.*—Spinning and pressing.

*Finishing.*—Polishing, etching, spraying, and enameling.

The metal reflectors are either spun on a form or pressed in a die. The finishes consist of polishing the metal, scratch brushing or acid etching the aluminum surfaces, or spraying aluminum bronze on the surface and enameling with porcelain or paint. A considerable increase in the life of the aluminum surface is secured by the use of a transparent coating which prevents the removal of the aluminum when cleaning and there are no roughened surfaces to accumulate dust. The porcelain enamel is applied as a liquid, and fired in the furnace, each reflecting surface receiving at least five coats, each coat individually fired.

*Glass.*—The glass accessories are manufactured from the different types of glass already described, by the following processes: blown, pressed, pressed-blown, cased, bent and offhand.

*Blown Process.*—The blown process consists of blowing a bubble of the glass in an iron or paste mould. The paste mould process is used whenever the accessory may be rotated in the mould; namely when smooth and without design. This mould is made of iron lined with paste. The rotating not only eliminates the seam in the glass but produces a highly polished surface. Where a pattern or design is traced on the accessory, an iron mould without a paste lining is used. In this case a seam corresponding to the parting of the mould will usually be found on the glass, and where a high polish is desired the accessory must be fire polished. The fire polishing is accomplished by re-heating the glass almost to the point of fusion and cooling it slowly.

The pressed process consists of placing the glass in the mould and pressing it by means of various shapes and types of plungers. The blown process is one of expansion or stretching, while the pressed process is one of compression. The blown accessory has its two surfaces, inside and out, parallel, and the glass is of approximately the same thickness throughout, while the inside surface of a pressed accessory does not necessarily conform to the outside surface, thus giving a wall of varied thickness.

Casing or flashing of glass consists of superimposing upon a core two or more layers of glass of different kind or structure. The casing is done while the glass is on the blow tube.

The very nature of this glass means that each layer has its own coefficient of expansion, which may differ from the adjacent layers. Therefore, the annealing process is more difficult, and after installa-

tion the ordinary cased glass may not be subjected to changes in temperature as great as in a glass of a homogeneous structure. However, if it is possible to secure the cases of glass having the same expansion characteristics the finished product compares favorably with that from a homogeneous mix, even though subjected to excessive temperature changes.

Many accessories are made of flat glass bent to the desired shape. The bending process is accomplished by making metal moulds lined with paste or chalk, laying the glass over the mould, and placing it in an oven which brings the glass slowly to the proper temperature so that it falls of its own weight, taking the shape of the mould. This does not change the texture or structure of the glass. The bent glass form may be cut and leaded to make a unit, or it may be left as taken from the mould.

Another operation which has proven very satisfactory and a great time-saver in the manufacture of globes is the pressed-blown process. A mould is made cone-shaped with a rounded tip, the top having the proper dimension for the opening in the globe. A blank is formed in this mould and while soft and plastic, placed in a second mould and the cone-shaped form is blown by compressed air to the desired shape. This process insures a greater uniformity in the accessory and retains the characteristics of blown glass.

“In the off-hand, or hand-made process, the glass is gathered in much the same way as in the two previous methods.<sup>1</sup> So called moulds are sometimes used to produce characteristic designs or marks on the glass itself. However, in this case, the piece of glass is dipped into these moulds before blowing, so that the raised portions chill more rapidly and retain this design during the process of making. In the case of opalescent glass, this treatment is of manifest advantage, as it results in the chilling of the raised portions. When the mass is re-heated, the chilled portions become more opaque than the core, and when completely blown, the design in the mould is shown on the piece by reason of this added opacity. This method of dipping is also used in the case of mould blown glassware, and has a tendency when blown into a paste-mould, of throwing the design or corrugations to the inside, giving a very effective lens-like appearance to the design. Hand-made glass lends itself to much more effective manipulation than any other process. Venetian glass has always been made in this way. Opportunities are offered for applying either to the core or semi-finished product designs in various colored glasses. When applied to the core, they produce designs which enlarge with the blowing of the piece, and the ultimate effect is a flat design in color. When applied to

<sup>1</sup> Contributed by Mr. A. Douglas Nash.

the semi-finished product the design is in relief, this latter method is elaborated upon by certain manufacturers by the use of pincers or some other suitable tool to form the applied glass into various shapes, producing very elaborate results. The well-known Salviati glass is the best example of a production of this character. In the production of Favrile glass, both methods are used. Owing to the fact that the coloring of glass has a tendency to somewhat change its chemical characteristics, these processes require unusual care in annealing, and in the production of some effects, the loss on this account is very great.

The annealing of glass is very important, each piece requiring a sufficient period of time to cool. The larger and thicker the piece the slower the cooling process. The annealing of large pieces is most important as they are usually thick and heavy and breakage after installation may be serious, not only as to cost but also from a standpoint of safety.

"This argument leads to the matter of annealing as applied to all classes of glassware used for lighting purposes.<sup>1</sup> The modern use of large units has led many manufacturers to adopt special means of annealing. In normal glassware, the annealing process should take not less than twenty-four hours, during which time the article should be very gradually reduced from its working temperature to atmospheric temperature, but additional time should be given to this when the weight or size of the article varies as in the case of pressed glass. The imperfectly annealed article may break from no apparent cause.

#### OPTICAL PROPERTIES

*Reflection.*—The coefficient of reflection as defined by the Committee on Nomenclature and Standards of the Illuminating Engineering Society is: "the ratio of total luminous flux reflected by a surface to the total luminous flux incident upon it. . . . The reflection from a surface may be regular, diffuse or mixed. In perfect regular reflection all of the flux is reflected from the surface at an angle of reflection equal to the angle of incidence. In perfect diffuse reflection the flux is reflected from the surface in all directions in accordance with Lambert's cosine law. In most practical cases there is a superposition of regular and diffuse reflection.

"Coefficient of regular reflection is the ratio of the luminous flux reflected regularly to the total incident flux.

"Coefficient of diffuse reflection is the ratio of the luminous flux reflected diffusely to the total incident flux."

Polished metal, mirror, clear and prismatic glass—in fact any highly polished surface—follow the law of regular reflection and the coefficient varies with the perfection of the surface and angle of incidence.

<sup>1</sup> Contributed by Mr. A. Douglas Nash.

Enamel and white glass with polished surface follow both laws of reflection, while matte surfaces such as aluminum bronze, depolished or rough glass, normally tend to follow the law of diffuse reflection.

No surface will produce perfect diffusion for the reason that all surfaces reflect regularly to some extent. The quantity of diffuse reflection will vary to some extent according to the perfection of the surface.

*Transmission.*—The light transmission through glass will depend upon its density, its surface and index of refraction. Referring to the Fresnel formula<sup>1</sup> for light transmission through glass, it is seen that through the ordinary sheet of glass whose index of refraction is 1.5, there can be only 92 per cent. of light transmission, neglecting absorption. This is for the reason that approximately 4 per cent. of the incident flux is reflected from each surface. Some recent experiments in the oxidation of glass surfaces show an apparent reduction in the index of refraction of the outer surface which has reduced this reflection from 8 per cent. to approximately 3 per cent. This apparent change in refractive index when applied to a lens does not in any way change its focal length.

Light may be transmitted through glass in several different ways, as

1. Transmission without redirection.
2. Transmission with redirection without diffusion.
3. Transmission with redirection and diffusion.

Transmission without redirection is the transmission of light through clear glass having both sides parallel.

Transmission with redirection without diffusion is the phenomenon secured with the use of totally reflecting prisms and mirror.

Transmission with redirection and diffusion is that which is secured when light is passed through roughed or ground crystal glass or through white diffusing glass. The degree of redirection and diffusion in white glass is dependent upon the quality of the glass and character of the surface.

The absorption of light in glass is a difficult property to measure. It has been stated that the absorption of light in clear optical glass is approximately 3 per cent. per inch. Light absorption in glass is the difference between total flux of light on the glass and reflected light plus transmitted light.

Table I-IV shows the per cent. of light reflected, transmitted and absorbed for various flat and nearly flat samples of clear

<sup>1</sup> Fresnel formula, "Light Transmission through Telescopes"—F. Kollmorgan, paper read before the New York Section of the Illuminating Engineering Society, Jan. 13, 1916.

and diffusing glass and the per cent. reflected for opaque surfaces. These values are indicative only of the range in reflection and transmission for the several classes of surfaces and materials, for the reason that the perfection of the surfaces and the thickness of the glass may not, and in some cases do not, represent average conditions. Further, the values of absorption represent the per cent. absorbed of the total flux falling upon the glass, and not the per cent. absorption of the light which enters the glass; for instance, the Calcite sample reflects 80 per cent., therefore 20 per cent. enters the glass and 7 per cent. is transmitted, or 65 per cent. of the light entering the glass is absorbed.

TABLE I.—PER CENT. REFLECTED, OPAQUE MATERIAL; LIGHT INCIDENT AT 20°

	Per cent. reflection
New Aluminum Bronze (unprotected).....	54
Corrugated Mirror.....	80
Polished Brass.....	60
Polished nickel plate.....	64
Polished silver plate.....	90
Polished Aluminum.....	67
Baked White Enamel (Paint).....	72
High Gloss Porcelain Enamel.....	78
Mat Surface Porcelain Enamel, Sample No. 1.....	79
Mat Surface Porcelain Enamel, Sample No. 2.....	76
Regular Surface Porcelain Enamel, Sample No. 1.....	73
Regular Surface Porcelain Enamel, Sample No. 2.....	75
* Silvered Mirror.....	83
* Uranium Glass Silvered Mirror.....	79

\* Mirrors supplied by C. A. Matisse.

TABLE II.—PER CENT. REFLECTED, TRANSMITTED, AND ABSORBED, CRYSTAL GLASS; LIGHT INCIDENT AT 20°

Thickness (mm.)		Per cent. reflected	Per cent. trans- mitted	Per cent. absorbed
4	"Pebbled"—smooth side.....	18	81	1
	rough side.....	13		
3½	"Roughed"—smooth side.....	25	69	6
	rough side.....	13		
3½	"Cathedral" Glass—smooth side..	25	74	1
	rough side.....	20		
3	"Clear".....	11	88	1



TABLE III.—PER CENT. REFLECTED, TRANSMITTED AND ABSORBED; LIGHT INCIDENT AT 20°

Thick- ness (mm.)	Sample	Dense			Medium			Light		
		Per cent. ref.	Per cent. trans.	Per cent. abs.	Per cent. ref.	Per cent. trans.	Per cent. abs.	Per cent. ref.	Per cent. trans.	Per cent. abs.
	Opal glass									
2	Blanco R.O.*					25				
2	Blanco*								39	
2	Acemelite*								39	
2½	Monex No. 1.							46	49	5
2	Monex No. 2.							44	48	8
2½	Sudan:*									
	Polished side				59	29	12			
	Depolished side				57					
2	Magnolia R. O.:									
	Polished side				59	29	12			
	Depolished side				56					
1½	Radiant*							46	49	5
4	Calcite No. 1:									
	Polished side	80	7	13						
	Iridescent side	78								
4	Calcite No. 2:									
	Polished side	79	12	19						
	Iridescent side	76								
3	Milk glass:									
	Polished side				74	12	14			
	Roughed side				70					
3	Veluria*								48	
4	Equalite:									
	Polished side				66	26	8			
	Semi-polished side				64	26	10			
	Cased glass									
4	Polycase*						36			
4	Camia*						36			
3	Acme Cased*								50	
2	Sheet Glass							48	43	9
4	Celestialite (Three Layers)	54	26	20						
	Suspension glass									
3	Parian Treated (R.I.)*								54	
9	Parian Pressed*		33							
4	Carrara*								50	
2	Blown Alba No. 1.							30	66	4
2	Blown Alba No. 2.							29	69	2
7	Pressed Alba No. 1.				48	48	4			
6	Pressed Alba No. 2.	56	42	2						
6	Alba R. O. No. 1:									
	Smooth side				48	46	6			
	Rough side				45					
6	Alba R. O. No. 2:									
	Smooth side				43	48	9			
	Rough side				43					
3	Druid*							37	56	7

\* Samples slightly curved. Values therefore questionable.

TABLE IV.—PER CENT. REFLECTED, TRANSMITTED AND ABSORBED IRIDESCENT ART GLASS; LIGHT INCIDENT AT 20°

Thickness (mm.)	Sample	Per cent. reflected	Per cent. transmitted	Per cent. absorbed
	Gold.....	13	21	66
	Silver on Opal.....	43		
	Gold on Opal.....	50		
	Pink on Opal.....	29	10	61
	Deep Blue.....	4	2	94
PER CENT. REFLECTED, TRANSMITTED AND ABSORBED, ROUGH ART GLASS; LIGHT INCIDENT AT 20°				
2½	Art Fire Opal: polished side	17	15	68
	smooth side	29	14	57

## ANALYSIS OF LIGHT LOSSES IN ENCLOSING FIXTURES

The light lost in the several parts of a fixture is shown in the following tabulation. The tests have been made on two street lighting fixtures.

- (a) Loss of light in housing.....16 per cent.  
 Loss of light in glassware.....16 per cent.  
 Loss of light in complete fixture.....36 per cent.
- (b) Loss of light in housing.....18 per cent.  
 Loss of light in glassware.....15 per cent.  
 Loss of light in complete fixture.....37 per cent.

It will be noted that the sum of the losses in the glassware and housing is less than the loss in the complete unit. This is occasioned by the fact that the globe reflects additional light into the housing, thus increasing the loss in the housing.

SKYLIGHT GLASS<sup>1</sup>

The glass in plate form used in ceiling windows or the so-called "skylights" backed by lamps is receiving more attention than heretofore. Crystal glass with various diffusing surfaces is available in sufficient characteristic forms to enable the engineer to secure almost any light distribution required, from the slightly diffusing to the widely distributing. Also the surface may be covered with prisms to bend and redirect the rays of light.

<sup>1</sup> I. E. S. Transactions, Vol. 9, page 1011, "Lighting of Rooms through Translucent Glass Ceilings," by Evan J. Edwards.

## REFLECTOR DESIGN

With the more concentrated light sources as found in the gas-filled tungsten or "Mazda C" lamps comes more accurate light control from reflectors. Also the problem of reflector design is simplified. Remembering that the angle of reflection is equal to the angle of incidence wherever the surface follows the law of regular reflection, it is obvious that the widely distributing light distribution may be secured in either of two ways, viz:

The rays may cross, or diverge. If they are to cross, a deep reflector must be used and a large percentage of the light impinges upon the reflecting surfaces. Conversely if the rays diverge little light falls upon the reflecting surface. Thus less control is secured. Obviously, therefore, the crossed rays allow a more accurate light control and at the same time tend toward a better concealment of the bright source.

The concentrating reflector must produce more or less parallel rays, and therefore, must approach the parabolic in shape.

The majority of types of light distribution range between these two. Therefore, the surfaces need but slight modification to secure the required results. As a rule when properly designed the deeper the reflector the better the control and greater the light loss.

To produce a predetermined light distribution with a diffusely reflecting surface is more difficult and sometimes impossible. However, the same principle is followed.

No symmetrical reflector, or one whose surface is a surface of revolution, will increase to any marked degree the light in a horizontal direction about a lamp. The so-called deflector was designed with this idea in view, with a surface parabolic in shape and the source in the focus. But in order that a fair percentage of the light should fall upon it its diameter would have to be so great as to make it impracticable.

An unnecessary loss is experienced in many accessories by trapping the light. This is very likely to be serious with the ventilated units for Mazda C lamps. The top of the accessory is usually closer to the filament than any other portion and subtends a larger solid angle of light, and therefore should be most active and valuable in light reflection. If this surface is not of the proper contour to throw the light out, the light loss in the unit may be excessive.

## PHOTOMETRIC PROPERTIES

*Metal Accessories.*—The metal accessories have kept pace with the change in lamp design and construction. With practically each change in filament dimension, shape or location it has been necessary to re-design the reflector. With the advent of the Mazda C lamp many changes were necessary.

*Aluminum Finished Reflector.*—The aluminum finished reflectors are essentially indoor accessories of the utilitarian type. They are made in deep and shallow cones and bowls, angle, trough or show-

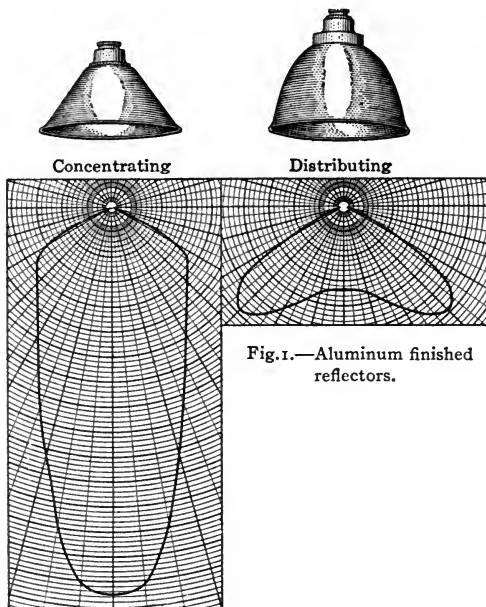

Fig. 1.—Aluminum finished reflectors.

case reflectors, and produce a complete range in distribution characteristics from the widely distributing to the moderately concentrating. They are designed for practically all types of electric lamps from the 10-watt Mazda B to the large sizes of Mazda C.

In Fig. 1 are shown characteristic candle-power distribution curves for bowl type accessories; the light loss to be expected in this type of reflector varies from 20 to 40 per cent.

*Porcelain Enameled Steel.*—The enameled steel accessory is somewhat similar to the aluminum finished with a slightly increased reflector coefficient. It has a wider application, as it may be used in or out of doors. It is made in all of the conventional reflector

shapes, and in addition, is designed for numerous asymmetric distributions, where large flat vertical surfaces are to be evenly illuminated. The light control is not as accurate as with the aluminum surface due to the diffusing qualities of the enamel.

Many of the reflectors, particularly of the deep bowl type, which are used with the large sizes of Mazda C lamps are constructed with ventilating hoods, and as they are frequently used with enclosing glassware the ventilation feature is doubly important. However, this ventilating feature is regarded by the manufacturer as becoming less important as the lamps are now constructed. Where re-

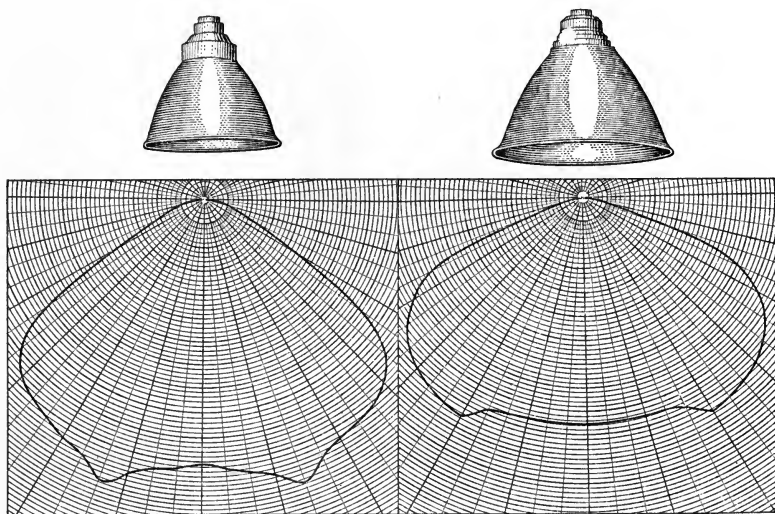

Fig. 2.—Porcelain enamel reflectors.

quired, enameled accessories without ventilators may be used with enclosing gas or vapor-proof glass envelopes.

Some of the types of deep bowls have been constructed with fluted surfaces for the purpose of eliminating bright streaks. These flutings or corrugations also add to the rigidity of the reflector. Characteristic candle-power distribution curves for these reflectors are shown in Fig. 2. The loss of light for enameled accessory will vary from 15 to 35 per cent.

*Painted Enameled Reflectors.*—The painted enameled reflectors are made in shapes similar to the more common types of porcelain enameled reflectors. However, their chief quality is cheapness.

The connecting link between the metal and glass accessories is the

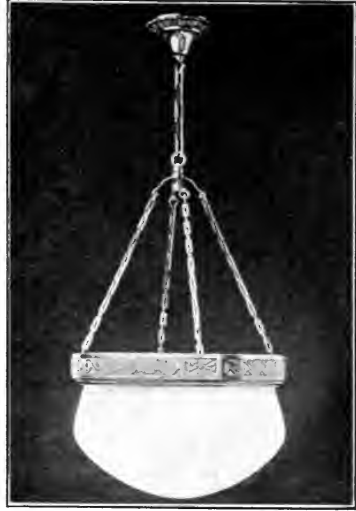

Figs. 3 and 4.—Connecting link between metal and glass accessories.

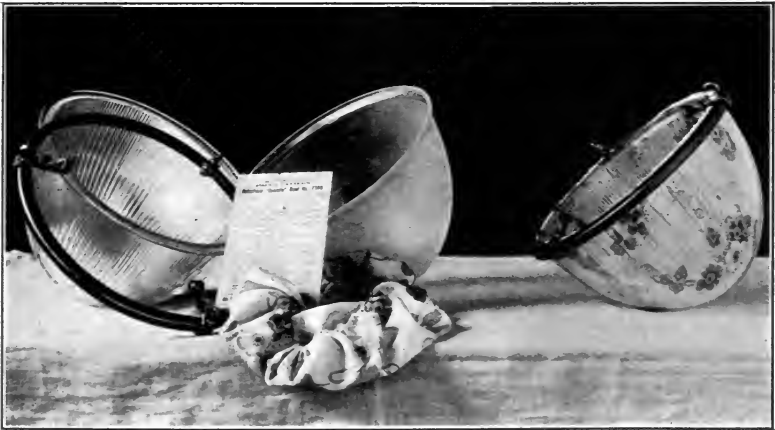

Fig. 5.—Prismatic semi-indirect unit.

(Facing page 198.)



Fig. 6.—Typical modern fixtures



Fig. 7.—Fixture to which may be attached a choice from a number of interchangeable bowls.

metal hood and enclosing or semi-enclosing glassware (Figs. 3 and 4). Many decorative and semi-decorative units have been designed embodying a hood or holder to which is attached the socket and glassware.

#### GLASS ACCESSORIES

The glass accessories lend themselves to practically all lighting purposes and are made up in innumerable designs. Unfortunately, however, with few exceptions the accessory is made to meet the ideas or tastes of the designer with little or no consideration for the light distribution. Among the exceptions, may be cited most prismatic and mirrored reflectors.

*Clear Glass.*—Clear glass is used in the manufacture of a number of types of accessories, namely: Clear; ground or etched; cut; prismatic, and mirrored.

Clear accessories are usually globes, the principal function of which is the protection of the light source.

Ground or etched accessories in some cases lend themselves to decoration, but it is regrettable that they must be classed as lighting accessories, as their diffusion is poor and light-redirecting qualities practically nil.

The only excuse for the existence of the cut accessory is to serve as a medium of decoration, though in a few units it produces some sparkle and life. Its redirecting qualities are, usually of little importance.

The so-called "daylight" unit is properly an accessory, which, when used with an artificial illuminant, will produce a light equivalent in color to daylight (north sky or sunlight). This corrective process usually consists in the use of the subtractive method of color correction or the reduction of all of the light in proportion to the ratio of the blue in the artificial light to the blue in daylight. The blue in most artificial illuminants is approximately 10 per cent. of north sky or 20 per cent. of sunlight. Therefore, the maximum theoretical efficiency obtainable is 10 per cent. for north sky, and 20 per cent. for sunlight.

However, where a whiter light is required than that produced by the bare lamp, it has been found satisfactory to employ an accessory which absorbs not over 50 per cent. This unit, of course, must not be regarded as a color-matching unit. A slight reduction in the red component frequently produces a very noticeable change in the apparent color of fabrics, particularly where the blues predominate.



Glass manufacturers have taken advantage of this fact and have made accessories with a thin casing of blue glass, usually on the inside, thus not changing the appearance of the unit during the daylight hours, but at night producing a somewhat whiter light than would otherwise be secured.

One claim for these modified units is that the light apparently mixes to better advantage with daylight or twilight than the light from the unmodified unit.

When a unit producing true daylight is to be installed where it can be contrasted with the unmodified artificial light, it appears very blue and observers do not believe it to produce light of real daylight quality.

From tests made at the Electrical Testing Laboratories there is an indication that transparent colored glass and gelatine increases in absorption toward the blue end of the spectrum. The following table shows the transmission values for red, green and blue light through corresponding colors in glass and gelatine.

Color of substance	Color of light	Per cent. transmitted	
		Jena glass	Wratten filter
Red.....	Red.....	92	90
Green.....	Green.....	55	36
Blue.....	Blue.....	30	23

Both the glass and the gelatine filters were supposedly designed for monochromatic light transmission, and the difference in transmission values between the two substances is probably accounted for in that the color in one case is purer than in the other; therefore, more nearly monochromatic. This absorption of light militates further against the efficient production of an accurate daylight unit by the subtractive method.

*Prismatic Accessories.*—Unlike the majority of accessories, the prismatic units are usually designed according to carefully worked out prototype curves. Light control is accomplished by the use of totally reflecting prisms which follow the general contour of the glass. Furthermore, prisms may be refracting as well as reflecting. In some units results have been secured by the use of both kinds of prisms. If the contour of the glass and shape of the prisms are properly formed, almost any light distribution may be secured.

Corrugations have been placed in glass for the purpose of diffusing light. These corrugations have been frequently called diffusing prisms.

Prismatic accessories are made in numerous designs, each having its characteristic distribution and function to fulfill. The conventional forms of prismatic reflectors are well known; therefore, only the newer types are here discussed. Totally enclosing prismatic units are made to control the light quite as accurately as the prismatic reflector with but slightly increased loss. In this way the light source can be entirely enclosed and still secure the desired light distribution. Combinations of prismatic glass with white diffusing glass make possible light control and elimination of glare such as would be impossible with either one alone (Fig. 5). A so-called semi-direct unit has recently been developed consisting of a prismatic reflector designed after a prototype curve using a clear glass or "velvet" finish glass envelope conforming closely to the contour of the reflector. Between these two is placed any fabric or paper to correspond with the surrounding decorations. With this unit it is possible to secure almost any desired ratio between the direct and indirect components of light unit brightness and at the same time secure decoration and color effects from the transmitted light.

Asymmetric prismatic reflectors have a large field of usefulness.

The refractor unit is notable in that it will to a marked degree redirect a large portion of the light at or near the horizontal. This accessory has also been made in the form of a band refractor which intercepts only the light above the horizontal, and this light may be redirected wherever required, adding considerably to the light in the lower hemisphere. The band carrying the refracting prisms is surrounded by a second band carrying corrugations or ribbings which diffuse the light in a plane normal to the surface, this producing a nearly uniform brightness over the entire band rather than a bright spot at its center.

An enclosing prismatic accessory is made with a standard reflector for the upper portion and refracting prisms for the lower portion. The refracting prisms break up and redirect the light falling upon them, thus helping to eliminate excessive glare. The same general function is performed by the reflector-refractor, which with its combination of reflecting and refracting prisms breaks up and redirects the light as desired.

A range in candle-power distribution curves which may be secured from prismatic accessories is shown in Fig. 8. To the left is an

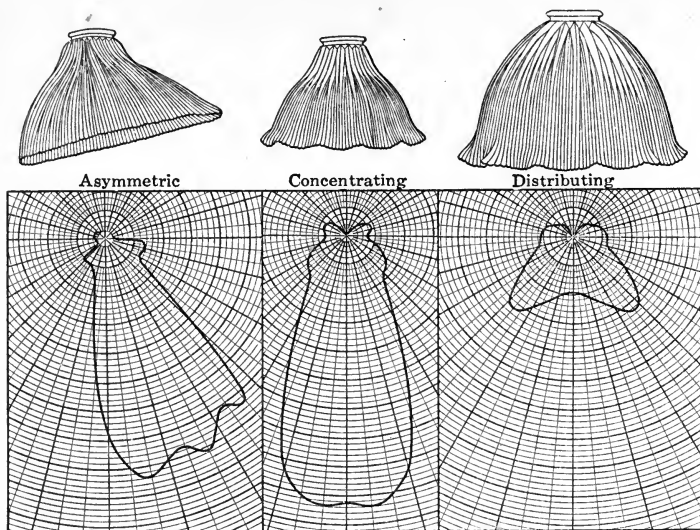

Fig. 8.—Prismatic reflectors.

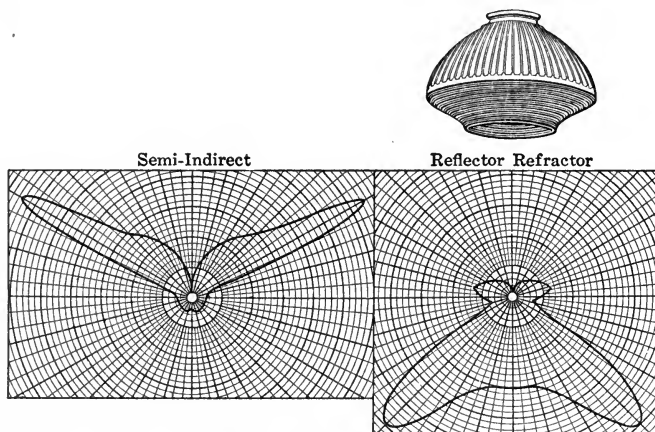

Fig. 9.—Prismatic accessories.

asymmetric reflector, the center a concentrating type, the right a distributing type. The losses to be expected in these reflectors range from 12 to 14 per cent.

In Fig. 9 to the right will be found a reflector-refractor showing a loss of light of about 20 per cent. thus showing large redirection from an enclosing medium with a relatively small loss. To the left will be found the candle-power distribution characteristic of a semi-indirect prismatic unit (see Fig. 5).

*Mirrored Accessories.*—The mirrored reflector, as in the case of the prismatic, is usually designed to produce a predetermined light

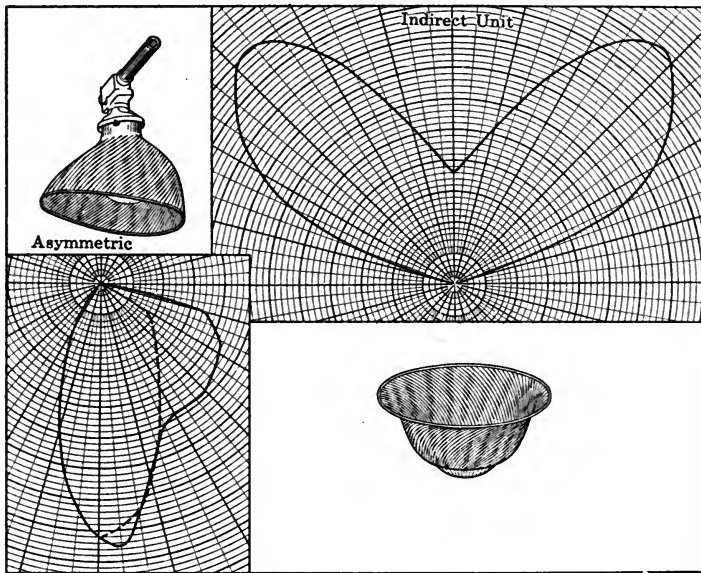

Fig. 10.—Mirrored reflectors.

distribution. Its efficiency is high and light control excellent. The problem, however, is to retain a permanent reflecting surface. This is a comparatively simple matter where not subjected to excessive heat or moisture. Deterioration from the former cause has proven a very formidable obstacle since the widespread use of the Mazda C lamp. The mirror reflector must consistently follow the changes in lamp construction, filament location and design, for the reason that it functions by the principle of regular reflection. Therefore its efficiency is closely related to its contour and location of light center. With the introduction of the concentrated filament it was

found that the corrugations in the reflectors made for the Mazda B lamps were not sufficiently fine or numerous to prevent bright streaks. This led to the development of a new series of reflectors with very fine waves or corrugations.

The flat corrugated mirror strips in trough reflectors are still much used. With this type of reflector extremely accurate light control in a plane normal to the axis of the reflector can be secured, as the strips can be made as wide or as narrow as desired and each installation may have a particular reflector designed for it.

In Fig. 10 is shown characteristic distributions of mirrored accessories. The light loss in these units is from 15 to 20 per cent.

*Diffusing Glassware.*—Diffusing glassware as used in lighting accessories furnishes a wide range in reflection, transmission and diffusion, and this range may be varied to a considerable extent in any one type of glassware by changing its density, its thickness, its surface and its contour. Added flexibility is frequently secured by coating the glass with a white enamel. The enameled surface has a high reflecting power and low transmission.

*Opal glass* is used in the manufacture of reflectors, bowls and globes. By the proper selection of thickness and densities varied effects may be secured. The dense opal accessory when properly shaped may produce an excellent reflector so far as light control is concerned.

When used in bowls it can be thin with high transmission or dense with little transmission. The diffusing qualities are very good, particularly in all cases when the surfaces are roughed.

	Per cent. reflected	Per cent. transmitted
Dense (4 samples).....	80 to 76	7 to 12
Medium (2 samples).....	74 to 70	12
Light (9 samples).....	59 to 45	29 to 49

The characteristic candle-power distributions to be expected from bowl reflectors of the opal type are shown in Fig. 11. To the left is the pressed reflector; to the right is the blown. The light loss in these reflectors ranges from 12 to 20 per cent.

Accessories made of cased glass are usually of the totally enclosing type as its principal purpose is high transmission coupled with good diffusion. Some so-called reflectors are made of cased glass but they

should rightly be classed among the shades. Occasionally the casings are made sufficiently thick to reduce the transmission to a comparatively low figure.

Bowls have been made of cased glass but the units are usually unsatisfactory, resulting in a very high brightness and small reflection.

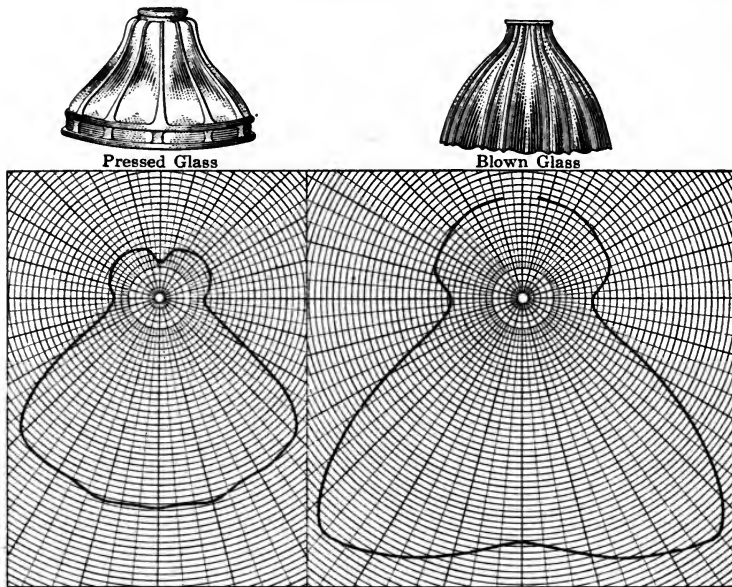

Fig. 11.—Opal reflectors.

	Per cent. reflected	Per cent. transmitted
Dense (1 sample, 3-layer glass).....	54	26
Medium (2 samples).....	.....	36
Light (2 samples).....	48	43 to 50

Fig. 12 shows a characteristic candle-power distribution for a cased glass bowl reflector. It will be noticed that the transmission is high and reflection low, the loss in this type being approximately 8 per cent.

The active interest in diffusing glassware found its beginning in the suspension type. Other diffusing accessories were made in opal, cased and roughed crystal glass, but not until the development of

the alabaster type did the use of diffusing glassware receive its full impetus. The flexibility of this glassware makes it particularly valuable.

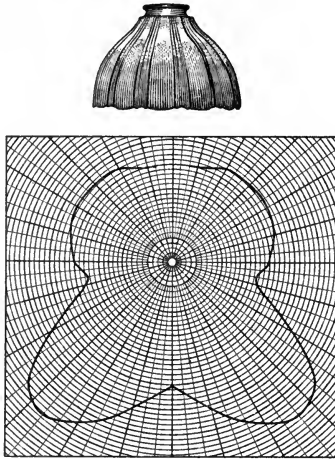

Fig. 12.—Cased glass reflector.



Bowl Reflectors

Dish

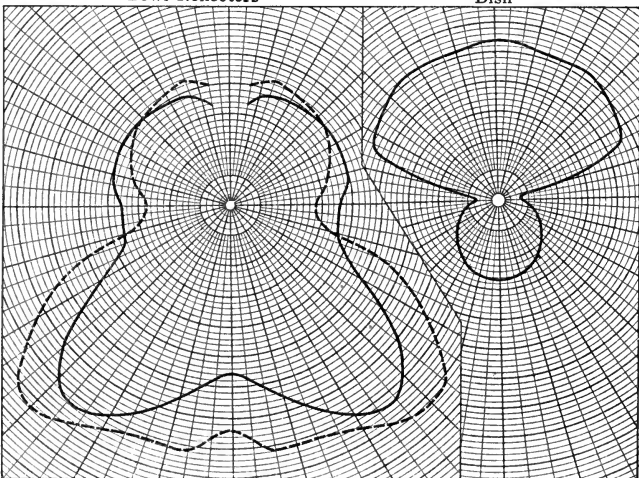

Fig. 13.—Suspension glass accessories.

	Per cent. reflected	Per cent. transmitted
Dense (2 samples) .....	56	33 to 42
Medium (5 samples) .....	48 to 43	46 to 48
Light (5 samples) .....	37 to 29	69 to 50

In Fig. 12 will be seen candle-power distributions for suspension glass accessories. To the left are two types of distribution curves both showing considerable transmission and comparatively little reflection. The loss in these accessories varies from 8 to 12 per cent. To the right is a suspension glass dish. The loss in this accessory is 11 per cent.

Suspension glass lends itself readily to either blown or pressed accessories made in either iron or paste molds. As its density varies from the almost transparent to the almost opaque, so also do its diffusive qualities. In the dense glassware fairly accurate light control may be secured. Therefore, it is used to good advantage in reflectors and bowls and the less dense glass is used in globes.

#### FIXTURES

The problem of good fixture design is complex and few designers approach it from the same standpoint. The introduction of bowls of diffusing glassware has to a very considerable extent curtailed the demand for the conventional (old-fashioned) fixture. This curtailment has been obviously caused by the entrance into the field of the glass manufacturer. In many cases the glass superseded the metal work in fixture. Had the fixture houses been as active in pushing the glass bowl type of unit as they were in pushing older, more conventional types, it probably would not have been necessary for the glass manufacturer to enter the field, and the types of fixtures might have followed a different style of design.

The fixture business may be divided into two principal classifications, the stock fixture and the special fixture. The stock fixture follows to some extent a definite period design. The special fixture is supposedly made to harmonize with a particular environment. As examples of the type of recent stock fixtures might be cited the candelabra wall bracket, usually using frosted round bulb electric lamps; the center candelabra chandelier, similarly equipped; the chandelier in the ring or bracket form using the same round bulb frosted lamps;



the dome in art glass or silk; the table lamp with glass or silk shades, Fig. 6. Possibly the only characteristic shape on the table lamp shade of silk is that of the frustum of a cone with the top diameter only slightly less than the bottom.

The officers of a much imitated fixture house which boasts of the pick of the trade and carries no stock fixtures assert that there has been no advance or characteristic change in fixture design for the past twenty years other than a tendency toward a larger number of lamps of lower intensity. They state that the crystal fixture is more popular than ever. The side-wall bracket is coming into great favor, in the majority of cases using the bare frosted lamp, and in some cases a silk shade or eye shield. In almost no case is glassware of any description used. They do state, however, that the table lamp is used to supplement the wall brackets and chandeliers. Further, apparently no effort is made to redirect or control in any way the light from the small round bulb frosted lamps. The light distribution characteristics of these fixtures is of no consequence whatever to these fixture designers. Even in the case of enclosing glassware the tendency is toward cluster rather than single unit lamps. When the diffusing bowl type of unit is employed it is frequently supplemented by candle brackets.

One of the representative manufacturers stated that the resultant illumination produced was almost never considered as part of his work, or part of the artistic and æsthetic feature of the installation as a whole. This state of affairs should be looked upon with considerable alarm by the illuminating engineers, particularly at this time when light source brightnesses are so decidedly on the increase.

An exception to this practice was found in one of the largest and best fixture houses in New York where the quality of light, light distribution and light control are the first conditions, and the design is worked around these. This house would not consent to showing designs or photographs of any fixtures, as such, without knowing where and under what conditions the fixtures were to be used. Here at least good taste and quality of light are paramount, and the purpose of the fixture in many cases is disguised in the design. This does not mean, however, that unnatural and disconcerting conditions are tolerated.

A very popular and satisfactory diffusing bowl unit is found in the alabaster accessory. The stone as it is taken from the Italian quarry is quite translucent and in some places almost transparent, thus producing a beautiful effect of fire and life without excessive bright-

ness. Unfortunately it must be used with discretion as it cracks readily and will blacken if not properly protected from the lamp. Here again little attention is given to shapes or designs which might produce an advantageous light distribution but as they are usually employed to produce a generally diffused illumination and supplemented with localized lighting, their distribution characteristics are of little importance. Beautiful designs have been worked out on these bowls, in some cases the depressions are colored with a sepia stain giving them a rich day as well as night value. The density of the stone is quite sufficient to keep the surface brightness down to a satisfactory value.

The total disregard of quality, fitness and distribution of light is not so prevalent among the glass- and reflector-manufacturers who also make fixtures. In many cases they are attempting to secure the desired weighting of transmission and reflection, and the tendency is toward a consideration for quality by tinting the glass. On the other hand, glass manufacturers are prone to consider their one or two types of glassware the panacea for all lighting ills, whereas a slight modification in the mix or density of the ware would make success of failure. Such a step in this direction has been taken by a fixture producer, in the design of a single stem from which are mounted either gas or electric lamps and to which may be readily attached any one of a number of bowls having different shapes, densities and colors, Fig. 7.

An improvement in the resultant illumination from semi-direct fixture is being accomplished by placing a thin diffusing glass plate over the bowl. This eliminates chain shadows and simplifies the cleaning problems.

Indirect fixtures are now made utilizing the accurately designed mirror reflector inside a diffusing glass bowl, and by means of an auxiliary lamp or a diffusing cup in the bottom of a mirror reflector the bowl is illuminated to the desired brightness. This arrangement to a very marked degree, eliminates the argument against indirect fixtures, namely, that the fixture appears dark against the illuminated ceiling.

Table lamps are also designed with some conception of the resulting light distribution. The lamps, using silk shades as above described, are frequently equipped with real reflectors which control the light produced. This shape will allow of a considerable upward component for a semi-indirect unit or may be equipped with a reflector throwing a large portion of the light downward. Fre-

quently the silk alone is used as a reflecting surface. Much flexibility can be secured as the silk may be left highly translucent or diffusing and additional layers may be added to secure the desired transmission and different colors for different effects.

In an effort to make semi-indirect units more universal and allow them to be used even where highly reflecting ceilings are not available or in those locations where the ceilings are too high above the logical locations of the unit the fixture manufacturer has designed a small portion of ceiling to go with the bowl. The fixture therefore consists of a diffusing bowl and a reflecting surface a short distance above. This method serves to enlarge slightly the light giving area, and thus to decrease correspondingly the fixture brightness. The upper reflecting surface has been changed in size, location and shape by the several manufacturers, but always serves the same purpose.

A survey of the field indicates that excellent accessories of a wide variety are available. As a rule, however, these follow conventional lines according to well recognized concepts of design and use. Only to a slight extent are designers undertaking to provide accessories which represent adaptation of simple means of directing, diffusing and tinting the light along unconventional lines.

### References

E. B. ROWE.—“Some tendencies in the design of illuminating glassware.” *Electrical Engineering*, September, 1914.

JAMES R. CRAVATH.—“Glass globes for street lamps.” *Municipal Journal*, August 27, 1914.

RENE CHASSERIAUD.—“The art of logical lighting (French).” *Societe Belges des Electriciens* (Brussels), May, 1914.

GUIDO PERI.—“Present status and tendencies in electric illumination (Italian).” *L'Industria* (Milan), November 1, 1914.

H. B. WHEELER.—“Lighting of show windows.” *Illuminating Engineering Society Transactions*, September, 1913.

W. W. COBLENTZ.—“The diffuse reflecting power of various substances.” *Bulletin of Bureau of Standards*, April 1, 1913.

H. J. TAITE and T. W. ROLPH.—“Notes on metal reflector design.” *General Electric Review*, May, 1914.

A. L. POWELL.—“An investigation of reflectors for tungsten lamps.” *General Electric Review*, November, 1912.

M. LUCKIESH.—“Investigation of diffusing glassware.” *Electrical World*, November 16, 1912.

W. W. COBLENTZ.—“Diffuse reflecting power of various substances.” *Journal Franklin Institute*, November, 1912.

L. BLOCH.—“Reflectors and accessories for lighting inner rooms with metal

filament lamps (German)." *Elektrotechnik Und Maschinenbau*, October 13, 1912.

DR. L. BLOCH.—"Reflectors for metal-filament lamps." *London Electrician*, March 21, 1913.

A. L. POWELL and G. H. STICKNEY.—"Data concerning incandescent reflectors." *Electrical World*, September 6, 1913.

VAN RENSSELAER LANSINGH.—"Characteristics of enclosing glassware." *Illuminating Engineering Society Transactions*, September, 1913.

W. T. MACCALL.—"Half frosted lamps in reflectors." *London Electrician*, October 3, 1913.

A. L. POWELL.—"Reflectors for tungsten lamps in industrial and office lighting." *Electrical Engineering*, October, 1913.

DR. L. BLOCH.—"Choice of reflectors for street lighting." *London Electrician*, May 31, 1912.

L. BLOCH.—"Choice of reflectors and proper heights for metal filament street lamps." *Elektrotechnik und Maschinenbau*, December 3, 1911.

R. HORATIO WRIGHT.—"The mazda lamps with a few common types of reflectors." *Sibley Journal of Engineering*, November, 1910.

C. TOONE.—"Globes, shades and reflectors." *London Electrical Review*, June 16, 1911.

P. G. NUTTING, L. A. JONES and F. A. ELLIOTT.—"Tests of some possible reflecting power standards." *Illuminating Engineering Society Transactions*, Volume 9, No. 7, 1914.

LEONARD MURPHY and H. L. MORGAN.—"Distribution and efficiency tests on lamp shades and reflectors." *London Electrical Review*, July 7, 1911.

GEO. H. MCCORMACK, ALBERT JACKSON MARSHALL, L. W. YOUNG; Introductory remarks by BASSETT JONES, JR.—"Symposium on illuminating glassware." *Illuminating Engineering Society Transactions*, September, 1911.

THOMAS W. ROLPH.—"Reflectors for incandescent lamps." *Electric Journal*, May, 1910.

J. R. CRAVATH.—"Show window illumination." *Central Stations*, May 1910.

C. E. FERREE and G. RAND.—"Some experiments on the eye with inverted reflectors of different densities." *Illuminating Engineering Society Transactions*, December 20, 1915.

FRANK A. BENFORD.—"The parabolic mirror." *Illuminating Engineering Society Transactions*, December 20, 1915.

HAYDEN T. HARRISON.—"Efficiency of projectors and reflectors." Abstract of a paper read before the Liverpool Engineering Society.



## LIGHT PROJECTION: ITS APPLICATIONS

BY E. J. EDWARDS AND H. H. MAGDSICK

Light projection, as the term is commonly employed, covers the redirection of light flux from artificial sources by means of suitable optical systems so that it may be utilized within solid angles which are small as compared with those encountered in equipment for general illumination purposes. It was in connection with such applications in a few restricted fields that some of the more important principles of optics and illuminating engineering were long since developed and applied. During the past few years these applications have multiplied rapidly, occupying the attention of many illuminating engineers and giving rise to numerous papers in the Transactions of the Illuminating Engineering Society and articles in the technical press dealing with the principles of optics, searchlighting for military and navigation purposes, flood-light projectors for displaying surfaces at a distance, headlighting for vehicles, orientation lighting for the navigator, light signals, and apparatus for the projection of enlargements of transparencies.

Two general classes of apparatus are used to direct the flux from a source into the desired small angle: Opaque reflector systems controlling the light by the principle of specular reflection, and lens systems depending upon the refractive properties of glass. Frequently the two forms of control are combined in the same device.

In Fig. 1, *A*, is illustrated the action of a simple convex lens. A light ray emerging from the focus, *F*, is refracted in passing through the lens so as to be projected parallel with the axis, while from a larger source as shown at the focus, a cone of light is projected with an angle of divergence,  $2b$ , depending upon the size of the source, the focal length of the lens and the angle,  $a$ , at which it is emitted. The greatest angle of divergence is that of the cone issuing at the axis of the lens. These statements apply to lenses intercepting the flux in a relatively small solid angle. As the diameter of a lens increases relative to the focal length, the thickness, and hence the absorption, increase rapidly and the control of the emerging rays is limited by the increasing spherical and chromatic aberration. To

reduce these elements of inefficiency, Fresnel nearly one hundred years ago built a lens of concentric rings, Fig. 1, *B*; in effect a large convex lens with sections of the glass removed. He also added concentric prism rings to direct additional light into the beam by total reflection. Later these prisms were given a curved surface and re-

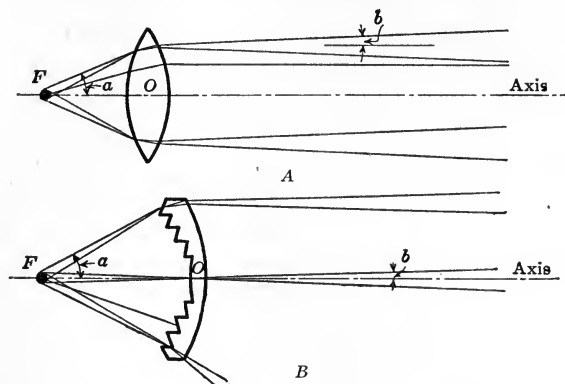

Fig. 1.—Light projection with lenses.

fraction was combined with reflection to produce the desired results. It will be noted that the sections give rise to a series of dark rings when viewed within the beam, since the light striking the risers is deflected at a large angle from the axis. In Fresnel lenses of reason-

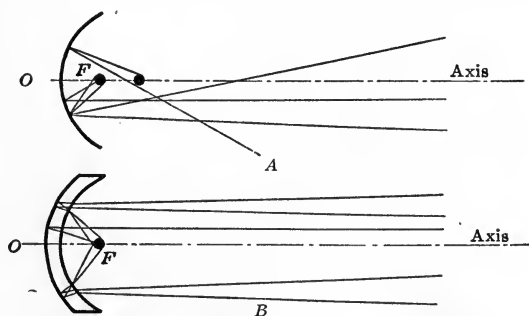

Fig. 2.—Light projection with opaque reflectors.

ably effective angle, the solid angle subtended by the lens at the focus, the contour of the surface may be so corrected as to secure very accurate control of light. They are frequently referred to as stepped or as corrugated lenses.

Rays emerging from a source at the center of a sphere are reflected from the polished surface as shown in Fig. 2, *A*. Used in this manner

as an accessory with a lens on the other side of the source, the mirror increases the amount of light intercepted by the lens, providing the source is at least partially transparent. With the source placed on the axis of a spherical mirror at half the radius, rays are returned with only a small divergence from the parallel when the effective angle is not large. Mangin devised a spherical mirror of silvered glass with the radius of the inner surface less than that of the outer, Fig. 2, *B*. The varying degree of refraction introduced by this concavo-convex lens is utilized to keep the divergence of the beam within narrow limits for effective angles up to as much as  $120^\circ$ .

The greatest efficiency and accuracy in concentrating light with an opaque reflector is secured with a parabolic contour, since all rays from the focus are reflected parallel with the axis no matter

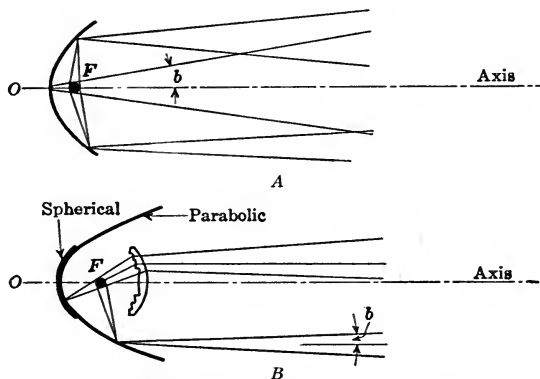

Fig. 3.—Light projection with opaque reflectors.

how large the effective angle is made. The divergence from a source as in Fig. 3, *A*, is greatest at the axis and decreases with increasing angles. Only within the angle of the cone showing the smallest divergence, that is the cone emanating from the edge of the mirror, does the beam contain light from all parts of the surface, and hence only in this region does the measured candle-power obey the inverse-square law. Beyond this limiting cone, light is received from a decreasing zone of the reflector until at the edge of the cone only the point at the axis is effective. Fig. 3, *B*, shows one combination of reflecting surfaces and lens among several that may be employed to meet various requirements.

In all of the projection devices described above a part of the beam receives light from the entire surface. In some cases this is at the axis only; in others, over a wider angle. The brightness of the sur-



face is in every case the brightness of the source at the respective angle multiplied by the coefficient of reflection or transmission of the system. The intensity of the beam within this range is, therefore, the product of the brightness and the projected area of the surface; variations in the focal length and the effective angle do not change the result. The multiplying factor of the system is then approximately the ratio of the squares of the diameter of the mirror and the diameter of the source. Table I, giving the brightness of the various sources used in projection apparatus, indicates their relative value so far as the production of the maximum beam intensities is concerned.

In most applications a beam can advantageously be utilized with a divergence so great that the total amount of flux in the beam is of equal or greater importance than the central density. The effective angle of the system, the size of the source and the focal length are important factors in determining the width of the beam, the total flux and its distribution. Table II gives the solid angles subtended at the focus by parabolic reflectors and lenses of various proportions. The latter are most often applied where accuracy of control is required; the former where it is desired to intercept the flux in a relatively large solid angle. The average opaque projector system directs from 30 to 60 per cent. of the available light into the beam; with lens systems, typical effective angles are so small that only 5 to 10 per cent. is transmitted. The cost of the respective types of apparatus for different sizes is, of course, often the determining factor in their adoption; in general the cost of lenses increases the more rapidly with larger size.

TABLE I.—INTRINSIC BRILLIANCY OF COMMON PROJECTION SOURCES

Source	Candle-power per sq. inch
Flame Arc for search lighting.....	250,000-350,000
Carbon Arc " " ".....	80,000- 90,000
Magnetite Arc.....	4,000- 6,000
Mazda C Projection Type.....	9,000- 18,000
Mazda C Regular.....	3,500
Mazda B Concentrated.....	1,200
Mazda B Regular.....	750
Kerosene Mantle.....	200-500
Acetylene.....	60
Gas Mantle.....	30-50
Kerosene Flame.....	5-10

TABLE II.—PERCENTAGE OF TOTAL SOLID ANGLE SUBTENDED BY PARABOLIC REFLECTORS AND CONDENSING LENSES

Parabolic reflectors		Condensing lenses	
Ratio of diameter of opening to focal length (R)	Percentage of total solid angle	Ratio of diameter to focal length (R)	Percentage of total solid angle
2	20.0	0.3	0.6
3	36.0	0.4	1.0
4	50.0	0.5	1.5
5	61.0	0.6	2.1
6	69.2	0.7	2.8
7	75.4	0.8	3.6
8	80.0	0.9	4.4
9	83.5	1.0	5.3
10	86.2	1.1	6.2
		1.2	7.1
		1.3	8.1
		1.4	9.1
		1.5	10.0
		2.0	14.6
		2.5	19.1

Percentage of Total Solid Angle	Percentage of Total Solid Angle
$= \frac{\cos \frac{\theta}{2} + 1}{2} \times 100$	$= \left( \frac{1 - \cos \frac{\theta}{2}}{2} \right) \times 100$
$= \frac{R^2}{R^2 + 16} \times 100$	$= \left( 0.5 - \frac{1}{\sqrt{4 + R^2}} \right) \times 100$

There are four principal surfaces employed in opaque projectors. Those of mirrored glass and silvered metal have a coefficient of reflection of the order of 85 per cent. Polished aluminum reflects slightly more than 60 per cent. of the incident light, and a nickel-plated brass surface has an efficiency of less than 55 per cent. All of the metal surfaces tarnish and require repolishing or replating from time to time. Silvered metal deteriorates rapidly where air circulates over it, particularly in a salt atmosphere and where fumes from stacks are present. The nicked and aluminum surfaces depreciate less rapidly. The aluminum has the further advantage that repolishing does not also in time involve replating as with the other metal units. Silvered glass is usually found the most desirable and economical in the long run, although where there is no intense heating and the reflectors may be tightly enclosed, silvered metal is found very satisfactory. The light absorption by lenses varies with the thickness of the glass and the nature of the construction; 10 to 15 per

cent. may be taken as typical values. With Fresnel lenses there is a further loss due to the rings produced by the risers.

The large proportion of the projection field served by the parabolic reflector makes a further analysis of its properties with different sources desirable. The following curves, Figs. 4, 5, and 6, and accompanying formulæ are taken from Benford's paper<sup>1</sup> on this subject. In Fig. 4 are shown the beam characteristics that are approached as the source approaches a point radiating equally in all directions. The rays are parallel and the apparent candle-power is,

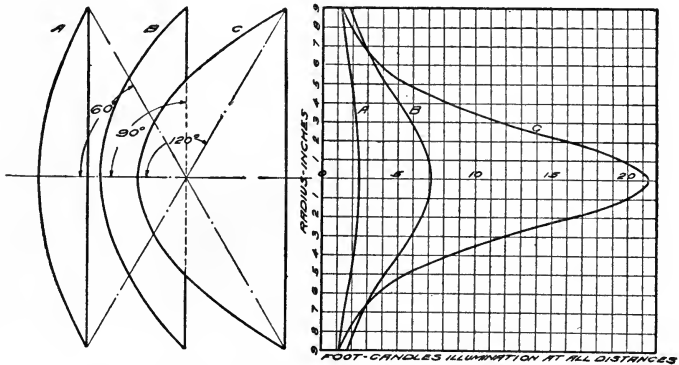

Fig. 4.—Parabolic mirror and point source beam characteristics.

of course, different at each distance measured. The density of the flux at any radius is given<sup>2</sup> by the formula,  $D = \frac{mI}{F + \frac{R^2}{4F}}$ . The

results are shown for three reflectors of equal diameter but of different focal length and effective angle.

In Fig. 5 a similar analysis is made for a spherical source of 0.5 in. diameter and a brilliancy of 1000 c.p. per sq. in. In this case the equation for the axial density of the beam becomes

$$E = \frac{4\pi mIF^2}{sL^2} \tan^2 \frac{1}{2}a_1 = \frac{\pi mBR^2}{L^2}.$$

Hence

$$I_B = \pi R^2 Bm.$$

<sup>1</sup> Frank A. Benford, Jr., "The Parabolic Mirror," Trans. I. E. S., Vol. X, page 905.

<sup>2</sup> The following symbols are employed:  $E$  = illumination on a plane normal to beam, in foot-candles;  $I_a$  = intensity of source at angle  $a$  from axis of mirror, in candles;  $I_B$  = intensity of beam, in candles;  $B$  = brilliancy of light source, in candles per sq. in.;  $m$  = coefficient of reflection of mirror;  $F$  = focal length of mirror, in inches;  $R$  = radius of mirror, in inches;  $L$  = distance from focal point to point in beam, in feet;  $r$  = radius of source, in inches;  $s$  = area of light source, in sq. in.;  $a$  = angle measured about focus, in degrees.

The intensity varies, for fixed focal length, with the square of the tangent of one-fourth the effective angle; for fixed angle, as the square of the focal length. Also, the axial intensity is seen to depend upon the brightness of the source but is not affected by its size; it is

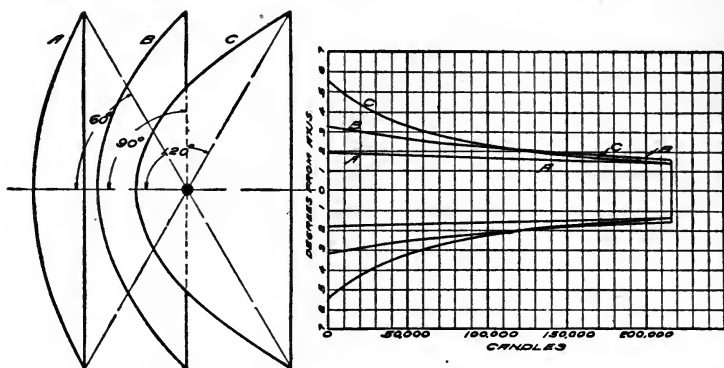

Fig. 5.—Parabolic mirror and spherical source beam characteristics.

equal for all parabolic mirrors having the same diameter. The same intensity will be directed at all angles within which light is received from the entire surface of the reflector. This angular spread is determined by the size of the source and its angular radius viewed

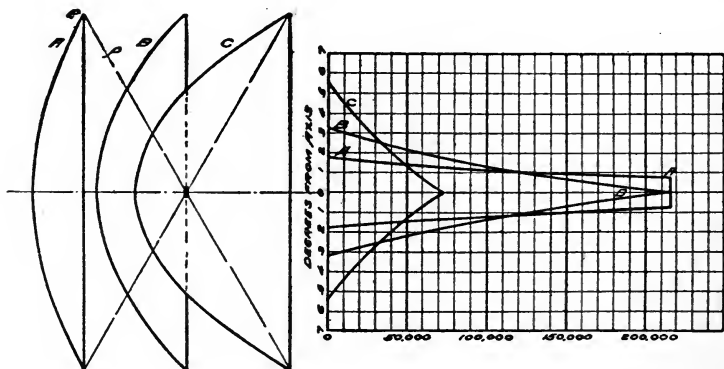

Fig. 6.—Parabolic mirror and disk source beam characteristics.

from the edge of the reflector. The intensity at other angles is proportional to the area of the mirror contributing light.

These characteristics of the beam apply at distances beyond the point at which the rays from the extreme edge of the reflector cross

the axis. This point of maximum density from which the inverse square law takes effect is found from the equation

$$L_o = \frac{R \left( F + \frac{R^2}{4F} \right)}{12r}$$

For a disk source the characteristics are given in Fig. 6. Here again  $IB = \pi R^2 Bm$ .

With a disk source a wider angular opening than  $180^\circ$  is not effective, since the projected area becomes zero at  $90^\circ$  from the axis. The effective diameter of reflector  $C$  is therefore reduced to  $2A$ . The distance from the focus at which the inverse square region begins is in this case

$$L_o = \frac{R \left( F + \frac{R^2}{4F} \right)}{12r \cos a}$$

#### EQUIPMENTS FOR VEHICLE HEADLIGHTING

The opaque projectors find by far their greatest application on vehicles; the number of automobiles, street and interurban railway cars, electric and steam locomotives equipped with projectors is, no doubt, in excess of 3,000,000 in the United States alone.

The first object in equipping automobiles with projectors was, of course, to light the road ahead for the driver. It is desirable that the driver of an automobile be able to see his way for several hundred feet in advance, and since he must provide his own lamps and direct the light unfavorably for lighting the roadway, it becomes necessary to project a high intensity. It was the effort to accomplish this, as well as to give ease of control, that brought about the rapid change from oil and acetylene units to the electric system employing closely coiled low-voltage filaments in deep projectors, giving both accurate control and high efficiency. The intensities now vary throughout a wide range up to hundreds of thousands of candle-power with an average of about 25,000. If there were but one automobile and a lonely road, the headlighting problem might be considered solved. But the higher intensity lighting equipments have, in solving the problem of lighting the road, introduced a new and serious problem in that they temporarily blind the driver or pedestrian who happens to come within their angle of action.

"Glare" is the one word most used in referring to the blinding

effect of high candle-power units. This question probably commands more widespread interest at the present time than any other problem within the scope of the illuminating engineer. A few states and many cities have enacted legislation designed to regulate the use of projector lamps to eliminate dangerous glare. Other states and cities have such laws in contemplation. In Table III is found a summary of the automobile laws of the various states as obtained in response to a general letter sent to the Secretaries of State under date of June, 1916. It is seen that a small percentage have laws pertaining to glare, and that there seems to be lack of definiteness in the laws which do exist. It should be possible with more general knowledge as to the causes of glare and with a more widespread understanding of the methods of measuring light, to create laws which will be definite, consistent with a consideration of the factors involved, and stated in terms which permit of verification by measurement.

It is generally agreed that the main factors involved in producing glare are included in the following:

1. Luminosity of background.
2. Solid angle subtended by source projected area at eye of observer; in other words, source size and distance.
3. Luminous intensity of source in direction in question.

Automobile headlighting units are limited by cost and appearance considerations to sizes under 1 ft. in diameter, and the size can be considered as a constant in a consideration of the glare problem. The luminosity of the background under worst conditions is zero, the complete darkness of the country road, and it is likely to be for some time, until all roads are artificially illuminated at night. Therefore, the third factor, the luminosity of the background, is also a constant so far as the present problem is concerned. There remains then only one controllable factor, the luminous intensity.

There is likely to be a great difference of opinion as to the limit of intensity which would be fairly safe and yet endurable. An intensity of 100,000 candle-power is unquestionably bad, and there is hardly an appreciable reduction in the glare in cutting down to 10,000 candle-power, assuming, of course, the worst background conditions. It is unfortunate that no consistent method has been devised for the measurement of interference with vision, making it possible to determine the relation between glare effect and candle-power for some fixed road condition. Observations have indicated that such a curve taken on a dark country road would be of the general form of Fig. 7.

TABLE IIIA

AUTOMOBILE HEADLIGHTING REGULATIONS							
STATE	DATE OF LATEST LAW	LAMPS REQUIRED	DISTANCE VISIBLE	TAIL LIGHT	MOTORCYCLE LAMPS REQUIRED	TIME OF BURNING IN TERMS OF HOURS AFTER SUNSET AND BEFORE SUNRISE	NON-GLARE REGULATIONS BRIEF STATEMENT
ALABAMA	1911	2	NOT STATED	YES	2°	½ AFTER - ½ BEFORE	NONE
ALASKA TERRITORY	No Law						
ARIZONA	1913	2	REASONABLE DISTANCE	YES	1	1 AFTER - 1 BEFORE	NONE
ARKANSAS	1913	2	200 FEET	YES	NO	SUNSET - 1 BEFORE	NONE
CALIFORNIA	1915	2	500 FEET	YES	1	½ AFTER - ½ BEFORE	NONE
COLORADO	1913	2	NOT STATED	YES	1	SUNSET - SUNRISE	NONE
CONNECTICUT	1915	2	200 FEET	YES	1	½ AFTER - ½ BEFORE	NONE
DELEWARE	1915-16	1	200 FEET	YES	1	1 AFTER - 1 BEFORE	MUST NOT BLIND PERSONS IN STREETS, WALKS
DIST OF COLUMBIA	1916		200 FT., FRONT, SIDES, REAR	YES	1	½ AFTER - ½ BEFORE	NONE
FLORIDA		2	NOT STATED	NO	2°	SUNSET - SUNRISE	NONE
GEORGIA	1916	2	REASONABLE DISTANCE	YES	1	1 AFTER - 1 BEFORE	NONE
IDAHO	1915-16	2	200 FEET	YES	1	1 AFTER - 1 BEFORE	NONE
ILLINOIS	1916	2	200 FEET	YES	1	SUNSET - 1 BEFORE	NONE
INDIANA	1913	2	200 FEET	YES		½ AFTER - ½ BEFORE	NONE
IOWA	1915	2	500 FEET	YES	1	½ AFTER - ½ BEFORE	NONE
KANSAS	1913	1	REASONABLE DISTANCE	YES	1	½ AFTER - ½ BEFORE	NONE
KENTUCKY	1914	2	200 FEET	YES	1	SUNSET - 1 BEFORE	NONE
LOUISIANA	1915*						
MAINE	1915	2	NOT STATED	YES	1	½ AFTER - ½ BEFORE	NONE
MARYLAND	1916	2	200 FEET	YES	1	½ AFTER - ½ BEFORE	MAXIMUM C.P. OF LIGHT = 30 C.P.
MASSACHUSETTS	1916	2	200 FEET	YES	1	1 AFTER - 1 BEFORE	AT 50 FT. NO GLARE HIGHER THAN 3½ ABOVE GROUND
MICHIGAN	1916	1	200 FEET	YES	1	1 AFTER - 1 BEFORE	MUST NOT BLIND DRIVER OF APPROACHING VEHICLE
MINNESOTA	1915	2	200 FEET	YES		1 AFTER - 1 BEFORE	NONE
MISSISSIPPI	1916	2	200 FEET	YES	2°	½ AFTER - ½ BEFORE	NONE
MISOURI		2	200 FEET	YES	2°	½ AFTER - ½ BEFORE	NONE
MONTANA	1913	2	200 FEET	YES	2°	1 AFTER - 1 BEFORE	NONE
NEBRASKA	1915	1	REASONABLE DISTANCE	YES	1	1 AFTER - 1 BEFORE	NONE
NEVADA	1916	2	REASONABLE DISTANCE	YES	1	1 AFTER - 1 BEFORE	NONE
NEW HAMPSHIRE	1916	2	200 FEET	YES		½ AFTER - ½ BEFORE	DIM WHEN APPROACHING AUTOS OR STREET CARS
NEW JERSEY	1916	2	250 FEET	YES	1	½ AFTER - ½ BEFORE	NO GLARE HIGHER THAN PARALLEL 4½ FT ABOVE ROAD
NEW MEXICO TERR	1913	2	NOT STATED	YES		1 AFTER - 1 BEFORE	NONE
NEW YORK	1916	2	200 FEET	YES	2°	½ AFTER - ½ BEFORE	NONE
NO. CAROLINA	1913	2	NOT STATED	YES	1	½ AFTER - ½ BEFORE	NONE
NO. DAKOTA	1915	2	NOT STATED	NO	1	NOT STATED	NONE
OHIO	1915	2	200 FEET	YES	1	½ AFTER - ½ BEFORE	NONE
OKLAHOMA	1916*						
OREGON	1915	2	200 FEET	YES	1	1 AFTER - 1 BEFORE	NONE
PENNSYLVANIA	1913	2	200 FEET	NO	1	1 AFTER - 1 BEFORE	NONE
RHODE ISLAND	1916	2	200 FEET	YES	NO	NOT STATED	NONE
SO. CAROLINA							
SO. DAKOTA	1913	2	NOT STATED	YES	1	½ AFTER - ½ BEFORE	NONE
TENNESSEE	1915*						
TEXAS	NO LAW						
UTAH	1915	2	REASONABLE DISTANCE	YES	2	1 AFTER - 1 BEFORE	NONE
VERMONT	1916	2	200 FEET	YES	1	¾ AFTER - ¾ BEFORE	NONE
VIRGINIA	1916	1	100 FEET	YES	1	1 AFTER - 1 BEFORE	NONE
WASHINGTON	1915	2	200 FEET	YES	1	HOURS OF DARKNESS	NONE
WEST VIRGINIA	1915	2	REASONABLE DISTANCE	YES	2°	1 AFTER - 1 BEFORE	NONE
WISCONSIN	1915	1	REASONABLY BRIGHT	YES	1	½ AFTER - ½ BEFORE	NONE
WYOMING	1913	1		YES	1	1 AFTER - 1 BEFORE	NONE

\* REGISTRATION AND OPERATION LAWS ONLY

° LAW ASSUMED TO APPLY TO BOTH AUTOS AND MOTORCYCLES

If the background is entirely dark, as often occurs in country driving, there seems to be interference with vision even with the lowest intensity dimmed light sources. In reducing the intensity,

TABLE IIIB

LOCOMOTIVE HEADLIGHTING REGULATIONS					
STATE	DATE OF LATEST LAW	BRIEF STATEMENT OF LOCOMOTIVE HEADLIGHTING LAW	FIRE OF BURNING IN TERMS OF HOURS AFTER SUNSET AND BEFORE SUNRISE.	EXCEPTING TO OPERATING IN THE EVENING E.T.C.	PENALTY FOR VIOLATION
ALABAMA	1915	1500 CP MEASURED WITH AID OF REFLECTOR	NOT STATED	NOT STATED	NOT STATED
ALASKA TERRITORY	NO LAW				
ARIZONA	1912	1500 CP MEASURED WITHOUT AID OF REFLECTOR	NOT STATED	YES	\$100-\$1000
ARKANSAS	1913	1500 C.P.			
CALIFORNIA	1913	SUFFICIENT TO DISTINGUISH DARK OBJECT SIZE OF MAN AT 800 FT., TRAIN RUNNING 30 MPH OR MORE			
COLORADO	1914	1200 CP MEASURED WITHOUT AID OF REFLECTOR			
CONNECTICUT	NO LAW				
DELEWARE	NO LAW				
DIST. OF COLUMBIA	⊕				
FLORIDA	1913	1500 C.P.			
GEORGIA		MUST CONSUME 300 WATTS AT ARC.- 23 REFL.			
IDAHO	⊕				
ILLINOIS	1913	SUFFICIENT CP WITH REFLECTOR TO DISCERN OBJECT SIZE OF MAN AT DISTANCE 800 FT.	SUNSET-SUNRISE	YES	\$100-\$500
INDIANA		1500 C.P.			
IOWA	1913	SUFFICIENT TO DISTINGUISH OBJECT SIZE OF MAN LYING PRONE ON TRACK AT DISTANCE 1100 FEET			
KANSAS		SUFFICIENT CP WITH REFLECTOR TO DISCERN OBJECT SIZE OF MAN AT DISTANCE 800 FT			
KENTUCKY	⊕				
LOUISIANA	⊕				
MAINE	⊕				
MARYLAND	⊕				
MASSACHUSETTS	⊕				
MICHIGAN	1914	RENDER VISIBLE OBJECTS 350 FT AHEAD	NOT STATED	YES	\$100
MINNESOTA	1913	1500 CP MEASURED WITHOUT AID OF REFLECTOR	SUNSET-SUNRISE	YES	\$25-\$100
MISSISSIPPI		MUST CONSUME 300 WATTS AT ARC.- 18" REFL.			
MISSOURI	1914	1500 CP MEASURED WITH AID OF REFLECTOR			
MONTANA	1914	1500 CP MEASURED WITHOUT AID OF REFLECTOR			
NEBRASKA	1914	SUFFICIENT TO DISTINGUISH OBJECT SIZE OF MAN AT 600 FT BY PERSON OF NORMAL VISION			
NEVADA	1914	1500 CP MEASURED WITHOUT AID OF REFLECTOR			
NEW HAMPSHIRE	⊕				
NEW JERSEY	⊕				
NEW MEXICO TERR.	⊕				
NEW YORK	⊕				
NO. CAROLINA		1500 CP MEASURED WITHOUT AID OF REFLECTOR			
NO. DAKOTA	1914	1200 CP MEASURED WITHOUT AID OF REFLECTOR	SUNSET-SUNRISE	YES	\$100
OHIO	⊕				
OKLAHOMA	1916	1500 CP MEASURED WITHOUT AID OF REFLECTOR	SUNSET-SUNRISE	YES	\$100-\$1000
OREGON	1914	SUFFICIENT CP WITH REFLECTOR TO DISCERN OBJECT SIZE OF MAN AT DISTANCE 800 FEET			
PENNSYLVANIA	⊕				
RHODE ISLAND	⊕				
SO. CAROLINA		16,000 CP WITH REFL. OR SUFFICIENT TO DISCERN OBJECT SIZE OF MAN AT DISTANCE 800 FEET			
SO. DAKOTA	1911	1500 CP MEASURED WITHOUT AID OF REFLECTOR	NOT STATED	YES	\$100-\$1000
TENNESSEE	⊕				
TEXAS	1907	1500 CP MEASURED WITHOUT AID OF REFLECTOR	SUNSET-SUNRISE	YES	\$100-\$1000
UTAH	⊕				
VERMONT	1915	2500 CP MEASURED WITH AID OF REFLECTOR			
VIRGINIA	1914	500 CP MEASURED WITH AID OF REFLECTOR	NOT STATED	YES	\$25-\$100
WASHINGTON	1909	DESIGN APPROVED BY R.R. OR PUB. SERV. COM.			
WEST VIRGINIA	NO LAW				
WISCONSIN	1913	SUFFICIENT CP WITH REFLECTOR TO DISCERN OBJECT SIZE OF MAN AT DISTANCE 800 FT.	AT NIGHTTIME	YES	\$100-\$500
WYOMING	NO LAW				

\* REG  
° LAW

⊕ NO REPLY TO INQUIRIES RECEIVED  
▼ DATA INCOMPLETE.

JULY 1, 1916

the glare vanishes completely only when the candle-power reaches zero. When the background is not dark, there can, of course, be considerable intensity without marked interference.



There are many devices on the market which reduce the glare by cutting down the intensity of the beam. They are diffusing doors of various forms and degree. As a rule, they slightly reduce interference at the maximum glare angle by diminishing beam candle-power to a small fraction of the previous value, and increase hundreds of times the solid angle in which glare is experienced. A well-focused, accurately made parabolic headlighting unit may produce blinding glare in the angle of the beam, but it has the one inherent virtue that except for the filament itself, its field of action is limited within a small angle. The approaching driver may face the beam at a considerable distance, but it likely to escape it when within, say,

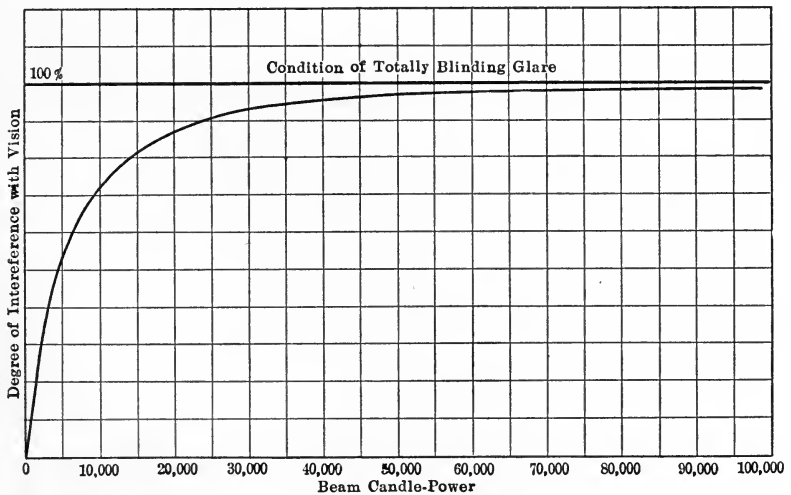

Fig. 7.—Nature of relation between beam candle-power and visibility of objects viewed against beam where the background is totally dark.

100 ft. of the approaching car. There is no escape from the diffusing equipment. One is like the small-pox, serious when encountered but not difficult to avoid; the other like the measles, not so serious, but unavoidable, it seems. If one of these diseases could be eliminated, many would vote that the measles should go. Fig. 8 illustrates light distribution from three typical classes of equipment; an unmodified parabola with covers of clear glass, partially frosted "lens" and all-frosted diffusing glass.

If the one object in regulation were to eliminate glare, the answer would be simple: Eliminate the concentrating headlights. Limits to the glare effect mainly protect the approaching driver; the problem

must be considered from the point of view of the driver behind the headlights as well. There are also pedestrians and the occupants of unlighted vehicles, whose safety depends upon the ability of the automobile driver to see them in sufficient time to avoid running them down. A just regulation should do more than place upper limits of permissible intensity; there should be lower limits in so far as road illumination is concerned. If the beams from automobile lamps are to be at all times capable of good road illumination and at the same

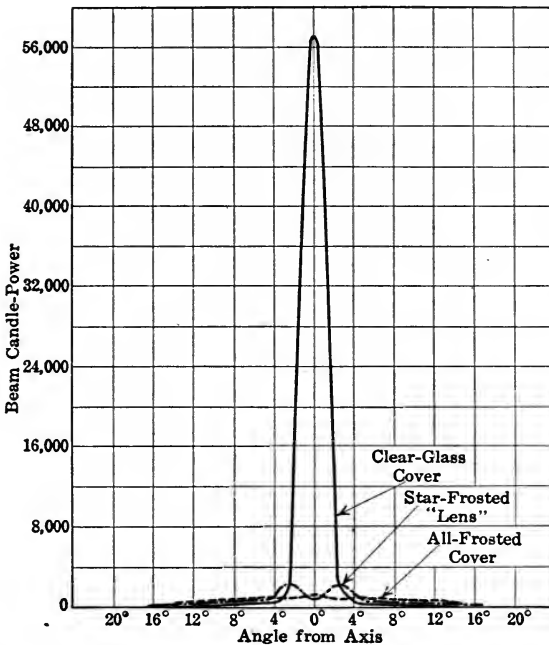

Fig. 8.—Beam candle-power of parabolic automobile projector with 6-8 volt, 3.0 ampere Mazda C lamp.

time incapable of causing glare under average conditions, there seems to be but one solution, and that is to greatly reduce or entirely eliminate the light from the angles above, say, 4 ft. from the ground, and retain the light at the lower angles.

Many devices have been designed for reducing or eliminating the upward light, redirecting the intercepted light in downward directions. The simplest method of eliminating strong upward light with accurately made headlamps is to tilt them downward by an angle equal to half the angle of spread of beam; many headlamps,

however, are not made sufficiently accurate to have any well-defined beam. Another method commonly used is to set the light source back of the focal point of the reflector and to cover the upper half of the door with an obscuring material. Obviously, this method is inefficient. The Patent Office records show a wide variety of devices for diverting the light from directions above the horizontal. One is a cup-shaped spherical reflector placed over the lamp bulb to return the upward light back along its initial path. When placed over the bulb, it is assumed that the filament is placed back of the focus. These devices are frequently seen placed on the lower side of the bulb, thus utilizing the upper instead of the lower half of the parabolic reflector, and when so used the filament must be forward of the focus in order to be effective. It not infrequently happens that the filament is in focus as adjusted by the owner, in which case the device has no effect except to reduce the efficiency of the lamp.

In another class of devices use is made of compound curvatures in the reflector. There is the offset parabola where the upper half has a focal point back of that of the lower half, so that the filament may be placed back of the focus of the lower half at the same time that it is placed forward of the focus of the upper half. A tilted upper half, where the upper surface has been revolved downward about the focus as a center, is another device described. Still another is a combination consisting of a parabolic lower part and an ellipsoidal upper part. This device if perfectly made would give no light above the horizontal, not even the direct light from the filament. Proper adjustment requires that the filament be placed a little more than half its axial length back of the focus of the parabolic part. The ellipsoid is arranged to have one of its foci at the proper position of the filament and the other, through which the intercepted rays are directed, at a point on the axis of the lamp within the plane of the front glass. There are also a number of prismatic glass covers that reduce the upward light, bending the reflected rays downward and to the side of the road. These devices seem to be limited in the degree to which they can cut down upward intensities, because in being designed to take care of the light coming from the reflector, they are sure to throw some of the direct light from the filament upward in narrow high-intensity beams, although this may be obviated by screening the tip of the bulb. Figs. 9, 10 and 11 are photographs by C. A. B. Halvorson, Jr., of a screen illuminated at a distance of 10 ft. by three types of equipment, star frosted, prismatic and paraboloid-ellipsoid.



Fig. 9.—Screen illuminated at 10 ft. by parabolic reflector with star frosted "lens."

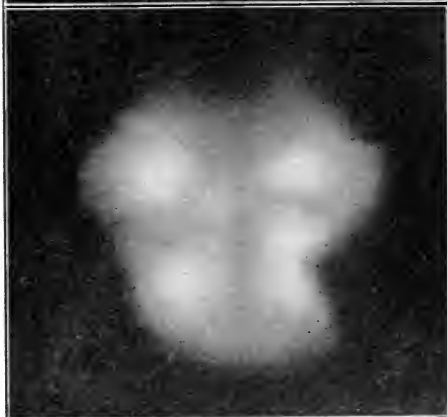

Fig. 10.—Screen illuminated at 10 ft. by parabolic reflector with prismatic cover.



Fig. 11.—Screen illuminated at 10 ft. by paraboloid - ellipsoidal reflector with clear glass cover.



No one of the so-called non-glare devices that are now in general use can be said to be a complete solution of the problem. Each may have its favorable point or points, just as the unmodified parabolic lamp has its advantage. An equipment which gives no light above the horizontal, may give good road surface illumination at the same time that it is incapable of glare on a dark road, but it can blind the approaching driver coming up into view on a convexity in the road, and has the further disadvantage that it ordinarily must show up vehicles and other objects by their lower extremities only and may miss entirely the near objects when approaching the foot of a hill. A lamp with no light above the horizontal is sure, on account of the varying curvatures in road profile, to have a widely varying range of throw. From the driver's standpoint it has great advantage in a fog since there is none of the usual luminous haze between the driver's eyes and the road.

The details of the various devices which have appeared are interesting but they are not as important at the present time as the study of the underlying principles. If the best solution to the problem were a matter of general agreement, a device which would accomplish the result would probably soon appear. As a matter of fact, some of those already on the market give results which the inventors believe to be the best solution. Some of the states have evidently assumed that it is necessary only to place upper limits of intensity above 3 or 4 ft. from a level road; presumably it is considered unnecessary to place lower limits of intensity for lower angles. Assuming that the best answer to the glare problem is the elimination of light above the horizontal, it should be possible to draught a regulation which would be definite and in terms capable of measurement. It would be necessary to use only one technical term. Such a law might specify that the head lighting beam shall not have an intensity at any angle above the horizontal exceeding a certain amount, say, 20 candle-power, and that it shall have not less than an average of, say, 10,000 candle-power measured at equal vertical angular increments from the axis down to the road, at a distance of 100 ft. If desirable, lower limits of intensity at the lower angles to the side might be specified in order to insure that the driver can at all times see the curb or other sidewise limits to the road. The point to be emphasized is that once general agreement is obtained as to the best solution of the problem, the necessary regulations can be stated in simple terms involving only luminous intensity measurements in addition to simple measurements of length.

It may safely be said that the present tendency is toward cutting down or entirely eliminating the upward light, but it appears that this method in itself can never be entirely satisfactory to the motorist. Much of the pleasure and sense of security in night driving come from bringing into view the overhanging foliage and other high objects along the road, as is done with the usual parabolic units of high power. Evidently there is no harm done as long as there are no eyes ahead to be blinded. This feature may have prompted the recommendation of the glare committee of the Illuminating Engineering Society to the effect that unmodified parabolic equipments could be used if they were always extinguished when meeting another driver. This plan seems to have disadvantages, for on a dark road the sudden change is likely to interfere with the vision of both drivers due to the length of time required for adaptation, and, to an extent, greater than would be obtained with the glare of the undimmed lamps.

Perhaps the best solution is a regulation such as outlined above, but taken to apply only when meeting other vehicles on unlighted roads. Such a regulation would require on every automobile used at night an equipment giving no upward light, but would allow of any kind of additional equipment that might be desired. It would seem that an equipment consisting of one or two high-powered parabolic units with two lower-powered non-glare (no upward light) lamps would be satisfactory. The glareless lamps would be used for all night driving, both city and country, and the additional equipment of parabolic lamps could be employed at times when no harm would result to others.

Modification of the color quality of the light emitted from a headlamp is sometimes secured by means of yellow glass in the reflector or cover. Two advantages are sought by the suppression of the shorter wave lengths; increased acuity and decreased scattering of light. The former is seldom realized since the better acuity usually fails to compensate for the lower intensity. The latter effect is more often of importance since the rays scattered by a haze or fog produce a luminous veil that may seriously interfere with vision; an appreciable reduction of this veiling is obtained with the yellow glasses. The same purpose is served by the use of ordinary headlamps and a yellow disc on the wind-shield or yellow glasses worn by the driver. A further step in this direction has been attempted by making the reflector of glass with fluorescent properties and thus converting the shorter wave lengths instead of absorbing them.

The plan possesses little utility, however, since the transformed light is not projected into the beam by the reflector but issues as from a diffusely emitting medium.

### EQUIPMENTS FOR RAILWAY HEADLIGHTING

On street cars for ordinary city service, the head lamps need serve only as markers. For suburban and interurban runs with the higher speeds and dark roads, a higher intensity is required both

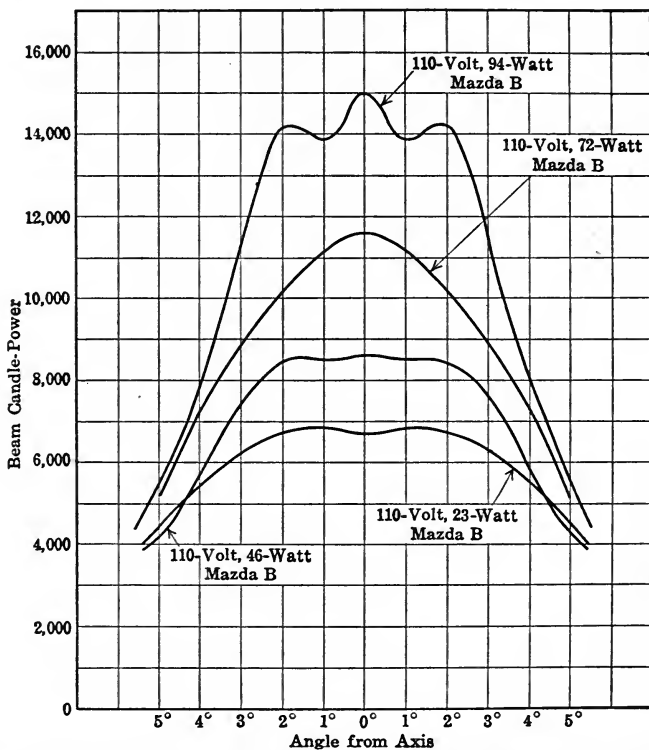

Fig. 12.—Beam candle-power of typical electric street railway head-lamp. Parabolic reflector of  $1\frac{1}{4}$  in. focus and  $8\frac{3}{8}$  in. diameter.

as a warning at greater distances of the approach of a car, and to illuminate objects on the track at a sufficient distance to allow the car to be stopped before reaching them. Fig. 12 gives photometric data for several lamps for headlighting typical of those used in this service. The advantage of the more concentrated low-voltage source in increasing the beam candle-power is apparent, but this greater



concentration is not always required. Since high-voltage direct current is available, the magnetite arc has been found to be particularly useful in this field when a high intensity beam is wanted. The large amount of steadying resistance stabilizes the arc, and when the equipment includes a lens cover, good control is secured, with the results shown in Fig. 13.

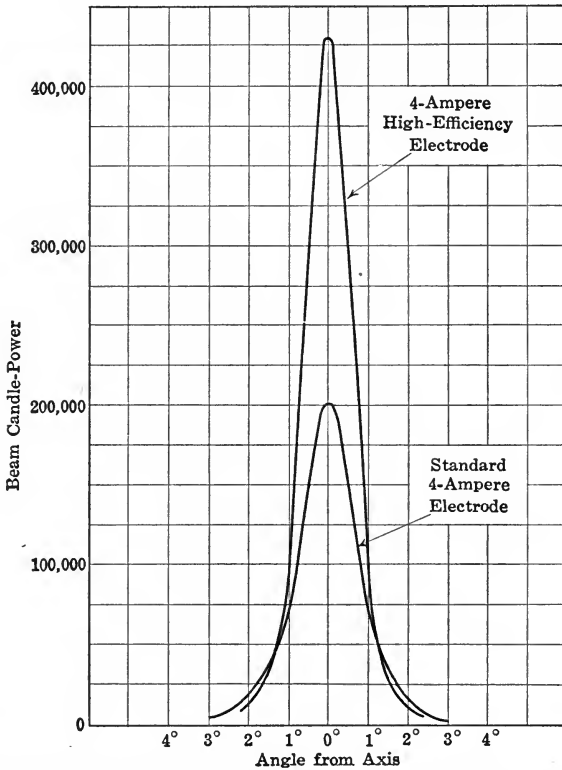

Fig. 13.—Beam candle-power of luminous arc interurban head-lamp with 12 in. semaphore lens.

The proper headlighting equipment for steam and electric locomotives has been exhaustively studied by railway associations, individual roads and utility commissions. The headlamp in this case may be made to serve as a marker for the head end of a train and as a warning of the approach of a train, for the illumination of wayside objects, for displaying numbers in the case and to enable the engineman to see objects on the track at a distance so great that he may stop the train before reaching them. All of these requirements

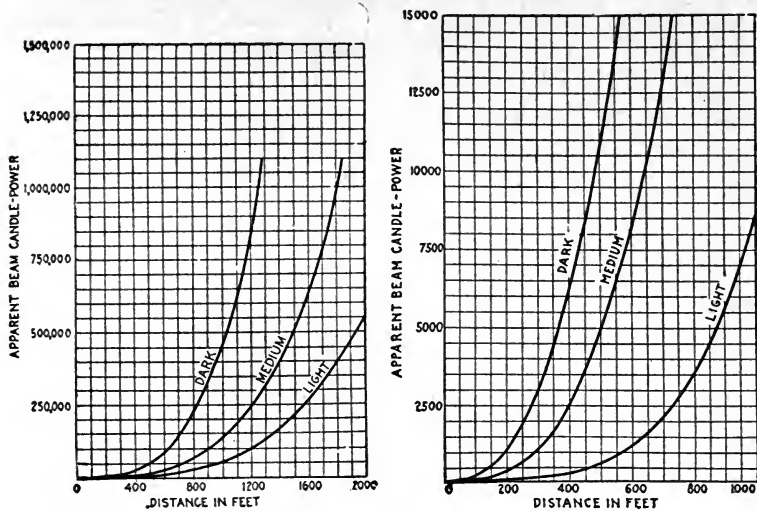

Fig. 14.—Locomotive beam intensities required to render dummies visible.

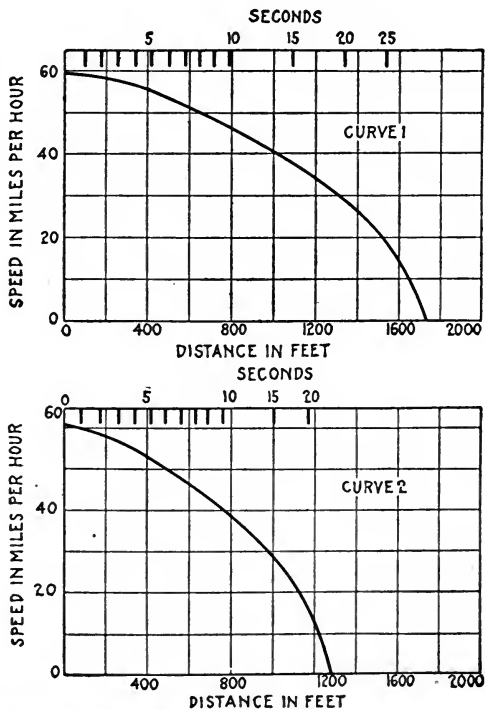

Fig. 15.—Deceleration curves for heavy express train with older and modern braking systems.

can probably be met with the best apparatus available at present, providing the brakes are applied immediately whenever any indication of an object on the track is seen. However, its use may lead to some difficulty in temporarily blinding a person passing through the beam and thus introducing an element of confusion at multiple track crossings, and in interfering with the visibility and correct reading

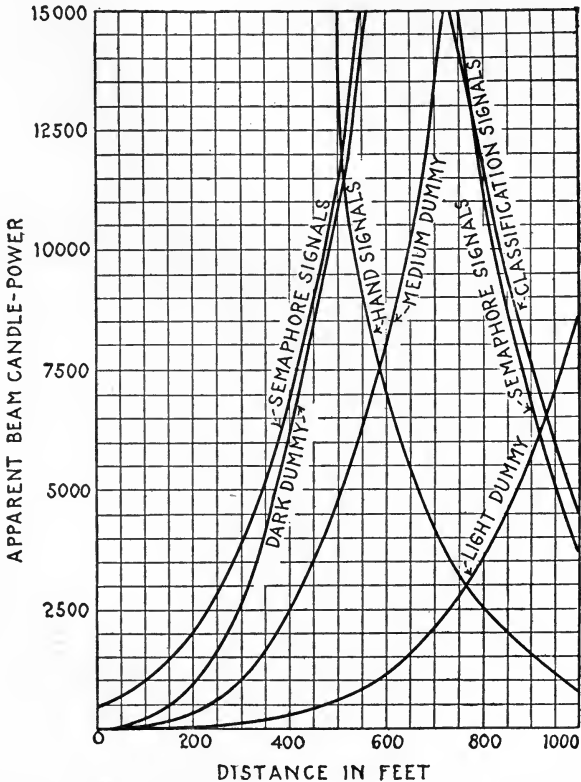

Fig. 16.—Visibility of signals and objects with various beam intensities.

of color and position of semaphore and hand signals, classification lights, etc.

From Minick's admirable summary<sup>3</sup> and presentation of the findings of the Headlight Committee of the Railway Master Mechanics Association and other investigators, covering the several classes of oil, acetylene, incandescent electric and arc lamps, are taken Figs. 14 to 17. Fig. 14 shows the beam intensity required to see

<sup>3</sup> J. L. Minick, "The Locomotive Headlight;" Trans. I. E. S., Vol. 9, page 909.

at different distances dummies of the size of a man dressed in light, medium and dark clothing. The curves at the left refer to the tests on the oil, acetylene and incandescent electric lamps; those on the right to the arc tests. There is a marked advantage in favor of the more yellow light sources due, no doubt, in part to the lack of steadiness in an arc and to the fact that there is a considerable proportion of blue rays for which the eye does not focus accurately; thus the visibility of a distant object is reduced with a given intensity of illumination. Fig. 15 shows deceleration curves for a heavy express train running at 60 miles per hour with both the older and more modern braking systems. It is evident that to stop the train

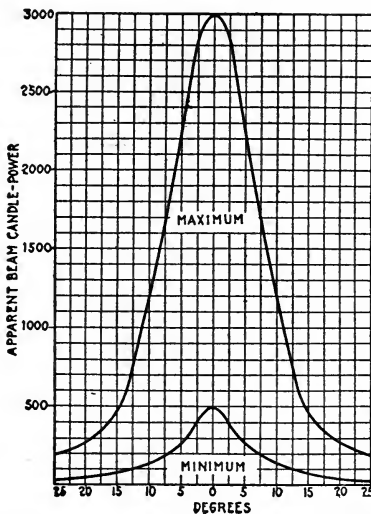

Fig. 17.—Candle-power specifications for locomotive head lamps recommended by Committee of Railway Master Mechanics Assn.

before reaching a detected object requires the use of exceedingly high beam candle-powers. From Fig. 16, recording the test data indicating the range within which the various signals may be identified without danger of error for different beam intensities, it would appear that only relatively low values of beam candle-power would meet the requirements from this standpoint with the prevailing signal sources. It is possible that the substitution of sources of higher intensity or greater concentration in the signals would make the use of high candle-power lamps satisfactory in every respect. The conclusion of the Master Mechanics Committee was that the intensity of locomotive headlights should fall

within the limits given in Fig. 17. These limits cover the range in which fall the oil and acetylene lamps with which most locomotives are still operated.

It would appear that the estimation of the relative importance of the several factors involved must determine the choice of headlighting characteristics. For multiple tracks and winding roads this will lead to different conclusions than for single-track roads without block signals. The Interstate Commerce Commission, which recently undertook the supervision of these devices used in interstate

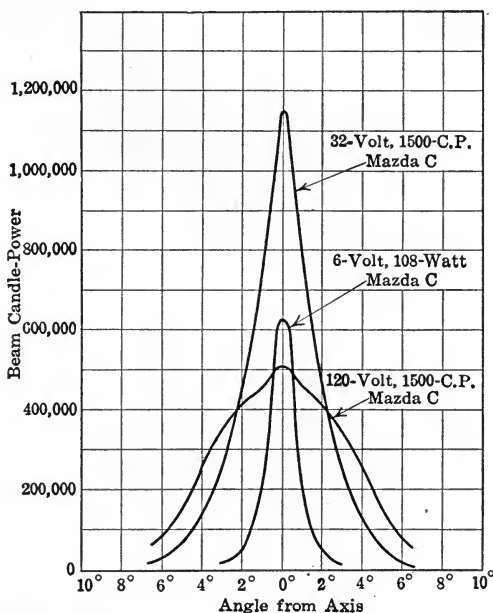

Fig. 18.—Distribution of light from incandescent headlight. Parabolic reflector of  $2\frac{3}{4}$ -in. focal length and 20 in. diameter.

traffic, ruled that after October 1, 1916, all new locomotives for road service and those given a general overhauling must be so equipped that a person of normal vision at the engine may be able to see a dark object of the size of a man at a distance of 1000 feet or more, under normal weather conditions. Furthermore, all locomotives must be so equipped before January 1, 1920. This is, of course, very different from the recommendations of the report above cited. As a result of the new ruling it would seem that electric units will be utilized in order to obtain the necessary intensity, and that since



Fig. 19.—Locomotive type incandescent head lamp.

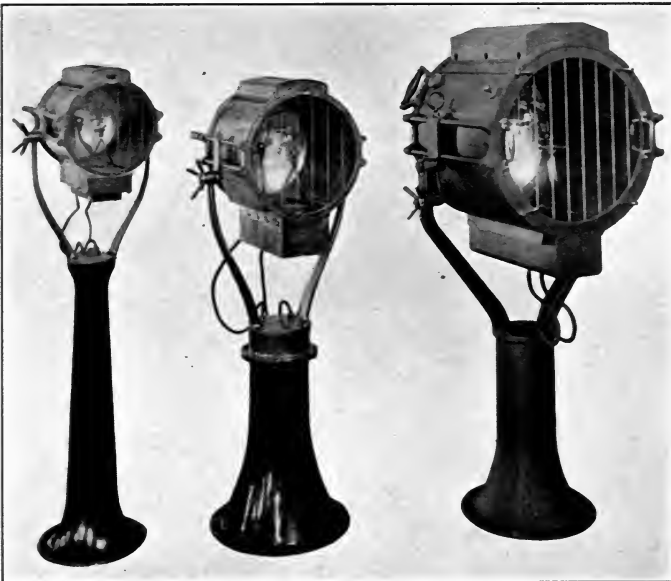

Fig. 20.—Hand-controlled commercial searchlighting equipments.  
(Facing page 234.)

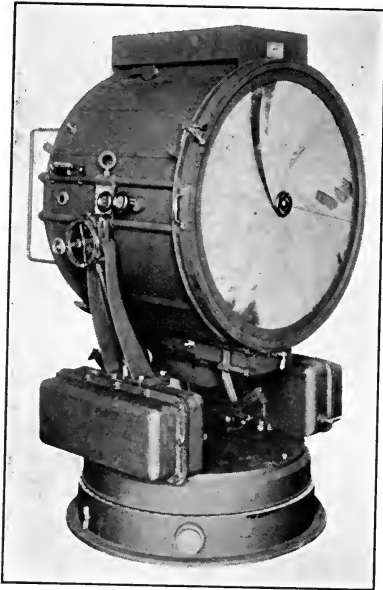

Fig. 21.

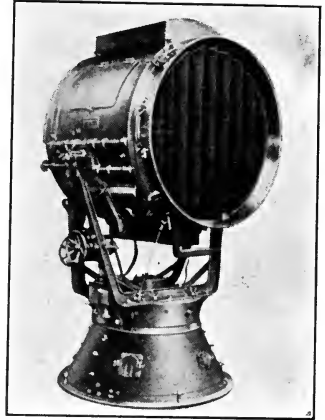

Fig. 22.



Fig. 23.

Figs. 21, 22, 23 — Military searchlights.

arc lamps have been found to possess less suitable characteristics and to be not so well adapted to the desirable electric systems in this service, incandescent lamps will be favored. The demand for mirrored glass reflectors may be expected to increase since the silvered metal parabolas which have been employed most in the past cannot so easily be maintained in the condition required.

It appears that the rulings of the commission can be met by the 36, 72 and 108-watt 6-volt gas-filled tungsten-filament lamps and the 150 and 250-watt 32-volt lamps. The 108-watt, 6-volt and 250-watt 32-volt provide a good factor of safety and will probably be most often employed. Fig. 19 illustrates one of the larger incandescent headlighting reflectors. In Fig. 18 are given the photometric results with three different lamps in this reflector. The folly of the headlighting legislation of a number of states (see Table III) requiring the use of a source of 1500 unreflected candle-power is apparent, since equal beam intensities may be secured with considerably reduced wattages. Requirements as to diameter, visual tests, etc., all are unnecessarily indefinite and lead to needless confusion. The entrance of the Interstate Commerce Commission into the field promises to relieve the chaotic condition resulting from the legislation of the individual states, but it would seem entirely feasible that its requirements be stated in the form of a specification of the beam characteristics and the method of measurement.

#### SEARCHLIGHTING EQUIPMENTS

Searchlighting equipments were developed principally for the military service. They have been employed by the army and navy for more than 50 years as one of the most effective means of defense against night attack, for locating enemy vessels and fortifications as well as for signaling purposes. About 30 years ago the first accurately ground parabolic mirrors became available and these with the direct-current carbon arc have been the standard equipment. No radical improvements in either the light source or optical system were made until recently, when the increasing range of torpedoes made these developments particularly desirable.

Fig. 20 shows a number of small hand-controlled searchlighting equipments such as are employed also in commercial work and in navigation. It will be seen that the electrodes are in a horizontal position, with the positive tip at the focus of the mirror inasmuch as most of the light is radiated from this surface. Fig. 21 is a mili-



tary equipment provided with automatic control and feeding mechanism. In addition to the clear glass front cover, there is an iris shutter for the purpose of quickly shutting off the beam or making it available at full candle-power; a considerable delay in securing full intensity would be involved if the arc were extinguished. In field operation the equipments are mounted on trucks with elevating platforms as shown in Fig. 22 and provided with reels of cable for connection with the energy supply. For rapid signaling Venetian blinds or louvers are used in front of the cover glass, Fig. 23.

Some data for typical equipments are given in Table IV:

TABLE IV.—TYPICAL CARBON-ARC SEARCHLIGHTING PROJECTORS

Nominal diameter of mirror in inches	Amperes	Actual diameter of mirror in inches	Focal length in inches	Reflector
9	10	.....	.....	Mangin Mirror
13	20	.....	.....	Mangin Mirror
18	35	$19\frac{3}{16}$	$7\frac{7}{8}$	Mangin Mirror
24	50	$25\frac{1}{8}$	10	Parabolic Mirror
30	80	$31\frac{3}{16}$	$12\frac{1}{4}$	Parabolic Mirror
36	110	37	$14\frac{3}{4}$	Parabolic Mirror
60	175	.....	.....	Parabolic Mirror

The 36-in. size has been standard in the navy, while the 60-in. size is used very generally in land fortifications. The beam intensity of such units is of the order of 60,000,000 and 200,000,000 candle-power, respectively. It will be noted that the focal length is in each case about 40 per cent. of the diameter, corresponding to an effective angle of  $120^\circ$  to  $130^\circ$ . Within this angle is included a large percentage of the light emitted by the arc; to increase the angle for a given diameter would be to decrease the beam intensity on account of the greater divergence resulting from the increased angle subtended by the source.

Since it is especially necessary to maintain the arc steady and at the focus of the reflector, very careful attention must be given to the electrical characteristics, the feeding mechanism, the uniformity of the electrodes, to secure constant rate of consumption, and a proper selection of sizes of electrodes. High current density and small crater result in high intrinsic brilliancy and beam intensity. The efficiency is increased as the diameter of the negative electrode is decreased and the arc lengthened, with the accompanying reduc-

tion in the angle of shadow. The small negative is also advantageous in steadying the arc; but if the current density is carried too high, the electrode spindles, that is, oxidizes near the tip and thus further reduces the diameter.

Chillas has reported the results of an investigation<sup>4</sup> which showed that by reducing the positive electrode size to the point where the arc crater covers practically the entire tip and using a small negative provided with a copper coating to increase the conductivity and prevent spindling, equilibrium conditions are attained more rapidly after starting, the arc is more steady, there is a higher average brightness of the positive, a smaller dispersion of the beam and hence a considerable increase in its intensity. These advantages are secured at a sacrifice of electrode life and with the necessity for some adjustment of the arc from time to time. The size of electrodes recommended is about  $1\frac{1}{8}$  in. positive and  $\frac{1}{2}$  in. negative in the 36-in. reflector, and for the 60-in.,  $1\frac{3}{8}$ -in. positive and  $\frac{5}{8}$ -in. negative. Heretofore a 2-in. positive has ordinarily been employed in the 60-in. lamp.

The recent developments in the application of flame electrodes at high current densities have produced a notable advance in the performance of searchlighting equipments. The electrode diameters are only about  $\frac{5}{8}$  in. for the positive and  $\frac{1}{16}$  in. for the negative. The arc is somewhat longer than with pure carbons and the negative electrode is inclined at an angle of about  $20^\circ$  below the axis. At the high currents employed, the luminous flame is confined in the deep crater of the positive, where the gases are superheated to an exceedingly high temperature, producing a brightness of about 350,000 candles per sq. in. The positive electrode is continually rotated and thus the crater kept symmetrical; the negative may also, with advantage, be rotated. At the high temperature involved, some provision must be made against spindling and for cooling the electrodes. In one form of lamp this is done by bathing the tips with burning alcohol vapor, which, with the radiating discs on the holder, acts as a cooling agent and prevents oxidation of the carbon shell. In another form, the holders are also provided with radiating discs which are cooled by a blast of air; the positive electrode is fed through a quartz tube to prevent spindling.

The Navy Department tests<sup>5</sup> have shown that in addition to its

<sup>4</sup> R. B. Chillas, Jr., "Operating Characteristics of Searchlight Carbons;" *Journal of the United States Artillery*, page 191, March-April, 1916.

<sup>5</sup> Lieut. C. A. McDowell, "Searchlights;" *Proc. A. I. E. E.*, Vol. 24, page 207.

higher efficiency of light production, the flame arc directs a greater percentage of the flux into the effective angle of the mirror. The small source results in a narrow angle of divergence—only  $1^\circ$  to  $2^\circ$ , as compared with  $2\frac{1}{2}^\circ$  to  $3^\circ$  for the beam from standard carbon arcs. In general, it is reported that these factors combine to produce with the flame arc units beam intensities about five times as great as those from standard carbon lamps.

The formula  $J_1 = \frac{J}{L^4} (1 - P)^{2L} K$ , giving the intensity reaching the observer from the object illuminated is frequently referred to as indicating that the range<sup>6</sup> of a beam is proportional to the fourth root of the intensity. On the other hand, it is contended by some that since the brightness of an object remains the same at all distances, that is, the luminous density on the retina is constant, visibility is dependent only upon the illumination of the object and that the range, therefore; varies with the square root of the beam intensity rather than the fourth root. For an object subtending a large angle this would doubtless be true, but it is still a moot question whether for small angles visibility is determined by the total flux or by the flux density. The factor of acuity doubtless is of the greatest importance. The dimensions of the object; the color, form and nature of its surface; the degree of contrast with surroundings; the influence of telescope, glasses or spectacles and the physiological peculiarities of the observer's eye all enter into the range at which a beam is effective. These factors have been analyzed by Blondel<sup>7</sup> who states that the range increases even less rapidly than the fourth root of the intensity. To multiply the range five fold under atmospheric conditions giving 70 per cent. transmission per kilometer, he estimates that the intensity would have to be increased 42,000 fold for typical military work.

The impression prevails that blue light is particularly desirable in the rays of a searchlighting beam since the surfaces observed are often bluish gray and because of the Purkinje effect. Whenever a preponderance of blue rays is reflected an advantage probably exists, but in the usual case it would seem to be detrimental since the eye will not focus for the blue rays when the longer wave lengths predominate, and vision is, therefore, impaired.

The present European war has brought about a number of inno-

<sup>6</sup> In this formula  $J_1$  = intensity directed toward eye of observer;  $J$  = intensity of searchlight beam;  $L$  = distances of illuminated object, observer assumed near searchlight;  $P$  = absorption of atmosphere;  $K$  = coefficient of reflection of object.

<sup>7</sup> Prof. A. Blondel, "A Method for Determining the Range of Searchlights;" *The Illuminating Engineer* (London), Vol. 8, page 85, 153.

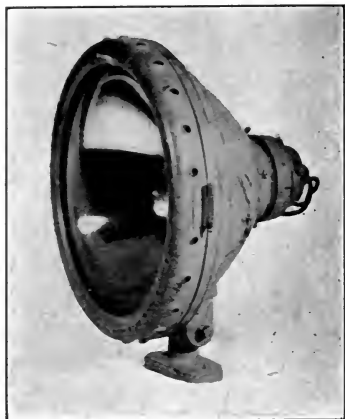

Fig. 24.



Fig. 25.



Fig. 26.



Fig. 27.

Figs. 24, 25, 26, 27.—Commercial flood-lighting projectors.

(Facing page 238.)



Fig. 28.—Representative flood-lighting installation.

vations in searchlighting equipments, such as the use of a Fresnel lens above the arc with units directed upward in anti-aircraft work, thus replacing a mirror below the arc, which would be subject to cracking by the molten carbon. For short ranges incandescent electric lamps with their steadier light, greater portability and ease of control, have been employed to advantage. Oxy-acetylene equipment has found similar application.

### FLOOD LIGHTING

Flood lighting of the exteriors of structures with sources concealed at a distance is more a problem of æsthetics than of optics.

Although arc projectors had been employed for temporary lighting spectacles of this nature, the general application was not found feasible until the concentrated tungsten-filament lamps of high efficiency were developed. With these units of relatively small size, the necessary flexibility in installation and control of intensity and direction were attained, so that artistic results might be secured. Flood lighting supplements the older forms of display illumination; it lends itself particularly to the fields of sculpture, monumental public buildings and commercial structures. It finds application also in the illumination of large outdoor spaces devoted to pageants or to sports, in the yards of industrial plants and railroads.

Desirable distributions of light for the majority of installations range from an angle of divergence of  $6^\circ$  to one of  $30^\circ$ . This is determined by the area of the surface, its distance from the units and the angle at which the beam is incident. A small amount of scattered light is usually not detrimental. The problem of reflector design is, therefore, one of securing high over-all efficiency and adjustment of beam spread rather than of narrow divergence and accurate control. Short focal lengths are, then, desirable so as to secure a large effective angle with a reasonable diameter and cost of reflector. It would seem that the tendency has been too general to secure spreading of the beam by placing the source out of focus in a parabolic reflector, which results in marked lack of uniformity in the spot. Except for the narrow beam units, the rational method is to proceed with the design of the reflector from the desired distribution curve and the limiting dimensions, just as with any other specular surface equipment. In this manner units are secured which not only produce a given spread with reasonable uniformity but,

by careful design, also permit a considerable adjustment of beam divergence.

Typical commercial flood-lighting projectors are shown in Figs. 24-27. All of these have reflectors of mirrored glass protected in various ways to withstand high temperatures and atmospheric conditions to which they may be subjected. A reflecting surface of this class is the only one to be recommended in the great majority of installations.

The projectors of Figs. 24 and 25 are designed for use with 250-watt flood-lighting lamps. In both cases the contour of the reflector departs somewhat from a parabola to give greater uniformity of beam with varying divergence as the position of the lamp is adjusted. The back part of the reflectors is spherical to accommodate the lamp bulb and direct the light back through the source, making possible a unit of short focal length and considerable depth, hence of high efficiency. The one unit is enclosed in a ventilated weatherproof housing with heat-resisting glass cover. The other has a similar cover but is tightly enclosed without a housing about the reflector; the copper backing provides the necessary strength and the dull black enameling facilitates radiation sufficiently to render ventilation unnecessary. Both units combine compactness and low cost.

Fig. 26 shows a unit usually employed with the 500-watt lamp. It is of parabolic contour, relatively more shallow but giving a more concentrated beam. For extreme concentration a reflector of this type is to be recommended with a 250-watt lamp. The projector of Fig. 27, designed for use with 1000-watt lamps, is a parabolic reflector that is shallow and hence inefficient in utilizing the flux; it is a desirable unit for few applications.

In Fig. 28 is given the distribution of candle-power from a typical 250-watt projector with the lamp in two positions. With the proper equipment it is usually possible to deliver from 30 to 50 per cent. of the total flux from the lamp on the surface of the structure to be illuminated. An experience of several years in flood lighting has demonstrated that a unit of the general type of Fig. 24 or 25 can most often be used advantageously and efficiently. The higher efficiency of the larger sizes of lamps favor their use, but the better control of direction and intensity with the smaller units frequently out-weighs this. It is desirable always to have every part of the surface receive light from several projectors in order to eliminate the striations (images of the filament) and to provide against apparent lack of intensity at any point when individual lamps burn out.

The intensity need by no means be made equal for all parts of a structure; rather, the brightness should be so distributed as to display the structure as nearly as possible as the architect or sculptor intended. Frequently certain features can be emphasized with advantage over the results secured with daylight. In general, desirable average intensities are dictated by the reflecting characteristics of the building in both amount and direction, the brightness of surroundings, the average distance from which it is to be viewed and maximum radius of visibility desired, as well as nature of the structure itself. There is seldom danger of overlighting if the installation is properly made.

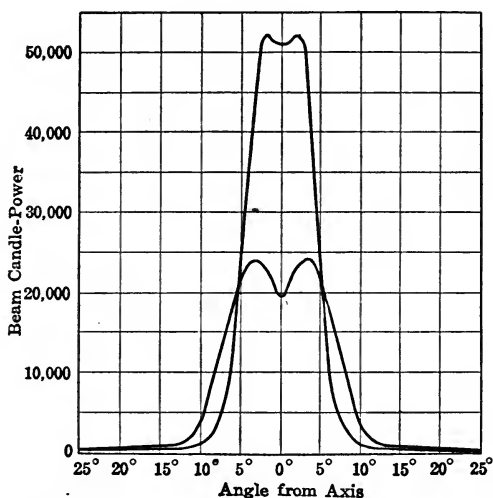

Fig. 29.—Beam candle-power of typical complete flood-lighting unit with 250-watt Mazda C flood-lighting lamp in two positions.

The latitude in direction of light and intensities employed may be indicated by reference to a few representative installations. Fig. 28 is a structure of simple Doric form in light Bedford stone and granite. Considerable choice is here offered both in the size of units and their location. The projectors are placed on the roof of a four-story building diagonally across the street and the electrical power provided is slightly more than  $\frac{1}{2}$  watt per square foot of building surface.

The granite building of Fig. 30 with its massive Corinthian columns and decorations in relief, required particular attention from the standpoint of direction. The light sources are placed



across the street and slightly higher than the bank building. About 1 watt per square foot is provided, and 250-watt units are employed in order to secure the necessary control of distribution to emphasize the architectural features.

The monument shown in Fig. 31 is 284 ft. high and stands in an open circle. To light the narrow shaft most efficiently requires the use of parabolic reflectors giving a concentrated distribution of light. The projectors are placed in four groups on the surrounding buildings at a distance of 230 ft., and a total of 25 kw. is employed.

The Woolworth Tower, Fig. 32, receives its illumination from 550 projectors of the 250-watt size. The average power consumption increases from 0.75 watt per sq. ft. at the lower section to four times this value at the top. The use of small units with considerable latitude of adjustment was here required because of the necessity for mounting the equipment on the Tower itself and the desirability of preserving the vertical lines which form the main architectural feature. The glazed terra cotta surface of this Tower<sup>8</sup> complicated the design of the system.

#### LIGHTHOUSES

Lighthouses differ from the projector applications discussed above in that they exist for orientation purposes rather than for the illumination of other objects. Questions of visibility here pertain to a point source, that is, one subtending an angle of less than 30 seconds, the limit for the resolving power of the eye.

Metallic reflectors were at one time employed in this service but are now found in only a few installations on lightships. Lens systems form the standard equipment, and their application in this field is notable for the large effective angles and hence the high efficiencies obtained. The careful correction of these lenses has led to a degree of control surprising in view of the extended sources of relatively low intrinsic brilliancy employed. Reliability, simplicity and low cost of operation, rather than extreme intensities, are the primary requisites in the majority of lighthouses. From the optical standpoint, electric arc or concentrated incandescent lamps are most nearly ideal, but since central electric service is seldom available, their application requires an installation of high initial and operating cost with skilled attendance. For these reasons, oil lamps, of both the wick and incandescent mantle type, are still generally employed. The former is the most reliable of all sources; the latter excels it in brightness and

<sup>8</sup> Electrical World, Vol. 68, page 412.



Fig. 30.—Representative flood-lighting installation.

(Facing pag. 242.)



Fig. 31.—Representative flood-lighting installation.

has the lowest operating cost of any lamp used in the service. Electric lamps are installed in some of the more important lighthouses where high intensity is necessary. They are also found on all the larger light vessels.

The lens systems are divided into orders according to their focal lengths, ranging from 150 mm. for the 6th order to 920 mm. for the 1st and 1330 mm. for the hyper-radial. For fixed beams, giving a band of light continuous in a horizontal plane, the lenses are cylindrical in form about a vertical axis, Fig. 33. The light issues as a belt of narrow vertical divergence; this angle and the intensity of the beam vary directly with the focal length for a given light source. The central part of a typical lens covers an angle at the source of nearly  $60^\circ$  and contributes about 60 per cent. of the light. This portion of the lens is dioptric, redirecting the light by refraction only. The upper and lower parts of the lens system are catadioptric, acting by both refraction and total reflection. The lower prisms cover about  $20^\circ$  and furnish 10 per cent. of the beam; the upper, nearly  $50^\circ$  and 30 per cent. of the light. Frequently a dioptric belt of about  $80^\circ$  effective angle is employed alone.

If lenses developed about a horizontal axis are used, both vertical and horizontal concentration is secured and a very intense narrow cone of light results, varying for a given source roughly as the square of the focal length of the lens. Such a hemispherical lens, Fig. 34, with a spherical mirror on the opposite side of the source gives a powerful beam in one fixed direction, as for range lighting along a channel. Two such hemispheres, known as the bi-valve lens, give high intensity beams at  $180^\circ$  and are utilized rotating about the source to produce the highest powered flashing effects. Another lens giving four flashes per revolution is shown in Fig. 35. By varying the design, any desired sequence of flashing with controlled period of flash and interval may be secured.

Variations from a fixed beam are introduced in part to differentiate lighthouses from each other and from shore stations. Where low intensity suffices, this is often accomplished by an occulting device which covers the source at characteristic intervals, or by rotating the lens after screening sections of it. If spherical mirrors are used as screens, the beam intensity is thereby also increased. The other important reason for the use of the flashing lens is the enormous increase in beam intensity realized; this is practically inversely proportional to the ratio of period of flash to interval between flashes.

The lenses shown in the illustration represent a recent development in that they are ground by machinery; hence all sections are interchangeable among different units of the same type. This is not the case with the hand-made imported lenses previously used; yet the new lenses, designed by Hower, are exceedingly accurate, with a divergence, it is reported, of less than one degree in some sizes, and with little scattered light.

Patterson and Dudding<sup>9</sup> found that the visibility of a point source is proportional to the candle-power and inversely to the square of the distance; that visibility is independent of brightness for sources subtending an arc of less than two minutes. Their investigation showed values for the range of lights of different colors only slightly less than the following reported by the German lighthouse Board of Hamburg as the results of their tests in 1894:

$R = 1.53\sqrt{I}$  For white light in clear weather, where  $R$  represents the range in miles and  $I$  the candle-power.

$R = 1.09\sqrt{I}$  For white light in rainy weather.

$R = 1.63\sqrt[3]{I}$  For green light in clear weather.

It will be seen that for ordinary atmospheric conditions relatively low intensities would suffice to be visible at the geographic limit. Many of the larger incandescent mantle oil lanterns give intensities of the order of several hundred thousand candle-power. Electric units give beams that are measured in millions; the largest is the Navesink equipment at the entrance to New York Harbor reported variously as from 25,000,000 to 60,000,000 candle-power. In many installations the duration of the flash is 0.1 second or even less. This is probably shorter than the time required at low illuminations to produce the same sensation as a steady beam of the same intensity. The results produced by different durations of flash and intervening periods are only partially known; nevertheless the work of Blondel and Rey leads them to conclude that for maximum utilization of a source at range limits short flashes are required.

There is a marked tendency toward using numbers of buoys instead of erecting a few lighthouses of high intensity. With Pintsch gas or acetylene these buoys frequently operate for periods as high as nine months or a year without attention. They can be operated with interrupted beams by means of mechanism actuated by the gas pressure, which turns the main burner off and on. With the large buoys it is also found economical to utilize valves which are kept closed during the day by the daylight radiation.

<sup>9</sup> Proc. Phys. Soc. London, 24, page 379, 1913.



Fig. 32.—Representative flood-lighting installation.

*(Facing page 244.)*

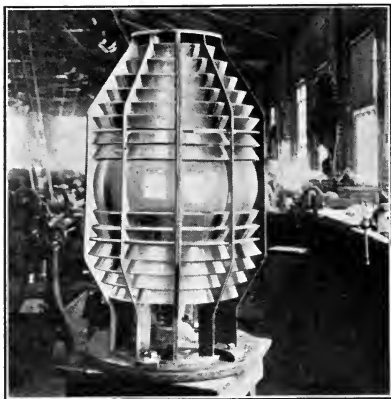

Fig. 33.—Fourth order six-panel fixed lens.

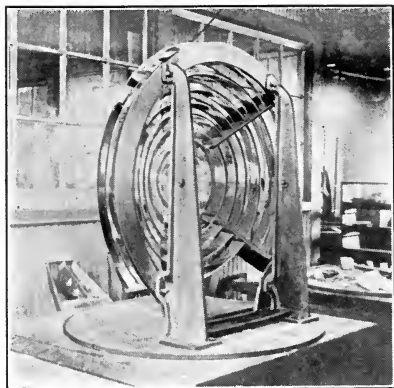

Fig. 34.—Fourth order range lens.

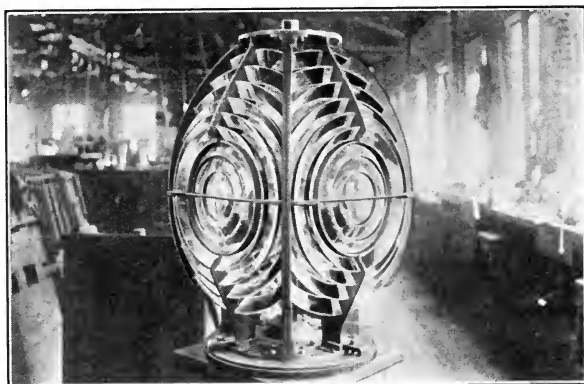

Fig. 35.—Fourth order four-panel flashing lens.

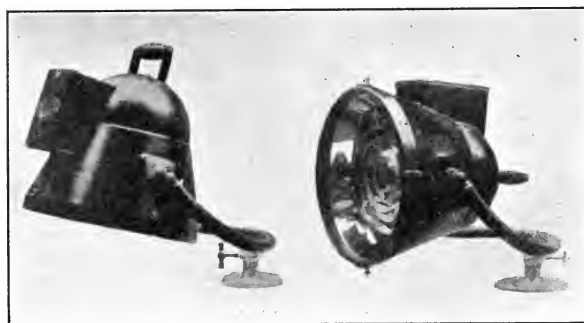

Fig. 36.—Signalling projector for aircraft

## LIGHT SIGNALS

Other applications of light signals are principally in the railway and military fields. Table V, taken from a paper by Gage,<sup>10</sup> shows the usual sizes and types of semaphore lenses with the axial candle-power values and beam spread for both the long-time and one-day kerosene burners, which flames give about one and two candle-power, respectively. The optical lens is of the usual Fresnel type with the edge of the prismatic rings toward the flame; the inverted has these pointing outward and requires a cover glass. The inverted lens has the advantage that none of the light is deflected by the risers of the prisms. The values in the table are for clear lenses. In most signals colored glasses<sup>11</sup> are employed. With the same sources, the

TABLE V.—DATA FOR OPTICAL LENSES

Diam., inches, A	Focus, inches, B	With long-time Burner			With one-day burner		
		Candle- power, C	Spread, ft. per 100		Candle- power, F	Spread, ft. per 100	
			Of 50 per cent. intensity, D	Extreme, E		Of 50 per cent. intensity, G	Extreme H
4	2¾	37.5	14.0	16.6	30.6	24.3	26.7
4	3½	40.5	12.2	14.4	32.8	21.0	23.3
4½	2¾	39.6	15.2	17.4	32.3	25.5	28.1
4½	3½	42.0	12.5	14.7	33.5	21.5	23.7
4½	3	44.5	12.9	15.3	36.3	22.3	24.7
4½	3½	48.0	11.9	14.1	38.5	20.6	22.7
5	3½	57.0	11.7	13.8	46.5	20.2	22.3
5½	3½	69.0	11.75	14.0	56.2	20.4	22.6
6	3¾	82.0	10.6	12.6	67.1	18.4	20.3
6½	3¾	90.5	10.5	12.4	74.2	18.1	20.0
8½	4	130.0	8.4	11.7	106.5	14.6	20.2
8½	5	142.0	7.4	8.7	116.0	12.7	14.0
DATA FOR INVERTED LENSES							
4	3½	35.4	14.5	17.5	29.0	24.0	31.0
4½	2¾	42.0	17.0	21.1	34.2	28.0	38.3
4½	3	51.8	16.1	19.8	42.3	26.4	35.7
5	3½	62.5	14.2	17.75	51.0	23.4	32.1
5½	2¾	59.0	17.0	19.3	48.0	28.0	53.0
5½	3½	66.8	13.8	16.75	55.3	22.7	30.3
6½	3¾	89.8	12.7	16.5	73.2	20.8	29.6
7½	3	94.5	13.5	23.7	77.1	22.3	42.8
8½	3½	120.0	11.8	19.8	97.8	19.5	35.7

<sup>10</sup> H. P. Gage, "Types of Signal Lenses," TRANS. I. E. S., Vol. 9, page 486.

<sup>11</sup> For a résumé of the subject of color and vision, see "Color and Its Applications" by M. Luckiesh.



effective range in miles for commercial colored lenses is reported by the Railway Signal Association (1908) as:

Red.....	3	to 3.5
Yellow.....	1	to 1.5
Green.....	2.5	to 3.0

The range for a clear lens is estimated at from 8 to 12 miles. The visibility is decreased when the field surrounding the lens is slightly illuminated, as in a slight haze or when other sources are near by.

Small electric lamps are rapidly coming into use in semaphore signals and, with the stronger intensities produced by these more concentrated sources, they are found to be more satisfactory by day than are the arms. In one type of equipment use is made of rows of lenses in the three arm positions. On the C. M. & St. P. R. R., three signals, red, green and white, are aligned vertically. Behind each lens are two lamps, one operating at low efficiency, to prevent failure of the signal. The normal daylight range is 3000 feet, and under the worst conditions when opposed to direct sunlight the range is not less than 2000 feet. It is reported that they are seen more easily than semaphore arms under all circumstances and that they show two or three times as far as the latter in a snowstorm.

Military searchlighting projectors have been used to transmit signals at night more than 50 miles by training the beam on a cloud. They are also used in the navy directly for day signaling over considerable distances, and have the advantage that the narrow beam precludes observation by other vessels even though only a few degrees removed. The type of shutter equipment used is illustrated in Fig. 23. Several small incandescent lamps mounted in the ring focus of a cylindrical Fresnel lens are used with a Morse key for night signaling in the navy at moderate distances, superseding the Ardois and other devices. In the European war, extensive use is made among the land forces of 1.2-c.p. metal-filament lamps equipped with parabolic reflectors.<sup>12</sup> Morse signals are reported to have been read at 11 miles at the rate of 17 words per minute with this apparatus. Fig. 36 illustrates a 150-watt signalling projector employed on British aircraft. The properties of the spherical and parabolic mirrors as well as the dioptric lens are utilized.

#### PROJECTION OF TRANSPARENCIES

One of the most familiar applications of lens systems in lighting equipment is for the projection of lantern slides and motion picture

<sup>12</sup> Illuminating Engineer, London, Vol. 8, page 62.

films. The scope of this lecture permits reference only to the fundamental optical systems and the light sources for the most common classes of equipment. Numerous treatises of a more detailed nature are available; some of the more recent ones are mentioned in the appended bibliography.

The elements of the optical system for lantern-slide projection are shown in Fig. 37*A*. The condenser intercepting the flux from the lamp becomes a secondary source having a brightness differing from the intrinsic brilliancy of the light source by only the percentage of losses in the glass, and directs a converging beam through the slide into the objective lens. The focal length of the latter is determined by the distance to the screen and the size of the picture desired

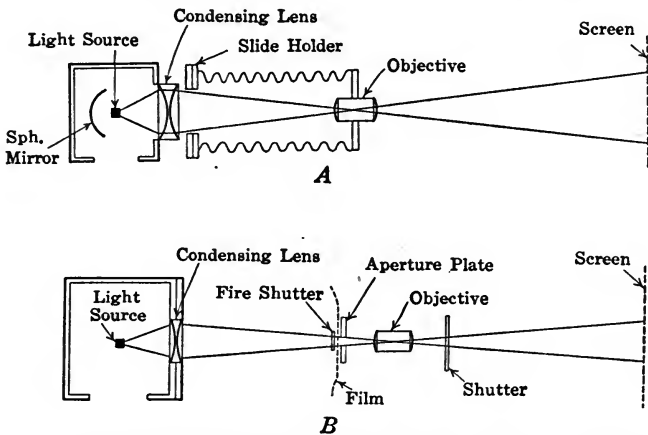

Fig. 37.—*A*, Simple optical system for the projection of lantern slides. *B*, Simple optical system for the projection of motion pictures.

Focusing for the different distances is accomplished by adjusting the position of the objective with reference to the slide. If the objective were limited to a very small aperture, the source of light would have to be highly concentrated in order that the rays might be accurately controlled and concentrated at this point. In practice, these may be made of considerable size; hence it is possible to secure the required illumination from a somewhat extended source. Cost considerations determine the best combination of source brightness and objective diameter. To secure uniform results over the entire picture, it is necessary that from any point in it a view through the objective and slide holder disclose condenser surface covering the entire area. In order to keep the condenser diameter within reason-

able limits, it is important to place the slide holder close to it. Mounting the light source near the condenser results in the utilization of the flux in a relatively large solid angle, and, therefore, makes for efficiency. The usual opening in the slide holder is  $3 \times 3\frac{3}{4}$  in. To illuminate all parts and avoid spherical and chromatic aberration requires a beam of a diameter even greater than the diagonal of the opening; thus a considerable percentage of the light is lost.

In motion picture work, Fig. 37 *B*, the intensity requirements are far more severe and the brightness of the light source is correspondingly important. The aperture of the plate through which the film is fed has an area of  $0.680 \times 0.906$  in. It is, therefore, placed well forward of the condenser in the narrower part of the beam. Additional losses are encountered through the necessity for a shutter, usually a sectored disc, to cut off the light during the period of film shifting, which occurs, with the usual pictures, 16 times every second. Since this frequency would be apparent as a distinct flicker, a two-wing or three-wing shutter is provided so that the light may be shut off 32 or 48 times per second.

Kerosene and acetylene flames, incandescent mantles and Nernst glowers and oxy-hydrogen lime light sources, have all been employed in the projection of lantern slides. To-day electric arc and incandescent lamps are used almost exclusively.

The positive crater of the direct-current arc is particularly desirable as a source of light because of its high intrinsic brilliancy. It is not practicable to utilize the maximum brightness since the electrodes must be so arranged that the positive tip is at an angle with the condenser or that the negative shades a part of it. In order to keep the arc steady, it is desirable to have a small negative electrode, and this is secured with the necessary current-carrying capacity by coating the carbon with metal. For lantern slide projection,<sup>13</sup> currents of from 4 to 25 amperes are found ample, with electrodes ranging from 6 to 13 mm. in diameter. For the ordinary motion picture films, currents of from 40 to 110 amperes are employed with positive electrodes ranging from 13 to 25 mm. in diameter and negative electrodes of from 8 to 22 mm., depending upon the current and the composition.

Alternating-current lamps of low amperage are operated with a long arc. Since the arc is continuously reversing, there is no sharply defined crater of high brilliancy on either electrode. Such lamps are distinctly inferior in efficiency to the direct-current arcs, although

<sup>13</sup> R. B. Chillias, Jr., "Projection Engineering;" Trans. I. E. S., Vol. 11, page 1097.

ample for most lantern slide work. For motion picture projection, the alternating-current electrodes are operated close together to secure better craters. The electrodes are inclined to each other so as to expose as much as possible of one of the tips to the condenser. However, the brightness of the source is still lower than with direct-current, and considerable shading results due to the interference of the other electrode. Shutters employed with alternating-current equipment are of the two-wing type; the three-wing shutter with a frequency of 48 per second gives rise to stroboscopic effects with 60-cycle current.

Incandescent lamps of special concentrated-filament construction are used for the projection of lantern slides under all conditions, and take care of the requirements amply. Recently the gas-filled tungsten-filament lamps have also been successfully applied

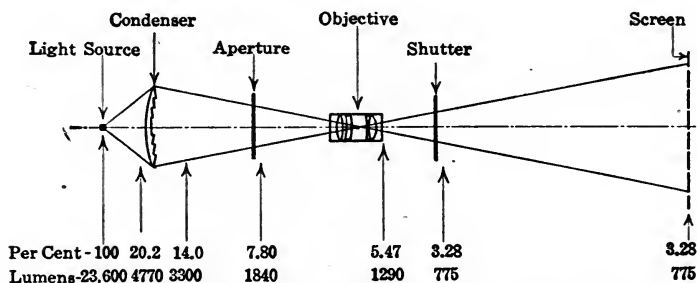

Fig. 38.—Typical efficiency chart for motion picture projection with mazda lamp; machine operating without film.

to motion picture projection. It will be seen from Table I that the brilliancy of such sources is still below that of the carbon arc; nevertheless, their application is feasible because of other advantages gained. Among these is a somewhat more efficient utilization of the flux due to the fact that the source can be placed closer to the condensing lens. When used with objectives of the larger apertures the incandescent filament is found to be sufficiently concentrated, and the intensification of flicker and irregularities produced by such lenses with arc sources is obviated. The steadiness of the light and the elimination of operating difficulties are quite as important as the reduction in operating cost realized. In Fig. 38 are shown the utilization and losses of the flux in such apparatus. Although the losses in the system may appear high, it should be noted that the results for each part of the apparatus are superior to those secured with most equipment in use to-day. The illumina-

tion intensity on a picture area of 150 square feet is seen to be in excess of 5 foot-candles.

The question of the most desirable intensity for motion picture projection is one on which a difference of opinion still exists. The Committee on Glare of the Illuminating Engineering Society<sup>14</sup> has recommended a brightness for the picture corresponding to a screen illumination of 2.5 foot-candles with no film in the machine, with a factor of 5 either way. A brightness which is too high causes not only fatigue to the eye, but also makes the flicker, wandering of the arc, etc., more pronounced. It appears that the present high-current arc installations are operating in the upper range of desirable intensities.

## BIBLIOGRAPHY

### GENERAL PRINCIPLES OF LIGHT PROJECTION

BENFORD, F. A., JR.—“The Parabolic Mirror;” *Trans. I. E. S.*, Vol. 10, p. 905.

GAGE, S. H. and H. P.—“Optic Projection;” Comstock.

NATIONAL LAMP WORKS OF G. E. CO.—“Mazda Lamps for Projection Purposes;” *Eng. Dept. Bulletin No. 23*.

ORANGE, J. A.—“Photometric Methods in Connection with Magic Lantern and Moving Picture Outfits, and a Simple Method of Studying the Intrinsic Brilliancy of Projection Sources;” *G. E. Review*, Vol. 19, p. 404.

PORTER, L. C.—“Photometric Measurements of Projectors;” *Lighting Journal*, Vol. 4, p. 7.

“New Developments in the Projection of Light;” *Trans. I. E. S.*, Vol. 10, p. 38.

### AUTOMOBILE HEADLIGHTING

CLARK, EMERSON L.—“Automobile Lighting from the Lighting Viewpoint;” *Bull. Soc. Auto. Eng.*, April, 1916, p. 45.

Discussion.—“Headlight Glare;” *Bull. Soc. Auto. Eng.*, Feb., 1916, p. 296.

Symposium.—“Glare-Preventing Devices for Headlights;” *Trans. Soc. Auto. Eng.*, Vol. 9, Part II, p. 284.

### RAILWAY HEADLIGHTING

American Ry. Master Mechanics Ass'n.—“Report of Headlight Committee;” 1914.

Ass'n. of Ry. Elec. Engineers.—“Report of Committee on Locomotive Headlights;” *Ry. Elec. Eng.*, Vol. 5, p. 199.

BABCOCK, A. H.—“Southern Pacific Six-Volt Electric Headlight Equipment;” *Ry. Elec. Eng.*, Vol. 7, p. 233.

<sup>14</sup> Committee on Glare, “Diffusing Media; Projection and Focusing Screens,” *Trans. I. E. S.*, Vol. 11, page 92.

BAILEY, P. S.—“Incandescent Headlights for Street Railway and Locomotive Service;” *G. E. Review*, Vol. 19, p. 638.

HARDING, C. F., AND TOPPING, A. N.—“Headlight Tests;” *Trans. A. I. E. E.* Vol. 29, p. 1053.

MINICK, J. L.—“The Locomotive Headlight;” *Trans. I. E. S.*, Vol. 9, p. 909.

PORTER, L. C.—“Meeting the Federal Headlight Requirements;” *Ry. Elec. Eng.*, Vol. 7, p. 468.

*Ry. Elec. Engineer*, Vol. 3.—“Electric Headlights—Wisconsin Railroad Commission Tests.”

SCRUGHAN, J. G.—“Electric Headlight Tests;” *Ry. Elec. Eng.*, Vol. 5, p. 349.

Symposium (SUGG, CHAS. R., DENNINGTON, A. R., PORTER, L. C.).—“Theory, Design and Operation of Head-Lamps;” *Elec. World*, Vol. 62, p. 741.

#### SEARCHLIGHTING

BLONDEL, A.—“A Method for Determining the Range of Searchlights;” *Illuminating Eng. (London)*, Vol. 8, pp. 85, 153.

CHILLAS, R. B., JR.—“Searchlight Carbons;” *Journal of U. S. Artillery*, March-April, 1916, p. 191.

*Electrical World*.—Vol. 64, p. 181; “Search Lamp with Vapor-cooled Electrodes” (Beck). Vol. 68, p. 611; “High-Intensity Searchlight for Governmental Purposes” (Sperry).

McDOWELL, LIEUT, C. S.—“Searchlights;” *Proc. A. I. E. E.*, Vol. 34, p. 195. “Illumination in the Navy;” *Trans. I. E. S.*, Vol. 11, p. 573.

NERZ, F.—“Searchlights; Their Theory, Construction and Applications;” *Van Nostrand*.

Symposium (LEDGER, P. G., AYRTON, MRS. HERTHA, TROTTER, A. P., etc.)—“Searchlights; Their Scientific Development and Practical Applications;” *Illuminating Eng. (London)*, Vol. 8, pp. 53-84.

WEDDING, W.—“A New Searchlight” (Beck); *Electrotechnische Zeitschrift*, 1914, p. 901.

#### FLOOD LIGHTING

BAYLEY, G. L.—“Illumination of Panama-Pacific Exposition;” *Elec. World*, Vol. 65, p. 391.

*Elec. Review and Western Electrician*, Vol. 67, p. 1104; “Indianapolis Bank Adopts Flood Lighting.” Vol. 67, p. 724, “Flood Lighting of Building Fronts from Ornamental Cluster Posts.”

*Electrical World*, Vol. 67, p. 1173; “Flood Lighting a Flag;” Vol. 67, p. 1462; “Adding Hours to Summer Days for Outdoor Recreations.” Vol. 68, p. 453; “Niagara Falls Flood-Lighted.”

HARRISON, WARD and EDWARDS, EVAN J.—“Recent Improvements in Incandescent Lamp Manufacture;” *Trans. I. E. S.*, Vol. 8, p. 533.

*Lighting Journal*, Volume 4, p. 18; “Projectors for Flood Lighting.”

MACGREGOR, R. A.—“Lighting the Soldiers’ and Sailors’ Monument;” *Ltg. Journal*, Vol. 4, p. 175.

MAGDSICK, H. H.—“Flood Lighting the World’s Tallest Building;” *Elec. World*, Vol. 68, p. 412.

- PORTER, L. C.—“Pageant Lighting;” *Ltg. Journal*, Vol. 3, p. 169.
- RYAN, W. D'A.—“Spectacular Illumination;” *G. E. Review*, Vol. 17, p. 329.
- “Illumination of the Panama-Pacific International Exposition;” *G. E. Review*, Vol. 18, p. 579.
- SUMMERS, J. A.—“Flood Lighting the State House at Boston;” *Ltg. Journal*, Vol. 4, p. 2.
- UHL, A. W.—“Flood Lighting of a Great Outdoor Pageant;” *Ltg. Journal*, Vol. 4, p. 172.

## LIGHTHOUSES

- Encyclopædia Britannica*, 11th Edition.
- HASKELL, RAYMOND.—“Lighthouse Illumination;” *Trans. I. E. S.*, Vol. 10, p. 209.

- MACBETH, GEO. A.—“Lighthouse Lenses;” *Proc. Eng. Soc. Western Penn.*, Vol. 30, p. 231.

## LIGHT SIGNALS

- CHURCHILL, WM.—“Red as a Danger Indication;” *Trans. I. E. S.*, Vol. 9, p. 371.
- GAGE, H. P.—“Types of Signal Lenses;” *Trans. I. E. S.*, Vol. 9, p. 486.
- LUCKIESH, M.—“Color and Its Applications,” Van Nostrand.
- MCDOWELL, LIEUT. C. S.—“Illumination in the Navy;” *Trans. I. E. S.*, Vol. 11, p. 573.
- SAUNDERS, J. E.—“Recent Developments in Light Signals for Control of High-Speed Traffic;” *Elec. Journal*, Vol. 13, p. 443.
- STEVENS, THOS. S.—“Illumination of Signals;” *Trans. I. E. S.*, Vol. 9, p. 387.

## PROJECTION OF TRANSPARENCIES

- CHILLAS, R. B., JR.—“Projection Engineering;” *Trans. I. E. S.*, Vol. 11, p. 1097.
- GAGE, S. H. and H. P.—“Optic Projection.”
- ORANGE, J. A.—“Optic Projection as a Problem in Illumination;” *Trans. I. E. S.*, Vol. 11, p. 768.
- TAYLOR, J. B.—“The Projection Lantern;” *Trans. I. E. S.*, Vol. 11, p. 414.

## THE ARCHITECTURAL AND DECORATIVE ASPECTS OF LIGHTING

BY GUY LOWELL

There is surely no scientific profession, there is no branch of the engineering fraternity for which a thorough artistic training is more desirable than the profession of illuminating engineering. We can see, however, by looking over the list of lectures in the usual engineering courses that the technical knowledge which one should have is so great—there are so many scientific subjects to be discussed—that there can be but little time left in the curriculum for the study of the fine arts. Yet after all the aims of the illuminating engineer and of the artist are similar—it is to reach the mind through the eyes. The point of view of the engineer is, however, largely objective. He often seems to think that his mission is ended when he has made it possible to convey to the mind the facts—as they are. The artist idealizes and wishes to state the facts as they might or should be, or as we say, colloquially, he wants to show them in the best possible light. These two methods of seeing—the subjective method and the objective method, are often not very different, and I want to spend my time this morning considering the common aims of the illuminating engineer and the artist, and show how close together the paths of the two really lie.

We have been taught that were it not for the reflected light that comes from all the different objects on this earth of ours, our world would appear to be in darkness, because we could not see the objects around us. There might be sources of light, like the fire, the incandescent filament, or the electric arc which would be visible in themselves, but the light that comes from the heavens or from some man-made source must be reflected from an object in greater or less intensity for us to be able to *see* it. Furthermore, we all know that the effect that an object makes on the retina and thereby on the mind is dependent on the way the light is reflected from an object, and partly therefore on the way the light falls on that object.

Since it is this pattern made by rays of varying intensity and of varying color on the retina, calling up various reminiscences to our mind, that enables us to see—to understand what lies before us, it



follows that the type of lighting that sets in motion the most powerful train of associative ideas is the one that may have the greatest emotional effect; but the intensity of the emotional effect is not measured by the intensity of the light even though the intensity of that light may affect the clearness with which we judge of the physical aspect of the object on which it falls. We are not always necessarily interested, however, in the physical aspect—in the intricate details of the object at which we are looking. We are often more interested in the memories it calls up. Let me illustrate what I mean by an example.

When I realized some weeks ago that I was going to talk to the members of this society on the æsthetic principles instead of the scientific principles involved in some of the every-day problems of lighting, it occurred to me to get a variety of opinions on the mental reaction produced by such a simple source of light as one bright star in the midnight sky. So I asked three people among my neighbors—one a distinguished astronomer, the next a young girl just back from college, and the third an immigrant woman whose husband worked as gardener on the place—what their thoughts would be were they to wake up in the middle of a wintry night, and as they came back to consciousness were to see through the window a bright star. The astronomer said he would begin to wonder which star it was among all the myriads in the heavens; the young girl with a mind full of classical poetry said she would think of the mythological stories connected with the stars; the working woman said, "Sure if it was a single star on a wintry night I would think of the Star of Bethlehem."

But when I said to each one of my three friends, "Supposing you were told that it was not a star after all but a distant electric light, what would you do?" They all three made a similar answer, "We'd turn over and go to sleep."

Now the interest in these answers lies here. No one of the three was interested in the one little bright spot in the sky as a source of light; so long as it was a star, it called up a whole series of associative thoughts.

Whether it calls up with its suggestion of infinite distances and infinite time a whole theory of cosmic philosophy; or whether it suggests to the pagan mind the mythological intrigues of a Jupiter, a Mars and a Venus; or whether the star recalls one of the most touching stories of our Christian faith—the story of the Star of Bethlehem seen by the watching shepherds from the hillside nearly

two thousand years ago, certain it is that most of us when we see the brilliant star set in its wonderful background of midnight blue, project into our thoughts the reminiscence of some earlier associated idea, and thereby enjoy intellectual pleasures that we could not get from the mere contrast alone of a brilliant light against a dark background. That one little spark of light in the sky is able to suggest a whole train of speculative thought, and serves as a strong stimulus to the imagination; in other words, fulfills the functions of a *work of art*, for in stimulating the imagination it has called up thoughts of beauty.

What I want to consider more particularly to-day is the artistic function of lighting and show how the lighting scheme of the scene at which we are looking may quite independently of its efficiency, technical excellence or physiological advantages, control the emotional reaction which it produces—influences the æsthetic result produced. Now instead of a single star, the scene at which we are perhaps looking may be the harmonious grouping of the many different objects in a natural landscape or inside a room, all reflecting different kinds of light in different ways and combining to make up the picture that is conveyed to the mind by the eye. I have already said that the strength of the intellectual reaction made by the picture we see is in no sense dependent on the intensity of the lighting, nor necessarily on the clearness of vision with which we see the objects in our scene.

Let me show you again that the artistic effect is quite as much due to the train of associative ideas it calls up as to the clearness with which we see that scene. For this purpose I am going to use as an illustration an outdoor scene, since we can select some beautiful view and nature will kindly shift the light for us, so that in our outdoor laboratory we may judge of the changing thoughts produced by the same or similar scenes but under different conditions of lighting. In order to show the difference between a scene clearly defined because of its uniform lighting, and a similar scene where only the important elements are brought out by the artist, I would ask you to compare a photograph of some familiar object with a painting by an artist of that same object.

Photography is of use because it provides an illustration of the way we really see things in that it gives a record full of detail of what we see. The image permanently produced on the photographic plates after chemical development is monochromatic it is true and cannot by black and white present all the different colors nor are the light

values in the photograph always relatively right, but the direct photograph being what one might call a mechanical record of the scene before us provides us with an interesting way of comparing actuality with the way an artist would treat a similar scene, for the artist first looks, then apprehends, and then selects from all that he sees only that which he desires to record.

The painter with his easel set up about to paint a landscape or a portrait waits till the lighting on his subject is just right, of the proper concentration or diffusion, from the right direction, of the right color, and is, therefore, dependent on the vagaries of nature. And to him the proper lighting of his subject is of tremendous artistic importance. Artificial light in the hands of the illuminating engineer can be controlled and arranged as the artist wishes, and the architect in the planning of his lighting scheme considers the same rules of composition, studies the same effects of contrasts, produces by the position of his sources of light the same harmonies of line that the painter patiently waits—often day after day—for nature to produce.

Right here we must emphasize once more the fact that uniform visibility and great distinctness of vision are not necessarily desirable; it is wrong to assume that because, for instance, much time, thought and money have been spent on some decorative detail, or even on some art object among a collector's treasures, that it must be clearly brought out in the picture as a whole—that what is costly and of value should, to use a naval expression, have high visibility.

The artist does not want you to see everything with equal distinctness. In his composition as in a symphonic poem some of the most beautiful passages, though full of suggestion, are low in tone, thus bring out in greater contrast the general theme—throwing a high light on some other beautiful part. The musical composer only puts into his composition what he believes to be of importance to the creating of a proper impression of the whole; the artist or the worker in black or white *leaves out* what he does not want. The artist who arranges the light sources, who provides the illumination of a building must do the same, and the elimination, in the picture that presents itself to the eye, of the undesired elements by one method or another, should be an important part of his artistic result.

The illumination of work shops, clerical offices, manufacturing plants, mercantile buildings—as well as schools and buildings more directly under governmental control has been carefully studied, and we have been told at this convention here of the increased efficiency, the better health and the greater freedom from accidents that have

been brought about by a proper and efficient system of lighting and by the proper treatment of the wall surfaces and ceilings, so that they will not absorb an undue amount of light. That is a practical problem that you gentlemen are well qualified to solve; but the architect is at times, when he is not building loft buildings, offices, hospitals or industrial plants, but is designing buildings that are to serve for rest and for recreation rather than for work and efficiency, called upon to forget cost of operation and to neglect efficiency in order to produce a greater emotional effect. I am making a plea for the architect. You as engineers have not done your complete duty when you have thrown enough light by some economical system that does not require the paying of too large tribute to the electric light company, to enable one to see clearly all part of some new building.

You may feel that I am talking too much about beauty, and too little about lumens and amperes, but after all I am only telling you how the trained artist with his surety of taste resulting from his long study of composition must always study to make lighting right, æsthetically, for that enables him to show the form and the color of what he represents in the most artistically effective way

That from an architect's, as well as the artist's point of view is the artistic function of artificial lighting.

The architect, however, is constantly trying to apply his artistic ideals to the practical solution of his problem. He recognizes at times that the utilitarian must prevail, but he also believes that there are times when the æsthetic appearance is of paramount importance and his resulting lighting scheme may be neither economical nor physiologically correct.

We are often told that whatever is scientifically right must be good artistically, and that whatever in our universe is functionally correct and calculated to its needs with nicety is beautiful for that reason. I do not entirely believe that myself, but I am going to concede to a gathering of the scientific-minded like this that the scientific solution is undoubtedly the best for most *problems*; but qualify it by saying that the scientific mind often finds it hard to grasp what the artistic *problem* really is, for science is dealing with facts, is interpreting them and converting them to use, but is not interested in the emotional effect, for that is dependent on the different reaction on different individuals.

For the understanding of many of these problems where the artistic and the scientific seem to come in conflict real powers of imagination seem necessary. What is imagination? Imagination might be

defined as the power to realize that there are variations from the rule and that such variations require a special treatment. If you agree with that definition of imagination consider the artistic treatment of the lighting problem as a possible variation from the rule and allow your imagination full play.

So the lighting scheme laid out by an architect in connection with a building may be for one or two purposes:

(a) Primarily for use and not for decoration.

(b) To produce a decorative effect without special care being taken to have it economical and efficient from the engineering standpoint.

In a practical system of architectural lighting the usual object is to reproduce in so far as economical utilitarian consideration will allow a properly diffused light resembling daylight if possible, and in sufficient quantity to enable one to do one's work or see about the lighted rooms or spaces with absolute ease. The best way to obtain such scientifically worked out lighting so that it shall be efficient and economical is really a practical question and not an æsthetic one.

In what I consider an artistic scheme the sources of light screened or unscreened are grouped in such a way as to produce not diffusion but contrasts. The spots of strong reflected light and the spots of deep shadow are composed much as artists would compose light and dark spots in a drawing or painting. I have an admirable illustration in mind of two art museums with these two absolutely different types of artificial lighting. They are the Art Museum in Boston and the private collection of Mrs. Gardner near it. At the Museum we tried to arrange the light so that it will as nearly as possible reproduce in direction and color the daylight—those are the conditions that exist during the greater part of the time that the Museum is open—and there every object can be clearly seen and studied. Mrs. Gardner lights her rooms with a few candles placed around so that some one particularly interesting object can be seen, standing out as it were from the surrounding shadow. No indirect lighting system in her house could begin to have the same charm.

Even in an art museum the chosen method of lighting might depend on whether it is for use or for artistic effect.

In my garage, in my kitchen, and in my work room, I try to diffuse the electric light as much as possible by reflecting surfaces. In my own dining room and parlor, however, though I have electric light brackets on the walls, they are never turned on, and the room is either lit entirely by candles, or by candles and portable lamps.

Let me illustrate these two different ways of looking at the same

thing—that is, the objective and the subjective. Consider, first of all, a photograph of a bridge; every detail is clearly brought out in the picture, the arches of the cement bridge, the trolley poles, the roadway, the ugly buildings, all jumbled together. No artist composed the picture—it is just a record of homely facts. Now let us see a bridge through the eye of an artist. Perhaps it is a little unfair to contrast with the photograph of a modern cement bridge, say, one of Whistler's lithographs, but this shows in a simple drawing the beauty the artist saw in what is really a very ugly bridge. He tried to express only as much of the bridge as seemed to him in his mood at the time as necessary to call up a certain impression. In other words he threw the light on only the essentials and left the unessentials undefined. To some this drawing calls up a long train of associative ideas, to others it represents little more than a beautiful pattern in black and white. I would have you consider the *Presentation in the Temple*, by Rembrandt. Here we have the strong lighting of the important figures, the background subdued, and only half felt to be there, like the subdued accompaniment to the principal melody in music. We might almost think that Rembrandt had invented the modern theatrical spot light in his desire to accent strongly the personages in his picture, and this characteristic of strongly marked high light is produced in all his paintings, because he knew that skilfully disposed lights, despite the strong contrasts, produce an agreeable pattern of lights and shadows. There is a simple way to study composition, by taking the paintings of the acknowledged masters, and when we are sure that we like a certain work try to analyze its composition, judge the composing of light and try to express in ideas, in words, wherein its excellence lies.

Nature, too, has a lot to teach us. We suddenly come on an opening in the woods, and the scene before us seems to make a satisfying and inspiring picture. To what is the charm due? Is it the color of the young green leaves with the sun shining through them; is it the sweep of the tree trunks and the branches into a smooth and flowing pattern; is it the distant vista of lake or mountain? It may be one or all of these, but there is always the light which above all is just right. Were it to come from a different direction, the leaves would be in shadow, the dark lines of the branches would make a different pattern, the high lights would be differently placed. But to have just the right picture you must see your scene as the artist would with its chosen lighting.

Now let us consider scenes by other painters. Gainsborough, full of vigor with strongly marked lines in the composition; Turner with a satisfying and harmonious sweep of line from one side of the canvas to the other; Rembrandt with his high lights like the strong blare of the trumpet in an orchestral piece.

You see efficiency and intensity of lighting are left far behind in our minds when it comes to tracing harmonious patterns and producing wonderful blendings of color and light and shade.

Think of the advantage you have as artists if you will so consider yourselves. You hold in your hand brushes dipped in light; you have a palette set with all the colors that we find in nature. You can make your high lights shimmer at will. You can throw the confused detail into the mysterious and shadowy background. Equipped with a sound technical knowledge, the effects you can produce are only limited by your artistic training. But the road to art is long. A short lecture like this can only show that there is such a road; it cannot for a moment do more than that. For the power to understand the artistic impulse, the power to create what is artistically good, must come as the result of years of thought and study.

We have given a hasty glance without attempting to classify them at the lighting schemes of nature in outdoor landscapes. The most direct copy of those effects of lighting we find on the stage of the modern theatre.

There the aim is to produce illusions, to produce the illusion of reality, not necessarily as we have ourselves experienced it, but as we can conceive that it might exist, and there are no limits to-day to what one can do. For that reason the conventions for lighting of the stage of the last generation are disappearing. The strange effect produced by footlighting, with the resulting prominent chins and receding foreheads, is giving way to a flood of colored light producing the effect of a shadowless stage where the whole company is suffused in light. We are now looking at a pattern of color and even the advent of solid properties on the stage has failed to give us quite the real sense of solidity that comes with the feeling of modelling one gets from natural unilateral lighting. The thoughtful stage manager tells us that we have not solved his problem because he has to work with color and has to give up attempts at modelling. But since he states that the problem needs solving, you gentlemen must help him.

I have purposely made this comparison of unilateral lighting out-

doors, and diffused lighting on the stage because the stage manager with all possible kinds of lighting at hand has to resort to the subterfuge of painted shadows in order to make objects on his stage appear real, to appear solid. He paints a shadow under the cornice of a building, he shades one side of a real round column with paint, he even darkens the eye sockets and wrinkles of the actors. Though he is working in a space suffused with light he must paint in shadows to make his picture real and solid. And painting will not take the place of real high lights and real shadows as nature produces them.

It is exactly the same thing in lighting our buildings, we must make them seem real, and what is more, make them seem solid.

We thus see in our examples chosen from natural landscapes and from the work of the landscape painters that the emotional reaction of the scene before us when we are in the open looking at a natural landscape—that the mood produced in us by the artist's painting is largely affected by the way the lighting is done. We also see how the theatrical manager, with the wonderful power of creating impressions, of inducing sensations, which is given him, is again absolutely dependent on the varying effects of lighting for painting his stage lights and his shadows. But the final effect produced on the individual is dependent on the taste of the individual. And the individual's taste is the result of experience, of education, of varying reminiscences, and it therefore is impossible to dogmatize and say that such and such a way is the best way to light a given subject.

Some one asked me which I preferred for the exterior of a monumental building—a row of incandescent lamps or flood lighting. How can I say? I do know that the answer depends on what the architect is trying to emphasize and on what he is trying to hide.

Consider flood lighting for a moment. It is rarely so done as to do justice to the architecture. It was all right at the San Francisco fair. It was wonderful in fact because like on the stage spoken of a few minutes ago it served to bring out color and not form. But as used on the occasional building it is hardly so successful, for instance, the Boston State House last fall, or the new Technology buildings last spring. In the case of the last two buildings the architect had worked out all his contrasts of opening with wall space, all his contrasts of supporting column with its lintel, to be seen by daylight, and by daylight the light comes from above. How can one expect flood lighting to do anything but invert the architectural effect if it is thrown up from a lower building onto a higher one? And how can you expect the interior of a building to be artistically satisfactory



if the light that comes from the windows by day produces a composition that is entirely inverted by the change in direction of the artificial lighting at night.

How do these theories work out in our homes? There can be no one accepted set of rules for the guidance of the man who lays out the electric lighting in a private house. I personally like as few light sources as possible, and I certainly only put in wall brackets, because handsome, skilfully designed electric brackets are of value decoratively on the walls, but as I have already said I never light these in the living rooms in my own house.

I remember that when I first built a big room for the furniture which I had collected while living abroad, we all gathered one evening to discuss the position of the various pieces and to move them around till we thought all were perfectly placed. The room was lighted by electric wall brackets, some old French ones I had had wired, and by lamps on the tables—they were connected to floor receptacles. Nothing around looked right! We almost broke our backs for two hours, moving the furniture, but each change seemed only to make the composition worse. I turned the switch which extinguished all the wall brackets. The room suddenly felt "right." What I found was successful in my own case is what I now try to apply for my clients. I get along without light from the wall brackets.

So when it comes to the varying treatment of the different rooms of the house I don't for a minute concede that efficiency alone should be the keynote; what we should have above all is a beautiful effect. Yet, we should have enough light for the average person. One's old Jacobean oak staircase should be light enough so that a short-sighted person will not fall down and break his neck, but there might be some of the dim mysteriousness of the ancient staircase arranged for in its lighting.

I want to lay great emphasis here on the difference there is between rooms in public buildings and similar rooms in private buildings. Take for instance the reading rooms in a public library and the library (reading room) in a private house. It is obvious that the public reading rooms should be so lighted that a maximum number of workers should be provided for, every reader in fact should have the light fall with the correct intensity and from the correct angle. But the private library is quite different. Half the time the people sitting in it may not be reading; at any rate it surely needs to accommodate not more than one or two actual readers at a time. There should be light enough to enable one to see the people around the room

but in my opinion the rest of the room should be only so lit as to make the most artistic background. In one corner you may see a lamp on a table throwing its light onto the richly bound books in the bookcase—and there is nothing more decorative for a background than handsome bindings; in another you may see a well placed picture lamp or the worker's desk lamp. But there should be no attempt to make the room look like a picture gallery. The use of picture lighting in a private home is a matter of personal taste. So many of the large homes to-day make claims to have valuable collections of paintings stored in them that the owners feel that they should be shown off to the greatest advantage at all times; hence, that abomination of the architect the modern picture lamps, with their reflectors bracketed out from the wall or ceiling about the picture.

Again let me say that there must be a difference between the lighting of the room of a public building and a private one. Put your fine pictures, if you must show them off and not enjoy them quietly and separately, in a gallery with all the advantages of a carefully, skilfully worked out lighting scheme, shown where they can be seen to the best advantage, but don't force your guests to eat in a picture gallery because the dining room has some of the owner's choicest paintings in it, brilliantly lighted by reflectors. I have in mind one beautiful walnut panelled room where each picture on the wall at night is so brilliantly lighted that every picture with its frame seems like a window cut in the panelling looking into the landscape beyond, and there is no sense of support in the wall surface.

Let us make another comparison—the dining room in a public restaurant and the private dining room. When I go to a public restaurant I find in America that the desire is to have a brilliantly lighted room, profusely lighted by different sources. My own dining room however is a Jacobean oak room taken from an old house in England. Near the pantry door there is a hidden receptacle which is used with a lamp and a reflector when the table is being set. When all is ready for the guests the lamp is removed and the room is lighted only by candles. No system of lighting that I know makes a more becoming light for the guests, or sets off the linen, the china, and the silver to better advantage. Each source of light too is so low in intensity that its contrast with the dark background is not unpleasant. I like to see a similar method of lighting applied to the restaurant dining room because I personally, though I go to a public dining room, like to confine my attention to the people at the same table with me. I like the sense of privacy which the French like

even in a public restaurant. Sherry's in New York is arranged that way. There are, however, many people who go to a restaurant to see or to be seen throughout the room; for them some system of indirect lighting may seem more practical.

The private house, should as you pass from one room to another, provide a series of pictures, where the furniture, the light sources, the people are all so combined as to make an artistic and picturesque composition. Like the landscape painting we already considered it will have individuality in which the lighting will be the controlling factor. You can perhaps now understand my personal objection to indirect lighting. It makes it so hard to compose the picture.

You must not assume, however, that indirect lighting according to my opinion has no place in a well arranged home. For there are many cases where it is advantageous to obtain our light from a large surface with a low intensity rather than single sources of concentrated light. I have the evil habit for instance of reading in bed. My bedroom is sanitarily painted in white. I throw the light with two strong reflectors onto the wall behind me and obtain a wonderful light on my book or over the large pages of a newspaper. Scientifically correct but artistically vile. But then I don't receive visitors in my bedroom.

The transition from the private dwelling to the art museum is direct.

It has always been my contention that the ideal public art museum should have many of the characteristics of a private house. Most of the objects in it were originally made for everyday use. Pictures were to be hung on the walls of the living rooms. China, silver, furniture, fabrics, carvings were all used in rooms that were human in scale. There are a few colossal paintings, a few heroic statues to be provided for, but surely the keenest artistic pleasures come from seeing works of art in the surroundings for which they were intended. Modern tendencies in museums have been in the other direction, however. The tendency was to group all the paintings together, to put all the furniture in another group, and the *objects d'art* off by themselves. This has been, I think, largely due to the fact that the administrative staff of many museums have thought too much of the executive part of their work and too little of the artistic part.

The art museum is for the student, but it is quite as much for the occasional visitor as for those who frequent the galleries day after day. Now the constant passing through the galleries, the constant work in the exhibition rooms of the museum staff is apt to make them

consider the visual comfort of the constant worker even more than the æsthetic satisfaction to the occasional visitor who comes to get the artistic stimulus of seeing beautiful things skilfully shown in pleasant groupings.

This all creates a two-fold problem, for the objects must be clearly lighted with a considerable intensity of light and yet it is of paramount importance that the ultimate effect of the galleries as a whole be harmonious. It is at once a practical and an artistic problem and the method adopted in arranging for the lighting of such a building offers a good example of the way the artist must always attempt to solve the problem of lighting both by daylight and by artificial light.



## COLOR IN LIGHTING

BY M. LUCKIESH

### INTRODUCTION

It appears desirable from an analytical viewpoint to divide the problem of lighting into two parts, namely, that which involves light and shade or brightness distribution, and that which involves color. In dealing with the first part, the lighting expert is concerned with the distribution of light and with the second part, with the quality or spectral character of the illuminant. Sometimes these two problems are intricately interwoven but there is much advantage in general in considering the problems separately especially if it be granted that lighting should be considered from the standpoint of the appearances of objects either singly or as a group.

The subject of color in lighting is complicated by the fact that the eye is not analytic but synthetic in its operation. For instance, a color sensation in general is the result of the integral effects of radiant energy of many wave-lengths or frequencies. Often it is necessary to know the luminous or energy intensities of these various components yet sometimes merely the subjective or resultant color is of interest. Spectrum analysis yields the desired data in the former cases while such instruments as the monochromatic colorimeter furnish satisfactory data in the latter cases depending upon the problem at hand. One of these two viewpoints must be chosen by the lighting expert for a given problem.

It is not the intention to ask the lighting expert to become a color specialist and it is impossible to present a complete treatment of the subject of color in lighting in a single lecture. However, it will be the aim to present a sufficient amount of the science of color to enable the lighting expert to diagnose his problems and a sufficiently varied number of applications of color in lighting to show the trend of progress and to impress him with the extent of the field if necessary. Notwithstanding the brevity with which the theory of color will be presented it may appear to some that it is unnecessary to be acquainted with some of the aspects discussed. However, it cannot

be too strongly emphasized that an art is an applied science; that is, science is the tool.

In the practice of color science it is desirable that definite terminology be used consistently. The measurement of color is necessary for specifying installations and for recording results. Many applications of color in lighting are directly dependent, for successful results, upon a knowledge of the principles of color mixture. Obviously color and vision are closely related in the applications of color in lighting but unfortunately many of these relations cannot be discussed here. The psychology of color is of extreme importance but many of the questions raised by the lighting expert are at present unanswered. The color of surroundings is of much greater importance than has been generally recognized in practice. The surroundings influence the visual impression and also the color of the useful light. It should be recognized that the color exhibited by the lighting unit very often plays a dominating part in the impression of a lighting condition even in those cases when the color of the useful light is far different from the color of the visible portion of the unit. Wrong conclusions have been arrived at by failing to recognize such facts as the foregoing or, in other words, by not applying a searching analysis to the conditions. Artificial daylight has been demanded for many places and it is now practicable owing to the relative high efficiencies of modern illuminants. Many arts have been standardized in daylight and the eye has been evolved under daylight conditions. For these reasons, and others, artificial daylight finds many fields of application. Artificial daylight units have been available for some time and it is now possible to record some experiences gained from a great many installations. On the other hand, æsthetic taste sometimes demands that the early illuminants be simulated in color. This provides an interesting aspect although the problems are not difficult because only the subjective color is usually of interest. The means for obtaining various color effects are gradually being developed although the lighting expert must yet provide colored media for many special applications. It has been thought desirable to conclude this lecture with brief descriptions of a number of applications of the science of color in lighting and the appended bibliography will be depended upon to cover much that cannot be incorporated in a single lecture. It appears best not to attempt to incorporate much numerical data obtained from experiments in the various fields treated in this lecture because these data are available elsewhere (see Bibliography). The method of treatment, therefore,

will be general, the more important viewpoints will be discussed and an attempt will be made to present a broad discussion of an extensive subject.

### COLOR TERMINOLOGY

There is a great need for the standardization of color terminology and for the development of a practicable system of color notation. Many terms are in use for describing a few color qualities and there is great confusion owing to the fact that the same term is used by different persons to describe different factors or various terms are applied to the same factor. It appears unnecessary to recount this confused state but it is advisable to propose terminology to be standardized by this society. The proposals which follow appear to the author to be the most satisfactory and the most consistently used.

Color can be considered from two broad standpoints. Spectrum analysis provides data which are the most generally useful in the science of color. On the other hand, interest in color is often merely in regard to its appearance. The two viewpoints are, therefore, objective and subjective and, while both must necessarily be interwoven into a complete system of terminology, the latter dominates in the present consideration. Nevertheless it must be understood that analytical data, which will be discussed later, supply the solid foundation of color science and art.

*Hue.*—This is the visual quality of a color which is correlated on the physical side with the length or frequency of the predominating lightwaves with the exception of a large class of colors, called purple, which includes also such colors as pink and rose. The purples are mixtures of red with blue or violet and have no spectral match in hue. It is customary to designate the spectral hue of the complementary to the purple. In many cases the hue is directly apparent in the name of a color; however, there are a great many color names in daily use which are burdensome owing to the lack of any suggestion of the hue. The hue of a color is determined by comparing the color directly with spectral colors. If a match in hue be made between a given color and a spectral hue at equal brightnesses, in general it will be found that the two colors do not yet appear alike. The difference is accounted for by the next quality to be considered.

*Saturation.*—In general, in order to make the foregoing match perfect, it will be necessary to add a certain amount of *white* light



to the comparison spectral hue. The percentage of light of spectral hue in the total mixture of white and spectral hue is a measure of the saturation or purity. The term "purity" is misleading to many. For example, if a perfect black be added to a given pigment, the saturation or purity is unaltered; however, black naturally suggests impurity to many. A spectral hue represents complete saturation (zero "per cent. white") or a color of highest purity as considered from the physical side. The usual procedure of using the term, saturation or purity, in discussions and in measurements of determining the "per cent. white" is confusing to many persons. It is suggested that the term, saturation or purity, be always used instead of "per cent. white" and denoted by 100 per cent. minus the per cent. white. Spectral colors would then be represented physically by unity or 100 per cent. A color, which is matched by a mixture of two luminous intensities corresponding to 8 parts of white light and 2 parts of a certain spectral hue, would then have a saturation of 0.2 or 20 per cent.

In making determinations of saturation two chief difficulties are encountered, namely, a standard white light and a standard method of color photometry. Average daylight, which is considered by some to be clear noon sunlight, corresponding in spectral distribution of energy to that of a black body at a temperature of 5000°C., can be accepted as a standard white. This can be accurately matched by means of an artificial light-source equipped with a proper colored screen. However, a true physiological white is considered by some to meet certain requirements which are not necessarily met by clear noon sunlight. The flicker photometer provides a method of color photometry which at least gives consistent results although the method has yet to receive the approval of standardizing laboratories for the photometry of extreme color differences.

*Brightness.*—The third quality of a color is defined by the term brightness. The measurement of this requires a standard method of color photometry as discussed in the preceding paragraph. This quality of a color is of interest both as relative and absolute brightness. In general the relative brightness of a color, that is, its reflection or transmission factor, is of chief interest. However, it must be noted that the reflection or transmission factors of colors are not constant as in the case of neutral colors but depend upon the spectral character of the illuminant.

From the standpoint of describing, and recording appearances of colors the three factors hue, saturation and brightness are sufficient;

however, the two following terms are quite useful and complete a terminology of large descriptive power.

*Tint.*—If the hue and brightness of a color be maintained constant and the saturation be changed throughout a complete range from zero to unity, a series of tints of constant hue and brightness will result. If to a given color of high saturation, white light be added in gradually increasing amounts a series of tints of constant hue and increasing brightness will result. Tints, then, are colors of partial saturation.

*Shade.*—If the hue and saturation of a color be maintained constant and the brightness be varied by varying the intensity of illumination, a series of shades will result. In the case of pigments the addition of various quantities of perfect black results in the production of different shades of a color of constant hue and saturation.

A system of notation is one of the great needs in the art and science of color but the problem is too complicated to discuss extensively here, especially inasmuch as there are more vital problems to deal with. It is unlikely that a single system of color notation will be developed to satisfy all the requirements of the applications of color but the most promising system appears to be one which includes an accurate description of the three qualities, hue, saturation, and brightness. The scientist can supply himself with the more analytical data necessary for his purposes.

## COLOR MEASUREMENTS

It is quite outside the scope of this lecture to enter deeply into a discussion of color measurements, for such information can be found elsewhere; however, it appears advisable to describe the various methods briefly and to point out a few applications and limitations of the results.

*Photometry.*—Only two methods are of sufficient importance here to be treated. These are the direct comparison and flicker methods of photometry. For color photometry, the latter method appears to be the more desirable owing to the greater consistency of the results. It has not yet been proved that this method provides a true measure of brightness in the case of great differences in color, nevertheless it measures, with a high degree of consistency, a factor which very likely is the brightness quality of color. It does not eliminate differences due to normal variations in color vision among various persons.

*Spectrophotometry.*—The spectrophotometer, by means of which are obtained the relative luminous or energy intensities throughout the spectrum of an illuminant or of the light reflected or transmitted by a colored medium, furnishes the most analytical data. The applications of color in lighting are often dependent for success upon the spectral character of the illuminants and of the colored media used. Unfortunately such data cannot be expressed simply and cannot be readily interpreted without considerable experience, nevertheless, the lighting expert is working blindly in many cases without the aid of such data. The eye is incapable of determining the spectral character of light without the aid of proper instruments and many instances are encountered where the lighting expert has stumbled into pitfalls owing to the absence of the information provided by analytical data in such cases.

*Colorimetry.*—There are available many types of colorimeters which provide data varying considerably in analytical nature, but each has fields of application in which it is quite satisfactory. The simplest forms might be termed tintometers. These instruments are generally used for such purposes as maintaining a product within certain limits or in classifying a product according to color. A series of colors of the same hue but varying in saturation or slightly varying in hue or brightness, are provided as a series of comparison standards. Such instruments have few applications in lighting practice. Other instruments employ a mixture of two colors for limited ranges of color comparison. The resulting data are of a slightly greater analytical nature.

It is well-known that any color can be matched by a mixture of three colors, red, green, and blue, in proper proportions. By means of this tri-chromatic instrument an illuminant or colored medium can be analyzed in terms of the three arbitrary colors. There being an infinite number of sets of three colors which fulfill the foregoing requirements for most practical purposes, it is seen that the data which are obtained are restricted to the three colors used unless properly reduced to a standard system. These can be transformed into other systems but in the present state of knowledge the author has little confidence in the value of data after being subjected to such transformations. Extreme caution must be exercised in interpreting such data because the color-matches are merely subjective and therefore furnish little information regarding the spectral character of the colors examined. For instance, with such an instrument the color of the light from a quartz-tube mercury-arc is

specified in practically the same numerical terms as average daylight, although the spectral character of the two illuminants are very different.

The monochromatic colorimeter is a very satisfactory colorimeter because by means of it the three qualities of a color, namely, hue, saturation, and brightness, are determined. It has a further advantage in referring color measurements to a reproducible standard—the spectrum—although the lack of a standard and constant white causes difficulty. It should be borne in mind that those measurements are made by subjective color-matches so that the data do not provide a spectral analysis of the color which is examined.

*Spectrophotography.*—Photography of the spectrum provides a means of analyzing colors spectrally. The application of spectrum photography is usually confined to those requirements which are not so exacting although by careful procedure fairly accurate analyses may be consummated. Many variables enter, such as exposure, development, and non-uniformity of emulsion but of the greatest importance is the non-uniform spectral sensibility of photographic emulsions. Various means can be resorted to in order to eliminate the effects of non-uniform dispersion in the case of a prism spectrograph and the non-uniform spectral sensibility of the emulsion.

### COLOR MIXTURE

In many applications of color in lighting the principles of color mixture may be used. The greatest difficulties have been encountered perhaps through the confusion of the primary colors. There are three general methods of color mixture, namely, the additive, the subtractive, and the juxtapositional, although the first two are of chief importance here. Many applications of color mixture involve both methods.

As previously stated any color can be matched in hue by a proper mixture of three primary colors, namely, red, green, and blue. This method is termed additive. Many sets of primary colors can be used and a satisfactory set can be determined by experiment. In order to obtain these primary colors it is generally necessary in practice to subtract certain colored rays from the illuminant usually by colored screens. The latter is an example of the subtractive method and is the one employed in the mixture of pigments. The subtractive primaries are usually considered to be red, yellow and blue. The specification of three primaries depends upon the object

to be attained but it does not appear that there is sufficient justification for considering red, yellow and blue to be the true subtractive primaries. Purple, yellow, and blue-green appear to have a greater claim as the subtractive primaries because by mixture of these a greater range of hues is obtainable. For instance, from the former set a purple color cannot be obtained, yet in using the latter primaries nothing is sacrificed because purple is available and red can be obtained by a mixture of yellow and purple. As a matter of fact, the *red* used as a primary in the mixture of pigments is in reality a purple so that the confusion appears to arise from a misnomer applied to this pigment.

As an illustration of the difference between the two methods the mixture of yellow and blue provides an excellent example. On mixing these additively in proper proportions, white light is obtained but on mixing them subtractively green is obtained. In producing colored screens for lighting purposes, the spectral characters of the illuminant to be used and of the colored media available are invaluable guides in obtaining the desired results. Likewise this is true in many cases of the additive mixture of colored light. The juxtapositional method is well exemplified in some processes of color photography where minute colored filters, red, green and blue in color, are used in the form of rulings or starch granules. This method is of little importance in the general practice of color in lighting although there are instances where it can be used to great advantage.

#### COLOR AND VISION

The visual phenomena of color have been very extensively studied yet there remains a vast unexplored unknown. Many of the problems pertaining to color which arise in lighting practice can be solved, or at least can be better understood, by applying present knowledge pertaining to color and vision. A few of the most important phenomena are briefly described below.

*Simultaneous Contrast.*—Colors mutually affect each other when viewed simultaneously, the magnitude of the influence being greatest when the colors are in juxtaposition. The phenomena may be divided into two general parts, namely, hue contrast and brightness contrast. These two influences are usually at work simultaneously so that it requires keen analysis to diagnose a particular case. This phenomenon is perhaps the most important in the viewing of colored objects and must be credited with supplying a great deal of beauty to all vari-colored objects.

*Growth and Decay of Color Sensation.*—The various color sensations do not rise to full value immediately upon presentation of the stimuli and likewise they do not decay to zero immediately upon cessation of the stimuli. Further, the different color sensations rise and fall at different rates. Of the red, green, and blue sensations the green is the most sluggish and the blue the most active.

*After-images.*—After a stimulus of a color sensation is removed the sensation persists for some time depending upon the color. This persistence of the sensation is termed an after-image. During its decay its appearance continually changes. If immediately after the stimulus has ceased, the retina be stimulated with a moderate intensity of white light the after-image due to the first stimulus will usually be approximately complementary in color to the original sensation. Obviously the results will usually be very complicated. No attempt will be made to explain these here except by the indefinite fatigue, because the leading color theories seriously differ in their explanations.

*Retinal Color Sensitivity.*—The retina varies over its surface in its sensitivity to color. The central region is relatively less sensitive to light of short wave-lengths due perhaps to the yellowish pigmentation which has resulted in defining this region as the "yellow-spot." The extreme peripheral retina is relatively insensitive to color. The sensitive area varies for different colors and also is dependent upon the size and brightness of the colored patch which is viewed. The minimum perceptible brightness-difference is approximately constant for all colors at high intensities but differs considerably at low intensities. In general it decreases as the wave-length decreases.

*Purkinje Effect.*—The eye is relatively more sensitive to short-wave energy than to long-wave energy at low intensities than it is at high intensities. In other words, if blue and red colors appear of the same brightness under ordinary intensities of illumination, the blue will appear much brighter than the red when the intensity of illumination is reduced to a very low value. The intensity at which the effect begins to be noticeable depends upon many conditions but an approximate average is at a brightness of a white surface illuminated to an intensity of one-tenth foot-candle or of one meter-candle. This effect is best described in a few words by stating that, in general, at low illuminations the spectral sensibility curve of the eye shifts toward the shorter wave-lengths.

*Visual Acuity.*—It has been proved that visual acuity, or the

ability to distinguish fine detail, is better in monochromatic light than in light of extended spectral character. The effect is not as marked for ordinary seeing yet details, such as letters on an ordinary printed page, do appear better defined under monochromatic light. In other words, for equal discrimination or clearness of a page of type, lower intensities of illumination are required with light approaching monochromatism than with light having a more extended spectral character. Results obtained by the author using a yellow light whose spectral character could be so altered as to approach more and more toward monochromatism indicate that the increase in defining power in this case approximately offsets the opposite effect due to the attendant decreasing illumination.

*Color Vision.*—No hypothesis of color vision at the present time is in complete accord with the experimental data available. The fault obviously may lie with either the hypothesis or with the data. However, the fact is mentioned because of the tendency of those not fully informed on the subject to accept one hypothesis and to attempt to explain everything pertaining to color-vision on this basis. There are two hypotheses whose proponents have been serious opponents to each other. One of these is called the Young-Helmholtz theory. It was enunciated by Young and given considerable experimental foundation by the great work of Helmholtz. This hypothesis was builded largely from the side of physics and is, therefore, based largely upon the observed facts of color mixture. Three substances or sets of nerves which are responsible for three color sensations, respectively, red, green, and blue, have been assumed to exist, and to account for all color sensations by their varying degrees of response to different stimuli. Anatomical research has not verified the existence of those assumed substances.

The other hypothesis which ranks with the foregoing in importance is known as the Hering theory. This hypothesis has been builded largely from the side of psychology on the basis that four distinctive colors are seen in the visible spectrum, namely, red, yellow, green, and blue. Three substances are assumed to exist, the breaking down of a substance being effected by one color of a pair and the building up of the same substance being attributed to the other color of the pair. Black and white are assumed to be distinct sensations unconnected with color sensations with the result that the three pairs are considered to be red and green, blue and yellow, black and white. There is no anatomical evidence of the existence of these three substances or processes.

Von Kries is largely responsible for injecting the "rod and cone" hypothesis in color-vision theory. The cones, which exist practically alone in the center of the retina (the fovea) and become less dense toward the periphery, are assumed to be responsible for both achromatic and chromatic sensation. The rods, which predominate in the peripheral regions and are absent in the central region, are assumed to be responsible for achromatic sensations. The rods are supposed to be largely responsible for light sensation at low intensities and are in general more responsive to rays of shorter wavelengths. The cones are supposed not to be rendered very much more sensitive by dark adaptation. The rods and cones actually exist in the retina as revealed by anatomical research. Many experimental facts have been beautifully woven into this "duplicity" hypothesis.

Many interesting modifications of these hypotheses have been made and hypotheses based upon other principles are also worthy of attention. It is quite beyond the scope of this lecture to discuss the many proposed hypotheses; however, adequate treatments are available elsewhere.

#### PSYCHOLOGY OF COLOR

The great unknowns in lighting are chiefly those involving psychology which, as an experimental science is in a primary stage of development. The foregoing applies equally to the subject of color in lighting. The definite data on the psychology of color are so meager that it is difficult to treat the subject briefly, therefore, in order not to stray too far afield, only a few general statements will be incorporated here. It appears quite probable that at some future time the language of color will be understood. Occasionally glimmerings of understanding appear among the chaos of color experience yet, on the whole, there is no great amount of data to aid the lighting expert.

There is general agreement in classifying colors into warm, neutral and cold groups. Spectrally these attributes are found to lie in regular succession. Yellow, orange, and red are the regions to which the attribute of warmth is given. The cold colors are found at and near the blue region. The neutral colors are found in the central region, namely, the greens and adjacent colors and neutrality is again approached at the very extremes of the spectrum. Fairly neutral colors also usually result from an additive mixture of the colors near the extreme limits of the spectrum. Intelligent use of this knowledge can be applied to many lighting problems. How-



ever, it is necessary at this point to insert a word of caution. The lighting expert should carefully discriminate between that portion of a given condition which is predominantly responsible for the impression arising from color. In general, if the light source is visible (it may be either a primary or a secondary light-source) its color plays a dominating part in the impression upon the ordinary observer. If the primary light-sources are concealed the color of the surroundings are more effective in producing the impression than the actual color of the important surface such as a book which the observer may be reading or goods on display in a show-window. Specific examples may make the point clear. If a semi-indirect light-source bowl be of a warm color, such as orange-yellow, the observer whose æsthetic sense demands the warm color will often neglect to inquire further. In other words, the lighting will usually be satisfactory to him notwithstanding the light which constitutes the predominant part of the useful illumination may be the much whiter light emitted by a gas mantle or tungsten filament located in the semi-indirect bowl. Another example can be drawn from many installations of artificial daylight which have recently been made. Notwithstanding that a quality of daylight closely approaching daylight is, in many cases, not only desirable, but proper, tradition or habit requires that the artificial light must be of a yellowish color. If the surroundings, such as the background in a show-window or the walls and ceiling of a paintings gallery, be covered with warm colors, the white light from the artificial daylight units can be directed upon the objects to be displayed and yet the warm appearance of the whole will be largely maintained.

A room with southern exposure, which in this zone of latitude receives much direct sunlight can be "cooled" to some extent by the employment of cool colors in the furnishings. Conversely a room with northern exposure can be "warmed" considerably by the employment of warm colors in the surroundings. It is true that the light is somewhat altered by selective reflection from the colored surroundings but the major portion of the effect is often apparently purely psychological.

At this point it is well to emphasize the apparent existence of two distinct mental attitudes in regard to color in lighting. Rooms are generally decorated for daylight conditions and are presumably satisfactory when completed. However, notwithstanding all illuminants ordinarily used for general interior lighting are quite yellow in integral color in comparison with daylight, complaint is sometimes

heard of the garish whiteness of the unaltered light emitted by modern gas and electric filament lamps. The correction resorted to is usually the application of yellow screens of glass, gelatine, or silk fabric. Why, if the daylight condition is satisfactory, is the artificial lighting too cold? Obviously the question is answered by admitting the existence of day and night criteria which are widely different. The reason for the existence of these two very different criteria possibly may be traced to phenomena of vision but probably may be correctly attributed to tradition. Artificial light for ages was quite yellow and only recently have the illuminants become considerably whiter. Perhaps the demand for yellow artificial light arising from some æsthetic senses is largely due to the insistence of habit. It is difficult to account for the foregoing in any other manner considering the tremendous difference in color still existing between artificial illuminants and natural daylight. That the double standard can be partially eliminated at least, the author can testify from experience. It is not the desire here to condemn this double requirement but to diagnose it. It is a condition which the lighting expert must meet and one which involves many of the facts and applications of color science.

Colors have been characterized according to their emotional effect by such words as exciting, soothing, gay, somber, serene, and many others. In studying the attributes applied to colors by poets and painters it is found that there is apparently a general agreement in usage. However, a treatment of the subject is beyond the scope of this lecture. The emotional value of colors has been mentioned in passing with the hope that the lighting expert will avail himself, by study and observation, of the possibilities of expression through the language of color.

There are available some data on color preference, but such data must be carefully interpreted or difficulties will be encountered. In obtaining data on color preference the observer is concerned with nothing except the colors being compared. Other considerations enter into lighting problems which call for a modification of data on color preference before it can be applied. For instance, pure colors are more frequently preferred than tints and shades, a fact established by various investigators, yet this does not apply to the decoration and lighting of an interior. Of the pure colors the reds and blues are the more often preferred of a group of pigments representing the entire range of spectral colors as well as the purples. Yellow usually ranks quite low in the preference order. Strangely enough,

the colors more commonly encountered in interior decoration (cream, yellow, orange, buff, brown) generally rank low in such color-preference investigations. Perhaps, in such investigations, the momentary delight in the less common color sways the judgment oppositely to that resulting from prolonged association with the color. Certainly the warmer tints and shades predominate in interiors and usually these correspond in hue to the yellow-orange region of the spectrum.

The distribution of light, shade, and color in an interior determines the mood of the setting as a whole and often should be considered the chief factor to be studied; however, too often it is not pre-visualized but incidentally results from a certain arrangement of outlets equipped with a unit that is merely popular. Great opportunities are open to the lighting expert who learns to apply the language of light, shade, and color.

### SURROUNDINGS

As previously stated the surroundings are very important in molding the mental impression of a lighting condition. The distribution of light and shade is largely controlled by the reflection coefficients of the surroundings. Color is intricately interwoven into the whole, but, inasmuch as the psychological importance of the color of the surroundings has been touched upon, the discussion here will be confined to the modification of light by selective reflection from the colored surroundings.

A colored surface appears colored by reflected light because it has the property of reflecting light of certain wave-lengths and of absorbing others, thereby altering the incident light. A yellow wall paper reflects the blue rays only slightly, the result of subtracting blue rays from white light being a yellow light. A red fabric appears red under daylight because it reflects only the red rays in daylight. It appears a relatively brighter red under tungsten or gas light than under daylight for equal illuminations owing to the relatively greater amount of red rays present in the light from the artificial illuminants per unit of light flux. Under the light from a mercury arc lamp the red fabric appears almost black because there are present in the light from the mercury arc practically no rays which the red fabric is able to reflect. This shows that the relative brightnesses of colored objects varies with the spectral character of the illuminant and that selective reflection from the surroundings is

responsible for a change in the color of the incident light. Daylight entering interiors usually has been altered by reflection from many colored objects, such as buildings, foliage, pavements, lawns, and earth, with the result that daylight in interiors is quite variable in quality. This variation causes difficulty in accurate color work from day to day and from season to season. Skylight is much more bluish in color than sunlight so that tremendous variations in quality are apparent as the relative amounts of sunlight and skylight vary. Moreover, the variation in the relative amounts of skylight and sunlight entering windows or other openings is generally continuous.

The magnitude of the change due to reflection from colored surroundings has been measured in a miniature interior for various color combinations of the walls and ceiling and for different systems of lighting. Obviously the influence of the surroundings upon the color of the useful light at a given point such as a desk-top, depends upon the relative amounts of light reaching the point directly and indirectly. For ordinary direct-lighting systems the alteration due to colored surroundings is usually appreciable although not as great as for indirect-lighting systems. In a representative case it was found that the light from tungsten lamps in an indirect lighting fixture was altered to a color far yellower than the old carbon lamps when the colors of the cream-tinted ceiling and brownish yellow walls were of a very common combination. The effect is of considerable magnitude in semi-indirect installations depending, of course, upon the relative values of the direct and indirect components.

If in a given case of indirect lighting the artificial illuminant is too cold, it is possible to obtain the identical results by two expedients. In one case the walls and ceiling would be refinished with coverings of a warmer or yellower tint, in the other case a yellowish screen would be placed over the lighting unit so as to alter the light by selective absorption. If artificial illuminants have become too cold in color to suit the æsthetic sense, why not in many cases, resort to the use of warmer colors for the surroundings such as walls and ceiling? This method would also tend to warm up daylight in color which is very much colder than the common artificial illuminants. But here the question of the double standard enters again.

In an installation of artificial daylight it was desirable to have the lighting units appear as yellowish as possible to harmonize with the general color scheme of the room and it was also essential to have the lamps enclosed by a glass ball. This was achieved by

etching the ball inside and tinting with a very unsaturated yellow with the result that the ball appeared quite yellowish in color while the light which was approximately directly transmitted was only slightly altered in color. There was a slight loss of light due to the coloring but this was negligible in comparison with the satisfactoriness of the results. There are many important and interesting considerations which are beyond the scope of this treatment. An analysis of a given condition will reveal them.

In closing this discussion it appears profitable to enunciate a few simple but pertinent facts. A yellowish surface under daylight illumination may appear exactly like a neutral surface under an ordinary yellowish artificial illuminant. Surroundings consisting chiefly of such colors as brown, buff, yellow or orange shades, which are neutral or warm in appearance under daylight appear relatively much warmer by ordinary artificial light. In indirect and many semi-indirect systems of lighting the alteration of the light by colored surroundings is so great as to produce in many cases an effect with a modern illuminant similar to that obtained with the old illuminants in ordinary direct fixtures.

#### ARTIFICIAL DAYLIGHT

For the production and appreciation of colored objects, daylight is the generally accepted standard. The arts as well as the eye have been evolved under natural light with the result that the demand for light approaching daylight in quality for many purposes is deeply and permanently rooted. Daylight varies tremendously in spectral character so that it is necessary to determine the standards. Measurements of intensity and quality of north skylight on a clear day reveal a fair constancy which doubtless accounts for the dependence upon north skylight for accurate color-discrimination. However, north skylight varies from clear to cloudy days but not as much as the light from other points of the compass in northern latitudes. Clear noon sunlight is quite constant and although not always available represents a fair average daylight outdoors. Noon sunlight and north skylight have, therefore, been accepted as two distinct standard daylights.

There are three possible methods of producing artificial daylight: namely, (1) directly from the light source, (2) by adding complementary light in proper proportions, (3) by altering the light from an illuminant by means of a selective screen. The only available illuminant which fills directly the requirements of accurate color

work is the Moore carbon-dioxide tube lamp. Some arcs emit light roughly approximating sunlight in color but the variations in intensity, and usually in quality, have discouraged their use for refined color work. The Moore tube lamp emits light approximating skylight in quality closely enough for the most exacting color-matching.

Some years ago the light from the tungsten lamp was combined with that from the mercury arc in such proportions as to give a subjective white light. This combination met some requirements but could not possibly approximate daylight in spectral character owing to the discontinuous spectrum of the mercury arc. The spectrum of the light from the Moore carbon-dioxide tube is discontinuous but only for small intervals. On various occasions colored lights have been combined with the light from ordinary artificial illuminants to produce an approximate daylight effect. However, the only method of producing artificial daylight which up to the present has been extensively applied is that which involves the use of colored screens. These have included the use of gas mantles, arc lamps, and tungsten filament lamps.

The historical development of such units, which has been treated elsewhere, will not be repeated here in order to preserve the limited space for a discussion of the more practical aspects of the subject. Inasmuch as the author is unaware of any other extensive and diversified installations of artificial daylight, the remaining discussion of this subject will be largely drawn from records of hundreds of installations in which many tungsten filament "daylight" units of various types have been used. Excepting for the accurate north skylight units, practical considerations and requirements have played an important part in determining the final units developed. The colored screens have been made for several years entirely of glass, to comply with the requirement of a satisfactory unit.

In imitating north skylight it has proved most satisfactory to press the colored glass in the form of a plate or shallow dish in order to insure uniformity. In such cases where accurate color-matching is required, efficiency should be a minor consideration and experience has proved this to be very generally true. Using modern gas-filled tungsten lamps, north skylight of satisfactory quality is reproduced by this subtractive method at losses of from 75 to 85 per cent. of the original light. It has been found that the colored screens can be produced inexpensively and with sufficient accuracy to meet the requirements. A brief résumé of the fields in which such units are operating at the present time is presented later.

Experience has shown that, for the less refined color work and for the layman's eye, untrained in accurate color discrimination, little or no advantage is gained in correcting the light further than to an approximation to clear noon sunlight. For this reason practical artificial sunlight units have been developed. These units, whose important part consists of an enclosing colored glass envelope, have been installed for general lighting purposes in many different fields. The absorption losses of these units, using gas-filled lamps operating in the neighborhood of 18 lumens per watt, is approximately 50 per cent. A brief résumé of the fields in which sun units are operating at the present time is presented later.

Besides the preceding considerations other reasons have led to the development of a gas-filled "daylight" lamp. In the general practice of lighting a daylight lamp has usually been preferred to a daylight unit whose design conformed to the ideas of the manufacturer and whose types were limited by manufacturing expediency. There has been a constant demand for an illuminant approaching daylight in quality but of sufficiently high efficiency for general lighting purposes. For some time the daylight efficiency of artificial illuminants has been rapidly increasing. Obviously the time has been approaching when this demand could be supplied and the experiment has been tried with successful results. Other considerations hastened the culmination of this event. For example, artificial daylight is cold in appearance, although there are many applications where this "coldness" is a delightful part of the illusion. However, experience appeared to indicate at the present time a limit to the "coldness" which would be acceptable for general lighting at night in many fields. Furthermore, luminous efficiency is of some importance when illuminants are used for general lighting purposes. Therefore, there has been developed a gas-filled tungsten "daylight" lamp which corrects the light well toward average daylight, the resulting light approximating black-body radiation at a temperature somewhat below the apparent black-body temperature of the sun. It appears quite legitimate and desirable to increase the apparent temperature of the tungsten filament hundreds of degrees above its melting point by means of a proper colored-glass bulb. The color of the resulting light blends well with daylight entering interiors and has proved satisfactory in hundreds of installations. A brief summary of the fields in which this quality of light is at present used is presented later.

Various developments of artificial daylight units have been dis-

cussed herewith to illustrate the practical requirements. The discussion would apply in general as well to other illuminants besides the tungsten lamp but it has been necessary to confine the discussion to developments in connection with the tungsten lamp because these represent the first, and at present, the only developments on a large commercial scale. For the same reason the installations described later must be largely confined to the tungsten lamp. Various other light sources have been used on a small scale and usually for a single kind of artificial daylight unit. In such developments the demands, opinions, and tastes of consumers are very influential, and hence experiences have been incorporated with the hope that they will aid in future developments.

Data on the light absorption of daylight illuminants are available elsewhere. There is a lack of agreement in the results by different investigators due doubtless chiefly to the variation of the daylight standard. The absorptions presented by the author in the foregoing are those obtained by actual measurement upon units which satisfactorily fulfilled their missions.

#### SIMULATING OLD ILLUMINANTS

The development of artificial daylight units has been for the purpose of satisfying a requirement which is not generally or prominently influenced by individual taste. It has had for its object the extension of day; that is, by its use many arts can be pursued and appreciated at night as well as during the day. It provides insurance against the failure of natural daylight even during daylight working hours which occurs often especially in the crowded cities. *Æsthetic* taste has been neither a factor for nor against this development; however, the *æsthetic* taste does enter prominently into many problems of lighting. A director of an art museum in fairness to the artist and to the general public should make use of artificial daylight if economical considerations are favorable, but, an individual in his home may satisfy his taste without being justly criticized. Some of these tastes demand, for many purposes in the home, a light of a warm quality—a quality simulating that of the old illuminants. It is not a question here whether this demand is a result of tradition or the insistence of habit. The problem of the lighting expert is to appease the desire if only the individual taste is important. The increasing efficiency in light production makes it possible to alter artificial light to meet any requirements.



The problem of simulating old illuminants is relatively simple compared with the exacting requirements in the production of artificial daylight: In the former case only an approximate subjective color-match is necessary while in the latter case a close approximation in spectral character is required. Usually yellow fabric, dyes, or amber glass are used to produce the warmer color. However, the available colors if used singly are usually greenish yellow when sufficiently unsaturated as in the case of amber glass.

If a kerosene flame, or carbon incandescent lamp be concealed in a diffusing glass accessory, the color is seldom noticed. The unsaturated yellow of these old illuminants has been termed an "æsthetic yellow" in order to distinguish it from other yellows in the vocabulary of the lighting expert. Data have been obtained by many observers with various units of this character especially one unit containing tungsten lamps tinted with ordinary amber and another containing lamps colored with the "æsthetic yellow" color which produced a close match to the kerosene flame. In general the amber color was considered obtrusive while the other color was apparently unnoticed. This point is worthy of consideration in any extensive application of the foregoing.

Unfortunately no single dye is available having the desirable characteristics of high transparency, but, it is a simple matter to correct any of the common yellows of greenish tinge. This is readily eliminated by the use of a slight amount of pink coloring. Many of the so-called red coloring materials, when of light density, afford a satisfactory pink. The ordinary lamp dyes can be readily mixed to provide the proper color but these are usually more or less fugitive. If possible it is well to color a glass plate and place this at sufficient distance from the light unit. Coloring media which are very fugitive when subjected to considerable heat are often quite permanent to light when kept reasonably cool. A metal screen placed in contact with the colored screen, will often keep the latter sufficiently cool. Coloring media are available for incorporating into glass, which produce a proper unsaturated yellow color which simulates the yellow of the older illuminants, but the difficulties in obtaining a glass of the proper color and high transparency are very great.

Amber glass when very dense loses its greenish tinge but then the color is too saturated for the present purpose. However, a satisfactory approximation to a subjective match with the old illuminants can readily be obtained by combining a small percentage of the light passing through a dense amber glass with a large amount of unaltered

light. Such a procedure is not always practicable but is a highly satisfactory solution in suitable cases. A satisfactory coloring material, disregarding its opacity, for use where the temperature is high as on the bulb of a gas-filled tungsten lamp is a yellow-orange pigment used in ordinary oil painting. This can be incorporated in a suitable binder after being thoroughly ground and sifted. Good results have been obtained with yellow shellac in alcohol in which the yellow-orange pigment is thoroughly stirred although some other binders are more satisfactory. On standing, the pigment settles out but can be brought readily into complete suspension by slight stirring or shaking. Gas-filled tungsten lamps covered with this pigment have been in continuous service for many days without showing any sign of discoloring. The lamps can be dipped although it has also been found satisfactory to apply the coloring on a rotating lamp by means of a camel-hair brush.

It may be of interest to know the theoretical efficiencies of modern illuminants when screened to simulate the old illuminants exactly in spectral character. Results of computations have been published elsewhere for the vacuum and gas-filled tungsten lamps operating at various efficiencies. From these data an idea of the amount of light absorbed can be obtained. The resulting specific outputs of the vacuum tungsten lamp operating at 7.9 lumens per watt when screened to match a kerosene flame and a carbon incandescent lamp in color are respectively 4.5 and 6.3 lumens per watt. Similar specific outputs for the gas-filled tungsten lamp operating at 16 lumens per watt are respectively 7.4 and 11 lumens per watt. For the gas-filled lamp operating at 12 lumens per watt the corresponding outputs are 6.3 and 9.3 lumens per watt.

#### COLORED MEDIA

Essential tools in applying color in lighting are colored media and a knowledge of the fundamental principles of the science of color. The latter have been briefly discussed in preceding paragraphs and a few suggestions regarding colored media are presented below. Illuminants differing in color have been harmoniously blended in many instances but the greater possibilities of such applications naturally are found in installations of great magnitude. In the general practice of color in lighting an acquaintance with colored media is essential. Among the chief colored media are glasses, silk fabrics, gelatines, lacquers, pigments, aniline dyes, and chemical

salts. Often a problem can be solved very readily through an acquaintance with the availability of colored media.

Colored glasses can be obtained from a number of jobbing houses as well as glass factories. Fairly pure colors can be obtained from manufacturers of signal glasses. With little or no correction, these often afford excellent primary colors for applications of color mixture.

Colored lacquers can be obtained very readily. These are usually of two classes, one for indoor applications and the other for outdoor uses. The latter are usually colored varnishes which resist the action of moisture. Unfortunately colored lacquers are not, in general, very permanent under the combined effects of light, heat, moisture, and gases. To insure permanency it is well to flow these lacquers upon plane sheets of glass and, after drying, to protect them with glass covers. If these are installed in such a manner as to prevent undue heating, many ordinary lacquers will be fairly permanent. Ventilation is quite essential and sometimes by placing a metal screen of coarse mesh in contact with the colored screen the life of the latter can be prolonged. Lacquers can be colored with aniline dyes and other materials providing a proper solvent is employed.

Often an insoluble pigment or dye can be suspended in a binding medium to a sufficient degree to enable lamps or glassware or other media to be colored by immersion. An air brush can be used successfully in such work with the advantage that it is necessary to prepare only small amounts of the colored solution. Colored gelatines can be obtained from theatrical supply houses, a wide range of colors being available. For special purposes, and in cases of emergency, gelatine can be dyed and flowed upon sheets of glass. These are not permanent but their life can be prolonged considerably if kept reasonably cool.

Colored fabrics such as silk lend themselves to many applications of interior lighting. Colored solutions find uses especially in temporary lighting installations and in demonstrations.

The method of using these materials obviously varies with the problem at hand. If colored glasses of proper spectral characteristics are available they can be placed in such a position as to intercept the light emitted by the illuminant. However, if the correct tint is not at hand, it is often possible to obtain the desired result by combining colors according to the various methods of color-mixture. For instance if a pink glass be not available, a pink tinge

can be obtained by adding red light and a slight amount of blue or violet to the unaltered light emitted by an ordinary illuminant. This combination may be obtained by using three light sources or by using a single one. In the latter case a checkerboard pattern can be built up by means of red, blue, and clear glass; however, the light must be emitted from an extended area so that the colors are well blended. Lacquers can be used in quite the same manner. If only one lighting unit is to be used, the screen can be made by daubing on a clear glass various spots of the proper colors. However, lacquers can be readily mixed or diluted to obtain the desired color. This can be done by following the principles of color mixture. In general it should be noted that the eye cannot always be trusted to judge the satisfactoriness of a color for a specific purpose because it operates synthetically in regard to light-waves.

#### APPLICATIONS OF COLOR IN LIGHTING

It has appeared advisable to supplement the broad general treatment of color in lighting with brief descriptions of applications. Some of these will be representative of many similar cases but all have been chosen as useful illustrations of the great possibilities of color in aiding and pleasing mankind. This aspect of lighting is endless in extent and its ramifications are numberless. No strict classification will be adhered to but in general those having a more scientific basis for existence will be treated first while those involving chiefly æsthetic taste will be discussed later.

*Artificial North Skylight.*—This quality of light is the most generally acceptable for accurate color work, such as in matching and in inspecting colors. There is no need to discuss it further than to record the classes of work for which it is being used at present. It is not used for lighting large areas in the sense of general lighting although there are some rather extensive installations in existence. Artificial north skylight is at present used in the following places and occupations and perhaps in others: department stores, color printing, textile mills, dye houses, laboratories, cigar factories and stores, haberdasheries, chiropody, hair dressing, sugar testing, dentistry, painting, paint and wall paper stores, millinery shops, button factories, diamond and jewelry shops, medical examinations, surgical operations, microscopy, chemical analysis, flour mills, paper mills, garment factories, cotton mills.

*Artificial Noon Sunlight.*—This quality of light is at present quite

extensively used for general lighting in many cases where the requirements are not as refined as in the previous cases, and where eyes untrained in refined color-discrimination are involved. Among the places and occupations in which this quality of daylight is at present being used are the following: lithographing, paint shops, and stores, tailor shops, wall-paper stores, in green houses, artists' studios, art galleries, operating rooms in hospitals, paper mills, flour mills, garment factories, shoe stores, textile mills, florist shops, dry cleaning, laundries, furniture stores, undertaking, millinery shops, haberdasheries, art schools, and in illuminating color photographs.

*Approximate Artificial Daylight.*—Under this head will be discussed briefly the applications that have been made of "artificial daylight" which is only an approximation to average daylight being in reality a compromise between quality and efficiency. This discussion of the application of this quality of light, which in these particular cases is obtained from a tungsten lamp corrected by means of a colored glass bulb so that its visible spectrum closely approximates that of a black body operating at a temperature midway between the melting point of tungsten and the apparent temperature of the sun, applies to any other artificial light-source similarly corrected. The efficiency of light production has reached a point where it has proved expedient to obtain a better quality of light by sacrificing some of the light. Data are available from installations involving many thousands of lamps but only a few points will be discussed for the purpose of showing the trend in this aspect of artificial daylighting. A record of the applications of this approximate daylight includes all of the fields included under the preceding two paragraphs with the exception of the cases where very accurate color discrimination is required. Investigation shows that such a quality of light is in use for general lighting in the following places and occupations and perhaps in others: department stores, haberdasheries, cigar stores, art galleries, clothing stores, millinery shops, tailor shops, shoe stores, jewelry shops, paint and wall paper stores, furniture stores, undertaking, laundries, dry cleaning, medicine and surgery, hospitals, color printing, hardware stores, libraries, grist mills, florist shops, automobile display rooms, textile plants, illumination of color photographs, photographic studios, offices, drug stores, hair goods shops, stationary stores, barbor shops, laboratories, microscopy, grocery stores, confectionary stores, upholstering shops, breweries, hair dressing, show windows, fur stores, and in a number of isolated places. The application of this illuminant to art museums is especially worthy

of attention owing to the exacting requirements. A number of museums are at present equipped with this illuminant, notably the Cleveland Museum of Art. One interesting result has been the popularity of the museum at night. These applications of artificial daylight are sufficiently numerous and diversified to indicate that consumers are not universally satisfied to accept the accidental quality of light emitted by various artificial illuminants providing a much better quality of light can be obtained without a prohibitive loss in luminous efficiency. This is a natural result of the education of the public resulting from the activities of this society.

No further discussion of the applications of artificial daylight appears necessary in those fields which prominently involve the appearance of colors; however, artificial daylight has found its way into fields not generally expected. For instance, there has always existed a feeling of unsatisfactoriness in the lighting during the period of the day when daylight must be reinforced by artificial light. This is perhaps partially due to a difference in the distribution of light in the two cases. However, the difficulty is also partially, if not largely, due to the difference in color. Experiments with artificial daylight for desk-lighting have been quite convincing to many persons. A number of installations of approximate artificial daylight units have indicated that this is probably a large field for future development. Physiological and psychological research has yet to explore this field. Many other unique applications could be discussed to advantage but it is believed that sufficient space has been given to this subject at present. However, it has been considered profitable in this lecture to devote considerable space to this development in lighting because it represents perhaps the stride of greatest magnitude and portend in the application of the science of color in lighting that has been made recently.

*Applications of Color Mixture.*—Many diversified applications of the principles of color mixture are open to the lighting expert. The stage offers the greatest possibilities although ordinary specifications of stage-lighting often provide only clear, red, and blue lamps. It is obvious that the range of colors resulting from mixtures of these is quite limited. When it is considered that the lighting effects are valuable tools in the hands of the stage director it is wondered why facilities are not provided for using at least the three primary colors, red, green, and blue, and also clear lamps. If space permits it would be desirable to add yellow lamps. Of course, yellow could be obtained by mixing red and green but inasmuch as it is an important

stage-lighting color it appears undesirable to sacrifice it in obtaining the red and green originally and then to produce it again by mixture at a greatly reduced efficiency.

The primary colors have been used in show windows and for many special effects. One unique installation is found in a pretentious residence. Red, green, and blue lamps are installed above a large oval panel of opal glass set in the ceiling of a dining room. Any quality of light could be obtained by controlling various lamps by means of three rheostats located in a cabinet in the wall. A number of installations on a larger scale have been placed in ball-rooms and restaurants. Such applications should be more numerous considering the pleasure obtainable. A few cases have been noted where colored lights have been mixed for the general illumination of theatres, bill boards, special displays, ball rooms, etc. Flashers have usually been used but rheostats can be readily designed to be mechanically operated so as to vary the intensity of the various components by imperceptible increments. Beautiful effects have been obtained by illuminating clothing models with mixtures of the primary colors, accentuating the effects occasionally by directed unaltered light. The latter effect is intensely beautified by the colored shadows which remain due to a flood of colored light of a lower intensity than the clear directed light. Incidentally this brings out the point that colored shadows can be used in many lighting effects with wonderful success. Many possibilities of the use of color in lighting are found in interiors. Colored lights obtained by mixture provide pleasing variety and deal harshly with the monotony of ordinary lighting installations. In ordinary lighting tints are more satisfying to the æsthetic sense than saturated colors and these tints are readily obtained by adding lights, fairly saturated in color, to the ordinary unaltered light. In general it is necessary to conceal the sources. In the home the tint can easily be adapted to fit the place, the occasion, or the mood. Various possibilities can be provided in different rooms or in the same room. Moonlight, sunlight, candle-light, fire-light, etc., can be provided with ease.

Recently a moving picture theatre has been provided with a yellowish light of low intensity for use ordinarily during the projection of pictures and a bluish light for use when night scenes are on the screen. This is an example of the many possibilities of using colored light in illusory presentations.

Colored light has been used successfully in the flood-lighting of monuments, buildings, and pageants.

*Special Color Effects.*—In a few rare instances colored light has been applied to billboards and other displays and doubtless this field for colored light will be developed eventually. The play of colored light on properly painted displays is attractive and when the efficiency of light production has sufficiently increased these applications should increase in number. Special color effects have been proposed in which complete changes are produced by properly associating the colored pigments used in painting the scene, or advertising material, with the colored illuminants. These should eventually find a wide field on the stage and in displays. A few applications have been made but the difficulty at present lies in the necessity of a complete grasp of color science in order to accomplish the desired results.

*Notable Installations of Colored Light.*—A notable installation of luminants of different color and brilliancy is found in the Allegheny County Soldier's Memorial Building, Pittsburgh, in which mercury arc, Moore tube, flame arc, and tungsten lamps are woven into harmonious effect.

The applications of light and color at the Panama-Pacific Exposition are well known. This installation represents one of the greatest undertakings in lighting ever attempted and also stands as an example of the achievements that can be attained by the lighting expert who has the hearty coöperation of architects and other responsible authorities.

*Simulating Old Illuminants.*—A few applications of this character have been made but it is difficult to discuss this subject analytically because the requirements are not sufficiently exacting to demand uniformity in the developments. The results have been obtained by the use of color in ornamental glassware, of colored screens over the aperture of indirect units, of colored fabrics, and of colored lamps. Many interior lighting units approach this result by the unconscious application of warm tints to the lighting accessories. In those cases where the aim has been specifically to simulate older illuminants a common error has been made in employing an amber color instead of an unsaturated yellow as discussed earlier in this text.

*Modifying Daylight.*—A few installations of this character have been noted, the object usually being to eliminate the cold appearance of daylight by using ceiling or side windows glazed with an unsaturated yellow glass. Several notable installations are found in pretentious buildings. A satisfactory glass has been obtainable in the market. Such applications have their best field in open-



ings where only skylight enters. A specific instance was observed in an elaborate hotel where a ceiling window at the bottom of a lighting court was glazed with a yellowish glass. Other instances have been found in residences. In one case the windows in the dining room received little sunlight and the windows were glazed with a transparent yellow glass. The effect of the unobtrusive, unsaturated yellow glass was always pleasing and extremely so on dismal rainy days. Stained glass windows are colored chiefly for decorative effect but the modification of the light which passes through them often adds variety and interest to the interior.

### Bibliography

In this general lecture it has been thought best to exclude references to various investigators and practitioners who have contributed to the progress of the art because historical treatment would lead the discussion far afield; however, a bibliography of the representative work on the subject has been appended. No pretense to completeness in the bibliography is entertained, although the following references have been selected with this lecture in mind. Preference has been given to published work of recent years, to those works which include extensive bibliographies of the available material, to discussions treated from practical viewpoints, and to the availability of the publication. As a result of such a procedure and of the desire to be concise, many worthy papers have not been directly mentioned. However, by referring to the various bibliographies found in the publications actually referred to, a comprehensive view of the various subjects can be obtained.

J. W. BAIRD.—“Color Sensitivity of the Peripheral Retina.” Carnegie Inst. Pub. 1905, p. 80.

PAUL F. BAUDER.—“Reflection Coefficients.” Trans. I. E. S., 6, 1911, p. 85.

LOUIS BELL.—“Monochromatic Light and Visual Acuity.” Elec. World, 57, 1911, p. 1163.

E. J. G. BRADFORD.—“Color Appreciation.” Amer. Jour. of Psych. 24, 1913, p. 545.

E. J. BRADY.—“Daylight Glass.” Trans. I. E. S., 9, 1914, p. 937.

BROCA and SULZER.—“Growth and Decay of Color Sensations.” Comp. Rend. 2, 1902, p. 977, p. 1046.

M. E. CHEVREAL.—“Harmony and Contrast of Colors,” 1835.

J. COHN.—“Gefühlston und Sättigung der Farben.” Phil. Stud. 15, 1900, p. 279.

E. C. CRITTENDEN and F. K. RICHTMYER.—“Color Photometry.” Trans. I. E. S. 11, 1916, p. 331.

GEORGE CLAUDE.—“Neon Tube Lighting.” Trans. I. E. S., 8, 1913, p. 371.

G. W. CASSIDY.—“Art and Science in Home Lighting.” Trans. I. E. S., 10, 1915, p. 55.

JEAN ESCARD.—“Mercury arc Modified to Give White Light.” La Lum. Elec. 15, 1911, p. 236.

- C. H. FABRY.—“Color Photometry.” *Trans. I. E. S.*, 8, 1913, p. 302.
- R. B. HUSSEY.—“Arc Lamp for Artificial Daylight.” *Trans. I. E. S.*, 7, 1912, p. 73.
- E. P. HYDE and J. E. WOODWELL.—“Test of Moore Tube Installation in New York Post Office.” *Trans. I. E. S.*, 4, 1909, p. 871.
- F. E. IVES.—“Tri-chromatic Colorimetry.” *Jour. Franklin Inst.*, July, Dec., 1907.
- H. E. IVES.—“Color Photometry.” *Phil. Mag.*, 1912. *Trans. I. E. S.*, 5, 1910, p. 711; 7, 1912, p. 376.
- “Color Measurements of Illuminants.” *Trans. I. E. S.*, 5, 1910, p. 189.
- “Relation of the Color of the Illuminant to the Color of the Object.” *Trans. I. E. S.*, 7, 1912, p. 62.
- “Transformation of Color-mixture Equations.” *Jour. Frank. Inst.*, 1915, p. 673.
- “Mercury Arc Modified to Give White Light.” *Elec. World*, 60, 1912, p. 304; *Bull. Bur. Stds.* 6, 1909, p. 265.
- H. E. IVES and E. J. BRADY.—“A Gas Artificial Daylight.” *Light, Jour.* 1, 1913, p. 131.
- H. E. IVES and E. F. KINGSBURY.—“Color Photometry.” *Trans. I. E. S.*, 10, 1915, pp. 203, 253, 259, 716.
- H. E. IVES and M. LUCKIESH.—“Subtractive Production of Artificial Daylight.” *Elec. World*, May 4, 1911; *Lond. Illum. Engr.* 4, 1911, p. 394.
- BASSETT JONES.—“Lighting of Allegheny County Soldier’s Memorial.” *Trans. I. E. S.*, 6, 1911, p. 9.
- “Mobile Color and Stage Lighting.” *Elec. World*, 66, 1915, pp. 245, 295, 346, 407, 454.
- L. A. JONES.—“Color of Illuminants.” *Trans. I. E. S.*, 9, 1914, p. 687.
- F. PARK LEWIS.—“Psychic Value of Light, Shade, and Color.” *Trans. I. E. S.*, 8, 1913, p. 357.
- M. LUCKIESH.—“Light and Art.” *Light. Jour.*, Mar., 1913, April, 1914; *Lon. Illum. Engr.*, Mar., 1914; *Internal Stud.*, April, 1914; *Gen. Elec. Rev.* April, 1914; *Amer. Gas Inst.*, 8, 1913, p. 783; *Good Lighting*, May, 1912.
- “Color and Its Applications.” *New York*, 1915.
- “Light and Shade and Their Applications.” *New York*, 1916.
- “The Language of Color” (in preparation).
- “Color Photometry.” *Elec. World*, May 16, 1914; April 19, 1913; Mar. 22, 1913.
- “Monochromatic Light and Visual Acuity.” *Elec. World*, Aug. 19, 1911; Nov. 18, 1911; Dec. 6, 1913; *Trans. I. E. S.*, April, 1912.
- “Growth and Decay of Color Sensations.” *Phys. Rev.*, July, 1914.
- “Artificial Daylight.” *Elec. World*, Sept. 19, 1914; July 10, 1915.
- “Simulating Old Illuminants.” *Elec. Rev.*, July 24, 1915.
- “Color Preference.” *Amer. Jour. of Psych.*, 27, 1916, p. 251.
- “Influence of Colored Surroundings on the Color of the Useful Light.” *Trans. I. E. S.*, 8, 1913, p. 61.
- “Yellow Light.” *Trans. I. E. S.*, 10, 1915, p. 1015.
- “Color Effects for the Stage and Displays.” *Elec. World*, Apr. 4, 1914.
- “The Art of Mobile Color.” *Sci. Amer. Sup.*, June 26, 1915.
- “Artificial Moonlight Window.” *Light. Jour.*, Aug., 1915.

- M. LUCKIESH and F. E. CADY.—“Artificial Daylight—Its Production and Use.” *Trans. I. E. S.*, 9, 1914, p. 839.
- L. W. McOMBER.—“Moving Picture Theater Lighting.” *Elec. World*, 68, 1916, p. 122.
- A. J. MARSHALL.—“Use of Tungsten Lamps with Mercury Arcs.” *Trans. I. E. S.*, 4, 1909, p. 251.
- G. S. MERRILL.—“Tungsten Lamps.” *Proc. A. I. E. E.*, 1910, p. 1709.
- D. McFARLANE MOORE.—“The White Moore Light.” *Trans. I. E. S.*, 5, 1910, p. 209, 11, 1916, p. 162.
- HUGO MUNSTERBERG.—“The Problem of Beauty.” *Philos. Rev.*, 28, p. 121; *Abs. in Psych. Bull.*, 7, 1910, p. 233.
- E. L. NICHOLS.—“Daylight and Artificial Light.” *Trans. I. E. S.*, 3, 1908, p. 301.
- P. G. NUTTING.—“Monochromatic Colorimetry.” *Bull. Bur. Stds.*, 9, 1913, No. 187.
- R. FF. PIERCE.—“Artificial Daylight for Color-matching.” *Amer. Gas Ltg. Jour.*, 99, 1913, p. 68.
- T. E. RITCHIE.—“Color Discrimination by Artificial Light.” *Lon. Illum. Engr.*, 5, 1912, p. 64.
- W. D'A. RYAN.—“Lighting the Panama-Pacific Exposition.” *Trans. I. E. S.*, 11, 1916, p. 629.
- C. H. SHARP.—“Daylight Units.” *Trans. I. E. S.*, 10, 1915, p. 219.
- C. H. SHARP and P. S. MILLAR.—“An Example of Use of Tungsten Lamps to Produce Daylight Effect.” *Trans. I. E. S.*, 7, 1912, p. 57.
- P. T. WALDRAM.—“Yellow Glass to Produce Sunlight from Blue Skylight.” *Lon. Illum. Engr.*, 2, 1909, p. 472.
- M. F. WASHBURN, D. CLARK and M. S. GOODELL.—“Effect of Area on Pleasantness of Colors.” *Amer. Jour. of Psych.*, 22, 1914, p. 578.
- N. A. WELLS.—“Affective Character of Colors of Spectrum.” *Psycho. Bull.*, 7, 1910, p. 181.
- R. S. WOODWORTH.—“The Psychology of Light.” *Trans. I. E. S.*, 6, 1911, p. 437.
- “Color Photometry” (Research Com. Rep.). *Trans. I. E. S.*, 9, 1914, p. 505.
- “Lighting of Cleveland Art Loan Exposition.” *Elec. World*, Dec. 27, 1913, p. 1332.
- “The Lighting of Pictures.” *Elec. Rev. and W. E.*, Jan. 17, 1914, p. 137.
- Report on the Lighting of the Cleveland Museum of Art, *Trans. I. E. S.*, 11, 1916, p. 1014.

## CHURCH LIGHTING REQUIREMENTS

BY EMILE G. PERROT

From the very beginning light has played a most important part in the life of the world; shut out light from any living thing—plant, brute or man, and part of life itself is taken away. As light is necessary to the fullness of physical life, in like manner the spiritual life of man craves as its perfection, spiritual light.

The old law prescribed a seven-branch candlestick as part of the sacred treasures to be kept before the eyes of the people; when Christ came he voiced the need of men's souls when he proclaimed: "I am the Light of the World." As a symbol of Him, the Light of the World, the early Christians lit candles in the dark chambers of the catacombs; symbols these lights were indeed, but they served the added purpose of illumination.

So then, the architect, whether designer of lofty cathedral or lowly church, must consider light both symbolic and illuminant.

In the early centuries of Christianity, the use of a multitude of candles and lamps was undoubtedly a prominent feature of the celebration of the Easter vigil, dating, we may believe, almost from Apostolic times. Eusebius speaks of the "pillars of wax" with which Constantine transformed night into day, and other authors have left eloquent descriptions of the brilliance within the churches. The number of lamps which Constantine destined for the Lateran Basilica has been estimated at 8730. The practice of providing immense hanging coronæ to be lighted on the great festivals seems to have lasted throughout the Middle Ages and to have extended to every part of Christendom.

We, in these days of brilliant artificial light, cannot easily realize what unwonted splendor such displays imparted to worship in a comparatively rude and barbarous age. To these magnificent chandeliers various names are given, for example, cantharus, corona, stantareum, pharus, etc. Such works of art were often presented by emperors or royal personages to the basilicas of Rome.

Much more remarkable, however, are the remains of some magnificent metal work on a vast scale. The great candelabrum of

Reims was preserved until the French Revolution. It was no doubt meant to stand before the high altar in imitation of the great seven-branch candlestick of the temple of Jerusalem. Its height was over eighteen feet and its width fifteen.

No less wonderful, and happily still entire, is the great candelabrum of Milan, commonly known as "The Virgin Tree." This chef-d'œuvre of twelfth-century art is also a seven-branch candlestick and over eighteen feet in height. With such great standing candelabra as those of Reims and Milan, we may associate certain large chandeliers still preserved from the eleventh, twelfth, and thirteenth centuries. Those of Reims and Toul perished in the French Revolution. But at Hildesheim we have a circular corona of gilt copper suspended from the roof and dating from 1050, twenty feet in circumference and bearing seventy-two candles. That at Aix-la-Chapelle is still larger and still more remarkable for the artistic beauty of its details. While as a splendid specimen of later medieval work is that still preserved in the church of Aerschot, Belgium, at least until recently.

As an example of a beautiful and at the same time unique candelabrum, that in the church of Leau, Belgium, is extremely interesting, combining a lectern with the candelabrum. The chapel of the Hotel des Invalides, Paris, represents a very fine type of candle lighting, with two rows of chandeliers. The Madeleine at Paris is also a specimen of the same method of lighting.

In the early days the candle was the only illuminant, and in Roman Catholic Churches it is still required by the rubrics to be burned on the altar during Mass and other ceremonies. In the advance of science, however, religion caught the benefit and flooded its churches with the imprisoned sunlight let free from oil and coal. When later electricity was employed, religion seized the new light to serve its purpose.

That we may understand the "raison d'être" so to speak, of symbolism in the church, it will be well to consider briefly the subject of symbolism in art and the principles which underlie it, and which give it the importance it deserves. Art does not produce the real; it merely implies or suggests the real by the use of certain signs and symbols which have been recognized as equivalent. If, for example, we wish to bring to the mind of another the thought of water, we do not bring a glassful and place it before the person; we simply use the word "water," a word of five letters, which bears no resemblance or likeness to the real article, yet brings the original to mind at once.

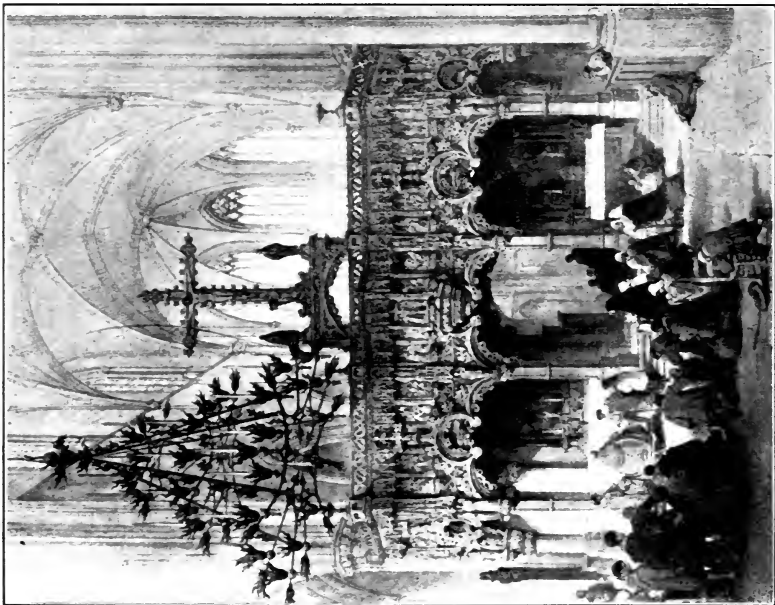

Fig. 1.—Chandelier in the church in Aerschoot, Belgium.

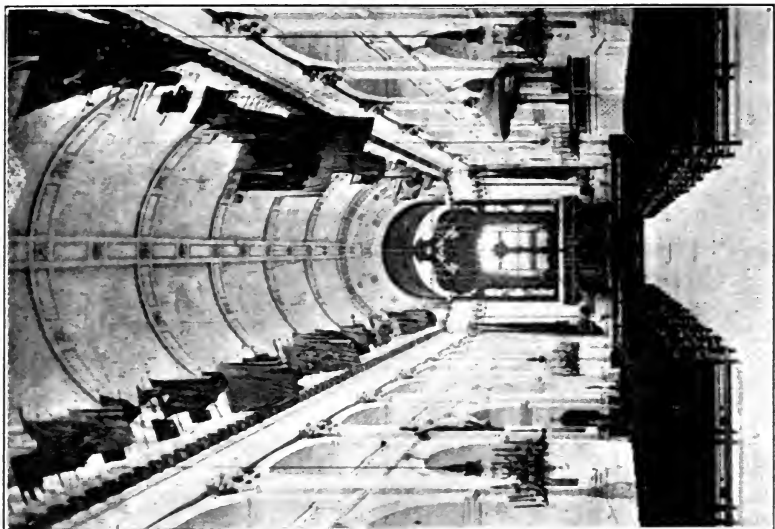

Fig. 2.—Candle lighting. Chapel of the Hotel des Invalides, Paris.  
(Facing page 298.)



Fig. 3.—Evangelical church. An excellent example of concealed chancel illumination.



Fig. 4.—Evangelical church. Good example of semi-concealed lighting. Lamps, with proper reflectors, are placed on the chancel side of the hammer beams and in the rear of the chancel.

This is the linguistic sign for water. The chemical sign for it,  $H_2O$ , is quite as arbitrary, but to the chemist represents the original as clearly as the word does to the mind of another. And only a little less arbitrary are the artistic signs for it. The old Egyptians conveyed their meaning by drawing a zigzag line up and down the wall. Turner, in England, often made a few horizontal scratches from a lead pencil to do duty for it, and in modern painting we have some blue or green paint touched with high lights to represent the same thing. None of these symbols attempt to reproduce the original, or have any other meaning than to suggest it. They are signs which have meaning because we agree beforehand thus to understand them.

Now, the agreement to understand the sign is what might be called the recognition of the convention. All art is in a measure conventional, arbitrary, unreal, if you please. Everyone knows that Hamlet in real life would not talk blank verse in his latest breath.

The drama, and all poetry, for that matter, is an absurdity if one insists upon asking, "Is it natural?" It is not natural; it is artificial, and unless the artificial be accepted as symbolizing the natural, unless the convention of metre and rhyme be recognized, one is not in a position to appreciate verse. This is equally true of music. The opera is a most palpable convention, and the flow of music which so beautifully suggests the depths of passion and the heights of romance, is merely an arbitrary symbol of reality. Recognize this and you have taken the first step forward toward the understanding of art; fail to recognize this, and art must remain a closed book to you.

Furthermore, the principle of indirectly representing by a sign the Godhead or the truths which He came to establish, had its sanction in the Divine Master Himself, for in His own public life He continually makes use of parables and indirect means to convey to His followers the divine lessons He wished to teach.

It is for this reason that we find so much use of signs, emblems, and symbolic expressions in the churches of centuries ago as well as in the ritual of the religion taught. Much might be said on this subject, but a few examples will suffice to present more clearly this phase of the subject.

In the tenth chapter of St. John we find Christ speaking in proverbs and referring to Himself as the "door."

In the third chapter of St. Matthew, at the baptism of Christ by St. John we read of the "Spirit of God descending as a dove and



coming upon Him." Thus we have Christ symbolized as a door, and the Holy Ghost as a dove. Many other examples occur in holy writ which could be mentioned in this connection, but the foregoing represent in a very striking manner the direct use of symbols to represent the persons of the Deity.

Among the symbols employed by the primitive Christians that of the fish ranks probably first in importance. The symbol itself may have been suggested by the miraculous multiplication of the loaves and fishes, but its popularity among Christians was due principally, it would seem, to the famous acrostic consisting of the initial letters of five Greek words forming the word for fish (*'ΤΧθῖς*) which words briefly but clearly described the character of Christ and His claim to the worship of believers, that is, Jesus Christ, Son of God, Savior.

The word then, as well as the representation of a fish, held for Christians a meaning of the highest significance. After the fourth century the symbolism of the fish gradually disappeared.

Referring now to the specific subject of illumination, we can consider the candle as the symbolical representation of Christ, "The Light of the World" (the wax typifying the flesh of Christ born of a Virgin mother, because of the supposed virginity of bees. The wick symbolizes more particularly the Soul of Christ, and the flame the Divinity which absorbs and dominates both).

The Christian religion, as we know it in the twentieth century, has formed itself into two great bodies, which we may term the evangelical and the ritualistic. To light a church so that the lamps may serve the practical purpose as illuminant, and at the same time keep the religious symbolism in the spirit of each of these great divisions, is the problem of church lighting that I propose to discuss.

### THE EVANGELICAL CHURCH

The evangelical church holds specially to the Scriptures, and the keynote of its service is the spoken word of the expounder of the Holy Book. So light must fill the auditorium, must center on the preacher, as symbol of the Heavenly Light that he teaches, filling men's souls.

In the other great division, a subdued light must envelop the congregation as befits those attending on great mysteries, and the light must center on the altar, shining against the darkness of the background, appearing above all else in the church, as symbol of the Light of Heaven resting on the mysteries.

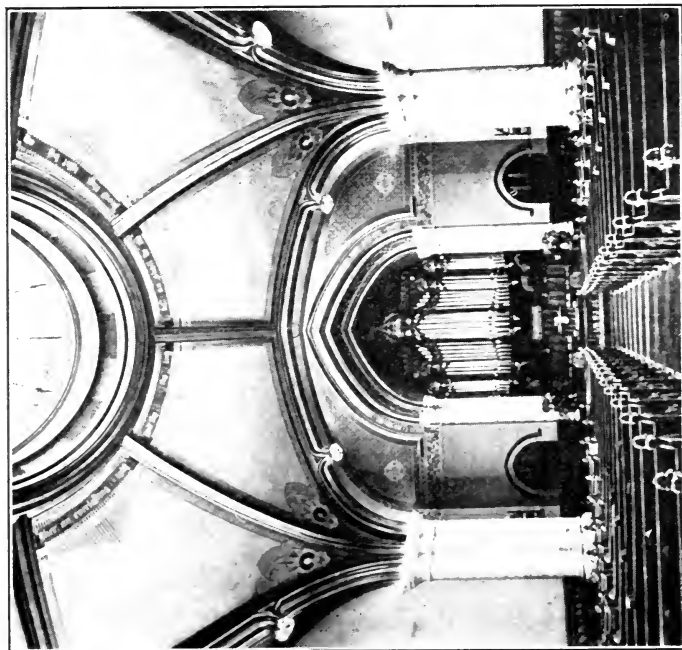

Fig. 5.—Evangelical church. Highly successful lighting scheme; electric lamps are used in the ornaments on the arches and concealed in the column capitals.

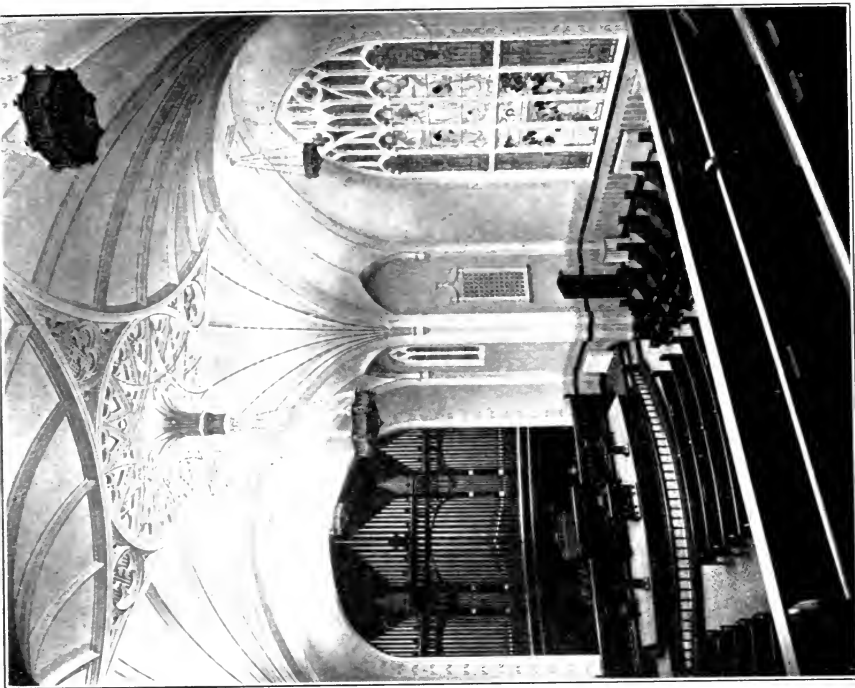

Fig. 6.—Evangelical church. Indirect pendant fixtures, harmonizing with the architectural treatment. (Facing page 300.)



Fig. 7.—Evangelical church. Excellent example of direct lighting for dark-ceilinged church.



Fig. 8.—Ritualistic church. A good example of indirect lighting by means of lamps concealed on top of cornice.

Thus we have, in general, the thought underlying the scheme of lighting for churches of both divisions.

While it may not be possible to show practical examples of lighting that exactly illustrate the principles enumerated above, yet in the main, we will find these principles carried out to a greater or less degree in all well-arranged churches. Of course, the architectural treatment of the design will influence the scheme of lighting, but the architectural scheme should follow the above principles, just as the lighting is intended to do; for instance, the plan of evangelical churches naturally takes a form best calculated to permit everyone to see and hear the speaker, hence there are large auditoriums so designed as to meet these requirements. On the other hand, the plan of ritualistic churches aims not so much to make a perfect auditorium as a place first for the altar, about which the people may gather to take part in the solemn sacrifice which is offered thereon, the part played by the speaker being second in importance to the great mysteries of the sacrifice.

Further, the ritualistic ceremony naturally begets symbolical forms in the architectural treatment, so that there are depicted throughout representations of the great mysteries of religion, both in the structural parts and in the minutest details.

As the problem of lighting evangelical churches resolves itself into that of general illumination, the treatment of such buildings can best be made to follow the general rules recognized as a standard for the lighting of auditoriums.

#### THE RITUALISTIC CHURCH

The problem of lighting ritualistic churches, particularly Roman Catholic churches, is one that requires more study since the predominance of the symbolical over the practical is very marked. There is an added problem in these churches of decorative lighting in addition to the practical and symbolic lighting. This of late years, has become very marked, due to the ease of obtaining decorative effects with the use of the many sizes and styles of electric lamps. A scheme of lighting for a Catholic Church which does not include facilities for decorative lighting around the sanctuary where the altars are placed is incomplete. While the use of candles on the altars is required by the rubrics of the church, and they must be used, the added use of electric and gas candelabra makes it possible to obtain decorative effects in light for celebrations far surpassing the effect of the candle light.

The principal reason why electric decorative lighting has come into play in this church is due to the fact that as the church proper was lit by electricity, the insignificance of the illumination of the altar by candles alone became very apparent, and as the altar is the object for which the church exists, and in its symbolical sense, should be the richest part of the church, it was necessary to add electric illumination to this part of the edifice also.

To come now to the actual working out of these principles to concrete problems, it would be well to endeavor to establish rules for guidance which can be used in most cases. The method of lighting can generally be included under one of the three systems: "Direct general illumination," "semi-indirect" and "indirect," or a combination of any two of them. In examining the general form of evangelical churches, it is found that in plan they may be grouped as follows: Square or rectangular plan, and Greek Cross plan, all usually consisting of one clear span. The church may or may not have a gallery, but as a rule, the floor area in the center must be illuminated from the high ceiling above. Usually it is preferable to hang chandeliers from points each side of the center of the building. The use of central chandeliers is, as a rule, an unhappy solution, and should be avoided unless the architectural treatment of the ceiling is such as not to permit of the use of two rows of fixtures; then the use of one row or one central fixture must be resorted to.

The lighting of the chancel should be such that ample light falls on the preacher. Should there be a chancel arch, concealed lamps around the arch produce a very impressive effect.

Should a gallery be used, the part of the church under the gallery can best be lit by ceiling lamps under the gallery, or lamps can be arranged around the columns near the caps. If there is no gallery, side lamps on the walls are sometimes necessary to supplement the light from the ceiling. There is no reason, though, why ample light cannot be arranged for in the ceiling. The one point to bear in mind is to avoid the use of naked lamps in line with the vision of the congregation. The use of brackets with naked lamps on the wall back of the chancel is injurious to the eyes of the people, and should be avoided.

Should there be a dome or window in the center of the ceiling, rows of lamps arranged to suit the architectural motives can be used instead of pendants. Daylight effect can be produced by placing lamps with suitable reflectors back of the glass.

When open truss work occurs the fixtures can be suspended from

the trusses, or else the lamps can be concealed from the congregation by being put on the chancel side of the trusses or hammer-beams.

Very effective and satisfactory results are obtained by using the indirect method of lighting. This can be accomplished in either of two ways: one by concealing the lamps on top of a cornice, or in recesses on the tops of column caps and projecting the rays upward, depending on the reflected light from the ceiling for the general illuminating effect; the other by using indirect pendant fixtures so placed as to harmonize with the architectural treatment of the ceiling, and projecting the light rays upward.

Many fine examples of this latter solution of the lighting of evangelical churches can be seen. When the artificial lighting is carefully worked out it follows closely the effects of the natural light in the daytime.

Semi-direct lighting has been developed to a point where high lighting efficiency coupled with artistic treatment have made this method very popular, since it combines in a great measure the eye comfort feature of indirect lighting, and at the same time possesses the artistic effect attendant upon the use of subdued visible light sources, for it must not be forgotten that when light is present, the eye unconsciously seeks to determine its source, and when this ceases to be a part of the decorative scheme the mind fails to get full satisfaction from the illumination.

Turning next to the lighting of ritualistic churches, the problem is more complex. As outlined above, symbolism plays an important part in the design of such churches, so much so as very frequently to determine the shape of the floor plan. The cruciform plan is the one most generally used for large churches, consisting of a nave and two side aisles across the church, and the nave transepts and apse for the three divisions of the length of the church. Of course, all churches do not have side aisles, nor do they all have transepts, but this form of floor plan is symbolically correct, as it represents the emblem of salvation, the cross.

Formerly, the common method of lighting was to arrange pendants from the apex of the main nave arches, thus making a row of chandeliers in the middle of the church. The side lamps were usually arranged around the columns or piers, sometimes in the form of a corona, and sometimes as brackets.

With the advent of electric light, greater freedom of arrangement of the lamps became apparent, hence marked progress was made by arranging rows of electric lamps in cornices or other archi-

tectural features, doing away with the need of chandeliers. However, a combination of chandeliers and cornice lamps has become very common, due to the marked decorative effect of outlining the main architectural motives by means of lamps. This arrangement was even attempted in former days with gas lighting.

A very remarkable example of semi-indirect lighting, using gas as the illuminant, is that of the Roman Catholic Cathedral of Philadelphia. The burners are of the kinetic horizontal type which makes possible the use of gas as the illuminant in bowls for semi-indirect lighting, and represent a step far in advance in the progress of gas lighting. Much study was given to the location and design of the fixtures and the results are highly satisfactory.

The arrangement of lamps about the sanctuary where the altar is placed requires the utmost care. In addition to the local lighting for the altar, it is well to arrange concealed lamps back of the sanctuary arch and pilasters supporting the same which can be lighted up at certain parts of the service to flood the altar with light; moreover, provision must be made for the decorative lighting, which changes with the seasons of the ecclesiastical year. For instance, in Catholic churches, there are certain services and parts of the service which require special lighting effects, due to the nature of the service, and whether the Blessed Sacrament is exposed or not. For grand celebrations, as at Easter or Christmas, special decorative effects in lighting and decoration with plants and flowers are resorted to. In one service of the church on Good Friday, there is a part where total darkness reigns for a few seconds, and then instantly a flow of light fills the church. While it is not the desire of the Church in any way to attempt theatrical effects, it is the intention to make the exterior signs an expression of the interior feeling one should possess in attending the service. As all of these services are to be performed in a strictly liturgical manner, it is a very delicate matter to introduce effects in lighting which will not destroy the real meaning of the service.

Before closing, I wish to call your attention to a very successful scheme of day-lighting which serves to illustrate very forcibly the proper method of using light, by suggesting to the beholder the sanctity of the place and the feeling of awe which should possess him. I refer to the tomb of Napoleon in the Hotel des Invalides, Paris. The altar is in the apse and the tomb in the rotunda. The window in the rear of the altar consists of tinted glass of a golden hue, so that the light filling this part of the interior is always bright, no



Fig. 9.—Ritualistic church. Semi-indirect lighting; two rows of fixtures. Concealed lighting back of sanctuary arch.



Fig. 10.—R. C. cathedral of Philadelphia. Semi-indirect lighting illustrating the diffusion obtained by the improved method of installation.

(Facing page 304.)



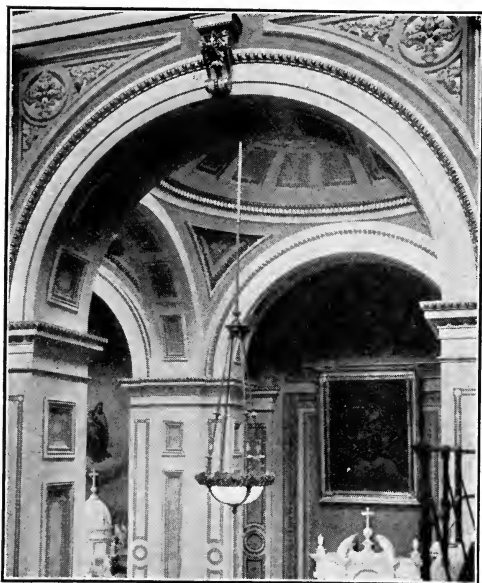

Fig. 11.—R. C. cathedral of Philadelphia. Semi-indirect gas fixture designed to conform to the interior decorations.

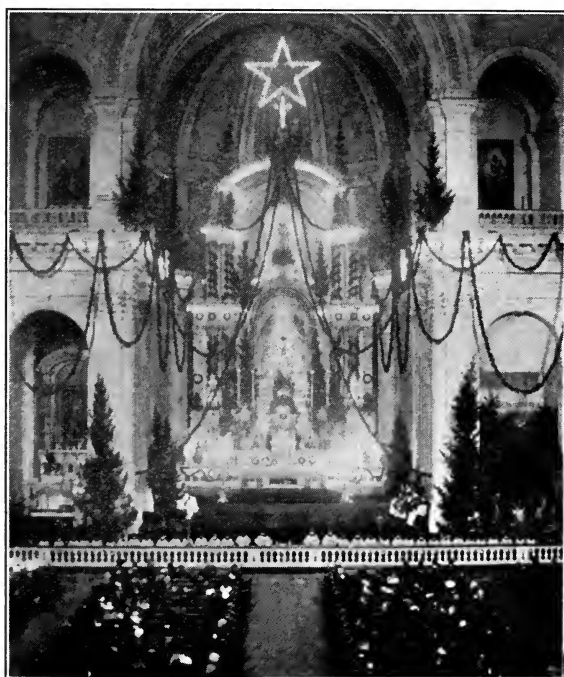
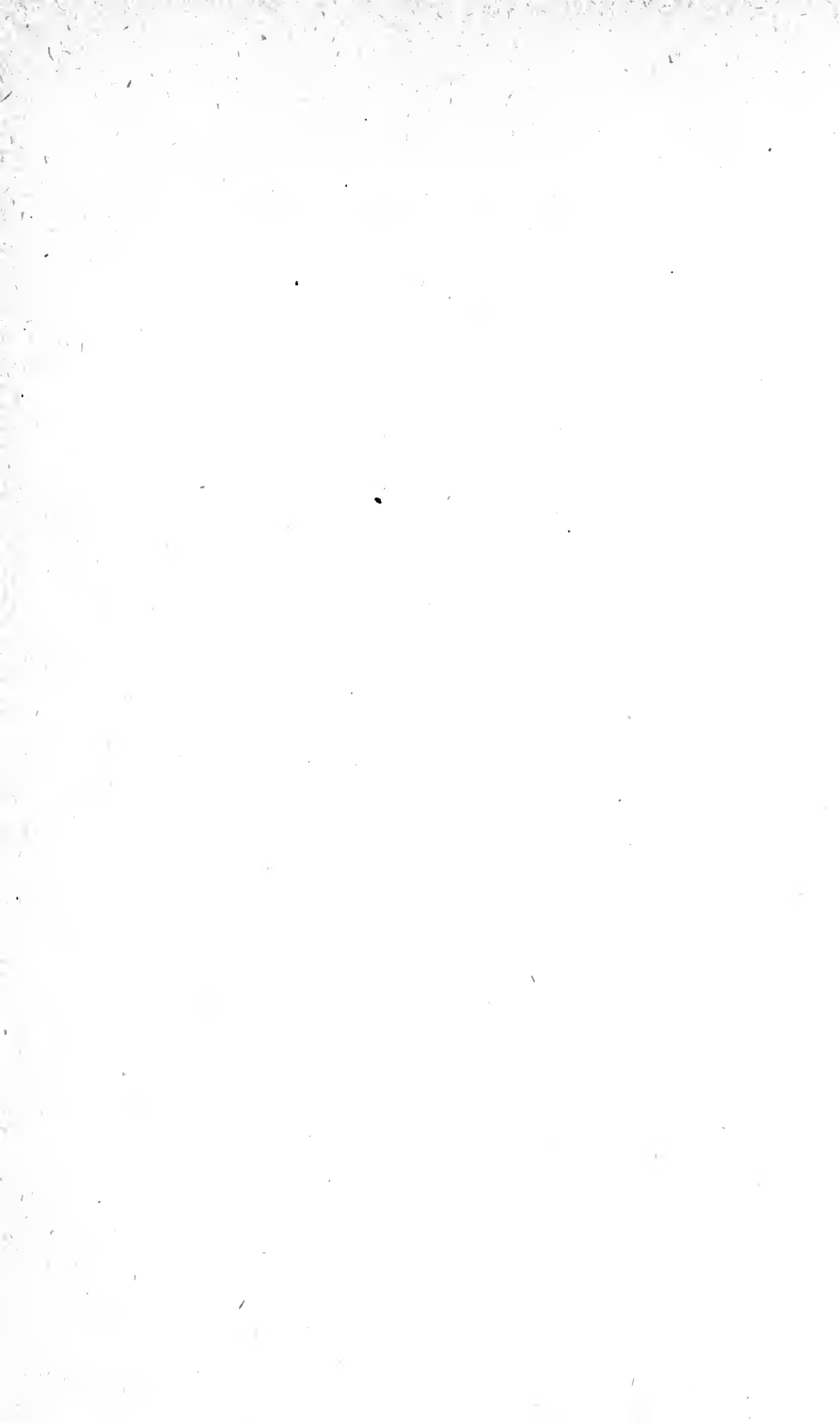

Fig. 12.—Ritualistic church. Decorative lighting for Christmas celebration. Floral and electrical effects.

matter whether the sun shines or not, thus symbolizing the living presence of God on the altar. While in the rotunda, casting its rays upon the tomb, the light no longer suggests the brightness of heaven, but on the contrary, is subdued by the blue tinting of the windows of the transepts and dome, thus reminding one that he is walking in the shadow of death.

The effect has been so thoroughly accomplished that anyone, even though claiming no pretext to the understanding of art, can readily feel the effect of the lighting as soon as the building is entered.

In conclusion it may be stated that that scheme of lighting a church is best which considers illumination in its two-fold aspect: First, eye-comfort illumination; secondly, the æsthetic, which embodies those qualities which conduce to harmony in the general architectural and symbolical treatment of the edifice.



# LIGHTING OF SCHOOLS, LIBRARIES AND AUDITORIUMS

BY F. A. VAUGHN

## INTRODUCTION

The Committee on Lectures has suggested that this lecture course should be supplemental in character to the Johns-Hopkins University course of six years ago, at which time the establishment of the basic principles on which the science and art of illumination rests, was the main object. In the following discourse, therefore, particular stresses will of necessity be placed on the progress, during the interim, of the practical application of those basic principles and on the utilization of the results and investigations and findings of the various committees of the society appointed to coördinate and apply those principles to the various practical problems, especially those involving public comfort and welfare.

Since, also, the other lecturers in the present course have been assigned subjects dealing with general details of design and application, covering the entire field of the art, the following lecture will necessarily be largely confined to an analysis of the specific problems covered by the title, the application of already established principles to these problems and a passing review of typical and notable installations exemplifying these applications.

The subject is extremely broad and inclusive, since the illumination of the various departments and divisions of schools, auditoriums and libraries, embraces practically every known type of illumination, for all classes, ages and sexes of people. This discourse must therefore be confined within limits, lest it overlap the subjects of the other lecturers; therefore it will treat fully only those requirements which are more or less uniquely applicable to the narrower interpretation of the subject, leaving the applications to the more general functions to others, or to casual mention. For instance, in the modern schools and colleges there are offices, catalogue files, dining rooms, gymnasiums, swimming pools, shops, kitchens, hospitals, grounds and architectural exteriors, which require practi-

cally the same treatment as the same character of spaces in other establishments.

In the formation of this somewhat narrower viewpoint it will be assumed that the more unique functions of the three divisions of the subject will be largely confined to education, edification and amusement, especially studying, reading, observing and listening. For the purpose of this lecture, the principal function of the schools will therefore be considered to be a public place for study; that of the library, a public place for reading, and that of the auditorium a public place for seeing and hearing. In each case large masses of the public are involved, and each is a factor in the education, edification and amusement of the public, with a preponderance toward the educational or amusement functions in the order given. All are fundamentally of general public benefit, welfare and uplift, if properly used, and all deal with comparatively large spaces, accommodating numerous people.

Surely, it is tremendously important to pursue the study of the proper application of the art of good illumination to these spaces as a means of augmenting the beneficial functions of these institutions, and of avoiding the counteracting influence of the serious ill effects of poor illumination on the physical, mental and moral development and well-being of the public.

Besides being useful and efficient, it is demanded of the lighting installation in each of the divisions that it be artistic and harmonious. This requirement is at present perhaps most rigid in the case of auditoriums; less so in the case of libraries, and still less in the case of schools, with a growing tendency at the present time to introduce and extend this influence more and more into the schools, not in the form of elaboration or ornateness, perhaps,—which is not necessarily art;—nor in an expensive form—which does not always indicate good taste—but by the harmonious application of the installation to the architectural features and the functions of the room. In each division of this subject, the importance of the physiological effects as obtained through vision and the use of the eye, is tremendous, and more and more widespread in its scope as we pass backward toward the schools, where the development and conservation of the eyesight of our children and youths for the future is paramount and of greatest economic importance to the nation and the world. In the other two divisions, however, the conservation of the remaining eyesight of older persons is only relatively unimportant.

In each division it is desirable, for the successful carrying on of

the functions of that institution, to produce certain psychological effects, exemplified by the quietude of the library, the attitude of concentration in the schoolroom, and the inviting, pleasant and comfortable atmosphere of the theatre. The steady, daily repetition of concentrated study in the schools is particularly conducive to eye fatigue and strain, and makes the application of proper, comfortable illumination in schools more important than does the casual frequenting of the library or amusement auditorium, which are still respectively important. The problems, therefore, while similar in many respects, are quite different in others,—the similarities and differences, from the standpoint of the following basic requirements set forth by L. B. Marks in the 1910 Lectures, and their different gradations, being more or less apparent.

These fundamental characteristics of good lighting then established are:

1. Sufficient illumination.
2. Low specific brightness.
3. Freedom from glare.
4. Diffusion.
5. Cost of installation.
6. Economy of operation.
7. Simplicity and convenience.
8. Æsthetic design.

In schools, the business of concentrated study for the attainment of mental development and education has tended to minimize the æsthetic side. In the library, a place for study and reading, for all classes of readers of various ages and conditions of eyesight, and developed and undeveloped æsthetic attitudes, particular attention must be paid to the difficult problems affecting eye efficiency and comfort in connection with the use of books, new and old, in all types and on all grades and conditions of paper. Less of the element of slavish work, more of the element of recreation and entertainment enters into the use of libraries, where reading is done for education, information and amusement, and there is more inclination and opportunity for the observation of the æsthetic factors in the installation. Auditoriums—which the dictionary defines as “The part of a public building, as a theatre, occupied by the audience; hence any space so occupied”—are principally used for purposes in which the recreation and amusement of the public predominate, with a still greater inclination and tendency to observe and benefit by the æsthetic factors. No study and very little reading is pursued

here; the main function being that of listening with the eyes open, and therefore still subjected to the good or bad effects of the illumination. Auditoriums used as concert halls, churches, lodges or even expositions, still retain a large educational element, although in varying degrees, and it is thus apparent how these divisions of the subject are inter-related.

The illumination requirements may be, for good and sufficient reasons, lively or subdued; brilliantly glittering or dull; intensity high or low; diffusion more or less; installation simple or elaborate; expenditure spare or lavish; operation economical or expensive; but the architect and engineer must produce a harmonious solution of the specific problem, which is compatible with the results desired.

Schools, auditoriums and libraries all perform very important general public service in the education and uplift of the commonwealth. Notwithstanding the differences in the classes and ages of the users; in the educational or amusement features; in artistic, æsthetic or psychological aspects—the physiological aspects are the same in all, in so far as conservation of vision to the greatest extent and for the longest period is of main importance, beginning with preventive measures in the young and ending with preservative measures in the older. Even in schools for the blind, where at least some of the inmates, including the teachers, still retain a precious remnant of their vision, it is perfectly apropos to give most careful consideration to the planning of the illumination.

Different intensities are, of course, required for sufficient illumination of the different classes of interiors and for the different purposes for which they are used. During the daylight hours, the intensities are relatively high, although very fluctuating, and if carefully planned, the natural illumination is well diffused, though oftentimes definitely directed. Different intensities may be best for young eyes or old eyes. In theatres and lodges, the intensity is under the control of an operator and may be adjusted according to the effects desired by the stage director or required by the lodge services. In churches, there may be differences in intensity desired by different denominations, as well as for different congregations and services, the reading services of the Christian Science Church having set a relatively high standard of intensity for church illumination, for instance. The more subdued interiors of some of the Gothic churches require a more subdued religious atmosphere. An example of a peculiar requirement in a church during war times is of passing interest, where, because of the Zeppelin air raids, a London church is required

to darken the top of its auditorium entirely by means of opaque downward directing reflectors.

The selection of fixtures for various interiors and requirements is a most important function, best performed through the coöperation of the building committee, the architect and the illuminating engineer. Coöperation with the architect, which, since the year 1910, has made great progress in our profession, cannot be emphasized too forcibly, for where an able architect is retained, the best general effects can be obtained with his coöperation; for the problem of the illuminating engineer is not so much the selection of the proper fixture design as the selection of the proper system and type, quality and quantity of illumination, although every engineer who assumes to deal with these problems should conscientiously train his latent artistic faculties, so that when loaded with the responsibility for the æsthetic features of an installation he can perform this function in a manner beyond the ridicule of the architect and with credit to his profession, and so that his engineering ability will not be driven into oblivion in the shadow of artistic criticism.

Given by the architect certain architectural and æsthetic features, such as Gothic design; dark decorations; dull colored ceilings; certain artistic effects and color schemes, the illuminating engineer must first select the system of lighting and type of installation best suited to these conditions, and the two collaborators may then work out a combination of art and science in the form of the fixtures, the artistic outer garment being designed by the architect with sufficient dimensional and spacial features to contain properly the utilitarian apparatus, such as the reflectors, lamps, etc. The selection of fixtures or their design will not be specifically treated in this lecture, as the illustrations will be sufficiently indicative and in the majority of cases, the reason for this selection, often confined to designs obtainable generally on the market, will be apparent.

#### PART I.—SCHOOL ILLUMINATION

Because of the present general appreciation of the hygienic importance of sufficient and proper illumination in schools, it hardly seems necessary, except possibly to add emphasis, to make any statement regarding the tremendous service which the illuminating engineer can be to the present as well as future generations, by his unstinted activities in this phase of the art of illumination. Because of its preponderant importance, the major part of the discussion in this lecture will be devoted to a review of accomplishments in this



direction and of suggestions for future accomplishments. Within the past five years, not only has the interest of the Illuminating Engineering Society been awakened through its individuals and groups of members, but the active and productive interest of many school committees having charge of hygiene, sanitation, conservation of vision, selection of textbooks, and like important matters, has been aroused, with the practical results of the recommendation and adoption of several codes and rules tending toward the elimination of the ill effects of bad lighting in our schools through the improvements in illumination and otherwise. A committee of the society, having in charge the preparation of a "Code of School Lighting," is practically ready to submit for general adoption a splendid compilation of scientific and common-sense suggestions, the general adoption and enforcement of which would be of inestimable benefit to mankind. Mr. M. Luckiesh, the chairman of this committee, last year discussed these matters in his paper on "Safeguarding the Eyesight of School Children," and much of the text and some illustrations which follow in this division are excerpted from his presentation, and the tentative compilation of a code prepared by the committee.

As exemplifying the present active interest in this subject, outside of the society, two typical references may be made, one from "Sanitary School Surveys as a Health Protective Measure," by J. H. Berkowitz, published by the New York Association for Improving the Condition of Poor;" and one from "Recommendations Adopted by the Board of Superintendents of New York Schools," both dated this year. The first reference is as follows:

"In no other respect is the teacher's responsibility for the physical well-being of the pupils better defined than with reference to the protection of eyesight. Posture is important, of course, and the proper adjustment of desks and seats is a controlling factor in maintaining it. Eye-strain is closely associated with incorrect posture, and likewise caused by poor seating arrangements.

"Height of desk and seat, distance from each other, distance from blackboard, etc., are some of the factors to be considered in relation to eyesight. The prevention of glare from excessive light and reflective surfaces is of the utmost importance, and yet perhaps the easiest to attain. The proper means being provided, it rests entirely with the teacher. Perhaps the function of window shades and their usefulness are not fully appreciated, but teachers should know that glare and intense direct light cause eye fatigue. This is particularly harmful to the immature and highly susceptible eyes of children.

"Unfortunately, in most of the classrooms surveyed the testimony found is against teachers and others responsible for the welfare of the pupils. Torn, unworkable window shades, particularly in classrooms, which give an unobstructed exposure to the rays of the sun, are a menace to children. Aside from the necessity of proper manipulation of shades for the regulation of light, the simple obligation is imposed on the teacher to report promptly any damage which may effectively interfere with the proper use of such shades.

"The school authorities can be expected to correct defects only if they are brought to their attention."

The second reference cites rules prepared by Dr. I. H. Goldberger, Assistant Director of Educational Hygiene, for the Board of Superintendents.

"There are scores of classrooms in the public schools that are poorly lighted. The women principals have been working for years to have these rooms closed, but without result. Usually they are in buildings which are congested and all available space must be used. The conditions are recognized as serious and to counteract the ill-effects of studying and reciting in such rooms the board of superintendents has had prepared the following recommendations for the guidance of teachers in such rooms as are insufficiently illuminated:

"1. Artificial illumination should be used whenever necessary. No rule can be laid down to guide the teacher in this matter. She must use her own discretion and judge when artificial light is necessary. It must be used at once if pupils exhibit any difficulty in reading.

"2. Teachers should be alert to report to the principal if the windows, walls, or prismatic glass reflectors are not clean.

"3. Dark-colored pictures should not be hung on the walls, and dark-colored charts should be displayed only when necessary, for these diminish the light in the classroom.

"4. Teachers should refrain from placing curtains or any other obstructions in the window.

"5. Window shades should be kept rolled up as much as possible. Attention should be paid to the proper regulation of the shades, protecting the children's eyes from insufficient or excessive light.

"6. To favor the maintenance of the proper reading and working distance, pupils should be seated so far as possible at desks according to their size. Janitors are under the by-laws required to make adjustment of furniture upon instruction from the principal. Children having defective vision should be seated as near as possible to the front of the room.

"7. The eyes should be raised occasionally from the work, and there should not be two consecutive periods of close eye work."

If boards and individuals having the responsibility of the solution of these problems are making such sincere and effectual efforts,

surely the Illuminating Engineering Society and its members who are specializing in this work can be of great assistance through the adoption of a code of school lighting, and by the further promulgation of the correct basic principles through the Society, reciprocal meetings with other societies, and by other coöperative means. The problem exists to-day, in several thousand schoolrooms, affecting millions of children. A remedy should be speedily applied. It is a matter for most hearty congratulation that it is actually being done.

A full consideration of the subject of illumination in schools must include illumination by daylight, which, because of its close relationship to the design, location and position of the building, requires the intimate coöperation of architect and engineer.

The orientation of the building, as well as the arrangement of the ceiling and side windows, and other openings for admitting daylight, should be so planned that direct sunlight, for at least a portion of the day, enters the classrooms and other important portions of the building. The order of preference of exposures is given by the Code as easterly, southerly, westerly and northerly. There should be sufficient light in the darkest working space and as good uniformity as possible everywhere. The minimum daylight intensities proposed are as follows:

	Illumination in foot-candles	
	Minimum	Desirable
Storage, passageways, stairways, etc.....	0.5	0.5- 5.0
Classrooms, study rooms, libraries. ....	4.0	4-20
Auditoriums.....	3.0	3-10
Sewing, drafting, etc. ....	10.0	10-30
Blackboards.....	4.0	4-20

On account of the difficulty of control and regulation of daylight, actual or average working intensities cannot be readily established, but the ceiling and side window shades and curtains should be of such optical and mechanical characteristics and be so maintained and operated as always to keep the illumination well above the minimum set forth and to protect the children's eyes as much as possible from glare. The daylight intensities will, of course, generally be higher than by artificial illumination. Daylight illumination should be unilateral. It should not enter the classroom

from the right, but should enter from the left, with a minimum window area, ordinarily, of not less than one-fifth of the floor area. Windows in the rear may produce glare upon the blackboard, and therefore should be regulated with care.

Natural lighting through wired glass windows in the ceiling may be superior, but the architectural difficulties usually prohibit this method from adoption in as many cases as would be desirable. Lighting from side windows can be brought nearer to ceiling window uniformity, by attention to their proper proportion to floor area and effective visible sky area, and by the scientific use of prismatic and other forms of diffusing and directing window glass, and by the construction of relatively narrow schoolrooms, with high windows and highly reflective surroundings.

With artificial illumination, as high intensities cannot be economically obtained as with daylight, nor are they required, and the following average intensities have been recommended.

	Illumination in foot-candles	
	Minimum	Desirable
Storage corridors, stairways, etc.....	0.25	0.25- 5.0
Rough shop work.....	1.25	1.25- 2.5
Fine shop work.....	3.5	3.5 - 6.0
Sewing, drafting, and the like.....	5.0	5.0 -10.0
Auditorium.....	2.0	2.0 - 4.0
Classrooms, study rooms and libraries....	3.0	3.0 - 5.0
Gymnasium.....	1.0	1.0 - 5.0
Laboratories.....	3.0	3.0 - 5.0
Blackboards.....	3.0	3.0 - 5.0

Sufficiency of illumination, which is the prime factor, can be secured by any one of the three general arbitrary types of systems of illumination known as direct, semi-direct, and indirect. Some of the other important factors, however, may be best produced only by one system or another. Greater diffusion can be obtained by larger indirect component, while definiteness of control can be obtained by the direct system with properly selected reflectors. Through the exhaustive work of Drs. Ferree, Rand and Nutting, J. R. Cravath, A. J. Sweet, T. W. Rolph, and others, the relative advantages of the various systems with relation to eye fatigue and ocular com-

fort, have been so thoroughly investigated and discussed as to need no repetition here. Since diffusion, as obtained by the indirect system, tends to minimize the glare from the light sources, and from the desks and furnishings, as well as from the pages of the books, the indirect is preferable to the direct system. Since the semi-indirect system is intended to be merely an intermediate between, or combination of the direct and indirect, it may possess more or less of the advantages or disadvantages of either system, according as the particular installation possesses more or less of one component or the other. Good results can be obtained by the use of translucent bowls if the brightness of their surfaces—which means the direct component of illumination which passes through the glass—be kept down, thus producing really an indirect installation with relatively faintly luminous bowls. In this way the semi-indirect is merged into the indirect.

Localized illumination has no place in the solution of this problem. Approximate uniformity on the working plane, is highly desirable and could not be obtained thereby. Light sources must be kept out of the range of vision, and, especially in the direct system, should be relatively small in size and large in number and should never be visible against a dark background. Bare lamp filaments must be shaded, screened or concealed. This is particularly necessary when the modern extremely brilliant lamps are used. Luckiesh states that the brightest permissible object visible from any normal position of the observer should be not greater than 250 milli-lamberts with a maximum permissible brightness contrast in the normal visual field not greater than 20 to 1. The Committee on Glare of the Illuminating Engineering Society, in an effort to establish these and similar standards, compiled several reports during the last year treating very thoroughly the subjects of brightness and glare.

Other committees of the Illuminating Engineering Society have established a contrast ratio of 100 to 1, to apply over the whole working space. The above ratio of 20 to 1 should be interpreted as applicable to juxtaposed surfaces.

It should be stated that all wall areas, ceilings, and other reflecting surfaces should be matte; the ceilings bright, especially for indirect systems, and the walls only moderately so; the general idea being to avoid great contrasts, mental depression and poor efficiency.

A matter of almost as much importance as all that has thus far

been stated is the character of the surfaces at which the children have to look and with which they have to work, especially that of the paper used in the school books. A great amount of attention has been given to the subject of glare from the pages of school books and sufficient interest has been aroused to insure the future adoption of paper with sufficiently matte surface to minimize specular reflection and resultant glare and to assure the selection and use of comfortable reading type, form of letter, spacing of lines and letters, and the use of suitable qualities of ink.

Well-diffused uniform illumination from and on matte surfaces, and produced by screened or concealed sources, minimizes glare and contrasts and is conducive to ocular efficiency and comfort.

Glare, as clearly defined and analyzed in the various reports of the Committee on Glare of this year, is the omnipresent bugbear particularly of school illumination. After its reduction by concealing or screening the light sources; properly locating and proportioning the windows; using matte reflecting surfaces, unpolished desks, and especially prepared book paper, it still lurks on the surfaces of the blackboard. Mr. Luckiesh, who treats this subject simply and plainly, states that:

“Glare due to specular reflection from glossy blackboards can be reduced or eliminated by lighting them by means of properly placed and well-shielded artificial light sources. In Fig. 5 in Mr. Luckiesh's paper on “Safeguarding the Eyesight of School Children”—page 181 of the Transactions of the Illuminating Engineering Society, Nov. 2, 1915 are shown simple graphical considerations of blackboard lighting. In *a* is shown a plain view of a room with windows on one side. Rays of light are indicated by *A*, *B*, and *C* in a horizontal projection. These are supposed to come from the bright sky. By the application of the simple optical law of reflection—the angle of incidence is equal to the angle of reflection—it is seen that the pupils seated in the shaded area will experience glare from the blackboard on the front wall. In *b* is shown the vertical projection of the foregoing condition. It is seen from this graphical illustration that by tilting the blackboard away from the wall at the top edge the pupils in the back part of the room will be freed from the present glaring condition. Whether or not this tilting will remedy bad conditions can be readily determined in a given case. In *b* the effect of specular reflection of the image of an artificial light source is shown by *D*. In *c* is shown a proper method of lighting blackboards by means of artificial light sources. This will often remedy bad daylight conditions whether due to an insufficient illumination intensity of daylight or due to reflected images of a patch of sky.”

The psychological as well as the physiological relation of colored illumination to the hygienic, as well as to the æsthetic, conditions in schools and other places of intensified and concentrated visual operations is important and has been thoroughly investigated by Mr. Luckiesh and referred to by Messrs. Black and Vaughn, and others.

The editor of the *Illuminating Engineer* once said:

“Lighting installations, like men, may be notable for defects as well as virtues. They have this also in common with men, that they are seldom hopelessly bad or perfectly good.

“Careful observation, retentive memory, and a habit of analytical reasoning are the basis upon which experience builds the structure of skill which is above rules and formulæ.

“An impartial study of different lighting systems, with a view to frank criticism and comparison is one of the best of all methods of acquiring facility of judgment.”

With the spirit of these remarks in mind, let us now analytically review several illumination installations exemplifying the good and bad features discussed above.

For instance, a school room is improperly illuminated by daylight when the light is admitted mainly from the right-hand side, as shadows of the hand and arm are thrown on the working plane. This produces illumination which will result in eye-fatigue. A school room with proper daylight illumination is one in which the light is admitted from the left side and the rear, as this gives as nearly a perfect arrangement for maximum high efficiency as it is practical to obtain without ceiling windows.

In Fig. 1 (Fig. 7 of Mr. Luckiesh's paper, “Safeguarding the Eyesight of School Children,” above referred to) is shown an extremely bad condition, found in a schoolroom where drafting is taught. With such localized type of lighting each pupil can adjust the unit to suit himself, with the result that he is not only injuring his own eyesight and doing poor work on account of misdirected light, but at the same time is subjecting many other pupils to bad light conditions, on account of the position of his lamp. Actual inspection in this case, Mr. Luckiesh says, showed that most of the pupils were using the light improperly and were often working in such a way as to produce annoying shadows.

However, a condition which is even worse than that in the drafting department just shown is one where the lamps are suspended from cords, as, with the type of angle steel reflector in popular use, the lamp is always exposed to the view of anyone on the opposite side

of the reflector. Due to the fact that cords are used, the lamps do not stay in any fixed position, but have a tendency to swing back and forth on account of air currents or when hit by the students, so that the light proves very unsatisfactory, as is always the case when lighting equipment is used in such a way as to permit of adjustment by the individual.

In Fig. 2 is shown a drafting or drawing room in which use is made of the indirect system of lighting. It is to be noted that all of the table tops are brightly and yet uniformly lighted, and, due to the large expanse of lighted ceiling, no shadows are encountered by the draftsmen when working.

In the manual training department of a modern technical high school (Fig. 3), localized lighting is used in the wood-working shop, where angle reflectors with bare lamps are employed. It was noted that one of the lamps had been tied up in order to obtain a more desired (though not necessarily desirable) illumination, and that in another cord a knot had been tied evidently for a like purpose. A student working on any of the benches would have the glare from the exposed lamps of all the various units. A view was taken in the daytime, with the lamps used just long enough to show the location of the bulbs. It would have been impossible to have taken a satisfactory picture entirely by the light of the units, since nothing would have shown except the lamps themselves and a small portion of the bench directly in front of them.

In the wood-working machine shop (Fig.4), the illumination is furnished by direct units with mirrored glass reflectors with opaque green enamel backing. The effect is to give an even illumination over all the benches; at the same time so screening the light sources as practically to eliminate all glare unless a person deliberately looks up into the reflector. It may be pointed out here that while it is perfectly plain and well known that by the multiplicity of units per unit of area greater uniformity of intensity of illumination and greater dispersion of shadows can be secured, it may not be so apparent to all that the same tendency obtains with the indirect system and that sometimes numerous indirect fixtures may be used in a given area and sometimes few, according to the results demanded and the funds available. The higher grade distribution can be secured with few fixtures, if proper selection of reflector, lamp, position and hanging length is obtained, so as to distribute the light as uniformly as possible over the ceiling.

In the sewing room of a domestic science department in a public



school (see Fig. 12, Luckiesh's paper "Safeguarding the Eyesight of School Children"), steel reflectors suspended on flexible cords have been used with the result that bare lamps are constantly within the direct range of vision of the pupils, giving the worst possible conditions for working.

The domestic science room in a high school was, again, so furnished with improper daylight lighting that those working on one side are in their own light with the windows at their backs; those on the other side of the table get the full glare of the windows in their eyes; while those at the far end of the room have the light coming in from the right-hand side, and only a few can secure whatever advantages there may be in this position—the whole arrangement being very unsatisfactory. The tables should be so arranged at right angles to the windows that at least the largest possible number receive the daylight from the left. On the other hand, the interior of a model economics class kitchen in a college was so illuminated artificially as to result in absolutely uniform illumination on the stove, table and kitchen cabinet, with entire absence of glare. This was accomplished by means of the indirect system of lighting which has the advantage that, no matter where a person is at work in this room, very little shadow will be occasioned by his or her position.

In contradistinction to the above, one usually finds in a university chemical laboratory, for instance, old types of lighting in which the daylight conditions are very nearly as poor as those of artificial illumination. What the effect in these rooms is at night is known to most of us from experience. The usual very low mounting height and the general type of reflector used, its design evidently being based on uniqueness of outline rather than on the principles of reflection or eye efficiency and comfort, make this usual plan almost unbearable.

A notable grateful exception to the above method of illuminating school work rooms is found in the chemical laboratory in the Boy's High School at New Orleans. The photograph of Fig. 5, taken at night, shows conditions with artificial illumination. Being lighted by the indirect system, there is uniformity of illumination and absence of glare and shadows which is desirable for a room of this character.

It may be interesting, for the sake of emphasis, to inspect one or two examples of typically bad schoolroom lighting as it exists to-day in many of our larger as well as smaller cities, where the millions of school children are subjected to the deleterious influence of eye-fatiguing installations.

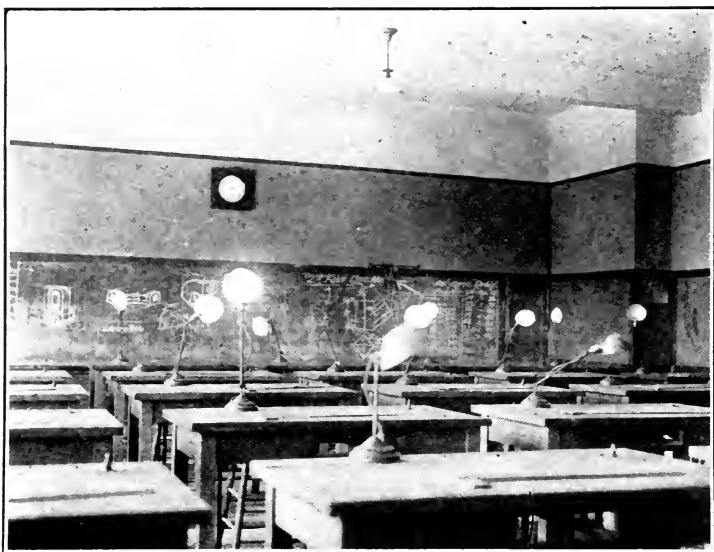

Fig. 1.—A poor arrangement with localized, adjustable lighting equipment in a drafting room.



Fig. 2.—A drawing room properly illuminated by a totally indirect system, with simple opaque fixtures.

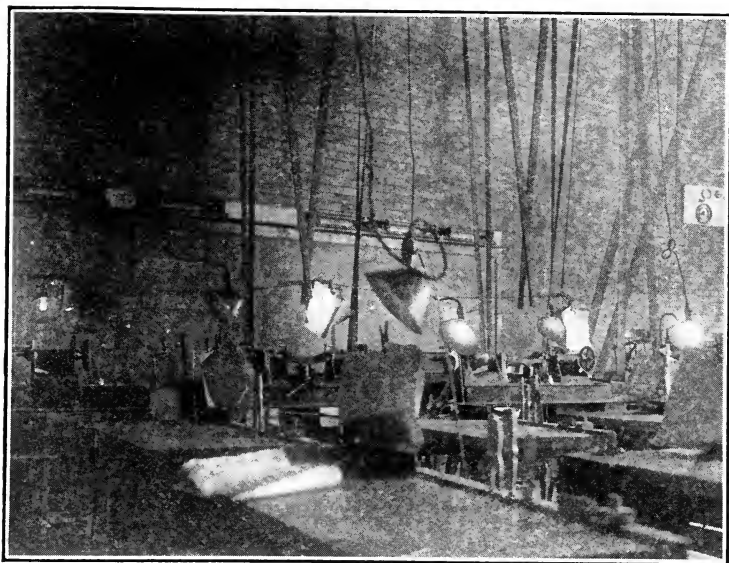

Fig. 3.—Manual training department of a school with very poor arrangement of localized lighting.

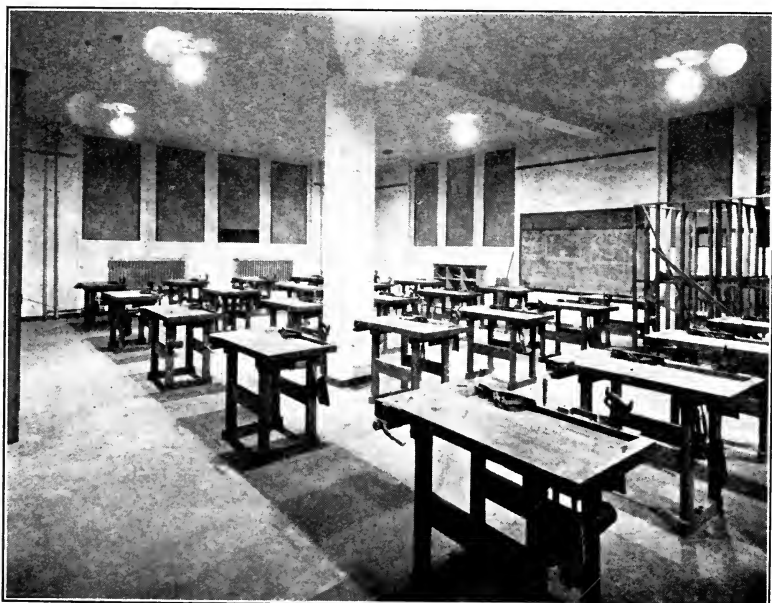

Fig. 4.—Good arrangement of general illumination by direct lighting units in wood-working shop.



Fig. 5.—Indirect lighting of chemical laboratory.

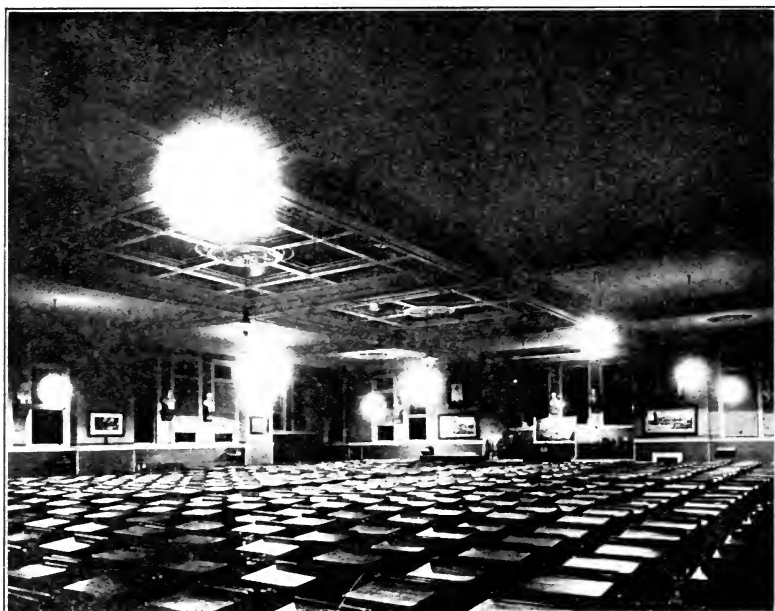

Fig. 6.—Typical poor lighting in a highschool assembly room.

(Facing Figs. 3 and 4.)

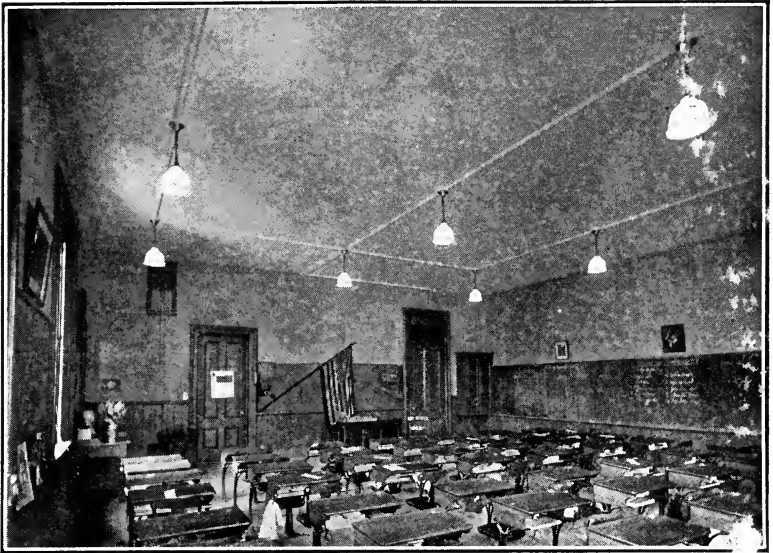

Fig. 7.—Good direct lighting installed in an old schoolroom.



Fig. 8.—Classroom lighting with a few indirect units.

The usual low-hanging height of units, as well as the too often total absence of reflectors and shades, produces the worst possible lighting conditions for a room which is constantly used by a large number of students as a place of study. Nevertheless, this was found to be the case in a large assembly room of a western high school and can be duplicated almost anywhere. (Fig. 6.) (See also Luckiesh's paper "Safeguarding the Eyesight of School Children, Fig. 16.)

Sometimes an attempt is made to improve the very bad conditions produced by old-style gas fixture illumination, by the use of direct prismatic reflectors fastened directly to the old fixtures; but this, while efficient, was, in the case under the writer's observation, improperly installed as far as avoidance of glare was concerned because the old fixtures were, as they almost invariably are, too long and the glare therefore bad. A much more satisfactory as well as cheaper installation could have been made by eliminating many feet of fixture stems and raising the units beyond the range of vision of the students.

Even a newly planned school lighting system may be faulty, as an architect's modern plan, which the writer has in mind, called for one central direct lighting unit per classroom, whereas a vast improvement would be obtained by four units uniformly spaced on the ceiling.

Fig. 7 illustrates an old building which has been equipped with an improved system of direct lighting. As will be noted, the units are hung high, and the light sources are shielded by means of deep diffusing reflectors. The reflectors allow enough light to pass through to light the ceiling to a low intensity, which adds to the cheerful appearance of the room.

In Fig. 8 is shown a classroom in the Boy's High School of New Orleans. This is an installation of indirect lighting, with few units, giving quite uniform illumination and cutting down the objectionable reflection from the varnished surfaces of the desks, glass or blackboards.

A satisfactory and inexpensive indirect system of artificial lighting may also be obtained with numerous units in a large schoolroom, as in the study room of the high school at Lincoln, Nebraska, for instance. There is an exceedingly good uniformity of illumination and an entire absence of glare from the desks and seats in spite of the fact that it is usually not easy to eliminate the undesirable high brightnesses in a large room.

A schoolroom illuminated by means of a satisfactory and inexpen-

sive semi-direct system of artificial lighting is shown in Fig. 9, where inverted opal glass reflectors of sufficient density are employed to reduce the surface brightness of the lighting units themselves to a comfortably low value.

In the lighting of the auditorium of the J. W. Scott High School, at Toledo, Ohio, use is made of diffusing globes hung high on the ceiling. The high mounting height would tend to give good distribution with reduced glare in the eyes of the audience.

The study room of Lincoln (Neb.) High School, Fig. 10, is illuminated by a type of indirect system using numerous units. No bright sources of light are visible as one faces the full length of room. In other words, there is no glare from unconcealed light sources. Compare this with Fig. 6.

The Temple Speech Room of Rugby School, Rugby, England, is illuminated entirely by indirect lighting. The installation is especially interesting because of the use of standard American fixtures installed in England, such installation being made on account of the higher efficiency of the American product.

In Fig. 11 is shown the newly equipped drafting room of the Mass. Institute of Technology, where use is made of inverted translucent reflectors. The picture was taken by daylight to show the simplicity of detail of the units.

It may be of at least passing interest to note the illumination of some of the special departments in a school.

The cafeteria in the Lincoln (Nebr.) High School (Fig. 12) is lighted by the luminous bowl indirect system, the bowls being of a low intrinsic brilliancy, which is particularly desirable in this installation, as the tables used have highly glazed tops, so that any spot of high brilliancy on or near the ceiling would cause annoyance by specular reflection from the surface of the tables.

The Harrison Park Gymnasium, Chicago, is illuminated by a direct lighting system, the light sources being screened from view by deep mirrored glass reflectors with opaque green enamel backing, placed high out of the range of vision.

In the Northwestern University Gymnasium use is made of a combination lighting system. The main illumination is entirely taken care of by direct lighting units, the lamp being set in a deep mirrored glass reflector with opaque green enamel backing, so as not to be visible under ordinary conditions. Each unit is also furnished with two small reflectors furnished with 25 watt lamps, which throw the light upward, illuminating the ceiling. Complete uniformity of illumination and absence of glare characterize this installation.

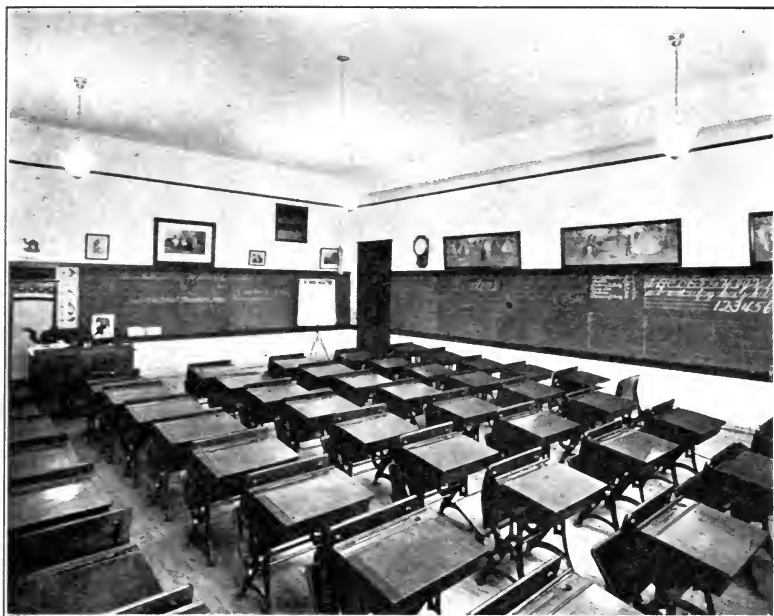

Fig. 9.—Simple semi-indirect lighting installation in schoolroom.

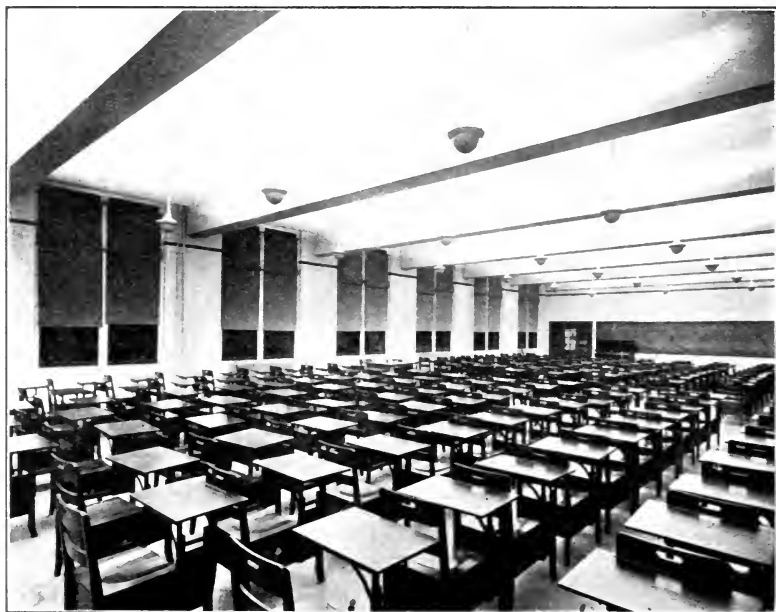

Fig. 10.—Type of indirect system of lighting used in study room.

(Facing page 322.)



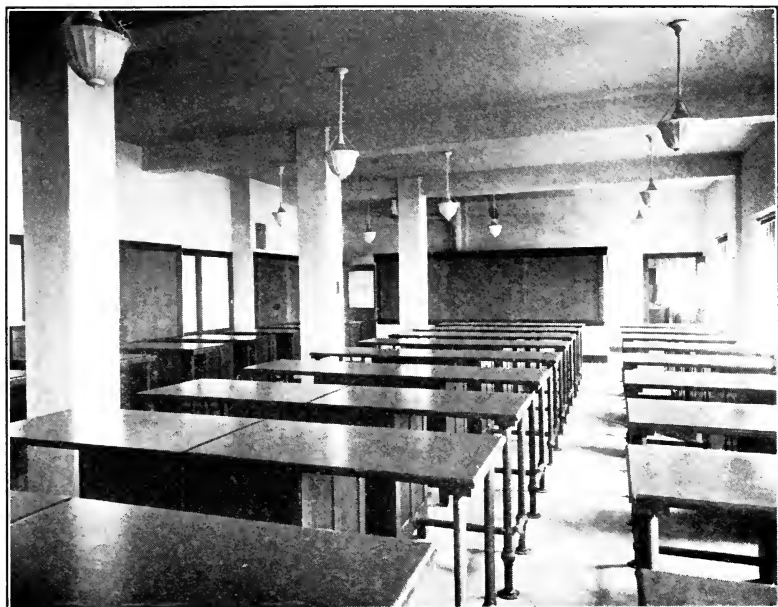

Fig. 11.—Simple semi-indirect lighting installation in a college drafting room.



Fig. 12.—Luminous bowl, indirect illumination in school cafeteria.

The Armory of the University of Illinois presents an example of good lighting of such an area. Use is made of units of the direct lighting type, suspended from the steel trusses supporting the roof, equipped with deep mirrored glass reflectors with opaque green enamel backing, so as to screen the lamps from the eye except at an angle from which the reflector would not ordinarily be viewed, with a resulting satisfactory clearness and uniformity of illumination of the floor. Indirect lighting in buildings of this nature is entirely infeasible due to the type of roof and the structural framework beneath, although some upward light is secured from the arrangement of units and the construction thereof.

## PART II. LIBRARY ILLUMINATION

The actual lighting of a library reading room, as far as the production of the required intensity is concerned, can, of course, be accomplished by any one of the three systems of illumination already spoken of. Since the character of the work performed in a library, namely, reading and studying, is the same as that performed in schools, the arguments set forth above apply in the case of libraries, with the exceptions already noted, with respect to the psychological and æsthetic aspects. If localized direct lighting is used at all, in the library, care should be used to avoid the production of conditions of glare and specular reflection, such as are often obtained by direct lighting on newspaper racks or reading desks, often used in libraries.

If localized lighting is used on the general reading tables, which is sometimes quite a tempting type of installation from the standpoint of economy of operation, certain general principles must be observed, so that the light will be as diffuse as is possible from a direct lighting equipment and the source of light entirely concealed from view and the intensity of the illumination from this source only moderate. Sometimes a combination of a moderate amount of well-engineered localized illumination can be made with the general diffused illumination of an indirect system, as shown in Fig. 13, but it contains, as usually installed, too large a component of direct light to be comfortable.

In this reading room it was desired to continue to use the table lamps which had been originally installed, so that a slightly lower intensity of general illumination would be adequate. Hence, the reflectors of the table units were replaced by spun metal casings, lowered on chain supports to the proper screening height above the table, and a proper deep type of aluminized steel reflector was so

installed as to completely hide the lamp from view. The effect with the lamps in service, is shown in the accompanying illustration, from which it is seen that there is no glare from the direct lighting units.

Where it is at all possible in reading rooms, the position of the reader should be permanently determined and so arranged if direct lighting is used, that the illumination will fall on the book from the rear and one side, and not on his face, or on the book so as to reflect directly into his eyes. In the above illustration the reader could sit and read comfortably with his side to the table but practically no one will do this, unless the chairs are permanently fastened in such a position.

In this reference room of the above library, three central units, together with the marginal units in the gallery, supply indirect illumination as well as the lighting for the gallery book stacks.

The fixtures in this installation are intended to harmonize with the architectural features. Of course, a simpler installation can be and is made in a less pretentious reading room in the same library, Fig. 14, with due regard to the utilitarianism and harmony of design. In this room the illumination is augmented by certain sky-lighted portions, with both natural and artificial light. The ceiling windows are small, however. This view shows the manner in which the book stacks on the upper mezzanine are illuminated by the same opaque indirect lighting units as are used for general illumination, and the manner of lighting the book stacks on the lower mezzanine by indirect units hung directly under the upper mezzanine floor, which, while made of marble, has been painted matte white to produce the proper reflecting surfaces.

In this view also is seen, to the right and to the left of the picture, an adaption of the indirect bracket unit illuminating passageways into the room. The steel half bowls are made for utilitarian purposes primarily, and are part of the steel book stacks, special bracket type mirrored glass reflectors being used. At the present time, newspaper racks have been installed along the sides of the passageway under the indirect brackets. Note the entire absence of desk lamps.

In another portion of the same library book stacks are illuminated from indirect units, consisting of mirrored glass reflectors with green opaque enameled backing placed on top of the book stacks and throwing the light directly on the ceiling above, no fixtures of any kind being installed. (See Fig. 15.)

Fig. 16 shows a newspaper reading room with newspaper racks as well as tables for magazine use, illuminated by a simple indirect system.

Next to the school room, perhaps, conservation of children's eyesight can be best accomplished in the Children's Rooms of the public libraries, and such a room in the Milwaukee Public Library has been indirectly illuminated, in which library the last four examples also exist.

Improvements have recently been made in the illumination of the Congressional Library at Washington. Fig. 17 represents the illumination of some of the book stacks in this library by means of "scoopette" direct mirrored glass reflectors. In this library, the room in which the paper racks are located has also been recently illuminated by the indirect system.

An example of semi-indirect illumination exists in the Toronto public library, where the art collection is illuminated by means of medium density opal bowls.

The large reading room of the John Hay Memorial Library at Providence, R. I., Fig. 18, is lighted entirely by the opaque bowl indirect system, the fixtures being unique in their artistic design and in the fact that a lower section, or sub-structure, has been worked into the design so as to contain light sources to illuminate the outside of the main bowl directly above.

One of the important departments of the public library is the catalogue room, and the facility of properly illuminating the card files is of great value. In the Milwaukee public library the catalogue card indexes are illuminated by an indirect system installed on a very elaborate and deeply cut ceiling, and the diffuse illumination from this system gives a most satisfactory vertical component for use on the cards in the files.

One of the important and ever-growing activities of the public library in large cities is the establishment of branches in the outer portions of the city, where people can be reached by the library if the down town library cannot, or will not, be reached by the people. An example of the illumination of a branch of this character is illustrated in Fig. 19, showing the Austin Branch Library in Chicago, lighted by a large number of indirect fixtures, producing maximum diffusion and uniformity of illumination.

Not all branches of a library can be as well equipped as this, however, for the primary object of such branches is to reach a certain locality and class of people, and it is often more utilitarian and

successful to establish more branches of less pretensions in vacated store buildings or other suitable quarters. An example of the latter sort of branch library may be found in Milwaukee's East Side Branch, located in a store building, with portable book stacks and unpretentious, though properly equipped illumination system, consisting of three steel bowl type of indirect units, spaced down the center of the room.

### PART III. AUDITORIUM ILLUMINATION

In taking up the description of the third division of this subject, namely, auditoriums, it is thought best to divide it into sections, such as churches, lodges, theatres, concert and lecture halls. From an engineering standpoint, many more large interiors for public gatherings might be included, but a narrower scope has been arbitrarily selected as sufficiently illustrative.

#### CHURCHES

The present tendency toward liberality in religion seems to be conducive to liberality in illumination, and well-lighted churches to-day are so ordinary an institution as to make it difficult to restrict the number of illustrations exemplifying this section.

Historically, Fig. 20 represents one of the first attempts to light the auditorium of a large church by practically a single indirect fixture, and shows the Eighth Church of Christ, Scientist, of Chicago, in which, except for the alcoves, the entire auditorium is so illuminated.

Another historical indirect installation is the North Chicago Hebrew Congregational Temple, where a combination of indirect illumination from suspended fixtures and from reflectors concealed in coves is utilized. In the coves are reflectors, lighting the arched central portion of the ceiling, while suspended indirect units are hung from the flat ceilings at the sides.

Fig. 21 shows another early indirect church installation, the fixture design of which should be contrasted with some of these following.

The church as a structure lends itself, perhaps, more readily to architectural development than any other of the edifices with which we are dealing, and for that reason considerably more attention should be paid to the harmonious design of the lighting equipment installed than to that used for other purposes. In some of the following figures, particular attention is directed to the efforts made to select and design fixtures which will produce harmonious results.



Fig. 13.—Indirect lighting in library reference room with specially designed direct table lamps.



Fig. 14.—Reading room and book stacks illuminated entirely by indirect-lighting units.

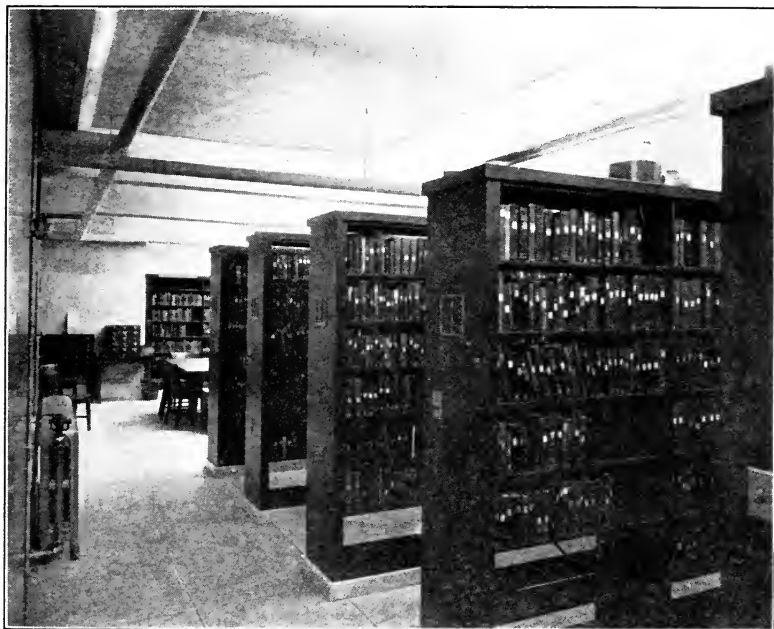

Fig. 15.—Indirect lighting of book stacks without the use of fixtures.



Fig. 16.—Indirect illumination in newspaper and magazine room of a public library.



Fig. 17.—Direct lighting of library book stacks.



Fig. 18.—Library reading room lighted by the indirect system.

(Facing Figs. 15 and 16.)





Fig. 19.—Indirect illumination in a branch library in a large city.

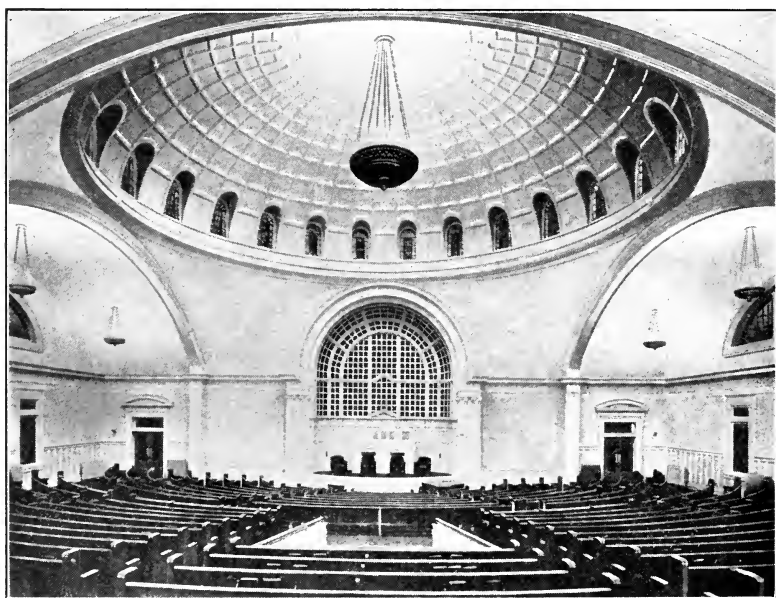

Fig. 20.—Church illuminated principally by means of large central lighting unit.



Fig. 21.—Early indirect church lighting installation.

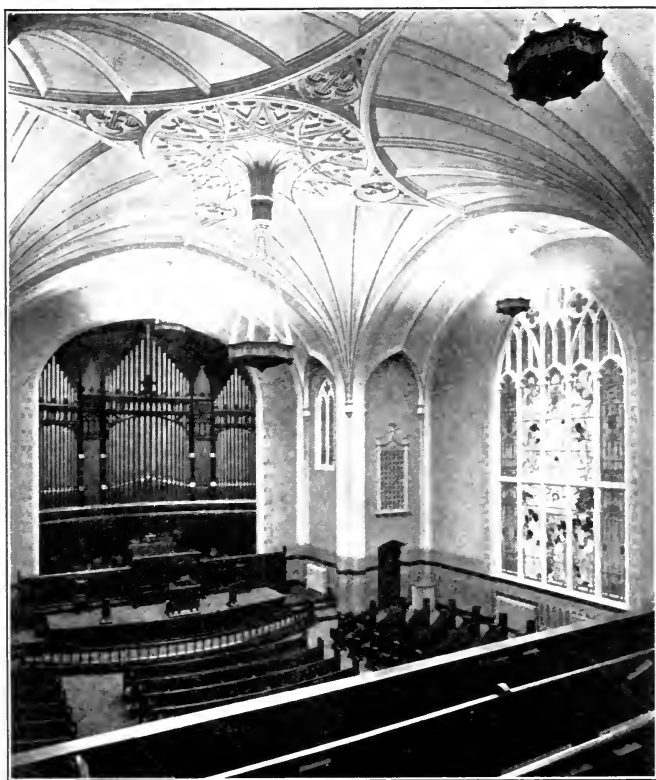

Fig. 22.—Opaque indirect church fixture designed to harmonize with central ceiling ornament.

(Facing Figs. 19 and 20.)

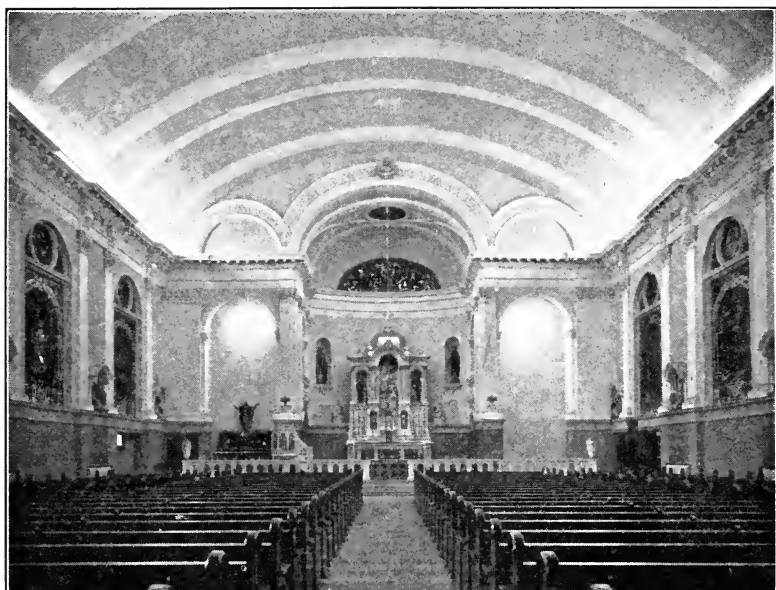

Fig. 27.—Cove indirect illumination in church.

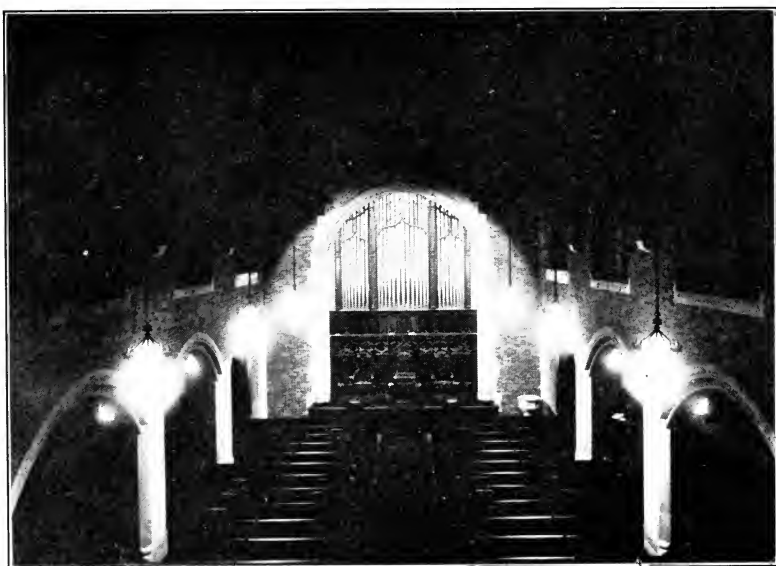

Fig. 28.—Installation of direct lighting to harmonize with Gothic architecture.

Fig. 22 shows an indirect installation in the Everhardt Memorial Church, Mishawaka, Ind., where the main fixture is hung from a central ceiling ornament and with some regard for the harmony between ornament and fixture; this installation differing radically from the Christian Science Church installation, where the fixture is suspended in the center of a large dome, as well as from that represented in Fig. 21.

Fig. 23 shows a church auditorium (Timothy Eaton Memorial Church of Toronto, Canada) illuminated by specially designed luminous bowl indirect fixtures, the translucent portions of the bowl being illuminated by a small frosted lamp, the light for this purpose seeping through tan silk panels in the sides and bottom of the bowl.

An example of the use of a semi-indirect installation in a religious auditorium is shown in Fig. 24, where medium density opal bowls are suspended from the ceiling in two rows down the auditorium. As stated earlier, an installation of this character with bowls of sufficiently moderate brightness and hung sufficiently high, may be made successful.

In certain cases, the architect may feel that a large fixture, suspended in the center of a dome, due to the eccentricity of view from almost every point in the auditorium, is æsthetically wrong for his structure, and yet a diffused type of illumination may be desirable. A solution of such a problem is illustrated in Fig. 25 where a special diffusing glass ceiling window is constructed in such a manner as to give practically the same diffusion to the light passing through from the lamps above as with an indirect system, and this view of the Second Church of Christ, Scientist, in Milwaukee, illustrates how the architect and engineers obtained an artistic luminous "sky-lighted" dome with satisfactory illumination results. By the selection of the glass and placing of lamps, almost perfect diffusion combined with high efficiency was obtained.

Fig. 26 shows the arrangement of the lamps above the ceiling window and is illustrative of the use of the bare lamps in a diffusely reflecting enclosure, which in this case, is the attic structure of the church. By painting the attic the proper white, this space is used as a huge diffusing reflector impinging the light on the window in a very diffused condition, which, with the high diffusive characteristics and low absorption of the selected glass, is so distributed as to produce practically perfect diffusion in the auditorium without the presence of the light sources being visible from below, thus producing

very closely the same effect as would be obtained from the illumination of the ceiling of a dome beneath by an indirect fixture, but avoiding the presence of the fixture.

"Sky-lighting" of this character is often done by means of the lamps above the glass structure being placed in mirrored glass or steel-enameled reflectors, which throw more or less concentrated light upon the glass. This may cause more difficulty in securing diffusion of the illumination beneath, and may also make the light sources more visible, especially if placed too close to the glass.

Indirect illumination can also be obtained from lighting equipment and reflectors placed in coves at the spring of the arched ceilings, as illustrated in Fig. 27, representing St. Cyril's Roman Catholic Church, Chicago, where mirrored glass reflectors are thus installed.

An example of the use of the combination of direct and cove lighting exists in the illumination of the St. Helena Cathedral, Helena, Mont. Here are used "beehive" reflectors in the main ceiling arches, "hood" reflectors in the upper column capitals, and "mid-get" reflectors (all mirrored glass) in the lower column capitals.

As intimated earlier in the discussion, for architectural or artistic reasons, the structure or the architect may require that the upper portions of the auditorium remain subdued in tone, and direct lighting fixtures may therefore have to be designed which will at once comply with the æsthetic requirements and at the same time minimize the glare which would be bound to be present, especially from the galleries, if not thoroughly provided against in such an installation. Fig. 28 shows the Plymouth Church in Milwaukee, where the use of thoroughly diffusing selected glass in a lantern type of fixture designed by the architect to harmonize with the English Gothic architecture seems to suit the conditions by the use of a direct lighting system. In these lanterns, a downward directing prismatic reflector is used, and the lantern is made luminous by an additional small lamp.

Another installation of like character is that of the First M. E. Church, Evanston, Ill., with the addition of side-wall lanterns. In the units in this case, three mirrored glass reflectors are used in combination with three prismatic glass reflectors, the combination producing the desired distribution as well as the moderate luminosity of the sides of the unit.

If for any reason, architectural or otherwise, it is desirable to illuminate a church from floor standards, it can be done by the indirect system, providing the ceilings are suitable, by the use of the

type of floor standard shown in Fig. 29, which indicates such an installation in the entrance of the First Church of Oak Park, Ill.

### LODGE ROOMS

In the lodge room, a semi-religious function must be considered, and this division of the subject therefore is closely allied with the illumination of the church.

As an example of the lodge room recently lighted by the indirect system, there is shown in Fig. 30 the Masonic Hall in the Auditorium Hotel in Chicago. This hall is lighted by the opaque indirect units on the ceiling, and also by lamps in the cove under the pictures and back of the windows. Due to the ritual work done in the hall, the lamps are so arranged that the light intensity may be lowered to a very low degree, or a certain portion of the lamps may be cut out entirely, as, for instance, the ceiling lamps, leaving a dim illumination from only the cove lamps.

Fig. 31 shows the Boulevard Masonic Hall of Chicago which has been lighted entirely by means of side-wall indirect brackets, which are in the form of decorative boxes with vines, etc., giving the effect of growing plants. Each box contains a number of mirrored glass reflectors so designed as to throw the maximum amount of light onto the ceiling, with a very small amount of so-called "wall-splash." This lighting has been so arranged that it is possible to obtain three different intensities besides a very dim lighting for ritual work.

Fig. 32 shows the lodge room of the Knights of Columbus, Milwaukee, Wisconsin. The lighting of this room was accomplished entirely by luminous bowl indirect lighting units, using bowls with glass panels, enough light being permitted to pass through the glass to give them sufficient illumination not to appear dark. For ritual work only the two center units are used, these being so arranged as to furnish any colored light desired for such services. Each unit contains red, blue, green and white colored light sources, each color being controlled by a separate dimmer. By means of this color mixing facility, it is possible to form any combination desired, and to allow for the changing of the mixture from shade to shade, gradually or quickly, as desirable.

Fig. 33, as an example of semi-indirectly illuminated lodge rooms, shows the lodge rooms of No. 1 Masonic Temple, Washington, D. C. The photograph gives no accurate conception of the actual illumination, since it was made by daylight and not by the use of the lighting units themselves.

## THEATRES

Before inspecting some of the modernly illuminated theatre auditoriums, it may be of interest, again, to take a backward step of a few hundred years, and review historically the development of this problem and its solutions.

Of historical interest is the English theatre of 300 years ago, where the acting was done in the open air and the theatre was a U-shaped structure with the audience on the two sides in two or more storied amphitheatre resembling primitive "bleachers." In this type most of the acting took place under the open sky where the actors were surrounded on two sides by the audience. These performances all took place in broad daylight, and hence required no artificial illumination.

In the drama of the days of Shakespeare's boyhood, the actors made use of little scenery and not much costuming or make-up, the performance being given in the courtyard of a village inn as afternoon matinees. The courtyards with their galleries formed automatically a theatre somewhat similar to that just described, performances again being given by daylight.

Coming now to this country, and a later date, the old John Street Theatre, New York, which was opened in 1767, is of interest. The auditorium and stage were of most primitive type and the very earliest type of lighting known for an auditorium of this character was used. The view of the interior of this theatre, which is on record, indicates that there were two four-arm chandeliers near the stage, each arm apparently carrying a kerosene lamp or candle, the whole design being most primitive and simple. Nevertheless, considerable publicity was given at that time to the successful accomplishment of the illumination of this theatre.

The old theatres of Europe present a few interesting features with respect to the illumination and their general architectural design. Fig. 34 is typical of the old type of auditorium lighting, which is typified by a large elaborate central fixture supporting bare incandescent lamps in conjunction with ceiling studded effects and a tremendous number of bracket lamps lavishly distributed over all balconies and in the direct range of vision.

Turning to our country, probably the best known and surely the most deserving of fame, is the Metropolitan Opera House in New York (built in 1883). The lighting of this opera house carries out the same general scheme as those in Europe, namely, the large

center fixture with its semi-protected lamps and its rows of lamps around the fronts of the balconies and boxes—all of which gives a very hurtful illumination for spectators, except for those seated in the body of the house and far enough forward to probably escape the glare of the side lamps.

Later on, a movement, perhaps unwittingly made in the right direction, placed the light sources directly on the ceiling and beams in studded effects, which, if the architecture happened to be appropriate, took the sources out of the range of vision; but the more or less ignorant use of this type of illumination produced in many cases even worse effects than the central fixture type.

The Auditorium Theatre in Chicago, shown in Fig. 35, is typical of the bad examples of this type. This needs very little description. The bare lamps in the arches indicate for themselves the effect on the eyes of the spectators.

Fig. 36 shows the Auditorium in Milwaukee taken by artificial illumination. The lighting underneath the top balcony is accomplished by means of 10-in. sand-blasted globes, while the main portion of the hall is lighted by rows of hundreds of bare lamps, around the center ceiling window and sand-blasted shades between the various arches. The effect of glare on the audience is very bad indeed, as it is almost impossible for a person to sit in this long hall without having glaring lamps in his direct vision, the worst effect being experienced by those in the first and second balconies, and in the boxes, in which cases the eye receives the full glare of the center lamps. Recently some changes have been made by the installation of smaller and denser globes under the balconies, which eliminates the units from vision. It is also contemplated to modernize the entire lighting scheme in this auditorium in the near future.

One of the earliest scientific attempts to eliminate light sources from the view of the audience was in the University of Wisconsin lecture room, where the lamps are placed in reflecting troughs on the stage side of the beams, with very satisfactory results as to glare from the viewpoint of the audience, but, of course, with the maximum of bad effect to those on the stage facing the audience.

In another theatre of national fame, the Hippodrome of New York, the lighting is accomplished by lamps carried along various construction members of the ceiling and also over the proscenium arch. Here again the glare is bad, but a large portion of the audience is protected on account of the immensity of the auditorium.

Sometimes in the theatrical audience there seems to be consider-



able desire and possibly some excuse for ignoring almost entirely the engineering and economic side of this question and producing artistic results primarily, if not entirely. As an appropriate example of a theatre where the fixtures have been made highly artistic with comparatively little regard for other factors in the problem, Fig. 37 is presented, showing the Little Theatre of New York, with its beautifully artistic interior.

A somewhat similar, foreign example of the use of highly artistic fixtures is the Audience Room of the Royal Palace, Madrid. Here, however, the most interesting feature is the use of the Moore vapor tube type of system on the ceiling.

In later years greater efforts have been made to conceal the light sources from the view of the audience and to produce soft, though sufficient, illumination effects, at least, in certain types of theatrical auditoriums. This latter movement has been toward the indirect system of illumination, and the following are some examples of this type.

One of the first, if not the first, theatre to be totally illuminated by the indirect system was the Pabst Theatre of Milwaukee. This theatre was originally lighted by a large central fixture, bare studded lamps around the domed ceiling, bare lamps along the fronts of the balconies, and also, bare lamps around the proscenium arch. Due to the annoyance on account of the large amount of glare from the bare lamps, this installation was finally superseded by a complete indirect lighting system. Use was made of a large central unit hanging in the center of the dome augmented, underneath the various balconies, by smaller units, mainly for artistic influence. The theatre walls being dark in color and the furnishings of the same color, it was necessary, in order to make indirect lighting a success, to provide a means of redirecting the light from the ceiling down on the working plane. This was accomplished by means of false ceiling, or reflecting discs, painted a very light ivory, which were placed above the various units. At the same time the dome was redecorated in a lighter shade. Fig. 38 shows the central fixture and its reflecting disc.

Fig. 39 shows an auditorium lighted by means of opaque indirect fixtures, typical of hundreds similar now in existence, where there are no bare lamps directly in the range of vision of the audience.

In the Germania Theatre in Chicago, an unconventional system of indirect lighting is used by placing the lighting units in specially designed boxes on the side-walls (Fig. 40), carrying out certain



Fig. 29.—Indirect illumination of church lobby by means of floor standards.

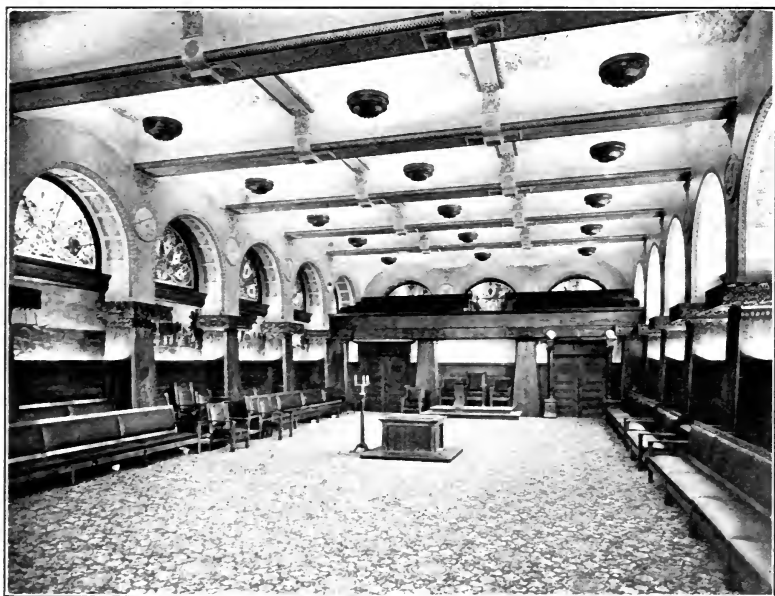

Fig. 30.—Lodge room lighted by opaque indirect units and auxiliary special cove units.

*(Facing page 332.)*

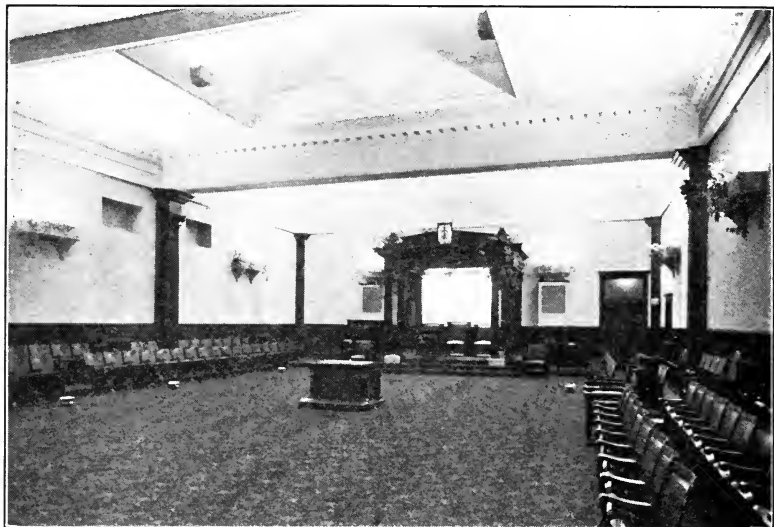

Fig. 31.—Lodge room illuminated by special design of indirect wall brackets.

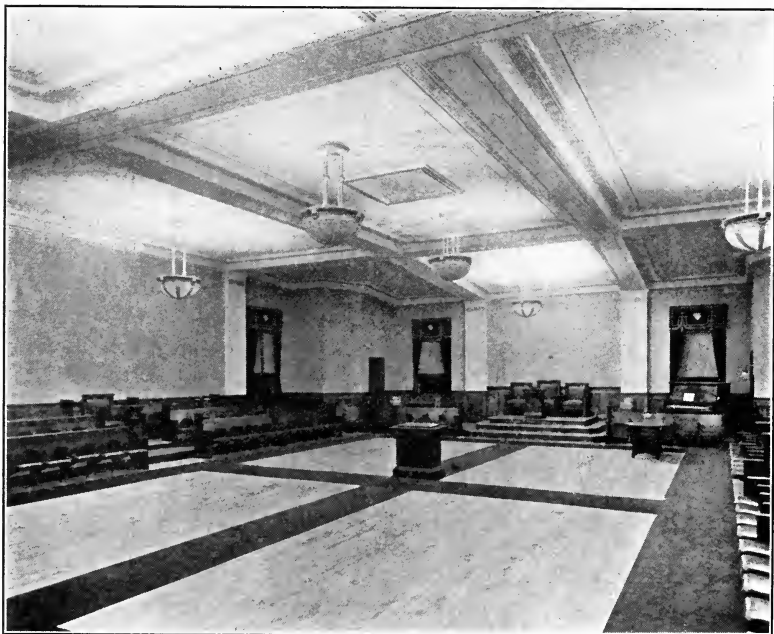

Fig. 32.—Lodge room illuminated by luminous-bowl indirect units.

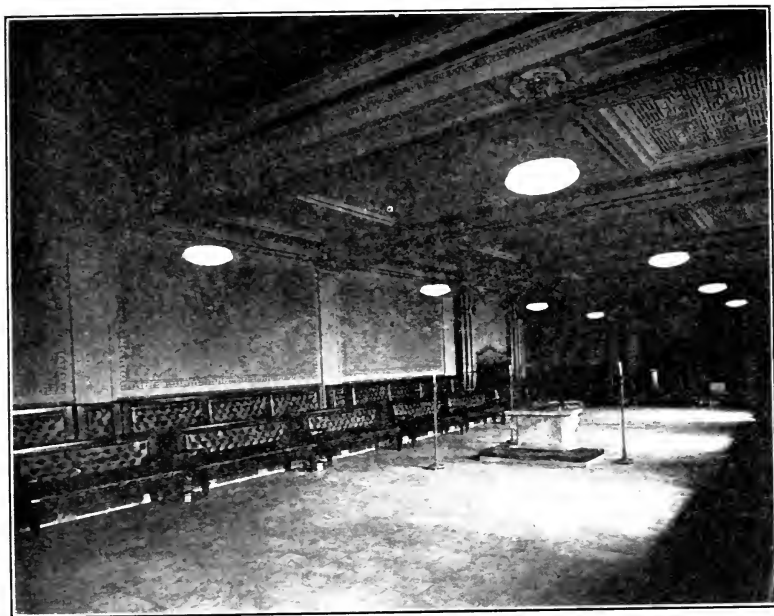

Fig. 33.—Lodge room with semi-indirect lighting units.



Fig. 34.—Early foreign type of direct lighting of theatres.

(Facing Figs. 31 and 32.)

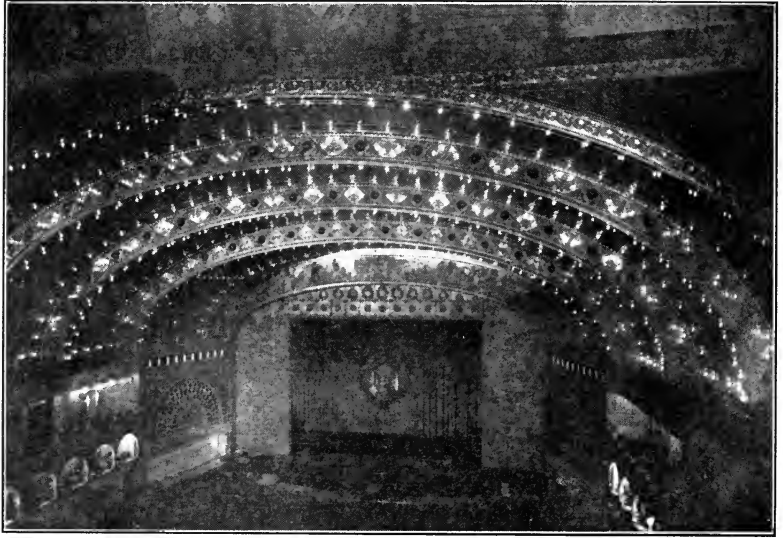

Fig. 35.—Typical bare lamp studded effect.



Fig. 36 —Glaring lamps in auditorium lighting.

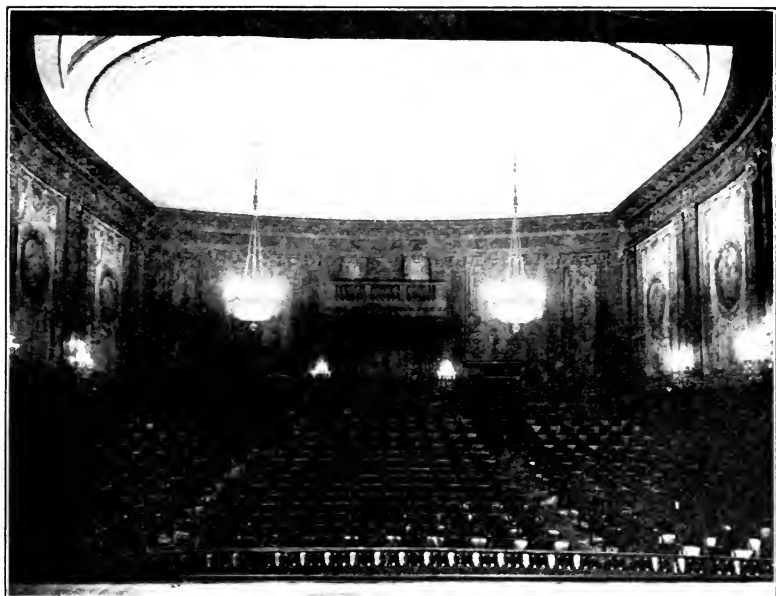

FIG. 37.—Artistic arrangement of theatre lighting installation.

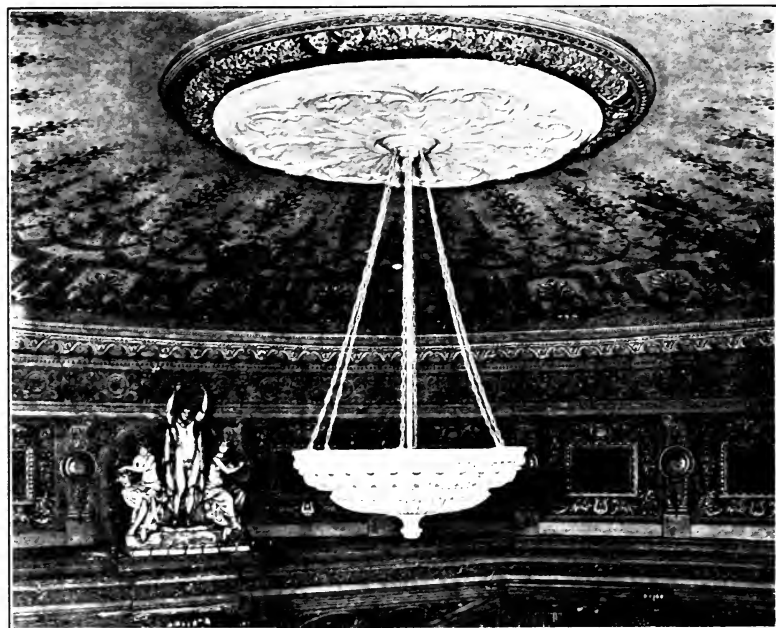

FIG. 38.—Early indirect lighting installation in theatre.

(Facing Figs. 35 and 36.)

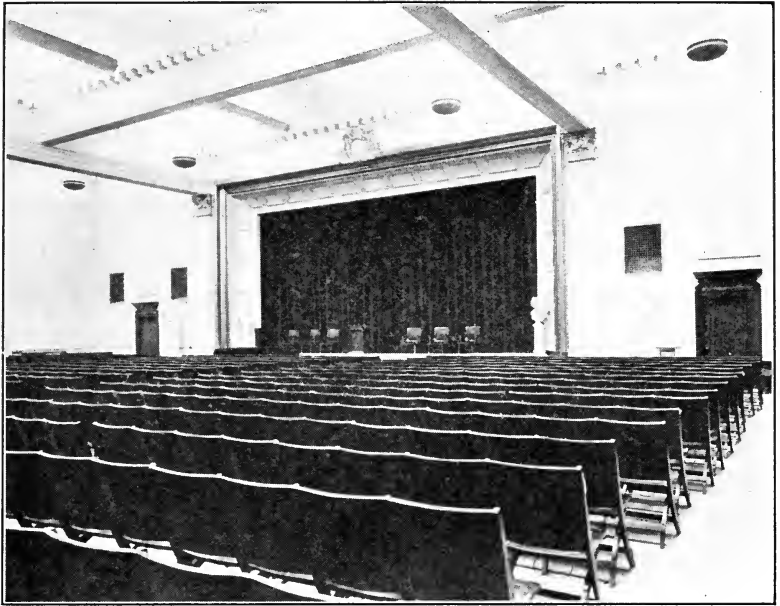

Fig. 39.—Auditorium illumination by opaque indirect units.

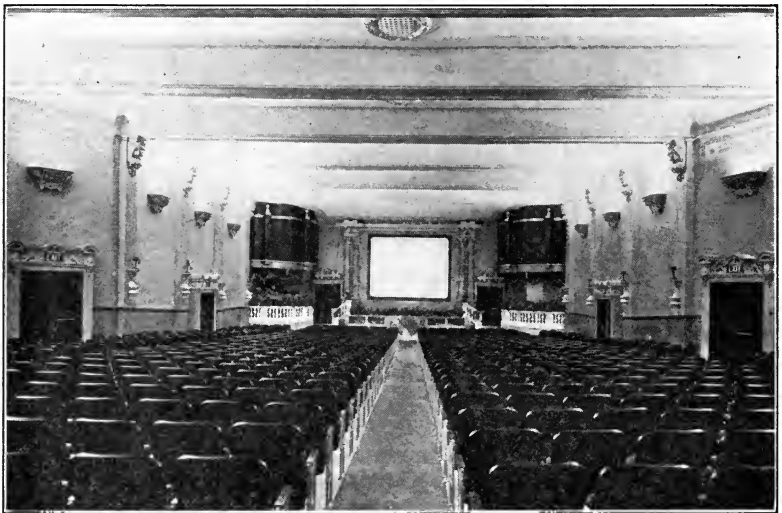

Fig. 40.—Theatre illuminated from indirect wall-bracket units.

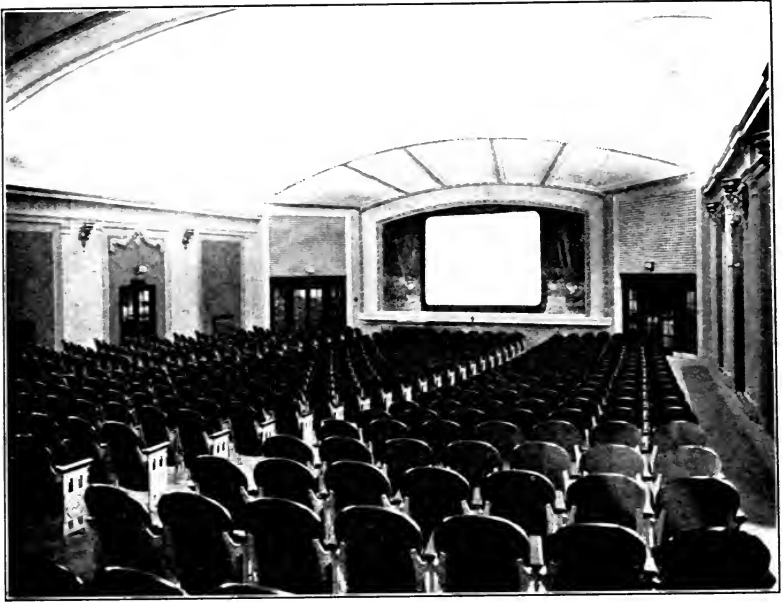

Fig. 41.—Theatre illuminated by cove-type of indirect installation.

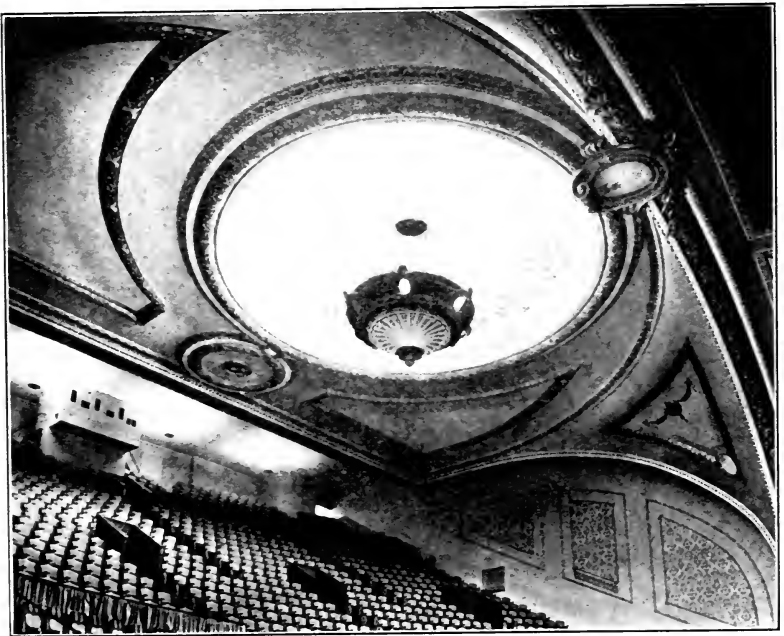

Fig. 42.—Theatre illuminated by luminous-bowl type of indirect unit.

(Facing Figs. 39 and 40.)



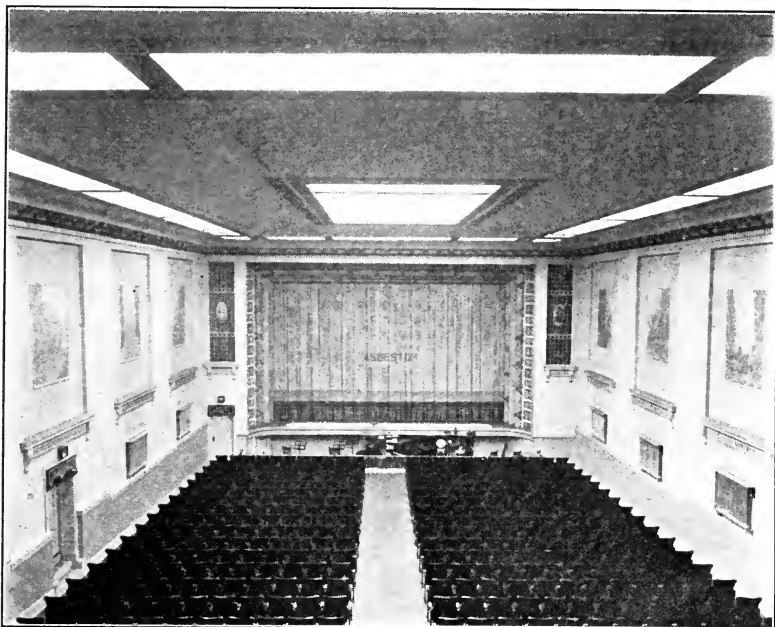

Fig. 43.—Theatre illuminated by artificial "skylight."

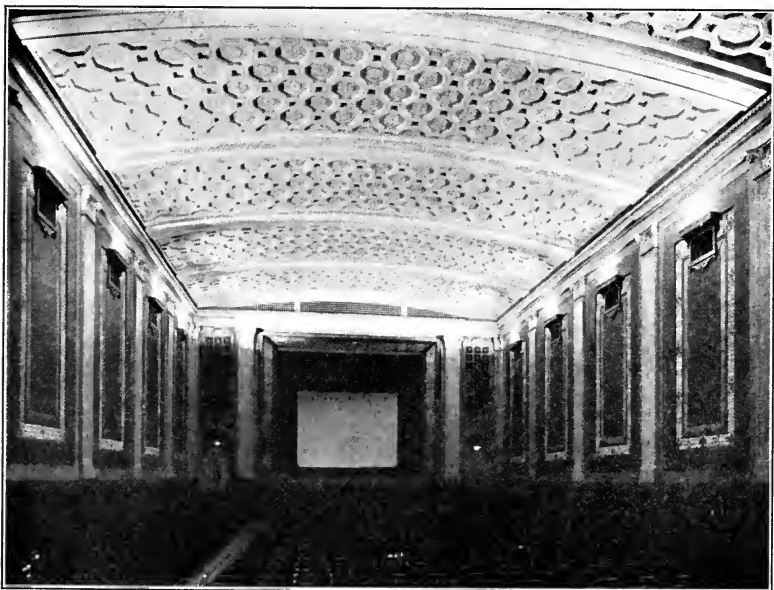

Fig. 44.—Theatre illuminated without fixtures; units situated on top of ventilating registers.

artistic effects as well as eliminating the use of fixtures from the ceiling.

Another variation of the indirect system is shown in Fig. 41 of the Wilmette Theatre, which is an example of cove indirect lighting from trough reflectors placed in the cornices of the room.

Perhaps the latest example of the indirect illumination of a theatre is the Palace Theatre in Milwaukee, which has just been opened, where the main auditorium, Fig. 42, is illuminated from a central unit which has the luminous bowl characteristics through decorative panels in the fixture.

The Rialto Theatre in New York is perhaps the latest and most elaborate example of indirect lighting effects in a theatre. Besides the idea of lighting by means of indirect illumination, many colored schemes, decorative and flooding, are utilized very effectively, and it is to be regretted that an adequate illustration of these effects cannot be presented.

Auditoriums of photoplay theatres present a condition differing somewhat from that in the auditoriums of the legitimate theatre, in that sufficient light has to be furnished to permit the audience to find their way about, and yet at the same time, it must be of a low enough intensity so as not to interfere with the picture being shown upon the screen. Again, the intensities of different parts of the house may be materially different, since the surface most vitally important is the screen at the front of the theatre, and it is usually possible to raise the illumination in the rear or entrance of the theatre, away from the screen, to a much higher intensity of illumination than toward the screen. In this way, a person entering is not at first subjected to as low an intensity of illumination as he is after having passed down toward the front of the theatre, and the few moments' lapse between the time of entering and the time of reaching an area of the lower illumination gives the eye a certain amount of time in which it can accustom itself to the lower illumination. A second requirement of this type of lighting is to have the greatest amount of illumination thrown upon the horizontal plane—namely, the seats and aisles. It is poor practice to throw any amount of light on the side-walls, due to the effect upon the screen, and such light is practically wasted, since it serves no utilitarian purpose. A third point which has to be considered is the absence of all sources of light from the field of vision, such as bracket lamps along the side walls, or lamps on either side of the screen. Such lamps only tend to disturb the eye and cause a diversion which distracts the atten-

tion from the picture on the screen. Several of the illustrations already shown were examples of this type of auditorium.

In Fig. 43 is shown the auditorium of the Delft Theatre, Escanaba, Mich. This auditorium is used for both the legitimate theatre and for photo-play productions. The lighting is effected solely by means of windows in the ceiling, as shown. Above these windows are long boxes, approximately 18 in. in height, painted white inside, which act as diffuse reflectors, throwing the light through the windows into the auditorium. The glass used gives very good diffusion and efficiency. The lamps are arranged on three separate circuits, allowing the use of full intensity, a secondary intensity, or a very low intensity for photoplay work. The last, or lowest intensity, has been so graded by the use of different size lamps as to furnish a very low illumination near the front of the theatre, but a higher illumination toward the rear. This type of lighting directs the greater percentage of the light directly to the seats and aisles.

In the Butterfly photoplay theatre of Milwaukee was made one of the first attempts at indirectly illuminating an entire photoplay theatre. The light here, again, is of two intensities—either a full intensity which is used at the end of the program, or a very low graded intensity, which is on during the presentation of the films. The lighting is accomplished entirely by the opaque indirect units.

In Fig. 44 is shown a third photoplay auditorium; this being the Merrill Theatre of Milwaukee. The lighting system employed here is different from the other two shown, in that there are no fixtures on the ceiling, for the indirect lighting. The light is thrown on the ceiling from recesses in the side-walls. Use is made of mirrored glass reflectors set at such an angle as to give approximately uniform illumination on the ceiling. There are in this installation three different lighting schemes—the first gives a comparatively high intensity of illumination, which is used at the end of the program; the second intensity is a very low, graded intensity, which is used during the presentation of the films; the third intensity is still lower, use being made of a blue light in place of the ordinary light of the vacuum lamps, when blue tinted films are used on the screen for night scenes. The lighting in the rear of the auditorium, under the balcony, is accomplished by ceiling windows of the same general type as those of the Delft Theatre previously shown—such lighting being considered preferable to the effect produced by hanging fixtures, which would give a cluttered appearance under the balcony.

## CONCLUSION

As stated at the outset, this subject is so broad and so much good exemplary work has been done, that one might go on indefinitely describing interesting installations, but a sufficient number, it is believed, have been shown to indicate the progress in this branch of the art of illumination, and to exemplify the different types of installations which have been developed to meet the various conditions surrounding the specific problems.

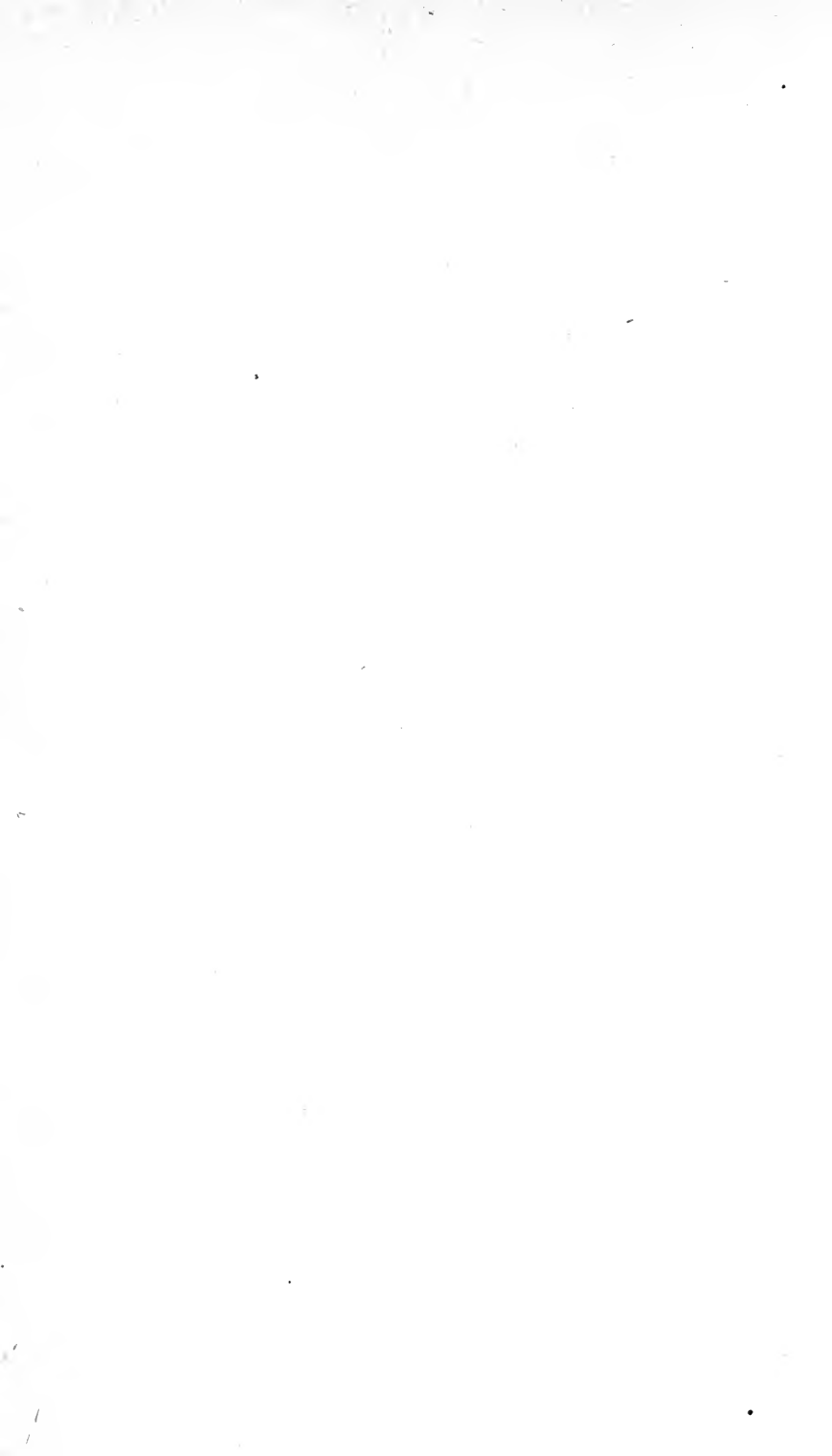

## THE LIGHTING OF FACTORIES, MILLS AND WORKSHOPS

BY C. E. CLEWELL

In May, 1910, Prof. Chas. F. Scott, Sheffield Scientific School of Yale University, in an editorial in the *Electric Journal*, made an analysis of the costs of factory lighting in terms of wages, thus emphasizing a new point of view in the consideration of industrial lighting. In the years following, it has become quite common to evaluate factory lighting costs to an equivalent proportion of the wages of the employees who use the light, as one of the best ways of expressing the advantages of good light in factory work.

### RELATIONS OF ADEQUATE LIGHTING TO FACTORY PRODUCTION

Any factory executive or manager should take an interest in those factors which may influence, for good, the production rate of his plant, provided the matter is presented to him in a convincing manner; and he will be found, in many cases, to accept as a working basis for the value of the best lighting to his plant the return in quantity and quality in production resulting directly or indirectly from the expenditure for a modern system of lighting to replace an old and an inadequate system.

The value of adequate factory lighting may thus be reduced in a simple manner to such items as the *time it saves* the employees in the performance of their regular work, the *improved accuracy* it makes possible in workmanship, the *protection and safeguarding of the eyes* of the workmen, the *beneficial effect of bright and cheerful surroundings* on the temperament of those affected, and the tendency it has to *reduce accident hazard*.

If, therefore, in summarizing the advantages of good factory lighting, in contrast to inferior lighting conditions, the cost of improved light be evaluated to the equivalent time saved the employees in the general run of their work, it will be found that the wages thus saved are usually materially greater than the cost of the lighting, and the net saving to the plant, either through reduced wages for the same output, or in larger and better output for given wages, due to improved lighting, is just as definite and important an asset

to the plant as is a new machine tool which, due to its higher efficiency in contrast to an older machine, is capable of effecting a similar economy.

As a starting point, therefore, it is desirable to assume toward adequate factory lighting an attitude of such a nature as to class it as one of the economies in industrial management; and, rather than to place too much emphasis on the cost of the different available types of lamps or on the various systems of lighting, to concentrate the major part of the attention on the improved quality and quantity of workmanship which may be expected to accompany better lighting. In brief, it is well to think of lighting as an asset to the plant, and, when deciding on the type of lamp to install, to consider which type is best suited to the needs of the factory, rather than to direct all attention, as is so often the case, on those relatively small differences in first cost, which sometimes lead to a selection of the cheapest rather than the best.

As a matter of fact, the past five or ten years have witnessed widespread improvements in many factories where the prevailing former conditions were very poor, and a typical factory manager of to-day, whose sections are equipped with modern lighting, is able to take a certain pride in the improved appearance of the surroundings, and at the same time he has the assurance that the accompanying improved workmanship and sentiment of his employees, represent material returns in excess of any outlay he may have been called upon to make for the improvements in question.

As obvious as these indirect advantages may seem to be, they are not as satisfying, nor are they as useful in the practical advancement of better lighting conditions in the industries, as would be the case were there more definite examples of cash returns available due to improved light, or were there on record actual numerical percentages of increases in output due to the same cause. The need for such definite information is made evident in a statement by Dean A. J. Rowland, in a discussion on the subject of factory lighting several years ago, part of which follows:<sup>1</sup>

“There is one very important detail of industrial lighting which seems to have been given but little attention by anyone; that is, the accumulation of data which will give the answer to this question: Is it or is it not worth while to light rooms and machinery correctly and well?

“Such questions are as important as any which can be considered in connection with industrial lighting. The kind of lamps used, their

<sup>1</sup> Trans. I. E. S., vol. VIII, No. 6, pp. 286 and 287.

arrangement, the kind of shades put on them, are insignificant matters compared with the money value of good light to the industries. This will have to be determined somehow if industrial lighting is to come into its own."

This quotation from Dean Rowland's discussion is merely given as typical of the impression which prevails that such data are badly needed, and while this need is generally recognized, the data desired are very difficult to obtain, and several quotations from a number of authorities must be taken at this time roughly to indicate the available information on this general phase of the problem.<sup>2</sup> It will be noted that some of these quotations refer to advantages of good light and the disadvantages of bad light, based on features other than those of economy. In a general way, however, they bear directly on the important question as to "Why good light is a necessity?"

As an example, the first report of the Departmental Committee on Lighting in Factories and Workshops (London, 1915) contains several comments as follows:<sup>3</sup>

"Complaints of eye strain, headache, etc., attributed to insufficient lighting are common, and while an exhaustive medical inquiry would be necessary to establish the connection between these defects and inadequate lighting, there is a general impression that unsatisfactory lighting is, in various ways, prejudicial to health. It is also recognized that insufficient light adds to the difficulty of the proper supervision of work, and of the maintenance of cleanliness and sanitary conditions generally.

"Witnesses gave specific instances of the effect of improved lighting in increasing the output and improving the quality of work turned out."

Again, in the same report, the following statement appears concerning the diminished output of work due to insufficient light:<sup>4</sup>

"The effect of improved lighting in increasing both the quantity and the quality of the work is generally admitted, and specific instances are quoted in the evidence. In one instance the output was diminished 12 to 20 per cent. during the hours of artificial lighting, and in another the earnings of the workers increased 11.4 per cent. after the installation of a better system of lighting."

A clause from one of the Public Health Bulletins of the United States Health Service<sup>5</sup> presents the case from a somewhat different point of view, as follows:

<sup>2</sup> An experimental investigation is under way at this time to secure definite information concerning the advantages of good factory lighting, the work being planned by the Lighting Committee of the Commonwealth Edison Company of Chicago.

<sup>3</sup> Memorandum of British Report, p. 2.

<sup>4</sup> Main part of British Report, p. xiii.

<sup>5</sup> No. 71, May, 1915, p. 105. J. W. Schereschewsky and D. H. Tuck.



"In view of the fact that a large part of the industrial operations in the women's garment trades involve the close and continuous use of the eyes, the illuminating conditions which prevail in the workshops of the industry become highly important from the standpoint of industrial hygiene. The necessity for adequate and correct illumination on the various working planes becomes the more apparent from the consideration of the data in relation to the vision of garment workers contained in the foregoing portion of this report. These data show that only a little over 25 per cent. of the workers whose visual acuity was tested had normal vision in both eyes."

Turning now to somewhat more tangible wage equivalents, several good examples are found in a discussion on factory lighting by M. H. Flexner and A. O. Dicker,<sup>6</sup> one of which may be summarized as in Table I.

TABLE I

Under the assumption that good factory lighting requires a 100-watt tungsten lamp for each 100 sq. ft. of working area, and that one workman occupies each 100 sq. ft., the following statements may be made:

*Constants:*

Working hours per annum (10 × 300).....	3,000 hours
Lighting hours per annum (3½ × 300).....	1,000 hours
Labor cost per hour.....	35 cents

*Labor cost:*

3,000 hours at 35 cents.....	\$1,050.00
------------------------------	------------

*Lighting cost:*

First cost	{	Lamp (free renewals).....	\$0.00
		Reflector.....	1.00
		Wiring.....	4.00

<i>Initial cost per outlet</i> .....	\$5.00
--------------------------------------	--------

Operation	{	Interest at 6 per cent.....	\$0.30
		Depreciation at 12½ per cent.....	0.63
		Annual cleaning at 3 cents.....	0.36
		Lamp renewals.....	0.00
		100 kw-hr. at 5 cents.....	5.00

<i>Annual operation cost</i> .....	\$6.29
------------------------------------	--------

*Conclusions:*

Cost of light in per cent. of wages.....	0.60
Cost of light per hour.....	\$0.006
Cost of labor per hour.....	0.35
Cost of light per day.....	0.02
Cost of labor per day.....	3.50

These data show that the cost of good lighting is a very small proportion of the value of a man's time; in fact, if good lighting effects a saving of five minutes of a man's time per day, a material gain would be experienced.

<sup>6</sup> Trans. I. E. S., vol. VIII, No. 8, pp. 477 and 478.



Fig. 1.—Tungsten direct lighting with opaque mirrored glass reflectors.



Fig. 2.—Drafting room with a system of semi-indirect tungsten lighting.

(Facing page 340.)



Fig. 3.—System of industrial indirect lighting with tungsten lamps.

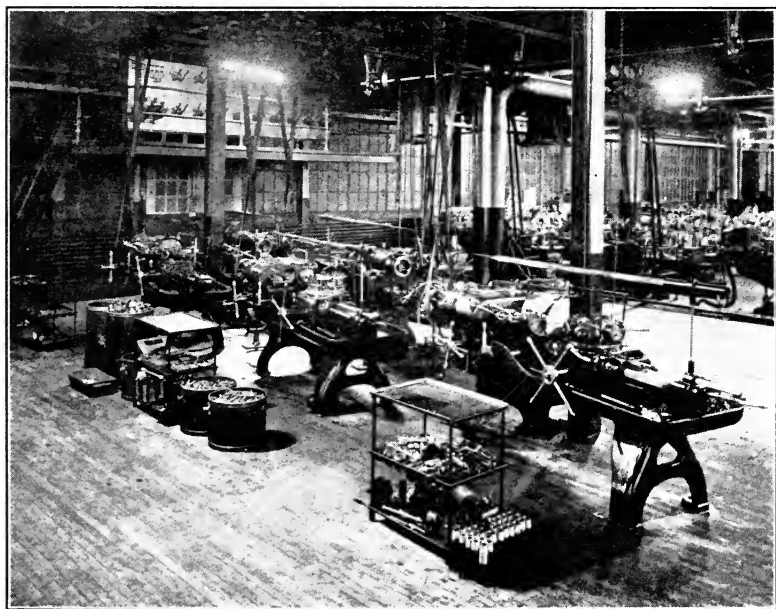

Fig. 4.—Machine shop with a system of mercury vapor lamps.

A similar example worked out in a slightly different manner is given in the recent Code of Factory Lighting of the Illuminating Engineering Society, as follows:<sup>7</sup>

"From the manufacturer's point of view, the cost of the annual operation and maintenance of the illumination of a typical factory bay of 640 sq. ft. area, may be taken at \$50.00 under certain assumptions as to energy cost, cleaning, interest and depreciation. If five workmen are employed in such a bay at an average of say 25 cents per hour, the gross wages of the men in such a bay, plus the cost of superintendence and indirect factory expense, may equal from \$5000 to \$7000 per annum.

"In a case of this kind, therefore, the lighting will cost from 0.7 to 1.0 per cent. of the wages, or the equivalent of less than the wages for from 4 to 6 minutes per day. We may roughly say that a poor lighting system will cost at least one-half this amount (sometimes even more through the use of inefficient types of and a poor arrangement of lamps), or the equivalent of the wages for from 2 to 3 minutes per day. Nearly all factories and mills have at least some artificial light, hence, in general, if good light enables a man to do better or more work to the extent of from 2 to 3 minutes per day, the installation of good lighting will easily pay for the difference between good and bad light, through the time saved for the workmen."

The foregoing discussions and quotations are typical of the viewpoints which have been assumed in recent years toward the field of industrial lighting, on which the following advantages of good light may be based:

1. *Increased production for the same labor cost.*
2. *Greater accuracy in workmanship.*
3. *Reduced accident hazard.*
4. *Avoidance or at least reduction of eye strain.*
5. *Surroundings made more cheerful.*
6. *Work performed with less fatigue.*
7. *Order, neatness and sanitation promoted.*
8. *Superintendence rendered more effective.*

*In other words, factory lighting is important to production; its cost is small in comparison with its advantages; and when its cost is interpreted or reduced into the equivalent wages saved through its adoption, the expenditure for the best lighting is usually a very small item by contrast.*

#### SUMMARY OF FACTORY LIGHTING LEGISLATION

As pointed out in a recent paper<sup>8</sup> by L. B. Marks, legislation on lighting is so meagre and scattered and apparently so little called for

<sup>7</sup> Issued by the I. E. S. in 1915. Quotation from pp. 14 and 15.

<sup>8</sup> Trans. I. E. S., No. 1, 1916.

in this country that no legislative bureau has found it worth while to collate it. Mr. Marks points out that five years ago (1911), based on an extended review of factory legislation under the direction of Prof. John R. Commons,<sup>9</sup> and reported by E. L. Elliot,<sup>10</sup> there were only eleven states that made any mention of the subject of light in their general factory or labor laws, and in not one of these were the provisions sufficiently specific to render them of practical value.

Since that time, factory lighting legislation has received attention in several states, the most prominent cases being Wisconsin, New York and Pennsylvania. Briefly stated, the legislation in both Wisconsin and New York, while a step forward in each case, has been rather indefinite, mainly because in neither case are the requirements specific with regard to the illumination at the point of work.

Following the legislation in these two states, two important new developments have been made in this direction. The one has been the publication in 1915 of a Code<sup>11</sup> for the lighting of factories, mills and other work places by the Illuminating Engineering Society, as a

TABLE II  
(Intensity Values in Foot-candles)

Classification of space	Cjewell <sup>12</sup> (1913)	G. E. Co. <sup>13</sup> (1913)	Wisconsin <sup>14</sup> (1914)	I. E. S. code <sup>15</sup> (1915)	British report <sup>16</sup> (1915)	Pennsylvania <sup>16</sup> (1916)
General lighting of work rooms, irrespective of the actual light required by the work . . . . .	....	0.80	....	....	0.25	
Yards . . . . .	....	....	....	....	0.05	0.05
Stairways, passages, storage, and the like . . . . .	0.50	0.50	....	0.25	0.10	0.25
Foundries . . . . .	....	3.00	1.50	1.25	0.40	1.25
Rough manufacturing . . . . .	3.00	2.00	0.75	1.25	....	1.25
Fine manufacturing . . . . .	5.00	5.00	1.50	3.50	....	3.50

<sup>9</sup> American Legislative Review, vol. I, No. 2, June, 1911.

<sup>10</sup> Trans. I. E. S., 1911, p. 722.

<sup>11</sup> "Code of Lighting, Factories, Mills and other Work Places," issued by the Illuminating Engineering Society, Trans. I. E. S., vol. X, Nov. 20, 1915, pp. 605-641.

<sup>12</sup> "Factory Lighting," N. Y., McGraw-Hill Book Co., 1913.

<sup>13</sup> "Handbook on Incandescent Lamp Illumination," General Electric Co., 1913.

<sup>14</sup> Intensities estimated on basis of specifications of candle-power per sq. ft.

<sup>15</sup> Minimum requirements.

<sup>16</sup> No recommendation is made for the illumination required for the work. Intensities here listed are specified as minimum values.

result of the work of several of its committees; and the other, the first report of the Departmental Committee on Lighting in Factories and Workshops, issued also in 1915 in London.

Following the completion of the I. E. S. Code, representatives of the labor departments in Pennsylvania and New Jersey met with a committee of the I. E. S., and on June 1, 1916, as a result of these conferences, the department of labor and industry in Pennsylvania, John Price Jackson, Commissioner, adopted the I. E. S. Code in slightly modified form. Pennsylvania, by this action, becomes the first state in this country on record to adopt a factory lighting code based on definite intensities of illumination on the work.

As a basis for study and comparison, Table II has been compiled. This Table shows at a glance the various illumination intensity requirements of certain states; those of the I. E. S. Code and of the British Report; and the recommended intensities of certain authorities. It is to be noted that the intensities placed under Wisconsin have been worked up as the probable intensities equivalent to the requirements of that state corresponding to candle-power per sq. ft. specifications, and under the assumption that an overhead tungsten system of lighting with efficient reflectors is used. No actual illumination intensities are specified in the Wisconsin orders.

#### TYPES OF LAMPS AVAILABLE

The types of lamps available for factory lighting at the present time include the various electric filament lamps, namely, the carbon incandescent, the metallized filament, the tungsten or "Mazda" vacuum and the Mazda gas-filled units; the various types of mantle gas lamps; the mercury vapor glass-tube and quartz-tube units; and the various types of electric arc lamps, namely, the enclosed carbon, metallic flame (or magnetite), and the flame units.<sup>17</sup>

Of these, the most widely used types in modern lighting systems, and, in general, the most practical types for industrial service, are the Mazda and the mercury-vapor electric lamps, and the mantle gas lamps. Due to the very wide range of sizes in the Mazda units, there is practically no class of factory location for which one or another of the Mazda lamps may not be selected and used with excellent results. This fact has brought about a remarkably wide use of Mazda lamps in the industries during the past six or eight years, especially since

<sup>17</sup> It has been decided not to include in this classification, those cases where oil, acetylene, or other similar fuels are used for illumination purposes.

their manufacture has been developed to a point making it possible to use them under rough factory surroundings. In a general way, the mantle gas lamps, likewise, have been developed in such a variety of types and sizes during the past few years that they are also suitable for a very wide range of factory locations.

Since its initial application to an industrial use in this country in 1903, the mercury-vapor lamp has found wide service in such typical industries as metal working plants, textile mills, newspaper and printing establishments, and shipping and storage houses. Installations of mercury vapor lamps are on record with as many as 2,500 units in a single plant.

The notable development in the interest taken in factory lighting has been promoted very largely by the design and marketing of these modern types of lamps, and, physically speaking, the possibilities in this field are due almost entirely to the introduction of the many new types of lamps and auxiliaries, which, in turn, have made it possible to light factory spaces properly with electricity or gas, whereas, formerly, these same spaces could not be lighted properly because of a lack of suitable lamp types and sizes adapted to given conditions, such as ceiling heights, clearance between cranes and ceilings, and similar limitations.

### REQUIREMENTS

The principal requirements which should be met fully in planning factory lighting may be summarized as follows:

(a) Sufficient intensity of general illumination over the floor area to prevent accidents and to make it possible to handle material and to get around the machinery readily.

(b) Sufficient intensity of the illumination at the point of work, usually a higher intensity than in (a) although it is practical in some cases to make the intensity of the general illumination adequate for both (a) and (b).

(c) The use of suitable shades and reflectors with the lamps mounted in such positions as to avoid eye-strain.

(d) The electric circuits and gas mains of sufficient size to assure normal working pressures of the supply at all times.

(e) In addition to (d) the supply should be adequately protected against interruption of service.

(f) The size of the lamp should be in accord with the ceiling height of the section where it is employed, particularly where the entire

illumination is furnished from lamps overhead, that is to say, where no individual lamps are used close to the work.

As a supplement to the foregoing list of requirements, certain specifications concerning artificial lighting as made by one of the Federal Government Departments<sup>18</sup> are of value in relation to this phase of the subject. These specifications, as abridged from the bulletin of this department, are as follows:

*General Illumination.*—The entire shop should have a system of general artificial lighting adequate to insure an illumination of not less than 1 foot-candle over the entire floor area.<sup>19</sup>

*Local Illumination.*—At the points of work, additional local illumination should be provided, or the general illumination increased, to meet the specified intensities for given classes of operations.

*Character of Lighting Units for General Illumination.*—Satisfactory units for the general illumination of shops would consist of tungsten or gas-mantle lamps provided with deep-bowl reflectors having extensive distributing characteristics. The units should be suspended as nearly as possible to the ceiling in such relative positions as to insure a minimum distribution of 1 effective lumen over each square foot of floor area, that is, a minimum of 1 foot-candle at each point of the floor area.

*Character of Lighting Units for Local Illumination.*—The additional local illumination of such cases as machines and finishing table may be advantageously secured by the use of tungsten or gas-mantle lamps and opaque reflectors with intensive distributing characteristics of the deep-bowl or cone type. Fixed suspension should be used. The height of suspension will depend upon the distribution characteristics of the reflector used.

For such cases as cutting, basting and pressing tables, the local lighting units may be made up of tungsten or gas-mantle lamps with deep-bowl prismatic reflectors of glass with intensive distributing characteristics, the height of suspension and the spacing being such as to meet the desirable intensity for the operation in question.

*Glare Effects.*—It is important to avoid all glare effects, for not only do these make seeing difficult but they are injurious to the eyes. Glare is present from any light source, under ordinary working conditions, when it is in the field of vision and is of greater intrinsic brilliance than the object to be viewed. It follows that in the local illumination of workshops, bare lamps or reflectors of the shallow-saucer type should never be used. Prismatic reflectors should be of the deep-bowl type and suspended at such heights as to cause the units to become practically concealed sources.

<sup>18</sup> Public Health Bulletin No. 71, May, 1915, J. W. Schereschewsky and D. H. Tuck. Treasury Dept., Washington, D. C., pp. 147 and 148.

<sup>19</sup> These requirements apply specifically to the workshops of the woman's garment industry.



Opaque deep-bowl or cone reflectors are always to be used for local illumination when the height of suspension is such that the unit will be within the ordinary field of vision.

All reflectors are made for use with a particular size of lamp. This specific size should always be used with the reflector. The use of larger lamps produces glare from the projecting portions and alters the distribution characteristics of the combination; the use of lamps smaller than that for which the reflector is designed constitutes an uneconomical unit, which may produce inadequate illumination and alter the distribution characteristics of the reflector.

#### SYSTEMS OF ILLUMINATION IN USE

In the earlier days, before the introduction of the mercury vapor and Mazda lamps, the use of the small carbon filament units and the large arc lamps, usually resulted in a low degree of general illumination when some of the lamps were mounted overhead, thus making it essential to employ an individual or localized lamp close to the work of each employee.

With the introduction of medium-sized lamps, that is to say, the mercury vapor and Mazda lamps, with their wide range in sizes, there has been made possible a comparatively new system commonly termed the *overhead* or *general* system of illumination, whereby a large number of medium (or even relatively small) units are mounted well overhead in such density of numbers as to furnish entirely adequate illumination at the work without the addition of individual hand or localized lamps mounted directly at the work.

Again, it is sometimes found advisable to carry out the scheme of general illumination, but instead of a uniform spacing over the entire ceiling area, to mount each lamp with respect to some given piece of machinery or work, thus forming a system somewhat between the general and the strictly localized lighting systems.

Overhead lighting may be subdivided into three general classes, namely, the *direct*, the *semi-indirect* and the *indirect* systems. For manufacturing spaces, the direct system has been, and probably is now most widely used, partly because of its higher efficiency, and partly because it is usually better adapted to factory spaces and is ordinarily cheaper in first cost than the other systems. Exceptional cases arise, however, where the semi-indirect or even the indirect systems may prove economical on account of their peculiar advantages under certain circumstances. For example, the indirect system is now used with very satisfactory results in a number of textile mills.

Furthermore, in the drafting rooms and offices connected with factories and mills, the semi-indirect and indirect systems are often used, and it seems reasonable to expect that the illumination advantages of these systems will cause them to be even more widely used under certain industrial conditions, particularly as the efficiency of the commercial light sources is further increased. Figs. 1 to 6 inclusive show three overhead systems of tungsten lighting, that is, a direct, a semi-indirect and an indirect system, and three systems where the mercury vapor lamp is employed.

#### METHODS OF CLASSIFYING LOCATIONS AND WORK

A classification of typical industrial locations and of the various kinds of work involved, is of value when planning new lighting systems where it may be important to know what intensity to select for a given factory space in terms of the experience of others under similar or somewhat similar circumstances, or when the drafting or enforcement of lighting legislation is involved.

For the reason that the industries cover an immense variety of locations and kinds of work, it is impracticable to attempt a comprehensive list of all industries, and the following cases are therefore given merely as typical of some of the efforts which have been made to formulate classifications of this general nature. They are intended, for the same reason, to serve rather as a guide, and the references made to a number of books and pamphlets will aid the reader to continue the study further if these more or less typical classifications are found to be inadequate.

The Code of Factory Lighting<sup>20</sup> issued by the Illuminating Engineering Society attempts a broad classification under four headings, as follows:

1. Storage, passageways, stairways, and the like.
2. Rough manufacturing and other operations.
3. Fine manufacturing and other operations.
4. Special cases of fine work.

It is obvious that in a general summary of this nature, many uncertain cases will naturally arise in the inspection of, or dealings with, different factory buildings. In the code of the Illuminating Engineering Society the suggestion is made that this general classification be followed and that uncertain cases be left to the judgment of a lighting expert. The lighting expert, if thus called upon to make a

<sup>20</sup> Trans. I. E. S., vol. X, Nov. 20, 1915, pp. 605-641.

decision on such uncertain cases, may depend on a more detailed subdivision with intensities specified for locations intermediate between the main headings just listed.

The Departmental Committee on Lighting in Factories and Workshops in Great Britain, in its first report, which was limited to include the engineering, textile and clothing trades, subdivided its recommendations under a classification as follows:

1. "Working areas" of workrooms.
2. Foundries.
3. All parts of factories and workshops not included in 1.
4. Open places in which persons are employed and dangerous parts of the regular road or way over a yard or other area forming the approach to any place of work.

In its handbook on shop lighting for superintendents and electricians, issued in 1914 by the Industrial Commission of Wisconsin, the following subdivisions are listed:

1. Departments with ceilings 11 to 16 feet in height, where there is no gas or smoke.
2. Departments with ceilings 9 to 11 feet in height, where there is no gas or smoke.
3. Foundries and forge shops.
4. Stairways.
5. Platforms.
6. Driveways and passageways between buildings.
7. Yards.
8. Individual machines.
9. Benches.
10. Drafting tables.

As typical of some of the more complete classifications in use, the following subdivisions<sup>21</sup> under the general heading of machine shops, indicate one way in which some of the operations carried on in such departments have been outlined:

1. Bench work<sup>22</sup> (fine).
2. Bench work (rough).
3. Lathes (fine work).
4. Lathes (automatic).
5. Millers and shapers.
6. Planers.
7. Drills.
8. Buffers and grinders.
9. Saws.

<sup>21</sup> General Electric Company's "Handbook on Incandescent Lamp Illumination for 1916, p. 109.

<sup>22</sup> Bench work is further classified as follows: (a) single benches along the wall; (b) single benches away from the wall; and (c) double benches with operators on both sides.

10. Assembling, erecting and inspecting.
11. Painting.

#### TABULATION OF INTENSITIES COMMONLY RECOMMENDED

Any attempt to tabulate illumination intensities *commonly employed* for various industrial conditions, is rendered impracticable, partly because of lack of data on existing systems, and also because a table of this kind would tend to mislead on account of the inadequate values of the illumination so commonly found in many existing factory lighting systems. It is perhaps better, therefore, to make up a tabulation of this nature in the form of *recommended* values, as indicated in the following paragraphs. Reference, in this connection, should be made also to Table II in Section 2, headed *Summary of Factory Lighting Legislation*, where the intensities recommended by various authorities are given for a very limited classification of work.

*General Illumination.*—The United States Health Service<sup>23</sup> recommends for garment working establishments, 1.0 foot-candle over the entire floor area. The British Report for 1915 recommends 0.25 foot-candle without regard to the needs of the work itself. The General Electric Company<sup>24</sup> recommends 1.0 to 2.0 foot-candles for general illumination when supplemented by localized light.

In all of these recommendations, an effort is apparent to make sure of sufficient illumination over every factory area so that the operators may carry on their work without risk of accident and without loss of time. From the data available at this time, an average of about 1.0 foot-candle would appear to be about the minimum with somewhat higher values under particular circumstances.

*Intensities for the Work.*—When the general illumination is not supplemented by localized light, then the intensities from the overhead lamps should closely approximate those required when localized units are mounted close to the work. The recommended intensities shown in Table III may, therefore, be interpreted as a measure of the illumination which should be furnished to the work for the various operations listed, whether from localized or from overhead lamps as the case may be.<sup>25</sup> Care must obviously be taken in the use of a

<sup>23</sup> Public Health Bulletin No. 71, May, 1915, p. 147.

<sup>24</sup> "Handbook on Incandescent Lamp Illumination" for 1916, p. 147.

<sup>25</sup> This table has been compiled from the following sources: I. E. S. "Code of Lighting for Factories, Mills and other Work Places;" G. E. "Handbook on Incandescent Lamp Illumination;" United States Public Health Bulletin No. 71; Clewell's "Factory Lighting;" and the "Electrical Salesman's Handbook" issued by the National Electric Light Association.

TABLE III.—INTENSITIES OF ILLUMINATION RECOMMENDED FOR VARIOUS CLASSES OF WORK

	Foot-candles		Foot-candles
Bakery.....	2.0- 3.0	Packing and shipping:	
Bench work:		Ordinary work.....	2.0-3.0
Rough.....	1.5- 5.0	Fine work.....	2.0-5.0
Fine.....	3.5-10.0	Paint shop:	
Box factory.....	2.0- 4.0	Coarse work (first coats)....	2.0-4.0
Book binding:		Fine work (finishing).....	4.0-8.0
Cutting, punching, stitching.	3.0- 5.0	Passageways.....	0.25-0.5
Embossing.....	4.0- 6.0	Pattern shop (metal).....	4.0-6.0
Folding, assembling, pasting.	2.0- 4.0	Pottery:	
Candy factory.....	2.0- 4.0	Grinding.....	1.0-2.0
Canning plants:		Pressing.....	2.0-4.0
Coffee roasting at tables....	3.0- 4.0	Power house:	
Filling tables.....	1.0- 1.5	Boiler room <sup>27</sup> .....	0.8-1.5
Packing tables.....	1.0- 2.0	Engine room.....	2.0-3.5
Packing tables (dried fruits).	1.5- 2.5	Preserving plant:	
Preserving cauldrons.....	2.0- 2.5	Cleaning.....	2.0-4.0
Pressing tables.....	1.0- 1.5	Cooking.....	2.0-3.0
Shipping room.....	1.5- 2.5	Printing:	
Cotton mill weaving <sup>26</sup> .....	2.0- 4.0	Presses.....	3.0-5.0
Dairy or milk depot.....	2.0- 4.0	Type-setters.....	6.0-8.0
Drafting room.....	7.0	Sheet metal shop:	
Electrotyping.....	3.0- 6.0	Assembling.....	2.0-4.0
Factory:		Punching.....	3.0-6.0
Assembling.....	4.0- 7.0	Shoe shops:	
Drills.....	2.0- 4.0	Bench work.....	2.0-5.0
Millers.....	3.0- 6.0	Cutting.....	5.0-7.0
Planers.....	3.0- 5.0	Silk mill:	
Rough manufacturing.....	1.25-3.0	Finishing.....	3.0-5.0
Fine manufacturing.....	3.5- 6.0	Weaving.....	4.0-6.0
Special cases of fine work....	10.0-15.0	Winding forms.....	2.0-4.0
Forge and blacksmithing:		Stairways.....	0.25-0.5
Ordinary anvil work.....	2.0- 4.0	Steel work:	
Machine forging.....	2.0- 3.0	Blast furnace (cast house)....	0.3-0.5
Tempering.....	2.0- 4.0	Loading yards (inspection)...	0.3-0.5
Tool forging.....	3.0- 5.0	Mould, skull cracker and ore	
Foundry:		yards.....	0.1-0.3
Bench moulding.....	1.0- 3.0	Open hearth floors (soaking	
Floor moulding.....	1.0- 2.0	pits and cast house).....	0.1-0.3
Garment industry:		Rolling mills.....	1.0-2.0
Light goods.....	5.0	Stamping and punching sheet	
Dark goods.....	7.0	metal.....	2.0-5.0
Glove factory:		Stock room.....	0.8-2.0
Cutting.....	5.0- 6.0	Threading floor of pipe mills.	1.0-2.0
Sorting.....	6.0-10.0	Transfer and storage bays....	0.5-1.0
Hat factory:		Unloading yards.....	0.1-0.3
Blocking.....	4.0- 6.0	Warehouse.....	0.5-1.0
Forming.....	3.0- 5.0	Stock rooms:	
Stiffening.....	2.0- 4.0	Rough materials.....	1.0-3.0
Jewelry manufacturing.....	3.0- 8.0	Fine materials.....	2.0-4.0
Knitting mill.....	3.0- 6.0	Storage.....	0.25-0.5
Laundry.....	3.0- 5.0	Wire drawing:	
Leather working:		Coarse.....	2.0-4.0
Cutting.....	4.0- 6.0	Fence machines.....	2.0-5.0
Grading.....	6.0- 8.0	Fine.....	4.0-8.0
Meat packing:		Wood working:	
Cleaning.....	2.0- 3.0	Rough.....	2.0-4.0
Packing.....	2.0- 4.0	Fine.....	3.0-5.0
Offices.....	3.0	Woolen mill:	
		Picking table.....	2.0-4.0
		Twisting.....	2.0-3.0
		Warping.....	3.0-5.0
		Weaving.....	4.0-0.6

<sup>26</sup> See also G. E. "Handbook on Incandescent Lamp Illumination" for 1916, pp. 103-107.<sup>27</sup> Supplemented by individual lamps at the gauges.

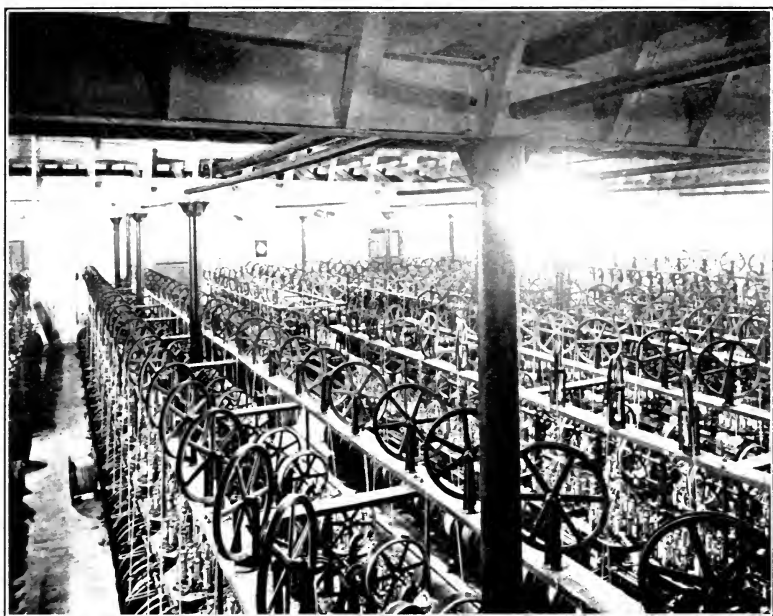

Fig. 5.—Insulated wire department with a system of mercury vapor lamps.



Fig. 6.—Hand press room in bureau of engraving and printing showing use of mercury vapor lamps.

*(Facing page 350.)*



Fig. 11.—Auxiliary or emergency scheme of lighting.

table of this kind, because the values of intensities listed may sometimes be based on experience in a limited set of conditions. Each new location should, therefore, receive sufficient study, at least, to ascertain whether the conditions warrant the selection of an intensity value as listed in this table.

### TYPICAL PLANS

Perhaps the most apparent and important need in planning factory lighting is to be familiar with the best methods for replacing a few large units for a given floor area, with a relatively large number of medium sized or even small units. Fig. 7 shows an excellent example of an old installation where a single large lamp<sup>28</sup> is suspended near the center of the aisle with large separation distances between units down the aisle. The chief disadvantages in a scheme of this kind are: first, the very poor distribution of the light, resulting in high intensity values at certain parts of the floor area (usually near the lamps for such low mounting) and very low intensity values at points relatively not very remote from the lamps; second, the severe tax on the eyesight, produced by the glare and by the concentration of all of the light furnished such a double bay, in one large unit at its center; and third, the very objectionable flicker of such lamps if the voltage conditions of the supply circuit happen to be poor.

In Fig. 8 one typical solution of the case shown in Fig. 7 is indicated. Here nearly twenty smaller lamps<sup>29</sup> replace the single large unit, since there is only one lamp in Fig. 7 for each two bays. The results from an installation like that of Fig. 8 are much improved over the older plan, the illumination being very uniform over the entire floor area and the disadvantages of the single large lamp being almost entirely eliminated.

In Fig. 9 the use of one flaming arc lamp for every two bays is contrasted with the use of sixteen 100-watt vacuum tungsten lamps for the same area. The first-mentioned case is more or less representative of many older schemes of lighting which were dictated by the lack of smaller or medium-sized lamps; while the latter case showing the many smaller units is representative, in like manner, of the application which has been made in many factory spaces of the tungsten units. It is comparatively easy to see that the distribution

<sup>28</sup> Actually an inclined electrode, short burning, flame carbon arc lamp.

<sup>29</sup> 100-watt vacuum tungsten lamps under the mezzanine floor and 250-watt lamps of the same type on the 20 ft. ceiling line. Prismatic glass reflectors are used for both sizes of lamps in Fig. 8.



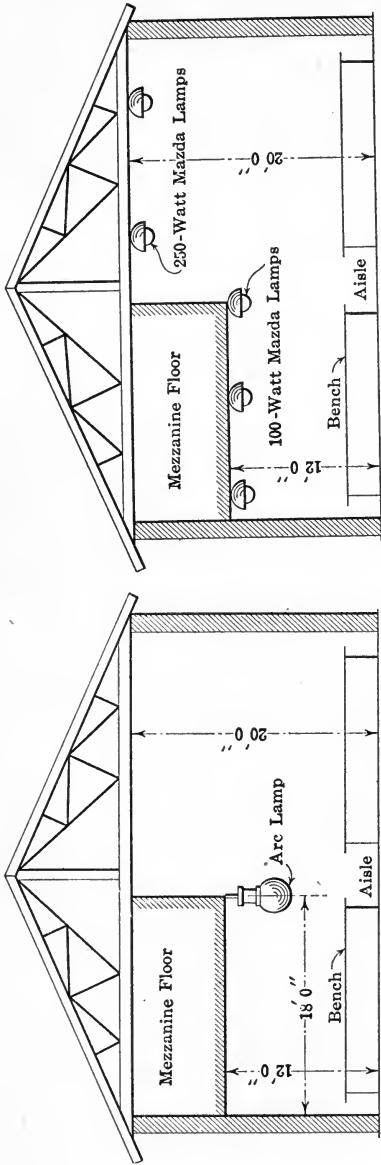

Fig. 7.—Example of an old installation where a single arc lamp is used in every other bay. Very poor arrangement. Compare with Fig. 8.

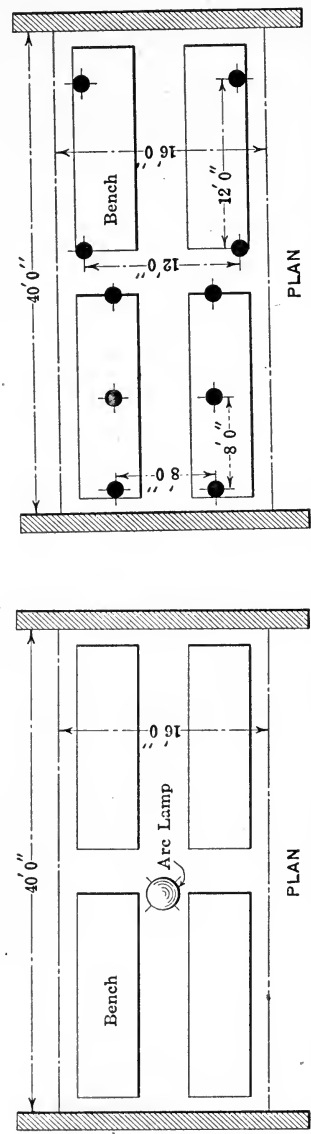

Fig. 8.—One way in which to remedy the very poor conditions of Fig. 7. Note particularly the use of small and medium sized lamps in this case.

will be vastly more uniform with the larger number of lamps, although comparative illumination tests with portable photometers under two systems like these, render the conclusions even more convincing.

As an example of different points of attack in two factory sections with the same dimensions (floor area and ceiling height) Fig. 10 is shown. Here the kinds of work are the important factors. To the left, the large cylindrical tanks require considerable light on the in-

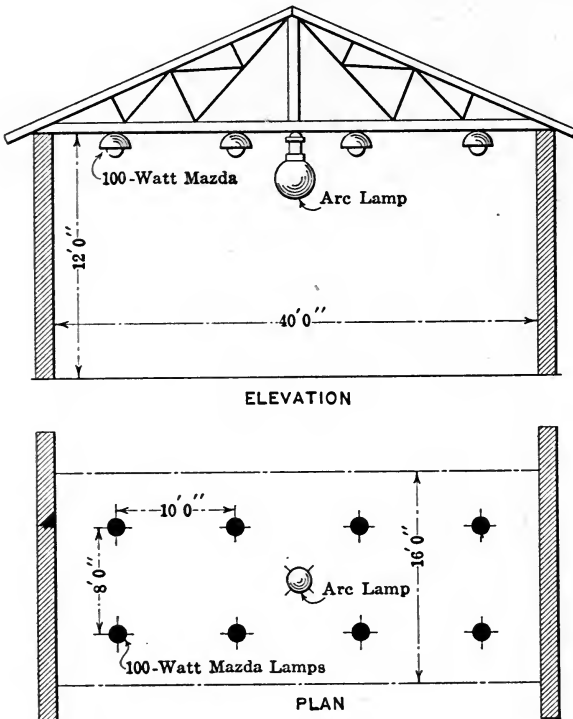

Fig. 9.—View in which a comparison is shown between the use of one large lamp in every other bay and sixteen relatively small tungsten units in the same area.

side surfaces and thus make it almost essential to use enough overhead lamps to reduce the possibilities of dense shadows on the inside of the tanks. Of course, the use of one large flaming arc lamp at the center of every other bay as shown, results in dense shadows on the inside of practically all the tanks unless a tank happens to be almost directly beneath a lamp. The use of six 250-watt vacuum tungsten lamps with prismatic glass reflectors spaced 12 feet apart, proved, under trial, a very much more satisfactory scheme.

In contrast to the left-hand portion of Fig. 10, the right-hand portion may be studied with profit. Here a single large flaming arc lamp was formerly used for the bench surface illumination, but, because of the poor distribution, drop cords and localized lamps were needed to supplement the general illumination produced by the single arc lamp. The use here of 250-watt vacuum tungsten lamps

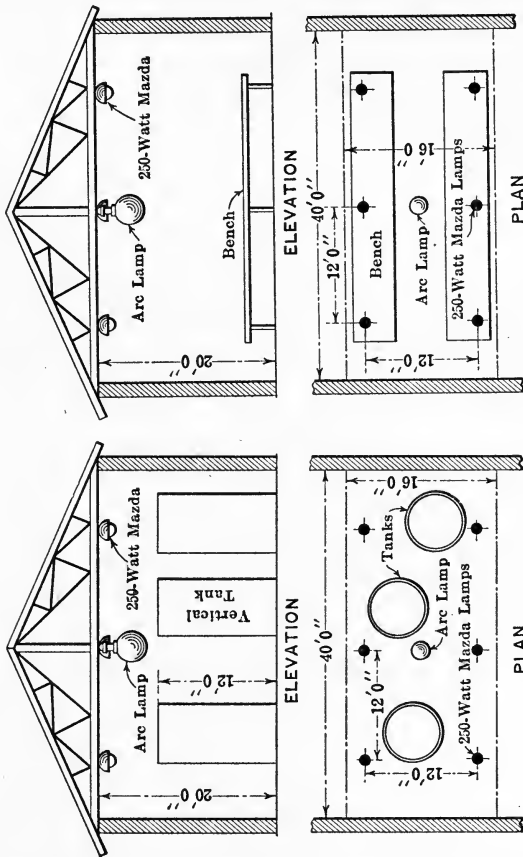

Fig. 10.—This diagram illustrates two of the possible points of view from which the lighting of a factory section may be approached, based on differences in the kind of work performed in the two sections. Note that the dimensions of floor area and height are the same in each case.

to replace the arc lamps was based largely on the desire to produce an almost uniform horizontal illumination intensity over the entire bench areas, whereas in the case of the tanks, reduced shadows probably formed the most important single factor. In the bench section, the use of the 250-watt units eliminated the need for localized lamps, giving the space a much more pleasing appearance and actually rendering more bench area available for work.

The foregoing cases are typical of several actual locations with the corresponding solutions of the given problems, and it will be noted that in each case the improved scheme was made possible by the availability of a small or medium-sized type of lamp, and the economy with which a relatively large number of such lamps can be used overhead. To demonstrate the practical nature of such an improved installation as compared with the older practice of using very large units sparsely scattered over the ceiling area, it is usually a good plan first, to demonstrate that the actual yearly cost of such an improved system is a very small percentage<sup>30</sup> of the actual annual outlay for wages in the given section; and second, to make a sample installation in several bays, which contain active work.

This procedure will usually prove conclusively to the manager or owner that the investment represents not merely an expense in the ordinarily accepted meaning of the term, but that it is an outlay which will be accompanied with more or less tangible returns because of a better and larger product for the same wages as were previously expended under the conditions of the older inferior lighting conditions.

#### DISTRIBUTION CIRCUITS

In motor driven factories, there is sometimes a tendency to supply energy to motors and lamps from the same circuits. The motor load, however, will most likely be a much larger proportion of the total than the lighting load, and, due to possible excessive variations in the motor load, there is a likelihood that the voltage fluctuations at the lamps will be unduly large.

Where tungsten lamps are employed, large variations in the supply voltage do not materially affect the life of the lamps,<sup>31</sup> but the candle-power and hence the illumination will vary over wide ranges. With some other types of lamps, excessive voltage fluctuations may cause more serious difficulties. As a general rule, therefore, motor and lighting circuits should be separate and the circuits individually designed and the loads on each kept down to such values as to insure approximate constancy in the lighting circuit supply voltage at all times.

For tungsten lighting, 110-volt mains are usually best, because of the higher efficiency and lower first cost of 110-volt lamps in contrast to those of the 220-volt class. If 220-volt service exists and

<sup>30</sup> The percentage should be worked out numerically.

<sup>31</sup> Bulletin 20, Engineering Dept., National Lamp Works, General Electric Co., p. 19.

tungsten lamps are to be used, arrangements may be made for 110-volt operation. On alternating-current circuits, a frequency of 60 cycles per second is preferable to one of 25 cycles per second, but tungsten lamps are operative on 25 cycle circuits with a very fair degree of satisfaction.

*Switch Control.*—In the switch control of a lighting system composed of a large number of small lamps, it will usually be economical to connect a small group of lamps so that it may be controlled from a single switch. However, where the energy cost is low and the installation expense for switch circuits is very high, it is well not to go to extremes in the subdivision of the circuits. As a general rule, the lamps should be grouped in rows parallel to the side walls containing windows.<sup>32</sup>

*Emergency Lighting.*—The Illuminating Engineering Society's Code of Factory Lighting in Article XI, calls for *auxiliary lighting* in all large work spaces, such lamps to be in operation simultaneously with the regular lighting system, so as to be available in case the latter should become temporarily deranged.

In Section XVI of the descriptive portion of this code (p. 44) this point is emphasized as follows:

“The auxiliary system of lighting called for in Article XI of the code, is a safety-first precaution, which is insisted upon in a large proportion of the 1200 buildings coming under the control of the Bureau of Water Supply, Gas and Electricity in New York City, particularly such buildings as are occupied by large numbers of people. The same precaution is now observed by the Bell Telephone Company's offices fairly generally throughout the country, also by a large number of private manufacturers and by local ordinances compelling all types of amusement places to take this precaution.”

The Code of Lighting for Factories, Mills and Other Work Places, adopted by the state of Pennsylvania on June 1, 1916, contains a clause, under the title “Emergency Lighting” which reads as follows:

“Emergency lighting shall be provided in all work space, aisles, stairways, passageways, and exits; such lights shall be so arranged as to insure their reliable operation when through accident or other cause the regular lighting is extinguished.”

Fig. 11 shows a space in which there are two systems of lighting (a) a number of direct units, and (b) several indirect fixtures.

<sup>32</sup> These statements apply also, in a general way, to the supply mains of gas lighting systems.

Normally, the illumination is furnished by the direct units; if these go out for any reason the indirect units are turned on *automatically*.

### MAINTENANCE

The deterioration of tungsten lamps and reflectors due to accumulations of dust on the lamp and reflector surfaces is shown graphically

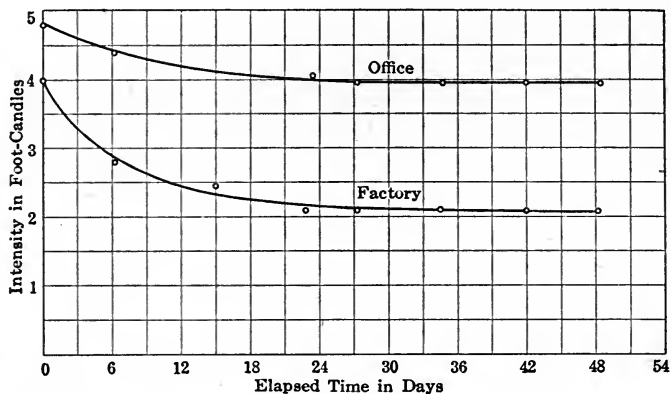

Fig. 12.—Deterioration of the same kind of lighting equipment in two different kinds of locations.

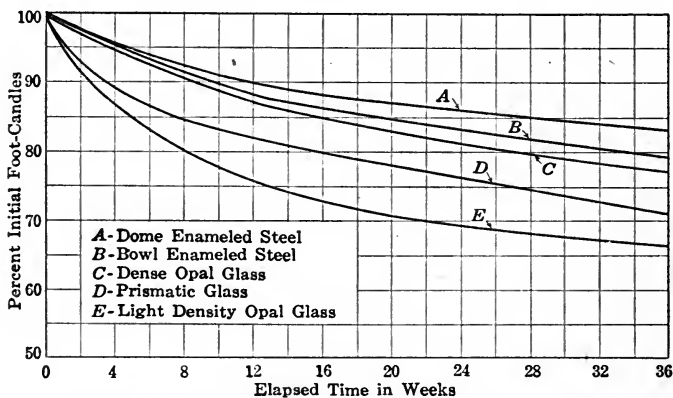

Fig. 13.—Deterioration of various kinds of lighting equipment in the same kind of location. The deterioration in Figs. 12 and 13 are due almost entirely to accumulations of dust and dirt on the lamps and reflectors.

in Figs. 12 and 13. Fig. 12 shows the rate of deterioration for a given type of lamp and reflector in two different kinds of locations; while Fig. 13 shows the deterioration rates for a number of different

types of reflectors used with tungsten lamps under one fixed kind of location.

These curves illustrate the importance of systematic attention to the cleaning of both shop windows and lighting units. With the latter, it is also very important to renew all burned out lamps promptly and to "re-carbon" the arc lamps regularly. To insure regularity in such work, it may be desirable to detail someone from the lamp or maintenance department to inspect each unit in the lighting systems at fairly frequent intervals, it being his duty to report all burned out or defective lamps as well as particular shop sections where lamps and reflectors are in need of cleaning. The cost of reflector cleaning is sometimes included as one of the fixed charges, instead of a maintenance item.

#### COST DATA

Wiring and installation expense in factory buildings is exceedingly variable due to the extreme variety of conditions met with, and hence an idea of the ranges in cost may advantageously be given at the outset.

The actual total expense for labor and material, including lamps, reflectors and switch circuits in tungsten systems, may range from about \$3.00 per outlet (each composed of one 100-watt lamp) for wood moulding on a wood ceiling of 10 to 14 ft. height; up to about \$7.00 per outlet for the same size of lamp, for iron conduit work attached to iron trusses on a line 16 ft. above the floor. Extreme cases of very high ceilings, or peculiar difficulties in the installation of the circuits, may run this cost up to very much higher values. Obviously, also, the cost per outlet complete, will be very much larger if the first cost of the type of lamp used is very large.

In the Handbook on Shop Lighting issued by the Industrial Commission of Wisconsin (prepared by F. Schwarze) it is stated that the wire and conduit in a shop lighting installation cost 150 per cent. more than the cost of the lamp, and that the cost of the wire and knobs for open work is 125 per cent. of the cost of the lamp. The labor for a conduit installation is approximately 45 per cent. of the cost of lamp and wiring materials. The labor for an open-work installation costs approximately 50 per cent. of the cost of lamp and wiring materials. This does not include, however, the cost of the mains and distribution centers. The following two cases are given by the same authority:

## CONDUIT INSTALLATION

Tungsten lamp.....	\$0.70
Conduit, wire, etc.....	1.75
Labor.....	1.12
Reflector.....	1.25
	<hr/>
Total.....	\$4.82

## OPEN-TYPE INSTALLATION

Tungsten lamp.....	\$0.70
Wiring materials.....	0.70
Labor.....	0.70
Reflector.....	1.25
	<hr/>
Total.....	\$3.35

The total operating cost of tungsten lighting systems is very well discussed in bulletin 20, Engineering Department, National Lamp Works of General Electric Co., pp. 42 to 45, on which the following information is based:

In determining the total operating cost of any system of lighting, three items must be considered: first, fixed charges, which include interest on the investment, depreciation of permanent parts, and other expenses which are independent of the number of hours of use. Frequently this item forms the greater part of the total operating expense, yet it is only too often omitted from cost tables; second, maintenance charges, which include renewal of parts, repairs, labor, and all costs except the cost of energy, which depend upon the hours of burning; and third, the cost of energy, which depends upon the hours burning and the rate per kilowatt-hour.

The life of a lighting system depends not only upon the wearing out of parts, but also upon obsolescence. There are no installations in this country which have been in use for a period of seven or eight years which are not already obsolete. Although the lamps may be in good operating condition, economy demands that they be replaced by more efficient illuminants. There is every indication that the next few years will see even greater progress in the development of lamps and the use of light. The rate of depreciation on all permanent parts is equal to at least  $12\frac{1}{2}$  per cent. The investment required in the tungsten system is relatively very low.

Table IV, compiled by the same authority, is based on a total investment including the cost of lamps, reflectors, holders and sockets only. The investment in permanent parts is therefore the total investment less the price of the lamps. No depreciation is charged against the lamps inasmuch as they are regularly renewed. The labor item under fixed charges provides for the cleaning of all units once each month. For the smaller units with Holophane steel reflectors, the cost of cleaning is taken



TABLE IV.—ANALYSIS OF OPERATING COSTS—100 TO 130 VOLT MAZDA UNITS\*

Size of lamp, rated watts	40	60	100	150	250	400	500
Cost of Lamp, List.....	\$0.350	\$0.450	\$0.800	\$1.200	\$2.000	\$3.600	\$4.000
Cost of Lamp, Std.-Pkg. Disc.....	0.315	0.405	0.720	1.080	1.800	3.240	3.600
Cost of Reflector, Std.-Pkg. Disc.....	1.155	1.292	1.566	1.653	1.653	2.617	2.617
Cost of Unit, Std.-Pkg. Disc.....	1.470	1.697	2.286	2.733	3.453	5.857	6.217
Annual Fixed Charges:							
Interest on Total Invest., 6 per cent.	\$0.088	\$0.102	\$0.137	\$0.164	\$0.207	\$0.351	\$0.373
Deprec'n on Reflector, 12½ per cent.	0.144	0.162	0.196	0.207	0.207	0.327	0.327
Labor, Monthly Cleaning.....	0.240	0.240	0.240	0.360	0.360	0.480	0.480
Total.....	\$0.472	\$0.504	\$0.573	\$0.731	\$0.774	\$1.158	\$1.180
Maintenance Cost per 1000 Hours:							
Lamp Renewals at Std.-Pkg. Discount.....	\$0.315	\$0.405	\$0.720	\$1.080	\$1.800	\$3.240	\$3.600
Lamp Renewals at \$150-Contract Discount.....	0.291	0.374	0.664	0.996	1.660	2.988	3.320
Lamp Renewals at \$1200-Contract Discount.....	0.256	0.329	0.584	0.876	1.460	2.628	2.920
Energy Cost per 1000 Hours at 1c. per Kw-hr.....	\$0.400	\$0.600	\$1.000	\$1.500	\$2.500	\$4.000	\$5.000

\* The prices on lamps and reflectors upon which the calculations of this table are based are subject to change without notice; they are used here solely for convenience in engineering calculations.

as \$0.02 per unit for each cleaning. Data obtained from installations where accurate cost records are kept, show that this figure is conservative for labor at \$0.20 per hour. The cost of cleaning other reflectors is taken in proportion to the amount of labor required. Some illuminants require attendance at regular intervals; the cleaning is done at the same time and is, therefore, included under the maintenance charge. For units which require no regular attendance, the cleaning expense becomes a separate charge. It will be noted that the fixed charges form only a small part of the total operating cost for a lighting system. The folly of using cheap reflectors, which impair the efficiency of the units, is evident.

The maintenance charge is given for a 1000-hour period of burning. To find the annual charge in any case, it is necessary to multiply by the ratio of the total hours of burning to 1000 hours. Where lamps are sold at other than the prices given, the proper correction should be applied. The renewal of lamps is the only maintenance expense.

The energy cost is given for a 1000-hour period with energy at \$0.01 per kilowatt-hour. The energy cost per year is found by multiplying by the cost per kilowatt-hour in cents and by the time of burning in thousands of hours.

An example will illustrate the use of Table IV. It is required to find the total operating expense per unit per year for lighting a mill with

250-watt tungsten lamps. The lamps are burned a total of 4000 hours and are purchased as the discount obtained on a \$150 contract. The cost of energy is \$0.02 per kilowatt-hour. From the table, the following results are obtained:

1. Fixed charges <sup>33</sup> .....	\$ 0.774
2. Maintenance $4.000 \times \$1.660$ .....	6.640
3. Energy $4.000 \times 2 \times \$2.50$ .....	20.000
	<hr/>
Total.....	\$27.414

It is important when making a study of such cost data to keep in mind the underlying advantages of good light as outlined in the first part of this lecture, and to remember that small differences in first cost or in the total operating costs of two systems under consideration, should be entirely overlooked, if one system, from the illuminating standpoint, possesses any distinct advantage over the other.

#### Bibliography

Attention is called to the selected list of references pertaining to illumination design, contained in the Fourth Edition of the Standard Handbook for Electrical Engineers, p. 1162.

The sections on lamps, lighting and illumination contained in the following handbooks may also be consulted with profit:

American Handbook for Electrical Engineers, John Wiley and Sons, Inc., 432 Fourth Ave., N. Y.

Handbook of Machine Shop Electricity by C. E. Clewell, McGraw-Hill Book Co., Inc., 239 West 39th St., N. Y.

Standard Handbook for Electrical Engineers, McGraw-Hill Book Co., N. Y.

Bulletins and Data of the National X-Ray Reflector Co.

Bulletin 71, issued by the Federal Health Service, by J. W. Schereschewsky and D. H. Tuck, Treasury Dept., Washington.

Code of Lighting for Factories, Mills and Other Work Places, issued by the Illuminating Engineering Society, 1915. Contained in the Transactions of the Society.

Factory Lighting by C. E. Clewell, McGraw-Hill Book Co.

First Report, Departmental Committee on the Lighting of Factories and Workshops, Great Britain, 1915.

Handbook on Incandescent Lamp Illumination, General Electric Company, Harrison, N. J.

Handbook on Shop Lighting issued by the Industrial Commission of Wisconsin.

Industrial Lighting, Bulletin 20, Engineering Dept., National Lamp Works of G. E. Co.

Lighting Code, Pennsylvania Dept. of Labor and Industry, Harrisburg, Pa.

Publications of the National Electric Light Association.

Transactions of the Illuminating Engineering Society.

<sup>33</sup> The value is taken as in the table. It will, of course, be reduced by the difference in interest on the lamp at the standard-package price and at the \$150 contract price. The difference is practically negligible.



## OFFICE, STORE AND WINDOW LIGHTING

BY NORMAN MACBETH

The art of applying lighting units to the production of useful and artistic illumination in offices and stores has not kept pace with the development of new illuminants. This is partly due to the remarkable rapidity of this development, and partly to the fact that the later illuminants could not be effectively applied after the completion of the buildings.

A great advance in the use of artificial lighting has been made in the past decade. Too often this result has been accompanied with an unnecessary sacrifice in the beauty of the building through the use of inappropriate fixtures or the improper distribution of the light. In resisting this influence architects have sometimes neglected to provide useful illumination in keeping with present-day demands. In such cases the artistic work of the architect has often been undone by the users in the endeavor to meet their practical needs. There are plenty of examples where bare lamps of higher power have been substituted for lower-intensity frosted lamps, to the ruination of the artistic effect and a sacrifice of the physical effect. The cure for this is to provide ample artistic lighting in such a way that it cannot easily be spoiled by the inexperienced. For example, it is often practicable to provide clear lamps concealed in diffusing glassware, tinted if desired to secure a particular color effect. Pressed and blown glass in keeping with the important periods of architecture and decoration are now available, while art glass can readily be made up into any character of design.

All modern and efficient illuminants are too brilliant for use without some provision for screening and diffusion.

It is necessary to give particular attention to the proper shielding of filaments and mantles of lamps for the protection of our eyes. This shielding, whether with globes, shades, or reflectors, should be done in a pleasing manner so far as the design and general arrangement of the fixtures are concerned. To be able to see clearly and easily is the first step toward efficiency and the amount of energy necessary, while frequently the only previous consideration when speaking of "efficiency" as related to lighting, is secondary.

Calculations by the experienced lighting man are largely for a check on his judgment. This judgment is the result of experience on lighting installations and particularly from the results secured from investigations which he personally has made of previous installations. These investigations should always be accompanied with illumination and brightness measurements.

While a few years there was very little difference in efficiency between the various sizes of incandescent gas and electric lamps, largely used for office and store lighting, it was a rather general practice to check up these calculations on the basis of cubic feet of gas or watts per square foot. With the wide variation in efficiency of various sizes of lamps at this time, the more simple exact method should be adopted of basing the calculations on the total light output of the lamp in lumens or of lumens per cubic foot of gas per hour, or per watt.

It is necessary for good illumination that there should be a sufficiently high intensity, with attention to uniformity, diffusion, eye protection, appearance, and efficiency. The importance of these characteristics of good lighting will vary in different installations. Efficiency has at times been given too much attention and prominence. It is used here to refer in office, store or window lighting to that proportion of the generated light effective on an assumed plane. At times this consideration is extremely important, and at other times of practically no importance. It is necessary, of course, for the predetermining of results, to know the probable efficiency of the installation, that is, what per cent. of the total light produced by the lamps reaches the working plane. This is generally termed "utilization efficiency" and may vary from 70 per cent. to 10 per cent. or less of the total light from the lamps. It is possible to design a lighting installation which from this single standard would have a high value, but which, from the standpoint of assistance to easy and clear vision, that is, from the standpoint of good illumination, would be an absolute failure.

Within the past few years there has grown up a strong appreciation of the ill effects of bright sources on the eye and of extremes of contrast between the average brightest and darkest portions of the room. There is a tremendous difference nevertheless between equipment which without photometric tests appears to be quite similar but which, from the standpoint of distribution of light and the contrast conditions set up, may vary in efficiency upward to 50 per cent.

Indirect lighting or semi-indirect lighting in which no part of the fixture is brighter than the ceiling is generally more satisfactory than the average system of direct lighting where clerical work is done, as tests have shown that the efficiency of the eye is reduced very rapidly under any system of illumination in which light sources of a brilliancy of those of our commercial types are within the ordinary range of the eye.

Much of the so-called semi-indirect lighting is but slightly modified direct lighting. This kind of lighting with light density glassware has been most general and has undoubtedly resulted in the unjust condemnation of semi-indirect lighting as a whole. It has been shown,<sup>1</sup> however, that of the glassware on the market used for semi-indirect lighting fixtures, at least 90 per cent. of it has too high a transmission. A worthy endeavor is being made to reduce this contrast in lighting installations to within the range of 100 to 1, that is, the brightest object within the range of view should not be more than 100 times brighter than the average lower intensity. The average semi-indirect lighting installation with light density opal glass is merely an inefficient system of direct lighting. In many locations direct lighting, particularly where the ceilings are low, would better meet the requirements. In all such cases, however, very deep bowl glass reflectors having low transmission should be used. The lamp filament should be covered down to the 65° point, and it is also desirable that the lower edge of the reflector be flared out so that this part of the reflector interior as ordinarily seen be not overly bright.

There is an important difference between diffusion of light and diffusion of illumination.<sup>2</sup> Light from a single source, no matter to what extent that light may be diffused by the enclosing media would, from the standpoint of illumination on a desk, not result in diffusion. Diffusion of illumination is the important factor and is the result you secure when the light received on the surface viewed is from a number of directions. This may be secured through close spacing of units or through using the ceiling as the light distributor either with indirect or semi-indirect fixtures. Good diffusion of illumination is essential in offices, drafting rooms and similar places where glazed paper or desk tops with polished surfaces are in use. For stores, a high degree of diffusion is not so necessary and is generally present to a sufficient degree with any system of lighting because of the large number of outlets.

Maintenance of lighting equipment should not be overlooked and it is very important that arrangements be made for a proper cleaning

of the equipment at periods varying from two weeks to a month or more, depending upon the dust conditions of the location. Deterioration is less with direct lighting reflector and lamp units than with the indirect or semi-indirect units. There are locations where it would not be possible to keep indirect and semi-indirect units clean without a cleaning period so frequent as to be unnecessarily expensive. In these cases direct lighting equipment will permit of longer periods between cleaning.

It is well to remember in accepting tables of desired intensity, utilization factors or constants, and methods of calculation generally furnished by the equipment manufacturers that these values are invariably for new clean equipment. An average deterioration factor should be used of 10 per cent. to 25 per cent., depending upon whether the maintenance is likely to be good or average. In considering fixture design, it is worth while to note also the ease or difficulty as the case may be with which the equipment can be cleaned.

Fixtures should be substantial and the means of removing glassware for cleaning should be simple. Ordinary labor is generally used for maintenance and holders with springs or similar complications are not easily taken care of by the average cleaner.

#### OFFICE LIGHTING

Office employees as a class are subjected to more severe eye-strain than almost any other class of workers.

In our large cities during many hours of the day and in many instances all day, they work with a mixture of natural and artificial light. The intensities of the latter, in these days of unwise economy of energy for lighting, are rarely adequate. There would seem to be little doubt that with a mixture of daylight and artificial light, a higher intensity of artificial light is required than where artificial light alone is used. Whether this is due to a higher eye adaptation demand or to color differences, has not been decided.

The frequent use of an instrument for measuring illumination intensities cannot be too strongly recommended. In a recent installation complaint was made that the clerks were having difficulty with their eyes, although apparently the lighting installation had been given every possible design and maintenance attention. On inspection it was shown that the spacing and kind of fixtures were satisfactory, the contrast between the brightest and darkest object in the room was well within the proper range and the installation had

every appearance of being right. Illumination measurements, however, brought out the point that the average intensity was about 1.5 foot-candles which was certainly not high enough for the character of clerical work performed. A simple increase in the size of lamps used corrected the difficulty.

In a recent investigation<sup>3</sup> in a block of office buildings in New York City, over 85 per cent. of the workers were under artificial light or a mixture of natural and artificial light all day, and over 90 per cent. of them worked more than eight hours per day. Some of the clerks and stenographers had only 0.5 to 1.5 foot-candles on their work. Others again by the use of portables, mostly placed improperly, worked under 30 to 40 foot-candles, likewise suffering from headaches and eye discomfort. An entire floor of ledger keepers with a system of semi-indirect units, otherwise satisfactory, had only 0.5 to under 2 foot-candles effective at the desks. The misdirected economy demands of the office building superintendents or the competition demands of the venders of lighting equipment, to do with a less energy expenditure than necessary, was undoubtedly accountable for these installations.

Economy is frequently referred to in considering office lighting. The economy which is most lasting, however, is that which avoids the waste of human energy.<sup>4</sup>

“Such waste has no compensating return but is an irretrievable and total loss. The man who works an entire day to accomplish that which, under obtainable conditions, he could accomplish in half a day, has wasted a portion of that which is above all price—life . . . . . Poor and insufficient light is indefensible from every standpoint . . . . . The most vital of all economies is the saving of human energy . . . . . Let us not overlook the fact that we work by sight, that we see by light.”

In discussing the cost of lighting, Professor Charles F. Scott stated<sup>5</sup> that in one instance the cost of good light for an office was but 2 per cent. of the wages; that “the difference in cost between good light and poor light would be 1 per cent. of the wages,” noting that

“One per cent. of an office day was about five minutes, that if clerical work can be done with greater ease and figures read more accurately, if there is greater rapidity and fewer errors, if there is less eye strain, less headache, greater comfort and satisfaction, so that more and better work is done in eight hours than would be done in eight hours and five minutes with a poor light, then the extra cost is justified.”

It was also shown that the difference in cost of equipment between



satisfactory and unsatisfactory methods was insignificant. He advised that in determining the real value of good illumination the cost of light should be determined in terms of the total cost of production, either the labor alone, or the labor plus the various other charges which enter into the total cost of production. This was to be expressed either in per cent. or in minutes, adding that common-sense judgment is a better guide than detailed systems of cost which fail to consider the indirect and really important elements that make good illumination worth while.

In a discussion of costs for office lighting at a hearing of the Heights of Buildings Committee of the Board of Estimate and Apportionment of the City of New York,<sup>6</sup> comparing the costs of good artificial lighting service to the cost for daylight, generally considered to be free, it was stated, that, if the buildings in New York were limited to a height of three or four stories to secure the maximum angle of sky effective in the interior of these buildings, considering the ground values and office rentals per square foot per annum, the values of the remaining office space would go up enormously; that, at the present rentals, there were very few locations, particularly in the office building district, where artificial lighting could not be supplied for ten hours per day, 300 days per year, at an expense not exceeding 1 per cent. or 2 per cent., and certainly less than 5 per cent. of the present rentals per square foot per year. Two or three kilowatt-hours or 100 cu. ft. of gas per square foot per year would be sufficient energy to furnish more good illumination than 75 per cent. of the offices in New York now have. Good artificial lighting is certainly much less expensive than daylight when considered on this basis.

The load factor in a set of typical office buildings in Chicago was shown to vary from 1.5 to 4 hours per day.<sup>7</sup>

Modern office lighting practice calls for general illumination of a fairly high intensity, evenly distributed throughout the entire room, in contrast to the old method of supplying a low intensity of general lighting with points of high illumination caused by local or drop lamps over each desk. Originally this system was necessary as incandescent lamps were not efficient enough and the rates for energy were comparatively too high to warrant supplying the proper illumination throughout the entire room, but with our high efficiency illuminants and reduced rates the present system is justified.<sup>8</sup>

General lighting has become practically standard. No well posted designer thinks of providing desk lamps for typical office work. Although in the private office a different problem often arises.

Local lighting has in many instances proven objectionable as there is a great liability of glaring reflections from the desk surfaces and glazed paper. Marked contrasts often exist between the brightly lighted desk area and the rest of the room, both of which factors cause a reduction in the efficiency of the eye.

An office with a multiplicity of drop lamps is unsightly, the cost of wiring is high and there is a heavy expense when wiring is changed as the position of desks are shifted. The employees are likely to change the location of lamps by tying the wire to some stationary object, a practice which is objectionable from a standpoint of safety and forbidden by the wiring codes. Time is lost moving the light-sources about and the breakage of lamps is likely to be high.

With general lighting, overhead units are so placed that the lamps are well out of the angle of vision and are equipped with diffusing glassware. The arrangement, of course, must be such that dense shadows are avoided. Larger lamps are permissible, which, in general, are more efficient than the smaller sizes; fewer outlets are required, reducing the cost of wiring. When one stops to consider all the factors that enter into an effective lighting system he is soon convinced that general illumination is really far more economical than local lighting.

The three general types of lighting units as ordinarily recognized are direct, semi-indirect and totally indirect.

Direct lighting with efficient reflectors is unquestionably the most economical for with it the color of walls and ceilings has less effect on the resultant illumination. Direct lighting, if improperly arranged, may produce glare either from the light sources themselves or by reflection from the object lighted, or it may not distribute the light evenly and as a result produce objectionable shadows. It is not generally as decorative as the other methods. Nevertheless, thousands of satisfactory installations of good direct office lighting are to be seen, employing translucent glassware rather than opaque reflectors thus avoiding the undesirable condition of a dark ceiling and a gloomy appearance of the room.

Totally indirect lighting is probably the most "fool-proof" from a standpoint of a glaring installation. The light is usually evenly distributed and the effect comfortable. Objections have been raised that there is a total absence of shadow, making the room appear flat. If the system is properly designed, however, this is not true.

Semi-indirect lighting is an intermediate practice; it may be more efficient than totally indirect and much better for the eye than the

average direct lighting system. Semi-indirect lighting is not glaring if the proper unit is chosen; it can be made very decorative, the light can be quite evenly distributed and such shadows as are produced are soft and do not become annoying. The fact that the place where the light originates is readily discernible has a psychological effect on the average individual and is said to make people feel more at ease than under totally indirect lighting.

A semi-indirect unit, first, should be of quite dense glass; in other words, transmit but a small portion of the light if the best conditions for the eye are to be obtained. If light density glass is used, the bowl becomes very bright and the system loses many of its advantages, dropping back to the direct lighting class where a number of fairly bright objects are in the field of vision.

Second, the fixture or hanger used should be of such a length, and the socket in the proper relative position to the bowl, that the light is directed over the ceiling in such a manner as to evenly illuminate it. Many cases can be noted where the lamp is placed too low in the dish, concentrating the emitted light in a fairly narrow angle, resulting in a ring or circle of very bright illumination while between units it may be comparatively dark. At other times to get rid of this effect the lamp is raised so high that from some parts of the room the filament becomes visible, introducing glare. On the introduction of the gas-filled tungsten lamp with its rather concentrated filament, this feature became of more importance than formerly.

Third, in most localities, the glass used should be smooth inside and, preferably, outside also, as roughed glass collects dirt very readily and is difficult to clean. A plain but effective equipment of this kind is shown in Fig. 1.

Fourth, the means of suspension of the bowl should be such that there is absolutely no danger of the glassware falling and it is desirable to have some convenient means of cleaning.

Fifth, in the commercial office the decorations of the glassware, if any, should be very simple, for any appearance of excessive ornateness would be out of keeping with the character of the room. Deep crevices in the glass, although they may be decorative, are objectionable from the standpoint of dust accumulation. Fig. 2 shows a semi-indirect installation using a somewhat typical opalescent blown glass dish, 17 in. in diameter and 5 in. deep. The interior of the dish is fire polished, the exterior is roughed with an etched decoration.

There is a factor which does not enter into the choice of the unit,

but which has an important bearing on the system as actually installed, namely, is the color of walls and ceilings. With indirect systems it is very essential that the ceiling be light in color, white or slightly cream, to secure a maximum efficiency of reflection. Even with direct lighting, as part of the light goes upward, light ceilings are desirable. The upper part of the walls, also, should be light, as considerable light often reaches this part of the room. The lower half of the walls are not so useful from this standpoint, and it is often desirable to decorate these in some darker neutral tint for this is in the natural field of view and a dark surbase provides space on which the eye can rest in comfort. Matt or dull finishes are always preferable to glossy surfaces as they avoid the possibility of annoying reflections.

The single office spaces usually have desks and cases placed next to walls. Many have tables in the middle.<sup>9</sup> The center outlet system of lighting, either direct or indirect, is not considered entirely successful where desks are to be placed next to the walls. In conference rooms where the work is done around a large table in the middle, either method is satisfactory. It has been stated that in semi-indirect lighting the amount of transmitted light should be about 15 per cent. This, however, is a matter that has entirely to do with the brightness of the surroundings or the low intensity of surfaces within the range of normal observation. There are many cases where there is no apparent advantage for a single semi-indirect or totally indirect unit in the center of an office. The distributed unit system has been in use a great many years and has proven quite satisfactory. It is always subject to less deterioration from dust and is less effected by changes in color of ceilings and walls.

In planning the outlet arrangement for a large office building, it is important to anticipate a sub-division of office space as in office buildings the partition arrangements are particularly flexible, scarcely two tenants requiring a similar division of space. In many instances it is necessary to provide at least one outlet for approximately each 100 to 200 sq. ft.

*Spacing of Indirect and Semi-Indirect Units.*—Ceiling height largely determines the distance between outlets for these fixtures. This distance should be approximately equal to the ceiling height or may extend to 1.5 times the ceiling height. Where close work is to be performed a less distance should be chosen. The distance of units from the ceiling is more largely a matter of appearance from an architectural point of view. If the unit is placed where it looks as

though it belonged in the room the distribution of light can be taken care of by selecting the proper equipment for the purpose and adjusting the filament or mantle in relation to its reflector or the angle of cut-off of the unit itself.

SPACING AND FIXTURE LENGTHS FOR VARIOUS CEILING HEIGHTS,  
INDIRECT AND SEMI-INDIRECT FIXTURES

Height of ceiling, ft.	Fixture length, ft.	Maximum distance between outlets, ft.
8	1.5	7.5
10	2.0	9.0
12	3.0	12.0
14	3.5	15.0
16	4.0	18.0
18	4.5	22.0
20	5.0	25.0

Two-thirds of the above spacing distances may be used under structural conditions that warrant other spacing than given above.

### BANK LIGHTING

Artistic consideration in the lighting of banks<sup>10</sup> is very important. The architectural harmony should be given as much consideration as the utility. Present practice supplies a relatively low intensity of well diffused general illumination produced by a decorative or semi-decorative system, and a higher illumination by localized lighting at the points which logically demand this. These may be divided as follows:

*Patrons' Desks in the Banking Space Proper.*—In the center of the room, a floor outlet should supply service to a standard fitted with two brackets and diffusing reflectors, or one special trough type reflector and clear lamps. At the sides, bracket type fixtures and similar equipments meet the requirements.

*Banking Cages.*—Special cornice type, mirrored trough reflectors, or short brackets and opaque reflectors, should be located well out of the way and strong localized light provided.

*Bookkeepers' Desks.*—Local lamps with reflectors so designed and located that there is no direct reflection into the eye, should provide the desirable intensity of evenly distributed light.

For local desk lighting it is practically impossible to secure satisfactory results by placing a lamp symmetrically on a desk as shown



Fig. 1.—Office 30 ft. by 32 ft., ceiling height 10 ft. 6 in. Ceiling is matt white in color, walls medium cream. Height to bottom of units 8 ft. Seven semi-indirect lighting fixtures are used with dense opal glass reflectors. One 300-watt gas-filled lamp per outlet.



Fig. 2.—Medium-size private office. Ceiling height 10.5 ft. Ceiling finish white, walls dark cream. Six outlets are used with three 60-watt clear tungsten lamps in semi-indirect dishes at each outlet. Length of fixture 2.5 ft.

(Facing page 372.)

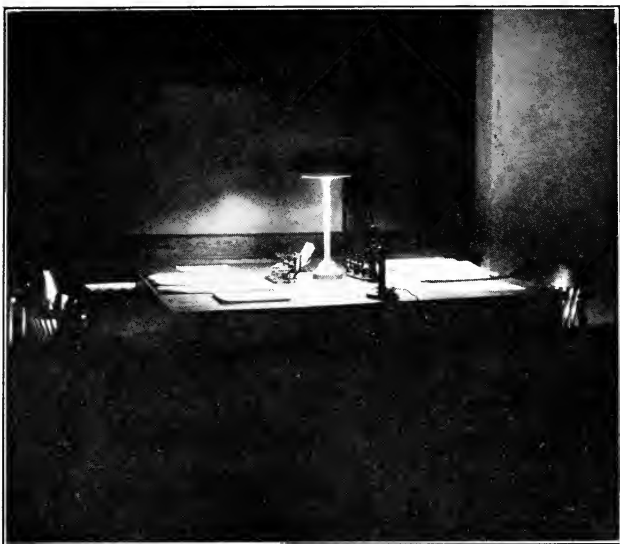

Fig. 3.—Individual desk lamp placed in the center of the desk furnishing illumination for two workers, one on each side of the desk, a frequent but most unsatisfactory location owing to the difficulty due to direct reflection.



Fig. 4.—Sales floor of large wholesale dry-goods house using a form of semi-indirect fixture with translucent bowl and wide band, the interior of which is lined with ripple mirrored glass. 250-watt vacuum tungsten lamps were used, one at each outlet, with a spacing of 11 ft. by 15 ft. On this floor the ceiling and upper side walls are finished in a flat white.

in Fig. 3, without setting up a serious condition of direct reflection from the paper surfaces on which the work is done. This placing of desk lamps symmetrically, bringing the work to be done into a direct line between the eye of the operator and the lamp, is almost universal with desk portables and is perhaps responsible for more eye discomfort than any other single condition in office lighting.

Simply shifting the portable two or three feet to the left in the case of a right hand writer, and to the right in the case of a left hand writer, will successfully eliminate this direct reflection possibility. It is rather surprising, the large number of eye discomfort cases among clerical workers that can be corrected in this simple manner. It is a general conclusion also that the lamps used in desk portables are invariably too large. There is no practical necessity of intensities beyond 10 foot-candles for this work and yet with the average portable the intensities range upwards to 25 and 50 foot-candles.

As a simple test to determine the satisfactory position on a desk at which work may be performed or to note whether a portable lamp has been moved out of the danger zone, the operator may, when seated in the regular working position, place a mirror at various parts of the working plane and take observations as to whether or not this mirror shows the reflection of a lamp or the image of any bright surface. A satisfactory working condition may be secured by either shifting the working area, or the lamp in the event of it being a portable, to such a point that all reflections seen in the mirror will be of low intensity surfaces.

Another cause of eye discomfort in offices, particularly with the liberal expanse of window surfaces now provided for in most buildings, is due to the large angle of sky within the normal range of vision. Recently, in an office in one of our large modern buildings, two stenographers after working under this condition where they faced a wide angle of sky daily for a couple of months suffered from headaches and eye-strain. One even found it necessary to wear glasses. By turning their desks around so that they faced a moderately bright wall rather than the bright sky, their eye difficulties were relieved.

#### STORE LIGHTING

The general requirements for the best illumination of stores and especially department stores, may be considered to be: First, the goods displayed should be properly illuminated. Second, there



should be absence of glare. Third, the lighting units or fixtures should be attractive in appearance. Fourth, the light generated by the lamps should be utilized efficiently.

While all of these general requirements are of great importance, the order in which they are given above may be considered the order of their importance, in the average case.

The primary requirement is to have the merchandise well illuminated. In the first place, the intensity of illumination should be sufficient. There is a tendency toward using higher intensities of illumination for artificial lighting year after year. Care should be taken, therefore, to use an intensity sufficiently high. There is no harm or discomfort to the eyes in doing this, if the eyes are properly protected from glare. Second, the distribution of illumination should be reasonably uniform. In other words, one part of the store should not be appreciably brighter than other parts.

The term uniformity is used generally to express the evenness of illumination over a working plane and is understood to refer to the values that would be shown by illumination measurements if at every point on the plane the illumination intensities were similar. Absolute uniformity of illumination, however, is never necessary in practice. The eye is not adapted to detect variations even as great as 35 per cent. in a room, provided the minimum intensity is above one foot-candle.

Third, the light should have the proper color value. The color of the light given by the standard gas and electric lamps, which are now universally used for the larger stores, is an excellent color for illuminating a large proportion of the merchandise generally displayed. This color is not true white, however, and where the goods should be shown in their true colors, the same as in daylight, the excess of red rays can be filtered out by the proper kind of glass.

There has been a great deal of discussion among lighting men on color of light for department stores. It is rather difficult to separate the demand for color in light, or rather lack of color, for a light tending toward white, from that due to the lamp and glassware manufacturers' sales enthusiasm. The fact remains, however, that ten years ago a great many department stores were lighted with direct-current enclosed arc lamps, from which a whiter light was received than that given by the incandescent electric lamps that have almost universally replaced the arcs. In the electric field the tungsten incandescent lamp is in general use to-day with isolated instances of an endeavor, either with colored glassware or colored

bulbs, to filter out some of the excess red in this lamp and so improve its color value. Very few of these attempts, however, from the standpoint of the final installation, are nearer a white light, and in many instances are less close than was the direct-current enclosed arc lamp which they replaced and which produced light of a better white light approximation more efficiently than many of these later methods. There has in the past, furthermore, been very little demand in large department stores for incandescent mantle gas lamps because of the color of the light, although from the beginning these lamps have produced a light resulting in less distortion of colors. There is an opinion that in the endeavor to see fabric, absence of predominating color in light is most important. This is not true unless greater attention is at the same time given to intensity of light. Recent tests have shown that intensities from 50 to 100 foot-candles help this situation to a greater extent than does light having the proper absence of excess color if used as an intensity of approximately 3 foot-candles, or less. Direction of light, that is, a minimum of diffused light, is especially necessary for the examination of fabrics.

Much of the talked-of demand for whiteness of light has been for "color matching." In many instances the light from our ordinary sources is better for color matching, particularly if the fabrics selected are ever going to be seen under the ordinary lighting of our homes or places of business. There are many colors that will match under white light that are far enough off under ordinary artificial light to be unsatisfactory. Accurate color matching has only been secured where the match is effective with all the light sources under which the materials will later be seen in combination. Fabrics matched under a source having for instance a 30 per cent. white-light sensation value will not necessarily match under either the ordinary artificial light of the home or of the daylight of the street.

The near white light or so-called approximate white light is useful to a more limited extent in color identification to prevent confusion in selecting a blue or a green for black, a pale yellow or orange or pink for white, etc.

Glare is produced when the light units are so bright that they decrease the ability of the eye to see clearly or cause discomfort to the eyes. The ordinary observer does not know what is the cause of his discomfort, and may not attribute it to the lighting. Customers, however, will not stay long in store where the light is trying to the eyes, even though they do not realize why they do

not feel like staying. For example, the proprietor of a large billiard room, after rearranging his lighting system along the lines of eliminating glare, became convinced that his customers were playing billiards from one to two hours longer at a session than formerly. He had not realized that his old lighting system was too glaring for comfort until he saw the difference actually working out in increased revenue from his tables.

It is possible so to light a store that the customers will feel comfortable and not suffer through abuse of their eyes, and still the goods displayed will be brilliantly illuminated. The most important thing is to have all light sources low in brilliancy at the angle at which they are apt to be viewed. It is further desirable not to have extreme contrasts of light and shadow. The latter usually takes care of itself on account of the light-colored finishes, now universally employed for ceilings, in modern stores. It is sometimes thought a desirable thing to have the light units appear brilliant so that the store will look attractive from the outside. The comfort of the customer when he comes inside, however, should not be sacrificed to obtain a brilliant and glittering appearance from the outside. The public is becoming educated along these lines and is not attracted by glare as much as formerly. Furthermore, if the goods themselves are well illuminated, the store will look attractive. This appearance of attractively good illumination may be enhanced by taking care to display goods of light color near the entrances so that the illumination will appear at its best from the outside or on first entering.

It is not necessary to go into detail regarding attractive appearance of the lighting units. Obviously, these should be pleasing to the eyes and in harmony with the surroundings. The store owner is more apt to overemphasize this point than to underestimate it in comparison with the other requirements.

Efficiency in the utilization of light is important. This point is often apt to be overlooked by the store owner. In comparing any two systems of illumination, the choice should not be made alone upon the question of appearance of the unit, or even the quality of illumination obtained. In a large store the amount of electrical energy used is considerable and it is important for the owner to get the best returns for the money.

Economy as applied to the lighting of a store must not be mistakenly understood to refer only to the cost of lamps and fixtures or the expense of operating them. This is the debit side of the

account. On the credit side are the sales that result directly from the inviting effective manner in which the goods are shown.

*Lighting Systems.*—Stores may be properly lighted by direct, semi-indirect or indirect lighting equipments.

In large stores direct lighting is usually the most preferred on account of its high efficiency in the utilization of light. Direct lighting systems vary considerably in efficiency, however, and the least efficient of these is on about the same plane as indirect and semi-indirect lighting.

Semi-indirect lighting produces to a greater extent a more thorough diffuse illumination, which is the quality of illumination obtained by having light come from a great many directions. This is accomplished by having a large part of the light reflected from the ceiling so that illumination at any one point is produced by light from many directions. Diffusion of illumination as thus produced is characterized by the absence of sharp and dense shadows and by the minimizing of high lights or glint reflections. This quality of diffusion is desirable in many classes of store lighting but not in all classes. It is undesirable, for example, in the display of jewelry, silverware, glassware, etc., where direct lighting should always be used, as high lights or glint reflections are a necessary part of the display. A combination equipment may be used to meet these conditions where, as shown in Fig. 5, indirect lighting fixtures were installed for general illumination with direct lighting units over the counters.

We secure a shadow effect with predominating direct lighting which assists the eye considerably in determining the structure of fabrics and other goods, while under illumination that is largely diffused these details disappear.

In using semi-indirect lighting it is always desirable to use a dense glass so that the maximum amount of light is reflected from the ceiling, and the bowl is low in brilliancy—preferably not much brighter than the ceiling itself. This not only gives the maximum degree of diffuse illumination, but it also reduces the liability of obtaining glare as pointed out above.

Indirect lighting has the same general characteristics of illumination as semi-indirect lighting. A high degree of diffusion of illumination is obtained by having the light come from the ceiling. It is usually considered, however, that semi-indirect lighting is more attractive in appearance on account of the illuminated bowl. With indirect lighting there is also a contrast between the dark bowl and the brilliant ceiling. Semi-indirect lighting is usually preferable on

this account, although indirect lighting is often as efficient and it gives the same desirable diffuse illumination as the semi-indirect.

*Types of Direct Lighting Equipment.*—Direct lighting fixtures may be fitted with open reflectors, enclosing globes, or semi-enclosing globes.

Open reflectors are the most efficient in the utilization of light. Prismatic reflectors, clear or velvet finish, and heavy density opal glass, are highly desirable on account of their efficiency. These may be used in single units or in clusters.

Enclosing globes are often preferred, however, in order to obtain a more distinctive appearance. Any direct lighting unit which utilizes the light efficiently, results in a great deal of the light being directed downward and at angles not far from the downward direction. This means that in standing under the unit and looking up, the brilliancy will be too great. It is not possible, however, to protect the eyes against such conditions with direct lighting. In the ordinary uses to which a store space is put, the occupants should never have occasion to look at the light units from directly underneath. Opal enclosing globes, however, which do not redirect the light in useful directions but simply diffuse it over the surface of the globe, have nothing to recommend them for store lighting except their appearance. While the brilliancy is not as great as that of a bare lamp, it is still higher than is desirable. Furthermore, the light is not distributed efficiently and the wattage required is consequently greater than would be necessary for an installation of efficient units. On the other hand, opal globes are made up in such a large variety of attractive designs that it is not possible to condemn them entirely for store lighting. When the globe is large so that the light is diffused over a large surface and when the store owner feels willing to pay the additional cost in order to obtain the appearance desired, it may be justified.

Semi-enclosing globes are usually made in the form of a flat or shallow reflector with a bowl suspended directly underneath. These are more efficient in the utilization of light than enclosing opal globes. The brilliancy of the bowl is usually even higher than the opal enclosing globes and on that account the units are not as desirable. Semi-enclosing globes of this type should not be confused with semi-indirect lighting fixtures. In semi-indirect lighting a large part of the light comes from the ceiling so that the light received on the plane where illumination is desired comes from many different directions and the illumination is diffused. In the case of the semi-enclosing globes with flat or shallow reflecting surfaces, all the light



Fig. 5.—General view of jewelry store lighted with indirect lighting fixtures for general illumination and direct lighting units bracketed out from the shelving over the counters. Store 22 ft. by 60 ft., ceiling height 16 ft. Length of fixtures 3.5 ft., using in the five outlets three 500-watt lamps and two 750-watt lamps, the latter on outlets No. 2 and 4.



Fig. 6.—View of floor of large department store using enamelled steel indirect lighting fixtures with short suspension. A better distribution of light could be secured in this kind of location if the fixtures were lower so that the ceiling would be more uniformly lighted.

(Facing page 378.)



Fig. 7.—Department store floor using single-chain fixtures with one-piece opalescent glass-ball globes. This is a typical department store floor.



Fig. 8.—Semi-indirect gas fixtures as standardized for use in a chain of grocery stores.

comes from the bowl and the reflector, and this is, of course, a much smaller area than the area of the ceiling. Semi-enclosing globes should, therefore, be classified as direct lighting units and not as semi-indirect units.

The high-grade shop is usually small in size, lavishly furnished, located in some fashionable section and handling only the best grade of goods. The proprietor is accustomed to spending large sums for rent, equipment and general upkeep and more money can be spent for individuality of layout. A distinctive lighting system is, therefore, appropriate. Artistic appearance is the predominating factor, and efficiency a secondary consideration. The lighting system should harmonize with the architecture and preferably be designed to be strictly in accord with some predetermined plan.

#### SMALL STORE LIGHTING

Small stores may be divided roughly into five groups,<sup>14</sup> the first being those requiring equal illumination on the side walls, shelves, and on the counters, as bakeries, drug stores, grocery and china stores. Stores of medium width, may be lighted satisfactorily with two rows of lamps. This will result in a high intensity of direct light on the counters and sufficient diffused light for the walls. In narrow stores, one row of lamps down the center of the store will give satisfactory results.

The second class of stores demand good illumination on the counters and a small amount of light on the side walls, such as haberdashery, jewelry, and stationery stores, in which locations, inspection of the goods is on the counter which must be lighted with a fairly high intensity with a requirement for lesser intensities on the side walls or shelving. In jewelry stores particularly, this treatment is necessary and local lighting over the counters is desired with clear lamps which result in a better appearance of engraved objects and jewels.

In the third group are stores that demand the highest intensity on the wall surfaces and a low general illumination. Art and music stores, paint and hardware stores, are in this group. In the art stores pictures are displayed on the walls, and in the music stores it is necessary to have a sufficiently high intensity on the shelving for the reading of labels on the boxes.

In the fourth group of stores are the clothing, confectionery, millinery, and shoe stores. In these locations general illumination is required with local lighting at convenient places in the clothing and



millinery stores that a proper direction of light at high intensities may enable the customer actually to see the fabrics in a manner not possible under diffused illumination with the ordinary low intensity values.

In the fifth group are the small barber and manicure shops which require localized lighting.

*Gas Lighting.*—Gas lighting is in far better condition to-day than ever before. There is a better understanding of the kind of lamps and fixtures required to meet the general demand and more attention has been given to the successful production of these fixtures. Gas companies have shown awakened interest in good gas lighting and, in many places, the consumer can count upon a grade of service not possible a few years ago. Maintenance with gas lamps, as with all of our artificial light sources, is of particular importance and in most cities to-day it is possible to secure a high grade of service from the local supply companies at a nominal charge and, in some instances, without charge. There is a strong recognition by the gas companies that their service to the consumer means lighting service rendered, rather than merely gas by the cubic foot.

Good lighting is worth its cost and the merchant to-day is more willing than at any time in the past to meet that cost.

Semi-indirect lighting with gas has proven to be entirely satisfactory. The maintenance of these fixtures is simple and the renewal cost low. A gas lighting installation similar to Fig. 8 is all that could be desired and is certainly a better proposition than has ever before been offered in gas lighting to a similar class of store.

The general rules given for the use of other illuminants may be utilized in the planning of gas lighting installations with such modifications only as may be imposed by the differences in the size of units available. For mechanical and other reasons, semi-indirect lighting is particularly favorable to the use of gas. A large number of mantles may be placed within a single bowl and lighted by means of a single pilot flame. It is furthermore unnecessary to locate the units or to select glassware with particular reference to the illumination of individual areas, and with this system it is possible to secure much higher intensities without the resulting glare that is so usual with the older types of gas lamps used for direct lighting. This kind of fixture has been recommended for all classes of store lighting with the exception of jewelry stores where direct lighting, as stated above, will give better results from the standpoint of reflection of light from silverware, cut glass, jewels, etc.

The method of store lighting in considerable use before semi-indirect gas fixtures were available is shown in Fig. 9. This illustration shows a section of a department store illuminated by means of direct lighting cluster units.

An installation where "gas arc" lamps are used is shown in Fig. 10. This was at one time the most common method of gas store lighting, largely because of the lower cost of installation and maintenance of this lamp as compared to a cluster of small lamps. It is only fair to the latter, however, to state that in many situations where costs have been analyzed, the advantage has been found on the other side, the cluster of small units being less expensive to maintain where the conditions of gas supply were favorable and less frequent attention was demanded.<sup>16</sup> This large direct lighting unit is still favored in those places where low first cost is the important consideration. Even this field is, however, being taken care of to an increasing extent by the large single inverted mantle lamp shown in Fig. 11.

#### SHOW-CASE LIGHTING

The show case is a miniature show window<sup>10,17</sup>. It should stand out in contrast to the surroundings and should have at least twice the lighting intensity of the store proper effective on its goods.

Good illumination renders sales work easier, for close selection can be made without removing the goods from the case. This decreased handling is an advantage in largely eliminating shop wear.

Show cases should be lighted by lamps placed within the case and hidden from view. The unit used must be quite small, as it must be placed at the upper edge in the corner of the case. It should harmonize in appearance with the general finish of the fittings. Lastly, the lamps used must be of low wattage to avoid heat. Tubular lamps with suitable trough or individual reflectors meet the requirements excellently, and with the line source form, as shown in Fig. 12, a given wattage is spread over quite an area.

With the counter show case the goods are viewed from above, and the general direction of light must be downward. With the high show cases, in which lay figures are on display, the light must come from an angle.

If the illumination in the store proper is not too great, 150 lumens per running foot of show case is quite satisfactory, and in cases where a high intensity exists outside of the show cases, this allowance may be increased.

There are considerable differences in the equipment offered for this work; many of the trough reflectors that may be secured for use in the front corner of the case do not screen the standard bulb lamps and even in some cases, the smaller tubular lamps that have been used, from the eyes of the clerk behind the counter. This is largely a matter of cheap equipment and lack of attention to this important point, as good show case lighting equipment can be readily secured. Fig. 13 is an illustration of an individual reflector installation with which small lamps are used.

Lamps of low wattage are necessary to distribute properly the light where the cases are relatively small and also to reduce the heating effect to a minimum. This is of particular importance in confectionery stores where heat from the larger lamps is sufficient in the summer time to melt much of the stock on display. These cases are generally of the closed type and the heat dissipation is through the circulation of air in the case and radiation from the glass surfaces. Where this heat radiation has given considerable difficulty, the problem has been met by using small candle-power, low voltage, miniature lamps in series. While this method is not generally recommended, it has met the demand where apparently nothing else would do. The total number of lamps required for a series should be kept within one case.

It is advisable when determining the intensity to use to treat all show cases in one store alike whether for light or dark goods as the character of display may be changed.

#### SHOW-WINDOW LIGHTING

Undoubtedly there has been considerable guess-work and ill-directed experiment in show-window illumination.<sup>18</sup>

Architects and builders have apparently given very little consideration to this important question. The space in the window at the disposal of the window-lighting specialist is frequently a matter of a few inches.

We have only to observe the show windows in our home city to realize that this very important problem of illumination has been given very little consideration. Windows high or low, shallow or deep, are frequently given the same treatment. Windows containing dark goods adjoining displays of light goods are given the same quantity of light. Little attention has been paid to the amount of reflection from materials or fabrics, or to the quality or quantity of either goods or light. Windows finished in light wood or decora-



Fig. 9.—Small department store using three-lamp fixtures with single inverted mantle gas lamps with prismatic reflectors. Fixture length 2 ft.



Fig. 10.—A plant and seed store using inverted mantle "gas arc" lamps. This type of installation is favored in those places where low first cost is the most important consideration.

(Facing page 382.)

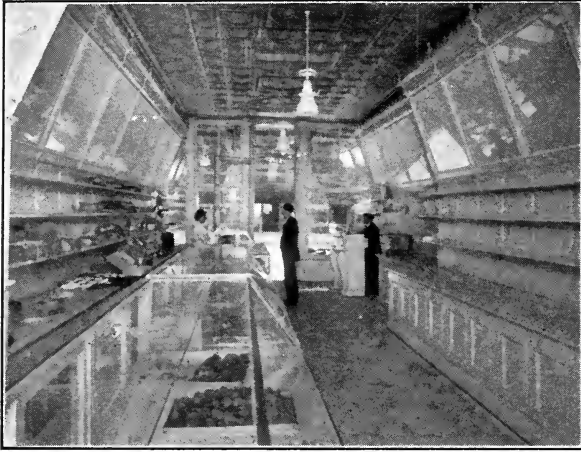

Fig. 11.—Bakery store using large single inverted mantle gas lamps, store width 25 ft., spacing between outlets 10 ft. Height of ceiling 12 ft., height of lamps 8 ft.



Fig. 12.—Show cases with small continuous trough reflectors using 11 in. tubular lamps with single straight filament and contacts on each end of the tube. This equipment for case lighting occupies a minimum of space in the corner of the case and is reasonably inconspicuous.



Fig. 13.—Show case lighted with small individual reflectors using 15-watt round bulb candelabra base tungsten lamps. These reflectors are usually installed on 10-in. to 24-in. centers. The reflector equipment is also adapted to small lamps and medium screw-base receptacles.

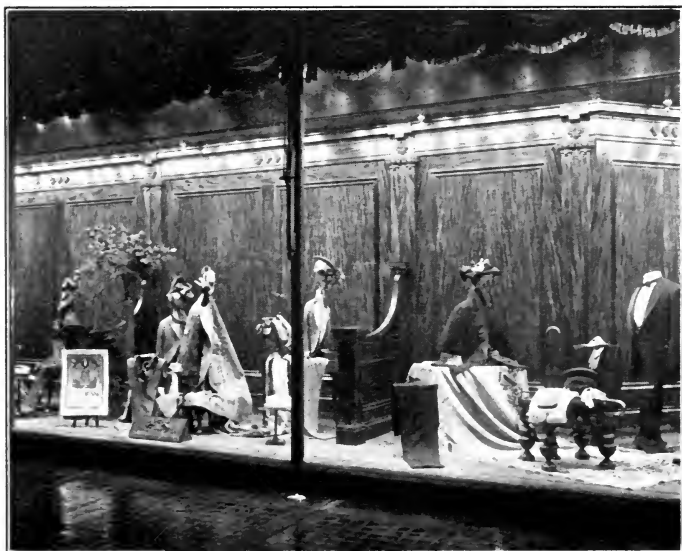

Fig. 14.—Show window using concentrated single-piece mirrored glass reflectors with 100-watt vacuum tungsten lamps on 15-in. centers. Curtain used at top of window to screen view of the lamps. Depth, 7 ft. height, floor to ceiling, 11 ft.

(Facing Figs. 11 and 12.)



Fig. 15.—Appearance at night of show window, a vertical section of which is shown in diagram, Fig. 18.



Fig. 16.—Show window, open in the back. Lamps in trough reflector screened from the view of those in the interior.

tions may have been properly and sufficiently illuminated, but when the style of the decoration changes to mahogany or dark oak, the illumination falls off so much that the window lighting comes in for severe condemnation on the grounds of deterioration in the accessories, or gross carelessness in permitting the pressure of the supply to drop off.

Seldom has the fact been made plain that because of the darker finishes a corresponding increase in intensities or change in distribution of light flux is necessary.

In perhaps no other location can the merchant secure a greater return on his investment than with the comparatively small outlay for effective show-window lighting. Window illumination is strictly an advertising proposition and, as such, costs about 10 per cent. of that of any other equally effective medium.

The purposes of a well-lighted show window and its tasteful display of goods is to attract the passerby. A glaring light source formerly in more general use is, however, about as good as none, for the goods cannot be seen, owing to the blinding effect upon the observer. There should be no exposed lamps within the field of vision. In general, the light must come from in front of the goods to avoid bad shadows, and the background of the window should be chosen to obviate specular reflection from the lighting units.

The proper lighting of show windows has become one of great importance with merchants and is one that demands consideration as a commercial proposition. The merchant is coming more to a realization that his display windows are the medium through which a great deal of his business comes and the percentage of business that he obtains through such display either directly or indirectly depends upon the manner in which he has his windows dressed and the manner in which they are lighted in comparison with that of his neighbor merchants; assuming that the windows are equally well dressed.

*Proper Placing of Lamps for Show Windows.*—Due consideration must be given in show-window lighting of the lighting conditions on the street or on the sidewalk in front of the window, as it is usually desired to have the windows appear bright, it is necessary to take these outside conditions into consideration. Any rules given for the amount of light used in show windows are therefore subject to modification and more light would have to be used under various street-lighting conditions to secure the desired effect of brightness.



It is not at all satisfactory to light show windows from lamps in front, outside of the window. Considerable of the light from these lamps will be reflected from the outer surface of the plate glass and tests have shown that these outside lamps have a utilization efficiency in the interior of the window of only 20 per cent. of that which may be secured from lamps placed within the windows.<sup>18</sup>

The illumination of store windows can, with very few exceptions, be most effectively taken care of with lamps arranged along the front of the window, Fig. 17. The lamps should be placed high and out of the direct line of vision. In some cases it is necessary to use a painted band with a sign transparency to hide the lamps; in others, an ordinary curtain or shade will accomplish the purpose, or, where a more simple, dignified treatment is required, a wooden or metal moulding of sufficient depth may be fitted across the window between the lamps and the plate glass near the top. The lamps should be equipped with reflectors, which will direct the light downward and back into the window; this will insure the proper direction of light and natural shadows. Shadows are necessary, but should not be sharply defined. We should have no difficulty in distinguishing detail in the shadows. This unsatisfactory condition is quite noticeable in a window lighted with a single high-powered unit hung in the center of the window.

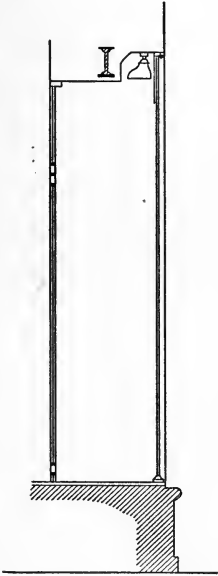

Fig. 17.—Section of window in a concrete structure where proper provision was made for the window lighting reflectors.

A window lighted from the rear and below, with the shadows upward and forward, would be little more unsatisfactory than the so-called shadowless window. All sense of size, proportion, distance and texture are lost or are so badly distorted as to repel observers rather than to attract them. Windows have been lighted successfully from the front and below where a few large objects are displayed on the floor of the window and where the height of the window or structural conditions were such as to render it difficult to light the window from above. Satisfactory installations have also been made where, in addition to the lighting from above, "foot-light" sections have been placed along the front bottom of the window. The purpose of these sections, which should contribute intensities

not more than one-third of that effective from the top of the window, is to illuminate the shadows to a lower intensity than the high lights resulting from the lamps in the upper part of the window. This system is useful in windows where the objects displayed have wide projections under which there would be heavy shadows. These "foot-light" sections are also effectively equipped with colored lamps or color filters and are used to direct colored light into the shadows for the purpose of rendering the objects displayed more attractive.

*Light Distribution Calculation.*—In high, shallow windows, concentrating reflectors should be used; while in deep windows, these reflectors would not be satisfactory. A very simple method for determining the distribution characteristics of the reflector to use is to make a scale drawing of a sectional elevation of the window, showing the height and depth, marking in the satisfactory position for the lamp from a structural point of view, and the assumed plane of illumination. Radial lines should then be drawn from the lamp center to this plane. The length of these lines can be measured with any scale, preferably in centimeters or tenths of an inch. These numbers squared will then be a measure of the proportionate intensities required for uniform normal illumination over the section of plane assumed. It may be desirable to increase the values toward the front of the window and reduce those in the rear as objects having fine detail, if placed in the front of the window, are sufficiently close to the observer, and the high intensity would be useful, whereas, in the rear of the window, it is more a matter of discerning form and outline. These values are then plotted to a convenient scale which will bring them up as shown by curve *B*, Fig. 18, and by considering this specification curve with the candle-power distribution curves of units that are available, it is a simple matter to select the one which will give the best approximation. In this instance, the solid line, curve *C*, was selected and illumination measurements afterward made in the window show the close approximation of *E*, the measured value, to *D* which was calculated, and in the vertical planes *G* and *F*, respectively. A considerable building up of the values in the front of the window can be counted upon through the reflection of light from the inside surfaces of the plate glass.

The completed window is shown in Fig. 15. Sixty-watt lamps with focusing prismatic reflectors were installed on 13.5-inch centers. The lamps and reflectors were directed backward into the window at an angle of 20 degrees from the vertical. It will be noted that there is clear glass in the upper half of the rear of this window. The

purpose of this glass is to admit daylight to the store. At night this glass is objectionable because of the reflection of the lamps and reflectors used in front of the window. This reflection could be eliminated if window shades were installed in the back of this window, on the window side. In many instances, shades have been in-

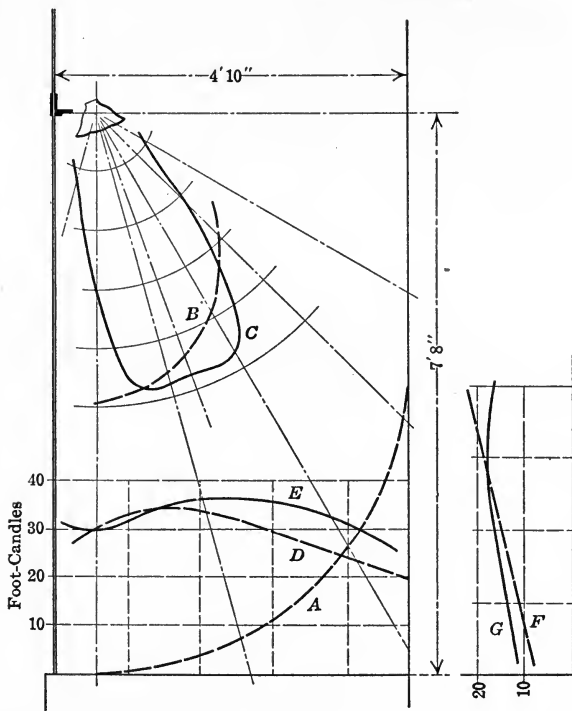

Fig. 18.—Diagram illustrating the method of calculation for the predetermination of the distribution of light in a show window; the distribution curve of the unit selected to meet the specification and also the calculated and resultant illumination values are given. *A*, is the assumed line of trim; *B*, calculated photometric curve to produce uniform normal illumination on *A*; *C*, polar diagram distribution curve of the unit installed; *D*, calculated illumination values from a unit having the distribution of curve *B*; *E*, test values of final resultant illumination on the horizontal plane; *F*, calculated vertical illumination values from unit corresponding to curve *B*; *G*, test values of final resultant illumination on the vertical plane.

stalled in locations similar to this but they are invariably improperly placed on the store side of the glass.

It is not assumed that it is correct to base all such calculations upon an average window trim for all windows. As a matter of fact the line of window trim undoubtedly differs in the majority of windows. If a window is merely flooded with light it is not neces-

sarily productive of the best results but may be an extravagant waste of energy and money for the merchant. With properly designed reflectors the goods in a window may be made to stand out more prominently with a lower power consumption than with reflectors with a distribution not conforming to that required to direct the light at such incident angles upon the goods as to cause the redirected rays to be most effective upon the eye of the observer. This is true regardless of a possible difference in efficiencies of the reflectors.

In many stores and showrooms the show windows are merely an extension of the sales floor. The windows are not backed up. It is very important in lighting a window of this kind that the lamps be screened from the range of vision of those in the store. This can be done as shown in Fig 16, where a trough reflector was used, designed in such a manner that the rear section of the trough cut off all view of the lamps from the interior, the cut-off being effective right up to the back of the window at any position above 3 feet above the floor.

*Determination of Number of Outlets.*—After the candle-power distribution characteristics of the unit have been settled upon, it has been found sufficient to multiply the floor area, in square feet, by the illumination desired in foot-candles, then multiply this result by a value which will range from two to five or more, depending upon the efficiency of the light distribution. This result will be the total lumens required, which amount divided by the total lumens per lamp, will give the number of lamps. It is important to provide in the placing of these lamps for ample illumination at the ends or sides of the windows. The center will be well taken care of from the contributions from practically all of the lamps in the row unless exceedingly concentrating reflectors are used. In fact, it is desirable to use a wider spacing of units in the center of the window than at the ends. Many illumination measurements made in existing window installations show that with a uniform spacing of lamps, the illumination intensities are very much higher in the center of the window than at the ends. This is not a result of design, but of ignorance or thoughtlessness. If the intensity at the ends is satisfactory, then there is too much in the center, whereas, if the center is satisfactory, either a closer spacing of units or larger lamps should be used in the ends of the window.

Because of the amount of light absorbed by dark goods, windows where this class of goods is to be displayed should have higher intensities than where light goods only are on view. In some instances in the past, this was provided for by switching arrangements so that

when dark goods were displayed all the lamps would be in use and a proportionately less number could be turned on for light goods. From the standpoint of the merchant, this did not prove a practical consideration as in all cases investigated all of the lamps were used together. The conclusion is reached, therefore, that if dark goods are at any time likely to be displayed, the window lighting shall be designed for dark surfaces.

It is important with gas-filled incandescent lamps that they be installed in such a manner as to make it difficult, if not impossible, for the window trimmer to place goods close to these lamps or attach anything to them.<sup>22</sup> There is less difficulty with gas lamps because window trimmers have a very clear idea that with these lamps there is heat; there is, however, a sufficiently great fire risk with gas-filled electric lamps to warrant this caution, and much less of the heat association idea.

Figs. 19 and 20 illustrate the value of checking up the requirements for light distribution in a window. This was done for the window in Fig. 19 and Fig. 20 was a direct duplication of the installation in Fig. 19, made with the consent of the owners of the first mentioned window. The dimensions are identical and the same kind, size and number of lamps were used. Instead of the lamps being hung pendent with an angle reflector, however, as in Fig. 19, Fig. 20 was fitted with a very similar prismatic reflector which, instead of being pendent, was tipped up at an angle which resulted in directing most of the light into the upper rear part of the window.

The methods for installing gas lamps to illuminate show-window displays vary somewhat with the construction of the windows.<sup>23</sup>

In Fig. 23, are shown three methods, two for the enclosed box type window, and one for the open type.

The enclosed type of window can be best lighted by units installed in the front of the window through openings in the ceiling or deck. The lamps should be provided with reflectors to direct the light downward and back into the window. A valance or screen should be placed at the top to result in a finished appearance and to hide the reflectors. There should be openings in the floor of the window to admit fresh air. These openings are to be connected to air ducts over which cheesecloth has been stretched to prevent dust being carried into the windows and to check the direct flow of air which might cause sudden draughts. The cheesecloth can be stretched on a wooden frame of such construction as to permit of its easy renewal. The glass in a show window so ventilated will not "sweat" and, as



Fig. 19.—Show window in which the arrangement of lamps and reflectors was carefully calculated. The average intensity in this window was 30 foot-candles.



Fig. 20.—Show window constructed in practically every particular similar to Fig. 19. These two photographs were made on the same kind of plate and were given the same time of exposure, development and printing.

(Facing page 388.)



Fig. 21.—Show window of the boxed-in type illuminated with five single inverted mantle gas lamps installed over glass panels in the ceiling of the window close to the plate glass.



Fig. 22.—A deep enclosed window with glass panels in the ceiling above which gas lamps with concentrating reflectors are used.

a consequence, will be free from frost during cold weather. The arrangement of the air ducts, ventilators, and lamps causes a current of air to pass constantly across the back of the glass. In any window where sweating is noted, it is merely necessary to arrange the lamps, fixtures, and ventilators in such a manner as to produce a circulation of air over the entire surface of the glass and the trouble will disappear.

In windows fitted as shown in Diagram A, Fig. 23, the openings in the deck should be large enough to permit the lamps to be adjusted from the interior of the window. Transoms above the windows

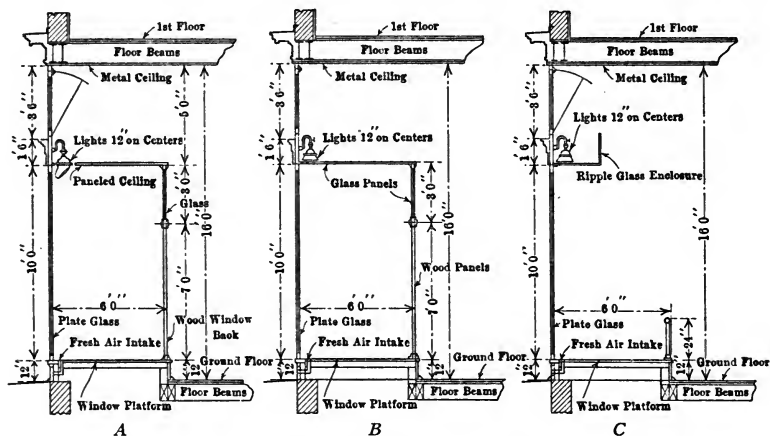

Fig. 23.—Illustrating three methods of installation for window lighting with gas lamps. *A*, enclosed type of window, lamps equipped with angle reflectors projecting through openings in the front of the deck of the window. *B*, the totally enclosed type of window, with glass panels in the front part of the deck and the gas lamps with opaque concentrating reflectors installed above this glass at a sufficient height to enable the reflectors, glassware, and mantles to be removed without difficulty. *C*, an approved method for the installation of gas lamps in the open type of window. The lamps are concealed in a box built in at the top and parallel with the plate glass, the bottom of this box being fitted with glass panels.

should extend to within 3 inches of the ceiling and should be hinged at the bottom so that when they are open they protect the lamps in the window from draught and prevent undue heat pocketing at the ceiling.

For corner show windows, windows that are shallow, or windows where the display is such that access to the window can be had only at irregular intervals, the type of construction illustrated in Diagram B, Fig. 23, is recommended. The glass panels in the front of this deck are of ripple or cathedral glass which serves to break up the image of the lamp above the glass and to distribute the light effectively



throughout the window without the absorption losses of the ground or sandblasted glass that has been used in the past. In this type of window the lamps should be installed above the glass at a sufficient height to permit the mantles and glassware to be removed. The reflectors should be opaque and of the concentrating type.

Fig. 21 shows a window of this kind in which the lamps are equipped with prismatic glass reflectors. The opaque band with translucent letters at the top of the window serves to cut off the view of the glass panels from the observer on the street.

In deep narrow windows the lighting units may be distributed over the entire deck. A window lighted in this manner is shown in Fig. 22.

For the open type of show window, the construction shown in Diagram C, Fig. 23, is recommended. The two important factors in a window of this type are: first, that the location of the lamps must be such as properly to illuminate the face of the display presented to the observer on the outside and, second, those on the inside of the store should be protected from the glare which would result with a row of open lamps used in this position. The lamps can be shielded from the interior of the store by this method as shown on the diagram. The rear section of this box may be of panelled wood or metal. The bottom of the box should be filled in with panels of ripple glass. Opaque concentrating reflectors should be used. As cathedral glass can be secured in several colors, it is advisable that the framework be arranged so that the glass can be easily removed and, in this manner, the color effects of the lighting can be varied by the use of different colored glass.

There are two practically standard methods used for igniting the lamps in these show windows. First, the jump spark system, the necessary energy for which is supplied by a battery of dry cells and, second, ignition by pilot flames. The gas supply to the lamps can be controlled by a magnet valve operated from the dry cells.

#### BIBLIOGRAPHY

<sup>1</sup> W. A. DURGIN and J. B. JACKSON.—“Semi-direct Office Lighting in the Edison Building of Chicago.” *Trans. Ill. Eng. Society.*, 1915, page 698.

<sup>2</sup> “Lighting Handbook.” *Ivanhoe-Regent Works of General Electric Co.*, 1915.

<sup>3</sup> M. McMILLAN.—“Better Lighting Supervision Would Preserve Health in New York Office Buildings.” *L. J.*, 1916, page 188.

<sup>4</sup> E. L. ELLIOTT.—“Economy.” *Ill. Eng.*, 1912, page 623.

<sup>5</sup> CHAS. F. SCOTT.—“Cost and Value of Light.” *Electric Journal*, 1910, page 333.

<sup>6</sup> “Lighting Survey.” *L. J.*, 1913, page 206.

<sup>7</sup> A. O. DICKER and J. J. KIRK.—“Lighting in Downtown Office Buildings.” *Trans. Ill. Eng. Society*, 1915, page 661.

“Lighting a Large Mail Order Mercantile Establishment.” *Electrical Review and Western Election*, 1914, page 384.

“Central Station Offices at Ann Arbor.” *Electrical World*, 1914, page 714.

F. M. EGAN.—“The Lighting of a New York Office Building.” *L. J.*, 1914, page 2.

J. D. LEE, JR.—“The Lighting of Post Office Substations in Philadelphia.” *L. J.*, 1913, page 288.

J. D. LEE, JR.—“The Lighting of Post Office Substations in Philadelphia.” *L. J.*, 1914, page 8.

<sup>8</sup> A. L. POWELL.—“Choice of a Semi-indirect Unit for Office Lighting.” *L. J.*, 1916, page 98.

C. E. CLEWELL.—“Practical Notes on Illuminating Design.” *Ill. Eng.*, 1912, page 140.

P. EVES.—“The Indirect System of Gas Lighting at the Remodeled Offices of the Indianapolis Gas Company.” *Ill. Eng.*, 1911, page 366.

J. M. COLES.—“Lighting of the Laclede Gas Light Company’s New Building in St. Louis.” *L. J.*, 1913, page 295.

T. SCOFIELD and O. H. FOGG.—“Office and Store Lighting.” *Am. Gas Lt. J.*, 1915, page 299.

“Lighting of Consolidated Gas Building, N. Y.” *Gas Age*, 1916, page 197.

<sup>9</sup> E. J. EDWARDS and W. HARRISON.—“Some Engineering Features of Office Building Lighting.” *Trans. Ill. Eng. Society*, 1914, page 164.

J. P. MALIA.—“Office Indirect Lighting.” *Electrical World*, 1913, page 335.

C. E. CLEWELL.—“Illumination Design Notes Based on the New Hill Building, New York.” *L. J.*, 1915, page 73.

T. H. ALDRICH and J. P. MALIA.—“Indirect Illumination of the General Offices of a Large Company.” *Trans. Ill. Eng. Society*, 1914, page 103.

S. G. HIBBEN.—“General Suggestions for the Proper Installation and Use of Semi-indirect Lighting Fixtures.” *L. J.*, 1915, page 145.

H. D. BUTLER and J. A. HOEVELER.—“Indirect Illumination in a Large General Office.” *L. J.*, 1913, page 196.

“Comparison of Office Building Lighting Equipments.” *Electrical Age*, 1915, page 41.

A. B. ODAY and R. E. HARRINGTON.—“Illumination Systems for Good Lighting of Offices.” *Electrical World*, 1915, page 814.

C. E. CLEWELL.—“New Lighting in the Engineering Building of the University of Pennsylvania.” *L. J.*, 1915, page 196.

W. E. CHAPMAN.—“Artificial Lighting of Typical Offices in State, War, and Navy Department Building.” *Trans. Ill. Eng. Society*, 1915, page 651.

M. SPENCER.—“Scientific Illumination of Working Surfaces.” *Ill. Eng.*, 1912, page 132.

“Unit Lighting System.” *Electrical World*, 1911, page 1512.

“Drafting Room Indirect Illumination.” *Electrical World*, 1912, page 832.

W. S. KILMER.—“Office Building Lighting.” *Electrical World*, 1912, page 264.

W. S. KILMER.—“The Lighting of an Office Building.” *Ill. Eng.*, 1912, page 223.

<sup>10</sup> “Handbook on Incandescent Lamp Illumination.” Edison Lamp Works of General Electric Co., 1916.

W. N. GOLDSCHMIDT.—“Indirect Lighting in an Insurance Company’s Office.” *Ill. Eng.*, 1911, page 140.

F. W. WILLCOX.—“The Illumination of the Turbo Drawing Office, The British-Thomson-Houston Co., Ltd.” *Ill. Eng.*, 1911, page 319.

G. H. SWANFELD.—“Lighting the Largest Publishing House in America.” *Ill. Eng.*, 1911, page 624.

L. H. SULLIVAN.—“Lighting the People’s Savings Bank, Cedar Rapids, Iowa.” *Ill. Eng.*, 1911, page 631.

S. G. HIBBEN.—“When Architect and Engineer Coöperate.” *L. J.*, 1913, page 35.

D. WOODHEAD.—“The Lighting of a Bank and a Large General Office.” *L. J.*, 1913, page 292.

“Indirect Lighting of a Bank in Los Angeles.” *Gas Age*, 1914, page 386.

F. J. MCGUIRE and F. R. NUGENT.—“The Lighting of New York’s Great Municipal Building.” *L. J.*, 1914, page 125.

C. M. BUNN.—“Concealed Lighting Fixtures in the Swedish-American Bank, Chicago.” *L. J.*, 1914, page 30.

W. R. MOULTON.—“Modern Lighting of a Bank by Reconstruction of Old Fixtures.” *L. J.*, 1916, page 102.

C. L. LAW.—“Illumination Test on Semi-indirect and Cove Lighting in a Combined Office and Salesroom.” *L. J.*, 1915, page 12.

“Cove Lighting of a Store.” *Electrical World*, 1916, page 378.

<sup>11</sup> W. S. KILMER.—“Semi-indirect Lighting Applied to Large Areas.” *L. J.*, 1913, page 40.

<sup>12</sup> W. N. GOLDSCHMIDT.—“Jewelry Store Lighting with Indirect Fixtures.” *L. J.*, 1915, page 105.

E. J. DAILEY.—“Clothing Store Lighting with Type C Mazda Lamps.” *L. J.*, 1915, page 2.

W. R. MOULTON.—“Lighting of Stores and Public Buildings.” *Electrical Review and Western Electrician*, 1916, page 918.

<sup>13</sup> A. L. POWELL.—“Large Dry Goods and Department Store Lighting.” *L. J.*, 1913, page 142.

C. L. LAW and A. J. MARSHALL.—“The Lighting of a Large Store.” *Trans. Ill. Eng. Society.*, 1911, page 186.

T. E. RITCHIE.—“Color Discrimination by Artificial Light.” *Prog. Age*, 1912, page 199.

“Filene Store, Boston.” *Electrical World*, 1913, page 579.

W. S. KILMER.—“Semi-indirect Illumination in a Department Store.” *L. J.*, 1913, page 151.

H. W. SHALLING.—“Department Store Lighting.” *Trans. Ill. Eng. Society*, 1913, page 17.

“Illumination Features in N. Y. Department Store.” *Electrical World*, 1914, pages 1134, 1145, 1397.

- "The Lighting of a Large Department Store." L. J., 1915, page 245.
- H. T. SPAULDING.—"Modern Lighting Practice in Department Store." *Cen. Sta.*, Dec., 1915, page 150.
- "Lighting Features of Department Store, Boston." *Electrical Review and Western Electrician*, 1915, page 312.
- "An Innovation in Store Lighting." *Ill. Eng.*, 1911, page 354.
- M. H. FLEXNER and A. O. DICKER.—"Illumination of a Furniture Store." L. J., 1913, page 141.
- E. F. OLIVER.—"Modernizing Furniture Store Lighting." L. J., 1915, page 153.
- <sup>14</sup> A. L. POWELL.—"The Lighting of Ordinary Small Stores." L. J., 1913, page 122.
- C. L. LAW and A. L. POWELL.—"Present Practice with Tungsten Filament Lamps—Small Store Lighting." *Electrical Review and Western Electrician*, 1912, page 775.
- C. L. LAW and A. L. POWELL.—"Small Store Lighting with Tungsten Filament Lamps—Present Practice in." *Trans. Ill. Eng. Society*, 1912, page 437.
- C. L. LAW and A. L. POWELL.—"Distinctive Store Lighting." *Trans. Ill. Eng. Society*, 1913, page 515.
- A. L. POWELL.—"Store Lighting." L. J., 1913, page 90.
- C. L. LAW and A. L. POWELL.—"Distinctive Store Illumination." *Isolated Plant*, Dec., 1913, page 42.
- A. L. POWELL.—"Shop Lighting." L. J., 1914, page 4.
- A. L. POWELL.—"Store Lighting with High Efficiency Mazda Lamps." L. J., 1914, page 166.
- <sup>15</sup> "Lighting of All-Package Grocery Stores." *Gas Age*, 1916, page 523.
- "Store Lighting." *Am. Gas Lt. J.*, 1910, page 1139.
- L. F. BLYLER.—"Lighting a High Class Haberdashery Store." *Ill. Eng.*, 1911, page 656.
- J. N. COOK.—"Commerical Lighting." *Prog. Age*, 1911, page 418.
- B. K. CARLING.—"Store Lighting." *Prog. Age.*, 1911, page 435.
- E. H. MARTIN.—"Lighting a Rug Display." *Prog. Age*, 1911, page 487.
- R. M. THOMSON.—"Holding Lighting Business." *Prog. Age*, 1911, page 610.
- E. M. OSBOURNE.—"Store Lighting with Gas Arcs." *Prog. Age*, 1911, page 987.
- J. M. COLES.—"Gas Arc Lamps in a Millinery Goods Show Room." L. J., 1913, page 125.
- J. E. PHILBRICK.—"Store Lighting." *Trans. Ill. Eng. Society.*, 1913, page 499.
- R. ff. PIERCE.—"Lighting Installation Planning." *Am. Gas Lt. J.*, 1915, page 321.
- <sup>16</sup> C. I. HODGSON.—"The Use of Detailed Maintenance Records." L. J., 1915, page 274.
- W. S. KILMER.—"Special Illumination from a Tubular Source of Light." *Ill. Eng.*, 1911, page 18.
- J. A. VESSY.—"Show Case Lighting." *Electrical World*, 1912, page 1223.
- W. S. KILMER.—"Modern Show-case Lighting." *Electrical Review and Western Electrician*, 1913, page 162.

"Indirect Lighting in a Large Retail Clothing Store." *Electrical Review and Western Electrician*, 1913, page 670.

H. B. WHEELER.—"Lighting by Indirect System High Class Stores." *Electrical Engineering*, 1913, page 439.

W. R. MOULTON.—"The Lighting of an Exclusive Clothing Store." *L. J.*, 1915, page 251.

<sup>17</sup> A. L. POWELL.—"Show Window and Show-case Lighting." *L. J.*, 1913, page 173.

F. H. M. RILEY.—"Value of the Lighting Engineer." *Electrical World*, 1913, page 407.

<sup>18</sup> Lectures, Johns-Hopkins. Ill. Eng. Society, 1911, page 778.

R. BEMAN.—"Reflection from Plate Glass." *Ill. Eng.*, 1912, page 209.

<sup>19</sup> H. B. WHEELER.—"The Illumination of the New Hub Store, Chicago." *L. J.*, 1913, page 116.

J. G. HENNINGER.—"Show Window Lighting." *Trans. Ill. Eng. Society*, 1912, page 178.

<sup>20</sup> A. L. ABBOTT and C. M. CONVERSE.—"Show Window Installation." *L. J.*, 1913, page 39.

H. B. WHEELER and J. A. HOEVELER.—"Illumination of Small Show Windows." *Electrical World*, 1914, page 335.

H. B. WHEELER.—"The Lighting of Show Windows." *Trans. Ill. Eng. Society*, 1913, page 555.

J. C. KING.—"Show Window Lighting at Stern Brothers' New Store, New York." *L. J.*, 1913, page 264.

"Show Window and Display Lighting." *Electrical Review and Western Electrician*, 1914, page 275.

C. B. PATE.—"Department Store Show Window Lighting." *L. J.*, 1913, page 170.

<sup>21</sup> E. R. TREVERTON.—"Combination Gas and Electric Office Lighting." *L. J.*, 1914, page 264.

<sup>22</sup> I. CLYDE.—"Danger in Show Windows." *Electrical World*, 1911, page 335.

<sup>23</sup> "Report of Committee on Window Display." *Proc. N. C. G. A.*, 1914, page 350.

B. F. BULLOCK.—"Window Lighting." *Prog. Age*, 1911, page 575.

A. H. JOHNSTON.—"Methods of Window Lighting." *Prog. Age*, 1911, pages 705-6.

R. M. THOMSON.—"Decked Window Lighting." *Prog. Age*, 1912, page 5.

S. SNYDER.—"Lighting a Window Display with Gas." *Prog. Age*, 1912, page 196.

<sup>24</sup> P. EVES.—"Store Window Lighting." *Prog. Age*, 1912, page 572.

## THE LIGHTING OF THE HOME

BY H. W. JORDAN

Many discussions coming under the title of illuminating engineering are so embellished and surrounded with technical terms and expressions that the mind of the average practical man becomes much confused in listening to or reading about them and he is often as much in the dark at the end as at the beginning.

The average central station operator or salesman's knowledge of illuminating terms is more likely to be limited to a general practical understanding of fixtures, lamps, candle-powers and wattages, rather than lumens, lamberts or ultra-violet radiation.

I have no intent to speak lightly of the subject as an exact science, or of the real value of technical knowledge applied to illuminating engineering; but my experience has proven to me that there is a real need of more simple information on this subject that could be applied alike by the central station man and the lighting service salesman, and it is for such men that this lecture has been prepared.

The possession by the central station man, the salesman or the electrician, of a thorough knowledge of the principles of illumination would be of the greatest advantage, but even though he appreciated that it would mean much to him, the average man will not apply himself to a technical study of these principles.

There is encountered frequently at the present time the problem of the old installations with fixtures often of barbarous design. If these were short-lived, one problem of poor illumination would be solved; but while the residence owner may quickly see the disadvantage of antiquated plumbing and remedy it, he and his antiquated lighting fixtures "grow old together." However, if the solicitor, directly in contact with the owner and the builder of the small residence, had a knowledge of even the elementary rules of illumination, there would, I believe, be a vast improvement.

The effect—whether conscious or unconscious—of the harshly or insufficiently lighted home, is as subtle and as uncomfortable in the case of a small residence as in that of the large. It is true that in the small residence the question of expense must be more carefully

considered than in the large, yet when the owner realizes that incorrect illumination often means larger bills than proper illumination, he is, as a rule, anxious to have the trouble corrected. Poor lighting is by no means always attributable to a desire on the part of the owner to economize, but is more often due to a misunderstanding as to what constitutes correct lighting.

In the lighting-service salesman's mind, selling and service should be side by side. The average residence owner must be credited with common sense, and it is reasonable to suppose that if the solicitor explained intelligently the essentials of correct illumination, the owner would not knowingly select the incorrect. When proper lighting is better understood, it, rather than economy, will be the primary factor.

I believe that the illuminating companies are alert to the beneficial results of an understanding on the part of their solicitors as to what constitutes a home correctly lighted, and desire to coöperate with architects, fixture designers and decorators in this respect. These companies do realize the great need to the public, and therefore, to themselves, of proper installations and illuminants in the home. This can be judged in a way from their advocacy of the most efficient lamps, their adherence to the policy of free advice to present and prospective customers, and to their support of the departments of illuminating engineering.

No fixed rule can be given for home lighting. There always arises the question of the use to which the rooms in the house are to be put by the individual owners, their personal tastes, whether artistic effect is desired, or whether it is entirely a question of economy. I am sure no matter what the residence owner's taste may be, there always exists the desire to have the lighting artistic and efficient and the cost reasonably low.

#### PSYCHOLOGICAL ASPECTS

The principal object in home lighting is without question the psychological. It is our earnest desire to produce a plan of illumination that will be pleasing and agreeable to those who linger in its presence. It is a recognized fact that our visual perceptions and sensations are agreeable or disagreeable, pleasant or unpleasant. The illuminating engineer must give this fact great consideration. A too brilliant light source takes away that atmosphere of restfulness nearly always desired and under it one is prompted to sit up

straight on the edge of a chair rather than to sit peacefully at ease, as one would feel like doing in the presence of a reasonable amount of light of soft agreeable colors.

After all, proper and correct illumination is that which obtains pleasing and agreeable results and effects. Surely, the emotional factor, is very important in the lighting of the home on account of its direct influence upon the emotions of both the conscious and the subconscious mind.

People have stated that the true indirect system in small interiors has a most peculiar effect on the mind; some complain that it gives them the blues, others say that it makes them feel depressed, and I personally do not favor it for residence lighting.

Psychology enters into the consideration of æsthetic effects and also the physical. It is a familiar fact that artificial lighting has been done heretofore practically with illuminants giving much yellow, the colors blue and green being deficient until very recent times. I believe that the most agreeable effects are obtained by illuminants that give a proper proportion of yellow and red. For instance, light that has a sufficient percentage of yellow and red produces a very agreeable effect upon the complexion, whereas one that does not have a sufficient proportion of yellow and red will "show up" wrinkles and freckles and produce a disagreeable, harsh appearance. This fact points directly to the advisability of using shades to tone the color.

Time will not permit going far into the psychological aspects of illuminating engineering, my intention being to mention it briefly in so far as it has a direct bearing upon the lighting of the home.

#### PHYSICAL ASPECTS

It is conceded that most of the eye troubles of to-day are traceable to the fact that we are using our eyes much more than heretofore, and that much of our reading is now done in the evening. By the infinite possibilities of lighting equipment, the problems as presented to the layman are at present, and have been for some time past, rendered comparatively easy, the limitations placed upon him being comparatively few. If he decides that one system is bad, he tries another, or increases the intensity of light, and the whole time he may be getting deeper and deeper in trouble. Here is where such unlimited freedom may and often does form a dangerous gift. The allurements to excess in the quantity of light, is always present.



In the days of our forefathers, lighting problems were very simple; the tallow candle or the whale oil lamp furnished all the light considered necessary, and in many cases the newspaper or books of those days were read by the light from the fireplace. That the percentage of eye troubles was less than at present is probably due to the fact that one could not read for any great length of time by those methods, reading matter was not as common then as now, and people usually retired shortly after dark. At the present time there is no limit to the kinds of magazines and papers possible to obtain at any newsstand, and the polish is such that most of their pages could almost be used as a reflector in a projector lantern.

There is no question that the eye has become accustomed to light received obliquely from above. This, I believe, is one of the reasons the eye is affronted by light, harsh or strong, coming too brightly from any other direction. The need of giving serious thought to the lighting of the home from a hygienic standpoint is at once apparent, because the faculty of sight is of supreme importance. The aim should be not only to have the necessary light to hold the eye to its regular work, but also give the eye its normal amount of vision. Eyesight declines with passing years, and illumination in the home must be of such a character as not to increase this disadvantage.

The old rule that light for reading should come obliquely over the left shoulder, well hints that direct rays should be kept out of the eye. In lighting a room for reading or for work that is prolonged, it is always desirable to avoid too strong shadows, and glare either direct or reflected, while not doing away with shadows altogether.

#### ARTISTIC ASPECTS

The present-day lighting service requirements in the small residences, in the homes of the middle class, is low cost and utility. In the larger residences, the homes of the rich, the selection of fixtures may be governed almost entirely by artistic considerations. Here the words science and art may be synonymous, and there arises the opportunity for the illuminating engineer to combine the two in the production of devices for agreeable and pleasing effects.

It is desirable that all illumination when possible, shall be æsthetically correct. When one considers that the quantity or quality of light, or type of fixture adds or detracts from the

arrangements and the decorative appeal of a room, one recognizes the necessity of giving these much thought. The purpose for which the room is to be used and its character must receive consideration. In the large residence, in many instances, only an artist can do justice so far as fixtures are concerned.

One of the blessings of to-day is that lighting auxiliaries are more artistically designed than heretofore, and there is not left, therefore, much excuse for inartistic lighting equipment.

In these days of period furnishings great care should be taken in the selection of fixtures. There are many cases when efficiency must be sacrificed in order to permit the use of a fixture absolutely in harmony with the surroundings and the period. For example, in a large parlor of the Louis IV period, with its gold furniture with light coverings, delicate hangings at the windows, and other decorations in keeping with the times, imagine how a shower, a semi-indirect, a true indirect, or a Colonial fixture would look! A room of this type demands a chandelier of the time with its cut-glass, and if the client really has the courage of his convictions, he may equip it with real candles; but if he has not quite reached this point, the candles can be replaced by the candle lamps which probably will be cleaner and cause less trouble.

Occasionally a dining room is furnished in early English style with the carved table the old court cupboard and the Jacobean sideboard and chairs, the setting being provided by a spacious room with patterned ceiling and oak-paneled walls. In a room of that character the ordinary stock fixture would be out of the question, and one would make use of a more ornate chandelier, multiple wall brackets and candelabra lamps.

One of the first things to understand even from the briefest study of period furnishings is that all furniture and all kinds of decoration that have come down to us weighted with historic tradition, were evolved as a natural result of certain conditions of life; hence the various types that were commonly used together, will always look well when brought together.

It is of very great importance to study the lighting problem from every angle, and if necessary to arrive at the conclusions in the selection of fixtures by the process of elimination. In no case should one upon entering a room immediately decide upon a certain type of fixture simply because he recently saw one at a fixture house that impressed him.

Artistic aspects and beauty in a room, are a matter of harmonious

relationships, and good taste in illumination demands a correct association of fixture and of light, with the proper background setting.

### PRACTICAL APPLICATION

The lighting service representative in search of the residence class of business has probably the best opportunity to start the client on the right track, because he is usually the one to come in contact with him first, and it is needless to say that he should possess a comprehensive knowledge of the subject of home lighting.

He should, of course, be familiar with the different sizes of lamps, candle-powers, wattages, cost of operation, and should possess other practical information. It is obvious that should he be possessed of technical knowledge, his value to his company might be increased; but the salesman's scientific knowledge is usually limited and perhaps fortunately so, for a technically trained man is seldom a clever salesman.

Not infrequently when a customer equips his house initially with the most efficient types of lamps, replaces the burnt-out ones with old carbon lamps, the change comes so gradually that it is scarcely noticed until the bills show nearly double as much energy used as previously, and the result is a complaint.

Another factor which enters surprisingly into the economical use of lighting is proper and convenient switching. For instance, if the entrance hall lamp is not controlled from the second floor as well as from the first, it may be left in service much longer than is necessary because some one on the way up stairs may have forgotten to turn it off, and is too lazy to retrace his steps.

Another method of wasting energy is that of the careless or neglectful person who goes down cellar to "fix the furnace" and allows the cellar lamp to remain in service all night. To obviate this condition a pilot lamp could be installed over the cellar door where it would prove as useful as one for a flatiron or a range.

Another cause of high bills is misplaced outlets. I have seen outlets so badly located that it was necessary to produce approximately 10 foot-candles in one end of a room in order to obtain the necessary 2 foot-candles at the other. Obviously, the lamps should be so placed as to produce light where it will be most used, thus not only adding to the pleasing effect of the illumination, but reducing the cost of lighting. Such matters are entirely under the control of the builder and contractor. When we realize how limited the appropriations

are for wiring some of the smaller houses, we wonder how they provide as much as they do. This remark applies principally to the "ready built" houses, where financial gain is the only thing thought of. It is unfortunate that this evil exists, but at present there seems to be no remedy.

Globes or shades, the indispensable adjuncts to the lighting fixture, are made in all shapes and sizes and of all colors of the rainbow. Some are so thin that they are of scarcely any help in concealing the lamp filament, and others are so dense that barely any perceptible amount of light can be obtained through them; both of these extremes are to be avoided. The kind of glass selected should be given considerable thought, as glass absorbs, transmits and reflects.

The safest way of protecting one's self against bad fixtures is to reduce the fixture appropriation to a point that will insure simplicity. The worst fixtures to be seen are the gaudy ones of medium price, where an effort has been made to obtain a highly decorative effect without the skill in design and finish in execution really necessary for good results.

The difference in cost of installation and fixtures between good or bad never is so wide that the builder would not select the good if he realized the evils of the bad. Houses sell more readily when they contain practical and artistic electrical equipment.

### COÖPERATION

A realization of the importance of illuminating engineering in the vast fields which are opening to us have demonstrated the desirability for the coöperation of the illuminating engineer with the architect and the decorator. A new profession, without doubt, is in the process of development. My architectural friends inform me that they are depending on illuminating engineers more and more every day for knowledge and aid. It is a fact that illuminants and new devices with their intricate details are being developed so rapidly that even those who make special studies of them can hardly keep pace. Granting this statement to be true, I fail to see how the architect or decorator can afford to spend as much time on illuminating problems as necessary, without doing so at the expense of his profession. It is, therefore, advisable for the architect and the lighting expert to work together to obtain the results for which both are striving.

The engineer should be consulted where architectural changes are

contemplated, or, where special lighting is wanted to emphasize architectural effects, and the architect has an equal right to be advised of anything that concerns the house he has designed. We have fewer occasions to consult with the decorator, but the same conditions apply.

### LIVING ROOMS

In providing the lighting for the living room, consideration must be given to the fact that of all the rooms this one is most used by the average family; as this room is utilized for many purposes, a somewhat elastic lighting scheme should be arranged. In addition to being the library of the home, it is often used for social affairs, such as card playing, and dancing, and at other times one or more members of the family and their friends simply desire to lounge about and converse. In most cases, more time is spent in reading than at anything else, and it will at once be seen that good lighting is a very necessary source of comfort and one to which the utmost consideration should be given. There are a number of ways of providing light suitable for reading.

One way would be to illuminate the room so brightly that one could see to read in any part of it, but this method would prove very costly and consequently out of the question in the majority of rooms, and certainly would not be considered artistic.

Often selection is made of a portable lamp fitted with an opaque reflector that will throw the light on the reading matter, but this type of lamp, while admirable for reading, is of so little service in the general lighting of a room that it cannot, or should not, be considered seriously in the scheme of general illumination,

Some people attempt to obtain light for reading from the chandelier above by directing the rays downward, or by attaching a short extension cord to the fixture and equipping the lamp with a prismatic or even an opaque shade. This scheme is satisfactory for the reader, providing the pages are turned at such an angle that he does not receive the glare from the paper, but it is a makeshift arrangement, unsightly, and should not be encouraged.

Often in homes where electricity is employed for lighting use is made of a kerosene lamp, commonly called a "student's lamp" for reading, not really as a matter of economy, but to do away with the supposed eye-tiring, uncomfortable glare from the incandescent lamp, which bad reputation comes from the use of a too brilliant lamp unsuitably placed. One can quite readily duplicate the

effect of the kerosene lamp with electric or gas lamps and with great added convenience.

One reason that the table lamp is commonly preferred for reading is that it does away with the glare that is likely to come from a chandelier or a bracket. Glare could be avoided by assuming a proper position for reading, by the proper turning of the pages of a book to avoid it, or by the use of suitable shading. Care should be taken to select a table lamp that gives the proper light all around the table and upon the reading matter, rather than on the top of the table, where one can consider that a large amount of the light is wasted.

The style or type of lamp does not matter much, as long as the shades are not dark and are wide enough to allow the light to cover the page of a newspaper, held by a person sitting near.

The selection of the shade for the reading lamp is one that naturally lies within the control of the purchaser. Unfortunately, he or she only too often considers the question of ornamentation before the practicability of the lamp and the use to which it is to be put. Individual taste, after all, is the root of much of the present-day evil in illumination. Naturally, in the selection of a reading lamp for the home, there is to be considered the number of persons likely to use the lamp at the same time.

If the living room is small, say 14 to 15 feet, and is furnished with a table in the center, the table is the logical place for the lamp, and there will be ample room for several persons to sit comfortably around it.

Where economy in maintenance is the object, the single table lamp for a small room can be recommended, as the same lamp can be used both for reading and for the general lighting of the room, provided it is equipped with a globe or shade that while concentrating a considerable portion of the light within the reading area, will also allow enough light to radiate in all directions to give fairly good illumination in other parts of the room. When use is made of three or four proper-sized lamps, this arrangement is admirable for reading, and one is not likely to be troubled by glare from a page of white paper because the light comes principally from one side. To supply electrical energy to the table lamp an outlet in the floor, under the table, is to be preferred and recommended. Of course, here enters the question of expense, too often uppermost in the small residence owner's mind, but the slight extra expense may be explained to him from the artistic side and the view-point of comfort. He may think

that a cord could be extended from the fixture that is likely to have been placed above to take care of the table lamp, but a cord dangling above the table is not a source of eye-gratification and always seems to have a knack of hanging in the way.

Wall brackets would hardly be required in a living-room so small, from either a practical or an artistic stand-point, but if there happened to be a mantel, and of a style which positively demanded something to satisfy the artistic taste, two tiny portable lamps equipped with small candle light sources or brackets could be placed, one on either side of the shelf. In decoration they should harmonize with the surroundings, but they have little value from a lighting stand-point.

If the living room is a large one, there will probably be two or three tables scattered about, and use can be made of a suitable lamp on each table. These lamps can be used for reading, or simply for ornamentation. A room thus equipped with lamps ornamented with colored silk or art glass shades produces a very artistic effect when in harmony with the furnishings of the room and adds greatly to its charm.

The next thing to consider is the general illumination of the above two sizes of rooms. In the case of the smaller, either direct or semi-indirect lighting would be proper. If semi-indirect is decided upon, and the height of the ceiling is about 9 ft. the top of the bowl should be from 30 to 36 in. from the ceiling. Assuming that the bowl is 6 in. deep, there would be left 6 ft. 9 in. head room. Fortunately one has a large assortment of artistic and efficient stock bowls to select from, some in colors and some white. In selecting colors in a bowl care should be taken to see that they do not clash with the furnishings of the room. If there arises any doubt on this point, the pure white will surely give satisfaction. It is an easy matter to install colored lamps of any size when a particular color scheme is desired.

In case direct lighting is the choice, use should be made of the multiple style of fixture. There are so many styles of this kind of fixture that it would be unreasonable to specify any particular one. To see that the lamps have frosted bowls and are properly shaded with soft colored shades, if desired, to harmonize with surroundings, is the most important point.

This general lighting unit should always be controlled by a wall switch conveniently located at the entrance to the room. Economically, it would be advantageous to have the units for general illumi-

nation wired in two or more circuits so that a small amount of illumination can be used when full intensity is not needed.

In designing the general illumination for a large oblong room, a more difficult problem is encountered, and it is here that the coöperation of the illuminating engineer with the architect brings about the best results. If the ceiling is plain, that is to say, has no beams and no other fancy decorations, two ceiling outlets could be provided, one in the center of each half of the room, the type of fixtures to be semi-indirect or direct, as desired. Ceiling units should be so selected and installed that they do not break up the continuity of the ceiling. If the furnishings are to be distinctive, say, for instance, Colonial, the semi-indirect type of fixture would be entirely out of place, and use should be made of special fixtures of a Colonial character. Fixtures of this type have been on the market for some time and are attractive by day and efficient by night. If the furnishings are not of any special design or period, then the semi-indirect unit could be employed.

In case of a very low or beamed ceiling, the fixtures could be omitted, and a number of multiple wall brackets supplied, for when properly designed they are very ornamental whether lighted or not. A room thus equipped with decorative wall brackets and table or floor lamps is very attractive.

In a room having a fireplace and mantel, there should be an outlet on either side, their location on or beside the chimney depending upon the type of fireplace. If the brick work extends to the ceiling and is not too elaborate, a bracket over each end of the shelf would be suitable. If ornamental brick-laying was attempted, the brackets could be installed on the wall at the sides. If the mantel is of wood and somewhat delicate in design, a more delicate type of wall bracket should be selected.

### DINING ROOM

Probably next in importance to the living room is the dining room, which in some small residences is used as a living room. Here, after the evening meal, gathers the family around the table, some reading and some otherwise engaged. In a room of this character, one would not hesitate to recommend the art glass dome provided the table is the center of attraction during mealtime and the light in other parts of the room can be to a degree subdued. The dome, if so suspended as not to obstruct the view of persons looking across the table, makes



a very effective and practical dining-room unit and is also admirable for reading.

In selecting the dome one should be careful not to obtain too gaudy colors, or one ornamented with a fringe hanging from the edge the effect of which is very disturbing by casting its scraggling alternating dark and light lines upon the faces and clothing or on books and papers.

The dome could be equipped with two, three or four sockets and round-bulb, all-frosted lamps which should be well shaded from the eyes of people sitting in a normal position about the table.

A house of the class here considered would not be provided with a superabundance of baseboard receptacles, and hence one or more of the sockets in the dome could conveniently be used for any one of the several cooking appliances. The dome circuits should be controlled by a wall switch, and the individual lamps by pull chain sockets.

In the dining room of the higher priced home, the lighting expert has a better opportunity to exercise his art. Here the semi-indirect bowl will usually meet with satisfaction. A 17-in. bowl, containing three or four sockets, with 25-watt or 40-watt lamps, gives considerable leeway, the size depending upon the color of the walls and the amount of illumination desired. Economically, it would be desirable to install a wall switch so arranged that one or all lamps could be turned on or off.

In the dining room, as in the living room, period furnishings and color schemes should be given thorough consideration. Semi-indirect bowls are made in various gently tinted colors, any one of which would tone down the light of the tungsten lamp to the soft, warm tones so much appreciated in the general lighting of a dining room. Bright or startling colors should be avoided, except on rare occasions. For instance, at Christmas time one might wish to decorate the dining room temporarily in red and green; at Hallowe'en time with black and yellow; St. Valentine's Day with pink, and so on. With the semi-indirect bowl or ceiling fixture one can easily produce almost any desired color scheme in lighting by the employment of various colored silks or papers.

Another attractive style of fixture is one with three or four lamps pointing up, and equipped with colored silk shades, cylindrical in shape, but smaller at the top than at the bottom, the colors selected depending on personal taste and the surroundings. This style of fixture should be equipped with round-bulb all-frosted lamps.

Ordinarily the delicate tints of rose, cream, yellow or amber, will be found to harmonize with the other decorations.

With these last two types of fixtures it would be found desirable to install a floor receptacle at about 1 ft. to the right of and 1 ft. out from a point beneath the center of the table, the idea being to extend the lamp cord over the edge of the table on the right hand of the person liable to do the serving, and to dodge the central pillar of the table if it has one. In addition to the floor outlet it might be found convenient to install a baseboard outlet near the serving table, in order that utensils could be used there when desired.

If the room contains a mantel and fireplace their charm would be enhanced by a pair of candle lamps. Thus, to equip one's home harmoniously, is to give a new charm and a new intimacy, for the secret of the attractive home lies in the graceful blending of lighting principles with the accessories.

It is with some hesitation that I approach the problem of illumination of dining-rooms of the palatial type. Here it is that we again come in contact directly with our esteemed friends the architect and the decorator. I am pleased to say that the meetings with these people in such places are more pleasant now than in times gone by.

In stately, dignified dining-rooms large chandeliers may be used with most beautiful effect; but they should be supplemented with multiple wall brackets and candelabra lamps. As most of these large rooms have period furnishings, we more and more realize the value of greater knowledge in period styles.

In this class of dining-room as in many others, frequently with the exception of a small lamp near the serving table, the other fixtures are seldom used, and tallow-candles furnish all the illumination desired. This effect is certainly very satisfying to the esthetic taste.

#### LIBRARY

Few of the smaller residences have what would be called a library, and in houses of the next grade the library and living-room are usually joined in one. Occasionally a room is used exclusively as a library, and by bad tradition it is usually in rather dark finish. Additional absorption of light is encountered when the walls are lined with bookcases filled with books. Here sufficient general illumination should be provided by ceiling fixtures to enable the titles of books to be clearly read. Wall brackets could hardly be recommended in a room of this character, since with these it is more difficult to light

properly the bookcases which lie nearly in the same plane with the brackets; and again, in locating the outlet for the bracket almost any place upon the wall is liable to interfere with the bookcase space. In this room proper reading lamps are of primary importance, and the same suggestions for reading lamps as have been made for reading lamps for the living-room previously described, would apply, not forgetting that a generous supply of floor or baseboard plugs is especially useful.

### MUSIC-ROOM

The average home does not have a room, as a rule, devoted exclusively to music, but occasionally such a room does exist. Brilliant lighting is not necessary here except when the room is used for other purposes. However, near the piano, which instrument usually gives the room its name, considerable localized light should be provided. This is best accomplished by means of a portable floor lamp equipped similarly to the reading lamp as previously described, supplied with energy from floor or base-board plug. As certain occasions may require the presence of several musicians or entertainers, a soft general illumination is often necessary. In all cases the lamps should be well shaded from the eyes of the guests. Wall brackets are objectionable from the fact that when lighted, they are eternally shining into people's eyes, much to their distress and discomfort.

The music-room is probably the only one in a residence where cove lighting could be considered. Before decision is made, however, due thought must be given not only to the client's pocket-book, but also to the possibilities of the lamps and trough being kept clean—which they generally are not.

In case use is made of the semi-indirect or chandelier source for general illumination, it must be carried high enough so as not to distract the attention, or in any way interfere with the field of view, and the lamps must be thoroughly shaded.

### DENS

From the character of "den" rooms, it would seem desirable to provide considerable general illumination, due to the fact that the walls are usually decorated to the ceiling with pennants, crossed swords, trophies, Indian relics, skulls and other articles of a rather

gloomy nature. It would be a pity for a guest to miss seeing any of these most interesting curios.

The finish and furnishings of these rooms being usually dark, more energy should be provided than in ordinary rooms of the same size. In case of a small room, a fairly deep semi-indirect bowl equipped with a 100-watt lamp, or, if the room is large, a shallow bowl containing three 40-watt lamps, would make a well lighted room.

Should localized light be required for a desk or table, I doubt if the type of lamp that would likely be selected to harmonize with surroundings would be suitable for either writing or reading, its only value being for decorative purposes, and it would be serviceable only when a little light is desired. The lamp cord should be connected to a baseboard receptacle and have chain pulls. A wall switch near the door should control the ceiling fixture.

#### SUN PARLORS OR CONSERVATORIES

These rooms being usually filled with plants and flowers, some of which grow to the ceiling, soft, general illumination is required, and the semi-indirect bowl will produce a beautiful effect. In addition to the general illumination a table lamp will prove very serviceable.

#### KITCHENS AND PANTRIES

These are the working portions of the house and should receive careful consideration. In the small kitchen a 60-watt lamp equipped with a shallow prismatic reflector, located well up in the center of the room, will give the light required in all parts. In the small pantry one 25-watt or 40-watt lamp, similarly equipped over the working table, would provide ample light.

In the large kitchens, lamps should be installed at one or more points, as the arrangement of the working space requires, such as the stove, the sink, and very likely a working table. In case of a hooded range, one or two lamps should be placed under the hood.

A ceiling lamp should be provided for general illumination, under control of a wall switch conveniently located; in some cases it may be found convenient to control this lamp also from the second floor.

All kitchens should be equipped with receptacles for flatirons and other appliances. Butlers' pantries, where glasses and dishes are washed and stored, usually require two ceiling fixtures, one over the

sink and another to illuminate the shelves. Twenty-five watt lamps, with enclosing shades, furnish the proper equipment.

### HALLS

In most of the new residences the halls are almost as much a *living* part of the house as are some of the other rooms. In nine out of ten of the houses a person in the living- or dining-room, can see into the hall. With this arrangement the lamps should be carefully shaded so that the glare may not be offensive to persons in the other rooms. This remark applies in the case of direct lighting by lantern or small fixture.

A semi-indirect unit makes a pleasing hall light source. The bowl selected should be of the deep type and not very large. If the hall is long, and the back part is left in comparative darkness, it may be necessary to supplement the principal fixture with wall brackets. In case of an exceptionally low ceiling, wall brackets are to be preferred, the lighting being balanced by means of one or two on each side wall, depending upon the length of the space. The fixture, or one of the wall brackets, should be controlled by a switch near the front door and also from the second floor.

The second floor halls generally do not require as much light as do the lower halls. If the ceilings are low, say 8 or 9 feet, a hemisphere or squat ball makes a good unit. If there is only one lamp, it should be placed near the top of the stairs. If the hall is large, another should be installed in the other part. Both of these should be controlled by wall switches and the one most used should be controlled also from below.

Wall brackets if used at all in halls or passageways should be installed rather high, because there is danger of persons running into them in the dark.

Back halls and passageways require very little light. The location of fixture should be such that the lamps will thoroughly light the stairways.

In the halls of the more imposing character, fixtures of special design will be necessary. These should give a well diffused light and fairly soft shadows. Should the upper part of the room be decorated with special architectural features, due consideration should be given this fact, and arrangements should be made to give them proper significance. Not infrequently there are paintings, and these also may require special treatment, by lamps placed to illuminate them directly.

## BEDROOMS

In the bedrooms the handiwork of the feminine sex will be everywhere in evidence. Probably in no other part of the house will she be as much concerned as here, she has decided upon the location of the dressing table and planned to have the various rooms decorated in appropriate colors. It is necessary for the engineer to know what these colors are to be in order that the shades selected may be of a tint to match. I mention these frivolous matters first, not because of their importance, but because in the lighting of the home similar matters are first brought to the attention of the illuminating engineer by the lady of the house, and if he fails to gain her favor he may as well stop before beginning.

It is a recognized fact that the bedroom suffers more from misplaced fixtures than from insufficient light, for the amount of light required is not large in rooms of medium finish.

Now, assuming that the architect has provided space enough between the windows for a dressing table, and then a little more, one can recommend a pair of swing-arm wall brackets, one on either side of the mirror, as the most satisfactory lighting equipment. If the cheval mirror or a mirrored door is among the articles of furniture, it could be equipped in a similar manner. When it is definitely known where the other articles of furniture are to be placed, one can easily provide lighting for the remainder of the room.

Wall brackets, properly shaded, are to be preferred for bedroom lighting. For those who follow the practice of reading in bed, an additional small reading lamp can be installed for use beside the bed. This lamp should be controlled by a pull chain or pendant switch, easily reached from the bed.

There is no serious objection to the use of a ceiling lamp in a bedroom, but it should be resorted to only in cases where extreme economy must be observed.

At least one lamp in the room should be controlled from a switch beside the door.

## BATHROOMS

There is little to be said about bathrooms. The best method is to install two wall brackets about on a level with a person's face, one on each side of the mirror. These will not only give ample general illumination in the largest of bathrooms, but are most suitable for shaving.

In very small rooms one center ceiling lamp does very well when placed high. A switch should be placed near the door.

In this room should be placed a receptacle for a water heater.

### CELLARS AND LAUNDRIES

Cellars usually require only a very moderate amount of lighting. Use could be made of one 25-watt tungsten lamp near the foot of the stairs and another in front of the heater. If the cellar is sub-divided, other lamps placed in the dark portions will be helpful. The lamp near the foot of the stairs and the other one near the heater should be controlled by a switch at the top of the stairs.

There is seldom much work to be performed in the laundry after dark, but in city houses, the laundries are often so located that no daylight enters at all. Here there should be one lamp over the tubs, one over the ironing table, and one for general illumination. The lamp over the table and tubs should be equipped with steel porcelain enamel reflectors, and controlled by key sockets. The center lamp should be controlled by a switch located near the door. Receptacles should be installed in the laundry for washing machines and flat irons.

### PORCHES

The porch does not require any high intensity of illumination, for we would refrain from making it look like a store front. The purpose for which a porch lamp is used is welcoming the arriving and speeding and the departing guests, illuminating the steps and enabling the people in the house to scrutinize a caller.

If the front porch lamp has any value for the last-mentioned reason, then why not a back porch lamp? Its advantage would at once be appreciated by the average woman in the home, when the back door bell rings, perhaps late in the evening, or when she is alone in the house. A 25-watt lamp in an enclosing ball near the ceiling of the porch and controlled by a switch inside the door, is all that is required.

### GENERAL REMARKS

I am not in favor of elaborate massive fixtures anywhere in the ordinary house. The more simple and unobtrusive ones are much to be preferred. In selecting fixtures for the whole house, the nearer they match each other in design the better. The metal parts should

particularly be of the same design and finish, although the glassware or shades can be different in shape and color.

In other words, in the smaller residences all the fixtures should be as nearly the same style as possible, or the house will look like a second-hand fixture establishment. In large houses, the type of decoration is the controlling element.

In conclusion, I want to call attention to the fact that central station managers are beginning to realize the importance of increasing the residence load. The great variety of house wiring campaigns now under way certainly emphasize this fact and great effort is being made to equip old houses for electric service.

In the territory of the Edison Electric Illuminating Company of Boston alone, there were many thousands of unwired houses before the house wiring campaign was started, and at the end of three years about 4000 of these houses had been wired on the "Easy Payment Plan" with an approximate annual income of \$100,000—an average of \$25 per year, per customer. This means an addition to the lighting load of about 4000 kw. which load, coming as it does on a late peak, is very desirable, a fact that is being appreciated more and more.





## THE LIGHTING OF STREETS—PART I

BY PRESTON S. MILLAR

This lecture is to be considered as complementary to that of Mr. Lacombe which is to follow. The two are intended to embrace the entire subject of street lighting. The division between the two is arbitrary and of course cannot be absolute.

### HISTORICAL

Within the limitations of time imposed it is not desirable to dwell upon the historical aspects of the subject. The evolution of street lighting from the torch bearing stage through the period of candle and oil lamps, maintained individually by citizens,\* up to the beginning of community or municipal maintenance, has little practical bearing.

The modern history of street lighting begins with the invention of illuminating gas and assumes its second interesting phase with the development of the direct-current series carbon arc lamp. Following these two stages of progress, the historical aspects of street lighting naturally ramify into the history of street illuminants, of street lamp mountings, of street lamp equipments and accessories and of the development of ideas of street lighting principles. These several phases of the subject are treated under their respective headings in either this lecture or in Mr. Lacombe's lecture.

### PURPOSES

The earliest street lighting was adopted as a measure of protection for the wayfarer against the criminally inclined. At first this purpose was served partially by the carrying of torches.

\* Some milestones in the historical progress of street lighting are as follows:

1558—Paris the first modern city to attempt civic street lighting. Inhabitants ordered to hang lighted candle lanterns in front of houses.

1766—Pitch or resin bowls substituted for candle lanterns.

1809—First street lighting by illuminating gas in London.

1821—Illuminating gas used in Baltimore for street lighting.

1884—Arc lamps used in Philadelphia for street lighting.

1896—Gas mantle lamps first used in this country for street lighting.

Then the lamps were placed permanently along the way, affording better protection and also marking the route. From this stage street lighting was evolved into a means of safeguarding traffic against collision and of revealing obstructions or holes in the roadway. More recently it has been developed into an ornate system which not only accomplishes these purposes but also promotes commerce and embellishes the highway both by its own artistic qualities and by the lighting effects which it produces.

Modern street lighting serves the combined purposes which have been named, these being fundamental perhaps in the order in which they are mentioned. The protective element, however, is sometimes taken for granted, and most, if not all, attention is directed to the last purposes named. All street lighting ought to serve these several purposes and the importance of each purpose in a particular installation must depend upon the local conditions, principal factors among which are traffic density, real estate development and criminal hazard. In portions of cities in which evil resorts exist, the police protection factor is of first importance. In interurban highways the marking of the way and provision against collision are essential. The dignified, high-class avenue must be so lighted as to reveal its character by exhibiting to advantage the architectural features of the buildings. For police purposes the lighting should be designed primarily to reveal large objects on the street and sidewalk.

To serve the purposes of the automobilist the same requirement exists, and in addition raised places or depressions in the roadway should be revealed, and the curb or limitations of the driveway should be perceptible. His is the most difficult requirement to meet because of the high rate of speed at which he travels. Safety requires that he must be able to detect the presence of objects in a single glance.

The pedestrian requires somewhat the same lighting design, though he is especially concerned in having inequalities in the sidewalk revealed. In the important streets he should be able to distinguish faces of passers-by.

From the point of view of æsthetics the fundamentals of design in all visible portions of the lighting system should be observed. This applies especially to posts, fixtures and glassware. The incongruous should be absent; nor should the general effect of the street be neglected. The fixtures should be of pleasing design in themselves and suitable to their surroundings. They should be installed at such intervals and in such locations as to enhance the attractiveness of the street by day and by night.

Minor requirements of street lighting present themselves. For example, one may wish to observe the time indication of his watch, or to read an address on a card, or to find an article which he has dropped, or to read a number on a house front. All such requirements are distinctly minor and should not have an important place in a discussion of this kind. Many of them can be met by moving near to a street lamp; others occur so infrequently as not to demand much consideration. In general, lighting which serves the major purposes outlined above serves also these minor purposes as well as they can be served with a given expenditure for lighting.

All of the foregoing may be summed up in a statement of the purposes to be served by street illumination put forward by the Street Lighting Committee of the National Electric Light Association in 1914 as follows:<sup>1</sup>

1. Discernment of large objects in the street and upon the sidewalk.
2. Discernment of surface irregularities on the street and on the sidewalk.
3. Good general appearance of the lighted street.

In studying the street lighting requirements for a particular locality, much time and thought profitably may be devoted to defining for that locality the principal purposes of the street lighting. With these purposes clearly in mind, best efforts are more likely to be made to design the installation in conformity with the requirements. Most serious mistakes in the design of street lighting have occurred because those responsible have failed properly to analyze the purposes to be served by the lighting and have proceeded in design without sufficient thought or according to preconceived ideas of the requirements of good street lighting. It is almost as unreasonable to design street lighting without reference to the local requirements as it is to design interior illumination without reference to the character and decorations of the room.

#### EXTENT AND SCOPE

Street lighting is regarded as one of the indispensable functions of municipal government. As a rule in this country it is rendered by a private corporation under contract with the municipality. Cities, towns, and even the smallest villages are lighted very generally. It has been stated that the lighted streets of New York City alone, if placed end to end, would form a single lighted highway extending from New York to Reno, Nevada.

It is the usual practice to adjust the intensity of street lighting to the real estate and traffic conditions of streets, lighting the important streets more brilliantly than the secondary streets. Appropriations for street lighting purposes are often somewhat inadequate with the result that all classes of streets are not as well lighted as the engineers in charge would like to have them.

In recent years the great growth of automobile traffic has complicated the street lighting situation in a number of ways—for one thing the use on the automobile of too brilliant lamps at night has introduced a serious problem. Where street lighting is so inadequate as to make their use important, automobile lamps for lighting the roadway safeguard the automobilist but introduce a large measure of annoyance and some danger for other travelers. Where street lighting is reasonably adequate within municipal limits, it is entirely feasible to abolish the use of head-lamps, as is demonstrated by the experience of some years in New York City. If instead of seeking to eliminate the difficulty solely by limiting the light from head-lamps municipal authorities would see to it that the street lighting is adequate, the whole problem could be dismissed by prohibiting the use of head-lamps within the city limits.

The advances of the last ten years in efficiency of light production have led to considerable improvement in street lighting. Not all of these advances have been put into increased lighting; part have been realized by municipalities in reduced lighting costs. Thus the great opportunities offered by the new illuminants for better street lighting have not been grasped in their entirety, though very large improvement has resulted.

In the last two or three years marked impetus has been given to the lighting of village roads and of rural highways.<sup>2</sup> Counties, towns and villages are awaking to the value of such highway lighting. Street lighting growth is reactive. If a street is lighted because there is traffic requirement for lighting, the result is increased traffic, which in turn brings the demand for better street lighting.

The tendency of municipalities to appropriate inadequate sums for street lighting has offered an opportunity which the American business man has not been slow to grasp, with the result that there has entered into American practice the merchants' display lighting system, the so-called "white way" lighting, whereby a given street through the activity of a merchants' association is much more brilliantly lighted than adjacent streets. This is considered good advertising in that it attracts people to the locality. Installations

of this sort are generally of distinctive design; many of the earlier ones were of the incandescent lamp cluster type;<sup>3</sup> some consisted of arches across the street; others of festoons of lamps mounted over the curbs. The more recent installations have consisted of a post and a single ornate lighting unit enclosing either an arc<sup>4</sup> or an incandescent lamp.

When well organized and operated under the strict supervision of a strong merchants' association or of the municipality, this sporadic street lighting has been successful in setting a new and higher intensity for street lighting, tending to advance the standard everywhere. When not controlled, it has sometimes led to isolated and ill-considered instances of merchants' lighting which has resulted in a hodge-podge, often three or four different lighting units being installed on a single block, some lighted at night and others unlighted.

In a few instances municipalities have installed special high intensity street lighting systems at a greater expense than would ordinarily have been incurred for the street selected, the city having in mind something of the same considerations as have actuated merchants' associations, namely the advertising of the locality in order to bring traffic to it.

Prevailing intensities in street lighting practice in a measure are dependent upon the extent and intensity of private lighting with which they are brought into frequent comparison. In a city where the private lighting is highly developed, the general level of street lighting intensities is likely to be higher than in other cities. In passing it may be noted that the converse is also true, and that the introduction of higher intensities in street lighting tends to increase the intensities of private lighting with which it is contrasted.

The general practice is to light street lamps shortly before dark and to allow them to continue in service until after daybreak. The 4000-hour year in this latitude is standard. No self-respecting city continues the archaic moonlight schedule whereby street lamps are not lighted when the almanac states that the moon should be shining. A more reasonable modification of lighting practice, applicable to merchants' lighting rather than to civic lighting, is the reduction of the amount of street lighting after the midnight hour, as for example, the extinguishing of a certain percentage of the lamps.

Like many other municipal enterprises, street lighting serves the entire populace and is a matter for community interest. More

than most such municipal activities, its status is apparent to the citizen and to the visitor. A city is likely to be judged by its municipal undertakings, and the most casual observer takes cognizance of the condition of the street lighting.

“A city is judged by impressions. It may have the finest climate in the world; it may be fortunately situated near rivers and railways; it may have every natural advantage that a business man may desire. Yet if it be unattractive, dirty and gloomy, its development will be slow. When it does develop, the first impetus will be given by changing its appearance for the better; and in that change street lighting will play an important part.”<sup>5</sup>

Something of this view is manifesting itself in many cities of the country, and the newer installations are reflecting in their enhanced attractiveness and effectiveness the municipal pride which underlies design.

The cost of civic street lighting per capita generally ranges from 60 cents to \$1.20. It amounts to perhaps, from 2 to 3 per cent. of the total municipal expenditure. Its value must be taken to include not alone the safety features which are its primary purpose, but as well a part of the city growth and the promotion of the industry and the welfare of its citizens. It may be claimed also that the large expenditures for highway construction are rendered of greater utility by street lighting, and that to a degree the street lighting must be credited with the promotion of the enormous traffic which these highways bear. To quote a recent expression:

“It is earnestly believed that when the economic value of a system of street lighting is compared with other public works, such as schools, bridges, police force, fire department, etc., the price required to be paid for the protection of the life and limb of the entire citizenry of the inhabitants; the protection of our wives and daughters from crime and annoyance; the protection of our property from burglary by supplementing the police force by adequately lighted streets; the various conveniences to the public, secured by sufficient illumination on the streets, and the advertising and æsthetic values of adequate street lighting to the city at large, and to the individuals—the cost of an adequate street-lighting system will be found to be insignificant compared to the value received, and the expenditure well worth while.”<sup>6</sup>

#### ILLUMINANTS

*Recent History.*—The earliest development of importance to this discussion was that of the open carbon arc lamp and series direct

current lighting systems. The early records of street lighting in this country show a number of competing companies manufacturing equipment for such systems. They became recognized standard street lighting systems and continued as such until the development of the enclosed carbon arc lamp in 1894.<sup>7</sup> The open carbon arc lamp in this country, generally speaking, did not attain to the development which it received abroad. It is understood that the carbon electrodes produced in America were inferior to those later employed in Europe. The superiority of the electrodes available and the lower prevailing cost of labor in Europe led to the continuation of the open carbon arc lighting system for years after its decline began in this country.

The enclosed carbon arc lamp by reason of its relatively long electrode life and low maintenance cost received in this country a measure of development which it could not experience abroad. It possessed other advantages over the open carbon arc lamp which aided its success, including a better light distribution characteristic and a greater steadiness of light. In the course of the decade succeeding its invention, the enclosed carbon arc lamp became the standard street lighting lamp in this country.

As subsidiary to the arc lamp, small illuminants were used in the lighting of streets of minor importance. These were the gas mantle lamp, the gasoline lamp and the series carbon incandescent lamp.

The period of modern street lighting illuminants was ushered in by the development of the metallic electrode lamp in 1904.<sup>8</sup> This lamp, known as the magnetite lamp, and the metallic flame arc lamp and also as the luminous arc lamp, attained great eminence in street lighting practice in this country during the decade following its invention.

Within this same decade the flaming arc lamp was the subject of much experimental and development work on the part both of arc lamp manufacturers and of electrode makers. The same difficulty of high maintenance costs in this country placed it beyond practicability to utilize the short-life flaming arc lamps of European development. As in the case of the carbon arc lamp the difficulty was reduced by enclosing the arc and securing a much longer electrode life. For a time the enclosed flame arc lamp with long life electrodes bade fair to become a real factor in the street lighting situation in this country. Several important extensive installations were made with more or less satisfactory results. The development of the gas-filled tungsten lamp known as the "Mazda C" lamp, in



1914,<sup>9</sup> however, introduced competition which the flame arc lamps of present types have not been able to meet except in special cases.

The Mazda C lamp superseded a number of illuminants in the street lighting field. It hastened the displacement of open and enclosed carbon arc lamps which were still in the field. Its availability in small sizes resulted in its substitution very generally for the gas and gasoline mantle lamps which had very largely claimed the secondary streets for their own, and of course it displaced the inefficient carbon series lamps wherever they were in service.

The development of street lighting practice is so largely involved with the development of street illuminants that this brief account of the development of the latter serves to recall the history of street lighting as a whole. The development of other phases of street lighting practice has perhaps lacked the definite steps of advance which are apparent in the record of the illuminants employed, but the progress has been none the less real on that account.

*Modern Lamps.*—As electric and gas illuminants are the subjects of other lectures, their qualities need not be discussed in detail in this connection. Street lighting lamps in this country are as follows:

Gas filled tungsten lamps (Mazda C).

Arc lamps (principally magnetite lamps).

Low pressure gas and gasoline mantle lamps.

The incandescent lamps are usually of the series type, though in some cities, notably New York City, multiple lamps are employed. American selection of illuminants differs somewhat from that in European countries due to the higher labor costs and greater distances prevailing here. Thus it may prove economical for us to sacrifice something of efficiency in order to secure lower maintenance cost, while in Europe the maintenance cost is not so large a factor in the total. This in part accounts for the fact that flaming arc lamps and pressed gas lamps have not come into use largely in this country as abroad. On the contrary, the magnetite lamp has been used largely here and hardly at all abroad.

Through the courtesy of the Lamp Committee of the Association of Edison Illuminating Companies, the accompanying table of data on electric street lamps is available.

In this connection Fig. 1 will be of interest. This shows the lumens produced, the watts, and by reference to the diagonal lines, the efficiency of the principal electric street lamps. The lumens per watt output of street lamps is by no means a final measure of

TABLE I.—RELATIVE LIGHT PRODUCING EFFICIENCIES OF MAZDA C, FLAMING ARC AND MAGNETITE LAMPS

Mazda C lamps								
Description			Bare lamp			Equipped for service assuming 25 per cent. absorption in accessory		
			Total lumens	Average watts	Lumens per watt	Total lumens	Average watts	Lumens per watt
6.6-amp., "60-cp.".....			600	46.9	12.8	450	46.9	9.6
6.6-amp., "100-cp.".....			1,000	71.9	13.97	750	71.9	10.4
6.6-amp., "250-cp.".....			2,500	155.0	16.12	1,875	155.0	12.5
6.6-amp., "400-cp.".....			4,000	245.0	16.32	3,000	245.0	12.2
6.6-amp., "600-cp.".....			6,000	367.0	16.32	4,500	367.0	12.3
20-amp., "600-cp." (compensator)..			6,000	310.0	19.3	4,500	310.0	14.5
20-amp., "1000-cp." (compensator).			10,000	518.0	19.3	7,500	518.0	14.5
110-volt, "75-watts".....			.....	.....	.....	.....	.....	.....
110-volt, "200-watts".....			2,795	200.0	13.97	2,098	200.0	10.5
110-volt, "400-watts".....			6,130	400.0	15.33	4,600	400.0	11.5
110-volt, "750-watts".....			12,740	750.0	16.99	9,550	750.0	12.7
110-volt, "1000-watts".....			17,960	1,000.0	17.96	13,480	1,000.0	13.5

Magnetite lamps								
Description			Bare lamp			Equipped for service		
A-m-peres	Electrode	Globe	Total lumens	Average watts	Lumens per watt	Total lumens	Average watts	Lumens per watt
4	Standard.....	Clear	.....	.....	.....	2,991	310	9.65
4	High efficiency....	Clear	.....	.....	.....	4,649	323	14.4
5	Standard.....	Clear	.....	.....	.....	5,768	390	14.8
5	High efficiency....	Clear	.....	.....	.....	7,655	371	20.6
6.6	Standard.....	Clear	.....	.....	.....	8,708	511	17.0
A.C. enclosed flame arc lamps								
7.5	(Yellow).....	Clear	.....	.....	.....	8,557	480	17.8

the relative economy of the several types, but it is one important factor entering into the problem.

Fig. 2. shows change in illuminating power and output or efficiency with change in electrical values for the several types of modern street lamps.

All lamps used for street lighting are variable as to candle-power. There are inherent initial variations. Other variations are due to operating irregularities, including those of supply and of maintenance. Arc and gas lamps are subject to additional variations involved in adjustment, and irregularities in the light-giving elements. Most of these variations, however, do not detract materially

from the utility of the lamps in service. It is important to note their existence to avoid misapprehensions affecting engineering practice or specifications rather than to include them as factors affecting the value of the lighting service to the public.

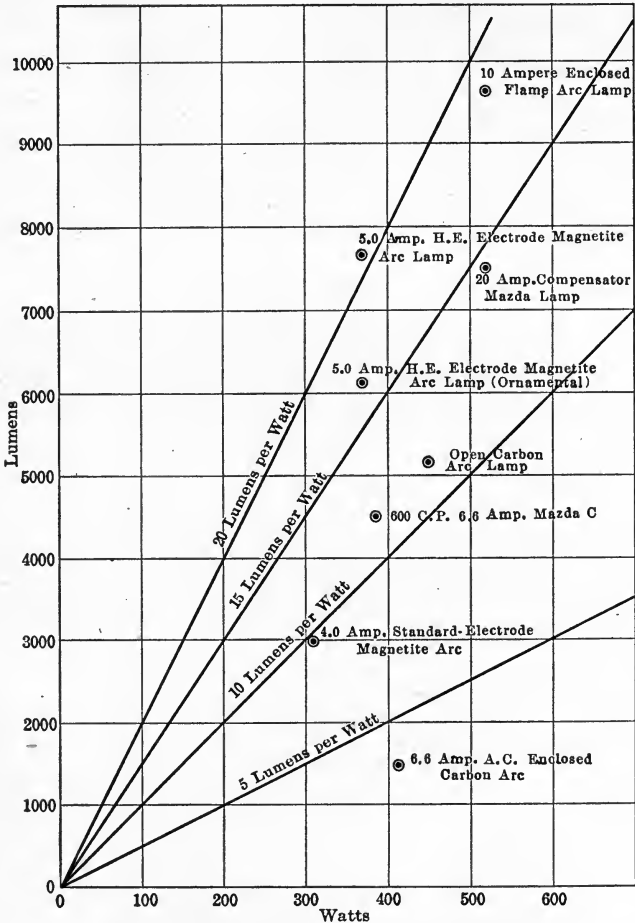

Fig. 1.—Typical initial values of electric illuminants.

### ACCESSORIES

Since lighting accessories are covered thoroughly in another lecture, it is the purpose here to touch upon them but briefly. In street lighting the lamp accessory serves to protect the lamp, to redirect the light, to reduce the brightness, and to improve

the appearance of the unit. Sometimes all of these purposes are accomplished; again, only one or two of them may be served. While many varieties of accessories are available on the market, yet it is fair to say that the development along this line is far from complete. The characteristics which are regarded as desirable in all lamp accessories intended to serve these purposes include: Simplicity, sturdiness, cleanliness, low cost, and low light absorption. Apparently the advantages of securing the best balance among these desirable qualities is not generally appreciated, nor are accessories always selected upon the basis of data concerning their various qualities.

In the selection of accessories, after the generally desirable qualities have been sought, the question of a desirable light-direct-

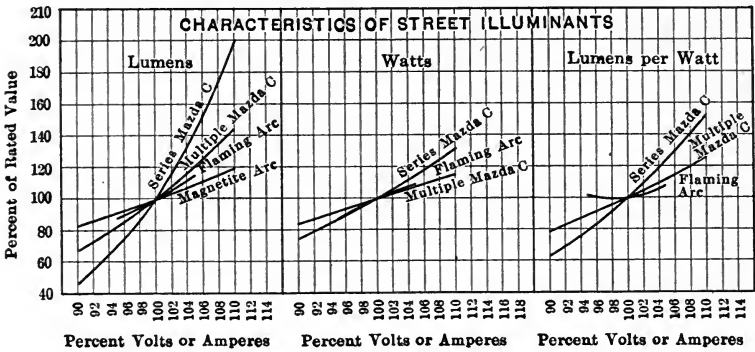

Fig. 2.—Variation of input and output with change in voltage.

ing characteristic remains. This should not be considered to the exclusion of other qualities; but, other things being equal, a generally desirable form for various classes of streets may be indicated. Thus in the lighting of residence streets and of highways, little or no light is desired in the upper hemisphere, and a form of distribution curve similar to that provided by the pendant magnetite lamp or by the tungsten-filament or Mazda lamp with reflector or refractor may be acceptable. On the other hand, in the illumination of principal avenues and business streets of a city, some light above the horizontal is essential to the good appearance of the street. Here some form of diffusing globe becomes desirable.

The absorption of light in fixtures and accessories usually is an important factor in reducing efficiency. Much may be accomplished through skilful design in minimizing this loss. Containers which

completely enclose the light source are of course likely to occasion a greater absorption loss than are reflectors which receive only a portion of the total flux without subjecting the remainder of the flux to absorption. In considering loss due to absorption it is well to be more tolerant of absorption which results in great reduction of brightness and which effects desirable re-direction of the light flux. Absorption which results in neither desirable re-direction nor sufficient reduction in brightness is difficult to excuse. Absorption involved in either re-direction or brightness reduction without accomplishing the other desirable purpose, may or may not be overlooked, depending upon local conditions. The best design of accessories should accomplish both objects to a reasonably satisfactory degree.

Some statistics of absorption of light in accessories for street lighting are presented in Table II. This indicates for reflectors which intercept only a part of the light, absorptions ranging from 12 to 32 per cent. For housings with enclosing globes the absorptions range from 18 to 39 per cent.

TABLE II.—ABSORPTION OF LIGHT IN ACCESSORIES  
(Mazda Lamps)

Lamp	Accessory	Loss of light, per cent.	Remarks
	<i>Reflectors.</i>		
500-watt	Steel enameled reflector—shallow curve.....	29	
250-watt	Steel enameled reflector—shallow curve.....	32	
25-250 watt	Radial wave reflector.....	12-21	Varying with size of reflector and location of lamp filament.
	<i>Enclosing Units.....</i>	23-40	Depending upon intensity of globe and size of housing.
	Concentric reflector and refractor...	36	
400-cp.	20-in. concentric reflector and diffusing globe.....	34	
400-cp.	18-in. radial wave reflector and diffusing globe.....	32	
250-cp.	Radial wave reflector and diffusing globe.....	39	
	Refractor units.....	31-39	
	Ornamental upright fixtures—diffusing globes.....	18-27	
	<i>Enclosing Accessories alone (without fixtures).</i>		
	Diffusing globes with slight blue tint.	Approx. 45	
	White diffusing glass.....	8-29	
	C. R. I. glass.....	5- 8	
	Clear glass.....	Approx. 4	

In the design of street lighting accessories in general considerable progress has been made during the past few years. This has consisted principally in small improvements which have entered into general practice. The more general use of diffusing globes and of the better class of reflectors is a matter of common knowledge and represents the principal advance in accessories.

In recent years there have been several attempts at radical revision of accessory design to secure a particular light distribution. Among these may be mentioned an asymmetrical prismatic device having reflecting prisms on one side and the usual combination of diffusing ribbings and redirecting prisms on the other side. This was designed to direct upon the street a portion of the flux which otherwise would fall upon building fronts or fields along the street. Another device is the two-way (or four-way) half parabola reflector. This is designed to direct upon the street most of the light which otherwise would be delivered above the horizontal and much of the light which without it would fall upon buildings or fields along the street. A third design represents an endeavor to avoid glare. It consists of a prismatic hood with an opal envelope. Its candle-power distribution is symmetrical and for successful application it requires to be installed either at relatively short intervals or at relatively great height.

The most recent development along this line is a special prismatic refractor,<sup>10</sup> which differs from the usual prismatic arrangement in that the diffusing ribbings and the directing prisms are turned inward, the outer exposed surfaces consisting of smooth glass. A typical candle-power distribution curve is shown elsewhere in Fig. 4. The refractor is entering into practice more largely than have any of the other light-directing devices just described. A recent modification of the refractor is known as the band refractor, differing from the ordinary refractor in that the lower part of the bowl is missing. The downward light from the source is therefore allowed to escape without redirection or absorption. Candle-power distribution curve is shown elsewhere in Fig. 6.

Diffusing globes of alabaster, opal and cased glass are available, offering a variety of sizes and shapes, as well as a wide range of diffusion and absorption. Also the use of segmented diffusing globes is growing. It is therefore possible to choose for any lamp fixture and post a globe which will possess precisely the qualities needed to produce the desired light effects, and to comply with the artistic requirements of the installation.

## CALCULATIONS OF STREET ILLUMINATION

The computation of total or zonal light flux from candle-power distribution curves need not be considered in this connection, as it is treated in another lecture. While in the calculation of illumination on the street the same principles are involved as in other illumination computations, yet the applications are somewhat different because the surface illuminated is a long, narrow strip.\* While reflecting surfaces such as buildings play an important part in street illumination, yet the light which they return to the street surface is usually not large and it may be ignored in these computations. This simplifies the problem materially.

In order to carry out some simple studies of light delivered upon the street surface, four characteristics of vertical candle-power distribution are selected as follows: These are typical of:

Magnetite lamp with band refractor.

Magnetite lamp, pendant type, clear globe and small internal reflector.

Mazda C lamp in a bowl refractor.

Mazda C lamp in a particular fixture with diffusing globe.

These four distribution curves adjusted to the same total flux appear in Figs. 3, 4, 5 and 6. They represent the range of practical distribution characteristics encountered in street-lighting practice at the present time. It is desired to emphasize the shape of distribution curve. It is the purpose to deal with the characteristics of distribution rather than to undertake a comparison of illuminants.

In order to afford a better idea of the candle-power distribution represented by the curves, there are presented solids of revolution of the candle-power distribution curves for three of the characteristics selected. These solids (Fig. 7) therefore represent the mean distribution of candle-power. It is assumed that the lamps are mounted 22 feet over one-curb of a level and straight street, of which the roadway is 50 feet wide and each sidewalk is 15 feet wide. The candle-power effective upon the street between building lines is represented by the white portion of the distribution models.

The computation of flux delivered upon the street consists in ascertaining what portion of the total light is represented by the white part of the solid. It is apparent that the procedure to be followed consists in determining the zonal flux values for the illuminant and in ascertaining the portion of the flux in each zone

\* This is complicated when a lamp is mounted at street intersections.



Fig. 7.—Solids representing distribution of candle-power corresponding respectively with Figs. 4, 5, and 6.

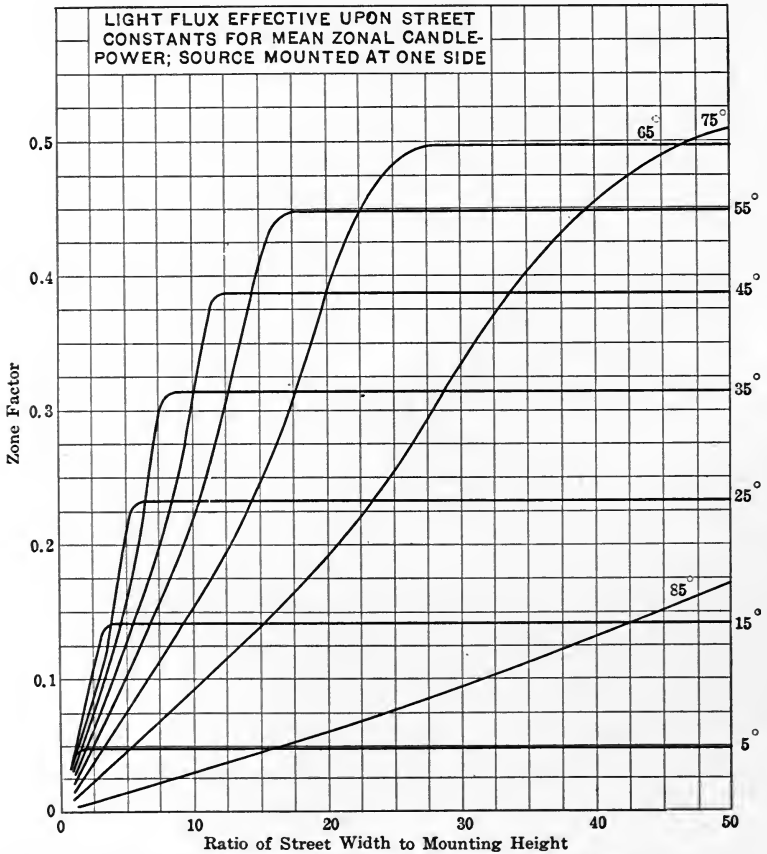

Fig. 8.—Chart for calculation of light flux delivered upon street surface directly from lamps. (Facing page 428.)





which falls within the street boundaries. The solid of revolution of the candle-power distribution curve of the light source may be divided into zones assumed as equivalent to zones of spheres. That portion of each such zone which lies between a plane perpendicular to the street and parallel to the building line and a plane passing through the opposite boundary of the illuminated surfaces, supplies a basis for the computation of zonal constants by means of which the proportion of flux delivered upon a street in

Fig. 3.

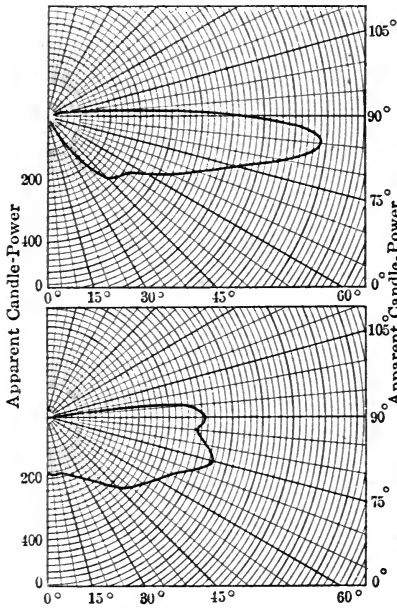

Fig. 5.

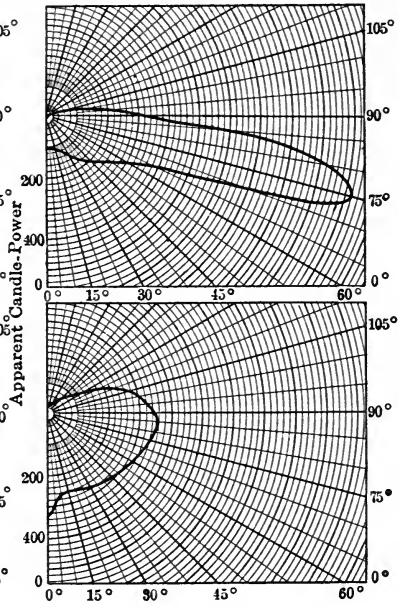

Fig. 4.

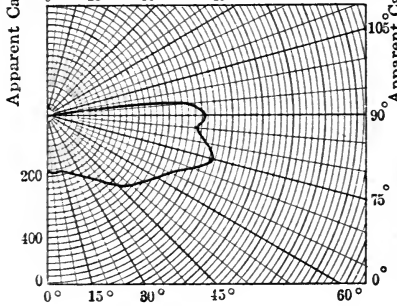
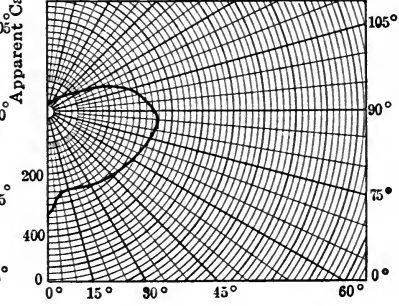

Fig. 6.



Figs. 3, 4, 5 and 6.—Vertical candle-power distribution characteristics.

each zone may be determined. These constants depend upon the ratio of street width to mounting height.

From such constants the chart in Fig. 8 has been prepared.\*

To illustrate the application of this chart, let us take the assumed standard conditions and the curve of the complete unit in Fig. 4. The following table shows computations of the per cent. of the total flux in each zone delivered upon the street, employing the mean zonal candle-power. The flux upon the sidewalk on one side of the

\* Studies of light flux delivered upon the street were presented before the Illuminating Engineering Society in 1910.<sup>11</sup> Improved methods of calculating these values have been developed by Mr. E. Peterson who has prepared the chart in Fig. 8, and to whom the lecturer is indebted for permission to use it.

lamp and that upon the driveway plus the sidewalk on the other side have to be added together to obtain the total light flux distributed upon the street.

#### FLUX ON STREET

Candle-power Distribution as in Fig. 4. Mount 22 ft., Street Width 50 ft., Sidewalks 15 ft. Source over One Curb.

Mid-zone Angle	Mean zonal candle-power	Driveway + one sidewalk		One Sidewalk	
		$R = \frac{65}{22} = 2.95$		$R = \frac{15}{22} = 0.68$	
		K	Lumens	K	Lumens
5°	105	0.047	4.9	0.047	4.9
15	115	0.141	16.2	0.141	16.2
25	130	0.232	30.1	0.232	30.1
35	170	0.314	53.4	0.263	44.7
45	210	0.387	81.3	0.178	37.4
55	270	0.449	121.2	0.141	38.1
65	480	0.496	238.0	0.105	50.4
75	930	0.328	305.0	0.063	58.6
85	620	0.092	57.0	0.020	12.4
			907.1		292.8

Flux effective on street..... 1200 lumens.

Total flux produced by unit..... 2991 lumens.

Proportion delivered upon street..... 40 per cent.

This method of calculating light flux delivered upon the street is employed elsewhere in this lecture in studies of effect upon delivered flux of changes in location of street lamps.

The characteristic of distribution of horizontal and vertical illumination intensities for each of the four illuminants which have been chosen is indicated in Figs. 9 and 10. These show intensities computed along the street in line with a single lamp. The curves of horizontal illumination show maximum values near the lamp to be greatest in the case of the diffusing globe equipment.

#### DISCERNMENT UNDER STREET ILLUMINATION

*Visual Characteristics.*—The theoretical aspects of vision under street-lighting conditions are covered in another lecture of this course. It may be well, however, to indicate briefly in this connection the salient features which have a direct bearing upon our problem. The

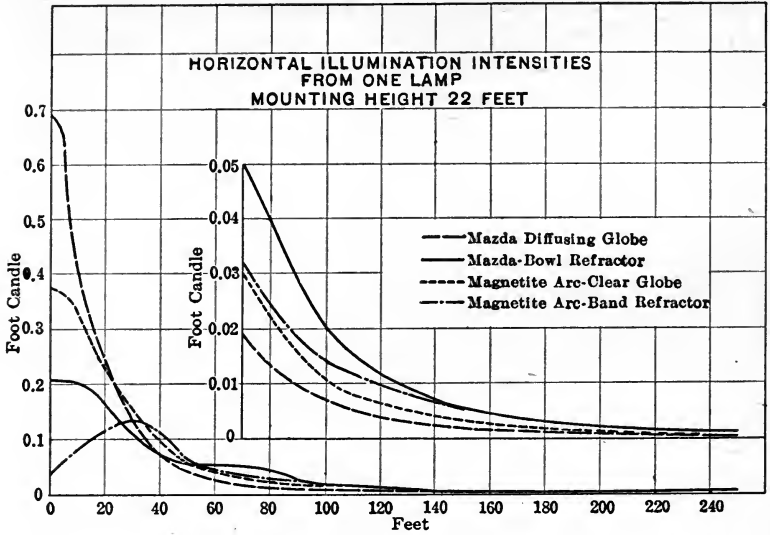

Fig. 9.—Variation of illumination with distance.

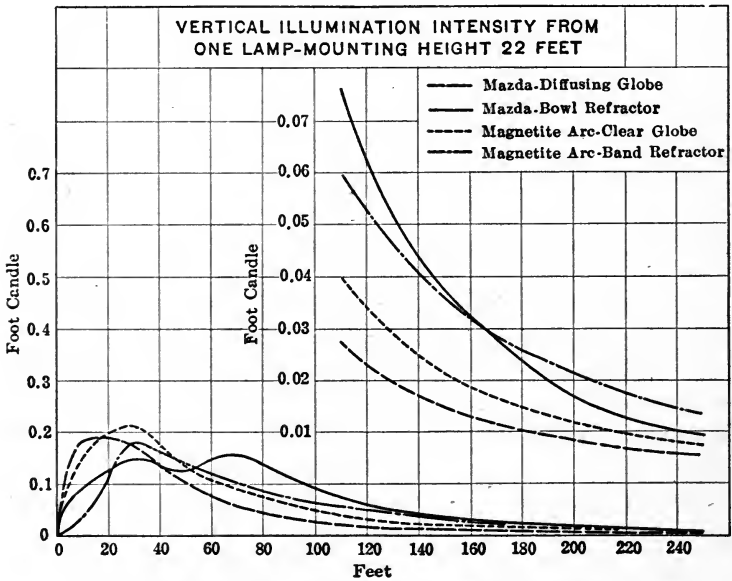

Fig. 10.—Variation of illumination with distance.

von Kries rod and cone theory of vision now generally accepted allots to the retinal rods the process of vision at very low intensity. The rods are thinly interspersed among the cones in the central or foveal portion of the retina of the eye and are more thickly clustered about the peripheral portions. In twilight or scotopic vision the foveal or central portion of the retina is less sensitive than the contiguous surrounding portions. In such vision sensibility in general is a function of the dark adaptation of the retina. Complete dark adaptation is rarely realized, but various degrees of dark adaptation characterize vision under street-lighting conditions. Dark adaptation is built up slowly for some minutes after the removal of all bright lights and more rapidly during a period of one-half hour or more until with continued darkness, it attains the approximate level of retinal sensibility which the conditions will permit. Dark adaptation is easily destroyed by the intrusion of a bright and powerful light source within the field of vision.

Under conditions of dark adaptation, sensibility near the central portion of the retina is increased when the area of stimulus is increased. When the intensity of the light stimulus becomes feeble, the eye in general becomes relatively more sensitive to light of the shorter wave length. This is known as the Purkinje effect and is usually associated and complicated with the degree of dark adaptation of the eye.

From the foregoing statements we may conclude that in street lighting, especially under conditions of feeble intensity, best vision requires (1) absence from the field of view of powerful and bright light sources, (2) illumination of as large areas as practicable and (3) light in which the shorter wave lengths are prominent.

Street-lighting theories should be comprehensive. While it is often desirable to separate a given variable and to study it to the exclusion of other variables in order to ascertain its characteristics, yet no one variable should be considered with respect to its effect upon the problem as a whole without taking into account the effect of all other variables. Thus, while the foregoing general requirements for good vision under street lighting conditions appear to be fundamentally sound, yet it may be quite possible that other considerations may in particular instances make it desirable to transgress these rules in order to obtain a better final result.

*Indoor vs. Outdoor Lighting.*—An important distinction between street lighting and interior lighting is this—poor lighting of interiors results in ocular discomfort due to difficulty in seeing things well

enough; poor lighting of streets results in failure to see things. In the lighting of interiors the problem is rarely that of detecting the presence of objects, while in the lighting of streets this, to a large degree, is the principal object. Under interior illumination we rarely have recourse to rod vision. Cone vision prevails almost exclusively. In the streets at night rod vision predominates and the situation is complicated by a frequent shifting from rod to cone vision. Under the usual interior illumination we discriminate fine relief; we distinguish colors. Under the usual street lighting we discover objects and consciously or unconsciously classify them with respect to type, but generally speaking we are not able to, and perhaps do not desire to, discriminate details or distinguish colors.

When the lighting is intensified, as in the important streets of the city, other secondary purposes are served. Here one may be able to identify the color of an automobile or to recognize a passer-by. Visual conditions and revealing processes are more nearly similar to those which obtain in indoor lighting. That is, one discriminates detail, color, etc. This more expensive street lighting of necessity must be restricted to the principal streets of a city. It is limited to a relatively small area. As shown elsewhere street-lighting problems are less difficult under such conditions.

In the great majority of cases streets are lighted to a low intensity. Reliance is placed almost entirely in large shade contrasts and in contour rather than upon discrimination of detail. It is important to remember this distinction. If the details of a surface are to be described, theoretically at least the most important consideration would be the securing of uniform vertical illumination. Such discrimination, generally speaking, is beyond the scope of the average street-lighting system. In practice, perception consists first in detection of the presence of an object, and second in recognition of the object. If the object is of considerable size, it is detected because it is lighter than its background and surroundings, or darker, or because it casts a shadow which can be seen. One can detect the presence of an automobile, but may be unable to distinguish the make. The size and contour classify the object, but the color is not revealed. The size and contour may make it evident that another object is a person. The lighting is sufficient to permit perception of his movements, but it does not reveal the color of his dress.

*Silhouetting.*—In warm weather, light-colored fabrics are common in the apparel of women and children if not of men. With this exception, nearly all objects which it is important to perceive when

traversing a street, whether they be objects on the street or irregularities in the street surface, tend to be either the same shade or of a darker shade than the street surface. The majority of objects and pavement irregularities are thus not light in color, and on this account it is the most usual consideration that the contrasts perceived are those of dark objects against lighter backgrounds.<sup>12</sup> It should be noted that dark objects are the most difficult to perceive and that their perception involves the most important part of the street-lighting problem.

When the objects are large, in the majority of cases they are seen as silhouettes. Fig. 11 is a comparison of a man seen in the street at night; first by direct light that illuminates to a degree which makes it possible to see him even if he were not contrasted against the background, and second, when seen as a silhouette in another portion of the street where the illumination is too feeble to reveal the details. Even in the first case it will be observed that he appears as a silhouette, though less strongly contrasted against the background than in the second case.

Fig. 12 is a comparison of an observation target viewed in turn from opposite directions. The target is painted substantially the same color as the street. Viewed from the side it is well illuminated from a near-by lamp. It is very difficult to see because its brightness is substantially the same as that of its background. Viewed from the opposite direction it is dimly illuminated from a distant lamp, but is readily seen as a silhouette because its background is much brighter than its observed surface.

While this discussion refers more especially to the great majority of street lighting which is not of a high order of intensity, yet it may not be out of place to note at this point that no street lighting is so intense as to eliminate silhouetting as a fundamentally important method of discernment. Fig. 13 is a picture of a silhouette in a brilliantly lighted street.

The difference between brilliantly lighted and dimly lighted streets in regard to silhouetting is that on the brilliantly lighted streets one is not dependent solely upon the silhouette effect for discernment, whereas in many parts of a dimly lighted street he must rely exclusively upon this method. Even in brilliant sunlight most large objects are seen on the street as silhouettes for the reason that at a distance one cannot discriminate fine details of relief and color, and that upon a near view one ordinarily is not



Fig. 11.—Man seen by direct illumination and by silhouetting.



Fig. 12.—Observational target seen by silhouetting and by direct illumination.

*(Facing page 434.)*





Fig. 13.—Silhouette in brilliantly lighted street.

Fig. 14.—Depression in pavement as revealed by light from two directions.

sufficiently interested to do so, especially when moving rapidly, as in an automobile.

When the illumination is markedly variable, objects between lamps are seen as silhouettes offering still greater contrast to their background because a part at least of such background is more brilliantly lighted than under uniform illumination. When objects are near to and just beyond a lamp on a non-uniformly lighted street, they are more likely to be seen as under interior illumination through the discrimination of surface details because, other things being equal, the illumination at such points is more brilliant than is the case of a uniformly lighted street. Thus a pedestrian seen throughout the length of a uniformly lighted street as a silhouette offering mild contrast against the background would appear on a non-uniformly lighted street first as seen under dim interior illumination and then as a strongly contrasting silhouette.

*Direction of Light.*—Consider an abrupt depression in the roadway (see Fig. 14). This is discerned readily if the rim or the exposed floor of the depression is markedly lighter or darker than the surrounding roadway. If the light falling upon the depression is derived from a distant lamp opposite the observer, the observed rim is likely to be left in darkness and to appear much darker than the roadway, thus revealing the presence of the depression. If the light falls at an acute angle from a lamp behind the observer, the observed rim is likely to appear brighter than the surrounding roadway, thus revealing the presence of the depression. In either case the floor of the depression may be darker than the surrounding roadway, because it lies in the shadow and if seen it also will reveal the presence of the depression. On the other hand, if the light is received from a near-by lamp slightly nearer the observer than is the depression, the rim and floor of the depression may be illuminated to about the same brightness as the surrounding roadway and there may be little or no contrast to reveal the presence of the depression. Thus with one-tenth the illumination a depression midway between lamps may be more readily discerned and avoided than a depression near the lamp illuminated to ten times the intensity. This is an illustration of the importance of contrast as affecting street-lighting visibility and incidentally of the fact that lighting effectiveness is by no means dependent exclusively upon illumination intensity.

#### DESIGN

Street-lighting design is subject to certain fundamental conditions as follows:

Class of city.  
Municipal appropriations.  
Class of street.  
Buildings along the street.  
Trees.  
Roadway and curvature.  
Lamp characteristics.  
Human characteristics.

Let us consider briefly these several unalterable or nearly unalterable conditions.

*Class of City.*—Cities differ greatly in respect to their industries and activities. In some cities, such as New York and San Francisco, night life is highly developed. In others, which the writer does not have the temerity to illustrate by examples, the streets are not used largely by night. This difference in characteristic may reasonably be expected to have a bearing upon the intensity standards of street lighting. Differences in real estate values and in traffic density also distinguish cities, and these too have a direct bearing upon municipal appropriations for street lighting.

*Municipal Appropriations.*—Money expended for street lighting is fixed usually as a compromise between the wishes of the engineers having the lighting in charge and the desires of those who pass upon the appropriations. Ordinarily the problem is to secure the most effective street lighting with the money which is available.

*Class of Street.*—In every city, streets vary in importance throughout a wide range. It is customary to adjust intensity standards of street illumination with reference to relative real estate valuations, traffic density and safety requirements for each locality.

*Roadway.*—The nature of the pavement, street gradient and curvature are important conditions which have to be taken into account. All affect directly the problem of lamp locations and the distribution of roadway brightness with respect to incident light.

*Trees.*—The presence or absence of trees likewise enters into the design in an obvious manner. If lamps are mounted well out over the roadway, the sidewalks are likely to be lighted poorly. If lamps are mounted low over the curbs, the roadway suffers.

*Lamp Characteristics.*—These are treated under "Illuminants."

*Human Characteristics.*—These are discussed in another lecture at length, and visual characteristics are referred to briefly elsewhere in this lecture.

Within the limitations of the above conditions which cannot be

changed or which can be changed only with great difficulty, design ought to be based upon a thorough understanding of what the street lighting is intended to accomplish. Before addressing himself to design the engineer in charge should determine beyond all question what he expects of the street illumination. Does he want uniform illumination, and if so what component or quality of the illumination does he desire to have uniform? Does he want to avoid glare, and should he design the installation with this in view as a paramount object, or, as appears to the writer to be the more logical and reasonable procedure, should he seek to accomplish the purposes set forth as the three major objects of street lighting described in the early part of this lecture? Not until this point is settled should he proceed to consideration of means of accomplishing the desired objects with the lighting which is to be designed.

With the purposes to be served defined after careful consideration, actual design of the lighting installation may be undertaken. At this point there are certain principles of good street lighting which as generalities find proper place in a lecture of this kind. These embrace generally accepted rules which may be regarded as established, and other propositions, ranging from notions to rather generally accepted tenets which are subscribed to by various engineers, but which have not yet received general acceptance. Some of these latter are at present moot questions and it is the lecturer's purpose in such cases to indicate the fact in order to enable his audience to attribute proper weight to each such proposition.

There are certain obvious important features of street lighting which are essential to effectiveness, including good maintenance of posts, lamp fixtures and lamps, reliability and continuity of service, etc. For the purposes of this lecture such features characteristic of a first-class street-lighting service may be assumed. With these disposed of, effectiveness of street illumination may be said to depend upon the following factors:

- Intensity of light upon the street—average and variability.
- Brightness of street surface.
- Visual angle between lamps and street surface.
- Extremes of contrast between lamps and street surface.
- Extent to which the visual field is illuminated.
- Extent to which the visual field immediately adjacent to light source is illuminated.
- Contrasts produced on the street surface.
- Contrasts produced on objects on the street.

Appearance of installation by day and by night.

Appearance of street and buildings by night.

*Average Intensity of Light upon the Street.*—The intensity of light upon the street is one important factor affecting the value of the street lighting. The total flux of light or the average intensity throughout the length of the street should however be considered in connection with the variability of intensity and with the proportion and utility of the light delivered upon buildings. The weight to be attributed to different degrees of variability as increasing or decreasing the utility of the illumination cannot be stated definitely.

Considering first average intensities the following table is offered to show modern practice in this country.

TABLE III.—TYPICAL STREET LIGHTING INTENSITIES

Class of street	Average horizontal illumination intensity	Desirable characteristic
Important avenues and heavy traffic streets.	0.5 to 1.0 foot-candle (lumen per square foot).	Ample light on building fronts.
Secondary business streets.	0.1 to 0.2 foot-candle (lumen per square foot).	Ample light on buildings.
City residence streets . . .	0.05 to 0.10 foot-candle (lumen per square foot).	Subdued light on building fronts.
Suburban highways . . . .	0.02 to 0.04 foot-candle (lumen per square foot).	Maximum light on roadway.
Suburban residence streets.	0.005 to 0.02 foot-candle (lumen per square foot).	Very subdued light on building fronts.

The above intensities should be considered in connection with the fact that municipal appropriations very generally are inadequate. They therefore do not necessarily represent modern ideas of best practice; they represent rather the status attained in practice, the occasional exception conforming to the criterion of desirability entertained by street-lighting engineers. As a standard for guidance therefore it is probable that the higher value shown may be accepted with greatest safety.

*Per Cent. Flux Delivered Directly upon the Street.*—With a method available for the ready and convenient computation of light flux delivered upon the street surface, we may carry out some simple but instructive studies of the influence of changes in location and equipment of street illuminants upon delivered flux. For the purpose we shall adopt certain standard conditions which will obtain unless

otherwise stated. These include a level and straight street free from trees and other obstructions, the width from curb to curb being 50 feet with sidewalks 15 feet wide, lamps being mounted at a height of 22 feet.

Fig. 15 shows for each of the four candle-power distribution characteristics which have been referred to, the change in per cent. flux delivered directly upon our arbitrarily selected street due to alteration in the location of the illuminant transverse of the street. Thus when the lamps are mounted over the middle of the street, the maximum flux is of course delivered upon the street surface. When these lamps are moved over to the curb 25 feet away from the

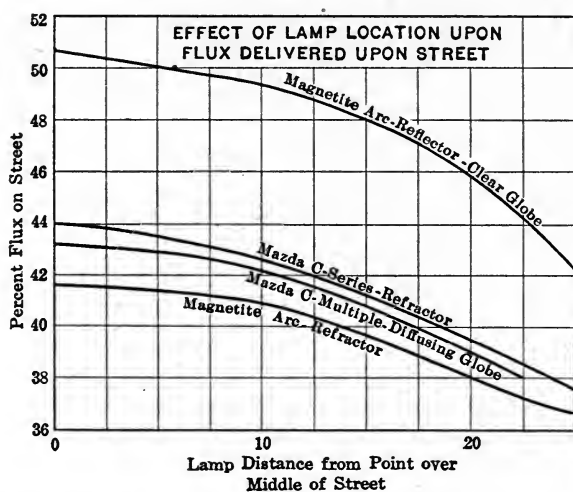

Fig. 15.—Variation of percentage of flux delivered on the street with position of lamps.

center of the street, the same standard mounting height of 22 feet being preserved, the reduction in flux delivered directly upon the street ranges from 12 to 16 per cent. This is of course based upon the assumption that the street is free from interference due to the presence of trees and other causes.

From Fig. 16 we may derive some interesting relations between lamp mounting height and per cent. flux delivered directly upon the street. In order to make the diagram useful for other purposes, the scale of abscissa shows ratio of width to height. The four curves are applicable to our four selected candle-power distribution characteristics. The variation in per cent. light flux delivered upon the street due to a change in the height of the lamps or in the width of

the street when the lamps are mounted over the curbs is indicated. When the values are taken from the chart it will be seen that, for the candle-power distribution characteristics represented, when the lamp is raised from a height which is half the width of the street to one which is three-quarters the width of the street, the reduction in

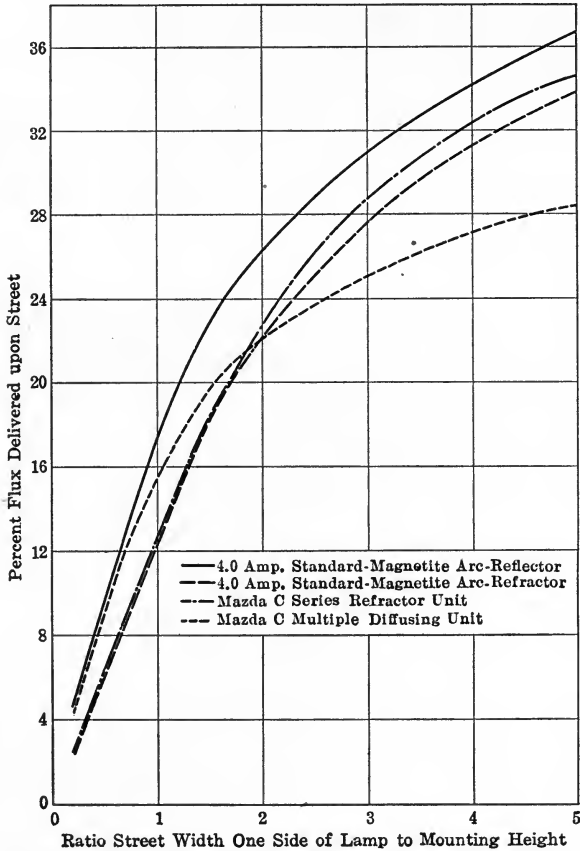

Fig. 16.—Variation in light flux delivered upon streets of various widths with change in lamp mounting height.

flux delivered upon the street ranges from 12 to 21 per cent. In order to consider a particular case, it may be assumed that the lamps are mounted over one curb of our standard street. The per cent. light flux delivered upon the street with various mounting heights will then be as indicated in derived Fig. 17.

*Light on Building Fronts.*—The total or average light flux delivered

upon the street surface of course does not represent a complete statement of lighting value, though it is a very important part of such complete statement. Light delivered upon building fronts ranges from perhaps a negligible value in residential streets, where it is often undesirable, to a high value in important avenues where it is indispensable. Figs. 18 and 19 are examples of building front illumination representing extremes of good and bad practice.

*Variability of Illumination along Street.*—The complete qualities of the illumination cannot be known unless there is a statement

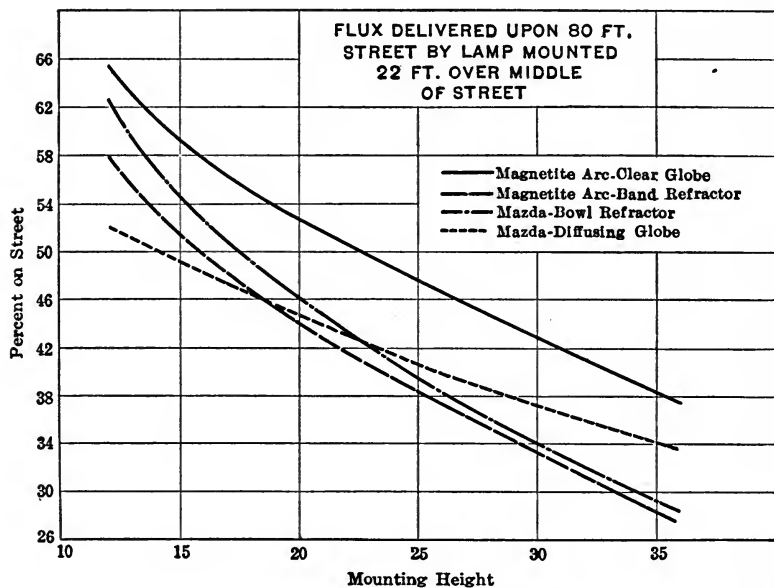

Fig. 17.

indicating the variability of the distribution of light on the street surface itself.

It has long been a tenet of street lighting that invariable or uniform illumination is the great desideratum.<sup>13</sup> This may be qualified perhaps by saying that those who so believe are satisfied to obtain illumination which is nearly uniform, varying from maximum to minimum by no more than say 5 to 1. Recently it has been further qualified by the concession that when the total light produced falls below a certain minimum which corresponds roughly with residence street lighting, the uniformity criterion may have to be abandoned as impracticable for the reason that it may be possible



to light such streets better with a degree of variable illumination than with uniform illumination.

While many writers insist upon the general quality of uniformity, most of them are a little indefinite in stating what component of the illumination should be uniform. All desire uniformity of incident light, but opinion seems to divide some favoring uniform horizontal illumination and others uniform vertical illumination.

It would appear that the desire for uniformity arises from the view that by this characteristic the best lighting effects will be obtained throughout the length of the street. If the horizontal illumination is desired to be uniform, it is in order that the street surface may be seen to best advantage. If the vertical illumination is desired to be uniform, it is to the end that faces of passers-by may be distinguished. It may appear reasonable to consider that in order to maintain visibility conditions uniformly along the street, the intensity of incident light must be uniform. The chain is only as strong as its weakest link. The minimum illumination intensity is said to be the weakest link in the chain of street illumination. Therefore, the minimum must be increased until it attains the average. So persuasive is this view that in England there appears to be rather widespread belief that a correct basis of rating street illumination must be closely associated with a minimum intensity.

It is perhaps inherent in the problem that differences of opinion should exist as to the relative importance of uniformity in horizontal and vertical components of the illumination. The two serve quite different purposes; each is important. Unfortunately the requirements for the two are not identical. Uniform vertical illumination imposes a requirement for a somewhat higher angle of maximum light distribution than does uniform horizontal illumination. Advocates of uniformity in general manifest a tendency to accept either of the two distribution characteristics which it is possible to obtain, being satisfied if they can realize either the one or the other of these uniformity conditions.

Uniformity of illumination is naturally approximated when a street is lighted brilliantly by closely spaced lamps. It does not have to be striven for and can hardly be avoided. In such streets there is ample intensity for all purposes and the desirability or undesirability of strict uniformity of lighting need not be discussed. It is only in streets illuminated to lesser intensities where uniformity can be attained only by using a larger number of small lamps or by modifying radically the light distribution curve that the desirability



Fig. 18.—Building well illuminated by street lamps.

(Facing page 442.)

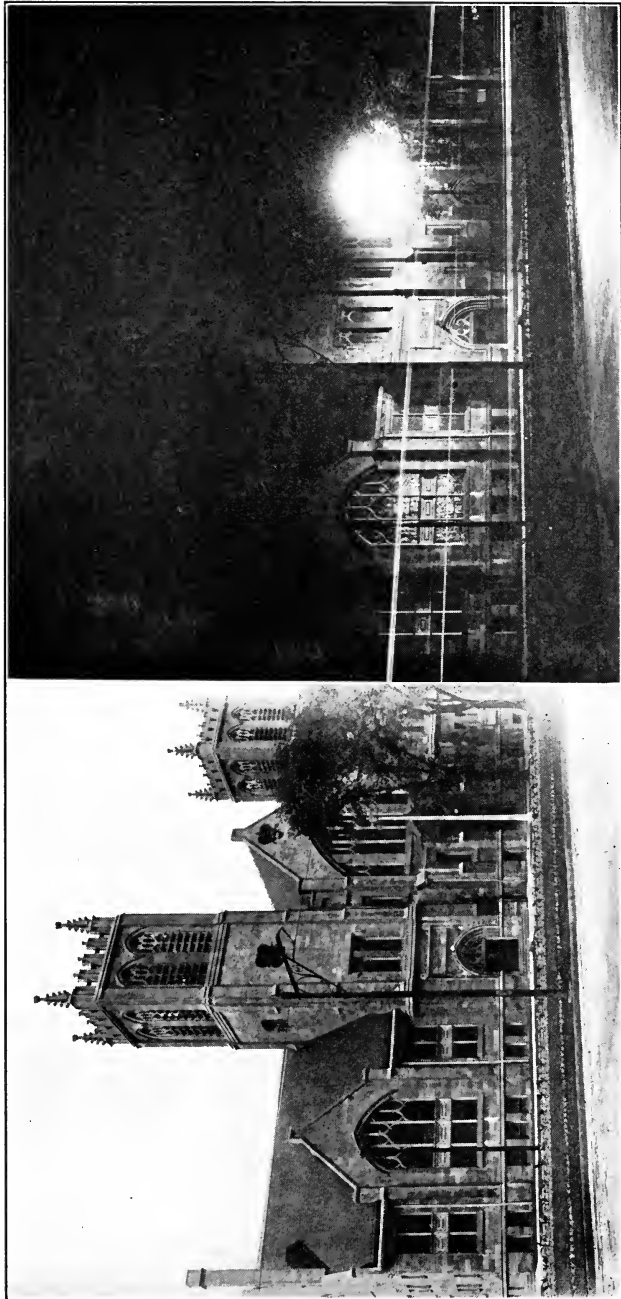

Fig. 19.—Building poorly illuminated by street lamps.

or undesirability of uniformity of light distribution along the street becomes a matter for discussion.

In the practical lighting of such streets uniformity of illumination can be obtained either by raising the angle of maximum dis-

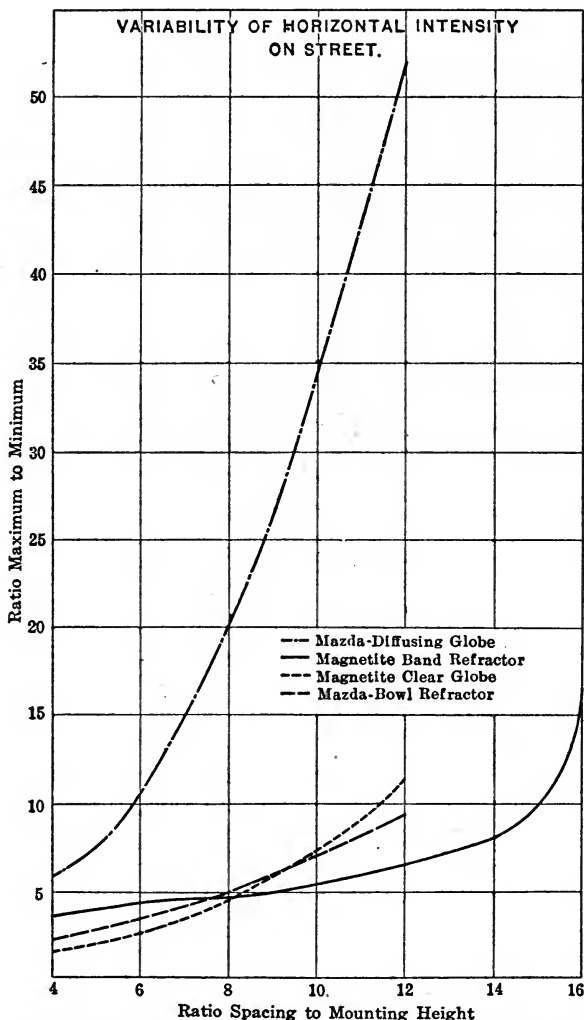

Fig. 20.—Variation of horizontal illumination with mounting height.

tribution about the source of light or by multiplying the number of sources. Assume that it is desired to increase the uniformity of horizontal illumination by substituting for the diffusing globe equip-

ment shown in Fig. 6, the prismatic refractor equipment shown in Fig. 5. Fig. 20 shows that if the spacing interval is ten times the mounting height, this change of accessories will reduce the ratio of maximum to minimum horizontal illumination intensity from 34 to 7. This change would be attended by certain changes in the lighting conditions as follows:

(a) The proportion of light utilized would be decreased. It is not altogether a simple matter to compare these distribution curves to derive the percentage of light utilized. If the illuminants are employed on a business street, much of the light delivered above the horizontal by the diffusing globe will have to be considered as useful. If the illuminants are employed in outlying streets, the light delivered above the horizontal would not be of much utility. Considering the lamps to be mounted over the selected 80-foot street, 23 per cent. of the light in the lower hemisphere would be delivered upon the street surface if the refractor is used and 32 per cent. if the diffusing globe is used. Fig. 16 shows that if we consider the total light produced, the diffusing globe delivers a larger proportion on the street if the street width on each side of the lamp is no greater than 1.8 times the mounting height, while the refractor delivers a larger proportion of the total light upon the street if the ratio is greater than 1.8.

(b) The maximum intensity delivered upon the street surface near the lamp is much reduced.

Such reduction is at all times likely to reduce the effectiveness of the lighting and especially so when the lamp is located over street intersections where the bright pavement near the lamp is visible from four directions.

(c) The effect of glare is increased.

The brightness of the light source from 65 to 75 degrees above the nadir is increased about four fold, this being due in part to higher intensity in this zone and in part to smaller size of the accessory.

To sum up, when the variability of horizontal illumination as measured by the ratio of maximum to minimum is reduced from 34 to 7 by substituting a bowl refractor for a diffusing globe, the utilized light flux is reduced, the maximum intensity delivered upon the street near the lamp is reduced and the glare is increased. A comparison of two particular equipments has been chosen as the basis of this discussion. Some other comparison might modify the discussion somewhat. The general tendency, however, would be in the direction indicated and the case chosen is peculiarly appropriate in that a choice between these two forms of accessories presents itself in most present-day designs.

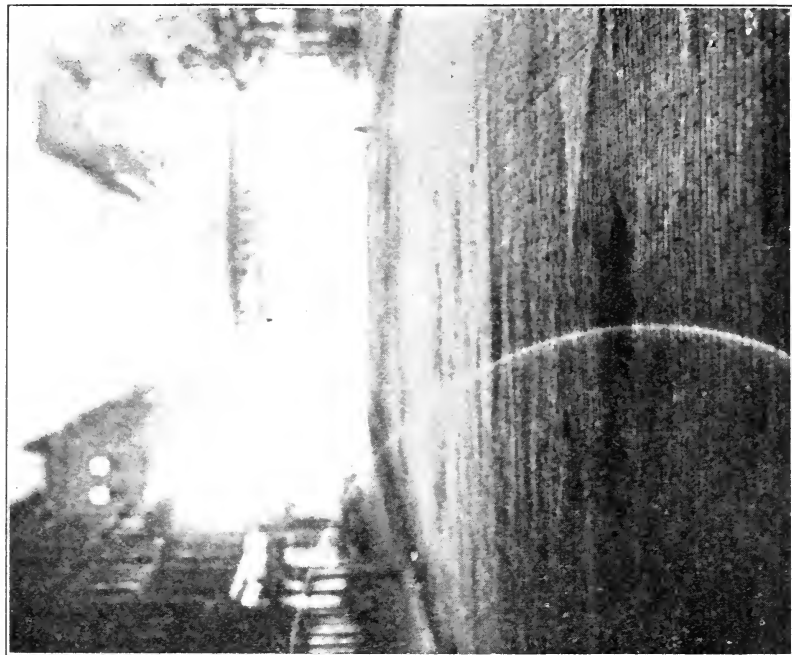

Figs. 21 and 22.—Depression in pavement as revealed by light under two different conditions.

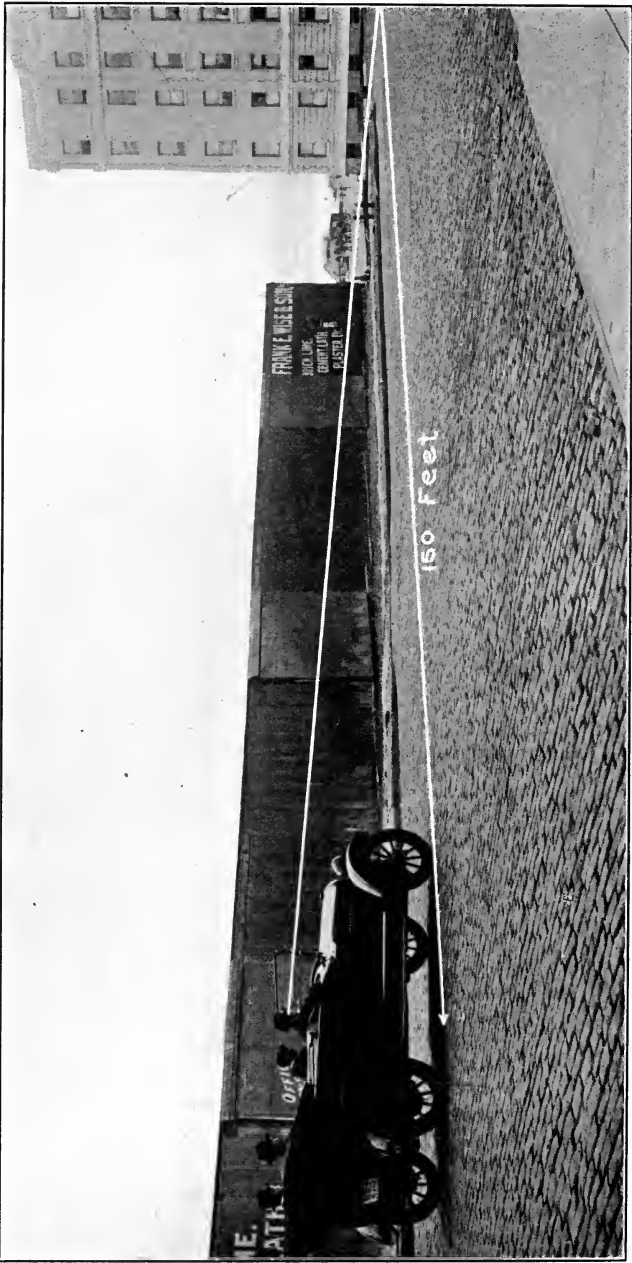

Fig. 23.—Illustration of "chauffer's angle" of view.

In the second case (numerous small lamps) there is involved:

(d) Increased expense for both installation and operation.

(e) Likelihood of reduced effectiveness due to multi-directional light and consequent reduction of contrasts.

This effect was brought out clearly in Dr. Bell's lecture.

It might be well to incur the foregoing disadvantages involved in securing uniform illumination if any important purpose were to be served by uniform illumination. But it is a fact that uniformity of incident light is not necessary to the unvarying maintenance of the most important visibility conditions throughout the length of the street. This is evidenced by the following:

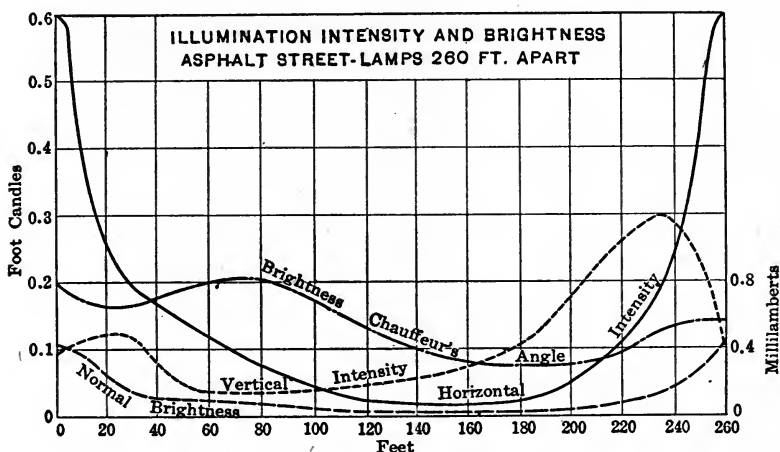

Fig. 24.—Illumination intensity and brightness.

(f) At points between lamps where intensity is feeble, superior direction of incident light tends to compensate.

Figs. 21 and 22 show two somewhat similar depressions in the street surface. The first is illuminated principally by a lamp which is removed about 25 feet and which is behind the camera. The latter is illuminated by a lamp which is removed about 150 feet and which is beyond the depression. Unquestionably in driving or walking, one would be more likely to see the depression in the pavement in the latter case in spite of the fact that the intensity is much less than that at the depression shown in Fig. 21. This is because the direction of the light is such as to produce in Fig. 22 a strong contrast which reveals the presence of the depression in spite of the low intensity. Generally speaking, light delivered at acute angles midway between lamps is more effective in revealing surface irregularities than is light near the lamps.



(g) At points between lamps where intensity is feeble, silhouetting is effective.

For the principal purpose of the street lighting, the discernment of large objects, the serviceability of this illumination is greater midway between lamps than it is at the point of highest intensity. (See Figs. 11 and 12.)

(h) At points between lamps where intensity is feeble, brightness is likely to be maintained at a fair value.

Fig. 24 shows illumination data for Avenue A between 68th and 69th Streets, New York City. You are asked to observe that in the region between adjacent lamps along a line halfway between the curb and the center of the street the variability of illumination as measured by ratio of maximum to minimum is 40 to 1 for the horizontal illumination and 8.4 to 1 for the vertical illumination. Now note the curve of street brightness under this illumination as measured at an angle of  $3\frac{1}{2}$  degrees (known colloquially as "chauffeurs' angle" and illustrated in Fig. 23). This brightness is as nearly uniform as might be wished, the ratio of maximum to minimum being 2.17 to 1. A similar discrepancy between horizontal illumination intensity and brightness is encountered when measurements are made along a line transverse of the street. The brightness between lamps when viewed at "chauffeurs' angle" is many times as great as the normal brightness when viewed from directly above. Measurements of brightness viewed from above show that this value is substantially proportional to the horizontal illumination intensity.

Avenue A is paved with asphalt. It is in the poorer section of the city; its vehicular traffic consists principally of horse-drawn vehicles. Judging the pavement in the daytime an inexperienced observer would conclude that it offers but little specularity; certainly it is less specular than is the average asphalt street, yet on this street variable illumination intensity is translated into practically uniform brightness when the street surface is viewed as in driving.

As a matter of fact, little if any consideration has been given by uniformity adherents to the importance of brightness uniformity as distinguished from uniformity of some component of incident light. This aspect of the matter was perhaps first emphasized by the lecturer in 1910.<sup>11</sup>

It is the lecturer's view therefore that uniformity of incident light on the street is unnecessary because: (1) with moderately variable illumination, because of more favorable direction of incident light, one sees surface irregularities as well in the darker regions between lamps as in the more brightly lighted regions; (2) one sees large objects on the streets as silhouettes in the dimly lighted regions even more surely than in the brightly lighted regions and (3) the appearance of the street surface approximates uniform brightness

even with marked diversity of incident light. These views have been fully confirmed in the investigations of street lighting effectiveness conducted during the past two years under the auspices of

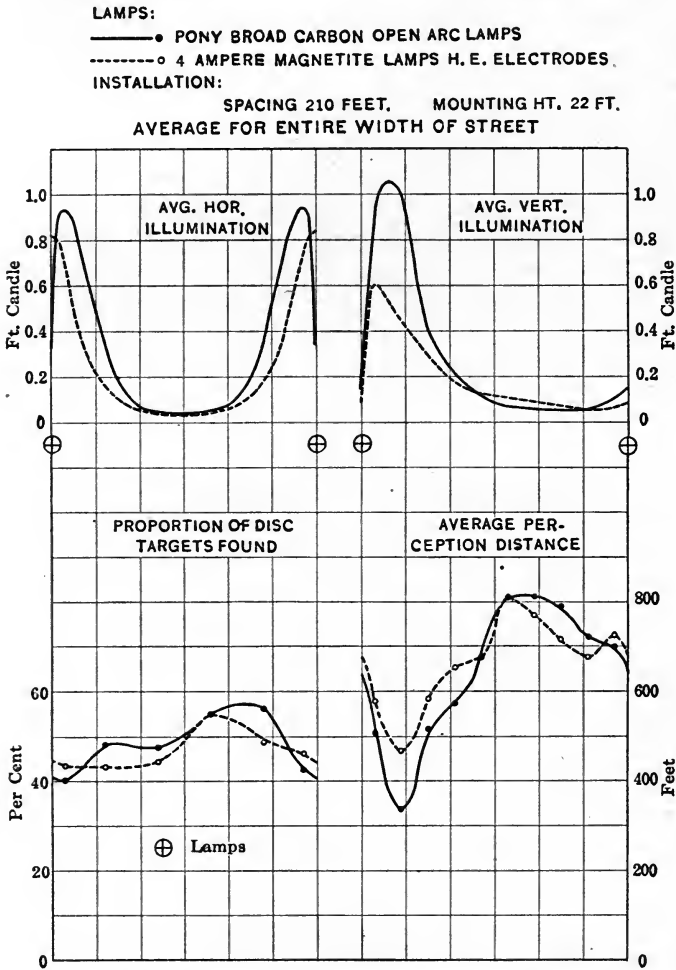

Fig. 25.—Illumination intensity and target findings.

the Street Lighting Committees of the National Electric Light Association and the Association of Edison Illuminating Companies.

An example of findings in local observational tests\* will further

\* Courtesy of the Philadelphia Electric Company.

illustrate these points.<sup>14</sup> Fig. 25 shows the distribution of horizontal and vertical illumination along the street under two systems of lighting. Below these curves are the findings in observational tests. The targets (see Fig. 34) of the disc type were found by pedestrians quite as generally between lamps as in the more brightly lighted regions near lamps. The targets of the cylindrical type were seen at quite as great distances when located between lamps as when located near lamps, yet the horizontal illumination intensities under these two systems varied respectively from 23 to 1 and from 17 to 1.

It is the lecturer's view that strict uniformity of illumination on all but the most brilliantly lighted streets can be attained only with added expense and with some difficulty; that its attainment is attended by disadvantages; and that visibility requirements do not demand it. It is submitted therefore that a moderate diversity of intensity along the street is a more reasonable criterion.

#### GLARE

Glare in street lighting manifests itself principally in reducing visual ability, in causing ocular discomfort or annoyance, and in rendering an installation less attractive. In a general way it may be said that methods of reducing glare influence all of these manifestations, although in some cases the effect upon one manifestation may be more pronounced than upon another. Little is known concerning the numerical relations involved in the reduction of glare in street lighting.<sup>15</sup>

We do know, however, that glare is reduced:<sup>16</sup>

1. If the power and brightness of light sources at observed angles are reduced.

The customary method of reducing glare consists in surrounding the light source with a diffusing globe of as large size as may be regarded as desirable. It is to be remembered that assuming complete diffusion by the accessory the brightness of a globe decreases inversely as the square of its radius, and that therefore with the same lamp a 16-inch globe will be only 40 per cent. as bright as a 10-inch globe.

A more elaborate method recently advocated and embodied in some modern practice consists in limiting within a lower zone which is relatively free from observation, the greater part of the light flux, and allowing little or no light to emanate from the source at angles which will be observed in the ordinary use of the street. This method is open to the objection, (1) that it requires for successful application either excessively great

mounting heights or very short spacing intervals, both involving large cost; (2) elimination or reduction of flux at angles which are very useful when the characteristics of specular pavement are considered; (3) as applied thus far this method usually carries with it so great a reduction in the light delivered upon building fronts as to make the effect unsatisfactory on streets of commercial importance.

2. If the visible region immediately contiguous to the light source is made bright.

This is a little apprehended effect. It is probably associated with the ocular characteristic described elsewhere according to which, under conditions of twilight vision, retinal sensitiveness is increased if the area of the stimulus is increased. One reason why the exposed arc of the magnetite lamp has been found to be a less serious source of glare than might have been anticipated is doubtless the presence of a reflector immediately adjacent to the arc. When mounted in streets any light source presents a less serious source of glare if it is seen against a background of a light-colored building than it does if its background is in darkness.

3. If the surfaces viewed are made bright.

In street lighting the surface viewed is generally the street itself. This may be increased in brightness by reason of more powerful lighting or by reason of a higher albedo, or, under certain conditions, by reason of increased specularly. The effect of glare from a given source is diminished if the street surface is rendered brighter in any of these particulars.

4. If the visual angle between light sources and the observed surface is increased.

The general application of this is to be found in a demand for increased mounting heights as light sources become more powerful and more bright. On curved roadways this finds application if a lamp is mounted over the inner curb, the visual angle between it and an object in the distance beyond the curb is likely to be small and the glare reduces visibility markedly. If the lamp is mounted over the outer curb, the visual angle between it and the roadway beyond the curb is increased and the glare is less serious (Fig. 32).

5. If a large portion of the field of view is illuminated.

Also, if the general field of view contains many lighted surfaces, the effect of glare will be less than if large portions of the field of view are left in darkness.

#### STREET PAVEMENTS

The light reflecting qualities of street pavements both as respects reflection coefficient and specularly are of prime importance in the street lighting problem. A street pavement which is naturally

light in color and which can be kept from darkening seriously under use obviously is capable of enhancing greatly the effectiveness of the street lighting provided by any system. Most pavements darken in use, especially under automobile traffic, where oil drippings bring early discoloration. This would result in rendering ineffective the most powerful of street lighting systems if it were not for the saving fact that in practically all such cases the pavement takes on a considerable degree of specularity, especially under automobile traffic. Fig. 26 is a view of the wooden block pavement of Columbus Circle, New York City. The background reveals the polish resulting from automobile use. The foreground consists of the same pavement which is not traversed by automobiles and is not specular.

The rapidly increasing use of automobiles is exerting a marked influence on this aspect of the street lighting problem and specularity of street pavement must now be taken into account in practically all streets that are lighted artificially.

The higher spots of the pavement take on a polish and become small mirrors on the street surface. In driving one views the pavement at an angle of perhaps from 1 to 5 degrees. Each street lamp may be seen in many of these small mirrors, the result being a broken streak of light along the street not unlike moonlight on the water. It should be noted that it is the distant lamps and not the nearby lamps which are seen reflected in these little mirrors. If a large number of distant lamps are within view at a given time, especially if they are distributed across the street, the result will be many streaks of light side by side, all contributing to render the pavement bright. Generally speaking, specular pavements are dark in color, and under diffused light, as in the daytime, appear incapable of reflecting light advantageously as compared with other pavements. At night, however, specular pavements usually exhibit characteristics which promote visibility. Figs. 27 and 28 for example are comparisons between suburban roads, one roadway in each case being specular and the other a dirt road which does not reflect light specularly. While the lighting systems are not strictly comparable, yet both comparisons indicate the fact of favorable reflection from the specular pavements and unfavorable reflection from the mat surface pavements. Fig. 29 is a view of a fairly wide street lighted by lamps which are mounted over curbs. It will be observed that there are many such streaks of light along the sides of the street, but that the center of the street appears dark. This installation, by the way, was designed to produce uniform illumination.

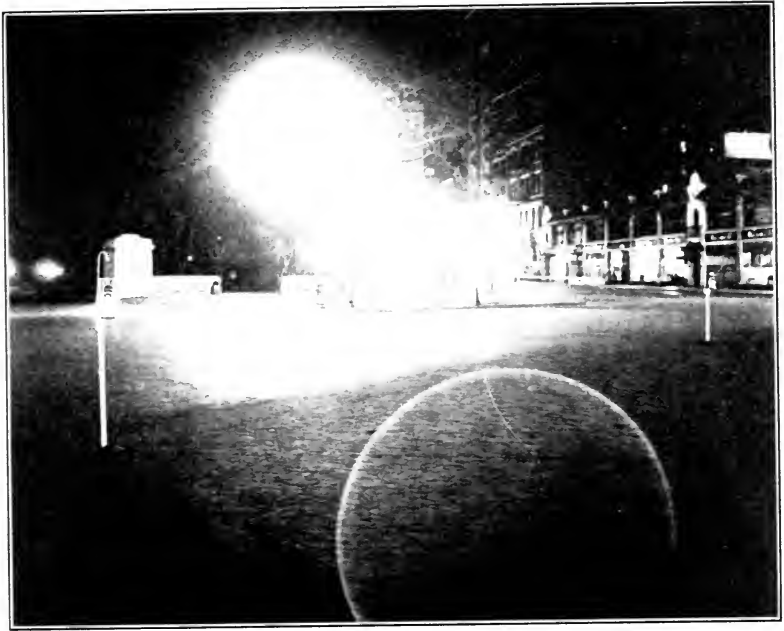

Fig. 26.—Showing effect of automobile traffic (background) in polishing pavement.



Fig. 27.—Mat and specular road surfaces.

(Facing page 450.)

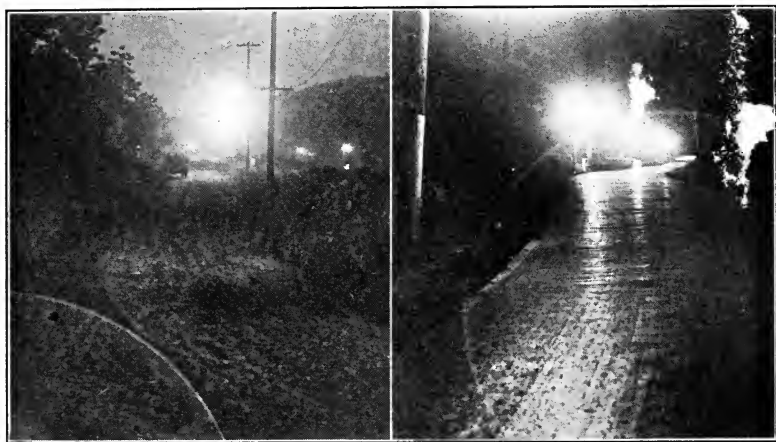

Fig. 28.—Mat and specular road surfaces.



Fig. 29.—Uniform intensity of incident light. Variable brightness.



Fig. 30.—Driveway illuminated by three rows of lamps.  
(Facing insert Figs. 28 and 29.)



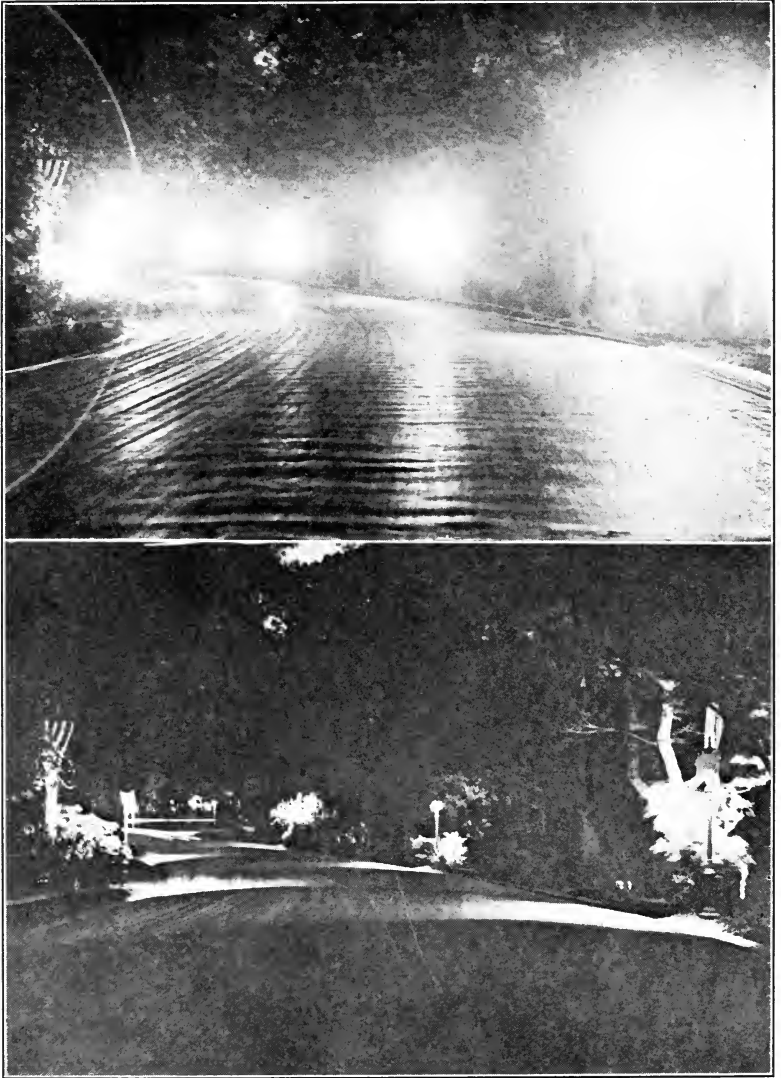

Fig. 31.—Two views of a drive, without and with lamps concealed.

On the other hand, Fig. 30 is an illustration of one driveway of a wide street illuminated by three rows of lamps. The streaks of light are in this case distributed to better advantage across the street, creating a general appearance of uniformity which was lacking in Fig. 29. The characteristics of street pavements here introduce a condition which makes the skillful location of light sources a most important factor, affecting the value of the street illumination to the detriment of intensity considerations.

Fig. 31 offers two views of a drive in Central Park, New York, lighted by lamps which are mounted 11 feet over each curb and spaced along each curb at intervals of about 75 feet staggered. At the top the view shows usual lighting conditions. The view below shows the results when the lighting is modified by covering the lamps with white pasteboard reflectors which limit the light below an angle of 65 degrees. These effectually conceal the lamps from view and increase materially the light on the street within the illuminated area. They leave the pavement relatively dark between lamps. As the pavement reflects specularly the downward lighting is not so effective as it would be otherwise. The reflectors eliminate glare but at the same time make it impossible to avail of the advantageous reflecting qualities of the pavement by intercepting all of the light which would be reflected specularly to the user of the drive. It is possible that if this pavement reflected diffusely, the covered lamps might provide superior lighting. With the specular pavement they undoubtedly provide an inferior lighting.

#### LAMP LOCATIONS

In locating lamps on the principal business streets of a city, a standard arrangement is usually desired and required and but little deviation is warranted. The precise location of the lamps is relatively unimportant as far as illumination is concerned.

In secondary streets where the lamps are likely to be rather inadequate, it is often desirable to mount them well out from the curb either on suspensions or on mast-arm posts. Usually such streets do not have many trees, and the sidewalk lighting does not suffer as a result of the central mounting.

In residence streets, where trees are likely to abound, the location of the lamps becomes much more important, the more so since fewer lamps are employed and the utmost must be made of the materials at hand. So far as the roadway is concerned, it is usually

difficult to improve upon a location over the middle of the street low enough to escape serious interference from trees and high enough to avoid serious glare. In such lighting, however, the sidewalk is likely to be neglected. If the lamps are mounted low over the curbs, in order to keep the light well beneath the limbs of the trees, the sidewalk is likely to be taken care of to a somewhat better degree, but the roadway lighting is likely to be ineffective. Abroad to some extent a combination of the two lamp locations has been found effective, large lamps being mounted over the middle of the streets at intersections, small supplementary lamps being mounted low over the curbs between street intersections. Similar arrangements have been tried in this country.

In outlying districts, parks, etc., lamp locations are usually somewhat optional. Here the illuminating engineer has an opportunity to exhibit his skill as an engineer and as an artist. By studying the topography and curvature of the roadway, by making due allowance for glare, and by taking full advantage of pavement specularity, the skillful engineer may so locate his lamps as to obtain with a given expenditure much more effective street lighting than could be had with perfunctory location of the lamps. An excellent illustration of the importance of lamp location under such conditions is afforded by the two views in Fig. 32. In the one a lamp is mounted over the inner radius of a curve in an automobile driveway. There is a great deal of light on the pavement at the curve, but the roadway beyond is obscured. The glare is very serious. In the other view the lamp has been moved to the outer curb of the curved roadway. There is less light upon the pavement in the foreground, but the curb can be seen readily. The distant roadway may be seen readily as a result of specular reflection from the next lamp, which, by the way, is located at a distance of about 900 feet.

#### SUMMARY

Summing up the foregoing comments on the design of street illumination, it will be noted that the simple method of calculating flux on the street leads to the ready establishment of relations involving the location of the lamp, its height and its equipment. Not only must the total flux delivered upon the street surface be taken into account, but the amount of light delivered upon building fronts is important. Moreover, the variability of the illumination along the street requires careful thought, especially where low intensities

prevail. The means for reducing glare are indicated, the characteristics of street pavements are illustrated and the importance of this factor is emphasized. The possibilities of improvement by skilful lamp location is the last point mentioned.

### COMPARISON AND TESTS

As street illumination is generally supplied under a contract between a municipality and a public-service corporation, there is an ever-present desire to provide some means of proving the adequacy of the service rendered. In the past too much emphasis has perhaps been placed in this connection upon the candle-power of the lamps or upon the illumination intensity. It is evident that a street-lighting service must include such important elements as reliability and continuity of operation, good maintenance of lamps, poles, lines, etc., and a satisfactory attitude on the part of the contracting company as well as reasonably good maintenance of the candle-power of the lamps. Lamps may be shown to be of adequate candle-power and yet the service in general may be unsatisfactory. On the other hand, the lamps at times may not be quite up to par in candle-power and yet the street-lighting service as a whole may be eminently satisfactory. It is desired therefore to deprecate the tendency of the past to over-emphasize this one phase of street-lighting service to the exclusion of other equally important features.

Nevertheless for engineering or political reasons the demand recurs for a measure of the illuminating value of street-lighting systems. It has been the writer's privilege during the past six years to be closely identified with efforts which have been put forth in this country to solve the problem of providing a satisfactory measure of street-lighting values for this purpose, and the statements on this subject which follow are largely based upon the experience which he has had in the conduct of investigations in this field for the Street Lighting Committees of the National Electric Light Association and of the Association of Edison Illuminating Companies.

The problem of testing street illumination is divided naturally into two parts. The first has to do with means of determining whether or not a stipulated lighting service is being rendered; the second has to do with the determination of the relative illuminating value of two different street-lighting systems.

The first of these is by far the simpler. A contract or specification for street lighting under which tests are to be performed ought

to include a description of the lamps and accessories to be employed and a statement of their photometric values, including the total flux of light, the candle-power distribution curve and a range of toleration above and below the standard within which the lamps may be allowed to fluctuate. Test of fulfilment of this part of the contract then consists in determining the total flux of light of the lamps. This may be accomplished either by determining the operating electrical values of the lamps, removing them from the circuit and sending them to a laboratory in their operating condition, or, where practicable, in subjecting them to test in situ by bringing an integrating sphere photometer to the street for the purpose (see Fig. 33). These methods are not simple. Such tests do not need to be made often, but in the event of a serious question arising concerning the adequacy of the service, they afford means which experience has shown to be most reliable for determining accurately the illuminating values in terms of the contractual provision.

The history of attempts to arrive at a satisfactory method of testing street illumination is a record of confusion,<sup>17</sup> and it now appears that much of the confusion has arisen as the result of a vain attempt to adopt some method which would at once prove fulfilment of contractual obligation and indicate the usefulness of the illumination. Thus the 1907 "Committee to Consider Specifications for Street Lighting" of the N. E. L. A. sought a measure of the illuminating value and finally recommended the mean normal illumination produced by a lamp in the street at the height of the observer's eye and at a distance of not less than 200 and not more than 300 feet from a point immediately below the lamp, as compared with the illumination provided by a standard lamp under like conditions. It would appear likewise that the Joint Committee on Street Lighting Specifications, which has labored recently in England, was actuated by a desire to combine both purposes when they recommended the minimum horizontal illumination as a measure of street lighting. The whole problem is immensely simplified if the purpose of proving fulfilment of contract is divorced once and for all from the purpose of comparing relative illuminating effectiveness of different street-lighting systems. Considering exclusively the latter problem, let it be noted that a difficulty which existed until recently has been the lack of any method for definitely comparing the illuminating effectiveness of street-lighting systems. There has been no way to determine whether the notion of minimum



Fig. 32a.—Good lighting of curve



Fig. 32b.—Poor lighting of curve.



Fig. 33.—Integrating sphere photometer in service tests.

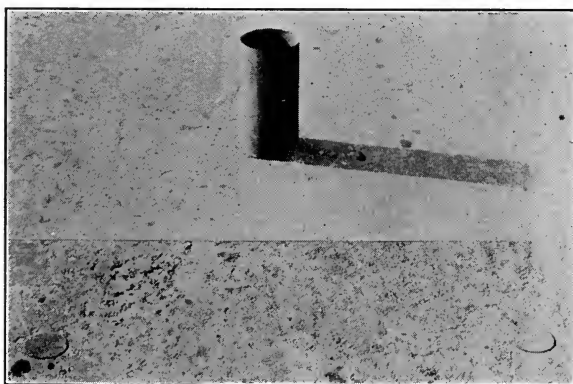

Fig. 34.—Target painted similar to street surface.

illumination or of average vertical illumination provides the nearer approach to a real measure of effectiveness. There has been no test for such proposed measures. It has been my privilege, with the aid of associates at the Electrical Testing Laboratories, to devise and with the assistance of the Street Lighting Committees which have been named to put into effect certain methods calculated to furnish a means for determining street-lighting effectiveness in several important respects and, therefore, for testing these several proposed measures of effectiveness. These methods are described in detail elsewhere.<sup>18</sup> They consisted first in classifying the purposes of street illumination through inquiry and consultation into the following three principal purposes:

Discernment of objects on the street.

Discernment of surface irregularities.

Æsthetic qualities.

Second, in devising tests to obtain relative discernment values for large objects on the street and for small objects on the street surface and in recording opinions of qualified observers in respect to the æsthetic qualities. The means for measuring discernment which were finally adopted consisted in determining the maximum distances at which automobilists could see targets painted similar to the street surface (see Fig. 34) and in determining the percentage of small targets similarly painted which pedestrians could find in walking through the street. By carefully eliminating variables and standardizing conditions, comparative discernment values were obtained for any two systems compared upon the same street at one and the same time by a given group of observers (see Fig. 34). It is the writer's opinion that these observational tests,<sup>14</sup> when impartially conducted, provide a closer approximation of the real illuminating values of street-lighting systems than have heretofore been available, and are the only reasonably adequate means thus far developed for testing the validity for proposed measures of street lighting effectiveness. With the results of the Street Lighting Committees' investigations before us, it is possible to put these proposed measures to the test and to ascertain whether or not they afford reliable measures of lighting effectiveness. From the mass of data available on this subject, I have selected a few striking instances illustrating the weaknesses of the several proposed measures; these are presented in the following table.



Description		Proposed measure of lighting	Ratio A to B		Comment
System A	System B		Proposed measure	Observational tests*	
250-c.p. lamps, light diffusing globes, 24 feet over middle of street, 150 feet apart.	250-c.p. lamps, refractor, 24 feet over middle of street, 150 feet apart.	Flux in lower hemisphere.	0.72	1.03	With system B all light was concentrated in the lower hemisphere. Much of it was redirected at angles well up toward the horizontal. The greater bulk of such light, of course, fell upon houses, trees or lawns and did not contribute materially to the street lighting. As a result substantially the same total quantity of light was delivered upon the street from system A and system B.
250-c.p. lamps, light diffusing globes, 24 feet over middle of street, 150 feet apart.	250-c.p. lamps, refractor, 24 feet over middle of street, 150 feet apart.	Intensity 10° below horizontal.	0.41	1.03	The refractor equipment receives an especially favorable rating in terms of intensity 10° below horizontal. It is very evident from the comments made above that there is no such difference in illuminating value as this form of rating would indicate.
125-c.p. lamps, light diffusing globes, 18 feet over middle of street, 75 feet apart.	250-c.p. lamps, light diffusing globes, 24 feet over middle of street, 150 feet apart.	Minimum horizontal illumination.	2.6	0.95	

Each of these three proposed measures which has been prominently urged upon attention in recent years is shown by these single instances to be invalid, as judging by the observational tests which have been made. It does not seem necessary to cite other instances or to justify the observational tests as a basis for judging the proposed measures. It would seem to be evident that each of the latter fails to measure real lighting effectiveness and that each offers a basis of rating of which advantage can easily be taken to secure a higher rating for illuminants of no greater illuminating value. Both the rating in terms of intensity 10 degrees below the horizontal and the rating in terms of minimum horizontal illumination have to do with light at a particular angle, and the rating may easily be in-

\* Automobilists' and pedestrians' tests combined with equal weight.

fluenced by altering such light without changing the illuminating value. Safer and more reliable but still inadequate measures are afforded by the average horizontal illumination and the average vertical illumination on the street. All of these, however, fail to give any credit for light directed above the horizontal, which in modern street-lighting practice, holds a very definite value. The total flux of light is a fairly reliable measure, comparing favorably with the best of the others, but inadequate in that it fails to differentiate between desirable and undesirable distribution characteristics. As previously stated, experience in the work of this Committee results in the view that the most useful single method of rating is to be had by combining with a statement of the total light flux or the mean spherical candle-power a candle-power distribution curve. The two should then be interpreted according to best judgment, the distribution characteristic being considered in the light of the facts first, that where it is desirable to illuminate building fronts, a certain proportion of the light should preferably be directed above the horizontal; and second, best lighting effects in general are obtained with a moderate diversity of illuminating intensity along the street, avoiding on the one hand, that degree of non-uniformity which results in unlighted areas between the lamps and, on the other hand, that degree of uniformity which tends to reduce contrast and definition.

Measures which have been proposed cannot be relied upon to afford an accurate and final test of street-lighting effectiveness. They may show the amount of light produced and something of its distribution. While these are important factors, yet they do not give wholly complete information. No appraisal of a street-lighting installation can be made reliable until in addition to these facts information is available including a complete description of the illuminants and their accessories, the candle-power distribution characteristic, the location of the lamps, including height and spacing, and the brightness of the light source in directions in which it is likely to be viewed. If all of this information were available, one could form a good idea of the merits of a street-lighting system for general purposes, but its effectiveness when installed on a particular street could not be approximated unless in addition information were available including a photograph and description showing the buildings and trees along the street, and indicating in a general way the extent and character of traffic and the criminal hazard in that locality.

If these statements are correct, it must be evident that there has not yet been devised any thoroughly satisfactory measure of street lighting which can be employed to show street lighting effectiveness. Through test data and capable observation the relative effectiveness of two different systems of lighting may be established, but more than this cannot be said at the present time.

For proving contractual obligations the selection of a suitable measure is simpler and nothing seems indicated which, upon the whole, is quite so generally satisfactory as a measurement of the total flux of light. Another question arises in this connection, however, which is not so simple to dispose of. This is the proper sampling of lamps in order to secure reliable indication. It should be taken for granted that the purpose of testing is to secure representative and reliable information regarding the service, and that the purpose of including test provisions in specifications for street lighting is to hold the service up to a high standard, reducing to a minimum the number of individual lamps which are of inadequate illuminating power and providing an additional incentive to keep the average illuminating power at a reasonably high value. Starting with this assumption it is regarded as good practice to select a particular area of district for investigation to secure representative sample lamps from such a district and to provide for reliable tests of such samples. The selection of samples ought to be made without prejudice and without a knowledge of the condition of the lamps which are chosen for test. Where lamps are of the incandescent type, the testing work is simplified and the following sample schedule may be expected to provide a reasonable sampling.

#### SAMPLING SCHEDULE

Number of lamps in district investigated.	Minimum number or per cent. lamps to be tested.
Less than 300	130 lamps
300-499	10 per cent.
500-2499	7.5 per cent.
2500-9999	5.0

The lamps ought to be tested in their operating condition if practicable, either by bringing an integrating sphere to the lamps in the street or removing the lamps after ascertaining their operating values and having them tested in a suitable laboratory. The average illuminating power of the samples tested ought to be regarded as applicable only to the district investigated.

## Bibliography

<sup>1</sup> Report of Committee on Street Lighting. Transactions National Electric Light Association, Technical Section, 1914, page 589.

<sup>2</sup> Report of Special Committee on Commercial Aspects of Municipal and Highway Lighting. National Electric Light Association, May, 1916.

<sup>3</sup> Report of Committee on Electric Advertising and Decorative Street Lighting. Transactions National Electric Light Association, Vol. II, 1912, page 188.

<sup>4</sup> C. A. B. HALVORSON.—“Ornamental Luminous Arc Lighting at New Haven.” General Electric Review, 1912, page 221.

<sup>5</sup> WALDEMAR KAEMPFERT.—“Ornamental Street Lighting.” Published by the National Electric Light Association, Commercial Section, 1912.

<sup>6</sup> F. A. VAUGHN.—“A Practical Application of the Principles of Scientific Street Lighting.” Transactions Illuminating Engineering Society, 1916, page 282.

<sup>7</sup> L. B. MARKS.—“The Invention of the Enclosed Arc Lamp.” Sibley Journal of Engineering, Vol. XXII, Oct., 1907.

<sup>8</sup> C. P. STEINMETZ.—“The Magnetite Arc Lamp.” Electrical World, Vol. XLIII, 1904, page 974.

<sup>9</sup> I. LANGMUIR and J. A. ORANGE.—“Tungsten Lamps of High Efficiency.” Proceedings American Institute of Electrical Engineers, Vol. XXXII, 1913, page 1935.

<sup>10</sup> “Refractor for Street Lighting.” Electrical World, Vol. LXIV, 1914, page 439.

<sup>11</sup> P. S. MILLAR.—“Some Neglected Considerations Pertaining to Street Lighting.” Transactions Illuminating Engineering Society, 1910, page 653.

<sup>12</sup> P. S. MILLAR.—“An Unrecognized Aspect of Street Illumination.” Transactions Illuminating Engineering Society, Vol. V, 1910, page 546.

<sup>13</sup> A. J. SWEET.—“An Analysis of Illumination Requirements in Street Lighting.” Journal of the Franklin Institute, 1910.

<sup>14</sup> P. S. MILLAR.—“Tests of Street Illumination.” Transactions Illuminating Engineering Society, Vol. XI, 1916, page 479.

<sup>15</sup> A. J. SWEET.—“Glare as a Factor in Street Lighting.” Electrical Review and Western Electrician, Vol. XLVI, 1915, page 439.

<sup>16</sup> P. S. MILLAR.—“Effective Illumination of Streets.” Transactions American Institute of Electrical Engineers, Vol. XXXIV, 1915, page 1429.

<sup>17</sup> J. W. LIEB, Chairman.—“Report of Committee on Street Lighting.” Transactions National Electric Light Association, 1913, page 357.

<sup>18</sup> “Report of Street Lighting Committee.” Transactions National Electric Light Association, 1914, page 589, and 1915, page 710; also P. S. MILLAR.—“Tests of Street Illumination.” Transactions Illuminating Engineering Society, 1916, page 479.



## THE LIGHTING OF STREETS—PART II

BY C. F. LACOMBE

The subject of street lighting in this lecture course has been divided between Mr. P. S. Millar and myself, and as the subject has been summarized in the syllabus of the course by the Committee on Lectures, the main subjects assigned to me will be taken up without further introduction.

### REQUIREMENTS OF CITY LIGHTING

The problem of lighting a city is to distribute the illumination in proportion to the streets, within the funds available, from that of the most congested thoroughfare to that of a sparsely settled suburb; the maximum requirement being the lighting of great squares and street intersections under conditions of heavy congestion of traffic; and the minimum being that necessary for policing the city and the prevention of accidents. One should therefore study the classes of streets existing in cities of various grades. We may arrange the grades of cities and classes of streets about as follows:

Grades of cities, by population	Class of street	Description of use
	Special or Class AA	Very important. Crossing of great streams of traffic.
	Class A	Important streets, greatly used at night.
I—500,000 and over	Class B	Well used streets.
II—250,000 to 500,000	Class C	Ordinary night use, best residence streets.
III—100,000 to 250,000	Class D	Ordinary residence.
IV—Less than 100,000	Class E	Suburban residence.
	Class F	Parkways or boulevards and suburban roads.
	Class G	Connecting country thoroughfares, State or County roads.

In all cities certain streets pass from one class to another in their course and some care is necessary in classifying them for lighting

intensities; the different grades of streets can perhaps be best identified by some examples:

*Class AA.*—Parts of Wabash Avenue and Dearborn Street, Chicago; Broad Street, Chestnut and Walnut Streets, Philadelphia; Times Square and portions of Broadway and Fifth Avenue, New York.

*Class A.*—Parts of these same streets contiguous to the most congested sections; such as streets within the Loop, Chicago; Fifth Avenue, Pittsburgh; Broadway from 60th Street to 72d Street, New York; parts of Walnut, Twelfth and Market, Chestnut and Broad Streets, Philadelphia.

Class AA streets rarely exist outside the very largest cities of Grade I in the country.

Class A streets represent the most important streets in the usual city between 250,000 and 500,000 inhabitants of Grade II, and the White Ways of smaller cities. For instance, parts of Pennsylvania Avenue, Washington; Grand Avenue, Milwaukee; Main Street, Rochester; Seventh and Third Avenues, New York.

*Class B* streets are those probably greatest in number in all cities of any size in the country. These are well used, often have street railways on them, with wholesale or retail stores, and usually toward their farther ends develop into residence streets, for instance: Broad Street, Newark, and upper Broadway, New York.

*Class C* streets are streets of ordinary night use, except as they may lead to amusement centers or contain street-car lines. Examples are: Commonwealth Avenue, Boston; Park Avenue, New York; Michigan Avenue, Chicago.

*Class D* streets are usual residence streets of good quality throughout cities generally. In the larger cities the houses are in blocks of buildings, but in smaller cities this class of streets generally develops, even near the center, into

*Class E* or suburban residence streets with detached houses, and usually full of trees.

*Class F* streets, or special boulevards and parkways, have been developed of late by demands of more rapid transportation, which has been made possible by motor cars, and in this way the country has been brought in close contact with the city. Usually no street-car traffic exists on these roads and they are used almost exclusively by automobiles running at a speed of 20 miles an hour, or over. Examples of this are: the Shore Boulevard from Boston to Lynn,

the Ocean Parkway to Coney Island, the Parkway Systems of Chicago and Boston.

For the same reason, increased ability to travel at high speeds, these boulevard systems may be said to be further extending into cross-country, county, state and national highways which can be classified as *Class G* roads. Examples of this are certain roads in New Jersey: for instance, between Jersey City and Paterson; certain roads in Eastern New York; Nahant Road near Nahant, Mass.; Lincoln Highway between Jersey City and Newark, and the same highway in Salt Lake County, Utah. Comparatively little has yet been done in lighting such highways, but the prospect is encouraging.

Assuming that these grades of streets cover the general scale of street lighting, they will receive different amounts of lighting intensity, somewhat in accord with the necessities of vision, but the dominant factor is the amount of money devoted to street lighting by various municipalities. The question of appropriations really decides the type of lighting that can be planned for a given city, assuming always it is properly proportioned to the use of the respective streets. It appears that at present these appropriations are usually too small and the amount and intensity of lighting too low for the reason that within the last fifteen years automobile traffic has developed in its entirety, and the congestion in night centers has increased in proportion to the population and to the increase of transportation facilities. In this regard it is well to remember that while the development of better illuminating appliances and the demands for better lighting have increased the intensity of interior illumination probably five or six fold in the last fifteen years, general street illumination has increased but little.

#### PHENOMENA OF VISION

The faculty of vision ranges from full direct sensation from reflected light to what is termed adaptation to darkness, where we can distinguish only shades and contrasts. As you know, the retina of the eye receives light upon an arrangement of sensitive nerve termini known as rods and cones. In this arrangement the cones are rather at the center of the retina and the rods with scattered cones radiate toward the periphery. The cones are supposed to give us the sensations of color, and detail we have with direct vision by reflection, such as we get in daylight or under high artificial illumination. As the intensity of the light diminishes, the cones



begin to lose their sensibility, we slowly lose the sense of color, distinctness and so on, and our vision is restricted largely to the sensation given by the rods. These rods retain their sensitiveness; in fact, this sensitiveness really increases with darkness until in full adaptation it has become very acute. Be this as it may, however, rod vision is poor vision. In consequence, as Dr. Bell pointed out in the Johns Hopkins lectures of 1910, there is a physiological dividing line between that illumination by which we can see well and with ease, and one by which we can only see forms or contrasts and shadows. It is the first class of vision which requires the most expensive lighting, and which naturally we prefer; but, unfortunately, on account of insufficient appropriations, and so on, we generally have to deal with the lower grade of vision, and the difficulties in developing illumination of this class produce most of our problems.

Referring again to the grades of streets, direct vision, as in daylight, is required on Class AA streets and areas, and to a large degree on Class A and B streets, and particularly at intersections of streets of this character. Powerful lighting is necessary where street-car lines cross each other and turn in various directions, and where intermingling streams of pedestrians are persistent and continuous. Police statistics have shown that the greatest number of street accidents occur at places where traffic crosses or changes from one direction to another. In consequence, where such streets cross, each of them contributing streams of traffic, high illumination is required for safety if nothing else. If such lighting is provided in these places one has a degree of visual acuity approaching that of daylight, and feels the same sense of safety in that one can note the color, speed and detail of approaching objects and so direct one's movements as to avoid them.

Foreign cities have developed lighting which produces direct vision on their more important streets to a greater extent than in this country. We have few examples of lighting of the order of 1.25 foot-candles average horizontal measurement over a considerable length of street, as exists in London, nor have we any such examples of high illumination as is shown in the Potsdamer Platz, in Berlin, where an average of 1.75 foot-candles is developed over the entire Platz.

While the sense of vision varies with the individual, this direct vision by rods and cones together prevails down to about 0.1 foot-candle; below that we begin to get into rod vision, not entirely by any means at 0.05 foot-candle, but completely so at 0.01 foot-

candle. When low orders of intensity prevail in certain sections of a city and reliance must be placed on adaptation of the eye to a certain degree of darkness, it is well to avoid sudden changes to bright lighting within the section, as the eye adapts itself to such changes quite slowly. With this in view, we can approximate a scale of illumination for the various requirements of the grades of streets:

## REQUIREMENTS OF CITY LIGHTING FOR SEVERAL CLASSES OF STREETS

Grade of city	I 500,000 & over	II 250,000 & over	III 100,000 & over	IV under 100,000	Hor. foot candles	
	Grade of street				Average	Minimum
Degree of intensity						
High. Excess at street crossings	AA	AA	...	...	0.5	0.25
Giving clear vision.....	A	A	A	A	0.35	0.1
			White ways			
Lower but vision still distinct...	B	B	B	B	0.2	0.05
Above clear moonlight.....	C	C	C	C	0.075	0.02
About clear moonlight, average higher.....	D	D	D	D	0.04	0.01
Vision by silhouette or con- trast. Dark adaptation.....	E	E	E	E	0.02	0.003
Vision by silhouette or con- trast. Dark adaptation.....	F	F	F	...	From that of Classes D & E within a city to 0.01 for interurban roads.	
Vision by silhouette or con- trast. Dark adaptation.....	...	G	...	...	From directional light- ing merely to that of interurban roads.	

## CLASS AA.—FOREIGN STREETS AND PLACES—1913

	Horizontal foot-candles		
	Max.	Aver.	Min.
Cheapside, London.....	2.00	1.23	0.72
Regent Street, London.....	9.00	....	0.2
Piccadilly, Manchester.....	....	1.4	0.5
Freidrichsstrasse, Berlin.....	1.0	0.64	0.24
Potsdamer Platz, Berlin.....	7.6	1.75	0.12

The general question now arises as to how we are to produce the illumination required on the streets. Only a short time ago one of

our greatest problems was the fact that for practical use we had only two classes of lighting units; one, the larger unit, typified by an arc lamp; the other, the small unit, such as an incandescent or mantle gas lamp. It is obvious that it was impractical to properly grade the lighting just described with such limited means.

### ILLUMINANTS AND LAMPS

To-day there are two improved types of arc lamps, namely, the flaming arc lamps of two or three intensities; and the luminous arc lamps of three. In incandescent lamps we have now the complete system of gas-filled tungsten or "Mazda, Type C" lamps of practically any output desired for street lighting from 60 to 1500 candle-power, suitable for both multiple and series circuits. In gas lamps, the inverted mantle lamps with a variable number of mantles, and the vertical single mantle lamps are valuable and eminently practical.

In the brief time given to this lecture, it is impossible to cover older types of lamps, which are now superseded. As a matter of fact, the enclosed arc lamp and the vertical mantle gas lamp are and will be in general use for a long period undoubtedly, although they may be said to be superseded and obsolete.

Lamps as usually equipped for street purposes in standard forms may be described as follows, so far as concerns the light distribution.

The enclosed carbon arc lamp gives its maximum ray at about  $40^\circ$  from the vertical, the flaming arc lamp not enclosed gives its largest flux nearer the vertical, the enclosed type with standard equipments gives its maximum flux along and to about  $30^\circ$  from the horizontal, the luminous arc and the "Mazda Type C" along and usually below the horizontal at from  $10^\circ$  to  $30^\circ$  or  $40^\circ$ , depending on the equipment; inverted mantle gas lamps give their largest flux downward and around the vertical, and the vertical mantle lamp around the horizontal and downward.

### STREET LIGHTING WITH LARGE AND SMALL UNITS

In a lighting system with large units it is characteristic that when they are closely spaced the direction of the rays relatively is not as important as when spaced far apart, when such direction for promotion of perception has a decided effect in producing the necessary contrast. Where closely spaced the equipment would be such as to

give a distribution below the lamp approaching the hemispherical. An important characteristic in the case of arc lamps is that the light is usually white, either the violet white of the carbon arc, the clear white of the luminous arc, or the creamy or pinkish white of the usual flame arc. These light units scintillate, giving the effect of brilliance, vary in intensity and appear alive. The color effect produced is in contrast to the yellower light given from store windows and seems to belong characteristically to the street. This result is quite desirable.

Large incandescent lamp units equipped and spaced like arc lamps producing the same general effect as the large arc units of similar distribution characteristics, but giving a light tending toward yellow, are still and continuous in their performance and in consequence do not give the brilliant lively effect of the arc lamps. There is little differentiation in color with the light from store windows and, therefore, the street seems to take on the effect of one tone somewhat duller and more monotonous than with the arc system.

Lighting with small units spaced at distances proportionate to those for large units has the same characteristic of a lighted spot and a darker area. This was very familiar under the usual treatment of vertical single mantle gas lamps with their average candle-power and distribution. The substitution of electric lamps of much higher intensity broadened the scope of the small unit to a large extent. With lamps of from 80 to 100 candle-power at greater heights from the street, the illumination was much increased and brightened.

The effect of a number of smaller lamps on a block formerly lighted by two arcs, one at each end, was to break up the large dark area, decrease the extreme contrast between maximum and minimum intensity, and generally resulted in much greater visibility and safety. Where not too greatly diffused by enclosing glassware, care being taken to reduce glare, and arranged parallel or on one side of the street only, the contrast or unidirectional effect is maintained. Where strongly diffused, arranged opposite each other or staggered, and with relatively short spacing, the lighting loses contrast effect, and perception is affected detrimentally.

#### SOME FEATURES OF ILLUMINATION SYSTEMS OF ARC AND INCANDESCENT LAMPS

The lighting system now made possible by the use of various intensities in arc lamps and with "Type C" incandescent lamps, the

latter ranging in intensity from very high to low candle-powers, enables one to grade the lighting of streets as to their use, much more accurately than was possible in the past. The gas-filled incandescent lamps particularly are available practically on all systems of distribution, except that there are maintenance conditions which must be considered when they are used on the same circuits with arc lamps.

Lamps using the same current but of various intensities are available on any series system, so that we no longer have to provide special arc lamp circuits for the supply of current to large units. With this lamp we now have a series unit graded in consumption and intensity to meet all conditions necessary to fit the lighting to the street. They are economical and efficient, practically interchangeable, having no mechanical moving parts; are susceptible of artistic treatment and are in every way flexible and adaptable to street lighting conditions.

There is little question that the system of lighting with "Type C" lamps of all required sizes, will replace the direct and alternating current enclosed carbon arc lamp almost entirely, as soon as the equipment can be economically changed. It is also true that larger units will probably take the place of flaming arc lamps, in spite of the improvements that have been made in these lamps and their higher initial efficiency. It is unnecessary, therefore, to devote any particular time to the discussion of these types of lighting units. The formidable rival of the "Type C" lamp is the luminous arc which is somewhat more efficient. It is available in three current ratings, 4, 5, and 6 amp., with standard fixtures of several forms. It gives a very brilliant white and scintillating light of more accurate color value. It is also susceptible of ornamental treatment and by the use of refractors can meet conditions of almost any required spacing. Its high initial candle-power enables it to be widely diffused and yet develop strong lighting on the street. It is particularly practicable for business streets where not only the street but the building fronts should be well illuminated.

An advantageous feature of the magnetite arc lamp for street lighting is the brilliant white light it gives. A unit of this character is distinctive of the street itself, the light produced being in great contrast to that given by store lighting. Compared with incandescent lamps, the luminous arc lamp differs in that it operates mechanically, is limited to large units and cannot be used directly on alternating current circuits but requires the use of current rectifiers.

For the last year there has been a close rivalry between the two systems; both have definite characteristics which in specific problems will lead to a choice of one or the other. For the general requirements of illumination in the average city, however, it appears that the lower initial investment, when combined with the extreme adaptability, the ease of operation and satisfactory service performance of the "Type C" incandescent lamps, make them the more general choice.

In view of the availability of graded units of illumination, in both arc and incandescent lamps, the development of the lighting on the streets requires more careful adjustment than in the past, when we had only two units of illumination, one large and one small. One must also carefully study the development of such a graded system with reference to first cost as well as of operation.

One of the greatest obstacles to the improvement and increase of street lighting is the cost of the equipment and its installation on the streets; the most careful attention should be paid to this, and where it can be kept down without loss in appearance or in the efficiency of the illumination, it should be done. The utilization of present equipment so far as is possible to produce good results, will secure the greatest economy in first cost.

#### DEVELOPMENT OF ILLUMINATION ON THE STREET

Assuming the use of graded units, if we should use magnetite lamps for the large units, the circuits and locations of these lamps would naturally be in the central section of the city and on important radial streets leading therefrom, the smaller units of the gas-filled type would cover those portions directly enveloping the central section and the various residence and suburban districts with separate circuits therefor. In the simplest form, assuming that "Type C" unit alone is used, the general design of lighting the city would be about as follows: The various streets of the night center or centers, usually easily determined, would receive the most brilliant lighting from large units spaced regularly and closely along the streets. Special intersections, where streams of traffic meet and diverge, should be very adequately lighted with double lighting at the intersections and close spacing along streets. Where such intersections become open squares or plazas, excellent effects can be obtained from tall standards with lamps 40 to 45 feet from the ground. In such cases, with proper reflectors for throwing all the light below the horizontal, a high intensity can be obtained over the whole area.

The light need be diffused only slightly, if at all, and full efficiency can be obtained without danger of glare. It is in these sections of a city that one should see clearly by direct reflection. From this central section, avenues and streets will lead to the residence and other sections, and should receive the next lower grade of lighting, "B," amply sufficient for fast moving street-car or automobile traffic. This lighting may properly be so arranged as to be brightest nearest the centers and decrease to Class C as the distance increases and the traffic diminishes. This can be done most easily and cheaply by increasing the spacing between lamps, retaining at least one per street intersection. Where these streets intersect other streets of the same character, the lighting should be reinforced at the intersection. This grading of street lighting is further aided by the ability we now have to decrease the candle-power, and by the light-directing devices now available. Generally outside of the main night center of the city other local centers will be found much used at night, which must receive augmented lighting for a few blocks. In such cases the lighting should usually be sufficient to produce direct vision by reflection. As a general rule in business districts, the equipment should be of a type which will light the building fronts as well as the streets. In residence districts this should be avoided above the first story in sections where houses are in blocks, and further minimized in suburban districts. In the latter sections the average resident objects to almost any form of visible light source.

In every city will also be found the wholesale business and financial section which is usually deserted at night but requires ample lighting for police purposes, about Class C. As such sections are usually treeless they may best be lighted by large units at street intersections and alley entrances. Where blocks are short and mid-block alleys exist, mid-block lamps may be of a smaller size and with different equipment.

The residence sections of a city take varied treatment. In almost all cases, silhouette lighting must be depended on in these sections.

The density of population, the character of the houses, and the trees each has a strong effect in determining the lighting of residence streets. In the residence sections of the city where the houses are practically continuous, the illumination intensity should be maintained at about moonlight value—Class "D." As one leaves these sections, however, and reaches the suburban residence district, with detached houses becoming further and further apart, the lighting intensity would naturally diminish to Class "E." In this case where

trees are few in number, large lamps at street intersections placed fairly high, with directing refractors give good results and may be spaced at considerable distances without intermediate lamps. Where in suburbs the spacing can be moderately short, even more agreeable results may be obtained by the use of reflectors and diffusing globes. Where heavy foliage exists, small lamps at comparatively short distances apart on standards low enough to allow the light to spread under the trees gives the most satisfactory results to the residents.

In the suburban sections where overhead construction is usual, very satisfactory lighting can be obtained by the smaller incandescent units placed on each line pole or on every other line pole, due regard being had for the street intersections. If available, the use of the poles of other lines than those of the lighting company for street lamps in the residence district, would be valuable in such cases, particularly on those streets having trolley lines and acting as arteries or feeders leading from the outskirts to the center of the city.

In general, a low order of intensity may be used throughout suburban residence sections sufficient for police purposes, and yet fairly below the intensity of moonlight. Unidirectional lighting in such sections is particularly valuable as full use of the silhouette effect is necessary.

Boulevards may be treated like residence streets with either the large or the small unit. Where there is little interference with lighting and the boulevard is so wide that trees do not meet, and center suspension cannot be used for æsthetic reasons, large lamps on higher standards with long arms bring the light source well over the roadway and give excellent results. Where the reverse conditions prevail smaller lamps should be used. Where the boulevard is parked, smaller lamps attractively mounted and properly equipped give satisfactory results. If center plots are available, the boulevard being quite wide, the cheapest and most efficient lighting will be obtained by large lamps properly arranged in these plots. If the traffic is sufficient, and in any case at important intersections, the center plot lamps would properly be supplemented by lamps arranged along the outer lines of the roadways. When boulevards are extended and become interconnecting roads, passing temporarily from city conditions, the lighting must be graded in accordance with the amount of traffic. Originally lighted to the degree of "D" or "E" streets, they may change to Class "F" conditions, and the lighting be diminished accordingly with less expensive equipment.



Interconnecting country roads, county roads or highways, except within town limits, are rarely lighted at this time. A movement in this direction is beginning, however, and should be encouraged.

To make this type of lighting popular it must be very inexpensive in so far as equipment is concerned and low in operating cost. In consequence it usually consists of lamps mounted on line poles. These lamps are placed at distances varying from 300 to 900 feet and more apart. It is obvious that the lighting at such distances apart is largely directional in character. Four-ampere luminous arc lamps, from 600 to 900 feet apart, properly equipped with refractors and reflectors, give about the best lighting of this type in use at this time, and objects are quite visible in silhouette. This condition exists even up to spacing 1200 feet or 1500 feet apart. If the smaller incandescent lamps are used with refractors they should not be spaced at distances over 500 feet apart for the 100-c.p. size.

#### ELECTRICAL DISTRIBUTION SYSTEMS

In the lighting of streets, the electrical distribution system is important, from its bearing on the question of first cost and also of operation. Distribution systems can be generally stated to be either series or constant current systems, and multiple or constant potential systems, while combinations of these in one system are sometimes used. The second or multiple system, usually low tension, is generally limited to the central or business area of a city where the density of consumers is at the maximum. Energy for the lighting is taken directly from the general supply net work. Except in the largest cities this system is not generally in use for street lighting, and elsewhere the series system is practically universal. Originally it was used for open direct-current series arc lamps operating from arc-lighting generators. Speaking broadly, with the advent of the enclosed arc lamps came the alternating-current series circuits with series transformers, improved later by the constant current regulator, and then with the development of the luminous or magnetite lamp, came the mercury arc rectifier. To-day the alternating constant-current series system in one of its forms is used in most localities, as it is available for carbon or flaming arc-lamp circuits or "Type C" incandescent lamps and, with rectifiers, can be used for luminous arc lamps.

With this system the energy is distributed from central stations or sub-stations feeding the various circuits. Two methods seem to be

in use. In the first, constant-current regulating transformers change the constant-voltage alternating current to constant-current series alternating, being so regulated that the sizes of the lamps may be varied independently of each other. In the other, series transformers are used to supply the energy to the series circuit with special taps on the primary and secondary of these transformers for regulating the current within the limitations of the transformer, in accordance with the number of lamps on the circuit. In some systems a reactance is added in series with the lamp so that in case a lamp goes out, constant current will be maintained throughout the circuit. Each system has its advantages, particularly under special circumstances. The automatic regulation of the constant-current regulating transformer is more accurate and less awkward in adjustment than the series transformer system with taps. On account of the importance of the street lighting to the night life of a city, it is wise to have the lighting circuits originate at one point, as with the constant current regulator system, where it is under the observation of an attendant, as this would tend toward better operation and quicker repair in case of interruption to service.

So far as illumination is concerned, the question of the location of the lamps is relatively of great importance in the amount of expense that may attach to the first cost of the system, on account of the expense of lamp posts, their erection, and the connection of the lamps to the system. For instance, in overhead systems line poles can be used as lamp poles, particularly if at every street intersection there was at least one pole in a suitable position. This should be provided for in the construction of new lines. In such case the first cost of lighting units is at a minimum. The objections to overhead lines are the well-known ones of obstructions on sidewalks, ugliness and interference with trees. These objections may be greatly minimized if proper precautions are taken, careful preparations made, permits obtained in advance, the poles painted so as to be unobtrusive, and the structure maintained in first-class condition. The trimming of trees may also be accomplished if carefully negotiated, but it is best to conduct such operations with the authorities having jurisdiction, usually the Park Department of a city. Attention is drawn to these points for the reason that a part of the demand for underground construction and its consequent expense is caused by the use at times of somewhat arbitrary methods and the neglect of neat and workmanlike construction.

Where underground construction is warranted, or one is compelled

to use it, the question of equipment cost becomes even more important, the relative expense is greater and every effort should be made to utilize any available equipment and to locate the lamps so that the minimum expense be incurred. The cables, conduits, manholes, hand-hole boxes, street openings and settings and foundations of heavy iron poles involve a heavy first cost. Where iron trolley poles exist, as they usually do in downtown districts, very advantageous results can be obtained by utilizing them, with either the parallel or the staggered arrangement of lamps. By this sensible and economical method a number of quite successful installations have been made throughout the country, by which the street lighting has been greatly improved at a minimum cost.

Where underground construction must be extended into the outer sections of the city to avoid pole lines, armored cable may be used at much less expense than standard underground construction. Where iron lamp posts are available, such as in the substitution of electric lighting for gas lighting, they may be used to advantage, with modern diffusing appliances, in economy of first cost.

#### LOCATIONS, SPACING AND HEIGHT

This brings us naturally to the question of location, spacing and height of lighting units. A very careful study and survey of the streets to be lighted should be made before lamps are located, keeping in mind the kind of illumination to be used, the various grades of streets and the results to be obtained. Full field notes should be made covering the characteristics of each street, its use, character and direction of general traffic; the type and position of buildings, particularly of special buildings; the color, type and reflection characteristics of the pavement and buildings; curves in streets, alleys; parking, if any; special open areas along streets, special street intersections, and streets containing street-car lines, and particularly intersections of such streets. The existing lamp posts, distribution system, trolley poles and construction of pavements are also of great importance. These data should be transferred to a large street map for record.

So many different conditions may appear and the results desired are so varied, that it is impossible to lay down any general rule of procedure other than in the general description already given, except to emphasize the importance of studying the streets and designing the lighting in accordance with field conditions, even to the extent

of making trial installations in the most important places. A careful study of accurate field notes in connection with the general description of the laying out of lighting already given, will generally cause the situation to clear up and definite lines of procedure will develop.

If one had complete control of height, spacing and location of lamps, theoretically almost any desired lighting could be obtained, uniform or non-uniform, with minimum glare. Mr. Millar's tests for the National Electric Light Association and the Association of Edison Illuminating Companies, have shown that for visibility, uniform lighting on streets, particularly of a low order, is not the best, thereby exploding an old theory. In view of the results he has obtained, one should work toward lighting giving reasonable contrasts, that is, lighting which, predominating in one direction, creates contrasts. Such contrasts alternating between each light source thus create a moderate diversity of intensity between the extremes of uniformity and non-uniformity. We rarely have complete control of height and location, so that heights and spacing in actual practice must be considered. In general the height at which lamps are placed is limited by the expense of the equipment and the difficulties in getting at lamps at considerable heights for cleaning and renewal. From 20 to 25 ft. is the general limit for large units, and 10 to 16 ft. for the smaller ones. Within such limits, the higher the better, as wider light distribution is obtained, the high lighting under the lamp being decreased while the minimum normal illumination within the usual radius is only slightly affected. At these heights the larger lamps are generally out of the direct line of vision which, of course, is an advantage. It is rare to find large units at less than 18 ft. above the surface of the street except in ornamental and well diffused lighting systems.

Larger lamps can be used with the higher posts and in consequence there would be fewer posts. It will be noted that the generally available heights are limited within small variations, and hence the spacing is the dominant factor in determining the size of the unit with which the desired illumination is to be obtained. The limit of practical spacing where large lamps are used, has been somewhat increased lately by reason of the introduction of refractors which distribute the lighting flux at a further distance from the post. In certain cases, therefore, the distances between posts may be increased from that of older practice and the use of some intermediate lamps, with their extra installation cost, be avoided.

Concerning the relative effect of height and spacing on the horizontal illumination of the street within the usual working limits, it can be stated that with a spherical or uniform candle-power distribution curve below the horizontal, a change in height from 19.5 to 26 ft. will decrease the mean horizontal illumination by 14 per cent., and would increase the minimum illumination by 20 per cent.; whereas, assuming a fixed height, the mean horizontal illumination is practically inversely proportional to the distance from the lamp. The maximum, of course, varies very little as the spacing is increased. but the minimum decreases very rapidly, and in consequence the uniformity of the lighting becomes less and less.

Many arrangements of locating lamps on streets are in use, varying with their importance. Where large units are utilized on streets of ordinary use, such as C, D, and E, they are usually suspended at the center of street intersections, or on brackets from poles at such points. On more important streets, however, where center suspensions have many structural objections, lamps are usually placed on posts arranged in parallel along the curb, and staggered, or else placed parallel along the curb and opposite each other. This problem frequently comes up in connection with "White Way" lighting, and at times it is quite difficult to tell which is most desirable. As a matter of fact, parallel and opposite lamps do not give as uniform lighting along the center of the street, although similar in each space, as is given by the parallel and staggered arrangement. The arrangement of lamps opposite each other is usually admired for its symmetry of location, but it is more expensive than the usual arrangement. In general, except where artistic requirements dominate, the staggered location, except where closely spaced, is preferable. At street intersections under the parallel and opposite arrangement along any one street, lamps are not usually placed at street corners, but some little distance back from the house line, so located as to apply properly certain zones of light on the intersection from each of the units.

The parallel and opposite arrangement further requires that the intersecting street must be independently lighted and hence this system becomes more expensive in first cost and operation, so much so, in fact that it is rarely used on city streets except for display lighting or where trolley poles are available at small expense. The parallel and staggered system usually involves the use of two standards at each street intersection at diagonal corners, not exactly at the corners but approximately on the house lines. The intermediate

lamps are then placed alternately on opposite sides of the street at curb lines, the spacing depending on the intensity of lighting desired, length of block, location of alleys, and so on. With this arrangement the intersecting streets are taken care of, the intensity required obtained, and contrast and unidirectional lighting are maintained without the use of as many lamps and standards, and consequently at less expense in first and operating cost.

The position of the lamps, whether placed along the curb or suspended in the center of the street, has an effect on the general appearance of the street. Under the first type of lighting, the street appears narrower than under the second. Under metropolitan conditions, however, it would be very difficult to suspend lamps over the center of the street, and hence they are usually placed on the curb. A row of lamps opposite each other along the curb, or staggered along the curb, arranged regularly and carefully coördinated with the curb line as to height, distance from curb, and so on, both give the street more or less the same effect of parallel lines of light *along the curb*, with a long open field of vision, for at a little distance staggered lamps at night have about the same appearance as lamps placed opposite.

The theoretically desirable position for large units in the metropolitan districts would be suspended above the center of the street at a good height, using powerful lamps and varying the illumination intensity by closer or wider spacing. While this arrangement is realized abroad by suspension from the buildings or from posts on isles of safety, it is rarely possible in this country.

#### EFFECT OF PAVEMENTS AND BUILDINGS

The effect of lighting a city street of one of the higher classes depends very largely on the characteristics of the street, its pavements and its buildings, for in such streets it is usually desirable to light the building fronts. A straight street with light-colored smooth pavement, broad sidewalks, and buildings of a light color is most favorable to lighting, allowing long symmetrical lines of lamps, the light from which can be diffused, and which will be reflected specularly by the pavement and the buildings. A noteworthy instance of this, brought about by the coöperation of merchants and authorities, is Regent Street in London, which is lighted by powerful lamps giving white light erected on isles of safety in the center of the street. The street is paved with asphalt, has broad sidewalks, and the stores, which vary from 3 to 6 or 7 stories in

height, were by agreement painted a light color, the result being a brilliantly lighted and effective street, although there is little auxiliary window lighting. Pavements, as a matter of fact, have a greater influence in the appearance of a lighted street, than have buildings. Specular reflection from the pavement is very useful, particularly with lower grades of illumination where it is important to develop the silhouette effect. In most instances we see objects against the background of the pavement rather than against the buildings, particularly the more distant objects.

The lighter-colored the pavement the more the reflection obtained, the lighter the street appears, and the better the general effect. A given lighting system in a street with a dark dirty pavement, houses back from the street, would look dull and dim; whereas, under favorable conditions it would be entirely adequate. If municipal affairs could be so coördinated that the road surface would be always light in color the appearance of the streets at night would be improved and less intensity would be required to produce the desired effect.

#### GLARE

The blinding effect of glare is one of the most perplexing problems in illumination work. Practically it cannot be entirely eliminated; it occurs in daylight and even in moonlight. Its effects are almost independent of distance and it would seem that nature intended that the eye should be subjected to a certain amount of it.

With artificial lighting it can be relieved by removing the source from the line of vision by a considerable angle, say  $25^{\circ}$ . This result is accomplished by raising the lamp above the observer. Or, it can be relieved by enlarging the source of light by diffusing globes and large diffusing reflectors. Refractors are also used to deflect the rays from those angles near the line of vision. Little contrast between the source of illumination and its background also aids in reducing glare. Recent instances of these methods of minimizing glare for large units may be quoted:

One instance, three magnetite lamps with diffusing globes of some absorption are to be placed on the top of 30-ft. trolley poles.

A magnetite lamp is placed in a large sectional diffusing globe at 16 feet from the sidewalk.

In one case 1000-c.p. "Type C" lamps were placed in refractors for redirecting the rays, and suspended at a height of 30 feet above the street.

Another instance, 1000-c.p. or 1500-c.p., "Type C" lamps were equipped with band refractors and placed 15 feet above the street in large lanterns with diffusing glass.

With small units at low height and short spacings it is even more difficult to prevent glare; obviously the source of light is nearer the line of vision, yet the flux is small and if diffused too much becomes too weak to produce the lighting effect desired. With the "Type C" lamp, however, the small source of light is of such intense brightness that the light must be diffused, redirected, or the source raised as far as possible from the line of vision. In many cities, diffusing globes are placed around these lamps where they are used in connection with former gas lamp posts. In other cities, lamps of 100-c.p. are placed at intervals of from 24 to 15 feet in domed reflectors with the filament so focussed that one can only get the lessened glare effect of the large white disc of the reflector. This arrangement was found not to produce excessive glare. In another arrangement a 250-c.p. lamp was placed at a height of 16.5 feet with diffusing globe of low absorption value. In another instance, 100-c.p. lamps were placed in bowl refractors at a height of 15 ft. in attempting to prevent glare, but the effect was to make the lighting look dull. It is believed that an arrangement of a 100 c.p. lamp in reflectors with band refractors, the source of illumination being above the lower edge of the reflector and the bowl of the lamp being frosted, would give the brilliant effect of the bright light source without injurious glare.

#### ACCESSORIES

In one form or another, reflectors, refractors or diffusing globes are in general use on all lamps, for the reason that it is desired to redirect the rays of the lamp towards the surface to be illuminated. Diffusing globes are used often with reflectors where it is desired to throw most of the diffused light downward. Globes alone are used, sometimes of special design, where a part of the light is to be used in lighting the upper parts of the buildings. Reflectors should be carefully designed in connection with the lamp and the position of the light source, so that this source is at the proper focussing point in connection with the reflector for the light distribution desired. Where this is done, and with the addition of a diffusing globe in case of a light source of high intrinsic brilliancy, the effect of a large light source is obtained with fairly well distributed illumination. Where the sources of light are spaced far apart, refractors add much to



their effectiveness, the action of the refractor being to redirect the rays of light emitted by the light source into prescribed directions for which the refractor is designed, usually at from 10 to 15 degrees below the horizontal. This will increase the illumination midway between lamps, diminishing it near the lamps, thereby reducing the spot effect. Refractors, which have been in use abroad for a comparatively long time, came into use in this country with improvements of the luminous arc and the "Type C" lamp, in which the position of the light source does not vary.

### POSTS AND MOUNTINGS

Among the many other details necessary to successful street lighting, one must consider posts and mountings, particularly under city conditions, where the more simple standard apparatus, such as are used for overhead circuits on wooden poles, is not desirable except in so far as the lamp itself is concerned. It is necessary that the posts and mountings of lighting units should be as attractive as possible in appearance in the daytime; in any case they should be neat, well painted and workmanlike in effect, and kept so. Posts for metropolitan use are usually built of steel and iron, or iron and concrete, treated more or less ornamentally, and developed in many forms.

Lamps are supported on top of the posts, hung in lyre tops, or are placed in diffusing glass globes and in specially designed lanterns, for use either on pole tops or on brackets, and one or more brackets with a lamp on each bracket are often used. In all these forms, one of the principal considerations should be the ease with which the lamp can be reached for operation and maintenance. When lamps are set at from 22 to 25 ft. in height where pavements are smooth and traffic is dense, they are frequently attended to by men on tower wagons. As this plan is expensive, the lamps should be so arranged that they can be lowered to the street when possible to do so. Automatic hangers are frequently used; they have the advantage of detaching the lamp from the circuit while it is lowered to the street for attention.

The expense of the post and lantern itself varies over wide limits, depending on the elaboration of artistic design and finish. On metropolitan streets of the AA, A and B class, use is made of iron and steel posts, costing from \$35 to \$125 and above depending on the strength required, height and ornamentation. A full standard

and ornamental equipment for luminous arc lamps has been developed and used with good effect in many cities. The reinforced concrete post has proved to be serviceable and cheap. It is particularly adapted to artistic treatment at a minimum expense, and has been used with great success in parks and parkways particularly with the smaller lighting units. A very attractive post can be obtained for this service for about \$9. A successful attempt at a tall concrete post has recently been made in a Western city, where reinforced posts 30 ft. in height, with reinforced concrete brackets, have been constructed. Each of these posts with lamps cost about \$115 installed. With the exception of this one case, the estimates given above do not include the cost of setting, or of lamps. The cost of setting depends on variable conditions; with the larger and taller posts concrete foundations are used, and the necessary excavation under congested city conditions, is extremely costly in many cases. It is desirable, so far as is reasonable, to use standard designs of posts and lanterns, thereby avoiding excessive first cost. Where special posts and lanterns are designed for artistic effect, the first cost is largely increased and the operating costs also, for renewal parts have to be specially made and are expensive.

In general, where large units are employed, it is desirable to use brackets and bring them well out over the roadway of the street, in order to put the light where it is needed for the greatest traffic. With the ordinary foliage encountered on most avenues and streets in the central part of a city, long brackets will be found very desirable, with lamps at 20 ft. or higher, in order to bring the light out beyond the foliage. This arrangement also serves to place the lamps at a point where they not only light the roadway but throw a considerable portion of the light under the trees and on the sidewalk.

About the usual limit in length for big units under metropolitan conditions is from 8 to 10 ft. and in the suburbs where overhead construction can be used from 10 to 12 ft. In small units at heights of from 14 to 15 ft., 4-ft. brackets are quite sufficient to improve materially the lighting in the roadway and yet throw the light under the trees.

The housing of the light source itself; in other words, the lantern, must be weatherproof, designed for its type of lamp, to allow ease in repair, cleaning, and the renewal of glassware. It should be designed for the best light distribution and be attractive in appearance. The standard apparatus to-day generally meets these conditions. Special lanterns, like special posts, are expensive in first cost and

maintenance, and they are warranted only where artistic design is required to harmonize with that of the post. They are rarely justified except for points where great artistic merit is desired.

#### GRADED ILLUMINATION AND RESULTS ON CERTAIN STREETS

In establishing a certain grade of illumination on a street, a determination of the average and minimum illumination having been made, the size and number of lamps can be established quite easily by the flux method. Manufacturers now supply candle-power distribution curves of the complete unit, including globes, reflector or refractor. They show the spherical or hemispherical candle-power and the total or the downward useful lumens. From these data can be determined the number and size of lamps required per block or unit area to obtain the average foot-candles (lumens per square foot) desired. The location of the lamps must then be made after a study covering the many local factors that determine this. The locations should be finally checked by inspection, particularly on important streets where many factors may effect the desired result. With these points established, the minimum and maximum illumination can be determined usually by the point-to-point method.

When very low average illumination is to be established, the determination of the minimum illumination may be all that is necessary. Some typical installations illustrating the grades of street lighting given earlier in this lecture may be described as follows:

The so-called "Times Square" or "Longacre Square," New York, may be cited as a good example of an area where Class AA lighting is desirable. The "Square" is formed by the two triangles meeting at their apexes and extends from 43d to 46th Street. Two double-track street railways cross each other at an acute angle and great intersecting streams of traffic of street cars, motors, carriages and pedestrians occur until very late at night. A certain illumination is obtained until quite late from electric signs, etc., and from street lamps on the edge of the Square; we assume this to average 0.1 foot-candles, and that it was desired to bring up the average of the Square to 0.5 foot-candles. It is noted that the sidewalks around the Square are well lighted and the area over which the lighting is to be increased is in the middle beyond the sidewalks. Three ornamental poles, one placed at the apex near 46th Street, one near 44th Street, on an isle of safety, and one on the sidewalk at center near 43d Street, equipped with four brackets suspending the lamps at 45 ft., would be the best

height and location. Four lamps per post of about 1500 mean hemispherical candle-power each, so equipped with reflectors as to give about 9000 lumens within  $75^\circ$  from the vertical would produce the desired result. Auxiliary but smaller lamps would be placed on posts at 45th Street. This is the apex of each triangle and the large posts would be, respectively, 300 ft. to the north and 240 ft. and 560 ft. to the south of this point. A standard type of "Type C" lamp and pendant fixture with reflector will fill the requirements. At the height stated the glare is negligible.

A type of street of the A Class, which would be a "White Way" street in a smaller city, having an average illumination of about 0.35 foot-candles and a minimum of 0.15 would be equipped about as follows: On a street 50 ft. wide 4-amp. luminous arc lamps, one per post staggered and 65 ft. apart, 18 ft. high, with diffusing globe and high efficiency electrodes, would give 2500 lumens per lamp, which would produce the required average. Standard globes, mountings and posts can be obtained for this equipment.

Class "B" lighting would be produced on a street 95 ft. wide with 750-watt "Type C" lamps at 18.5 ft. from the ground, with standard lantern and diffusing globe, arranged staggered 100 ft. apart between streets and 60 ft. apart at street intersections, this arrangement giving by measurement an average of 0.25 foot-candle with a minimum of 0.044.

Class "C." This illumination can be obtained from 100 c.p. "Type C" lamps, 120 ft. apart on a street 45 ft. wide, lamps placed on poles along one side, 15 ft. in height, equipped with slightly coned, radial wave reflectors with filament of lamp carefully focussed in reflector, the resulting average illumination being 0.075, with a minimum of 0.015 foot-candle.

Class "D" lighting is about that needed for a boulevard street of high class with many trees. A very effective installation giving about this illumination would be one with 250-c.p. lamps in ornamental fixtures with reflector and diffusing globes, mounted about 15 ft. in height, placed parallel and opposite along a street 100 ft. wide and 110 ft. apart. Concrete posts like those in the Parkways of Chicago would be attractive in this case. Another method would be placing 150-c.p. lamps with light diffusing globes at a height of 14 ft., 110 ft. apart along the curb, staggered on a street 60 ft. wide.

Class "E" lighting is about that produced by the familiar vertical mantle gas lamp 9 ft. 10 in. high when in first-class condition, spaced 90 ft. apart, staggered on a street 60 ft. wide.

Class "F" intensities depend largely on the amount of money that can be devoted to them. The minimum is given for interurban conditions; it is very low and when within a city the illumination should be raised to Class "E" or "D." Such lighting as designated by "F" can be obtained with 400 c.p. "Type C" lamps with 80° refractors 22 ft. high, center suspension, 500 ft. apart.

Class "G" streets or country roads so far have been lighted mainly for directional effect only and have already been described.

It is well to note in connection with the general fashion of "White Way" lighting with its increased intensities over those of a few years ago, that such lighting has benefited only small portions of a city's streets and that the balance suffers from the appropriation of funds for this purpose only. Usually little effort has been made to improve properly the remaining lighting in the municipality since improved appliances became available.

It is necessary to explain that the intent of this lecture has been to cover briefly the utilitarian side of street lighting. The most attractive side, that of ornamental and artistic street lighting and fixtures, could not be touched on in the time allotted. However, it is proper to emphasize the desirability of such illumination, and while it is usually expensive and limited to certain streets in the larger cities, every effort should be made to attain it, even in more commonplace installations. A pleasing effect does not depend on expense alone, and good taste may be exercised with simple standard forms as well as with more expensive ones.

#### CONTRACTUAL RELATIONS

The increase and development of good street lighting depends to a very important extent on the contractual relations between the public utility and the municipality, and these relations should be coöperative, harmonious and progressive to develop this work to its full growth and usefulness which have not yet been attained. The provisions of a contract between the two parties should cover fully the complete illumination service, the equipment and investment necessary thereto, and the remuneration therefor. It should provide for the continuous production of a stated quantity of light at the points desired for certain hours in a given period of time, and also the service by which the quality of the illumination is maintained. It should also be flexible and provide for increases or decreases in number of units and changes in type of units and appurtenances with

the normal development of the art. The full details of such a contract cannot be given here. The legal form is usually provided by legal advisors of a city, and will embody the statutory or local legal requirements. The specifications covering the work of the lighting contractor should include the following requirements and conditions:

#### CONTRACT REQUIREMENTS

- I. General.*—(a) Equipment to be first-class, efficient and safe.  
(b) Contractor to be responsible for injury or damage and to indemnify the city against patent infringements.  
(c) Contractor to exercise skill and foresight in carrying out the provisions of the contract.

*II. Work to be Performed.*—(a) Requires the furnishing of all lamps, supports, connections, appurtenances, electric energy, repairs and all service for operation and maintenance.

(b) States the respective numbers of each size and kind of lamp to be furnished at the beginning of the contract, including technical description of the same with its equipment and operating supplies, if any. The rated energy and illumination performance when properly operated to be described and submitted.

(c) States the respective lamps to be supplied with energy from underground and from overhead circuits, with the type and method of support. A list of locations should be furnished, preferably with a map indicating the kind of service connection and support.

(d) As the locations and kind of supports are usually prescribed or approved by the city, this clause would provide for submitting the necessary samples, photographs or maps to the city within a specified time and getting its approval of these items.

*III. Operation.*—Recites the conditions of the operation and maintenance of the lamps and all their appurtenances, practically covering the lighting service, including the uniformity of lighting, elements of the same, regulation, trimming or replacement, cleaning, painting and prompt repairs. This clause should require complete operation in accordance with the best modern practice.

*IV. Testing.*—Should cover the tests to be made by city of the fulfilment of the contract requirements as to the light given by the unit. This is usually required either in the terms of energy or illumination or both; tests to be made either on the streets or in the laboratories or both. This would usually be accompanied by clauses covering the quality of service and inspection thereof.

*V. Increase or Decrease in Number of Lamps.*—(a) In case of additional lamps, would require compliance with previous specifications as to type of supports, connections, lamp units and so on, and locations as specified by the city.

(b) Should cover the installation of additional lamps and damage and allowance for delay.

(c) Would cover limitations as to distance of extensions from the present circuits on either the underground or the overhead circuits, without cost to the city. Would also cover the payment by the city if the lamps are placed at distances greater than the limits agreed upon.

(d) Defines the right of the city to discontinue lamps entirely or change from overhead to underground circuits, depending on the rates for the lamps on each circuit or with provisions for refunding to the company the unamortized cost of the equipment.

(e) Would state the conditions in long-term contracts as to the lamps and equipment ordered late in the life of the contract and the unamortized cost of the same toward the end of the contract term, if it was not renewed.

(f) Requirements to be stated covering deductions as liquidated damages for outages.

(g) Provision covering arrangements by which another type of improved lamp may be tried and adopted if desirable to both parties. This clause would also provide method of estimating the cost of such change relative to the cost of the original equipment.

(h) Provision should be made for covering arbitration of disputes between the parties to the contract, or of amendments to the contract.

(i) Conditions to be stated covering payments by the city under the contract in accordance with the local statutes governing this process.

It will be understood that this list of contract provisions is general and will require considerable amplification and change in many instances. It is understood, of course, that every contract stands on its own bottom and no general rules can be laid down to cover local policies and conditions.

#### PRESENT PRACTICE IN CONTRACTS

When one considers the many varied circumstances that have existed in the development of the electric lighting industry since its

inception and the various political forms of government under which contracts have been made, it is not strange that these contracts vary very much in certain provisions, and that no standard form seems to exist, even at this late date. It is interesting therefore to observe the data obtained by an inquiry on this subject and others, instituted by The Milwaukee Electric Railway and Light Company in 1915. Through the courtesy of the company a partial summary of it can be submitted to you, the limited time requiring that only the most important and usually disputed points be touched on.

It might be deduced from the data collected that contracts were divided into two great classes depending on the theory on which the contract is based. One class obviates specific clauses covering removals, changes of equipment, types of units, etc., by providing a margin or factor of safety in its rates to generally cover these points. The other class takes up special charges in detail and provides for them specifically outside of the rates for the illumination service itself. Data were obtained from about 128 different companies in cities varying from 20,000 to over 200,000 in population, but omit Chicago, Philadelphia, and portions of Greater New York.

From the data it appears that the length of term of contract

In 21	cases	was	under	5	years	
In 44	"	"		5	"	
In 7	"	"	over	5	"	and under 10
In 48	"	"		10	"	
In 4	"	"	over	10	"	
In 4	"		there	was	no	contract.

As to the question of the right of a city to increase the number of lamps, there was no restriction in 96 cases. As to the right of removing lamps from one location to another, there was no restriction, except that in a little more than half the cases the companies bore all the costs, while in the balance the city generally paid the costs.

As to ordering lamps changed from overhead to underground circuits, in over half the cases the city had no right to do so. In 39 cases the city had the right, but it was rare that the company was remunerated for such change.

No provision was made for tests of illumination or energy in 58 cases, nearly half the total number. In 34 cases the city may test; in the majority of these cases the tests were for energy consumption only.

Referring to the distance of the location of a new lamp from the



nearest circuit, it was found in 72 cases that there were no limits. In 49 cases it was limited by various distances. Where the distance to the location of the new lamp exceeds the limit, in 36 cases no provision was made to cover excess cost, but in 20 cases the city paid the cost for the excess distance.

The discontinuance of lamps is allowed to a minimum number in 45 cities; in 35 cities the city may discontinue as much as it pleases, in 22 cases no provision is made, and in 11 cases discontinuance of lamps is not allowed at all.

Provisions for substitution of improved lamps are found in the contracts of only 29 cities. In 27 of these, the conditions on which such changes may be made vary from no additional charge to the full cost in excess of the original contract requirements.

Outage regulations and penalties are enforced in only 40 cities.

Contracts are subject to revision as to price by agreement in 14 cities.

Contract rates are subject to regulation and amendment by national, state and municipal authorities as follows:

- In 18 cases by the municipality.
- In 55 cases by public service commissions.
- In 5 cases by the state authorities.
- In 4 cases by the state and municipal authorities.
- In 1 case by Congress.

The queries just mentioned are those which might cause more or less serious disputes between the parties to a street-lighting contract, and this extremely wide variation in practice is difficult to explain. It certainly shows a state of looseness in contracts which under usual business conditions would produce needless disputes, but this generally does not seem to have been the case.

#### MEASURE OF ILLUMINATION SERVICE

Among the most frequently discussed questions in contract requirements is that of a satisfactory measure of the illumination service rendered to the city. It is a complicated matter and from the municipal standpoint in actual practice should be handled on administrative engineering lines based on correct technical data.

Good illumination service implies two things. One is a satisfactory light-giving source, and the other is the attention given to it or the service which keeps the source of illumination at its maximum efficiency, and provides for its continuous and regular opera-

tion. These two should be taken together in measuring the result.

The older types of lighting units such as the carbon arc lamp varied and were irregular in intensity, so that much difficulty was encountered in establishing a satisfactory measure of illumination. It was very difficult, if at all practical, to transport the units to the laboratories and duplicate street conditions. It was also difficult to handle smaller and fragile units, such as mantle gas or vacuum tungsten lamps. The more modern illuminants are comparatively rugged, vary little in actual operation and may be tested with greater ease and more definite results. A satisfactory specification can now be drawn covering such lighting units as the luminous arc or the "Type C" incandescent lamp, either of which, with specific equipment, will develop a predetermined distribution of intensity from the light source when a specific amount of energy is delivered at the lamp and the variations of this may be fixed within close limits with modern regulating appliances. A diagram showing the candle-power distribution with the mean spherical candle-power and the flux data for a given lamp and equipment should be required and this from time to time may be used as a check on the fulfillment of the contract.

On the usual series circuits a simple system of recording ammeters operated and owned by the city would check the energy used daily and a reasonable inspection force can determine whether other service conditions were fulfilled. With limiting requirements as to the economical life of incandescent lamps, in view of loss in candle-power, inexpensive street or laboratory tests by the nearest university or laboratory, on units taken at random, would afford a practical check on the illumination service rendered and be within the means of almost any city spending a reasonable sum for its lighting. In large cities, involving various types of units and service, an elaboration of this system with the aid of a testing laboratory would accomplish satisfactory results. In such cases the inspection service becomes even more important, as usually in such cities there are a number of light sources which vary largely in accordance with the attention given them, such as mantle gas lamps. These vary from so many causes that the inspection of the results of the attention given to the unit and service given by it is most important, for the illumination shown by tests of these lamps on the street varies within a considerable percentage even when they are well maintained.

## UTILIZATION OF IMPROVEMENTS

Another important provision of a lighting contract of any length is a clause providing a means of utilizing improved lighting appliances.

General dissatisfaction will occur when the people of one city see in other cities considerable improvements in lighting which they cannot have on account of unsatisfactory contract conditions. It is wise public policy, therefore, for many reasons to include in a long-term contract a clause which will allow for the trial and possible substitution of improvements in lighting units and adjustments of costs. Such a clause should provide for a thorough service trial and conservative methods of change; for if lighting systems had been changed as rapidly as the successive leading improvements have taken place in the past few years, a heavy financial loss would have ensued.

You will note from the statistics already given of the length of term of contracts, that 103 out of 128 were for 5 years or over in length. This is due undoubtedly to the general business advantages of long-term contracts. Formerly there was little if any possible revision during the term of the contract, but conditions have changed. A large number of these contracts are now subject to possible revision as to rates or improvements during the life of the contract, a few by provisions of the contract itself, the larger number by public service commissions which on their own initiative, or on request by the city, may investigate and revise certain contract conditions.

## STATE CONTROL OF CONTRACTS AND EFFECT

State control of public utilities has a decided effect on contracts for street lighting. With well-administered companies it removes possible competition. Such a company normally, therefore, will continue to perform the street-lighting service and its equipment therefore will be available for its whole economic or useful life. To this extent, therefore, the former value of a long-term contract is lessened.

Rates for street lighting have also been affected. Where this question has been investigated by public service commissions the trend of their decisions generally follows the theory of cost of service with a reasonable rate of return. In many cases they have obtained the approved contract rate through an inventory and cost apportionment precisely similar in method to that used in establishing rates for commercial business.

Generally this has been done without allowing any marked discrimination in favor of a municipality. Free service particularly is condemned and is apportioned as part of the cost of street lighting. The commissions rarely interfere, however, in a street-lighting contract so long as its terms are reasonable and encourage a practical and liberal policy of adjustment during the life of the contract. They usually allow rates for energy lower than published tariff rates for various reasons, among them being the facts that the city is a single customer, generally requires no meters, contracts for long periods, and its uses of energy develop a favorable load-factor.

Apparently, therefore, the question of rates for street lighting in the future under public service commissions, will tend toward cost of service plus a reasonable return, both of which depend to a certain degree on the size and length of the contract, the service required, and the general business of the company in the community in which it operates. The most advanced form of a contract based on cost and return is that which has been recently adopted in the state of Wisconsin and known as the "Indeterminate Contract." This has been fully described in the technical literature of the day. In brief, it is a contract where the company becomes the agent of the city, carrying out its wishes at cost and receiving for its remuneration, in addition to all costs including amortization of equipment, only a reasonable return on the business involved. The initial investment basis and rate of return is established by agreement or by a decision of the Public Service Commission and the items of all accounts are rendered to the city yearly. This form of contract should encourage the use of higher intensities of illumination, for under it a larger illuminant may be used in place of a smaller one with a relatively small increase of the cost of the service.

#### REDUCTION OF COST AND INCREASE IN USE OF LIGHT

Summing up the situation, it may be said that the general trend of the various factors bearing on rates for street lighting, such as improved and more efficient units and state control, is toward low rates. This in itself encourages a more liberal use of street lamps and better lighting. This greater volume of business tends to offset the lower return per unit.

There is a large field of needed improvement in street lighting in this country, not only in the normal increase in numbers of lamps but in the increased intensity really required by modern condi-

tions. Its development may be greatly accelerated when costs are decreasing, and a wise business policy will urge the advantages of improved lighting where favorable prices occur.

### GOOD PUBLIC POLICY

A careful far-seeing public policy, after providing for good service with all that that requires, will proceed to the education of the public in the possibilities of the illumination of the city and the ability of the contractor to furnish such illumination at reasonable rates.

This function naturally devolves on the public utility. With this in view, it is not enough to restrict one's efforts to the requirements of the day. The relations between the city and company should be such as to make it possible for the company to show the city the improvements in the art as they occur, and to explain how the city can best use its available funds in the increase and improvement of the street lighting so as to attract people and business to it. This effort should be continuous and of the same general persistence used for commercial customers, and the utility should remember that it has a dual responsibility in the improvement and welfare of the city, for what helps the city helps the company.

Even if this were done without profit or with a relatively low rate of return, the effort would be justified from the increased business derived from the general improvement. It is difficult to imagine a better method for the advancement of street illumination or for retaining the good will of a community.

## RAILWAY CAR LIGHTING

BY GEORGE H. HULSE

The proper lighting of railway cars has always offered special problems, both in regard to the methods employed in producing the energy for lighting, and in the application of the light sources to obtain proper illumination.

As methods of lighting have been improved, the new methods have been applied to the lighting of cars with such modifications as the special conditions make necessary. Oil lighting superseded candles, gas displaced oil lighting, and for a time completely dominated the field, but at the present time, as in other places, the field is divided between gas and electricity.

### GAS LIGHTING

Practically all cars using gas light employ oil gas as the illuminant. As the storage space available is limited, it is necessary to carry the gas under pressure in order to have a sufficient supply on the car, and also to have a gas of comparatively high illuminating value. Coal gas, of low candle-power primarily, loses at least 50 per cent. of its illuminating value when compressed to a point high enough to give sufficient storage. Oil gas has not only a much higher candle-power uncompressed, but when compressed to ten atmospheres, loses only 10 per cent. of its illuminating power.

Oil gas is made by the distillation, or "cracking" of petroleum oil in cast iron or clay retorts, or in steel generators filled with fire brick checker work. A fixed gas is formed which has for its principal ingredients methane and heavy illuminants with a very small amount of hydrogen. It has a heating value when compressed of 1250 heat units per cubic foot. After passing through proper washing and purifying apparatus, the gas is compressed to 12 atmospheres in store holders, from which it is carried to the railroad yards by suitable pipe lines. The car holders are filled from these pipe lines. The car equipment (see Fig. 1) consists of one or more welded steel holders to contain the gas supply, two filling valves, a pressure gauge, a regulator for reducing the holder pressure to that at

which the lamps operate, the pipe line for carrying the gas from the holders to the lamps, and the lamps or burners. All fittings for both the low-pressure and high-pressure piping are especially designed for the work. The pressure regulator is placed under the car near the holders so that the amount of high-pressure piping is small and none of it is inside the car.

The pressure regulator reduces to the proper pressure and maintains this pressure constant with the varying amounts of gas used.

At the beginning oil gas was burned in regenerative lamps with a cluster of from two to four burners of the union jet type. All lamps used at the present time are fitted with incandescent mantles.

One of the early, and probably the earliest completely successful application of the inverted mantle was to car lighting. This was

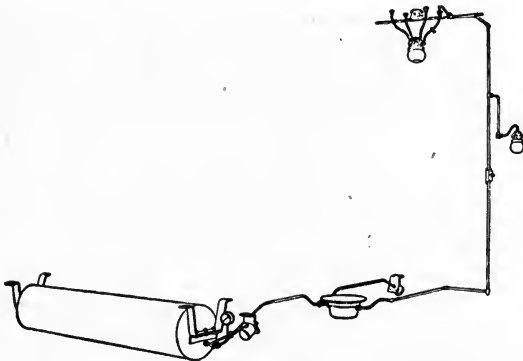

Fig. 1.—Diagram of Pintsch gas equipment using mantle lamps.

due to the fact that while the development of the inverted mantle for general use had to contend with low and varying pressure, in car lighting a sufficient and uniform pressure was at all times available.

In this country two sizes of mantle are used, one which gives 28 candle-power, with a gas consumption of 0.8 cubic feet per hour, the gas pressure being 1 pound per square inch. The use of this size mantle is limited to bracket lamps, and a few installations in which four of these mantles are employed in a cluster for center lighting.

The other size of mantle, which is used for center lamps gives 90 candle-power, with a gas consumption of 2 cubic feet per hour at 2 pounds pressure per square inch.

The mantles used are of a special form and composition to with-

stand the rigors of railway service, and give three months average life in service.

There are upward of 85 gas plants for the manufacture of oil gas in the United States and Canada. Gas is delivered to the car holders and charged for at a uniform rate, the amount of gas supplied being measured by the increase of gauge pressure.

The holders are made exact size and the contents of a holder can always be determined by multiplying its capacity by the gauge pressure in atmospheres. This feature, besides furnishing a means of measuring the amount of gas supplied, is important for determining the hours of lighting which a holder contains and also for the purpose of car interchange.

Cars using oil gas are dependent upon stationary plants, but this has not been found to be a disadvantage, principally because the time required to charge a car is so short. It can be done, if necessary, at a division station stop.

### ELECTRIC LIGHTING

Three methods of electric lighting for railway cars are in use:

1. The head-end system.
2. Straight storage.
3. Axle-driven generators.

*The Head-end System.*—In the head-end system use is made of a generator driven by a steam engine at the head of the train, either in the baggage car or on the locomotive. Electrical energy is carried back from the generator to the cars to be lighted by means of a train line on the car roof and connectors between the cars.

In this country the generator of a head-end system is usually installed in the baggage car, and is driven by a steam turbine, steam for its operation being brought from the locomotive through suitable hose connections. A very few equipments are in service with the generating set mounted on the locomotive, but this entails heavy installation cost, since several locomotives may be used in hauling one train over its trip.

As the steam supply is shut off when the locomotive is detached from the train it is necessary to have a storage battery on one of more of the cars to supply light during such time as the locomotive is detached at terminals or division points.

The head-end system gives efficient and economical results, but



its great disadvantage is that light can only be used when a car is in a train with a generator equipment. If the cars are equipped with batteries to supply light during such times as the locomotive is disconnected, the proper arrangements for charging the batteries entail a sacrifice of simplicity and economy.

*Straight Storage.*—In the straight storage system each car is equipped with a set of storage batteries of sufficient capacity to supply energy to the lamps for the desired trip. As ordinarily applied, the equipment is simple, consisting of lamps, storage batteries and charging receptacles, with necessary wiring. At terminal yards the batteries are charged with energy obtained from a stationary power plant. The lamps operate directly from the batteries, no voltage regulator being used.

This system of lighting would be ideal if it were not for the fact that the charging of the batteries consumes too much time. Generally cars are not available in one location long enough to receive proper charge.

The cost of equipping a railroad yard with the proper charging lines is considerable.

Car lighting systems dependent upon stationary plants are feasible as shown by the oil gas system, but the time required for charging must not interfere with car service.

*Axle Driven Generators.*—In this system the car axle is used to drive a generator which supplies energy for the lamps in the car, and for charging a storage battery which supplies energy to the lamps when the car is running below a certain speed.

The equipment consists of the following:

A generator mounted either on the car body or truck with some form of driving system between the car axle and the generator, a storage battery to maintain the light when the speed of the generator falls below that at which it gives the proper voltage, regulating apparatus to govern the output of the generator at varying speeds, to give the proper charge to the storage battery, and to maintain constant voltage at the lamps, and some means of keeping the polarity of the battery charging current constant when the direction of the movement of the car is reversed.

Various systems have been devised to meet these conditions and a large number are in successful operation on railway cars. The best practice is exemplified by an equipment in which the generator is mounted on the car underframe, the generator controlled for output at varying speeds by a carbon pile rheostat in its field circuit,

which give a constant current output until the battery approaches full charge, when the control is automatically changed to constant voltage, thereby preventing overcharge of the battery. The voltage at the lamps is held constant by an automatic carbon pile rheostat placed between the battery and the lamps.

Of the three different systems of electric car lighting, the axle-driven generator system is and, no doubt, will continue to be the one most used. This system renders the car absolutely independent of a stationary plant and, in spite of its seeming complexity, is the only one of the three systems capable of general application to cars. A properly designed axle system is superior to head-end or straight storage system as it renders the car available for use in any territory and does not necessitate lay-overs at charging plants.

### CAR ILLUMINATION

Adequate and proper illumination of passenger cars of various types presents difficulties not met with in other lines of illuminating engineering. Car construction limits to a considerable extent the location of the lighting fixtures, which, in combination with the seating arrangements makes ideal illumination conditions hard to realize. It is practically impossible to have the lighting fixtures out of the range of vision, and very adequate screening of the light source is necessary. In addition to this the constant motion of the car makes it necessary to have a greater amount of illumination than is required in places where this condition does not exist.

There has been in the past a tendency to sacrifice proper illumination results in favor of the appearance of lighting fixtures, and also to look for an appearance of light in the car, rather than for proper illumination; but these mistakes are rapidly being corrected, and I believe that the practice of proper illumination has advanced as far in car lighting as in any other fields.

*Passenger Coaches.*—The passenger coach is the type of car that is used in greatest numbers, and its proper lighting is most important. It is the dividend paying car, and carries the great bulk of the traveling public.

Aside from the general illumination necessary, the principal use of artificial illumination in a coach is for reading, and the lighting system should be so designed as to give proper illumination on the reading plane, which is  $45^{\circ}$  to the horizontal and at right angles to the center line of the car.

Owing to car design and construction, two methods of lighting are available, as regards the placing of the lamps. They may be hung from the roof in a single row down the center line of the car, or a row may be placed on each side deck, directly over the seats. An

DATA ON ILLUMINATION EFFICIENCY AND UNIFORMITY TEST No. 63

ILLUMINATION 33 IN. ABOVE FLOOR OF CAR

	AVERAGE FOOT CANDLES				
	Window Seats	Aisle Seats	Mean on seats	Aisle Gals.	Centre Car
45° reading plane	3.72	3.65	3.69		
Horizontal plane			4.63	4.90	4.68
Per cent. of total light delivered on horizontal plane.....	34.0%				
Mean variation from average, 45° reading plane.....	13.3%				
Lowest four values (excluding station 20), 45° reading plane.....	2.50 f.c. 2.60 f.c. 3.20 f.c. 3.32 f.c.				

GAS LIGHTING  
 CENTER DECK 2 SEAT SPACING  
 Type of Car 70 ft COACH  
 Description of Unit Prismatic  
 Reflector Bowl-Envelope  
 Safety Co. No. 1812 6687  
 with Fungsten Lamps  
 Base Contact of Electric Lamp  
 above top of  
 Screening Angle of Reflector ~  
 Coefficient of Reflector of car head-  
 lining = 26.3%

LIGHT OUTPUT OF ONE UNIT  
 Total light, lamp alone: = 780 lumens  
 Lamp with reflector:—  
 Distribution..... 100° to 180° = 64.2 lumens  
 50° to 100° = 236.5 lumens  
 0° to 50° = 294.2 lumens  
 Total = 594.9 lumens

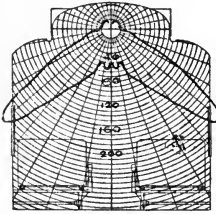

Generated lumens per running foot of car = 130 lumens

	C. P.	C. P.	C. P.
0°	55.2	65° 49.4	125° 12.9
5°	66.0	75° 17.5	135° 12.7
15°	56.1	85° 13.3	145° 11.5
25°	64.2	90° 13.5	155° 9.6
35°	116.0	95° 13.6	165° 5.6
45°	208.0	105° 14.8	175°
55°	156.0	115° 13.9	180°

ILLUMINATION CURVE 45° READING PLANE  
 Aisle seat illumination shown by full line Window seat illumination shown by dotted line  
 For Car Plan and Test Station Locations see plan No. 1  
 Copyright 1914 by the Assoc. of Ry. Elec. Engrs.

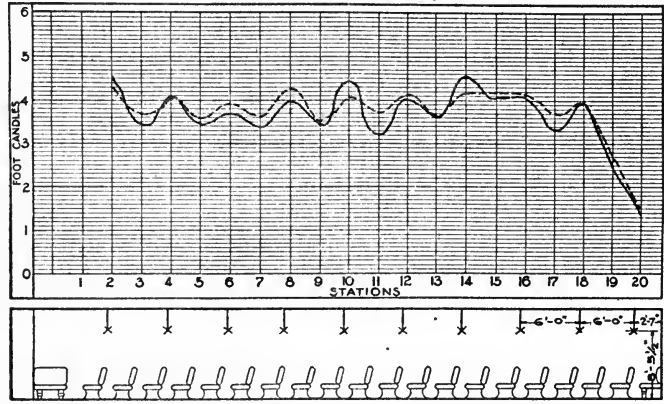

Fig. 2.—Illumination results in coach with gas mantle center lamps.

elaborate series of tests made a short time ago demonstrated that equally good illumination results can be obtained with either type of installation. Practical considerations, however, make for center lighting on account of the fewer number of fixtures used and the lesser number of lamps and reflectors to maintain. Another con-

sideration is that with side lighting shadows are likely to be cast by a passenger's head which will interfere with the proper illumination of his own or another person's paper. This occurs with center lighting only when people are standing in the aisles.

TEST No. 31  
**DATA ON ILLUMINATION EFFICIENCY AND UNIFORMITY**

ILLUMINATION 33 IN. ABOVE FLOOR OF CAR

	AVERAGE FOOT CANDLES				
	Window Seats	Aisle Seats	Mess on Seats	Aisle Only	Entire Car
45° reading plane	1.73	2.09	1.92		
Horizontal plane			2.61	2.29	2.55

Per cent. of total light delivered on horizontal plane..... 58.9%  
 Mean variation from average, 45° reading plane..... 11.0%  
 Lowest four values (excluding station 20), 45° reading plane.....  
 1.50 f.c. 1.59 f.c. 1.68 f.c. 1.59 f.c.

**ELECTRIC LIGHTING**  
 CENTER DUCK 2 SEAT SPACING  
 Type of Car 70 ft coach  
 Description of Unit Prismatic Reflector-Bowl Unit  
Holophane Wks. No. 18310  
50 watt G-30 Tungsten Lamps  
 Base Contact of Electric Lamp 1/16  
 above top of REFLECTOR  
 Screening Angle of Reflector.....  
 Coefficient of Reflector of car headlining = 26.3%

**LIGHT OUTPUT OF ONE UNIT**  
 Total light, lamp alone:..... 400 lumens  
 Lamp with reflector:—  
 Distribution..... 100° to 180° = 54.1 lumens  
 50° to 100° = 71.0 lumens  
 0° to 50° = 162.8 lumens  
 Total = 294.9 lumens  
 Generated lumens per running foot of car = 66 2/3 lumens

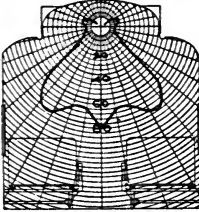

	C. P.		C. P.		C. P.	
0°	85.6	65°	12.1	125°	13.9	
5°	76.6	75°	10.8	135°	9.4	
15°	69.8	85°	11.1	145°	4.4	
25°	79.0	90°	11.3	155°		
35°	84.1	95°	12.9	165°		
45°	68.9	105°	14.9	175°		
55°	23.7	115°	15.9	180°		

ILLUMINATION CURVE 45° READING PLANE  
 Aisle seat illumination shown by full line Window seat illumination shown by dotted line  
 For Car Plan and Test Station Locations see plan No. 1  
 Copyright 1914 by the Assoc. of Ry. Elec. Engrs.

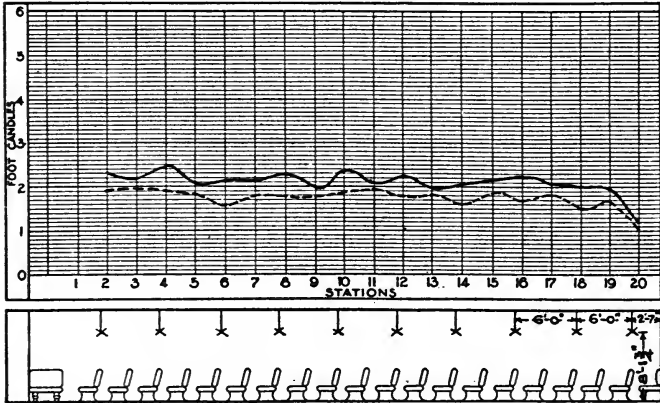

Fig. 3.—Illumination results in coach with electric center lamps, enclosing bowl type.

The following are some of the results obtained in the test of which I spoke above:

Fig. 2 shows results obtained with center lamps using Pintsch gas, with mantle. The reflector unit is a prismatic reflector having a prismatic bowl under it to give proper light distribution. The

prismatic reflector is covered on the outside by an opal-glass envelope, adding to the appearance and serving to keep the prismatic glass clean. This arrangement gives very uniform lighting; the illumination of the aisle and window sittings being practically equal.

TEST No. 7  
**DATA ON ILLUMINATION EFFICIENCY AND UNIFORMITY**

	ILLUMINATION 33 IN. ABOVE FLOOR OF CAR				
	AVERAGE FOOT CANDLES				
	Window Seats	Aisle Seats	Meas on Seats	Aisle Only	Entire Car
45° reading plane	1.99	2.61	2.30		
Horizontal plane				3.08	3.30
Per cent of total light delivered on horizontal plane.....	46.7%				
Mean variation from average, 45° reading plane.....	16.0%				
Lowest four values (excluding station 20), 45° reading plane.....	1.72 f.c. 2.03 f.c. 2.03 f.c. 2.05 f.c.				

**ELECTRIC LIGHTING**  
 CENTER DECK 2 SEAT SPACING  
 Type of Car 70 ft Coach  
 Description of Unit Clear  
 Prismatic Reflector  
Holophane No. 18226  
50 watt G-30 Tungsten Lamps  
 Base Contact of Electric Lamp 1/8"  
 above top of REFLECTOR  
 Screening Angle of Reflector 33°  
 Coefficient of Reflector of car head-  
 lining = 26.3%

**LIGHT OUTPUT OF ONE UNIT**  
 Total light, lamp alone = 400 lumens  
 Lamp with reflector:—  
 Distribution.....100° to 180° = 56.4 lumens  
 50° to 100° = 72.4 lumens  
 0° to 50° = 219.7 lumens  
 Total = 348.5 lumens

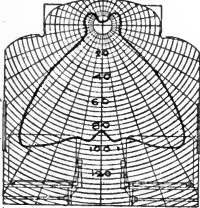

Generated lumens per running foot of car = 667 2/3 lumens

	C. P.		C. P.		C. P.	
0°	85.5	65°	13.7	125°	14.0	
5°	92.5	75°	14.9	135°	11.4	
15°	94.5	85°	14.4	145°	7.4	
25°	108.0	90°	14.0	155°	3.0	
35°	118.0	95°	13.5	165°	2.9	
45°	71.7	105°	13.7	175°	2.9	
55°	15.2	115°	14.4	180°	3.1	

ILLUMINATION CURVE 45° READING PLANE  
 Aisle seat illumination shown by full line Window seat illumination shown by dotted line  
 For Car Plan and Test Station Locations see plan No. 1  
 Copyright 1914 by the Assoc. of Ry. Elec. Engrs.

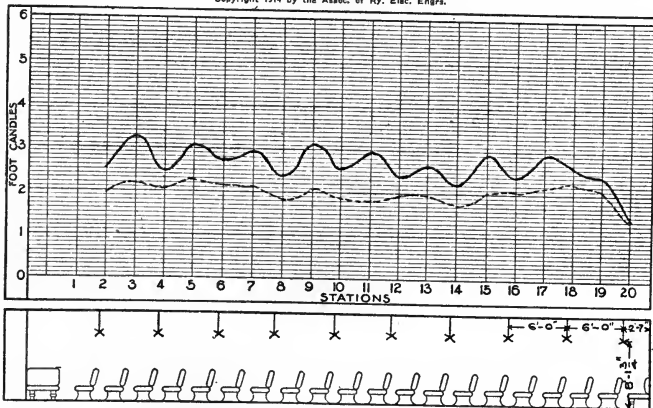

Fig. 4.—Illumination results in coach using electric center lamps, with open-mouth prismatic reflectors.

Fig. 5 shows the construction of the lamp used in the foregoing test.

Fig. 3 shows test with a similar type of fixture using the 50-watt train lighting electric lamps. The illumination is considerably

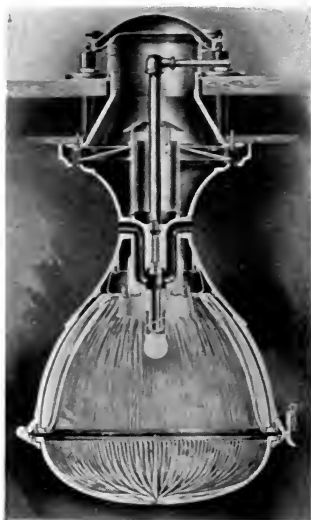

Fig. 5.—Lamp used in test, Fig. 2.



Fig. 6.—Lamp used in test, Fig. 4.



Fig. 7.—Lamp used in test, Fig. 8.

*(Facing page 500.)*



Fig. 8.—Interior of dining car.



Fig. 9.—Interior of dining car with indirect center lighting, and direct side lighting.

lower than in the preceding test and less uniform, there being more difference between the aisle and the window sittings.

Fig. 5 shows the result with center lighting, using prismatic open-mouth reflectors, and Fig. 6 shows the type of unit used in this test.

TEST No. 3 1/2  
**DATA ON ILLUMINATION EFFICIENCY AND UNIFORMITY**

ILLUMINATION 33 IN. ABOVE FLOOR OF CAR

	AVERAGE FOOT CANDLES			
	Window Seats	Aisle Seats	Mens on Seats	Entire Car
45° reading plane	1.82	2.25	2.04	
Horizontal plane			2.69	3.55
Per cent. of total light delivered on horizontal plane.....	40.3%			
Mean variation from average, 45° reading plane.....	12.8%			
Lowest four values (excluding station 20), 45° reading plane. ....	1.62 f.c. 1.60 f.c. 2.02 f.c. 2.06 f.c.			

**ELECTRIC LIGHTING**

CENTER DICE 2 SEAT SPACING  
 Type of Car 70 ft. Coach

Description of Unit Medium Density Opal-Machbeth-Evans  
 No. 1624

50 watt 6-30 Tungsten Lamps  
 Base Contact of Electric Lamp 5/8"

above top of REFLECTOR

Screening Angle of Reflector 29°

Coefficient of Reflector of car headlighting = 26.3%

**LIGHT OUTPUT OF ONE UNIT**

Total light, lamp alone:—.....400 lumens  
 Lamp with reflector:—  
 Distribution.....100° to 180° = 78.1 lumens  
 50° to 100° = 112.6 lumens  
 0° to 50° = 157.6 lumens  
 Total = 348.3 lumens

Generated lumens per running foot of car = 66 2/3 lumens

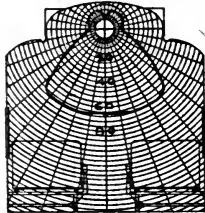

C. P.		C. P.		C. P.	
0°	68.6	65°	25.5	125°	15.7
5°	68.9	75°	18.8	135°	15.9
15°	70.4	85°	13.0	145°	15.6
25°	71.1	90°	12.2	155°	15.2
35°	71.8	95°	12.6	165°	14.5
45°	68.6	105°	14.0	175°	11.3
55°	43.9	115°	15.0	180°	10.4

**ILLUMINATION CURVE 45° READING PLANE**

Aisle seat illumination shown by full line

Window seat illumination shown by dotted line

For Car Plan and Test Station Locations see plan No. 1  
 Copyright 1914 by the Assoc. of Ry. Elec. Engrs.

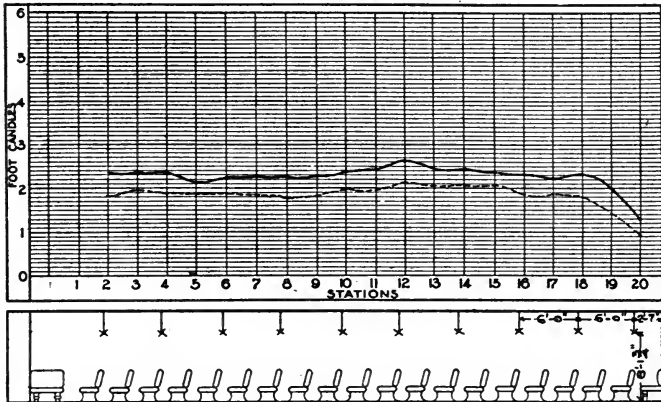

Fig. 10.—Illumination results in coach using electric center lamps with medium density opal open-mouth reflectors.

Fig. 10 shows the results obtained with medium density opal reflectors.

Fig. 11 shows the results obtained with heavy density opal reflectors.



Fig. 7 shows the type of unit used in the preceding test.

Fig. 12 is interesting as it shows side lighting with clear prismatic reflectors. The wattage is the same, as with the center lamps, and the results compare very closely.

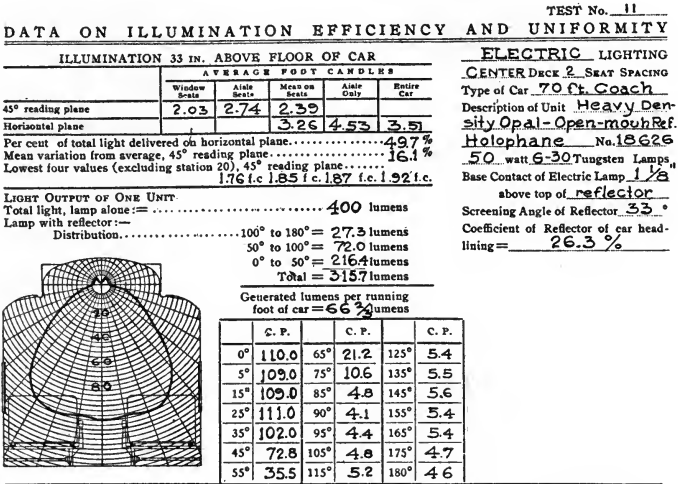

ILLUMINATION CURVE 45° READING PLANE  
 Aisle seat illumination shown by full line Window seat illumination shown by dotted line  
 For Car Plan and Test Station Locations see plan No. 1  
 Copyright 1914 by the Assoc. of Ry. Elec. Engrs.

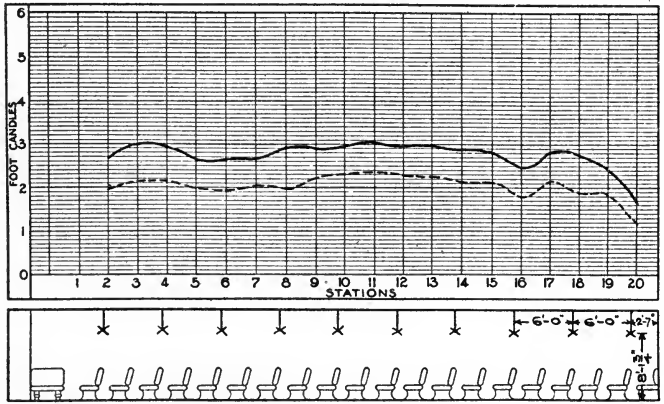

Fig. 11.—Illumination results in coach using electric center lamps with heavy density opal open-mouth reflectors.

Fig. 13 shows results with side lighting with medium density opal reflectors, and this test compares very closely with center lamp test, using the same class of reflector.

These tests show that by using units best adapted for car-lighting

service, illumination of about 2.5 foot-candles can be obtained on the reading plane by spacing the center units 6 feet apart and using lamps with an output of approximately 390 lumens per lamp. The same results can be obtained in side lighting by placing the units

TEST No. 42  
**DATA ON ILLUMINATION EFFICIENCY AND UNIFORMITY**

ILLUMINATION 33 IN. ABOVE FLOOR OF CAR

	AVERAGE FOOT CANDLES				
	Window Seats	Aisle Seats	Seats on Seats	Aisle Only	Entire Car
45° reading plane	1.16	1.51	1.34		
Horizontal plane			1.85	2.46	1.98

Per cent. of total light delivered on horizontal plane.....46.5%  
 Mean variation from average, 45° reading plane.....14.9%  
 Lowest four values (excluding station 20), 45° reading plane.....  
 1.02 f.c. 1.02 f.c. 1.04 f.c. 1.02 f.c.

**ELECTRIC LIGHTING**  
 Type of Car HALF DECK 2 SEAT SPACING  
 Description of Unit Prismatic Clear Reflector  
Holophane No. 18221  
15 watt 6.1/2 Tungsten Lamps  
 Base Contact of Electric Lamp 1/2  
 above top of REFLECTOR  
 Screening Angle of Reflector 36°  
 Coefficient of Reflector of car headlining = 26.3%

**LIGHT OUTPUT OF ONE UNIT**  
 Total light, lamp alone: = ..... 120 lumens  
 Lamp with reflector:—  
 Distribution..... 100° to 180° = 13.2 lumens  
 50° to 100° = 20.4 lumens  
 0° to 50° = 64.7 lumens  
 Total = 98.3 lumens

Generated lumens per running foot of car = 40 lumens

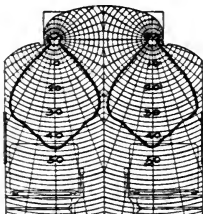

	C P		C P		C P
0°	43.7	65°	4.7	125°	3.4
5°	45.2	75°	4.2	135°	1.5
15°	39.0	85°	3.4	145°	1.0
25°	37.8	90°	3.4	155°	
35°	35.0	95°	3.6	165°	
45°	13.1	105°	4.0	175°	
55°	4.1	115°	4.2	180°	

ILLUMINATION CURVE 45° READING PLANE  
 Aisle seat illumination shown by full line Window seat illumination shown by dotted line  
 For Car Plan and Test Station Locations see plan No. 2  
 Copyright 1914 by the Assoc. of Ry. Elec. Engrs.

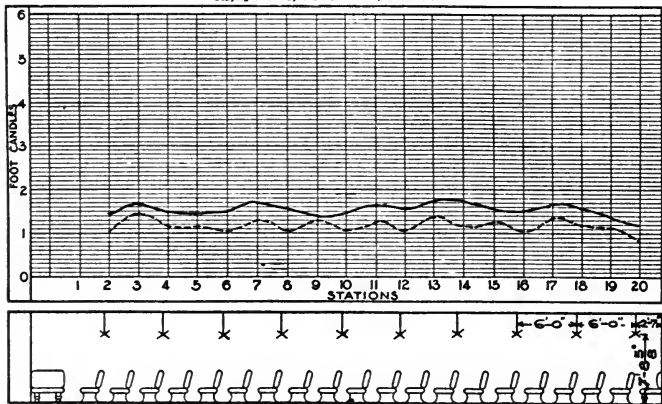

Fig. 12.—Illumination results in coach using electric side lamps with open-mouth prismatic reflectors.

6 feet apart, and using lamps with an output of 220 lumens per lamp. This allows a depreciation of 40 per cent. in the efficiency of the lighting system before the illumination drops to 1.5 foot-candles.

Direct lighting with a reflector of medium or heavy density is most

satisfactory for a coach, as it is much more efficient than either an indirect system or a direct system using a light density reflector since the walls and ceilings cannot be kept in proper condition to reflect any appreciable amount of the light which falls on them. The

TEST No. 49  
**DATA ON ILLUMINATION EFFICIENCY AND UNIFORMITY**

**ILLUMINATION 33 IN. ABOVE FLOOR OF CAR**

	AVERAGE FOOT CANDLES				
	Window Seats	Aisle Seats	Meas on Seats	Aisle Only	Center Car
45° reading plane	1.04	1.20			
Horizontal plane			1.45	1.79	1.51

Per cent. of total light delivered on horizontal plane..... 35.6%  
 Mean variation from average, 45° reading plane..... 10.0%  
 Lowest four values (excluding station 20), 45° reading plane. ....  
 .89 f.c. .97 f.c. 1.00 f.c. 1.00 f.c.

**ELECTRIC LIGHTING**  
 Type of Car 70 ft Coach  
 Description of Unit Medium Density Opal Reflector  
Safety Co. No. 9011  
15 watt 6-18 Tungsten Lamps  
 Base Contact of Electric Lamp 0"  
 above top of **REFLECTOR**  
 Screening Angle of Reflector 27°  
 Coefficient of Reflector of car headlining = 26.3%

**LIGHT OUTPUT OF ONE UNIT**  
 Total light, lamp alone := ..... 120 lumens  
 Lamp with reflector :=  
 Distribution..... 100° to 180° = 25.4 lumens  
 50° to 100° = 32.9 lumens  
 0° to 50° = 40.6 lumens  
 Total = 98.9 lumens  
 Generated lumens per running foot of car = 40 lumens

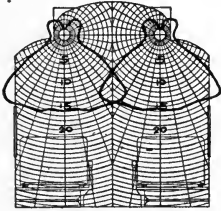

	C. P.	C. P.	C. P.
0°	16.6	6.6	5.0
5°	16.6	4.9	4.9
15°	17.2	4.0	4.8
25°	17.3	3.8	4.6
35°	18.0	4.0	4.3
45°	19.1	4.4	3.2
55°	13.8	4.8	2.4

**ILLUMINATION CURVE 45° READING PLANE**  
 Aisle seat illumination shown by full line  
 Window seat illumination shown by dotted line  
 For Car Plan and Test Station Locations see plan No. 2  
 Copyright 1914 by the Assoc. of Ry. Elec. Engrs.

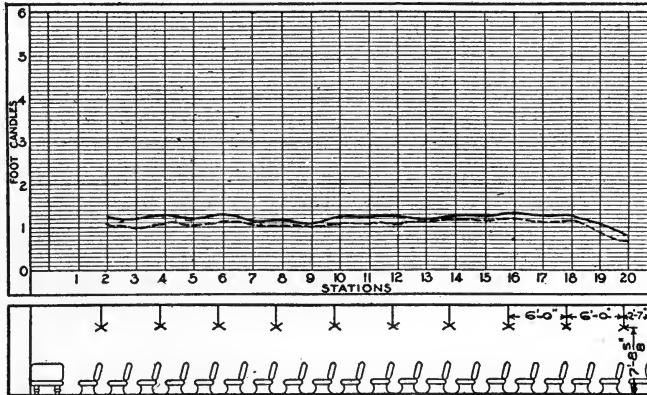

Fig. 13.—Illumination results in coach using electric side lamps with medium density opal open-mouth reflectors.

direct system with a reflector which properly screens the light source also affords, with the darker ceilings and walls, spaces of low illumination for the eye to rest.

*Dining Cars.*—Dining-car lighting is in a class apart from that of

other classes of cars, and it is in the dining car that most of the novelties in lighting are used. Obviously the table is the most important item in the car, and a high illumination must be concentrated on each table, although a fairly high general illumination has been found necessary so that the car will present a cheerful appearance to the person entering it. Installations with high intensity on the tables and low general illumination have not been found satisfactory. Good general illumination can be obtained from center fixtures mounted on the center deck, either direct or indirect lighting being used. For table illumination, fixtures should be mounted over each table, and no more satisfactory type of unit has been developed than that which uses a concentrating reflector and redirecting plate under it to give the proper distribution with maximum light on the table top.

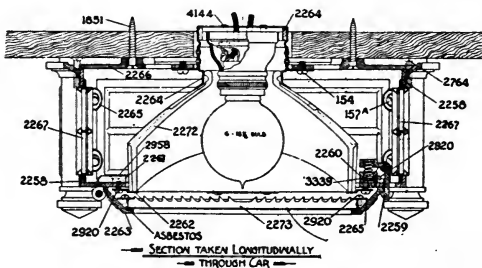

Fig. 14.—Dining-car lamp.

Fig. 8 shows a dining car equipped with this type of fixture.

Fig. 14 shows the construction of the table lamp and Figs. 9 and 15 types of indirect center lamps used. The most satisfactory dining-car illumination is obtained by lighting the tables with this type of fixture, and using a semi-indirect unit for the center lighting.

*Sleeping Cars.*—Sleeping cars require lighting for general illumination, for reading or working at the tables in the sections, and for illumination of the berths after they are made up.

General illumination is obtained by center lamps placed close to the ceiling to prevent interference of the fixture with the upper berth. Small units placed in the corner of each section provide additional local illumination for reading and to light the made-up berth.

Figs. 16 and 17 show sleepers equipped with such fixtures.

Fig. 19 shows the results of an illumination test made on the car shown in Fig. 17.

The staterooms of a sleeping car and of a compartment car are lighted in the same way.

Smoking rooms have a center lamp for general illumination and bracket lamps back of the fixed seats to afford proper lighting for reading.

The passageways are lighted by ceiling fixtures, using either an open-mouth reflector, or a fixture with reflector and directing plate set flush with the ceiling.

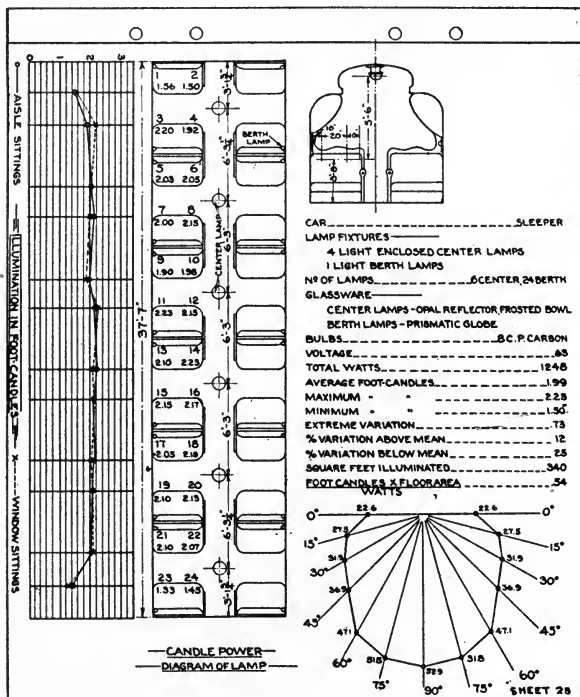

Fig. 19.—Illumination results in sleeping car, Fig. 17.

The proper lighting of the berth section of the car after all the berths are made up is best accomplished by a bracket lamp placed on the bulk-head facing the aisle; this allows all the center lamps to be extinguished, and affords sufficient light for passing through the car.

*Parlor Smoking Cars.*—This type of car presents a rather difficult problem, as the seats are arranged so that the occupant faces the center of the car. Best results are obtained by the use of a few center



Fig. 15.—Indirect lamps used for dining-car lighting.



Fig. 16.—Interior of sleeping car.

(Facing page 506.)



Fig. 17.—Interior of sleeping car.



Fig. 18.—Interior of parlor smoking car.



Fig. 20.—Interior of parlor car with side lighting.



Fig. 21.—Bag-rack portion of postal car.

(Facing page 506.)



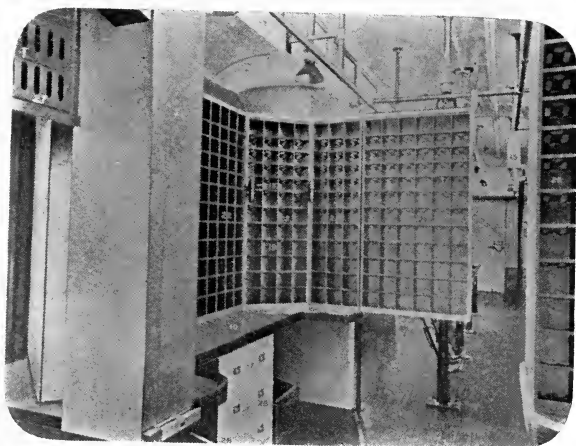

Fig. 22.—Letter-case portion of postal car.



Fig. 23.—Observation room of private car.

lamps for general illumination, and bracket lamps placed on the side of the car back of the chairs for reading light. Cars having a flat side deck can be fitted with reflecting units directly over the chairs instead of bracket lamps.

Such an installation is shown in Fig. 18.

*Parlor Cars.*—The conditions in this class of car are very similar to that in the passenger coach, and the same type of installation is used, although indirect lighting can be better used in parlor cars owing to the fact that the walls and ceilings can be maintained in better reflecting condition.

A parlor car equipped with side lighting is shown in Fig. 20.

*Postal Cars.*—Postal cars require greater illumination than those of any other class, as the work done demands constant and arduous use of the mail clerk's eyes. A very thorough investigation was conducted some years ago by one of the large railroads assisted by various manufacturers and participated in by the Standard Car Committee of the Post Office Department. Various types of installation were tested, and determinations were made of the amount of light necessary for the postal clerks to work. From the results obtained by these tests the committee issued specifications for lighting which must be met in every postal car.

Postal cars are generally divided into three sections: the letter distributing cases, the bag distributing racks, and the storage space. The distributing cases require high illumination on the vertical plane of the box labels, and on a horizontal plane for reading the addresses on the mail. The bag distributing racks require high illumination on the horizontal plane, for the labels on the bag racks. The storage end requires a fair general illumination.

The following are the specifications for illumination of postal cars issued by the Post Office Department:

These initial values are set to give proper illumination with a 40 per cent. depreciation in the efficiency of the installation.

Fig. 21 shows the bag-rack portion, and

Fig. 22 shows letter case of a postal car equipped to meet this specification.

*Private Cars.*—A private car is a combination of several types of cars and the lighting is accomplished in the different sections somewhat as it is in the class of car to which that section corresponds. The observation room resembles somewhat the parlor smoker, and in this part of the car general illumination is obtained by center lighting, with bracket lamps behind the chairs, or half deck units

## INITIAL VALUES OF ILLUMINATION REQUIRED

	Foot-candles	
	Minimum	Maximum
<i>Bag Rack Portion:</i>		
Center of Car—Horizontal.....	3.75	12.00
Mouth of Bags, measured 18 inches from side of car—		
Horizontal.....	2.00	12.00
<i>Letter Cases:</i>		
Over table—Horizontal.....	3.75	19.00
Face of Case—Vertical.....	1.66	19.00
Storage Portion.....	2.00	12.00

for local lighting. In private cars, however, more latitude is allowed in fixture design, and frequently the center lighting is obtained from one large fixture placed in the ceiling of the observation room.

Fig. 23 shows the observation room of a private car so equipped.

Local lighting is provided for the gauges and speed indicating devices with which most business and private cars are equipped, so that these instruments may be read when the other lamps in the car are not in use to allow track inspection from this part of the car at night.

The dining room of a private car is best lighted by a single unit placed directly over and throwing a high illumination on the table, with local lighting for the buffet.

The staterooms are lighted with center lamps, with local lighting for the mirrors. Where berths are used, berth lamps are provided, and at the beds special reading lamps are attached to the bed posts.

All cars having vestibules have lamps over each step, directing light on the steps. A flush type metal reflector is generally used.

*Street and Interurban Cars.*—The proper lighting of this type of car has, until recently, been neglected, both as to the amount of light furnished, and the proper application of the light sources. The carbon lamp was kept in use for a considerable time after the metallic filament lamp had displaced it in almost every other field. No means was used to direct the light to that portion of the car where it was to be used or to shield the filament from the eye. At the present time the metal filament lamp with proper reflectors are being used exclusively.

Two general arrangements of the units are in use. Cars having cross seats are lighted by a single row of units placed on the ceiling

along the center line of the car, the spacing varying from 4.5 to 10 ft. according to the size of lamp to be used. This spacing is also dependent on the length of the car, as the lamps are operated in series and must be in multiples of five.

When the seats are longitudinal, along the sides of the car, the units are arranged in two rows, about 22 in. from the side of the car. The same spacing is used as with the center lamps.

The lighting system is designed to give a minimum illumination on the plane of utilization of 1.5 foot-candles under conditions of 80 per cent. normal voltage, which means that at normal voltage the illumination will be about 3.75 foot-candles. This variation is a condition which will have to be corrected before street-car lighting can be called satisfactory. Up to the present time no device has been produced which satisfies the operating officials of this class of car as to cost and simplicity.

#### REFLECTORS AND GLASSWARE

A number of types of reflectors and enclosing units have been developed for car lighting uses.

For coach lighting, and other classes of cars where efficiency is the prime object, and appearance a secondary consideration, the open-mouth reflector is in almost universal use. Best results are obtained with a reflector giving the maximum candle-power at 45°.

The following are the principal types of this class of reflector, together with the illumination obtained and the efficiency using a 6-ft. spacing, giving  $66\frac{2}{3}$  generated lumens per running foot of the car:

	Average illumination on 45° reading planes, foot-candles			Illuminating efficiency on 45° plane
	Aisle seats	Window seats	Average	
Prismatic Clear.....	2.66	2.17	2.42	34.2
Heavy Density Opal.....	2.41	1.87	2.14	30.3
Medium Density Opal.....	2.00	1.65	1.83	25.9
Prismatic Satin Finish.....	1.94	1.50	1.72	24.3
Light Density Opal.....	1.79	1.52	1.66	23.5

Where appearance is the primary consideration enclosing units are used, and the energy efficiency somewhat sacrificed.

The following results are obtained with this class of unit under conditions similar to those stated above:

Enclosing units	Average illumination on 45° reading planes, foot-candles			Illumination efficiency on 45° plane
	Aisle seats	Window seats	Average	
Light Density Opal.....	1.09	0.97	1.03	14.6
Shallow Prismatic Reflector with Light Density Bowl.....	1.39	1.09	1.24	17.5
Reflecting and Diffusing Globes	1.44	1.24	1.34	19.0
Semi-indirect.....	1.56	1.24	1.40	19.8
Total Indirect.....	1.36	1.11	1.23	17.4
Bare Lamp.....	1.17	1.13	1.15	16.3

All of the foregoing are for electric light. For gas lighting the following results were obtained, the generated lumens being 130 per running foot of car:

Enclosing units	Average illumination on 45° reading planes, foot-candles			Illumination efficiency on 45° plane
	Aisle seats	Window seats	Average	
Deep Prismatic Reflector & Bowl.....	3.65	3.72	3.69	26.8
Reflecting & Diffusing Globes.	2.74	2.34	2.54	18.4
Medium Density Opal Globes.	2.08	1.52	1.80	13.1
C.R.I Diffusing Globes.....	1.92	1.67	1.80	13.1

Aluminized metal reflectors are in very general use in postal and baggage cars due to their high efficiency and durability.

### FIXTURES

Lighting fixtures for use in railroad cars require special design and construction, and embody some features not found in fixtures built for other purposes.

1. They must be substantial to withstand the constant vibration to which they are subjected.
2. They must be easily removable for refinishing when the car goes through its regular shopping.
3. The arrangements for holding the glassware must be such that

it can be easily applied, or removed for cleaning, but at the same time must be securely held so that there is no danger of its jarring loose.

4. They must be of suitable color and design to harmonize with the interior treatment of the car.

5. The mechanical design must be simple and all working parts must be easily accessible.

The first condition is met by careful mechanical design, suggested by experience in this class of work, as fixtures built for other uses are wholly unfit for use in railway cars.

The second feature is generally covered by a type of construction in which a plate or spider is firmly fastened to the car ceiling, this plate forming the support for the socket. The ornamental part of the fixture is secured to this plate, but may be removed without disturbing the electric connections or the attachment to the ceiling.

The arrangements for holding the glassware in enclosing units must be worked out for each type of glass employed. With a large proportion of the fixtures for electric lighting use is made of open mouth reflectors and for these, holders have been developed which fulfill the condition admirably. The ordinary type of holder equipped with set screws was quickly abandoned as being unsafe. One of the best holders developed consists of a spring clamp comprising a number of metal fingers which spring over and grip the neck of the reflector. In order to make the action of this spring clamp positive, a cap nut is screwed down against the spring clamp, locking the fingers against the neck of the reflector in such a manner that the spring of the clamp takes care of expansion in the glass and cushions it against vibration.

The question of suitable design is one which is governed to a certain extent by the wishes of the purchaser, but I believe that the results obtained in car lighting work compare very favorably with that in other lines.

Electric lamps are built so that the bulbs may be easily renewed, and the sockets and wiring easily accessible. Gas lamps are made so that they can be lighted without opening the bowl, mantles applied without the mantle being removed from the container until it is properly attached to the lamp, and no adjustments to the air or gas supply are necessary; in fact the lamps are made without any means of adjustment.

Much remains to be done before the lighting of railway cars will be all that can be desired, but I know of no other field where more effort is being expended to obtain proper and adequate illumination.



## THE LIGHTING OF YARDS, DOCKS AND OTHER OUTSIDE WORKS

BY J. L. MINICK

It is a notable fact that illuminating engineers generally have given only casual attention to the field of lighting in railway service and it is largely with the hope of stimulating interest in this field that this lecture has been prepared. Probably no other single industry offers such a wide variety of interesting problems for solution in which practically every known form of illuminant may be used to advantage. This field is open to the illuminating engineer if he will avail himself of the opportunities offered. Many railroads of importance have large engineering organizations but only a few employ men sufficiently well trained in this important branch of science to solve properly the many problems that constantly arise. Many of these problems are common to other industries which have come within the range of the illuminating engineer and their solutions are therefore well known. Many others are peculiar alone to railway service and it is from among these that the material for this lecture has been selected.

American railroads derive approximately three-quarters of their gross income from the handling of freight and about one-fifth from passenger service. All problems whose solution will in any way, improve, facilitate or stimulate the movement or handling of either freight or passengers, are of prime importance to the railroads in their endeavor to furnish adequate service to the public. The lighting of yards, docks and other outside works has been selected for review in this lecture as these problems are intimately connected with the handling of transportation and their importance is not generally well appreciated.

In presenting these problems it must be understood that the solutions suggested are not to be considered as final or conclusive. They represent the labors and investigations of only a limited number of engineers during the past five or six years. Improvements in illuminants and in the control of light are constantly removing many of the difficulties commonly encountered and the investigations of



railway committees and individuals are resulting in many changes in methods of operation which tend to simplify the lighting problems. Few tests have been conducted to show what intensities of illumination are required for different classes of service and it is for this reason that data of this character are not presented. The material presented deals largely with the practical aspect and gives some conception of the difficulties encountered in railway service.

### FREIGHT YARDS

*Description.*—The economical operation of important railroads requires that the roadway shall be divided into sections or divisions, each of sufficient length to give the train crews a full day's run under normal operating conditions. Shops, roundhouses and other facili-

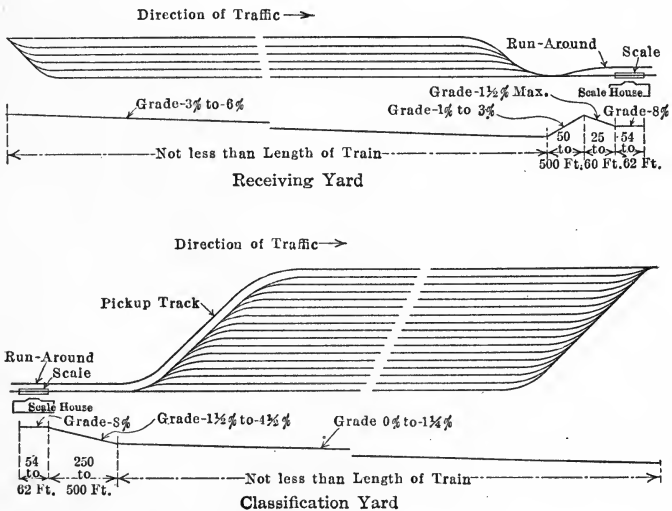

Fig. 1.—Diagrammatic sketch of freight yard.

ties are provided at division points for the inspection, maintenance and repair of the rolling equipment, also weigh scales and yards for weighing and classifying freight.

Freight originates in small package quantities, at stations provided for that purpose, and is here weighed and loaded for shipment, usually in box cars. Full car loads are received from warehouses, factories, mines, etc., which have siding connections with the main line. All of this miscellaneous freight, both small package and full cars, is collected by "way collection trains" and transported to the end of the division for weighing and classification.

Two general types of freight yards are in common use to-day; one in which the tracks are approximately level, requiring the constant use of locomotives for moving the cars, the other in which the tracks are arranged and graded to permit the movement of the cars by the force of gravity. This latter type is known as a "gravity" or "hump" yard, and since it is rapidly superseding the first-mentioned type, this type of yard has been selected for discussion.

*Pull-in Yard.*—When a freight train arrives at the end of a division it is delivered to the "pull-in" yard where the road crew turns it over to the yard crew. The pull-in yard consists of several tracks or sidings each long enough to receive a full train, which, in the case of full car loads, consists of from forty to sixty loaded cars or possibly as many as one hundred and fifty empty cars. Convenient track connections permit of easy access to the roundhouse and storage track for the locomotives and cabin cars. The yard crew moves the train into the "receiving" yard, as soon as possible to make room for the arrival of other trains.

*Receiving Yard.*—The receiving yard contains usually two or three times as many tracks as the pull-in yard and is of about equal length though the character of the freight handled, local conditions, etc., play very important parts in the arrangement and length of tracks in both of these yards. The tracks in the receiving yard are graded slightly in the direction of traffic to reduce to a minimum the steam power required for their movement.

The work in both of these yards is of such a nature as to require the train crews to be on their trains the larger part of the time. No work of any account is performed on the ground. The lighting requirements are not severe and usually whatever suffices for the neck of the classification yard or ladder tracks can be used in these yards to advantage.

*Weigh Scales.*—The success of rapid and accurate weighing is dependent upon the constant movement of cars across the scales at uniform speed. Weighing is usually continued throughout the entire twenty-four hours, and hence the artificial illumination provided must be such as to enable the weigh-master and yard crews to perform their duties equally well during all hours of the day and night.

In the lower end of the receiving yard an abrupt change from negative to positive grade takes place, the rise in track continuing until the rails are somewhat higher than the scale platform. From this point, commonly known as the "hump," they drop rapidly to the end of the scale platform. The scale platform also has a slight

negative grade. In operation a locomotive is attached to the rear end of the train in the receiving yard to regulate its speed. The grade is such that the weight of the train moving down the grade toward the scales is sufficient to force the first two or three cars up the grade over the hump, thus requiring the locomotive to regulate the speed only by applying additional power as the train is decreased in length.

As the cars pass over the hump a point is reached where the reverse in grade causes the last car to pull away from the train. At this point the car is cut loose and allowed to "float" across the scale platform. The grades and distances are so arranged and proportioned that all cars, regardless of size or weight, move across the scales at approximately the same velocity. Usually there is an interval of about one-half car length between cars. At the point of cutting the cars the grades are such that the cars move a distance of not to exceed 6 ft. during which the couplers may be opened. During the interval of cutting a visual inspection is made of the running gear, brake rigging, etc.

These operations require illumination of fairly high intensities localized within a comparatively small ground area. The couplers must be sufficiently well illuminated to enable the car cutter to note quickly when they begin to part. All parts underneath the car must be well illuminated to enable the detection of loose, bent or broken parts. Usually a single large lamp will serve for this purpose. Experience shows that it should be placed thirty or more feet above the rail and at least 10 ft. from the center of the track to give proper clearance between the pole and the sides of passing cars. The pole should be set opposite the point where the cars are cut. The distance from here to the end of the scale platform will vary with the type of hump used. With earth-fill humps it may be as great as 60 ft., while with the more modern mechanical humps, with which changes in elevation are secured at will by mechanical means, it will vary from 25 to 36 ft. In several instances two lamps have been used, one on each side of the track.

Several types of lamps have been tried in this service but none of them have proven as satisfactory as the incandescent lamp. The 500-watt vacuum type lamp has been generally used, though a lamp of slightly larger size would probably have been used had it been available at the time of making the initial installation. The recent introduction of the gas-filled lamp, with its increased candle-power for the same wattage, provides a satisfactory means for increasing

the illumination without great expense. The reflector should be of the distributing type and designed to give the maximum intensity at about 45 degrees. Its skirt should be extended to shield the lamp from the range of vision of the weigh-master and others employed in the vicinity of the scale house. All illumination underneath the car must come from reflection from the ground. In many instances clean river gravel, crushed oyster shells, white-wash and other light colored substances have been spread over the ground to increase the reflection. Arc lamps have proved unsatisfactory principally on account of the unsteadiness of the arc.

As previously stated the grades, dimensions, etc., of the hump are so proportioned as to give each car, as nearly as possible, the same momentum as it passes over the scale platform. The average rate of movement is from ten to fifteen seconds for each car, from the instant the front wheels mount the platform until the rear wheels leave. There is an interval of about one-half car length between cars which gives an interval of from twenty to twenty-five seconds in which all of the operations incidental to weighing must be performed. During this interval the weigh-master must read the initials, number and light weight of the car and verify the records on the manifest in his possession and in addition he must weigh the car and make record on the manifest of the total, light and net weights.

The weight must be taken after the rear wheels have mounted and before the front wheels leave the platform. The car is free to move from 10 to 15 ft. on the scale platform under this condition. This represents an interval of time of from one and one-quarter to two seconds during which the weight may be taken. Under these conditions all cars are weighed to within less than 200 pounds though many of them exceed 175,000 pounds in total weight. The average rate of weighing is slightly less than three cars per minute while under favorable conditions it may run as high as four per minute. This rate of movement makes it necessary for each operation to be conducted with certainty as a single failure will interrupt the operation of the entire yard until the car involved can be returned to the receiving yard for reweighing.

The illumination at night must be the equivalent of that under daylight conditions. There are three opportunities for the weigh-master to read the initials of the car, etc.; on the front end of the car as it approaches the scales, on the side of the car as it passes over the scales, and again on the rear end of the car as it leaves the scales.

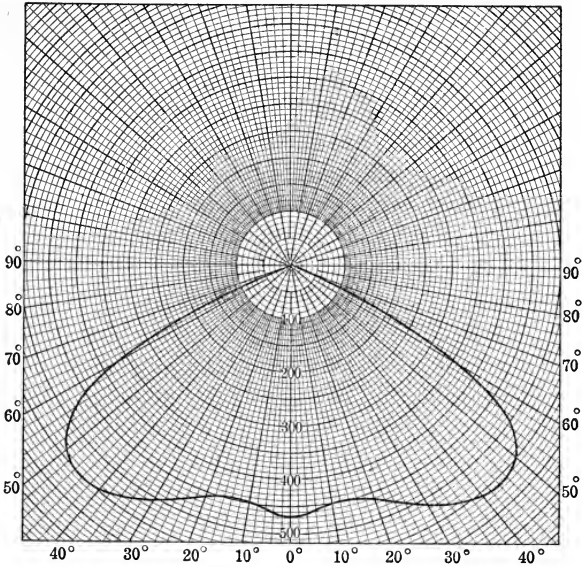

Fig. 2.—Candle-power curve of scale-lighting unit with special reflector; 200-watt lamp; horizontal plane.

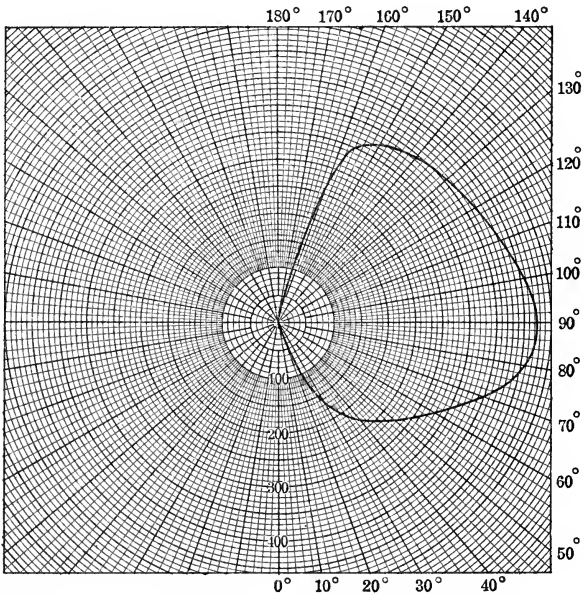

Fig. 3.—Candle-power curve of scale-lighting unit with special reflector; 200-watt lamp; vertical plane.

A special reflector has been designed by one of the eastern railroads for this service, as it was not possible, at the time the original installation was made, to purchase on the open market a reflector giving the desired distribution. This reflector is of the angle type with the lamp pendant and the axis of the reflector in the horizontal plane or at right angles to the axis of the lamp. It is approximately 13 in. in diameter by  $5\frac{1}{2}$  in. deep and was designed to accommodate a 250-watt vacuum-type lamp. The 200-watt gas-filled lamp has lately been substituted with satisfactory results and with the latter lamp the reflector gives maximum candle-power at about 45 degrees in the horizontal and at 90 degrees in the vertical plane. The design is such, however, that the larger part of the light flux in the vertical plane lays above the horizontal or between the angles of say, 70 and 140 degrees. A few of the recently developed types of porcelain enameled reflectors give very close to this distribution and may now be purchased on the open market.

Six of these fixtures are mounted along the front of the scale house facing the track at a height of 7.5 ft. from the rail to the bottom of the socket. The spacing varies slightly with local conditions and the type of scales used. The fixture nearest the hump is adjusted to illuminate the front end of the car as it approaches the scales, particularly the number panel which invariably appears in the upper right-hand corner of the end of the car, the observer facing the car. This lettering covers an area approximately 16 in. high by 30 in. long, with the bottom from 9 to 10 ft. above the rail. The next four fixtures are adjusted to illuminate the lettering on the side of the car, which covers an area about 40 in. high by 10 or 12 ft. long, though in many instances the initials extend the entire length of the car. The bottom of this lettering is about 4 ft. above the rails. The last fixture illuminates the rear end of the car as it passes off the scales.

Oil-fuel head-lamps, mounted along the front of the scale house, were originally used in this service. They were very unsatisfactory, as the chimneys quickly became smoked and, even under the most favorable conditions, the intensity on the side of the car was low. Flame arc lamps were next used and, although the intensity of the illumination was greatly increased, these also were unsatisfactory principally on account of the unsteadiness of the arc and the welding of the electrodes.

Since the body of the car overhangs the trucks at each end by several feet, the trailing wheels are not illuminated and it is difficult

for the weigh-master to determine quickly when the car has left the platform. A spot-lamp is placed on the side of the scale house, several feet above the rail and near the end of the platform, with the beam trained upon the ends of the rails. The reflector used is of the concentrating type to insure high intensity of illumination.

The scale beam is mounted within a bay window opposite the center of the scale platform with a clearance of about 3 ft. between the car and the edge of the window. It is illuminated by means of three pendant fixtures, one opposite the center and one opposite each end of the beam. These are mounted 7 ft. from the floor to the bottom of the reflector and in a line 12 in. back from and parallel to the scale beam. Special reflectors and 25-watt lamps are used to illuminate only the scale beam and counterpoise. These reflectors are special in that they have unusually long skirts to prevent direct light striking the glass of the window and being reflected in such manner as to obscure the weigh-master's vision. Great care must be exercised to see that none of the polished metal parts give objectionable reflection.

As each car moves off the scales and down the grade into the classification yard a car rider mounts it and regulates its speed by the hand brakes so that it will strike the cars standing in the yard with only sufficient force to close and lock the coupler. A second large lamp mounted on a pole, usually a duplicate of the equipment at the hump, furnishes sufficient illumination for the rider to mount the car safely.

All of the lamps in the immediate vicinity of the scales are operated from multiple circuits with control switches inside the scale house within easy reach of the weigh-master. This enables him to make use of artificial illumination during the hours of dusk and dawn and during dark periods of the day when the natural illumination is ample for all other yard operations. All reflectors outside the scale house, particularly those in the immediate vicinity of the scales, must have skirts not only to shield the lamps from the range of vision of the weigh-master but to prevent reflection on the glass of the windows, since much of the weighing must be done while the windows are closed.

The scale mechanism requires frequent inspection, particularly the knife edges, knuckles, etc. Artificial lighting is necessary for this purpose as all of the mechanism lies within the vault underneath the platform. Many structural shapes are used and their reinforcements and connections offer so many obstructions to general

illumination that this service is necessarily restricted to the spot lighting of important parts, supplemented by a limited number of bare lamps for general illumination. Spot lighting is secured by the use of porcelain enamel metal angle reflectors of the concentrating type fitted with 25-watt or 40-watt lamps. Portable lamps with extension cord connections are required for the examination of the parts lying within the regions of shadow.

*Classification Yard.*—As the car leaves the scales it passes down an incline of fairly heavy grade, of from 250 to 500 ft. in length, leading to the “ladder track” connecting with the yard tracks.

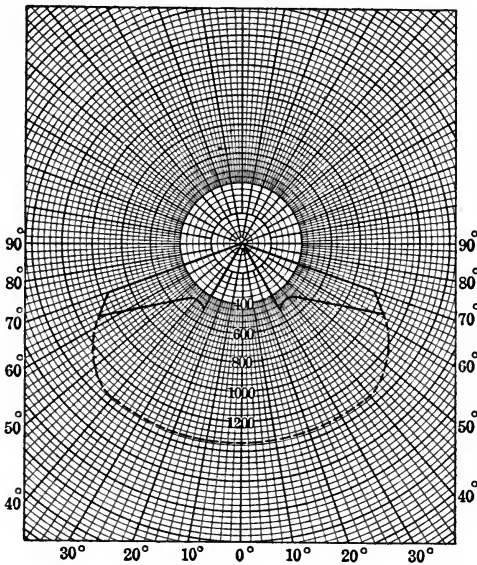

Fig. 4.—Candle-power curve ladder-track unit, maximum and minimum.

The yard may vary in width from eight or ten to as many as twenty-five or more tracks so that the ladder track will contain a large number of switches set closely together. These switches are operated electrically or electro-pneumatically from a tower provided for that purpose. Since it is necessary that the car riders see all of the switches clearly, and as they ride on the rear ends of the cars, excellent illumination of the switches must be provided.

At the opposite end of the classification yard there is a ladder track which connects with the pull-out yard. The type of lighting units serving the ladder track may usually be utilized in the pull-in, re-



ceiving and pull-out yards to advantage. Two principal conditions must be satisfied. With a mounting height of 35 ft. the candle-power values in the 30-45-deg. zone must be relatively high to illuminate properly the ladder track switches, and again in the 60-70-deg. zone high values are required for the illumination of the tops of the cars, particularly in the receiving yard which may be six or eight tracks wide. At 30 degrees the candle-power value should be not less than about 600 nor more than 1300. At from 60 to 65 degrees it is fixed very closely at 1000. Fig. 4 shows the maximum and minimum values of candle-power for 35-ft. mounting height.

Traffic rules require that there shall be safe clearance between the poles and the sides of cars and the allowances are such that the poles

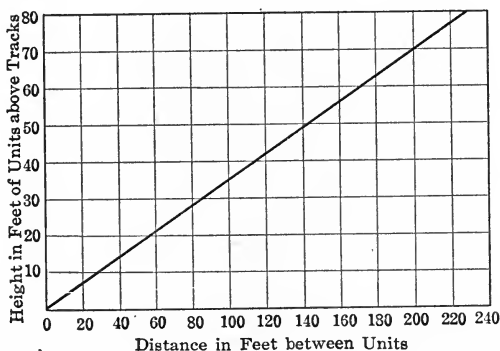

Fig. 5.—Mounting heights and spacings, ladder-track units, pull-in-receiving and pull-out yards.

must be set at least 10 ft. from the center of the track. Pole steps must be set parallel to the track rather than at right angles to it. On straight track, where switches and other local conditions permit, pole spacings should not exceed 100 ft., while on curved track and in the vicinity of switches, they should be much less for this type of fixture. Good practice requires that each switch shall have at least one lamp not further than 30 to 40 ft. from it. Fig. 5 gives maximum spacing for mounting heights up to 80 ft. Under normal conditions spacings should preferably be about 75 per cent. of the values given.

The common conception of the problem of classification yard lighting is that of providing a fairly even distribution of light over a large expanse of railway tracks. This, however, is an erroneous impression as the absence of cars means that no work is being per-

formed and light is then unnecessary. This problem has on several occasions, been likened to that of attempting to light a large city, of relatively tall buildings and narrow streets and alleys, entirely from the outskirts of the city. Owing to the large space required for clearance purposes between cars and poles or other obstructions, it is seldom possible to secure sufficient space for pole lines through the center of the yard. The relatively high cost and the difficulty of securing straight poles 40 ft. or more in length usually makes it necessary to confine the pole line construction to 35-ft. poles. When set in 5-ft. holes and fitted with appropriate pole tops for supporting

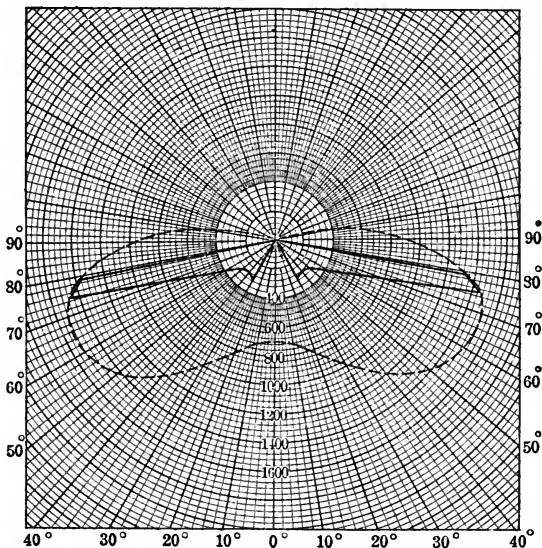

Fig. 6.—Candle-power curve, classification yard unit; maximum and minimum.

the lamps, this length of pole gives a clear height of the lamp above the rail of from 32 to 35 ft.

The tops of the cars must be well illuminated. The riding of moving cars is a more or less hazardous occupation and as the riders perform their principal duties on the tops of cars it is essential that they be given sufficient illumination to make their positions secure. The illumination must be sufficient to enable them to see clearly other cars on the same track and thus judge distances and so regulate the speed of the cars as to make the coupling without injury to the load or equipment. Finally the illumination between the cars must be

sufficient to permit each rider to climb off a car and cross the yard without danger of accident.

It is obvious that the units most satisfactory for lighting the body of the yard, under the conditions described, are those which have very flat candle-power distribution curves. With an effective mounting height of only about 20 ft. above the tops of the cars it

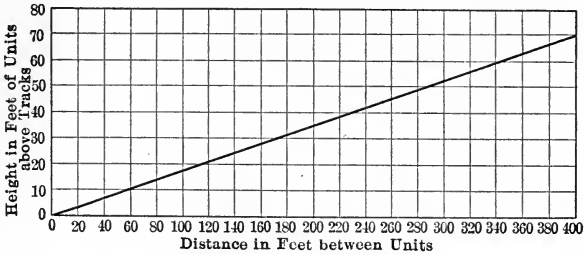

Fig. 7.—Mounting heights and spacings classification yard fixtures.

is necessary that candle-power values shall be very high immediately below the horizontal, or at say the angle of 80 to 85 degrees, if yards of great width are to be properly illuminated. Fig. 6 shows the maximum and minimum candle-power values required for a mounting height of 35 ft.

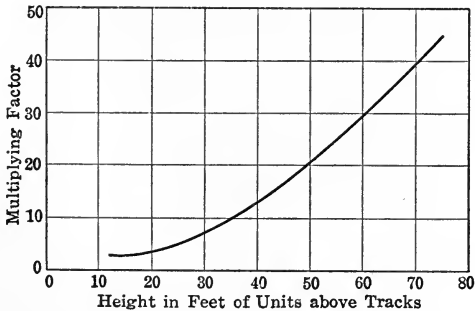

Fig. 8.—Multiplying factors yard lighting fixtures.

While it is desirable to mount the lamps as high as possible, local conditions will largely govern this feature. As previously stated, poles more than 35 ft. in length are usually difficult to secure. On the other hand, the possibility of having to shift the pole line to a new location at some future time, by reason of changes in track arrangement, etc., makes it particularly desirable that short, stout poles be used. Lamp spacings will vary with the mounting heights

and should not exceed 200 ft. for 35 ft. in height. It is good practice to stagger the poles along one side of the yard with reference to those on the opposite side. Fig. 7 shows the maximum spacings for mounting heights of 70 ft. and less. It is common practice to limit the spacings used to approximately three-quarters of these values.

The size of the lamp will vary with the spacing and mounting height. The candle-power curves shown in Fig. 4 and Fig. 6 are based upon a mounting height of 35 ft. If for any reason it is found necessary or desirable to use a different mounting height, in any of the yards to which reference is made, the size of the lamp must be increased or decreased sufficiently to give candle-power values which may be determined by multiplying the values shown in Fig. 4 and Fig. 6 by the factors shown in Fig. 8 for the several mounting heights.

*Pull-out Yard.*—The pull-out yard lies immediately beyond the classification yard. Here full trains are made up from cars removed from the classification yard and prepared for movement over the main line. Like the pull-in yard, this yard consists of only a limited number of tracks, each long enough to accommodate a full train. Very little of the work requires men to pass between or climb over cars, consequently the lighting requirements are not severe. The type of lamp used in the pull-in and receiving yards and along the ladder track is satisfactory for this service and the same mounting heights and pole spacings will apply.

*Service and Types of Illuminants.*—Since the lamps must be placed overhead, poles for supporting them are necessary. Changes and improvements in operating conditions and methods frequently require that the tracks, and consequently the lamps, be changed in location. This precludes the possibility of employing anything approaching permanent construction, such as underground conduit systems, steel poles or towers, catenary construction for suspending a large number of small lamps over the body of the yard, etc. The enormous length of transmission line required, because of the necessity for locating the poles along the outer edge of the yard and on other unoccupied ground areas, prohibits the use of multiple circuits. Several of the larger yards in use to-day are from 4 to 6 miles in length and require from 10 to 15 miles of pole line construction. Series circuits are therefore commonly used.

Practically all forms of arc lamps have been used in this service with varying degrees of success. Arc lamps are not entirely satisfactory. They require frequent trimming and trimming in an active

freight yard is a more or less dangerous occupation. Runways for repair and supply trucks cannot be provided, and hence the trimmer must make his rounds on foot and all supplies and all lamps removed for repairs must be transported by hand. These items must be given serious consideration and that system of lighting should be selected which reduces to a minimum the difficulties of operation and maintenance, even though the illumination of the yard be interfered with to a slight extent.

The old open arc lamp was probably the first type of electric lamp used in this service. It was undoubtedly a big improvement over the trainman's hand lantern then in common use. This lamp soon gave way to the direct-current enclosed arc which in turn was superseded by the alternating-current enclosed arc lamp. All of these lamps were expensive in operation as compared with later types. They were inefficient and did not give proper light distribution for the service required.

The luminous or magnetite arc lamp approaches most closely to the ideal from the standpoint of light distribution. It gives its maximum candle-power at from 80 to 85 degrees, thus making it possible to light the center of the yard fairly well even though it be as much as 400 ft. wide. The "flat distribution" also permits the use of comparatively short poles which is a big advantage from a construction standpoint. Flame arc lamps have not given satisfaction for two principal reasons: first, while the candle-power intensities at 15 degrees below the horizontal are sufficient to illuminate the center of the yard, the intensities at lower angles are great enough to give very bright spots in the immediate vicinity of the lamp poles, which is objectionable to the car riders; and second, the excessive flicker of the arc and the frequent welding of electrodes causes annoyance and inconvenience.

Large size incandescent lamps, fitted with refracting glassware, are the most attractive units at the present time. By their use the hazards of cleaning and trimming are reduced to a minimum. The shape of the refractor is such that a slight shifting of the lamp with reference to the refractor, will give almost any shape of candle-power distribution curve desired. Finally the energy consumption is nearly as low, for equal yard illumination, as for any of the series arc systems now employed. At the present time, however, the sizes of street series incandescent lamps regularly manufactured in ampere ranges up to 7.5 are probably not large enough to be competitive with the luminous arc lamps for wide

yards, unless pole space can be reserved through the yard for the incandescent lamps. If pole space can be reserved for this purpose, the distances shown in Fig. 5 may be used as the spacing between pole lines through the yard. The 600-c.p. gas-filled lamp with refractor unit is competitive, both in power consumption and candle-power distribution, with the 4.0-amp. luminous arc lamp. The latter lamp, however, should not be used with spacings of more than 200 ft. The 6.6 amp. luminous arc, which may be used with spacings of 300 ft. or more, is a much more powerful unit than any of the incandescent lamp units now regularly manufactured, unless it be the 1000 candle-power 20.0-amp. series lamp, which is not a desirable lamp on account of the necessity for using a "compensator."

Projector lamps have been used to a limited extent in this service. The lamp is mounted near the hump and the beam is directed against the rear end of each car as it passes into the classification yard. The principal objections to this method of lighting are: the extreme high cost of operation, the necessity for the yard crew to avoid facing the light source thus increasing the difficulties of performing their duties, and finally, the danger of accidentally playing the beam on passenger trains operating on the adjacent main line, thus obscuring signals and possibly interfering with the vision of the engineman and fireman. Mercury vapor lamps of high candle-powers and flood-lighting units have also been used to a limited extent. In each of these installations the use of steel poles or towers, 75 ft. or more in height, is necessary though the number of lighting units is materially reduced. The use of towers or similar structures require permanent locations which are not always to be had at reasonable expense.

*Transfer Station.*—Small package freight must be classified or sorted for destination exactly as are full cars, and for the same purpose. There is a difference in the method of operation, however. The character of the freight handled requires that each package shall be removed from the way collection car and placed in another car consigned to, or to some point near, the destination of that package, where another classification will be made. Since much of this freight is heavy, trucks, sometimes two-wheel hand operated and other times four-wheel hand or motor operated, are used in handling the individual packages. This necessitates the construction of heavy platforms between adjacent tracks at approximately the elevation of the car floor, for the operation of the trucks. Much of this freight

must be protected from the weather so that roofs over the platforms are required and frequently sheds are provided for storing freight which has been unloaded but which cannot be loaded until the next or a succeeding day.

Usually two or more tracks, sometimes as many as ten or fifteen, are assigned to transfer service. The platforms will vary in length to accommodate from two or three to as many as 20 to 25 cars. They must be about 15 ft. wide to permit the operation of two lines of trucks on each side of the platform if necessary. The roof is supported by posts, the more modern types of construction employing the "umbrella" type of roof, supported by a single row of steel columns along the center of the platform. The tracks are so arranged that the edges of the cars are close to the edges of the platform. Where two or more platforms are used two or more tracks are placed between the platforms.

A single row of incandescent lamps, with distributing type porcelain enamel reflectors, will furnish illumination sufficient for the operation of trucks on the platform. The reflectors should shield the filament of the lamp from the natural range of vision. With a mounting height of 10 ft. and a spacing of not greatly to exceed 20 ft., 100-watt lamps give satisfactory service.

The difficult part of this problem, however, comes within the car. Here the address and lading of each package must be read and compared with the manifest. No satisfactory method of illuminating the interior of the car has yet been developed. The fixtures used must necessarily be of the portable type and of inexpensive construction, as many of them are lost through being left in the cars. They must be supported from overhead as the trucks must have access to all parts of the car floor. At the present time portable hand lamps without reflectors are used. Plug connections for this service are usually supported by metal conduits from overhead or mounted under the edges of the platform.

*Docks and Terminal Yards.*—Export freight is delivered to sea-coast points. Package and perishable freight is delivered to large covered piers where it is stored until boats can be secured for loading. Car load freight which can safely be exposed to the weather, is delivered to a yard in which it is unloaded and stored on the ground to await water shipment. Upon arrival of the boat it is reloaded on cars and shifted to the pier or dock where it is transferred to the boat.

The lighting of the covered pier is a comparatively simple problem.

Light is required only for the purposes of trucking and piling or stacking and for the verification of the manifest. Usually several rows of incandescent lamps fitted with distributing type porcelain enamel reflectors are used in this service. The candle-power of the lamp will of course vary with the mounting height and spacing. The spacing, however, should be so arranged as to give good light distribution without shadows on the truck-ways and the lamps should be as large as possible consistent with these and other local conditions. An illumination intensity of from 0.75 to 1.25 foot-candles along the truck-ways is sufficient. "All night circuits" are desirable along the truck-ways for the use of the night watchman.

The lighting of the storage yard represents a much different problem. Here freight is unloaded by locomotive type cranes and stored on the ground until a boat arrives, when it is reloaded and moved to the pier for loading on board ship. The tracks are arranged in pairs, one on which the cars are placed to be unloaded and the other for the use of the crane. The crane has an extreme reach of from 30 to 40 ft. so that the pairs of tracks are spaced on about 60-ft. centers to permit the storage of materials between them. This space, which has a clear width of possible 48 to 50 ft., is sometimes filled completely to a height of from 20 to 25 ft. The crane may be turned 360 degrees if necessary and when lifting loads close to the crane the lifting arm stands nearly vertical, the extreme height being probably 50 ft.

The handling of freight must be carried on during night hours, and hence artificial illumination is necessary. The extreme range of operation of the lifting arm of the crane prevents the use of pole lines with lamps suspended from the poles. Some attempt has been made to furnish lighting service by the use of portable standards carrying one or more large lamps and connected by flexible cables and plugs to a system of underground cables installed between the unloading tracks. This arrangement has not been satisfactory or successful for several reasons. The cost of installation for the service performed is very high and usually not warranted. The lighting standards must be short enough to permit free range of movement of the crane above them which places the lamps too low to be of value in unloading gondola cars or in stacking on top of large piles. The cable connections offer obstruction to walking in the vicinity of the crane and they are frequently broken or cut by materials falling upon them. The standards must be light enough



for convenient handling and hence the weight is such that they may be overturned readily and the lamps broken.

An attempt has also been made to mount the lighting units on the crane structure itself and by means of angle reflectors to distribute the light in useful directions. While this arrangement has given most excellent results from the standpoint of illumination a number of operating difficulties have been encountered which have not been entirely overcome. The use of a flexible cable for supplying current to the crane from an underground distributing system is undesirable for reasons already mentioned. The use of a small steam-driven generator, mounted on the crane and supplied with steam from the crane boiler, will probably not give satisfaction as the crane boiler is designed for intermittent duty in which the peak demand for steam may be four or five times the normal rating of the boiler. A gasoline or oil engine-driven generator, mounted on a small truck attached to the crane, has been used in this service, and where lifting magnets are used for the handling of iron and steel products, this is probably the most satisfactory arrangement for securing electrical energy in sufficiently large quantities to meet the demand. The vibration of the crane is excessive, especially when releasing loads suspended in the air by the lifting magnet, and lamp breakage is excessive unless shock absorbers are used in mounting the fixtures. Several devices of this kind are being developed to relieve the situation.

In this service four fixtures are mounted on top of the cab, two along each side. An additional fixture is mounted to the rear and one in front over each door. The lifting arm carries two fixtures, one about one-third the distance up from the bottom, the other about one-third the distance down from the top. The seven fixtures around the cab are adjusted to illuminate the complete circle surrounding the crane to a radius of about 80 ft. This plan permits the preparation of a new load while the crane is engaged in stacking. The two fixtures mounted on the lifting arm are arranged to illuminate the load while suspended in the air, regardless of the position of the lifting arm, and also while it is being stacked. Five-hundred-watt gas-filled lamps with porcelain enamel angle reflectors of the distributing type are used and the light is directed away from the crane so as not to interfere with the vision of the crane operator.

Heavy materials are usually handled by gantry, or bridge type, cranes from pier to boat or boat to pier. All important work takes place in the immediate vicinity of the crane and the lighting require-

ments in general are similar to those of the locomotive crane. Fixtures are mounted on the crane structure and appropriate designs of reflectors are employed to turn the light in useful directions, always keeping in mind that the light must be directed away from the crane operator. The lamps used vary in consumption from about 100 to 500 watts and even 1000 watts, depending upon the character of the work to be performed, the locations of the fixtures, mounting heights, etc.

#### PASSENGER PLATFORMS

*Description.*—Stations are provided at frequent intervals along the main or running tracks for the accommodation of passengers and the handling of mail, baggage and express matter. The stations at the ends of divisions and at other important points where crews and locomotives are changed, are known as "Terminal Stations." All others are classed as "Way Stations." Terminal stations are usually large and serve many tracks and trains. Some idea of the density of traffic at a large terminal may be gained from the following approximate figures:

Station	Trains per day	No. tracks
Broad Street Station, Phila. ....	500	16
Pennsylvania Station, Pgh. ....	480	19
South Station, Boston. ....	700	28
Pennsylvania Station, New York. ....	525	21

Both foot and truck traffic is heavy and continuous, requiring the use of long, wide platforms between tracks for loading and unloading. Way station traffic is generally light and intermittent.

*Terminal Stations.*—The tracks at terminal stations are usually arranged in pairs with platforms between, so that one platform will serve two trains. These platforms are usually about 15 ft. wide, though the tendency of late has been to increase this dimension slightly. With two trains at the same platform, it may be necessary to accommodate as many as 1000 passengers and 20 four-wheel trucks. The trucks are loaded with baggage, mail and express matter, each piece of which bears an address or number tag. The baggage checks are made of either cream, red, blue or green-colored cardboard printed in black ink. Addresses on mail bags and express matter are usually written with indelible pencil on white or yellow

paper. These must be identified and compared with the way-bills which may have corresponding colors. Colored berth and seat checks in Pullman service must also be identified. In the older stations the platforms are protected from the weather by a single arched roof spanning all of the tracks and platforms. In the more modern stations the platforms have individual roofs each supported by a single row of columns along the center of the platform.

Fairly even, though not necessarily high, illumination is required for foot and truck traffic. Fairly high illumination is required for the verification of the way-bills. Finally, light is required on the tops of the cars to permit icing, watering, etc., and all lamps should be shielded to enable the enginemen to judge distances and stop his train at the proper point. Metal reflectors, having an angle of cut-off of not to exceed 75 degrees, are commonly used in train sheds. The mounting height should be not less than 22 ft. nor more than 25 ft. above the rail. The spacing, and consequently the size of the lamp will vary with local conditions, particularly the location of the roof-supporting members to which the fixture must be attached. The average illumination intensity should be from 1.0 to 1.25 foot-candles. Glass reflectors should be used where the platforms have individual roofs.

*Way Stations.*—Each way station is provided with one or more platforms for the loading and unloading of passengers, mail, etc. They are paved with wood, brick or concrete and are illuminated at night by small lamps mounted on poles along the edge of the platform farthest from the track in the case of a side platform, or along the center of the platform in case it is between the tracks. The poles are spaced at intervals of approximately one-half car length to enable the enginemen, by counting them, to judge distances and stop his train at the proper point. At points 200 ft. at each side of the center line of the station “approach signs” attached to lighting poles, display the name of the station. The bottom of this sign is approximately 8 ft. above the platform as this has been selected as the proper height for convenient reading, either from within the car or from the station platform.

Distributing type porcelain enamel metal reflectors, with 25-watt lamps are used in this service. At the more important stations 40-watt lamps are sometimes used. The lamps are mounted on metal poles about 9.5 ft. above the platform to clear loaded baggage and mail trucks. At this height the ordinary types of reflectors shield the lamp completely from the view of the enginemen. A

special reflector has been designed to expose a small portion of the incandescent filament so that the engineman may count the poles by the flashes of bright light as he passes, without looking in that direction. Where shelters are used transparent numerals are sometimes set in the longitudinal roof trusses opposite the lamps to indicate the stopping points for trains of various lengths. The average illumination of way station platforms need not exceed 1.0 foot-candle.

### CONCLUSIONS

It should not be inferred from the foregoing that only a limited number of sizes and types of lighting units can be used to advantage in railway service. The scope of railway lighting is so broad that there should be, and there probably is, a distinct field for each of the common illuminants of the present day. Few railroads have established definite standards for their lighting service. There are, however, a limited number of general conditions which are beginning to be accepted as good practice in railway service as follows:

1. Incandescent lamps should be used in preference to arc lamps if local conditions will permit.
2. The candle-power of units and spacing intervals should be as large as possible consistent with good illumination.
3. Glass reflectors should be used inside office buildings, stations, etc., aluminized metal reflectors in shops and semi-exposed places and porcelain enamel reflectors in outside service.
4. All reflectors should shield from view the incandescent filament under normal operating conditions. This means, generally, an angle of cut-off of from 60 to 75 degrees.
5. All fixtures and auxiliaries should be as strong and rugged as possible consistent with the cost of installation.

### Bibliography

- H. KIRSCHBERG and A. C. COTTON. "Railway Illuminating Engineering Track Scale and Yard Lighting." Pittsburgh Section I. E. S., February 13, 1914.
- "Report of Committee on Outside Construction and Yard Lighting." Proceedings A. R. E. E., 1914.
- L. C. DOANE. "Lighting Railroad Yards with Large Incandescent Lamps." Railway Electrical Engineer, December, 1914.
- "Lighting Classification Yard, New York Central R. R., Air Line Junction, Ohio." Railway Electrical Engineer, December, 1915.
- "Report of Committee on Illumination." Proceedings A. R. E. E., 1916.
- Unpublished reports of the Pennsylvania Railroad.



## SIGN LIGHTING

BY LEONARD G. SHEPARD

I have made no attempt to find a record of the first sign. It is well known that signs have been in common use for centuries and many of these were undoubtedly more or less illuminated.

The sign of this age, with which we have to do is the sign made possible by the modern electric lamps. It was probably about 1880 that signs of this type began to be used.

To appreciate the present-day development, it will be well to know something of the earlier electric signs and their construction.

In 1883 a temporary sign reading "Welcome" was made by placing the old style wooden base sockets on a wooden background. The wiring between sockets was done on the back of the sign. The letters were 2 ft. in height and were formed of 16 candle-power lamps, spaced about 6 in. apart.

In 1884, an electric sign reading "Boston Oyster House" was designed for more permanent use. To make the sockets weatherproof they were filled with putty and the wire being the old style known as underwriters wire was wrapped with tape. The sign body and frame were made entirely of wood and over all a glass case was built like an ordinary show case. The lamps of that time had large plaster-of-Paris bases which were protected in this sign by covering them with soft rubber bands which covered also the outer end of the sockets.

A double-faced sign made about this time reading "Dime Museum" is said to have been about 12 ft. long, 3 ft. high and 2 or 3 ft. thick with 18-in. letters made up of electric lamps. Its clumsy bulk made it look like a dog house hung up over the sidewalk.

It is interesting to note that the electric flag sign, patriotically displayed throughout this country in the last year was anticipated twenty-eight years ago at the convention in Chicago where a sign made up with miniature or candelabra lamps was flashed on during the singing of the "Star Spangled Banner."

One of the first flashing signs was made for the World's Fair in 1893. The letters were 4 ft. high and of skeleton construction

attached to a wire mesh backing. The mechanism which flashed on one letter at a time was a crude affair made entirely of wood with brass strips and bronze contact brushes. It was operated by a  $\frac{1}{4}$ -hp. motor. It is said that almost as much light came from the arcing of the flasher contacts as from the sign. The sign was considered so dangerous that a man was kept constantly in attendance.

Possibly the largest electric sign ever made was constructed in 1899 during the reception to Admiral Dewey on his return from Manila. Letters 50 ft. high reading "Welcome Dewey" were placed on the Brooklyn Bridge and could be read from Staten Island five miles away. There was no background, the lamps being arranged on streamers to form the letters. No sockets were used, the leading-in wires from the lamps which were made up without bases being so connected that five lamps were put in series, the total electromotive force used being 550 volt. The lamps, of which over 8000 were required were spaced 12 in. apart throughout. This sign represented a remarkable example of series wiring. It must be remembered that the failure of a single lamp would have made a dark section 5 ft. long in the outline of the letter.

#### MODERN SIGN TYPES

The illuminated sign of to-day is made in so many different varieties and is used in such varying surroundings that it will be necessary to classify and explain briefly the construction of the several types to give an adequate idea of the state to which the industry has developed.

Roof signs (see Figs. 1 and 2) may be taken as including all the large, more or less, skeleton types installed above the roof level. In these signs the steel supporting structure or framework is usually the most important item. To place the electrical display at a proper height and in the best location from an advertising standpoint often requires a considerable structure and frequently too, it is necessary to reinforce the building and to carry the anchorage members way below the roof. This is mentioned, because at night the framework is not seen and no idea of the investment involved can be obtained without a full appreciation of this item.

The electrical work required to connect the sign parts to the nearest service including the installation of the flasher and fuse blocks depends more upon the flashing effects than upon the size of the sign.

The sign proper or sign face is usually quite simple in construction

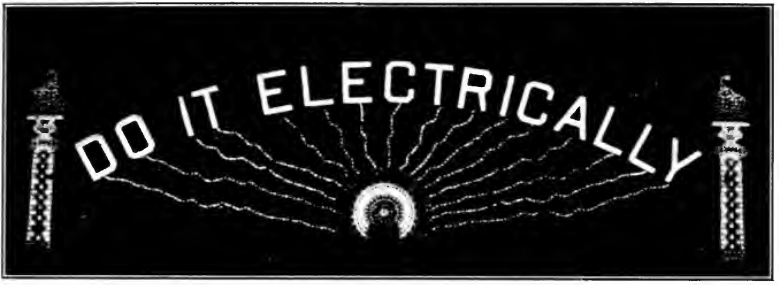

Fig. 1.—Roof sign.

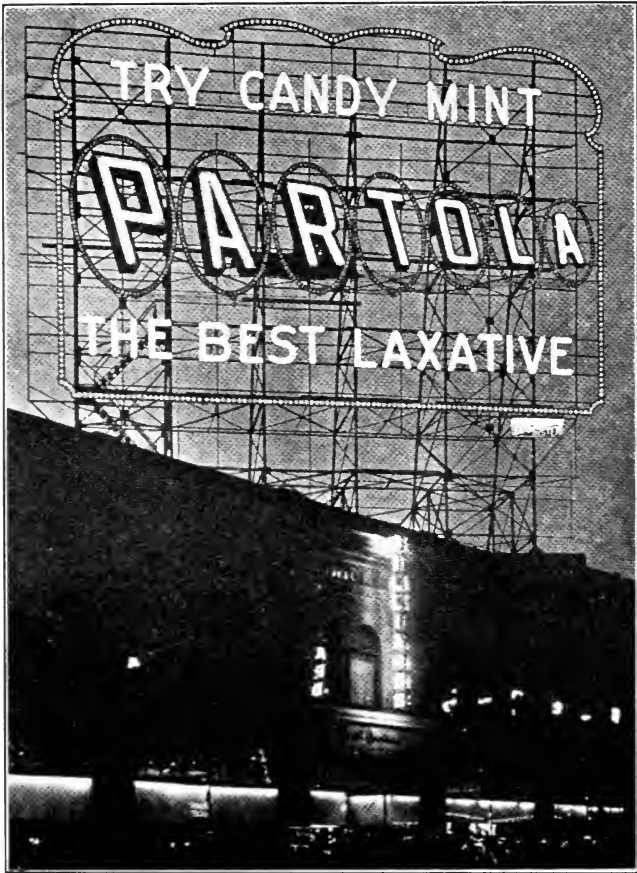

Fig. 2.—Roof sign.

(Facing page 336.)



attached to a wire mesh backing. The mechanism which flashed on one letter at a time was a crude affair made entirely of wood with brass strips and bronze contact brushes. It was operated by a  $\frac{1}{4}$ -hp. motor. It is said that almost as much light came from the arcing of the flasher contacts as from the sign. The sign was considered so dangerous that a man was kept constantly in attendance.

Possibly the largest electric sign ever made was constructed in 1899 during the reception to Admiral Dewey on his return from Manila. Letters 50 ft. high reading "Welcome Dewey" were placed on the Brooklyn Bridge and could be read from Staten Island five miles away. There was no background, the lamps being arranged on streamers to form the letters. No sockets were used, the leading-in wires from the lamps which were made up without bases being so connected that five lamps were put in series, the total electromotive force used being 550 volt. The lamps, of which over 8000 were required were spaced 12 in. apart throughout. This sign represented a remarkable example of series wiring. It must be remembered that the failure of a single lamp would have made a dark section 5 ft. long in the outline of the letter.

#### MODERN SIGN TYPES

The illuminated sign of to-day is made in so many different varieties and is used in such varying surroundings that it will be necessary to classify and explain briefly the construction of the several types to give an adequate idea of the state to which the industry has developed.

Roof signs (see Figs. 1 and 2) may be taken as including all the large, more or less, skeleton types installed above the roof level. In these signs the steel supporting structure or framework is usually the most important item. To place the electrical display at a proper height and in the best location from an advertising standpoint often requires a considerable structure and frequently too, it is necessary to reinforce the building and to carry the anchorage members way below the roof. This is mentioned, because at night the framework is not seen and no idea of the investment involved can be obtained without a full appreciation of this item.

The electrical work required to connect the sign parts to the nearest service including the installation of the flasher and fuse blocks depends more upon the flashing effects than upon the size of the sign.

The sign proper or sign face is usually quite simple in construction

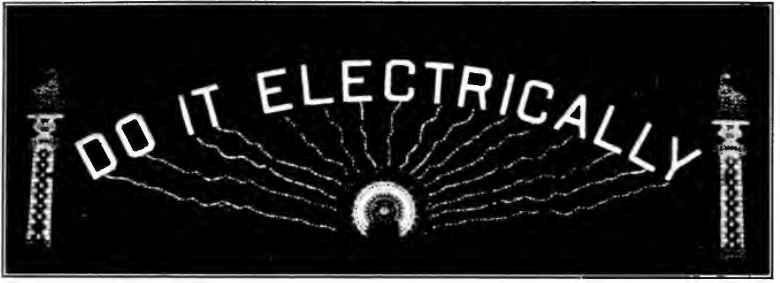

Fig. 1.—Roof sign.

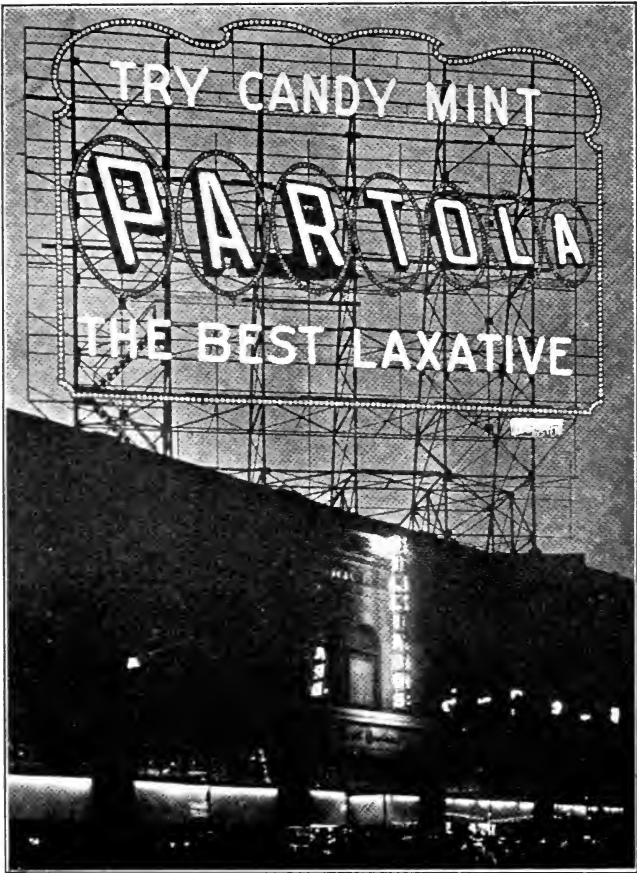

Fig. 2.—Roof sign.

(Facing page 336.)



Fig. 3.—Street sign.



Fig. 4.—Street sign.

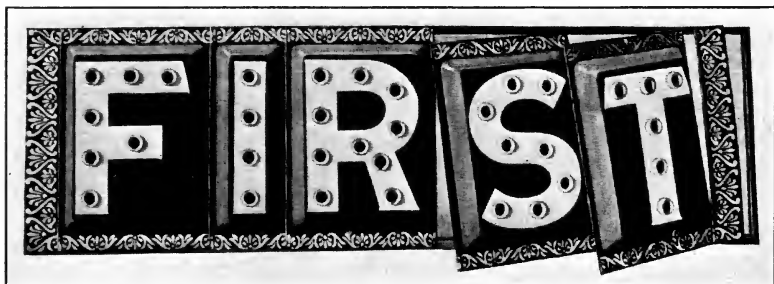

Fig. 5.—Porcelain enameled steel embossed letter sign.

consisting of light galvanized sheet steel cut out to form letters, figures or designs and backed up to give stiffness and to enclose the wiring. No internal frame is necessary as it is customary to place a lattice work of light channels on the face of the framework to support the display. The galvanized sheet steel serves as a support for the sockets and as a background for the painted designs.

The face of the letters and display parts is most commonly flat or flush as it is called. Sometimes where the parts are close together a flange from 1.5 in. to 4 in. high is carried around the edge of the face to give contrast and contribute to a clean-cut design. The flange is a bad collector of dust, and is not necessary where there is plenty of spacing.

Letters with a flange around the edge of the face or stroke are called trough letters. There is a special bevel trough letter made with a broad flange parallel to the face, on the outer edge of the bevel trough. This flange is painted black to improve the daylight effect as it makes a strong contrast against a light sky. An example of this construction may be seen in the 15-ft. letter roof sign on the Walkerville factory of the Ford Company.

Contrast between light and dark colors or between light and shadow is very necessary to a sharp clear sign. Frequently a flange or trough is used to emphasize an important line or to separate portions of a surface which flash or light up at different times.

While the painted surface of a new sign may be relied upon, at least in clear weather, to reflect enough light to bring out the features of a design under ordinary conditions, the lamp filaments must be depended upon to give the chief outline. The sockets therefore must be carefully located to obtain good results. The distance between sockets depends upon whether the sign is intended principally for distant reading or for a maximum effect at close range. In the first case large candle-power lamps can be spaced well apart but in the second the sockets must be close together to avoid a crude result. About 4 in. may be taken as a good standard spacing for close work.

While many excellent signs are equipped with low candle-power lamps the modern tendency, especially in the large cities, is toward greater brilliancies. Fifteen, twenty and twenty-five watt tungsten lamps are frequently used although the popular lamp is the ten-watt unit.

The beautiful color effects are obtained by the use of colored lamps either natural or dipped or with color caps or hoods of colored

glass fitted over the lamps. The dipped lamps probably allow the greatest variation in tint, but as it is practically impossible to obtain a lacquer that will adhere permanently to the bulb in all kinds of weather, the color caps or hoods are more satisfactory. A good illustration of the difference in the effect of the cap and the hood may be seen in the many flag signs installed during the last year or two (Fig. 6). In the popular 4 ft. flag the lamps in the union are placed in the white stars. A blue cap gives the proper blue effect for that portion of the flag while the direct rays from the filament behind the cap light up the white stars. On the red

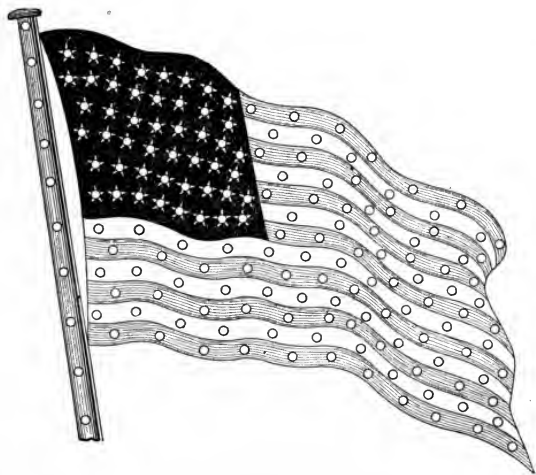

Fig. 3.—Electric flag sign.

and white stripes the hoods give a solid red or white effect as is desired.

Certainly any discussion of modern roof signs would be incomplete were the flashing effects omitted. On the other hand a book could easily be written in explanation of the many variations of this phase of the sign industry.

All flashing effects are produced by switching on certain lamps or groups of lamps in a certain sequence and with due regard to time periods. The mechanism, usually motor driven, which makes and breaks the many different electric circuits, some as fast as 200 or 300 times a minute, some with currents as large as 100 or 200 amperes, is a very important part of the installation. As might naturally be expected, without attention, the rapidly vibrating

parts will often work out of adjustment thereby spoiling the effect of the entire sign.

In general the skyrocket, crawling snake, or script writing effects are the most expensive in both flasher and wiring while the continuously moving border or the simple on and off effects are the easiest to obtain.

Too much attention cannot be given to the care or maintenance of an electric sign. A large investment may be robbed of the greater part of its earning capacity by neglect. A sign that is not clean and bright and in which the lamps are not all active or one in which a word is spelled out unevenly or with one letter omitted is a liability rather than an asset. Proper provision should always be made for maintenance with the same care as for installation.

The discussion of the roof sign has included many items which pertain to all kinds of signs. There are some features of construction, however, which are very different in signs used for other purposes.

The sidewalks or street signs as they may be called are so much nearer to the observer that the matter of detail must be given close attention.

This class (see Figs. 3 and 4) usually has an internal frame of steel, sufficiently rigid to prevent the buckling of the face under fairly heavy stress. The faces or sides are secured to the frame near the edges and frequently across the middle especially when a large number of sockets weakens the face.

The varieties of ornamentation are innumerable. The most common include the raised mouldings and the use of gold leaf.

On these flat sign bodies, the illuminated letters (see Fig. 7) are flush, raised, skeleton letter, trough or sunken, but in each case the sockets are inserted in the letter stroke to make the reading matter stand out. The use of color caps and hoods is common as with roof signs.

Porcelain enameled steel has been found very satisfactory as a sign material. The surface is an excellent reflector and can be very easily cleaned. The letter stroke is often made of enamel even when the body of the sign or letter is painted steel.

In one special form of construction (Fig. 5) each letter is made of an embossed porcelain enameled steel plate. The form of the plate is such as to give strength to the sign and allow the use of a neat narrow steel frame not over 2 in. in width.

In another familiar form of street sign (Fig. 8) a border of lamps

is provided around the reading matter or design. Where the lamps are raised perceptibly above the panel surface by the use of a special frame or otherwise the illumination of the panel is usually quite satisfactory, but where the socket is inserted flush with the sign face very poor results are obtained. All the slight imperfections in the surface are brought out. Again the angle of incidence is so large that very little light is reflected toward the observer.

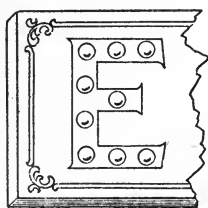

Type A

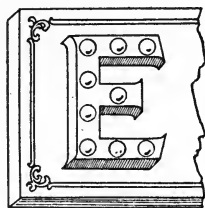

Type B

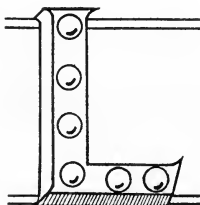

Type C

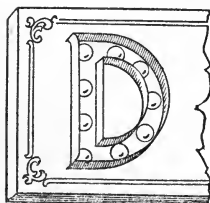

Type D

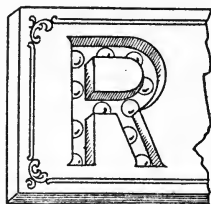

Type E

Fig. 7.—Type A, flush. Type B, raised. Type C, skeleton. Type D, trough. Type E, sunken grooved.

Many forms of transparencies are used for street signs (Fig. 9). As a class they are of little value from the standpoint of street illumination but they are often very pleasing in appearance and have their field. In this class are the lens sign (Fig. 13) the perforated or cutout letter, the canteen and the ornamental glass types.

As a class almost by themselves are the changeable letter signs (Fig. 10). Many of these, used principally for theatres, are so constructed that the individual letters may be easily removed and replaced for a change of reading. Even in the transparencies there are changeable letter types. For general advertising, there are

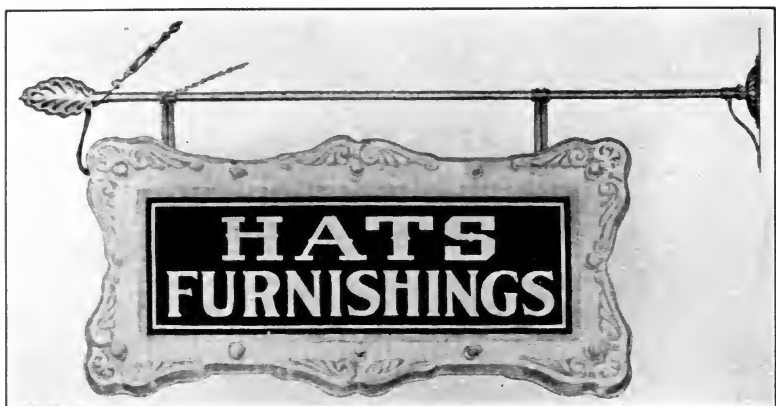

Fig. 8.—Panel sign.



Fig. 9.—Transparency.



Fig. 10.—Changeable letter sign.

(Facing page 540.)





Fig. 11.—Motograph.



Fig. 12.—Miniature lamp letter.

others which change automatically from one reading to another until quite a story may be told.

A late form of changeable letter sign which combines the changeable feature with a fascinating moving effect is the motograph (Fig. 11). In this sign, the letters appear on the right and move evenly and rapidly across the face as though attached to a belt. To produce this effect a large number of lamps arranged in horizontal and vertical rows in a lamp bank on the sign face are connected individually with contact brushes arranged in the same order but very close together in a brush board in the control machine. A perforated ribbon something like the roll in a piano player is drawn continuously across the brush board. Any figure such as a letter perforated in the ribbon will appear on the lamp bank. The brushes make contact through the perforations with a fixed metal plate

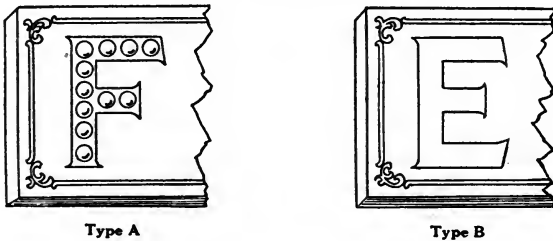

Fig. 13.—Type A, lens sign. Type B, cut out glass letter sign.

closing the electrical circuit and lighting up the proper lamps to form the letters.

A careful observer of this sign will note that the vertical strokes of the letters do not appear as bright as the horizontal strokes. The contacts controlling the lamps are made and broken so quickly that the lamp filaments do not reach their full brilliancy. If the observer is quite near the sign he will note a slight blur or streak, an effect like the tail of a comet following each letter across the sign, because filaments do not lose brilliancy fast enough. If there could be found a lamp in which the filament came to its full brilliancy and cooled off more rapidly than in the present standard tungsten lamp the speed of the sign could be materially increased.

Indoor Signs including the more common types of window signs are usually transparencies but one or two very attractive special types have been developed such as the miniature lamp letter sign, Fig. 12. Each letter is in itself a lamp. It is formed by bending a glass tube into the form of the letter and then inserting

small filaments at frequent intervals. These filaments are connected in series thereby enabling each lamp letter to be connected across the ordinary service wires.

Flood lighting of signs is a new development of the art. Under certain conditions the effects obtained are very satisfactory.

The flood of light illuminates everything in its field, the iron framework as well as the letters. For this reason flood lighting would seem to be better adapted to the illumination of large solid areas such as wall signs, buildings or bulletin boards than skeleton types of signs.

The flood lighting reflectors in sign work, therefore, supplant the bulletin board reflectors rather than the lamp letter signs.

#### ENGINEERING FEATURES

Except in the case of transparencies and possibly bulletin board lighting the development of the electric sign has depended upon the development of the sign lamp.

When the standard lamp available was the 16 c.p. carbon filament unit consuming as much energy as the 50-watt lamps of to-day and the cost of energy was many times as high as now, the electric sign of large size was out of the question. Again, the large size of the available lamp bulbs made a neat well-proportioned sign impossible in the smaller sizes. The development of the 8-c.p. and then the 4-c.p. carbon lamps made in the small bulb for sign use gave some encouragement but even then the panel or border lamp signs with their comparatively small number of lamps were the popular types on account of the expense.

All of the early lamps were used at the regular service voltage and consumed considerable energy. Reducing the diameter of the filament to reduce the current consumption made the lamp too frail. It was then found that by cutting the 4-c.p. 110-volt filament in half, two lamps of 2 c.p. each could be made to be used in series. The appearance of this new lamp about 1903 made it possible to form properly letters by using enough lamps and without too much expense although the signs were not equal to the brilliant present-day standard.

In experimenting with the 55-volt lamps in signs previously made for 110 volts it was found necessary to rewire the sockets two in series—an expensive process. The adoption of a new plan in sign wiring called the series-multiple system solved this difficulty. Two

equal banks of lamps as in the two sides of a double-faced sign were connected in series.

The arrangement called series-multiple wiring meaning a series of multiples is apt to prove perplexing to the wireman especially when there are several circuits on the same sign but with all its disadvantages the system has been thoroughly worth while for those who understood it as its use means a large saving in energy cost.

The 2-c.p. 55-volt carbon lamps consumed from 10 to 12 watts each. When the tungsten lamps with a large reduction in consumption were produced the sign industry naturally was eager to take advantage of the saving.

To put out a lamp with a filament sufficiently fine to hold the consumption below 10 watts on 115 volts was apparently impracticable especially with the delicate tungsten filaments; the 5-watt 10-volt sign lamp which was announced in Jan., 1909, was the result. The wiring for this lamp was arranged on the multiple system with a transformer when alternating current was used, although due to the half ampere current consumption per lamp the heavy currents at low voltage meant considerable loss in voltage drop and, therefore, in lamp brilliancy. With direct-current special wiring was imperative and naturally the series-multiple system employed with the 57-volt carbon lamps was arranged to include 10 or 11 groups in series. Where the sign was small each bank had only a few lamps, thus causing too great a stress on the remaining lamps when one or more burned out. Hence for small signs the series wiring was used with 10 or 11 lamps in each series. While the series system is the most economical from the standpoint of lamp renewal cost, it is very unsatisfactory in large signs because such a large portion of the sign is placed in darkness whenever any one lamp fails. In large signs where it is to be expected that one or more lamps will burn out frequently the sign would be constantly spoiled in appearance if the series wiring system were used, and hence the series-multiple system is employed where the number of lamps per circuit runs over 100.

With the series-multiple system using 5-watt 10-volt lamps it is possible without putting over 15 amperes on a circuit to include 330 lamps on a single circuit and thereby reduce the amount of wiring.

The appearance of the 10-watt 110-volt, and the 5-watt 55-volt sign lamps in June, 1912, and of the 7.5-watt 110-volt lamp in Sept., 1915, made it possible to eliminate the more complex series-multiple wiring without increasing the current consumption. At this date,

however, the 5-watt 10-volt lamp is still very widely used on account of its ruggedness.

An important problem related to sign design is that of legibility. The size, shape, spacing, and brilliancy affect the readability to a marked degree. Many signs that are otherwise well made are absolutely unreadable even from a moderate distance. This feature must receive attention.

#### THE ELECTRIC SIGN AS A LIGHT SOURCE

The illumination produced in its vicinity by the average, fair-sized electric sign should not be overlooked as it is a point in its favor. In exterior illumination the electric sign as a light source gives ideal results. The lighting of a street with large numbers of small candle-power lamps would be out of the question because of the high cost of such a method. However, when merchants along any good business street make use of a quantity of properly designed signs, that street needs no other illumination, and is the best and the most satisfactorily lighted street in the city. The signs need not necessarily project even over the sidewalk. The sidewalks can be clear of lamp posts, while the illumination is pleasing and adequate.

It frequently happens in a poorly lighted district that the electric sign on the corner drug store stands out as the only bright spot. Its cheering influence is unconsciously appreciated by all.

#### THE ELECTRIC SIGN INDUSTRY

It is estimated that there are approximately 15,000 electric signs in New York City and 10,000 in Chicago. In many small cities there are more signs per capita than in either of these.

If we consider only the cities and towns in the United States with a population of over 5000 and assume that the number of signs per capita is 80 per cent. of the New York average there would be a total of 240,000 signs in this country.

In an ordinary installation, the principal items of cost are the sign proper or the sign body; the hanging and wiring; the lamps, color caps and flasher and the permits.

The average total cost might be taken as \$65. The capital invested in electric signs would then be about \$15,600,000.

It is probable that this is considerably underestimated as many roof signs cost between \$5000 and \$10,000 each. The lamp investment alone is about \$4,000,000.

The average power consumption per sign in Chicago is 760 watts.

The rated sign load for the country on this basis would be 182,000 kw. and at 5 cents per kw.-hour with a four-hour service period per day the energy used would bring a return of \$11,000,000 per year to the central stations.

It is estimated that the sign business has not been developed to 20 per cent. of what it should be. If properly developed the estimates given would be multiplied by 5.

To realize what the electric sign business means to other industries consider one class of signs, the roof signs, and note the material and labor involved.

One thousand roof signs averaging 40 ft. high by 50 ft. long would require:

7500 tons of steel @ \$200 = \$1,500,000 installed.	
1,000,000 sign lamps... \$160,000	} \$357,000 in electrical supplies.
3,000,000 ft. of wire... 40,000	
1,000,000 sockets..... 50,000	
10,000 lbs. of tape..... 2,000	
500,000 ft. of conduit..... 35,000	
10,000 gal. of paint..... 70,000	

besides 30,000 flashers, 20,000 time switches, 5000 meters, 2000 transformers, many cutouts, fuse plugs, color caps and probably about 600,000 board ft. of platform lumber.

The labor cost for designers; sheet metal workers, painters, electricians, structural iron workers, teamsters and roofers costs about \$675,000. The railroads get about 2,200,000 ton-miles of freight. One sign manufacturer alone pays \$36,000 a year for freight.

The figures above apply to only a portion of one class of signs. Another class, the porcelain enamel steel signs, would keep an immense enameling factory busy, while the many varieties of glass signs mean a large glass business. One sign company alone employs upward of fifty traveling men continually throughout the year. Much more data could be presented to show the extent to which the application of artificial light to the illuminated sign has been carried. Sufficient has probably been given to indicate in a general way the extent to which the art has been developed.

#### ORDINANCES

Having in mind the size of the electric sign business one realizes that those who advocate abolishing signs altogether are hardly apt to succeed, at least without a long fight and a hard one.

For the good of the industry itself, however, as well as to meet the radicals part way, certain consideration should be given to the size, type and location of signs. Proper ordinances should be enacted and enforced to prevent the installation of a huge ungainly and possibly dangerous street sign. Municipalities are considering this subject with more and more care. Probably the majority of towns and cities of over 5000 population now have sign ordinances. Unfortunately many of the ordinances seem to have been introduced with the object of discouraging the industry rather than of controlling it. It is important to use a proper hanging rig with a street sign including sufficiently heavy chains and cables and adequate wall attachments. A wise manufacturer will make these parts unquestionably strong, and a wide-awake city inspector will see that they are properly installed.

#### THE EFFECT OF THE ILLUMINATED SIGN ON A COMMUNITY

From what has been said in reference to street illumination alone, a strong argument can be made for the illuminated sign. This point is relatively unimportant, however, as the big value of illuminated signs to any community lies in their wonderful brightening, boosting and cheering influence. Compare any two towns with and without these signs. The one is alive while the other is dead. The merchant, the real estate man, the politician, everyone realizes what it means to a town to have the reputation of being alive. Certainly it means enough to warrant a place in any list of industries of the country.





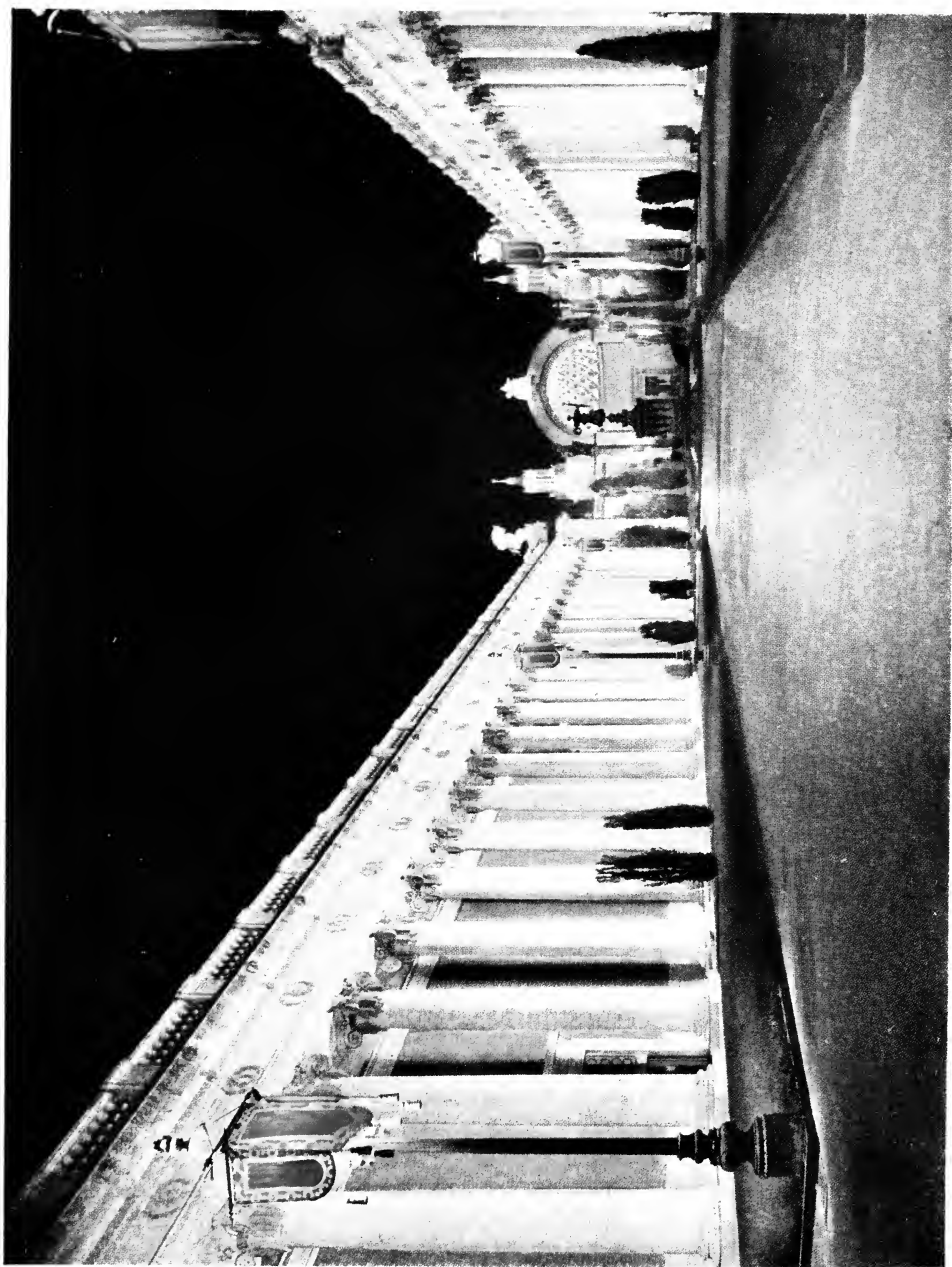



**COLONNADE APPROACH TO THE COURT OF FOUR SEASONS**

This view illustrates the complete concealment of column cusps for the wall lighting, and also shows the luminous arc banner standards used for facade lighting.

## BUILDING EXTERIOR, EXPOSITION AND PAGEANT LIGHTING

BY W. D'A. RYAN

Since the days of the cave man, fire or light has been a factor in all festivities. The victories of the barbarians were usually celebrated at night around the blazing camp fires. The war dance of the American Indian would not have been complete without fire.

Decorative lighting for commercial purposes originated with the Chinese. They employed paper lanterns in festooning, and gas jets in accentuating the architectural lines of their shops and buildings. The celebrations of all ages, when carried into the night, have called for additional lighting, both for utilitarian and spectacular purposes. Prior to the advent of electricity such lighting was accomplished mainly by gas jets and fireworks.

Systems of illumination falling within the classification forming the title of this lecture differ from utilitarian lighting systems in that efficiency of light production assumes a secondary rôle. The important point to keep in mind in planning lighting schemes of this character is the necessity for conforming to the architectural ideas or at least to accomplish the lighting results without conflicting with the architecture. To do this successfully requires coöperation between the architect or decorator and the illuminating engineer to a much greater degree than is common practice to-day. The lighting features should receive study from the time of the conception of the architectural details and be developed along with the structural plans. Of course many creditable lighting installations have been made in buildings which were completed before the lighting was considered, but such procedure is a mistake when it is possible to develop the illumination plans in parallel with the architectural plans.

All architecture is created primarily for observation in daylight; therefore, if we are to retain the architectural details of a structure when viewed by artificial light we must approximate daylight conditions. Daylight consists of a strong directional light from the sun supplemented by diffused light from the clouds; the former creates sharp shadows, and the latter relieves them to a greater or less extent.

A total absence of sunlight (unidirectional light) would create a shapeless monotonous mass because there would be no shadows, while a total absence of reflected light (diffused light) would create extreme high lights and harsh shadows. A combination of these two kinds of light is, therefore, necessary to give proper perspective to architectural forms, and if we are to be successful in displaying the work of artists and architects by artificial light we must approximate the distribution found in nature, that is, a strong directional light coming from above if possible and supplemented by relief lighting.

For a good many years the only method employed in lighting a building for emphasis was outline lighting, that is, locating rows of incandescent lamps around the cornices, windows, etc. This method is still used for amusement parks, motion picture theatres, etc., but is too closely akin to the bizarre for our modern monumental and commercial buildings. In such a scheme of lighting the building merely serves as a background upon which to display lamps and when the lamps are lighted only a skeleton of light appears and the building is obscured by the glare. Its other disadvantages are the diminution of artistic effectiveness at close range, similarity of effects from different view points, the suppression or complete obliteration of architectural features, the economic necessity of extensive untreated surfaces and severe eye and nerve strain resulting from the glare.

Very little can be stated in the way of concrete rules covering spectacular lighting. Such lighting depends for its success on an appeal to the senses in which respect it is similar to paintings and music. Light, color and motion are essential features in any spectacular display and by arranging them in interesting combinations many varied and beautiful effects may be obtained. Steam, vapor and water afford excellent reflecting media upon which to play light. Color always adds interest and is readily obtained by passing white light through light-absorbing gelatine sheets or colored glass. The illuminating engineer must use his own ingenuity in devising spectacular lighting features.

#### EXPOSITION LIGHTING

In our study of the lighting treatment of expositions, it is well to review briefly the methods and results of former expositions. From such a study we learn that after the introduction of electricity

**SOUTH WING, PALACE OF FINE ARTS**

An artistic setting illustrating the preservation of detail in light, shadow and color under artificial light.

Artistic  
lighting  
of  
interior

directional light) would create a  
... there would be no shadows,  
... light (diffused light) would create  
... shadows. A combination of these  
... necessary to give proper perspective  
... are to be successful in displaying  
... by artificial light we must approach  
... nature that is, a strong directional  
... supplemented by relief

An artistic setting illustrating the preservation of detail in light  
showing color under artificial light  
SOUTH WING, PALACE OF FINE ARTS

... method employed in lighting  
... lighting, that is, locating rows  
... lines, windows, etc. This  
... in a picture, the eyes  
... modern requirements  
... of lighting the  
... display cases  
... light appears too  
... other disadvantages are  
... at these angles, similarity of  
... or complete relief  
... necessity of erecting  
... strain resulting

... of concrete lines covering  
... for its success in an  
... is similar to paintings and  
... to be in any pro-  
... combination  
... Steam vapor  
... to play light  
... of relief, by passing  
... sheets of colored glass  
... generally to avoid a

... study  
... rely  
... study

...  
...  
...

...  
... of expositions it is well  
... of former exposition  
... introduction of electric

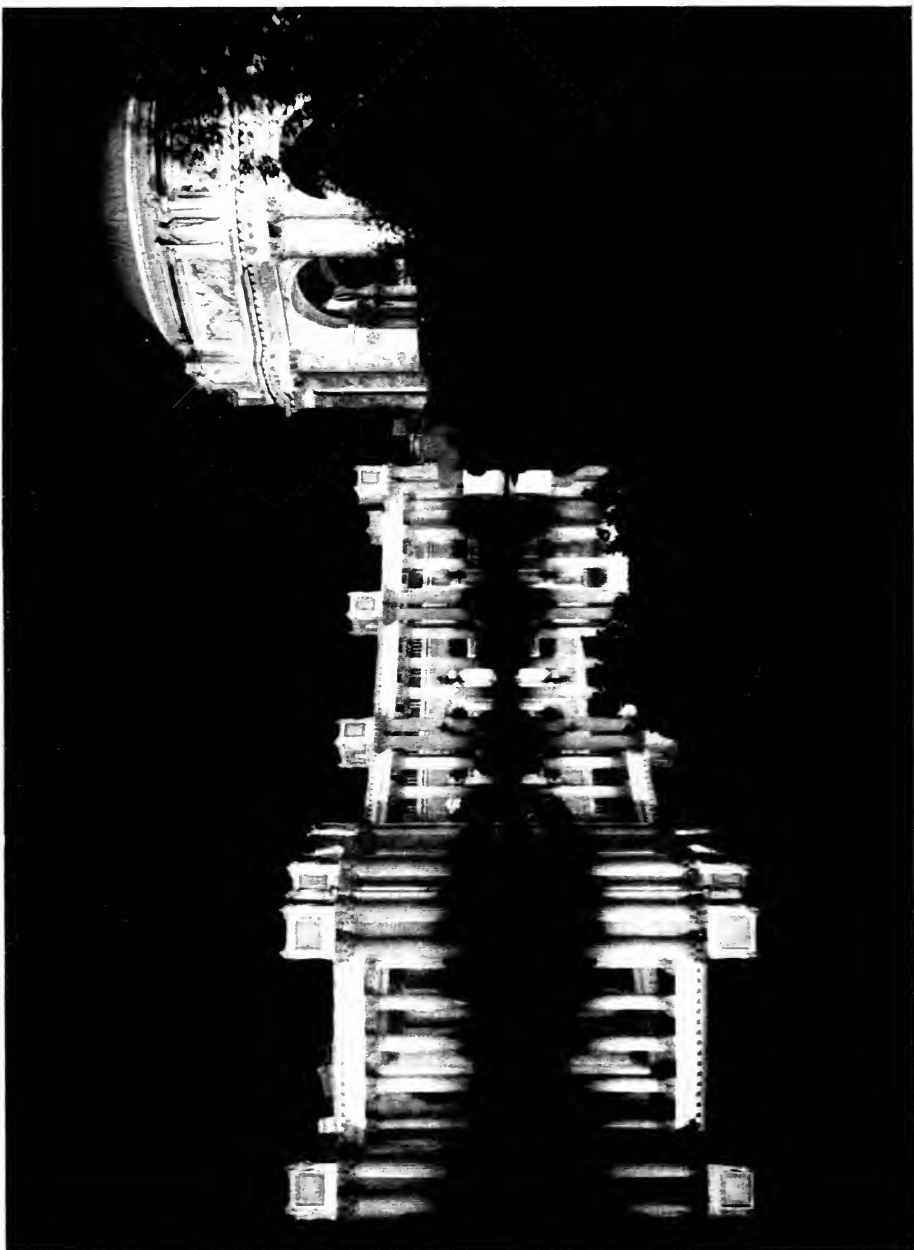





**WEST FACADE, PALACES OF EDUCATION AND FOOD PRODUCTS**

**Fog accounts for the prominence in this photograph of the light beam from the scintillator.**

For accounts of the prominence in this biography of the light seen from the scintillator.

WEST ELYSDE, BYTVCS OF EDNCATION AND FOOD PRODUCLZ

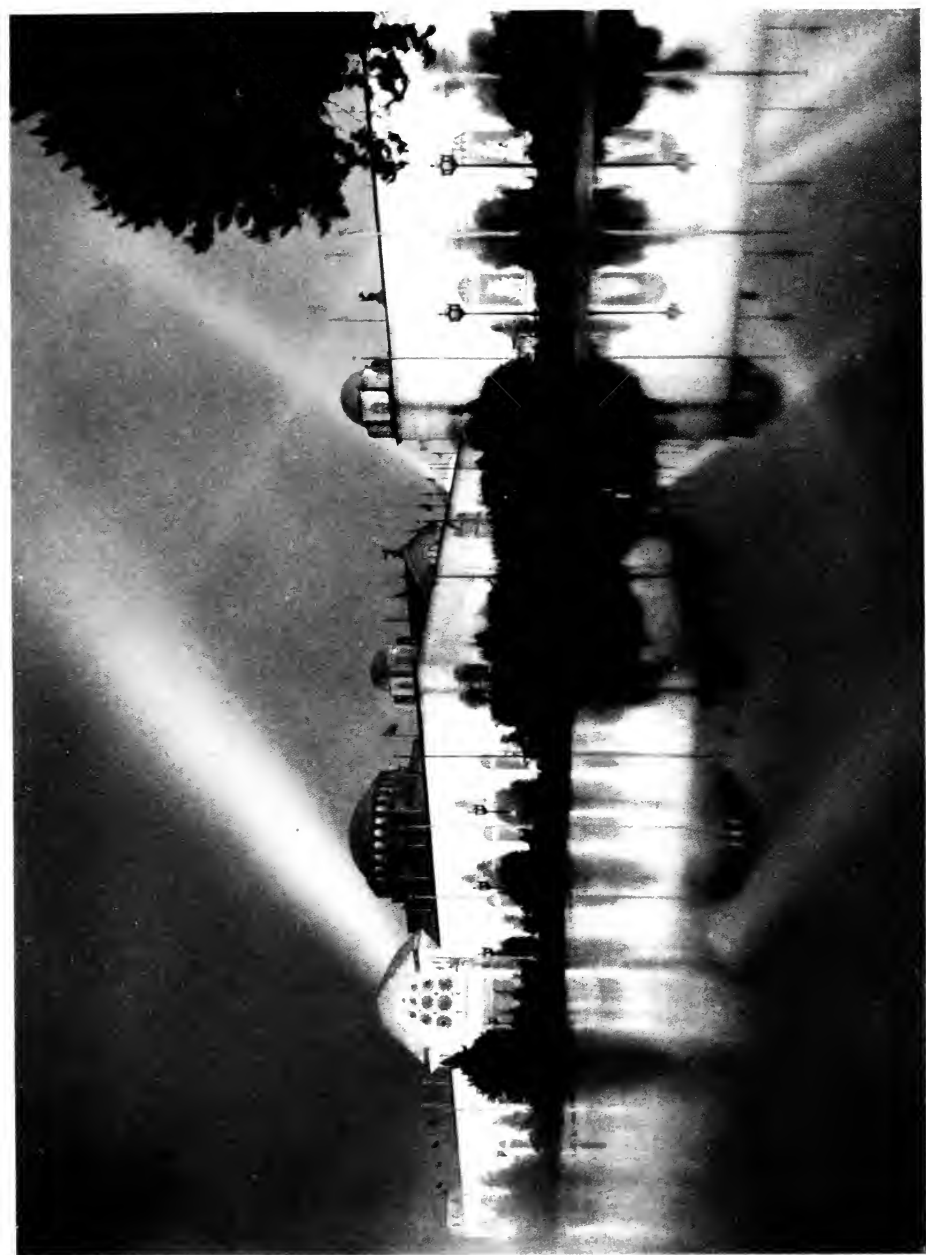



for illumination purposes at the Louisville, Ky., Exposition in 1883, outline lighting has characterized all expositions prior to the Panama-Pacific International Exposition in 1915. The exposition at Louisville was notable for two reasons, first because a method of bringing the lighting up from zero to full candle-power was introduced, and secondly because it was the last exposition in this country where gas was utilized in the plans for the main portion of the lighting.

In the Court of Honor at the Columbian Exposition, Chicago, 1893, outline lighting with incandescent lamps was used extensively while arc lamps and ornamental posts were employed for the lighting of the grounds. An electric fountain and the Edison Tower forming part of the exhibit of the General Electric Company and made up of 10,000 16-c.p. carbon-filament lamps were the spectacular features.

The first complete method of decorative and grounds lighting by incandescent lamps was at the Mississippi and International Exposition, held at Omaha, in 1898. The illumination received the highest award at this exposition.

At the Fourth Universal Exposition held at Paris in 1900 was found a mixture of all types of illuminants; incandescent lamps predominating with a total of 76,720 used for decorative purposes. The Electricity Building and the Eiffel Tower were the principal features. The crest of the Electricity Building was covered by the "Great Star" placed behind the figure of Marqueste, the genius of electricity. The star had 68 points made up of gilded tubing and was lighted from the rear by six 60-amp. projectors. Electric fountains illuminated by arc and incandescent lamps equipped with color screens were used. Other lighting features were the Palace of Optics with 14,000 16-c.p. and 32-c.p. lamps, the Palace of Light with 12,000 lamps, Monumental Gate with 1385 incandescent lamps in colored globes and the Trocadero Palace festooned with thousands of gas jets.

At the Pan American Exposition, held at Buffalo in 1901, incandescent outline lighting probably reached its maximum effectiveness. Incandescent lamps of low candle-power were used exclusively and the number of lamps was gradually increased so as to form a climax at the Tower.

At the Louisiana Purchase Exposition of St. Louis, 1904, because of its size, the ideas carried out at Buffalo could not be adopted, so it was necessary to spread out the lighting to a certain extent and accentuate certain prominent features. All of the main build-

ings were lavishly festooned with incandescent lamps. Each lighting unit along the colonnade was provided with three lamps, white, emerald and amethyst, each color on a separate circuit. Water rheostats were used for dimming each color and to bring the general illumination gradually up to full candle-power. Arc lamps were employed throughout the grounds and Nernst lamps were used in the Exposition buildings. The monumental feature of the Exposition was the Cascades, illuminated by incandescent lamps.

At the Lewis and Clark Exposition at Portland, Oregon, in 1905 incandescent lamps were used exclusively. One of the features of the Exposition was the illumination of the lake. Around the lake 50-c.p. lamps were placed in marine receptacles on the bottom of the lake at intervals of three feet.

At Jamestown in 1907 the decorative lighting of the buildings was done with 8-c.p. lamps placed on approximately 12-in. centers. A water rheostat of 2500-kw. capacity was used to "build up" the lighting. Four minutes were allowed for the lamps to reach their normal candle-power. One of the illuminating features was the Administration Building with the projector beams forming a fan behind the dome. Another pleasing feature was Flirtation Walk where flashing lamps were placed in trees and shrubbery to give a firefly effect.

One of the best examples of outline lighting as it should be employed for exposition buildings was shown at the Alaska-Yukon Pacific Exposition in Seattle in 1909. A total of 250,000 lamps was used there for all purposes. For decorative purposes 8-c.p. all frosted carbon lamps were employed. The grounds were lighted by 200 special electroliers, each containing 39 20-c.p. lamps.

Gas was found admirably suited to outline the buildings at the coronation in London, 1910. The effect produced, because of the continual flicker of the light, was interesting and lively.

The illumination of the Panama-Pacific international Exposition represented the latest developments in exposition lighting and marked an epoch in the science of lighting and the art of illumination. Previous expositions had depended upon outline lighting for night effects and this method had probably reached the limit of its possibilities at the Pan-American Exposition at Buffalo. The outline method, therefore, was set aside and a system of screened or masked flood and relief lighting was employed.

During the period elapsing between the Louisiana Exposition and the Panama-Pacific International Exposition wonderful advances

**LAGOON, SOUTH GARDENS**

**Festival Hall on the right and the towers at the approach to the Court  
of Flowers at the left.**

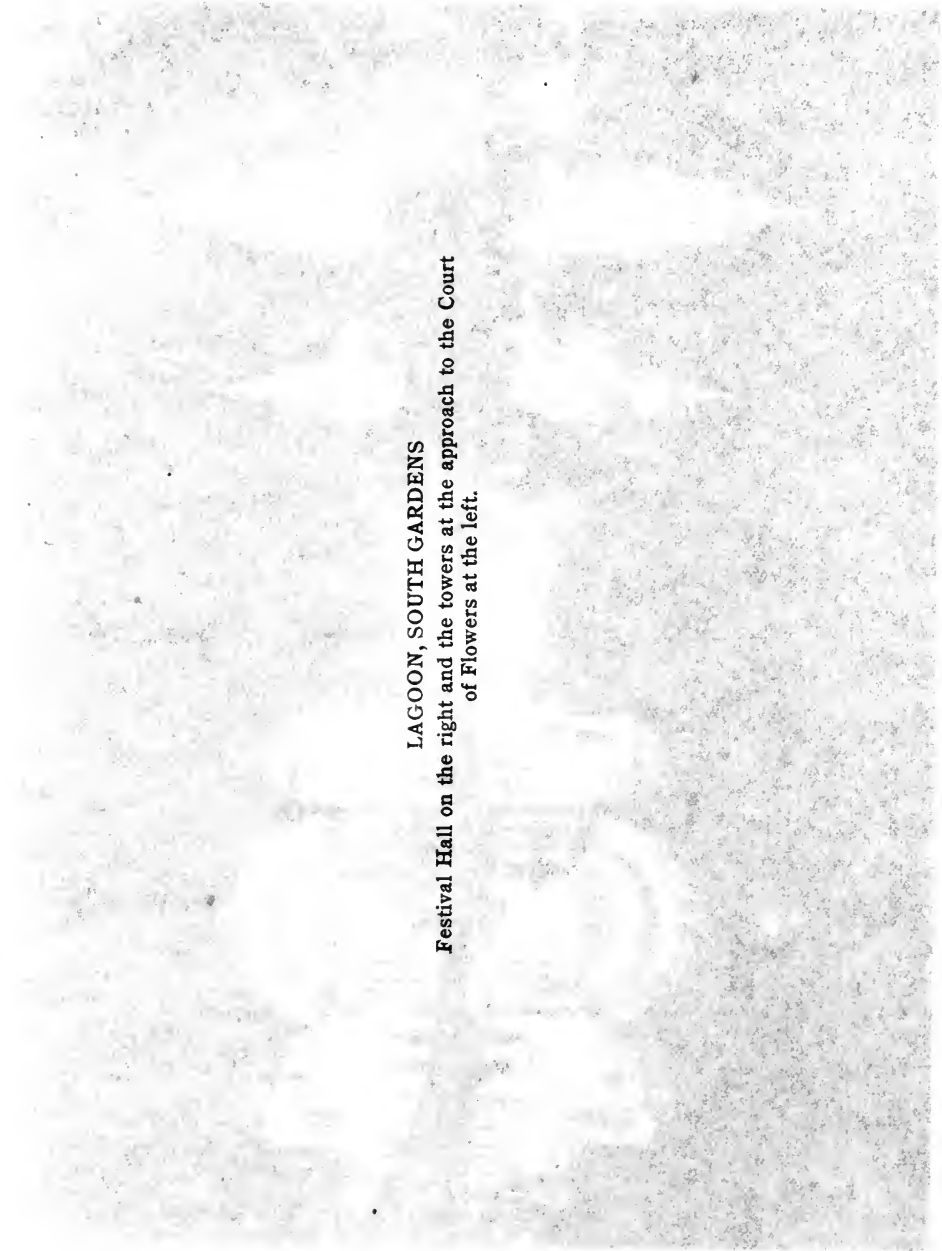





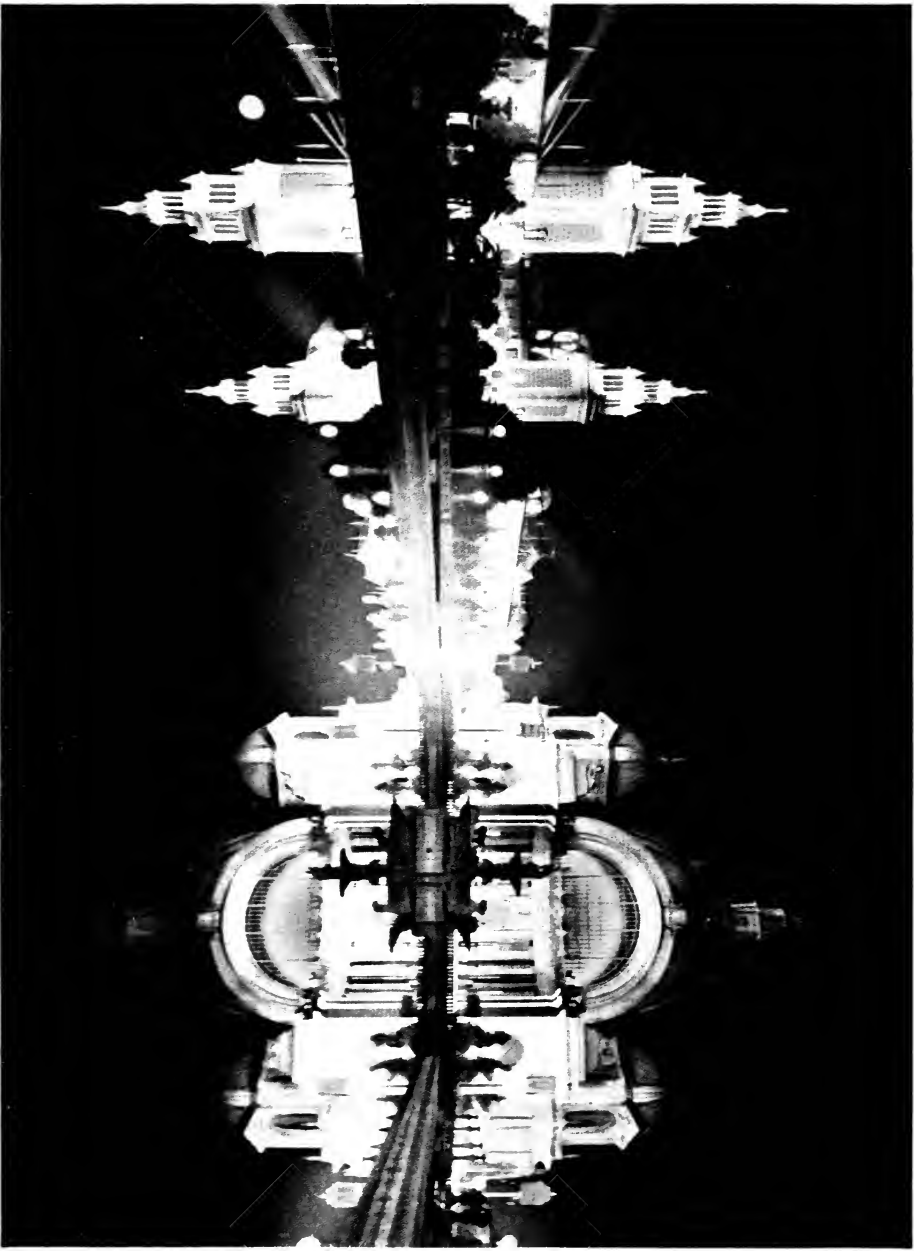



#### COURT OF THE UNIVERSE—NIGHT VIEW

Lighted chiefly by two standards or columns 95 feet high and containing incandescent lamps aggregating approximately 500,000 candlepower and lighting approximately equal horizontal and vertical areas. In the daytime these lighting standards appeared as solid travertine columns, thus acquiring an effect of architectural strength. The lamps of the Atlantes which mark the perimeter of the Sunken Garden were for ornamental purposes only and did not add materially to the illumination of the Court.

illumination of the Court.  
which mark the perimeter of the Zinken Garden were for ornamental purposes only and did not add materially to the strength of the structure. The marks of the structure were approximately 200,000 centimeters and lighting approximately equal horizontal and vertical lighted chiefly by two standards of columns of feet high and containing incandescent lamps aggregating

COPIES OF THE UNIVERSE—MIGHT VIEW

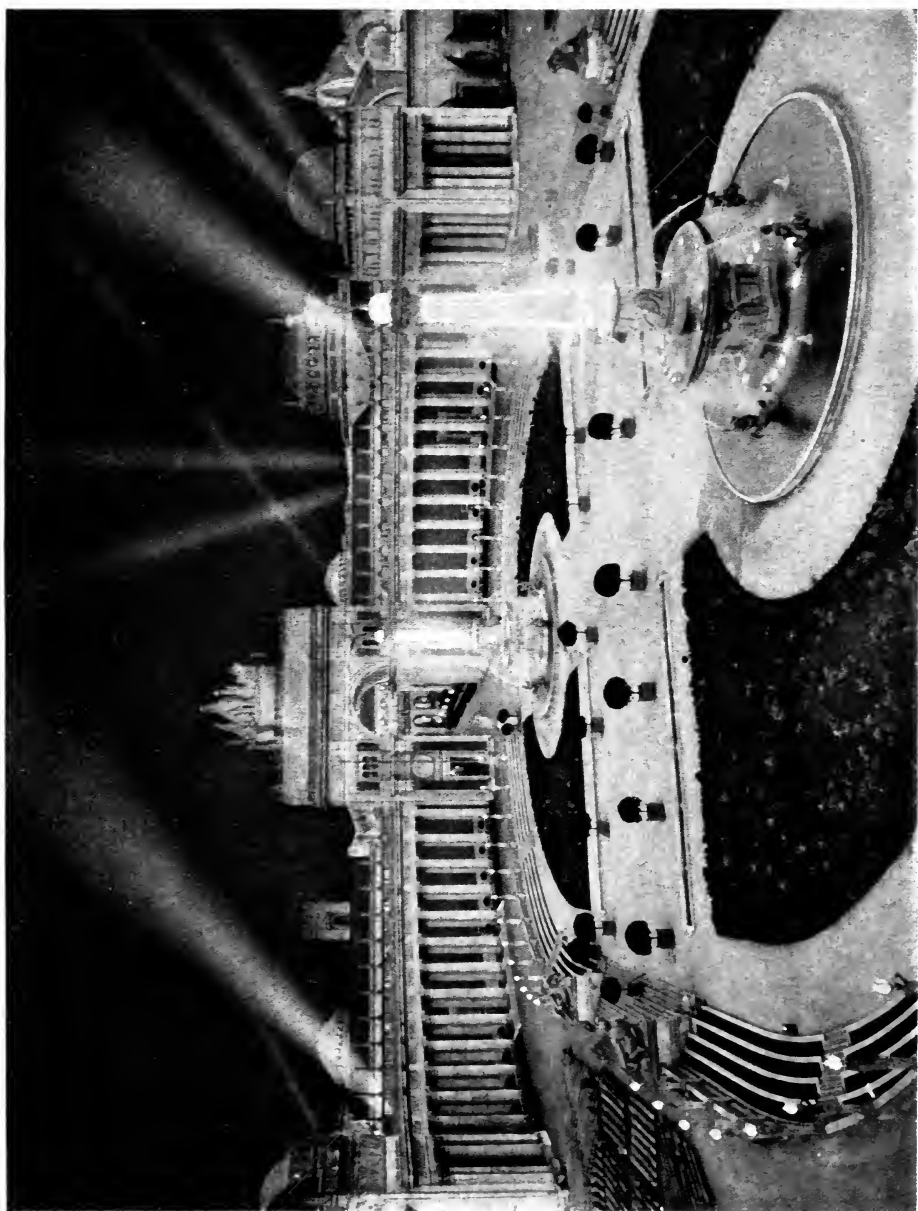



had been made in the efficiencies of all types of lighting units. Thus it was possible to illuminate, in the main groups of buildings and grounds, approximately 8,000,000 sq. ft. of horizontal and vertical surfaces with intensities ranging from 0.1 to 0.25 foot-candle in the incidental gardens and roadways, from 0.25 to 3 foot-candles on the building façades and adjacent lawns and gardens, and from 5 to 15 foot-candles on the towers, flags and sculptural groups. The lighting load on the main group of buildings, including the window lighting and the scintillator, was approximately 5000 kw. The total connected load for all purposes, including the "Zone" foreign and state sections and exhibitors, for lighting, incidental heating, motor, and other service was 13,954 kw. with a maximum peak of 8200 kw. and an average peak of 7880 kw.

While the lighting of the Exposition was primarily electric, all modern light sources of intrinsic merit were utilized, and a number of excellent gas features were introduced. About four miles of streets in the foreign and state sections were illuminated with high pressure "gas arc lamps" equipped with 20-in. opal globes mounted with their centers about 16 ft. above the roadways on ornamental poles spaced approximately 100 ft. apart, staggered. The same type of lamp was used for emergency lighting on the kiosks throughout the grounds. Five-mantle "enclosed gas arc lamps," in the "Zone" section and the same type of lamp, in smaller sizes, furnished emergency lighting at the gates and important exits from the main group of buildings. Gas flambeaux were introduced in the effects in the "Court of Abundance" and the "North Approach." The total gas flow for the purposes mentioned was approximately 15,000 cu. ft. per hour.

Furnishing wonderful contrast to the soft illumination of the palaces, was the "Zone" or amusement section, with all the glare of the bizarre, giving the visitor an opportunity to contrast the illumination of the future with the light of the past. As we passed from the "Zone" with its blaze of light, we entered a pleasing field of enticement. We were first impressed with the beautiful colors of the heraldic shields, on which were written the early history of the Pacific Ocean and California. Behind these banners were luminous arc lamps in clusters of two, three, five, seven and nine, ranging in height from 25 to 55 ft. We looked from the semi-shadow upon beautiful vistas and the Guerin colors, which fascinating in daytime, were even more entrancing by night. The lawns and shrubbery surrounding the buildings and trees with their wonderful shadows appeared in



magnificent relief against the soft background of the palaces. The "Tower of Jewels" with its 102,000 "Novagems," which suggested the official title "Jewel City" standing mysteriously against the starry blue-black of the night, might be said to have surpassed the dreams of Aladdin.

The Courts of Flowers and Palms each received treatment in keeping with its oriental architecture. The towers were flood lighted by arc standards and projectors and the shadows thus created were illuminated with colored light at the various levels.

In the Court of Flowers the incandescent standard and lantern served to give a subdued illumination throughout the court. The balustrade standard in the Court of Palms was equipped with a 20-in. glass sphere and the Colonnade was lighted by large staff hanging basket fixtures.

As we passed through the approach to the "Court of Abundance" from the east, with its masked shell standards strongly illuminating the cornice lines and gradually fading to twilight in the foreground, and entered the Court, we were impressed with the feeling of mystery analogous to the prime conception of the architect's wonderful creation. Soft radiant energy was everywhere; lights and shadows abounded, fire hissed from the mouths of serpents into the flaming gas caldrons and sent its flickering rays over the composite Spanish-Gothic-Oriental grandeur. Mysterious vapors rose from steam-electric caldrons and also from the beautiful fountain group symbolizing the earth in formation. The cloister lanterns and snow-crystal standards gave a warm amber glow to the whole Court, and the organ tower was illuminated in the same tone by colored projector rays.

Passing through the "Venetian Court" we entered the "Court of the Universe," where the illumination reached a climax in dignity thoroughly in keeping with the grandeur of the Court. Here an area of nearly half a million square feet of horizontal and vertical surface was illuminated by two fountains rising 95 ft. above the level of the sunken gardens, one symbolizing the rising sun and the other the setting sun.

The shaft and ball surrounding each fountain was glazed in heavy opal glass, which was coated on the outside in imitation of travertine marble, so that by day they did not in any sense suggest the idea of light sources. High efficiency incandescent electric lamps installed in these two columns gave a combined initial (bare lamp) candle-power of approximately 500,000 and yet the intrinsic brilliancy was



**COURT OF ABUNDANCE**

**Showing the Organ Tower and the fiery serpent flambeaux. The orange colored cloister lanterns, the flaring gas and ruby steam caldrons, and the torches on the tower combined to produce a feeling of mystery in this Court at night.**



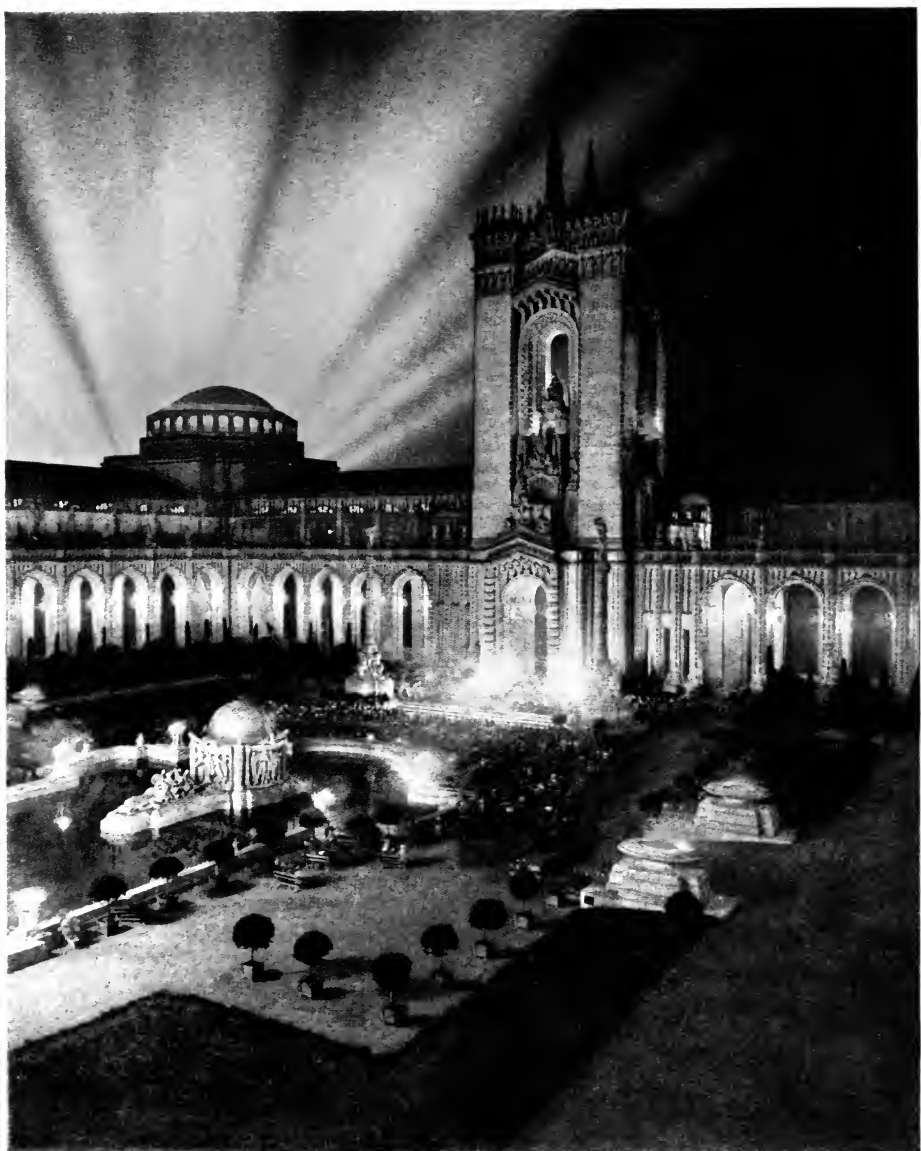



so low that the fountains were free from disagreeable glare and the great colonnades were bathed in a soft radiance. For relief lighting three incandescent lamps were placed in specially designed cup reflectors located in the central flute to the rear of each column. This brought out the Pompeian red walls and the cerulean blue ceilings with their golden stars, and at the same time the sources were so thoroughly concealed that their location could not be detected from any point in the court.

The perimeter of the sunken gardens was marked by balustrade standards of unique design consisting alternately of Atlante and Caryatides supporting an urn in which were placed incandescent lamps of relatively low candle-power. The function of these lamps was purely decorative.

The great arches were carried by concealed lamps, red on one side and pale yellow on the other, thereby preserving the curvature and the relief of the surface decorations. The balustrade of this court, 70 ft. above the "Sunken Gardens," was surmounted by 90 seraphic figures with jeweled heads. These were cross lighted by 180 incandescent projector lamps, the demarcation of the beams being blended out by the light of the fountains of the "Rising Sun" and "Setting Sun."

Passing through the "Venetian Court" to the west, we entered the "Court of Four Seasons" classically grand. We were then in a field of illumination in perfect harmony with the surroundings, suggesting peace and quiet. The high-current luminous arc lamps mounted in pairs on 25-ft. standards masked by Greek banners were wonderfully pleasing in this setting. The white light on the columns caused them to stand out in semi-silhouette against the warmly illuminated niches with their cascades of falling water, and the placid central pool reflected in marvelous beauty, scenes of enchantment.

Having reviewed in order the illuminations mysterious, grand and peaceful, we emerged from the west court upon lighting classical and sublime, the magnificent "Palace of Fine Arts" bathed in what might be called "Triple moonlight," casting reflections in the lagoon impossible to describe. The effect was produced by projectors located on the roofs of the "Palace of Food Products" and "Palace of Education" supplemented by concealed lamps in the rear cornice soffits of the colonnade.

Having passed through the central, east and west axes of the Exposition, there were many more marvels to be seen. If one had wished to study the art of illumination he could have visited the

Exposition every evening throughout the year and still have found detail studies of interest. For instance, he could have seen artificial illumination in competition with daylight. On certain occasions the projectors flood lighted the towers before the sun went down. If some were fortunate enough to have been present in the northwest section of the "Court of the Universe" and watched the marvelous effect of the "Tower of Jewels" as the daylight vanished and the artificial illumination rose above the deepening shadows of the night, they saw the prismatic colors of the jewels intensify and the "Tower" itself become a vision of beauty never to be forgotten.

At night the "South Garden" could very properly have been called the "Fairyland of the Exposition." When light was first turned on, the five great towers were bathed in ruby tones and they appeared with the iridescence of red hot metal. This gradually faded to delicate rose as the floodlight from the arc projectors converted the exterior of the towers into soft Italian marble. The combination of the light from the projector arc lamps (white) and that from the concealed incandescent lamps (ruby) produced shadows of a wonderful quality. Each flag along the parapet walls had its individual projector which converted it into a veritable sheet of flame. As a primary line of color the heraldic shields and cartouche lamp standards produced a wonderful effect against the travertine walls bathed in soft radiance from the luminous arc lamps, which also brought out the color of the flowers and lawns and created pleasing shadows in the palms and other tropical foliage. This was supported by a secondary effect in the decorative incandescent electric standards along the "Avenue of Palms" and throughout the gardens. A finishing touch was added by the effect of "Life within" created by the warm orange light emanating from all the Exposition windows supported by rose red light in the towers, minarets, and pylon lanterns.

To the west the enormous glass dome of the "Palace of Horticulture" was converted into an astronomical sphere with its revolving spots, rings and comets appearing and disappearing at the horizon and changing colors as they swung through their orbits. The action was not mechanical, but astronomical.

To the east the "Festival Hall" was flood lighted by luminous arc lamps and accentuated by orange and rose light from the corner pavilions, windows, and lanterns surmounting the dome. All of this view was reflected in the adjacent lagoon and possessed a distinctive charm which will long remain in the memory.

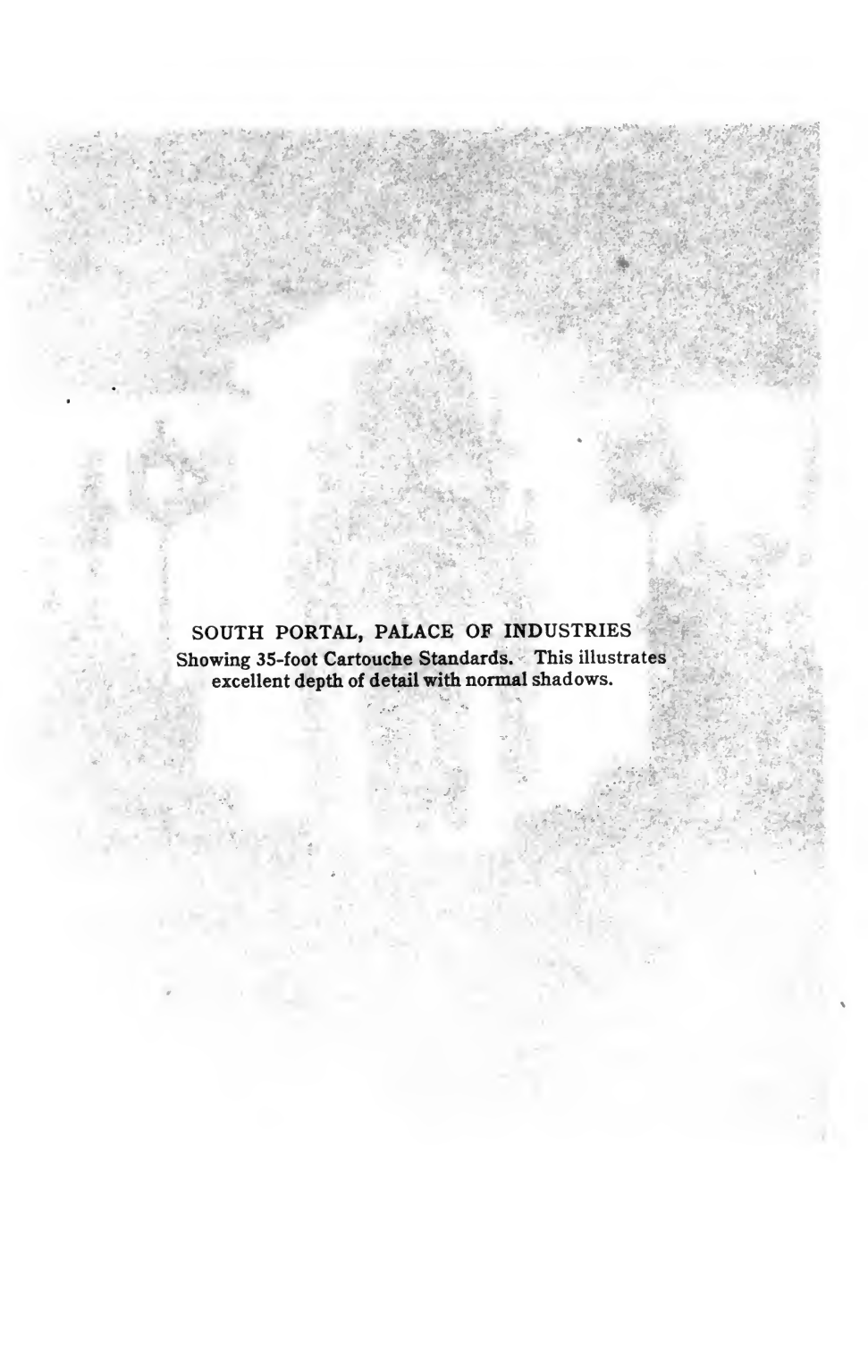

**SOUTH PORTAL, PALACE OF INDUSTRIES**  
Showing 35-foot Cartouche Standards. This illustrates  
excellent depth of detail with normal shadows.



Exposition was continuing throughout the year and still have found detail study of interest. For instance, he could have seen artificial illumination in sympathy with daylight. On certain occasions the projectors cast light on the towers before the sun went down. If some of the projectors had been present in the northwest corner of the "Palace of the Universe" and watched the marvelous effects of the "Tower of Jewels" as the daylight vanished and the projectors came into play above the deepening shadows of the night, the effect of the color of the jewels intensity and the "Tower of Jewels" would have been of beauty never to be forgotten.

The "Palace of Horticulture" could very properly have been illuminated in sympathy with the Exposition. When light was first cast on the towers they glowed in ruby tones and they gradually changed to a softness of yellow crystal. This gradually faded into the daylight as the arc projectors came into play and the towers faded into soft Italian marble. The towers were lit by arc lamps (white) and the effect of the projectors produced shadows

of the towers on the walls had the least of the shadows and cartouche

standards produced a wonderful effect against the travertine walls bathed in soft radiance from the incandescent arc lamps, which also brought out the color of the flowers and lawns and created pleasing shadows in the palms and other tropical foliage. This was supported by a secondary effect in the decorative incandescent electric standards along the "Avenue of Palms" and throughout the gardens. A finishing touch was added by the effect of "light within" created by the warm orange light emanating from all the Exposition windows superior to the red light in the towers, minarets, and pylon lanterns.

For the "Palace of Horticulture" the "Palace of the Universe" of the "Palace of Horticulture" was a globe with its revolving spheres and appearing at the horizon and only as they pass through their orbits. The effect was not merely a beautiful illustration.

To the east of the "Palace of Horticulture" was flood lighted by luminous arc lamps and accented by orange and rose light from the corner pavilions, windows, and lanterns surrounding the dome. All of this view was reflected in the adjacent lagoon and possessed a distinctive charm which will long remain in the memory.





Purely spectacular effects were confined to the scintillator at the entrance of the yacht harbor. This consisted of forty-eight 36-in. projectors having a combined projected candle-power of over 2,600,000,000. This battery was manned by a detachment of U. S. Marines.

A modern express locomotive with 81-in. drivers was used to furnish steam for the various fireless fireworks effects known as "fairy feathers," "sunburst," "chromatic wheels," "plumes of paradise," "Devil's fan," etc. The locomotive was so arranged that the wheels could be driven at a speed of fifty or sixty miles per hour under brake, thereby giving forth great volumes of steam and smoke which, when illuminated with various colors, produced a wonderful spectacle.

The aurora borealis created by the projector beams reached from the Golden Gate to Sausalito and extended for miles in every direction. The production of "Scotch plaids" in the sky and the "birth of color," the weird "ghost dance," "fighting serpents," the "spook's parade," and many other effects were fascinating.

Additional features consisted of ground mines, salvos of shells producing flags of all nations, grotesque figures and artificial clouds for the purpose of creating midnight sunsets.

Over 300 scintillator effects had been worked out and this feature of the illumination was subject to wide variation. Atmospheric conditions had a great influence upon the general lighting effects; for instance, on still nights the reflections in the lagoons reached a climax, particularly the "Palace of Fine Arts" as viewed from "Administration Avenue;" the facades of the "Palace of Education" and "Palace of Food Products" as seen in the waters through the colonnade of the "Palace of Fine Arts;" the "Palace of Horticulture" and "Festival Hall" from their respective lagoons in the "South Garden;" the colonnades and the Novagems on the heads of the seraphic figures and the "Tower of Jewels" as reflected in the water mirror located in the north arm of the "Court of the Universe."

On windy nights the flags and jewels were seen at their best. On foggy nights there were produced over the Exposition wonderful beam effects impossible at other times.

When the wind was blowing from the land the scintillator display was different from nights when the wind was blowing from the bay. A further variety was introduced in the action of the smoke and steam on calm nights.

On the evening of St. Patrick's day all the projectors were screened

with green, and not only the towers but every flag in the Exposition took on a new aspect.

Orange in various shades was the prevailing color for the evening of "Orange Day," and on the ninth anniversary of the burning of San Francisco, the Exposition was bathed in red, with a strikingly realistic demonstration of the burning of the "Tower of Jewels."

Never before was there such flexibility in lighting on so large a scale, making it possible at very small expense and on short notice to introduce modifications in the illuminating effects. This was made feasible by use of the great number of projectors, which on ordinary occasions projected white light, but by the introduction of screens the coloring could be completely changed.

Briefly, the lighting equipment consisted, primarily of direct, masked, concealed and projector lamps, representing an harmonious blending of luminous arc, projector, incandescent electric and gas lamps.

The high current luminous arc lamp was selected for general flood lighting of the facades, lawns, and shrubbery on account of its high efficiency, and relatively low maintenance cost where great quantities of white light was required.

Projectors were used for illuminating the towers and minarets, flags and other features where concentration was necessary.

High efficiency electric incandescent lamps in all ratings from 10 to 1500 watts were employed generally throughout the Exposition, especially where space was limited, warm tones were required and flexibility was of fundamental importance.

High-pressure gas lamps played an important part in street lighting in the Foreign and State sections; as did also low-pressure gas lamps for emergency purposes and gas flambeaux for special effects.

#### TOWER OF JEWELS AND MANUFACTURERS' BUILDING

Illustrating the preservation of depth, or the third dimension in lighting, by a combination of white flood light and color relief light. The scintillator and fireworks were approximately one-third of a mile in the background.

with green, and the towers but every flag in the Exposition took on a

Orange is the prevailing color for the evening of "October 10" the ninth anniversary of the burning of the "Tower of Jewels." The burning of the "Tower of Jewels."

flexibility in lighting on so large a scale was accomplished at a very small expense and on short notice by the use of a great number of projectors, which on the night of the burning of the "Tower of Jewels" were completely changed.

Lighting was installed, primarily of direct, and representing an harmonious and consistent electric and gas

was selected for general illumination on account of its low maintenance cost where great

ing the towers and minarets, and where such attention was necessary.

was in all ratings from 100 to 1000 watts throughout the Exposition.

where space was limited, warm tones were required and the importance.

High-pressure gas lamps were an important part in street lighting in the foreign and State pavilions, and also low-pressure gas lamps for emergency purposes and gas lamps for special effects.

light and color relief light. The acinthis for and firework were approximately one-  
 illuminating the presentation of fever' or the third dimension in lighting, by a combination of white-wood  
 TOWER OF JEWELS AND MANUFACTURERS, BRITISH

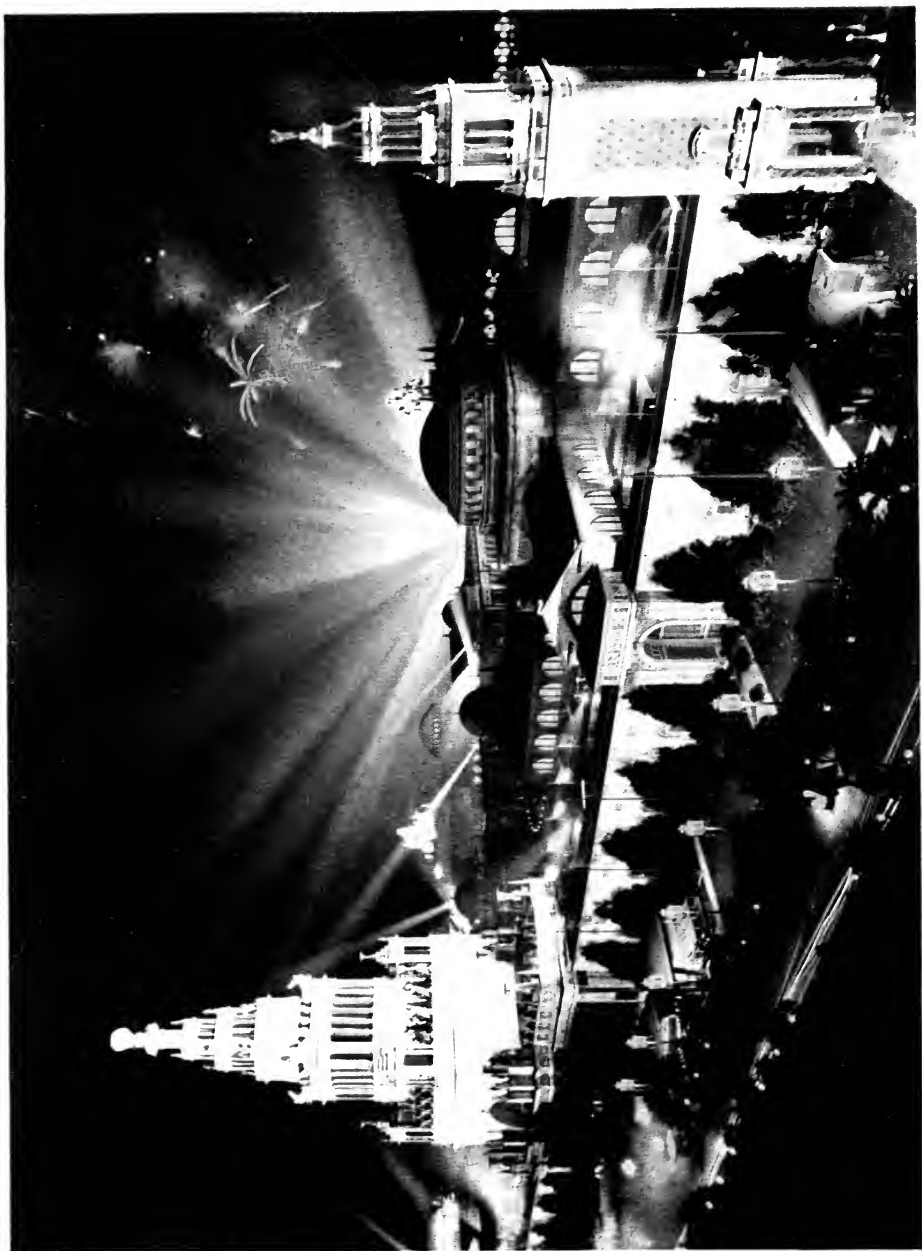





## GENERAL DESCRIPTION OF EXHIBITION

The exhibition was collected in rooms adjacent to the Lecture Hall of the Engineering Building of the University. It covered about 8000 square feet of floor area.

Exhibits were supplied by manufacturers in the lighting field, electric and gas lighting companies, research and development laboratories, the Navy Department and others. It was the intention in designing and collecting these exhibits, to minimize the commercial element and to emphasize the educational value. It was the purpose not only to have apparatus, equipments and illustrations available, but to afford those taking the lecture course every opportunity to familiarize themselves with the material exhibited and with its use and significance. The scope will be indicated by the following partial list of exhibits:

### ILLUMINANTS

- Set of mazda lamps
- Set of miniature mazda lamps
- Historical collection of incandescent electric lamps
- Historical collection of gas "arc" lamps
- Comparison of gas lamps of 1906 with those of 1916
- Collection of metallic flame and flaming arc lamps

### ILLUMINANT ACCESSORIES

- Window lighting reflectors
- Reflectors for interior illumination
- Reflectors for exterior illumination
- Collection showing the development of diffusing glassware
- Decorative lighting glassware
- Fixtures—electric and gas.

### LIGHTING UNITS FOR PARTICULAR PURPOSES

- Artificial daylight equipments
- Mine lamps
- Street lighting units
- Car lighting equipments
- Flood lights and searchlights.

### PHOTOMETRIC APPARATUS

- Bar photometers
- Integrating spheres
- Portable photometers
- Light filters
- Photometer heads
- Electrical instruments
- Physical photometers
- Spectrophotometers
- Flicker photometers
- Photoelectric cell
- Color vision correction screens
- Acuity apparatus.

### OPTICAL APPARATUS

- Spectrum projector
- Comparison spectroscope.

### OPHTHALMOLOGICAL APPARATUS

- Visual acuity devices
- Ophthalmoscopes
- Visual sensitometer
- Pupillary diameter wedges
- Apparatus showing retinal inertia
- Threshold photometer
- Illuminated test cards
- Color test apparatus.

### COLOR APPARATUS

- Spectrophotometer
- Colorimeter
- Color mixture wheel
- Color booths
- Color triangle
- Variable neutral tint scheme.

### MANUFACTURING PROCESSES

- Cabinet illustrating the manufacture of mazda lamps
- Display illustrating characteristics of gas lamps.

### LIGHTING PRACTICE

- Statistics showing importance of illumination in mining operations
- Model of dark room lighting
- Model of street lighting
- Display showing present methods of interior illumination
- Model showing art gallery lighting
- Relation of illumination to safety and output.

### SPECIALTIES

- Exhibit of Bureau of Standards illustrating the work of the Bureau
- Exhibit of Navy Department, illustrating signaling by lighting
- Exhibit of fluorescence due to ultraviolet light
- Diagrams of luminous efficiencies.

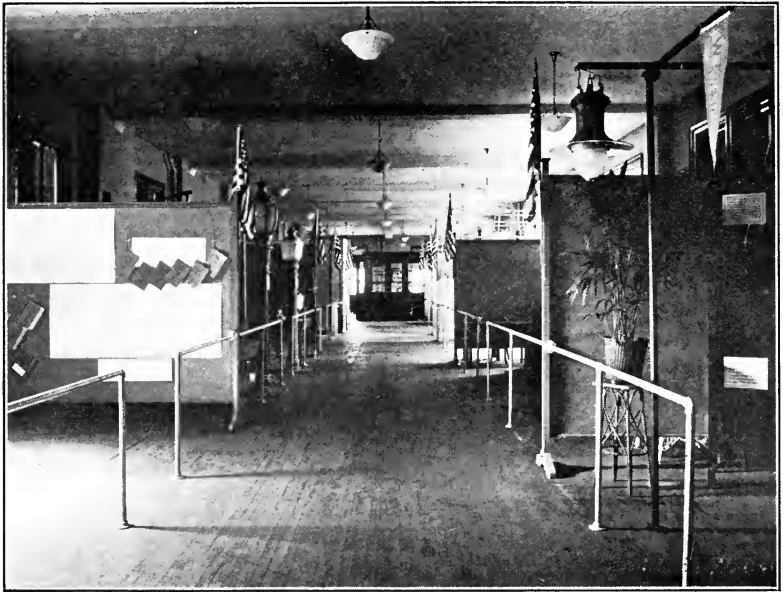

Fig. 1.—View of exhibit room No. 1, looking west.



Fig. 2.—View of exhibit room No. 1, looking east.

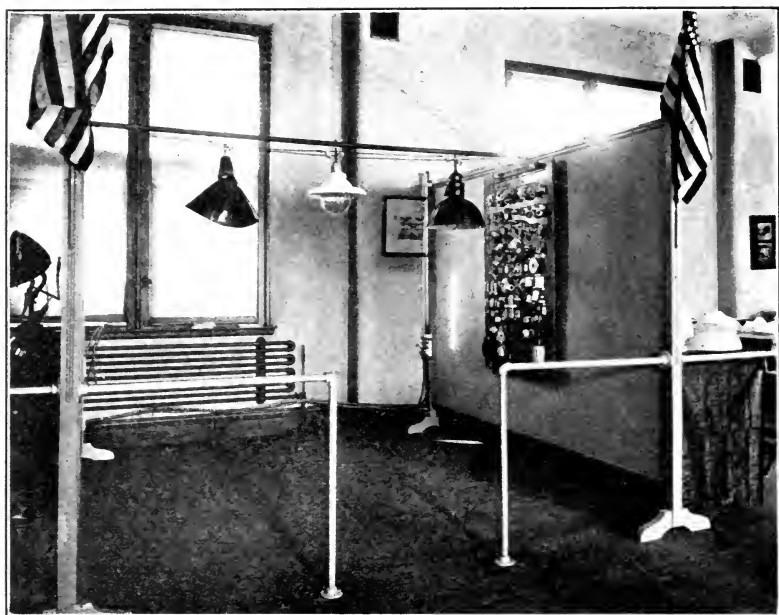

Fig. 3.—Exhibit of Benjamin Electric Company.



Fig. 4.—Exhibit of Bosch & Lomb.

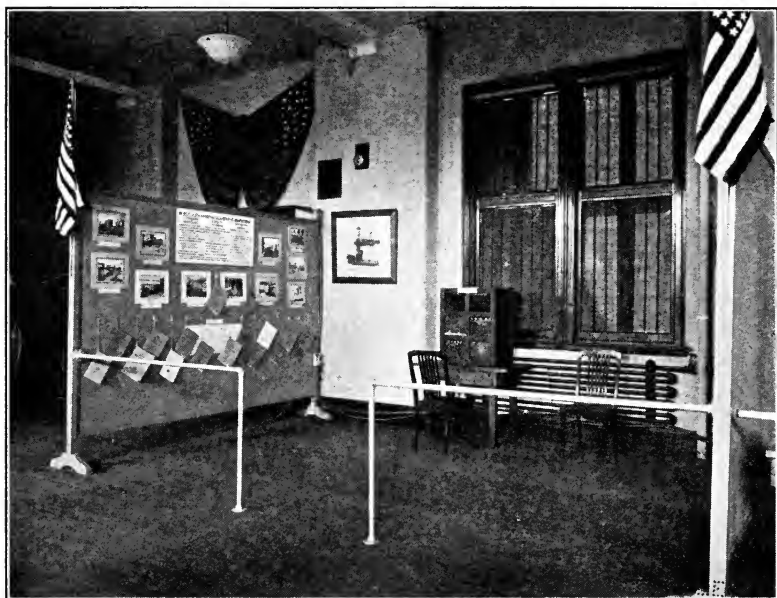

Fig. 5.—Exhibit of Bureau of Standards.

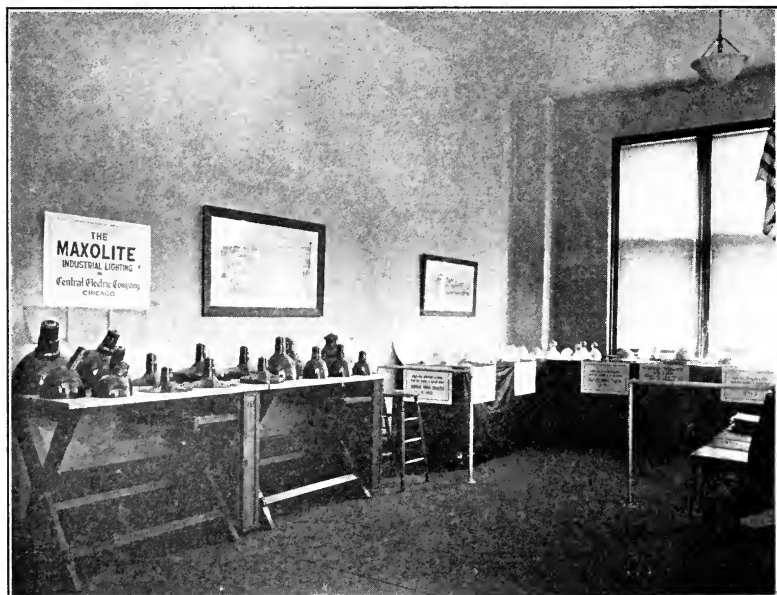

Fig. 6.—Exhibit of Central Electric Company.



Fig. 7.—Research laboratory exhibit of Eastman Kodak Company.



Fig. 8.—Electrical Testing Laboratories, interior lighting model.



Fig. 9.—Electrical Testing Laboratories, interior lighting model.

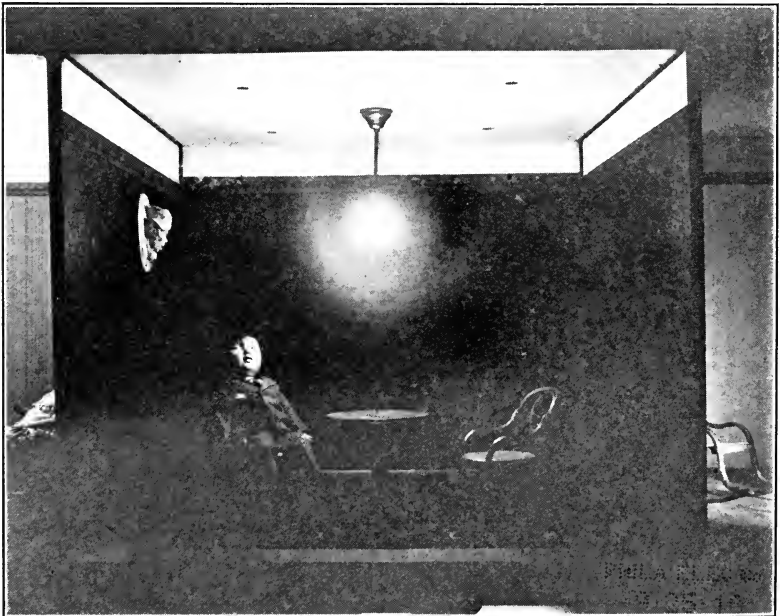

Fig. 10.—Electrical Testing Laboratories, interior lighting model.



Fig. 11.—Electrical Testing Laboratories, interior lighting model.



Fig. 12.—Electrical Testing Laboratories, street lighting model.



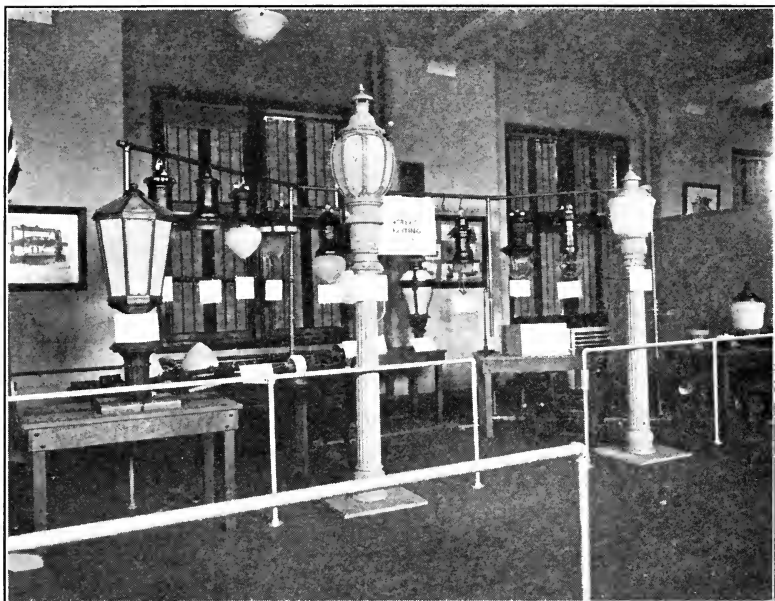

Fig. 13.—Electrical Testing Laboratories, exhibit of street lighting units.

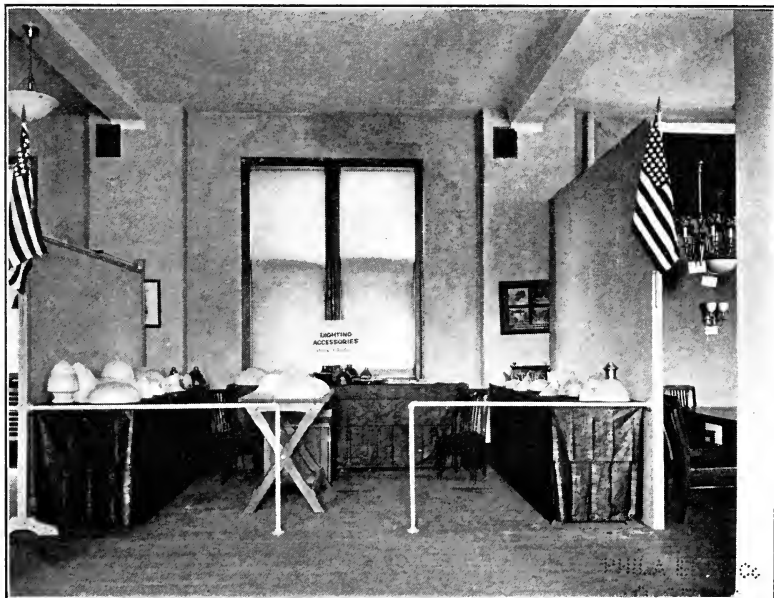

Fig. 14.—Electrical Testing Laboratories, exhibit of lighting accessories.



Fig. 15.—Exhibit of Nela Engineering Department, General Electric Company.



Fig. 16.—Exhibit of Nela Engineering Department, General Electric Company.

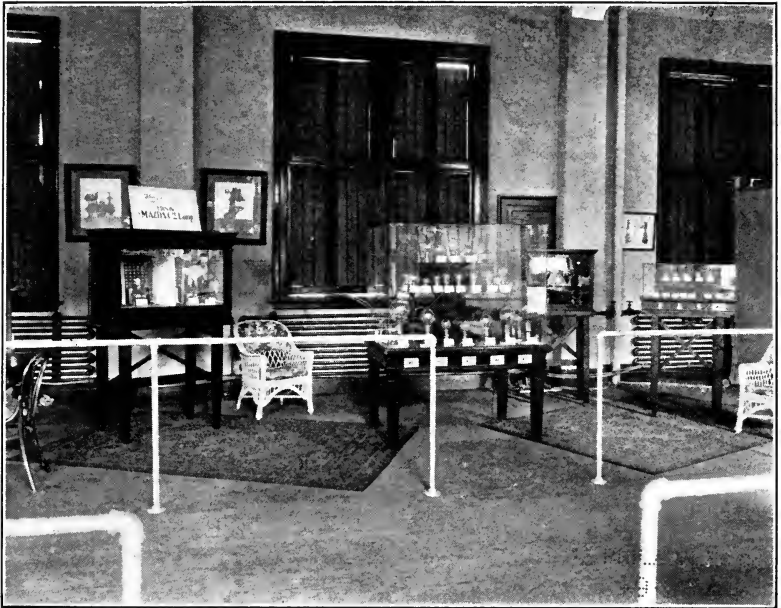

Fig. 17.—Exhibit of Edison Lamp Works, General Electric Company.



Fig. 18.—Exhibit of Consulting Engineering Laboratory, General Electric Company.



Fig. 19.—General Electric flood lighting projectors.

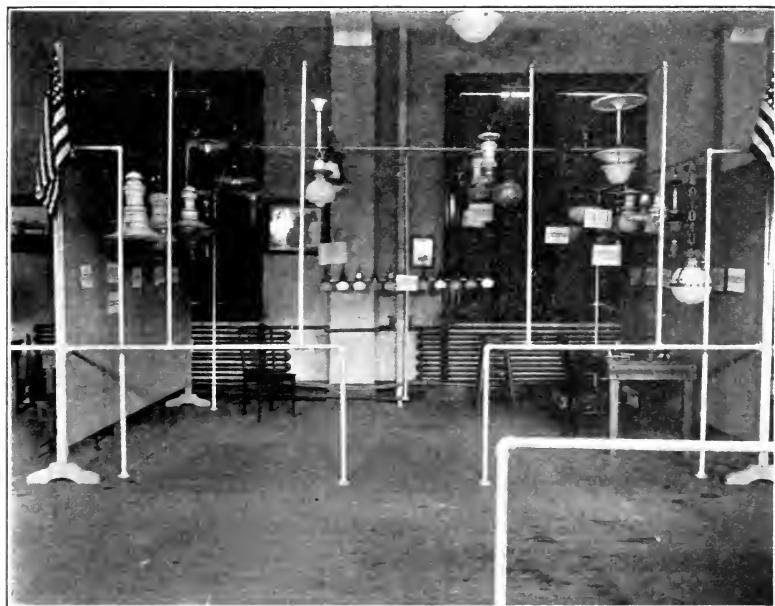

Fig. 20.—Exhibit of General Gas Light Company.



Fig. 21.—Exhibit of Leeds & Northrup Company.



Fig. 22.—Exhibit of Macbeth-Evans Company.

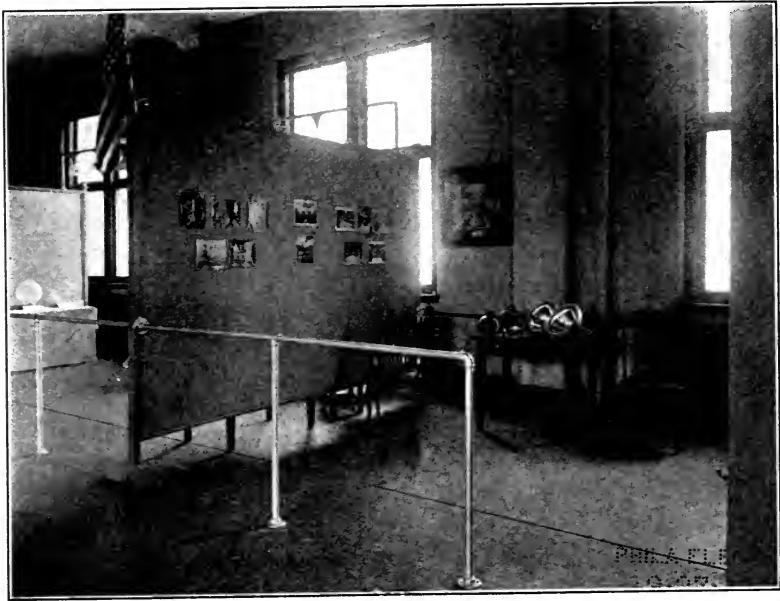

Fig. 23.—Exhibit of National X-ray Reflector Company.

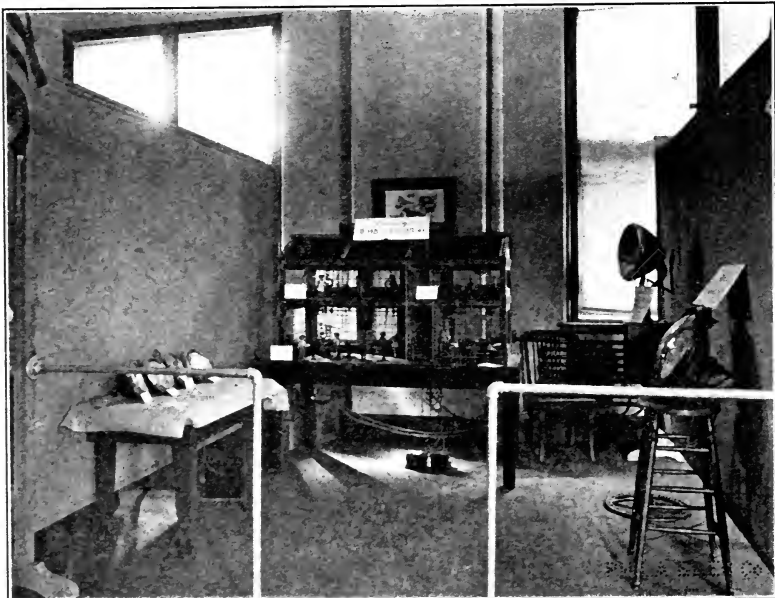

Fig. 24.—Exhibit of the Philadelphia Electric Company.

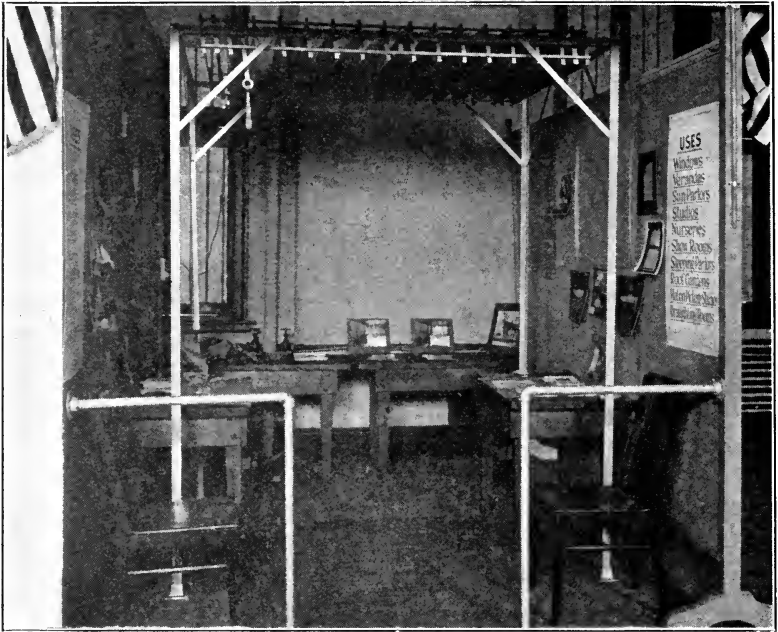

Fig. 25.—Exhibit of Simon Ventilighter Company.

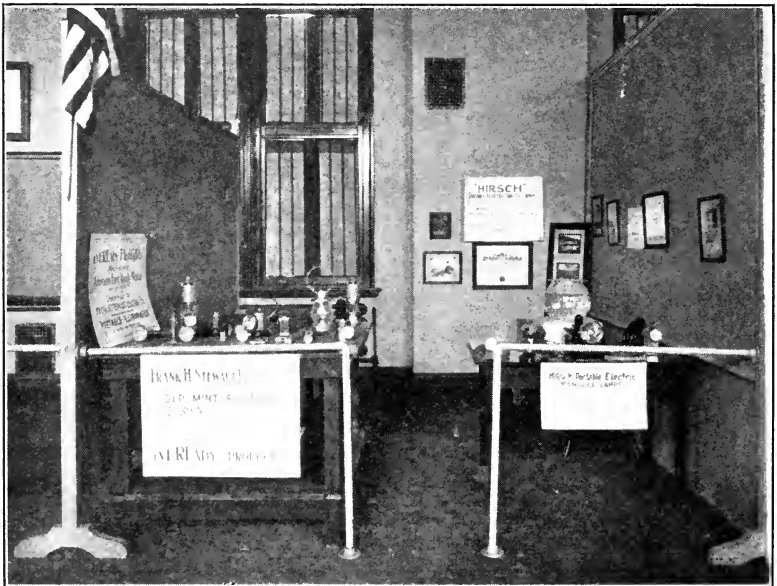

Fig. 26.—Portable lamp exhibit of Frank H. Stewart Electric Company.



Fig. 27.—Light signals exhibited by U. S. Navy.



Fig. 28.—Optical instruments exhibited by Wall & Ochs.



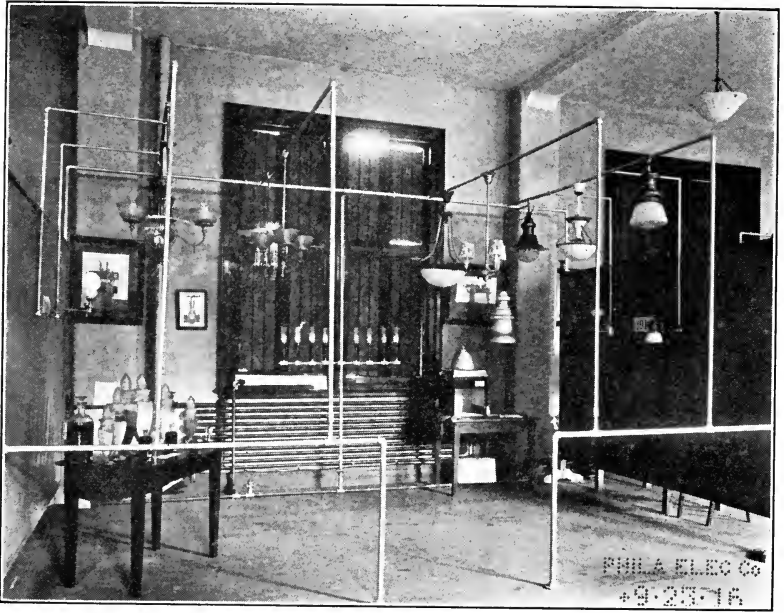

Fig. 29.—Gas lamps exhibit, Welsbach Company.

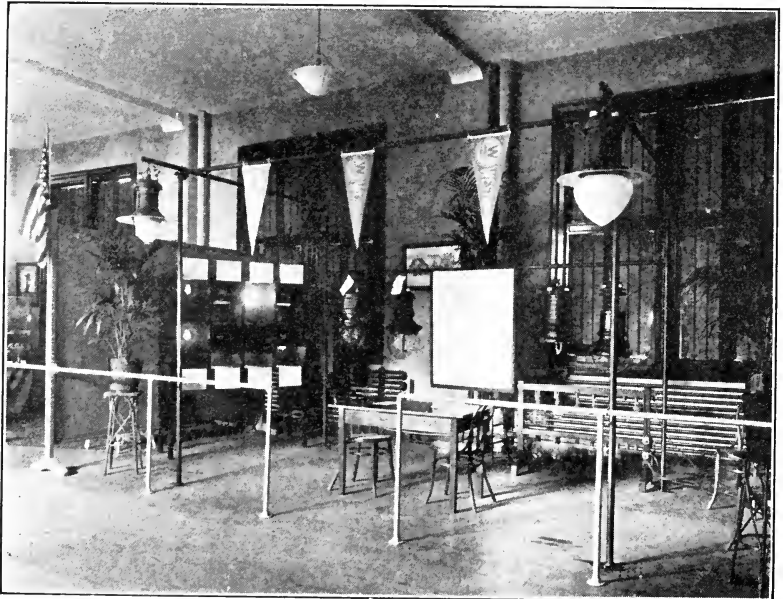

Fig. 30.—Electric lamp exhibit of Westinghouse Company.

# INDEX

- Abbreviations, photometric units, 34
- Absorption-of-light method of calculation, 15
- Accessories, bibliography, 210
- car lighting, 509
  - glass structural characteristics, 186
  - applications, 199
  - light absorption table, 426
  - lighting, 183
  - mirrored, 203
  - prismatic, 200
  - street illumination, 424, 479
- Acetylene flame, brightness, 47
- Arc, carbon, brightness, 47
- intrinsic brilliancy, 216
  - lights, brightness, 47
  - mercury, brightness, 47
- Art museum lighting, 264
- Auditorium illumination, 326
- Automobile headlights, 220
- bibliography, 250
  - regulations various states, 222
- Banks, illumination, 372
- Bar photometer, 109
- Bibliography (various subjects, see name of subject).
- Brightness, artificial sources, 47
- conversion table, 39
  - definition, 31
  - measurements, 123
  - units, 25
  - conversion table, 39
- Brilliancy projection sources, 216
- Burners, gas, characteristics, 168
- Calculations, absorption-of-light method, 15
- illumination, 1
- Candle, brightness, 47
- definition, 30
- Candle-power curve explanation, 4
- definition, 30
  - diagram, flux summation, 12
  - distribution, cylindrical source, 8
  - space representation, 10
  - spherical source, 8
  - per sq. in. method to determine, 27
  - Space distribution, 1
  - various definitions, 33
- Carbon filaments (see filaments).
- lamps (see lamps, also filaments).
- Cars, electric lighting, 495
- axle driven system, 496
  - headend system, 495
  - straight storage system, 496
- gas lighting, 493
- illumination design, 497
- driving, 504
  - fixtures, 510
  - glass ware, 509
  - intensities, 497
  - interurban, 508
  - parlor, 507
  - passenger coaches, 497
  - postal, 507
  - private, 507
  - reflectors, 509
  - sleeping, 505
  - smoking, 506
  - street, 508
- Churches, illumination, 296, 326
- ritualistic illumination, 301
- Color, brightness definition, 270
- in lighting, 267
  - lighting media, 287
  - measurements, 271
  - mixture applications, 291
  - photometry, 271
  - saturation, 269
  - science practice, 268
  - terminology, 269
- Colorimetry, 272

- Contracts, street illumination, 484
- Cost data, various illumination systems (see name of system).
- Curve characteristic, definition, 33  
performance, definition, 33
- Daylight, artificial, 290  
production, 282  
illumination, 19  
measurements, 124
- Decoration by illumination, 253
- Dining room lighting, 263
- Dirt cause of depreciation, 48  
table, 49
- Distribution circuits failing lighting, 355  
street lighting, 472  
curves, definitions, 33
- Docks, illumination, 528  
bibliography, 533
- Drafting room illumination, 319
- Exposure, definition, 30
- Factories, illumination, bibliography, 361  
cost data, 358  
distribution circuits, 355  
intensities, table, 350  
lamps, available, 343  
maintenance, 357  
requirements, 344  
typical plans, 351  
values for manufacturing spaces, 342  
production, relations to lighting, 337
- Filaments, carbon, brightness, 47  
intrinsic brilliancy, 216  
tungsten, brightness, 47
- Filters, light, 102
- Fixtures, car lighting, 510  
design, 207  
gas lamps, residence lighting, 180
- Flame, acetylene, brightness, 47  
candle, brightness, 47  
intrinsic brilliancy, 216  
kerosene brightness, 47
- Flicker photometer, 100
- Flood lighting, 239  
architectural results, 261  
bibliography, 251  
calculations, 92
- Flux, luminous, definition, 29  
summation, candle-power diagram, 12  
graphical construction, 14
- Freight yards illumination, 514
- Gas burners, characteristics, 168  
lamps (see lamps).  
fixtures (see fixtures).  
lighting, cars (see car lighting).  
mantles (see mantles).
- Gasolene lamps (see lamps).
- Glare avoidance, 57  
characteristics headlights, 224  
definition, 55  
elimination, 65  
street illumination, 90, 448, 478
- Glass accessories (see also accessories).  
structural characteristics, 186  
colored, transmission coefficients, 200  
light losses, 195  
transmission coefficients, 193
- Glassware, bibliography, 210  
car lighting, 509  
light losses analysis, 195  
uses, 199
- Globes (see also glassware).  
light absorption, table, 426
- Gymnasium illumination, 322
- Harcourt lamp, characteristics, 105
- Headlighting, bibliography, 250
- Headlights, automobile, 220  
glare characteristics, 224  
railway equipment, 229
- Hue, definition, 269
- Ignition, gas lamps, 173
- Illumination, æsthetic effects, 61  
application of color, 289  
architectural aspects, 253  
artistic, 253  
aspects, 398

- Illumination, auditorium, 326  
   banks (see banks).  
   calculations, 1  
     absorption-of-light method, 15  
     daylight, 19  
     flood lighting, 92  
     point-by-point, 50  
     zone-flux methods, 51  
   cars (see car lighting).  
   churches, 297, 326  
   colored light, bibliography, 294  
     surfaces, 280  
   daylight (see daylight).  
   decorative, 253  
   definition, 30  
   depreciation due to dirt, 48  
     table, 49  
   design effect of accessories, 42  
     examples, 73  
     location of units, 71  
     process, 64  
     selection of source, 64  
   docks (see docks).  
   effect of ceiling bright, 24  
     on production, 337  
   expositions, 547  
     history, 549  
   exterior, building fronts, 440  
     calculation, 84  
     choice of lamps, 95  
     classification, 81  
     color effects, 96  
     principles, 77  
     public monuments, 91  
     strict classification, 86, 89  
   factory (see factory).  
     classification, 347  
     costs, 340  
     legislation, 341  
     requirements, 344  
     typical plans, 351  
   fixtures (see fixtures).  
   flood lighting, 239  
   fundamental characteristics, 309  
   gas developments, 165  
     fixtures, 180  
   hygiene, 53  
   indoor vs. outdoor, 432  
   industrial establishments, 337
- Illumination, intensities industrial serv-  
   ices table, 350  
   interior design, calculations, 37  
     principles, 37  
   large rooms, 329  
   library, 323  
   measurements, 116, 122  
     compensated test plates, 112  
   nomenclature, 29  
   office (see office).  
   outside works, 513  
   pageants, 547  
   physical aspects, 397  
   psychological aspects, 396  
   public monuments, 91  
   quantity for eye efficiency, 59  
   railway cars (see cars).  
   residences (see residences).  
   schools, 311  
   static tester, 121  
   store (see store).  
   street (see streets).  
   sunlight, 46  
   theaters, 330  
   units, 1, 29  
   values, manufacturing spaces, 342  
     street lighting, 89  
   various classes of service, 61  
   window (see window).  
   yards (see yards).
- Illuminometer, Macbeth, 116  
 Intensities illumination, various ser-  
   vices (see name of service).  
 Intensity, luminous, definition, 30
- Kerosene, flame, brilliancy, 47
- Lambert, definition, 25, 31  
 Lamp, definition, 32  
 Lamps, accessories, definition, 34  
   acetylene, efficiency, 41  
   alcohol, efficiency, 41  
   arc development, 146  
     enclosed carbon—engineering  
       date, 154  
     flame engineering data, 154  
     illumination characteristics, 149  
     luminous, 154  
   bibliography, 162

- Lamps, carbon (see filaments).  
 care, 160  
 comparison, definition, 32  
 electric classification, 132  
   developments, 131  
   factory lighting, 343  
   filament, development, 133  
   gas, filled, 134  
   incandescent developments, 133  
     operation, 136  
   Mazda, engineering data, 138  
     street lighting data, 139  
     train lighting data, 138  
   miniature developments, 143  
   specific output, units, 34  
 factory illumination, 343  
 freight yard illumination, 525  
 gas, distant control, 176  
   efficiency, 168  
   electro-magnetic values, 178  
   fixtures, 180  
   ignition, 173  
   photography, 182  
   pilot consumption, 176  
   special application, 181  
 gasoline efficiency, 41  
 Harcourt characteristics, 105  
 kerosene, efficiency, 41  
 Moore carbon dioxide develop-  
   ment, 145  
 old-fashioned simulation, 285  
 selection, 161  
 signal, illumination characteris-  
   tics, 245  
 standard electric, characteristics,  
   106  
 tests, basis, 34  
   definition, 32  
 tube, carbon dioxide, 283  
   development, 145  
   mercury vapor, development,  
     157  
   quartz tube, 158  
   X-ray development, 146  
 tungsten (see filaments).  
   lumens output table, 40
- Libraries, illumination, 307, 323  
 Light, absorption by accessories, 195  
   table, 426
- Light, colored, bibliography, 294  
 distribution calculation, 385  
 filters, 102  
 losses, glassware, 195  
 projection applications, 213  
 sources, brightness, 47  
   brilliancy, 216  
   transmission coefficient, colored  
     glass, 200
- Lighthouses, bibliography, 252  
 projector applications, 242
- Lighting accessories, 183  
 (see illumination).
- Lumen, definition, 30  
 Lux, definition, 30
- Mantles, intrinsic brilliancy, 216  
 gas, brightness, 47  
   physical character, 166
- Mazda lamps (see lamps, electric).
- Mirror, accessories, 203
- Moore lamp (see lamps, tube).
- Motion picture projectors, 246
- Museum, art, lighting, 264
- Office illumination, 363, 366  
 bibliography, 390  
 cost, 368  
 design, 371  
 types, 369
- Photography, gas lamps, 182
- Photometer, bar, 109  
 flicker, 100  
   converted from Zimmer-Brod-  
     hun, 100  
 physical, 99  
 Sharp-Millar, 117  
 tests, definition, 33
- Photometry, abbreviations, 34  
 gas-filled lamps, 125  
 integrating sphere, 110  
   bulky lamps, 112  
   lamps, quick handling, 113  
 standard, 103  
 shades and reflectors, 126  
 liquid filters, 102  
 practice, 99  
 projection apparatus, 129  
 standard lamps, 103

- Pintsch gas car lighting, 494  
 Point source, study, 11  
 Posts for street lamps, 480  
 Projection, general principles, bibliography, 250  
     transparencies, bibliography, 252  
 Projector applications, transparencies, 246  
 Projectors, photometry, 129  
 Quartz tube lamps (see lamps, tube).
- Radiation, luminous, definition, 31  
 Railway headlights, 229  
     bibliography, 250  
 Rating, illuminants, 34  
 Reduction factor, definition, 33  
 Reflection, buildings, 477  
     coefficient, definition, 32, 191  
     table, 193  
     measurements, 127  
     pavements, 449, 477  
     walls, ceilings, floors, 17  
 Reflectors (see also accessories).  
     aluminium, properties, 197  
     bibliography, 210  
     car lighting, 509  
     design, 196  
     effects on illumination design, 42  
     enameled properties, 198  
     gas, 184  
     glass manufacture, 189  
     light absorption table, 426  
     losses, analysis, 195  
     projection, 214  
     metal, 184  
     manufacture, 188  
     optical properties, 191  
     parabolic characteristics, 217  
     photometric properties, 197  
     reflection coefficients, 193  
     uses, 185  
     utilization factors, table, 52-56  
 Residences, basement illumination, 412  
     bath room illumination, 411  
     bedroom illumination, 411  
     den illumination, 409  
     dining room illumination, 405  
     hall illumination, 410  
     Residences, illumination, 395  
     artistic aspects, 398  
     gas lamp fixtures, 180  
     physical aspects, 396  
     psychological aspects, 396  
     practical applications, 400  
     kitchen illumination, 409  
     library illumination, 407  
     living room illumination, 402  
     music room illumination, 408  
     porches illumination, 412  
     sunparlor illumination, 409
- Schoolrooms, illumination values, 315  
 Schools, illumination, 307, 311  
 Searchlight, equipments, 235  
 Searchlighting, bibliography, 251  
 Shade, definition, 271  
 Shadows, effects on eye, 58  
 Sharp-Millar photometer, 117  
 Shop room, illumination, 319  
 Signal lamps (see lamps).  
     lights, bibliography, 252  
 Signaling, projector applications, 245  
 Signs, electric, effect on community, 546  
     engineering features, 542  
     industry, 544  
     modern types, 536  
     ordinances, 545  
     lighting, 535  
 Sky, brightness, 46  
 Sky-light, artificial, 289  
     glass, light losses, analysis, 195  
     illumination calculations, 21  
 Spectrophotometry, 272  
 Standard, luminous, primary definition, 32  
     luminous, representative definition, 32  
     reference, definition, 32  
     working definition, 32  
 Stations, freight illumination, 527  
     passenger illumination, 531  
 Steradian, definition, 3  
 Stores, direct lighting equipment, 378  
     gas lighting, 380  
     illumination, 363, 373  
     systems, 377

- Stores, show case lighting, 381  
 window lighting, 382
- Street illumination accessories, 424, 479  
 arc lamps, 467  
 bibliography, 459  
 calculations, 428  
 city requirements, 461  
 contracts practice, 486  
 requirements, 485  
 contractual relations, 484  
 cost reduction effect, 491  
 design, 435, 456, 469, 474  
 effect of pavements, 477  
 electric circuits, 472  
 flux on street, 430  
 glare reduction, 90, 448, 478  
 graded results, 482  
 history, 415  
 illuminants, characteristics, 423, 465  
 recent history, 420  
 incandescent lamps, 468  
 lamp locations, 451  
 large units, 466  
 measure of service, 488  
 pavement reflection, 449  
 posts and mountings, 480  
 public policy, 492  
 purposes, 415  
 scope, 417  
 small units, 467  
 state control, 490  
 street classification, 465  
 tests, 453  
 typical intensities, 438  
 values of illumination, 89  
 variability along street, 441
- Street illumination, visual characteristics, 430
- Streets, classification for illumination, 465
- Sunlight, artificial, 289
- Tint, definition, 271
- Theaters, illumination, 330
- Transmission coefficients (see name of material).  
 light through glass, 192  
 measurements, 127
- Tungsten lamps (see filaments, also lamps).
- Units illumination, 1  
 photometric, table, 34
- Utilization factor, definition, 18  
 factors, table, 52-56
- Valves, electro magnetic, 178
- Vehicle head lights, 220
- Visibility, definition, 30
- Vision phenomena, 463
- Window illumination, 363, 382  
 bibliography, 390  
 light distribution, calculation, 385  
 source, calculation, 21
- X-ray lamps (see lamps).
- Yard illumination, bibliography, 533  
 freight classification illumination, 521  
 illuminants, 525  
 illumination, 514







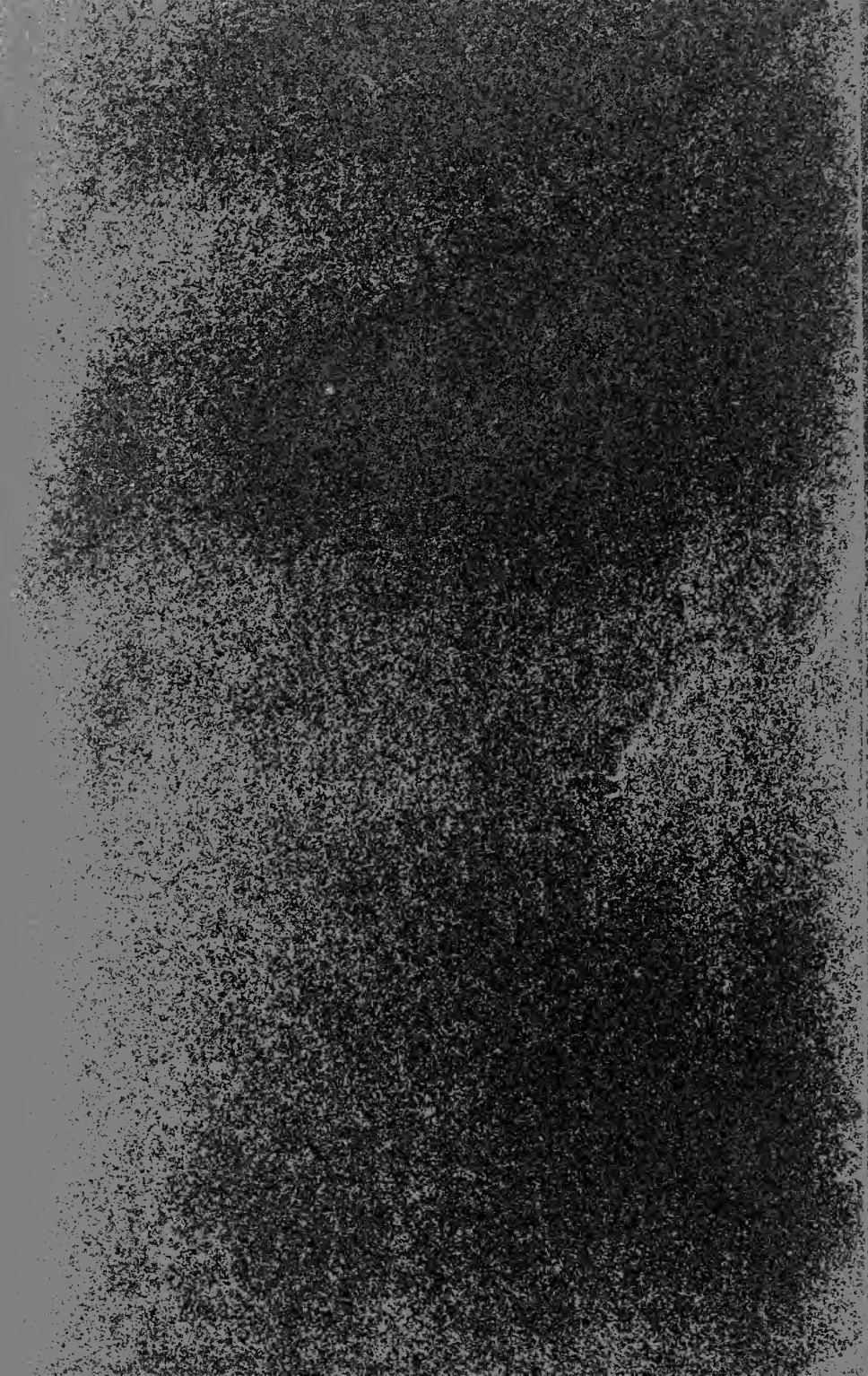



TC 88707

GENERAL LIBRARY - U.C. BERKELEY



8000330814

TH  
773  
11  
11

THE UNIVERSITY OF CALIFORNIA LIBRARY

