

EX LIBRIS



ILLUMINATION



MACMILLAN AND CO., LIMITED
LONDON • BOMBAY • CALCUTTA
MELBOURNE

THE MACMILLAN COMPANY
NEW YORK • BOSTON • CHICAGO
ATLANTA • SAN FRANCISCO

THE MACMILLAN CO. OF CANADA, LTD.
TORONTO

AGOSTA



PIERRE BOUGUER

B. 1698. D. 1758

ILLUMINATION

ITS DISTRIBUTION AND
MEASUREMENT

BY

ALEXANDER PELHAM TROTTER



MACMILLAN AND CO., LIMITED
ST. MARTIN'S STREET, LONDON

1911

TH 7703
77

TO VINDI
ALBERTA CO

TO
THE MEMORY
OF
PIERRE BOUGUER
THE FATHER OF PHOTOMETRY

241503

PREFACE

THIS book is intended to advance the subject of illuminating engineering or the art of directing and adapting light. It is divided into three parts. The first deals with the primary and the derived units of light, the theory of the distribution of illumination and the application of that theory to the spacing and the height of lamps. The second part describes instruments and methods employed for measuring light and illumination. The last part gives a few practical examples of the measurement of illumination.

“The art of illumination,” wrote Count Rumford in the year 1789, “although it is undoubtedly one of the most useful that has been invented by man, and contributes perhaps more than any other to his comfort and convenience in all countries and in every class of society, has not even been considered as an art; for the technical terms have not been invented which are indispensably necessary in order to render it possible to treat of it in a clear and satisfactory manner.”

One hundred and three years later, on May 10, 1892, a paper, of which the present volume is an expansion, was read before the Institution of Civil Engineers, was awarded a Telford Medal and a Telford Premium, and was published in volume cx. of the Proceedings of the Institution. The subject still continued to attract little attention, and after sixteen years, at the invitation of Mr. Leon Gaster, and with the permission of the Council of the Institution of Civil Engineers, the Paper was rewritten and appeared in *The Illuminating Engineer*.

It has now been revised and extended and is offered not as a complete treatise, but as a record of the work of others and of my own investigations in evening hours, scant holidays, and spare moments.

It would not be possible within the compass of a single volume to deal comprehensively with the art of illumination. The scope of this book is limited to the principles and methods of distribution and measurement of illumination. The subject of photometry proper has been made subordinate, descriptions of systems of lighting and various kinds of lamps and appliances have been excluded, and the temptation to touch on innumerable side issues of scientific interest has been resisted. The theory of the distribution of illumination is excellently adapted for mathematical treatment, but I have preferred to deal with it in the manner in which it appeals to me, believing that for practical engineers the use of graphic methods will be more useful than equations and formulae. The calculated curves and diagrams have been drawn on a large scale and most of them are accurate within the thickness of the line.

The original works of nearly all the quoted writers have been consulted, not only for the purpose of verifying references and correcting them when erroneous, but for presenting in their own words and with their own illustrations some idea of the work of the old masters of photometry.

I have to express my thanks to Professor Silvanus Thompson for the loan of valuable old books, and to Professor J. T. Morris for reading most of the manuscript, and for his useful criticisms and suggestions, to Mr. J. Rennie for help with some of the computations, and to Mr. P. Webberley for assistance in revising proofs.

A. P. TROTTER.

CONTENTS

CHAPTER I

UNITS AND STANDARDS OF CANDLE-POWER

Introductory, 1. Intensity or Candle-power, 2. Units and Standards, 3. The Carcel, 3. The British Candle, 4. The German Candle, 4. The Harcourt or Pentane Lamp, 4. The Hefner or Amyl-acetate Lamp, 5. The Violle, 7. The Bougie-décimale, 8. The Relative Values of the Standards, 8. Corrections for Flame Standards, 9. The Advantages of the Pentane and the Hefner, 11. The Arc Standard, 12. Radiation Standards, 13. Glow-lamp Sub-standards, 13.

CHAPTER II

ILLUMINATION AND DERIVED UNITS

Illumination, 15. The Foot-candle, 15. The Lux, 17. The Law of Inverse Squares, 17. The Cosine Law, 19. Mean Spherical Candle-power, 20. Flux of Light or Total Light, 21. Brightness or Intrinsic Brilliancy, 23. Quantity of Light and Quantity of Illumination, 23. Diffused Reflection, 24.

CHAPTER III

THE DISTRIBUTION OF ILLUMINATION

Distribution of Illumination on a Plane, 27. Theoretical Examples of Distribution, 29. Distribution from an Arc-lamp, 32. Distribution from a Vertical Filament, 34. General Cases of Distribution, 35. Distribution by Lamps at Varying Heights, 37. Relation between Height and Spacing of Lamps, 38. The Spacing of Street Lamps, 40.

ILLUMINATION

CHAPTER IV

DISTRIBUTION OF ILLUMINATION OVER A PLANE

The Construction of Contours, 45. Contours or Iso-lux Curves, 47. Bases of Comparison of Cases of Illumination, 52. Characteristic Curves, 58.

CHAPTER V

PHOTOMETERS

Photometry, 65. Discrimination Photometers, 70. Photometers, 74. The Bouguer Photometer, 74. The Rumford Photometer, 77. The Foucault Photometer, 80. The Harcourt or Gas Referees' Photometer, 81. The Bunsen Photometer, 83. The Ritchie Photometers, 87. The Angle of the Ritchie Wedge, 91. Angle Errors, 95. The Conroy Photometer, 97. The Thompson-Starling Photometer, 98. The Lummer-Brodhun Photometer, 99. The Wild Mirror Photometer, 102. The Perforated Screen Photometer, 102. The Slot or Limit-Gauge Photometer, 106. The Grid Photometer, 109. The Joly Photometer, 110.

CHAPTER VI

ACCESSORY APPARATUS

Photometer Scales, 112. The Compensation Method, 115. The Illumination Gradient, 120. The Limitation of the Law of Inverse Squares, 121. The Moving Mirror Method, 123. The Construction of the Bar and Scales, 125. Rotating Sectors, 127. Milne Paddle, 130. The Lampholder, 130. Observation Recorder, 132. Screens and Stray Light, 134. Dead Black Paints, 138. Control of Electric Glow-lamp Sub-standards, 138.

CHAPTER VII

DISTRIBUTION OF LIGHT FROM A SOURCE

Mean Horizontal and Spherical Candle-power, 141. The Horizontal Distribution of Light from Glow-lamps, 141. Mean Horizontal Candle-power, 143. The Distribution of Light from Glow-lamps and other Lamps, 145. The Distribution of Light from Arc-lamps, 146. Mean Spherical Candle-power, 149. Calculation of Mean Spherical Candle-power, and Rousseau's Diagram, 150. Russell's Construction, 151. Measurement of Mean Spherical Candle-power, 153. Ulbricht's Globe, 157.

CHAPTER VIII

THE PHOTOMETRY OF COLOURED LIGHTS

Introductory, 161. Abney's Method, 164. The Purkinje Effect, 166. Colour Vision, 168. Crova's Method, 170. Coloured Screens, 174. The Flicker Photometer, 174. The Speed of Flicker photometers, 179. Selective Emissivity, 181.

CHAPTER IX

ERRORS

Accuracies, Errors, and Mistakes, 183. The Calculation of Errors, 185. Familiarity with the Photometer, 189. General Experience with Photometry, 190. Physical Conditions of the Observer, 190. Speed of Working, 192. Colour Difference, 193. Steadiness of the Light, 193. The Illumination on the Photometer, 194. Instrumental Errors, 196. Stray Light, 196. Precision, 197.

CHAPTER X

THE MEASUREMENT OF ILLUMINATION

Illumination Photometry, 199. The Preece Illumination Photometer, 200. The Preece and Trotter Illumination Photometer, 202. Millar's Criticisms on Illumination Photometers, 206. The Trotter Illumination Photometer, 208. Low Readings and Zero, 209. Adjustment of the Lamp, 210. The Nalder-Trotter Illumination Photometer, 210. Later Pattern Trotter Illumination Photometer, 211. Everett-Edgcumbe's Pattern of Trotter Illumination Photometer, 212. Direction of View, 214. Adjustment of the Lamp, 215. The Screens, 216. Angle Errors, 217. Error due to Glaze, 218. Measurement of Angle Errors, 218. Scale of Angles of Incidence, 223. Measurement of Candle-power, 224. The Battery, Switch, and Contacts, 226. Height of the Photometer, 227. Direction of the Test-plate, 229. The Use of Coloured Screens, 232. The Harrison Photometer, 234. The Weber Photometer, 236. The Sharp and Millar Photometer, 239. The Wingen-Krüß Photometer, 241. The Martens Photometer, 242. Iris Diaphragm Photometers, 243. Brightness Photometers, 244. The Dow and Mackinney Lumeter, 244. The Everett-Edgcumbe Luxometer, 245. The Trezise Photometer, 246. Photometry of the Daylight Illumination of the Interior of Buildings, 246.

CHAPTER XI

PRACTICAL EXAMPLES OF MEASUREMENTS OF ILLUMINATION

Wimbledon, 250. London, 250. South Kensington Museum, 251. Charing Cross and Cannon Street Stations, 253. City of London, 254. Whitehall, 257. Modern Practice, 260. Ordinary Streets, Theatre Lighting, etc., 261. Characteristic Curves, 262.

CHAPTER XII

Dioptric Distribution and Diffusion of Light, 263.

APPENDIX

Table I. Round Numbers of $\cos^3\theta$, 275. Table II. $\cos^3\theta$. Round Numbers of θ , 276. Table III. Powers of $\cos\theta$. Round Numbers of $\tan\theta$, 277. Table IV. Foot-candles, 278. Table V. Graduation of Ratio Scale, 279. Refraction Goniometer, 280.

	PAGE
BIBLIOGRAPHY	283
INDEX	289

ILLUSTRATIONS

FIG.	PAGE
Portrait of Pierre Bouguer, by Perroneau. Engraved by Miger, Bib. Nat. de France	<i>Frontispiece</i>
1. The Vernon Harcourt Pentane 10-candle Lamp	5
2. The Hefner Amyl-Acetate Lamp	6
3. Law of Inverse Squares	18
4. Slide-rule set for Calculating Illumination	18
5. " " "	19
6. Cosine Law	19
7. " " "	20
8. Cube of Cosines	27
9. Curve of Cosines cubed	28
10. Illumination Curves, Lights at a distance apart equal to their height	30
11. " " " twice their height	31
12. " " " three times their height	31
13. " " " six times their height	32
14. Illumination Curve of Arc-lamp, Candle-power, and $\cos^4\theta$ Curve	33
15. Candle-power Curve of a Vertical Filament	34
16. Illumination Curve of a Vertical Filament	34
17. Curves of $\cos\theta$, $\cos^2\theta$, $\cos^3\theta$, $\cos^4\theta$, and $\cos^2\theta \sin\theta$	36
18. Curve of Variation of Illumination at a point, for Lamp at varying height	37
19. Illumination Curves for Horizontal Plane, Lamp at varying heights	38
20. Illumination Curves for Plane facing a Lamp at varying heights	39
21. Locus of Lamp giving constant illumination at a point on a plane	42
22. Locus used in connection with spacing and height of Lamps	43
23, 24. Locus for Vertical Filament giving Constant Illumination	43, 44
25. Construction of Contours by Intersecting Circles	46
26. " " Trammels	46
27. Contours for two Lights at a distance apart equal to three times their height	47
28. " " " four times their height	48
29. Contours for three Lights, derived from Fig. 28.	48
30. Contours for three Lights at a distance apart equal to one and a half times their height	49
31. Illumination Curve, section of Fig. 30	49
32. Contours for three Arc Lights, distance apart, one and a half times their height	50

FIG.	PAGE
33. Illumination Curve, section of Fig. 32	50
34. Contours for three Arc Lights; distance apart, three times their height	51
35. Illumination Curve, section of Fig. 34	51
36. Double Curve of cosines cubed	54
37. Archimedes' Theorem of Surface of Cylinder and of Sphere	55
38. " " " " " "	55
39. " " " " " "	55
40. Curve of Flux, or Solid Contents	56
41. Flux or Solid Content over given radius	56
42. Graphical Construction to find Flux	57
43. Characteristic Curve	59
44. " " " " " "	60
45. Construction for Characteristic Curve	60
46. Ordinates of Characteristic Curve	61
47. Characteristic Curves derived from Figs. 10, 11, and 12	62
48. Contours derived from Fig. 29	62
49. Illumination Curve along middle of Fig. 48	63
50. Illumination Curve for a line passing through the lamps in Fig. 48	63
51. Characteristic Curve for Fig. 48	63
52. Curves of Maxima and Minima, or Diversity Factor Curves for cases in Figs. 10, 11, 12, and 13	64
53. Houston and Kennelly's Photometer	71
54. Fleming's Discrimination Photometer	72
55. Bouguer's Photometer	76
56. Rumford's Photometer	79
57. Foucault's Photometer	81
58. Photoped of Vernon Harcourt or Gas Referees' Photometer	82
59. Bunsen's Photometer, front view	85
60. Bunsen's Photometer, plan	85
61. Ritchie's Photometer	88
62. " " " " " "	90
63. Mirrors of Ritchie's Photometer	90
64. " " " " " "	90
65. Angles of the Ritchie Wedge	92
66. " " " " " "	92
67. " " " " " "	93
68. Relation of Brightness to Angle for different Screens	93
69. Angle Errors	96
70. Conroy's Photometer, plan and elevations	98
71. " " " " " " perspective view	98
72. Thompson and Starling's Photometer	98
73. Lummer-Brodhun Photometer	100
74. " " " " " " Contrast Field	101
75. Perforated Screen Photometer	104
76. " " " " " " plan	104

ILLUSTRATIONS

XV

FIG.	PAGE
77. Star Hole	105
78. Slot Photometer—arrangement of Lamps	107
79. „ „ Field	107
80. „ „ Plan	108
81. Grid Photometer	109
82. Joly's Photometer	110
83. Photometer Scales	113
84. Slide Rule set for calculating Photometer Scale	114
85. The Ratio Scale	115
86. Double Scale of Squares	116
87. Photometer Head and Working Lamp coupled together	117
88. Illumination Gradient	120
89. Light from a finite straight Filament	121
90. Deviation from the Law of Inverse Squares	123
91. The Moving Mirror Method	124
92. Everett-Edgcombe Bar and Carriage	126
93. The Abney Sectors	130
94. Lamp mounted on Carriage	131
95. Observation Recorder	132
96. Record	133
97. Screens	136
98. Electrical Arrangements for use with Sub-standard Lamps	139
99. Reflection from Bulb	142
100 A, B. Candle-power of Glow-lamp at various horizontal angles, and polar curve	142-143
101. Wild's Mirrors for Mean Horizontal Candle-power	144
102. Auxiliary Mirrors	145
103. „ Mirror	145
104. Candle-power of Glow-lamp at various angles with the horizon	146
105. „ „ Arc-lamps	147
106. Mirror and Lens for projecting image of arc	147
107. Images of Carbons of Arc-lamp viewed at different angles	148
108. Candle-power and Visible Area of Crater at different angles	148
109. Relation of Area of Crater to Candle-power	149
110. Rousseau's Diagram	150
111. Candle-power of "Oriflamme" Arc	151
112. Russell's Construction of Rousseau's Diagram	152
113. Rousseau Diagram for Crompton-Blondel Arc	153
114. Blondel's Annular Ellipsoidal Lumenmeter	154
115. Blondel's Diffusing Cone Lumenmeter	154
116. Dyke's Arrangement of Mirrors for Mean Spherical Candle-power	156
117. Wild's „ „ „ „	157
118. Theory of Ulbricht's Globe	158
119. „ „ „ „	158
120. The Ulbricht Globe	160

FIG.	PAGE
121. Crova's Diagram of Luminosities	171
122. Abney and Festing's Diagram of Luminosities	172
123. Relation of Luminosity of various Rays with Intensity	172
124. Whitman's First Flicker Photometer	175
125. Whitman's Diagram of his Flicker Photometer	175
126. Whitman's Disc for Flicker Photometer	176
127. Views of Simmance-Abady Disc for Flicker Photometer	176
128. Relation of Illumination to frequency at which Flicker disappears. Kennelly and Whiting	178
129. Relation of Illumination to frequency at which Flicker disappears. Morris and Trotter	180
130. Relation of Illumination to frequency at which Flicker disappears. Dow	181
131. Ambiguous and Clear View of Scale	184
132. Relation of Illumination to Precision	194
133. Broca's Disc	195
134. Preece's Illumination Photometer	201
135. Preece and Trotter Illumination Photometer	203
136. Early Pattern Trotter Illumination Photometer	206
137. Second Pattern „ „ „	208
138. Levers of „ „ „	209
139. Scale of „ „ „	209
140. Later Pattern of „ „ „	212
141. Everett-Edgcombe's Pattern of Trotter Illumination Photometer	213
142. Scale of „ „ „ „ „	213
143. Movable Screen „ „ „ „ „	214
144. External View „ „ „ „ „	215
145. Worst Position for Error due to reflected light	219
146. Best Position for „ „ „	219
147. Polar Diagram of Errors due to glaze	220
148. „ „ „	220
149. „ „ „	221
150. Cartesian Diagram „ „	222
151. „ „ „	223
152. View of Illumination Photometer showing Graduated Quadrant	223
153. Dimensions used in Street Work	225
154. Height of Illumination Photometer, calculated	228
155. „ „ „ practical example	229
156. Illumination on Vertical Planes	232
157. The Harrison Photometer, outside view	235
158. „ „ „ end view of interior	235
159. „ „ „ side view	236
160. The Weber Photometer	237
161. „ „ „ section	238
162. Sharp and Millar's Photometer	239
163. „ „ „	239

ILLUSTRATIONS

xvii

FIG.	PAGE
164. Angle Errors of Sharp and Millar's Photometer	241
165. " " " " " " " "	241
166. Wingen-Krüß Photometer	242
167. Martens Photometer	243
168. Dow and Mackinney's Lumeter	245
169. Everett-Edgcombe's Luxometer	246
170. Daylight Attachment for Photometer	248
171. Illumination Curve, Wimbleton, 1884	250
172. " " in Cannon Street Station	253
173-177. " " in City of London	254-255
178. Contours in Queen Victoria Street	256
179. Illumination Curve in Queen Victoria Street	256
180. " " " " " " "	257
181. " " of Arc-lamps. Preece	257
182. Contours in Whitehall	258
183-187. Illumination Curves, Whitehall	258-260
187A. " " Great George Street, Westminster	261
187B. Characteristic Curves	262
188. Diagram, Double \cos^3 curve	264
189. Diagram, Equal Annuli	265
190. Reflector for Uniform Distribution	265
191. Profile of Distributing Prisms	266
192. Profiles of Dioptric Pane	267
193. Enlarged Profiles of Distributing Prisms	267
194. Dioptric Lantern	267
195. Diffusing Fluting	268
196. Dioptric Shades	268
197. Plan of Street for Dioptric Distribution	269
198. Profile of Compound Diffusing Fluting	269
199. Early Illumination Curve, Reflectors	270
200. " " " " " " "	271
201. Illumination Curve, Dioptric Distributing Shade	271
202. One of Fredureau's Prismatic Shades	272
203. Holophane Diffusing Fluting	272
204. Holophane Compound Prism	272
205. Korting and Mathieson's Dioptric Shade	273
206. Polar Curve, showing effect of Korting and Mathieson's Dioptric Shade	273

APPENDIX

1. Refraction Goniometer	280
2. Family of Curves, Angles of Prisms	281
3. Diagram of Path of Ray through Prism	281
4. Refraction Diagram	282

CHAPTER I

UNITS AND STANDARDS OF CANDLE-POWER

Introductory.—Light being an expenditure of energy, it is accurate to speak of “candle-power,” since it is the measure of the rate of expenditure of energy. The art of illumination is therefore, in a very definite sense, a matter which comes within the province of civil engineers, since it is the art of directing this power for the use and convenience of man. The study of light, its nature and laws, belongs to the science of optics, but we may look to optical treatises in vain for any useful information on the present subject. Illumination, if alluded to at all, is passed over in a few lines, and it has remained for engineers to study and to work out the subject for themselves. Fortunately the geometrical laws of the distribution of illumination are very simple, and those of photometry are as easy. The physiological side of the question presents some puzzles, and these should receive attention from psychologists who are conversant with the practical difficulties of subjective investigations. Notwithstanding the attention which has been given to the matter during the last few years, the specification of a required illumination of a street or of a railway station would perplex most contractors. The time is only now arriving in which a required illumination may be intelligently expressed by a specification.

The vocabularies of the French and English languages are remarkably rich in words connected with light. Such terms as illumination, brilliance, brightness, intensity, and luminosity are generally employed by different writers to express different

ideas, and are often used in a confused and vague way. The terms force, power, work, energy, and efficiency have been used by the general public, and will continue to be used, in a very loose and inexact manner. It has been the business of engineers to attach precise meanings to them for their own purposes, to recognise these as the only proper meanings, and to regard a misuse of one of them as a mark of ignorance of the elements of engineering science.

Light for the present purposes means visible radiation emitted from a flame or incandescent surface, or reflected from a surface. The word "light" is often loosely used instead of intensity of light or quantity of light. In one sense light is no more a physical quantity than dimness or darkness, it is a general term; in another sense it is luminous radiant energy. The particular terms which denote the chief physical quantities are intensity, commonly called candle-power; flux, or spherical candle-power; illumination; brightness, or intrinsic brilliancy; and quantity of light.

One of the difficulties of this subject is that the use of light and illumination is to satisfy the eye, and the eye is a very poor judge of the physical quantities in question. It is well known that even experts cannot make a tolerable estimate of the candle-power of a lamp by merely looking at it when alight. An estimate of the "heft" of a letter, whether it is over or under 4 ounces, the temperature of the air, a length in inches or feet, or the contents of a vessel in pints or gallons can be made by most persons with greater accuracy than a guess at the candle-power of a lamp. Comparative estimates are not much better. It is easy to see that a 12-candle-power lamp gives less light than a 16-candle-power lamp, but it is very difficult to say how much less.

Intensity or Candle-Power.—Candle-power is measured as an intensity in any direction. It is also measured as a flux by the product of a solid angle into the candle-power. At an unofficial congress at Geneva in 1896 the name "pyr" was suggested for a unit of intensity, and Dr. J. A. Fleming* has

* *Journ. Inst. Elec. Eng.* xxxii. 164.

proposed the name "lamp" for a 10-candle standard, on the ground that the candle itself having been abandoned, the name need not be retained. It is unfortunate that the word candle-power has taken such a firm position in technical language, and it is curious that we seldom use the word intensity, and its use by the French in connection with electric current appears to us redundant. If the word candle-power were not so well established, there would be a better chance of agreeing on an international standard of intensity. If a "daniel" had been in extensive use as a unit of electromotive force there would have been more difficulty in introducing the volt.

Units and Standards.—A distinction must be made between an abstract unit of light and an actual standard. It would be convenient, but it is not necessary, that they should be of the same magnitude. The unit of electromotive force is one volt, but the Clark cell, reputed to have an electromotive force of 1.434 volt, was used for many years; and now the Normal Weston cell, having an electromotive force of 1.0184, is the standard. Similarly, the Hefner amyl-acetate lamp, having a candle-power of 0.9, is a very convenient standard, while the one recognised in England is the 10-candle Pentane lamp. It is quite possible that a more satisfactory apparatus of quite another kind may be discovered. If the electric arc standard had been found practicable it would have been about 150 candle-power. Our English expression candle-power confuses the matter by begging the question.

A brief account will be given of the more important standards which have been proposed and used from time to time. Further information may be obtained from the writings of those who have given special attention to the subject.*

The Carcel.—The earliest standard of light was the Carcel lamp, introduced in 1800, and used by Regnault and Dumas for testing gas, and is still employed officially for that purpose in France. It is a colza oil lamp containing a clock-work

* Palaz, *Traité de photométrie industrielle*; J. W. Dibdin, *Practical Photometry*; W. M. Stine, *Photometrical Measurements*; Dr. J. A. Fleming, *Journ. Inst. Elec. Eng.* vol. xxxii.; C. C. Paterson, *Journ. Inst. Elec. Eng.* vol. xxxviii.

pump, and has an Argand burner and glass chimney of certain specified dimensions.*

The value in British candle-power was determined by Sugg in 1870 as 9.6; in 1885 Dibdin made it 9.4; while C. C. Paterson, at the National Physical Laboratory, gave 9.82; and at a photometric meeting held at Zurich in July 1907, this last value was confirmed. The discrepancies may be accounted for by the many sources of error in the use of this standard, the charring of the wick, the irregular consumption of oil, and the use of a glass chimney. Even in the hands of a single observer successive measurements vary widely.

The British Candle.—The so-called English Parliamentary candle of spermaceti was not more scientific, and hardly more accurate, than the barley-corn, of which three went to the inch. That candle, six going to the pound (but neither length nor diameter being specified), and intended to burn 120 grains of sperm per hour, was set up under the Metropolis Gas Act of 1860 as an official standard, only for the purpose of testing London gas.

The German Candle.—In 1868 a carefully specified candle of paraffin was officially adopted by the German Association of Gas and Water Engineers, and was called the *Vereinskerze*. It was practically the same as the British candle.

The Harcourt or Pentane Lamp.—In 1877 Mr. A. Vernon Harcourt described a lamp burning air saturated with the vapour of pentane, a volatile hydrocarbon distilled from petroleum. This has undergone several modifications, and the present pattern, intended to represent ten times the candle-power of the Parliamentary candle, is the official standard of the Metropolitan Gas Referees, and the unofficial 10-candle British standard. A flat tank holds the liquid pentane, over the surface of which air passes, and becoming saturated with the heavy pentane vapour falls through a syphon pipe to a steatite ring or Argand burner. The flow is regulated by a tap on the outlet, or a valve on the air inlet of the pentane saturator. No wick

* See *Traité de photométrie industrielle*, A. Palaz, p. 101.

is needed. A tall chimney draws the flame up with a considerable draught and ensures a steady light. A second outer chimney, concentric with the first, warms the air which is supplied to the flame. No glass chimney is required, but the top of the flame may be inspected for adjustment through a mica window. The top of the flame is cut off in the direction of the photometer by a screen, giving a clear opening of 47 millimetres, but notwithstanding this, the height of the flame must be carefully adjusted. The total height of the apparatus is about 2 feet 10 inches.

The Hefner.—The amyl-acetate lamp, produced in 1884 by Hefner von Alteneck, was subjected to careful tests by Liebenthal, and after certain modifications was declared to be the official standard in Germany. The pattern certificated by the Reichsanstalt has been adopted by the American Institute of Electrical Engineers, and, provisionally, by the Bureau of Standards of the United States, and was recommended as an international standard at the Chicago Congress of 1893, but was not adopted, for reasons which probably do not exist now. It has been widely recognised for scientific as well as for industrial work.

The container, 70 mm. ($2\frac{3}{4}$ in.) diameter, made of brass, holds about 4 ounces (115 c.c.) of amyl-acetate. The ordinary commercial quality used as a solvent for celluloid is unsuitable, and even the commercially "pure" quality is apt to corrode the container. Unless this is well tinned or nickel-plated inside, a cock should be fitted for draining off the liquid after use. A thin German-silver tube, constructed to the exact dimensions

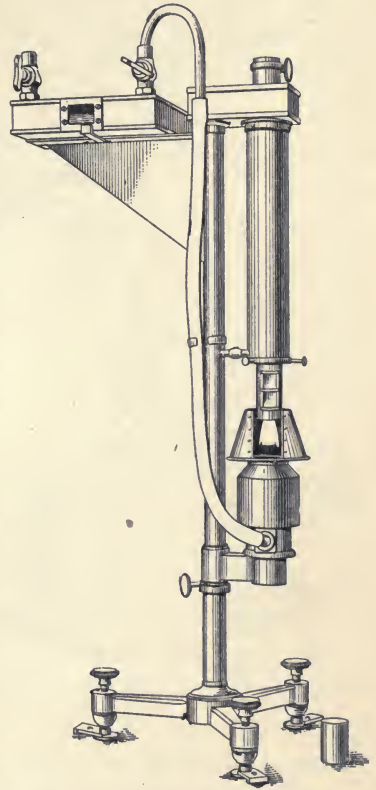

FIG. 1.—THE VERNON HARCOURT
PENTANE 10-CANDLE LAMP.

specified by the Reichsanstalt, holds the wick. Two toothed wheels, worked by worm gear, feed the wick, and give a fine adjustment for the height of the flame. A miniature camera with lens and ground glass is carried on a support at the side. A horizontal line is drawn on the ground glass, and the flame of the lamp is adjusted so that its inverted image just touches the line. The ordinary wick for spirit lamps may be used, but should be well dried; it should be carefully trimmed level with the top of the tube. The middle of the flame is 100 mm. (3.94 in.) above the bottom of the lamp.

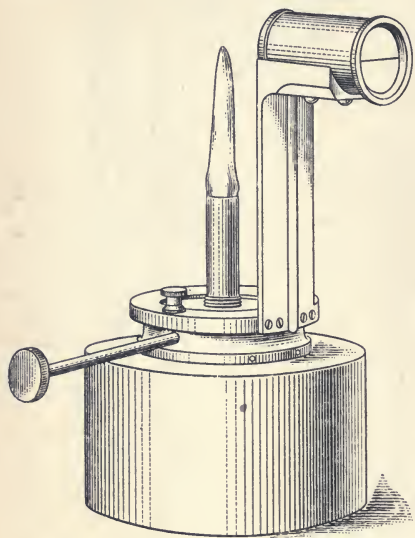

FIG. 2.—THE HEFNER AMYL-ACETATE LAMP.

causing an artificial upward draught.

Though the flickering of the flame sometimes makes it difficult to check its height on the gauge, it has not so much effect on the candle-power as might be supposed.

Liebenthal's statement of the relation between the height of the flame and the luminous intensity is an equation which means that when the height of the flame is less than 40 mm., each millimetre change of height causes 3 per cent change in light; and when the flame is more than 40 mm. each increase of a millimetre produces $2\frac{1}{2}$ per cent change. No doubt these two linear relations are good tangent approximations, but it is not

The temperature of the flame, which is of an orange colour, closely resembling that of a sperm candle, is remarkably low, and owing to the feeble draught, the flame is sluggish and sensitive to very small currents of air. It is not difficult to screen it, and the screens, which should always be used in photometric work for keeping the eyes in a sensitive condition, may be arranged to protect the flame without

possible to imagine a change *per saltum* at 40, which is the most important point. Mr. J. W. Dibdin found that the height of an amyl-acetate flame had to be increased to 51 millimetres to give one candle-power. This, according to Liebenthal's formula, would mean that one candle-power is equal to 1.275 Hefner unit. It is difficult to account for this discrepancy.

Assuming that a change of 1 mm. in the height of the Hefner flame changes the light by $2\frac{3}{4}$ per cent, a height of 44 mm. will correspond with the British, American, and French candle-power. This difference is too great to be marked on the ground glass of the gauge, but an adapter can easily be made to raise the whole gauge 4 mm. I have sent a lamp so altered to the National Physical Laboratory, and after applying the Liebenthal correction for moisture (from 12 litres per cubic metre at which the test was carried out, to 8 litres) and a small correction for barometer, the value in British candle-power was found by Mr. C. C. Paterson to be 0.995. The lamp burns perfectly well at this height.

The Violle.—More than one attempt has been made in France to set up the standard invented by Violle, and proposed for international adoption at the Electrical Congress at Paris in 1881. The standard is the light emitted in the normal direction by one square centimetre of the surface of molten platinum at the temperature of solidification. The cost of the apparatus is as formidable as the difficulty of using it. In the earlier patterns about one kilogramme of platinum was melted in a crucible of lime by an oxy-hydrogen blowpipe. When a quantity of water begins to freeze the temperature remains practically constant until it is all converted into ice. The same thing happens when a metal solidifies, and this condition must be seized upon for the photometric measurement. A considerable mass of metal is needed to delay the process for a period long enough to allow photometric observations to be made. The crucible was run out from below the blowpipe, and brought beneath a hollow water-cooled screen of copper in which a circular hole one square centimetre in area allowed the light to ascend to a mirror. Dust, scum on the molten surface, the ascending

current of hot air, and other difficulties have not only prevented the Violle standard from coming into use, but have left its value in terms of other standards uncertain. It has been assumed that the Violle was equal to about 2 Carcels.

As long ago as 1844 Draper proposed the use of an incandescent platinum wire for a standard of light, and the idea was so attractive to electricians that Zöllner, Schwendler, Werner von Siemens, Liebenthal, Lummer, and Kurlbaum, and finally Petavel, have spent much labour, but have produced little practical result. Petavel's researches* show the extreme difficulty of working with molten platinum. It has been left for many years to various International Congresses of Electricians to deal in a desultory fashion with the question of a standard of light. Like the mercury ohm, the Violle standard has been officially adopted again and again at International Congresses by people who had never tried to construct or even to use one, and who were unaware that far greater accuracy may be obtained by less academical methods.

The Bougie-Décimale.—The only other standard which need be mentioned is the bougie-décimale proposed at the Geneva Congress of 1896. It was considered to be approximately one-twentieth of the Violle, or one-tenth of the Carcel.

The Relative Values of the Standards.—The generally accepted value of the Hefner unit (H.U.) for many years was 0.88 candle-power. At a photometric meeting at Zurich in July 1907, at which several laboratories were represented, the following values were suggested:—

Carcel	=	10.7 ₅	Hefner.
Pentane	=	10.9 ₅	Hefner.
Pentane	=	1.02 ₀	Carcel.

This made the Hefner 0.913 candle-power instead of 0.88. The difference of more than $3\frac{1}{2}$ per cent seems to be accounted for by the fact that the Pentane or Harcourt lamp was standardised by many comparisons with the British "Parliamentary" candle used in the authorised method. The candle was cut in two, and one half was turned with the thick end up (for it was

* *Proc. Roy. Soc.*, 1899, lxx. 469, and *Journ. Inst. Elec. Eng.* xxxiii. 175 (1902).

tapered), and the other with the thick end down, and both were burned together mounted on a balance. The rate of consumption was ascertained, and a correction made for any difference from 120 grains per hour.

But this was not in accordance with German ideas. It was settled therefore that instead of taking loss of weight into account, the height of the flame should be 45 mm., and if the candle-flame ventured to rise above this limit, the wick was snuffed!*

In America a unit of candle-power was adopted based on the Hefner lamp as a standard, and using the reduction factor 0.88.† The work of attempting to bring about international-agreement as to a standard, or failing that, as to a unit of light, was undertaken in 1908 by The International Electrotechnical Commission. Comparisons were made between the National Physical Laboratory, the Bureau of Standards, Washington, the Laboratoire Central d'Électricité, Paris, and the Physikalisch-technische Reichsanstalt, Berlin, and in April 1909 the Bureau of Standards, Washington, announced that in order to come into agreement with the British and French units the American standard candle-power would be reduced by 1.6 per cent. The bougie-décimale was recognised as practically equal to one-tenth of the Pentane Harcourt standard, and this value was called the Pentane candle. The Pentane candle, the bougie-décimale, and the American candle thus became identical, and were declared to be 1.11 of the Hefner unit and 0.104 of the Carcel. The Hefner therefore becomes 0.9 of the new unit, which, it is hoped, may be called the International candle. The relative values may be arranged as follows:—

	International Candle.	Hefner.	Carcel.
International candle	1.0	1.11	0.104
Hefner	0.9	1.0	0.0936
Carcel	9.62	10.68	1.0

Corrections for Flame Standards.—Flame standards are

* Liebethal, *Praktische Photometrie*, p. 106.

† E. P. Hyde, "Comparison of Units of Luminous Intensity," *Bulletin of Bureau of Standards*, Washington, vol. iii. No. 1 (1907). See Paterson in Bibliography.

affected by atmospheric pressure, by aqueous vapour, by deficiency of oxygen, and by excess of carbon dioxide, but not by any ordinary differences of temperature. The standard atmospheric pressure is 760 mm. or 29.92 inches of barometer. Pure atmospheric air contains 20.93 per cent of oxygen and 0.03 per cent of carbon dioxide. In Germany the standard proportion of aqueous vapour is 8.8 litres per cubic metre, or 0.88 per cent by volume of air. In connection with the agreement on the round number 1 candle-power = 1 bougie-décimale = 1.1 Hefner, the standard of 8 litres per cubic metre or 0.8 per cent has been adopted by the principal British, American, and French laboratories.

Experiments carried out over large ranges by W. J. A. Butterfield, J. S. Haldane, and myself have shown that in the neighbourhood of 760 mm. the light of a Pentane lamp increases from 10 to 10.1 for an increase of pressure of 12.5 mm. (*i.e.* 760 to 772.5), or 0.8 per cent for an increase of 10 mm., and of course decreases correspondingly when the pressure falls.* It decreases by 1 per cent for an increase of about 0.035 per cent of CO₂ when the CO₂ is produced in the usual way by respiration and flame, and is thus accompanied by the corresponding fall in oxygen percentage. It decreases 1 per cent for an increase of 0.16 per cent in the aqueous vapour. It should be borne in mind that in a photometer room the air hardly ever contains so little moisture as 0.8 per cent or as little CO₂ as 0.03 per cent.

The correction for pressure in the case of the Hefner lamp is 0.4 per cent of light for a difference of 10 mm. in pressure, or exactly half of the correction for the Pentane lamp, but Liebenthal † makes it 0.1 per cent. The correction for aqueous vapour for the Hefner does not differ appreciably from that for the Pentane. The corrections may be expressed in two ways.

The following changes from normal make 1 per cent decrease of light :—

* The full account of these experiments was not ready for publication when this book went to press. At 650 mm. pressure the 10-candle Pentane lamp corrected for CO₂ and moisture gave 9 candle-power, and at 580 mm. pressure 8 candle-power.

† *Zeit. für Instrumentenkunde*, xv. 157 (1895); and *Praktische Photometrie*, p. 117.

	Pressure.	CO ₂ .	Aqueous Vapour.
Pentane .	- 12.5 mm.	+ 0.035 %	+ 0.16 %
Hefner .	- 25.0 ,,	+ 0.045	+ 0.16

Percentage difference of light for changes from normal :—

	Pressure.	CO ₂ .	Aqueous Vapour.
	10 mm.	0.01 %	1.0 %
Pentane . . .	0.8 ,,	0.29	0.625
Hefner . . .	0.4 ,,	0.22	0.625

Our results agree with those of Paterson* for pressure and very nearly so for aqueous vapour. Aqueous vapour should be measured by a wet and dry bulb thermometer exposed to a brisk draught by means of a fan, or by swinging the thermometers. Glaisher's tables may be used. The determination of CO₂ volumetrically by the Haldane apparatus† is not a difficult operation, but in general it is better to reduce the CO₂ to a negligible amount by good ventilation.

The Advantages of the Pentane and the Hefner.—The two rivals at present are the Pentane and the Hefner, with the Carcel in the background as a venerable relic, and the Violle as an unattained ideal of the future. The advantages of the Pentane for testing gas are very considerable, since correction of this lamp for variations of barometric pressure, moisture, and carbon dioxide present in the air, practically cancels out against similar variations in the light of the gas under test. For accurate work against electric light these corrections must be applied. The 10-candle size of the standard is convenient, the colour of the light is good, and slight variations in the specific gravity of the pentane are not serious. The disadvantages are the importance of the necessary corrections and the large size of the apparatus. The barometric and hygrometric corrections do not constitute a serious disadvantage in a well-equipped laboratory where work of high accuracy is carried on.

The advantages of the Hefner are that it needs somewhat smaller corrections than the Pentane, it is inexpensive, easy to use, is only $2\frac{3}{4}$ inches in diameter, and 5 inches high, and it is

* *Journ. Inst. Elec. Eng.* xxxviii. 272.

† *Journ. of Hygiene*, i. 109 (1901); and *The Analyst*, xxxiv. 255, 1909.

widely recognised as a practical unit. The objections to it are the orange colour of the light, and that a one-candle standard is not so useful as a 10-candle.

The Arc Standard.—The idea of screening a flame, and allowing the light from a definitely measured portion to be used as a standard, originated with Methven, who screened an Argand gas flame to give 1 or 2 candle-power. The same system is used in Harcourt's Pentane lamp. Violle used a screen with an aperture of one square centimetre. In 1892 Mr. J. Swinburne and Prof. S. P. Thompson independently suggested that a screen having an aperture of one square millimetre should be used with an electric arc, and it was thought that the temperature of the carbon would be uniform, being that of its volatilising point, and this would cause a standard quantity of light to pass. I had already made a very rough estimate based on a research with a different object.* In that research I was concerned only with relative photometric measurements. These were sufficiently exact for the purpose in view, but the value of the standard was not of importance, and was not verified. The values 64 to 70 candle-power per square millimetre were deduced from the area of the visible part of the crater or incandescent surface of the positive carbon. I at once attempted to investigate the proposed unit of light, and at about the same time Prof. A. Blondel conducted a similar but independent research.

A little study of a well-focussed image of the crater of a continuous-current arc, enlarged about 20 times, showed that the brightness of the surface was by no means uniform, and that somewhat erratic changes took place. A bright spot was often seen near the middle of the crater. It was always more noticeable when the arc was humming, but disappeared and was replaced by flashing patches when the arc hissed.

For the purpose of reducing the light by a definite proportion, I used the rotating sector so largely employed by Sir W. de W. Abney, and found that the image on the screen was often covered with shadows connected in some way with the

* *Journ. Inst. Elec. Engs.* xxi, 360; and *Chicago International Congress*, 1893; *The Electrician*, xxxi, 592 (1893).

sector. A rotating disc allowing the beam to pass for about 1-1000th of a second, and to be cut off for about 1-100th of a second, revealed a bright patch occupying about one-quarter of the crater, revolving about 100 times per second, seldom faster than 450 per second, and difficult to distinguish below 50, though Mrs. Ayrton has observed what is probably a different kind of patch revolving slowly enough to be seen without the stroboscopic disc.* The maximum brightness was about 170 candles per square millimetre. A fair average is 150.

Circumstances prevented my further investigation of this phenomenon, but it introduced an unexpected and apparently insuperable objection to the use of the proposed standard of light.

Radiation Standards.—Lummer and Kurlbaum in Germany † and Petavel in England have endeavoured to use as a standard the light emitted by one square centimetre of the surface of platinum when raised to such a temperature that 10 per cent of its radiation would pass through, and 90 per cent would be absorbed by the thickness of two centimetres of water in a glass cell. The adjustments are difficult. This and the Violle standard seem to share a sort of superior quality, and claims for regarding them as “physical units” have been made on the strength of their dependence on a square centimetre, and a noble metal. The real claim of a standard for recognition must lie in its practical and exact reproducibility. The actual magnitude is of no consequence, since the low mechanical equivalent of light puts a centimetre-gramme-second unit out of the question.

Glow-Lamp Sub-Standards.—While there are practical advantages in using a flame standard such as the Harcourt or Hefner, or even the Carcel, for measuring the intensity of flame-sources of light, electrical engineers and most physicists prefer an electric glow-lamp as a practical standard, whatever the ultimate or official standard may be. Fleming has given

* *Proc. Roy. Soc.* lvi. (June 12, 1894); and S. P. Thompson, *Cantor Lectures, Soc. of Arts*, xliii. 973-5 (1895).

† *The Electrician*, xxxiv. 37 and 77.

great care to the construction of such sub-standard glow-lamps. The difficulty is that secondary sub-standards must be provided and compared with the carefully standardised lamps, for the candle-power will inevitably alter with use. Another drawback is that very exact measurements of electric current must be made, and the source of this current must be a special secondary battery. The expense of the equipment is therefore considerable.

CHAPTER II

ILLUMINATION AND DERIVED UNITS

Illumination.—The next quantity to be considered is illumination. When light falls on a surface, that surface is said to be illuminated. The illumination depends simply on the quantity of light falling upon a given surface, and has nothing to do with the colour or reflecting power of the surface; just as rainfall is independent of the nature of the soil. When rain falls on an absorbent soil it quickly disappears, but the water stands on an impermeable soil. Illumination falling on a dark-coloured surface is absorbed and wasted, but when the same illumination falls on a light or white surface there seems to be “plenty of light.” A careful distinction must be observed, for two rooms may have identical illumination, and one may seem to be well illuminated and the other badly illuminated. There is no paradox here—the word “illumination” is properly used, and the word “illuminated” is misleading. It may appear pedantic to prefer the word “lighted” to “illuminated,” but when once a word has a well-defined scientific meaning, borrowed though it be from ordinary language, that meaning should be jealously guarded.

When the same illumination falls, say, on white paper and on brown paper the result is, of course, very different; the brightness resulting from illumination has been called luminosity by Abney.

The Foot-Candle.—Illumination consists of two factors, candle-power and distance. The illumination produced by

1 candle-power at the distance of 1 foot is the unit recognised in England and America—it has generally been called the candle-foot. It was used by Sugg about 45 years ago.* In France the unit is naturally the Carcel-metre, and it has been in use since 1882. During the last few years the name foot-candle has been used in America. Either name is unfortunate, because, unlike all other compound units, such as the foot-pound, the quantity is not the product of candle-power into length, but it is the quotient, and the divisor is not a length in feet, but the square of a length, for the illumination of 1 candle at 1 foot is equivalent to 4 candles at 2 feet, or 9 candles at 3 feet. The “candle-power-foot” used by some writers is quite unnecessary, and the “candle-per-square-foot” used by others is a confusion for “candle-per-foot-squared” advocated by Carl Hering.† This seems to be a mistaken expression; it can be supported only by the introduction of unnecessary dimensions, for the square comes in arithmetically and not as an area. Many years ago the editor of *Industries* quarrelled with the candle-foot, and suggested, after the fashion of Lord Kelvin’s “mho,” that it should be called a “candle-toof-toof.” There is something to be said for a “candle-at-a-foot,” but perhaps the name “foot-candle,” which is always used in America, is the best, for twice this illumination becomes “two-foot-candles,” and the candles appear to be multiplied, which is not so misleading as “two-candle-feet,” where the candle remains single and the foot becomes plural. The *Meterkerze* used in Germany has probably been adopted for this reason. I objected to the name when I first encountered it, but I propose to adopt it in future, for the reason which is given here. The symbol in writing may clearly be c/f^2 .

The foot-candle is a very convenient and comfortable illumination. It is for most people a sufficient illumination for reading, and is to be found on most well-lighted dining-room tables and billiard tables. More than 5 foot-candles is seldom attained in artificial illumination.

* *Proc. Inst. Civ. Engs.* cx. (1894).

† *Ready Reference Tables*, Carl Hering, p. 148.

The Lux.—All this confusion would be avoided by the recognition of a special name for the unit. Sir William Preece, the first engineer in this country to give attention to the measurement of illumination, adopted the Carcel-metre, and he showed* that it was equal to a standard candle at 1.058 foot. At the Paris Electrical Congress of 1889 he proposed the name “lux” for this. Owing to the general apathy with which the subject of the distribution and measurement of illumination has been regarded, neither the name nor the unit came into use. The unit of illumination produced by a bougie-décimale at a metre has been called a bougie-metre, and the name “lux” was revived at the Geneva Congress of 1896 and was applied to this unit. In such a case, a name gets over the difficulty of a compound word. This lux is, roughly, one-twelfth of a foot-candle, or about one-fourteenth of Preece’s lux.

The illumination produced by a Hefner at a metre has also been called a “lux,” and it seems probable that the International candle at a metre may be called an International lux. The following table is an abstract of a larger one by Dr. B. Monasch :—†

	International Foot-Candle.	International Metre-Candle.	Metre- Hefner.
International Foot-candle .	1	10.76	11.95
International Metre-candle .	0.0929	1	1.11
Metre-Hefner (<i>Meterkerze</i>) .	0.0837	0.9	1

For practical purposes 1 foot-candle is equal to 11 International metre-candles and to 12 metre-Hefners. So long as the Hefner unit remains, the confusion between the metre-candle and the metre-Hefner makes the use of the term “lux” ambiguous, and the foot-candle will be used in this book.

The Law of Inverse Squares.—The law of inverse squares ‡ is easy to understand, but the arithmetical application is not so obvious. To say, off-hand, how many foot-candles are

* *Proc. Roy. Soc.* xxxvi. 276. This was based upon 9.6 candle-power for the Carcel.

† *The Illuminating Engineer*, ii. 742.

‡ The explanation of the law of inverse squares given by Mr. J. W. Dibdin in his *Principles of Photometry* (p. 15) can hardly be improved upon :—

“Let it be assumed that the four diverging lines enclose a number of rays of light proceeding

produced by a 16-candle lamp, at a distance of 8 feet, is rather puzzling at first. The illumination is $\frac{16}{8^2} = 0.25$ foot-candle. Taking the Hefner at 0.9 candle-power and the metre at 3.28 feet, the Hefner-lux is $\frac{0.9}{3.28^2} = 0.0837$ foot-candle, and the foot-candle is 11.95 Hefner-lux.*

These calculations are easily done on a slide-rule. Fig. 4

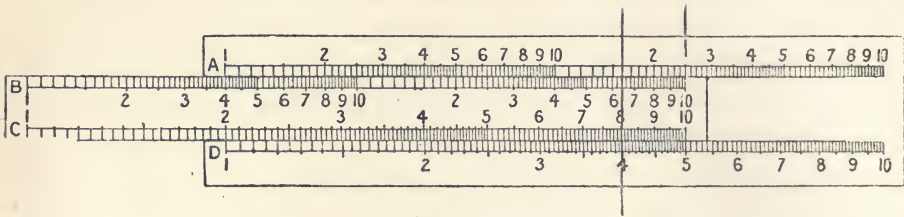

FIG. 4.

shows a slide-rule with 8 (feet) on the C scale set below 16 (candle-power) on the A scale. Then above 1 on the C scale find 0.25 on the A scale. To find how much candle-power at 5 feet will produce 0.25 foot-candle, with the rule set as in Fig. 4 over 5 on C, find 6.25 on A, or for 50 feet, 625 candle-power.

Fig. 5 shows a slide-rule set with 3.28 (feet = 1 metre) on C, set below 0.9 (candle-power = 1 Hefner) on A. Then above 10 on A read 1 Hefner-lux = 0.084 foot-candle, and below 1 on A read 1 foot-candle = 11.95 Hefner-lux.

from the radiant A. At a distance of one foot, the whole of these rays would fall upon a screen of small dimensions. At twice the distance they would illuminate a surface four times the size of the first screen; and consequently the volume of light impinging upon a screen the same size as that at one foot distance would be only *one-fourth*. At three feet distance, the whole of the rays would have spread, so that a screen nine times the size of the first would be required to arrest them all, and therefore

our small screen, if removed to that position, would receive only *one-ninth* of its primary illumination."

* With the old value, Hefner = 0.88 c.p., the lux is 0.0818 foot-candle, and the foot-candle 12.2 lux.

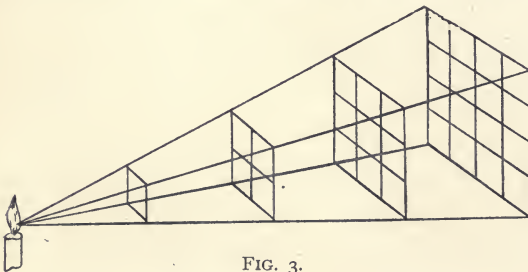

FIG. 3.

The Cosine Law.—The foot-candle, as already defined, assumes that the illuminated surface directly faces the source of light. If the surface is inclined to the direction of the rays of light, the illumination will diminish in proportion as the projected area of the surface diminishes when viewed from the source of light. The visible surface varies from unity, as seen full, to nothing when seen on edge. It is a well-established convention among writers on optics (but it is only a convention)

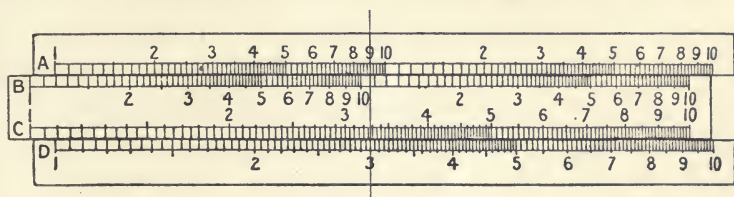

FIG. 5.

that the inclination between a ray and the perpendicular to a surface shall be called the angle of incidence.* This angle will frequently be alluded to and will be designated where necessary by θ . A ray proceeding horizontally, parallel with the ground, will therefore be of 90° incidence, and a ray falling on the point immediately below a lamp will be of 0° incidence on the horizontal plane beneath it.

Let a parallel beam of light pass through a hole AB (Fig. 6) 1 foot square, and fall on a screen CO parallel with the screen AB, and perpendicular to the direction of the beam, that is, with angle of incidence 0° . Let the value of the illumination on CO be called 1. Then let the screen be tilted through 60° to the position DO. It is evident that the illuminated area on the screen is *increased* from 1 square foot to 2 square feet. The illumination being spread over twice the area, the value is

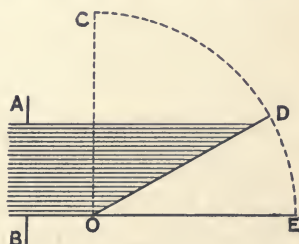

FIG. 6.

* The old writers took the inclination of the ray with the surface as the angle of incidence. Lambert, writing in 1770, enunciated this law as follows: "Quare illuminatio normalis erit ad illuminationem obliquam ut sinus totus ad sinum anguli incidentiae. Eo igitur minor erit quo minor est anguli incidentiae sinus."—*Phometria*, p. 27.

therefore diminished one-half. The angle of incidence is 60° ; the cosine of 60° is 0.5; turn the screen through another 30° to OE, or through a right angle with its first position; the light passes by, and theoretically none falls on the screen; the illumination is 0; the angle of incidence is 90° ; the cosine of 90° is 0.

In Fig. 7 let AO, BO, DO, FO, and HO be successive positions of the screen. Let BC, DE, FG be perpendiculars dropped from the points B, D, and F. Then AO being unity, these perpendiculars measure the cosines of the angles through which the screen is turned, and are proportional to the illumination of the screen. This is Lambert's cosine law, to which reference will frequently be made. Another aspect of this is to consider how the area of the screen, as seen from the direction in which the light falls, diminishes. It is unity at AO, and becomes zero at OH.

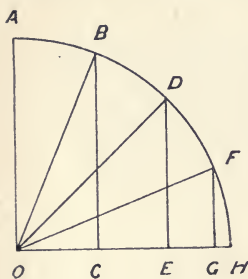

FIG. 7.

Mean Spherical Candle-Power.—Conceive a source of light to be surrounded by an imaginary sphere, and many points to be taken uniformly distributed over the surface of the sphere, and the candle-power to be measured in the direction of each of these points, then the average of all the measurements is the mean spherical candle-power. So long as the candle-power is sensibly the same in all *useful* directions, there is no advantage in considering the mean spherical candle-power. When the candle-power is widely different in different directions, as in the case of a continuous-current open arc, the mean spherical candle-power gives very little useful information. It is like trying to describe the performance of a steam-engine by giving the mean pressure in the cylinder. On the other hand, for those who know the kind of distribution of light, as in the special case mentioned, the M.S.C.P., as it is called, is better than giving the maximum candle-power, as was the custom in the old arc-lamp days of the early 'eighties. Since such an arc gives practically no light at all in the upper hemisphere, the

mean hemispherical candle-power is sometimes used. The horizontal candle-power of ordinary electric glow-lamps does not differ more than about 15 per cent from the M.S.C.P. This subject will be examined in more detail in Chapter VII.

Flux of Light or Total Light.—There are three ways in which rainfall may be measured. The average annual rainfall on Great Britain may be described as 115,200 cubic feet, or 3200 tons per acre; or as standing with a vertical section of 2.65 square feet on each lineal foot. (The flow of a river in cubic feet per second is found by multiplying the area of the vertical section in square feet by the average velocity in feet per second.) Or it may be simply stated as 32 inches. The first way employs three dimensions of water and two of land; the second suppresses one of each of these dimensions, and leaves two of water and one of land; the third way again suppresses one of each of the dimensions, and leaves one of water and none of land. The last is of the nature of an intensity.

It may be argued that the first is the true way, for it alone deals with a real quantity of water; and the other ways are abstractions. Similarly, it has been suggested that the true way to measure light is as a flow of luminous energy. But the difference is one of suppressed dimensions.

Professor Blondel, who has written so lucidly on photometric magnitudes and units,* cites an American story to show that the flux of light is instinctively felt to be the fundamental quantity in photometry, and that it is misunderstood simply because no name for a unit of it has been recognised. “An expert, called in to interpret a clause in an electric-lighting contract between a town near New York and the local electrical company, with regard to some 2000 nominal candle-power arcs, expressed his opinion as follows: ‘The arc lamps are suspended at the cross roads, and each one, therefore, sends its light out in four directions; one cannot, therefore, expect to get 2000 candles in each direction. The 2000-candle arc arranged for in the agreement was one sending 500 candles down each road.’ We

* *The Electrician*, xxxiii. 633 (Sept. 28, 1894), and *Report presented to the International Congress of Electricians*, Geneva, 1896.

do not wish to make fun of this expert," adds Blondel, "for in truth he is a very sensible man."*

A source of light capable of giving 1 candle-power in every direction, placed in the centre of a sphere of 1 foot radius, will give an illumination of 1 foot-candle over the whole surface. That surface is 4π , or 12.56 square feet. Some writers have wrought great confusion by saying that the light of such a source is 4π candles, or 12.56 candles. No such photometric quantity as a "candle" exists. Their reasoning is generally in a circle, and they come back to ordinary candle-power again after a mess of unnecessary mathematics.

No enterprising lamp manufacturers could excuse themselves for offering lamps as "201 candles," by explaining that they give $4\pi \times 16$ candle-power. If we say that the flux is 4π times the candle-power we make no advance, and if we say that the "total light" is 4π candles we are likely to be misunderstood. We should, if possible, avoid introducing unnecessary dimensions if they have to disappear in the final result.†

In the case of electric arc lamps with vertical carbons the candle-power varies in different directions in any vertical plane, but, except for accidental irregularities, it is the same in each such plane. If the candle-power at various angles with the horizon is measured, the mean spherical candle-power may be calculated by certain methods which will be described. These involve the consideration of 4π and the solid angle; we have to hamper ourselves with dimensions, but get rid of them in the result. Mean spherical candle-power, so far as candle-power is concerned, is nothing more than the average candle-power in all directions, and has nothing to do with flux.

The quantity 4π , multiplied by the luminous intensity or candle-power, has been called by Blondel a lumen. It may

* I told this story to a very intelligent lady, and, by request, repeated it three times. She said, "I give it up; I don't see anything funny in it."

† "The standard candle, which ought to give a light of 4π , is about as absurd as the horse-power. The candle and the horse are about equally obsolete, and the candle is about as likely to give a candle-power—or 4π units of British light—as a horse to give a horse-power. The horse has one advantage over the candle; he is not inextricably mixed up with the 4π controversy, and well-meaning people do not try to rationalize him as a unit."—J. Swinburne's Presidential Address, *Journ. Inst. Elec. Eng.* xxxii. 39.

perhaps deserve a name. Meanwhile "mean-spherical-candle-power" must serve for both. The flame of a candle pours out energy, partly luminous and partly non-luminous. The total light may be measured as a rate of emission of luminous energy. This is an instantaneous value. The product of this by time would give a quantity in terms of energy.

This product of candle-power into solid angle has an application in connexion with distribution of illumination, and another in connexion with the diffused reflecting power of a dead or matt surface, or with the analogous case of the transmission of light through opal glass or paper. The elementary geometry of this will be dealt with in a later section.

Brightness or Intrinsic Brilliancy.—Brightness or intrinsic brilliancy is generally applied to a surface which emits light, and illumination or luminosity to one on which light is received. Brightness may be of three kinds. (1) The brightness of a transparent luminous body, such as a flame. (2) The brightness of a solid luminous body, such as a piece of incandescent metal or carbon. (3) The brightness of a matt or rough body which reflects light in all directions, but in a manner depending on the nature of the body and its surface. An example may be given of the first kind. The hole in the screen which Methven placed in front of his Argand burner, burning non-carburetted gas, was 0.233 square inch in area. This gave a standard of 2 candle-power. The brightness of this part of the flame was, therefore, 8.6 candle-power per square inch. A candle flame is approximately a triangle 0.4 inch wide at the base, and 2 inches high (10 mm. × 51 mm.); it has, therefore, an intrinsic brilliancy of 2.5 candle-power per square inch.

	Per square inch.	Per square mm.
Sun	800,000	124,000
Arc	1,030	160
Osram lamp	1,000	150
Tantalum lamp	420	66
Carbon lamp	200 to 50	31 to 7.8
Candle	2.5	.39
Moon	2	.31

Quantity of Light and Quantity of Illumination.—Blondel

has suggested the lumen-hour as a unit on which commercial contracts for lighting may be based, but there seems to be no pressing need for such a unit. A foot-candle-hour is a much more useful unit. The result in foot-candles is what is wanted, the mean spherical candle-power-hour is only a means to an end. At the International Photographic Congress at Brussels in 1891 the "bougie-metre-second" was adopted. Every photographer consciously or unconsciously uses a "time-illumination" unit, for this quantity is nothing more or less than what he calls "exposure." An illumination of 5 foot-candle-seconds gives a sensitive shade of grey on ordinary slow bromide paper.

Diffused Reflection.—When a beam of light strikes a mirror or polished reflector, its direction is changed by reflection and it proceeds in a direction depending on the angle at which it struck the mirror. But when a beam of light falls on a rough unpolished surface the result is very different. If the surface is quite devoid of polish, the reflected light leaves it in all directions, and the quantity of light is greatest in the direction normal to the surface. In other directions it is approximately proportional to the cosine of the angle with the perpendicular. A *perfectly* white unpolished surface of an area of π square feet receiving an illumination of one foot-candle, or an area of one square foot receiving an illumination of π foot-candles, reflects one candle-power normally, and has a hemispherical candle-power of one half-candle. A circle of one foot radius, or the projected area of a globe of one foot radius, has an area of π square feet. A milk-white globe of one foot radius, emitting one candle-power in all directions, would be indistinguishable from the reflecting disc or globe. The intrinsic brilliance would be one foot-candle.

If lights amounting to 100 candle-power are placed in a room having walls, floor, and ceiling of a reflecting power of 80 per cent, one-fifth of the light will be absorbed and four-fifths will be reflected. This reflected light is for all intents and purposes a new light of 80 candle-power. It will fall on the sides of the room; one-fifth will be lost and four-fifths, that is,

64 candle-power, will be reflected. The total effective candle-power* in the room will be

$$100 (1 + 0.8 + 0.8^2 + 0.8^3, \text{ etc.}).$$

Now $1 + 0.8 + 0.8^2 + 0.8^3$ carried *ad infinitum* is

$$\frac{1}{1 - 0.8} = 5.$$

The total effective light in the room is therefore the same as if the walls and ceiling had been black, and 400 lamps of one candle-power each had been spread evenly over the walls, in addition to the original 100 candle-power. This is worth having. But if the reflecting power had been 75 per cent instead of 80, the effective candle-power would have been 400 instead of 500, and with a reflecting power of 40 per cent, it would have been only 166. This shows that the choice of the colour of the walls and ceiling of a room is worthy of careful consideration.

It is rather difficult to measure the reflecting power of a surface by illuminating one square foot of it until it gives a measurable candle-power, but by making equivalent measurements W. E. Sumpner † has determined the reflecting power of many different substances. The first four of the following list were found with great care, the remaining ones are approximate, as they cannot be accurately specified:—

White blotting paper	82 per cent.
White cartridge paper	80 "
Tracing cloth, polished side	35 "
Tracing paper	22 "
Ordinary foolscap	70 "
Ordinary newspaper	50 to 70 "
Yellow wall paper	40 "
Blue paper	25 "
Dark brown paper	13 "
Deep chocolate paper	4 "
Clean deal wood	40 to 50 "
Yellow painted wall, clean	40 "
Black cloth	1.2 "
Black velvet	0.4 "

Lambert gave the name albedo to diffused reflecting power.

* Mascart, *Traité de photométrie industrielle*, p. 268.

† *Phil. Mag.* xxxv. (1893) 88; and *The Electrician*, xxx. 381, 411, 439.

The word has been adopted by astronomers. Zöllner gives the following :—

Fresh snow	78 per cent.
White paper	70 „
Jupiter	62 „
Venus	50 „

If lamps backed with good reflectors are arranged to throw their light on white walls and ceiling, with a mean reflecting power of 75 per cent, and the lamps themselves are hidden by the reflectors, the illumination due to diffused reflection will be about twice as great as if the lamps had been unscreened, and the walls had been dark brown and the ceiling in shadow. We are accustomed to associate brilliant lighting with shadows ; every artist knows that the effect of sunshine is suggested by well-marked shadows, rather than by luminous colour. When a room is illuminated by diffused reflection there are no shadows, and this gives a peculiar and to most persons charming effect, though it makes the room appear to be less well lighted than it really is.

CHAPTER III

THE DISTRIBUTION OF ILLUMINATION

Distribution of Illumination on a Plane.—The case of the illumination of a horizontal plane by a light radiating uniformly in all directions is the most simple, and at the same time the most useful and common problem for outdoor work. The candle-power may be assumed to be constant, and need not enter into the matter. It will be taken as unity. The height of the lamp above the ground is also constant, and will also be taken as unity. The illumination at any point on the plane

varies inversely as the square of the distance from the light; that is, it varies inversely as the square of the slant distance of the lamp. It also varies as the cosine of the angle of incidence. In Fig. 8 it will be seen that the illumination at C

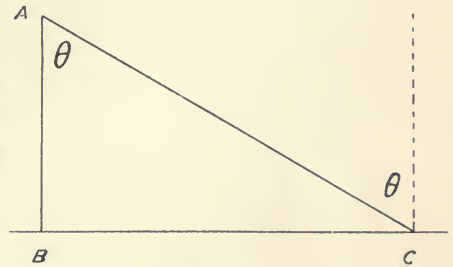

FIG. 8.

varies inversely as the square of AC, since AC is the slant distance, and it also varies inversely as AC, because, when AB is unity, the inverse ratio of AC is the cosine. The illumination will therefore be inversely as $AC \times AC^2$, or as the cube of the cosine of the angle of incidence. It is not necessary to measure or to know θ , the angle of incidence. The illumination at the point C being inversely proportional to the cube of AC and inversely proportional to the square of the height AB and to the candle-power of the light, is equal to

$$\frac{\text{c.p.} \times \cos \theta}{AC^2}$$

or

$$\frac{\text{c.p.} \times \cos^3 \theta}{AB^3}$$

The curve in Fig. 9 represents the illumination at any point on the horizontal plane by the height of the ordinate at that point, the maximum being unity. The tangent of the angle of incidence θ is the ratio of BC to AB (Fig. 8), and AB being considered here as unity, the tangent is the length BC.

The eye, after a little experience, is better able to judge degrees of illumination than of candle-power. Difficulties intro-

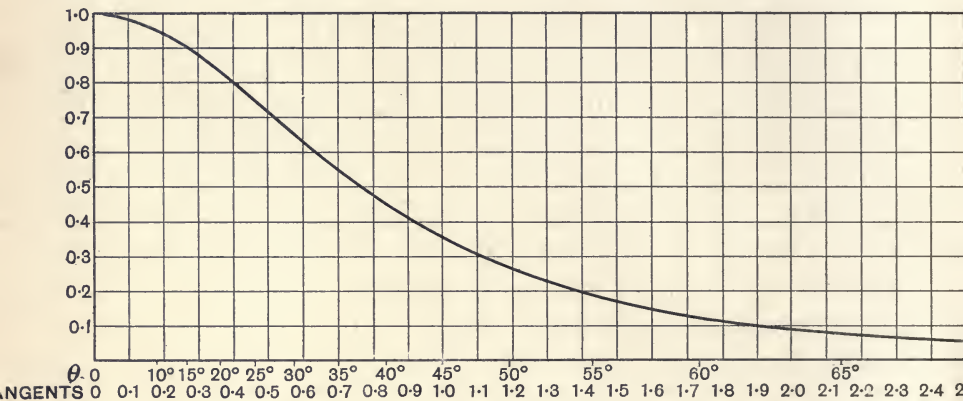

FIG. 9.—CURVE OF COSINES CUBED.

duced by brightness or intrinsic brilliance are absent, but small differences can only be estimated with the help of photometric apparatus. The small and gradual changes of illumination shown so clearly on Fig. 9 could not be estimated or even detected by the eye. Weber has shown that the intensity of visual sensation is not directly proportional to the luminous stimulus. Illuminations, or, indeed, any other sensations, cannot be quantitatively compared; but quality can only be estimated, and that very roughly, compared with other measurements.*

But gradual changes of illumination, imperceptible though

* Weber's law has been expressed thus: "The smallest change in the magnitude of a stimulus which we can appreciate through a change in our sensation always bears the same proportion to the whole magnitude of the stimulus. . . . This law holds good within certain

they may be, have an actual existence; and the tables given in the Appendix, originally to four figures, and now reduced to three, need not be regarded as aiming at extreme accuracy, but are provided as a basis for other calculations. Illumination on a horizontal plane decreases so rapidly with the distance, that at an angle of incidence of about 37° , or at a horizontal distance of three-quarters the height of the lamp from the ground, it falls off to one-half; at about 45° to one-third; and at 62° , or at a horizontal distance of nearly twice the height of the lamp above the ground, one-tenth of the maximum.

Theoretical Examples of Distribution.—By the means of the cosine law, and of the tables in the Appendix, the illumination produced by any given arrangement of lights may be found. The principal object of my original paper* was to attempt to enable engineers to predetermine, specify for, and provide a definite illumination. While it failed to be utilised in this way to any appreciable extent, other writers have from time to time calculated and published similar curves. Engineers may have considered these too laborious to apply in practical cases, and the illumination of streets, railway stations, etc., has been for the most part carried out either by adding to the number or to the power of the lights until the illumination was sufficient, or by trying experiments with lamps at various heights and distances. One excuse for this unscientific procedure was that in general nobody knew how much illumination was wanted.

limits only: it fails when the stimulus is either above or below a certain range of intensity."
—Michael Foster, *Text-Book of Physiology*, 5th ed. part iv. p. 1211.

Weber discovered this principle in certain special cases; Fechner proves that it holds for all kinds of sensations. The proportion for light sensation is about $1/100$, for muscle (*i.e.* judging weights) about $1/17$, and for pressure and sound about $1/3$. See Wundt's *Human and Animal Psychology*, Lecture II.; and P. C. Nutting, *Bulletin of Bureau of Standards*, Washington, iii. 59 (1907). The law may also be expressed in a mathematical form.

A distinction must be observed between the degree of accuracy with which a sensation may be estimated and the smallest perceptible distance between two sensations. Those who are not accustomed to estimating weights would have a difficulty in guessing which of two weights, one a pound and the other a pound and a quarter, was the pound, though, of course, one would appear distinctly heavier than the other. This corresponds with the difficulty of estimating the candle-power of a lamp by looking at it.

Fechner showed that most people can just perceive that a weight of 17 ounces is heavier than a weight of 16 ounces; but the difference between 30 and 31 ounces cannot be detected by muscular sensation; the heavier weight would have to be increased to about 32 ounces. This corresponds to the judgment in photometry, which Fechner puts at $1/100$.

* *Proc. Inst. C.E.* vol. cx.

The curve given in Fig. 9, and the tables of value of $\cos^3 \theta$, enable the curves for the combined effect of a number of lamps to be determined by the simple addition of ordinates. The curves given in Figs. 10 to 14 assume that the candle-power of each lamp is the same in all directions. They give the component and resultant curves for four different arrangements. The first, Fig. 10, represents the distribution of illumination on the ground due to a row of lamps at a distance apart equal to their height

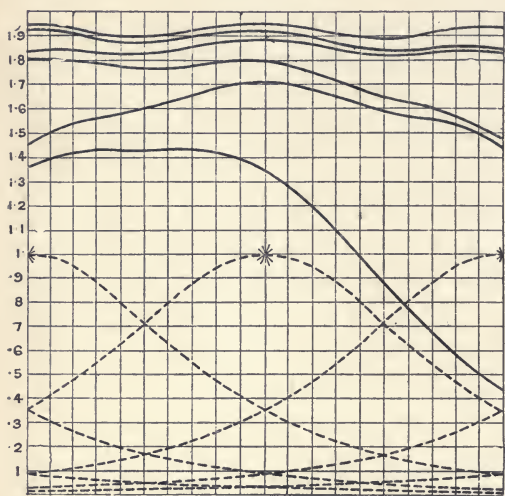

FIG. 10.—RESULTANT ILLUMINATION DUE TO LIGHTS AT A DISTANCE APART EQUAL TO THEIR HEIGHT.

apart equal to their height from the ground. The dotted lines are the $\cos^3 \theta$ curves, and the tails of the curves of the more remote lamps appear. The first full line shows the resultant illumination due to two lamps, and the next one above, a symmetrical portion being given, represents the illumination due to three lamps. The other lines similarly show the additional effect of more remote lamps. The horizontal scale is one of distances along the ground; the ordinates give illumination in an arbitrary unit, being the illumination which would be found below one lamp alone, if there were no shadow. It may be observed (but let no one who is thinking of using the method be alarmed by the statement) that the illumination at the maximum is $1 +$ twice the cubes of the cosines of the angles whose tangents are 1, 2, 3, 4, etc., and is 1.978 when there are four lamps on each side. The minimum illumination is equal to twice the cube of the cosines of the angles whose tangents are 0.5, 1.5, 2.5, 3.5, etc., and is equal to 1.932 for five lamps. The resultant curve is practically symmetrical about a horizontal line, and the mean illumination

may be taken as the arithmetical mean of the values. The eye could scarcely detect any variation in the illumination of the ground along the line of such a row of lamps, the difference being only $2\frac{1}{4}$ per cent.

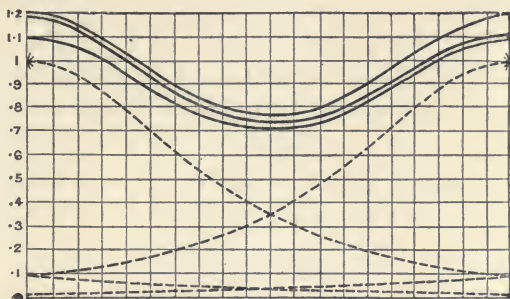

FIG. 11.—RESULTANT ILLUMINATION DUE TO LIGHTS AT A DISTANCE APART EQUAL TO TWICE THEIR HEIGHT.

The next arrangement, Fig. 11, is that of lamps placed at a distance apart equal to twice their height. The dotted lines, as before, are the curves of the separate lamps, and the full lines the resultants. The maximum illumination is 1.219, being $1 +$ twice the cubes of the cosines of angles whose tangents are 2, 4, 6, 8, and the minimum is 0.7836, being twice the cubes of the cosines of the angles whose tangents are 1, 3, 5, 7. The

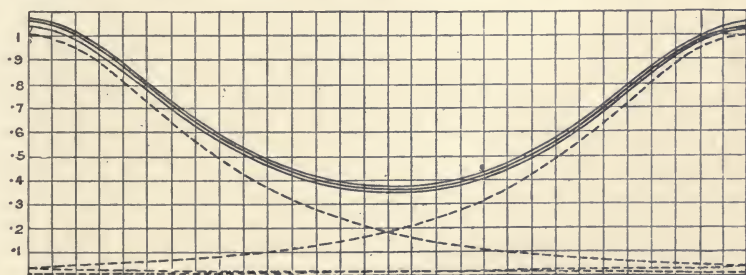

FIG. 12.—RESULTANT ILLUMINATION DUE TO LIGHTS AT A DISTANCE APART EQUAL TO THREE TIMES THEIR HEIGHT.

minimum is 35.8 per cent less than the maximum. The mean is practically unity. In the next arrangement, Fig. 12, the distance is three times the height. The maximum is 1.073, and the minimum is 0.362, being 63.8 per cent less than the

maximum. This variation is, of course, very marked, but is not nearly so apparent to the eye as is indicated by the curves. The last example, Fig. 13, is a common arrangement in street lighting, the distance apart being six times the height of the lamps from the ground. The maximum is 1.01, and the minimum is 0.0632, and the variation 93.7 per cent. The additional effect of only one lamp on each side has been considered. It is somewhat doubtful whether the mean illumination in these last two cases is a quantity worth considering, since the effect of such an illumination produced by a considerable number of smaller lamps, closer together, and approximating to that mean, would be very different.

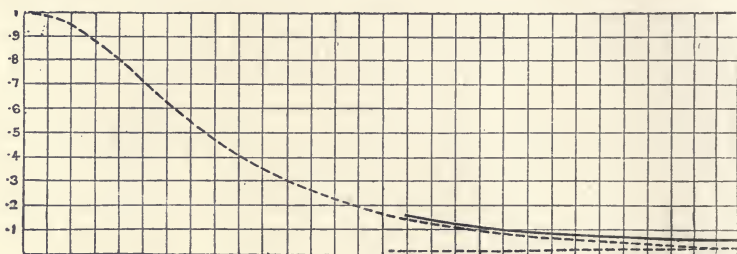

FIG. 13.—RESULTANT ILLUMINATION DUE TO LIGHTS AT A DISTANCE APART EQUAL TO SIX TIMES THEIR HEIGHT.

Two practical modifications must be considered with regard to these results: one is the non-uniformity of candle-power in different directions, due, in some cases, to the shadow of the gas burner or the frame of the lamp, or to the shadow of the lower carbon of an arc lamp; the other is the reflection of neighbouring walls.

Distribution of Illumination from an Arc Lamp.—The light of an ordinary continuous-current arc lamp is emitted in a well-defined manner, and when used with a clear glass globe or lantern, may be taken as a notable case of non-uniform candle-power. Fig. 14 gives a curve showing the variation in candle-power, and the resultant illumination produced. With angles of incidence from 0° to about 55° the light is more or less obstructed by the lower carbon.* Beyond 55° the light

* See page 148, and *Journ. Inst. Elect. Eng.* vol. xxi.

follows a regular law, but not that of the cosine cubed, for the light is not emitted from a point or (in the case under consideration, that of the ordinary arc) from a flame, but from the horizontal tip or crater of the upper carbon. The projected area of this disc, as seen from any direction, varies as the cosine of the angle. The cosine being thus introduced for the fourth time, the illumination beyond 55° incidence varies as the fourth power of the cosine. The whole curve of $\cos^4 \theta$ is given in Fig. 14 as far as a point $2\frac{1}{2}$ times the height of the lamp. The part between 55° and 0° is dotted. The total light or flux is π , and a right-angled cone contains half the flux.

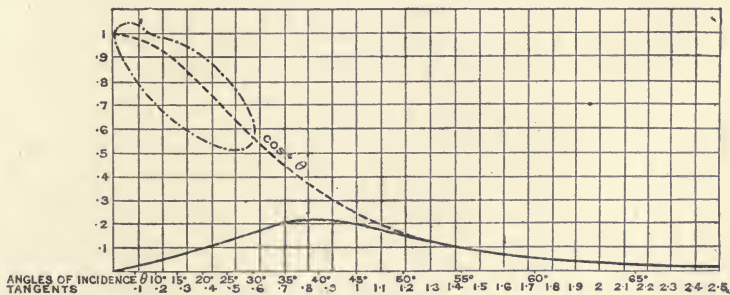

FIG. 14.

- Candle-power curve of arc lamp.
- Curve of $\cos^4 \theta$.
- Illumination curve of arc lamp.

In the foregoing curves (Figs. 9 to 14) the height of the lamp and the maximum illumination have both been taken as unity. This is an arbitrary convention, and is useful mainly in enabling the curves to be compared. When, owing to non-uniform distribution of the light, the maximum illumination does not occur below the lamp, this convention fails; but it is possible to retain the relation between the vertical and the horizontal scales by considering the illumination at some distance from the lamp. At angles of incidence greater than about 55° , it has been already shown that the illumination from an arc lamp on a horizontal plane varies as the fourth power of the cosine. The fourth power of the cosine of 45° is 0.25. If, then, the height of the lamp be set off on the

same scale of feet as the horizontal measurements, and if it be assumed that the maximum illumination measured on a vertical scale be represented by a height equal to 0.25 of the height of the lamp, illumination curves of different kinds

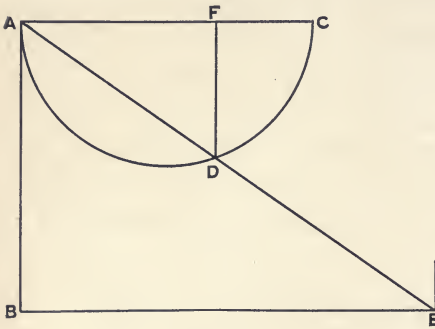

FIG. 15.

of lamps may be plotted together for comparison. Fig. 14 was constructed in this way. The flatness of the curve is rather a disadvantage.

Distribution of Illumination from a Vertical Filament.—

A metal filament electric glow-lamp may be considered to consist of one or more straight vertical filaments. The distribution of light from a source of this shape is a maximum in a horizontal direction, zero directly downwards, and at other angles proportional to the sine of the angle with the vertical. Let AB, Fig. 15, be the height of the lamp from the ground, and AC its candle-power in a horizontal direction. To find the illumination at the point E on the ground, draw EA, cutting the circle ADC at D. Then AD is the candle-power in the direction AE. Let the angle BAE = θ . If

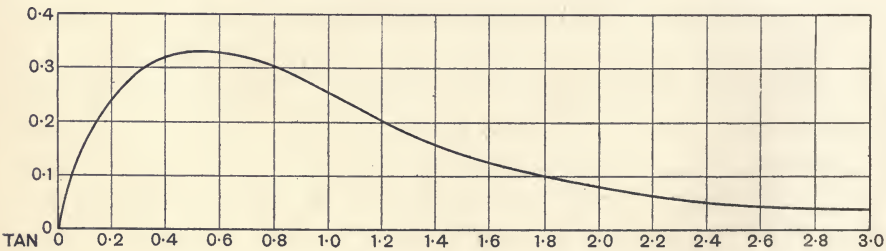

FIG. 16.—DISTRIBUTION OF ILLUMINATION FROM A VERTICAL FILAMENT.

the candle-power had been AC, the illumination at E would have been proportional to $\cos^3 \theta$, but it is reduced in proportion to $\sin \theta$. Let $AB = 1$ and $BE = 1.4$, then the illumination at E is proportional to $\cos^3 \theta \sin \theta = 0.16$. Fig. 16 gives the illumination curve calculated in this way. The horizontal

scale gives the tangents, the vertical scale the illumination plotted to twice the scale of the other illumination curves.

In practice a good deal of light is emitted in the direction of the axis of an electric glow-lamp, and in street lighting the reflector helps to fill up the dark space below the lamp, producing an excellent distribution of illumination.

General Cases of Distribution.—Thus far the theoretical treatment has been confined to the distribution of illumination on a horizontal plane. Whether it is the best or, indeed, an intelligent way to consider practical cases of illumination, has been the subject of no little controversy. When the practical modes of measurement are discussed in a later chapter, something more will be said about the matter, but it is obvious that for the elementary consideration of distribution of illumination, it is better to take the most simple cases first.

For interiors of large buildings such as railway stations the illumination of walls is quite as important as the illumination of the ground; and in the open street any one who wishes to consult his watch will not hold it horizontally, but with the face turned towards the light. In a railway goods-yard the illumination on the ground is practically of no consequence, but the lighting of the sides of the wagons is very desirable. In a station the good lighting of time-tables is no less important. No general rule can be laid down, but for ordinary street work it appears to be best to aim at a fair illumination of the ground, this being the most difficult. Practical measurement may conveniently be made at a height of 4 feet from the ground, but this will be discussed later.

For any source of light, and at any given distance from that source, and with a screen which may be turned at any angle, the illumination of the screen will be greatest when it is turned full to the light, so that the light falls perpendicularly on it. The illumination is then inversely as the square of the distance, or, according to the convention assumed (the height of the source being unity), as the square of the cosine of the inclination of the ray to the vertical. The curve of cosine squared is given in Fig. 17.

The illumination of the vertical plane, the height of which is small compared with the height of the lamp,—for example, the side of a truck in a goods-yard lighted by high lamps,—is proportional to the product of the sine of the angle of incidence into the square of the cosine. This curve is given in Fig. 17. It will be noticed that it is zero below the lamp, and at 45 degrees is equal to the illumination on a horizontal plane. In other words, the illumination on the top and on the side of a small cube placed on the ground at this position would be the same. At greater distances the curve continually approaches the curve of the squared cosine. The illumination on the wall of a house facing a lamp, and at a distance measured by the

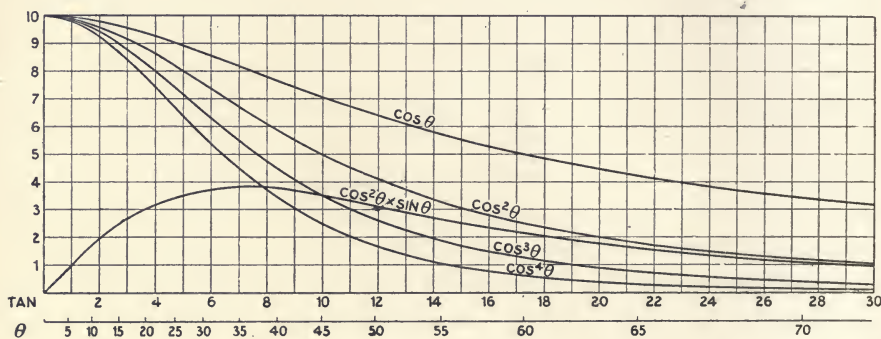

FIG. 17.

angle of incidence of a ray striking its foot, follows the square of the cosine on that part which is level with the light (that is, inversely as the square of the distance), and falls off to the product of the sine into the square of the cosine at the foot of the wall.*

Precisely the same law is followed in the variation of the illumination at a given point, when a lamp in the neighbourhood is placed at different heights in a perpendicular line. This is

* Since Chapter XII. contains no reference to cases of purely horizontal illumination, it may as well be recorded here that such cases exist. Passengers on the tops of omnibuses, the audience in the gallery of a theatre, readers consulting books in the upper gallery of a library receive practically horizontal illumination. The sentry at the west entrance to Wellington Barracks enjoys horizontal illumination from the considerable number of lamps in front of Buckingham Palace.

one of the few theorems of illumination which are to be found in text-books. The curve in Fig. 18 is the same as the $\cos^2 \theta \times \sin \theta$ curve of Fig. 17. It represents the illumination at the point A by a source of light placed at different heights in the vertical line BD. This diagram differs from the preceding ones in these articles, since the illumination is here measured along a horizontal scale instead of a vertical. The vertical scale in Fig. 18 represents the variable height of the source of light. When the light is low the illumination at A is feeble, in spite of the proximity of the light, because the angle of incidence is so great. As the light rises this angle is reduced, and the illumination at A increases, until the light reaches the point D. It is then a maximum, and it may be shown that $BA = BD \times \sqrt{2}$, the angle of incidence BDA being $54^\circ 44'$. It will be observed that a small change in the height BD may be made without appreciably altering the illumination at A. If the height be increased, the illumination will be diminished, owing to the increased distance.*

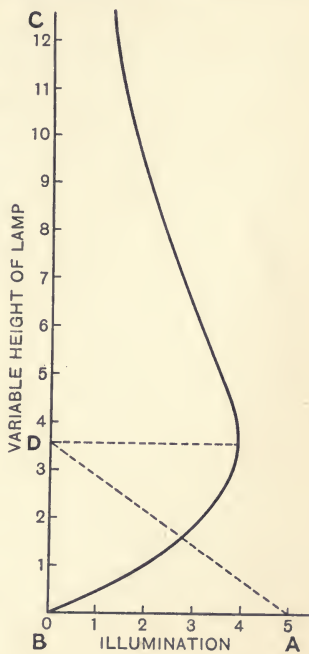

FIG. 18.

Distribution of Illumination on a Plane by Lamps at Varying Heights.— In Fig. 19 the vertical scale gives the illumination on a horizontal plane; the horizontal scale is a scale of feet. The curve starting from 1 is the ordinary curve of the cubed cosine for a lamp 10 feet from the ground. Raising the lamp $\sqrt{2}$ to 14.14 feet diminishes the maximum illumination to one-half, and lowering it to $\sqrt{0.5}$, or 7.07 feet, doubles the original maximum, as shown by the curves. The curves intersect and cross. At 30 feet from the point below the lamp the illuminations are as follows :—

* It may be remarked that the $\cos^2 \theta \times \sin \theta$ curve is the slope or differential of the $\cos^3 \theta$ curve, the maximum ordinate occurring at the point of inflection, when $3 \cos^2 \theta = 1$.

Height . . .	7.07	10	14.14
Illumination . . .	0.236	0.0316	0.0388

Fig. 20 shows the illumination received on a surface always arranged directly facing the lamp; it is inversely proportional to the square of the slant distance. The curve marked $H = 0$ is a curve of inverse squares. The relation between the curves in Fig. 19 and Fig. 20 is of interest in connection with the

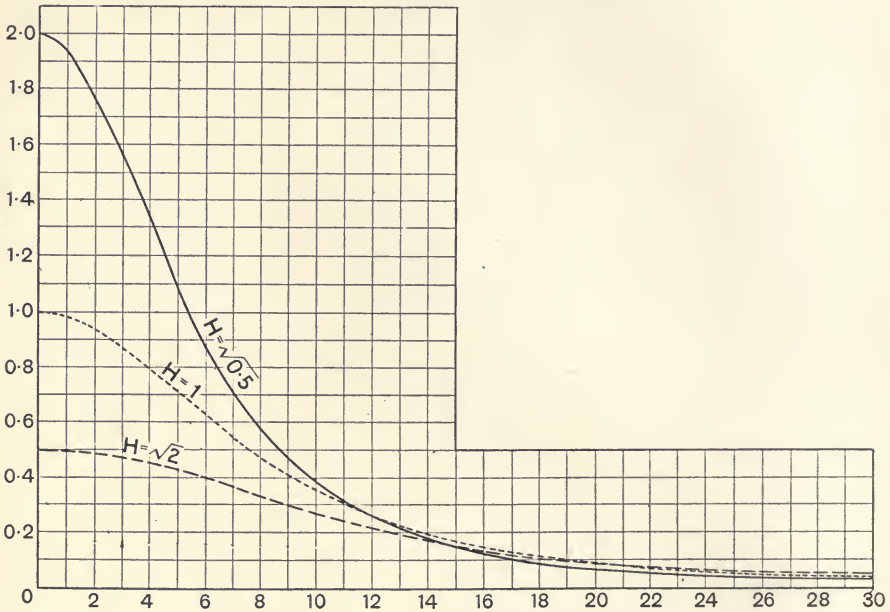

FIG. 19.

question whether the screen of an illumination photometer should be horizontal or should face the light.

Relation between Height and Spacing of Lamps.—If the lighting of a street is to be defined by the minimum illumination, without reference to the number of lamps, their height, or their distance apart, a wide choice is left to the engineer who has to decide these quantities. If all illumination of a greater degree than the minimum is to be regarded as waste from the contractor's point of view, his first aim would be in the direction of uniform illumination. Reference to the illumina-

tion curves in Fig. 10 shows that when lamps are spaced along a line at a distance apart equal to their height from the ground, the maximum illumination exceeds the minimum by only $2\frac{1}{2}$ per cent. Adopting this spacing, at what height and distance should lamps be placed, and what should be the candle-power in order that the minimum illumination along the line shall be 0.1 foot-candle? The minimum has been shown to be 1.93

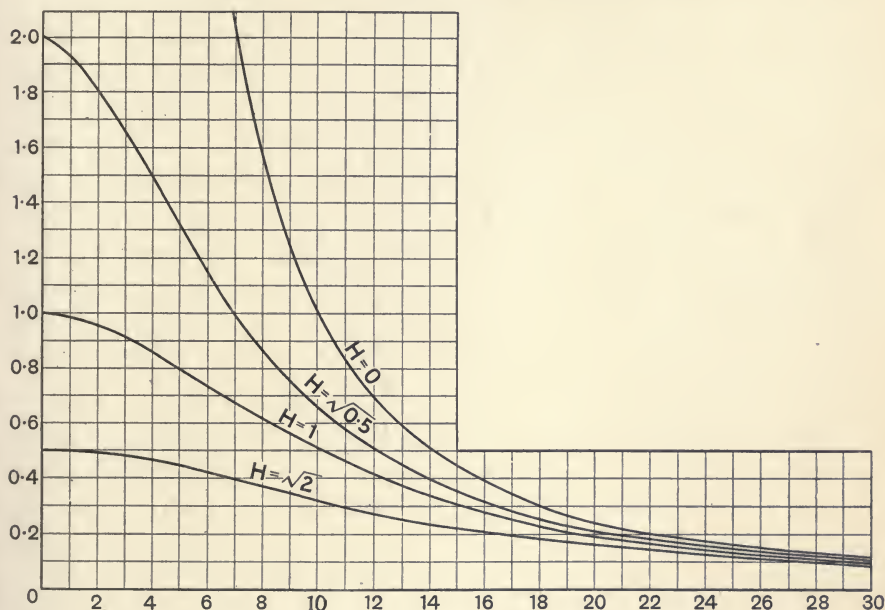

FIG. 20.

of the illumination which would be found below a single lamp if the light was emitted uniformly, and if there were no shadow. Taking the absurd extreme case of lamps one foot high and one foot apart, each need be only 0.521 or about $\frac{1}{2}$ candle-power. With lamps 10 feet apart and 10 feet high, the candle-power of each must be 52.1, and with lamps 40 feet high and 40 feet apart 840, and 80 feet high, 3340 candle-power. But it is not reasonable to consider the lighting along a line. The higher the lamps, the wider the strip of ground which is lighted. It will be found that the candle-power per

1000 square feet is the same in each of these three cases. The uniform illumination is gained at the expense of a large number of lamps. A little consideration shows that it is worth while to make a present to the public of some illumination over and above the minimum, for the sake of spending less on lamp-posts. Spacing lamps at a distance apart equal to six times their height (Fig. 13) is going a little too far, perhaps, in the other direction. Beginning with the extreme case again, of lamps one foot high and 6 feet apart, the candle-power of each must be 1.59 in order to obtain a minimum of one-tenth of a foot-candle. Lamps of 159 candle-power at 10 feet from the ground and 60 feet apart, or lamps of 2540 candle-power, 40 feet high and 240 feet apart, give the same minimum, and 10,200 candle-power for 80 feet high. The maximum below the lamp, assuming uniform emission and no shadow, is about sixteen times the minimum; the candle-power per 1000 square feet is about three times greater than when the lamps were spaced at a distance apart equal to their height.

In 1881, part of the City of London was experimentally lighted by Messrs. Siemens Bros. & Co. Six arc lamps taking about 30 amperes continuous current were placed on poles 80 feet high, and about fifty others taking 12 amperes alternating current, on poles 20 feet high. In each case the spacing was designed in accordance with the principle discussed on page 37. The principle is, that the illumination at a point on a horizontal plane at a given distance from the point below the lamp is a maximum when the ratio of that distance to the height of the lamp is as $\sqrt{2}$ is to 1. As nearly as circumstances would permit the lamps were therefore placed at a distance apart equal to 2.83 times their height above the ground. It was assumed that the candle-power was the same in all directions, which was far from the case; but the settling of the distances by calculation at this early date is interesting.

The Spacing of Street Lamps.—When lamps are spaced at a distance apart less than three times their height, the illumination due to several lamps overlaps. When the distance is about three times or more than three times their height, the

light from the more remote lamps may be neglected and the calculation becomes simplified. When the distance is more than ten times the height of the lamp, it is useless to consider the minimum illumination on the ground either by calculation or by measurement. Street lighting carried out by widely spaced lamps of such candle-power that the illumination on the ground is less than one-hundredth of a foot-candle (say, one-tenth lux) may be called beacon lighting. The chief use of the lamps is to mark out the roads, and only a small area near each lamp can be said to be illuminated. In such a street one can see carriages as dark masses of shadow rather than as illuminated objects. On a wet night one can see them better because the black masses show up against the reflecting puddles.

The calculation of the minimum illumination at the midway point between two lamps is sufficient for many purposes. For a required minimum illumination $2E$ (half being contributed by each lamp)

$$E = \frac{\text{c.p.} \times \cos^3 \theta}{H^2},$$

and with a given candle-power c.p.

$$\text{c.p.} = \frac{EH^2}{\cos^3 \theta},$$

where H is the height of the lamp, and θ the angle of incidence of the light at the midway point. Half of the distance between the lamps divided by the height of a lamp gives the tangent of the angle, and the cube of the cosine can be found at once from the table given in the Appendix.

It is, however, sufficient in many cases to substitute the cotangent for the cosine. The difference in the case of tangent $\theta = 3$, or lamps spaced at a distance apart equal to six times their height, is 5.3 per cent; for tangent $\theta = 4$, 3.05 per cent; and for tangent $\theta = 6$, 1.35 per cent, the cotangent being greater than the cosine. The formulæ then become:—

$$E = \frac{\text{c.p.} \times (H/D)^3}{H^2} \qquad \text{c.p.} = \frac{EH^2}{(H/D)^3}$$

D being half the distance between the lamps.

These formulæ may be used for settling the candle-power of lamps to be used on existing lamp-posts.

The following table gives the candle-powers required to produce an illumination of 0.1 foot-candle at a point on the ground midway between two lamps, at height H in feet and distance apart $2D$:—

D/H.	H = 1.	H = 10.	H = 15.	H = 20.
1.5	0.282	28.2	65.8	117
2	0.56	56	126	224
3	1.58	158	356	633
4	3.52	352	792	1409
5	6.65	665	1496	2660

The candle-powers were calculated by the formula $c.p. = EH^2/\cos^3 \theta$. For example, let $H = 15$ and $E = 0.05$, being half of the required minimum illumination. $EH^2 = 11.25$. Let the distance apart be 90 feet, $D/H = 3$. From the table in the Appendix it is found that the cube of the cosine of the angle whose tangent is 3, is 0.0316. Divide 11.25 by 0.0316 and the result is 356.

Inspection of this table shows that lamps of 356 candle-power on posts 15 feet high and 90 feet apart give the same minimum as lamps of 352 candle-power on posts 10 feet high and 80 feet apart. This suggests that for any given candle-power, and for a given minimum illumination, there is a simple relation between the height and the distance apart.

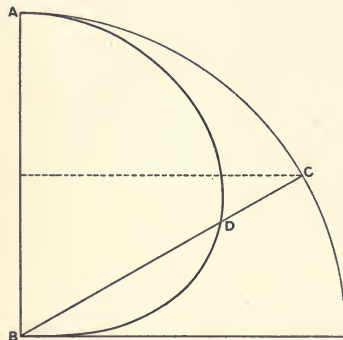

FIG. 21.

Let a lamp at A, Fig. 21, with a uniform candle-power in all directions, give a certain illumination on the horizontal plane at B. Move the lamp to C and let $\cos \angle ABC$ be 0.5.

The illumination at B will be reduced to half. Now move the lamp along the radius CB to D. BD is $1/\sqrt{2}$, or 0.707 of BC . The illumination at B will be restored to its original value. But 0.707 is $\sqrt{\cos \theta}$. The curve Fig. 21 is easily

calculated from this, and is the locus of a lamp giving constant illumination at a point on the horizontal plane. In ordinary mathematical language

$$r^2 = \frac{c}{E} \cos \theta,$$

where c is the candle-power and E the illumination.

If a lamp at A , Fig. 22, on a post having a height AB , gives a certain illumination at the point O , the same lamp moved to C on the post CD will give the same illumination at O . If the lamp is raised to E or F the illumination at O is the same; the maximum illumination is very much less. Near the point H the height may be altered considerably without altering the illumination at O materially. OG is $\sqrt{2}$ times GH (see Fig. 18).

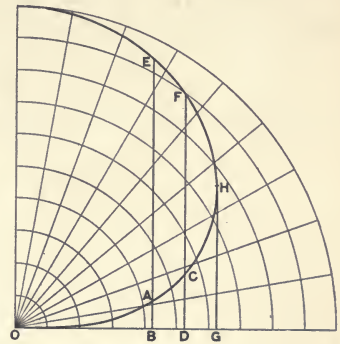

FIG. 22.

Fig. 22 shows that with a given candle-power and a given minimum illumination on the ground, the lamps may be spaced at a distance apart not greater than $OG \times 2$. It is for the engineer to consider in any particular case whether the expense of so tall a post as H is warranted, or whether a larger number of posts of height DC would be less expensive.

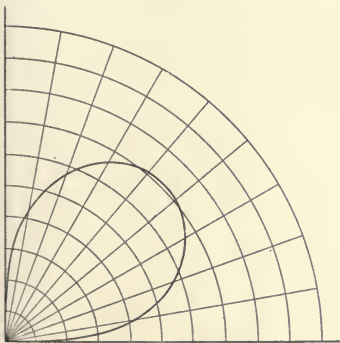

FIG. 23.

If, instead of giving uniform candle-power in all directions, the source of light is a vertical filament, the radius is reduced in proportion to $\sin \theta$ and the curve takes the form shown in Fig. 23.*

It has been already observed that the candle-power of

* Let O be the point on the ground, let the filament be at L , let $OL=r$, and let θ be the angle which OL makes with the vertical. Then if c be the candle-power of the lamp, the

metal filament lamps does not closely follow the theoretical distribution. In applying this principle to the spacing of such lamps, it is necessary to consider the actual candle-power in directions in the neighbourhood of the minimum, the effect of any reflector or shade being included.

illumination of a surface at O normal to OL is $\frac{c \sin \theta}{r^2}$, and on the ground at O it is

$\frac{c \sin \theta \cos \theta}{r^2}$, which gives the locus of L.

$$\frac{c \sin \theta \cos \theta}{r^2} = E$$

$$r^2 = \frac{c}{E} \sin \theta \cos \theta$$

$$r^2 = \frac{c}{2E} \sin 2\theta.$$

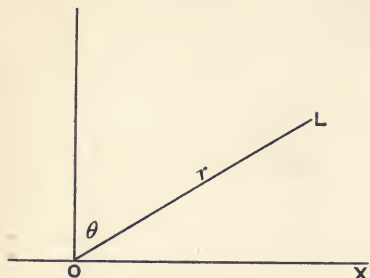

FIG. 24.

The curve is the lemniscate of Bernoulli, and its complete shape is a figure of 8. Tangents at the origin are the horizontal and vertical there. The maxim value is when $\theta = 45^\circ$, the line about which the curve is symmetrical.

CHAPTER IV

DISTRIBUTION OF ILLUMINATION OVER A PLANE

The Construction of Contours.—The foregoing considerations relate only to the distribution of illumination along a straight line, and the typical curves (Figs. 10 to 14) show the results only in the line of the lamps. The next step is to consider the general distribution in plan. For this purpose lines or contours of equal illumination may be calculated. These correspond to the contour lines on maps, which show equal elevations. The calculation of these contours has been supposed to be laborious and intricate. There are generally difficult and tedious ways of performing any calculation, and certain people will delight in them. The following curves (Figs. 27 to 35) were drawn with no geometrical or even arithmetical calculations. A number of circles having as radii the tangents of the angles of which the cubes of the cosines are round numbers taken from Table I., were drawn with thick black lines. The lengths of the radii are the lengths of the horizontal lines in Fig. 9 intercepted between the curve and the zero ordinate, or the last vertical line on the left.

One set was drawn on ordinary paper and another on tracing paper. Each circle was boldly numbered along a radius, with a maximum at the centre, 100. One sheet was laid over the other, and was adjusted, with the centres, that is the lamps, at the required distance apart, remembering that tangent 1 is equal to the height of the lamp above the ground, and a blank sheet of tracing paper was laid over all.

Fig. 25 shows, for the sake of clearness, portions only of two sets of circles. The lamps are at a distance apart equal

to four times the height of each. The tangent of the angle of incidence at the point midway between the lamps is 2. The angle of incidence is 63 degrees 27 minutes, and the cube of the cosine is 0.0893. The intersections of the circles give a number of quadrilateral figures. Lines are drawn by free-hand from corner to corner through these quadrilaterals, and these are the contours required. Everywhere along the circle numbered 6 the illumination due to each lamp separately is 0.06 of the maximum illumination below the lamp. At the point when the two 6 circles cross the illumination will evidently be 12; and where circle 8 crosses circle 4 the illumination

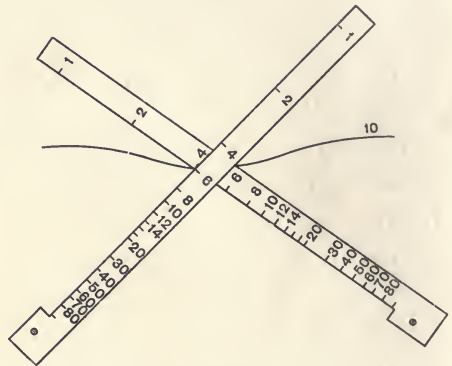
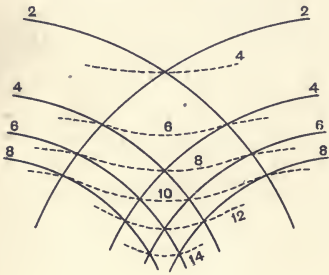

FIG. 25.

FIG. 26.

will be 12. Thus the values of the contours can be found. Where the circles do not intersect a little judgment is required, and this may be assisted by the following method.

Mark off two scales of radii along the edges of two strips of paper and pin them on to a sheet at points representing the lamps at the desired distance apart, as in Fig. 26, starting, say, with 6 set against 4, make a dot at the intersection. Move one strip clockwise and the other counter-clockwise until the next pair of divisions 8 and 2 meet, make another dot, and continue, observing from time to time that the sum of the numbers remains constant. Only one quarter of the whole system need be drawn when two lamps are concerned, and this can be repeated four times by tracing. It is, in general, better

to find the contours of two lamps first, and to combine a third by the first method. The contours for three lamps may be found by using three strips, but a good deal of mental arithmetic is needed to adjust them so that the sum may be constant. The illumination of a number of points regularly spaced or otherwise may be found by using three or four or more radial strips, and these may be prepared to represent lamps of different candle-power or placed at different heights. The strips are adjusted to intersect at any desired point, and

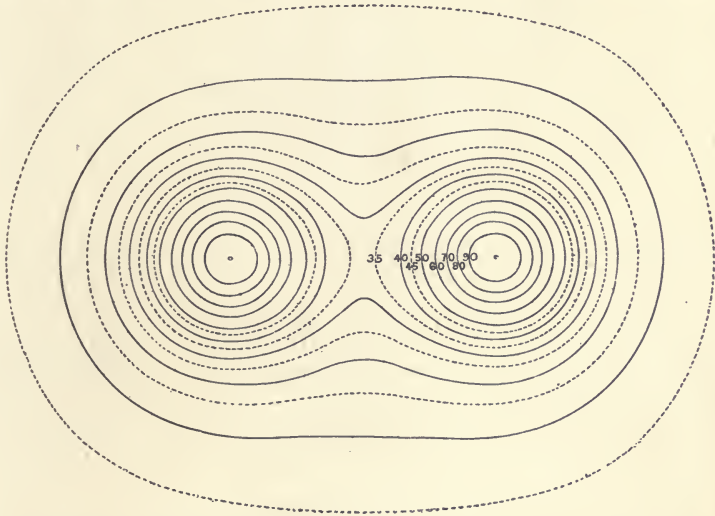

FIG. 27.—CONTOUR LINES OF EQUAL ILLUMINATION OR ISO-LUX CURVES, DUE TO TWO LIGHTS AT A DISTANCE APART EQUAL TO THREE TIMES THEIR HEIGHT.

the readings on the scales at this point are added together and written against the point. Contours may then be drawn by hand and eye, as in ordinary map-work, and at any doubtful point the contour may be easily verified by bringing the scales to intersect.

Contours or Iso-lux Curves.—Fig. 27 gives the contours for two lamps at a distance apart equal to three times their height. The maximum illumination due to each lamp is 100. The smallest curves, which are indistinguishable from circles, represent an illumination of 90. The resultant maximum is 103.16.

Fig. 28 refers to two lamps at a distance apart equal to four times their height. The smallest curve is 90 and the maximum is 101.4.

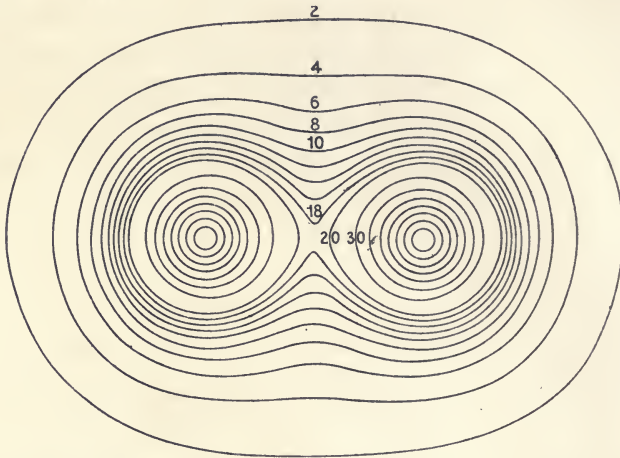

FIG. 28.—CONTOUR LINES OF EQUAL ILLUMINATION OR ISO-LUX CURVES, DUE TO TWO LIGHTS AT A DISTANCE APART EQUAL TO FOUR TIMES THEIR HEIGHT.

Fig. 29 gives the contours for three lamps in zig-zag, being the contours of Fig. 28 compounded by the tracing-paper method with those of a third lamp.

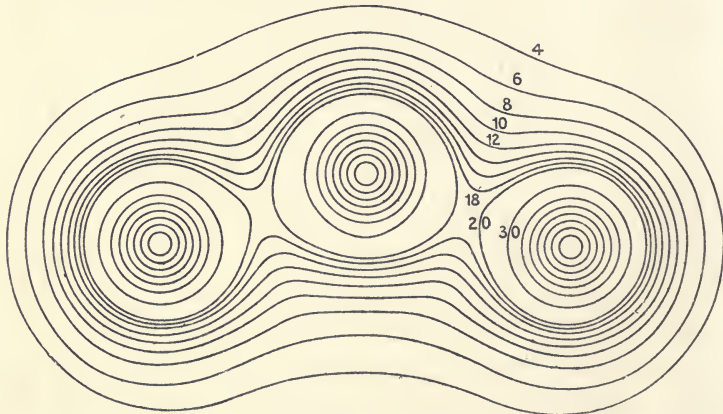

FIG. 29.—CONTOURS OR ISO-LUX CURVES FOR THREE LIGHTS. DERIVED FROM FIG. 28.

If these contours be considered to represent a solid figure, a vertical section gives curves of the kind shown in Figs. 10-13.

The lowest of the full-line curves in Fig. 12 represented a vertical section along the middle line of Fig. 27.

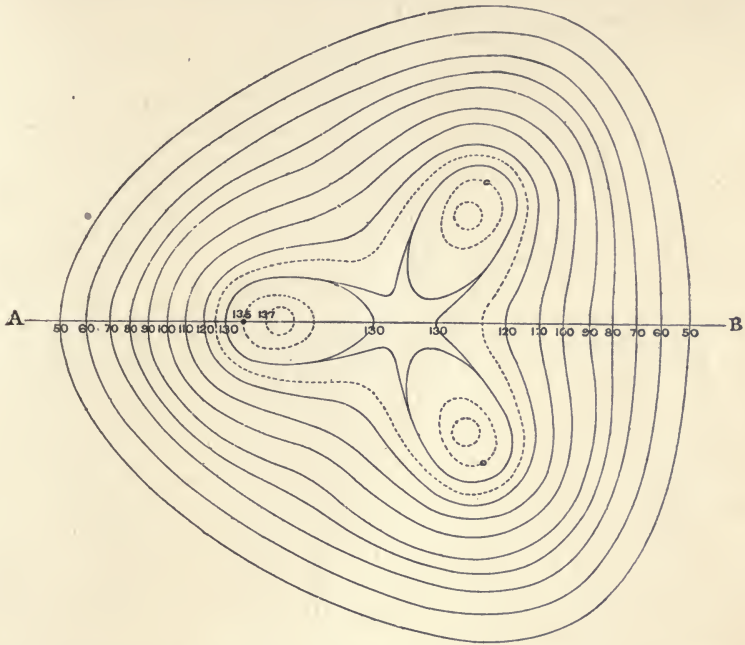

FIG. 30.—CONTOURS OR ISO-LUX CURVES DUE TO THREE LIGHTS AT DISTANCES APART EQUAL TO ONE AND A HALF TIMES THEIR HEIGHT.

The contour lines for three lamps, placed at the corners of

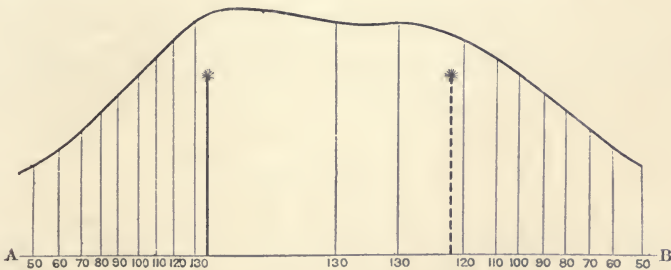

FIG. 31.—ILLUMINATION CURVE DUE TO THREE LIGHTS AT DISTANCES APART EQUAL TO ONE AND A HALF TIMES THEIR HEIGHT, BEING A SECTION OF FIG. 30 THROUGH THE LINE AB.

an equilateral triangle, the side of which is 1.5 the height of the lamp above the ground, are given in Fig. 30. Treating this

as a solid figure, Fig. 31, a curve of the same kind as Figs. 10 to 13, is a section of it through the line AB. It is to be

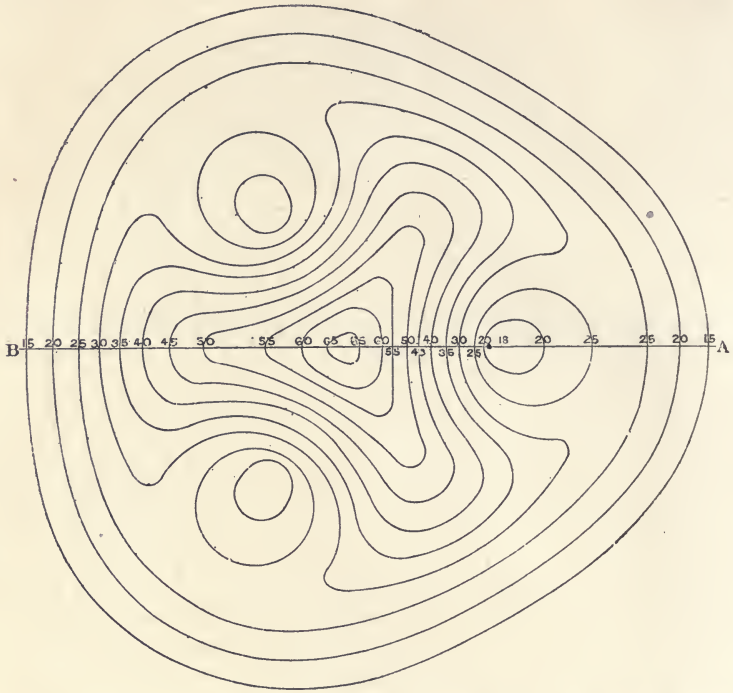

FIG. 32.—CONTOURS OR ISO-LUX CURVES DUE TO THREE ARC LAMPS AT DISTANCES APART EQUAL TO ONE AND A HALF TIMES THEIR HEIGHT.

noticed that the points of maxima are not under the lamps, and that within the triangle the light does not vary more than 10

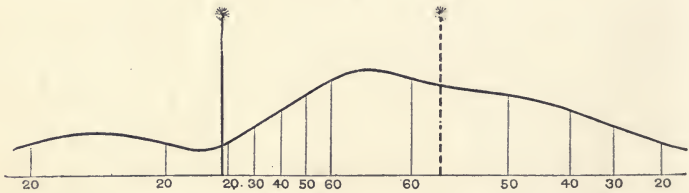

FIG. 33.—ILLUMINATION CURVE ALONG THE LINE AB, FIG. 32.

per cent. In most cases of street lighting the contours are little else but circles; the other curves are negligible, since

they would refer to differences of illumination which are too small to be of any practical importance.

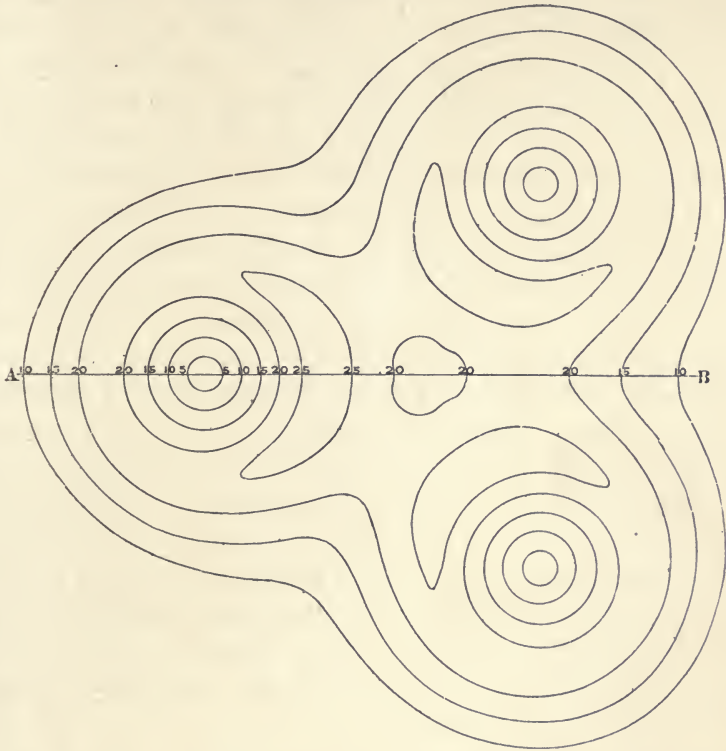

FIG. 34.—CONTOURS OR ISO-LUX CURVES DUE TO THREE ARC LAMPS AT DISTANCES APART EQUAL TO THREE TIMES THEIR HEIGHT.

With ordinary arc lamps in clear glass lanterns or globes the contour lines present a very different character, owing to

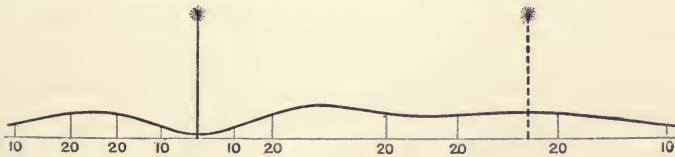

FIG. 35.—ILLUMINATION CURVE ALONG THE LINE AB, FIG. 34.

the peculiar distribution of the light. The contour lines in Figs. 32 and 34 have been constructed on the assumption

that the light is distributed as shown in Fig. 14. Fig. 32 represents the illumination due to three arc lamps at a distance apart equal to 1.5 of their height. Fig. 33 represents a section through Fig. 32. Fig. 34 shows the contour lines for three arc lamps placed at a distance apart equal to three times their height; and Fig. 35 is a section through $A\hat{B}$, Fig. 34. The values given for the illumination at each contour are arbitrary, but do not differ much from the values given in Fig. 14.

With modern flame arcs, or with diffusing globes or lanterns, the distribution would, of course, resemble Fig. 9 rather than Fig. 14.

It is not suggested that the construction of these contour lines should often be carried out, and no great importance is attached to them. The study of a few typical cases is interesting. Many such curves may be found in Maréchal's book, *L'Éclairage à Paris*. Blondel and Uppenborn have produced others, some of them being highly complicated.

Bases of Comparison of Cases of Illumination.—There is a tendency in many branches of knowledge to attempt to express a very complex quantity by a single figure of merit; but this is often done at the sacrifice of lucidity, and with the loss of anything that can be called description. The horse-power of a steam-engine carries no idea of its weight or the number of revolutions, if any, per minute; the tonnage of a ship tells nothing about its shape or suitability for blue water. The figure of merit of a galvanometer may seriously mislead one who is choosing an instrument, and the mean hemispherical candle-power of an arc lamp is almost as vague as any of the other examples.

Various suggestions have been made for a basis of comparison of different cases of illumination; for example, of two streets, one lighted by gas and the other by electric light. The eye is the ultimate judge. No amount of theorising can establish any better criterion, and if any rules, formulæ, or curves can be found to express the degree and the distribution of illumination, those will be best which agree best with the

opinion of a common-sense critic. Some writers have suggested that the minimum illumination is all that matters, and the rest may take care of itself. Others have argued that the mean illumination is the best measure. Others have proposed that the practical measure of the efficiency of lighting is given by the difference between the brightest and the dimmest parts of the illuminated area.

A curious unit, called a "candle-foot-yard," has been used. It is intended to express the average illumination over an area. A number of measurements were made along a street, from lamp to lamp; an illumination curve was plotted; and the "total effective illumination" was said to be the mean illumination as deduced from the average height of the curves, multiplied by the length of the street along which the measurements were taken. Though the comparison of a number of different cases reduced to this unit affords some useful comparison between the different lamps, and may justify comparisons of costs based on these measurements, a little reflection will show that such a method cannot describe the illumination of the street. It is true only for an indefinitely narrow strip along the line of measurements, and if this is the line of the lamps, the true average is considerably lower than the value thus found.

It has been suggested that the term "luminous flux per unit area" ought to be used instead of "illumination" in certain mathematical considerations,* but in general, for the practical engineering point of view, the more the ideas of flux and 4π are suppressed the better. In considering the average illumination over an area, the idea of flux cannot be avoided; but it is not necessary to use difficult mathematics. The curve in Fig. 36 is the duplication of Fig. 9. It represents the illumination due to a lamp emitting light uniformly in all directions. All that goes above the horizon, that is, one-half, is lost; the other half falls on the ground at a greater or less distance. The total flux of light emitted in all directions by a radiant point is 4π

* E. P. Hyde on *Geometrical Theory of Radiating Surfaces*, Bureau of Standards, America, *Bulletin* 3; also *Science Abstracts*, 1148, 1907.

(see p. 22), and the useful flux emitted and received on an indefinitely extended horizontal plane is one-half of this, or 2π .*

The figure of revolution of the curve—in other words, the hill of which Fig. 36 is a section—has a solid volume of 2π . Its height over any point on the plane is a measure of the illumination at that point.

Consider it as a hill of sand on a floor of infinite extent. The layer of sand becomes thinner and thinner, theoretically never diminishing to nothing. As the hill theoretically extends over an infinite number of square feet, the average weight per square foot is infinitely small. In order to obtain any appreciable average, a limited area must be chosen. The problem is: a circle of a given radius being described about the axis of this hill, to determine the average height over that circle, or, in other words, the height of a cylinder having that circle as a

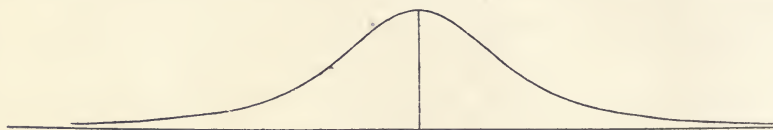

FIG. 36.

base, and having a solid content equal to that part of the hill which is within the circle.

Imagine the source of light to be at the centre of a globe partly transparent and partly opaque. Let the transparent portion be just large enough to allow light to pass to illuminate the given circle, and let the opaque part cut off all the rest. Then the area of the transparent part of the globe is a measure of the solid angle, and this measures the flux or total light.

This solid angle may be expressed trigonometrically, and

* The equation of this curve is $y^2 = \left(\frac{1}{1+x^2} \right)^{\frac{3}{2}}$, taking the foot of the lamp-post as the origin. It may be shown by integral calculus that the solid contents of this curve about its vertical axis is 2π . See Trotter on "A Dioptric System of Uniform Distribution of Light," *Proc. Inst. Civ. Engs.*, 1883, lxxviii. 335.

In 1732, M. Kurdwanowski, *Gentilhomme Polonois, Capitaine dans le Regiment Saxe*, contributed a memoir to the Académie des Sciences, Paris. The memoir was not published, but an abstract is given in the *Histoire* for that year, p. 95. He seems to have described an illumination curve, but no mathematical description or diagram is given.

the calculations may be carried out by integral calculus; but though these are rapid they are not necessary. The matter may be treated more intelligibly for most people by Archimedes' theorem. Let $ABPCD$, Fig. 37, be half of a sphere of unit radius, and $AEDF$ a circumscribing cylinder. Let OP be the axis common to the sphere and to the cylinder, and let $GLBCKH$ be a plane perpendicular to the axis, cutting the sphere at B and C and cutting the cylinder at K and L . Archimedes found that the surface of the half-sphere and of the curved surface of the cylinder are equal, and are 2π ; that the spherical surface BPC is equal to the cylindrical surface $LEKF$, and the spherical surface $ABCD$ is equal to the cylindrical surface $ALDK$.

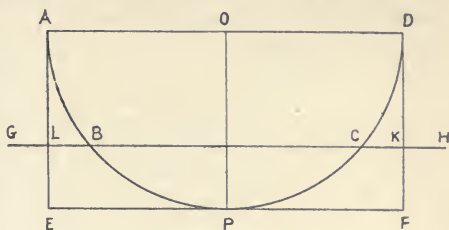

FIG. 37.

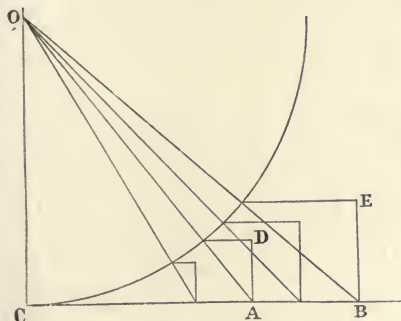

FIG. 38.

A quadrant of a sphere of unit radius being drawn (Fig. 38), let OA and OB be rays falling on the plane at the points A and B . Erect perpendiculars at D and E . The lengths AD and BE represent the flux falling within the cones swept out by OA and OB . They also are a measure of the solid angle.*

By this construction, a number of points such as D and E may be obtained, and thus the curve, Fig. 40, may be constructed. The vertical scale on the right gives

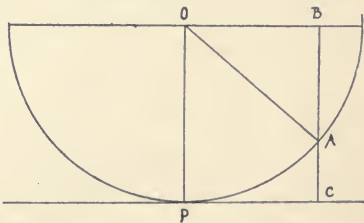

FIG. 39.

* The trigonometrical treatment is as follows: Let OA be a ray falling on the sphere at A . Through A draw the perpendicular BAC . Then AC measures the solid angle, since it is equal to the height KF (Fig. 37) of the cylinder. Let θ be the angle POA , then the ratio

the flux or solid contents. At an angle of incidence of 60 degrees, that is to say, a circle subtending 120 degrees, one quarter of the total flux of 4π is received, or one-half of that which is emitted in one hemisphere.

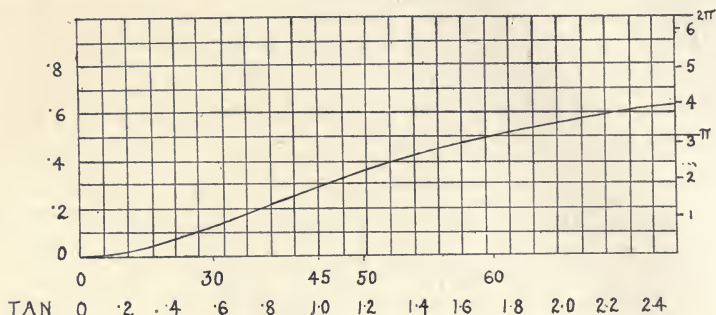

FIG. 40.—CURVE OF FLUX.

In the explanation of the illumination of inclined surfaces (p. 19) Fig. 6 represented a beam passing through a hole one foot square, and it was shown that as the screen was tilted, the illuminated area increased and the illumination decreased. In that elementary treatment it was desirable to keep the idea of flux in the background, but we may now regard illumination as the flux divided by area. In the Geneva units the lux is equal to the lumens per square metre.

We can now deal with the problem, first arithmetically, and afterwards graphically. Taking a case from Table I. in the

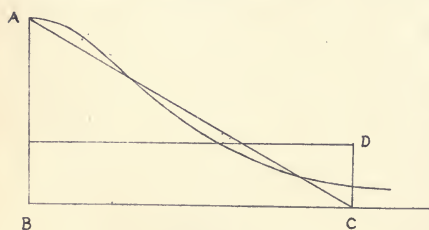

FIG. 41.

Appendix, let AB (Fig. 41) be unity, and the radius BC be 1.702. This is the case when the angle θ is 59 degrees 34 minutes ($\tan 59$ degrees 34 minutes = 1.702). $\cos \theta$ is found in the table to be 0.507.

Then $1 - \cos \theta = 0.493$, and

$2\pi \times 0.493 = 3.1$. This is the solid content of the hill within the

BA to OP is cosine θ , OP being unity. Then AC is $1 - \cos \theta$. The circumference of the cylinder being 2π , the surface LEKF (Fig. 37) is $2\pi (1 - \cos \theta)$. This is the ordinary trigonometrical expression for a solid angle.

circle. The area of the circle is $\pi \times 1.702^2 = 9.11$. The height of the cylinder having a base 9.11 square units, and a solid content of 3.1, is $3.1 \div 9.1 = 0.341$. The maximum illumination being 1, and the minimum being 0.13, the mean is 0.341. The mean height of the section in Fig. 41 is 0.507, which is a very different matter, being about 65 per cent higher than the true mean. It may be observed that the mean height of all the ordinates of the cosine cubed curve up to any point is the cosine at that point.

In Fig. 42 the same problem is solved graphically. Let AB be the height of the source of light, and be numerically

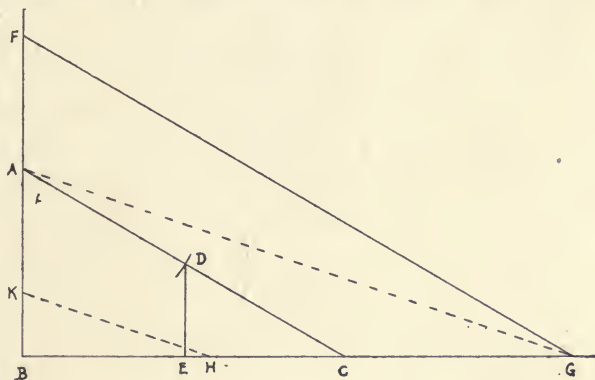

FIG. 42.

equal to unity, and let BC be the radius of the circle. In AC cut off AD, making AD equal to AB. Drop the perpendicular DE, then DE is $1 - \cos \theta$. Make BF in BA produced equal to BC; draw FG parallel to AC. Then (AB being 1) $1 : BC :: FB : BG$; therefore $BG = BC^2$. In BG cut off BH equal to twice DE. Then $BH = 2(1 - \cos \theta)$. Join GA, and through H draw HK parallel to GA. Then $GA : 1 :: HK : KB$. Therefore $KB = 2(1 - \cos \theta) / BG$. It will be seen that KB (Fig. 42) is equal to DC (Fig. 41).

Although this calculation of the mean illumination can be easily carried out by means of the tables and a slide-rule, or, in the absence of tables, by the graphical construction, the simple case of a source of light of uniform candle-power in all directions,

and of a circular area, is not one that is likely to occur in practice. It is introduced here to explain the theoretical principle of a mean illumination.*

Characteristic Curves.—The curves which have been illustrated and discussed are of two kinds. The first, which may be called illumination curves, are, as it were, vertical sections along a route, the ordinate being proportional to the illumination on a horizontal plane at any point, and the abscissa being the horizontal distance of that point from the point below the source of light. With the exception of Fig. 14, the candle-power has been assumed to be uniform in all directions. The second, which are sometimes called iso-lux curves, are contour lines of equal illumination, on a horizontal plane. For the simple case of a street or of an open space lighted by a number of similar and regularly spaced lamps, these curves give a good indication of the amount and of the character of the illumination. It is possible to sum up and express by one curve the general distribution of illumination over an area, taking into account lamps of different candle-power and of unsymmetrical or even irregular disposition. This form of curve, which by analogy with those used in other branches of science and engineering may be called a characteristic curve, is related to the first of the two kinds which have been discussed. But while in the former case, the distribution of illumination along a line, the abscissæ were lengths, the abscissæ of a characteristic curve are areas, the ordinates being, as before, illumination. A characteristic curve of illumination is a diagram which resembles a steam-indicator diagram in several respects, since the co-ordinates are the measures of an intensity and of an extension respectively, and the area of the diagram is the measure of a power. The maximum and minimum illuminations may be read off at a glance; the true mean may be found by taking the mean of the ordinates, like the mean pressure in a steam-indicator diagram; and the shape of the curve, as in the steam

* Mean illumination is discussed mathematically in Palaz's *Treatise on Photometry*, chap. iv. sec. 165.

diagram, shows the quality or regularity of distribution. The departure of the curve from a horizontal line shows the want of uniformity of illumination. The portion of an area illuminated to any given degree may be easily found, just as an indicator diagram shows that portion of the stroke during which the steam-pressure exceeds any given amount. Luminous flux or total light is (1) candle-power \times solid angle, or (2) illumination \times area. The area of this diagram is a measure of power in an optical form. Such diagrams might be used for a number of other statistical purposes, such as the distribution of population.

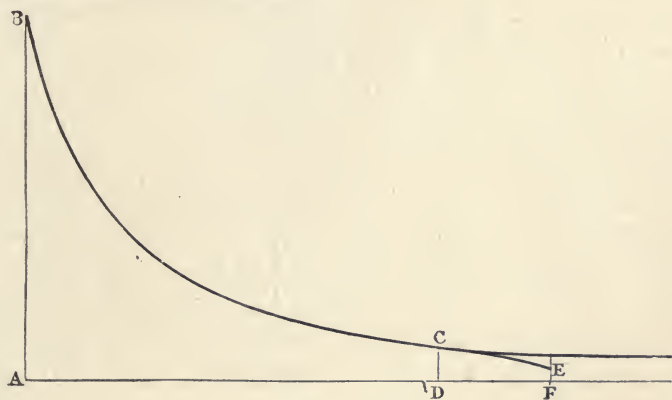

FIG. 43.

Taking the simplest possible case, viz. a single lamp emitting uniformly in all directions light received on a horizontal plane, the illumination curve being of the type shown in Figs. 9 (p. 28) and 36 (p. 54); a minimum illumination or a circle of any given radius being chosen, the characteristic curve may be drawn by plotting areas as abscissæ, and the illumination in foot-candles or lux on those areas as ordinates. From Table I. in the Appendix it is seen that with unit illumination AB (Fig. 43) at the centre of the circle, an illumination of 0.9 is found at radius 0.270, that is, within a circle of area 0.228; an illumination of 0.8, at radius 0.401, or within a circle of area 0.505. Such illuminations and areas give the curve BC, Fig. 43, as far as C, the last ordinate being

0.1, and the abscissa 11.4 being the area of a circle of radius 1.907. This curve differs from the cosine cubed curve, Fig. 9, only in the horizontal scale, the former being the square of the latter, but reduced to a convenient length. The first part of the curve becomes, as it were, shrivelled up, and the flat top seen in Figs. 9 and 35 is imperceptible.*

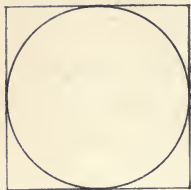

FIG. 44.

If instead of a circular area a square one be chosen, the extremity of the characteristic curve becomes modified. Let a square be circumscribed round the circular area, as in Fig. 44. The parts of the square beyond the circle diminish in illumination, but diminish more rapidly in area as their distance from the centre increases. The limiting illumination is found to be 0.04, and the remainder of the curve has been calculated, and is represented by CE, Fig. 43.

A characteristic curve is an illumination curve with a transformed scale of ordinates. The areas are conveniently represented as percentages on a decimally divided scale. Let BD, Fig. 45, be an illumination curve plotted to any scale on the radius AC. Produce BA to E, making AE any convenient length. Draw CF parallel and equal to AE. Divide AC into any convenient number of equal parts, and CF into the same number of equal parts. Draw radial lines from A to each of the dividing points on CF. For example, AG. Through the corresponding point H in AC draw a perpendicular KH, and produce it to intersect AG. Through the intersection draw a horizontal line cutting AE at L and produce it to M, making ML equal to KH. The curve running through such points as M is the characteristic curve of the illumination curve BD, for a circular area of radius AC.

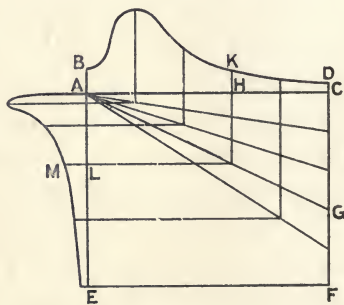

FIG. 45.

* If the base of Fig. 9 is bent to fit a parabola and viewed from a distance, the curve would appear identical with Fig. 43.

The intersections of the radial lines with the perpendiculars lie on a parabola or curve of squares, this being one of the well-known methods of drawing a parabola. Lengths on AE are proportional to π times the squares of corresponding lengths on AC, since AE is a scale of areas of circles, and AC is a scale of radii of those circles. To find the mean ordinate of a curve, the usual procedure is to draw ten ordinates at 5, 15, 25, etc., up to 95 per cent of the length of the base, to add their lengths and divide by 10. These ordinates may be drawn directly on the illumination curve. Let the length of the base or extreme radius of the illumination curve, Fig.

46, be R, then
$$r = \sqrt{\frac{R^2 \times d}{100}}$$

when r is the radius or the abscissa on the illumination curve of an ordinate, and d the percentage of the total area. Thus the 5 per cent ordinate is at 1.34, the 15 per cent ordinate at 2.32, and so on, as in Fig. 46.

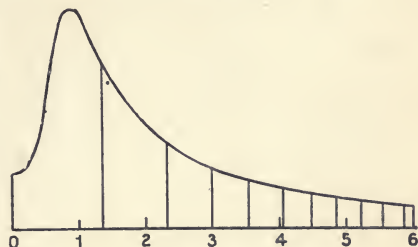

FIG. 46.

To carry out this calculation on a slide-rule, let R be 6, set the 10 on the C scale over 6 on the D scale, and below 5 and 15, etc., on the B scale, find 1.34 and 2.32, etc., on the D scale. This brings out a point of considerable practical interest, that the illumination near the lamp is of very little importance, for it is spread over a very small area.

The characteristic curves in Fig. 47 are derived from the curves in Figs. 10, 11, 12, and 13, both the maximum illumination and the maximum area being reduced to one hundred.

These characteristics do not strictly represent the distribution of illumination over a large area illuminated by lamps in rows, since there are several different ways in which such lamps may be arranged, viz. quadrilaterally, as at the corners of the squares on a chess-board; quincuncially, as at the centres of squares of one colour on a chess-board; or hexagonally, as the cells of a honeycomb. The characteristic of a hexagon differs but little from that of a circle, the lamp in

each case being over the centre. The variations of illumination represented in Fig. 47 are simply those of the resultant curves in Figs. 10 to 13, and the areas are supposed to be circular.

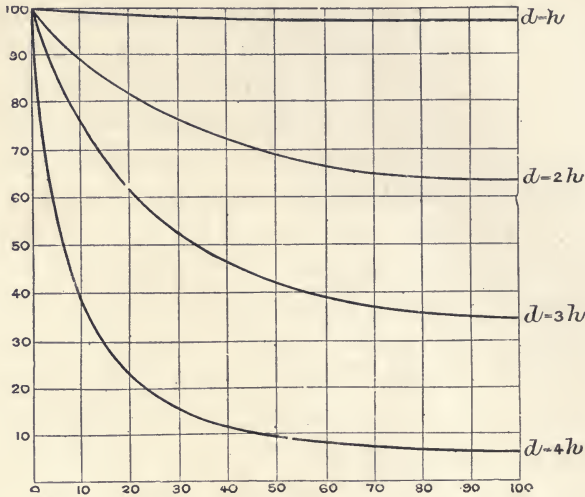

FIG. 47.

Fig. 48 is a portion of Fig. 29 (p. 48), and presents some of the features of lighting by lamps on alternate sides of a street. It differs from a practical case by the closeness of the lamps in proportion to the width of the street, and by the uniform candle-power of the lights in all directions.

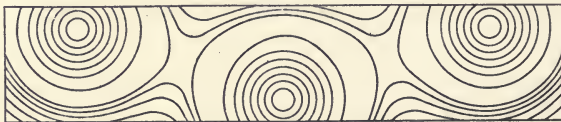

FIG. 48.

This example is, perhaps, more suitable than a practical one for showing the difference between the true mean illumination and the average taken along a line, since the quantities may be easily calculated. The difference is much less than in the case of a single lamp, as already discussed.

Fig. 49 is the illumination curve along the middle of the

street, and Fig. 50 is the curve for a line parallel to this passing through the alternate lamps. The former never reaches the maximum, and the latter is very different from the illumination curve due to two lamps at a distance apart equal to $7\frac{1}{2}$ times their height (see Fig. 13) by reason of the light of the alternate lamp on the other side of the street.

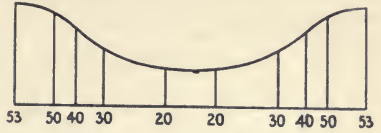

FIG. 49.

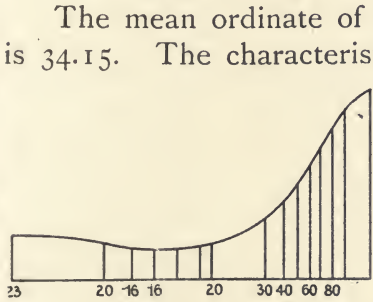

FIG. 50.

The mean ordinate of Fig. 49 is 33; the mean of Fig. 50 is 34.15. The characteristic curve is given in Fig. 51. The areas of each contour were measured and plotted against the illumination. This is necessarily the method of finding the characteristic curve from a set of photometric tests forming a photometric survey of an area.

The mean ordinate of this diagram gives the true mean illumination about 3. As might be expected, the mean taken along a line through the lamps is the highest. The difference would be greater if the lamps were more widely spaced. The droop of the curve towards the minimum appears here as in the portion CE of Fig. 43.

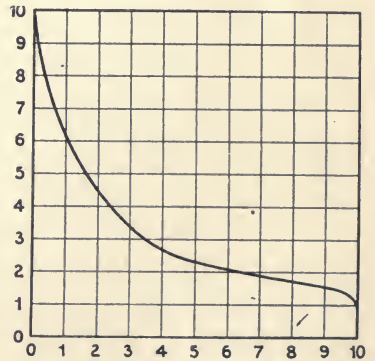

FIG. 51.

Although the calculation of the true mean illumination has been discussed at some length, this quantity must be accepted with caution as a criterion of the useful or practical illumination of any particular case. It is quite possible to have cases which agree closely

in mean illumination, but which may differ largely in useful effect. It is, for example, easy to see that a street may be lighted by powerful lamps widely spaced, while another may be

provided with a large number of small lamps. The two might yield the same mean. In the former case there would be a useless superfluity of light near the lamps and intervals of very low illumination, while the latter would have a more uniform distribution of illumination, only slightly exceeding the mean in some places, and having no very low illumination at all. Let it always be remembered that theory in such cases cannot be allowed to override the common-sense opinion of a man of ordinary intelligence.

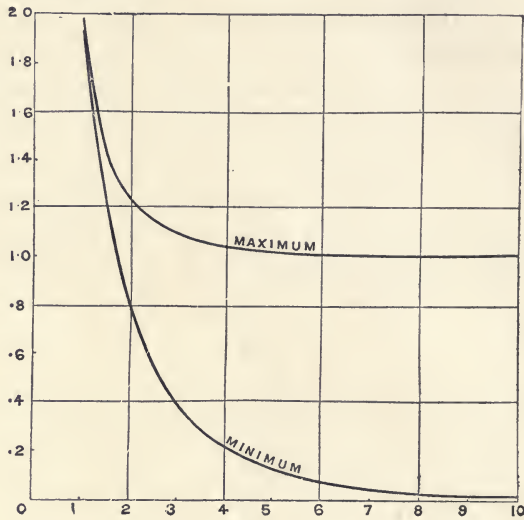

FIG. 52.—CURVES OF MAXIMA AND MINIMA.

Reference has been made to the proposal to consider the difference between the brightest and the dimmest parts of an illuminated area, as a measure of the quality of the distribution (p. 53). This difference is sometimes called the "diversity factor." Many other considerations have to be weighed in determining the best way of carrying out practical cases of lighting, but for what it is worth this difference is represented for the cases shown in Figs. 10, 11, 12, and 13 by the curves of maxima and minima in Fig. 52. The way in which this difference increases with the wider spacing of the lights is worth noticing, but it conveys no useful information as to the area which is illuminated.

CHAPTER V

PHOTOMETERS

Photometry.—Photometry, or the measurement of light and of illumination, differs in several respects from other physical measurements; and before discussing practical apparatus and its use, it is well to give some consideration to the limitations to which photometry is subject. The idea of measuring light is so unfamiliar to many quite intelligent people, that they confuse the word photometry with photography, and have neither the remotest idea that light can be measured nor how any operation of measurement can be carried out when no units of length, volume, weight (for such people do not understand mass in its scientific sense), or time, or appreciable force or movement, enter into the question.

There is an important branch of physical science which deals with the objective action of light. This department of the science of optics is concerned with the generation of luminous radiation, its transmission, refraction, reflection, polarisation, and so on; it deals with dynamic and geometrical considerations, either as pure abstractions, or assisted, illustrated, and guided by experiment.

Pierre Bouguer,* Professeur Royal en Hydrographie, was the first to recognise the conditions and to describe scientifically correct methods of photometry. In the preface to his *Essai d'optique sur la graduation de la lumière*, published in Paris in 1729, he touches on the work of previous writers on optics, and says that this science stands in need of an entirely new

* Bouguer took part in the expedition which Louis XV. sent in 1735 to Peru to measure an arc of meridian; he invented the heliometer.

branch which should have for its object the consideration of the force or vivacity of light. In the first few pages of the book he states the principle of the square of the distance and the method of comparing two lights with each other or against a third.

Photometry, in the original sense of the word, as used by Lambert in his treatise *Photometria sive de Mensura et Gradibus Luminis colorum et umbrae*, published in 1770, was not so much experimental as deductive. Lambert started with such axioms as "Two candles give more light than one," and he developed theorems like Euclid. He used experiments chiefly to illustrate theorems and to verify laws, but he also discovered facts. Many writers have attributed to Lambert the invention of the photometer generally known as Rumford's, but at the beginning of *Photometria* he discussed at some length the desirability for a photometer, and regretted that no such instrument had been invented. Summing up the discussion in a passage in italics,* he said that the eye lacks an instrument analogous to a thermometer. This statement is remarkable, for he describes several experiments in which he actually employed photometric methods.

Photometry in its modern sense is mainly experimental, and the term is hardly applicable to the foregoing chapters of this book, which, with the exception of the description of the standards of light, has been of a deductive character.

Photometry differs from those other sections of optics to which reference has been made in that it depends upon the subjective effect produced by the stimulation of a special organ of sense. Whatever results we obtain, however ingenious the apparatus used to arrive at them, and whatever the conditions we prescribe for carrying out the work, our measurements are of no value if they disagree with the common-sense estimate which anybody may make by merely using his eyes.†

If the results of photometry yielded nothing more than an agreement with that common-sense estimate, the labour would

* "*Oculus ergo caret instrumentis & thermometro & organo analogis, sibi soli relictus judicium ferre debet.*"—*Photometria*, p. 8.

† "*In definiendis luminis gradibus solus oculus est judex.*"—Lambert, *Photometria*, p. 6.

be in vain. Allusion was made on p. 2 to the inability of the eye to judge the candle-power of a lamp or the relative candle-power of two sources of light with any degree of accuracy. By means of a photometer the relative candle-power may be measured with little difficulty to 2 per cent, and by taking suitable precautions, and after some practice and under favourable conditions, an accuracy of half of 1 per cent may be obtained. There is no disagreement here, but a development of our powers.

Photometry is not the measurement of an external or objective dimension or force, but of a sensation. It is difficult to make a quantitative measurement of our sensations. Two pigs under a gate make more noise than one pig, and while it is possible to measure the amplitude of the vibrations of air which produce sounds, and to estimate those which correspond to the faintest audible sound and those which cause the roar of a large organ, we know little of the quantitative measurement of sound. The attempt to apply measurement to sensations of smell has not met with success, and in spite of the delicacy with which different sensations of taste may be discriminated, it not only seems impossible to measure taste, but there appears to be physiological reasons for a rapid approach to a saturated condition of the sensation. A similar difficulty arises in the action of light on the eye.

Most physical measurements depend upon the observation of the relative position of parts of an apparatus, such as an index and a scale. The mistake is sometimes made of supposing that because photometers generally have an index and a scale, there is a direct connexion between the quantity so indicated and the quantity to be measured. The quantity indicated is generally a length, or in the case of certain photometers an angle, though in fact this is only the use of a graduated circle instead of a graduated straight line. The quantity to be measured is the physical intensity of a luminous radiation. The connexion between these is a psychological quantity, and this again depends upon a physiological function.

With the exception of a class of photometers which depend

upon the faculty for discriminating the small detail of a pattern or for reading printed matter, all others depend on the judgment of the eye for judging the equality of the illuminations of two screens or parts of a screen,* or for detecting a small difference between them. This is surrounded by psychological complications even when the illuminations are of the same colour; but when the colours differ new difficulties arise, and von Helmholtz has declared that no comparison worthy of being called a physical measurement can be made between lights of different colours, on the ground that the sensations are heterogeneous. It is true that with ill-devised apparatus and unsuitable methods some difficulties are experienced, but the judgment that two surfaces of different colours are of equal or of unequal brightness is an operation with which every artist in black and white or monochrome, and every engraver and etcher, is familiar.

At the time when the paper was written,† of which this book is an expansion, photometry had been confined chiefly to the commercial testing of gas, and a few scientific researches such as those of Sir W. de W. Abney and General Festing. As a department of physical science the subject does not seem to have been very attractive, probably because it is one of the least accurate kinds of measurement. Many attempts have been made to banish visual photometry altogether from the physical laboratory. At one time it was thought that the radiometer would supplant it, but it was soon found that the rotation of the "light-mill" depended on thermal rather than on luminous rays. The thermopile and the bolometer have been used to measure the whole radiant energy by means of electrical apparatus, and the dark heat rays or the luminous rays have been filtered out by selective absorption. Considerable accuracy is possible with such methods, but even if by great precautions changes of temperature have been avoided, and unsuspected radiation of heat guarded against, the proportion of luminous energy to thermal energy is so small that it is hopeless to arrive at any precise measurement of light alone. Photometers proposed by

* "Non tamen inter gradus claritas aliam dignoscere valet rationem praeter rationem aequalitatis."—Lambert, *Photometria*, p. 16.

† May, 1892.

Dessendier and by Lion, depending on chemical combinations of gases, may also be dismissed either as insufficiently developed or as unsuitable for practical purposes. And although from time to time the electrical properties of selenium give some promise of quantitative indication of the intensity of light, nothing with a pointer or an index such as Lambert wanted has been produced which can compete with an ordinary visual photometer, or enable a standard of light to be dispensed with.

There is a danger in all these electrical and chemical methods of measuring something that is not light. "Radiant heat and light," said Lord Kelvin,* "are one and indivisible. There are not two things, radiant heat and light; radiant heat is identical with light. . . . It is light if you see it as light; if it is not light you do not see it. . . . Radiant light is light if we see it, it is not light if we do not see it."

Photographic methods have been suggested; daylight and sunlight have been investigated by Sir W. Roscoe,† and under certain circumstances useful results might be obtained.

It was stated on p. 24 that an exposure of about 5 foot-candle-seconds gives a sensitive shade of grey on "slow" bromide paper. This might be used for integrating or averaging the whole illumination of a street by carrying a strip of such paper about in a systematic manner for a definite time over a definite area.

I have exposed in a street such a strip to an illumination of about 1 foot-candle for 5 seconds, and another strip from the same sheet was exposed at home, also for 5 seconds, to different illuminations, namely, 0.8, 0.9, 1.0, 1.1, 1.2 foot-candle. The two strips were then developed together in the same dish. This gave a number of bands of different tone, forming a scale, and the tone of the test strip could be compared with this scale, and its value estimated. The development of a number of strips can be quickly carried out, and, like indicator diagrams, they afford a permanent record of the measurements. But a considerable number of precautions would have to be taken,

* Kelvin, *Popular Lectures and Addresses*, i. 291.

† *Proc. Roy. Soc.*, Bunsen and Roscoe, 1862, p. 139, and Roscoe and Brennand, vol. xlix. Dec. 11, 1890; Richardson and Quick, *Phil. Mag.*, 1893, xxxvi. 459.

and in order to avoid differences of actinic power, selective filters or screens would have to be used. It would, indeed, be necessary to do more than this; screens would have to be used so that the measurements represent the effective or useful illumination as judged by the eye.

Discrimination Photometers.—Before entering on the discussion of photometers which depend upon the balancing of two equal illuminations, two classes of photometers based on the power of the eye to discriminate small details may be described.

Long ago, before any practical standards of light had been proposed, instruments had been used for estimating visual acuteness under various conditions, such as different degrees of illumination and various coloured lights. Printed slips or black-and-white patterns were used by Celsius, the Swedish astronomer, in 1735, apparently for the purpose of photometry.

He made it depend upon the distinctness with which we observe very small objects at different distances, in accordance with their greater or less illumination, and he did not take into account that it was even more difficult to reduce this distinctness to a certain law than it would be to measure the actual force of the light. He maintained that, to see some small objects in an equally distinct manner at twice the distance, it must be illuminated 256 times more, in accordance with the eighth power of the distance; but it is certain that if a very short-sighted person reads with facility small letters at 4 or 5 inches in a dim place, there is no light in the world which could make him decipher them at 14 or 15 inches, unless his eyes were of a most extraordinary kind.*

Buffon and Sir W. Herschel employed the same device.

In 1895 the idea was revived by Profs. E. J. Houston and A. E. Kennelly. At that time the inventors were unaware of the existence of any illumination photometer except that of Prof. L. Weber, which will be described later. Their instrument † consisted of a small oblong box containing a test object of small printed type at one end (A, Fig. 53) and a focussing

* Bouguer, *Traité d'optique*, p. 48. Referred to also in Bouguer, *Mém. de math. et de physique, Ac. des Sci.* 1757.

† Fully described in *The Electrical World*, New York, March 9, 1895.

eyepiece, B, at the other. One side of the box was provided with an opal glass window, C, over which a sliding shutter, D, could be moved.

The shutter controlled the lighting of the test object, and an index moving over a graduated scale was used to give the value of the illumination. To make a measurement, the window was placed to receive the illumination, and the shutter was moved until the test object was only just legible. The inventors asserted that "a certain intensity of illumination is required to render a definite object, viewed at a definite distance, clearly delineated to the eye." The focussing eyepiece was claimed to annul "the effect of any focal abnormalities of

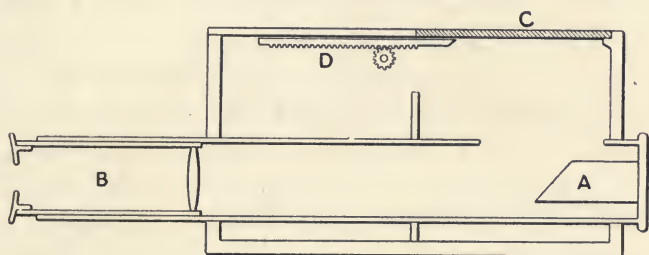

FIG. 53.—HOUSTON AND KENNELLY'S PHOTOMETER.

vision. The average deviation of any measurement from the mean of a number of measurements was modestly put at 10 per cent, and the results of different observers did not appear to differ more than this. The scale was, of course, graduated by experiment, and it was proposed to use it for candle-power photometry as well as for the measurement of illumination. The unfortunate name "illuminometer" was given to the instrument, and it is to be regretted that this mongrel word is sometimes used at the present day.

There is another class of discrimination photometer which must not be confused with the one which has been described. The first class endeavours to dispense with a standard source of light and to measure illumination by diminishing it in a known proportion until the test object cannot be distinctly seen; the second class endeavours to compare two different illuminations

with reference to their power of revealing small details. The condition of minimum visibility has nothing to do with this. Ritchie applied this principle to the photometer which will be described.

More than fifty years ago Mr. Sugg used printed test-slips for street photometry. He did not attempt to use the minimum illumination at which it was possible to read, but he used two slips—one was exposed to the illumination to be measured, and the other to a standard lamp.

In photometric work in the streets and public buildings of London in 1891-2, I occasionally read a Bradshaw, or the small type of Bellew's French Dictionary, rather for the purpose of trying whether any difference could be found by such a test,

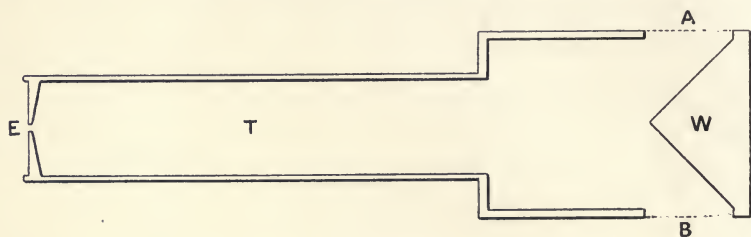

FIG. 54.—FLEMING'S DISCRIMINATION PHOTOMETER.

when illuminations due to electric arc-lamps and gas-lamps were the same as measured on a photometer. I found no perceptible difference.

Dr. J. A. Fleming has experimented in this direction. He has prepared* by photography test objects consisting of black or white dots one-fifteenth of a millimetre in diameter, or parallel lines of that width. At a distance of 10 in. from the eye, these have an angular magnitude of one minute.

He attaches these photographed patterns to the sides of a wedge W, Fig. 54. The lights to be compared are in the directions A and B. The wedge is observed through a diaphragm in the eyepiece E. No lens is used, but the hole in the diaphragm is only 1 mm. in diameter. The object of this small hole is to restrict the light to a beam smaller

* Fleming, *Journ. Inst. Elec. Eng.* xxxii. 156 et seq.

than the size of the pupil of the eye. This prevents the expansion of the pupil when the eye is directed to the dimmer side of the wedge, and its contraction when the brighter side is looked at. Experiment showed that the detail-revealing powers of four candles at 2 feet and nine candles at 3 feet and one candle at 1 foot are practically the same. It was found that when an arc-lamp was used, the detail-revealing power of the light was rather less than its brightness-producing power. These "discrimination" instruments must not be confused with photometers. They do not measure illumination, they cannot be used to measure candle-power. For certain purposes they may be very useful, but what they measure is acuteness of vision.*

The use of instruments of the first class, such as that of Houston and Kennelly, in an anthropometric or psychological laboratory would seem to be natural, for the purpose of testing and comparing the keenness of vision of different individuals, or of one individual under different conditions. The second class, if used with great care, and having regard to the physiological conditions of vision through eyepieces, might be employed for estimating whether ordinary photometers yield comparable measurements of illuminations when they are produced by different-coloured lights, or by sources of light of widely different intrinsic brilliance.

One of the first symptoms of failing sight is the difficulty of reading small print with a feeble illumination. This is experienced when the optical properties of the eye seem to be still so good that no lens can improve the focussing power. The chief reason appears to be that with a good illumination the aperture of the pupil is contracted, and this, by "stopping down the lens," gives a sharp image on the retina which cannot, perhaps, be improved by the help of a lens. But with feeble illumination the iris expands, and since with old age the power of accommodation (that is to say, the muscular control of the lens, and to a certain extent of the iris also) is diminished, the image is ill-defined. This action of the

* See Abney, *Journ. Inst. Elec. Engs.* xxxii. 180; Ayrton, *ibid.* p. 204.

iris must be distinguished from "focal abnormalities of vision," and cannot be annulled, as Houston and Kennelly suggest, by a focussing eyepiece, but can be dealt with by the small hole used by Fleming.

Photometers.—At first it would seem that photometers ought to be divided into two classes, one for measuring the candle-power of a source of light, and another for measuring the illumination at a given point on a plane set at a given angle and aspect. But on closer examination it is found that any instrument of the second class may be used with more or less convenience for measuring candle-power, and that every candle-power photometer depends on the observation of the illumination of a screen or screens. Those types which are peculiarly adapted for the measurement of illumination, and are less well suited for measuring candle-power, may be called illumination-photometers. It would be beyond the scope of this book to describe the numerous kinds of photometers which have been proposed for scientific purposes. The reader who is interested in such apparatus should consult the treatises of Palaz and of Liebenthal. A brief practical and critical description of a few leading types will be given, sufficient for the purpose of the engineer who desires a general knowledge of the subject. Though at first sight appearing very different, and having no structural resemblance whatever, it will be shown how these types are in fact so closely related that intermediate kinds may be found, filling up all the gaps. Visual photometers are in general a class of apparatus in which there is a gradual transition from each pattern to some other, and there is very little to choose between them.

Since this somewhat peculiar relation exists, it does not matter where we enter the line, and we may as well begin with the first three patterns in historical order, quoting the original description, and reproducing the illustrations.

The Bouguer Photometer.—No writers on optics up to the beginning of the eighteenth century seem to have paid attention to comparisons of intensities of lights. Leonardo da Vinci (1452-1519) indeed observed, "A body placed at an equal

distance between two lights will cast two shadows, one deeper than the other in proportion as the light which causes it is brighter than the other." Although several proposals had been made by astronomers for measuring what may vaguely be called "light," Pierre Bouguer published his *Essai d'optique sur la graduation de la lumière* in 1729, and in 1757 contributed a paper on "Means for Measuring Light, and Some Applications of these Means," to the Académie des Sciences. It is to be found in the *Mémoires de mathématiques et de physique* of that year. Many photometrical experiments are described in these writings, but without going into instrumental details. Bouguer died in 1758, and two years afterwards the Abbé de la Caille edited his papers, and the *Traité d'optique sur la graduation de la lumière* was published as a volume of the Académie des Sciences.

He alluded to a little book by a Capuchin, Père François Marie, *Nouvelles Découvertes sur la lumière*, published in 1700.

When he wished to measure the strength (*la force*) of a light he tried how many pieces of glass or of separate mirrors he had to use to make it completely disappear . . . in the same way as several other people who fell into the same error; but what rendered his expedients more defective, was the bad use he made of them.

He pointed out several objections to this method, which has often been revived in different forms.

The different state of the observer's eyes being more or less sensitive at one time than another, when his sight was a little fatigued all the lights should seem to him as a rule stronger; he had then need of a larger number of pieces of glass in order to diminish them equally. Each observer should then attribute a different value to the light which he measured. It was not possible to agree when observing at different times . . . and the measurements never gave the exact ratios.*

On p. 9 of the *Traité d'optique* he describes an arrangement which, though primitive, must be recognised as the first photometer.

* Bouguer, *Traité d'optique*, pp. 46 and 47.

To receive the two lights to be compared, a simple piece of cardboard ECD, as seen in Fig. 55, may be used, which has a fold CH, so that each half of the surface may be exposed more perpendicularly to each light. The whole of this piece of cardboard is black, but it has two holes of exactly the same size, say of three or four lines in diameter, to which paper soaked in oil, or two perfectly equal pieces

of glass, are applied, and these are made equally matt or white with emery or grit-stone. The oiled paper or the matt glass is sometimes more transparent than necessary; and I have more often used two pieces of ordinary very fine and very white paper, which I took side by side from the same sheet. I let the two lights fall on these two pieces of paper, and I judged the equality of their force by looking at them from behind, or sometimes from in front.

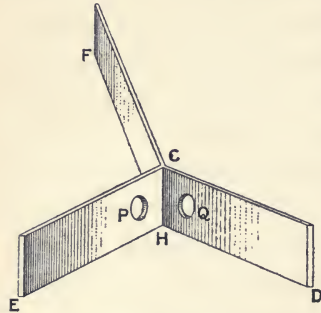

FIG. 55.—BOUGUER'S PHOTOMETER.

A second piece of cardboard FC served as a diaphragm, and prevented the two lights from mixing before illuminating the two little surfaces P and Q. This diaphragm was black on both sides, and joined to the first piece of cardboard exactly at the ridge which formed the fold.

He adds on page 14 that “the piece of cardboard FC forms an essential part of the instrument.”

After describing how lenses may be used to adjust the illumination of the two spots, when it is not convenient to move the lights, and how the “force” may be calculated from the relative positions of the lenses, he goes on to say :

At length I noticed that another point, of which I have already spoken, is not less important; it is to give exactly the same shape and same size to both parts P and Q which serve as images or pictures to make all the circumstances exactly the same for the observer who examines them. The two illuminated images cannot be too close one to the other; it is absolutely necessary for them to be seen at one glance, and it would be a good thing, if possible, to make their edges such as to touch each other. I have almost always looked at these same images through a hole made in another diaphragm, which I applied at some distance from the eye, and which hid everything else from me.

While the arrangement shown in Bouguer's illustration (Fig. 55) has not much to recommend it, the developments suggested in the last two sentences of the description convert it into nothing less than the photometer officially used by the Metropolitan Gas Referees at the present day.

The Rumford Photometer.—Lieut.-General Sir Benjamin Thompson, Count of Rumford, who demolished the theory of caloric by proving that heat can be generated at the expense of mechanical work, wrote to Sir Joseph Banks on December 20, 1792, a short account of "A Method of Measuring the comparative Intensities of the Light emitted by Luminous Bodies." This consisted in observing the shadows cast by a rod on a sheet of white paper. He went into some detail, but on March 1, 1793, he wrote a much longer letter, which, with the first, was communicated to the Royal Society.*

He described a carefully elaborated instrument, and proposed, if he might do so, "without being suspected of affectation," to "dignify it with a name, and call it a photometer."

The ordinary textbooks, whether on physics or photometry, illustrate and describe the Rumford photometer as an arrangement by which two lamps on a table cast two widely separated shadows of a rod on a large screen. Writers of textbooks have a habit of endeavouring to simplify descriptions of apparatus, at the expense of accuracy. This primitive arrangement has the sole merit that it is an example of an arrangement where stray light reflected from the walls of the room or from the ceiling has but little harmful effect, for it dilutes the two shadows equally. The textbook arrangement leaves out any consideration of the position of the observer, who apparently wanders round the table in the full glare of the lamps. Even so careful a writer as Palaz † says that "generally the two lights are moved along a divided scale perpendicular to the screen, but sometimes in any manner whatever; we then neglect the law of inclination. . . . In practice, if we wish to measure rapidly the intensity of a luminous source, say to within 10 or 15 per

* Thompson, *Roy. Soc. Phil. Trans.*, 1794, and *Phil. Trans.* Abridged, vol. xvii. The paper is also to be found in Rumford's *Collected Works*.

† Palaz, *Traité de photométrie industrielle*, p. 24, or Patterson's translation, p. 26.

cent, the Rumford photometer is very valuable, in that it is easy to set up, but it makes no pretension to giving results which are rigorously exact." This is not fair to Rumford. He paid the greatest possible attention to the angles of incidence, and nowhere speaks of moving lights along a scale perpendicular to the screen. The Rumford photometer was an admirable instrument, and the inventor was a highly skilled observer.

The complete apparatus for which the term Rumford photometer should be reserved (using the expression the Rumford principle for the bald use of two lights and the shadow of a rod), consisted of two cylinders in a carefully blackened box at the meeting point of two tables. One table was 12 feet long, the other 20 feet, and each was 10 inches wide. The box had two short tubes, through which the light passed on to a paper screen. The observer stood between the tables and examined the screen through a third opening between the two tubes. The apparatus is shown in plan in Fig. 56.

Finding it very inconvenient to compare two shadows projected by the same cylinder, as these were either necessarily too far from each other to be compared with certainty, or when they were nearer they were in part hid from the eye by the cylinder, to remedy this inconvenience I now make use of two cylinders, . . . and when the two lights . . . are properly placed, these two cylinders project four shadows upon the white paper . . . which I call the field of the instrument; two of which shadows are in contact precisely in the middle of that field, and it is these two alone that are to be attended to. To prevent the attention being distracted by the presence of unnecessary objects, the two outside shadows are made to disappear; . . . they fall . . . upon a blackened surface, upon which they are not visible.

As the diameters of the shadows of the cylinders vary in some small degree in proportion as the lights are . . . brought nearer to or removed farther from the photometer . . . I have added to each a vertical wing; . . . by means of these wings . . . the widths of the shadows are augmented so as to fill the whole field of the photometer.*

* Thompson, *Roy. Soc. Phil. Trans.*, 1794, p. 73, and Abridged *Phil. Trans.* lxxxiv. 362.

A cylinder with its wing is shown on a larger scale at A, Fig. 56. Rumford describes the apparatus in great detail. The lamps were moved by cords and winches, the handles are seen in the illustration. The sliding motion of the lights was "perfectly soft and gentle," an important matter, greatly

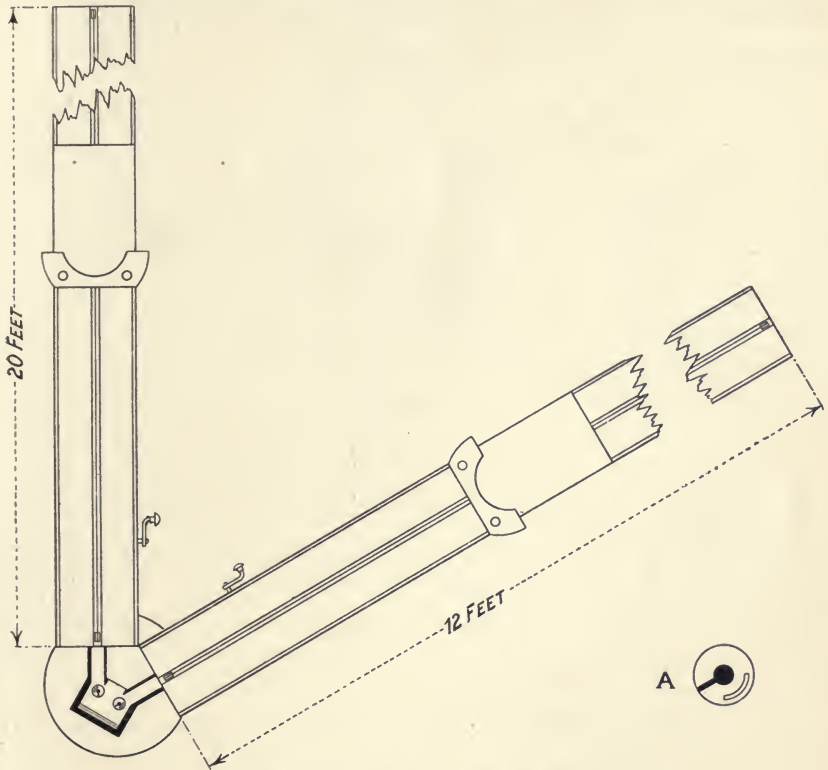

FIG. 56.—RUMFORD'S PHOTOMETER.

neglected in many modern laboratories. The scales on the tables were graduated for direct reading.

Rumford's *Experiments upon the Resistance of the Air to Light* appeared to yield no result, but they, indeed, reveal the remarkable accuracy of his work, seeing that he was using candles and oil-lamps. These experiments, in fact, serve only to show the errors of the observations, for under the conditions of the experiments he was doing nothing more than testing the

law of squares. The following figures are taken from the table of his fifth to his twelfth experiment :—

<i>Distance of light in inches</i>	203	198.3	202.1	204	198	192.2	191.2	192.4
<i>Calculated distance</i>	.	202	200.4	201.6	203	200	191	190.2

Lest it may be imagined that he was a man who could “fudge” or “cook,” the following extract will prove the contrary, and is worth quoting at length :—

In order that in judging of the quality of the shadows my mind might be totally unbiassed by my expectations, or by any opinions I might previously have formed with respect to the probable issue of the various experiments, keeping my eye constantly fixed on the field of the photometer, and causing the light, whose corresponding shadow was to be brought to be of equal density with the standard, to move backwards and forwards, by means of the winch which I had constantly in my hand, as soon as the shadows appeared to me to be perfectly equal, I gave notice to an assistant to observe, and silently to write down, the distance of the lamp or candle, so that I did not even know what that distance was till the experiment was ended, and till it was too late to attempt to correct any supposed errors of my eyes by my wishes or by my expectations, had I been weak enough to have had a wish in a matter of this kind. I do not know that any predilection I might have had for any favourite theory would have been able to have operated so strongly upon my mind, . . . but this I know, that I was very glad to find means to avoid being *led into temptation*.*

The Foucault Photometer.—From the Bouguer to the Foucault photometer there was but a step. Foucault shielded the transparent screen from stray light with a box, and provided an adjustment by which the dividing partition, nearly but not quite touching the transparent screen, could be set so that the two illuminated halves could be made to meet with hardly any shadow or bright space. Fig. 57 is copied from Foucault’s original illustration.† He found that two candles taken from the same packet varied at each instant, and gave the same light only accidentally, and almost always showed “a shocking

* Thompson, *loc. cit.* p. 90.

† L. Foucault, *Recueil des travaux scientifiques*, 1878, p. 103.

inequality." He therefore used a bunch of seven. Bouguer used four or five for the same purpose.

Foucault attached great importance to the construction of the screen, and recommended a layer of starch on glass. Other older writers give careful directions about screens. This may be accounted for by the irregular texture of the hand-made paper of those days.

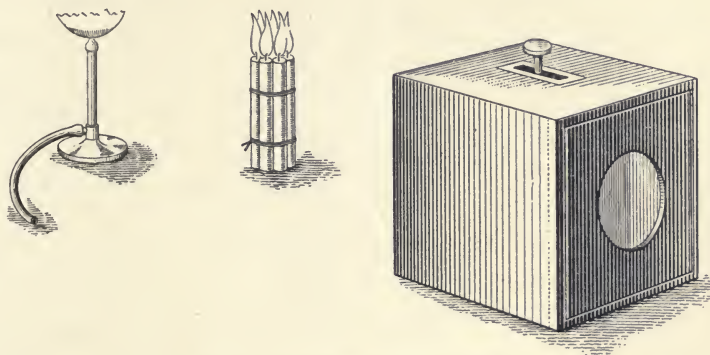

FIG. 57.—FOUCAULT'S PHOTOMETER.

The Harcourt or Gas Referees' Photometer.—The photometer in use at the present day in the official tests of the Metropolitan Gas Referees is essentially that of Bouguer, and the historical order may be interrupted to describe it. These officials and gas engineers use the word photometer to include a diverse collection of gas-testing apparatus, and the particular instrument which would generally be described as a photometer is called by them a photoped (Fig. 58). This nomenclature is well founded, for the photometer head or disc-box is only one of the two essential parts of a photometer, the other being the scale or its equivalent; but the word "photoped" has not been generally adopted.

It consists of two plates, each having a hole 21 mm. ($\frac{7}{8}$ inch) square. Between these a piece of suitable paper is pinched. A short tube slides within a tube 35 mm. ($1\frac{3}{8}$ inch) wide and 30 mm. ($1\frac{3}{16}$ inch) long, which is attached at right angles to the face of one of the plates, and carries a diaphragm having a rectangular opening 25 mm. (1 inch) high and 7 mm. ($\frac{3}{32}$ inch)

wide. Two rectangular spaces on the white paper are illuminated by the two lights, and by sliding the tube these spaces can be arranged so as to meet without perceptible overlapping, provided that the dimensions of the lights are small compared with their distance from the diaphragm.

It is important that the angle of incidence of the light shall be the same for each half of the screen. "This," wrote Rumford in the first of the two letters to Sir Joseph Banks, "may be easily performed by actually placing a piece of looking-glass, 6 or 8 inches square, flat upon the paper, in the middle of it, and observing by means of it the real lines of reflection of the lights from that plane, removing it afterwards as soon as the lights are properly arranged."*

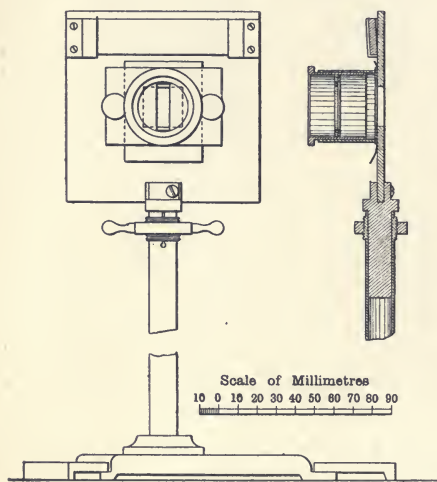

FIG. 58.—THE VERNON HARCOURT GAS REFEREES' PHOTOMETER.

screen 350 mm. ($13\frac{3}{4}$ inches) square, with a square hole in it, is placed between the observer and the photoped, and various other screens are suitably placed to cut off stray light. The official description of the material to be used for the screen is as follows: "The paper used in the photoped of the photometer shall be white in colour, unglazed, of fine grain, and free from water-marks. It shall be as translucent as is possible, consistently with its being sufficiently opaque to

In the Harcourt photometer a mirror is mounted above the screen, and is tilted slightly forwards. This is shown in the illustration.

If the photoped is symmetrically placed with respect to the two lights, the reflection of one in the mirror appears centrally when viewed from over the other. If this is not the case the photoped is turned on its stand until the adjustment is exact. A dark

* Thompson, *Phil. Trans. Roy. Soc.*, 1794, p. 68.

prevent any change in the apparent relative brightness of the two portions of the illuminated surface, when the head is moved to either side."

One of the lights is generally fixed at 1 m. from the paper screen, and the other is moved on a slide by means of a rod. This rod carries a graduated scale which is read against a fixed pointer. The movable light is adjusted until the illumination of the two halves of the screen appear to be the same.

The angular adjustment with reference to the lights has a twofold effect on the balance of illumination of the screen. It is evident that if the screen faces directly towards one light, it is receiving the maximum illumination that is possible at that distance, and that the illumination due to the other light will be less. It is possible to use the rotation of the photoped as a fine adjustment. After making an adjustment for the balance of two lights in the ordinary way, with the photoped symmetrical, one light is moved to give, say, 2 per cent difference of illumination, the photoped is rotated on the vertical axis until a balance is obtained, and the angle of rotation is noted. The light is again moved, and another angular adjustment made. The relation between the angles and the known differences may be found graphically, and an angular scale may be graduated for photometric measurements.

The Bunsen Photometer.—Having departed from the historical order, the description of the Ritchie photometer, which is the prototype of many varieties, will be postponed, and the well-known Bunsen photometer, of which there are only two forms, will be taken. It is a singular fact that while elementary textbooks of physics generally include a brief description of the Bunsen photometer, that description, except in a very few cases, is not only wrong and misleading, but is discordant with a simple experiment which any one can make, and the same mistake is to be found in books on photometry. The Bunsen photometer is usually described as consisting essentially of a spot of grease on white paper, or more scientifically, "a paper screen made unequally translucent in different parts, either by means of a circular or, better still,

ring-shaped spot of grease or stearin, or even by covering a part of a thin paper with a second thickness."*

This screen is placed between the two lights, and, according to one well-known book, "the method consists in sliding the photometer disc along the scale until the spot appears of the same brightness as the rest of the paper; the intensities of the lights are then proportional to the squares of their distances from the disc." Another excellent textbook says: "The lights to be compared are placed on opposite sides of this screen, and their distances are so adjusted that the grease-spot appears neither brighter nor darker than the rest of the paper, from whichever side it is viewed." It is difficult to believe that the writers of these descriptions can ever have tried the simple experiment. If a sheet of paper with a spot of grease on it is placed between two lights, it is generally possible to find a position at which the spot, when viewed from one side and at a certain angle, becomes almost invisible. But a change of the point of view will alter the balance, and the appearance on the other side is always quite different. The law of diffusion of light through translucent substances makes it impossible that there should be a complete disappearance. Some writers having, perhaps, made some such experiment, and feeling rather uneasy about the result, attribute the departure from their preconceived notion to a defect in the preparation of the grease-spot or to want of uniformity in the two surfaces of paper of which the disc is made. This widespread mistake is due to a desire to make the description simple. The erroneous description is often illustrated by a representation of two lights and a disc between them, provided with a grease-spot of this imaginary kind.

Dibdin, describing Bunsen's original photometer,† which was invented about 1841, says that the disc of paper marked with grease was enclosed in a box in which was burning a small gas-flame. The flame illuminated one side of the disc,

* Kohlrausch, *Physical Measurements*.

† W. J. Dibdin, *Practical Photometry*, p. 3. Mr. Dibden has said that as a matter of fact he did not know where to put his hand upon a real Bunsen photometer except that of Sir W. H. Preece, which was a near approach to it. That photometer is described on p. 200.

the reverse side of which was turned to one of the lights under comparison, and the distance noted. The box was then turned round, so that the disc faced the second light; a second reading was taken, and the distance thus found used for ordinary calculation. It appears that a system of double weighing was used, and no doubt in this method a disappearance of the spot was aimed at.

The modern Bunsen photometer consists of a grease-spot on a piece of paper, but it is always provided with two mirrors equally inclined, which enable both sides of the spot to be observed without any change of position of the observer, and the views of the two sides are seen at the same angle (Fig. 59). The angle is im-

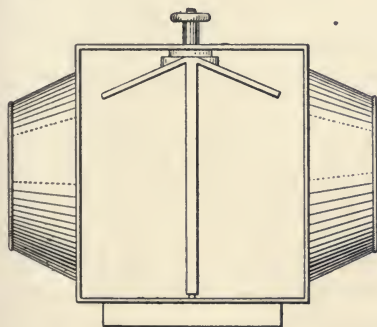

FIG. 60.—BUNSEN PHOTOMETER, PLAN, SHOWING DISC-HOLDER AND INCLINED MIRRORS.

material; an angle of 130 degrees or 140 degrees between the mirrors is convenient (see Plan, Fig. 60). The two images are necessarily separated, and some care is needed to avoid shadow of the mirrors on the disc. With a more obtuse angle the images are brought nearer together, but the spot is foreshortened; with a less obtuse angle a better view of the spot is obtained, but the images are separated. More or less complicated arrangements

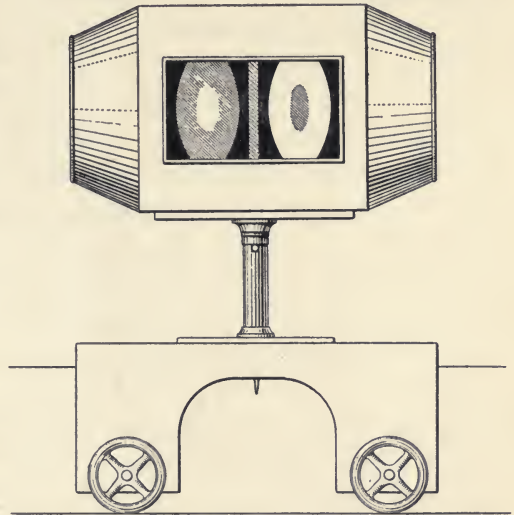

FIG. 59.—BUNSEN PHOTOMETER, FRONT VIEW, SHOWING THE SPOT OUT OF BALANCE, OWING TO THE ILLUMINATION OF THE DISC BEING GREATER ON THE RIGHT THAN ON THE LEFT.

With a more obtuse angle the images are brought nearer together, but the spot is foreshortened; with a less obtuse angle a better view of the spot is obtained, but the images are separated. More or less complicated arrangements

of prisms have been proposed to bring the images together, but these cannot be used without eyepieces.

When the balance is effected the spot does not disappear, but the appearance of the two sides is identical. In order to avoid stray light the screen, or the disc, as it is called by gas engineers, and the mirrors are always protected by a box. The box is mounted on a carriage which slides on a bar. In photometers having pretensions to high accuracy a double bar or two rods are arranged as an optical "bench." For most purposes the simple bar is better. The carriage should run on wheels, to give a smooth, easy motion. The carriage is provided with an index, and sometimes carries a prism or small mirror which reflects the light of one of the lamps on to the scale. A shutter is sometimes used, concealing the index until a reading is to be taken. This is in order to prevent bias. The most conscientious observer is apt to have his judgment disturbed if he can easily see the index and scale while he is adjusting a balance. The box and carriage of this and most other kinds of photometer is called the photometer head.

To make a sensitive Bunsen spot requires some skill and experiment. Good white blotting paper is an excellent material, but it is liable to become dirty. Thin drawing-paper is almost as good, but the size with which it is hardened resists the wax. There should be no perceptible water-mark. A variation from the simple round grease-spot is desirable, and it is a mistake to have a large one.

Different workers prefer different kinds of spots; some, testing 2500 to 3000 lamps a day, use a mere dab of oil or varnish, and do not mind unevenness if great translucency can be obtained. Gas engineers used to use a spot about 2 inches in diameter, but half an inch is considered too large by some electric lamp testers and their spots are about $\frac{3}{8}$ inch or 11 mm. diameter. The disc is mounted in a holder capable of rotation on a vertical axis. This enables any slight difference between the two slides to be detected. If any material difference is found on reversal the disc should be rejected. When the compensation or double-weighing method (which will

be described later) is used, want of symmetry is of no importance.

A good star-shaped or ring-shaped spot may be made as follows: Cut a star out of sheet metal, not less than $\frac{1}{16}$ inch (or 2 mm.) thick, about $\frac{3}{4}$ inch (or 20 mm.) over the points; or a washer 1 inch in diameter with a hole $\frac{3}{8}$ inch (or 10 mm.) diameter. Fasten it to a handle, melt a little paraffin wax or ordinary candle-grease in a cup, warm the star or washer, dip it into the wax, and then let it drain. The amount of wax that drains off depends on the temperature. Lay the paper disc on a sheet of blotting paper, and press the waxed tool on it. If the temperature is suited to the kind of paper employed, a neat uniform spot, practically alike on each side, may be made.

Wild rotates a disc of paper and dips the edge into melted wax, leaving the centre unwaxed, and ensuring the same quantity of wax on each side.

The only modification of the Bunsen disc that need be described is the Leeson disc. This consists of three sheets of paper; the two outer sheets are rather transparent, but not nearly so transparent as tracing paper, and the third sheet, which is placed between them, is of a stouter quality, and has a star-shaped hole. The difficulty of constructing such a disc is in holding the sheets closely together without cockling. It is not more sensitive than a good grease-spot.

Much theorising has been done about the action of the Bunsen disc. One of Lambert's simple axioms and a list of imaginary coefficients have been used as the basis for a string of algebraical expressions. But it is difficult to see how this mathematical treatment can help any one to make a better grease-spot, or to use it to greater advantage when it has been made. Some calculations seem to aim at securing tolerably good results from very bad discs.

The Ritchie Photometers.—The Bouguer photometer may be called a table photometer, and the arrangement of the Harcourt form of it for gas testing is essentially one for a table; the two lights and the screen form the corners of a

triangle. It seems that the arrangement of the two lights with a photometer moving in a straight line between them first occurred to William Ritchie, and he modified the Bouguer photometer with this object.

On Friday, 12th May 1826, at the Royal Institution, London, where he afterwards held a professorship, "Mr. Ritchie produced two or three forms of his very convenient new photometer, founded on the principles of Bouguer, an account of which has been read to the Royal Society of Edinburgh."*

The Edinburgh paper † begins by reference to "the celebrated Bouguer," who first discovered the important fact that the eye can detect a very small difference between two similar illuminated surfaces, "the only principle which has yet been applied with any degree of success in determining the relative illuminating powers of artificial flame." The instrument

consists of a rectangular box, about an inch and a half or two inches square, open at both ends, and blackened within for the purpose of absorbing the stray light. Within the box are placed two rectangular pieces of plane mirror, forming a right angle with each other. . . . In the upper side, or lid of the box, there is cut a rectangular opening, about an inch long and one-eighth of an inch broad. This opening

is covered with a slip of fine tissue or oiled paper. In the annexed figure ABCD is the box; CF, FD the two plane mirrors; EG the rectangular opening. . . . The rectangular slit should have a small division of blackened card at F, to prevent the possibility of the lights mingling with each other, and thus affecting the accuracy of the result.

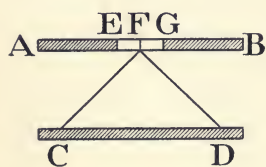

FIG. 61.—RITCHIE'S
PHOTOMETER.

In using the instrument, place it in the same straight line between the antagonist flames, at the distance of 6 or 8 feet from each other; move it nearer the one or the other, till the disc of paper appears equally illuminated on each side of the middle division, and the illuminating powers of the flames will be *directly* as the squares of

* *The Quarterly Journal of Science*, Royal Institution, London, xxi. 333 (1826). A concise description of the instrument is given on p. 376 of this volume.

† *Trans. Roy. Soc. Edin.* x. 443 (May 1, 1826).

their distances from the middle of the photometer. In moving the instrument rapidly between the two lights, we very soon discover a boundary, on each side of which the difference between the illuminated discs becomes quite apparent. By making the instrument move from one side of this line to the other, and gradually diminishing the lengths of the oscillations, we at last place it almost exactly in its proper position. It is very convenient to have a board of the same breadth as the instrument divided into equal parts. . . .

Instead of the two mirrors I sometimes use the same instrument, with a piece of white paper pasted on the faces of the mirrors, or on a piece of smooth wood forming, as before, a right angle. In this case the illuminated discs are viewed through the rectangular opening in the lid, without the intervention of the tissue or oiled paper. . . .

When the colours of the flames are different it is very difficult to ascertain the place of equal illumination. We can, however, as before, find the space over which the instrument moves before we discover an obvious difference between the illuminated halves of the oiled or white paper. We must then take the middle of this space, which will, even in that difficult case, give us a very good approximation to the truth. The same method was also used by M. Bouguer. . . . When one of the lights is of a fine white, and the other of a dusky red or blue colour, I prefer the following contrivance.

Procure a piece of fine white paper, and get it printed with small distinct type. Paste it on the rectangular opening in the instrument, which in this case may be somewhat enlarged. Brush over the paper with fine transparent oil. . . . Place the instrument between the flames, and cause two assistants to move them in either direction till you can just read them continuously along the paper with the same ease.

Some practical details of Ritchie's original pattern with mirrors are worth considering. If mirrors making a right angle are used, and are arranged as in Fig. 62, the observer being in the direction O, and if the translucent screen is removed, two images of the lamps in the directions A and B are seen separated by a distance equal to twice the projection of the meeting edges of the mirrors in front of the line joining the centres of the lamps. This is of no practical importance. But owing to the thickness of the glass, there is an unpleasant

shadow on the translucent screen, and with right-angled mirrors this cannot be avoided. The remedy is to set the mirrors at an angle of about 100 degrees, as in Fig. 63.* The beams reflected from them, therefore, converge and make an angle of about 20 degrees, as they do in the Harcourt photometer.

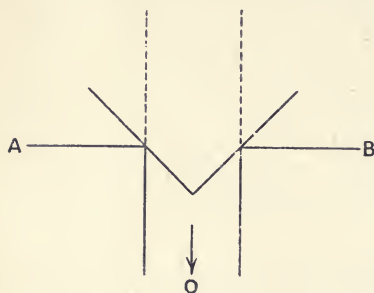

FIG. 62.

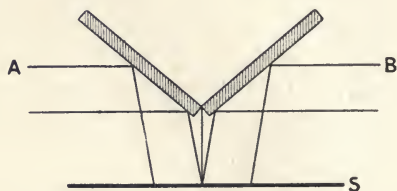

FIG. 63.

The position of the translucent screen S can then be adjusted so that the illuminated patches meet with a precision that would satisfy a Rumford or a Foucault. Not only can they be thus well fitted together, but the movements necessary for balancing lights of different candle-powers have no effect on this fit, and no fresh adjustment need be made. By applying a pair of suitably cut screens to the edges of the mirrors, the meeting line may be made zig-zag. In Fig. 64, A



A

B shows the appearance of the screen when out of adjustment. Some such device is often used in photometers, but the advantage is a matter of personal preference.

B

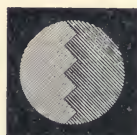

FIG. 64.

A photometer of this kind is excellent for ordinary work. Ritchie used it on a table with the screen horizontal, but it is more convenient to set the screen vertical, and to use it on a graduated bar. The slit, one inch by an eighth, may be

* In this illustration the thickness of the glass is exaggerated to show the principle. In practice an angle of 92 or 93 degrees will suffice. The angle depends on the thickness of the glass and on the distance between the mirrors and the translucent screen.

replaced by a circular hole about 1 inch (25 mm.) in diameter. It is a mistake to use a large screen, partly because it is difficult to secure uniform illumination, and partly because the attention is generally directed to one part of the dividing line, and the rest of the screen is comparatively useless. An eyepiece such as Foucault used in later forms of his photometer is unnecessary. This kind of photometer can be better used with both eyes. The use of an eyepiece may introduce physiological complications. A little stray light in the room falling on the outside of the screen dilutes both sides equally, and though it may reduce sensitiveness, need not cause error. A very useful photometer can be made in an ordinary match-box.

Tissue or oiled paper is not a good material. The Metropolitan Gas Referees have tested a large number of samples of paper and find that it is a mistake to use a very translucent one.

If the translucent screen is removed, the photometer bar is seen in the mirrors, folded up, as it were, to an angle of 4 or 5 degrees, with the two lamps side by side. If these virtual images of the lamps were replaced by real lamps, the arrangement would become a Foucault photometer.

It is interesting to find that among the numberless forms of photometers, Dr. C. V. Drysdale* has selected the Ritchie reflecting photometer as best suited for his research on the mechanical equivalent of light. He substituted totally reflecting prisms for the mirrors, and for hetero-chromatic work he employs a discrimination diagram, which, so far as it consists of letters, is exactly what Ritchie used for the same purpose.

The second form of Ritchie's photometer, namely, the two white screens set at an angle, has given rise to so many different modifications that some consideration may be given here to the angle of the wedge.

The Angle of the Ritchie Wedge.—The Conroy modifica-

* *The Illuminating Engineer*, London, vol. i. p. 544.

tion, which will be described later, is equivalent to a wedge having an angle of 60 degrees. The Thompson-Starling photometer consisted of two cards meeting at 70 degrees.

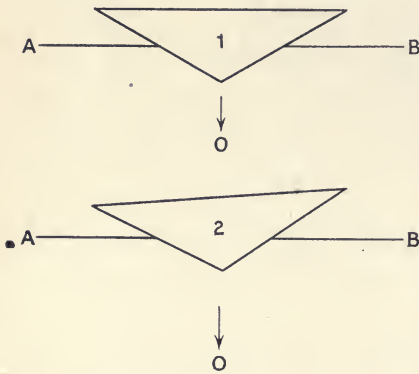

FIG. 65.

It is obvious to any one who is even vaguely acquainted with Lambert's cosine law, that if a wedge shaped like 1 in Fig. 65 is shifted by carelessness or by bad workmanship into the position shown at 2, the side illuminated by the light B will be much brighter than the side illuminated by the light A. But apart from any such error, the angle is clearly a bad one, for the illumination of the sides is much less than it need be. If we go to the other extreme, and use a wedge with a small angle, as in Fig. 66, it is true that the sides are illuminated almost as brightly as possible, but very little is to be seen of them, and the law of diffused reflection of light from unpolished surfaces, discovered by Bouguer, shows that the brightness will be actually less than if a more blunt angle is used. For most substances an angle of about 70 degrees for the wedge is best. A slight displacement of the wedge, or want of alignment of the lights, causes no appreciable error. For while the illumination of one side is diminished and the other increased, according to the cosine, the apparent brightness of each is altered in the opposite sense.

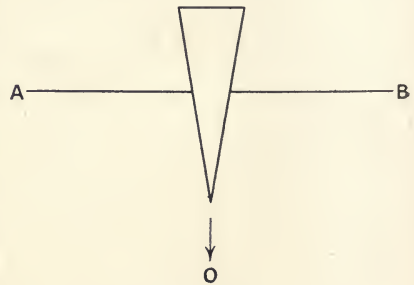

FIG. 66.

In developing my own modification of the Ritchie wedge, which consists of viewing one inclined card through a hole cut in another, I made some experiments to determine the best angle. Fig. 67 shows how the experiment might have

been done, though in fact it was carried out in a somewhat different manner. The light A illumines a screen at a fixed angle of incidence of, say, 30 degrees. Another screen, capable of angular movement, is illuminated by the light B. The figures indicate the angles of incidence. At angle 60 degrees the screen is considerably inclined to the light B, and in order to balance the illumination of the fixed screen this light must be brought close to it. Move the screen to angle 40 degrees, and the illumination is increased about 53 per cent (the ratio of $\cos 40$ to $\cos 60$) and the light B must be moved away in order to get a balance with the screen. The apparent brightness as seen in the direction O is also greater, but if the screen is moved to angle 20 degrees, while the illumination is still further increased to about 23 per cent more than at angle 40 degrees, the brightness as seen from O is less, because the screen is incapable of reflecting the full proportion of light at so oblique an angle.

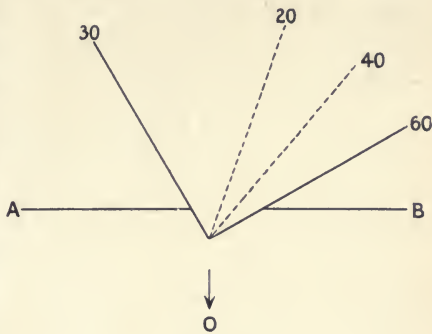

FIG. 67.

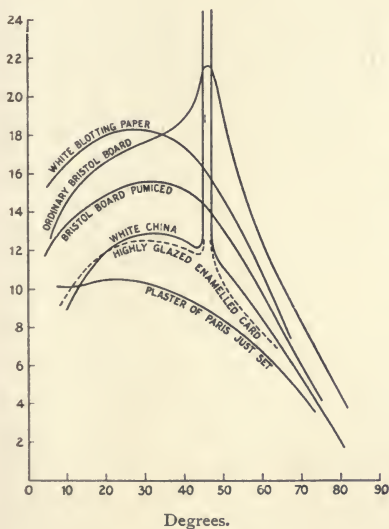

FIG. 68.

ordinates. Fig. 68 gives the curves for several different substances. I regret that I have lost the original readings, and can only reproduce the curves from a rather blotted copy in

This relation between the apparent brightness and the angle of the screen may be represented by a polar curve, but unless some simple trigonometrical function governs a relation, it is often better to use rectangular co-

a letter-book. Curves thus plotted from experiment should always show the observed points, and this I am unable to do until I have an opportunity of repeating the work. The substance giving the greatest brightness due to true diffused reflection was white blotting paper. The maximum was about 18.2 arbitrary units at an angle of incidence of about 27 degrees. At 22 degrees and at 33 degrees it was 18.*

At 5 degrees—that is, when the screen was turned nearly full to the light, but showed very little to the observer—the brightness was 15.6, and the brightness was of about the same value when the screen was moved through 45 degrees to make an angle of incidence of 50. Turning it through another 15 degrees, making an angle of 65 degrees, reduced the brightness to 8.5.

Ordinary white Bristol board, having a glazed surface, behaves very differently, due to the regular or specular reflection of the glaze. The specimen, though of the best quality, was not so brilliant as the white blotting paper, until the angle of incidence was 35. At this angle, regular reflection had begun to show, and the brightness increased rapidly as 45 degrees was approached. A maximum of nearly 22 was reached, and with greater angles the brightness fell off, remaining higher than that of the blotting paper. The same kind of card, lightly rubbed with pumice flour to remove the glaze, behaved very much as the blotting paper, the brightness being from 18 to 10 per cent less. With a piece of white china it was evident that the reflection was of two distinct kinds. It was like the blotting paper or pumiced Bristol board until 45 degrees was reached. At about that angle (and over a small angle on either side, corresponding with the apparent angular magnitude of the lamp which illuminated it) the brightness flashed up to a point far beyond anything that could be measured in this manner. Highly glazed enamelled white card behaved in the same way. These curves show

* When the two screens were made of exactly the same material, and fixed at the same angle, and equal lamps were placed at equal distances on each side, the brilliance was of course the same. One screen and its lamp was fixed, and the brilliance was taken at 10 units.

that the regular reflection of Bristol board and such materials extends over a considerable angle, but that so long as care is taken to avoid the angle of regular reflection, a highly polished white surface may be used in place of an unpolished one, and it may be said that no unpolished surface is so unpolished as a highly polished one except at the particular angle at which the polish is appreciable.

The best angle, therefore, is about 30 or 35, for a considerable change of angle between these limits makes no appreciable difference in the brightness of the screen. This is important for two practical reasons. Any slight error in construction or warping does not affect the symmetry of the photometer, and a slight displacement of one of the lamps, causing a change of the angle of incidence, produces no appreciable effect.

Angle Errors of the Ritchie Wedge.—Some writers with a child-like and touching faith in Lambert's cosine law, which is true enough, and indeed almost self-evident so far as incident illumination is concerned, and forgetful that, as Bouguer found, it does not apply to light reflected diffusely from a screen, have based various assertions about "angle errors" from figures found in a table of cosines. To these they fondly cling without trying experiments. It has been stated* that with a Ritchie wedge of 120 degrees (as in Fig. 65) "a deflection of the carriage of 1 degree will increase the illumination of one surface by 3 per cent, and reduce that of the other by 3 per cent, making a total error of 6 per cent. There are very few photometers in use in which the carriage cannot be deflected through this small angle of 1 degree, so the errors involved are perhaps more often greater than less than 6 per cent." The writer goes on to say, "Supposing that one of the lights is displaced horizontally and at right angles to the photometric axis by $\frac{1}{2}$ inch, the distance from light to screen being, say, 30 inches. This will cause the light rays to impinge upon the screen at an angle of 59 or 61 degrees instead of 60 degrees, and this will produce an error of 3 per cent in the measurement of candle-power. . . . With a photometer screen so arranged that

* L. Wild, "Causes of Error in Photometry," *The Electrician*, lvii. 529.

the rays shall fall perpendicularly upon the surfaces to be viewed, the error due to want of alignment is quite negligible, a displacement of one light by $\frac{1}{2}$ inch in 30 inches producing an error of only 0.02 per cent, this being the difference between the cosine of 0° and cosine 1° .*

These statements are true enough of incident illumination, but not of the brightness of screens, and are therefore not true of "measurement of candle-power."

The following experiment was made with a perforated screen photometer, but the results would have been the same with a Conroy or Ritchie wedge made of the same material.

Fig. 69 gives the results of tests of two different pairs of screens with two different pairs of lamps nearly 16 candle-

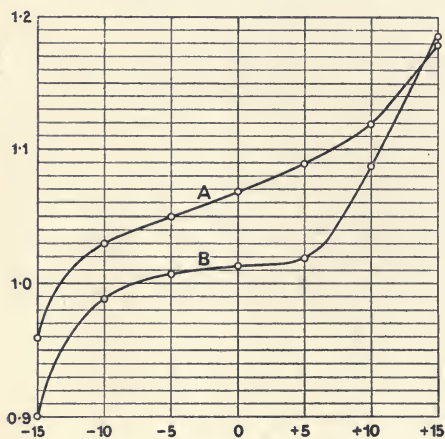

FIG. 69.—ANGLE ERRORS.

power each, and 100 inches apart. The want of symmetry of the curves is due to slight difference between the surface of the pair of screens. A very slight glaze disturbs the curve greatly at an angle of 10 degrees, for the incidence is then 45 degrees on one screen.

The photometer head was turned "against the sun" through 15° , its axis therefore pointed over my left shoulder. This is called +15 on the diagram. Ten readings were taken. The head was then turned through 5° successively until it pointed -15° to my right. The means of the sets of ten readings for each angle were as follows (see Curve A):—

Angles	- 15	- 10	- 5	0	+ 5	+ 10	+ 15
Readings	96	103	105	107	109	112	118

Between $+5^\circ$ and -5° the difference for 10 degrees is 4 per cent by actual experiment, and it may be safely deduced that for

* See also correspondence in the same volume of *The Electrician* on this subject.

1 degree the "angle error" is about 0.4 per cent instead of 6 per cent. Examination of Fig. 68 will show that the existence of this angle error depends upon the want of bilateral symmetry of the curve for dulled Bristol board about the ordinate 35.

Another pair of screens viewed not square with the bar, but square with the photometer head, gave the following means of sets of ten readings (see Curve B):—

Angles	- 15	- 10	- 5	0	+ 5	+ 10	+ 15
Readings	9004	9886	1008	1013	1018	1089	1186

The angle error for a difference of 10 degrees between $+5^\circ$ and -5° is one per cent. Another test gave $+5^\circ = 1095$, $-5^\circ = 1030$, or 0.65 per cent for 1 degree.

I have not tried displacing one of the lamps, but it would probably produce half the error.

The Conroy Photometer.—Taking this instrument in the historical order of date of publication (April 28, 1883)* we find it to be a modification of the Ritchie wedge. It will be remembered that Bouguer found that the two illuminated surfaces "cannot be too close together . . . and it would be a good thing if possible to make their edges touch each other." † That has been the aim of several inventors. Sir John Conroy says that the accuracy of the determination in shadow photometers depends on the edge of the shadows coinciding and yet not overlapping: the Ritchie photometer when constructed by bending a piece of paper round a wooden wedge gives an imperfect junction. He used two pieces of paper 3 cm. by 3 cm., held by india-rubber bands on blocks of wood. One piece of paper overlaps the other. He proposed that in order to avoid regular or specular reflection, the angle of incidence of the light on the paper should be 30 degrees, and that the line of light should make 60 degrees with the normal to the paper. "It is of course essential that the light should be incident upon both papers at equal angles, and that the papers should be so placed that no light can be reflected from one to the other."

* Sir John Conroy, *Phil. Mag.* xv. 423.

† P. 76.

Fig. 70 gives a half-size plan and side views, and Fig. 71

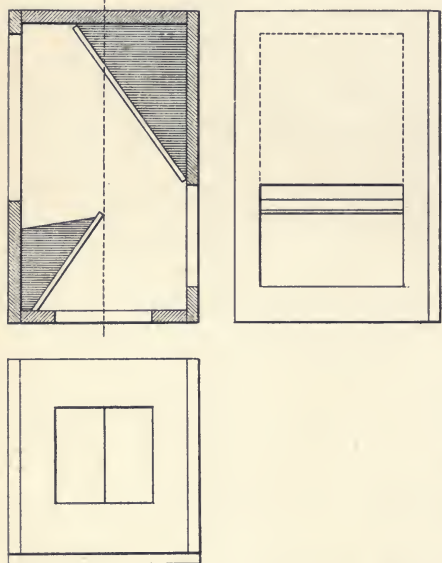

FIG. 70.—THE CONROY PHOTOMETER, PLAN AND ELEVATIONS, HALF SCALE.

at an angle of about 70 degrees. Silvanus Thompson says,

a perspective view of the proportions which after many experiments I find to be best for this excellent photometer. In place of paper screens held by india-rubber bands, I have used Bristol board, the glaze having been removed with a damp cloth, or white celluloid ground with pumice and water.

The Thompson - Starling Photometer.—Though designed and used in 1881, this modification of the Ritchie wedge does not appear to have been published until 9th June 1893.* It consists of a wedge

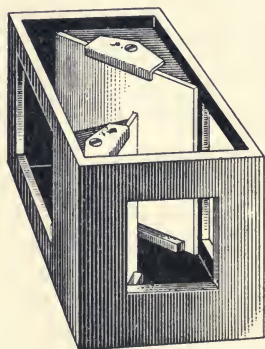

FIG. 71.—THE CONROY PHOTOMETER, PERSPECTIVE VIEW.



FIG. 72.—THOMPSON AND STARLING'S PHOTOMETER.

“When working with this photometer it was found that the

* *Phil. Mag.* xxxvi. 120.

precision of judgment of the eye as to equality of the two illuminations was impaired, if by bad workmanship any considerable width of blunted edge intervened between the two surfaces that should have met with precision." The principle of overlap and a sharp-cut edge, as afterwards adopted by Conroy, is used, and "he found," writes Thompson, "as I did, that 90 degrees is too large a dihedral angle for exact work. Materials such as card and paper are never entirely devoid of specular reflection." Fig. 72 shows two forms of overlap.

The edges of the cards of the Thompson-Starling photometer facing the observer should be sharply bevelled away. In the Conroy this is unnecessary, since at the line of junction the edge is turned away from the observer. Both Ritchie and Thompson set the wedge with the edge horizontal and looked down on it. It is more convenient to set it vertical at the level of the eye, and dust does not settle so easily on the screens.

The Lummer-Brodhun.—The photometers hitherto described are all of great simplicity, the optical arrangements are easy to understand, and the essential parts of them are easy to make. Early in this chapter* it was stated that certain types of photometers, though at first sight appearing very different, and having no structural resemblance whatever, are indeed closely related. The difference between the complicated photometer now to be described and the Ritchie wedge is obvious enough; the relation between them will be explained later.

The instrument appears to have been first described † in 1889. The illustration, Fig. 73, shows the essential parts. Light from lamps in the direction A and B falls on the two opposite sides of an opaque screen S. This screen is made of some carefully prepared white material, such as compressed magnesia or barium sulphate. Two mirrors or totally reflecting prisms are placed at M_1 and M_2 , and a pair of prisms are placed at P_1 and P_2 . These consist of an ordinary right-angled prism P_2 with a flat base, and a prism P_1 , also right-angled but having part of its base removed by sand-blasting or etching.

* P. 74.

† *Zeitschrift für Instrumentenkunde*, 1889, p. 41. *Lumière électrique*, xxxiii. 410.

The two bases are brought under pressure into optical contact. The whole arrangement is contained in a blackened box. Light from the direction A falls on the screen S, and is reflected in the mirror M_1 . Thence some of it passes straight through those parts of the prisms P_1 and P_2 which are in optical contact, and through a microscope, to the observer in the directions O, while the rest, falling on the sand-blasted portion of the base of prism P_1 which is not in optical contact, is stopped.

The light from the direction B, shown, for clearness, by a double line, is reflected from the other face of the screen S, on to the mirror or prism M_2 , and some of it passes straight through the prisms P_2 and P_1 and is lost, while the rest falls on that part of the base of P_2 which is not in optical contact, and is totally reflected to the microscope.

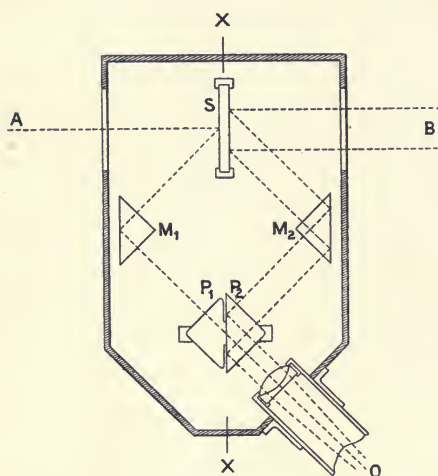

FIG. 73.—LUMMER-BRODHUN PHOTOMETER.

one side of the screen S, reflected in M_1 . Surrounding this opening he will see, reflected from the base of P_2 and reflected again in M_2 , the other side of the screen S. He will, in effect, see part of one side of the screen through a hole in the other side of it. This ingenious system of prisms seems first to have been employed for photometers by Swan in 1849.*

The instrument has been elaborated in several ways. Instead of a simple circular surface of optical contact between the prisms, the base of P_1 is etched so that a symmetrical pattern is produced. Fig. 74 shows such a pattern as seen when the photometer is out of balance. When a balance

* *Trans. Roy. Soc. Edin.* vol. xvi. (1849) and vol. xx. See also *Phil. Mag.* xlix. 118 (1900).

between two lights of a similar colour is effected, the field should be uniform all over, and the pattern should disappear. But the construction of the apparatus is so complicated, there are no less than twelve surfaces to keep clean, and such exact adjustment of the parts is necessary, that the whole of the field is seldom uniform, and the observer generally confines his attention to the boundary of one part of the pattern, and adjusts for the disappearance of that part only. The complication of the pattern defeats its own object. The instrument is a fatiguing one to work with, not only because the observer can only use one eye, but on account of the use of an eyepiece and the necessity of focussing. The telescope or microscope is considered to be an indispensable adjunct to any scientific instrument in Germany. Dow has shown* that with coloured lights very considerable differences in the apparent balance may be produced by varying the adjustment of the microscope. Perhaps an excuse for using this with a Lummer-Brodhun photometer is that the field is rather small, and may with advantage be magnified.

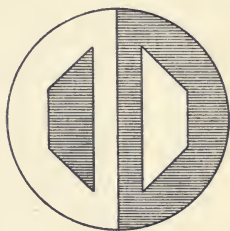

FIG. 74. — LUMMER-BRODHUN PHOTOMETER, CONTRAST FIELD OUT OF BALANCE.

Partly in order to reduce the fatigue, and partly to facilitate the comparison of different-coloured lights, a further modification has been introduced by shading one-half of each prism by a strip of plain glass about 1 millimetre thick. These absorb from 4 to 8 per cent of the light, and the result is that the trapezoidal patches are rather darker than the rest of the field. When a balance is effected, with lights of similar colour, the central dividing boundary should disappear, and the trapezoids should present similar contrasts with the field on which they appear. As with most photometers, unless the method of compensation or double weighing is used, the whole box must be turned about a horizontal axis to avoid error from want of symmetry. This axis, XX in the illustration, must pass through the surfaces of contact of the prisms, and through

* *Proc. Phys. Soc. of London*, xx. 250, May 25, 1906.

the middle of the screen. It is advisable also to try the effect of reversing the screen only. If on reversal a different setting is obtained, a mean must be taken between the two readings.

The Lummer-Brodhun photometer is essentially a laboratory instrument. To claim that in its most elaborate form it yields over three times the accuracy of a Bunsen photometer for lights of similar colour, does not mean that it is "three times as good" as a Bunsen. It means that those who wish to reduce the probable error of an observation to a little less than one-half of 1 per cent, and can secure the conditions for such work by avoiding other sources of error (such as a variation of 1 part in 1000 of the volts applied to a carbon glow-lamp, or a difference of 0.16 of a millimetre in the height of the flame of a Hefner lamp), may, if they have sufficient skill, attain this result by using a Lummer-Brodhun photometer.

A balance which will weigh a pound to an accuracy of a quarter of an ounce may serve for ordinary use in a foundry, but in a laboratory attached to that foundry such a balance would be useless, and an instrument of greater accuracy and much greater complication of construction and liability to derangement is necessary. Such a balance is suitable for the laboratory, though to use it for weighing castings in the foundry would be a waste of accuracy, time, and money.

The Wild Mirror Photometer.—L. Wild has made a photometer* closely modelled on the Lummer-Brodhun. The prisms M_1 , M_2 are replaced, as in some makes of Lummer-Brodhun, by mirrors, and instead of the pair of prisms P_1 , P_2 a partially silvered sheet of glass is used. A great advantage of this modification is that both eyes can be used.

The Perforated Screen Photometer.—I was led to design this form of photometer in 1892 (not having heard of the Conroy photometer at that time) after a long series of experiments in illumination in photometry. Illumination photometers as a class will be described later, but an account of the development of this photometer may be of interest here. I wished to make measurements as near the ground as possible, and

* *Illum. Eng.*, London, iii. 30 (1910).

arranged a box 6 inches each way, having a Bunsen screen horizontally on the top, one side open, and a mirror inside set at 45 degrees. A 1-candle-power electric lamp fed from an accumulator served to illuminate it. Hoods or tubes were used to exclude stray light, and the lamp was moved along a graduated scale. As it was impracticable to see both sides of the screen at once by means of mirrors, I proposed to observe the screen perpendicularly, and to graduate the scale by experiment. But I at once found that no balance could be obtained when the screen was viewed from a point immediately over it, without a very great disproportion between the illumination of the two sides of the screen. That is to say, when the illumination on the upper side was 1 foot-candle, the 1-candle lamp had to be much more than 1 foot from the back of the box. Viewing the screen at a definite angle was difficult. A ground-glass screen laid on the mirror was tried. This was found unsatisfactory, but the instrument began to assume a practical form when the mirror was replaced by a white card. Numerous experiments were made with different kinds of Bunsen spots and screens. Tracing paper stretched over a white card in which a star-shaped hole had been cut was found to be better than any grease-spot. The two sheets of paper used in the Leeson disc were unnecessary, since only one side of the screen was used. A scale was graduated by experiment, and this arrangement was practically used for street work. Further experiments with the view of finding the most sensitive Bunsen spot suggested the use of ground glass instead of tracing paper, and an oiled spot suggested the use of clear glass or of a simple cardboard screen with a star-shaped hole in it.* This was found to be far more sensitive than any of the previous arrangements.

Leaving the further development of this primitive illumination photometer until a later section, the practical form of this arrangement as a candle-power photometer may now be described.

Two screens (Figs. 75 and 76) are set at an angle of 70 degrees with each other, the angle of incidence of the light is

* *Proc. Phys. Soc. London*, xii. 355 ; and *Phil. Mag.*, July 1893.

35 degrees as with the Thompson-Starling photometer. Good white Bristol board (white cardboard) is an excellent material for

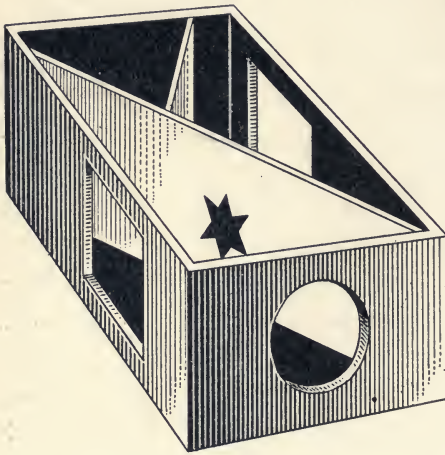

FIG. 75.—THE PERFORATED SCREEN PHOTOMETER.

these screens. The glaze must be removed with a damp cloth. When dry, the board should be laid face downwards on a piece of glass, hard wood, or celluloid, and a hole cut with bevelled edges. A star-shaped hole is a good shape. The edges which face the observer when the photometer is used must be sharply bevelled, those turned away from him may be square. A sharp knife must be used. It is better to cut a small hole first and enlarge it by paring. This avoids burnishing the matt surface by pressure. If it is neatly cut, and the cardboard of good quality, absolute disappearance of the hole is possible when a balance is effected, but to secure this illusion the hole should not be more than three-eighths of an inch (say 10 mm.) over all. A square hole or slot is much more easy to make. A round hole can be cut by fastening the card against a face-plate in a lathe. Fig. 77 shows the back view of a star hole cut in a blackened card; when seen foreshortened the star is symmetrical.

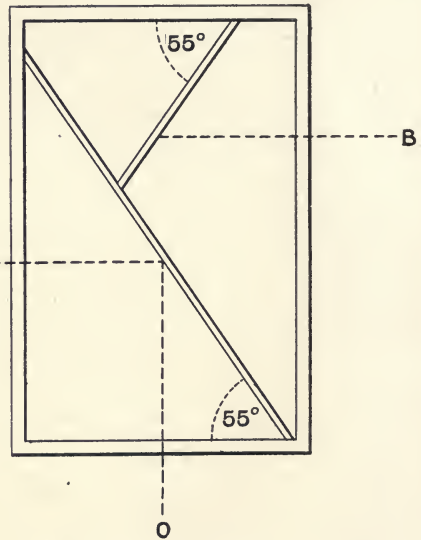

FIG. 76.—THE PERFORATED SCREEN PHOTOMETER.

It is necessary that the hole should be neatly cut, and that the cards should be fairly flat. The back of the perforated one must be blackened and screened from the light falling on the back screen.

This photometer is, as has been shown, the outcome of a series of modifications of an ordinary Bunsen grease-spot. It is at the same time a very slight modification of the Conroy photometer which seems to have nothing in common with a Bunsen spot. It carries out in the most simple possible manner the principle arrived at with so great complication and expense in the Lummer-Brodhun photometer, namely, seeing one screen through a hole in another.

I am not responsible for certain varieties of this pattern which have been called the "Trotter Photometer." There is so little new in the principle that I have never given it that name.

I prefer to stand at least at arm's length from the photometer head, and sometimes farther, working the lamps with cords or a light rod. It is then easy to use both eyes. If it is desired to cut down the area of the front screen, this should be done by a black oval mask on the screen and not by the use of a diaphragm in the front of the photometer head. The use of a diaphragm of small diameter interferes with the free use of both eyes. When the spot is observed from a short distance the illusion of disappearance is lessened, and one eye must be used. Although the central part of the retina is the best for discriminating detail, it does not follow that it is the best part for judging small differences of tone. Some observers find it useful to make a dot on the screen at about half an inch or more from the star, and to fix attention on this. The star hole is then "glimpsed" and not seen directly, but a smaller change can be detected, and a better balance can be made. Another way is to focus the eye for a point somewhere behind the screen. I have used a modification of this photometer for examining the reflecting power of various



FIG. 77.—STAR HOLE, AS SEEN FROM THE BACK.

substances, and at various angles.* It was generally necessary to use one eye if the nature of the surfaces of the two screens were not alike. Instead of shutting one eye a sheet of blackened card, having a hole about a quarter of an inch in diameter, may be used as a mask.

L. Weber invented this photometer independently, and described it at the meeting of the National Science Association at Schleswig-Holstein in April 1893.† He called it the Dach photometer, from the resemblance of the cards to a roof. The name Roof photometer has the merit of brevity, but it is hardly descriptive enough. Anything is better than using the name of one of the inventors, especially in these days of technological colleges and examinations.

After alluding to the "clever scheme worked out by Lummer and Brodhun," and "their highly ingenious arrangement of prisms," Weber writes :

Every theoretical requirement is fulfilled in the principle of my little Dach photometer, in that the spot (in this case the opening) has absolute transparency, and the surrounding cardboard is opaque, while each surface examined is illuminated from the one light source. For these reasons the Dach photometer gives the simplest solution of every theoretical demand. ‡

The Slot or Limit-Gauge Photometer.—A modification of the foregoing pattern consists in the use of three slots instead of a simple hole. This kind of screen is specially adapted for use with a photometer head fixed relatively to the working lamp. The slotted screen receives the light from the working lamp, and the plain screen at the back receives the light from the lamp under test. The working lamp is on the right. The right-hand side of the front screen being a little nearer the light is more brilliantly illuminated, and the left a little less. Similarly, the left-hand side of the back screen is a little brighter than the right. When a balance is obtained, the middle slot disappears, the slot on the right appears dark, and

* See page 93.

† *The Ill. Eng. of New York*, i. 901.

‡ *Zeitschrift für Beleuchtswesen*, October 30, 1906; *The Ill. Eng. of New York*, i. 901.

the one on the left appears bright. It is easy to arrange the slots as a limit-gauge for any particular candle-powers.

Let W (Fig. 78) be the working lamp of 10 candle-power fixed at one metre from the centre of the photometer head P , that is, from the centre of the middle slot of the screen. Let L be a lamp under test. If it is a 16-candle-power lamp it



FIG. 78.

will be 1265 mm. from P . But let a lamp of 14.4 candle-power, that is one 10 per cent less in candle-power, be placed at L . There will no longer be a balance at P . The point of balance will be shifted away from W . The point of balance may be found by the formula on page 114, and would be 0.4545 of the distance WL from W . But WL is 2265 mm., therefore the point of balance will be 1029.4 mm. from W , or 29.4 mm. to the left of the centre of the middle slot. Cut another slot, the centre of which is at this point, and the 14.4-candle-power lamp, though fixed at L , will balance here. In the same way it may be found that a right-hand slot, the centre of which is 26.5 mm. from the centre of the middle one, will balance a lamp 10 per cent brighter, that is, 17.6 candle-power. The projected view of these slots as seen in the photometer, when the middle one is in balance, and therefore practically invisible, will be as in Fig. 79, but an illustration cannot show the subtle differences of tone with accuracy.



FIG. 79.—SLOT PHOTOMETER, WITH CENTRAL SLOT IN BALANCE.

The arrangement of the slots in plan are shown in Fig. 80 to half scale. The displacement of the horizontal axes is considerable, and the working lamp should be moved about 90 mm. towards the observer. This displacement and the distances between the slots would be reduced

by the use of a working lamp of less candle-power, placed at a less distance than one metre.

A photometer arranged thus acts as an engineers' limit, or "go and not go" gauge. Lamps can be quickly sorted into three sets, those within the limits, those above, and those below, without any motion of the photometer or any reading of the scale.

The same principle may be used for facilitating ordinary measurements, without a definite relation between the slots.

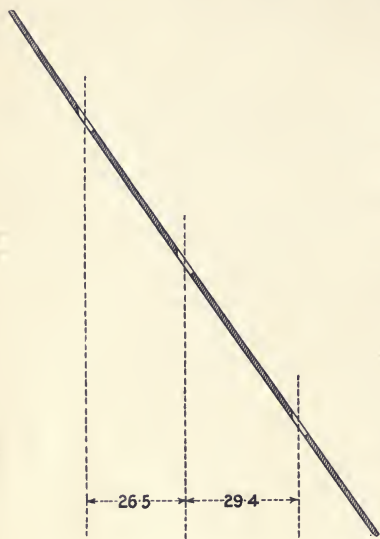

FIG. 80.—SLOT PHOTOMETER, PLAN.

If the lamps to be measured are of about the same candle-power as the working lamp, the distance between the slots can be determined from the scale. Take the working lamp as 10 candle-power. The division 10 is one metre from the photometer head. 10.3 is 1014.9 mm. from the head, or 14.9 mm. to the left; and 9.7 is 984.9 from the head, or 15.1 mm. to the right. Cut a slot on each side of the centre one, with centres at these distances. Aim for a balance with the middle one, and the two side slots being about 3 per cent high and 3 per cent

low, will help in getting a balance, and will give an indication of the precision with which the adjustment is being made. These distances are the apparent or projected distances. For a screen set at 35 degrees, the actual distances are 1.74 times greater (the reciprocal of $\cos 35^\circ$); but it is easier and quite accurate enough to set them out graphically as in Fig. 80.

When seen in the photometer the slots will lie at the right distances for 3 per cent difference on such a scale with the two 10-candle-power lamps, and a somewhat altered difference when one of the lamps is greater or less than 10 candle-power. A working lamp of only 1-candle-power is quite suitable for measuring lamps of 50 to 80 candle-power.

The Grid Photometer.—Ordinary photometers are suitable for measuring the candle-power of a steady light. If the candle-power frequently alters, only occasional measurements can be made when a balance can be caught. In 1894, when I was endeavouring, at the suggestions of Prof. S. P. Thompson and Mr. J. Swinburne, to obtain a standard of light from an arc lamp,* I found that the light was continually varying, and I devised a form of photometer by which the fluctuations could be followed, and the instantaneous value could be determined at any time. Such a photometer is not likely to be required except for such researches, but it may be described here as it is of the Ritchie or Conroy type.

At this time I had not recognised that 45 degrees is a bad angle for a Ritchie screen, and I used that angle, and had to take considerable care to avoid specular reflection. The photometer

consisted of a long narrow screen set at 45 degrees to one light, and in front of this, inclined at 45 degrees to the other light, and making 90 degrees with the former, there was a screen consisting of a large number of narrow bars forming a grid (Fig. 81). The screens are enclosed in a box, and are observed from the direction O. The lights fall

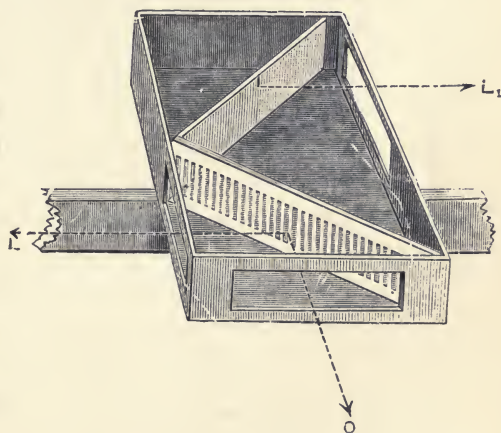

FIG. 81.—GRID PHOTOMETER.

on the screens through two openings from the directions L and L_1 . The lamps are arranged opposite the middle of each opening. The screens were about 12 inches (305 mm.) long; the lamps were displaced about $4\frac{1}{2}$ inches (114 mm.) from the centre line. Sighting points or a parallax mirror are needed for keeping the direction O at right angles to the bar. The grid should be observed from a distance of 6 or 8 feet.

* P. 12, and *Journ. Inst. Elec. Eng.* xxi. 360.

When two steady lights are used, the bars on the left of the grid are brighter than the back screen, and the bars on the right are less bright. A band of uniform tone is seen between the two. When the whole box is moved this band remains stationary. When one of the lamps varies, the band may be seen moving backwards and forwards. Its position may be read with reference to the scale on the bar below.*

The Joly Photometer.—One other kind of photometer for ordinary purposes remains to be described. This, the invention of Prof. J. Joly of Dublin,† has been independently proposed by other workers. It consists of two blocks of paraffin wax set side by side. Light falling on the side of a block causes the whole of it to appear to be suffused with light, when the edge is viewed at right angles to the direction of the light. Although a good deal of light passes through the first block, into and through the second, the optical break of continuity between the blocks is such that the block next to the source of light is much more brilliant than the second one. It is evident that if another light is allowed to fall on the second block, in the opposite direction, a balance may be obtained. The delicacy of this balance depends on the relation between the thickness

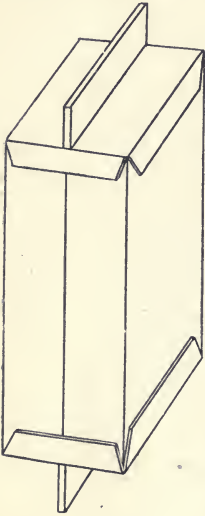

FIG. 82.—THE JOLY PHOTOMETER (full size).

of the blocks and the amount of illumination falling on them. It depends also on the nature of the material. The wax should be cast in a non-conducting mould, such as a match-box, or in a warm metal mould, and should cool slowly. Ample allowance must be made for contraction during solidification. The sides can be finished with a carpenter's plane. A pair of paraffin blocks each 10 mm. thick are not sensitive to the usual illumination of 1 foot-candle or 10 metre-candles. Blocks each about 5 mm. thick give good

* For further details see *Phil. Mag.*, July 1893.

† *Phil. Mag.*, July 1888, xxvi. 26.

results with such illumination, but some workers might think the surfaces are too narrow for convenience. Joly did not propose any dimensions for the wax blocks, but he suggested also the use of translucent glass with a sheet of silver foil cemented between the blocks. For these he recommended 20 mm. by 50 mm. by 11 mm., the first dimension being the depth in the direction of view, the second the height, and the third the width of the face of a single block, as seen by the observer. Photometers consisting of blocks of translucent opal or milk glass made by Krüss are used for sorting lamps at the Robertson Lamp Works at Hammersmith. The opal glass is much more translucent than paraffin wax.

When in balance, the blocks appear equally and almost uniformly bright. But on disturbing the balance it is seen that the less brightly illuminated block has a grey band next to the dividing line, and with a rapid reversal of balance this band seems to shift from one block to the other. If an attempt be made to bisect this band by the dividing line, a more accurate balance can be effected than by merely trying for equal brightness of the two blocks. This curious band, due probably to what psychologists have termed simultaneous contrast, should be looked for in comparing lights of different colours, as it greatly assists the balance in that case. It may be seen, but not so easily, in a Conroy.

CHAPTER VI

ACCESSORY APPARATUS

Photometer Scales.—Attention may now be given to an important accessory of all measuring instruments, namely, the scale. It is customary in educational laboratories to provide nothing but simple scales of centimetres or inches, in order that the students may have to calculate their results. For ordinary work, direct-reading scales are always used, and these, though based on the law of squares, can be arranged in several different ways. In using a photometer of the Rumford or Foucault type, such as the Harcourt photometer of the Metropolitan Gas Referees, the scale is simply a scale of squares. One lamp is fixed and the other is moved. The standard is generally fixed. Count Rumford says that his standard lamp was “always placed exactly opposite to that division of the scale which is marked 100. . . . This division is, of course, at the distance 31.62 inches from the middle of the field of the instrument” (that is to say, his screen), “that marked 10 degrees being at a distance of 10 inches.” The only change that need be made for modern work is to alter a decimal place and to set the standard at 10 if a 10-candle standard is used. The scale is therefore graduated as in Fig. 83, where L is the far end of the scale and S is the end next to the screen. The scale AB is a uniformly divided scale, to show the relation. But it is not convenient, in the case of the Foucault photometer, to attach an index to the lamp itself. A long rod is used, easily accessible to the observer, who sits behind the screen. The lamp is moved by pushing or pulling this rod. The scale may be fixed on the table and an index

carried on the rod, as shown in Fig. 83, or the index may be attached to the table and the scale may be carried on the rod, as in the same figure. In this case the scale is reversed. The latter is generally the best arrangement, for the index is always in the same position, and can be fixed where it is most convenient.

If we take squares of inches, calling 10 inches 1 candle-power and 40 inches 16 candle-power, the graduations may be found from Barlow's tables, taking 40 as the square root of 1600, 39.749 the square root of 1580, and so on. If 48 inches is taken for 16 candle-power, a scale of decimals of a foot should be used. 1 candle-power is then at 1 foot. If the metric scale

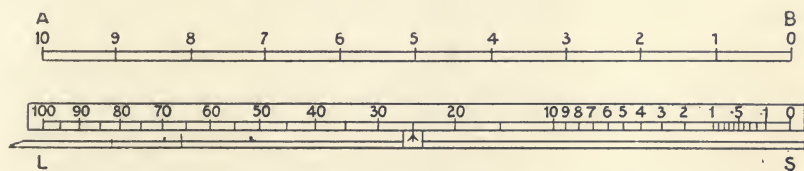

PHOTOMETER SCALE FIXED, POINTER MOVABLE.

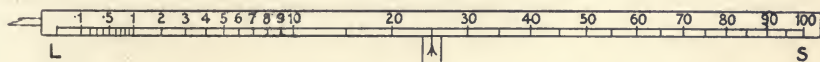
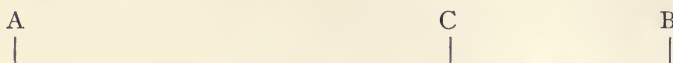

FIG. 83.—SCALE MOVABLE, INDEX FIXED.

is adopted, 16 candle-power will be at 126.49 mm. The square root of 160 is 12.649.

In the case of the Bunsen photometer, as generally used, the two lamps are fixed and the photometer head moves between them. The middle of the scale is marked 1, being the ratio of the candle-powers. The total length of the scale is generally 100 inches (254 cm.) or 60 inches (152.4 cm.) or 2 metres (78.74 inches). The graduations are not carried to the ends, as large ratios are difficult to measure. With a 100-inch bar, and a 16-candle-power lamp at each end, the photometer at the mid-point receives an illumination of about 1 foot-candle. This is a good illumination for most photometers. With too bright or too feeble an illumination high accuracy cannot be obtained, but the practical range is very large.

When one lamp A is of 16 candle-power, and the other B is 4 candle-power, the photometer head C is at such a position that AC is twice BC. If BA is 100 inches, AC is $66\frac{2}{3}$ inches



and BC is $33\frac{1}{3}$ inches. The scale may be calculated from the formula

$$l = \frac{L}{1 + \sqrt{n}}$$

where l is a length measured on the bar, L the total length of the scale, and n the ratio of the candle-powers of the two lamps. This can be set directly on a slide-rule, as in Fig.

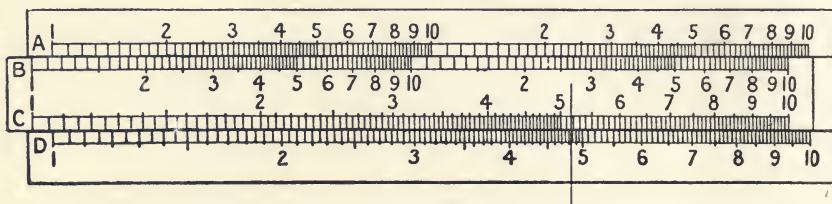

FIG. 84.

84. For example, to find on a 100-inch scale the ratio corresponding to 48.4. Set 100 minus 48.4, that is 51.6 on C over 48.4 on D, and over 10 on B find 88 on A. But for graduating a scale it is better to use a table of square roots and a table of reciprocals. For example, to find on a 100-inch scale the graduation representing the ratio 2.5 to 1, look out the square root of 250, and find 15.811. The square root of 2.5 is, therefore, 1.5811. Add 1, and look out the reciprocal of 2581. This is given as 3874467. This means, say, 38.75 inches from the end. The decimal places can be found by inspection. A table for a scale 100 units long is given in the Appendix, and Fig. 85 gives an idea of the general appearance and a portion of the middle of such a scale, full size. It is not difficult to read to 2 per cent, but it is not worth while to graduate the scale to less than 1 per cent, for though under favourable conditions readings may be repeated

to 1 per cent, and from a mean of a number of such readings a result may be given to half of 1 per cent, such measurements are of the nature of guesswork, and the intermediate position of the index may be estimated more accurately than its true position can be found.

While this form of scale has been largely used for general photometric work, since it is independent of the actual candle-power of the lights and deals with ratios, it is not a direct-reading scale, unless the standard lamp is of 1, 10, or 100 candle-power. A scale 100 inches long is much too long for comparing lights of about 1 candle-power, and too short for lights of about 100 candle-power. If a 1-candle and a 10-candle-power lamp be compared on such a scale, the illumination at the photometer

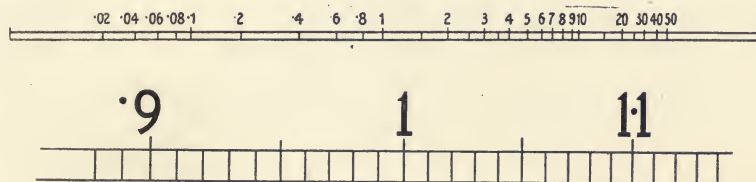

FIG. 85.—THE RATIO SCALE.

is only about a quarter of a foot-candle. The usual practice for gas-testing used to be 2 candles at one end and 16 candle-power at the other, giving 2.4 foot-candles at the photometer.

The Compensation Method.—For ordinary measurements of lamps, the method of double weighing, with simple scales of squares, is the most convenient. The scales may be arranged as in Fig. 86, the graduations being the same as those in Figs. 83 and 84, but arranged right and left of zero. For commercial work it is usual to divide the scale into quarter candle-powers in the neighbourhood of 16 candle-power. For scientific work it may be carried to decimals. The standard lamp is placed on the left, over the graduation corresponding to its known candle-power. The photometer head is fixed at zero, and the lamp to be measured is moved along the scale on the right, until a balance is found. An index attached to the lamp-carrier gives the candle-power.

The method of compensation presents several advantages. A working lamp and a standard lamp are generally used. The working lamp may be an electric glow-lamp with some sensitive form of instrument for indicating, but not necessarily for measuring, the current, and with an adjustable control of the current; or a good paraffin lamp may be used, provided that it has been burning for at least a quarter of an hour before use. The standard lamp may be a Hefner or a Harcourt lamp, or an electric glow-lamp giving a known candle-power with a known and carefully measured current; no voltmeter is needed. The photometer head is fixed at zero on a scale such as that shown in Fig. 86. The working lamp is put on the left, and the standard is set at its known candle-power on the right. The working lamp is then moved until the photometer gives a balance, and then it is fixed. The standard lamp is removed

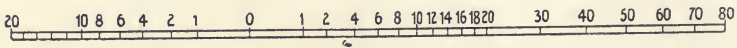

FIG. 86.—DOUBLE SCALE OF SQUARES.

and put away until it is desired to check the working lamp. Lamps to be measured are moved on the right of the photometer, and when a balance has been found the candle-power is read directly on the scale. In this method the candle-power of the working lamp need not be known, and the left-hand part of the scale need not be graduated. It is only necessary that the working lamp shall not vary in candle-power during the work.

Such an arrangement has the advantage that the standard need not be moved along the scale. A Harcourt Pentane lamp is, of course, quite unsuitable for being moved, and a Hefner lamp, though comparatively light, is liable to flicker. Besides this it is more convenient to keep the photometer head fixed, especially if a Lummer-Brodhun with a slanting telescope is used. The observer can sit in one place with his notebook at hand, and need not even move his head. The lamp to be tested is mounted on a movable carriage worked by a cord or a light rod. This is the

arrangement recommended by Fleming,* and is used at the Edison and Swan factory.

But sometimes the lamp to be tested cannot be moved. Owing to the shape of the filament of an electric glow-lamp, and to reflections from the glass bulb, the candle-power is not the same in all directions. One of the methods for obtaining the mean horizontal candle-power is to spin the lamp by means of a motor; another is to surround the lamp by a number of mirrors which reflect the light on to the photometer. A method for obtaining the mean candle-power in all directions is to enclose the lamp in a large globe painted white inside. The lamp itself is not visible from the photometer, but the diffused light is measured. When such appliances are used it is inconvenient or impracticable to move the lamp under test. Metal filament lamps as at present made are often so brittle that it is not desirable either to move them or to rotate them.

In order to retain the principle of a fixed distance between the working lamp and the photometer head, these must be attached together by a rod after the adjustment has been made against the standard, and they must be moved together along the scale.

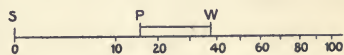

FIG. 87.

The standard lamp S (Fig. 87) is first placed over the zero of a simple scale of squares, and the photometer head P is placed over the number corresponding with the known candle-power of the standard. The working lamp W of any convenient candle-power is moved on the right until a balance is obtained, and it is then clamped by the connecting rod to the photometer head. The standard lamp is then removed, and the lamps to be tested are put successively in its place. The pointer for the scale is attached to the photometer head.

If for any reason both the lamp to be measured and the photometer head are to remain fixed, then the working lamp must be moved, unless some other means, such as those to be described later, are used for adjusting the illumination of the

* Fleming, *Journ. Inst. Elec. Eng.* xxxii. 143.

photometer. If the working lamp be moved, a scale of reciprocals of squares must be used.

To prepare this, Barlow's tables are useful. Let 10 candle-power be indicated at 1 metre. To find the position of the graduation indicating 1.1 look out the nearest reciprocal to 1,100,000; this will be found to be 1,100,110, and is the reciprocal of 9090. The number 9090 does not concern us, but its square root, 95.3415, gives the distance of the graduation, namely, 953.4 millimetres.

In the process of double weighing, the object to be weighed is first counterpoised, and is then taken out of the scale pan and weights are added until the counterpoise is balanced. The weight of the counterpoise and the ratio of the lengths of the arms need not be known. But in this double photometric method it is important that the photometer head shall be so placed with respect to the zero of the scale, that the law of the squares of the distance is satisfied. When a movable photometer is used on a ratio scale as in Fig. 85, it is not only necessary that the index shall be carefully fixed with reference to the head, whatever type of photometer be adopted, but the head, or at all events its essential part, such as the disc of a Bunsen photometer, should be reversible, and reversal should not affect the balance. With the method of double weighing this reversibility is not necessary, and want of symmetry, to which many kinds of photometers are liable, does not introduce error. When the lamp to be measured is of approximately the same shape and candle-power as the standard lamp, errors due to stray light practically disappear, but precautions should always be taken against this fault.

The method of keeping a fixed distance between the photometer head and the working lamp has a considerable advantage over the older method of moving the photometer head between two fixed lamps, because the illumination of the screen, whatever type of photometer is employed, is constant. That illumination can therefore be chosen which gives the highest accuracy. No careful investigations seem to have been made to discover the best illumination. It probably differs with different kinds of

photometers. The Gas Referees use a distance of 1 metre between the 10-candle-power lamp and the photoped, giving 0.93 foot-candle. But they observe the light *through* the paper screen. The brightness of their screen as seen when in balance is as though it received about 0.28 foot-candle illumination from the observer's side. Fleming uses a 16-candle-power lamp at 4 feet, giving 1 foot-candle, and Paterson at the National Physical Laboratory uses 10-candle metres. In the Lummer-Brodhun photometer the field as seen by the observer is considerably less bright than a white surface illuminated with 0.93 foot-candle, not only in consequence of the various reflections and prisms, but by the magnification of the image by the microscope. In a careful examination of the accuracy to be obtained from various types of photometers, Kennelly and Whiting* used a 5-metre bar and a 16-candle-power lamp at each end, giving only 0.24 foot-candle. Hugo Krüss, writing in 1886,† discusses the best length for a photometer bar. He recommends at least 5 metre-candles, say, half a foot-candle on the screen. He suggests 2.08 metres for 10 candle-power, and 2.74 metres for 20 candle-power. He was probably working with two candles on one side and a 10- or 20-candle-power gas-burner on the other. It is probable that not only the type of photometer, but the preference of each particular observer, should be taken into account in deciding the best working illumination. The fixed-distance method gives complete freedom for choice in this matter.

If the working lamp is of 16 candle-power, a 100-inch bar would only allow 16 candle-power as a maximum on the measuring side. But there is no reason for using a working lamp of candle-power of about the same magnitude as the lamps to be measured. It is sometimes asserted that for good work the ratio between the two lamps should approach unity, but it is difficult to find any adequate reason for this assertion. It is impossible to tell by looking into a photometer head when adjusted for a balance whether the ratio of the candle-powers is

* National Electric Light Association, New York, May 1908.

† Schilling's *Journal für Gasbeleuchtung*, 1886, p. 893.

more nearly 1 to 1, or 1 to 100, or 100 to 1. Care must be taken to adjust the position of the lamp to be measured, with respect to the pointer on the scale, but no pointer or scale is necessary for the working lamp when the method of double weighing is used. Excellent work can be done with a working lamp of 1 candle-power.

With the old-fashioned arrangement of a lamp fixed at each end of the bar, and a photometer head moving between them, the scale becomes contracted at the high candle-powers, and considerable care must be taken that the standard lamp is exactly over the end of the scale.

With a scale of squares for the compensation method, a working lamp of 10 candle-power and a lamp under test of the same candle-power, one being 1 metre to the right and the other 1 metre to the left of the photometer head, a displacement of 24.7 mm. is equivalent to a change of 5 per cent in the candle-power of one of the lamps, but if the lamp under test is of 50 candle-power, a displacement of 5.5 mm. is equivalent to a change of 5 per cent. There is, however, no greater difficulty in obtaining a good balance in the latter case than in the former.

The Illumination Gradient.—In any photometrical arrangement depending on the law of the squares of the distances, the decrease of the illumination on a screen at greater and greater distances may be represented graphically by a curve, the tangent to which, at any point, is an illumination gradient.

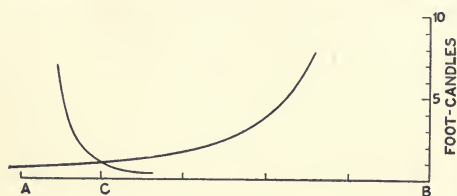

FIG. 88.

Let AB, Fig. 88, be a photometer bar of the old-fashioned type with a single candle at A and 16 candle-power at B. At the point C, one foot from A, the candle will produce an illumination of 1 foot-candle, and at the same point the 16-candle-power lamp will produce the same illumination. The whole essence of ordinary photometry is to discover this point C at which the illuminations are equal, and thus to calculate

the ratio of the candle-powers. The curves are curves of illumination; the ordinates are in foot-candles. The gradient of illumination at C due to the 1 candle is 2 foot-candles per foot, and that of the 16-candle lamp is half a foot-candle per foot.

The Limitation of the Law of Inverse Squares.—This law is true only when the dimensions of the source of light are so small compared with the distance as to be negligible. It may be shown mathematically that when a source of light is an indefinitely long line, the illumination produced by it on a surface facing it is inversely as the distance of the surface from the line. So long as approximately equal lights are compared on a long photometer, the departure from the law of inverse squares is far less than the errors of observation, but cases may arise in which the departure cannot be neglected.

Let AB, Fig. 89, be a straight slender incandescent filament, and P the screen of a photometer. The extreme parts of the filament near A and B have less effect than the parts near the middle O for three reasons. They do not face the screen P, but are inclined to it. The light per unit length emitted towards P is therefore proportional to the cosine of the angle APO. Further, the light from these extreme parts does not fall perpendicularly on the screen, but strikes it at an angle; the illumination received is therefore proportional to the cosine of APO. Again, AP being greater than OP, the illumination at P due to light from A is reduced inversely as the square of AP. Similarly with a source of light presenting a luminous surface to the photometer, the parts remote from the photometric axis are less effective than those near the axis. The illumination is due to the combined effect of the whole. This is exactly the reverse of the \cos^4 relation discussed in Chapter III. p 33. If this problem is pursued it takes refuge in an

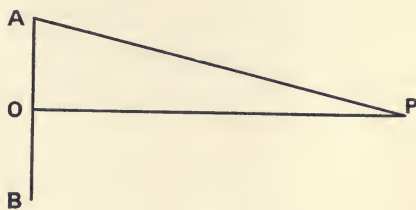

FIG. 89.

integral.* Several mathematicians have gone in after it. Hyde,† with dextrous use of formidable calculations, has attacked the special case of a Nernst filament of appreciable diameter; Fleming‡ has wrestled with it and has produced a convenient formula; S. P. Thompson§ has made a flank assault by an electrostatic analogy, and gives an approximate rule, but no books on photometry have treated the matter from a practical point of view.

Fleming's formula is the least troublesome, he gives it as a correcting factor

$$\frac{1}{2}(\cos^2 \phi + \phi \cot \phi).$$

Here ϕ is the angle APO expressed in radians. For example, let APO be 8 degrees. $\cos \phi$ is 0.9903 and $\cos^2 \phi$ is 0.98069. In radians 8 degrees is 0.1396 and $\cot \phi$ is 7.1154, and the value of the factor is 0.9868. Here $\cot \phi$ is the distance OP when OA is unity. In other words, when the distance of the photometer screen is $3\frac{1}{2}$ times the length of the filament AB, the illumination is $1\frac{1}{3}$ per cent less than if the light had been emitted from an indefinitely small luminous point.

Hyde considers another simple case when the source of light is a disc, and shows that the illumination at the photometer is

$$\pi i \frac{a^2}{a^2 - l^2}$$

where i is the intensity of light per unit area, a the radius of the disc, and l the distance between the centre of the disc and the photometer screen. The curves in Fig. 90 give the results of Fleming's formula for a filament, and of Hyde's formula for a disc within practical limits. The vertical scale is a scale of percentage variation from the law of inverse squares, the horizontal scale is a scale of distance from the photometer; the length of the filament in one case, and the diameter of the disc in the other, being taken as unity.

* Basset Jones, "The Mathematical Theory of Finite Light Sources," *Trans. Ill. Eng. Soc. New York*, iv. 216 (1909) and v. 281 (1910).

† E. P. Hyde, *Bulletin Bureau of Standards*, Washington.

‡ J. A. Fleming, *Proc. Phys. Soc.* xix. 212, and *Phil. Mag.*, Aug. 1905, 212.

§ S. P. Thompson, Presidential Address, *Ill. Eng. Soc. The Ill. Eng.* ii. 824 (1909).

The filament and disc which have been considered lie in one plane, but practical sources of light have some thickness. If instead of having a filament giving 10 candle-power at 4 inches from a photometer screen, we take two filaments each giving 5 candle-power, placed one at $3\frac{1}{2}$ inches and the other at $4\frac{1}{2}$ inches, the illumination will be 1.55 per cent greater, or in the proportion of $\frac{3\cdot5^2 + 4\cdot5^2}{2}$ to 4^2 . The difficulty is then to determine what is the mean position of the lamp, and the only satisfactory way out of it is to make the distance so great that

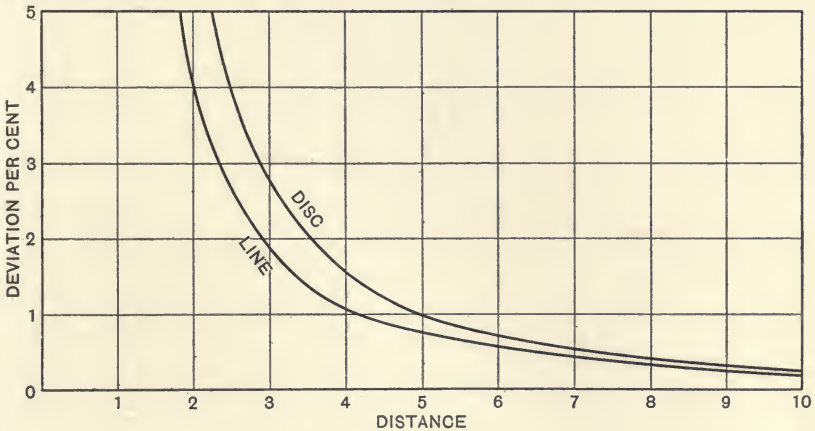

FIG. 90.—DEVIATION FROM THE LAW OF INVERSE SQUARES.

the error is negligible. If the filaments are at $9\frac{1}{2}$ and $10\frac{1}{2}$ inches from the photometer, the error is only one-quarter of one per cent. The error due to the height and width of the source of light is always to reduce the apparent candle-power, and the error due to the thickness is always to increase it.

The Moving-Mirror Method.—As there are marked advantages in avoiding movement of the lamp to be tested, and of the working lamp and the photometer head, it is worth while to consider an arrangement in which all these are fixed, and the principle of the squares of the distance and a carriage running on a bar is retained. The lamp to be measured is placed at L, the photometer head at P (Fig. 91), and the working lamp is placed at W immediately behind the photo-

meter head, as close to it as is convenient, and, of course, well screened from the observer. All these are fixed during work. A pair of mirrors, of good plate-glass, set at 45 degrees, reflect the light from the working lamp into the photometer head. The mirrors are mounted on a carriage which runs on the bar. The broken line represents the axis of the bar or a line parallel to it, and the dotted line represents the path of the light.

The mirrors must be so adjusted that if the photometer head and the lamp to be tested are removed, the image of working lamp *W* appears in the photometric axis, as though it were mounted on the bar. If the mirrors are moved 1 inch, it is as though the working lamp had been moved 2 inches. This arrangement practically doubles the effective length of the right-hand part of the bar, and should prove an advantage in factories where photometer benches take up so much room.

The absorption of light by the mirrors, and indeed their gradual alteration by tarnishing, is of no importance if the

method of double weighing is used. The mirrors may be cleaned whenever the working lamp is cleaned and checked. For ordinary electric glow-

lamps the mirrors may be 4 inches (100 mm.) square. The scale is a scale of reciprocals of squares. The virtual distance of the working lamp *W* from the photometer head is twice the distance d_1 (Fig. 91) plus the distance d_2 (that is the distance between the axis of the working lamp and the photometric axis of the head).

If two workers are employed, one to watch the photometer and other instruments, such as voltmeter and ammeter, and the other to change the lamps and to mark them, the pointer may be attached to the mirror carriage and the scale fixed to the bar with the high numbers to the left and the low ones to the right. The worker at the photometer makes the adjustment of the mirrors by means of a rod, and calls out the readings of the instruments; the other worker reads the candle-

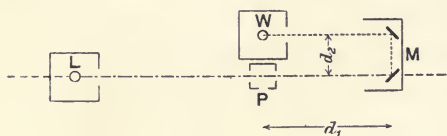

FIG. 91.—THE MOVING-MIRROR METHOD.

power on the scale and changes and marks the lamps. If, however, the photometer worker is to read the candle-power, the scale must be arranged with the high numbers to the right and the low ones to the left, and should be mounted on a light bar carried by the carriage. The index is stationary and may be fixed below the photometer head. In either case the scale must be so set that if the mirrors could be brought up to meet the working lamp W and the photometer head, reducing the distance d_1 (Fig. 91) to nothing, the zero would be at a distance beyond the index equal to the distance d_2 .

Where two workers are employed, the lamp to be measured may be placed behind the photometer head (at W , Fig. 91) and the working lamp at L . A simple scale of squares must be used in that case, and the illumination of the photometer field is constant.

This arrangement of mirrors has been used in an illumination photometer by Martens,* and by Dyke.†

The Construction of the Bar and Scales.—The scales of old-fashioned gas photometers were perhaps as inconvenient for reading as it was possible to arrange. The graduations were fine and the characters stamped in faint black, or worse still, red on a polished brown wooden bar; or, what was hardly any better, a boxwood strip expensively inlaid in mahogany. These photometers were an assemblage of apparatus of different kinds, including meters, pressure gauges, thermometers, governors, candle-balance, and other accessories, a remarkable feature being a great elaboration of cabinet work and velvet curtains. To-day the word photometer has a much more restricted meaning. The German fashion is to engrave the scale on a metal tube or on a strip of metal fastened to a tube. A pair of tubes constitute the bar. The tubes begin by being lacquered with a black varnish, but this soon wears off, and a troublesome reflection of light is the result. A wooden bar, at least 3 inches (say, 75 mm.) deep and $\frac{3}{4}$ inch (20 mm.) thick is as good as anything. The back arris should be bevelled and painted dull black to avoid reflected light. Light is liable to fall on and to

* P. 243; *The Electrician*, lvii. 173.

† P. 156.

be reflected at a large angle of incidence from a flat top of a bar. A pair of ledges may be provided for the wheels of the movable carriage. Two wheels may be grooved and run on a rod, and the third may run on a flat (Fig. 92). Or the carriage may run mono-rail fashion, on two wheels on the edge of the bar, the carriage being nearly balanced on them. See Fig. 94.

The best kind of scale is white glass with the graduations and figures etched and blackened: such a scale is used with the

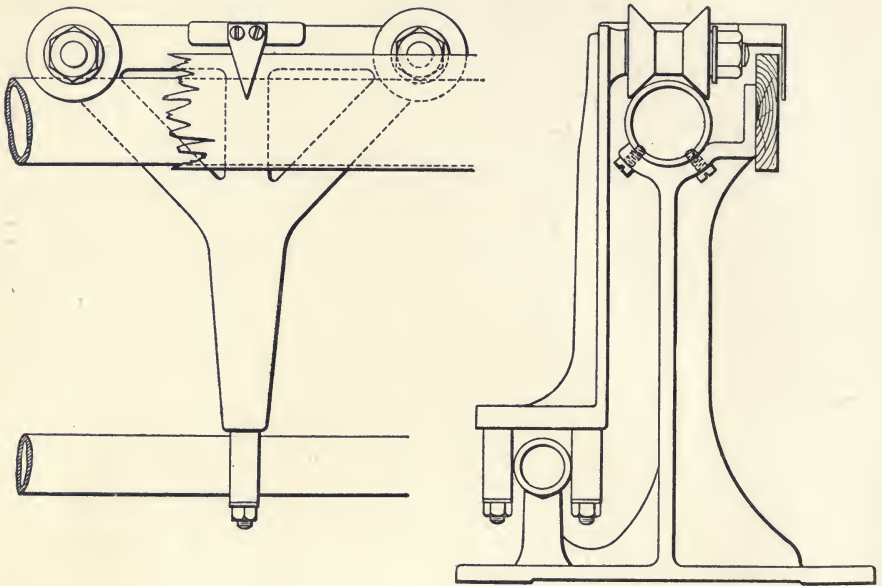

FIG. 92.—EVERETT-EDGCUMBE PHOTOMETER BAR AND CARRIAGE.

Gas Referees' photometer. The next best is a scale painted in black on a ground of white paint, either direct on the bar or on a strip of zinc. The easiest scale to make is on drawing paper, carefully mounted on the bar to avoid distortion and well varnished.

The German method of arranging a photometer seems to be modelled on the laboratory apparatus known as the optical bench. Various optical instruments and fittings are mounted on pillars, and these are erected on slides or carriages which are adjusted on the bench. The Lummer-Brodhun photometer

head is generally mounted on such a pillar, and the lamp-holders are similarly mounted; the lower ends of the pillars drop between the two rods which constitute the bar. There are good reasons for such construction in the case of an optical bench, but none in the case of a photometer for industrial work or for engineers' use.

The photometric axis should not be unnecessarily raised above the bar. Tall pillars need wide bases or carriages, and this entails unnecessary mass and prevents freedom of motion. In order to allow such large apparatus as a Harcourt Pentane lamp to be used, the bar itself need not be extended to the zero of the scale, but plumb-lines can be fixed to represent the plane of zero. The bar may have a removable piece which can be unscrewed or folded back when such apparatus is used. For ordinary work the largest lamp likely to be used will settle the height of the photometric axis above the bar. A height of 5 inches (say 125 mm.) is enough to take a Hefner lamp or a Fleming - Ediswan standard. Electric glow-lamps used as working lamps should be hung downwards, as in that position the filament is not so likely to warp or bend.

Rotating Sectors.—All the photometers described in this book, with the exception of the discrimination photometer of Houston and Kennelly, depend on the balancing of two illuminations by adjusting the distances between the photometer head and the lamps to be compared, and relying on the geometrical law of the squares of the distances. Such confidence may be placed in this law, under ordinary conditions, that the graduation of the scales is a matter of simple calculation, and the construction depending on the adjustment of the distances is of so simple a character that it is not likely to be supplanted for ordinary work. But in certain scientific investigations the range of movement is sometimes inconvenient, and other means are adopted for altering the illumination.

Many different devices have been proposed, such as double or "folding" wedges of grey glass; apparatus depending on the thickness of a liquid like diluted ink, or on the use of polarised light; apertures of adjustable size like the "iris"

diaphragms used in photography ; and so on. Many forms of such apparatus are described by Palaz, while Liebenthal devotes a section of his treatise to methods of weakening the light otherwise than by altering the distance. All these are applicable for scientific investigations, and some of them possess merits for special purposes, but they have not proved to be suitable for industrial photometry of candle-power. Nearly all of them necessitate the use of eyepieces, and they have to be graduated by experiment. One method alone of the mechanical type is worth the attention of engineers.

The use of a rapidly rotating disc provided with apertures has been invented independently by many different workers as a means for reducing or adjusting the light. H. F. Talbot was probably the earliest. In the course of an interesting paper* on various optical experiments, he describes a rotating wheel.

If the wheel has eighteen spokes, each of which is a sector of 10° , their sum is 180° , and therefore a lamp seen through them loses one-half of its light. . . . But since it is requisite to have the power of producing a *variable* obscuration, this may be accomplished by having a second wheel similar to the first, and placed close to it upon the same axis, so that they may be capable of being fastened together in any required position. . . . Positions may be found which will give any precise degree of obscuration that may be desired.

Simple as this method is, it does not follow that the eye will respond to a rapid succession of stimuli and will accept the sum of them in the proportion of the total angular aperture. Talbot's law, as it has been called, has been disputed, and certain experiments † have been adduced to show that the proportion is not constant. But the old masters of photometry were not prone to the mistakes of the hurried workers of to-day. They had time to verify before rushing into print with a paper or a patent. The eye is alone the judge, as Lambert wrote, and the eye is a curious instrument. Nothing but a searching experimental test could prove whether Talbot's assumption was correct. It was unlikely that any serious error

* *Phil. Mag.* v. 331 (Brewster Series, 1834).

† Ferry, *Physical Review*, i. 338 (1893), and Stine, *Photometrical Measurements*, p. 25.

could exist, for adjustable rotating sectors were used in the long researches of Sir W. Abney and Gen. Festing, although much of their quantitative work was not pressed beyond 2 per cent. The matter has been examined by several workers, and has now been set at rest by Mr. E. P. Hyde,* in a research which has probably been unsurpassed in the whole history of photometry for careful attention to experimental detail and theoretical discussion. The probable errors of measurement were all under 0.1 per cent, the average deviation of the observations for any one angular opening was in no case as large as 0.2 per cent, and the observed apparent error in the law of proportionality was about 0.4 per cent, and this was possibly due to stray light under difficult conditions.

The use of rotating sectors may be divided into two kinds. The first is the reduction of a beam of light in a definite proportion in order to bring it within the range of other methods of photometric measurement. This is particularly useful in the case of powerful lights such as electric arcs. It was by the use of this method that I accidentally discovered the rotating phenomenon of the continuous current arc.†

The second method is the adjustable control of a beam of light. In Talbot's original plan the discs had to be stopped, unclamped, readjusted, and restarted for every change of aperture. Abney introduced, and others have independently devised, mechanical arrangements for altering the aperture while the discs are in motion, and his apparatus (Fig. 93) was so excellently made that there was no appreciable back-lash or lost motion of the adjusting lever, and in this easy adjustment lies the secret of accurate photometry and the possibility of good photometry of lights of different colours.

A shaft carries near one end a grooved pulley driven by an electric motor, and at the other end a disc having two openings of 90° . A similar disc is mounted close to this, but free to turn on the shaft. Two pins project from this disc and

* Hyde, "Talbot's Law as applied to the Rotating Sector Disk," *Bulletin of the Bureau of Standards*, Washington, vol. ii. No. 1, 1906.

† Trotter, *Proc. Roy. Soc.* vol. lvi. (1894); and *Cantor Lectures, Soc. of Arts*, 1895, xliii. 973-5.

enter holes in a flange. This flange forms part of a sleeve capable of sliding on the shaft. A quick-pitch screw groove is cut in the shaft, and a pin in the sleeve engages in this groove. The sleeve is provided with a grooved wheel, and a pin attached to a lever engages in the groove. By means of this mechanism the relative position of the two discs may be

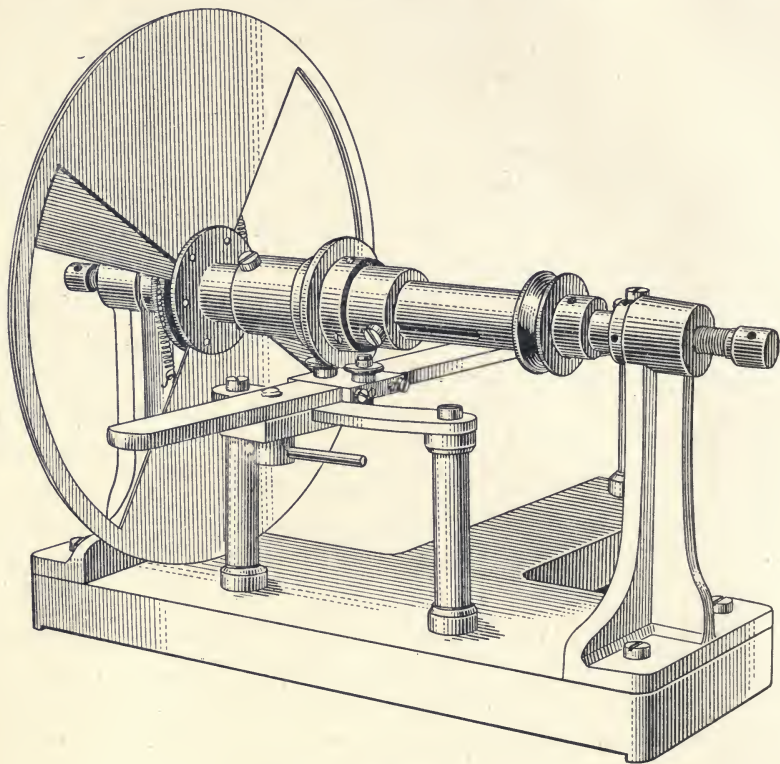

FIG. 93.—THE ABNEY SECTORS.

adjusted while they are in rapid rotation. The lever carries an index which moves over a graduated scale.

The Milne Paddle.—J. R. Milne of Edinburgh has designed several forms of wheels having blades or paddles for cutting off light. The whole wheel and its motor is mounted to turn freely on a vertical axis.

The Lampholder.—Care must be given to the arrangements provided for setting the movable lamp or the photometer head

to the index which points to the graduations on the scale. Two plumb-lines of fine wire are sometimes used, one about six inches in front of the bar, and another at about the same distance behind it (Fig. 94). The lamp is brought into line with these and with the index. In the case of an electric glow-lamp, it should be run at a dull red; it is then easy to see the plumb-lines without being dazzled. It is customary to adjust the lampholder carefully with its centre over the index, and to leave the lamps to accommodate themselves to the holder,

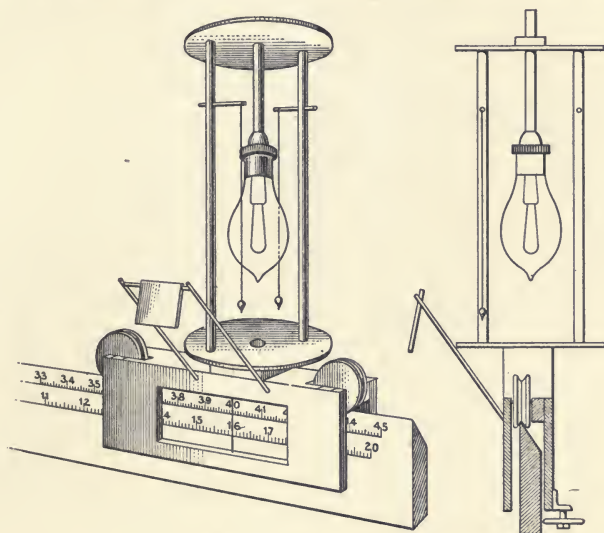

FIG. 94.

merely taking care that they stand or hang vertically. In dealing with large numbers of lamps there is no time for accurate adjustment, nor would it be worth while.

But in investigating any particular lamp, or in setting a standard lamp for the adjustment of the working lamp, care should be taken to set it exactly over the index. When an electric glow-lamp with a looped filament is used, the centre can only be estimated by the eye. When a simple U or hair-pin filament is used it may be set with considerable accuracy either with reference to the scale or to some part of the photometer head.

For such work it is desirable to avoid the uncertain contacts of a bayonet lampholder. Wires should be soldered to the base, and the lamp should be firmly held in a collar or sleeve with a spring or screw.

Observation Recorder.—When an observer having no assistant is engaged in making repeated readings, say in sets of ten for averaging, much time can be saved by recording the settings graphically, instead of taking readings of the scale,

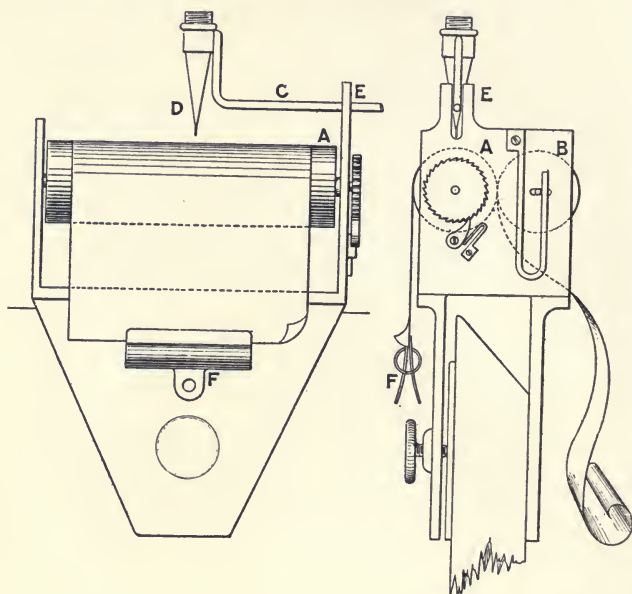

FIG. 95.—OBSERVATION RECORDER.

writing these down, and taking the mean. An arrangement for making such records is shown in Fig. 95.

A roller A, covered with india-rubber and provided with a ratchet wheel, is mounted in a carriage which can be clamped to the bar. The axis of the roller is parallel to the photometric axis. Another roller B is pressed against the first by springs, as in a type-writer. The length of the rollers depends on the kind of work to be done, in general a length of about three inches is convenient. A steel wire C is attached to the movable carriage of the photometer. This wire carries a needle or

pencil or stylographic pen D, and is guided by the jaws E. The needle or pen is held near to but not touching the roller A, either by the stiffness of the wire, or by a spring support on the carriage. A long strip of paper is passed up between the rollers, and hangs down over the roller A, and is loaded at the end with a paper clip F. Hanging free in this way, the ink is given time to dry. A third roller is apt to cause blots, and hides the record.

The movable carriage of the photometer is set approximately at a balance, and the roller carriage is set so that the pen is approximately over the middle of the roller A. The roller carriage is then clamped to the bar. The index is set successively to the two larger divisions of the scale on each side of the approximate setting and the needle or pen is depressed, making two marks on the paper. The paper is pulled forward one step and the marks are repeated, together with marks corresponding to the intermediate divisions of the scale. The paper is pulled forward a step or two, and the photometer is adjusted. After each setting the pen is depressed and the paper pulled forward one step. At the end of a group of settings the scale marks are repeated. Fig. 96 is reproduced from an actual record. It represents the portion of the scale between 1.1 and 1.0; the mean is 1.07 and is the zero reading of the test of angle errors given on p. 96.



FIG. 96.—RECORD.

Such dots do not, of course, form an objective measurement as in an automatic recording instrument, they merely register the settings of the photometer, those settings being based on the judgment of the observer. The saving of time is very considerable. There is no need to turn up the light, or to use a mirror for seeing the scale, no need to read or write down or add up figures. A line may be ruled by eye through the dots to give the mean, and the best position of this line may be judged by holding a fine wire or hair over them.

This recording device may, of course, be elaborated by providing a key or lever which will depress the pen, and on

rising feed the paper on one step. I find that needle pricks are inconveniently small, pencil dots are not uniform, and that the point section of a stylograph pen works very well.

Screens and Stray Light.—The traditions that the walls and ceiling of a photometer room should be painted dead black was shown to be a delusion by Mr. E. P. Hyde.* It is possible that such a dismal precaution might be useful in certain optical researches, but it is the wrong way to set about the prevention of errors due to stray light, and may be said to be a roast-pig way of securing a dark background.

Screens for photometric work may be divided into two classes, one for absorbing or stopping stray light from falling on the interior of the photometer head, and the other for preventing distraction of the observer's sight. In describing his photometer, Bouguer insisted on the importance of screens. In most modern text-books they are entirely disregarded.

An absorbing screen, preferably of black velvet, should be placed behind the lamp under test; a small one will suffice if other suitable stopping screens are used. Even black velvet reflects 0.4 per cent.† It is not essential that such an absorbing screen should be placed behind the working lamp. When this is set at a fixed distance from the photometer head it is sometimes convenient to make a small adjustment of its candle-power by placing a white or grey screen behind it.

In general it is customary for both the lamp under test and the working lamp to be more or less enclosed in a box, unless the former is surrounded by mirrors or other arrangements for dealing with the whole light emitted. Some ventilation is necessary, and any kind of flame lamp must be thoroughly ventilated.

In electric lamp factories where several photometers are arranged in an open room, the whole of each bench is generally more or less boxed in. For arc-lamp work a large partition shutting off part of the room is generally used, suitable openings being provided for working.

* Hyde, "The Use of White Walls in a Photometric Laboratory," *Bulletin of the Bureau of Standards*, Washington, No. iii. p. 417.

† Sumpner, *Proc. Phys. Soc.* xii. 19 (1893); and *The Electrician*, xxx. 381.

If the observer could place his eye at the screen of the photometer he could form some opinion whether the light received there came from the lamp alone, or if any were reflected from other objects. With a Ritchie wedge photometer of the mirror type, or one provided with totally reflecting prisms as used by Dr. Drysdale, an inspection of this kind can be made by removing the translucent screen and looking into the photometer. With a perforated-screen photometer there is a clear way through the axis, and either lamp can be examined through the hole. With other kinds of photometers a small piece of plain glass or a mirror mounted on a handle in dentist's fashion may be held in the photometer head. But the light coming from the lamp is so blinding that faint stray light cannot be estimated. A small black screen so shaped and placed that it will just hide the lamp when viewed in this way, enables a useful inspection to be made. When such small screens are placed in front of each lamp, either close to them or near the photometer head, any illumination of the photometer field is due to stray light.

Stray light may be of several kinds; it may be reflected from badly arranged screens, or from walls or ceiling, or from parts of the apparatus, outside or inside the photometer head, or, except in the case of photometers where the observer is obliged to look through a telescope, stray light may fall over his shoulder on to the photometer. The subject must be dealt with by common sense; the object is to avoid error. Mr. Hyde found in a room with white walls that with a suitable set of perforated screens on each side of a photometer, the other side being nearly surrounded by large screens, when a 32-candle-power lamp was used, the reflection from the walls was equivalent to 0.003 candle-power at the position of the 32-candle-power lamp, causing an "error" of one part in 10,000.

If any part of the apparatus is suspected of producing error by stray light, it is better to stop such light temporarily and try whether it has any appreciable effect on the photometer readings before going to any great trouble in altering the

arrangements to get rid of it. It is quite unnecessary to try to make the room as dark as a photographic dark room.

Perforated screens or diaphragms should be arranged on the following principle. Let AB (Fig. 97) be the extremities of a lamp, and CD the extremities of the field of a photometer. Light from AB is to be allowed to fall on CD in such a manner that a full view of AB may be obtained from any part of CD, but all other light from AB is to be stopped. The lamp AB is surrounded by an enclosure. In this a hole must be cut, slightly larger than AB. Let E be the first screen. A penumbral cone of rays will fall on it, and the screen must be rather larger than its base FF. This screen must have a hole rather larger than enough to allow the rays

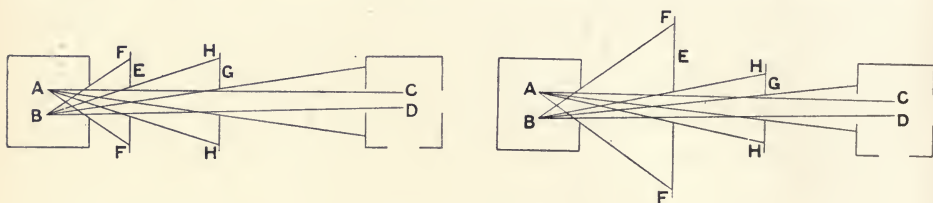

FIG. 97.—SCREENS.

AC and BD to pass. A penumbral cone of rays will fall on the second screen G, and this must be rather larger than its base HH. Finally, the light falls on the side of the photometer head and passes through a hole in it which should be rather larger than CD. If it is smaller than CD it will cast a shadow which is not agreeable. The screens should be crowded together towards the light in order to prevent excessive dimensions. In the left-hand diagram a pair of similar screens are shown, properly placed. In the right-hand diagram a pair of screens are placed uniformly. The screen nearer the light has to be very large.

It is easy to see whether the screens are large enough or are set close enough together to prevent light straying into the room, but it is not so easy to ensure that no part of the lamp is cut off by the holes. Any error from this cause may be very serious. An inspection should always

be made for this, either by direct view or by an inspecting mirror.

The problem may be regarded conversely. If AB is the photometer screen, then nothing but black screens can be seen from AB except through the opening in the box surrounding CD. But if the screens are crowded towards the photometer instead of towards the light, much stray light will spread into the room.

When many screens are used, some provision must be made for the motion of the lamp or of the photometer head, or of the mirrors, if the lamps and head are fixed. A lazytongs set of levers is sometimes used for this purpose, but it is a rather clumsy arrangement.

Cylindrical screens are, in general, a mistake, diaphragms are always needed in addition, to cut off the light reflected from their surfaces. They are, however, useful in some kinds of experimental work. Dr. Paul Kruss suggests that the photometer head should be provided on each side with a tube containing a number of blackened screens pierced with suitable apertures. This would perhaps be sufficient to prevent stray light from entering the photometer, but the observer would have to be shielded from the lights also.

Stray light falling on the translucent screen of a Rumford, Foucault, Gas Referee, Ritchie mirror, or Joly photometer will produce no actual error, but will tend to reduce the precision. With a Ritchie wedge, Conroy, or perforated-screen photometer, a wide tube may be fixed in front of the photometer head, if it is to be used in a room in subdued daylight. High precision is not possible under such circumstances.

One further use of screens must be noticed. For good work, it is necessary that no stray light either through chinks in the enclosures of the lamps, or reflected from bits of bright metal work should reach the eye. It is also desirable that the whole field of view, except in the photometer field, if not quite dark, should be symmetrical. A dark curtain behind the photometer head is useful, and some workers prefer a curtain in front with a hole through which the photometer may be

seen. This is used in the Gas Referees' arrangement. It is not easily applicable to a moving photometer head. "I almost always look at the images themselves," writes Bouguer,* "through a hole made in another diaphragm which I apply at some distance from the eye, and which hides every other object."

It is worth while to take some care in arranging the screens, and stout card or thin board is perhaps better than velvet, since the position of the holes can be adjusted more exactly. It is sometimes convenient to hang them from a rail, and thus to keep the bar free for the moving carriage.

Dead Black Paints.—Such screens, and all visible parts of the photometer except the scale and the actual screens in the photometer, should be painted dead black. A common recipe for dead black varnish is a mixture of lampblack with shellac dissolved in alcohol. But if there is enough shellac to prevent the lampblack from rubbing off, the surface will generally be shiny. Varnishes sold by photographic dealers are seldom dead black. A good recipe is given in Spon's *Workshop Recipes*. Mix lampblack and jannener's gold size into a paste, and continue to add lampblack until it is as stiff as putty; the less gold size the better. Then thin with turpentine. This holds well to metal. A good paint for wood or card may be made on the same principle by mixing lampblack with hot carpenter's glue, adding lampblack until the mixture (which should be kept hot) is very stiff. Then thin with hot water. It may be used hot or cold.

The Control of Electric Glow-Lamp Sub-standards.—The electrical measurements necessary in connection with glow-lamp sub-standards present some difficulty except in well equipped electrical test-rooms. Either the electric pressure or the current must be measured. A potentiometer suitable for this purpose would cost from £25 to £30, but it is possible to use electric sub-standards without such an outlay. For prolonged work with a standardised glow-lamp, a special battery of accumulators is necessary, but for setting a working lamp, it is possible to use the local supply by waiting for a

* *Traité d'optique*, p. 15.

favourable moment. When lamps of the same kind are to be compared, small variations in electric pressure will affect them similarly. But if gas or other flame lamps are to be measured, a battery or a good electric regulator will be required. If a battery is used it is convenient to keep the pressure low.

If it is decided to measure the electric pressure, the holder of the standard lamp should be doubly wired, one pair of wires being used for the supply, and the other for measuring.

Fig. 98 A is a diagram of the necessary equipment for measuring 60 volts. The supply is given at A and B. The current is regulated by the adjustable resistance C. A suitable galvanometer G, a Weston cell W giving 1.0184 volt, and a double key K are provided, and three resistances, one, R_1 , of 58.982 ohms, another, R_2 , of 1.0184 ohm (making together with the first resistance 60), and a third,

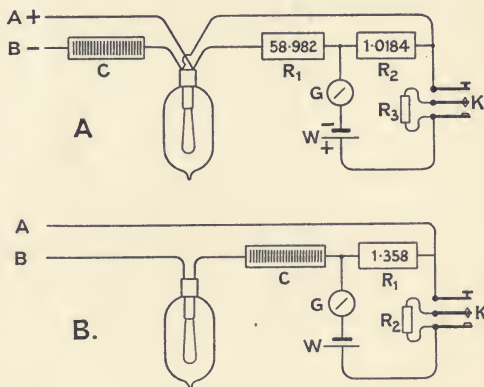

FIG. 98.

R_3 , of a few thousand ohms. A light pressure on the double key completes the circuit through the high resistance R_3 which saves the cell from injury in case the lamp is not switched on. An approximate adjustment of the current is made, and the key is then pressed hard down, cutting out R_3 . The electromotive force of the cell is balanced against the difference of potential at the terminals of the resistance R_2 , by adjusting the resistance C until the deflection of the galvanometer is zero.

The measurement of current is easier, and has the advantage that bad contacts do not cause any error if they are constant, and their effects are plainly visible if they are intermittent. Fig. 98 B shows the arrangements for measuring 0.75 ampere. The resistance R_1 is $1.0184 \div 0.75$ and must be able to carry the current without appreciable heating. A straight piece of manganin wire can be easily adjusted to the right value.

To secure an accuracy of a quarter of one per cent of light, the volts applied to a carbon lamp must be correct to 1 in 3000 or the current must be correct to 1 in 2500. With tungsten lamps the current must be correct to 1 in 2500, and with tantalum to 1 in 2750. But with metal lamps the variation of candle-power with voltage is smaller than in the case of carbon filaments. A change of a quarter of one per cent of candle-power of a tungsten lamp accompanies a change of 1 part in 1600 of the volts, and 1 in 1700 in the case of a tantalum lamp.

CHAPTER VII

DISTRIBUTION OF LIGHT FROM A SOURCE

Mean Horizontal and Spherical Candle-Power.—The light to be measured has hitherto been assumed to give the same candle-power in all directions, but such a source is to be found only in the sun, or a star, or a ball from a firework, or in a text-book on optics. It has been assumed that lamps give the same candle-power in all horizontal directions, and other directions inclined to the horizon have been ignored.

It is true that most flames, and all round flames, comply with this assumption, and that incandescent gas mantles in good order enjoy the same symmetry. When the light is emitted in an unsymmetrical or irregular manner, the mean horizontal or the mean spherical candle-power may be estimated by a single measurement by means of certain devices, or a number of measurements may be made and the mean may be calculated from them. The methods of single measurement tell nothing about the distribution of light, and the study of the mode of distribution of light, involving a considerable number of measurements, gives no general result without calculation of the mean.

The Horizontal Distribution of Light from Electric Glow-Lamps.—The ordinary carbon glow-lamp, whether having a single loop or three or four loops, gives out light in a very erratic manner. Some parts of the filaments hide other parts, but a more important cause of irregular distribution is due to the action of the glass bulb as a concave mirror. If the distance between part of the filament and part of the bulb happens to be about one-half of the radius of curvature of that part of the

bulb, a beam of light is thus focussed and emitted in one direction, Fig. 99. If a lamp is slowly rotated at a little distance from a white screen, streaks due to such beams can

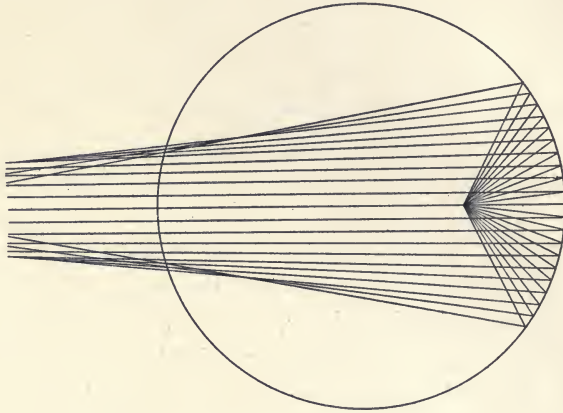

FIG. 99.—REFLECTION FROM BULB.

be seen. Other streaks, dark or bright, may be due to shadows of the filaments or to irregularities in the glass. In general, neither the bright nor the dark streaks are important, and if

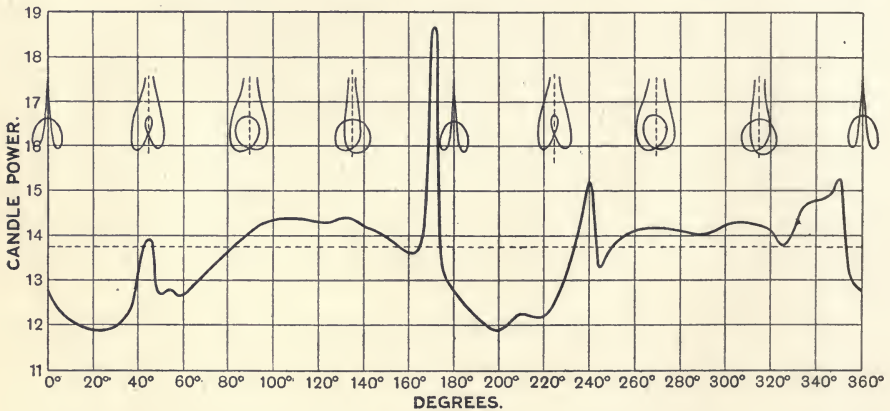

FIG. 100 A.

they could be neglected, a fair horizontal measurement might be made. But there is a risk that one of them might fall on the photometer and cause serious error.

If the lamp is turned round step by step on a vertical axis, and the candle-power is measured in different directions, the results may be plotted with rectangular co-ordinates, Fig. 100 A, or as a polar curve, Fig. 100 B.*

Mean Horizontal Candle-Power.—The mean horizontal candle-power of a glow-lamp may be calculated by taking the average of a considerable number of horizontal measurements, or of a number of ordinates of such a curve as Fig. 100 A, or of the radii of such a curve as Fig. 100 B. The dotted lines in these figures show the mean horizontal candle-power from such calculation.

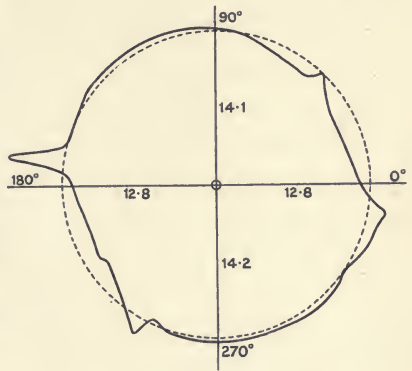

FIG. 100 B.

Wild arranges eight inclined mirrors in a horizontal frame. The lamp is mounted in the centre, and below it a large mirror set at a slope of 45 degrees directs the light to a photometer. From the photometer eight different views of the lamp are seen at a time as shown in Fig. 101, together with the end view of the lamp which is generally hidden by a screen. With metallic filament lamps having four or eight loops, these may hide each other. The horizontal frame on which the eight mirrors are mounted is capable of rotation through a small angle, either for the purpose of obtaining eight different typical views, or by taking a second or third measurement, of obtaining the mean of sixteen or twenty-four different views. Allowance is of course made for the mirrors by measuring a lamp directly in eight different positions.

The usual way of measuring the mean horizontal candle-power of an electric glow-lamp, is to spin it on a vertical axis, so as to present each aspect in turn to the photometer. This would give an intolerable flicker if the lamp were revolved

* A. Russell, *Journ. Inst. Elect. Engs.* xxxii. 634-6. See also G. B. Dyke, *Proc. Phys. Soc. Lond.* vol. xix.; and *Phil. Mag.* January 1905.

slowly, and would cause the filament to be distorted by centrifugal force if the speed were high, thus altering the arrangement of shadows and of streaks which have been mentioned.* With a carbon lamp there is a risk of bringing the filament into contact with the glass, which would cool it and alter the candle-power, or might crack the glass and ruin the lamp. Metallic filaments being even more fragile would suffer more than carbon were it not that careful arrangements are generally

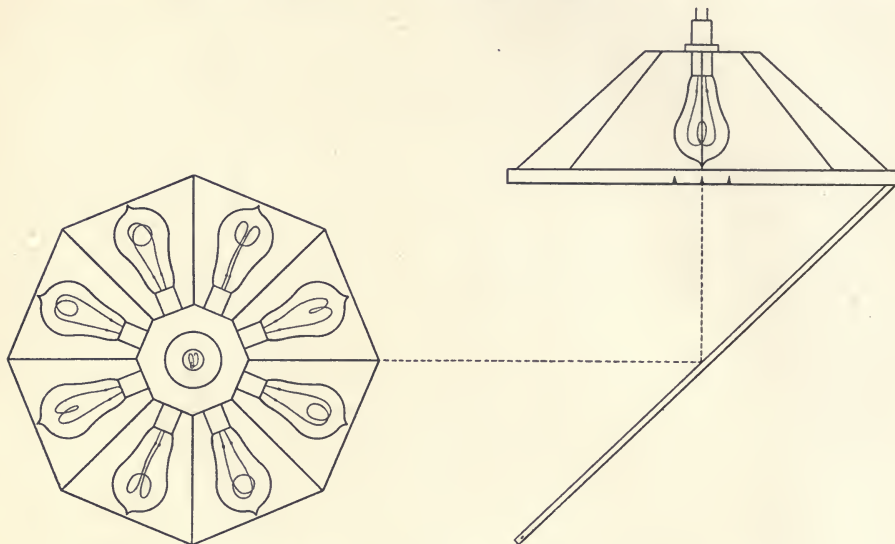

FIG. 101.—WILD'S MIRRORS FOR MEAN HORIZONTAL CANDLE-POWER.

made for supporting them. In order to get rid of serious flicker a lamp must spin at not less than 180 revolutions per minute. A speed of 200 is usual; some lamps will stand a speed of 500 or 600 revolutions per minute.

If it would suffice to view a lamp from three directions 120 degrees apart, two mirrors might be set as in Fig. 102 to reflect the light into the photometer. Allowance would have to be made for the increased length of the paths of the reflected beams, and for the absorption of light by the mirrors. Were it

* See E. P. Hyde and F. E. Cady, "On the Determination of the Mean Horizontal Intensity of Incandescent Lamps," *Bulletin of the Bureau of Standards*, Washington, vol. iii. No. 3 (1907).

not for the intense beams and sharp shadows which are present in many electric glow-lamps, this plan would generally suffice. But though it is for this reason not practicable, it is evident that with the help of such mirrors the lamp may be spun at one-third of the speed. The direction in which the auxiliary mirrors are placed is of no importance. A single mirror, as in Fig. 103, enables the speed of rotation to be reduced to one-half.

Complication in graduating the photometer scale would be required if the photometer head were to be moved, but by the use of a movable working lamp an ordinary scale can be used. An electric motor is generally employed to spin the lamp. Great care must be given to the sliding contacts. Another plan is to hold the lamp fixed, and to spin two or more



FIG. 102.—AUXILIARY MIRRORS.

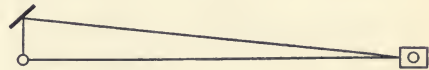

FIG. 103.—AUXILIARY MIRROR.

mirrors round it on a horizontal axis. Metallic filament lamps, having a considerable number of loops nearly parallel with the axis of the lamp and nearly equidistant from it, often give both bright and dark streaks no less marked than in the case of a single-looped carbon filament.

The Distribution of Light from Glow-Lamps and other Lamps.—To measure the candle-power at different angles with the horizon, the lamp may be held at the required inclination, taking care that the centre of gravity of the filament remains fixed relatively to the photometer bar. It is sometimes more convenient to leave the lamp in the upright position and to use mirrors. These must be used for testing electric arcs or gas-burners. Many different arrangements of mirrors have been suggested. The investigation of the distribution of light from a lamp as modified by reflectors or shades is of considerable practical importance. Candle-powers of glow-lamps at different angles with the horizon plotted with polar co-ordinates

are nearly all of the same character. A specimen is shown in Fig. 104.* The position of the filament is indicated by the sketch at the centre. The light is entirely obscured in the upward direction by the lampholder, and the candle-power is comparatively small downwards because the filament is for the most part "end on." A curve is drawn through the observed points on the right-hand side of the diagram, and a circle is drawn on the left-hand side, satisfying most of them, and showing

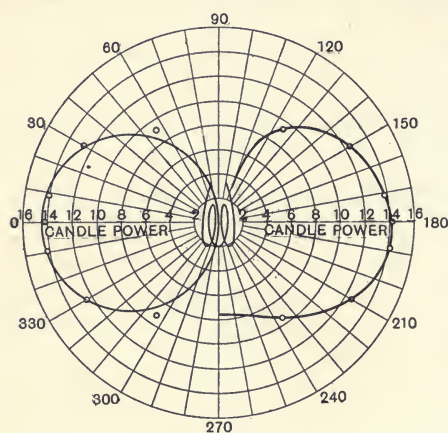

FIG. 104.

that the candle-power varies approximately as the cosine. The distribution curve of an inverted gas mantle is closely approximate to a semi-circle.

The Distribution of Light from Arc Lamps.—Nearly all the light from an ordinary continuous-current arc lamp is emitted from the end of the upper or positive carbon. This end generally becomes hollowed, forming a crater,

but the effect is the same as though it were flat. If no light were obstructed by the lower or negative carbon, the candle-power would be greatest in the downward direction, would be less and less in directions inclined to the vertical, and would be nothing horizontally. Polar curves representing the candle-power of arc lamps were well known, but the reason for their peculiar shape was not explained until 1892.†

I drew imaginary views of the ends of a pair of carbons seen from different directions. The areas of the ends of the positive carbons drawn in projection on a large scale were measured, and assuming the candle-power to be proportional to the visible part of the area, they yielded a curve closely resembling the well-known polar curves of arc lamps.

* C. C. Paterson, *Journ. Inst. Elect. Eng.* xxxviii. 302.

† Trotter, "Notes on the Light of the Electric Arc," *Journ. Proc. Inst. Elect. Eng.* vol. xxi., April 19, 1892.

The full line in Fig. 105 is such a curve, representing the mean of twenty-six different arc lamps measured by M. Wybauw* in 1885. The dotted line is a semicircle. There is a fair agreement between the two from 90° to 60° , and below that the light is obstructed more and more by the lower carbon, and from 5° to 0° there is none, in accord with the Japanese proverb,

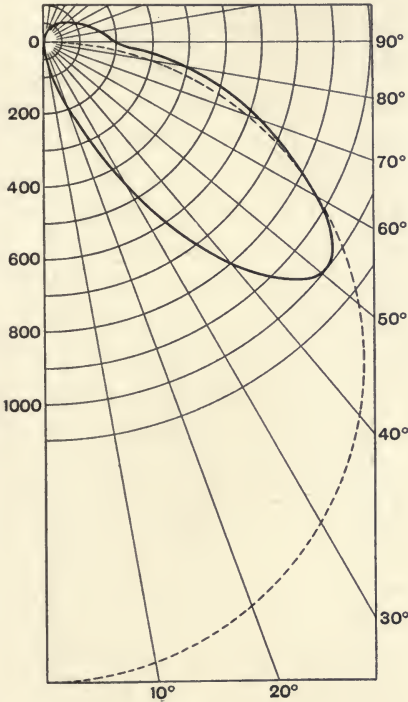

FIG. 105.

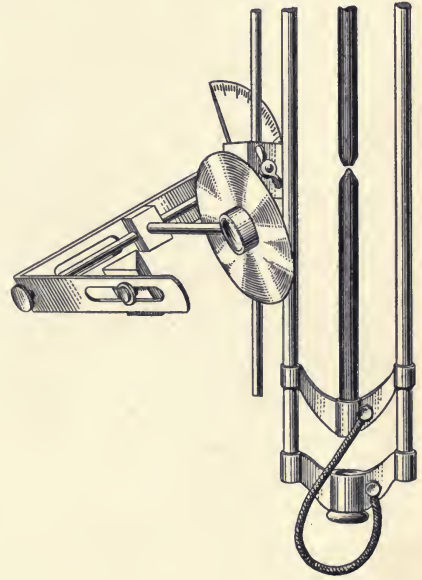

FIG. 106.

Todai moto kurashi—the darkest place is just below the candlestick.

To test this I carried out experiments with the permission of Prof. S. P. Thompson at the Finsbury Technical College, and with the assistance of Mr. C. F. Higgins, who made the apparatus shown in Fig. 106.

An arm, swinging on a horizontal axis fixed in a line with an electric arc, could be set at different angles with the horizon.

* *La Lumière électrique*, xxxvii. 414 and xxvi. 58.

It carried a lens and a mirror set at 45 degrees with the direction of the light falling on it.

The beam was reflected in a direction parallel with the axis on which the arm turned. An image received on a sheet of drawing paper was amplified about twenty-eight times. The outline of the incandescent crater was traced in pencil, the diameter of the carbons forming a standard of measurements. Drawings were made at every 10 degrees inclination. Fig. 107 gives reproductions of some of these drawings.

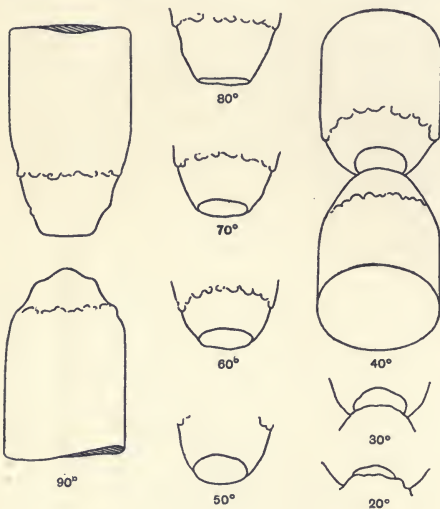

FIG. 107.

degrees, that is, with the arm horizontal, nothing is seen of the crater from which nearly all the light is emitted. From 80 degrees to 50 degrees the apparent area increases as the cosine of the angle. At 60 degrees the area is one-half that of the disc of the crater. But the full view of the disc is never seen, for at 50 degrees the lower or negative carbon begins to interfere, and at 15 degrees nearly all is obscure.

The lens being removed, the light was allowed to fall on a photometer instead of on the sheet of paper. Fig. 108 shows the results. The circles represent candle-power, the black dots represent areas measured on the

horizontal, nothing is seen of

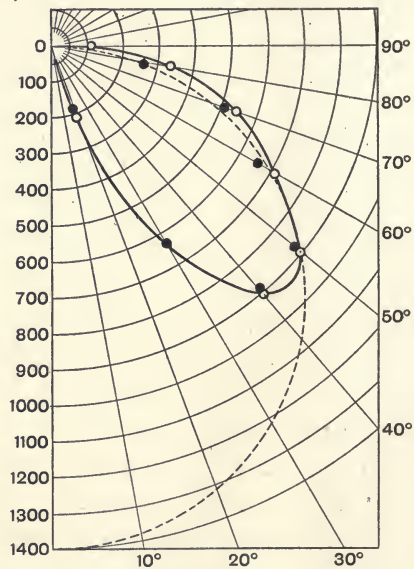

FIG. 108.

drawings. The dotted semi-

circle gives the theoretical result supposing the negative carbon were absent. The image of the crater at 60 degrees, measured by a planimeter, was 20.8 square inches (134.2 sq. cm.); the image of the carbon was 17 inches (431.8 mm.) in diameter. Its actual diameter was 0.6 inch (15.2 mm.); the image was therefore magnified 28.3 times. Fig. 109 gives the relation between candle-power and area. The mirror was of platinised glass, to avoid the double image given by an ordinary mirror. Its reflecting power was not ascertained, and the candle-power values are therefore on an arbitrary scale. This does not affect the result that the areas are directly proportional to the candle-power plus a constant. This constant represents the light emitted from the red-hot parts of the carbons and from the flame.

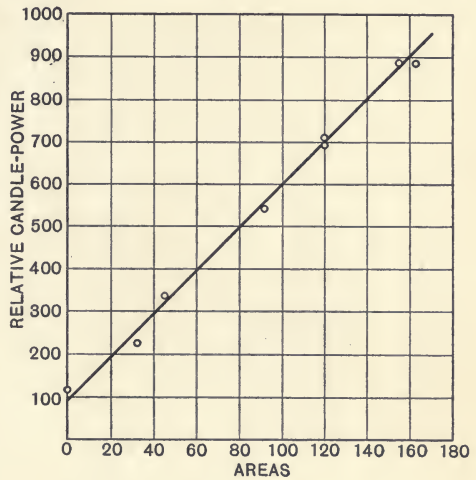

FIG. 109.

Mean Spherical Candle-Power.—The variation of candle-power of electric glow-lamps in different directions is of very little practical importance to the user. Bright streaks on the walls or ceilings count as defects, not as additional light. It is unreasonable to expect such a lamp to give light in the direction of the holder, and not much attention would be paid to mean candle-power but for the accurate descriptions and tests which are necessary in important sales and purchases, especially where tenders are made to stringent specifications, and where competition is keen. The ordinary user of electric glow-lamps is as little cognizant of the computation of mean spherical candle-power, as is the ordinary tea-drinker of the refinements of the expert tea-taster. The idea of mean spherical candle-power, that is, the average candle-power “in all directions,” or in a given number of directions, from points situated on an imaginary

sphere surrounding the light, is easy to grasp in the case of a glow lamp or ordinary incandescent gas mantle, but not so in the case of a continuous-current arc lamp. To begin with, as only an insignificant quantity of light is sent by an arc lamp in directions above the horizon, the mean spherical candle-power is about half of the mean hemispherical, and if the lower half is all that is useful, why disparage the candle-power in this

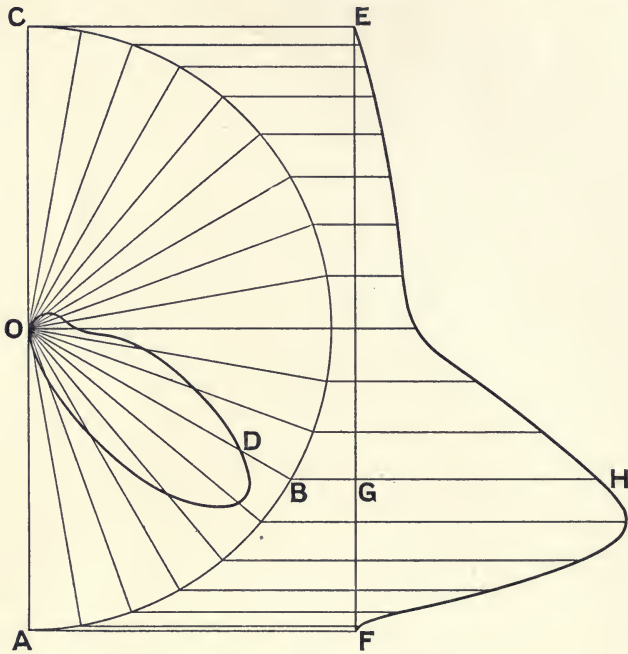

FIG. 110.—ROUSSEAU'S DIAGRAM.

way? Even the mean hemispherical candle-power is not very informative, and for many purposes it is sufficient and vastly less troublesome to find the angle at which the maximum light is given and frankly to call this the maximum candle-power. Blondel strongly advocates the consideration of the total flux of light in "lumens," that is, mean spherical candle-power multiplied by 4π .

Calculation of Mean Spherical Candle-Power and Rousseau's Diagram.—The mean spherical candle-power may be calculated by Rousseau's* method from a polar curve. From the centre

* *La Lumière électrique*, xxxvii. 415.

O, Fig. 110, draw a semicircle ABC large enough to enclose the polar curve. Draw any number of radial lines from O to the circle, such as OB cutting the curve at D. Draw the vertical line EF and the horizontal line BGH. Make GH equal to OD. Through all such points as H draw the Rousseau curve. The area of this curve divided by the length of its base, or the length of its mean ordinate, is a measure of the mean spherical candle-power.

There is an erroneous idea, and one which has been examined and corrected in a very clear manner by Mrs. Ayrton,*

that the area of the polar curve, or the solid contents of its figure of revolution about the axis of the carbons, is a measure of the mean spherical candle-power of the arc. Mrs. Ayrton demonstrated this by Fig. 111. Let OAB be a distribution curve of a certain mean spherical candle-power. Let OCD be another curve of exactly half the candle-power in each direction. Then it must have half the mean spherical candle-power. But the area of the curve OCD is plainly not equal to half the area of OAB, still

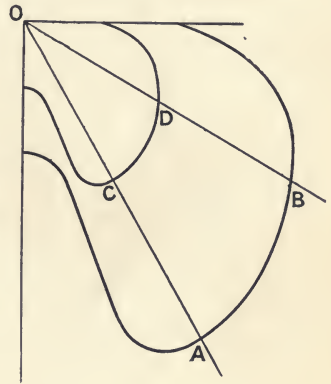

FIG. 111.—FLAME ARC LAMP
(OLIVER "ORIFLAMME").

less would the figure of revolution of the former curve about the vertical axis be half the volume of the figure of revolution of the latter.† Another fallacy which she exposes is the idea that the Rousseau curve simply gives the mean spherical candle-power plotted with rectangular co-ordinates.

Russell's Construction.—Mean spherical candle-power has been defined as the mean of a large number of values of candle-power taken at points situated on an imaginary sphere surrounding the source of light. It is obvious that these points should be uniformly spaced to give a fair mean, or the points should represent the mean candle-power received on equal

* Hertha Ayrton, *The Electric Arc*, p. 454.

† See also Russell, *Journ. Inst. of Elect. Eng.* xxxii. 631.

portions of the sphere. The surface of a sphere, on which lines of latitude and longitude are drawn at equal angles from the pole and round the equator in the usual manner, is divided by those lines into portions which are not of equal area. It is assumed that the distribution of light is the same in all azimuths or horizontal directions or lines of longitude, or, in other words,

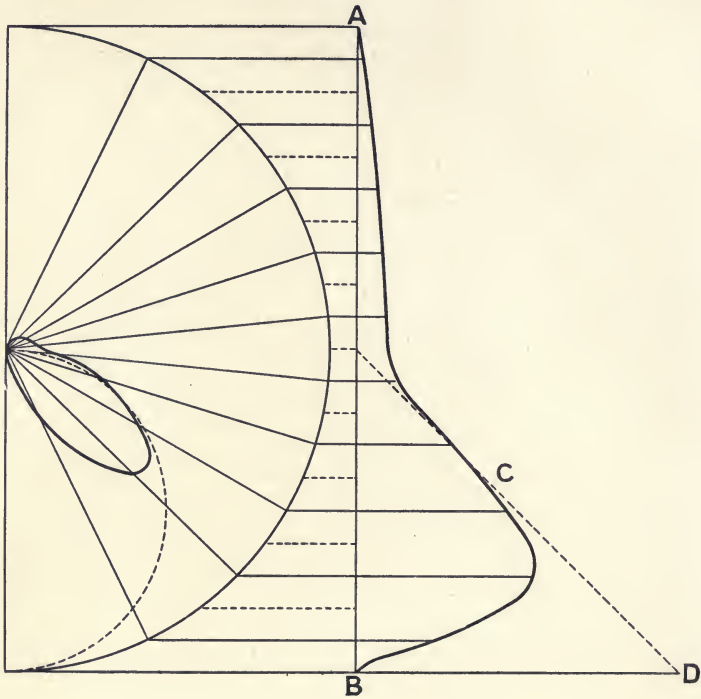

FIG. 112.

that it is symmetrical about the vertical axis. If a polar curve be obtained by making a number of measurements at equal steps of latitude, as in Figs. 105 and 108, too many are made at angles near the vertical. Russell has shown that no accuracy is sacrificed if a comparatively few measurements are taken, provided that they are made at the correct angles.

It was shown on page 55 that, by Archimedes' theorem, the surface of a sphere may be divided into equal zones or belts by the construction in Fig. 112. To divide the surface of a

sphere into 10 equal zones, draw the line AB equal to the diameter, and divide it into 10 equal parts. Drop perpendiculars, represented by the broken lines, to cut the semicircle; these will mark off the 10 required zones. These lines are not required, but through the middle points of these equal parts perpendiculars are drawn, and these mark off on the semicircle the required angles. Radial lines are drawn through these points, and the construction is completed as in Fig. 110, but with 10 evenly spaced ordinates instead of 17, some of which were of little or no use. The dotted semicircle shows what the distribution of candle-power would have been if the light had not been obstructed by the lower carbon. Mrs. Ayrton shows how this may be represented on the Rousseau diagram by the straight dotted line. The area of the figure BCD represents the lost light, and it is instructive to compare this with the part of the polar diagram representing, but by no means proportional to, the lost light. Fig. 113

gives the Rousseau diagram for a Crompton-Blondel arc. Other methods of calculating mean spherical candle-power from the polar curve or from the separate photometric measurements have been

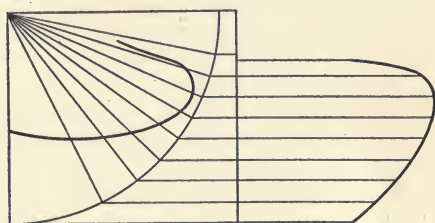

FIG. 113.

proposed by Dr. A. E. Kennelly,* E. W. Weinbeer,† and others.

The Measurement of Mean Spherical Candle-Power.—Suitable arrangements of mirrors, combined in the case of electric glow-lamps with spinning, have been used for measuring the mean spherical candle-power or M.S.C.P., but it is generally sufficient to determine the relation between mean horizontal candle-power and mean spherical candle-power for a few samples of any given type of lamp, and to use this as a reduction factor for all lamps of that type. This factor does not differ much from 0.8,‡ that is to say, the mean spherical

* Kennelly, *The Electrical World*, New York, 1908, No. 13.

† Weinbeer, *The Illuminating Engineer*, Lond. i. 559.

‡ Dyke, "The Mean Spherical Candle-Power of Incandescent and Arc Lamps," *Proc. Phys. Soc.* xix. 399, and *Phil. Mag.*, January 1905, 136.

candle-power is about 0.8 of the mean horizontal candle-power. Fleming* has shown mathematically that for a simple straight filament it is $\frac{\pi}{4}$ or 0.785.

Blondel has described † three methods of measurement of M.S.C.P. In the first, he collects a large but definite portion of the total flux of light by means of a concave mirror, and throws a nearly parallel beam on to a diffusing translucent screen; or he brings it nearly to a focus on a white reflecting screen, and measures the brightness by a suitable photometer. In the second, he encloses the lamp L, Fig. 114, within a

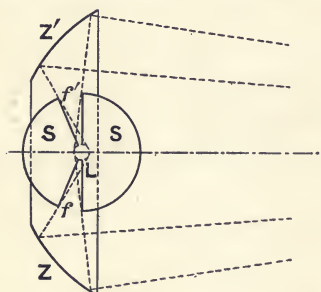

FIG. 114.—BLONDEL'S ANNULAR ELLIPSOIDAL LUMENMETER.

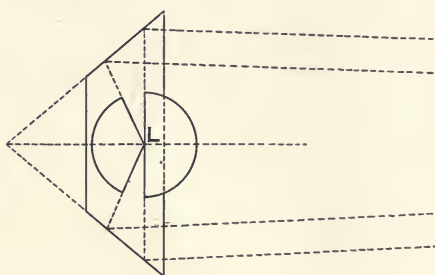

FIG. 115.—BLONDEL'S DIFFUSING CONE LUMENMETER.

blackened globe SS, having two openings of 18 degrees, ff' , and receives the light passing through these openings on an annular ellipsoidal mirror ZZ'. The light is reflected on to an opal glass or paper screen. The third method is to use a white diffusing cone, Fig. 115, instead of the annular mirror. In each of these methods the apparatus is calibrated or standardised by a lamp of known M.S.C.P., the light is directed horizontally, and the photometer is placed at some distance from the reflector.

C. P. Matthews ‡ described in 1901 a method which employs a number of mirrors spaced uniformly round a large semi-

* Fleming, "Ratio between Mean Spherical and Horizontal Candle-Power of Incandescent Lamps," *Phil. Mag.*, August 1905; and *Proc. Phys. Soc.* xix. 208.

† Blondel, "La Détermination de l'intensité moyenne sphérique des sources de lumière," *Comptes rendus*, March and April 1895, and *L'Éclairage électrique*.

‡ Matthews, *Trans. Amer. Inst. of Elect. Eng.* xviii. 680.

circular frame. His first proposal was to reflect the light to a photometer placed at some distance in the axis of the semi-circle; and later* he devised two sets of mirrors reflecting the light back again to a photometer in the axis close to the source of light, and separated from it by a screen. Fig. 116 shows G. B. Dyke's † arrangement of the apparatus as set up in the Pender Electrical Laboratory. A wrought-iron half ring A, 6 feet (1829 mm.) in diameter, carried eleven pairs of adjustable mirrors B, fixed on supports C. The lamp to be tested is mounted at D exactly at the centre of the semicircle and in the plane of one set of mirrors. A Lummer-Brodhun photometer is placed at E; its white screen is set vertically as usual. The plan view at F shows that the case is cut away to permit light to reach the screen from all the mirrors. The photometer is fixed in the plane of the other set of mirrors, and a screen of match-board, K, prevents light from reaching the photometer except by way of the mirrors. The openings in this screen may be closed by slides so that each pair of mirrors may be used separately during adjustment. An independent lamp is not used to balance the photometer, but the horizontal light from the lamp at D is reflected by the pair of mirrors H on to the side G of the photometer. This pair of mirrors runs on a carriage on the bar J.

In Matthews' original first arrangement, which resembles Blondel's apparatus shown in Fig. 114, the light from each mirror fell at a small constant angle on the photometer. The light from the upper and the lower mirrors had to be reduced in proportion to the cosine of the angle on the semicircle, and this was done with smoked glasses. But in the second method followed by Dyke the vertical photometer screen makes this correction. If, however, the screen is not perfectly matt and smooth, or, in other words, if its brightness is not proportional to the cosine of the angle of incidence of light falling on it, the total brightness will not be a true measure of the sum of the beams reflected by each pair of mirrors. The departure from the cosine law must be examined, and corrections made

* *Ibid.* xx. 66.

† Dyke, *loc. cit.*

for each pair of mirrors by altering the lengths of the paths of

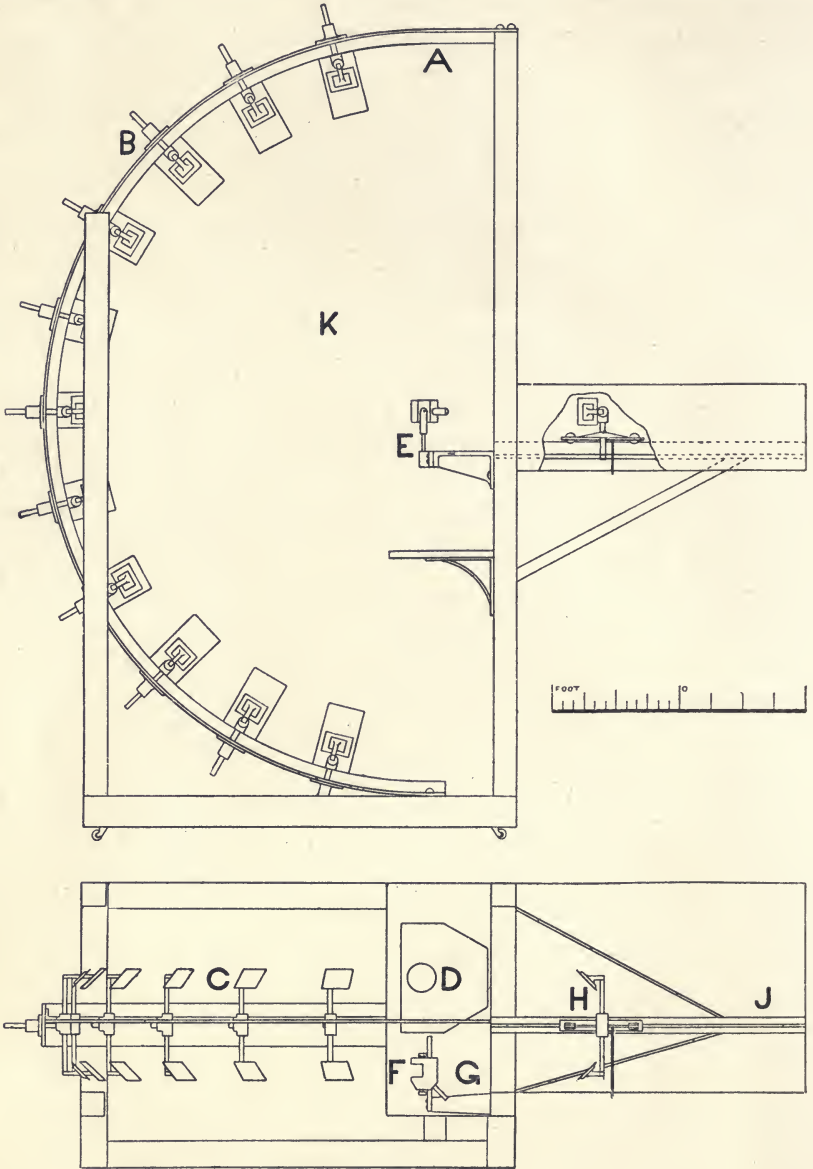

FIG. 116.

the rays. These corrections are fully described in Dyke's paper.

Wild * has adopted a method proposed by M. Leonard † in 1904. He reverts to the method of directing the light to a distant photometer in the axis of a ring of mirrors. The mirrors are not spaced uniformly like those of Matthews, but according to Russell's angles. Instead of using a number of small mirrors set round a semicircle, he uses eight set round in a conical box, the alternate mirrors of the series being placed

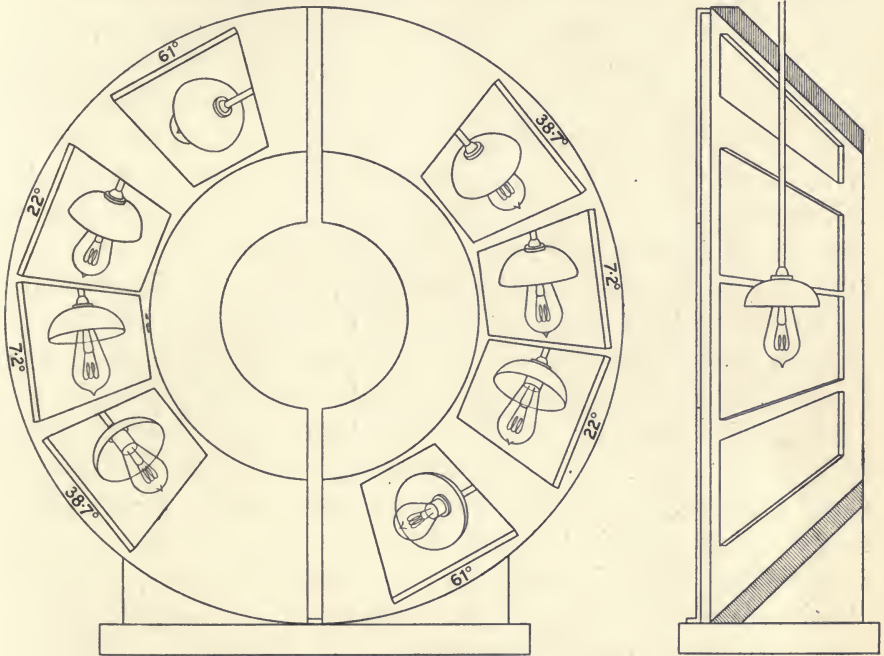

FIG. 117.

on opposite sides. This gives a large field of view, which is necessary if the effect of a shade is to be examined. Fig. 117 shows a front and a sectional elevation of Wild's apparatus. In the former, eight views of the lamp are seen reflected in the mirrors.

Ulbricht's Globe.—Let four triangular white screens be placed together, forming an inverted pyramid or half an octahedron, with the four meeting points immediately below the arc

* *The Illuminating Engineer*, ii. 197.

† *L'Éclairage électrique*, xl. 128.

lamp, and the four edges forming the base of the pyramid level with the arc. These will receive the whole of the light of the lower hemisphere. Remove three of them and the remain-

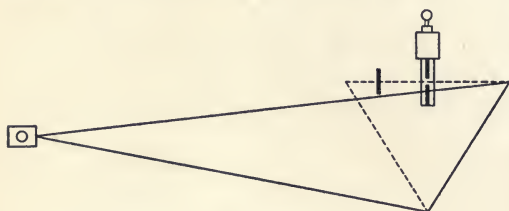

FIG. 118.

ing one receives one-quarter. A photometer is set as in Fig. 118, a small screen shielding the photometer from the direct light of the arc. The actual candle-power could not be ascertained

without many experiments and calculations, but the method of substitution can be employed, and the arrangement can be calibrated by a lamp of known distribution and candle-power. This principle has been extended by Prof. Ulbricht, who uses a sphere whitened inside (Fig. 120). For arc lamps it should be at least 5 feet (1.5 metre) in diameter. A hole at the top allows the lamp to be introduced, and a small window covered with opal or ground glass at the side is illuminated by the reflected light, but is carefully screened from the direct light of the lamp. The brilliance of this window is measured with any convenient kind of photometer, and is proportional to the mean spherical candle-power of the lamp regardless of the distribution of light from the lamp. This has been called an integrating sphere, and a good deal of mathematics has been wasted over it.

Let A, Fig. 119, be a small luminous patch on the inner surface of a short cylinder or hoop ACB. The part of the hoop on the opposite end of the diameter at B will be illuminated by it. Consider a patch at C, the distance AC being, say, one-third of the distance AB. If A were a luminous body emitting light equally in all directions, and if the surface at C

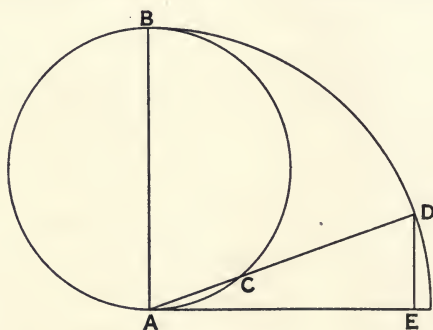

FIG. 119.

were turned to face it directly, the illumination at C would be nine times the illumination at B. But A does not emit light equally in all directions. In the direction AC it emits only one-third of the light, for the cosine DE is one-third of the unit length AB. Again, the surface at C does not face A, but is averted from it and receives only one-third of the light. In consequence of the inclinations of A and C to each other, C receives one-ninth of the light, and the illumination is therefore equal to the illumination at B. Similarly, it may be shown that every other part of the interior of the short cylinder is uniformly illuminated by the small patch at A, and all these other parts will in turn contribute to the illumination of every other part.

If the cylinder is turned round AB as an axis, it is evident that the same condition holds for each part of a globe. Now let a lamp be put into the globe, in any position. The illumination of the surface will consist of two parts, one due to the light falling directly on it, and the other due to reflected light. Let the distribution of the direct illumination be of any kind, however irregular, even if the whole of it falls on A and on no other part, the illumination due to reflection will be uniform all over the surface. If therefore an arc lamp is hung in a large globe, and the direct illumination of any part is intercepted by means of a screen, the illumination in the shadow of the screen will be uniform. This part may be observed through a window, or the window may be covered with opal or ground glass, and may be screened from direct light.

It is usual to paint such globes white, but a high reflecting power is not essential, and may be inconvenient. If the reflecting power is 50 per cent, or one-half, then the illumination due to the second reflection is 25 per cent, and to the third reflection $12\frac{1}{2}$ per cent, and so on; the total illumination due to repeated reflections will be twice that due to the direct light. For any other reflecting power R the total illumination will be $\frac{I}{1-R}$.

The important matter is that the paint should be matt, or

not shiny, in order that there may be no focussing due to regular reflection.

An Ulbricht globe, Fig. 120, must be made to open if only for re-painting, and it is an expensive affair. It must be calibrated by a lamp of known mean spherical candle-power. There is no virtue in the globular form. When repeated reflection is considered, it will be found that a chamber of any convenient shape uniformly painted with a light matt

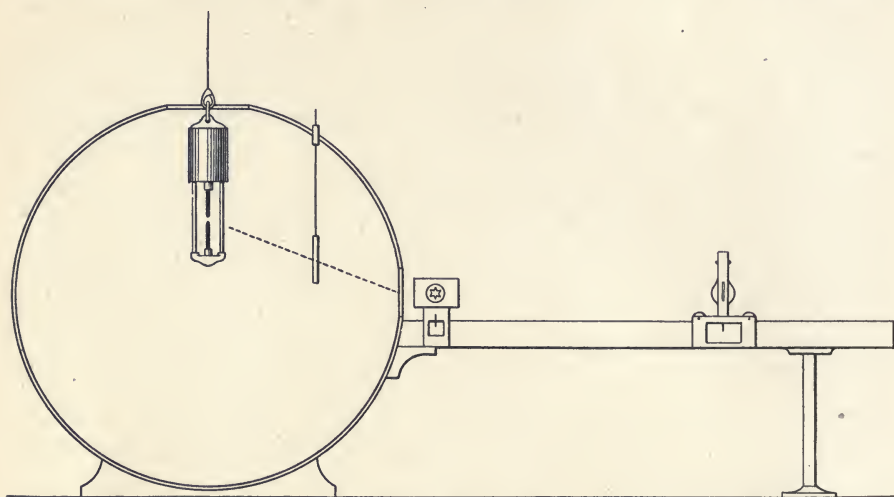

FIG. 120.—THE ULBRICHT GLOBE.

colour will do as well.* This method is useless for gas or oil lamps, owing to the impossibility of good ventilation.

For ordinary practical purposes, a general knowledge of the distribution of the light from an arc lamp and its maximum candle-power is much more important than its mean spherical candle-power, and this latter quantity is only worth measuring by an Ulbricht sphere or some such device when the amount of light produced by different sizes or qualities of carbons, or by different currents or lamps, is to be investigated.

* Sumpner, *The Illuminating Engineer*, London, iii. 323; and *The Electrician*, lxxv. 72; and Rosa, *Bulletin of Standards*, Washington, vi. 562.

CHAPTER VIII

THE PHOTOMETRY OF COLOURED LIGHTS

Introductory.—In the foregoing chapters it has been generally assumed that the colour of the two lights under comparison was the same. Coloured lights may be divided into three classes, depending on temperature or degree of incandescence; on selective emission, such as the greenish tinge of a Welsbach gas mantle, or the violet light of a mercury arc; or on colours due to absorbing screens such as red or green glass. Colours of the first kind range from dull red through various shades of orange yellow; pale yellow to white. The practical range is from the orange colour of the amyl acetate flame of a Hefner lamp to the light of an electric arc.

Little attention appears to have been given to these colour differences due to incandescence, and a definite description of any one colour in terms of temperature of a theoretical "black body" or in terms of the spectrum would be difficult, and of not much practical value to most workers. The number of watts per candle-power of an ordinary carbon glow-lamp offers a good description, and if it is apparently not very precise it is because a small change in colour is represented by a large change in watts per candle.

Mr. C. C. Paterson, who has studied the subject, informs me that on the basis of an ordinary carbon lamp, taking the mean horizontal candle-power and a normal reduction factor, the colour of a Hefner flame corresponds to about 9.5 watts per candle, and that of the Pentane to 6.5 or 7. I find that the difference of colour between a Fleming standard glow-lamp at 4.5 watts per candle and a Pentane lamp, each giving 10 candle-

power, is not enough to cause any inconvenience when a Gas Referees' photometer is used, but the light of the latter is distinctly warmer when a Rumford photometer is employed. An Argand gas-burner is a fair match for the Pentane, but a good paraffin lamp gives a paler light. An ordinary arc-lamp gives a light which by contrast with other artificial lights appears bluish, but in reality when compared with white daylight it is yellowish.* Paterson finds that a tungsten filament at about 2 watts per candle corresponds in colour with a carbon filament of 3 or 3.5 watts per candle.

So long as photometry was confined to the comparison between candles, gas flames, and oil lamps, little or no attention was paid to colour, and it was probably not until about 1880 when electric arc-lamps were being developed, that the colour difficulty arose. From one point of view this appeared unsurmountable, and it was customary to take two sets of readings, one through green glass and another through red. If some definite kind of red and green glass is used, it is possible to derive useful information from such pairs of readings. Macé de Lépinay † suggested a red screen consisting of a 3 mm. thickness of a solution of perchloride of iron, and a green one of a solution of chloride of nickel. He, L. Weber, ‡ V. Della Casa, and M. Böhm § proposed definite methods of dealing with these on a scientific basis, but they are too complicated for ordinary industrial use, and the screens absorb much light. When the colour is the same, an accurate and symmetrical balance may be obtained with any good photometer. The screens appear to be illuminated to exactly the same degree quantitatively and qualitatively; or, if contrast screens are used, the contrasts appear to be identical. But when the colour of the lights is appreciably different, the appearance of the photometer is no longer symmetrical. Differences of quality or hue are so insistent that it is difficult to ignore them and to attend to the

* Trotter, "Notes on the Light of the Electric Arc," *Journ. Inst. Elec. Eng.* xxi. 379.

† *Comptes rendus*, cxvii. 1428.

‡ *Elec. Zeit.* v. 166 (1884); *La Lumière élec.* xii. 468. Palaz, *Photométrie industrielle*, pp. 82-90 (Paterson's translation).

§ Zurich Conference, 1903, *Journal of Gaslighting*, lxxxiii. 959.

quantity of illumination, or luminosity or brightness of the screens.

No assignable quantity of oranges can be said to be equal to or identical with a score of herrings, and a quantity of red light cannot be adjusted to produce on a white screen an illumination identical with that produced by a given green light. In this sense, von Helmholtz was justified in denying the possibility of a physical comparison of differently coloured lights. In photometry, however, it is not the illuminations which we are comparing, but sense-impressions arising from them. When the sense-impressions are simple the comparison is easy, and small quantitative inequalities are recognized and may be reduced to a negligible amount, thus giving a good photometric balance. But if the lights differ in colour, or if, the colours being the same, the texture of the screens differ, there will be an apparent difficulty.

It is of no use to alter the adjustment of the photometer in the search for some position in which the fields appear to be identical. When the best possible balance has been effected the colours will be as apparent as ever. Turning the handle, or moving the working lamp or the photometer head in one direction makes one field clearly brighter, and movement in the other direction manifestly darkens it. But the colours do not change materially if at all. Here we have the means for separating the sense-impression of brightness from the sense-impression of colour. So long as the photometer is standing fixed, distinction between them is difficult, but as soon as it is in motion, one of them, that of brightness, alters, and the other, that of colour, remains unchanged. Rapid alteration accentuates the distinction.

Bouguer met with the difficulty and wrote : *

The comparison of two lights of different colours in the way we have advised is chiefly difficult (*embarrassante*) in the case in which it should be done with more care ; that is when the two forces nearly approach equality. But there is one point at which one of the two lights certainly appears stronger than the other, and another point at

* *Traité d'optique*, p. 50.

which this light certainly appears more feeble, there is therefore nothing to be done but to take the middle between the two extremes.

Ritchie gave very similar directions.* His photometer was of about the size of a match-box, and merely lay on a board. In modern times much of this difficulty has been due to the use of heavy, clumsy, stiff photometers, and with such apparatus the difficulty is a real one. But Abney, using a freely adjustable mechanism, found little difficulty in comparing "soldier" red and "signal" green, to within about 2 per cent. He generally caused two patches of coloured light, each about one inch (25.4 mm.) square, to fall on a white screen. He could dim the brighter patch by means of the rotating sectors until they appeared to him, and to his colleague, to be of equal luminosity. If now, the brightness of one patch was reduced by a definite amount, say by moving one of the lights, he could again bring the luminosity of the patches to an equality by an adjustment of the requisite proportion. When he, and any one who follows his directions, can produce this result with an accuracy, depending of course either on practice or on a nice discrimination of what painters call tone, and can repeat the operation with the same result, it is clear that a physical comparison is possible.†

Abney's Method.—The secret of this operation, which appears so difficult or even impossible to some people, is given by Abney as follows :

On two small screens are a red and a green patch of monochromatic light—a look at the green shows that it is much brighter than the red. Rotating sectors, the apertures of which can be opened or closed at pleasure during rotation, are now placed in the path of the green ray. The apertures are made fairly small, and the green is now evidently dimmer than the red. When they are well open the green is once more brighter. Evidently at some time during the closing of the apertures there is one position in which the red and green must be of the same brightness, since the green passes through the stage of being too light to that of being too dark. By gradually

* See page 89, and *Trans. Roy. Soc. Edin.* x. 443 (1826).

† Abney, *Proc. Roy. Soc.* x. 34 (1889).

diminishing the range of the "too open" to "too close" apertures we arrive at the aperture where the two colours appear equally bright. The two patches will cease to wink at the operator, if we may use such an unscientific expression, when equality in brightness is established. This operation of equalising luminosities must be carried out quickly and without concentrated thought, for if an observer stops to *think*, a fancied equality of brightness may exist, which other properly carried out observations will show to be inexact.*

Most people in their first attempts at the photometry of different coloured lights, when the best possible fixed balance has been obtained, and the field of the photometer exhibits the two colours as plainly as ever, recollect the uniformity of the field of the photometer when the lights are of the same colour, and feel that a good deal more is to be desired.

The next mistake is the common use of stiff or heavy photometer heads or carriages. The "winking" described by Abney cannot be carried out quickly if the movable part of the photometer is heavy. Reduction of friction by wheels or balls may make the motion "perfectly soft and gentle," as Rumford recommended, but that is only half the secret. It is desirable, if this method is to be adopted, that the movable part shall be light. The weight of a Lummer-Brodhun head, as generally mounted, linked to a working lamp, both of these being moved together, makes it impossible to follow Abney's directions, even if every practicable part is made of aluminium, and ball bearings used. S. P. Thompson has suggested that the working lamp should be mounted on a spring support, so that it can nod to the right and left, about a well ascertained mean point. That would help matters in the case of a heavy movable part, but it does not give the quick reduction of amplitude of motion which is needed. With a heavy or stiff photometer the Abney principle must be abandoned, and the movable part, whether head or lamp, must be moved slowly up to the point of balance, beyond it, and back again. After considerable practice, very accurate work can be done in this way, but it is fatiguing and slow.

* *Journ. Inst. Elec. Eng.* xxxii. 179; and *Colour Measurement and Mixture*, p. 79.

Ayrton has enthusiastically described a combination of these methods :*

It is quite possible to compare a red light with a blue light . . . and to get marvellous accuracy. The secret was given by Sir William Abney, but it is so absurdly simple that I want again to impress it upon you, because the result is wonderful. Mr. Medley, in a paper which he read with myself before the Physical Society in 1895,† described how by taking two differently coloured lights, you could get the same measurements over and over again within $\frac{1}{3}$ per cent, without any coloured glass at all. The secret is this. First you oscillate the photometer until you get the best balance you can, then you oscillate one of the standards, one person oscillating it while the second person is getting a final adjustment of the photometer.

The Purkinje Effect.—Before going further into this subject of the photometry of differently-coloured lights, or, as it is rather pedantically called by some writers, heterochromatic photometry, a real difficulty must be noticed. Purkinje ‡ found that when two lights or illuminated surfaces of certain different colours are first adjusted to give equal brightness, and then are reduced or increased together in the same amount, the brightness is no longer equal. The effect is most marked when red and green are used, but it is important to observe that the effect is only important at feeble illuminations. It is not difficult to find a red flower and a green leaf in a garden, of such colours, that an artist painting, drawing, or etching in monochrome would have no reason for representing one darker than the other, whether in sunlight or in shade. But as daylight fades, red and violet begin to lose their vividness, orange becomes yellower, and in the twilight a red geranium may appear black. Green and yellow are the last to disappear into grey.§

The Purkinje effect has been investigated by Abney and Festing || without alluding to this name, and it has been considered from psychological and from physiological points of view by various writers, ¶ and even from a mathematical point

* *Journ. Inst. Elec. Eng.* xxxii. 206.

† *Proc. Phys. Soc.* xiii. 455.

‡ Purkinje, *Physiologie des Sinnes*, ii. 109.

§ Abney, *Colour Vision*, chap. viii.

|| *Phil. Trans. Roy. Soc.* vol. clxxxv. A (1892).

¶ See Liebenthal, *Praktische Photometrie*, p. 61; and Helmholtz, *Physiolog. Optik*, p. 317.

of view without alluding to red and green. A practical discussion of the subject will be found in J. S. Dow's paper on Colour Phenomena in Photometry.* Dow used ruby red and signal green glasses in some of his experiments. These bring out the effect in a striking manner; but it must be remembered that while these are of great scientific interest, they are outside the range of ordinary photometry. As a matter of scientific investigation it may be better to use lights widely differing in colour; the effects observed are comparatively small, but for practical photometry the object is to reduce the effect to a negligible quantity. Dow used several ordinary lights without coloured glasses, such as a glow-lamp at 3.7 watts per candle-power, Nernst lamp, Methven gas standard incandescent gas mantle, Harcourt 10-candle Pentane, and a Fleming standard glow-lamp. He employed Lummer-Brodhun, Bunsen, Joly, and Flicker photometers. The general result of his investigations was that the effect is serious only when very feeble illuminations are used, illuminations which are unnecessary and unlikely in ordinary photometry; and that photometers without telescopes and eye-pieces are better than those with such accessories.

The Purkinje effect need give no trouble in ordinary candle-power photometry. Abney takes this view, and Ayrton emphatically supported it.† In ordinary photometry, that is, the comparison of the brightness of two adjacent screens, the Purkinje effect does not begin seriously to alter the relative brightness of red and green lights until the illumination is reduced to about 0.025 foot-candle (0.25 metre-candle). Dow ‡ finds that visual acuity for red light begins to fall off rapidly with illumination less than about 0.1 foot-candle, and is followed by the green; but that is another matter.

In illumination photometry, on the other hand, low illuminations often have to be measured, and here the Purkinje effect would have full play and would render accurate work impossible, were it not for the fact that in practice these red and green

* Dow, *Proc. Phys. Soc. Lond.* xx. 245 (May 1906).

† *Journ. Inst. Elec. Eng.* xxxii. 180 and 206.

‡ *Illuminating Engineer*, London, ii. 238.

illuminations are never met with. So long as the difference between the colour of the lamp in the photometer and that of the lamp which produces the illumination to be measured do not greatly differ, the Purkinje effect may be disregarded.

Colour Vision.—A further difficulty arises in consequence of differences of colour perception in different parts of the field of vision. At the centre of the retina of the eye there is a yellow spot called the *macula lutea* having an angular magnitude of some 6 or 8 degrees, and at the middle of this there is a very thin part of the retina called the *fovea*. Its angular magnitude is about $2\frac{1}{4}$ degrees, that is to say, the image of a disc 0.4 inch diameter at 10 inches from the eye (or 20 mm. at half a metre) corresponds with the foveal area of the retina. It is commonly stated that it is here that vision is most acute, but it is indeed only here that vision is acute.* The yellow spot is not so sensitive to green as the surrounding parts of the retina. The outermost parts of the retina are almost incapable of judging colours at all unless very brilliant. Owing to the facility with which we move our eyes we are hardly conscious of the limited area of acute vision, nor of our deficiency in colour perception, especially of red, in the outer parts of the field of vision. Nevertheless we are influenced by the indistinctly seen parts, and this causes a difficulty in the photometry of coloured lights.

If an attempt be made to balance a reddish light against a greenish light with any kind of photometer in which two adjacent fields of these colours are seen, the balance will be affected by the angle which they subtend. Let them first be included well within the yellow spot by standing at some distance from the photometer while making the adjustment. Then approach the photometer, or use a lens to amplify the image. The greenish light will appear to be brighter, for some of the outer parts of the retina more sensitive to green affects the judgment. The question arises, which is the true balance?

* Cut a circle half an inch in diameter from a sheet of paper. Make a dot at the centre of the piece cut out, and lay it on a page of closely printed figures such as a table of logarithms. Fix the eye on the dot and it is very difficult to read any of the surrounding figures. Then place the sheet of paper on the page and fix the eye on the central figure in the hole. It will be found possible to read nearly all the figures.

The experiment itself seems to afford the answer. Though we apparently derive most of our visual impressions from the fovea, we are largely influenced by the peripheral parts of the field, and as in daily life we do not restrict that field to a few degrees, practical photometry should not be based upon small fields when colour differences are concerned.

It is well known that the outer parts of the field of vision are peculiarly sensitive for very faintly illuminated objects. Sailors pick up distant lights, and astronomers "glimpse" stars* by the peripheral retina, when these objects are invisible on the fovea. The outer parts of the retina while useless for ordinary acuity tests, such as reading print or making out a fine pattern, seem to be peculiarly capable of estimating small differences of illumination. A small want of balance in a photometer may be detected by averted vision, fixating the eye on some point near the photometric field. A slight shift of the point of fixation is liable to enhance the greener of two lights, but if the eye is turned still further the image falls on parts of the retina which are almost incapable of perceiving colour, though some practice is required to pay attention to an object at which vision is not directed.

Abney and Festing † in one of their papers on colour photometry describe an investigation on the sensitiveness of the peripheral region of the retina.

A white spot very feebly illuminated was placed 6 inches from the patch on which the beams to be compared were thrown. One eye was closed and the other directed centrally to the white spot, the observer being at a distance of 4 feet from it. The image of the patch was thus received on a part of the retina beyond the boundary of the yellow spot. It may appear strange to others, as it did to ourselves at first, that the luminosities of the shadows could be compared with almost greater facility than they could be when looked at centrally. When a comparison was to be made, the presence of the colour often appeared not exactly to vanish, but to offer no difficulty to the reading.

* W. McDougall, "Intensity of Sensation and Duration of Stimulus," *The Journal of Psychology*, i. 183.

† *Phil. Trans. Roy. Soc.*, 1892, vol. clxxxiii. A, sec. xlv. p. 533.

In dealing with coloured lights I prefer to use a photometer having a field divided into two equal parts such as a Ritchie, Harcourt, or Conroy (and of these I prefer the Conroy), although with lights of the same colour, I can obtain better precision with a well cut perforated screen.

Crova's Method.—In 1881, Crova* briefly proposed a method of comparing lights of different tints. This was the outcome of a spectro-photometric investigation,† that is to say, a photometric examination of the whole range of a spectrum, comparing the luminosity of the different parts. This comparison seems to have been made on the basis of acuity of vision, and not on that of simple luminosity as in the work of Abney and Festing. A more complete account was published in 1885.‡ The word *teint* instead of *couleur* is used advisedly, for the method is not adapted to the comparison of lights of strongly different colours, but to the various tints § of incandescence.

The comparison of two lights by a spectro-photometer, step by step throughout the range is necessarily tedious, but Crova found that a comparison at one point only, viz. wave-length (λ), 5820 ten-millionths of a millimetre is a measure of the whole luminous radiation. He made a large number of experiments, and gives as an example a comparison of the light of the sun with that of a Carcel lamp. He plotted a curve from the spectrum of each, the ordinates being luminous intensity or candle-power, and the abscissae being wave-lengths. The curves were cut out from paper and weighed, and the weights were assumed to be proportional to the total luminous intensity. The ratio was found, and the curves were re-plotted with equal areas. Fig. 121 represents these.¶ The intersection is at wave-length 5820, or the pure yellow part of the spectrum.

* *Comptes rendus*, xciii. 512 (1881).

† "Note sur les spectrophotomètres," *Journal de physique*, viii. 85.

‡ "Comparaison photométrique des lumières de teint différentes," *Ann. de chim. et de phys.* 6th series, vi. 528; and *La Lumière élec.* xviii. 549.

§ "Tint may be defined as the degree of purity of a colour. Thus, bright yellow, buff, and cream colour form a series of colours of nearly the same hue, but varying in tint." Clerk Maxwell, *Colour Vision, Scientific Papers*, ii. 271; and *Proc. Roy. Inst.* vi.

¶ In the original paper in *Ann. de chim. et de phys.*, and in the reprint in *La Lumière élec.*, the figure 582 appears to have been substituted for 564 by mistake. I have ventured to correct this.

Crova goes on to describe the preparation of screens to cut off all light except in the neighbourhood of λ 5820. Solutions of perchloride of iron and chloride of nickel in a glass receptacle containing 7 mm. thickness of solution are recommended.

So far as Crova's account of his method goes, it seems to be empirical, and notwithstanding his full details, it is not very convincing, for no reason is given to show that there is any objective connection between the total candle-power and the candle-power of yellow light. But independent support can be found for it, which places it on a sound scientific basis of a subjective nature, depending on a peculiarity of the eye.

In a paper "On the Transmission of Sunlight through the Earth's Atmosphere," by Abney,* a section on "Measurement of Photographic and Optical Values of Total Intensity equivalent to the Measurement of a Single Ray," begins as follows:

A remarkable deduction now presents itself, from the fact that if we divide μ and μ_1 (coefficients of absorption) by K (a constant) in the results given by plotting the areas, we find that the results are numbers which . . . represent wave-lengths 5570 and 4540 respectively; so that if we observe the total value of the light optically, it is equivalent to observing monochromatic light of λ 5570, and if we use bromiodide of silver for registering the intensity it is equivalent to measuring a ray of λ 4540.

The colour at 5570 is greenish-yellow, and at 4540, blue inclined to violet-blue.

Five years later in one of the papers by Abney and Festing on Colour Photometry,† the luminosities of two spectra were

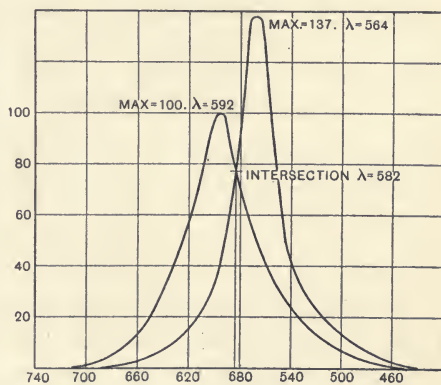

FIG. 121.

* *Roy. Soc. Phil. Trans.* vol. clxxviii. A (1887), sec. xviii. p. 271.

† *Roy. Soc. Phil. Trans.* vol. clxxxv. A (1892), sec. I. p. 557; and Abney, *Colour Vision*, p. 103.

compared, one 132.5 times stronger than the other, but plotted with the same maximum. Fig. 122 represents the curves, and it will be seen that they intersect at the arbitrary scale number 44.3 which corresponds with wave-length 5498. The more

feeble spectrum has become shifted, and the maximum luminosity is in the green almost at the line E in the solar spectrum. This is in accordance with, and indeed demonstrates, Purkinje's effect.

A third investigation of Abney and Festing* supports Crova's method in a striking manner.

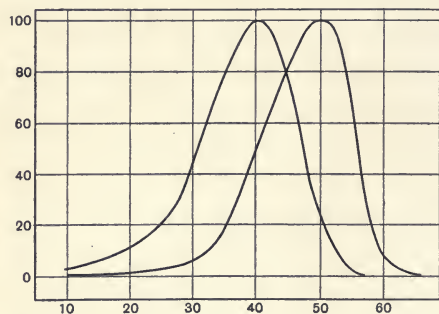

FIG. 122.

Having found that the curves of luminosity of a spectrum when feeble and when bright differed; it became a matter of some importance to ascertain in what manner the relative luminosity of the rays varied when the intensity of the light which formed the spectrum was

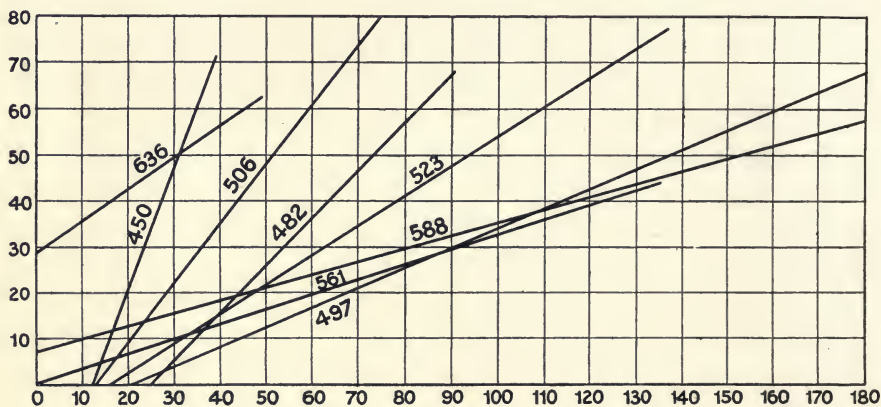

FIG. 123.—WAVE LENGTHS IN HUNDRED MILLIONTHS.

altered in a definite ratio. . . . The results thus obtained were plotted, and some typical ones are shown in Fig. 123. The ordinates are the apertures of the sectors in the monochromatic rays, and the abscissae, the apertures in the white beam. The tangent of the

* *Phil. Trans. Roy. Soc.*, 1892, vol. clxxxv. sec. li. p. 559.

inclination to the vertical of the curve at any point, therefore, represents the ratio of the luminosity of the coloured to that of the white beam for a certain intensity of light. If this ratio were the same for all intensities the curve would become a straight line starting from the origin. This is the case, it will be seen, with one ray only, that at . . . about λ 5618. This ray and white light would therefore be extinguished together. It may be more than a coincidence that this ray does not differ much in wave-length from that ray which, as stated by one of us in a paper on the Transmission of Sunlight through the Earth's Atmosphere, was found to be affected to the same degree as the integrated light of the whole spectrum, no matter what was the thickness of the atmosphere through which it had passed.

Koenig* found that the eye is most sensitive to wave-lengths in the neighbourhood of 5100 for moderate intensity of illumination, and shifts to about 5600 for high intensity. E. L. Nichols † states that the maximum luminosity of daylight is wave-length 5800, and this, he adds, suggests that the eye has developed itself so as to be most sensitive to yellow light simply because the energy happens to be concentrated in this particular region of the solar spectrum.

The discrepancy between Crova's wave-length 5820, Abney and Festing's 5570 in 1887, 5498 (see Fig. 122) 1892, and 5618 (see Fig. 123) also in 1892, may be accounted for partly by the fact that Crova measured the light by the acuity of vision, while Abney and Festing compared luminosities in the ordinary photometric manner. Crova's two curves in Fig. 121 are of equal area. Abney and Festing's curves in Fig. 122 are of equal height. The selection of 5618 in Fig. 123 is perhaps the best, so long as the lines are straight. The paper explains the conditions under which they cease to be straight.

Crova's method is important on account of its simplicity and because it altogether evades the Purkinje effect. But his mode of carrying it out is not practicable for ordinary photometry because so much light is cut off.

* *Physiolog. Optik*, 1903, p. 144.

† "Daylight and Artificial Light." *Illuminating Soc.*, New York, May 1908; and *Illuminating Engineer*, London, i. 686.

In ordinary practical photometry there is no necessity for pushing the method so far as Crova suggested. The difficulty with ordinary illuminants is not so very great, and a pale tint will suffice. I have tried various pigments and stains for colouring the screens of a Conroy photometer, but have found it impossible to get rid of the colour difference unless that difference was so slight as to be not worth troubling about. The reason is that all such pigments reflect a good deal of white light. The best way seems to be to use a pair of white screens, and to place in the opening of the photometer head a transparent screen stained to the right colour.

So far, the action of the Crova screen has been considered from a theoretical point of view, but it has a very simple practical aspect. If, when a reddish light has been balanced as well as possible against a whiter light, the photometer is viewed through a red glass, the redder field will appear brighter, and the white one less bright. If a blue glass is used the reverse will happen. It is clear that between the two there should be a colour which will not disturb the balance, but will remove or largely reduce the colour difference. This is the way in practice to choose the screen.

Ordinary photographic plates cleared with hyposulphite of soda make useful screens. A plate stained with naphthol green of such a depth that it will remove the colour difference between a Hefner lamp and a metal filament lamp run at about one watt per candle, is rather too blue. The whiter lamp appears to be about 10 or 12 per cent too bright. With a paler stain the colour is less blue, and does not remove the colour difference, but the white light is favoured only about 2 or 3 per cent. Another screen stained yellow with tartrazine used with a pale naphthol green screen practically eliminates the colour difference without disturbing the balance. The loss of light is not enough to be serious, and in dealing with powerful lights, it is rather an advantage.

The Flicker Photometer.—In 1896, F. P. Whitman described* an investigation into the luminosity of papers coloured

* *Physical Review*, iii. 241.

with various pigments. A piece of coloured cardboard was cut in the shape A, Fig. 124, and a piece B of another colour was fastened to the side of a Ritchie wedge. The piece A was spun round, and was observed through a diaphragm C. The illumination was adjusted until flicker disappeared, and thus the luminosities of the different colours were compared. Two years later* he described the application of this principle to photometry. In his former experiments the lights on each side were similar, and the screens were the object of examination; in the latter the screens were identical, preferably but not necessarily white, and the relative candle-power of the lights was the quantity to be measured. For this he made a wooden frustum of a cone, the lower base being 20 cm. ($7\frac{7}{8}$ in.), the upper base 15 cm. ($5\frac{7}{8}$ in.), and the height 3.7 cm. (nearly $1\frac{1}{2}$ in.). This was cut along the axis, one half was reversed in direction and the halves were fastened together in this new position. The whole was then mounted so as to rotate about the axis of the cone which was placed parallel to the axis of the photometer bar. Fig. 125 is Whitman's singularly uninteresting illustration, and Fig. 126 is drawn from a disc made in accordance with his instructions, but with the edges of the cut "backed off" to give a sharp junction. The effect is to present to the eye first one side and then the other of a Ritchie wedge.

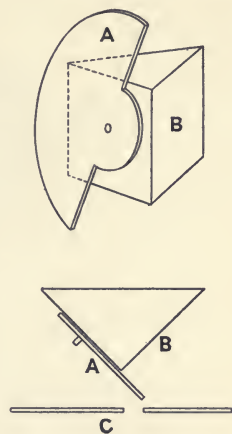

FIG. 124.—WHITMAN'S FIRST FLICKER APPARATUS.

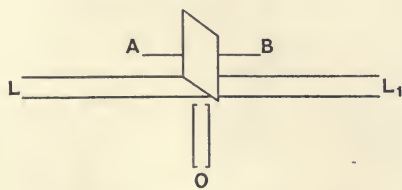

FIG. 125.—WHITMAN'S DIAGRAM.

two faces by a reciprocating lens. The Simmance and Abady flicker photometer ‡ combines these two methods. The rotating

* *Science*, viii. 11 (1898).

† *Science*, vii. 757, and viii. 11 (1898).

‡ *Proc. Phys. Soc.* xix. 39.

cone is used, but instead of suddenly presenting first one face and then the other, the edge swings backwards and forwards across the field of view. For this purpose a peculiarly shaped

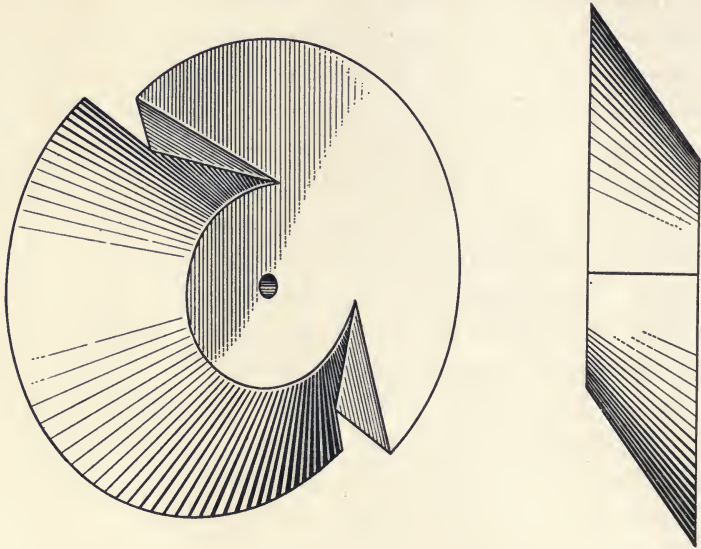

FIG. 126.—WHITMAN'S DISC FOR FLICKER PHOTOMETER.

disc of plaster of Paris is used. Fig. 127 shows four different views of the disc in positions 90 degrees apart. Various similar discs have been made by Kruss,* who has also used sector

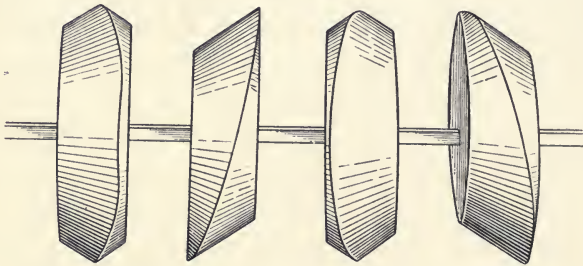

FIG. 127.

discs on either side of a Ritchie wedge or Lummer-Brodhun photometer.

A defect in most kinds of flicker photometers is that the

* *Phys. Zeit.*, Jahrgang No. iii. p. 65; and *Journ. für Gas und Wass.* xlvii. 129 (1904).

appearance of the field does not indicate in which direction the adjustment should be made. The only resource is to adjust beyond the balance and to come back again, unless after considerable experience the adjustment can be swiftly made up to the point. The Wild flicker photometer* is free from this drawback. A Bunsen disc is used, a semicircle or two quadrants being waxed, and a semicircle or the opposite quadrants being plain. It is rotated in the usual position in the photometer head, and is mounted on an axis driven by clockwork or a small motor. Both sides are viewed simultaneously by mirrors or prisms.

If a disc of cardboard half white and half black, or with white and black sectors, moderately illuminated is spun round at a moderate speed, a flicker may be seen. If the speed is increased the flicker disappears, and the disc appears a uniform grey. If now the illumination be increased the flicker will reappear.

An elaborate investigation has been made into this by Kennelly and Whiting,† but mainly in connection with the intermittent illumination of white or strongly coloured screens by a single lamp, and with the view of considering the photometry of alternating current arc-lamps and rotating glow-lamps. Their results are of great scientific interest, but they are not directly applicable to flicker photometry. With an illumination of 18.6 foot-candles (200 metre-candles), alternate full illumination of the screen, and extinction of the light by revolving sectors, the frequency at which the illumination appeared steady was 53 alternations (complete cycles) of black and white per second. With less illumination the frequency at which flicker disappeared fell gradually, and at 2 foot-candles was 42 per second. Beyond that it fell rapidly, and at 0.5 foot-candle was 38 per second, and at this point the frequency was proportional to the illumination. After that the frequency fell rapidly, as shown in curve A in Fig. 128.

* *The Illuminating Engineer*, London, i. 825.

† "The Frequencies of Flicker at which Variations in Illumination vanish," *Nat. Elec. Light Assoc.*, New York. Reprinted in *The Illuminating Engineer*, New York, ii. 347 (1907).

A further set of experiments (B) were made with partial extinction of the light. Observations were difficult to make in the case of a 3.3 per cent difference in the successive illuminations, and the lowest range of flicker which could be recognised with certainty was with a 1.4 per cent variation. Among fifteen deductions made from these experiments, the authors find that the vanishing-flicker frequency does not depend upon the mean

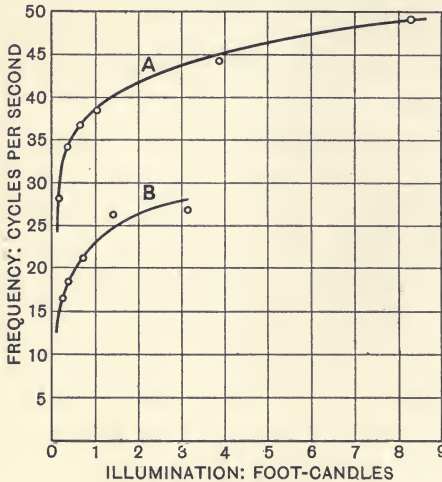

FIG. 128.

illumination on the screen, or only to a small degree, but it depends upon the maximum and minimum cyclic illuminations. By altering the size of the screen, or the distance of the eye from a screen, it was found that the larger the area of the retina stimulated, the higher is the vanishing-flicker frequency; but not in the same proportion.

T. C. Porter has carried out quantitative work* on this subject, but in a form which does not bear directly on practical flicker photometers. J. S. Dow has written on the physiological principles underlying the flicker photometer,† and on the theory of the instrument.‡ Much of his work has been done with coloured lights. H. Morris-Airey§ has also written on the subject, and throws considerable doubt on the use of the flicker photometer as a measuring instrument, unless the colour difference is very slight. None of these writers seem to have discovered what it is that the flicker photometer really measures.

Polimanti|| found that the results of the flicker photometer

* *Proc. Roy. Soc.* lxi. 347 (1898), and lxx. 313 (1902).

† *Proc. Phys. Soc.* xxii. 80.

‡ *The Electrician*, lviii. 607.

§ *Journ. Inst. Elec. Eng.* xlv. 177.

|| "Über die sogenannte Flimmerphotometrie," J. v. Kries, *Abh. z. Physiol. der Gesichtsempfindungen*, 1902, ii. Heft lxxxiii.; *Journ. für Gas und Wass.* xlvii. 129 (1904); and Liebenthal, *Prakt. Phot.* 244.

agree with those of ordinary photometry when the central part of the retina is blocked out, and the light is allowed to fall on the outer or peripheral parts only. H. Kruss* criticises this, but without re-establishing the flicker photometer as a trustworthy instrument. Blondel is somewhat sceptical about the flicker method.

The Speed of Flicker Photometers.—Very little has been published on the relation between speed and illumination. Rood recommends 16 per second. The relation between flicker, speed, and illumination is a complex one, and this is not surprising when the results of a sudden flash of light on the eye † are investigated. Shelford Bidwell, McDougall, and others have found that a series of pulses of sensation are set up and are followed by the well-known after-image. The first few pulses follow each other at intervals of 0.025 to 0.03 second and are concerned with the central part of the retina; the succeeding ones follow more slowly and act on the outer parts. This necessarily affects the perception of colour.

If a flicker photometer is held at rest between two lamps of the same colour, and is so set that the field is evenly divided into two halves, it is practically equivalent to a Ritchie or Conroy photometer, and if the workmanship of the junction is good, an alteration of about one per cent on either side will throw it out of balance. When it is set slowly in motion the junction will be detected every time it passes across the field, and this will give a slight flicker, which vanishes when a speed of about 5 or 6 cycles (10 or 12 changes) per second is reached. When this steady condition exists, a slight disturbance produces a flicker.

For experiments with coloured lights I used a carbon glow-lamp run at a colour corresponding with a Hefner lamp; and a tungsten lamp run at about one watt per candle. With such lights the flicker is of two kinds. One is due, as with lights of the same colour, to difference of illumination, the other to difference of colour. When the instrument is held at rest so

* *Phys. Zeit.* v. Jahrgang, No. iii. 65-67, Dec. 1903.

† W. McDougall, "The Sensations excited by a Single Momentary Stimulation of the Eye," *Journal of Psychology*, i. 78-113 (1904).

that the field is divided into two halves, the colours will be plainly seen. They are really two tints of yellow, but one of them appears pale yellow or pale orange, and the other by contrast, pale blue or green. A balance may be made with more or less difficulty according to the difference of colour and the skill of the observer. Different observers will make slightly different balances depending on their individual opinions and perhaps on differences in their vision. If the instrument is set in motion at a slow speed, pale orange and pale greenish fields will follow each other smoothly. If the balance is disturbed there will be, in addition, a different sensation of a jarring flicker. When the alternations follow each other faster than about 10 or 12 per second, the colours disappear if a good balance is effected, and the flicker is perceived if the balance is disturbed.

With some kinds of flicker photometer the speed must be varied to suit the illumination, but with the Whitman disc

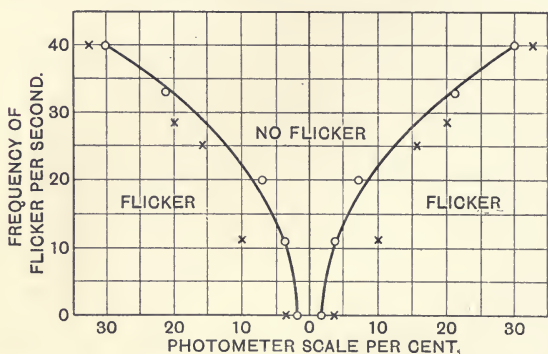

FIG. 129.

illustrated in Fig. 126, I could not discover any such relation. The best results were obtained at about 7 or 8 cycles (14 or 16 changes) per second, the wheel running at about 450 revolutions per minute. A disturbance of about 4 per cent on either side of the middle position causes flicker. At 10 cycles per second the region of no flicker increases to about 7 per-cent, and at 20 per second to 30 per cent. These results are shown graphically by the small circles in Fig. 129. The curves are a pair of such curves as those of Kennelly and Whiting (Fig. 128) placed back to back. The crosses in the same diagram are the means of measurements made with a Wild flicker photometer at East London College under the direction of Prof. J. T. Morris.

Fig. 130 gives the results of Dow's experiments with a Wild flicker photometer.* The scales have been rearranged to correspond with those of Figs. 128 and 129. He used green and white light, and found a marked difference between an illumination of 20 candle metres (nearly 2 foot-candles) and 2 candle metres (nearly one-fifth of a foot-candle). The dotted lines show the approximate limits below which the colours began to appear, and the opening of the curves at low speeds indicates the insensitiveness or the difficulty in estimating the effect, rather than an increase of the region of no flicker. Several writers have stated that the flicker photometer cannot be used for feeble illumination. I found no appreciable difference, using the Whitman pattern, between 0.04 foot-candle (or a candle at 5 feet) and 12 foot-candles. At the low illumination the field alternated between a dusky brown and an olive green.

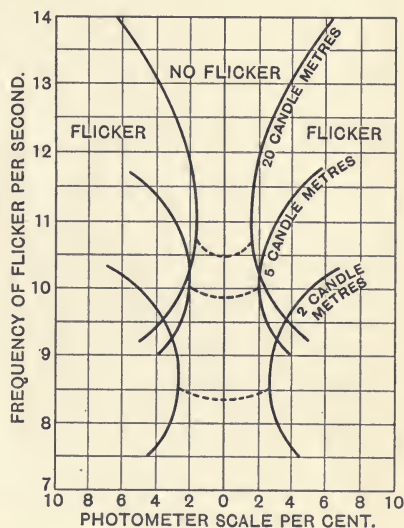

FIG. 130.

The curves given in Fig. 129 and 130 must not be taken to indicate errors, but limits of flicker and no flicker. When the range is 5 per cent on each side, it is possible to bisect this with an error of not more than $1\frac{1}{2}$ or 2 per cent. I understand that some of those who have worked with a Simmance-Abady flicker photometer can get good results with it. My own experience has been chiefly with the Whitman, and has not been sufficient to give me a good opinion of its value as an instrument of precision.

Selective Emissivity.—The physics of the production of light is beyond the scope of this work, but reference may be made to lights which differ intentionally or otherwise in colour from that of ordinary incandescence. The greenish hue of

* *The Electrician*, lix. 257.

certain incandescent gas mantles is accidental and serves no useful purpose. The yellow colour of certain flame arc-lamps is also probably accidental, but though occasionally unpleasant, has some merits. Mr. R. E. S. Cooper, District Engineer of the London, Brighton, and South Coast Railway, has investigated the absorption by the atmosphere and of mists and fogs, and is seeking for a type of incandescent gas mantle which will give the most penetrating light. For its candle-power, the light of a bonfire probably penetrates mist and fog better than any other kind of light, but it is not an economical source of light. An ordinary electric arc is particularly ill-suited for piercing mist, since its light is rich in the more refrangible rays, and these are the first to be absorbed. Similarly, the green light of a gas mantle is to be avoided for extensive lighting. Examination of the lamps by a spectrophotometer would be too elaborate, and Mr. Cooper has used instead, a set of coloured gelatine light filters supplied by Messrs. Wratten and Wainwright. These allow light of the following wave-lengths to pass—red end to 6100, 6000 to 5500, 5400 to 5100, and 5100 to 4600. Photometric tests with these four screens are sufficient to discriminate between different gas mantles, and the operation is carried out much more easily than the comparison of two spectra. An acetylene standard is used.

Coloured screens have been used by H. E. Ives* for examining the colours of different sources of light. He employs three screens, blue, green, and red, having maxima at wave-lengths 4550, 5350, and 6350. A tungsten lamp is used as a standard, and the result, which is qualitative and not photometrical, is expressed as three numbers. It is obvious that these numbers depend on the depth of tint of the glasses, but it is only stated that the range of spectrum is "fairly narrow."

* *Second Annual Convention of the Illuminating Society of New York*, abstracted in *The Illuminating Engineer* (London), ii. 1019.

CHAPTER IX

ERRORS

Accuracies, Errors, and Mistakes.—The science of photometry consists of intelligent apprehension of the principles of the subject; the art of photometry lies in skilful avoidance of errors. One man may have a thorough knowledge of the theory, may be able to treat it mathematically, may be familiar with apparatus ancient and modern, and yet may be unable to measure the candle-power of a lamp without making errors or mistakes amounting to 8 or 10 per cent. Another, practising photometry as a trade, totally ignorant of the law of inverse squares, or any other theory, may be able to make his own sensitive Bunsen screens and test several thousand lamps a day without exceeding the limit of error, say $2\frac{1}{2}$ per cent.

By a peculiar ambiguity in our language an “accuracy of one per cent” is often used to express the degree of correctness of a measurement, when an error of one per cent is implied. The word “precision” is perhaps better than “accuracy,” because it allows of degrees of comparison. An expression is either accurate or inaccurate; it cannot be said to be rather accurate, it may be said to be almost accurate.* But common usage sanctions “highly accurate” and various degrees of truth and honesty. Errors with which we are here concerned are the results of attempts to make a measurement under difficult circumstances. It is possible, but very improbable, that the true value may be obtained by any one measurement. There are several different kinds of errors: they

* For a fuller discussion of accuracies and errors, see an article by the author, *Electrical Engineering*, vol. i. No. i. p. 21, from which parts of this section are extracted.

may be divided into two classes, variable errors, and constant errors. Variable or personal errors depend on the individual. Constant errors relate chiefly to the instrument or mode of measurement.

Some writers speak of known and unknown errors. If an error is known, it can be allowed for, and should be called a correction, not an error. It is not easy to make a clear distinction between errors and mistakes. Errors are inversely proportional to skill; mistakes, to carefulness. If the scale is read through an opening in the movable carriage of a bar photometer, the opening should be wide enough, or the numbering of the scale should be full enough, to allow at least two fully numbered divisions to appear in an opening.



FIG. 131.

In Fig. 131 it is easy to make the mistake of reading the indication as 921 instead of 879. That would be a sheer mistake or blunder.

In using a Hefner or Harcourt lamp as a standard of light, inaccuracies will be introduced if corrections for atmospheric pressure, moisture, and CO_2 are neglected. It may be said that to neglect such corrections is a mistake, but their importance depends entirely on the precision aimed at, and if it is decided to neglect them, the inaccuracies become errors of the mode of measurement chosen. In investigating the ageing of an electric glow-lamp or of an incandescent gas mantle, by taking measurements from time to time against a flame standard, the corrections should be made, but it would be better to avoid them by using a sub-standard electric lamp which is used only when measurements are in progress. For checking a portable photometer before starting for an evening's work out of doors in measuring candle-power, a single test against an uncorrected flame standard is sufficient, for uncontrollable errors due to light reflected from buildings, and to uneven glass of globes or lanterns, will mask the small errors due to neglect of the corrections.

Personal errors differ very considerably from instrumental.

Personal errors in photometry depend upon such matters as the following :—1. Familiarity of the worker with the particular form of photometer used. 2. General experience with photometric work. 3. Physical condition of the worker. 4. The speed of working, or in other words, the time allowed for each measurement. 5. The colour difference. 6. The steadiness of the light. 7. The illumination on the photometer.

The Calculation of Errors.—The quantity which measures the degree of precision or accuracy is the error. The application of the artificial mathematical theory of errors is of little use in ordinary scientific work, and is futile in industrial measurements where the object is to obtain a numerical result and an idea of its accuracy or trustworthiness.

If on the one hand, the object is to compare the combined accuracy of an instrument, of a method, and of an observer, with some other such combination, the “mean error of a single observation” may be calculated. If on the other hand, it is desired to know the accuracy of the mean of a number of observations made under the same conditions, the “mean error of the result” should be found. The errors of the observations are found by comparing the differences between each of a number of observations, and the mean of those observations. The differences are then the object of the investigation, and the mean is the standard to which they are referred. In calculating the mean error of the result, the result is the object of the investigation.

For the former of these two objects, namely, to ascertain the accuracy of a method, the tedious rules for finding the so-called probable error must be employed. The investigation of Kennelly and Whiting, to be referred to later, was of this kind. Twenty-five repeated observations of the same quantity is about the smallest number from which a probable error can be reasonably computed.

For all ordinary purposes the mean difference from the mean of a set of observations suffices to measure the precision. To find this, take a number of successive measurements made under precisely similar conditions, and take the average. This

gives the most probable result.* No amount of mathematical theory of errors can produce a more plausible result from this material. The only way to improve it is to take more measurements.

The first column of the following tables gives a set of ten observations which I made with a perforated screen photometer. I consider them good, but I have made better.

	δ	δ^2
1.089	-.0004	.00000016
1.086	-.0034	1156
1.087	-.0024	0576
1.095	+.0056	3136
1.090	+.0006	0036
1.093	+.0036	1296
1.095	+.0056	3116
1.082	-.0074	5476
1.089	-.0004	0016
1.088	-.0014	0196
<hr/> 1.0894	<hr/> .00308	<hr/> .00001504

The mean is 1.0894. The last figure, 4, is beyond the possible range of observation, and should not be recorded as a significant figure. The second column gives the difference between each observation and the mean. The eighth difference is large, but not large enough to warrant discarding the observation as a mistake. The mean of these differences, or residuals as they are sometimes called, is 0.00308. The mean difference from the mean is therefore about 0.3 of one per cent. That is sufficient for all ordinary purposes as a measure of the accuracy of the observations.

The calculation of the mean error of a single observation, of the mean error of the result, and of the so-called probable values of these quantities is rarely worth the trouble, for two reasons at least. In the first place such values deduced from so few observations as 10, are only approximations, and in the second place, few people can spare time to make more

* If all the results are ranged in order of magnitude, the middle one, if there is an odd number, or the mean of the two middle ones if there is an even number, has some claim to be the most probable result, but to place them in order is more troublesome than to add them and divide by the number of results.

than 10 observations of a single quantity, unless for very special purposes. The "probable error of a single observation" is smaller than the simple mean difference from the mean, and may be used for purposes of argument to show that your work is better than somebody else's.

The following working out of these values is intended rather to show that little, if anything, is to be gained by the trouble, for ordinary industrial work. There are two recognised rules for the computation.*

According to the well-known and more rigorous rule,

$$e = \sqrt{\frac{\Sigma d^2}{(n-1)}} \quad E = \sqrt{\frac{\Sigma d^2}{n(n-1)}} \quad (1)$$

where e is the mean error of a single observation, E the mean error of the result, Σd^2 the sum of the squares of the differences paying no regard to sign, and n is the number of observations. The probable errors are $\frac{2}{3}$ of these. A probable error does not mean one that is probable. It is an unfortunate expression. It means that the chances are even for and against any given error being greater or less than the corresponding probable error.

The other rule † is an approximation, and dispenses with the squaring of the differences.

$$pe = 0.8453 \frac{\Sigma d}{\sqrt{n(n-1)}} \quad pE = \frac{pe}{\sqrt{n}} \quad (2)$$

where pe is the probable error of a single observation, Σd is the sum of the differences, and pE is the probable error of the result.

A third, and an extremely simple rule, may be derived from this, when $n = 10$,

$$pe = \Sigma d \times 0.089. \quad pE = \Sigma d \times 0.028. \quad (3)$$

The errors of the set of ten measurements already given, work out as follows:—

* *The Principles of Science*, Jevons, i. 452. *Physical Measurements*, Kohlrausch. *Adjustment of Observations*, Wright and Hayford. *The Theory of Least Squares*, Mansfield Merriman.

† Peters's formula, *Astronomische Nachrichten*, xlv. 32 (used by Kennelly and Whiting).

- (1) The mean difference from the mean 0.00308
 Mean error of a single observation = $\sqrt{\frac{0.00015}{9}}$ = 0.0041
 Mean error of the result = $\sqrt{\frac{0.00015}{90}}$ = 0.0013
 Probable error of a single observation = $\frac{2}{3}$ of 0.0041 = 0.00272
 Probable error of the result = $\frac{2}{3}$ of 0.0013 = 0.00086
- (2) Probable error of a single observation = 0.8453 $\frac{0.00308}{\sqrt{90}}$ 0.00274
 Probable error of the result = $\frac{0.00274}{\sqrt{10}}$ = 0.000866
- (3) Probable error of a single observation = 0.0308 \times 0.089 = 0.00274
 Probable error of the result = 0.0308 \times 0.028 = 0.00086

In the ordinary work of testing lamps in a factory, measurements are not repeated unless it is suspected that a mistake has been made. In some work such as the plotting of a rather irregular polar curve of candle-power in different directions, it may be better to make a single measurement at each of a large number of angles, than to repeat observations at a few angles for the purpose of taking the mean, and securing greater accuracy at those angles.

The foregoing numerical expression of errors is tedious and not very informative. The precision of a set of observations may be clearly indicated when the result is plotted as a curve by recording each observation good or bad as a dot or a little circle, and drawing a curve evenly among them. When a curve is drawn from calculation it is not necessary to record the calculated points; the reader must assume that the author has calculated a sufficient number of points to warrant the drawing of the curve. But when a curve is drawn from experiment it is the duty of the author to place the observations before the reader. The author draws the curve which appears to him to show the result, but the reader should have an opportunity of satisfying himself that the curve is a good fit for the observations, and is enabled to judge of the precision of the work by the distribution of the observed points. Where several observations are made under the same conditions, the mean of these may be taken and indicated by a single point, for in

general they lie so close together that they could not easily be distinguished. Fig. 69 is drawn in this way; each point represents the mean of ten observations. Fig. 96 shows the separate observations of one of these sets. Fig. 147 shows a curve drawn through thirty-one single unrepeatable observations.

For ordinary scientific work, not less than three observations should be made for any given condition. Theory shows that the accuracy increases only as the square root of the number of observations; it is therefore not worth while to make more than ten. This number is convenient for averaging.

Having discussed, perhaps at too great length, what is meant by error, we may go on to consider some of the sources of personal error.

Familiarity with the Particular Form of Photometer.—One who has considerable experience with one or more kinds of photometers may have great difficulty in obtaining good results with an instrument of an unfamiliar type. Long experience with a Bunsen photometer in which similarity of contrast of two neighbouring patterns is looked for, does not fit a worker for securing good results from an instrument of the equality type, where two contiguous screens may be made to appear identical in tone. Arising from such experience, or perhaps depending upon some psychological principle, the perfect match of the halves of the "equality" Lummer-Brodhun photometer, or of the concentric pattern, does not give such good results, with some workers, as a pattern depending upon slight contrast. The Metropolitan Gas Referees' photometer, with its screen of slightly-grained paper, is preferred by those who are accustomed to it, and in their hands yields excellent results, while those who can do equally accurate work with the apparently structureless material of a Conroy, perforated screen, or Lummer-Brodhun, find the former instrument insensitive. Some workers prefer a flicker photometer even for comparing lights of the same colour, while others can do nothing approaching to accurate work with it. There is a distinct tendency in some lamp factories to cling to one kind of photometer and to take little interest in improved methods. For lamp-testing is done by piece-work,

and the testers are reluctant to exchange a photometer with which they can work easily and quickly for another which might, at first, take time and trouble to use.

Heavy moving parts, even if moving with little friction, disconcert those who are accustomed to light and freely moving parts. The former must be gradually moved up to the position of balance, the latter allow quick oscillations to be made. Each method is capable of excellent work in experienced hands. Dissatisfaction has been expressed at the innumerable types of photometers, and some standard instrument has been called for. But the fact is that familiarity with a photometer is of great importance, and if the design and workmanship be fairly good, the type matters very little. A corollary is that each man declares that the photometer to which he is accustomed, or which he has invented, is the best.

General Experience with Photometric Work.—It might seem that this is the chief factor in reducing personal error, but it will be found that one who has limited experience with a particular type of photometer can do better work than a highly-trained man who tries to use an unfamiliar pattern. Familiarity with a particular photometer seems therefore to be of greater importance than mere experience in the art. The art is quickly learned, but it is probable that some persons cannot attain any high degree of accuracy.

Physical Conditions of the Observer.—It is obvious that a man who is fatigued or out of health cannot work at his best, and this applies peculiarly to photometry, because the operation depends entirely on a subjective impression. A skilful engineer who has to turn a bolt to fit a hole, working with "go" and "not-go" gauges, may be so tired or ill that he will make the diameter too small. He obviously makes a mistake and the result remains. A dyer who has to match a sample of cloth exercises a judgment very like that of a worker with a photometer, but there again the result remains, and may be reviewed on another occasion. The difficulty with photometry is that the judgment must be made when the balance appears to be obtained, and this cannot be revised unless all the conditions

are reproduced. To arrive at an accurate measurement, therefore, it should be repeated several times under the same conditions.

It is well known in experimental psychology that sensation-differences diminish after the beginning of a series of tests, fall to a minimum and then rise. This occurs in photometry. During the first stage the worker makes "sighting shots" or "gets his eye in." If he is experienced, this stage may perhaps occupy as little as half a minute, and means that the first two or three observations will often be found untrustworthy, and should be rejected. A less experienced man, or one who is in fact gaining experience, will improve in accuracy during a longer period. The second stage may persist for a long time if the work is not hurried or too continuous. If an observer confines himself to using the photometer, and dictates his readings to an assistant, or if he goes farther and deposes the reading of the scale to the assistant, he will soon become too fatigued to do exact work. Kennelly and Whiting* suggest that twenty-five observations under the latter conditions, occupying from fifteen to twenty-two seconds each, is about the largest number that can be made in direct succession without ocular fatigue. These experiments were made with the view of finding the degree of accuracy obtainable with different kinds of photometers under different conditions, and a high degree was, of course, aimed at. Each set was made under the same conditions and the mean of the twenty-five observations was taken. Six observers took part in the work, and 850 observations were made.

Besides conditions of ill-health or general fatigue, two kinds of ocular fatigue are liable to cause increased errors. One of these, due to a long succession of observations closely following each other, has been mentioned. This form of fatigue is probably connected with relaxation of the close attention necessary to form a correct judgment, and is of a subjective character; but is also associated with a distinct kind of fatigue due to a

* A. E. Kennelly and S. E. Whiting, "Some Observations on Photometric Precision," *Nat. Electric Light Association*, New York (Chicago Convention, 1908).

persistent image of the photometer screen on the retina. Useful as an assistant may be for recording results, it is an advantage to rest the eye between successive observations by reading a properly-lighted scale or noting readings in a note-book illuminated to the lowest convenient amount. To look straight at a lamp, for examining the height of a flame or the position of a filament, or even to light a pipe, is enough to make accurate work impossible until the eye has recovered, for after spending some time in a darkened room the eye becomes very much more sensitive.

Speed of Working.—Except so far as fatigue is concerned, the speed of working has not as much effect on accuracy in photometry as might be expected. With freely moving equipment a measurement can be made to an accuracy of 2 or 3 per cent in 5 or 6 seconds.

Kennelly and Whiting found that with lights of similar colour, 22 seconds was the average time taken to obtain an accuracy of 1.5 per cent with a Bunsen photometer, or 0.5 per cent with the contrast pattern of the Lummer-Brodhun. The concentric pattern, giving about 1 per cent, took about 17 seconds, and the plain equality pattern, 0.75 per cent, in 15 seconds. The observers were not all accustomed to photometric work. After some experience with a particular kind of photometer, and with arrangements for providing a very free motion of the apparatus, not much improvement in a setting is made after 10 seconds. With heavy apparatus that has to be moved comparatively slowly, a longer time is necessary.

In certain lamp factories, electric glow-lamps are tested by piece-work. This is generally carried out by girls working in teams of two, one seated in front of the photometer, adjusting it, making the observations, and reading the result either in candle-power at constant pressure, or in volts for a given candle-power; the other changes the lamps and marks them.

With a heavy photometer moved up to the point of balance, 1800 lamps can be tested in a day of $8\frac{1}{2}$ hours with a maximum permissible error of $\frac{1}{2}$ candle-power in 20, or $2\frac{1}{2}$ per cent. With a Joly or Bunsen photometer easily and quickly movable,

as many as 2500 to 3000 can be done in a day with a maximum error of $\frac{1}{2}$ in 16, or say, 3 per cent.

Colour Difference.—Kennelly and Whiting found that the superiority of the Lummer-Brodhun instrument almost disappeared when lights of slightly different colours were compared. They did not fall into the mistake so common with other writers on this subject, of using strong colours such as red and green, which may be studied for physiological or purely scientific purposes, with interesting and valuable results; but they confined themselves to such practical colours as those of a carbon glow-lamp at 4.4 watts per candle-power, and an overrun tantalum lamp at 0.93 watt per candle-power. The errors varied from 1.4 per cent with the contrast Lummer-Brodhun, to 1.94 with the Bunsen, the former occupying 16.9 seconds, and the latter 14.3 seconds. It may seem strange that since there is admittedly a greater difficulty in comparing coloured lights, the average time should be less than when lights of the same colour were compared. An inexperienced person will worry for a long time with the colour difficulty, but after a few attempts he will find that no advantage is to be gained, and no further accuracy can be secured by spending time on the comparison. If a 2 per cent error is permissible, the colour difficulty with ordinary ranges between the Hefner and an arc-lamp is surmounted with a very little practice. In candle-power photometry a sufficiently brilliant illumination of the screens can generally be obtained to avoid the Purkinje effect. In illumination photometry this difficulty cannot be surmounted, but fortunately in such work it is of no serious importance.

Steadiness of the Light.—In some kinds of photometric work, the light is perfectly steady, but in others, serious unsteadiness must be coped with. Flame standards affected by draughts are sometimes troublesome, but with ordinary care and patience favourable opportunities can be seized for good work. Inferior arc-lamps are not amenable to care, and patience must be expended, not in waiting for a steady light, but in taking as many readings as possible from which a mean may be calculated. Such unsteadiness is accidental, but the flicker

due to spinning electric glow-lamps for obtaining the mean horizontal candle-power, is considered by most lamp-makers to be unavoidable. It certainly makes the work more difficult, and therefore less accurate.

The Illumination on the Photometer.—For candle-power photometry, the amount of illumination on the photometer may generally be controlled, and matters are generally so arranged that it is about 10 metre-candles or 1 foot-candle. When the illumination is less than about 0.1 foot-candle, accuracy begins to fall off. Fig. 132 gives results of experiments made by

J. S. Dow and by A. Broca on this point.*

Dow moved a photometer head gradually until a change of illumination could be detected on one side, and then moved it in the other direction until a change could be detected on the other side. The difference between the posi-

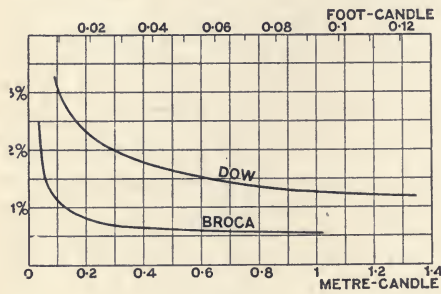

FIG. 132.

tions thus found has some relation to the mean error of a single observation, but it largely exceeds that error. In all photometric work a range can be found beyond the limits of which the photometer is appreciably out of balance. The art of exact photometry consists in the attempt to bisect this range.† The personal error of an observer is the error which he makes in this bi-section. Dow's results, and those of several other workers who have investigated the precision of photometers in the same way, must not be treated as the errors of observation.

Broca ‡ used a very different method. He employed a Masson disc consisting of a rotating white card with black dots. The dots were really small segments of black rings varying in angular width from $1/44$ or 2.27 per cent, to $1/173$ or 0.58 per cent of the circumference. Fig. 133 represents such a disc with

* J. S. Dow, *The Illuminating Engineer*, iii. 237; A. Broca, *Journ. de physique* (May 1894); and *The Electrician*, xxxiii. 753.

† Strictly, the geometric mean between the limits should be taken.

‡ *Journ. de physique* (May 1894); and *The Electrician*, xxxiii. 753.

dots for 0.5, 1.0, 1.5 and 2.0 per cent. He used a gas flame nearly equal to one carcel at distances from 1 to 5 metres. The disc being spun, the dots appeared as grey circles. With feeble illumination the fainter rings were not distinguishable. He noted the last ring visible with both eyes and with each eye separately, and found that with both eyes the results were added, or in other words, greater precision is possible with two eyes than with one.

I repeated these experiments in 1894 or 1895 and cut holes in a white disc, putting black velvet at a short distance behind, thus securing a much deeper black than can be obtained by any paint. There is no record of the results, but I remember being impressed by the importance of using both eyes in a natural manner. A drawback to an experiment of this kind is that one knows the position of the almost invisible ring, and it is difficult not to be misled by imagination. The law of decrease of visibility is well confirmed by Dow's results, and the fact that in the latter case the precision was less is fully accounted for by the different mode of procedure. A better but much more tedious way than either of these would be to make five or six sets of ten or fifteen ordinary photometric comparisons, and to take the mean difference from the mean of the observations of each set, or the probable error of a single observation. Koenig and Brodhun* have made an exhaustive investigation into this matter, but their object was to test the sensitiveness of the retina for acuity, not for an ordinary photometric balance, and they used a diaphragm smaller than the pupil of the eye, to eliminate the effect due to the contraction of the iris at the brighter illuminations. With illumination brighter than $1/10$ foot-candle, precision is slightly improved, but Broca puts the maximum at $1/175$ or 0.572 per cent, and Dow at 0.7 per cent.

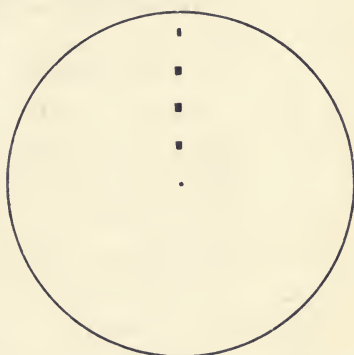

FIG. 133.

* See Liebenenthal, *Prakt. Phot.* p. 155.

Dow has also investigated the relation between acuity and illumination. Illumination measurements in ordinary street lighting can be made as low as 0.002 foot-candle with very fair precision.

When the screen of a photometer is very brilliantly illuminated it forms a dazzling patch in a dark room, and precision of measurement is difficult, though the effect is due to the black surroundings, and not to the absolute illumination. The size of the screens, or their apparent size if viewed through a microscope, has a marked effect on the error, and where differences of colour exist, this becomes a matter of some importance.*

Instrumental Errors.—From the foregoing account of personal errors it is evident that they are largely beyond control, they are constantly varying even when the conditions remain the same, and their magnitude under any given set of conditions can only be determined by investigating the deviation of a considerable number of similar observations from their mean. Instrumental errors on the other hand are constant for any given set of conditions. Some of them can be predicted by simple calculation, or they can be controlled or reduced; and for others, compensations or corrections can be made.

The most important instrumental errors in photometry have been mentioned in the section on photometers; amongst them are, stray light, unsymmetrical construction of the photometer head, departure from the law of inverse squares, introduction of artificial conditions by the use of eye-pieces or microscopes, inaccurate setting of lamps or photometer head with reference to the index on the scale. The setting of the working lamp should be watched; the filaments of some glow-lamps warp and may cause 1 or 2 per cent error.

Stray Light.—In describing the earliest known photometer, Bouguer, who invented it, speaks of the screen † between the two lights as an essential part of the instrument. Reference has been made to the use of screens, ‡ and nothing more need be

* J. S. Dow, *Proc. Phys. Soc. London*, xx. 248.

† P. 76.

‡ Pp. 134-8.

added here except the warning that stray reflected light is a most troublesome source of error. In photography, stray light finds its way from unexpected directions, but when it is strong enough to fog the plate, it leaves evidence of its existence. In photometry, on the other hand, stray light if not detected will cause unknown errors. It is possible sometimes to correct for stray light. In making the check reading of an illumination photometer before going out for an evening's work, or on coming back, it is sometimes troublesome to enclose the standard lamp so that the room is in darkness. The diffused light need not cause serious error. A measurement should be made at the measured distance with the standard lamp and the diffused light, and a piece of black card should be held so that its shadow is cast on the screen of the photometer. A reading may then be taken of the diffused light alone. The shadow should not be larger than is necessary, or some of the diffused light will be blocked out.

Stray light on any part of the photometer on which it should not fall may cause an instrumental error, if it affects one side more than the other. Or it may impair accuracy if it falls on both sides equally, thus diminishing contrast. Or if it strikes the observer's eyes through want of proper screening, it will give rise to personal error. It is difficult in some cases to distinguish between personal and instrumental errors.

Errors due to unsymmetrical construction may be avoided by the adoption of the method of substitution or double weighing.* If this is not employed, the photometer head should be reversed and the necessary constant correction must be applied to each reading, or to the mean of a set, or double measurement must be made and the means of the pairs taken.

Precision.—Finally, the magnitude of errors may be examined. E. P. Hyde,† in his investigations on the Talbot disc, made observations with such care and skill that “the average deviation of the readings for any one angle was in no case as large as 0.2 per cent; the probable errors of the measure-

* Pp. 115-20.

† *Bulletin of the Bureau of Standards*, Washington, vol. ii, No. 2, p. 27.

ments are in all cases under 0.1 per cent." C. C. Paterson at the National Physical Laboratory, writes :*

It is usual in giving photometric results to write down the fourth figure, but even in the *most favourable* circumstances this must be written small, and the value considered liable to an error of + or - 0.1 per cent.

Such precision is valuable in investigations of physical laws, or of important standards, but it would be a waste of time to attempt anything of the kind in industrial or engineering work. Kennelly and Whiting obtained from 1.5 per cent with a Bunsen, to 0.5 per cent with a Lummer-Brodhun contrast pattern, for lights of similar colour, and from 1.4 per cent to 1.9 per cent for lights of slightly different colour. In lamp factories, $2\frac{1}{2}$ or 3 per cent is an ordinary limit for lamp sorting. In street work with an illumination photometer if a number of repeated readings fall within a range of 5 or 6 per cent, or in other words, do not vary more than $2\frac{1}{2}$ to 3 per cent from the mean, the work may be considered satisfactory.

But while it is easy thus to make a general statement of what appears to be a common-sense limit of accuracy for industrial work, a serious difficulty presents itself when the question arises whether a batch of lamps is up to a specification. It would be absurd to ask that they should all be exactly 16 candle-power, so a margin is allowed, say, $2\frac{1}{2}$ per cent, that is, from 15.6 to 16.4. But if a lamp turns out to be 15.55, we are faced with a difference of 0.32 per cent. The allowance of $2\frac{1}{2}$ per cent does not help, and a further allowance is of no use. A difference of 0.32 per cent can only be discovered by an experienced man with good instruments, and a thoroughly good standard, and by taking the mean of a number of measurements. It is in fact beyond the range of ordinary commercial measurement, but the example shows how difficult it is to say what should be the limit of that range.

* *Proc. Phys. Soc. London*, vol. xxi. ; and *Phil. Mag.* August 1909, p. 267.

CHAPTER X

THE MEASUREMENT OF ILLUMINATION

Illumination Photometry.—Candle-power is concerned with the emission of light. Illumination, on the other hand, is concerned with the reception of light. A piece of white paper and a piece of black velvet placed at a distance of one foot from a source of light of one candle-power, and facing the source of light, each receive an illumination of one foot-candle. The fact that one appears brighter than the other depends of course on the reflecting powers of the surfaces. It is a mistake to say that the illumination of the white surface is greater than that of the black surface.

The candle-power photometer is an instrument for the factory or laboratory; its use is to give information about sources of light. The illumination photometer is a portable instrument for use in all places where light is used—the street, the church, the school, the house, the railway station, the railway carriage. It is not concerned with the lamps, but with what the lamps do. Nor is it confined to the use of lamps and artificial light. It can measure diffused daylight; it can give accurate information about the degree of illumination at any point, and about the distribution of illumination over any place. By measuring the illumination of a well-lighted bank, knowledge is obtained for prescribing that illumination for another bank, but the photometer does not tell whether the lamps are so arranged that the clerks' eyes are dazzled.

The photometers of L. Weber and of Mascart have been described as the first illumination photometers. This is perhaps misleading. Descriptions of these instruments were published

in 1883, but as candle-power photometers; and it seems that they were not used for measuring illumination until a later period. These questions of priority are of very little importance. Credit may be given, though he has never claimed it, to Sir W. H. Preece for the invention of the first illumination photometer. In the last of an interesting series of Reports made by him to the Streets Committee of the Commissioners of Sewers of the City of London, he wrote, in August 1884:

I made my standard the amount of illumination given by a British standard candle fixed at 12.7 inches distant. This is very easily reproduced, and it is the same illumination as that given by the French standard light when fixed at a metre distance. . . . Our instrument for the purpose must be light and portable, for it had to be moved about the streets. It required to be easily reproducible at any time and place, and to be absolutely uniform. I took my idea from the fairy lamps used at the Savoy Theatre in "Iolanthe." Here we had something portable, adjustable, uniform, and, very easily manufactured. One of these lamps was placed inside a small box, the top of which had a screen of white paper on which was a grease spot. I was able, by increasing or diminishing the current of electricity producing the light, to vary the illumination of one side of this grease spot. When it was desired to measure the illumination of any space, such as the surface of a street, this box had simply to be put at the place to be measured, and the current had to be regulated until the grease spot disappeared. The current of electricity then became the measure of the illumination, and a simple table gave the result in terms of the new standard.

Several forms of the apparatus had to be made before he obtained one which fully met his practical requirements. The method was described in a paper* read before the Royal Society on 21st June 1883.

The Preece Illumination Photometer.—Fig. 134 shows a pattern slightly modified from the one illustrated in the paper. The illumination to be measured was received on a white paper screen parallel with the Bunsen screen, and at about 12 inches distance from it. Experiments showed that the illumination corresponded closely with the sixth power of the current over a

* *Proc. Roy. Soc.* No. 229, 1884.

range of 1 to 64 in candle-power, or 6 inches to 4 feet in the distance of the calibrating lamp from the reflecting screen. The lamps used were generally Swan $2\frac{1}{2}$ -candle-power at 5 volts. As at that time there were no sufficiently sensitive ammeters or voltmeters, a differential galvanometer null method designed by Major P. Cardew was employed. The current to be measured passed through a few turns of thick wire, and the current from two large Léclanché cells passed through a coil of many turns of fine wire. Resistance boxes with plugs were arranged in both circuits, the one for controlling the candle-power of the

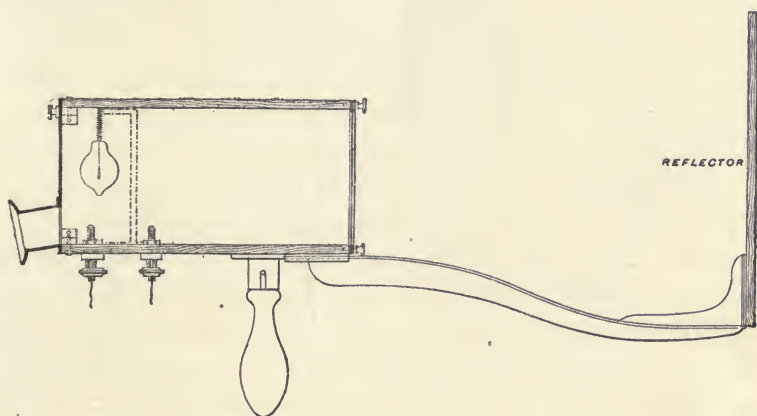

FIG. 134.—THE PREECE ILLUMINATION PHOTOMETER.

lamp, and the other for adjusting the current in the fine wire circuit of the differential galvanometer. The handling of the two sets of plugs for each measurement was tedious. The instability of a glow-lamp as a standard of light was alluded to by Preece in his original paper, but no perceptible change occurred in the course of an evening's work. The instrument was calibrated with standard candles. As the construction of the apparatus prevented the candle from being placed immediately in front of the screen, two candles were used, one on each side, and were arranged so that the angle of incidence on the screen was 60 degrees at a distance of 0.707 feet from the screen.

I had the privilege of assisting Sir W. H. Preece in his photometrical work, and helped to make many measurements

of the illumination of the streets in the City of London, some of which were experimentally lighted, and well lighted, by electric light. Arc-lamps on very tall posts were tried near the Mansion House, and Holborn Viaduct was lighted by 110-volt Edison lamps, the current being supplied from the celebrated "Jumbo" dynamo. The photometer showed that the illumination of the street fell off westwards, owing to the resistance of the mains. I regret that my note-books of that date have been inadvertently destroyed, and I cannot give details of the work.

Modern critics of illumination photometers have suggested that the apparent brightness of screens made of such material as white paper does not follow the law of cosines. Preece was quite alive to such a possibility, in calibrating his photometers. In street work, where the illumination due to several lamps was to be measured, the screen was naturally held horizontally so that each lamp should contribute its own illumination on a fair basis. The chief disadvantage of this first illumination photometer was that when feeble illuminations were measured the colour of the little lamp was too red, and with brilliant illumination there was risk of altering its candle-power by overrunning. Preece designed another photometer in which the lamp was made to approach or to recede from the Bunsen screen by means of a long screw.

Preece and Trotter Illumination Photometer.—A large number of Bunsen spots of different kinds were tried, in the hope of finding one which could be viewed satisfactorily from one side only; but eventually, in a photometer designed by Sir W. H. Preece in collaboration with myself, we used the well-known arrangement of two mirrors, allowing both sides of the spot to be seen simultaneously. The lamp was mounted in a holder sliding on a vertical rod (see Fig. 135). It was moved by a lever.

A rather strong spiral spring pulled one end of this lever and caused it to press upwards against a cam and downwards against a grooved wheel. This wheel was mounted on a nut which traversed a vertical screw. At the lower end of the

screw there was a handle and a graduated wheel. A vertical uniformly divided scale enabled the position of the nut to be read. The cam was so shaped that when the nut moved through a given distance, the lever rolled along the cam and the displacement of the lamp was proportional to the square of that distance. A sliding resistance and an ammeter were used for maintaining the constant current required to balance the unit illumination. The defect of this and of all illumination photometers which depend upon motion of the lamp is the small range attainable. In this instrument the range was only 1 to 10, but the range of the illuminations measured by us in 1883-4 was from 2.5 to 0.01 of the unit used. The instrument was mounted on a stand; the Bunsen screen was about 5 feet from the ground.

After an interval of nearly eight years, during which nobody in this country had continued the study of illumination photometry initiated by Sir W. H. Preece, I took up the matter again, and after a considerable amount of experiment made the perforated screen photometer, described on page 103.

This was used in a very primitive fashion in the London streets in the winter of 1891 with the assistance of Messrs J. Leggat, J. E. Pierce, and W. G. Wallace, then students at the Finsbury Technical College. The perforated screen formed the top of a 5-inch cube. Blackened cardboard tubes 5 inches (127 mm.) square, and from 1 foot to about 3 feet long, were fitted to the open side of the cube, and laid on the street. A glow-lamp, usually 1 candle-power or $\frac{3}{4}$ candle-power, supplied by accumulators, was set at 5 inches from the ground, so that its light could not strike the under surface of the perforated

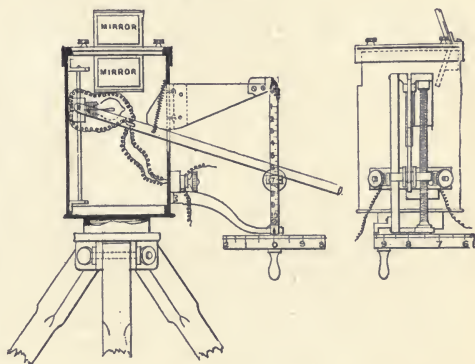

FIG. 135.—PREECE AND TROTTER ILLUMINATION PHOTOMETER.

screen. The lamp was moved until an approximate balance was obtained, and then the cube and tube were raised clear from the ground, swung by cords in the plane of the lamp, and dropped at the best point. The illumination was read off on a tape graduated directly in foot-candles. In streets lighted with flat-flame gas-burners an illumination of 0.005 foot-candle was not uncommon. This corresponds to a candle at 14 feet 2 inches (4317 mm.). A complete tube connecting the lamp with the photometer was out of the question, and errors due to stray light undoubtedly caused the readings to be too low. I therefore proceeded to experiment with different methods of diminishing the light.

In a paper by Preston S. Millar on "Illumination Photometers and their Uses," read at the first annual Convention of the Illuminating Engineering Society of Boston, 1907,* the essential features of an illumination photometer are said to be "first a photometric device; second a comparison light source; third, a means of varying the intensity of the illumination produced upon the photometric device by the comparison light source; fourth, a test plate upon which the unknown light falls." In discussing the third of these features, Millar writes:

This has been accomplished by a variety of methods, some of considerable ingenuity. These may be classified as follows:—First, variation in distance, applying the inverse square law. Second, rotating sector discs, relying on Talbot's law. Third, inclination of an illuminated surface, applying Lambert's law of the cosine. Fourth, variation of the intensity of the comparison light source. Fifth, the use of absorbing media. Sixth, the use of variable diaphragms, generally with diffusing screens. Seventh, dispersion lenses. Eighth, polarization method.

I tried most of these devices. The variation of the intensity of the source of light and the alteration in distance gave rise to difficulties which have been mentioned. Rotating discs needed, for their accurate adjustment while running, better workmanship than I could command. I made many experiments with lenses, both concave and convex, but found that a range of movement

* *The Illuminating Engineer of New York*, ii. 475.

of at least 2 feet 6 inches (762 mm.) was necessary, and it was difficult even then to produce a uniform illumination on the reflecting screen. My inner screen was $3\frac{1}{2}$ inches (89 mm.) square, and the perforated screen receiving the illumination to be measured had a star-shaped hole $1\frac{1}{4}$ inch across. The comb eclipsing device used in "dissolving views" required fully 2 feet to secure uniform illumination, and an "iris" diaphragm was no better. Photographically shaded glass screens were tried, and a pair of lenses sliding over each other. This last device nearly succeeded, but with low illuminations an image of the lenses appeared.

I finally adopted the method of inclining the inner screen at different angles. As at first arranged, the screen was mounted symmetrically on a horizontal axis and a pointer was geared to the axis in the ratio of 1 to 12. The readings for the higher illuminations were fairly good, but in spite of the gearing, the readings for low illuminations were too close together. The reflecting screen was then mounted on an axis passing through its upper edge, and motion was given to it by a fine chain wound upon a snail cam. The cam was shaped at first on the assumption that the illumination on the screen would be proportional to the cosine of the angle of incidence of the light upon it. This instrument is illustrated in Fig. 136.

In the plan showing it with the cover removed, the battery is seen on the left, the snail cam and chain (the cam being in the position for maximum illumination), and a 1-candle-power and a $\frac{1}{2}$ -candle-power lamp which could be used singly or together. The star-hole in the perforated screen is shown by dotted lines. On the right there was a compartment for spare or experimental screens. The sectional elevation shows the slope of the movable inner screen in the position for maximum illumination, and dotted lines show it in other positions. The instrument was about 6 inches high and was always placed on the ground. The star-hole was viewed directly from above. The dial, which is not shown in the illustration, was graduated almost completely round a circle,

with an open but not quite uniform scale. It was of course calibrated by experiment. The cam was turned by a removable handle about a foot long, to save much stooping. Illumination from any direction except immediately overhead could be measured. Most of my work in the streets of London in the winter of 1891 and the spring of 1892 was done with this instrument.

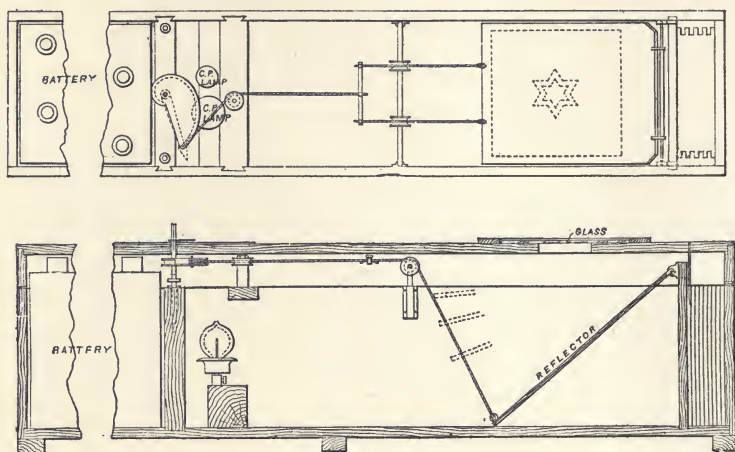

FIG. 136.

Millar's Criticisms on Illumination Photometers. — The paper by P. S. Millar, to which reference has been made, differs greatly from the colourless descriptions of Palaz, Liebenthal, and other writers, by reason of his keenly critical comments on and comparisons between the various patterns of instruments. With reference to the method of varying the illumination by a turning screen, he writes :

The variation of the inclination of a plane with reference to the light incident upon it, or to an angle at which it is viewed, is an unsatisfactory method ; first, because unless a perfect diffusing surface is obtained, the cosine law will not apply, and the instrument should be calibrated empirically ; second, because any surface which approximates to a perfect diffusing surface is likely to change in character, which would introduce an error into the scale calibration of the instrument ; and third, because the scale calibration of an instrument in which this

is used becomes very narrow with low intensities, so that the slightest displacement of the plane will produce a marked difference in the illumination in the region where the photometric comparison is rendered difficult because of the low intensity which is being studied.

Millar states his preference for the variable distance method, which he considers far superior in that it possesses "accuracy, reliability, ease of verification, calibration according to a known law, simplicity, a wide range, and universal application." It is true that several illumination photometers have been proposed, in which the variable distance method is used, but the range, as has been already observed, must be very limited if this alone is employed. The lamp cannot be brought nearer than about 6 inches (152 mm.) from the screen without risk of a departure from the square law, or unequal illumination of the working part of the screen. In order to reduce the illumination to $1/50$, the lamp must be moved to a distance of more than 3 feet 6 inches (1070 mm.), and to reduce it to $1/200$, it must be moved to more than 7 feet (2.1 m.). No illumination photometers in which the variable distance method is used, are able to measure directly the feeble illuminations found in ordinary street lighting, such as 0.003 foot-candle, without supplementing the method of reducing the illumination by absorbing screens or some such device. The upper limit should be at least 2 foot-candles, and preferably 4. I find that Millar's criticisms, useful as they are, do not condemn the rotating screen. In the first place, the "perfect diffusing surface" is quite unnecessary. Any piece of ordinary fairly white cardboard will do. All such instruments must be graduated by experiment, and the moving screen need not obey the cosine law at all. The only matter to be observed is that there should be no considerable glaze, and that it should not be used near a position in which the angle of incidence of the little lamp in the photometer is nearly equal to the angle of emission or view. Secondly, while it is desirable that the movable screen should not be made of a material easily soiled, or likely to change, error due to this

is easily detected when the instrument is checked. Such a check should be frequently made to keep a watch on the condition of the accumulator and of the lamps, and of the contacts in the circuit. I always checked my instruments against a standard before going out for an evening's work, and generally again on coming home. Millar's third difficulty is entirely avoided by the use of a cam or a system of levers which expand the scale at the low readings.

*Trotter Illumination Photometer.**—The instrument shown in Fig. 136 presented the disadvantage that it could only be

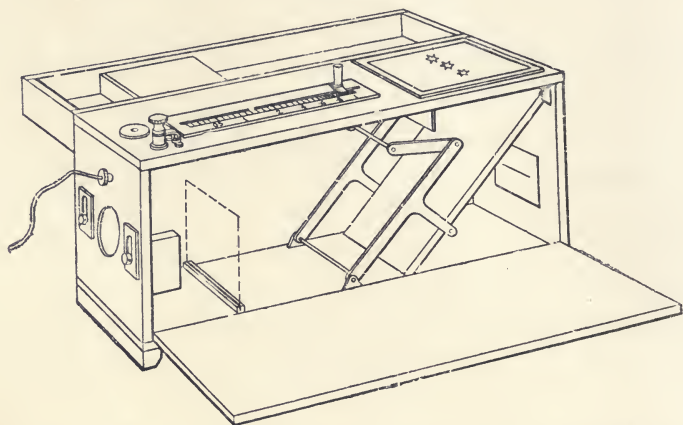

FIG. 137.—SECOND PATTERN TROTTER ILLUMINATION PHOTOMETER, 1895.

used in a horizontal position. It is convenient in calibrating the scale and in checking it, to turn the instrument on its side, with the perforated screen vertical. In 1895 I designed a photometer which was described in a paper contributed by Sir W. H. Preece and myself to the British Association.† The small cam and chain of the 1891 pattern were replaced by a system of levers.

This is shown in perspective in Fig 137 and in side elevation in Fig. 138. In the latter illustration the lamp is shown

* As little of Preece's invention remains except the use of a horizontal screen and a small electric lamp, and since I can find no convenient name to describe a photometer having a perforated external screen and a moving internal screen, I must adopt the name by which it has generally been known, viz. the Trotter Illumination Photometer.

† *The Electrician*, xxxv. 671 (1895).

on the left, and the movable screen, shown in full lines resting on a roller, is in the position of minimum illumination, the light just grazing along it. The handle by which it is moved is at the right-hand end of the straight scale. The dotted lines in Fig. 138, and the view in Fig. 137, show the screen and levers in the position of maximum illumination. The hook provided at the lower side of the movable screen held it against the roller when the instrument was turned on its side. The proportions of the system

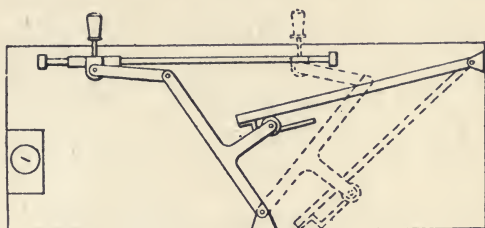

FIG. 138.

of levers were so designed that the scale, instead of becoming closely contracted at the low end, was considerably expanded, as is shown in Fig. 139. The scale was $5\frac{1}{4}$ inches (133 mm.) long.

Low Readings and Zero of the Scale.—It will be observed that the zero is absent. Considerable care is necessary both in the design and in the construction of an illumination photometer, to secure really low illumination such as $1/1000$ or $2/1000$ foot-candle. It is, of course, possible to shut the light completely off the screen, and leave it in complete darkness, and so to arrive at zero, but that serves no useful purpose.

At the lowest illuminations the light nearly grazes the screen, and as Millar observes, the slightest displacement of the screen will produce a marked difference in the illumination.

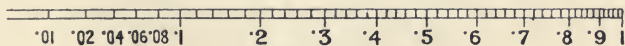

FIG. 139.

So far as the motion of the screen is concerned this need cause no difficulty if a well-devised and well-made mechanism is used for connecting the pointer with the screen. But a more serious difficulty arises in the replacement of the lamp by another, for the filament of the new one should occupy the position of the old one, and with special exactness, in the plane of the minimum

position of the movable screen, or the scale would have to be re-calibrated.

Adjustment of the Lamp.—In all the photometers which I have made or have designed in detail, I have used simple straight filament lamps, miniature tube lamps, or “festoon” lamps, or “horse-shoe” or “hair-pin” lamps with good straight parallel limbs. In order to fix a new lamp in the true position, a sheet metal screen shown by dotted lines in Fig. 137 was set in a holder attached to the bottom of the box. Two small holes were drilled in this screen, one for each lamp. A white paper screen having a black horizontal line was fastened to the end of the box opposite the lamps. The movable screen being lifted out of the way, “pin-hole images” of the filaments could be thrown on this screen. When “horse-shoe” filaments were used the lamps were so set that the image of the limbs was nearly closed up and the thin dark line between the limbs was made to fall on the black line. The images being magnified, considerable accuracy was possible. The clamping screws for the special lamp-holders are seen outside the box in Fig. 137. The box was 1 foot $3\frac{3}{4}$ inches by $5\frac{1}{2}$ inches by $9\frac{1}{2}$ inches high (400 mm. by 140 mm. by 241 mm.). The middle of the screen was about 11 inches (280 mm.) from the lamps. Several of these photometers were made by Messrs. Nalder Bros. and Co.

The Nalder-Trotter Illumination Photometer.—During my stay at the Cape of Good Hope, 1896-9, certain modifications of the perforated screen photometer were made by Nalder Bros. and Co. A Hefner amyl-acetate lamp with an ingenious wind-guard was used instead of the electric lamp, and a curved movable screen was employed. I have never used this pattern, and was not favourably impressed by it. I was less inclined to criticise it after seeing the very useful work done with it by Mr. H. Fowler, who read a paper* on *Lighting of Railway Premises; Indoor and Outdoor*.

The origin of this modification seems to be that Nalder Bros. and Co. distrusted the ability of a portable accumulator to maintain a sufficiently steady supply, and considered the question

* H. Fowler, *Proc. Inst. Mech. Eng.*, 1906, p. 867.

of a portable ammeter and a regulating resistance. Knowing that 2 per cent variation of light of a carbon lamp is produced by a variation of 0.3 to 0.4 per cent of the current, their knowledge of electrical measuring instruments showed them that a portable ammeter of this precision was out of the question. They therefore turned their attention to the use of a Hefner lamp, and appear to have succeeded in guarding its very sensitive flame against draughts. Considering the size of the flame and its proximity to the movable screen they seem to have made the best of a very difficult task. The manufacture of this pattern has been discontinued.

Later Pattern Trotter Illumination Photometer.—A few months before the reading of Fowler's paper I was asked to recommend an illumination-photometer, and no pattern of my design being on the market, and all the patents lapsed, I made a number of experiments with the view of improving on previous models. Several kinds of curved screens were tried with the view of extending the scale without further mechanism, but these were not satisfactory, and I returned to the use of a snail cam and chain, and made an instrument which I showed at the discussion on Fowler's paper* at the Institution of Mechanical Engineers.

This pattern is illustrated in Fig. 140. The lamp with a single straight filament is seen end on at A. It was supplied by the accumulators BB. The light passed through a slit in a partition, thus cutting off stray light. The movable screen C was pulled counter-clockwise by a long thin spiral spring not shown in the illustration, and was pulled clockwise by the fine aneroid chain D, which was wound up on the little snail cam E. A pointer moving on a graduated dial was fixed to the spindle carrying the cam. The illumination to be measured was received on the screen G. Three narrow slits were cut in this, and the screen C was seen through them. The cam E was turned until the middle slit was as little visible as possible. As soon as the best balance was obtained, the lamp was switched off, and by

* *Proc. Inst. Mech. Eng.*, 1906, p. 991. This illustration is reproduced by permission of the Council of the Institution.

the same movement, a clamp F held the spindle and pointer in position. This was necessary because the spindle was very free to move. The perforated screen was of Bristol board, the glaze having been removed with a damp cloth. The movable screen was of fine ground glass, held up against the rebate of a metal frame by a spring at the back. The dull surface was the one seen, the other side was painted with oil paint. This makes an excellent screen, for it is flat and cannot warp. It is

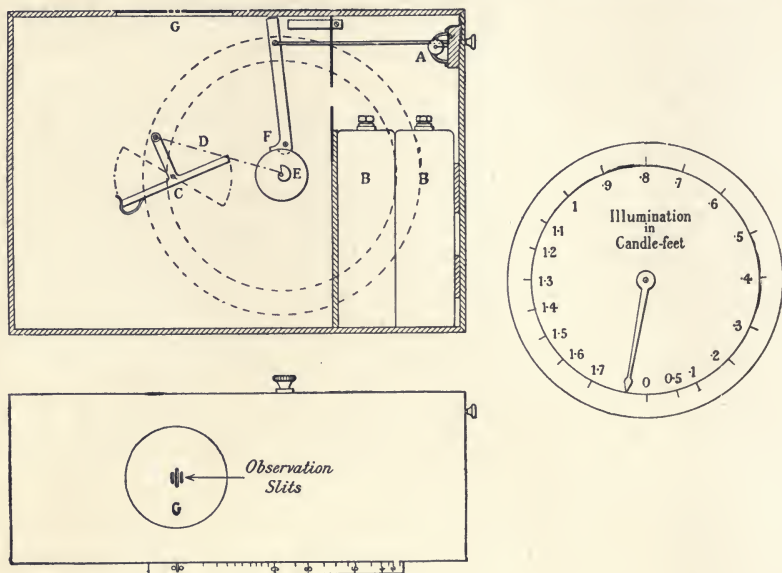

FIG. 140.

easily cleaned, and can be tinted any colour. The method of fixing it is independent of the thickness. Another screen may be substituted with the certainty that the ground surface will occupy the same plane. It is necessary to prevent light from striking the edge of the glass when it is nearly in the grazing position. Regarding warping as a slight displacement of the screen, Millar's warning that this will produce a marked difference at low illuminations is well justified.

Everett, Edgcumbe's Pattern of Trotter Illumination Photometer.—I did not use the photometer illustrated in Fig. 140, but handed it to Messrs. Everett, Edgcumbe, and Co. They

have made a considerable number of instruments and have introduced several modifications, some of them being marked improvements on my model. Fig. 141 shows one of their

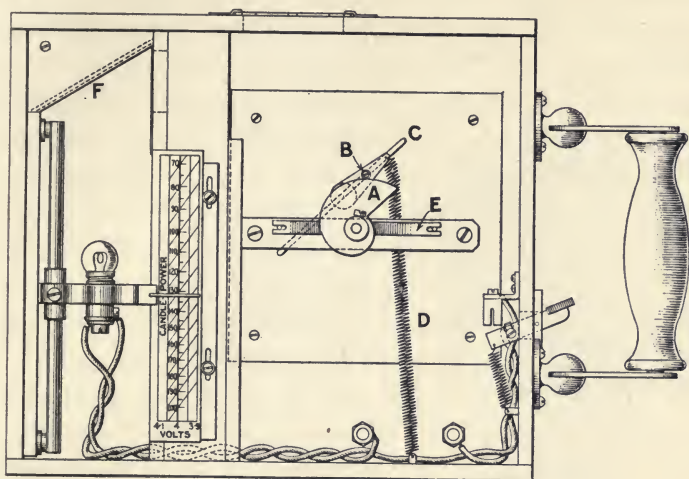

FIG. 141.

earlier patterns. The snail cam A is retained, much enlarged, and therefore more accurately shaped. Instead of the chain, a little roller B attached to the movable screen C bears directly on the edge of the cam, pressed against it by the long spiral spring D. A light leaf spring E is provided, which while giving just enough friction to hold the screen in any position allows a very free motion. Owing to the workmanship and the design, the motion of the mechanism is superior to any of my previous instruments, and, to use the words of Count Rumford, is "perfectly soft and gentle." The cam is shaped so that the scale (Fig. 142) is divided somewhat like a slide-rule, the graduations for the high illuminations are crowded together, but are more open at the lower end so that feeble illuminations can be accurately measured.

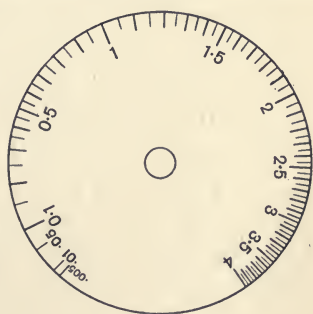

FIG. 142.

Two modifications introduced by Everett, Edgcumbe, and Co. are departures from my previous designs. The light from the lamp does not fall direct on the movable screen as in all the other patterns, but passes upwards to a mirror, F, and is reflected to the screen. This saves space and gives facility for an ingenious adjustment of the lamp.

Direction of View.—The other departure is the direction of view of the observer. I always observed the perforated screen from a point immediately above it. It is necessary to fix some point or rather direction of view, and I chose the vertical one partly because the spot below a lamp is often occupied by a lamp-post or is in shadow, and partly because with an inverted lamp the illumination in the neighbourhood of the point on the ground immediately below it does not vary much.

The perforated screen or test-plate has a single slot and it is viewed at an angle of about 20 degrees with the vertical. When the eye is in the right plane the knob by which the pointer is turned is in a line with the slot in the screen. The movable screen is mounted in a frame and two small black pointers are fixed at the axis on which it rotates. Viewed in the right plane, one or other of these pointers may be seen through the slot if the observer's head is moved a little to one side or the other. Fig. 143 shows a movable screen and pointers; the slot in the perforated screen is shown by dotted lines.



FIG. 143.

The makers at first supplied a screen with a slot 4 mm. by 30 mm., but I found that while this gave good results for any illumination down to about 0.005 foot-candle (0.0554 metre-candle), much lower illuminations can be measured with larger perforations, as in my earlier photometers. With a star hole as in Fig. 77, about 23 mm. ($\frac{7}{8}$ inch) from point to point, or with a wide slot 15 mm. by 30 mm. ($\frac{5}{8}$ inch by $1\frac{3}{16}$ inch), it is possible to measure down to about 0.0001 foot-candle (0.0011 metre-candle), or a candle at 100 feet (say 30 m.). For such measurements a resistance is added in series with the lamp.

The chief reason for abandoning the perpendicular direction of view was the proposal by the makers to use the photometer for measuring candle-power as well as illumination, and having adapted it for that purpose, they gave it the name "universal." The perforated screen is set directly facing the lamp when candle-power is to be measured, thus simplifying the calculation; and folding shutters or "blinkers" are provided to screen off other lights. To set the screen in this position, the photometer is mounted on a tripod with a pivoted and hinged head, enabling the instrument to be turned in any direction and fixed at any angle. Since the screen faces the light, the direction of view must be other than perpendicular to it, and an angle of 20 degrees has been chosen.

Adjustment of the Lamp.—The lamp is clamped to a pillar. In some cases two lamps and two pillars are used to give a greater range. In order to give facility for handling them they are then attached to the lid and not to the box. The lamp carries an index which points to a scale of candle-power. When the lamp occupies a position corresponding to its own candle-power, the instrument is direct reading in foot-candles.

Provision is made on the scale for allowing for slight variation of voltage. But this is of doubtful value, for any good two-cell accumulator discharged for a short time before using will give 4 volts with great constancy. If the lamp is switched on only while a reading is being taken (and 15 seconds is ample for this), the total discharge during an evening's work will not amount to more than 20 or 25 minutes. If at any time a new lamp is fitted, the instrument should be carefully checked with a good sub-standard of light of, say, 1 candle-power at a distance, say, d feet, the lamp being set directly facing the perforated screen. After obtaining a photometric balance the



FIG. 144.

reading on the scale should be $1/d^2$. If, however, instead of this, the dial reading should be, say, 5 per cent too high, the lamp inside the photometer should be moved upwards (that is, nearer the mirror) by 5 per cent on the scale.

If the lamp gives so white a light that the slot appears blue and the screen yellow, a balance is more difficult to obtain, and at illuminations below 0.05 foot-candle the readings may be too low owing to the Purkinje effect. A lamp should be chosen for the class of work to be done, or a resistance may be added, making the light dimmer and more yellow. A correction for the scale readings must be made.

The Screens.—Everett, Edgcumbe, and Co. have substituted for the Bristol board, which I have used for so many years, a white celluloid composition. So long as this is thick enough to ensure that it will not warp, it seems to be an excellent material. The character of the surface of the movable screen is of no consequence so long as it does not change in shape, seeing that the scale is graduated by experiment, but the surface of the perforated screen is of great importance.

Two kinds of angle errors may arise from a perforated screen of an unsuitable surface. If it is at all shiny, and the light from a lamp falls upon it at an angle of incidence equal and opposite to the angle from which the screen is observed, the glare will add to the apparent brightness, and the photometer will read too high. On the other hand, if the illumination received by the perforated screen falls on it at a considerable angle, when the surface is not suitable, the cosine law will not hold good. I find that an excellent surface can be obtained on this white celluloid by finely powdered pumice rubbed on with a ground glass rubber and plenty of water.

Millar* discusses what he calls the test-plate with great minuteness and considers that there is no material which meets all his exacting requirements. Discussing as he does many different kinds of illumination photometers impartially and thoughtfully, he considers that the test-plate should not be viewed from above, "because it would necessitate interference

* *The Illum. Eng.*, New York, ii. 477.

with light which would otherwise fall upon the test-plate. It follows, therefore, that the correct method is to consider transmitted light from a point directly beneath the test-plate. . . . This means that all instrument parts, as well as the observer, must be beneath or behind the test-plate. This is possible only when transmitted light instead of reflected light is measured." It is true that in some illumination photometers, such as that of Dr. Martens, the test-plate is placed in an unfortunate position, but in the course of a rather extensive practical use of my photometers, I can remember only one occasion on which I was inconvenienced by my own shadow. This was in the South Kensington Museum. In one court I was surrounded by ten arc-lamps. I stood a short pencil upright on the screen and counted the radial shadows. I walked round and noticed in what positions of my body any of these shadows disappeared, and thus found a direction in which all ten were present.

Angle Errors.—From my earliest experiments with Sir W. Preece in 1883 and throughout my work in 1891-2 I always measured illumination on a horizontal screen. There has been much discussion about this practice, and the matter will be examined in a future section. Meanwhile it is sufficient to admit that on a horizontal plane at some distance from a lamp, and therefore with a considerable angle of incidence, the illumination is much more feeble than if the plane were tilted to face the lamp. Two kinds of error may arise, one due to a slight inaccuracy in levelling, and the other due to the nature of the material of which the screen is formed. The former may be dismissed for the present.

It is obvious that if the surface of the screen is not perfectly matt, there will be some specular or regular reflection when the angle of incidence is equal to the angle of view, but it has been suggested also that with most substances there is a wide departure from Lambert's cosine law at large angles of incidence. This allegation is not well expressed, for the cosine law is a question of illumination received, not of light emitted or of apparent brilliance. The emission of light from matt surfaces,

or the law of diffused reflection, has been discussed by Bouguer, Wiener, Blondel, and other writers, and I hope soon to contribute something to the knowledge of this subject. In the present case the matter is somewhat simplified by the fixity of the angle of view or angle of emission from the perforated screen.

In the course of my investigations of the law of diffused reflection I have not found with such a material, for example, as white celluloid, either well matted or half glazed, that there was any appreciable error at large angles of incidence. There are several experimental difficulties in making the measurements with smaller errors than 1 or 2 per cent, and within such limits no systematic error was found. On the other hand I have examined a celluloid screen which had been in practical use for some months, and had been repeatedly cleaned. It might have been better if it had been allowed to become dirty. That could have been taken into account by a simple correcting factor found by the usual check measurement. I found that under certain circumstances not likely to occur often in practice, the error due to the partially glazed surface might amount to 20 per cent. But even with this obviously imperfect screen the maximum error might be reduced to about 5 per cent by proper placing of the instrument.

Error due to Glaze.—Appreciable angle error due to want of perfect mattness, or in other words to a slight glaze on the surface of the screen, can only occur when the light falls at an angle approximately equal to the angle at which the screen is viewed—in this case, about 20° . Fig. 145 shows the worst position in which a worker can place himself and the photometer with respect to the light. If the photometer is turned through a right angle, and the light falls sideways, the error will be a minimum.

Measurement of Angle Errors.—The screen of a photometer may be tested for angle error by mounting a suitable lamp on a radial arm. The axis on which it turns must pass exactly through the slot of the screen. If the screen is viewed in the plane in which the radial lamp revolves, the view will be blocked by the lamp, or the observer's head will intervene

between the lamp and the screen when the light from it falls at 20° incidence or thereabouts. If the screen is viewed cross-wise with this plane, a complete semicircle of readings can be obtained. In testing such screens I have used a specially constructed apparatus, not depending on a moving screen with a cam and a calibrated scale, but on the motion of a lamp on an ordinary photometer bar. The light from this lamp fell on a fixed inner or back screen, visible through the slot in the screen under test. The illumination on the back screen was a measure of the brightness of the perforated screen when a photometric balance was effected.



FIG. 145.—WORST POSITION.



FIG. 146.—BEST POSITION.

The matter will be perhaps better understood if the case of the badly-glazed screen, to which reference has been made, is taken first. Fig. 147 is a polar diagram of the observations. The line of view was in the plane in which the lamp revolved, this being the worst position. The angles represent angles of incidence of the light from the radial lamp, and the radii are observed brightness, when viewed at 20° . The apparatus was adjusted with the intention of obtaining an illumination of 100 as measured on the photometer bar; when the incidence was 0° , the actual reading was 99, but the general direction of the curve suggests that this was about 1 per cent too low. For the present purpose of considering the departures from the cosine law as instrumental errors, the brightness at 0° may be

taken as 99, and the departures may be taken as excess or defect. On another occasion I propose to discuss the law of diffused reflection in a different manner. Since the object of the tests of this glazed screen was only to obtain the general shape of the curve, a single observation only was made at each angular position; errors of observation amounting to about 1 per cent are present.

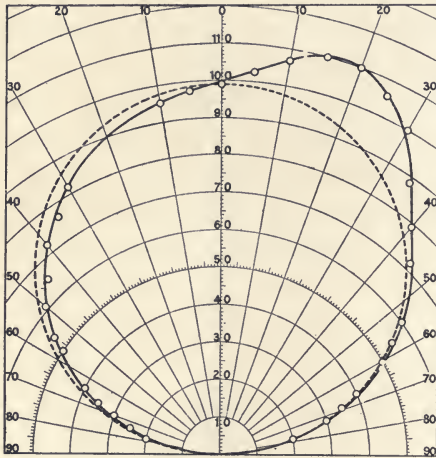

FIG. 147.—BADLY GLAZED SCREEN IN WORST POSITION.

Assuming for the present purpose that 99 is the true value at 0° incidence, the dotted circle (Fig. 147) represents the cosine law; there is a positive error or excess of 16 per cent at 20° when the reflection due to the

glaze is a maximum as in Fig. 145. Between 45° and 60° on the same side, which may be called the front side, since the lamp is in front of the observer, there was a fairly constant excess error. At 20° on the other side the view was blocked by the lamp. From 30° to 70° on the back side there was a deficiency of about 0.04 foot-candle. At 30° this error is equivalent to about 5 per cent, and at 70° , the deficiency being about the same, was equivalent to nearly 22 per cent.

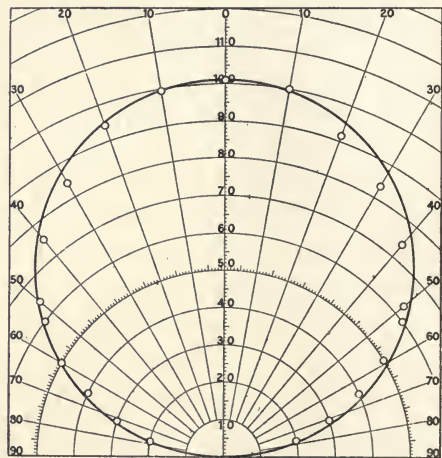

FIG. 148.—BADLY GLAZED SCREEN IN BEST POSITION.

Fig. 148 is a similar diagram of the errors of this badly glazed screen in the best position, that is, viewed at right angles

to the plane in which the lamp revolved (Fig. 146). The errors of observation were a little larger, but an oval or ellipsoid such as has been described by Bouguer and others would represent the curve.

The errors are all in defect if the observation at 0° incidence is assumed to be correct. At 40° it is about 0.02 foot-candle, or 5 per cent.

Fig. 149 is a similar diagram of a well-matted celluloid screen viewed in the worst position. The divergencies from the cosine law are so small that they cannot be clearly shown on a diagram, but they can be shown better numerically.

The first column of the following table gives the angles, θ . From 78° to 40° the lamp on the photometer bar was set to a round number, and the angle of the radial lamp was adjusted to give a balance. From 40° to 0° the angle was adjusted to a round number, and the lamp on the bar was adjusted to obtain the balance. The readings on the bar give E the observed brightness. These readings are set out in the second column. For the present purpose the reading at 0° incidence (namely 105) is regarded as correct.

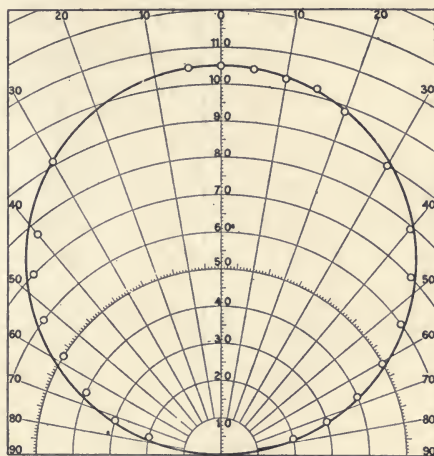

FIG. 149.—GOOD SCREEN IN WORST POSITION.

[TABLE

	θ	E	$105 \cos \theta$	Diff. %	
Back.	77	20	23.6	-18	
	72	30	32.4	-8	
	$65\frac{1}{2}$	40	43.6	-9	
	$58\frac{1}{2}$	50	55	-10	
	$52\frac{1}{2}$	60	64	-6.6	
	$46\frac{1}{2}$	70	72.4	-3.4	
	40	77.3	80.5	-4.2	
	30	91	91	0	
	20	blocked			
	10				
Front.	5	105	104.5	+0.5	
	0	105	105	0	
	5	104.5	104.5	0	
	10	103	103.4	-0.4	
	15	102	101.4	+0.6	
	20	98.5	98.8	-0.3	
	30	90	91	-1.1	
	40	79.5	80.5	-1.3	
	47	70	71.6	-2.29	
	54	60	61.8	-3.0	
	$60\frac{1}{2}$	50	51.8	-3.6	
	67	40	41.0	-2.5	
	72	30	32.4	-8	
78	20	21.8	-9		

The first difference of 18 per cent seems to be serious, but it would be accounted for by a difference of angle of 2° . The experimental difficulties at large angles of incidence are con-

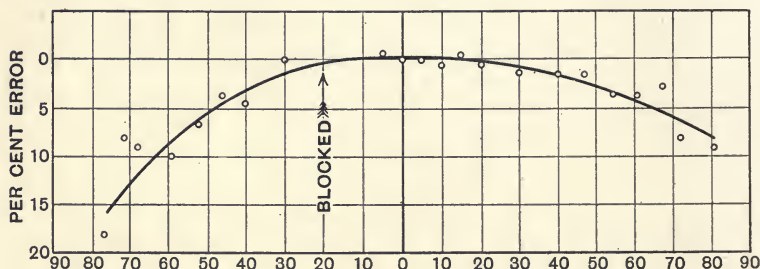

FIG. 150.—GOOD SCREEN IN WORST POSITION.

siderable. The graphical plotting as in Fig. 149 is quite unsuitable for showing the departure from the cosine law at large angles. The departure from the cosine law on the

assumption that there is no error at 0° incidence is, however, negligible for all "front" angles down to about 70° .

With a well-matted celluloid screen in the best position,

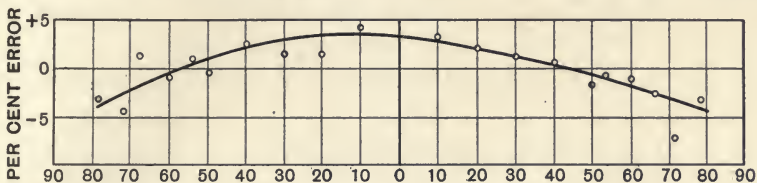

FIG. 151.—GOOD SCREEN IN BEST POSITION.

(see Fig. 146) the systematic errors from 70° on one side to 70° on the other do not exceed more than about 3 per cent, or the ordinary errors of observation for outdoor industrial photometry.

Fig. 150 is the same as Fig. 149, but plotted as errors per cent. Fig. 151 is a similar diagram for a good screen in the best position. The whole of the observations have been recorded. Three or four of them are obviously 2 or 3 per cent wrong.

Scale of Angles of Incidence.—The outside view of the instrument given in Fig. 152 shows a graduated quadrant, and at the centre from which this is struck, a little pin is provided. This acts as a style or gnomon; its shadow falling on the quadrant enables the angle of incidence of the light of any lamp to be read. In addition to this a circular spirit level is let into the top, flush with the case. In some instruments I have added a scale of cosines, for facilitating candle-power measurements.

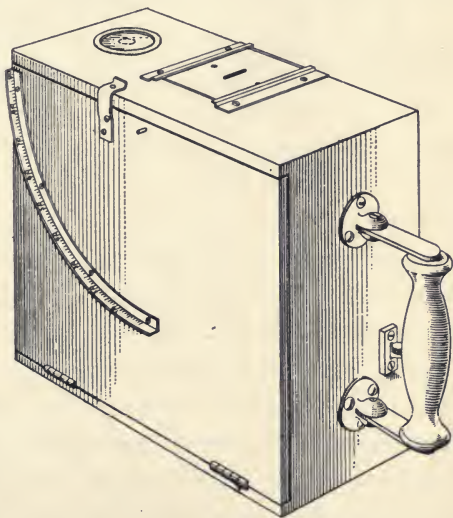

FIG. 152.—GENERAL VIEW OF OUTSIDE OF EVERETT-EDGCUMBE INSTRUMENT.

Everett, Edgcumbe, and Co. enclose a little steel ball behind

the glass of the dial. This runs freely and acts as a pointer on a semicircular scale of degrees.

Reference to Table I. in the Appendix; or to Fig. 13, page 32; or to Fig. 17, page 36, will show that at a point midway between two lamps placed at a distance apart equal to six times their height, the angle of incidence is about $71\frac{1}{2}$, and the illumination due to each lamp is only about 0.03 of the maximum (assuming uniform candle-power in all directions). Practical measurements of illumination cannot usefully be carried further than this. At these large angles of incidence, the photometer must be carefully levelled. A theoretical difference of 10 per cent in the illumination of the screen is made by a difference of one degree of level from 79 to 80, or by two degrees from 69 to 71, or by three degrees from 60 to 63. Besides these theoretical errors, which can be read off direct on a slide-rule, there is probably a distinct departure from the cosine law with all practicable materials for the screen. On the other hand in actual practice in the street it will often be found that the measured illumination is not materially affected by inclining the photometer some 4 or 5 degrees in one direction or the other. The light lost from one lamp is compensated for by light gained from the other, and stray light reflected from buildings contributes to this unexpected result.

Measurement of Candle-power.—Following on the lines laid down by Preece in 1883,* my early work was confined to the photometry of illumination, and that on a horizontal plane. I rarely measured candle-power. The public and the street-lighting authorities are concerned only with illumination, but the engineer and contractor who has to supply the illumination has to consider candle-power as well.

To measure candle-power with an illumination photometer, the first step must be to find the vertical height of the lamp

* "We do not want to know so much the intensity of the light emitted by a particular lamp, as the intensity of the illumination of . . . the surface of the streets and of the pavements . . . we want to know in fact the degree of illumination due to the emitted light, not the intensity of the rays of the source of light."—Preece, *Report to the Commissioners of Sewers of the City of London*, 1884.

above the ground. To obtain this, set the photometer at such a distance from the lamp that the shadow of the pin falls on 45° ; the case being level. Measure the horizontal distance from the lamp to the pin, and from the pin to the ground. The sum of these is the actual height of the lamp. This can be measured without difficulty to about 2 per cent, say 3 inches in 12 feet 6 inches.

The limited range of angles possible by setting the photometer at different distances in the street does not admit of a complete measurement of hemispherical candle-power, but it comprises most of the useful candle-power emitted. With a horizontal photometer the calculation is as follows:—In Fig. 153 H is the height of the lamp, h the horizontal height of the photometer screen from the ground, and D the horizontal distance of the screen from the lamp.

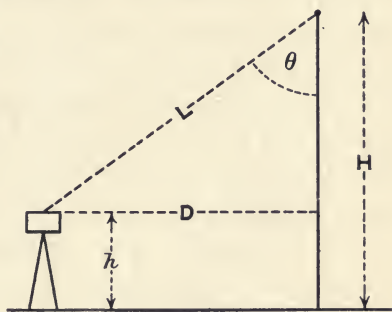

FIG. 153.

$L = [H - h] / \cos \theta$ or $L = \sqrt{D^2 + (H - h)^2}$, and the candle-power is $(I \times L^2) / \cos \theta$, where I is the illumination in foot-candles.

It may be observed that when the square of the slant height L in feet is equal to the cosine of the angle of incidence, the scale graduated in foot-candles becomes a scale of candle-power, and when the square of the distance in feet is 10, or 100, or 1000 times the cosine, the multipliers 10, 100, or 1000 may be used to convert it into a scale of candle-power. The square of the slant height being known, the photometer may be tilted until the required cosine is indicated on the quadrant by the shadow of the pin. If the slant height is measured by the sum of the squares of the horizontal distance and the height, the square is at once obtained.

The pivoted mounting shown in Fig. 144 allows the photometer screen to be set exactly facing the lamp to be measured. This eliminates the cosine factor, and the illumination in foot-

candles simply multiplied by the square of the distance in feet from the photometer to the light, gives the candle-power.

The Battery, Switch, and Contacts.—A two-cell accumulator supplying a four-volt lamp is used in connection with the photometer. Even an inveterate anti-motorist must admit that we owe to the modern motor-car the development of excellent portable accumulators. Transparent celluloid cells are best, for the free liberation of gas which indicates the completion of the charging can be seen. Some cells contain floats which roughly indicate the state of the charge. When fully charged, a pair of cells gives about 4.1 volts, but if left running at the normal rate of discharge for 10 to 15 minutes they settle down to a steady pressure. This depends on the rate of discharge and on the internal resistance. It is very nearly 4 volts. It is better to use an old lamp or a resistance for running off the first part of the discharge of the battery, for this saves the use and over-running of the photometer lamp. The capacity in ampere-hours at the normal rate is generally marked on the cells, and this should never be exceeded, but it is not likely to be reached in a long evening's work if the lamp is only used when a measurement is being made.

With so small an electric pressure as 4 volts, the slightest imperfection of contact makes a serious difference in the current. The use of bayonet or loop contacts for the lamp is out of the question. A screw socket is good if it is well screwed home, but soldered connections are better. In my earlier photometers the accumulators were carried in the instrument, but I find it is better to provide a separate accumulator and flexible conductors. If these wires are carefully used and inspected, no error need arise. The instrument is more portable if the accumulators can be carried with one hand and the photometer in the other, but it is better not to disconnect them at all except for charging. The terminals of the accumulator must be clean and well screwed up.

The switch is a likely place for a bad contact. There is a great temptation to use a switch which lights up the lamp when it is depressed, and flies up with a spring when it is released.

This, of course, prevents the wasteful running of the accumulator, but if the contacts are loose enough to allow the switch to fly off, it is very likely that they will not give exactly the same degree of contact every time. This can be tried during the check test which should precede every evening's work, and which should be repeated if possible at its close.

The weight of Everett, Edgumbe, and Co.'s pattern is only 4 lbs. (1814 gms.); the accumulator weighs 6 lbs. (2720 gms.), and a tripod as light as $1\frac{1}{2}$ lbs. (680 gm.) can be provided. It is perhaps unwise to use a flimsy tripod. One with a shelf to carry the accumulator stands more firmly, and reduces the chance of a general wreck by an accidental entanglement with the flexible wires in street work. It is quite possible to do useful work without a tripod, the photometer being merely held like a hand camera. The battery should be then slung over the shoulders with a strap. The constancy of such an accumulator was impugned by a writer in *The Electrician*, and I therefore carried out a test which is fully described in that journal.* During a run of thirty-four hours the accumulator was discharged at half an ampere for ten seconds once every minute. The fall was perfectly steady at the rate of 0.05 per cent per hour.

Height of the Photometer.—With the exception of the instrument illustrated in Fig. 135, page 203, in my early work I always placed the photometer on the ground. This seemed to be the obvious way of measuring the illumination received by streets and pavements. The photometers with eye-pieces, such as the Mascart, Weber, and most modern continental instruments, on the other hand, have, naturally, been used on stands at a height of about $1\frac{1}{2}$ metre. In recent work in this country with my photometer and that of Haydn Harrison, a stand has been used, and the usual height of the photometer screen is from 3 feet 6 inches (1.060 m.) to 4 feet (1.22 m.) from the ground. Most workers prefer to keep the screen at some distance from the eye, in order to obtain a good general view of it.

* *The Electrician*, lxvi. 552, 1911.

The effect of the height of the instrument on the illumination received by it is easily calculated for a theoretical case in which the candle-power of the lamp is uniform in all directions. Let the lamp be 19 feet from the ground, and the photometer screen, in one case 1 foot, and in the other 4 feet, from the ground. The lamp will then be 18 feet or 15 feet above the screen when the instrument is placed immediately beneath. The illumination in the former case will be $15^2/18^2$ or 0.695 of that in the latter. This appears at first sight to be a serious matter. Fig. 154 shows the curves of distribution of illumination in the two cases. The upper one having a maximum ordinate of unity represents the case of the photometer 4 feet from the ground. This is

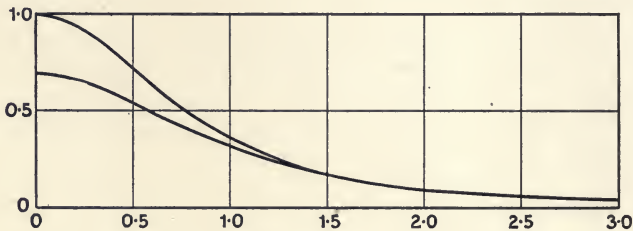

FIG. 154.

simply the cosine cubed curve which appeared so often in Chapter III. with the convention that the lamp is at unit height. In the lower curve which represents the illumination on the screen when it is 1 foot from the ground, this convention is not retained, and it will not be retained when we come to practical examples of measurement of illumination. The two curves rapidly approach and cross at a distance equal to about 1.5 times the height of the lamp. (See pp. 36, 37.) After crossing they lie at a distance apart which is less than the thickness of the line in the diagram. When the screen is 4 feet from the ground, and the angle of incidence is 70° , the illumination is 0.0400 of the maximum. When the screen is dropped to 1 foot from the ground, the angle of incidence is $66^\circ 24'$, and the illumination is 0.0445. Although the slant height of the lamp is greater, the smaller angle of incidence more than compensates for it.

The difference seen on the left-hand side of the diagram loses its importance when the comparatively small area of horizontal surface over which this difference exists is taken into account. It may, therefore, be assumed when the lamp is more than 18 feet from the ground that the height of the photometer has very little effect on the mean illumination; the difference as regards minimum illumination is imperceptible, and the height need only be considered when measurements are being taken

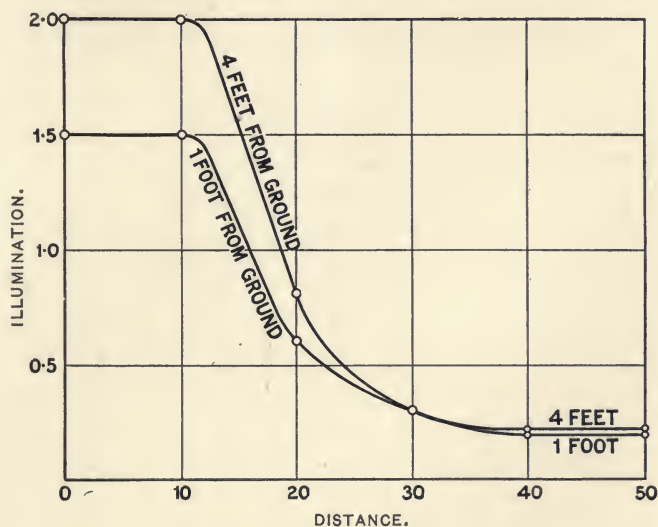

FIG. 155.

beneath a lamp. With street lamps only about 10 feet from the ground, the difference is very considerable.

When the candle-power of the lamp is not the same in all directions, measurements of illumination at various heights will be effected somewhat differently. Fig. 155 gives the results of two sets of measurements made by Roger T. Smith. In this case, owing to the distribution of light from the arc-lamp, the curves meet and then separate.

Direction of the Test-Plate.—Haydn Harrison, having used one of my earlier patterns, has modified it in several respects and has produced his own photometer. One of his chief modifications was the abandoning of the horizontal screen, and

the employment of one set at 45° in the instrument, but always used directly facing a lamp. He has recently added a horizontal screen which he finds necessary for certain purposes. This raises the question of the direction in which illumination should in general be measured, or to put it more explicitly, the position of the plane on which the illumination to be measured is received.

Wybauw of Brussels, one of the earliest writers on the distribution of illumination, contributed to the correspondence on my paper of 1892 to the Proceedings of the Institution of Civil Engineers.*

He criticised my treatment of the subject, and stated that :

It was not important in practice to know the illumination of any portion of a horizontal surface. The useful effect which a source of illumination could produce at the place under consideration should be ascertained. Particular data, such as horizontality of the surface, should, therefore, not be introduced into the calculations. It was desirable to assume any body whatever, having any kinds of faces—horizontal, vertical, or inclined—in the given position; better still, a spherical material point. . . . The useful effect of the illumination produced by a ray of light should be considered as quite independent of the bodies or surfaces upon which it fell. To deal exclusively with the useful effects produced upon the horizontal faces of bodies, and to neglect those upon the vertical or inclined faces, was to commit an obvious error. It was the sum of all those effects which constituted the real value of the illumination furnished by the source of light.

Against this view, the opinion of Herr L. Bloch † of Berlin may be quoted. Writing of calculations and of measurement of illumination, he says :

The figures in question must refer either to the horizontal intensity, *i.e.* the brightness on a horizontal plane in lux (metre-candles) or in the vertical light intensity, *i.e.* the brightness on a vertical plane in lux. If we regard it as the main purpose of street illumination to enable us to recognise objects on the ground, or to read a letter or a

* Vol. cx. p. 147.

† *Elekt. Zeit.*, May 24, 1906; and the *Illuminating Engineer of New York*, i. 580.

map of the city, etc., then the horizontal intensity is to be considered ; if, however, we wish to be able to distinguish, for instance, the faces of approaching people, the vertical intensity is to be taken into consideration. Both points of view are of equal weight ; hence other reasons must decide it. But the horizontal intensity has the decided advantage because it gives in all places on the ground only one simple value ; while vertical intensity may have several entirely different values for the same place, according to the direction in which the vertical plane faces. The face of a person may be very brightly illuminated if it is turned towards the next lantern ; but if that person should turn his back towards the lantern his face might no longer be distinguishable, although he still remains in the same place, since the other lanterns are comparatively far away from him. Hence the vertical intensity is not suitable for judging street illumination, as it gives no single value ; it is better to neglect it, since when the horizontal intensity is sufficiently great, there is also sufficient illumination with respect to vertical intensity.

The last sentence of this extract from Bloch's article expresses in other words my reply to Wybauw's criticisms. I referred to a diagram which has been produced as Fig. 17, and pointed out that the three curves, $\cos^2 \theta$ (for a plane always facing the light), $\cos^2 \theta \times \sin \theta$ (for a vertical plane), and $\cos^3 \theta$ (for a horizontal plane) ran fairly together, and that I had taken the lowest one.

I am glad to find that my views on the advantage of the horizontal position of the test-plate are endorsed by the recommendations of the *Verband deutscher Electrotechniker* on street photometry.*

Turning from the theoretical to the practical way of regarding this question, it is clearly possible for anybody who has a suitable instrument, to measure illumination with the screen set at any desired position. Roger T. Smith of the Great Western Railway, soon after providing himself with one of my illumination photometers, made some tests of illumination in Paddington Station with the screen set vertical. His results are shown in Fig. 156. The curve H represents the illumination received on a horizontal screen, N on a vertical screen,

* *Elec. tech. Zeit.* xii. 363 (1910); and *The Illuminating Engineer*, Lond., iii. 403.

facing north, S on a screen facing south, E and W on screens facing east and west.

There is very little difference between the mean of the illuminations on the vertical planes at the point midway between the two lamps, and the illumination of the horizontal plane at that point. At 20 feet from the East lamp the mean of the four vertical measurements is .575 foot-candle, while the horizontal illumination is .68. But the paradox is to be found

immediately below the lamp, where its own illumination on a vertical plane disappears, and the four measurements, having a mean of 0.27, are due to the light received from distant lamps. At this spot, the most brilliant illumination of all, namely, that due to the lamp overhead, is found on the horizontal plane. If these four sets of tests of vertical screens facing north, south, east, and west, are to be taken

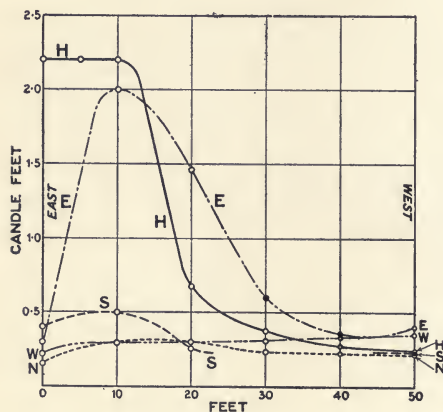

FIG. 156.

as measuring the illumination of this part of Paddington Station, what is to be done with them? Not even a dancing dervish can enjoy them all at once. It may be safely asserted that if the illumination received on a horizontal plane is good, the general illumination will be sufficient.

Two reasons seemed to have weighed with Haydn Harrison for inclining his screen at 45° , and using it, generally facing a lamp. One of these is the difficulty of measuring feeble illuminations with his instrument, and the other, that he really wishes to measure candle-power in the first place, and is content to calculate the illumination due to each lamp and to add these together.

The Use of Coloured Screens.—When the colour of the light received on the perforated screen differs from the colour of the small lamp which illuminates the movable screen, there is

some difficulty in making an approximate balance, and a considerable difficulty in making an accurate one. But the difficulty is not so great as at first sight appears. When the best possible balance has been made the colours are as apparent as ever, but the question is, Can the balance of brightness be improved? The handle should be turned quickly with decreasing range, and should then be stopped at about the middle position. With a little practice it is easy to reproduce the balance within 3 or 4 per cent. Some people find a greater difficulty with coloured lights than others, and those who are accustomed to fairly exact photometric work with lights of similar colour are among those who complain most of the uncertainty.

If the light to be measured is yellow, as that of most flame arc-lamps, one of a set of yellow movable screens may be used in the photometer, or the perforated screen may be bluish. The former has the effect of reducing the range of the instrument and the latter of increasing it. It is then easy to obtain a balance, but it only evades the difficulty during work, and it is necessary to find the coefficient applicable to each screen at leisure in the laboratory from the mean of a number of tests or by some other method unsuitable for outdoor work. It is possible to colour a pair of screens which counteract each other, but such a pair give a perfect match only for one kind of light. The makers have supplied such screens with my photometer, but they find that most workers prefer to use white screens. For the measurement of daylight a yellow perforated screen is necessary.

So far, the use of yellow screens has been suggested merely for the purpose of bringing the less yellow light to match the more yellow, but as was shown in the chapter on the photometry of coloured lights, page 174, such screens have another advantage and one based on another principle.

The range of an illumination photometer may be increased by tinting the perforated screen or test-plate with a neutral grey. Place the instrument so that it receives an illumination of 3 foot-candles. Take an artist's stump and some fine char-

coal powder, and lightly rub the screen. The slot will of course appear brighter. Turn the handle back to obtain a balance, and proceed cautiously shade by shade until the pointer indicates 1.5. The range is then doubled. If the screen is darkened until a balance is obtained at 0.6, the range is five times as great, and it may be pushed until the reading is 0.3, when the range is increased ten times. With such a screen no accurate work at feeble illumination can be done. For permanent use the tint should be imitated with Indian ink. In the case of a white screen it is easy to see if it has become soiled, but discoloration of a tinted screen can only be detected by test. When I was using the instrument illustrated in Fig. 136 I carried half a dozen screens of different tints and colours.

The Harrison Photometer.—As an expert, Haydn Harrison finds in street-lighting, that measurements of candle-power are generally of more importance for his purpose than measurements of illumination, and he is content to calculate the latter from the former, taking one lamp at a time. The original form of his photometer received the light only on a screen or test-plate set at an angle of 45° , but a horizontal screen has recently been added. The principle of a tilting inner screen is used, but the test-plate is not perforated. The comparison is effected by the use of the flicker principle. The instrument is illustrated in Figs. 157, 158, and 159. A rather small hole A, Fig. 158, in the top of the instruments allows the screen B to be seen when viewed vertically. The screen B is inclined at 45° , and consists of a disc from which two sectors of 90° have been cut away. The disc is free to revolve on a spindle, and is set spinning by a current of air acting on the vanes C, Fig. 159. The air is blown through the tube D by means of an indiarubber ball. A mirror E is set at such an angle that the tilting screen N may be seen through the hole A. The screen N may be illuminated by a small lamp F, or a large lamp G. When the disc B is set spinning, alternate views of the disc and of the screen N are seen, forming a flicker photometer. When the light to be measured is of about the same colour as that of the little lamp in the photometer, there is no advantage

over the use of a perforated screen or Conroy method, and there are some disadvantages. Some little knack is necessary to spin the disc at the right speed. At too high a speed considerable change may be made in the brilliances of the two screens without producing flicker. The knack may be learned in a few minutes, and little or no photometric experience is necessary. A rather important feature in connection with Haydn Harrison's work is the demonstration of the comparison of different kinds of illumination to the members of municipal governing bodies. Such a person would be able

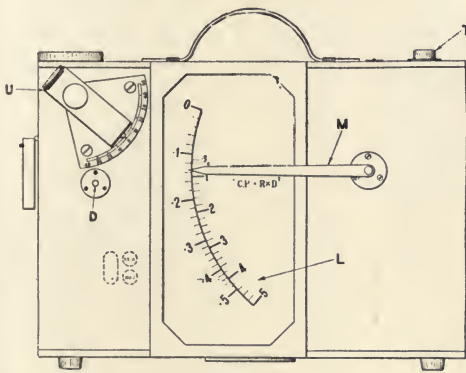

FIG. 157.—THE HARRISON PHOTOMETER, OUTSIDE VIEW.

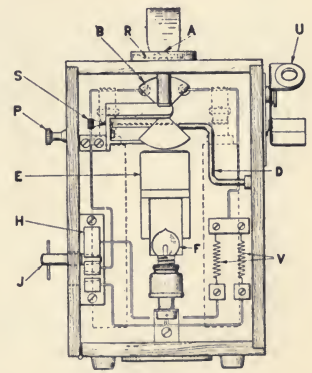

FIG. 158.—THE HARRISON PHOTOMETER, END VIEW OF INTERIOR.

to satisfy himself of the absence of flicker if the instrument had been set for him, and he would imagine that he was somewhat the wiser. But he might be troubled with the colour difference of an ordinary photometer with white screens.

For candle-power measurements in street work it is not necessary to deal with small illuminations, and these are avoided also by setting the disc at 45° instead of horizontally. The scale L of this photometer is not, therefore, intended for low readings. The pointer M serves also as a handle for moving the screen N. The knob P is provided for holding the end of a measuring tape. Either of the two lamps may be lighted by inserting the plug J into the two-way block H, thus securing one of the best kinds of contact. When not in use,

the plug is kept in the clip Q. The accumulator K is contained in the instrument, no loose wires are employed, and the connections between the lamps and the accumulator are permanent.

A level T is fixed on the top of the instrument, and for cases where the lamp to be measured is not directly facing the 45° screen B a clinometer U is provided. This consists of a lens which throws an image of the lamp on to a mark on a screen. Both lens and screen can turn on a horizontal axis, and an index shows the angle at which they point. Resistances V enable the lamps to be

adjusted for candle-power.

When a considerable number of lamps are in view it is not difficult, as a rule, to measure the combined illumination on a horizontal screen without obstructing any important lights; but the converse, the measurement of the candle-power of each, and the calculation of the combined

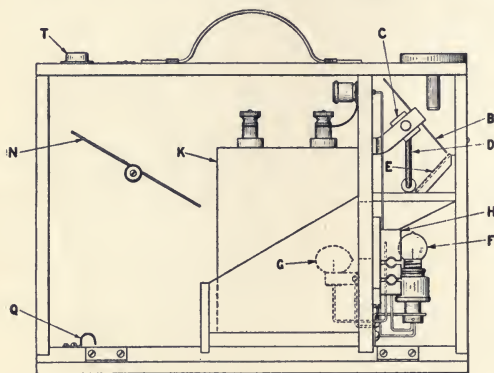

FIG. 159.—THE HARRISON PHOTOMETER, SIDE VIEW OF INTERIOR.

illumination would not only be very tedious, but would be inaccurate if, as in the case of interior illumination, there is much reflected light. For such purposes the screen inclined at 45° must be given up, and Harrison has provided a horizontal screen surrounding the hole A. When this is employed he abandons the use of the flicker principle, and the photometer becomes a perforated screen instrument, with a vertical view; the screen N being seen by reflection in the mirror E. The sector disc B is clamped by the screw S to give a clear view between the sectors.

The Weber Photometer.—This instrument was invented by Dr. Leonhard Weber, and described in 1883* as a portable photometer. At an early date it was used in conjunction with

* *Wied. Ann.* xx. 326; and Palaz, *Treatise on Photometry*, p. 85.

a white reflecting screen for measuring illumination, like the first Preece photometer.*

A horizontal tube, Fig. 160, carries a long slender benzine or amyl-acetate lamp at one end, and at the other, a transverse tube which can be inclined at any desired angle.

The transverse tube has an eye-piece at one end, and a disc of opal glass at the other. The eye-piece is provided with a reflecting prism for convenience in use when the transverse tube is pointed upwards. Another disc of opal glass is arranged to move in the horizontal tube. The two discs are viewed and compared by a Lummer-Brodhun double prism. A scale on the horizontal tube allows the position of the movable screen to be read on a uniformly divided scale.

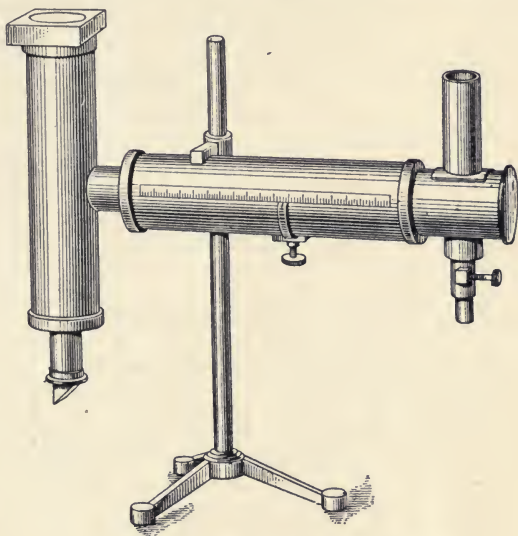

FIG. 160.—THE WEBER PHOTOMETER.

The Weber photometer arranged for measuring illumination is generally represented with a large white screen set at an angle with it, and a projecting hood or tube to prevent stray light from entering the instrument. This arrangement is shown by dotted lines in Fig. 161. The original use of this photometer with a white reflecting screen was probably due to a greater confidence in the application of the cosine law to the reflecting power of a matt white surface than in its application to a translucent screen of opal glass; but Millar has shown that when a disc of opal glass is ground on both sides it behaves fairly well, and this being the case, the instrument is suitable for use as an illumination photometer, and

* Fig. 134, p. 201.

offers the valuable feature of commanding an unrestricted view of the whole hemisphere.

The use of a benzine lamp as a sub-standard has been common in Germany; it must be allowed to burn for ten or fifteen minutes before any measurements are made, and the height of the flame must be adjusted with care. This lamp has been found very useful for indoor work, but for street

use the modern glow-lamp and battery are undoubtedly much better. It is clear that the range of the instrument is not great, and that for the higher readings, when the movable screen approaches the source of light, the law of the squares of the distance cannot be depended upon, especially if so large a source as a flame is used. The scale must therefore be calibrated by experiment. The instrument is imperfectly described

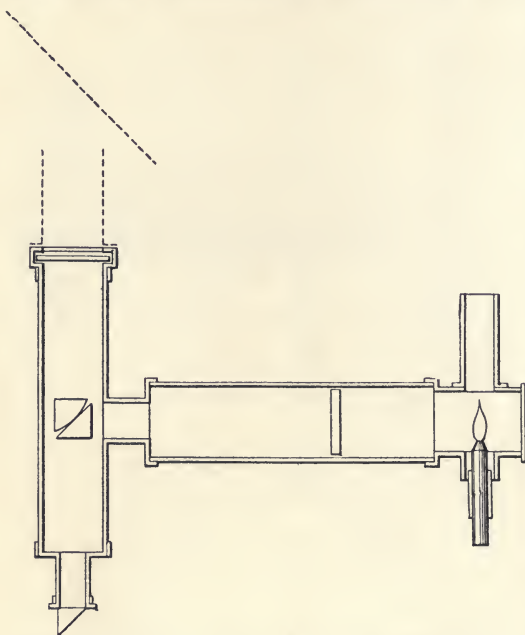

FIG. 161.—THE WEBER PHOTOMETER SECTION.

by Palaz, both in the original work and in the translation. Considerable attention is given to it by Stine.* The photometer of Mascart † resembles that of L. Weber in many respects. Good early work on the distribution of illumination was done also with this instrument. The photometer of Blondel and Broca ‡ is another instrument in which translucent screens are used. The light is controlled by an iris diaphragm.

* Stine, *Photometrical Measurements*, p. 78.

† Palaz, p. 65. Also P. S. Millar, *The Illuminating Engineer* of New York, ii. 481, and *Journal of Gas Lighting*, 1907, 632.

‡ Millar, *The Illuminating Engineer* of New York, ii. 479, and *Journal of Gas Lighting*, 1907, p. 634.

The Sharp and Millar Photometer.—After his critical examination* of all illumination photometers worthy of consideration, and a few others, Preston S. Millar has designed an instrument in collaboration with Clayton H. Sharp, and

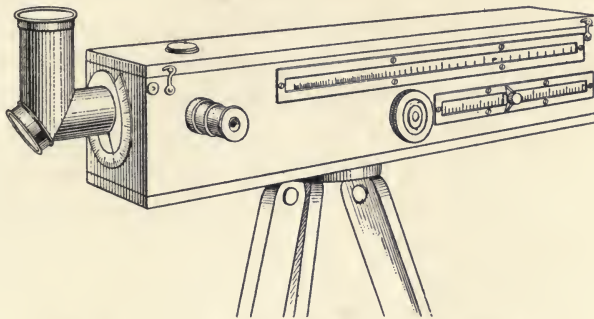

FIG. 162.—THE SHARP AND MILLAR PHOTOMETER.

his preparation for the work gives it special interest, for most inventors (with the exception of Haydn Harrison, who has used my photometer and developed a modification for his own special purposes) seem to have given but little attention to the work of others. This was not surprising, for until lately very little has been published on the subject. It is noteworthy that the Sharp and Millar illumination photometer † resembles that of L. Weber more than any other type.



FIG. 163.—THE SHARP AND MILLAR PHOTOMETER.

The instrument consists of a long box; the exterior is shown in Fig. 162 and the principal parts are illustrated in Fig. 163. It is much larger than most portable photometers.

* Millar, *Illum. Eng. Soc.* of Boston, 1907; *The Illuminating Engineer* of New York, ii. 475. See *The Illuminating Engineer* (London), ii. 727; and *Journal of Gas Lighting*, 1907, p. 630.

† See *The Electrician*, lx. 562, Jan. 24, 1908.

An elbow tube, which, like the transverse tube of the Weber instrument, can be turned and clamped in any direction, is attached to one end of the box. A disc of opal glass, ground on each surface, covers the end of the tube. At the elbow a mirror is fixed. A partition in the box carries another opal screen. This is illuminated by an electric lamp which may be moved by cords and a large handle. The two screens are compared by a Lummer-Brodhun double prism. The principle is therefore identical with that of L. Weber, except that the internal opal screen is fixed, and the lamp is movable. A translucent celluloid scale allows the shadow of an index to be clearly visible. In order to avoid errors due to reflected light, a number of light diaphragms (not shown in the illustration) are used. The range would be small were it not that two neutral grey glass screens are provided. One of these transmits about 10 and the other about 1 per cent of the light. Since either or both screens may be interposed between the interior opal screen and the double prism, or between that prism and the test-plate, the range is largely extended. An adjustable resistance allows the candle-power of the electric lamp to be adjusted so that the scale becomes direct reading.

One of the most important points in such an instrument is the behaviour of the test-plate for light falling on it at different angles. The reason why Millar has used a translucent screen instead of matt white reflector is to enable him to command an unobstructed view of the whole hemisphere facing the test-plate, and he achieves this by viewing it from beneath. He has mistrusted the application of the cosine law to matt white reflectors, but it is doubtful whether his test-plate presents any advantage in this respect over a good opaque screen. Since the diagram in *The Electrician* giving the departures from the cosine law does not appear to do justice to the screen, I have asked Mr. Millar for the actual results of tests. He has been good enough to send me a specimen test-plate, and a curve which is reproduced in Fig. 164. From this I have constructed Fig. 165 for the purpose of comparison with Figs. 147, 148, and 149. Mr. Millar's

method of plotting Fig. 164 which gives the error per cent at different angles is the better way of showing the errors at large angles of incidence.

This photometer is well adapted for ordinary candle-power measurement, since the elbow tube can be turned in any direction. The inventors claim that the variable distance method has the great advantage that its indications depend upon a known law, and that consequently a scale can be made from calculation and not as a result of various trials.

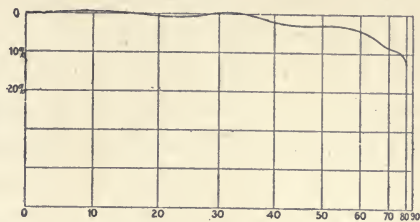

FIG. 164.—SHARP AND MILLAR TEST-PLATE ANGLE ERRORS.

Notwithstanding the simplicity of the law of inverse squares, it seems likely that at high illuminations some allowance must be made for error due to the size of the lamp. At the extreme right-hand end of the scale the distance of the lamp from the opal screen appears to be about twice the length of the filament of the lamp. The right-hand end of the scale is very contracted; a small movement of the lamp makes a large difference in the illumination, and unless a plain horse-shoe filament is used, the theoretical position of the lamp must be difficult to settle. It is doubtful whether any portable photometer has ever been constructed which may be relied upon to act according to a theoretical principle. Where an accuracy of ordinary working of 3 or 4 per cent is intended, the scale should be accurate to at least $1\frac{1}{2}$ per cent.

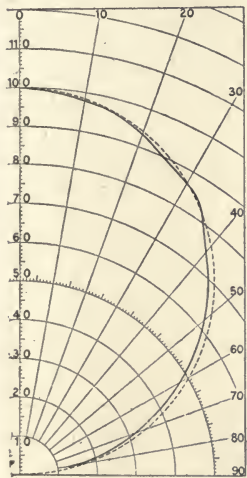

FIG. 165.—SHARP AND MILLAR TEST-PLATE ANGLE ERRORS.

The Wingen-Krüß Photometer.—The illumination photometers which have been described have horizontal screens or test-plates receiving light from every direction with no obstruction except that of the observer's body. For the general illumination of interiors it is necessary that the

test-plate should command a wide view. Several instruments have been designed for measuring the illumination on desks, which receive light principally from windows in one direction. An instrument of this kind was designed by A. Wingen, and has been made by Krüss of Hamburg. It consists of a box containing a benzine lamp which illuminates a white screen in the box, and this is compared with another screen just outside the

box. The illumination is balanced by altering the height of the flame of the benzine lamp, and this height is measured on a scale. This primitive and crude arrangement has been replaced by the adoption of my movable screen and cam. The arrangement is shown in Fig. 166. The height of the flame of the benzine lamp is adjusted to a gauge line. The eye-piece, inevitable in German instruments, gives a view of the test-plate M, which

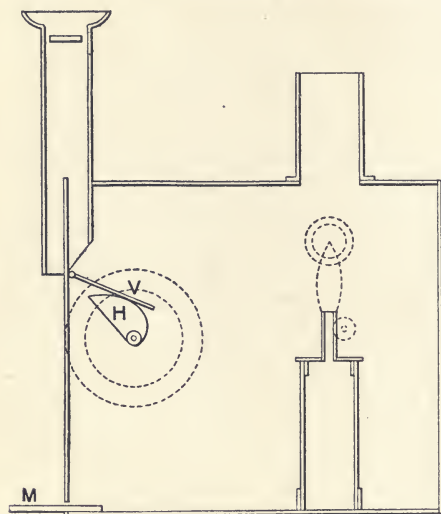

FIG. 166.—THE WINGEN-KRÜSS PHOTOMETER.

receives the illumination to be measured, and of the inner movable screen V. This rests on a cam H, of such a shape that approximately uniform angular movements of the shaft on which it is fixed give uniform alterations of the illumination of the movable screen. The range is from 10 to 50 *Meterkerzen*, or from 0.93 to 4.65 foot-candles. Tinted glass screens sliding in the eye-piece are used to increase this range.*

The Martens Photometer.—This is another instrument employing a benzine lamp, and having a test-plate of plaster of Paris intended to receive light mainly from above or in one side direction, other directions being obstructed by the instrument as in the Wingen Photometer. Fig. 167 is a diagrammatic view of the arrangement which cannot be shown in simple plan,

* Fully described in *Journal für Gasbeleuchtung*, 902, p. 738, and *Journal of Gas Lighting*.

as the parts are arranged at various angles, and an end view, showing only the essential features. The benzine lamp *L* is fixed, and its light is reflected by a pair of mirrors *M* on to a prism, which reflects it on to a ground-glass screen *G*. On looking through the eye-piece, the image of this screen is seen alongside an image of the white screen *S*. The most original part of this apparatus is the use of the pair of mirrors for altering the illumination. Even with the double effective length of travel which these provide, tinted screens must be used to give a useful range.

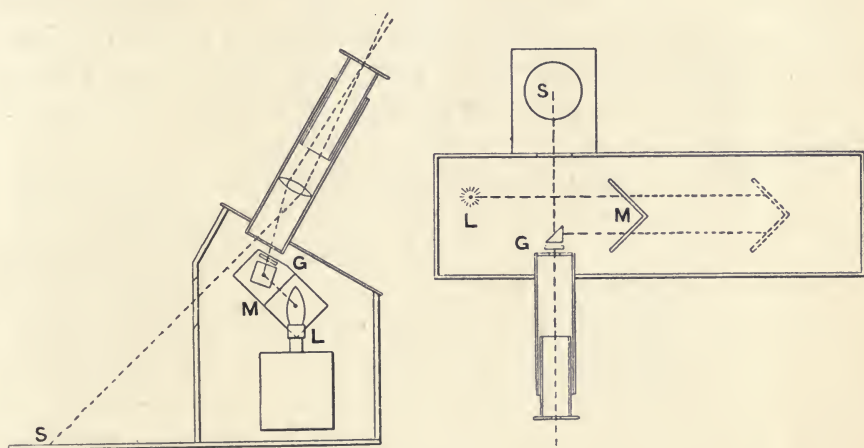

FIG. 167.—THE MARTENS PHOTOMETER. DIAGRAMMATIC PLAN, END VIEW.

Iris Diaphragm Photometers.—A photometer was made some twenty-five years ago by Petruschewsky for measuring the illumination on school desks. The light from an oil lamp was cut off by a diaphragm having a tapering aperture. Blondel and Broca have used a “cat’s-eye” diaphragm. My unsuccessful attempt to use this device has been mentioned, but I applied it simply to a small glow-lamp, and when the light was cut down for measuring feeble illumination, the diaphragm acted as a pinhole, and gave an image of the filament. Blondel and Broca place an opal glass screen between the lamp and the diaphragm and avoid that difficulty.

This principle has been used in the Simmance-Abady

photometer, with the intention of employing a simple law and avoiding experimentally graduated scales. A small electric glow-lamp is employed, but this is not used directly. It illuminates the interior of a small globe whitened inside. The light diffusively reflected from one side of this globe illuminates a flicker photometer, and the area of the surface exposed to the photometer is controlled by an iris diaphragm. This claims to be a direct-reading instrument. The use of the flicker photometer renders the apparatus unsuitable for low illuminations, and like the Harrison instrument it is intended mainly for candle-power photometry. When used for illumination a reflecting screen is used somewhat in the same position as that of the Martens photometer. The Simmance-Abady photometer with its accessory apparatus is carried about on a wheeled carriage.

Brightness Photometers.—The illumination photometers which have been described are provided with test-plates of the whitest possible material, and the brightness of the test-plate is taken to be a measure of the illumination received by it. Another class of instrument having no test-plate, may be used for examining and measuring the brightness of any surface such as the walls of a room or the ceiling, the backs of books on a library shelf, or an object in a shop window. The quantity measured is the brightness or the product of the illumination into the albedo, assuming the albedo of some such standard substance as white cardboard to be unity. While this book was being completed three such instruments made their appearance, and though they are not suitable for very feeble illumination, they seem likely to be more convenient than illumination photometers for certain purposes. For example, the Trezise instrument was designed for measuring the lighting of telephone switchboards. Strictly speaking they do not measure light, but surface brightness (*Flächenhelligkeit*). Names constructed from the Greek words for brightness, such as lampro-meter, phainometer, aiglometer, do not commend themselves, and mongrel names have been given instead.

The Dow and Mackinney Lumeter.—An instrument so

portable that it can be carried in the pocket, belongs to that type of illumination photometer of which the test-plate is exterior to the apparatus. A lamp A, Fig. 168, illuminates a white perforated screen B by light diffused from a screen of ground opal glass C. The surface to be examined is observed through the eye-piece D, through the perforation in the screen B, and through a hole in the case at E, grey screens being

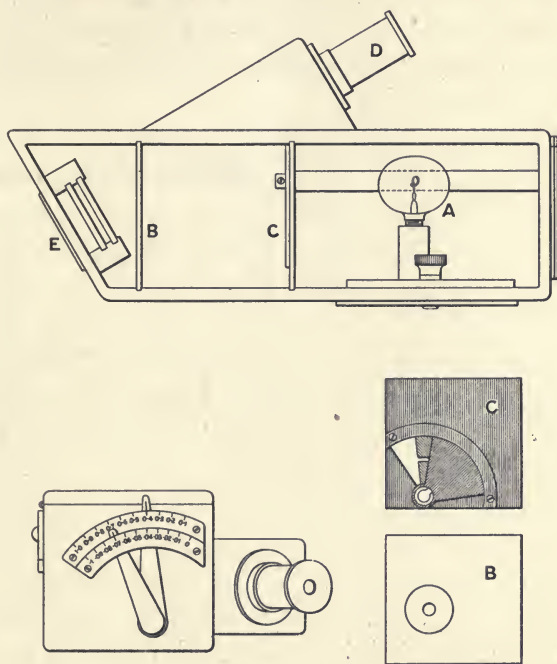

FIG. 168.—DOW AND MACKINNEY'S LUMETER.

interposed if necessary. The illumination of the screen B is controlled by opening or closing shutters which reduce the effective area of the screen C. These are adjusted by levers moving over graduated scales. The part of the case containing the lamp is painted white to assist the illumination, which suffers considerably through absorption of the screen C.

The Everett-Edgcumbe Luxometer.—Edgcumbe has, as it were, turned my illumination photometer inside out in the construction of another pocket instrument for measuring bright-

ness. A movable screen A (Fig. 169) illuminated by a lamp L controlled by a cam (see Fig. 141) is seen by reflection from the mirror B in the silvered part of a mirror C, and the surface to be examined is viewed through a part of the mirror from which the silvering has been removed. The instrument may be used (1) for the measurement of illumination by placing the screen D at the required angle; (2) for the measurement of candle-power by placing the screen D normally to the rays; (3) for the measurement of brightness by removing the screen D and viewing the object itself. The Luxometer is usually scaled up to 20 foot-candles.

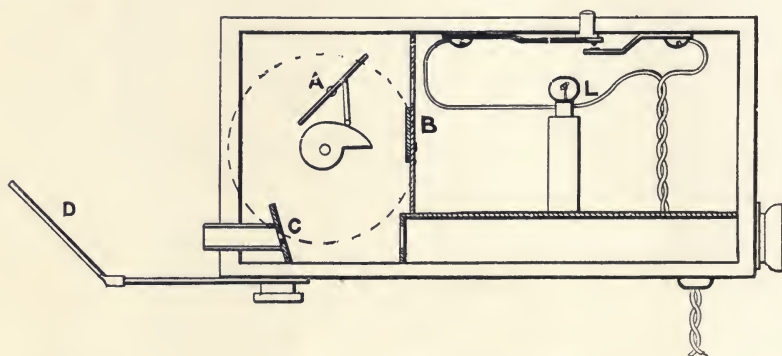

FIG. 169.—EVERETT-EDGCUMBE LUXOMETER.

The Trezise Photometer.—While these pages were passing through the press, J. M. G. Trezise was perfecting a photometer for measuring brightness. A lamp and an opal glass disc are used as in the Weber, Blondel and Broca, and Dow instruments, but both the disc and the lamp are capable of being moved with reference to a perforated screen. The lamp is a very small one, and can be placed close to the opal screen, thus illuminating it brightly. The twofold adjustment gives a large range.

Photometry of the Daylight Illumination of the Interior of Buildings.—The illumination of a room by ordinary daylight depends on three conditions. First, the external character of the source of illumination, viz.—the time of day, the time of year, the kind of weather or sky; second, the area and aspect

of the windows; and third, the colour or reflecting power of the walls, ceiling, floor, and contents of the room. The first of these conditions is so variable that it must be eliminated. The second and third being practically constant for any room, may be measured together and expressed as a coefficient.

I have succeeded in eliminating the first of these conditions by adopting as a unit, of which this coefficient is a fraction, the illumination which would be produced at the spot in question, if all buildings in the neighbourhood were demolished, and the illumination were produced by light from a uniformly grey sky.

The source of daylight is of four kinds. First, but not most frequent in London and other cities, direct sunlight; second, sunlight reflected from more or less blue sky; third, sunlight reflected from white or grey clouds; and fourth, light transmitted through clouds. On a considerable number of days in the year, the sky of London, and to a less degree, in other parts of England, is of a more or less uniform grey. For the purpose in question the illumination derived from parts of the sky near the horizon does not concern us, and it may be assumed for the present purpose that the sky is of a uniform brightness on a "grey day." If there were no buildings or other obstructions, the source of light would then be a hemisphere. The solid angle of a hemisphere being 2π , it will suffice to take the illumination produced by a small definite portion, say $1/1000$ th of this. A portion near the zenith will be most convenient. The measurement may be made by any illumination photometer, and as the result is to be a coefficient, no standard of illumination or candle-power is required, but only a lamp which can be depended upon for steadiness during the test.

Suppose that a hemispherical cover of 10 inches radius, and having therefore 628 square inches surface, is placed over the photometer screen, and a round hole 0.89 inch diameter, that is, 0.628 square inch area, is made in this cover. The amount of illumination falling on the photometer screen bears the same proportion to the total illumination which would fall on the

uncovered screen, as the area of the hole in the cover bears to the total surface of the hemisphere; in this example, one-thousandth.

Instead of a hemispherical cover, a blackened tube, Fig. 170, 10 inches long, is used. Suitable stops are placed at the top, and a side tube like the spout of a coffee-pot allows the screen to be seen. The stops may vary from $1/2000$ th, having a diameter of 2 inches, to $1/5000$ th with a diameter 0.4 inch. To measure the daylight coefficient of a room or hall or railway station, on a grey day, use a yellow screen or test-plate, fit the tube over it, and take the instrument out of doors or place it outside a window, so that it has a clear view of the sky overhead. Obtain a balance, choosing such a stop as will give a reading at a convenient part of the scale. Take the instrument indoors, remove the tube, and measure the illumination in the ordinary way. After making a few measurements, take it out of doors again and check the outdoor reading. If the outdoor reading be, say, 0.7 foot-candle with a $1/1000$ th stop, and the reading indoors be 0.5 foot-candle, then the coefficient

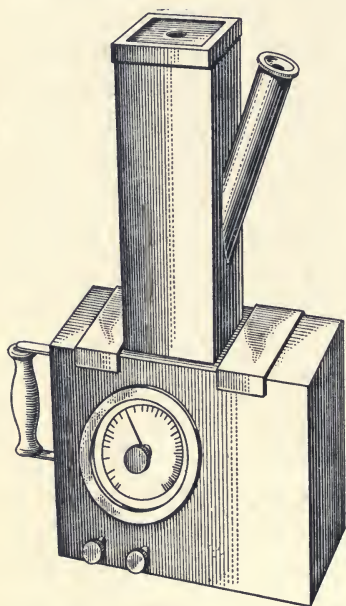

FIG. 170.—TROTTER PHOTOMETER WITH DAYLIGHT ATTACHMENT.

for the room is $\frac{0.5}{0.7} \times \frac{1}{1000}$ or 0.00071.

As a matter of fact the sky at the zenith is generally a little brighter than the average of a grey sky, but it would be tedious to make a number of measurements at different angles and take the mean, and a view of the sky at different angles cannot always be obtained. The simple zenith measurement gives a good and perfectly definite basis for comparison, even if it be arbitrary.

When I first devised this system of measurement of daylight illumination in 1895, I suggested that it would be useful to know

the coefficients of various well-known buildings. I made a few experiments, but no practical work was done until P. J. Waldram took it up twelve years later. He has made much practical use of this method and has published the following results : *—

British Museum, Reading-room	0.007
” ” Entrance Hall	0.0017
Patent Office Library, centre of Reading-room	0.005
” ” ” reading alcoves and galleries	0.0007 to 0.008
Royal Courts of Justice—Middle of Central Hall	0.0012
” ” ” Courts—Judges’ seats	} . 0.0007 to 0.0022
” ” ” Counsel	
” ” ” Solicitors	
” ” ” Jury and Witnesses	
House of Commons, Clerk’s table	0.0008
Speaker’s Chair	0.0009
Behind do.	0.0002
Members’ seats	0.0003 to 0.0007
House of Lords, Woolsack	0.0006
Members’ seats	0.0004 to 0.0006
Commons Lobby	0.001
Lords’ Lobby	0.0004
Central Hall	0.0015
Committee Rooms (Centre)	0.004 to 0.005
Westminster Hall (Centre)	0.0012
Charing Cross Station, Booking Hall	0.0001 to 0.0003

To match the colour of daylight, the light of a lamp may be passed through blue glass, the exact hue depending on the kind of lamp employed.† Or daylight may be passed through a screen stained with methyl-orange, to match the colour of the lamp. The colour of daylight varies considerably.

* *Journal of Soc. of Architects*, Jan. 13, 1910; *Ill. Eng.*, London, i. 811.

† See “Notes on the Light of the Electric Arc,” *Journ. Inst. Elec. Eng.* vol. xxi.

CHAPTER XI

PRACTICAL EXAMPLES OF MEASUREMENTS OF ILLUMINATION

Wimbledon, 1884.—The only records which I have of measurements of illumination made with Sir W. Preece in the “eighties” are a few of the experimental lighting at Wimbledon.* Fig. 171 is probably one of the earliest illumination curves plotted from actual measurements. These were taken on May 21st, 1884. Two Swan lamps on posts 20 feet (6 m.) high

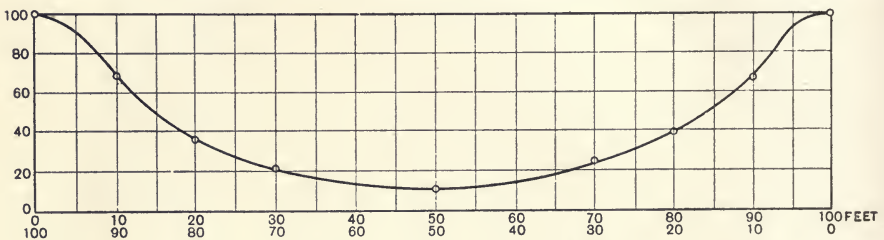

FIG. 171.—CURVE OF STREET ILLUMINATION (1884).

were set 100 feet (30.5 m.) apart. The measurements were calculated in foot-candles or metre-candles, but are plotted with 100 as an arbitrary maximum.

London, 1891-2.—The two principal objects of the work which I carried out in London in the winter of 1891-2 were to ascertain the nature of the distribution of illumination in various streets and public places, and the amount of that illumination in foot-candles.

The observed distribution of illumination was found to agree very closely with the general results which might have

* Report of Mr. W. H. Preece to the Streets Committee of the Honourable the Commissioners of Sewers of the City of London, 1885. See also *The Electrician*, vol. xiv. p. 498.

been arrived at by calculation. This agreement was satisfactory since it afforded a practical confirmation of the theory. Iso-lux curves or contours of equal illuminations based on calculations such as those of M. Marechal* are interesting exercises, and make attractive diagrams, but they do not carry much weight with the consulting engineer, borough surveyor, or lighting contractor. On the other hand, three or four dozen good measurements of illumination plotted graphically either as illumination curves or as contours, do not carry full conviction unless it can be recognized that they represent results which can be analysed by simple calculation. If the engineer who has to specify for or to carry out the illumination of a street or building, examines a few cases of measurements of illumination, or better still if he makes a few tests with an illumination photometer and compares them with the theoretical distribution (just as a civil engineer might study the construction of different types of bridges and compare them with the theory of their design) he will be able to judge intelligently of the two chief factors of practical illumination; first the degree of uniformity which is suitable for a particular case, and how that may be obtained by the best distance between the lamps and their best height from the ground; and second, the candle-power necessary to give the illumination desired.

In 1892 I did not attempt to deduce any definite rules from the results of my measurements, but I stated that 0.03 foot-candle appeared to be the lowest point that should be reached in a well-lighted street. In the eighteen years which have elapsed since those measurements were made, the minimum illumination of streets and average speed of the traffic, and perhaps the noise, have increased about three-fold.

South Kensington Museum.—I have had some hesitation in rewriting that part of my paper of 1892 which dealt with the result of measurements, but I offer them to my readers partly because they were the first set of extensive measurements of illumination, and partly for the purpose of comparison with the improved lighting of the present day. One of the first examples

* *L'Éclairage à Paris.*

which I examined was that of South Kensington Museum. The Sculpture Court, containing the Trajan Column, was well and sufficiently lighted by Brush arc-lamps placed at the very considerable height of about 50 feet (15.2 m.). This court, which still remains with but little alteration, is 135 feet by 60 feet, the height of the ceiling is 83 feet. The illumination was quite sufficient for the students, who are to be found there in the evening, sketching architectural and other details. The great size of many of the objects exhibited in this court prevented more than seven or eight lamps being seen from any one position. It was found that the illumination 6 inches from the ground depended at any point simply on the number of arc-lamps in sight at that point. The following readings were taken near the end of 1891 with the 6-inch cube photometer : *—

Foot-candles	0.55	0.5	0.6	0.5	0.8	0.7
Number of arcs in sight	6	6	7	6	8	7

In the Silversmith's Court the illumination was found to be 2.6 foot-candles with ten arc-lamps in sight. In the Japanese Court 1.6 foot-candle with eight lamps in sight; in the Great Hall near the centre, 2.4 foot-candles with nine arc-lamps in sight, the lamps being about 25 feet from the floor. In the gallery over the Silversmith's Court, near the bookbinding cases, about 3.5 foot-candles were recorded. Opposite the refreshment room, in the corridor lighted by glow-lamps, the illumination was found to be 0.65 foot-candle.

In the report on the action of light on water-colours † by Dr. Russell and Captain Abney, measurements made by General Festing with the Preece Photometer are given. North-east water-colour gallery (gas), 1.81 foot-candle; south-east water-colour gallery (gas), 2.32 foot-candles; Jones Bequest gallery (electric glow-lamps), 1.72 foot-candle; Raphael gallery (arc), 2.26 foot-candles; Sheepshanks gallery (arc), 3.12 foot-candles. The mean natural illumination of daylight measured for the blue rays in one of the galleries during April and May

* Pp. 103 and 203.

† *Blue Book*, C. 5453, 1888.

was about 13 foot-candles. On thirteen days it exceeded 20 foot-candles, the maximum was about 36.

Charing Cross and Cannon Street Stations.—By permission of Sir Myles Fenton, measurements were made at Charing Cross and Cannon Street Stations. The arc-lamps at Charing Cross were about 18 feet (5.5 m.) from the platform. The maximum illumination on the evening of 29th January 1892, was to be found between 15 and 22 feet from the point below the lamp, and varied from 0.4 to 0.5 foot-candle. The minimum was about 0.05 foot-candle. There were fourteen arc-lamps in the station, arranged somewhat irregularly in four rows. The

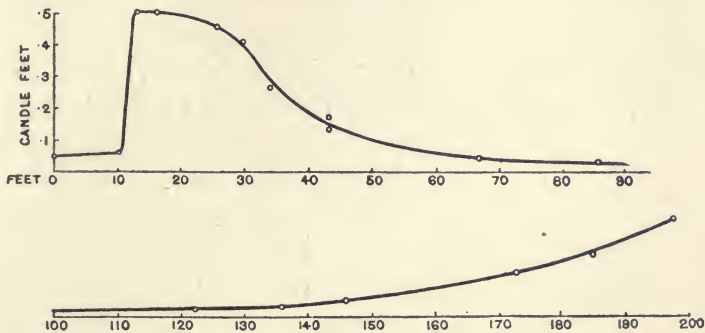

FIG. 172.—DISTRIBUTION OF ILLUMINATION AT CANNON STREET STATION (1872).

station covers about 9050 square yards (7550 sq. m.). There were, therefore, roughly, 646 square yards (540 sq. m.) to each lamp.

Two sets of measurements were made at Cannon Street Station, one with the 6-inch cube photometer, and another, on the date already mentioned, with the improved form. These measurements agreed fairly well with each other; the first pattern gave low readings for low illuminations, owing to diffused light on the reflecting screen.

Fig. 172 shows the distribution of illumination along the main-line arrival platform, starting from the point beneath a lamp enclosed in a lantern of clear glass. There was a deep shadow of 0.05 to 0.06 foot-candle beneath the lamp. All the readings are given as small circles on the curve. The lamps

were an old form of the Brockie pattern, and took 15 amperes; they were hung at about 35 feet (10.6 m.) from the platform. There were eight lamps, arranged symmetrically. The station covers about 13,900 square yards (11,600 sq. m.), giving about 1740 square yards (1450 sq. m.) to each lamp. The minimum was about 0.025, and maximum 0.35 to 0.5 foot-candle, distinctly less than at Charing Cross; but the greater height of the lamps prevented the glare which was to be found at the latter station. Assuming the volts of the lamps to be about the same, the watts expended at Charing Cross were about 15 per cent greater than at Cannon Street. The difference in illumination was greater than this; but, owing to the irregular arrangement of the lamps at Charing Cross, an exact comparison could not be effected unless a complete survey of the station had been made. On 6th May 1910, the maximum illumination on the arrival platform at Cannon Street was 1.65 foot-candle, and the minimum was 0.08.

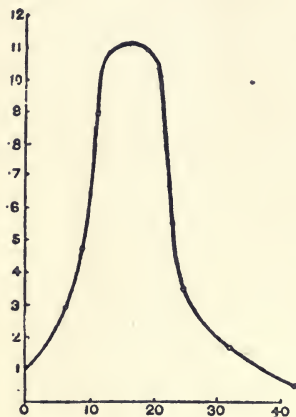

FIG. 173.—MAXIMUM I. I
FOOT-CANDLE.

City of London.—The street lighting in the City was measured by me on several occasions. A very large number of repeated observations would be necessary to give an exact result, since there was a considerable variation of light when the arc-lamps “fed.” The three curves Figs. 173, 174, 175 were picked from a number, as the best performances of the lamps. In these curves all the readings in any one set of observations are recorded; none have been suppressed as doubtful. The curves are drawn to

represent the probable distribution of illumination as nearly as possible. The horizontal distances are given in feet, and the scale of foot-candles has no relation to the height of the lamp, as in Chapter III. In several of the highest cases it was noticed that the light was not thrown uniformly, owing to the formation of the crater on one side, perhaps on account of bad setting of the carbons.

Fig. 176 gives the illumination curve of a lamp in Cornhill, measured along the diagonal line of the direction of another lamp. A considerable crowd had collected when seven readings had been taken, work had to be stopped, and it is assumed that

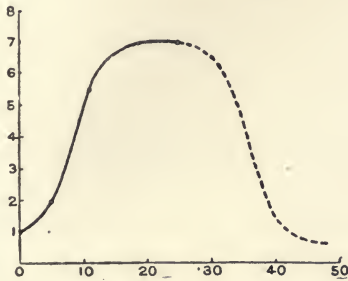

FIG. 174.—MAXIMUM 0.7 FOOT-CANDLE.

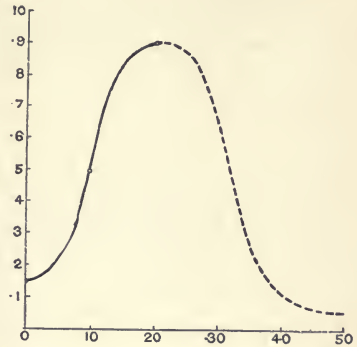

FIG. 175.—MAXIMUM 0.9 FOOT-CANDLE.

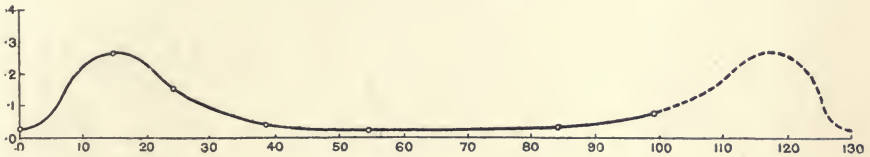

FIG. 176.

the remainder of the curve would be symmetrical, as shown. Fig. 177 is Fig. 173 on another scale. The maximum light being given at about 45° , and $\cos^4 45^\circ$ being 0.25, the value of the illumination at the maximum is to be found on the scale of foot-candles, at a height equal to 0.25 of the height of the lamp, this height being measured in feet on the same scale as that of the horizontal distance.

On a visit on 6th May 1910, with the object of repeating some of these measurements, I

found that gas had replaced electric light in Queen Victoria Street. On the position occupied by the lamp represented in Fig. 174, a double mantle gas lamp gave a maximum of 0.34 foot-candle, less than half of the illumination on the same spot eighteen years before.

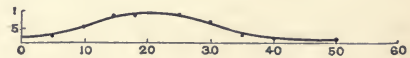

FIG. 177.

In the course of a very careful measurement of the lighting in Queen Victoria Street, on the 29th of January 1892, it happened that the light of the three lamps was, during the

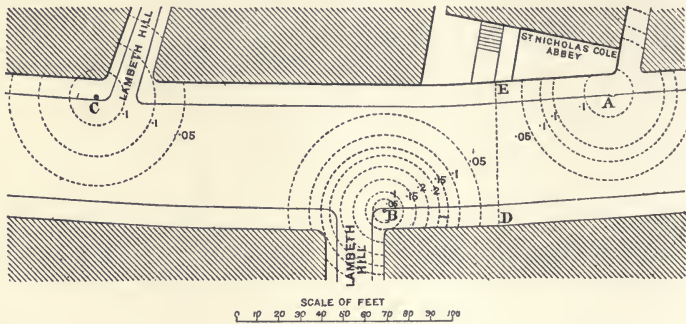

FIG. 178.

greater part of the test, below the average. A plan of the portion of the street, corrected from the ordnance map, is given in Fig. 178. The three lamps are marked A, B, C, and a line across the street at the minimum is marked DE. The illumination curves in Figs. 179 and 180 show the actual readings. Starting from A, the illumination was 0.1 foot-candle at the foot of the lamp-post. A few seconds later, at a distance of 11 feet (3.350 m.), before another reading could be taken, the lamp fed,

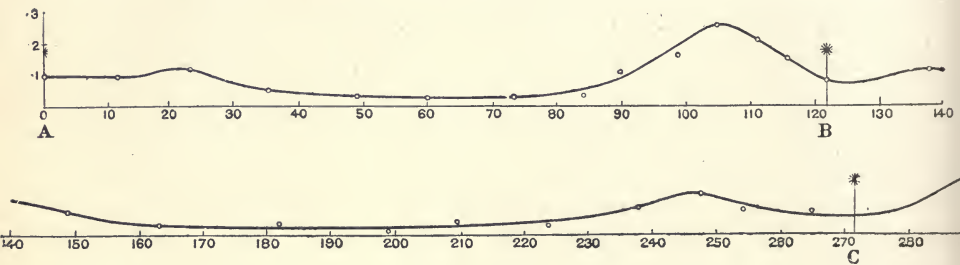

FIG. 179.

and the reading at this point was the same. The measurements were continued without interruption, and the early ones probably represent the lowest illumination that was to be found under these circumstances. On approaching B the light was good, and was a fair average of what I had found in some

dozen or more tests. On starting towards C, lamp B fed, and C appears to have been below the average of this series of measurements. The measurements of distance were made with a tape; the assistance of the police constables, kindly provided by Inspector Fraser, greatly facilitated the work, by diverting the traffic and by keeping off bystanders.

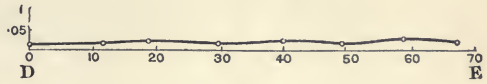

FIG. 180.

The contour lines are practically circles. It has been assumed, in the circles drawn in Fig. 178, that lamp C was burning well. If the contour of 0.04 foot-candle had been drawn, it would probably have been of the hour-glass kind,* just looping on to the pavement near the minimum. The arc-lamps appeared to be about 17 feet 8 inches (5.33 m.) high, and the distance of the lamps apart was about 6.5 times their height. These have now been replaced by gas lamps.

On 6th May 1910, the illumination at the point E, Fig. 178, by gas lamps, was 0.012 foot-candle, and the maximum near the lamp at A was 0.38.

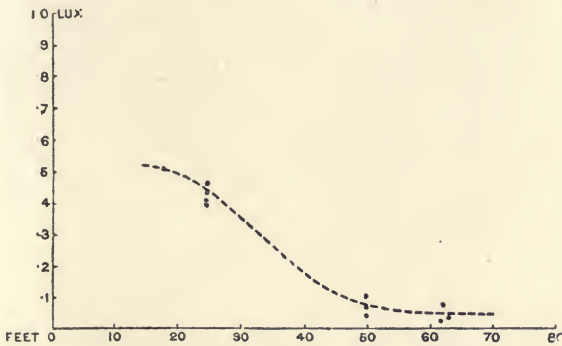

FIG. 181.

A number of measurements, made under the direction of Sir W. H. Preece, with his photometer, on different dates, and in different parts of Queen Victoria Street, are represented in Fig. 181,

and an attempt has been made to draw a curve among them. The ordinates are given as decimals of a metre-hefner.

Whitehall.—On 11th February 1892, a careful survey of Whitehall was made. Fig. 182 is a plan of the part of the street between Downing Street and Whitehall Gardens. The

* P. 48.

gas lamps are marked A to N, both on the plan and on Figs. 183, 184, 185, and 186, which give the illumination curves along the measured lines. Only a single reading near the

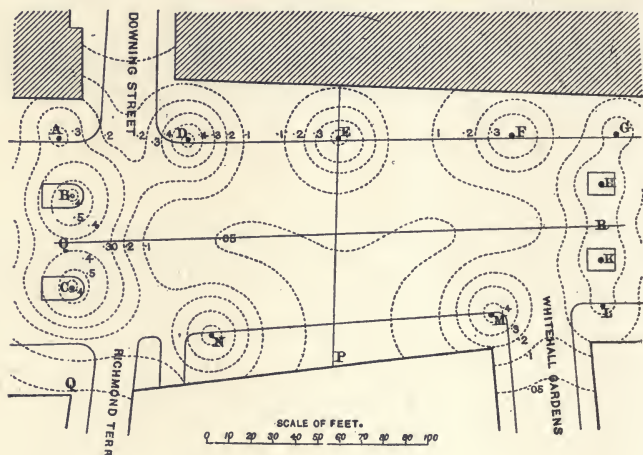

FIG. 182.—CONTOURS IN WHITEHALL.

minimum has been suppressed, being obviously wrong. I was informed by Messrs. Sugg & Co. that the lamps were of the following description:—The small side lamps were “Whitehall” pattern, and were of 90 candle-power, consuming 20 cubic feet per hour. The large lamps were of the “Westminster” pattern, of 270 candle-power, consuming 50 cubic feet per hour.

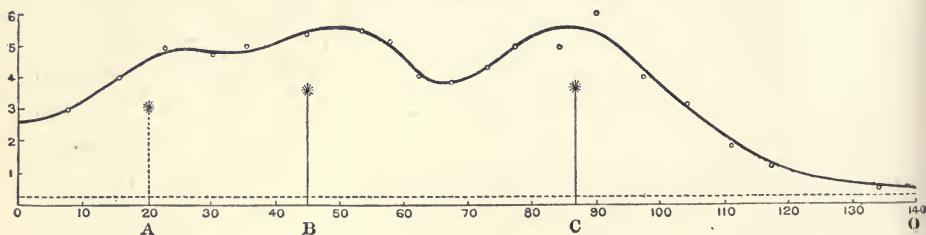

FIG. 183.

The illumination curves show very clearly the effect of the shadow below the ordinary lamps. The large lamps at the “refuges” were provided with reflectors, which greatly lessened the shadow. Either because the transverse line AQ was not taken immediately below the lamps B and C, or by some error

in the measurements, the shadow below these lamps does not appear plainly. From these illumination-curves may be seen

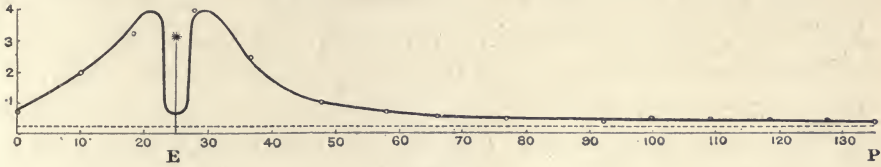

FIG. 184.

the gradual rise of the minimum between A and D and between F and G, owing to the effect of the lamps at the refuges. The

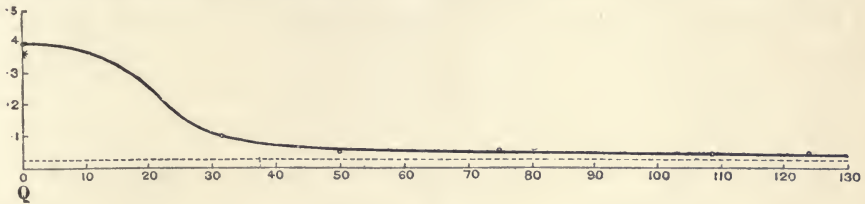

FIG. 185.

moon was nearly full, and the sky was cloudless.* The dotted line represents the illumination, 0.025, due to moonlight. The

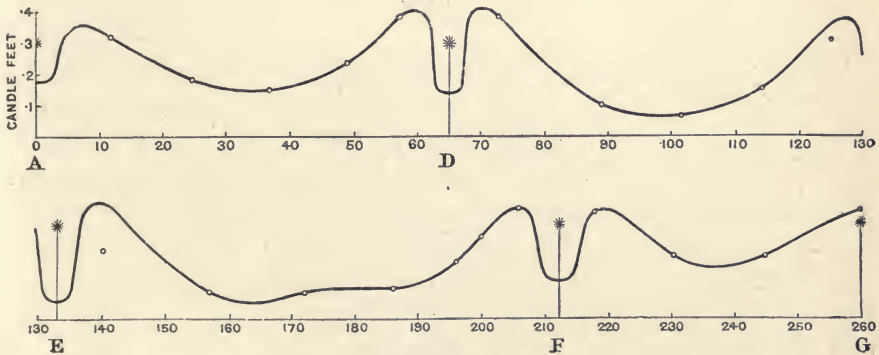

FIG. 186.

survey was completed at about 11 P.M. From these curves the contour-lines in Fig. 182 were drawn, and from these contour-

* Several attempts were made to measure street illumination on moonlight nights when clouds were drifting over the sky. Although the photometer was screened from the moon, the measurements were very irregular. Street measurements in a town in South Wales had to be stopped until the reflection of the blast furnaces in the sky was over.

lines I constructed a model on the scale of 20 feet to an inch in plan, and 1 foot-candle to an inch in elevation.

Fig. 187 gives some measurements which I made on 22nd April 1910, between the points E and G, Fig. 182. The lamps had been rearranged. The upper curve was taken with the photometer some 4 feet (1.22 m.) from the ground, the lower with the screen $7\frac{1}{2}$ inches (190 mm.) from the ground. The maximum illumination was about twice the maximum in 1892.

The difference between the illumination in Queen Victoria Street and in Whitehall was so very much less than I expected that I repeated the measurements of the maxima and minima at Whitehall on February 25, and proceeded at once to Queen

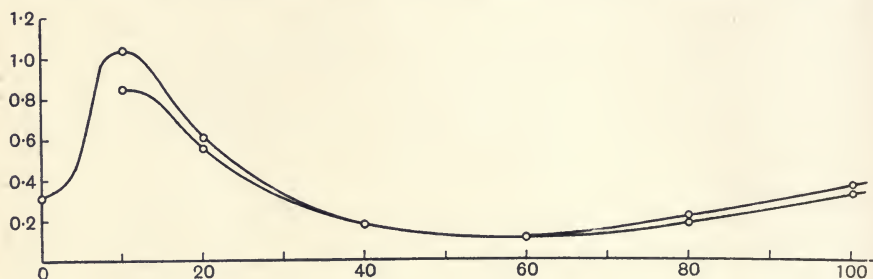

FIG. 187.

Victoria Street, where I made twelve measurements of maxima and minima. I then returned to Whitehall and repeated the observations, thus ensuring that no error could be caused by variation in the power of the electric lamp in the photometer. The measurements were in accordance with the results which have been given. An attempt to read a Bellows' French Dictionary at different parts of the street seemed to show that the light in Queen Victoria Street was rather more useful, but the lighting in Whitehall was certainly less dazzling.

Modern Practice.—Since the subject of this book is the distribution and measurement of illumination, detailed descriptions of the lighting of streets and other places would be somewhat beyond its scope. Moreover, keen competition and improvements in gas and electric lamps were raising the standard of street illumination so rapidly when this book went

to press, that it seemed useless to occupy space with recent measurements.

H. Harrison's papers of 1905* and 1910,† and Edgcumbe's article ‡ in 1907, give many examples of street lighting. Discussions at the Illuminating Engineering Society of London showed that illumination of 2 or 3 foot-candles is a common standard in libraries and schools, 5 to 7 foot-candles for drawing-boards in drawing offices, and as much as 12 to 14 foot-candles at the work benches in certain technical schools.

Ordinary Streets, Theatre Lighting, etc.—Measurements of the illumination in streets lighted by the ordinary "5-foot" flat flame gas lamp were made on several occasions. The illumination is so very feeble that exact measurement is very difficult. The maximum rarely exceeded 0.9 candle-foot. The illumination near the foot of an ordinary gas lamp is very irregular, and is much cut up by the shadows of the lantern frame. Fig. 187A is the illumination curve along the curb of the foot pavement of Great George Street, Westminster.

A slight increase midway between the lamps is due to a lamp on the opposite side of the street. The minima were about 0.005 foot-candle, an il-

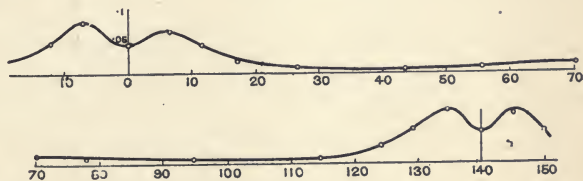

FIG. 187A.—ILLUMINATION CURVE ALONG THE CURB OF THE FOOT PAVEMENT OF GREAT GEORGE STREET, WESTMINSTER.

lumination a little greater than the value calculated by the cosine-cubed law. This was probably due to the reflection from surrounding buildings, or to general diffused light.

The illumination on the stage of the Lyric Theatre during the performance of *La Cigale* in the spring of 1891 was 3.8 foot-candles without the arc or lime-lights. On the stage of the Prince of Wales Theatre during the performance of *Maid Marian* the illumination was 2.9 foot-candles. The illumination in the trains of the Metropolitan and District

* *Journ. Inst. Elec. Eng.* xxxvi. 188.

† *Ibid.* xlvi. 24.

‡ *Electrical Engineering*, ii. 5.

Railways was measured on many occasions, and varied from 0.3 to 0.9 foot-candle, the photometer being held breast-high.

Characteristic Curves.—The results of the above-described measurements are summed up in Fig. 187B, as characteristic curves. The ordinates are foot-candles, and the horizontal scale is a percentage scale of areas. The maximum is 100. No. 1 is the characteristic of Queen Victoria Street on the

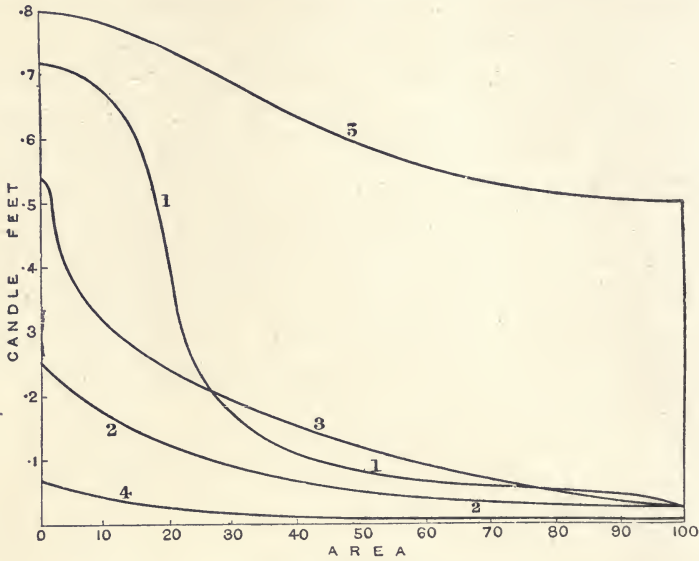

FIG. 187B.—CHARACTERISTIC CURVES OF PRECEDING CASES.

assumption that the lights are all burning at their best, as in Fig. 175. No. 2 is the characteristic of the same street on the assumption that the lamps are at their worst, having just fed. No. 3 is the characteristic of Whitehall, the moon-light having been deducted. It appears that about one-half of the area was better lighted than Queen Victoria Street. No. 4 is the characteristic of an ordinary gas-lit street. No. 5 is the characteristic, estimated approximately only, of the Architecture Court of the South Kensington Museum.

CHAPTER XII

DIOPTRIC DISTRIBUTION AND DIFFUSION OF LIGHT

IN about the year 1878 arc-lamps had arrived at a practical stage, though carbons were for the most part of poor quality. It was not found possible to use a less current than 9 amperes, and each lamp was supposed to take one horse-power, and to give from 1000 to 1500 candle-power. The Jablochkoff lamp dispensing with mechanism promised, but without fulfilment, to provide a smaller source of light. With this lamp the Avenue de l'Opera in Paris was lighted during 1878 to 1881. Sixty-four Jablochkoff "candles" set 30 yards (27 m.) apart replaced 300 gas-burners and gave fully 20 times as much light as gas, and a good deal more than at that time appeared to be needed or reasonable. Part of the City of London was lighted experimentally with Brush lamps of about 9 amperes, and part, including the space in front of the Royal Exchange and Poultry, with Siemens lamps taking 30 amperes, set on lofty posts at a height of 80 feet (24 m.) from the ground, and others in Cheapside with 12-ampere lamps about 20 feet high. This was before Sir William Preece's first experiments in illumination photometry, and there is no record of the illumination produced, but the result was very good.

The illumination was very uniform, owing, of course, to the great height of the lamps. But it was evident that though such a mode of lighting might do for large open spaces, it would not be practicable for ordinary streets. A large part of the light would be thrown upon the buildings and wasted. Even to-day narrow streets cannot be lighted economically by arc-lamps. The difficulty was recognized, and it was expressed as

a desire for the "subdivision of the electric light." This problem of subdivision was constantly alluded to by lecturers and writers. All attempts to produce an arc-lamp that would work with four or five amperes failed. The glow-lamps of Swan, Lane Fox, and Edison were just making their appearance, but the watts per candle were so large compared with the arc, that this development was not admitted to be a solution to the problem.

It occurred to me in 1879 that the difficulty was not so much that of large candle-power, as of the excess of illumination in the neighbourhood of the lamp, and the desirability of distributing this excess to the more remote parts of a definite area. In those days the light of arc-lamps was thought to be approximately proportional to the square of the current, and in

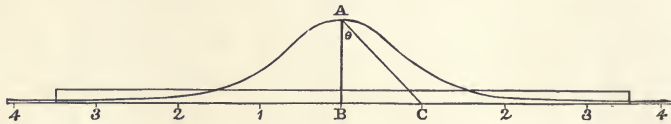

FIG. 188.*

addition to this it seemed desirable to reduce the number of lamps to a minimum from the considerations of first cost and of trimming. It was natural to suppose that a uniform distribution of illumination was desirable, and it was not until many years later that I recognized that a moderate diversity is much more satisfactory.

Let AB , Fig. 188,* represent the height of the lamp A , which gives the same candle-power in all directions. Let AB also represent the illumination at the point B . Then, as has been shown on page 27, the illumination at C is $\cos \theta / AC^2$ or $\cos^3 \theta$ when the height is unity. The solid contents of the figure of revolution of the curve so obtained is 2π . Let the diameter of the circle to be uniformly illuminated be seven times the height of the lamp above the ground, then the illumination at any point will be represented by the height of a

* Figs. 188 to 195 and 197 and 198 have been reproduced from my paper on "A Dioptric System of Uniform Distribution of Light," *Proc. Inst. Civ. Eng.* vol. lxxviii. (1884), by permission of the Council of the Institution.

cylinder whose diameter is seven times its length and whose volume is 2π . This is 0.163.

Suppose the whole area to be divided into annuli of equal area, the radii being $\sqrt{1}$, $\sqrt{2}$, $\sqrt{3}$, etc., the same quantity of

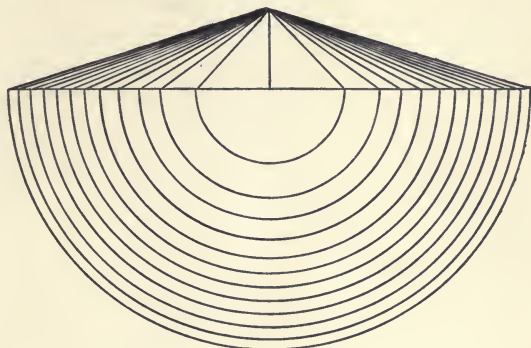

FIG. 189.

light is to be directed to each annulus. Rays in any vertical plane, emanating at equal angles with each other, have to be deflected so that the tangents of their new inclinations to the vertical are as $\sqrt{1}$, $\sqrt{2}$, $\sqrt{3}$, etc., Fig. 189.

This cannot be done by a reflector below the lamp, but the rays in the upper hemisphere can be directed by a suitably designed reflector in this manner, and those in the lower

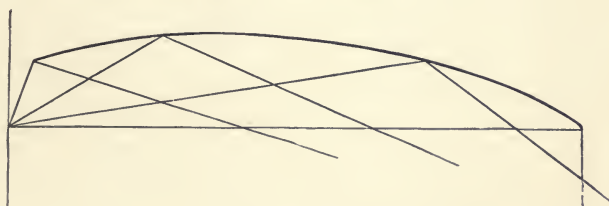

FIG. 190.

hemisphere can be thrown on to that reflector by a hemispherical reflector.* But this did not seem to be a practical idea. I afterwards found that a reflector intended to produce this result, but erroneously designed, had been patented by Smethurst and Paul in 1802.

* *Industries*, v. 532 (1888).

The required deflection of the rays can be produced by refraction. Let the diameter of the circle to be uniformly illuminated be seven times the height of the lamp above the ground. Dealing with the light in the lower hemisphere, the horizontal ray has to be deviated through $15^{\circ} 48'$ to reach the edge of the circle. If the light makes an angle of incidence of 45° on glass of refractive index 1.51, the deviation on entering the glass is 17° , and a prism of $24^{\circ} 30'$ is required to produce the required deflection. Assuming a right-angled cone for the interior face of the glass, and taking 20 or 30 rays, the refracting angle for each was calculated and a smooth curve was

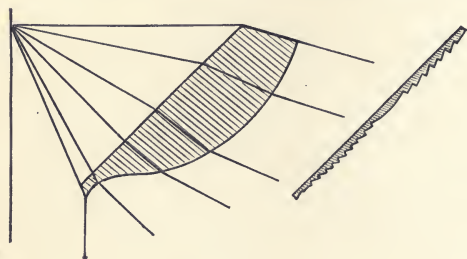

FIG. 191.

drawn through the polygon thus found. To avoid a greater thickness of glass, zones or surfaces in echelon may be arranged, Fig. 191.

But this idea was abandoned since the light from an arc-lamp is not uniformly distributed. I therefore designed a number of prismatic zones of such curvature that (whatever might be the distribution of light from the lamp) the light passing through each was distributed in the required proportion over as much of the area as possible without so near an approach to the critical angle as to incur risk of total internal reflection. These prisms (as they may be inaccurately called for want of another name) were calculated with a base 7 or 8 inches long. The curves were reduced by a pantograph on to sheet brass. Templates were cut to the curves, steel tools were ground to fit these templates, and a cast-iron mould was grooved with the tools. Panes of glass 14 inches (356 mm.) long, 8 inches (203 mm.) wide at one end and 2 inches (51 mm.) at the other, were pressed in the moulds, and ten such panes were fitted into lanterns 2 feet 6 inches (762 mm.) in diameter. The vertical or longitudinal section of the pane in Fig. 192 shows the prisms. Fig. 193 re-

presents them four times full size. Fig. 194 shows a complete lantern.

The production of a pane of glass of this size and the need for accurate shaping of the prisms presented such difficulties

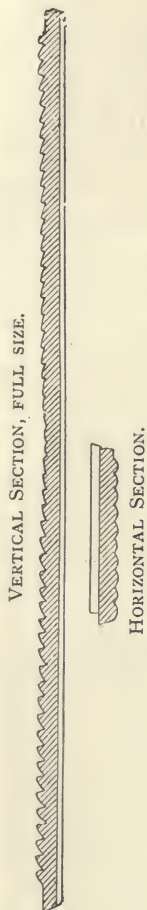

FIG. 192.

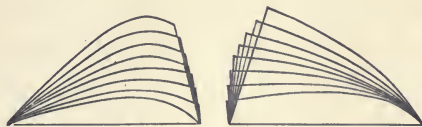

FIG. 193.

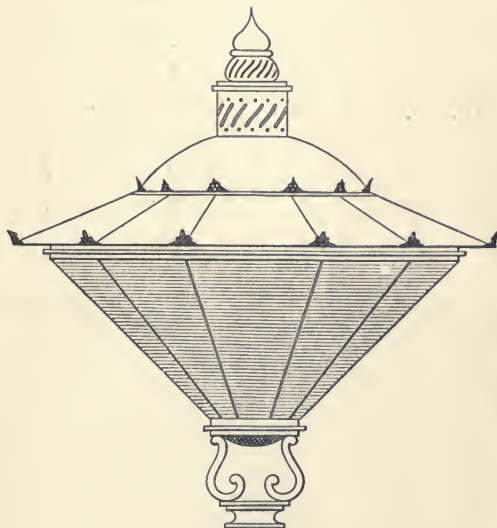

FIG. 194.

that the work was declined by some half-dozen of the flint glass manufacturers. The glass was eventually produced by Messrs. E. Moore & Co. of South Shields. A smaller pattern, consisting of a cone 12 inches (305 mm.) in diameter, in one piece, Fig. 196, was even more difficult, but was successfully made by the same makers. No experi-

ments of any kind were possible until the finished shade was produced.

While this design was in progress, electric glow-lamps began to appear. It seemed likely that improvements in manufacture would enable them to be run at such high incandescence that they would be painfully dazzling, though so far as carbon glow-lamps are concerned this anticipation was never realized. I therefore considered the production of a clear glass shade which might be used instead of ground or opal glass for softening the light. A double system of flutings as shown four times full size in Fig. 195 was designed for this purpose. Five parallel rays of light falling on the curved surface are shown refracted through 0° , 10° , 20° , 30° , and 40° . At right angles with these another set of similar flutings was arranged on the other side of the glass. Considerable care was taken by calculations of angles in three dimensions to avoid total internal reflection. Such flutings were provided on the large

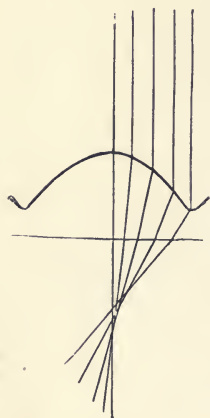

FIG. 195.

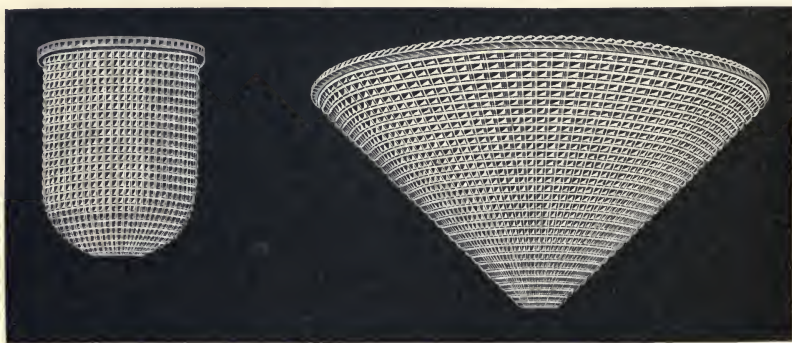

FIG. 196.

lantern panes, as shown in the horizontal section in Fig. 192, and on the interior of the 12-inch cone, and the combination of the two sets of flutings for diffusion only was used for shades 4 inches in diameter, and $5\frac{1}{2}$ inches deep, as shown in Fig. 196.

The effect of the crossed flutings was to produce a number of lenses. About 300 images of the source of light are produced by a shade, and so accurately are they formed, and so excellent is the surface of the glass, that by the use of a convex

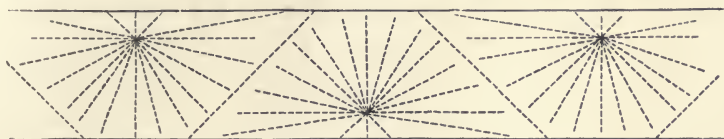

FIG. 197.

lens each of these will throw a well-defined image of a lamp filament on a screen.

The calculation of the polygonal surfaces through which the curves were drawn was laborious, and only became possible by the help of an instrument which I designed for the purpose. (See Appendix.)

One set of curves for a single pane of glass involved nearly 2000 separately calculated angles. About 500 were required to produce the set of curves shown in Fig. 193 in one plane, the rest being three-dimensional calculations for avoiding total internal reflection of the rays already deflected by the internal diffusing flutings. Designs were prepared for an 18-inch (457 mm.) globe, and for a lantern to distribute light in a street as shown in Fig. 197. But I became occupied with more important work, the dioptric shades were not pushed, and the sales, which fell into unfortunate hands, gradually diminished.

Fig. 198 is a profile, about six times full size, of a compound fluting employing total internal reflection as well as refraction, and giving diffusion over about 150° . The template and tool were made for this, but no glass shades were turned out.

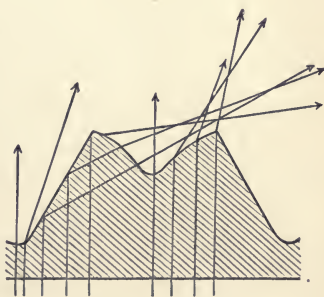

FIG. 198.

The foregoing account of what I called my dioptric system of uniform distribution and diffusion of light must suffice.

Further details may be found elsewhere.* The results were encouraging except when purchasers of the panes built their own lanterns with eight sides instead of ten. A considerable number were sold in 1884 and 1885. A silver medal was awarded for the invention at the Health Exhibition, where one of the large galleries was lighted with the lanterns, and some of the corridors with the smaller shades. One drawback to any such device is that it must be calculated with reference to some definite point as a source of light, while in practice that point is continually varying in most arc-lamps, and in the case of glow-lamps or incandescent gas lamps is so widely different from a point that most of the calculations are useless.

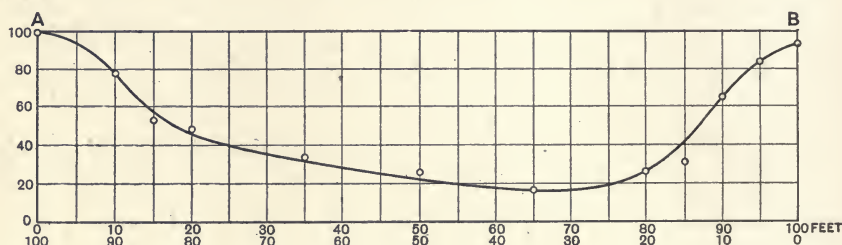

FIG. 199.

The only photometric tests of absorption or loss of light by these shades that I obtained, some made by myself and others by Mr. Stepney Rawson, were too good to be true. I have, however, the results of measurements made with one of Sir W. Preece's early photometers, in connection with his experimental lighting at Wimbledon in 1884, among which are the following:—Fig. 199 is the illumination curve between two 20 c.p. Swan lamps on posts 14 feet (4.26 m.) high. The lamp at A had a flat polished nickel reflector about 12 inches (305 mm.) in diameter tangent to the bulb of the lamp, that is, the stalk of the lamp passed through the reflector, and the lamp at B had a concave zinc reflector, the concave side being downwards and painted white, as now recommended by Mr.

* *Proc. Inst. Civ. Engs.* lxxviii. 346 (1884); *La Lumière électrique*, xiv. 98 (1884); *The Electrical Review*, xxv. 707 (1894). British Patent Specification, 3515 (1881), and 233 (1883); American, 330, 356 (1885); French, 153, 303 (1883); Belgian, 60, 328 (1883); Austrian, 7, 228 (1884).

Haydn Harrison. Fig. 200 is the curve for a lamp at C with a convex white reflector, the lamp at D being a plain lamp with no reflector. Fig. 201 is for a 50 c.p. lamp in a 12-inch dioptric cone shade 20 feet (6 m.) from the ground. The dotted line shows the curve which would have been obtained if

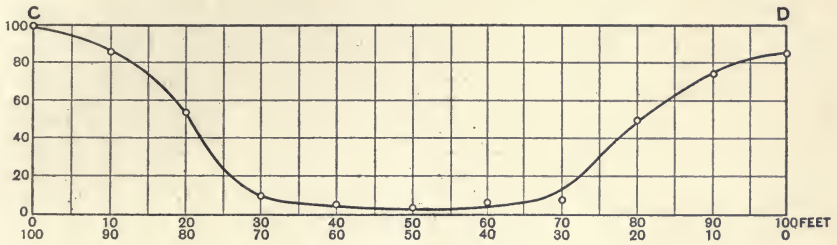

FIG. 200.

another similar lamp had been set at 140 feet distance. I have lost the figures, and have no note of the actual illuminations; they are plotted to an arbitrary scale. Each observation is recorded, some being obviously erratic. Scientifically, the result of the dioptric cone was most gratifying, but practically the white reflectors were quite as good, if not better.

Louis Émile Ossian Degrand, "Gentleman of Paris in the French Empire," patented in 1857 a number of designs for lanterns made of ribbed or prismatic glass. Some of these were "intended to shed strong streams of light up and down

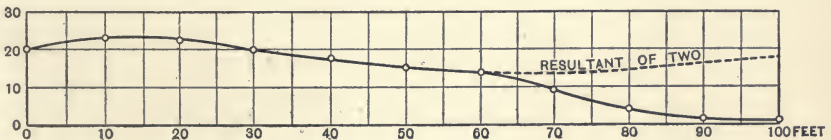

FIG. 201.

the street," others were for domestic purposes, and others for lighthouses. These were intended for use with oil lamps. In his patent, No. 1235 of 1875, Pulford shows several forms of prismatic lanterns, and in 1890 Fredureau, in his French patent, gives some almost identical designs. Fig. 202 illustrates one of these. None of these inventors suggests the uniform distribution of light, and although some of them used crossed

flutings, they did not make any systematic attempt to reduce glare by this device.

In about 1892 Blondel and Psaroudaki* took the matter up and developed it considerably. In 1893, while they were engaged on the calculations, they heard that my dioptric shades had been made. They used total internal reflection as well as refraction, but the profiles of the prisms were so intricate that the difficulties of reproduction in pressed glass must have been very great. Fig. 203, one of the numerous illustrations of Blondel and Psaroudaki's patent

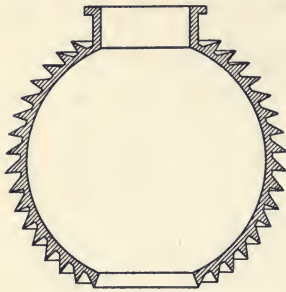

FIG. 202.

specification,† shows the action of a diffusing fluting. They aimed at a much wider dispersion than I thought wise. It is evident that a source of light of an appreciable size compared with the shade, or the curvature of the second surface in a plane at right angles to the figure, would cause total internal reflection.

Fig. 204 is a typical distributing prism. The surfaces ab and cd are refracting, and the surface bc is totally reflecting, provided that the source of light is in exactly the right position. Their shades were made by Engelfried et Cie of Paris, but it was not until the invention was energetically developed at great expenditure in America that it became the well-known success under the name Holophane.

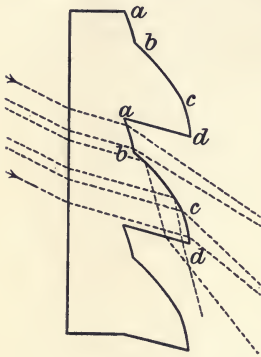

FIG. 204.

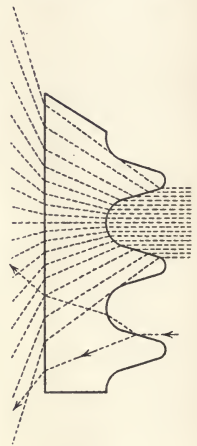

FIG. 203.

Few of the large number of different patterns of Holophane

* *Bulletin de la Soc. Française de Physique*, March 17, 1893, p. 84; *L'Industrie électrique*, Oct. 10, 1894, No. 67, p. 438; *L'Eclairage électrique*, Oct. 27, 1894, No. 7, p. 308; *L'Étincelle électrique*, Nov. 3, 1894; *The Electrical Review*, xxxvi. 183 (1895).

† British Patent, No. 19,185, 1893.

shades have been designed with the view of the uniform distribution of light on a plane, most of them are intended to give well developed diffusion, the name Holophane implying that the whole surface of the shade appears full of light; or they are intended also to cast the light downwards. Another class of Holophane shade is purely for reflecting. The principle of total reflection is used. This had been suggested by Degrand in 1857, and by Taylor (Patent No. 10,384) in 1884. The novel feature of the Holophane reflectors is the curvature by which the light is concentrated or spread in a variety of ways for different purposes.

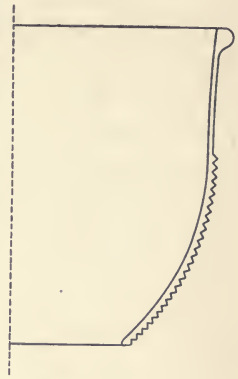

FIG. 205.

The dioptric system is better applicable to arc-lamps with a fixed focus than to those in which the position of the source of light alters. The large size of my lanterns, entailing great

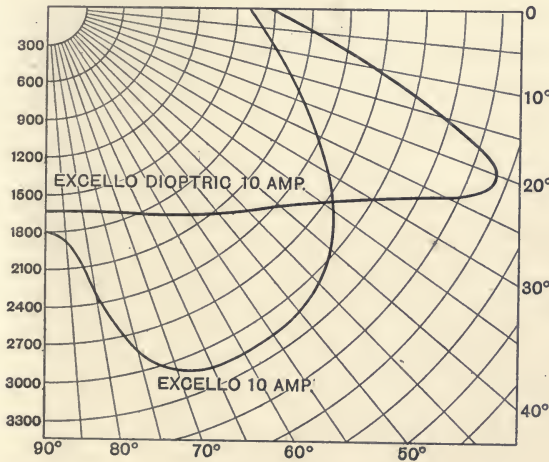

FIG. 206.

weight and expense, was to reduce the angular variation of the source of light as the lower carbon burned away. Fig. 205 is a section of a shade by Messrs. Korting and Mathieson, and supplied by the Union Electrical Company. There are no dispersion flutings. The prisms in this respect resemble

those of Fredureau, but their action shows that they follow the lines of my invention. The effect with an Excello focus lamp is very good. Fig. 206 gives the polar curve of an ordinary arc, of a flame arc, and of a flame arc with one of these

shades. Similar diagrams will be found in a valuable paper by Haydn Harrison.*

Peard has designed a dioptric reflector † consisting of an inverted cone of clear glass with reflecting prisms on its outer surface. It is placed below a focussing arc-lamp. Rays of light between the horizontal and about 35° do not strike the cone, but the more vertical rays which would have fallen at greater angles with the horizon are deflected at smaller angles. In other words, the excess of illumination in the neighbourhood of the lamp is distributed to the more remote parts.

* *Journ. Inst. Elec. Eng.* vol. xlvi. 24, 1910.

† *The Electrician*, lxvi. p. 365, 1910.

APPENDIX

TABLE I

ROUND NUMBERS OF $\text{Cos}^3\theta$

$\text{Cos}^3\theta$.	$\text{Cos}\theta$.	θ .	$\text{Tan}\theta$.	$\text{Cos}^3\theta$.	$\text{Cos}\theta$.	θ .	$\text{Tan}\theta$.
0.995	0.998	3 20	0.058	0.360	0.711	44 39	0.988
0.990	0.997	4 43	0.083	0.340	0.698	45 44	1.026
0.980	0.993	6 38	0.116	0.320	0.684	46 51	1.067
0.960	0.987	9 25	0.166	0.300	0.669	47 59	1.110
0.940	0.980	11 35	0.206	0.280	0.654	49 8	1.156
0.920	0.973	13 27	0.239	0.260	0.638	50 20	1.206
0.900	0.966	15 5	0.270	0.240	0.621	51 35	1.261
0.880	0.958	16 36	0.298	0.220	0.604	52 52	1.321
0.860	0.951	18 1	0.325	0.200	0.585	54 13	1.387
0.840	0.944	19 21	0.351	0.190	0.575	54 54	1.423
0.820	0.936	20 36	0.376	0.180	0.565	55 37	1.461
0.800	0.928	21 50	0.401	0.170	0.554	56 21	1.502
0.780	0.921	23 0	0.425	0.160	0.543	57 7	1.547
0.760	0.913	24 8	0.448	0.150	0.531	57 54	1.594
0.740	0.905	25 15	0.472	0.140	0.519	58 43	1.646
0.720	0.896	26 20	0.495	0.130	0.507	59 34	1.702
0.700	0.888	24 23	0.518	0.120	0.493	60 27	1.764
0.680	0.879	28 26	0.542	0.110	0.479	61 22	1.832
0.660	0.871	29 28	0.565	0.100	0.464	62 20	1.907
0.640	0.862	30 29	0.589	0.090	0.448	63 23	1.995
0.620	0.853	31 30	0.613	0.080	0.431	64 28	2.093
0.600	0.843	32 30	0.637	0.070	0.412	65 40	2.211
0.580	0.834	33 29	0.662	0.060	0.392	66 57	2.350
0.560	0.824	34 29	0.687	0.050	0.368	68 23	2.524
0.540	0.814	35 29	0.713	0.040	0.342	70 0	2.747
0.520	0.804	36 29	0.740	0.030	0.311	71 54	3.059
0.500	0.794	37 28	0.766	0.020	0.271	74 15	3.546
0.480	0.783	38 28	0.795	0.010	0.215	77 34	4.536
0.460	0.772	39 28	0.823	0.008	0.200	78 27	4.893
0.440	0.761	40 29	0.854	0.005	0.171	80 9	5.759
0.420	0.749	41 30	0.885	0.002	0.126	82 46	7.880
0.400	0.737	42 32	0.917	0.001	0.100	84 15	9.931
0.380	0.724	43 35	0.952				

TABLE II

Cos³ θ . ROUND NUMBERS OF θ

θ .	Cos ³ θ .	θ .	Cos ³ θ .
2	0.998	40	0.449
4	0.993	42	0.410
5	0.989	44	0.372
6	0.984	45	0.354
8	0.971	46	0.335
10	0.955	48	0.300
12	0.936	50	0.266
14	0.914	52	0.233
15	0.901	54	0.203
16	0.888	55	0.189
18	0.860	56	0.175
20	0.827	58	0.149
22	0.797	60	0.125
24	0.761	62	0.1035
25	0.744	64	0.0843
26	0.726	65	0.0755
28	0.688	66	0.0673
30	0.650	68	0.0526
32	0.610	70	0.0400
34	0.570	72	0.0295
35	0.550	75	0.0173
36	0.530	80	0.0052
38	0.489	85	0.00066

TABLE III

POWERS OF $\text{Cos}\theta$. ROUND NUMBERS OF $\text{TAN}\theta$

Tan θ .	θ	Cos θ .	Cos ² θ .	Cos ³ θ .	Cos ⁴ θ .
0.5	2 52	0.9987	0.9970	0.996	0.991
0.10	5 43	0.9950	0.9900	0.985	0.982
0.20	11 19	0.9806	0.9616	0.943	0.922
0.30	16 42	0.9578	0.9174	0.879	0.841
0.40	21 49	0.9284	0.8620	0.800	0.743
0.50	26 34	0.8944	0.8000	0.715	0.640
0.60	30 58	0.8575	0.7350	0.630	0.540
0.70	35 0	0.8191	0.6710	0.549	0.450
0.80	38 40	0.7808	0.6100	0.476	0.372
0.90	42 0	0.7431	0.5520	0.410	0.305
1.00	45 0	0.7071	0.5000	0.353	0.250
1.10	47 44	0.6726	0.4520	0.305	0.204
1.20	50 12	0.6401	0.4097	0.262	0.168
1.30	52 26	0.6097	0.3710	0.226	0.138
1.40	54 28	0.5812	0.3380	0.196	0.114
1.50	56 19	0.5546	0.3070	0.171	0.0943
1.60	58 0	0.5299	0.2810	0.149	0.0790
1.70	59 33	0.5068	0.2570	0.130	0.0660
1.80	60 57	0.4856	0.2360	0.114	0.0557
1.90	62 15	0.4656	0.2170	0.101	0.0471
2.00	63 27	0.4470	0.2000	0.0893	0.0400
2.20	65 34	0.4136	0.1710	0.0709	0.0292
2.40	67 23	0.3846	0.1480	0.0568	0.0219
2.60	68 58	0.3589	0.1290	0.0463	0.0166
2.80	70 21	0.3363	0.1130	0.0380	0.0128
3.00	71 34	0.3162	0.1000	0.0316	0.0100
3.20	72 39	0.2982	0.0888	0.0265	0.00788
3.40	73 37	0.2821	0.0795	0.0224	0.00632
3.50	74 3	0.2748	0.0756	0.0208	0.00571
4.00	75 58	0.2425	0.0597	0.0142	0.00356
4.50	77 29	0.2167	0.0468	0.0102	0.00219
5.00	78 42	0.1959	0.0384	0.00752	0.00147
5.50	79 42	0.1788	0.0320	0.00573	0.00102
6.00	80 33	0.1642	0.0269	0.00441	0.000724
6.50	81 16	0.1518	0.0231	0.00351	0.000534
7.00	81 53	0.1412	0.0199	0.00280	0.000396
7.50	82 24	0.1323	0.0174	0.00230	0.000303
8.00	82 53	0.1239	0.0154	0.00190	0.000237
8.50	83 17	0.1169	0.0137	0.00160	0.000188
9.00	83 40	0.1103	0.0121	0.00133	0.000146
9.50	84 0	0.1045	0.0109	0.00113	0.000119
10.00	84 18	0.0993	0.0099	0.00099	0.000098

TABLE IV

COMBINATIONS APPROXIMATELY EQUAL TO ONE FOOT-CANDLE

Candle-Power.	Ft. In.	Candle-Power.	Ft. In.
0.25	0 6	64	8 0
1	1 0	100	10 0
4	2 0	144	12 0
8	2 10	200	14 2
9	3 2	400	20 0
10.8	3 3 $\frac{3}{8}$	600	24 6
16	4 0	1000	31 8
20	4 6	1600	40 0
30	5 6		

TABLE V

SCALE FOR A PHOTOMETER BAR WITH A FIXED SOURCE OF LIGHT AT EACH
END, AND A MOVABLE PHOTOMETER HEAD

Total Length, 100 units.

Graduation No. or Ratio.	Length.	Graduation No. or Ratio.	Length.	Graduation No. or Ratio.	Length.	Graduation No. or Ratio.	Length.
40	13.65	7.2	27.15	2	41.42	0.82	52.48
30	15.44	7	27.43	1.95	41.73	0.8	52.79
25	16.67	6.8	27.72	1.9	42.04	0.78	53.10
24	16.95	6.6	28.02	1.85	42.37	0.76	53.42
23	17.26	6.4	28.33	1.8	42.71	0.74	53.76
22	17.57	6.2	28.65	1.75	43.05	0.72	54.10
21	17.91	6	28.99	1.7	43.41	0.7	54.44
20	18.27	5.8	29.34	1.65	43.77	0.68	54
19.5	18.47	5.6	29.70	1.6	44.15	0.66	55.17
19	18.66	5.4	30.09	1.55	44.55	0.64	55.56
18.5	18.86	5.2	30.48	1.5	44.95	0.62	55.95
18	19.07	5	30.90	1.45	45.37	0.6	56.35
17.5	19.29	4.8	31.34	1.4	45.81	0.58	56.77
17	19.52	4.6	31.80	1.38	45.97	0.56	57.20
16.5	19.75	4.4	32.28	1.36	46.16	0.54	57.64
16	20	4.2	32.79	1.34	46.35	0.52	58.10
15.5	20.26	4	33.33	1.32	46.54	0.5	58.58
15	20.52	3.9	33.62	1.3	46.72	0.48	59.07
14.5	20.80	3.8	33.90	1.28	46.92	0.46	59.59
14	21.09	3.7	34.20	1.26	47.11	0.44	60.12
13.5	21.39	3.6	34.51	1.24	47.31	0.42	60.68
13	21.72	3.5	34.83	1.22	47.52	0.4	61.25
12.5	22.05	3.4	35.16	1.2	47.72	0.38	61.86
12	22.40	3.3	35.50	1.18	47.93	0.36	62.50
11.5	22.77	3.2	35.86	1.16	48.15	0.34	63.17
11	23.17	3.1	36.22	1.14	48.36	0.32	63.87
10.5	23.59	3	36.60	1.12	48.58	0.3	64.61
10	24.03	2.9	37	1.1	48.81	0.28	65.39
9.8	24.21	2.8	37.41	1.08	49.04	0.26	66.23
9.6	24.40	2.7	37.83	1.06	49.27	0.24	67.12
9.4	24.60	2.6	38.28	1.04	49.51	0.22	68.07
9.2	24.79	2.5	38.75	1.02	49.75	0.2	69.10
9	25	2.45	38.98	1	50	0.18	70.21
8.8	25.21	2.4	39.23	0.98	50.26	0.16	71.43
8.6	25.43	2.35	39.48	0.96	50.51	0.14	72.77
8.4	25.65	2.3	39.73	0.94	50.77	0.12	74.27
8.2	25.88	2.25	40	0.92	51.04	0.1	75.98
8	26.12	2.2	40.27	0.9	51.31	0.08	77.95
7.8	26.37	2.15	40.55	0.88	51.60	0.06	80.32
7.6	26.62	2.1	40.83	0.86	51.88	0.04	83.33
7.4	26.88	2.05	41.02	0.84	52.18	0.02	87.61

Refraction Goniometer.—This instrument was shown and described at the Physical Society in 1889. The following account and illustrations appeared in *Engineering*, vol. xlvii. p. 559. It is based upon a graphical construction given in Deschanel's *Physics*. Two bars *a* and *b*, Fig. 1, are pivoted on a centre *c*, the contained angle *D* being measured by a graduated scale carried by one of them. At *e* and *d* are two knife edges. Against these the two bars *f* and *g* are brought to bear. These bars are pivoted at *h* on a slide. The ratio of the distance *ch* to *ce* being the refractive index of the prism.

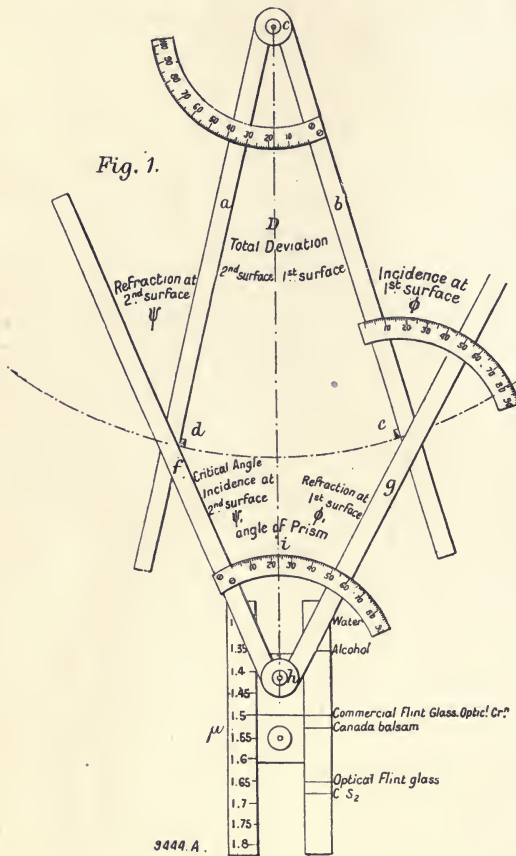

FIG. 1.

By construction $\sin \phi$ bears the same ratio to $\sin \phi'$ as $\sin \psi$ to $\sin \psi'$. The angle i is the refracting angle of the prism, being the sum of ϕ' and ψ' . Graduated arcs are provided to measure this angle, and the angle of incidence on the first surface.

A series of values of ϕ and D being given, it is easy to find values of i at the rate of six per minute; the angles could be read to about a quarter of a degree.

The diagram Fig. 3 in the bottom right-hand corner represents a prism with a refracting angle i , angle of incidence on the first surface ϕ , angle of refraction at the first surface ϕ' , incidence on the second surface ψ' , and refraction at the second

surface ψ . The incident and emergent rays being produced as dotted lines meet at D and form the angle of total deviation.

The family of curves, Fig. 2, represent the angles of prisms of refractive index 1.5 for any angle of incidence and total

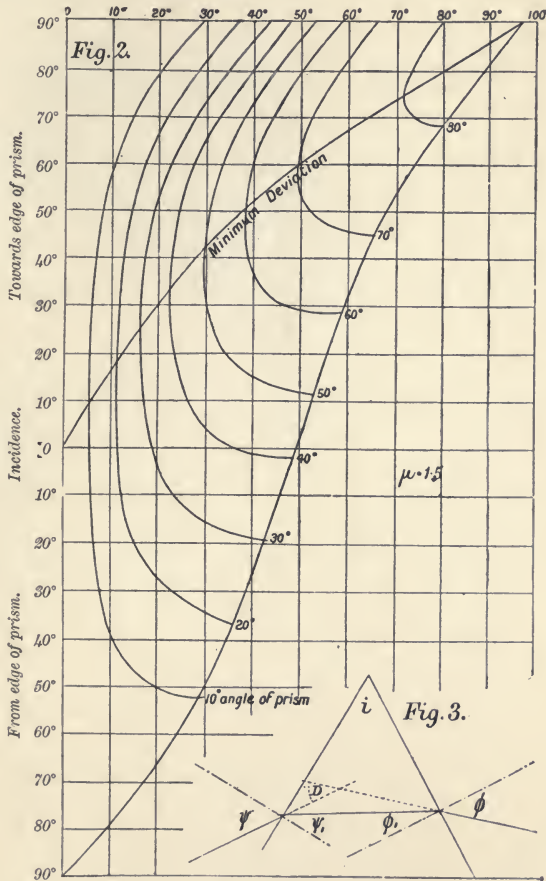

FIGS. 2 AND 3.

deviation. The vertical scale represents angles of incidence, and the horizontal scale angles of deviation. The point of osculation of any curve with the vertical is the point of minimum deviation for that prism; a line has been drawn through those points. The curves are terminated at one end by 0 degrees incidence, and at the other end by total internal

reflection. The limiting angle of maximum deviation for $\mu = 1.5$ is 97° with a prism of 85° .

I gave away this instrument some years ago, and having occasion to make some similar calculations I have recently made a diagram, Fig. 4, which is self-explanatory. The

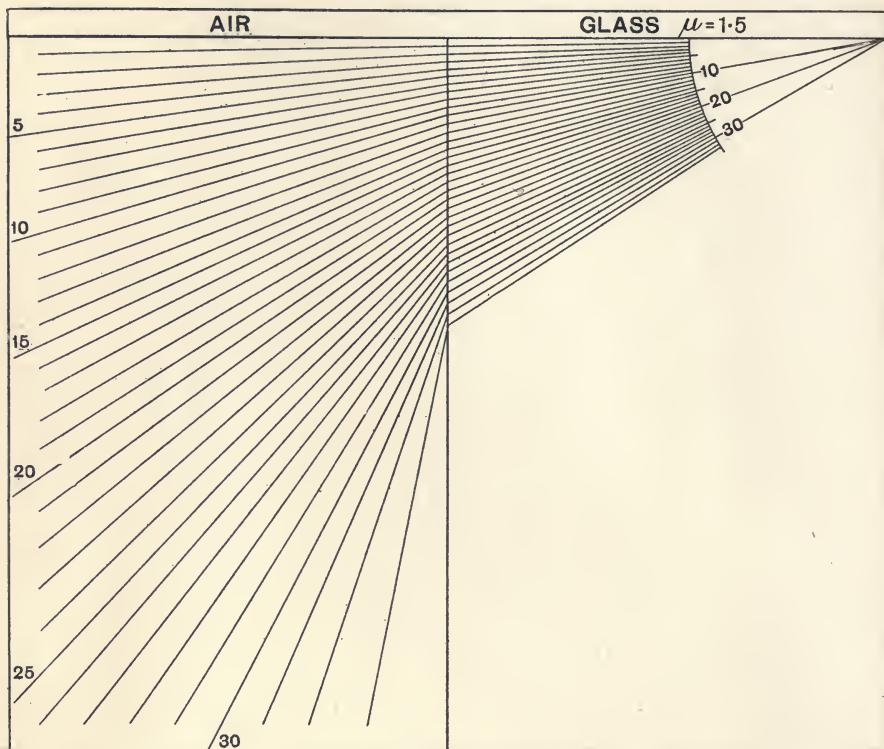

FIG. 4.

diagram is drawn in bold lines on a sheet of card, and the constructive work is done on a sheet of tracing-paper placed upon it. Or the lines may be drawn on tracing-paper or a sheet of celluloid, and any required line or interpolated value between two lines may be transferred by placing a ruler over it, and then withdrawing the diagram.

BIBLIOGRAPHY

The following is an index of authors quoted. B.M. refers to the British Museum Press mark; and the figures in brackets, to the General Catalogue of the Patent Office Library, London. Dr. J. A. Fleming's paper in Vol. XXXII. of the Journal of the Institution of Electrical Engineers (1903) contains a good bibliography on photometry.

- ABNEY, Sir W. DE W. Phil. Trans. Roy. Soc. clxxviii. clxxxiii. clxxxv. etc.
 Colour Measurement and Mixture, London, 1891. (22827.)
 Colour Vision, London, 1894. (24294.)
 Cantor Lecture, Soc. of Arts, vol. v., 1894. (19945.)
 Journ. Inst. Elec. Eng. (discussion), 1903, vol. xxxii. p. 178.
- AYRTON, Prof. W. E. and MEDLEY. Tests of Glow-Lamps, Proc. Phys. Soc. vol. xiii., and Phil. Mag. vol. xxxix. p. 389, 1895. (C. 798.)
 Journ. Inst. Elec. Eng. (discussion), 1903, vol. xxxii. p. 198.
- AYRTON, HERTHA, (Mrs.). The Electric Arc, London, 1902.
- BARR, J. M. and C. E. S. PHILLIPS. (Precision of Photometers.) The Brightness of Light, its Nature and Measurement. The Electrician, vol. xxxii. p. 525, 1894.
- BLONDEL, A. The Continuous Current Arc as a Standard of Light. The Electrician, vol. xxxii. p. 117, 1893.
 Photometric Magnitudes. The Electrician, vol. xxxiii. p. 633, 1894.
 Mean Spherical Candle-power. Comptes rendus, Ac. des Sci., March and April 1895 (B. 26); and L'Éclairage élect., 1895. (W. 51.)
 Rapport sur les unités photométriques. Cong. Int. des Élec., Geneva, 1896.
 Bulletin Soc. Int. des Élec., 2nd Series, vol. iv. p. 39.
 (Photometer.) Ill. Eng. Lond. vol. iii. p. 311, 1910.
- BOUGUER, P. Essai d'optique, Paris, 1729. B.M. 537, a, 31.
 Mém. de math. et de phys. Ac. des Sci., Paris, 1757.
 Traité d'optique, Paris. Ac. Roy. des Sci., 1760. B.M. 733, f, 13.
- BROCA, A. Investigations on the Visual Sensations and on Photometry. Journ. de Phys., May 1894 (D. 1); and The Electrician, vol. xxxiii. p. 752, 1894.
- CONROY, Sir JOHN. (Photometer.) Proc. Roy. Soc. vol. xxxv. p. 28, and Phil. Mag. vol. xv. p. 425, 1883. (C.)

- CROVA. (Colour Photometry.) Journ. de phys. vol. viii. ser. 2, p. 85, Paris, 1879. (D. 1.)
 Comptes rendus, Ac. des Sci., Paris, vol. xciii. p. 572, 1881. (B. 26.)
 Ann. de chim. et de phys. 6th ser. vol. vi. p. 528, 1885. (K. 1.)
 La Lum. élect. vol. xviii. p. 549, 1885. (D. 51, cont.)
- DIBDIN, W. J. Practical Photometry, London, 1889. (4907.)
- DOW, J. S. Colour Phenomena in Photometry. Proc. Phys. Soc. vol. xx. p. 245, 1906.
 Notes on Glow-Lamp Standards and Glow-Lamp Photometry. The Electrician, vol. lvii. p. 855.
 A Form of Cosine Flicker Photometer. Proc. Phys. Soc. vol. xxi. p. 36, 1908.
 Notes on the Physiological Principles underlying the Flicker Photometer. Proc. Phys. Soc. vol. xxii. p. 80, 1909.
 The Theory of the Flicker Photometer. The Electrician, vol. lviii. p. 607, 1907.
 Speed of Flicker Photometers. The Electrician, vol. lix. p. 157, 1907.
 and V. MACKINNEY. Lumeter. Optician and Photographic Trades Journal, Oct. 1910.
- Dutch Photometric Commission. Journal of Gas Lighting, Dec. 18, 1894. (K. 42.)
- DYKE, G. B. On the Practical Determination of the Mean Spherical Candle-Power of Incandescent and Arc Lamp. Proc. Phys. Soc. vol. xix., and Phil. Mag., Jan. 1905. (C.)
- FLEMING, Dr. J. A. Photometry of Electric Lamps. Journ. Inst. Elec. Eng. vol. xxxii. p. 119, 1903.
 Electric Secondary Standards of Light. British Assn. 1904, and The Electrical Engineer, Aug. 26, 1904.
- FOUCAULT, L. Photometer. Recueil travaux scientifiques, p. 100, Paris, 1878. B.M. 8704, g. 2.
- FOWLER, H. Railway Lighting. Proc. Inst. Mech. Eng., 1906, p. 867.
- HARRISON, HAYDN T. Street Lighting. Journ. Inst. Elec. Eng. vol. xxxvi. p. 188, 1905, and vol. xlvi. p. 24, 1910.
- HARCOURT, A. C. VERNON. Pentane Lamp. Chem. News. vol. xxxvi. p. 103, and vol. xliv. p. 243, 1877.
 Brit. Assoc. Reports, 1877, 1883, 1885, and 1898.
- HYDE, Dr. E. P. The Use of White Walls in a Photometric Laboratory. Bulletin of Bureau of Standards, Washington, vol. i. No. 3, 1905.
 Talbot's Law. Bulletin of Bureau of Standards, Washington, vol. ii. No. 1, 1906.
 and F. E. CADY. On the Determination of the Mean Horizontal Intensity of Incandescent Lamps. Bulletin of Bureau of Standards, Washington, vol. ii. No. 3, 1906.
 The Geometrical Theory of Radiating Surfaces. Bulletin of Bureau of Standards, Washington, vol. iii. p. 65, 1907.
 Comparison of Units of Luminous Intensity. Bulletin of Bureau of Standards, Washington, vol. iii. p. 65, 1907.
- JEVONS. (Errors.) The Principles of Science, London, vol. i. p. 452.

- JOLY, Dr. J. Photometer. *Phil. Mag.* vol. xxvi. p. 26, 1888. (C.)
- JONES, BASSET. The Mathematical Theory of Finite Light Sources. *Trans. Ill. Eng. Soc.*, New York, vol. iv. p. 216, 1909, and vol. v. p. 281, 1910.
- KENNELLY, A. E., and S. E. WHITING. Some Observations on Photometric Precision. *Nat. Elec. Light Assoc.*, New York, May 1908. (D. 50.)
The Frequencies of Flicker. *Nat. Elec. Assoc.*, New York, reprinted in *Ill. Eng.*, New York, ii. 347, 1907.
- KOLRAUSCH. (Errors.) An Introduction to Physical Measurements, London, 1894. (24, 204.)
- LAMBERT, J. H. *Photometria*. Augsburg, 1760. B.M. 537, e, 21.
- LEONARD. (Mean Spherical Candle-Power.) *L'Éclairage élec.* vol. xl. (D. 51.)
- LEPINAY, MACE DE, and A. NICATI. (Red and green screens and Purkinje effect.) *Comptes rendus*, vol. cxvii. p. 1428, 1882. (B. 26.)
La Lum. élec. vol. xii. p. 468, 1882. (D. 31.)
Journ. de phys. (2) 1, 33, and 86, 1882. (D. 1.)
- LIEBENTHAL, Dr. E. *Praktische Photometrie*. Brunswick, 1907.
The Effect of Barometric Pressure and Water Vapour on Hefner and Pentane Standards. *Zeitschr. für Instrumentenkunde*, vol. xv. p. 157, 1895. (D. 3.)
Journ. für Gasbel. vol. xlix. p. 559, 1906. (K. 39.)
- LUMMER, O., and E. BRODHUN. *Zeitschr. für Instrumentenkunde*, vol. ix. pp. 23 and 41, 1889. (D. 3.)
La Lum. élec. vol. xxxviii. (D. 51.)
- MCDUGALL, W. *The Journal of Psychology*, vol. i. p. 78, 1904, and iii. p. 178.
- MARECHAL. *L'Éclairage à Paris*.
- MARIE, PÈRE F. *Nouvelles Découvertes sur la lumière*, 1700.
- MASCART. *Traité de photométrie industrielle*.
- MATTHEWS, C. P. (Mean Spherical Candle-Power.) *Trans. Amer. Inst. Elec. Eng.* vol. xviii. p. 680, 1910. (D. 50.)
- MILLAR, PRESTON, S. *Illumination Photometers and their Use*. *The Illum. Eng. of New York*, vol. ii. p. 475, 1907.
- MORRIS-AIREY, H. Flicker Photometer. *Journ. Inst. Elec. Eng.* vol. xlv. p. 177, 1910.
- Netherlands Photometric Commission. *Journal of Gas Lighting*, Dec. 18, 1894. (K. 42.)
- NICATI, A. *See* Lepinay.
- NICHOLS, E. Personal Error in Photometry. *Trans. Amer. Inst. Elec. Eng.*, May 22, 1889. (D. 50.)
Early History of Standards of Light. *Amer. Illum. Soc.*, Dec. 1910.
Journ. of Gas Lighting, cxiii. 297, 1911. *Gas Engineers Mag.*, Feb. 1911.
- NUTTING, P. C. Fechner's Law. *Bulletin of Bureau of Standards*, Washington, vol. iii. p. 59, 1907.
- PATERSON, C. C. Investigations on Light Standards. *Journ. Inst. Elec. Eng.* vol. xxxviii. p. 271, 1907, and *The Electrician*, vol. lviii. p. 560, 1907.

- The Proposed International Unit of Candle-Power. Proc. Phys. Soc. xxi. 867, 1909.
- PALAZ, A. *Traité de photométrie industrielle*, Paris, 1892.
Translation by G. W. and M. P. Patterson, London, 1894.
- PETAVAL, J. E. An Experimental Research on some Standards of Light. Proc. Roy. Soc. vol. lxvi. 1899.
- PORTER, T. C. (Flicker Photometer.) Proc. Roy. Soc. vol. lxiii. p. 347, and vol. lxx. p. 313.
- PREECE, Sir W. H. On a New Standard of Illumination and the Measurement of Light. Proc. Roy. Soc. vol. xxxvi. p. 270, 1884.
Reports to the Commissioners of Sewers of the City of London, 1883 and 1884.
- PURKINJE. *Physiologie der Sinne*, vol. ii. p. 109.
- RITCHIE, W. Quarterly Journal of Science. Roy. Institution, vol. xxi. p. 376, 1826. (B. 3.)
Trans. Roy. Soc. Edin. vol. x. (B. 4.)
- ROOD, O. W. Flicker Photometer. Science, N.S. vol. vii. p. 757, 1898, and vol. viii. p. 11, 1898. (C. 2, 883.)
- ROSA, DR. E. B. Photometric Units and Nomenclature. Bulletin of Bureau of Standards, Washington, vol. vi. 543, 1910.
- RUMFORD, COUNT OF (B. THOMPSON). Roy. Soc. Phil. Trans. 1794, and Roy. Soc. Phil. Trans., abridged, vol. xvii.
Complete Works. Amer. Ac. of Arts and Sci., Boston, 1870-75.
- RUSSELL, A. Mean Spherical Candle-Power. Journ. Inst. Elec. Eng. vol. xxxii., 1603.
- STINE, W. M. Photometrical Measurements, London, 1900. (27, 446.)
- SUMPNER, W. E. The Diffusion of Light. Proc. Phys. Soc. vol. xii. p. 10, 1893; Phil. Mag. vol. xxxv. p. 81, 1893; The Electrician, vol. xxx. pp. 381, 411, 439, 1893.
The Direct Measurement of the Total Light emitted from a Lamp. The Ill. Eng. Lond. vol. iii. p. 323, 1910, and The Electrician, vol. lxxv. p. 72.
- SWAN, Sir J. Photometer. Trans. Soc. Edin. vol. xvi., 1849. (B. 4.)
Phil. Mag. vol. xl., 1900. (C.)
- SWEET, A. S. Analysis of Illumination Requirements in Street Lighting. Franklin Institute, Philadelphia, Mar. 13, 1910, and Ill. Eng. Lond. iii. 649.
- TALBOT, H. F. Experiments on Light. Phil. Mag., Brewster Series (Third), vol. v., 1834. (C. 798.)
- TROTTER, A. P. A Dioptric System of Uniform Distribution of Light. Proc. Inst. Civ. Eng. vol. lxxviii. p. 346, 1884.
Distribution and Measurement of Illumination. Proc. Inst. Civ. Eng. vol. cx. p. 69, 1892.
Notes on the Light of the Electric Arc. Journ. Inst. Elec. Eng. vol. xxi. p. 360, 1892.
- A New Photometer. Proc. Phys. Soc. vol. xiii. p. 354, 1893, and Phil. Mag., July 1893.
and W. H. PREECE. A Portable Photometer. The Electrician, vol. xxxv. p. 671.

- The Rotation of the Electric Arc. Proc. Phys. Soc. vol. lvi., 1894.
Accumulators and Portable Photometers. The Electrician, vol. lxvi.
p. 552, 1911.
- VIOLE, J. Sur la radiation du platine incandescent. Comptes rendus, Ac.
des Sci. vol. lxxxviii. p. 171, 1879, and vol. xcii. p. 866, 1883. (B. 26.)
Ann. de chim. et phys. vol. v. 3, 373, 1884. (K. 1.)
- WALDRAM, P. J. Daylight Measurement. Ill. Eng. Lond. vol. i. p. 811,
1908, vol. ii. p. 469, 1909.
Journ. of Soc. of Architects, Jan. 1910.
- WEBER, L. Units of Light and Brightness. The Electrician, vol. xxv.
p. 404, 1890.
- WHITMAN, F. P. Flicker Photometer. Physical Review, vol. iii. p. 241,
1896. (D. 1, 893.)
Science, vol. viii. p. 11, 1898. (C. 2, 883.)
- WIENER, C. Diffusion of Light from Dull Surfaces. The Electrician, vol.
xxxiii. pp. 549 and 621, 1894.
- WILD, L. Some Causes of Error in Photometry. The Electrician, vol. lvii.
p. 559, etc., 1908.
Flicker Photometer. Ill. Eng. Lond. vol. i. p. 825, 1908.
Mirror Photometer. Ill. Eng. Lond. vol. iii. p. 30, 1910.

INDEX

- Abney, Sir W. de W., rotating sectors, 129
 method of photometry, 164
 Purkinje effect, 166
 peripheral region of retina, 169
 luminosity of spectrum, 171-173
- Accuracy, Rumford, 78, 80
 Kennelly and Whiting, 119
 errors and mistakes, 183-198
- Albedo, 25, 244
- Amyl-acetate lamp. *See* Hefner
- Angle errors of photometers, 95
 of illumination photometers, 217-223, 241
- Angle of Ritchie wedge, 91-95
- Arc, Swinburne-Thompson standard, 12
 distribution of light from, on plane, 33,
 155, 172-181
 polar curve of candle-power, 146-148
 mean spherical candle-power, 149-160
- Average illumination of a street, 53-58
- Ayrton, Mrs., rotation of arc, 13
 Rousseau's diagram, 151-153
- Bases of comparison of illuminated areas, 52-
 64, 262
- Battery, constancy of, 226, 227
- Bar, photometer, construction of, 125, 127
- Black paints, 138
- Bloch, L., on horizontal measurements, 230
- Blondel, A., arc standard, 12
 mean-spherical candle-power, 21
 photometric units and definitions, 21
 lumen, 22
 lumenometer, 154
 photometer, 243
 holophane, 272
- Bougie-décimale, 8, 9
- Bougie-metre, 17
- Bougie-metre-second, 24
- Bouguer, P., on photometry, 63
 photometer, 74-77
 colour photometry, 163
- Brightness, 23, 93
 instruments for measuring, 244
- Brilliance, intrinsic, 23
- Broca, 194, 195
 photometer, 243
- Bunsen's photometer, 83-87, 192, 193, 200
- Candle, British Parliamentary, 4, 8
 German, 4
- Candle-foot. *See* Foot-candle
- Candle-power, definition, 2
 measured in the street, 225, 226
 mean horizontal 140-146
 mean spherical, 140, 149-160
- Carcel, 3
- Celsius, 70
- Characteristic curves, 58-64, 262
- Colour of lights and watts per candle, 161,
 193
- Colour photometry, 161-182
 Macé de Lépinay, 162
 Helmholtz on, 163
 Bouguer, 163
 Abney's method, 164
 Dow, 167
 Crova's method, 170-174
 Koening, 173
 Nichols, 173
 flicker photometer, 174-181
- Colour vision, 166, 168
- Coloured screens, red and green, 162
 Crova, 171
 stained gelatin, 174
 Cooper's method, 182
 Wratten and Wainwright, 182
 for illumination photometer, 212, 232
- Comparison of cases of illumination, 52, 262
- Compensation or double weighing method,
 115-120
- Conroy, Sir J., 97, 170
- Cosine or Lambert's law, 19, 20, 217, 221,
 223
- Cosines cubed, curve of, 28, 36, 54, 264
 tables of, 275-277
- Dach photometer, 106
- Daylight photometry, 246-249

- Degradand, L. O., 271, 273
 Dibdin, W. J., 4, 7
 Diffused reflection, 24, 158, 220
 Dioptric distribution and diffusion, 263-274
 profiles of prisms, 266, 267, 272
 lantern, 267
 shades, 268, 272, 273
 Discrimination photometers, 27-64
 Distribution of light from glow-lamps, 145
 from arc-lamps, 146
 by dioptric shade, 271
 Dow, J. S., colour photometry, 167
 flicker photometry, 178, 181
 lumeter, 244
 Draper, 8
 Dyke, G. B., mean spherical candle-power, 153
 arrangement of mirrors, 156
- Electric lamp sub-standards, 138
 Errors, 183-198
 mean, of result, 185, 188
 mean, of single observation, 186, 188
 probable error, 187
 personal error, 189-196
 fatigue, 190-192
 speed of working, 86, 192
 illumination, 194
 instrumental, 196
 Everett-Edgecombe, bar and carriage, 126
 illumination photometer, 212
 luxometer, 245
 Exposure, photographic, 24, 69
- Fechner-Weber law, 28
 Flame standards, corrections for, 9
 Fleming, Dr. J. A., "pyr," 2
 sub-standard glow-lamps, 14
 discrimination photometer, 72
 compensation or double weighing method,
 117, 119
 deviation from law of inverse squares, 122
 Flicker photometer, 174-181
 Whitman, 174
 Rood, 175
 Simmance-Abady, 175
 Wild, 177, 180
 Dow, 178
 illumination of, 178
 speed of, 179-181
 Flux of light, 21, 53-56
 Foot-candle, definition of, 15
 table of equivalents, 278
 Foucault's photometer, 80
 Fovea, 168
 Fowler, H., 110
 Fredureau, 271
- Globe, Ulbricht's, 157-160
 Glow-lamps, distribution of light from, 145
- Goniometer, refraction, 280
 Gradient of illumination, 120
 Grid photometer, 109
- Haldane, Dr. J. S., 10
 Harcourt, Prof. V., lamp, 4
 photometer, 81
 Harrison, Haydn T., illumination photometry,
 229, 232, 234-236
 Hefner lamp, description of, 5
 unit, value of, 9
 colour of, 161
 Height, effect of varying, 37-40
 and spacing of lamps, 38-44
 of illumination photometers, 227-229
 Holophane shades and reflectors, 272
 Horizontal plane, measurement of illumination
 on, 230
 Houston and Kennelly's photometer, 70
 Hyde, Dr. E. P., comparison of units, 9
 flux per area, 53
 deviation from law of inverse squares, 122
 Talbot's law, 129
 white walls, 134
 mean horizontal candle-power, 144
- Illumination, definition of, 15
 relation of units, 17
 quantity of, 23
 distribution of, 27-64
 curves, 47-51
 measurements, 199-262
 photometers, 200-248
 practical examples of measurements, 250-
 261
 Instrumental errors, 184, 196
 International unit of candle-power, 9
 Intrinsic brilliancy, 23
 Iris diaphragm photometers, 243
 Iso-lux curves, 47-51
 Ives, H. E., 182
- Jevons, on errors, 187
 Joly, photometer, 110
- Kelvin, on light, 69
 Kennelly and Houston, 71
 Kennelly and Whiting, 119, 177
 Korting and Mathieson, 273
- Lambert, cosine law, 19, 20, 217
 albedo, 25
 on photometry, 66
 Leeson disc, 87
 Leonard, 157
 Leonardo da Vinci, 74
 Liebethal, 5, 6
 Light defined, 2, 69
 Lumen, 22, 150, 154

- Lumen-hour, 24
 Lumenmeter (Blondel), 154
 Lumeter (Dow and Mackinney), 244
 Lummer-Brodhun photometer, 99
 Lummer and Kurlbaum, 13
 Lux, 17, 18
- M'Dougall, W., 169, 179
Macula lutea, 168
 Marten's photometer, 242
 Matthew's mirrors, 154
 Maxima and minima of illumination, 30-32,
 53, 64
 Mean error of a single observation, 186, 188
 of the result, 188
 Mean horizontal candle-power, 140-145
 Mean illumination of a street, 53, 57, 61, 63
 Mean spherical candle-power defined, 20
 practical value of, 140, 149, 150
 calculation of, 151-160
 Blondel on, 21, 154
 Rousseau's diagram, 150
 Russell's diagram, 152
 Dyke on, 153, 155
 Matthew's method, 154
 Wild's method, 157
 Ulbricht's method, 157
- Meterkerze, 16, 17
 Metre-candle, 17
 Millar, P. S., criticisms, 204, 206
 Sharp-Millar photometer, 239
 Milne, J. R., 130
 Minima of illumination calculated, 30-32, 41,
 53, 62, 64
 measured, 204, 207, 209, 214
 Mirrors, Wild's arrangement, 102, 144, 157
 moving, method, 123
 to reduce flicker, 145
 Blondel's arrangement, 154
 Matthews' arrangement, 154
 Dyke's arrangement, 155
 Leonard's arrangement, 157
- Mistakes distinguished from errors, 184
 Monasch, Dr. B., 17
 Moonlight, illumination by, 259
 Morris, J. T., 180
- Observation recorder, 132
- Paints, dead black, 138
 Paterson, C. C., carcel, 4
 Hefner, 17
 Pentane corrections, 11
 illumination of photometer, 119
 watts per candle and colour, 161
 Peard, reflecting shade, 274
 Pentane lamp described, 4
 relative value of, 8, 9
 corrections for, 10
- Pentane lamp, colour of, 161
 Perforated screen, 102-106, 214
 Personal errors, flicker, 180
 distinguished from instrumental, 184
 sources of, 189-196
 Petavel, J. E., 8, 13
 Peter's formula for errors, 187
 Photographic photometry, 69
 Photometers, 65, 74
 Blondel, 243
 Bouguer, 65, 74
 Broca, 243
 Bunsen, 83-87, 192, 193, 200
 Conroy, 97, 170
 Dach, 106
 Dow and Mackinney, 244
 Everett Edgcombe, 245, 248
 Fleming, 72
 Flicker, 174-181
 Foucault, 80
 Gas Referees', 81
 Grid, 109
 Harcourt, 81
 Harrison, 234-236
 Joly, 110
 Krüss, 242
 Lummer-Brodhun, 99
 Marten's, 242
 Perforated screen, 102-106, 214
 Preece, 200
 Preece-Trotter, 202
 Ritchie, 87-97, 164
 Rood, 175
 Rumford, 77-80
 Sharp-Millar, 239
 Simmance-Abady, 175, 242
 Swan, Sir J., 100
 Thompson-Starling, 98
 Trezise, 244-246
 Trotter, 203
 Weber, L., 106, 237
 Whitman, 174
 Wild, L., 102, 144
 Wingen-Krüß, 242
- Photometry defined, 63
 Photoped, 82
 Polimanti, 178
 Porter, T. C., on flicker, 178
 Potentiometer, 139
 Precision, 183, 197
 Preece, Sir W. H., lux, 17
 measurement of illumination, 200, 224,
 250-257
 photometer, 201
 Psaroudaki, 272
 Purkinje, 166
 Pyr, proposed unit, 2
- Quantity of light, 23

- Radiation standards, 13
 Recording instrument, 132
 Reduction factor, 153
 Reflection, diffused, 24
 from bulbs, 142
 uniform distribution of illumination by, 265
 Refraction, instrument for calculating, 280
 diagram for calculating, 282
 Ritchie photometer, 87-97, 164
 Rood photometer, 175
 Rotating lamps, 117, 143, 177
 sectors, 127-130
 Rousseau's diagram, 150
 Rumford, Count of, 77-80
 Russell's diagram, 152
- Scales for photometer bar, 112-127, 279
 Screens, coloured. *See* coloured screens
 for photometers, 93, 94
 for stray light, 134-138
 for illumination photometers, 216, 220-223
 Sectors, rotating, 127-130
 Sharp and Millar's photometer, 239-241
 Simmance and Abady flicker photometer, 175, 181
 illumination photometer, 243
 Slot or limit-gauge photometer, 106
 Smith, Roger T., illumination photometry, 229, 231
 Spacing of lamps, 38-44, 62
 Speed of working in Photometry, 86, 192
 flicker photometers, 179-181
 Spherical candle-power. *See* Mean spherical
 Squares, the law of, 17
 departure from the law of, 121
 Standards distinguished from units, 3
 relative values of, 8
 Sumner, Dr. W. E., 25, 160
- Talbot, 128
 Theatre lighting, 261
 Thompson, Sir Benjamin. *See* Rumford
 Thompson, S. P., arc standard, 12
 photometer, 98
 method, 165
 Trezise, J. M. G., 246
- Ulbricht's globe, 157-160
 Units distinguished from standards, 3
- Varying height, effect of, 37
 Vereinskerze, 4
 Vertical filament, 34
 Vertical plane, 35, 232
 Violle, 7
- Waldram, P. J., 248
 Weber-Fechner law, 28
 Weber, L., Dach photometer, 106
 colour photometry, 162
 portable photometer, 236-238
 Whitehall, photometric survey of, 257-260
 Whitman's photometer, 174
 Wild, L., Bunsen disc, 87
 mirror photometer, 102
 mean horizontal candle-power, 144
 mean spherical candle-power, 157
 flicker photometer, 180
 Wimbledon, early photometric measurements
 at, 250, 270, 271
 Wingen-Krüß photometer, 241
 Wybauw, polar curve of arc-lamps, 147
 illumination on horizontal plane, 230
- Zöllner, 26

THIS BOOK IS DUE ON THE LAST DATE
STAMPED BELOW

AN INITIAL FINE OF 25 CENTS
WILL BE ASSESSED FOR FAILURE TO RETURN
THIS BOOK ON THE DATE DUE. THE PENALTY
WILL INCREASE TO 50 CENTS ON THE FOURTH
DAY AND TO \$1.00 ON THE SEVENTH DAY
OVERDUE.

SEP 11 1935

MAY 17 1936

MAR 9 1936

FEB 27 1939

NOV 8 1940 M

OCT 13 1941 M

APR 25 1945

9 AP'53 M

APR 3 1953 LU

10 Sep'50 Lr

AUG 27 1953 LU

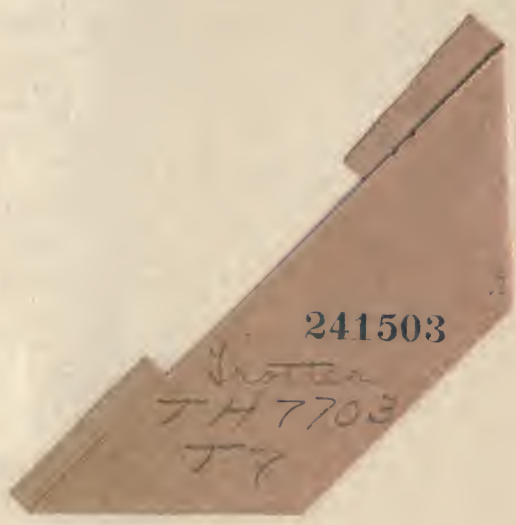

241503

Letter
747703
77

