

SIGILLVM · VNIVERSITATIS · CALIFORNENSIS

EX · LIBRIS

536
2474

INDUSTRIAL CHEMISTRY



THE MACMILLAN COMPANY

NEW YORK · BOSTON · CHICAGO · DALLAS
ATLANTA · SAN FRANCISCO

MACMILLAN & CO., LIMITED

LONDON · BOMBAY · CALCUTTA
MELBOURNE

THE MACMILLAN CO. OF CANADA, LTD.

TORONTO

INDUSTRIAL CHEMISTRY

FOR

ENGINEERING STUDENTS

BY

HENRY K. BENSON, PH. D.

PROFESSOR OF INDUSTRIAL CHEMISTRY IN THE UNIVERSITY
OF WASHINGTON

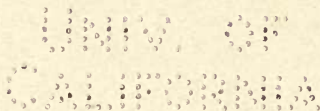

New York

THE MACMILLAN COMPANY

1913

All rights reserved

TP145
B4

COPYRIGHT, 1913,
By THE MACMILLAN COMPANY
Set up and electrotyped. Published December, 1913.

TO THE
AUTHOR

PREFACE

THE purpose of this text is to describe from the standpoint of chemistry, the more common materials used in the various branches of engineering. Emphasis is accordingly laid upon the occurrence, the mode of manufacture, the properties, and, to a limited extent, the uses of the various materials. The text is an elaboration of the author's lecture notes used during the last eight years in the courses of industrial chemistry for second year engineering students. The compilations of data have been taken from various sources, many of which are indicated in the footnotes.

The work presupposes a knowledge of elementary physics and general chemistry. By a selection of suitable subject matter, it is hoped to give the prospective engineer a working knowledge of the chemistry of the materials and processes with which he will deal and the ability necessary to interpret chemical analyses and apply them in the preparation of specifications and in the pursuit of experimental research which now so frequently accompanies the solution of engineering problems. The topics of greatest interest and importance to engineers, such as fuels and combustion, clay products and cement, are treated quite fully; other topics are necessarily dealt with more briefly than in the larger text-books but in all cases the bibliographies at the ends of the chapters will guide the reader who desires to go farther. These bibliographies have been compiled with care and brought closely down to date; it is believed that they will be useful to practicing chemists and engineers as well as to students. In these bibliographies, books are first listed alphabetically by authors,

then follow titles of journal articles, etc., in chronological order.

The author has endeavored to make each chapter sufficiently complete in itself and the index of the book sufficiently full so that (if the index be used) the topics may be taken up in a different order than that of the book if the teacher prefers. Some teachers will probably prefer to use the first chapter on general processes and apparatus chiefly for reference and to begin class study with Chapter II.

The writer takes pleasure in acknowledging his indebtedness to his colleagues, Professors H. G. Byers for helpful advice and suggestions, and J. M. Johanson for assistance in the critical examination of the manuscript. Acknowledgment is made also to Mr. Henry B. Allen, Metallurgical Engineer, Examiner of Iron and Steel Products in the U. S. Customs Service, Professor Charles F. Binns, Director of the New York State School of Ceramics and Clay Working, Dr. Otto Kress, Instructor in Engineering Chemistry in Columbia University, and Mr. Walton Van Winkle of the Water Resources Branch of the U. S. Geological Survey, for revision of the manuscript as a whole or of those parts relating to their respective specialties.

It is desired also to express here appreciation of the kindness of numerous manufacturers in furnishing cuts and drawings used to illustrate the text.

H. K. B.

June, 1913.

CONTENTS

| CHAPTER | PAGE |
|--|------|
| I. GENERAL PROCESSES AND APPARATUS..... | 3 |
| Transportation of materials..... | 3 |
| Grinding and mixing..... | 12 |
| Calcination and fusion..... | 21 |
| Evaporation and distillation..... | 23 |
| Filtration and separation..... | 30 |
| Drying appliances..... | 33 |
| References..... | 37 |
| II. THE ATMOSPHERE..... | 38 |
| Composition and sanitary properties of air..... | 39 |
| Mine air..... | 46 |
| Ventilation..... | 46 |
| Air as a heating and drying agent..... | 50 |
| Refrigeration..... | 52 |
| Utilization of atmospheric nitrogen..... | 54 |
| References..... | 59 |
| III. INDUSTRIAL WATER..... | 61 |
| Sanitary aspects of water supply..... | 61 |
| Water for steam generation..... | 65 |
| Scale formation..... | 66 |
| Water softening..... | 68 |
| Corrosion..... | 70 |
| Foaming and priming..... | 72 |
| Standards of purity..... | 74 |
| Water for use in irrigation..... | 76 |
| References..... | 77 |
| IV. COMBUSTION AND DESTRUCTIVE DISTILLATION..... | 81 |
| Combustion..... | 81 |
| Determination of calorific power..... | 84 |
| The elements of combustion..... | 86 |

| CHAPTER | PAGE |
|---|---------|
| Combustion— <i>Continued</i> | |
| Efficiency of combustion | 88 |
| Prevention of smoke | 91 |
| Spontaneous combustion | 92 |
| Destructive distillation | 92 |
| Wood distillation | 93 |
| Distillation of coal | 99 |
| Beehive oven | 101 |
| By-product oven | 101 |
| References | 109 |
| V. SOLID FUELS | 113 |
| Classification | 113 |
| Natural solid fuels | 113 |
| Classification of coal | 119 |
| Artificial solid fuels | 130 |
| Minor solid fuels | 133 |
| References | 134 |
| VI. LIQUID AND GASEOUS FUELS | 137 |
| Liquid fuels | 137 |
| Petroleum oil | 137 |
| Shale oil and tar | 142 |
| Gaseous fuels | 143 |
| Natural gas | 144 |
| Coal gas | 148 |
| Coke oven gas | 148 |
| Water gas | 149 |
| Producer gas | 151 |
| Blast furnace gas | 151 |
| Acetylene | 155 |
| Gases from the vaporization of liquids | 158 |
| References | 164 |
| VII. PETROLEUM AND LUBRICATING OILS | 167 |
| Petroleum | 167 |
| Lubricating oils | 175 |
| Solid lubricants | 183 |
| References | 186 |

CONTENTS

ix

| CHAPTER | PAGE |
|--|------|
| VIII. THE MANUFACTURE OF PIG IRON..... | 189 |
| Iron ores..... | 189 |
| Smelting..... | 191 |
| Chemical reactions of the blast furnace..... | 196 |
| Blast furnace gas..... | 199 |
| Blast furnace slag..... | 200 |
| Classification of pig iron..... | 202 |
| References..... | 203 |
| IX. COMMERCIAL FORMS OF IRON AND STEEL..... | 205 |
| Cast iron..... | 205 |
| Wrought iron..... | 208 |
| Steel..... | 211 |
| Cementation steel..... | 211 |
| Crucible steel..... | 213 |
| Bessemer steel..... | 214 |
| Open hearth steel..... | 218 |
| References..... | 224 |
| X. THE INDUSTRIAL ALLOYS..... | 225 |
| Definition of term alloy..... | 225 |
| Iron alloys..... | 226 |
| The special steels..... | 229 |
| Bronze..... | 231 |
| Brass..... | 231 |
| Bearing metals..... | 232 |
| Miscellaneous alloys..... | 233 |
| References..... | 233 |
| XI. CLAY PRODUCTS..... | 235 |
| Nature and origin of clay..... | 235 |
| Classification of clays..... | 237 |
| Physical properties of clay..... | 248 |
| Chemical properties of clay..... | 252 |
| Uses of clay..... | 257 |
| Building brick..... | 257 |
| Fire brick..... | 262 |
| Paving brick..... | 263 |
| Tiles..... | 266 |
| Earthenware..... | 268 |
| Porcelain..... | 269 |
| References..... | 270 |

| CHAPTER | PAGE |
|--|----------------|
| XII. HYDRAULIC CEMENTS AND LIME PRODUCTS..... | 273 |
| Classification..... | 273 |
| Hydraulic cements..... | 274 |
| Portland cement..... | 274 |
| Natural cement..... | 288 |
| Hydraulic lime..... | 294 |
| Puzzolan cement..... | 295 |
| Lime and gypsum products..... | 297 |
| Hydrated lime..... | 298 |
| Sand lime brick..... | 304 |
| Stucco and plasters..... | 307 |
| Hydraulic gypsum..... | 308 |
| References..... | 310 |
| XIII. PAVING MATERIALS AND WOOD PRESERVATION..... | 313 |
| Classification of road binders..... | 313 |
| Chemically treated wood blocks..... | 314 |
| Road binders..... | 321 |
| Properties of asphalt..... | 325 |
| Coal tar as road material..... | 328 |
| References..... | 329 |
| XIV. PAINT AND VARNISH MATERIALS..... | 331 |
| Classification..... | 331 |
| Pigments..... | 332 |
| Vehicles..... | 339 |
| Driers..... | 348 |
| Varnish materials..... | 350 |
| Bituminous paints..... | 353 |
| Paints for special uses..... | 354 |
| References..... | 362 |
| XV. PLASTICS FOR ELECTRICAL INSULATION..... | 366 |
| Insulation..... | 366 |
| Classification of insulating materials..... | 367 |
| High temperature insulators..... | 368 |
| Low temperature insulators..... | 370 |
| Mixtures and compositions..... | 375 |
| References..... | 378 |

CONTENTS

xi

| CHAPTER | PAGE |
|---|------|
| XVI. CELLULOSE PRODUCTS..... | 380 |
| Nature and properties of cellulose..... | 380 |
| The use of cellulose in the manufacture of paper..... | 382 |
| Pyroxylin compositions..... | 389 |
| Viscose preparations..... | 392 |
| Artificial filaments..... | 393 |
| Ethyl alcohol from sawdust..... | 395 |
| References..... | 397 |
| XVII. EXPLOSIVE MATERIALS..... | 399 |
| Nature of explosive reactions..... | 399 |
| Classification of explosive materials..... | 401 |
| Explosive mixtures..... | 401 |
| Explosive compounds..... | 404 |
| Adaptation of explosives to industrial and engineering operations..... | 415 |
| References..... | 419 |



LIST OF ILLUSTRATIONS

| FIG. | PAGE |
|---|------|
| 1. Steam jet blower. | 4 |
| 2. Lead lined acid fan. | 5 |
| 3. Four-stage air compressor with steam engine. | 6 |
| 4. Air jet lift. | 8 |
| 5. Centrifugal pump. | 10 |
| 6. Bucket elevator. | 11 |
| 7. Belt conveyer. | 11 |
| 8. An air separator installation. | 12 |
| 9. Stamp mill. | 13 |
| 10. Ball mill. | 14 |
| 11. Tube mill. | 15 |
| 12. Griffin mill, general view. | 16 |
| 13. Griffin mill, section. | 17 |
| 14. Clay disintegrator; A. Front View, B. Rear View. | 18 |
| 15. Dry pan. | 19 |
| 16. Stone mill. | 20 |
| 17. Siemen's regenerative furnace. | 22 |
| 18. Yaryan evaporator (cross section). | 23 |
| 19. Yaryan evaporator (end view of quadruple effect). | 24 |
| 20. Zarembo triple effect evaporator. | 26 |
| 21. Kestner climbing film evaporator. | 27 |
| 22. Continuous column still. | 29 |
| 23. Filtration of crude oil. | 30 |
| 24. Centrifugal filter. | 31 |
| 25. Bowl of centrifugal filter. | 32 |
| 26. Hydraulic press. | 34 |
| 27. Rotary drier (longitudinal cross section) | 36 |
| 28. Hygrometric chart | 43 |
| 29. Plan of air purifier. | 49 |
| 30. Swedish coke oven. | 94 |
| 31. Bee hive coke oven. | 100 |
| 32. Semet Solvay coke oven. | 102 |
| 33. Chart illustrating the relative increase of by-product coke ovens | 108 |
| 34. Yearly production of anthracite and bituminous coal. | 127 |

| FIG. | PAGE |
|--|------|
| 35. A commercial burner for fuel oil | 139 |
| 36. Mixing mechanism of fuel oil burner | 139 |
| 37. The blast furnace | 193 |
| 38. Stove for heating the air used in blast furnaces | 195 |
| 39. Cupola furnace for melting pig iron | 206 |
| 40. Puddling furnace | 208 |
| 41. The Bessemer converter | 215 |
| 42. Open hearth furnace | 219 |
| 43. Double shaft pug mill | 258 |
| 44. Auger brick machine | 259 |
| 45. Down draft brick kiln | 260 |
| 46. Diagram showing the sequence of steps in the manufacture of Portland cement from clay and limestone | 277 |
| 47. Rotary kiln for producing cement clinker | 279 |
| 48. Modern lime kiln, showing means employed for an induced draft and discharging lime through a cooling dome | 299 |
| 49. Kritzer lime hydrator | 300 |
| 50. Kritzer lime hydrator (sectional view) | 301 |
| 51. Pressure cylinder for sand lime brick | 306 |
| 52. Diagram of an experimental tank used for treating fence posts . | 320 |

INDUSTRIAL CHEMISTRY

UNIV. OF
CALIFORNIA

CHAPTER I

GENERAL PROCESSES AND APPARATUS

THE application of chemical processes to the manufacture of industrial and technical products has developed various forms of apparatus which enter largely into the economy and practicability of these processes. While the field thus to be considered is very wide and embraces a great variety of special forms, it nevertheless will simplify the discussions which follow to outline briefly the general processes and the means employed to carry them on. This may be done most readily, perhaps, by considering the operations with which the student is familiar in the laboratory as they become modified or changed in large scale operations.

The following classification of processes is proposed:

- I. Transportation of materials.
 1. Gases.
 2. Liquids.
 3. Solids.
- II. Grinding and mixing.
- III. Calcination and fusion.
- IV. Evaporation and distillation.
- V. Filtration and separation.
- VI. Drying appliances.

I. TRANSPORTATION OF MATERIALS

The selection of a proper conveying apparatus is conditioned by the character of the material, whether dry or moist, viscous or limpid, free from liability to evaporate or gasify,

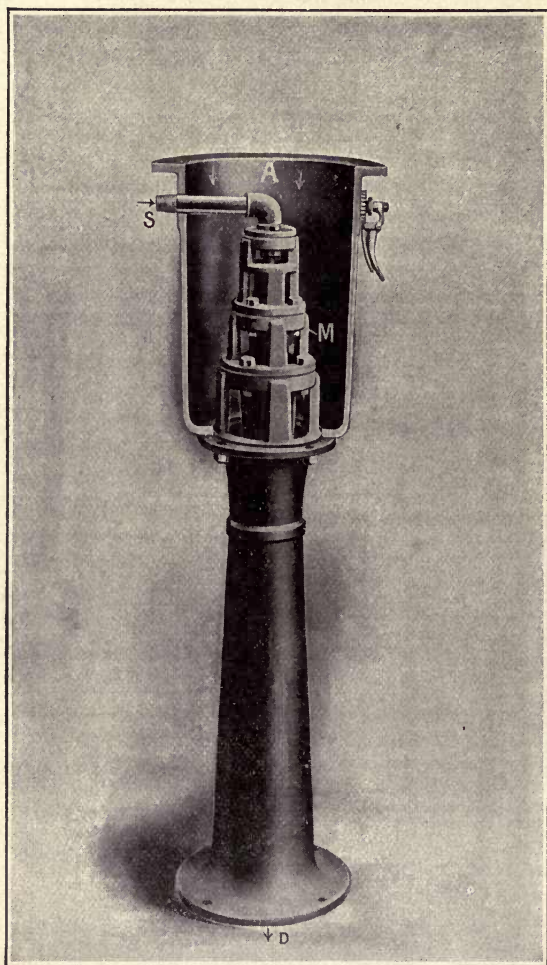

FIG. 1. Steam Jet Blower.

inert or corrosive, etc. Typical forms only can therefore be described in a brief discussion.

1. Transportation of Gases.—The appliances used in moving or conveying gases from one point to another may consist of the *steam jet blower*, *fan blower*, *air compressor*, or *vacuum pump*. In certain processes obnoxious gases are also removed by means of *chimney draft*, as in ventilation and in

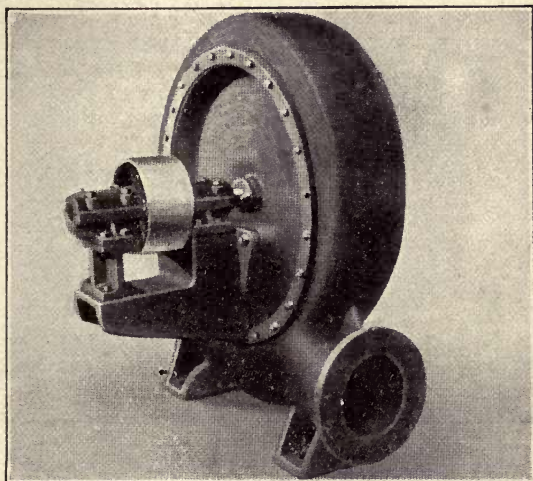

FIG. 2. Lead Lined Acid Fan.

producing the draft necessary for carrying away the products of combustion.

The *steam jet blower* (Fig. 1) can be used only where the admixture of steam to the gases to be moved is not objectionable. The blower may act either as a blower proper for introducing a mixture of air and steam into a gas producer, etc., or more frequently as an exhauster to produce rarefaction of pressure and thereby increase the velocity of a column of moving air, as when applied to chimneys, ventilating flues, etc. The principle governing the construction of jet appara-

tus is the mechanical effect of a gaseous current (of steam) in agitating and setting in motion the surrounding medium or atmosphere. Steam enters at *S*, passes through the nozzles, *M*, and is discharged at *D*, while air is sucked in at *A*.

The *fan blower* is used for handling large volumes of gas at a moderate velocity and with a minimum expenditure of power. Blowers of this type may be employed either for the introduction of gases or as exhausters. Their efficiency

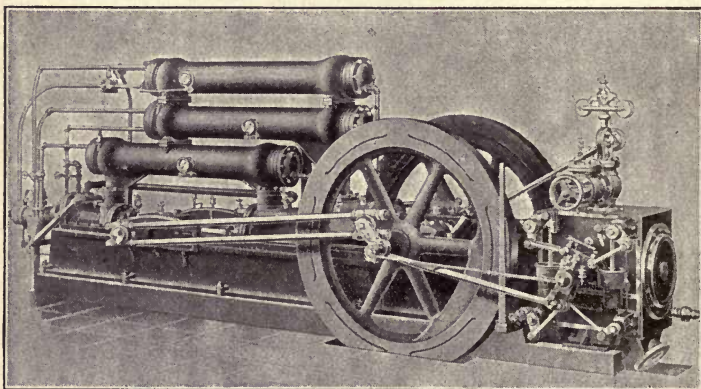

FIG. 3. Four Stage Air Compressor.

depends upon the details of construction, such as the form of the blast wheels, relation of inlet to outlet, etc. When gases of an acid or corrosive character are transported the steel plates are lead lined (Fig. 2). Earthenware may also be used.

For conveying gases at a higher pressure than that of the atmosphere the *air compressor* is generally employed. In its construction it differs from an ordinary air pump in that its mechanism provides for the cooling of the piston and valves by water circulation or air cooling (Fig. 3). For many operations the compressor gives way to the *vacuum pump*, as in the evaporation of liquids and in driers. The vacuum pump differs from an ordinary compressor only in the fact

that it does work equivalent to that required in taking a gas at 28 inches of vacuum and delivering it at atmospheric pressure.

Chimneys serve the purpose of removing obnoxious gases and creating a draft in the combustion of fuels. Size is the essential factor in the former operation and height in the latter. The quantity of gas capable of being carried away by a chimney depends upon the velocity and density of the gas and the size of the chimney. Since the velocity increases and the density decreases with a rise in temperature, it follows that there must be a temperature at which the weight of gas delivered is a maximum. Most chimney calculations, however, are based on a temperature of 600° F., a considerable variation of temperature having but slight effect (less than 4 per cent) in the quantity of gas delivered.

The intensity of draft is dependent, however, on the difference in weight between the outside and inside columns of air. Various computations to find the draft of a given chimney in the usual units (inches of water), or to find the height of a chimney necessary to give a specific draft power, are given in the engineering texts¹ and treatises² dealing with this problem.

2. Transportation of Liquids.—The appliances used in the transportation of liquids are quite numerous, consisting of such forms as *injectors*, *syphons*, *eductors*, *montejus*, *air jet lifts* and *pumps*. Of these the *injector* is perhaps best known in connection with the feed water supply of boilers and needs no further explanation. For the moving of chemicals in solution, however, some care must be exercised in the proper selection of the materials used in the construction of the appliance, which may be made of iron, steel, copper, lead, bronze, stoneware, or hard rubber.

¹ Carpenter: Heating and Ventilating Buildings, p. 191.

² Nagel: Mechanical Appliances of the Chemical and Metallurgical Industries, p. 124.

The syphon operated by the steam jet above described is often used in industries where large quantities of liquid are transferred from tank to tank, as in the manufacture of paper pulp, leather, sugar, etc.

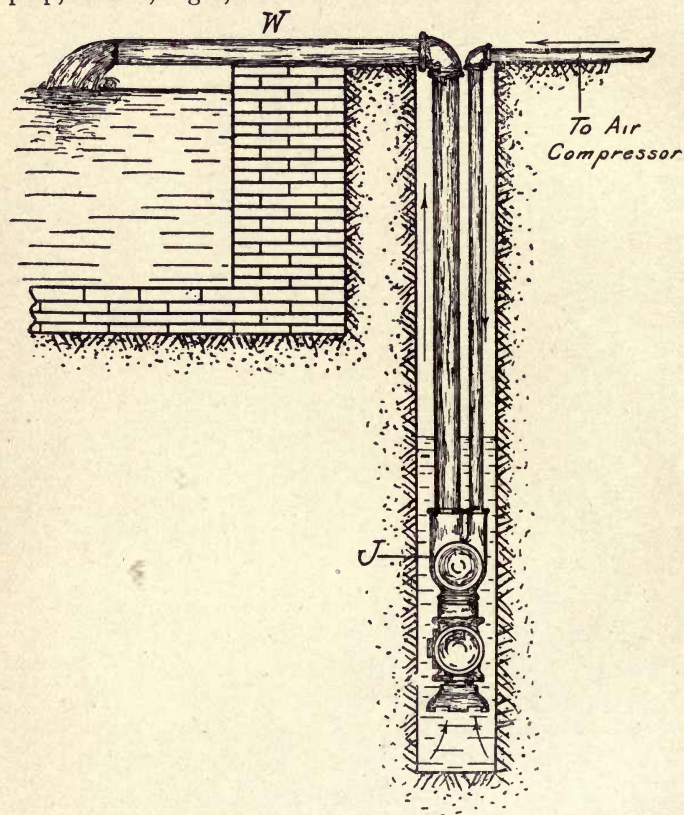

FIG. 4. Air Jet Lift.

For the lifting of water or oil from wells the *air jet lift* (Fig. 4) has been successfully used. In the operation of the air jet lift, air (*A*) is pressed into the lower end of a submerged pipe and mixed with the liquid (*J*) inside the air jet lift. The

mixture, because of its lighter weight, is therefore forced upwards, giving a continuous discharge (W) of liquid. The quantity of the latter is easily regulated by regulating the quantity of compressed air. Since the air jet lift is stationary and has no movable parts it may be readily constructed of hard rubber or stoneware and is therefore especially desirable for use in acid plants and chemical works. Compressed air as a motive power for lifting liquids is used also in *montejus* or so-called acid eggs, which are constructed of cast iron, lead lined iron, or copper. They are built on the principle which utilizes the buoyancy and weight of a float respectively to open and close the valve, admitting the compressed air.

Instead of steam or compressed air, water may be used in the operation of jets or *eductors* which are of a construction similar to that of the jet blowers. In an apparatus of this type water under a high pressure is made to pass with great velocity through the apparatus thus creating a vacuum and causing the liquid to be elevated to enter the discharge pipe. Obviously this form of apparatus, if used for solutions, would cause great dilution and is therefore of very limited application. It finds its chief uses in draining cellars, mines, filter beds and in general where high pressure water is more economical for use than steam or compressed air.

Many types of *pumps* are in use, driven by steam, compressed air, electricity, gas engines or water turbines. A pump in general use in chemical industries is the centrifugal pump (Fig. 5), which may be constructed either as the volute or the turbine type. In the former the water, after its discharge from the impelling blades, enters a volute or specially shaped discharging chamber to reduce its velocity; while in the turbine type, diffusion or guide vanes are made to serve this purpose.

3. Transportation of Solids.—To convey solids a very large variety of appliances are in use, of which only the more common types can be briefly described in this treatise. For

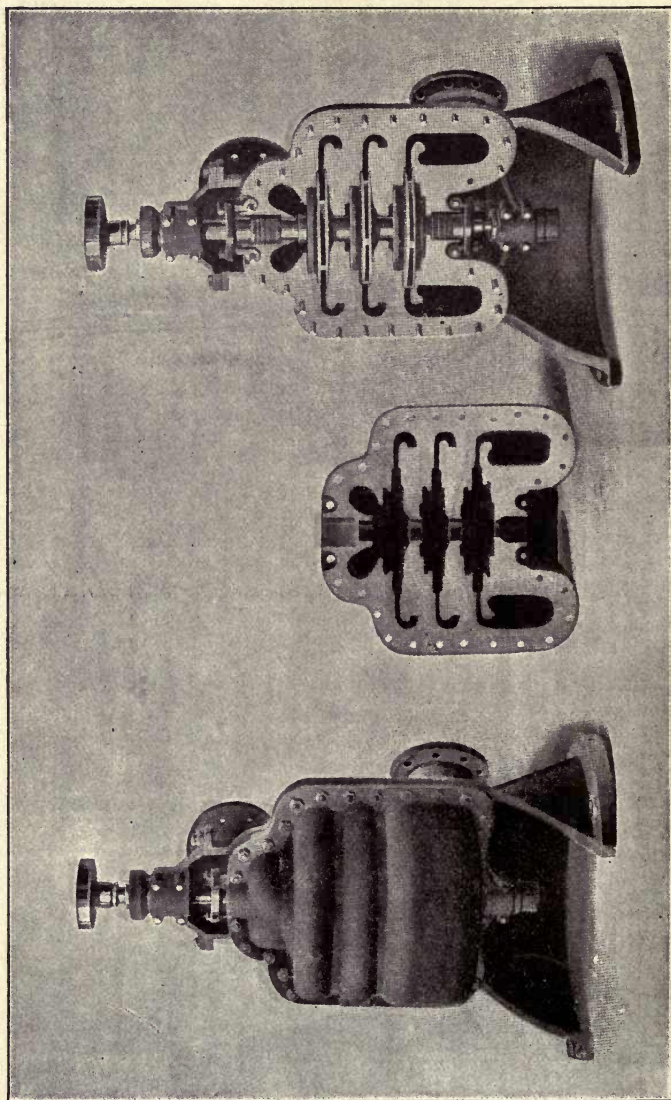

FIG. 5. Centrifugal Pump.

dry materials, such as rock and cement powders, *bucket elevators* (Fig. 6) are frequently employed. These consist of cast iron or steel troughs mounted at intervals in chains or on belts, each bucket delivering its contents after passing over the head wheel. *Screw conveyors* consist of a central shaft, with spiral plates mounted in iron or steel troughs, the material being transported by the spiral action of the blades. Carrying conveyors consist usually of three types, known as apron, bucket, and belt conveyors, and are used mostly for horizontal or oblique transportation. The apron conveyors consist of either plain or corrugated steel plates secured to two strands of chain supported by self-lubricating rollers; bucket conveyors

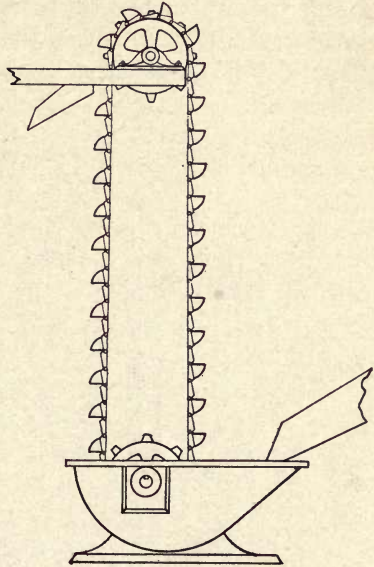

FIG. 6. Bucket Elevator.

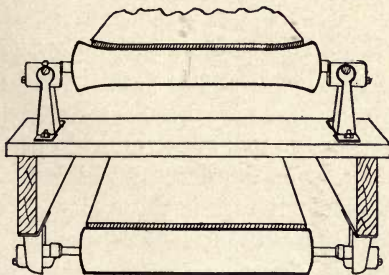

FIG. 7. Supports for Belt Conveyor.

are similar to bucket elevators; while belt conveyors consist of a continuous belt supported at intervals by rollers both on the carrying and idle run (Fig. 7). The rollers are sometimes plain cylinders, but more frequently those placed

in the carrying run are troughed so as to increase the carrying capacity. Solids in a fine dry state of division are also transported by fan blowers as in the Raymond system of air separation (Fig. 8) and in the fuel feed systems such as pulverized coal in cement mills or where sawdust constitutes

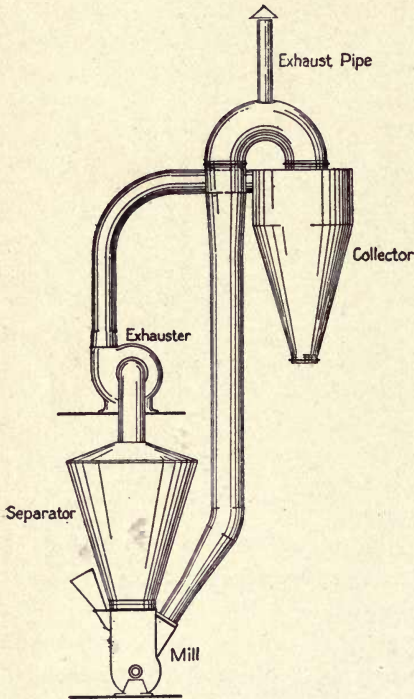

FIG. 8. Air Separator.

the bulk of the fuel as in sawmills. The vacuum created by the steam jet (Fig. 1) is also sometimes utilized in the handling of dust and poisonous solid materials in powder form.

II. GRINDING AND MIXING

For the grinding and mixing of raw materials and finished products a large number of appliances are available. The factors governing the selection are largely the nature of the substance to be reduced

as to hardness, dryness, fineness, as well as the desired character of the finished product. For the purpose of keeping in mind the especial types commonly used in the preparation of the products described in this text special attention will be given to the appliances used in the rock products, ceramic and paint industries.

The grinding and mixing appliances which find large application in the rock products industry may be roughly classified as crushing and pulverizing machines. In the former operation may be used the *jaw crusher* which utilizes the pressing force of a moving jaw; crushing rolls, which make use of the pressing force of revolving fixed cylinders; and the *gyratory crusher* which employs a crushing head mounted upon a vertical spindle, the bottom of which passes loosely through an eccentric driven from a horizontal shaft by bevel gears, giving a gyratory motion to the crushing part of the mechanism.

Stamp mills (Fig. 9) are also employed especially in the mining industry. In pulverizing rock powders ball mills, tube mills and Griffin or Fuller mills are quite generally employed. A *ball mill* (Fig. 10) consists of a short drum, revolving on a shaft, partially filled with steel balls. The lining of the drum is made up of curved overlapping steel plates which form steps. As the drum revolves the balls drop over the steps, pounding the material to pieces. The ground material passes from the drum through screens.

Ball mills are much used for the grinding of material to a fineness of 30 to 40 mesh. A *tube mill* (Fig. 11) differs from the ball mill in having less diameter and greater length of the drum or wrought iron tube, having usually a diameter of four or five feet and a length of twenty feet. Its axis is nearly horizontal and it revolves on trunnions which rest in bearings at both ends. The tube is lined with porcelain or similar material

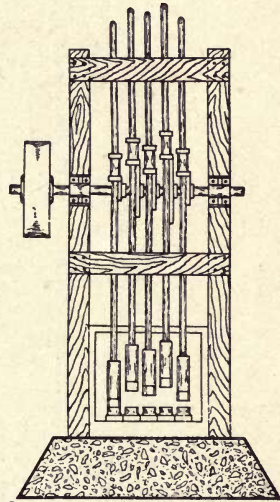

FIG. 9. Stamp Mill.

and is about one-half filled with flint pebbles. The tube mill is rotated slowly at about 22 to 27 turns per minute, and the

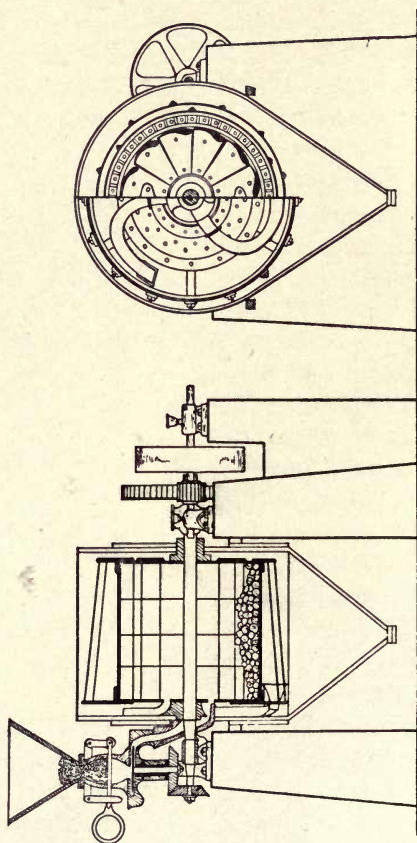

FIG. 10. Sections through a Commercial Type of Ball Mill.

ground material is discharged through a sieve into a bin or conveyor underneath. The grinding in tube mills is often to a fineness of 100 to 200 mesh.

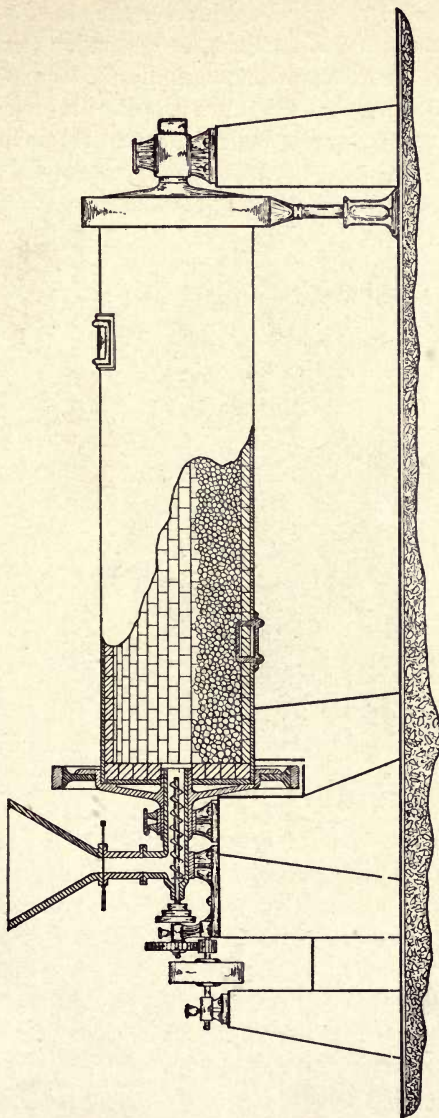

FIG. 11. Tube Mill.

Griffin mills (Figs. 12 and 13) involve the use of a crushing roll revolving against a fixed ring or die under a centrifugal force, while in the *Fuller mills* the grinding is done by four unattached chilled iron balls that are propelled by four equidistant horizontal arms radiating from a vertical central shaft, the grinding being done between the surfaces of the balls and the circular steel die constituting their orbit.

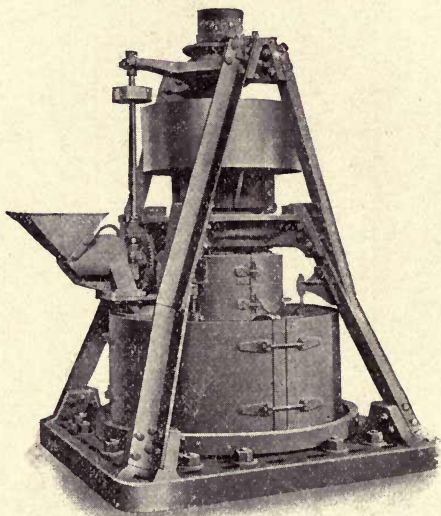

FIG. 12. One Type of Griffin Mill. General View.

In the manufacture of ceramic products the clays and shales are ground and mixed in *disintegrators* and in *dry* or *wet pans*. A type of the former (Fig. 14) may be described as consisting of two rolls, revolving at different speeds. The slow roll driven at 75 to 100 revolutions per minute is the feed roll. The speed roll is driven at 650 to 800 revolutions per minute. It is fitted with eight steel bars known as the cutting bars. The material to be ground is introduced through a hopper at the center of the apparatus.

The *wet or dry pan* (Fig. 15) is used for crushing lumpy clays and consists essentially of a pan and runner revolving in opposite directions. The bottom of the dry pan consists of a sieve through which the ground material is discharged. In the wet pan the ground material is discharged by means of a chute or scraper.

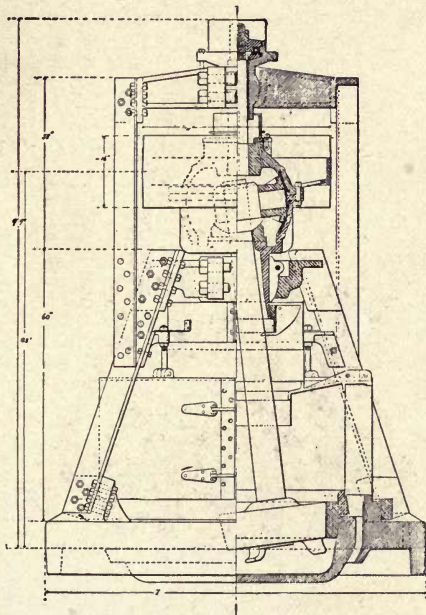

FIG. 13. Griffin Mill (of slightly different design)—Section.

For grinding paste mixtures, such as pigments in oil, *stone mills* (Fig. 16) are used. These consist of two horizontal stones moving in opposite directions. The material is fed from a hopper to the mill and is transferred by centrifugal action to the grinding surfaces of the stone.

The nature of the appliances used in the mixing of materials has already in part been shown in the description of the grinding machines above. Other machines and forms of ap-

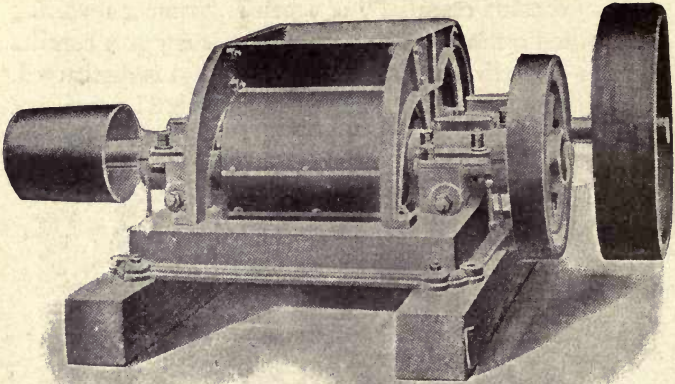
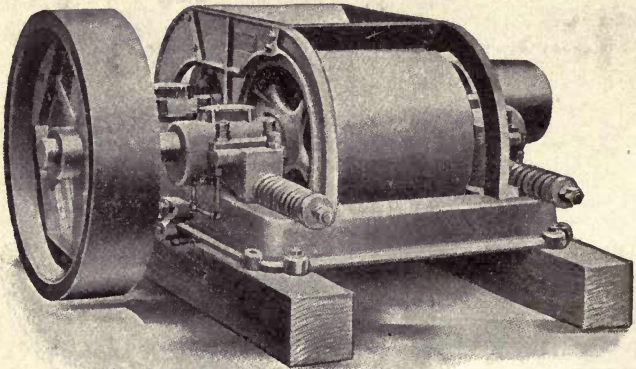

FIG. 14. Clay Disintegrator.
(A) Front View.



(B) Rear View.

paratus are, however, especially adapted for the mixing of various kinds of materials. *Mixing machines* (called kneading machines when the material to be mixed is wet), in general, consist of a receptacle containing mixing blades or arms which

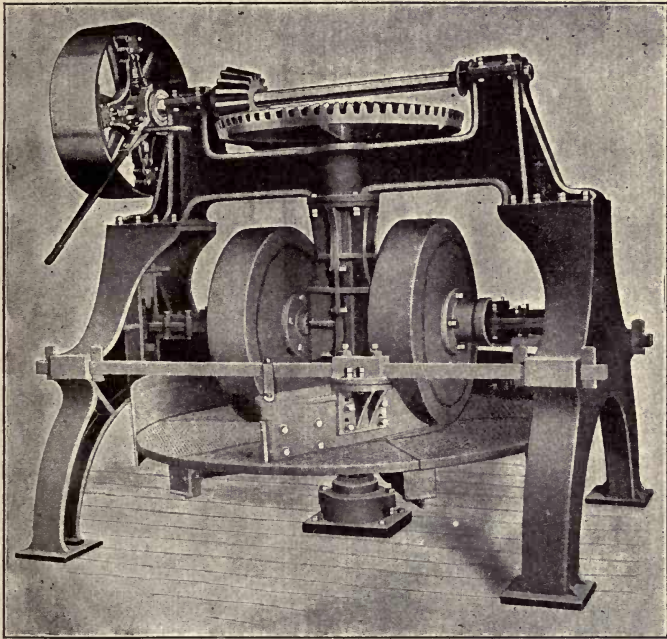

FIG. 15. Dry Pan.

possess different forms according to the requirements of the particular material to be mixed.

For the stirring and agitation of liquids or their saturation with gas the steam jet agitator may be used. The action of the steam in issuing from a small nozzle into a larger one is to give the surrounding air a velocity sufficient to overcome a pressure of fully eight feet of water. When the discharge pipe from a steam jet blower is immersed in a liquid the escape

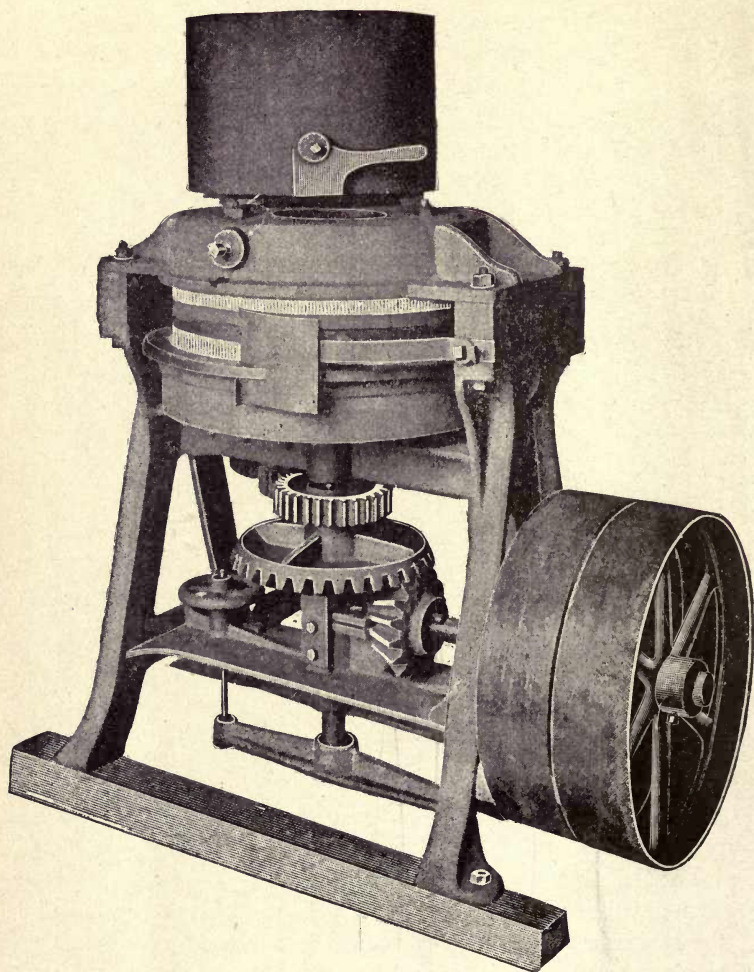

FIG. 16. Stone Mill.

of air causes violent agitation and effectively stirs up any solid matter resting at the bottom of the tank. In many cases the admission of air and its use for the agitation of liquids is not permissible. *Mechanical agitators* similar to the mixers already discussed are therefore employed. The receptacle is fitted with an agitator consisting of a series of paddles set at an angle. This gives the mass being agitated an upward motion and insures thorough mixing.

III. CALCINATION AND FUSION

The chemical industries make use of various forms of furnaces to furnish the proper temperatures at which the reactions necessary for a given product may take place. For example, the cement industry makes use of a rotary kiln fired by an oil burner (Figs. 35 and 36). The ceramic industry utilizes a method of direct firing from the usual type of fire boxes, the down draft and large area of kilns giving a method of excellent control (Fig. 45).

For general purposes of heating and calcination, i. e., the heating of materials to remove water or burn out organic matter, the regenerative furnace designed by Siemens may be taken as a type. In such a furnace the fuel may be either an industrial gas or the gases liberated during incomplete combustion, the construction of the furnace being such as to yield the maximum heating effect from minimum fuel consumption. In the regenerative furnace of Siemens (Fig. 17) the gas enters the gas regenerative chamber and passes up between the checkerwork of bricks, laid with many spaces between, and enters the melting hole. The air enters and passes up through its regenerative chamber, meeting the gas at the melting hole. They there combine and, passing through the melting hole, divide into two parts which pass through the regenerative chambers on the other side. Previous to beginning the operation, all of the brickwork in the

regenerative chambers has been heated red hot by means of a wood fire. The gas and air have therefore absorbed a good deal of heat from the brickwork before they meet. As they

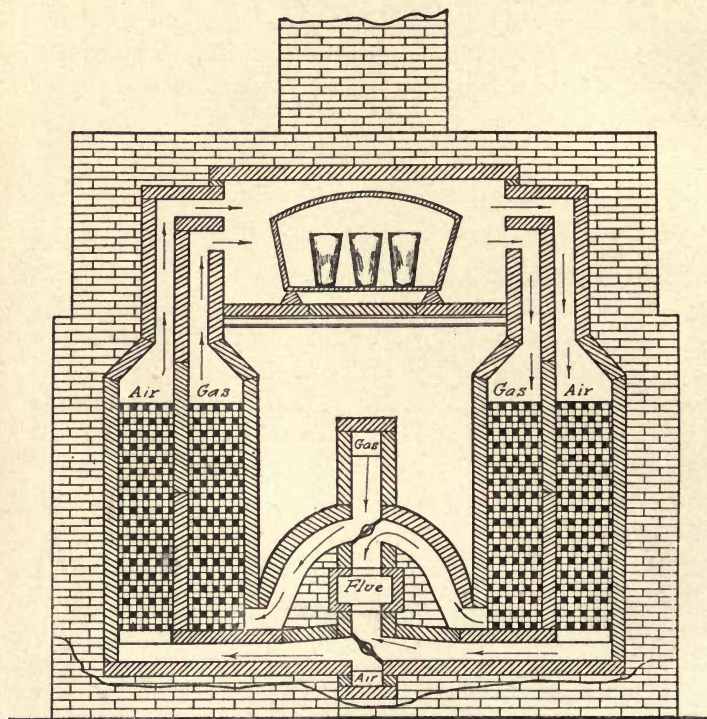

FIG. 17. Siemens Regenerative Furnace.

pass down through the regenerators on the outgoing side, they will still further increase the heat of this brickwork, giving up their temperature to the checkerwork. This causes them to go to the stack at a relatively low temperature, and when the current of air and gas is reversed, each now entering from the other side, they become more highly preheated than before, thus serving to heat the opposite pair of regenerators.

After all four regenerators have been raised to a high temperature, the reversal of direction takes place about every 20 minutes, and thus a uniformly high temperature is obtained with low temperature of chimney gases and resultant fuel economy.

IV. EVAPORATION AND DISTILLATION

The process of evaporation is carried on by means of heat from furnaces or from steam. Steam is applied either by

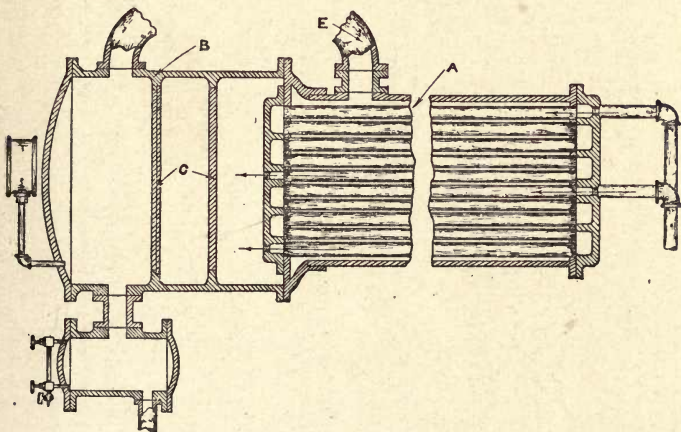

FIG. 18. Section through a Yaryan Evaporator.

means of coils in the liquid or by means of a jacket which surrounds the vessel as in the so-called steam jacketed kettles. In order to keep the contents of such vessels uniformly heated many of them are provided with agitators or stirrers driven mechanically. By subjecting the space above the liquid to a diminished pressure or vacuum, the boiling point of the liquids will be materially lowered and lower temperature (exhaust) steam may be used. To effect a still further economy the principle of multiple effect evaporation is often employed.

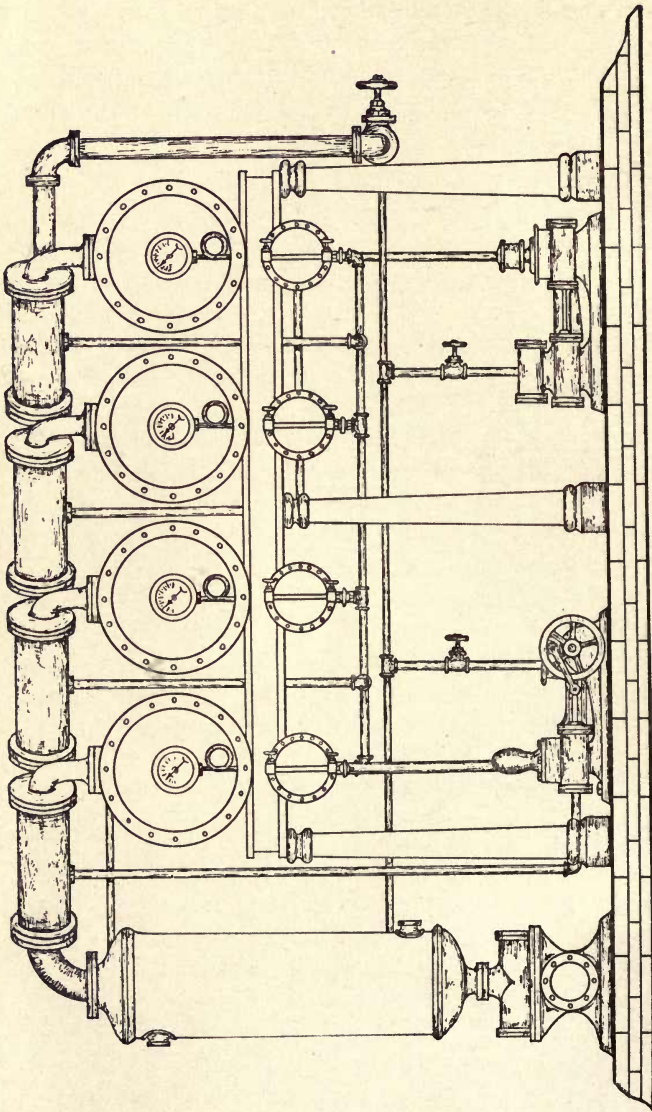

FIG. 19. Quadruple Effect Evaporator of Yaryan Type.

To secure this effect the steam evolved in evaporation may be led into another set of steam coils and used again for evaporation. An example of multiple effect evaporators may be found in the Yaryan type (Figs. 18 and 19), which is frequently employed in chemical industries.

The operation of the Yaryan evaporator consists in feeding the liquid into the evaporator in such a manner as to keep it in rapid motion and in contact with the heated surface for a very short time. The apparatus consists mainly of a series of tube coils (*A*—Fig. 18) which carry the liquid. These coils are placed within a cylindrical chamber into which steam at (*E*) is admitted. The liquid is fed into the coils in a small continuous stream, is immediately converted by the heat into a mass of spray in which the proportion of steam (vapor) continuously increases as it rushes along at a high velocity, and is finally discharged into the separator, *B*. The latter is a chamber fitted with baffle plates, *C*, which serve to remove the entrained liquid from the steam, the former falling to the bottom and being conducted into coils, while the latter is led into the second effect where its heat is utilized to evaporate the liquid passing through a series of coils similar to the first "effect." In the second "effect" the liquid from the separator of the first effect is therefore partially vaporized. This process may be repeated in a triple or quadruple effect (Fig. 19). Finally the steam from the last effect is condensed, forming thereby a high vacuum in the separating chamber and consequently in the coils, and lowering the temperature at which the liquid would boil at ordinary temperatures. It will be seen from this description that in multiple effect evaporators of this type a gradual reduction in pressure and boiling temperature occur, which reduction is so adjusted that the liquid is brought to its boiling point by the steam produced by its own evaporation in the preceding effect.

Among other types of evaporators may be mentioned the Ordway apparatus, in which alternate cooling and heating is

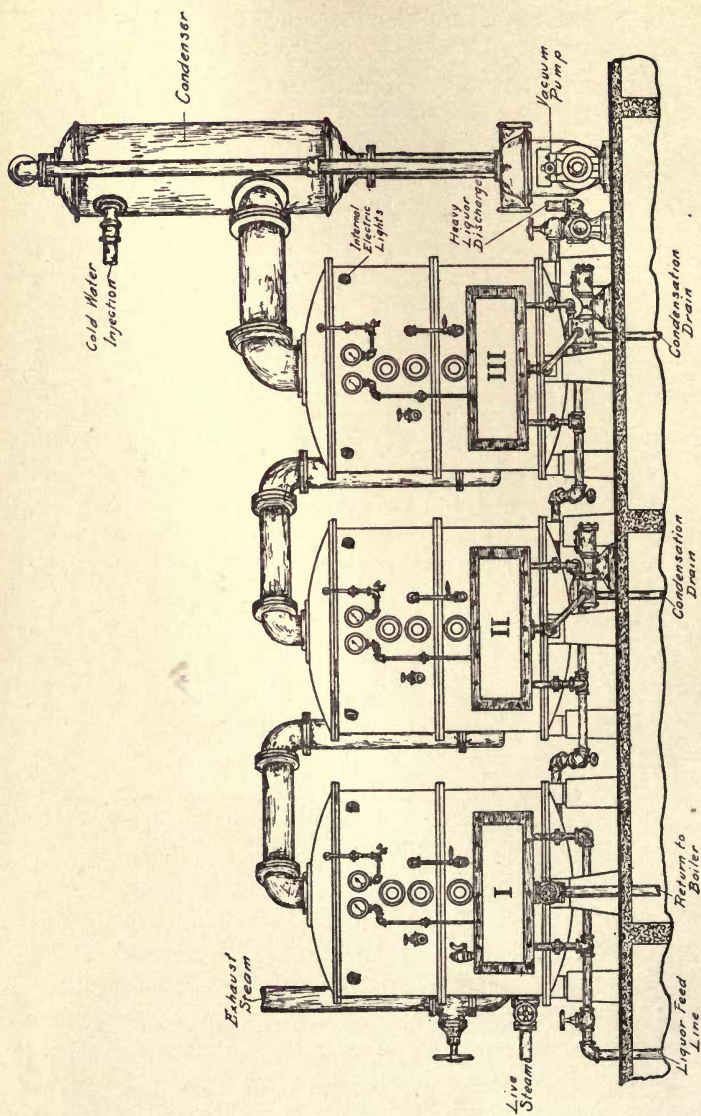

FIG. 20. Zaremba Triple Effect Evaporator.

utilized for the removal of solids in solution; the submerged tube evaporator represented by the Swenson and Zaremba (Fig. 20) evaporators, in which the steam is carried within tubes submerged in shallow layers of liquid; and the so-called "climbing film" evaporator (Fig. 21) in which the liquid in

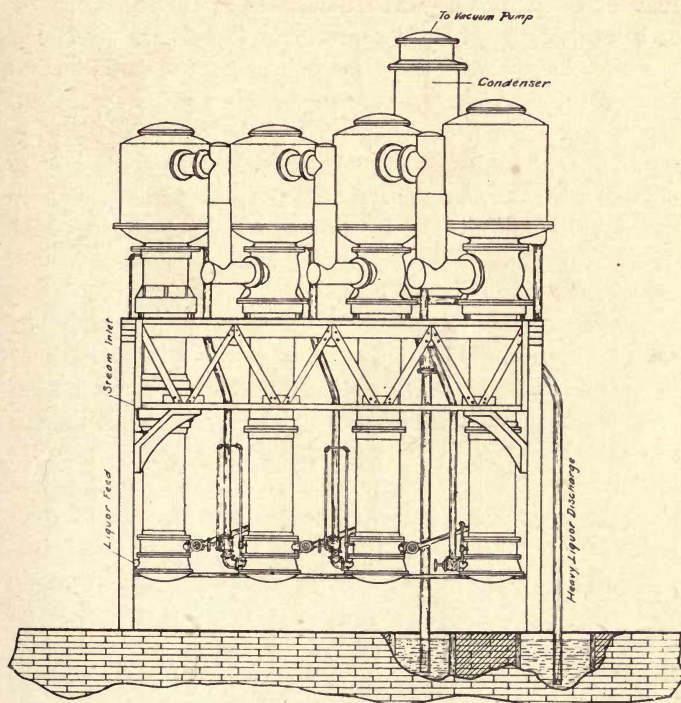

FIG. 21. Kestner Climbing Film Evaporator.

the bottom of long vertical tubes (about 23 feet in length) in boiling carries a thin film of liquid which is discharged against the vanes of a centrifugal separator and thence into the bottom of a set of tubes in the second effect.

Distillation is a case of evaporation, in which, by conduct-

ing the vapors through condensers, separation of one liquid from another may take place, for example, the removal of carbon disulphide from a solution of petroleum oil in carbon disulphide. When there exists a considerable range between the boiling point of the respective liquids, their separation may be effected in a plain still, heated in the same manner as in evaporation, but, in cases where liquids are volatile in steam or have nearly the same boiling points, distilling columns are placed intermediate to the still and its outlet. In the former case, i. e., in the use of the ordinary pot still, separation of the constituents comprising the liquid is only partial, since the composition of the vapors which arise from the liquid bears a direct relation to the composition of the liquid in the still. Accordingly, the greater the proportion of heavy constituents in the liquid the greater their proportion in the vapor, and in a mixture of light and heavy liquids even the first portion which passes over carries with it more or less of the higher boiling constituents. To secure more complete separation it is necessary to make repeated distillations into fractions or else use a column still (Fig. 22). The latter consists essentially of a number of small simple stills placed one above the other in the same column. When a liquid composed of a number of constituents of different boiling points begins to vaporize and the vapors encounter the perforated plates or capped openings, partial condensation of the heavier constituents takes place, leaving the lighter vapors to pass upward where the same operation takes place. Finally the vapors that reach the top of the still are, in the early stages of the distillation, nearly pure or at least represent a definite mixture. Column stills are either continuous in operation or periodic. In the latter case distillation is discontinued from time to time, the residues emptied out, and the still recharged for another distillation.

In Figure 22 is an illustration of a type of still used in the recovery of alcohol from fermentation of substances contain-

ing sugar. The fermented liquor enters through the feed pipe and passes through the preheater, *A*, where a portion of the liquor is vaporized and passes into the primary column, *B*, at the top, while the unvaporized portion of the liquor flows into the column, *B*, above the boiling chambers, *c*. Here the

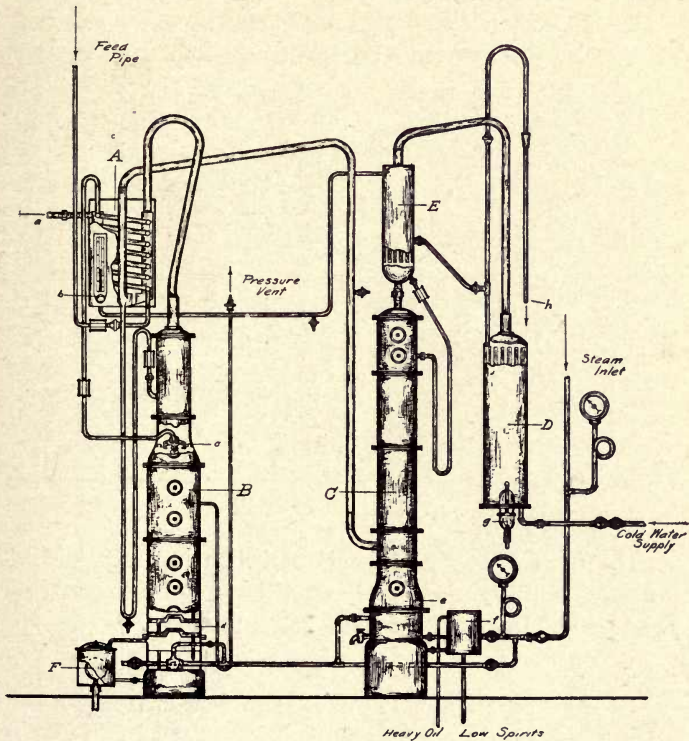

FIG. 22. Continuous Column Still.

lighter components are vaporized while the heavier constituents continue to drop upon the lower series of boiling chambers at *d*, and finally are discharged through an automatic device, *F*. The ascending vapors next pass into the rectifying

column, *C*, where further separation by means of boiling chambers at *e* and in the condenser, *E*, takes place. The high boiling constituents may be withdrawn at *f* from the bottom of this column while the lighter vapors pass into the condenser, *D*, where final condensation into high proof alcohol takes place and is withdrawn at *g*.

The efficiency of distillation is sometimes greatly increased by the use of a vacuum pump attached to the receiving

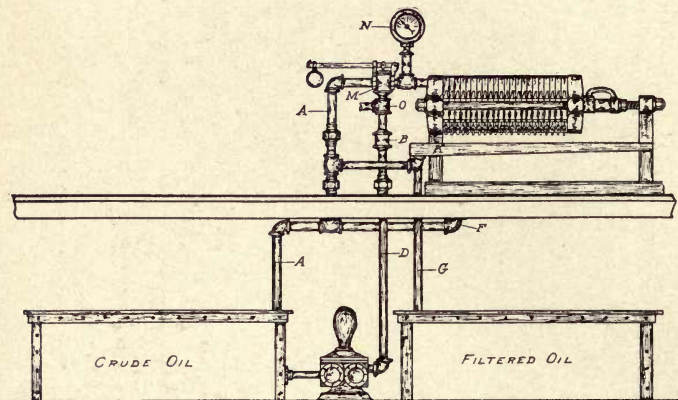

FIG. 23. Filtration of Crude Oil.

vessel. In this way distillation is carried on under diminished pressure or "in vacuo," resulting in the use of a lower temperature and frequently yielding better products.

V. SETTLING, FILTRATION AND SEPARATION

For the separation of a liquid from a solid, or vice versa, a number of appliances are used, such as filter presses, centrifugal machines, hydraulic presses and extraction apparatus. The simplest and most widely used method of separation is that of *settling* the solid by gravity. The usual form of apparatus is a tank or a series of tanks. The mixture to be

separated is run into the tank, allowed to settle, and the liquid drawn off carefully so as not to disturb the settled portion. The settled portion is then flushed out through a cock at the bottom of the tank. *Filter presses* represent in large scale operation what is accomplished in the laboratory by the use of the funnel and filter paper. The filter press consists essentially of a series of chambers made by alternately placed plates and frames forming a solid edge or margin with projecting lugs resting on a

pair of parallel bars. The filtering medium, consisting of cloth or paper, is stretched over the surface of each plate, the plates are then forced together by means of a heavy screw, and the material to be filtered is pumped into the press through an inlet in the head of the press and distributed over the surface of the filtering medium. The liquid passes through the cloth, is collected by grooved channels on the plates and delivered to receptacles, while the solid is retained in the

frame or recessed plate and finally formed into a cake. The latter may be washed by a repetition of the process using liquid suitable to the particular solid separated.

Figure 23 shows an installation of a Sperry filter press for filtering crude oil. The gauge and air chamber "N" is connected to the head of the press; to this is screwed the relief valve "M." Below this the tee "O" is connected to receive the steam or air supply for blowing out the press. Below this

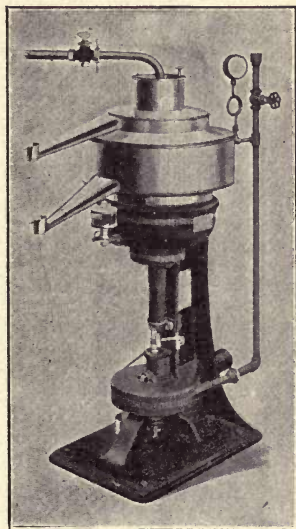

FIG. 24. Centrifugal Separator.

comes the check valve "B," then the union connecting pipe "D" leading to the discharge pipe of the pump. After passing through the press the filtered oil passes to the gutter "K," which is connected to the filtered oil tank through pipe "G."

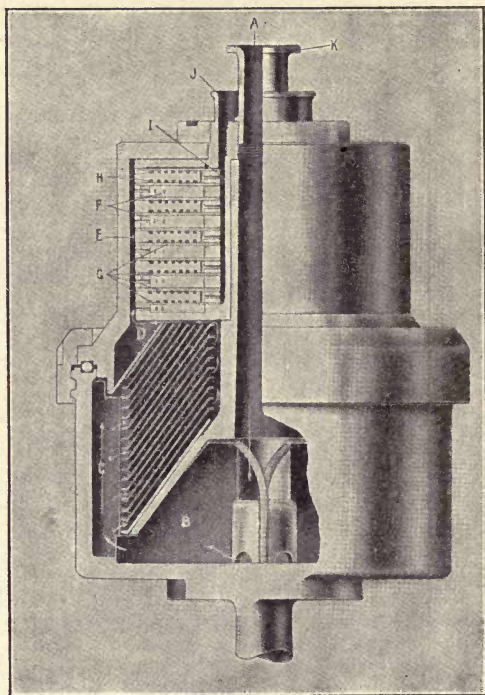

FIG. 25. Bowl of Centrifugal Separator.

The drip-pan of the press should be connected by pipe "F" to the crude pipe "A."

Centrifugal machines are extensively used in the separation of cream from milk and are being rapidly introduced into many chemical industries. They separate solids from liquids by centrifugal force generated by a high speed of rotation.

This throws the solid or heavier particles towards the walls of the basket while the liquid simultaneously escapes through perforations of the basket into the curb. The average surface speed is about 10,000 feet per minute. Figs. 24 and 25 show the construction of the DeLaval separator which is typical of this kind of apparatus. Centrifugals are also much used for separating oil from water.

Hydraulic presses are used largely for the expression of oil or heavy liquids from solids, although frequently the primary purpose may be to free the solid from adhering liquid. Under this head should also be considered mechanical presses. The latter are driven by belts from some form of mechanical power and are often equipped with automatic regulators to stop the press after a certain compression has been attained. The hydraulic press (Fig. 26) consists of the press proper and the press pump. The latter is usually of the plunger type and produces a pressure on the liquid of the pump, this pressure being transmitted to the liquid in the cylinder, thereby exerting the same pressure per unit area upon the piston of the press as exists upon the piston of the pump.

Extraction by chemical solvents is a well known method (Soxhlet apparatus) in the laboratory. It is practiced on a large scale in a number of industries, the production of rosin from pine chips being an industrial example. Various forms of apparatus are in use but the principle involved is the same in all cases. The solid material is treated with a solvent which dissolves the oil or other substance to be separated. The resulting solution is then delivered to a still where the solvent is removed and recovered, leaving the extracted substance in the still, whence it may be drawn off in a relatively pure condition.

VI. DRYING APPLIANCES

The removal of liquid, especially water, from raw materials, and finished products requires a number of forms of

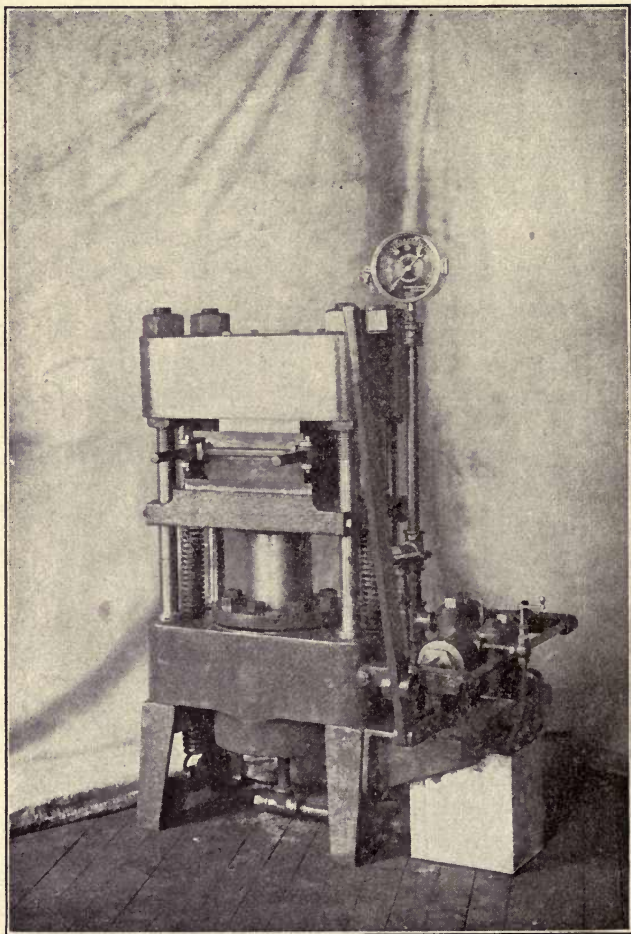

FIG. 26. Hydraulic Press.

apparatus. As already pointed out, the bulk of liquid is removed by a mechanical operation, such as filtration or centrifugal force. In order completely to remove the water or adhering liquid, contact with air is often necessary. To hasten the operation heated air is applied by numerous devices. The most primitive method is that of the *hot plate*, which consists essentially of a platform of iron or clay plates, heated by a fire underneath or by chimney gases conducted through flues underneath the plates. This system proves economical in those industries where there is a large amount of heat that otherwise would be lost, as in the drying of brick by the gases from the kilns (Chapter XI) and the drying of acetate of lime by the heat radiated from the retorts (Chapter IV). To facilitate the circulation and motion of drying gases, fans of the blower or exhaust type are often employed and special drying chambers are built in such a way as to favor the speedy removal of the air after its saturation point (i. e., its maximum moisture carrying capacity for a given temperature) has been reached.

When applicable, one of the most economical kinds of drying apparatus is the *rotary dryer*, in which the material to be dried is kept in constant motion. The method of operation of a common type of the rotary drier, as shown in Fig. 27, is as follows: The heated air and products of combustion from the furnace pass through the brick lined connecting flue into the inner shell to the rear end, whence they return, through the drying material and an exhaust fan or stack to the outer air. The material is fed through the front head into the space between the two shells, is picked up by the lifting buckets and dropped into the inner shell. By the revolution of the machine it is dropped again to the outer shell, the operation being repeated until, due to inclination of the machine, it reaches the rear end where it is elevated and discharged through the center of the rear head. On entering the machine the temperature of the products of combustion is about

1400° C., but they begin to transfer their heat at once, through the wall of the inner shell to the cold and wet material held on top of it by the radial vanes. As they pass toward the rear end they give up practically all their heat, so that when they turn to pass back through the drying material they have been reduced to about 250° C. Additional outside air is then admitted to mix with them, so that the outside shell is cool at all times and the loss by radiation is practically nothing. In passing back through the drying material from the delivery end to the feed end, they are still further reduced in temperature until, when they pass out through the fan or stack, they have been reduced to 100° C. or less. It is claimed that 88 per cent of the fuel value is utilized in this type of drier.

For the drying of materials which may be damaged by high degree of heat, as in the case of

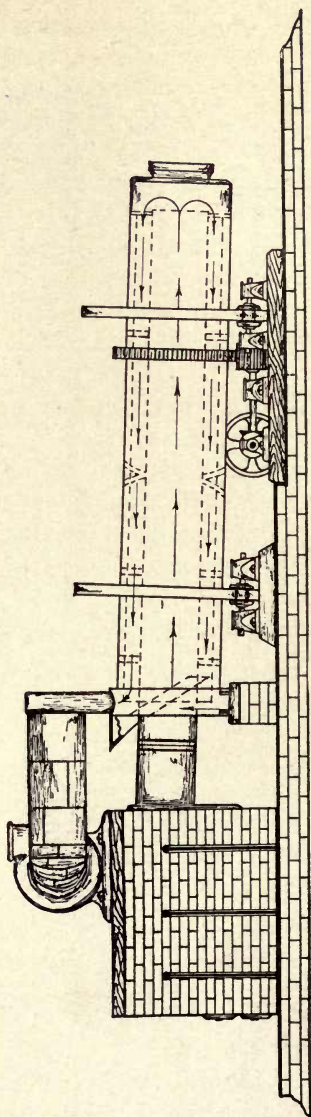

FIG. 27. Rotary Drier.

many organic and crystalline hydrated inorganic compounds, a system of vacuum drying is commonly employed. This method of drying accomplishes a great saving in time, labor, and fuel.

REFERENCES

I

- DAMOUR: Industrial Furnaces.
 DELAVAL: Centrifugal Pumping Machinery.
 DYSON AND CLARKSON: The Design, Erection and Equipment of Chemical Works.
 GREENE: Pumping Machinery.
 HAUSBRAND: Evaporation, Condensing and Cooling.
 HISCOX: Compressed Air.
 MARLOW: Drying Machinery and Practice.
 NAGEL: The Mechanical Appliances of the Chemical and Metallurgical Industries.
 ROGERS: Laboratory Manual of Industrial Chemistry.
 ROGERS AND AUBERT: Industrial Chemistry.
 THORPE: Industrial Chemistry.
 WOOD: Water and Gas Works Appliances and Pumping Machinery.
 YOUNG: Fractional Distillation.

II

- SNOW: Mechanical Transportation of Air. *Eng. Mag.*, **28**, 541 (1905).
 LEWIS: Theory of Fractional Distillation. *J. Ind. Eng. Chem.*, **1**, 522 (1909).
 SADTLER: Vacuum Evaporation. *J. Ind. Eng. Chem.*, **1**, 644 (1909).
 HIRSCH: Differential Condensation in the Distillation of Binary Mixtures. *J. Ind. Eng. Chem.*, **2**, 409 (1910).
 NAGEL: Dissolving Chemicals and Agitating Solutions. *J. Ind. Eng. Chem.*, **2**, 341 (1910).
 DELAVAL CENTRIFUGAL CLARIFIER AND FILTER. *J. Ind. Eng. Chem.*, **3**, 771 (1911).
 KERR: Experiments on Drying by Gas. *Mod. Sugar Planter*, **41**, 13 (1911); also *Chem. Abs.*, **5**, 2442 (1911).
 MOSS: A Study of Mechanical Conveyors. *Sch. Mines Quar.*, **33**, 136, 233 (1912).

CHAPTER II

THE ATMOSPHERE

THE atmosphere is much less complex than either the earth's crust or natural water. In general it may be considered as primarily a mixture of three components, oxygen, nitrogen, and argon. The various other substances found in air, important as they are, may be looked upon as impurities. The relative quantities of oxygen, nitrogen, and argon are, according to Sir William Ramsay, as follows:

| | <i>By weight</i> | <i>By volume</i> |
|-------------------|------------------|------------------|
| Oxygen. | 23.024 per cent | 20.941 per cent |
| Nitrogen. | 75.539 “ | 78.122 “ |
| Argon. | 1.437 “ | .937 “ |

With the argon occur the so-called inert gases, helium, neon, krypton, and xenon, all of which are present in minute quantity (about 1 part in 1 to 100 millions). In addition to the elements above enumerated, ordinary air contains a variable quantity of water vapor, about 0.04 per cent carbon dioxide, and an exceedingly variable amount of dust which includes both inorganic matter and organic matter living and dead. At certain times or in certain places measurable amounts of other substances are found in the atmosphere.

From an industrial standpoint interest in the atmosphere is largely centered in its sanitary control, as in ventilation, air purification and humidification; in the effect of its impurities upon industrial operations; in its use as a drying, heating and cooling agent; as a source of supply for the manufacture of nitrates and other nitrogen compounds; and as the main source of supply of oxygen for combustion of fuels.

COMPOSITION AND SANITARY PROPERTIES OF AIR

Oxygen.—As above noted, about one-fifth of the volume of air consists of oxygen. Some of this is consumed by the processes of respiration, fermentation, combustion and decay, carbon dioxide and water being the chief final products. Some oxygen is also consumed in the “fixation of nitrogen” (q. v.) and in the oxidation of sulphides to sulphates. These losses are balanced by the processes of plant growth, in which by means of the energy of sunlight acting through the agency of the chlorophyll cells, carbon dioxide and water react with the (ultimate) production of carbohydrate and liberation of oxygen. These processes are so nearly equal that the average oxygen content of the air is practically constant.

The function performed by the oxygen of the air in respiration is similar to that in the ordinary processes of combustion (q. v.). Expired air is richer in carbon dioxide and poorer in oxygen than ordinary air, as illustrated by the following typical analyses:¹

| | <i>Normal air</i> | <i>Expired air</i> |
|-------------------------|-------------------|--------------------|
| Oxygen. | 20.8 per cent | 15.4 per cent |
| Nitrogen. | 79.2 “ | 79.2 “ |
| Carbon dioxide. | 0.03 “ | 4.33 “ |

Accordingly it follows that the function of the oxygen is to burn the foodstuffs which serve as fuel to the body whereupon the resulting carbon dioxide is expelled through the lungs.

Industrially oxygen is beginning to assume an important rôle. The most economical production is by the distillation of liquid air. Liquefaction is accomplished when air is compressed and then cooled by a portion undergoing adiabatic expansion in the apparatus of Claude² or by the Linde

¹ Billings: Ventilation and Heating, p. 87.

² *Compt. rend.*, 1900, II, p. 500; 1905, II, pp. 762 and 823; also Ewell: Physical Chemistry, p. 131.

process, in which air is compressed under about 200 atmospheres of pressure and a portion of the air thus compressed is allowed to expand through a small opening. Under atmospheric pressure nitrogen boils at -194° C. and oxygen -185° C. This difference of boiling points enables an almost complete separation of oxygen and nitrogen to be made. The Linde process has found successful application on a commercial scale and has greatly increased the uses to which pure oxygen may be applied. Its use therapeutically and in submarine boats and nautical chambers is well known and it constitutes an important feature in the equipment used in mines rescue work.

Nitrogen.—In the free state and under the ordinary conditions of the atmosphere, nitrogen is relatively inert. The nitrogen compounds are however essential constituents of plants and animals and are important agents in agriculture and in many manufactures. By means of an electric discharge nitrogen may be caused to combine with oxygen and hydrogen. Rain water after a thunderstorm usually contains small amounts of nitrites and nitrates. The recently developed methods of manufacturing nitrates and ammonia from atmospheric nitrogen are of great interest at the present time and are discussed more fully elsewhere in this chapter.

Carbon Dioxide.—The amount of carbon dioxide in rooms and audience chambers is often taken as an index of the purity of the air. The quantity in outdoor air is not constant, as may be seen from the following amounts quoted from Billings, p. 65:

| | <i>Parts in 10,000 of air</i> |
|------------------------------|-------------------------------|
| Geneva, Switzerland. | 4.6 |
| Munich, Germany. | 3.7 |
| London, England. | 3.8 |
| Baltimore, U. S. A. | 3.7 |
| Sea air. | 2.69 to 3.12 |

In public halls and theaters the amounts are often very much greater, as is indicated in the following analyses ¹ made on samples of air from buildings in Boston:

| | <i>Parts in 10,000</i> |
|--|------------------------|
| Boston theater. | 39.13 to 44.72 |
| Globe theater ($\frac{3}{4}$ full). | 23.38 to 35.88 |
| Globe theater ($\frac{1}{2}$ full). | 19.00 to 24.72 |
| Huntington Hall. | 18.48 to 17.24 |
| Y. M. C. A. Building. | 36.43 to 32.59 |
| Trinity Church (Gallery). | 20.52 to 19.12 |

Carbon dioxide is a colorless gas, one and a half times heavier than air. It is a product of combustion, respiration, oxidation of organic matter in decay and fermentation, volcanic action, and chemical action. Its use in fire extinguishers is based on the fact that air, in which the oxygen is reduced to 18.5 per cent, containing 2.5 per cent carbon dioxide, does not readily support combustion.

Industrially carbon dioxide is used for carbonating beverages and in the liquefied form serves as a refrigerating agent for cold storage and low temperatures. The annual output of liquefied carbon dioxide from 40 factories in the United States is about 30,000,000 pounds.

Water Vapor.—The amount of water vapor (moisture) present in the atmosphere is a very important factor in producing physical comfort or discomfort. The term used to express the amount of water in the air is *humidity*. Actual humidity refers to the actual weight of water vapor present in a given unit volume of the air. Relative humidity expresses the relation between the vapor actually present at a given temperature and that which the air would contain if saturated at that temperature.

Relative humidity is determined by several methods, the more usual one being to measure the difference of tempera-

¹ Woodbridge: *Tech. Quar.*, Vol. 2, No. 2.

ture as recorded by "wet" and "dry" bulb thermometers. The wet bulb should be tightly covered with clean muslin and moistened with distilled water. The muslin should be renewed from time to time, as by long use it may tend to become stiff and to absorb the water less readily. The two thermometers are placed side by side in the air current to be measured, taking care to keep the dry bulb sufficiently far away from the wet bulb so as to remain unaffected by the moist air. For good results, the current of air whose humidity is to be determined should have a velocity of not less than 15 feet per second.

After the correct differences between the temperatures of the dry and wet bulb thermometers have been found, the relative humidity may be found by consulting Fig. 28, in which T is the temperature recorded by the dry bulb; T_2 is that recorded by the wet bulb; and $T - T_2$ the depression of the wet bulb thermometer. The actual humidity increases greatly with increase in temperature. The relative humidity will therefore give no idea of the actual amount of water carried by the air unless we know the water content of saturated air for that temperature. This relation is graphically expressed in the hygrometric chart (Fig. 28) where the curved lines represent relative humidity in percentages, the horizontal line of figures indicates the grains of moisture per cubic foot of air and the vertical figures are degrees of temperature on the Fahrenheit scale.

If for instance the dry bulb thermometer reads 70° , and the wet bulb 62° , the difference ($T - T_2$) or "wet bulb depression" is 8° . On the chart under the heading "Difference in Temperature between Dry and Wet Bulb Thermometer ($T - T_2$)," will be found curved lines sloping downward to the left. Follow the 8° line until it intersects the dry bulb temperature and the relative humidity will be found from the scale at the bottom of the chart to be $63\frac{1}{2}$ per cent. The absolute humidity may be similarly ascertained by following the

curved line sloping to the right from the same point of intersection and reading from the scale at the right of the chart which shows in the case here cited 5 + grains of moisture per cubic foot of air.

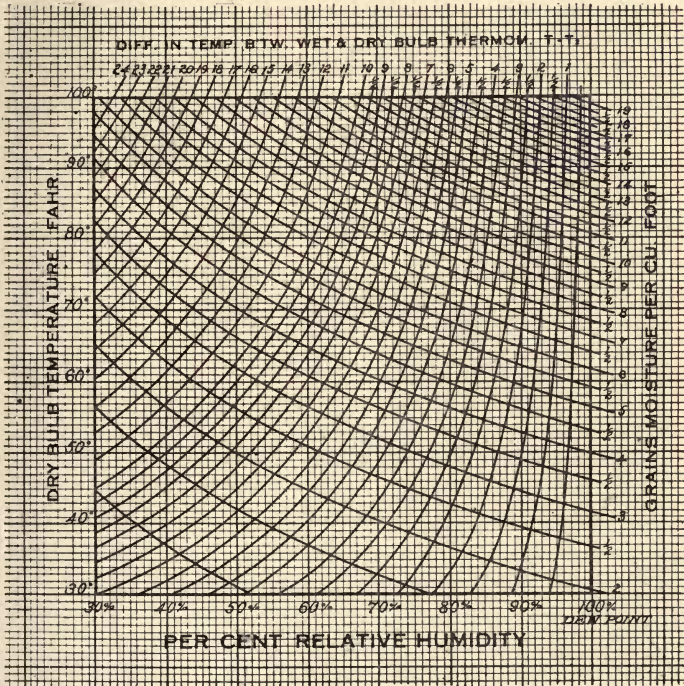

FIG. 28. Hygrometric Chart.—Copyrighted by Warren Webster and Company, reproduced here by special permission.

The amount of moisture present in air at complete saturation varies greatly with the temperature. To saturate a given volume of air requires 30 times as much moisture at 100° F. as at 0° F. When the temperature is 70° F., a relative humidity of 70 per cent is very comfortable, but at 90° F.

with a humidity of 90 per cent the conditions are almost unbearable.

When the temperature is suddenly reduced so as to fall below the temperature at which the air is saturated, i. e., 100 per cent humidity for that temperature, we have a condensation of moisture. This represents the dew point for the amount of moisture retained.

The humidity of the atmosphere has an extremely important influence upon many industrial operations.

Carbon Monoxide.—This gas is sometimes a constituent of the air of rooms due to leakage in the draft of stoves and furnaces, or of gas fixtures. It is extremely poisonous, less than 1 per cent being sufficient to cause death when breathed for several minutes. It is also found in coal mines, where the timbering has been charring, or as the result of explosions. Its effects are said to be as follows:

| <i>Carbon monoxide in air, per cent</i> | <i>Time breathed</i> | <i>Effects</i> |
|---|----------------------|-------------------------------------|
| 0.05 | 30 minutes | dizziness. |
| 0.10 | 30 minutes | weakness; loss of control of limbs. |
| 0.20 | 30 minutes | loss of consciousness. |
| 1.00 | several minutes | loss of consciousness and death. |

When mixed with air in the proportions 2 of carbon monoxide to 5 of air, it forms an explosive mixture. It is often seen burning with a blue flame above a fire of coked coals. It is a constituent of blast furnace gas, of water gas, and of producer gas.

Odors.—In populous centers the gases of decomposition and putrefaction are occasionally noticeable constituents of air. They are formed from the breaking down of organic matter containing nitrogen and sulphur. *Sulphur dioxide* is produced in the combustion of coal containing pyrites (Fe S_2). Its presence in gases from coal stoves is usually easily detected by its pungent odor. It is also discharged in large quantities

from smelters¹ and metallurgical plants treating sulphide ores. Mingled with the moisture of the air it becomes a very active corrosive agent, as is evidenced from the destructive action on bridges and other metallic structures in the path of locomotive gases. Its action on animal life in the small quantities usually existing in the air² is not markedly injurious but the effects on vegetation even in minute quantities are very destructive. *Hydrogen sulphide* is liberated in the breaking down of many organic compounds, but ordinarily in such minute quantity as to be of inappreciable effect. *Ammonia* is formed from vegetable and animal matter and is usually present in traces in the air as ammonium salts. *Methane* is formed from the decomposition of vegetable matter and escapes from stagnant pools in bubbles. Both ammonia and methane are present in such minute quantities in ordinary air that their effects are of no importance.

Suspended Matter.—The particles in suspension are of various types. By collecting the dust particles upon a nutrient material, or culture, it is possible to get an idea of the number of micro-organisms in the air of a room or locality. According to Aitken³ the number of dust particles present in a cubic inch of country air is estimated at 2,000; in city air 3,000,000; and in air of an inhabited room in the city, 30,000,000. Among these millions several hundred micro-organisms, chiefly moulds and bacteria, may be found, some of them possibly of a pathogenic (disease producing) character. In recent years it is being increasingly recognized that the mineral dusts also are distinctly dangerous for even if not directly poisonous, such dust often brings about conditions

¹ Prof. Cottrell estimates the amount of sulphur passing up the stacks of the largest smelters at 1000 tons per day. See article *J. Ind. Eng. Chem.*, 4, 182 (1912).

² Baskerville has measured the sulphur dioxide content of the air of cities, see summary in Toch's *Materials for Permanent Painting*, p. 179.

³ *Nature*, 31, 265 (1870); 41, 394 (1880).

which make later infection with tuberculosis easy. Dust from the abrasion of hard material is particularly objectionable in this connection because of its cutting effect. Engineers who are responsible for the conditions surrounding their workmen should give special attention to the adequacy of the means provided for the prevention or removal of dust. For further discussion of this important matter, the reader may be referred to Oliver's *Dangerous Trades*.

Combustible dusts floating in the air are dangerous as a possible cause of explosions. It is now believed that coal dust is the cause of many of the explosions so common in coal mines. Similarly combustible dust may cause explosions in mills, as for example in flour mills. Non-combustible dusts such as that of a cement mill evidently will not give rise to this particular danger.

MINE AIR

In deep mines the gases contaminating the air are methane or fire damp, carbon dioxide or black damp, carbon monoxide or white damp, and hydrogen sulphide, or stink damp. The latter is usually the forerunner of fires or spontaneous heating and is a warning to the miner to guard against other gases of a more dangerous nature.

VENTILATION

The purpose of ventilation is to furnish the requisite amount of air of a suitable character for every person within a given building, mine, or other enclosure. Ventilation may consist merely of an exchange of vitiated air for air from the outside, but frequently it has to do also with the heating, purifying and humidifying, and in some cases the cooling of air.

Quantity of Air Required.—Taking average conditions of a man at rest in an audience hall, with temperature 70° F. and humidity 70 per cent, the amount of air expired is 480 cubic

inches per minute. This air will contain about 4 per cent carbon dioxide and 5 per cent water vapor. It will be warmed from 70° to 90° F. and will be about 3 per cent lighter than when inhaled. A considerable amount of water will also be evaporated from the skin, about $2\frac{1}{2}$ pounds daily. In order to carry away this amount of vapor about $4\frac{1}{2}$ cubic feet of fresh air per minute are required. The expired air, however, vitiates the surrounding air and allowance for the diffusion must be made. Although pure air contains 4 parts of carbon dioxide in 10,000 of air it is considered allowable to maintain the air in a state of vitiation represented by 6 parts of carbon dioxide in 10,000 of air, an increase of 2 parts in 10,000 (0.0002). Estimating the amount of carbon dioxide produced by an adult at rest as .6 cubic feet per hour it will require for dilution to this state of purity $0.6 \div 0.0002 = 3000$ cubic feet per hour.

This applies to adults at rest, but this condition is more theoretical than actual, and it is a matter of modern practice to base the amount of air to be admitted upon the actual conditions that prevail. How complex these conditions are may be seen when mention is made of the more usual ones such as climate, artificial illumination, size of rooms, time the rooms are occupied, occupants, their state of health, activity, etc. A good system of ventilation should usually provide for at least 50 cubic feet of fresh air per minute, or 3,000 cubic feet per hour for each person.

Systems of Ventilation.—The methods used to supply fresh air may be classified as follows: (1) natural currents of air entering and leaving rooms through windows, doors, etc.; (2) outlet flues or chimneys, such as open fireplaces, stoves, and flues leading to chimneys; (3) mechanical suction—"exhaust systems"; (4) forced draft, as in the "plenum systems"; (5) combined plenum and exhaust systems; (6) jets of compressed air or steam to set air in motion; (7) sprays of water to produce movement of air.

The best system of ventilation is by a forced draft or a

combination of forced draft and exhaust. The comfort of the body requires not only a sufficient amount of pure air and sufficient circulation of air, but requires that the air shall have the proper degree of warmth and content of moisture. Heating and ventilation may therefore be carried out by the same system.

In the exhaust system a fan is used to withdraw air from an enclosed place. In thus exhausting a room a partial vacuum is created and the movement of air is from without inward. This gives no choice as to the selection of quality of air nor does it provide for the proper heating of the air.

The plenum system forces air into a room and this air supply may be perfectly controlled in regard to purity, temperature, moisture content, and amount. Being under slight pressure the movement of air is outward, preventing the entrance of polluted air into the room.

Combinations of the plenum and exhaust systems have now been brought to a high state of development.

Air Purification.—In localities where the quantity of dust in the air is unusually large it is highly desirable to remove these particles by filtration. A number of methods are used: (1) filtration of air through cheese cloth screens, the solid matter being arrested and deposited, (2) the use of coke washers, where the air passes through columns of moist coke which act as an absorbent, and (3), the water spray system, where the air is washed mechanically. In the latter system (Fig. 29) the outside air, after contact with the preliminary heating or cooling coils (*A*), passes through the spray chamber (*B*) containing a number of specially designed nozzles (*C*) placed in such relation to each other that no air can pass through the spray chamber without encountering particles of water. After depositing all the heavy particles like soot, dust, etc., at the bottom of the tank, and after absorbing all the moisture it will hold, the air passes on to the eliminator (*D*). This consists of a number of baffles so constructed and set

that the air striking against them deposits the dirt laden moisture carried mechanically. Before the air is admitted to the spraying chamber it is first passed over a tempering coil (*B*), and by this means the amount ¹ of relative humidity of the subsequently heated air may be controlled. A purifier of this type ² used in the City Hall, St. Louis, guarantees the removal of 96 per cent of dust, an average relative humidity of 70 per cent, with 3 per cent variation, and a temperature

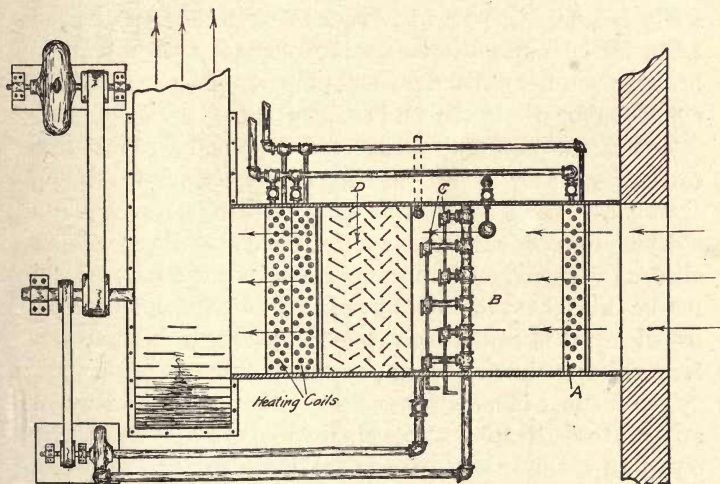

FIG. 29. Plan of Air Purifier.

in summer of not more than 4° above the temperature of water. In winter, use is made of internal circulation by passing the used air through the washers, the impurities being absorbed and enough fresh air admitted and tempered to restore it to a proper degree of purity.

¹ The air cooling system in the New York Stock Exchange takes air at 85° F. and 85 per cent humidity and reduces it to 55° F. and 100 per cent humidity. For description see *Eng. Rec.*, 51, 491 (1905).

² *Eng. Rec.*, 51, 86 (1905).

AIR AS A HEATING AND DRYING AGENT

Heat may pass from a warmer body to a colder by three general methods: (1) radiation, in which the heat waves are transmitted like those of light; (2) conduction, in which heat is propagated through substances by producing a rise of temperature in the latter; and (3) convection, or the carrying of heat due to the motion of the particles which comprise the fluid mass. By this method liquids and gases are almost solely heated. The air of a room therefore becomes heated when by its motion it comes into contact with radiators, heated pipes, hot walls, etc. This property of air is sometimes employed for dessication and evaporation.

The rate of drying depends upon the amount of moisture carried by the air both on entering and on leaving the drying chamber. Thus if air, saturated with moisture, is blown into a drying room of the same temperature as the air, it will not absorb any more moisture and consequently the material will not be dried. On the other hand if the air which leaves the drying room is below the saturation point, it has not performed its maximum drying power and heat is wasted.

The manner in which hygrometric measurements may be applied to dessication may perhaps be better illustrated by citing an example taken from *The Heating and Ventilating Magazine* (Vol. 6, No. 10, p. 16). Assume that the material to be dried enters the chamber at 70° F. and must not be subjected to a higher temperature than 200° F. Assume also the external air to be at 62° F. and 60 per cent saturation, that it enters at 200° F., and that it is completely saturated upon leaving the drying chamber. The problem is to determine the amount of heat to be supplied as heated air to evaporate one pound of water. This may be done by making use of the expression

$$\frac{T-t}{W-y} = \frac{C}{.24 + .475y} \quad \text{in which}$$

T = the temperature of the incoming air,

t = the temperature of the outgoing air,

W = the weight of water in one pound of the air leaving the chamber,

y = the weight of the water vapor in one pound of the entering air,

C = the number of heat units (B. t. u.) required to evaporate one pound of water from the material.

.24 = specific heat of air,

.475 = specific heat of steam.

The value of y may be found¹ from the hygrometric chart (Fig. 28) as follows: 1 cubic foot of air at 62° and 60 per cent saturation will hold .000528 pound of water. At 62° F., 1 cubic foot of dry air weighs .076081 pound, while the weight of the air in a cubic foot of 60 per cent saturated air at 62° F.

is .075233 pound. Hence, $y = \frac{.000528}{.075233}$ or .00702 pound, the weight of the water vapor in 1 pound of air.

The values of C and W depend upon t and the value of the latter must next be found. In an installation it may of course be measured experimentally by means of wet and dry bulb thermometers. To evaluate it without its experimental determination, it is convenient to employ the "cut and try" or "inspection" method. Assume in this case that the value of t is 91° F.; then by means of the hygrometer chart and saturated steam tables the values of W and C respectively may be found. The equation now becomes

$$\frac{200 - 91}{.031942 - .00702} = \frac{1071.6}{.24333} \text{ or}$$

4360 = 4407, which is as close an approximation as can be expected when t is expressed in whole numbers.

By consulting the hygrometric tables it will be found that

¹ Complete hygrometric tables may also be found in Bull. 235, Weather Bureau, U. S. Dept. Agriculture.

1 pound of air at 91° F. and 100 per cent saturation contains .031942 pound of moisture. Therefore in passing through the drying chamber 1 pound of air takes up .031942— .00702 = .024922 pound of water and to evaporate a pound of water it will require $\frac{1}{.024922}$ or 40.1 pounds of air.

The amount of heat required to raise 40.1 pounds of air and its accompanying moisture to a temperature of 200° C. is calculated as follows:

$$(40.1 \times .24 + 40.1 \times .00702 \times .475) (200 - 62) = 1346 \text{ B. t. u.}$$

If the material contains, for example, 50 per cent moisture, we may ascertain the amount of heat required to dry 100 pounds of material per hour by simple calculation thus: $100 \times .50 \times 1346 = 67200$ and the number of pounds of air by $100 \times .50 \times 40.1 = 2005$.

REFRIGERATION

In cold storage plants air is frequently cooled by mechanical refrigeration and distributed to the various storage chambers. It has also been proposed to cool the air admitted to buildings through ventilating systems by refrigeration, but this has not proved generally feasible on account of the expense involved. Its value in such institutions as hospitals, sanitariums, in food distributing stations, in iron and steel manufacturing, and in chemical industry can hardly be estimated in terms of money.

Mechanical refrigeration depends on the fact that a fluid in changing from a liquid to a gaseous condition absorbs heat, which in turn is given off on again resuming the liquid state. These different states are brought about by changes in the pressure exerted upon the gas or liquid. By means of a compressor (q. v.) the refrigerating agent in a gaseous condition is compressed to such a point that it may be liquefied.

For refrigerating agents many different volatile fluids may

be used but those which have proved most practical are anhydrous ammonia (NH_3), and carbonic anhydride (CO_2). The same principle underlies the use of all such liquids, but their varying physical and chemical properties demand differences in the construction and operation of refrigerating apparatus. At the present time ammonia leads the list in popularity and it is safe to assert that in the United States there are now 199 ammonia compression plants sold to one carbonic anhydride system. For ammonia the pressure on the evaporator or absorption side is about 15 pounds and on the liquefying or condensing side about 220 pounds, while for carbonic anhydride it is 300 pounds on the evaporating and from 950 to 1250 pounds on the condensing side.

The operation of an ammonia refrigerating system consists first in the liquefaction of ammonia gas under pressure and condensation. The heat liberated in the compression is absorbed and removed by the condenser waters. The liquid ammonia at a temperature of about 90° F. next flows through a controlling valve into the refrigerator where after expansion (and consequent partial change of state from liquid to gas) the temperature falls to 0° F. Theoretically about 18 per cent of the liquid is converted into gas in cooling the balance of the liquid to the refrigerator temperature, 0° F.

In ice making plants the liquefied ammonia is contained in coils of piping which are immersed in brine solution, this brine being caused to circulate through the piping system used for cooling the air or water. The brine being warmer than the ammonia causes the latter to boil (boiling point of ammonia is 29° F. below zero) and the resultant gas is returned to the compressor and condenser and re-liquefied, thus completing the cycle. Accordingly it may be noted that a refrigerating equipment consists essentially of (1) the compressor, (2) the condenser, and (3) the evaporator.

Refrigeration has assumed an especial industrial significance in the Gayley system (q. v.) for drying the air used in

blast furnace practice, aside from its specific function of producing low temperatures.

UTILIZATION OF ATMOSPHERIC NITROGEN

Nitrogen compounds constitute an essential factor in agricultural and in many technical industries. Germany annually consumes nitrogen in the form of its crude commercial compounds to the extent of 5.18 pounds per capita. The per capita consumption of the United States is little more than one-half that for Germany, but over \$32,000,000 is annually spent by the United States for importing nitrogen in its various combinations, over half of which goes to Chile for the purchase of Chile saltpeter (sodium nitrate).¹ Inasmuch as conservative opinion in Germany tends to regard the exhaustion of the Chilean beds now under development as certain within the next half century, the nitrogen problem is of a most serious character and in the quest of its solution a large amount of intensive research work has been undertaken.

The supply of nitrogen is in fact unlimited. If we take, for instance, the atmospheric nitrogen which is above 1 square mile of land, we shall find its weight to be about 20,000,000 tons which at the present rate of consumption would satisfy the entire world's requirements for the next 50 years. The difficulty which confronts us, however, is to bring it into a form available for the wants of mankind.

A very minute fraction of the atmospheric nitrogen is continually being utilized by the vegetable and animal kingdoms, where it passes through a series of transformations which constitute the "nitrogen cycle." By electric discharge a part of the nitrogen of the air is burned to nitric acid, as a nitrate in the soil it enters into plant life, becomes a part of the plant structure, passes into the bodies of animals, and is again re-

¹ An interesting non-technical account of nitrate mining in Chile will be found in Bryce's recent book on South America.

turned to the soil. These transformations are shown by Prof. P. H. Guye in the following diagram:

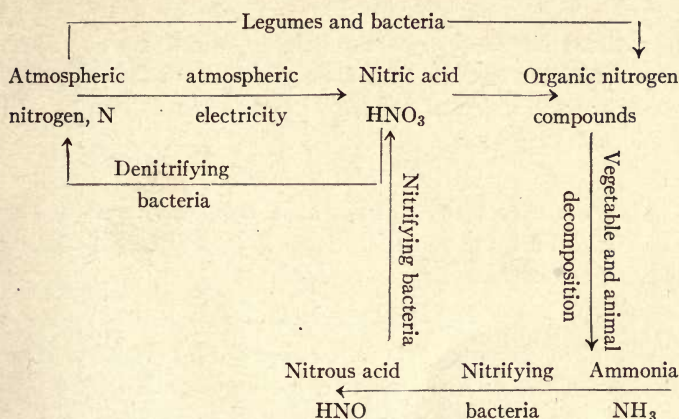

Aside from the fixation of nitrogen by the agents indicated in Prof. Guye's diagram, it will be necessary to rely upon industrial processes if atmospheric nitrogen is to be utilized in the formation of the various nitrogen compounds which are indispensable to modern industrial conditions.

The methods employed for the fixation of nitrogen are: (1) the direct oxidation of nitrogen of the air forming nitric acid, nitrates, etc.; (2) the synthesis of ammonia from nitrogen and hydrogen; (3) the fixation of nitrogen to metals forming nitrides; and (4) fixation by carbides forming cyanamide. Only a brief outline of these processes can be discussed here. For more complete historical accounts and descriptions of the apparatus used the student is referred to the bulletin (Special Agents' Series No. 52) issued by the Bureau of Manufactures, U. S. Department of Commerce and Labor, and to addresses delivered by Dr. Samuel Eyde and Dr. H. A. Bernthsen before the Eighth International Congress of Applied Chemistry in 1912. (*Transactions*, Vol. 28, pages 169-81, 182-202.)

The oxidation of nitrogen to nitric acid is accomplished by means of the apparatus of Birkeland and Eyde or that of Schoenherr. In both forms of apparatus a volume of air is introduced into a furnace or chamber, the flame of which consists of an electric arc. The principle underlying this process is the union of oxygen with nitrogen to form nitric oxide, a colorless gas:

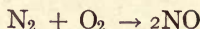

This gas leaves the furnace at a temperature of about 750° C. and it must be cooled down to 50° C. in order that it may be oxidized to nitrogen peroxide:

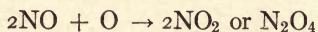

The nitrogen peroxide is next converted into nitric acid in absorption towers in which the current of gases passes upwards and meets a descending column of dilute nitric acid or water whereby the nitrogen peroxide is absorbed according to the reactions:

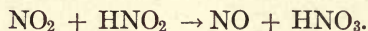
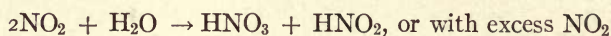

The liberated nitric oxide in the last equation in the presence of oxygen and water repeats the cycle of changes until finally all of the nitric oxide is changed to nitric acid.

The manufacture of nitric acid and its salts is carried on in Norway. It is dependent on cheap electric power generated by water power. The cost of such power in Norway is about \$3 per horse power year. The actual production of "air nitrate," as the nitrates manufactured from atmospheric nitrogen are called, shows the rapid growth of the new industry.

TABLE I.—Exports of Calcium Nitrate

| | |
|---------------|----------|
| 1905. | 115 tons |
| 1907. | 1,344 " |
| 1910. | 13,531 " |
| 1911. | 22,000 " |

The synthesis of ammonia has been recently worked out by Prof. Haber (German Patents 229126 and 238450) and the first factory is now (1912) under construction at Oppau, Germany. Two essential principles are involved in the union of nitrogen and hydrogen: (1) a pressure of from 175 to 200 atmospheres and (2) the presence of a catalytic agent, such as uranium.

In this process nitrogen is obtained, as above described, by the Claude or Linde process and can be produced at a cost of about 0.5 cent per pound. Hydrogen may be obtained as a by-product from electrolysis of solutions of common salt, or by passing steam over red hot iron, or by liquefying water gas (q. v.) in the Linde apparatus and separating the hydrogen from the carbon monoxide. The cost of production is about the same in the three methods mentioned and is sufficiently low to enable hydrogen to be used on a commercial scale for the manufacture of synthetic ammonia.

A third method for the fixation of atmospheric nitrogen is based upon its ready absorption by certain metals to form *nitrides*.

Of these aluminum nitride appears to offer the most promise and a plant capable of producing 30 tons of aluminum nitride daily has been erected in the Savoy district by a French company. The method employed in this plant was elaborated by Dr. Serpek and consists in treating in an electric revolving furnace, in an atmosphere of nitrogen, a charge of alumina, coal, and oxides of iron and calcium, the nitride being withdrawn from time to time at one end of the furnace. It is claimed by Serpek that, under the prevailing conditions of his process, alumina and aluminum carbide react first thus:

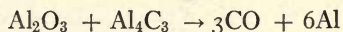

and the nascent aluminum then easily combines with nitrogen to form the nitride, AlN. The latter compound as pro-

duced in this process is a hard, bluish gray mass which slowly decomposes in moist air, giving off ammonia, and when boiled with water it gives off all its nitrogen as ammonia, the aluminum being changed to the hydroxide.

The production of calcium cyanamide is represented in the main by the reactions:

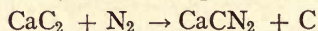
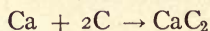
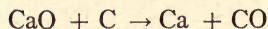

Its manufacture is carried on in relatively small drum-shaped ovens, each provided with a source of heat in its center derived from the electric current. A number of drums are filled with calcium carbide, which has been properly crushed so that the particles allow easy passage for the circulation of nitrogen and yet insure maximum conductivity of heat. The doors of the oven are then tightly closed and the electric terminals of the carbon resistance are connected with the current. The air in the ovens is displaced by nitrogen and the oven connected with a constant supply of nitrogen. After the current has been turned on and the resistance has transmitted heat to the surrounding layers of carbide to produce a temperature of 1100°C ., the reaction between the carbide and nitrogen takes place. This reaction is exothermic and the heat thus liberated is communicated to the inclosing carbide which is finally heated to the reaction temperature and more heat is liberated. The supply of electricity is therefore no longer required and the reaction proceeds to completion after its initiation in the center of the oven. It is necessary to maintain a rather delicate thermal balance within the oven, since at 1360°C . the reaction above given for the formation of calcium cyanamide is reversed and calcium carbide is regenerated. On the other hand if the temperature is allowed to fall below 1000°C ., the reaction is partial or fails completely.

Cyanamide works have been established in various countries at an expense of over \$15,000,000. More or less uncertainty prevails as to the quantity of cyanamide produced annually since it may either be converted into ammonia by superheated steam and thence into ammonium sulphate or it may be used directly as a fertilizer. The following list taken from the report of Thomas H. Norton (Special Agents' Series No. 52, U. S. Dept. of Commerce and Labor) represents an approximate annual productive capacity of calcium cyanamide works:

| | |
|---|-------------|
| Piano d'Orta, Italy. | 10,000 tons |
| Muhlthal, Germany. | 40,000 " |
| Trostberg, " | 60,000 " |
| Knapsack, " | 10,000 " |
| Spandau, " | 40,000 " |
| Notre Dame de Briancon, France. | 10,000 " |
| Martigny, Switzerland. | 10,000 " |
| Odde, Norway. | 12,000 " |
| Niagara Falls, Canada. | 10,000 " |
| Minaniata, Japan. | 40,000 " |
| <hr/> | |
| Total annual capacity. | 242,000 " |

REFERENCES

I

- BENEDICT: The Composition of the Atmosphere. (Published by the Carnegie Institution of Washington.)
- BERRY: The Atmosphere.
- CARPENTER: Heating and Ventilating Buildings.
- HARDIN: Liquefaction of Gases.
- HARRIS: Compressed Air and Computation.
- HISCOX: Compressed Air.
- LEASH: Refrigerating Machinery, its Principles and Management.
- STURTEVANT: Ventilation and Heating.
- TIEMANN: Principles of Drying Lumber, For. Ser. Bull. 104, U. S. Dept. of Agriculture.
- Transactions of American Society of Heating and Ventilating Engineers.

II

- RIX: Air in Mining. *Cassier*, **22**, 344 (1901).
- LINDE: Practical Possibilities of Liquid Air. *Cassier*, **24**, 139 (1904).
- BAKER: Filtration of Air. *Craftsman*, **8**, 521 (1905).
- MEIER: Sanitation of Air. *Pop. Sci. Monthly*, **70**, 19 (1908).
- HART: Dehydration of Air. *Cassier*, **34**, 122 (1908).
- FRERICHS: Purity of Commercial Liquefied Ammonia. *J. Ind. Eng. Chem.*, **1**, 362 (1909).
- BASKERVILLE: The Smoke Problem and the Community. *J. Ind. Eng. Chem.*, **2**, 355 (1910).
- BROWNE: Mechanical Purification of Air. *Cassier*, **38**, 564 (1910).
- SHÜCK: A New Process for Manufacture of Hydrogen from Water Gas. *Rev. Met.*, **7**, 1129 (1910); also *Chem. Abs.*, **5**, 1990 (1911).
- COTTRELL: Electrical Precipitation of Suspended Particles. *J. Ind. Eng. Chem.*, **3**, 542 (1911).
- DAUBINE AND ROY: Dessication of Air by Calcium Chloride. *Met. Chem. Eng.*, **9**, 343 (1911).
- GULICK: The Air We Breathe in Buildings. *Science*, **33**, 326 (1911).
- WINSLOW: Factory Sanitation and Efficiency. *J. Ind. Eng. Chem.*, **3**, 508 (1911).
- CHEW: Mechanical Refrigeration. *J. Inst. Brewing*, **18**, 274 (1912).
- BERNTHSEN: Synthetic Ammonia. *Transactions Eighth International Congress of Applied Chem.*, **28**, 182 (1912-13).
- EYDE: Oxidation of Atmospheric Nitrogen and Development of Resulting Industries in Norway. *Ibid.*, **28**, 169 (1912-13).
- DAVIS AND THOMPSON: The Conservation of the Atmosphere; The Use and Misuse of the Air—Legal Phases of Right to Air. *Original Communications, 8th Intern. Congr. Appl. Chem.*, **26**, 649 (1912-13).
- HILL AND FLACK: Physiological Influence of Ozone. *Proc. Royal Society, B*, **84**, 404 (1912).
- MUNROE: Physiological Effects of Carbon Monoxide. *School of Mines Quar.*, **33**, 340 (1912).
- SCHNECKENBERG: Physiological Experiments with Ozonized Air. *Gesundh. Ing.*, **35**, 965; *Chem. Abs.*, **7**, 1247 (1912-13).
- NICHOLAUS: Atmospheric Dust. *Rauch u. Stabu*, **3**, 132; *Chem. Abs.*, **7**, 1788 (1912-13).
- Report of Committee on Methods for Examination of Air. *Amer. Jour. Public Health*, **3**, 78 (1913).

CHAPTER III

INDUSTRIAL WATER

No attempt will be made in this chapter to discuss all the aspects of water supply either from the standpoint of sanitation or of the various specific industries in which water is an important factor. Water will be considered under three heads: (1) a brief consideration of some of the sanitary aspects, (2) water for steam generation, (3) water for irrigation.

SOME SANITARY RELATIONS OF WATER SUPPLY

Absolutely pure water is not found in nature and never enters into domestic or industrial use. Practically, water may be considered pure when it contains no disease-producing bacteria, nor an excess of foreign matter of any kind. A pure water supply is one of the most important safeguards of the health of any community whether it be a city, a country village, a factory, or a mining or lumbering camp. Of the specific diseases known to be transmitted by water, the most important are typhoid fever, dysentery, and Asiatic cholera. A pure water supply, however, has been found to improve the general health of the community and to decrease its death rate beyond the decrease due to the elimination of the specific diseases mentioned. This must mean either that diseases not ordinarily regarded as being carried by water are in a certain proportion of cases so transmitted, or that the use of a pure water supply so improves the general health that individuals become less susceptible to other diseases. It is probable that the latter explanation is the correct one and that the better

health due to a purer water supply has also a considerable influence in the direction of increased efficiency.

Water may be classified according to its source as:

- (1) Rain water (and melted snow),
- (2) Surface water (from rivers, streams, ponds, etc.),
- (3) Ground water (from springs and deep and shallow wells).

Evidently waters derived from such different sources are likely to differ in the impurities which they contain. From the sanitary standpoint the most important considerations are the possibilities of contamination with material which may carry injurious microorganisms. Next in importance are the dissolved organic and mineral matters, the solvent action of the water on lead, its hardness, and its physical properties such as color, clearness, coolness.

Rain water washes the air of its impurities, the nature of which has been discussed in the preceding chapter. Of principal importance in this connection are microorganisms, soot and dust, and the products of combustion and sometimes of decomposition of organic matter. If collected from roofs, additional matter may be present. The first portion of every shower should therefore be rejected. On account of the presence of these impurities, rain water is now not so highly prized as formerly. It is, however, free from any considerable degree of hardness, and hence is sometimes used for domestic purposes where the usual supply is too hard for washing, too alkaline for cooking, or too brackish for drinking.¹ Bacterial growth in rain water after storage may be very rapid on account of the food material often present. It should therefore be used in as fresh a condition as possible. Stored rain water may also become a breeding place for mosquitoes.

Surface water flows in streams and is collected in ponds, lakes, or impounding reservoirs. The character of a surface

¹ Water Supply Paper No. 255, U. S. Geol. Survey, p. 54.

water depends largely upon that of the surface over which it flows. If the surface consists of very insoluble material such as gneiss, or granite, the water will resemble rain water. Usually, however, the water, by direct solution or by decomposition of earthy material, takes up varying amounts of salts of calcium, magnesium, and sodium. It may also dissolve certain amounts of organic matter and carry both organic and inorganic materials in suspension. It is consequently frequently colored more or less noticeably and possesses a marked taste and, occasionally, a distinct odor. Usually surface waters are improved by storage in large reservoirs where sedimentation takes place, and by subsequent filtration. Since surface water is often exposed to pollution and may contain disease germs, sterilization by addition of bleaching powder or liquid chlorine or by boiling the water is also resorted to in many cases. See references at the end of the chapter.

Ground water may be obtained from springs, shallow wells, deep wells, and artesian wells. Spring water is highly esteemed for its purity, when found remote from dwellings, and is often found to possess some unusual value owing to the presence of a considerable amount of salts in solution, such waters being generally called "mineral waters." The term "mineral water," however, may be more accurately defined as a ground water which contains dissolved mineral matter unusual either in quantity or kind for the region in which it occurs. It is known commercially under two classes: (1) medicinal water, and (2) table water. Medicinal waters are those mineral waters which produce marked therapeutic action,—usually of a laxative or purgative character. Table waters are those mineral waters which for some markedly pleasing characteristic (carbon dioxide under pressure, sparkling clearness, etc.,) are especially palatable.

The water from shallow wells represents seepage water,

and when near human habitation is often found polluted even though in appearance it may be perfectly clean, and also palatable. Deep well water is obtained from wells sunk through an impervious layer into a water bearing stratum, or else sunk to great depth through permeable strata. As this water has usually travelled a considerable distance, the process of filtration and clarification is more nearly complete. Wells of this type often constitute the water supply of cities. Usually, however, supplies from this source are inadequate in quantity for the needs of an urban population. Any well in which the water rises under hydrostatic pressure is an artesian well. An artesian well from which the water issues at the surface is a flowing well.

The suitability of water for drinking is ordinarily determined by means of a "sanitary analysis," which may include bacteriological, chemical, microscopical, and physical studies.

In recent years methods for the detection in water of bacteria of the *B. coli* type (indicative of sewage pollution) have been greatly developed and simplified. Bacteriological examination is therefore much more practicable than formerly and rightly occupies an increasing prominent place in the sanitary examination of water supplies. A common method of conducting and reporting a bacteriological examination is to show what volume of water must be taken in order that the presence of bacteria of the *B. coli* type may be demonstrated, the volumes usually taken being 10 cc., 1 cc., and 0.1 cc. In very good water there may be no evidence of *B. coli* in 10 cc.; in badly contaminated water even 0.1 cc. may plainly show their presence.

In the chemical examination attention is directed particularly to the amount of chlorides and of each of the four forms of nitrogen—ammonia and its salts (reported as "free ammonia"), nitrogenous organic matter (reported as "albumenoid ammonia"), nitrites and nitrates. The results of a

chemical sanitary analysis are usually expressed in parts per million (milligrams per liter) or in grains per gallon.¹

Standard methods for the examination of water, including bacteriological, chemical, microscopical and physical tests and measurements, have been adopted and published by the American Public Health Association. The general adoption of such standard methods is especially desirable because of the fact that the judgment upon any given sample of water usually involves comparison with the analyses of other samples.

The interpretation of a water analysis is a matter of considerable difficulty requiring both good judgment and a knowledge of the character of the locality from which the water is obtained, and a careful study of comparable data. This subject is too complex for adequate discussion here; the student is referred to works on sanitary chemistry, sanitation and hygiene. The bibliography at the end of the chapter includes the titles of a few representative books in this field.

Water Purification.—Where no better supply of water is to be obtained, it is frequently necessary to use water which is polluted. In order to render such water fit for use, various processes are employed: (1) *impounding*; (2) *filtration*; and (3) *chemical treatment*. For discussion of these processes reference must be made to works on sanitary chemistry, sanitation, and hygiene.

WATER FOR STEAM GENERATION

The chief industrial difficulties caused by water in steam generation are *scale formation* in the boiler, the *corrosion* of the iron of the boiler, and the *foaming and priming* of the water during steam generation.

¹ To convert parts per million (p. p. m.) to grains per gallon multiply the former by .0584 (since one gallon contains 58,400 grains), and *vice versa* to convert grains per gallon to parts per million multiply the former by 17.12.

Scale Formation.—Scale is formed by the deposition of a sludge, or soft scale; of alkaline earth carbonates; of a hard adherent scale consisting of sulphate of calcium and magnesium; of hydroxide of magnesium; of silicious or aluminous matter, or of a combination of these; of a porous rubber-like scale from dirty oil; or by mixed deposits of the above nature.

The manner of scale formation is dependent in part upon the solubility of the various salts under the conditions of boiler service. An example of the effect of pressure and temperature upon the solubility of calcium sulphate is given in the following table taken from *Engineering* (Dec. 25, 1903) which shows that calcium sulphate is much less soluble in hot water than in cold.

TABLE 2.—Solubilities of Calcium Sulphate in Grains per Gallon (American)

| <i>Temperature degrees F.</i> | <i>Corresponding steam pressure pounds</i> | <i>Calcium sulphate grains per gallon</i> |
|-----------------------------------|--|---|
| 68 | ... | 140.6 |
| 212 | 0 | 125.9 |
| 284 | 37 | 45.6 |
| 323.6 | 79 | 32.7 |
| 356 | 131 | 15.7 |
| 464 | 484 | 10.5 |

The greater solubility of salts in water containing carbon dioxide and the corresponding reduction of solubility of the same salts at the boiling point of water are also important factors in causing deposition in the boiler. A few examples based in part upon data given in Harrison's *Purification of Water for Boiler Feeding* are quoted in Table 3:

TABLE 3.—Solubilities in Parts per Million

| <i>Substance</i> | <i>In water at 60° F.</i> | <i>In water containing carbon dioxide at 60° F.</i> | <i>In water at 212° F.</i> |
|------------------------|-------------------------------|---|--------------------------------|
| Calcium carbonate. . . | 12 | 1,100 | 21 |
| Calcium sulphate. . . | 2,010 | | 1,620 |
| Calcium oxide. | 1,290 | | 580 |
| Calcium hydroxide. . . | 1,700 | | 770 |
| Magnesium carbonate | 385 | 27,500 | nearly 0 |
| Magnesium oxide. . . | 7 | | nearly 0 |
| Magnesium hydroxide | nearly 0 | | nearly 0 |

The bad effects of boiler scale are: (1) its poor heat conductivity, (2) necessity of frequent cleaning of boilers, (3) decrease of efficiency and capacity due to the decrease in area of cross-section of inside of boiler tubes, thus reducing capacity and circulation, and (4) accidents caused by differences in the heat resistance of varying thicknesses of scale deposited on the boiler plate and softening and sagging of boiler plate through overheating due to presence of scale. The kind of scale has much to do with the effect on the boiler service. It has been found by Rankine that the heat resistance of dry calcium carbonate scale is 17 times as great as iron, and that of calcium sulphate scale, 48 times. This insulating effect of boiler scale requires an increased consumption of fuel. Experiments show that scale $\frac{1}{8}$ inch in thickness means a loss in heat transmission of 10 to 12 per cent and this reduction of efficiency increases as the square of the thickness of the scale.¹ The introduction of water softening plants (for prevention of

¹ Sames: Mechanical Engineers' Pocket Book.

scale) at 17 stations of the Chicago and Northwestern Railroad in 1903 effected a saving of 26 per cent in laborers (due to less work in cleaning and repairing), and reduced the boiler failures 79 per cent in a single year.

The method to be used for prevention of boiler scale depends upon the nature of the scale forming substances. The latter may be considered under two classes or heads: (1) "temporary hardness" caused by the bicarbonates of calcium, magnesium, and iron; and (2) "permanent hardness" caused chiefly by the sulphates of these elements.

Water Softening.—The temporary hardness of water may be removed by preheating or by precipitation with lime. Upon boiling for 20 to 30 minutes the bicarbonates are broken up as follows: $\text{CaH}_2(\text{CO}_3) \rightarrow \text{CaCO}_3 + \text{H}_2\text{O} + \text{CO}_2$. The objection to preheating is the length of time required for decomposition of the acid carbonates and the consequent expense. The reactions involved with the use of lime are

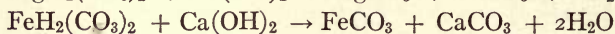
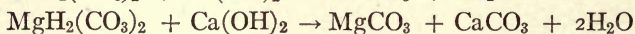
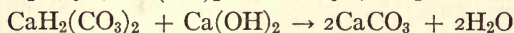
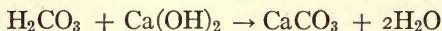

The estimation of the quantity of lime required for the precipitation of temporary hardness requires two factors in the analysis of a given water:

(1) Estimation of free carbon dioxide in water by titrating with standard sodium carbonate, using phenolphthalein as the indicator.

(2) Estimation of bicarbonates by titration with standard acid, using methyl orange as an indicator.

By calculating the results from these two determinations in terms of calcium carbonate, it is readily possible to ascertain the corresponding amount of lime which needs to be added for precipitation. For example, a given water contains 2 grains per gallon of free carbonic acid and 50 grains per

gallon in temporary hardness (calcium carbonate equivalent in both cases). To find the number of pounds of lime required per 1000 gallons of water, we make use of the following calculation:

$$\text{CaO} : \text{CaCO}_3 :: x : 52.$$

$$56 : 100 :: ? \text{ grains} : 52.$$

$$x = 29.12 \text{ grains of CaO per gallon.}$$

or in pounds of lime per 1000 gallons of water

$$\frac{1000}{7000} \times 29.12 = 4.15 \text{ pounds.}$$

The solubility of lime at 60° F. is 75 grains per gallon;

hence $\frac{7000}{75}$ = the number of gallons of water necessary to

hold one pound of lime in solution. Hence $\frac{7000}{75} \times 4.15$, or

387.3, represents the number of gallons of saturated lime water necessary to soften 1000 gallons of the water cited. In actual practice additional lime is added in case the water contains much magnesium so as to convert the magnesium carbonate into the hydroxide form (see solubility table above). Lime is also frequently furnished in its hydrated form as a very fine dry powder. To determine the quantity of this reagent it is necessary to substitute its formula $\text{Ca}(\text{OH})_2$ and its solubility (in grains per gallon) factor, 99, for the figures used in the case of lime.

Permanent or sulphate hardness may be corrected by the use of sodium carbonate usually in the commercial form of "soda ash" (containing 58 per cent Na_2O). The reactions here involved are

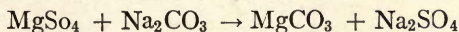
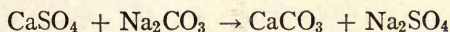

To ascertain the amount of reagent necessary, the results from the determination of permanent hardness must be

used. "French degrees" express the hardness due to sulphates in parts of calcium carbonate per 100,000 parts of water. When these degrees are multiplied by 0.584, we get the hardness expressed in grains of calcium carbonate per gallon. Hence the grains per gallon of sodium carbonate required may be found by the ratio existing between the molecular weights of sodium carbonate and calcium carbonate. For example, in a water containing 14 degrees (French, q. v.) of permanent hardness, we have the following calculations:

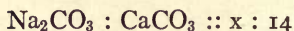

$$106 : 100 :: x : 14$$

$$x = 14.8 \text{ parts of Na}_2\text{CO}_3$$

$$14.8 \times 0.584 = 8.64 \text{ grains of Na}_2\text{CO}_3 \text{ per gallon or}$$

$$\frac{1000}{7000} \times 8.64 = 1.2 \text{ lbs. of Na}_2\text{CO}_3 \text{ per 1000 gallons of water.}$$

Water softening plants, while based upon the theories just explained, generally combine the removal of temporary and permanent hardness in one operation.¹ This is done by adding to the lime the requisite amount of soda ash and admitting automatically measured quantities of the combined reagents.

"Boiler compounds" usually consist of soda ash and one or more other constituents (sometimes inert). When tan bark is used with soda ash the tannin is believed to help by preventing the deposit from sticking to the iron.

Corrosion.—Corrosion attacks the iron of the boiler either in pittings (localized action) or over a large surface. Its effect is to oxidize or rust the iron causing either an inequality in the thickness of the plate, or a decrease in strength, or both.

¹ See *Cassier's Magazine*, 31, 416 (1907), on "The Present Status of the Art of Water Softening."

Corrosion is now believed to be caused by electrolytic action aided by

- (1) acidity of the water;
 - (a) mineral acidity (carbonic acid, etc.);
 - (b) organic acidity (hydrolysis of oils, etc.);
- (2) depolarizing action of dissolved oxygen;
- (3) internal potential differences in metal of the boiler.

The acidity of water may be due to the presence of carbon dioxide or organic acids. Water from coal mines often contains acids formed from the oxidation of sulphur in the coal. The temperature and pressure of the boiler are also favorable to the formation of acids due to the hydrolysis of certain salts. Thus magnesium chloride ¹ is a frequent constituent of boiler water, and under boiler conditions its partial hydrolysis results in a series of reactions, according to De Coux, as follows:

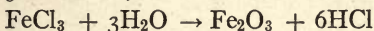
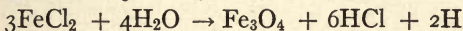
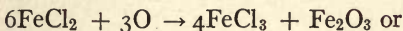
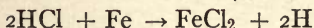
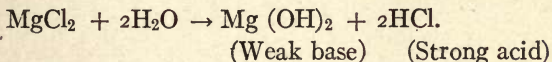

Fatty oils used in lubrication or introduced through sewage matter are hydrolyzed by steam and free acids are generated, which act on iron similarly to mineral acids though the fatty acids, are of course, very much weaker than most mineral acids.

The work of Cushman,² and of Burgess³ and others has shown that pitting is often caused by galvanic cur-

¹ Corrosion of Boilers by Magnesium Chloride. *Engineering*, 74, 482 (1902).

² Corrosion and Preservation of Iron and Steel (1910).

³ *J. Western Soc. Eng.*, 14, 375 (1909).

rents produced by internal potential differences in the metal. This action is due to the setting up of electrolytic couples between parts of the boiler representing different metallic compositions or different heat treatments of the same iron.

Dissolved air is much richer in oxygen than atmospheric air, due to the difference in the solubility of oxygen and nitrogen in water. This dissolved oxygen aids materially in promoting the electrolytic action by acting as a depolarizer at the cathode, thereby facilitating the flow of the current. After the oxygen in the water has been removed, the electrolytic action decreases. The remedies for corrosion are: (1) the neutralization of the acids; (2) preheating the water to remove gases; (3) metallic zinc, which is acted upon by electrolytic currents and thus saves the iron from attack, and (4) the use in lubrication of mineral oils which do not yield acids as do the fatty oils.

Foaming and Priming.—*Foaming* is the filling up of the steam space with unbroken bubbles of steam and *priming* occurs when the steam carries water with it from the boiler. Foaming is a surface condition which may be produced by suspended impurities rising to the surface and forming a scum, or it may be caused by the concentration of salts becoming so great as to increase the surface tension of the film of water surrounding the bubbles, thus preventing them from breaking. Besides the impurities in the water the operation of the boiler and engine and the structure of the boiler are in part responsible for foaming. The impurities in water giving rise to foaming are salts of the alkalis, soaps, and organic matter as in swamp waters. In practice when salts such as chlorides, sulphates or carbonates reach a concentration of 100 grains to the gallon, foaming is apt to occur. The remedy is to blow off the boiler at intervals.

The industrial difficulties encountered in the use of boiler water may be summarized as follows:

| <i>Trouble</i> | <i>Cause</i> | <i>Remedy</i> |
|-----------------|---|---|
| Scale Formation | Sediment, mud, clay | Filtration. |
| | Bicarbonates of lime, iron and magnesium | Preheating and precipitation with lime or sodium carbonate. |
| | Organic matter | Precipitation with alum and filtration. |
| | Sulphate of lime | Precipitation with soda ash. |
| Corrosion | Organic matter | Removal as above or by neutralization with soda ash. |
| | Grease | Soda ash and filtration. |
| | Chloride or sulphate of magnesium | Soda ash. |
| | Acids | Soda ash. |
| | Dissolved carbon dioxide and oxygen | Preheating or soda ash. |
| | Electrolytic action | Zinc plate. |
| Priming | Sewage | Precipitation with alum and filtration. |
| | Alkalies | Blowing off. |

STANDARDS OF PURITY FOR BOILER WATERS

A 200 horse power boiler running day and night for one week evaporates 1,008,000 pounds of water. The analysis ¹ of a certain water used in such a boiler is as follows:

| | <i>Grains per gallon</i> |
|--------------------------|----------------------------------|
| Calcium carbonate..... | 39.16 |
| Calcium sulphate..... | 9.30 |
| Magnesium carbonate..... | 5.05 |
| Magnesium sulphate..... | 3.75 |
| Total..... | 57.26 |

The sediment and scale deposited at the end of the week's run would be 989 pounds, spread over perhaps 2000 square feet of heating surface. In a recent work on steam power plants, Prof. Gebhardt gives a number of ratings and results to aid in forming a conclusion regarding the suitability of a given water for boiler purposes. These tables are given below:

Rating for Water Containing Temporary Hardness (Gebhardt)

| | |
|--------------------|-----------|
| Less than 8 grains | Very good |
| 12 to 15 | Good |
| 15 to 20 | Fair |
| 20 to 30 | Bad |
| Over 30 | Very bad |

In the case of permanent hardness these quantities should be divided by four to obtain the same ratings.

Analyses for Comparison.—The same author reports a number of analyses of scale, and of the water forming the scale, which may be helpful for purposes of comparison (Tables 4 and 5):

¹ Cochrane: Engineering Leaflet, No. 12, p. 6.

TABLE 4.—Water and Boiler Scale Analyses

| <i>Water analysis grains per gallon (American)</i> | <i>Lake Mich- igan</i> | <i>Well 115 feet deep Ohio</i> | <i>San Fran- cisco</i> | <i>Park City, Utah</i> | <i>Ke- wanee, Ill.</i> | <i>Arkan- sas River, Colo- rado</i> |
|--|--------------------------------|--|--------------------------------|--------------------------------|--------------------------------|---|
| | 1 | 2 | 3 | 4 | 5 | 6 |
| Silica..... | 0.438 | 0.677 | 0.759 | 1.354 | 0.373 | 0.630 |
| Oxide of iron and aluminum..... | 0.099 | 0.116 | 0.116 | .350 | 0.081 | 0.075 |
| Carbonate of lime.... | 3.731 | 2.271 | 4.207 | 1.476 | 1.721 | 2.158 |
| Sulphate of lime..... | 0.962 | 4.083 | 0.680 | 1.360 | 1.360 | 18.540 |
| Carbonate of magnesia | 2.092 | 4.424 | 2.866 | 0.318 | 2.212 | 4.848 |
| Sodium and potassium sulphates..... | Trace | Trace | 1.681 | 0.867 | 12.928 | 11.319 |
| Sodium and potassium chlorides..... | 0.670 | 0.990 | 2.970 | 1.980 | 26.070 | 2.028 |
| Organic matter..... | 0.066 | 0.584 | | 2.569 | 0.584 | 0.701 |
| Total mineral matter.. | 8.058 | 12.614 | 13.665 | 7.826 | 45.318 | 40.062 |

TABLE 5.—Analyses of Scale from Water

| <i>Character of sample</i> | 1 | 2 | 3 | 4 | 5 | 6 |
|--|----------------------|------------------------|----------------------|------------------|----------------------|--------------------------|
| | <i>Hard, brittle</i> | <i>Medium hardness</i> | <i>Hard, brittle</i> | <i>Very hard</i> | <i>Soft, brittle</i> | <i>Hard, crystalline</i> |
| Silica.....p. ct. | 20.60 | 8.44 | 11.18 | 19.00 | 2.52 | 6.20 |
| Oxide of iron and alu- minum..... " | 10.30 | 1.30 | 10.44 | 6.26 | 4.92 | 2.36 |
| Carbonate of lime.... " | 33.86 | 37.22 | 40.96 | 29.02 | 18.18 | 18.78 |
| Sulphate of lime..... " | None | 33.82 | Trace | 5.48 | 54.76 | 59.84 |
| Carbonate of magnesia " | 6.04 | Trace | 22.60 | Trace | Trace | 0.84 |
| Magnesia (MgO).... " | 15.48 | 12.01 | | 1.45 | 9.08 | 4.75 |
| Moisture and organic matter..... " | 12.89 | 6.22 | 13.58 | 13.69 | 7.40 | 5.73 |
| Oil..... " | Trace | | | | 2.92 | |
| Loss and undetermined " | 0.83 | 0.99 | 1.24 | 1.55 | 0.22 | 1.50 |

From a comparison of the analyses of the water and scale respectively, the following statements may be made in regard to the waters from the six sources considered.

(1) This water will cause the deposit of a moderate amount of scale which will be hard and persistent.

(2) This water will cause a large amount of scale to deposit.

(3) This water will cause a moderate amount of scale with a decided tendency to galvanic action on account of the large proportion of sodium and potassium salts present.

(4) This water will cause the formation of some scale. There is also a decided tendency to corrosive action.

(5) Will cause formation of some incrustation of medium hardness. It will also cause considerable trouble due to galvanic action, foaming and priming.

(6) This is not a desirable feed water. It will cause the formation of considerable scale and will cause corrosion, pitting, and possibly foaming.

WATER FOR USE IN IRRIGATION

The chief factor in water to be used in irrigation is the presence of mineral salts in large quantity. It is well known that soils containing an excessive quantity of alkaline salts, such as sodium carbonate, sodium chloride, and sodium sulphate, are not capable of being used for crops. Consequently the water used in the irrigation of soils should not augment the so-called "alkali" content of the soil. The "alkali" referred to may be either "black alkali," which is sodium carbonate, or "white alkali," which may be a mixture of chlorides and sulphates of sodium, calcium, and magnesium. The adaptability of water for irrigation purposes has been made the subject of study by the soil chemists, who have proposed certain arbitrary standards. Hilgard¹ states that 1500

¹ Hilgard: Soils, p. 467.

pounds of sodium per acre (i. e., per 16,000,000 pounds of soil) in combination with radicals which give it about the same toxicity as sodium sulphate, is not injurious to the average crops. On this basis Stabler¹ has worked out an "alkali coefficient," which may serve as a basis for the classification of waters used in irrigation. According to these standards any water which contains salts to the extent of 400 parts of sodium per million is rated as poor and should not be used for irrigation unless care is exercised in the selection of crops or in providing good drainage.

REFERENCES

I

- AMERICAN PUBLIC HEALTH ASSOCIATION: Standard Methods of Analysis.
BAKER: Municipal Engineering and Sanitation.
BARTOW AND JACOBSEN: Analytical Control of Water Softening. Univ. of Ill. Water Survey Bull. 8, 88.
BOOTH: Water Softening.
CHAPIN: Municipal Sanitation in the United States.
CHRISTIE: Boiler Waters.
CHRISTIE: Water, its Purification and Use in the Industries.
DE LA COUX: Industrial Uses of Water.
FRIEND: Corrosion of Iron and Steel. U. S. Geol. Survey Bull. 479.
FUERTES: Water Filtration Works.
FULLER: Sewage Disposal.
FULLER: Underground Waters for Farm Use. U. S. Geol. Survey, Water Supply Paper No. 255.
HAZEN: Clean Water and How to Get It.
HAZEN: The Filtration of Public Water Supplies.
HOOKER: Chloride of Lime in Sanitation.
JOHNSON: Sterilization of Public Water Supplies.
JORDAN: The Self-Purification of Streams.
KINNICUTT, WINSLOW AND PRATT: Sewage Disposal.
MASON: Examination of Water.
OGDEN AND CLEVELAND: Practical Methods of Sewage Disposal.

¹ U. S. Geol. Survey, Water Supply Paper 274, Part II, The Industrial Application of Water Analysis.

- PHELPS: Disinfection of Sewage. U. S. Geol. Survey, Water Supply Paper No. 229.
 RAFTER: Sewage Irrigation, U. S. Geol. Survey.
 RICHARDS: Conservation Through Sanitation.
 RICHARDS AND WOODMAN: Air, Water and Food.
 STABLER: Some Surface Waters of the Western Part of the United States. Part 2. Interpretation of Water Analysis. U. S. Geol. Survey. Water Supply Paper, No. 274.
 TURNEAURE AND RUSSELL: Water Supply.
 VAN BRUNT: The Action of Bleaching Powder in Water Purification, Univ. of Ill. Bulletin No. 23, 8, 51 (1911).
 WHIPPLE: The Microscopy of Drinking Water.
 WHIPPLE: Value of Pure Water.

II

- EDGAR: Physical and Chemical Properties of Oils in Boilers. *W. Electr.*, 22, 63 (1898).
 STILLMAN: The Clark Process of Water Softening. *Trans. Am. Soc. Mech. Eng.*, 19, 415 (1898).
 DOUGLASS: The Use of Zinc in Boilers. *Am. Electr.*, 13, 572 (1901).
 RIDENOUR: The Chemistry of Deposits in Steam Boilers. *J. Frank. Inst.*, 152, 113 (1901).
 Review of Four Systems of Softening Water. *Eng. News*, 50, 4 (1903).
 BOOTH: The Use of Boiler Compounds. *Eng. News*, 54, 102 (1905).
 MOORE AND KELLERMAN: Copper as an Algicide and Disinfectant in Water Supplies. U. S. Dept. Agriculture, Bur. Plant Industry, Bull. 76 (1905).
 KINNICUTT: The Sanitary Value of a Water Analysis. *Proc. Am. Ass. Adv. Sci.*, 55, 297 (1906).
 KRITZKOW: Present Status of the Disposal of Sulphite Liquor in Germany. *Eng. Rec.* 62, 468 (1910).
 BLACHER: Study of Humus Substances. *Chem. Ztg.*, 34, 1314 (1910); also *Chem. Abs.*, 5, 1647, 2288 (1911).
 DUNN: Electrolytic Treatment of Sewage at Santa Monica. *Tech. World*, 14, 341 (1910).
 HERING: The Imhoff Sewage Clarification Tank. *Eng. News*, 64, 604 (1910).
 JOHNSON: Sewage Treatment to Prevent River Pollution. *Eng. Rec.*, 61, 324 (1910).
 IMHOFF: A New Method of Handling Sewage Sludge. *Eng. Rec.*, 62, 673 (1910).

- WALDEN AND POWELL: Sterilization of Water. *Am. Water Works Assoc.*, 1910, 128; *Chem. Abs.*, 5, 1139, 2516 (1911).
- BARTOW AND JACOBSON: Water Softening. Univ. of Ill. State Water Survey, Bull. 8, 88 (1911).
- BARTOW AND MARTI: Treatment of Water with Boiler Compounds. Univ. of Ill. State Water Survey, Bull. 8, 59 (1911).
- BLACHER: Purification of Water by Ozone. *Chem. News*, 103, 38 (1911).
- BOOTH: Boiler Water Purification. *J. Ind. Eng. Chem.*, 3, 326 (1911).
- ELLS: Disintegration of Concrete in Sewage Disposal Tanks. *Eng. Rec.*, 63, 418 (1911).
- ELLS: Effect of Bleaching Powder on Bacterial Life in Water. *Eng. Rec.*, 63, 471 (1911).
- FULLER: Sedimentation in an Experimental Imhoff Tank. *Eng. Rec.*, 63, 537 (1911).
- FULLER: Sewage Disposal with Respect to Offensive Odors. *Eng. Rec.*, 63, 408 (1911).
- CLARK AND GAGE: Corrosive Action of Water before and after Purification. *Eng. Rec.*, 64, 504 (1911).
- HUNGERFORD: Water Filtration for Industrial Purposes. *J. Frank. Inst.*, 171, 261 (1911).
- JACOBSON: Analytical Control of Water Softening. *J. Inst. Brewing*, 8, 88 (1911).
- JOHNSON: Hypochlorite Treatment of Public Water Supplies, its Adaptability and Limitations. *J. Am. Pub. Health Assn.*, 1, 562 (1911).
- MASS. BOARD OF HEALTH: Condition of an Intermittent Sand Filter for Sewage after 23 years Operation. *Eng. Contr.*, 37, 271 (1911).
- STABLER: Electrolytic Purification of Water and Sewage at Oklahoma City. *Elect. World*, 57, 1099 (1911).
- Camp Sanitation in the State of Washington. *Eng. Contr.*, 37, 668 (1911).
- FRANCIS: Locomotive Boiler Corrosion and Treated Water. *American Ry. Assoc.*, 13, 420 (1912).
- HANSEN: Limitation of Stream Pollution. Ill. Water Supply Assn., 1912, 41.
- HARDMAN: Camp Sanitation. *Eng. News*, 68, 714 (1912).
- HAZEN: Progress in Developing and Conserving Water Supply for Municipal and Domestic Purposes. *Original Communications, 8th Intern. Congr. Appl. Chem.*, 24, 115 (1912).
- HERING AND LEDERER: Standard Tests for the Efficiency of Sewage Treatment. *Eng. News*, 68, 589 (1912).
- JENNINGS: What Hypochlorite Accomplishes. *Original Communications, 8th Intern. Congr. Appl. Chem.*, 26, 215; *Eng. News*, 68, 1109 (1912).

- LEDERER AND BACHMAN: Disinfecting Lake Water with Calcium Hypochlorite. *Eng. Rec.*, **65**, 360 (1912).
- PHELPS: The Chemical Disinfection of Sewage. *Am. J. Pub. Health*, **2**, 72 (1912).
- SWETZ: New Methods of Water Purification for City Supply. *Chem. Abs.*, **6**, 1792 (1912).
- WALKER: The Relative Corrosion of Iron and Steel Pipe as Found in Service. *J. N. E. Waterworks Assoc.*, No. 1, **26**, 7 (1912).
- Water Softening Plant for 10,000 Gallons per Hour. *Engineering*, **93**, 661 (1912).
- Waterworks Statistics of American Cities. *Municipal Journal*, **32**, 949 (1912).
- WHIPPLE: Report of Committee on Standards of Purity for Rivers and Waterways. *Eng. Rec.*, **66**, 485 (1912).
- WOLFF: Magnesium Chloride in Boiler Waters. *Ztschr. f. Dampfkessel u. Masch.-betrieb.*, **34**, 333; *Chem. Abs.*, **6**, 2662 (1912).
- PRATT: Uses and Abuses of Water Filtration. *J. N. E. Waterworks Assn.*, **26**, 341 (1913).
- WHIPPLE: Sanitary Protection of the Water Supplies taken from the Great Lakes. *Original Communications, 8th Intern. Congr. Appl. Chem.*, **26**, 271 (1912-13).
- KEMP: The Ground Waters. *Bull. Am. Inst. Mining Eng.*, **76**, 603 (1913).
- WHERRY AND CHILES: New Light on the Chemistry of Boiler Scale Prevention. *Eng. Mag.* **45**, 518 (1913).

CHAPTER IV

COMBUSTION AND DESTRUCTIVE DISTILLATION

COMBUSTION

COMBUSTION in the widest sense is rapid chemical action where there is sensible change of temperature and a production of light.¹ From the industrial standpoint interest in combustion is practically limited to chemical actions involving oxygen as one of the factors, while the other factor (fuel) is ordinarily carbon, hydrogen, sulphur or one or more of the many compounds of these elements. Combustion may be partial, as in the production of carbon monoxide from carbonaceous fuel, or complete, as in the production of carbon dioxide.

In order to initiate a combustion the reacting materials must be brought into contact in such a manner that their rate of union produces heat as rapidly or more rapidly than it is dissipated by convection, conduction or radiation. When this is done, the heat evolved maintains a rapid reaction as long as the reacting materials are furnished in adequate quantities.

The rate of reaction between given materials is affected by temperature, concentration and catalytic agents, and the most usual method of increasing the speed of union to the point of self-maintenance (the kindling temperature) is by increase of temperature. The kindling temperature

¹ In some cases the production of light is so slight that the combustion is said to occur "with a colorless flame."

of the more common fuels is indicated in the following table: ¹

| | | | | | |
|-----------------|------------------|----------------|-------------|--------------|----|
| Lignite dust | kindles at about | 300° | F. or about | 150° | C. |
| Dry peat | “ “ | 435° | “ “ | 225° | “ |
| Bituminous coal | “ “ | 660° | “ “ | 315° | “ |
| Anthracite coal | “ “ | 750° | “ “ | 400° | “ |
| Coke | “ “ | 800° | “ “ | 425° | “ |
| Hydrogen | “ “ | 1030° to 1290° | “ “ | 555° to 700° | “ |
| Carbon monoxide | “ “ | 1200° | “ “ | 650° | “ |

Any substance which unites with oxygen in such a manner as to produce combustion may be termed “combustible,” while oxygen is considered as the “supporter of combustion.”

The economic value of a fuel undergoing combustion involves two distinct factors: (1) the quantity of heat produced, and (2) its intensity.

The amount of heat produced by fuels varies greatly and its measurement is of fundamental importance. It is expressed in either of two forms, as British thermal units (B. t. u.) per pound or in calories per gram (or Calories per kilogram). In industrial work the unit usually employed is the British thermal unit, which is the amount of heat required to raise the temperature of one pound of water from 60° F. to 61° F. In scientific work it is more usual to express quantity of heat in calories. A calorie is the amount of heat required to raise the temperature of 1 gram of water from 15° C. to 16° C. A Calorie (or “greater calorie”) is 1000 times this amount. A calorie per gram (or a Calorie per kilogram) is therefore equivalent to 1.8 B. t. u. per pound.

The temperature of combustion (the calorific intensity) depends not only upon the quantity of heat liberated but upon the heat capacity of the products resulting from combustion. It is measured in degrees using the Fahrenheit or Centigrade scale by various kinds of thermometers and pyrometers. Thermometers are in common use and, as is well known, their construction is based upon the dilation of liquids or gases as

¹ Stromeier: Marine Boiler Management, p. 93.

measured within a graduated capillary tube. Mercury is mostly employed for measurements of the lower temperatures. When the space above the mercury is filled with an inert gas such as nitrogen or carbon dioxide, the mercury thermometer may be used to record temperatures as high as 500° C. For low temperatures, as in freezing mixtures, liquids like alcohol and toluene are employed. In ceramic work the Seger cones are conveniently used. They consist of artificial mixtures of silicates and fluxes and are so constituted that mixtures of a given composition will fuse and lose their conical or pyramidal shape at a given temperature. Hence by using a series of these cones, and noting their shape, after subjection to the heat, the temperature of a furnace may be readily ascertained. The platinum resistance and thermoelectric thermometers measure temperatures by means of a flow of the electric current sent through, or generated by, the system. For temperatures above the fusing point of platinum, the optical pyrometer is used. In the latter, use is made of a small telescope containing a quartz plate between two Nicol prisms. Looking at a heated body, one of the prisms is turned until the red color changes to yellow, then green, and lastly blue. The angle of rotation is then used as the basis of the temperature calculations.

Temperature is sometimes estimated by the color imparted to various bodies. According to Pouillet the colors of brick fire-boxes correspond to the following temperatures:

| | |
|--------------------------------|----------|
| First visible red. | 525° C. |
| Dull red. | 700° C. |
| Turning to cherry red. | 800° C. |
| Cherry proper. | 900° C. |
| Bright cherry. | 1000° C. |
| Dark yellow. | 1100° C. |
| Bright yellow. | 1200° C. |
| White glow. | 1300° C. |
| Bright white. | 1400° C. |
| Dazzling white. | 1500° C. |

Obviously much experience must be necessary before temperature can be judged in this way with any considerable degree of accuracy.

Determination of Calorific Power.—The heat of combustion may be (1) determined from the temperature produced by the combustion of a weighed quantity of fuel in a calorimeter of known heat capacity, or (2) it may be computed approximately from the results of a chemical analysis of the fuel as will be explained below.

The calorimeters used for the determination of the heat of combustion (calorific power) of a fuel may vary greatly in construction and manner of manipulation, but in general they consist of strong metallic bombs equipped with the necessary means for supplying oxygen under pressure and with a means for firing the fuel. The heat of combustion is radiated to a bath of water in which the bomb is immersed and the increase of temperature of the latter is noted.¹ Each calorimeter must be properly calibrated or standardized² so that the heat capacity of the apparatus may be known. This is usually expressed as its "water equivalent." An example may make the description clearer:

| | |
|--|------------------|
| Weight of sample. | 1 gram. |
| Final thermometer reading. | 26.463° |
| Initial thermometer reading. | 23.897° |
| Observed temperature change. | 2.566° |
| Corrected temperature change. | 2.5706° |
| Water equivalent (grams of water). | 3000 |
| Total heat developed (calories). | 7711.8 |
| Correction for wire, nitrogen, sulphur. | 41.4 |
| Heat developed by combustion of 1 gram sample. | 7670.4 calories. |

¹ For descriptions of bomb calorimeters see Atwater and Snell (*Jour. Amer. Chem. Soc.*, July, 1903), Emerson (*Jour. Ind. and Eng. Chem.*, Jan., 1909), Gill (*Gas and Fuel Analysis for Engineers*) and other works cited at the end of the chapter.

² Circular No. 11, U. S. Bureau of Standards: The Standardization of Bomb Calorimeters (1911).

The heat of combustion of the substance is therefore 7670 calories per gram or $(7670 \times 1.8 =)$ 13,800 B. t. u. per pound.

The theoretical temperature of combustion can be calculated from the calorific power of the fuel and the heat capacity of the products of combustion and of the residual substances. This rule for calculating the calorific intensity of a substance is as follows: "Divide its calorific power by the sum of the weights of the products of combustion and of the residual substances multiplied by their respective specific heats." Thus if it is desired to calculate the temperature produced when carbon is burned in oxygen the following data must be used:

Calorific power of carbon, 8080 calories per gram.

Weight of carbon dioxide from combustion, 3.67 grams.

Specific heat of carbon dioxide, 0.2163; hence the calorific intensity:

$$C = \frac{8080}{\text{c. i. } 3.67 \times 0.2163} = 10178^{\circ} \text{ C.}$$

In the case of the combustion of hydrogen in oxygen, the product, H_2O , may be either a liquid or a gas, depending upon the temperature. To maintain it in a gaseous condition requires the following quantity of heat: Latent heat of steam of 9 grams of water (9×537), 4,833 calories. Heat loss due to the difference between the specific heats of water and steam,

or

$$100 \times 9 (1 - 0.4805) = 467.55 \text{ calories, hence}$$

$$H = \frac{34462 - (4833 + 467.55)}{\text{c. i. } 9 \times 0.4805} = 6743.5^{\circ} \text{ C.}$$

or when burned in air

$$H = \frac{29161.45}{\text{c. i. } (9 \times 0.4805) + (26.8 \times 0.244)} = 2659.8^{\circ} \text{ C.}$$

where 0.244 equals the specific heat of nitrogen and 26.8 equals the weight of nitrogen in the air containing 8 grams of

oxygen. When excess air is used as is always the case in practice, the theoretical temperature cannot be obtained. (See Table 7.)

THE ELEMENTS OF COMBUSTION

Oxygen is the supporter of combustion and generally is supplied as a constituent of the air. In a few cases the oxygen combined with other elements may be utilized for combustion as in thermite (q. v.). When oxygen is a constituent of an ordinary fuel it decreases the calorific power of the fuel, inasmuch as the elements comprising such a fuel are already partially oxidized.

Nitrogen is not directly related to combustion but is of importance on account of the effect which it produces. As a constituent of the air it acts as a diluent of the oxygen, absorbs heat, and accordingly serves as an additional carrier for heat lost in the chimney gases or gaseous products of combustion.

Carbon is the most common constituent of combustibles. Carbon and its compounds constitute a very large part of all the ordinary fuels. The usual ways in which carbon enters into reaction in the burning of ordinary fuels may be expressed in part by the following:

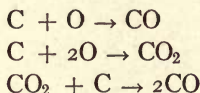

In practice, however, the fuel is only in exceptional cases free carbon; more often it is a mixture of compounds of carbon with hydrogen or hydrogen and oxygen. The calorific power of carbon burned to carbon dioxide is 8080 calories per gram or 14,544 B. t. u. per pound.

Hydrogen is usually combined with carbon in combustibles and is one of the active constituents in combustion. The

product of the combustion of hydrogen is water. Its calorific value is 34,500 calories per gram or 62,100 B. t. u. per pound.

Sulphur, which is often found combined with other elements in fuel, during the process of combustion is oxidized to sulphur dioxide. The calorific power of sulphur burned to sulphur dioxide is 2250 calories per gram or 4050 B. t. u. per pound. On account of the corrosive character of sulphur dioxide in aqueous solutions (condensations of steam in smokestacks) it is regarded as an objectionable constituent in fuel.

The following table taken from *Power*, 25, 66 (1908) summarizes the essential combustion data of the active elements entering into combustion:

TABLE 6.—Combustion Data

| Chemical reaction | 1 | 2 | 3 | 4 | 5 |
|---------------------------|---------------------------------|------------------------------|----------------------------------|-----------------------------------|------------------------------------|
| | Pounds oxygen per pound of fuel | Pounds air per pound of fuel | Cubic feet air per pound of fuel | Pounds nitrogen per pound of fuel | Gaseous products per pound of fuel |
| $C + O \rightarrow CO$ | 1.33 | 5.79 | 76.10 | 4.46 | 6.79 |
| $C + 2O \rightarrow CO_2$ | 2.66 | 11.59 | 152.29 | 8.92 | 12.59 |
| $CO + O \rightarrow CO_2$ | 0.57 | 2.48 | 32.58 | 1.91 | 3.48 |
| $2H + O \rightarrow H_2O$ | 8.0 | 34.78 | 457.00 | 26.78 | 35.78 |
| $S + 2O \rightarrow SO_2$ | 1.0 | 4.35 | 57.16 | 3.35 | 5.35 |

In this table the figures in column 1 represent the parts by weight of pure oxygen theoretically necessary to oxidize one part by weight of each of the fuels; the figures in column 2 are found by dividing the corresponding values in column 1 by .23, the fraction of a pound of oxygen contained in a

pound of air; column 3, by multiplying the corresponding value in column 2 by 13.14, the cubic feet (under standard conditions) per pound of air; column 4, by subtracting corresponding values of column 1 from those of column 2; and column 5, by adding corresponding values in column 2 to the weight of the fuel itself.

EFFICIENCY OF COMBUSTION

The process of combustion up to this point has been considered as taking place under ideal conditions. In actual practice it is impracticable either to attain the theoretical temperature or to utilize the maximum calorific power of a given fuel. The causes that impair the efficiency of combustion are *excess air*, *heat losses*, and *insufficient air to ensure complete combustion*.

Excess air lowers the temperature of combustion and serves as a vehicle for the conduction of heat away from the furnace to the chimney. The extent to which excess air may lower the temperature of combustion is evident from Table 7.

TABLE 7.—Effect of Excess Air on Temperature

| Combustible substance | Air required per pound of com- bustible pounds | Temperature of combustion ° C. | | | |
|-----------------------|--|--|--|--|--|
| | | With theo- retical supply of air ° C. | With 1½ times theo- retical supply ° C. | Two times theo- retical supply ° C. | Three times theo- retical supply ° C. |
| Hydrogen..... | 36.00 | 3170 | 2100 | 1570 | 1065 |
| Fuel oil..... | 15.43 | 2780 | 1930 | 1480 | 1010 |
| Anthracite coal. | 12.13 | 2530 | 1770 | 1335 | 900 |
| Bituminous coal. | 11.73 | 2830 | 1940 | 1470 | 985 |
| Wood (air dried) | 4.80 | 2090 | 1425 | 1150 | 811 |

In perfect combustion without excess air the resulting gases are carbon dioxide, steam and nitrogen. By making an analysis of the flue gases, the completeness of combustion may be readily ascertained by comparing the amounts of carbon dioxide and carbon monoxide. Since the volume of carbon dioxide produced in the complete burning of carbon is the same as the volume of oxygen consumed, the percentage of nitrogen in the flue gases would be same as in air when only carbon is burned and the combustion is complete. This relationship is however influenced by the presence of other elements in the fuel.

In practice complete combustion is obtained only when much more than the theoretical amount of air is supplied. Formulas are useful in calculating the quantity of air required per pound of fuel. The one chiefly used is given by Kent ¹ as follows:

$$\text{Pounds of air per pound of fuel} = 3.032 \left(\frac{N}{\text{CO}_2 + \text{CO}} \right) C$$

Where N, CO₂ and CO represent the percentages by volume of these constituents in the flue gases and C the percentage by weight of carbon in the fuel.

The quantity of air required for complete combustion may also be calculated from an ultimate analysis of the fuel by the formula:

$W = 11.59 C + 34.78 \left(H - \frac{O}{8} \right) - 4.35 S$, where W equals the pounds of air required per pound of fuel and C, H, O, and S represent the percentage of the elements respectively in each pound of fuel.

Then $V = vW$ where v = cubic feet of air per pound at the given temperature.

¹ Steam Boiler Economy, p. 32. See also *Science Abstracts*, Sec. B, 8, 109 (1905) for a check formula reading: Pounds of air per pound of fuel =

$$11.52 C \left(\frac{\text{CO}_2 + \frac{1}{2} \text{CO} + O}{\text{CO}_2 + \text{CO}} \right) + 34.56 \left(H - \frac{O}{8} \right).$$

Heat losses are due to a number of causes. Kershaw¹ estimates that the heat units per pound of fuel used, for example, in steam generation are distributed as follows:

| | <i>B. t. u.</i> |
|---|-----------------|
| Loss by radiation (10%). | 1350 |
| Losses in chimney gases (17.6%). | 2380 |
| Losses in ashes and cinders (5%). | 675 |
| Heat into steam (77.4%). | 9095 |
| | <hr/> |
| Total. | 13500 |

Frequently it is possible to utilize the waste heat in chimney gases in industrial operations, for which reason it is desirable to calculate the quantity of heat thus carried away. This calculation is based upon the rise of temperature (i. e., the difference in temperature of the flue gases and of the atmosphere), the weight of the gases, and their specific heats. The latter does not vary greatly in the case of the gases which constitute the bulk of the flue gas, as may be noted in the following table.²

TABLE 8.—Specific Heats of Flue Gas Constituents

| | |
|--------------------------|-------|
| Carbon dioxide | 0.234 |
| Carbon monoxide. | 0.245 |
| Oxygen. | 0.217 |
| Nitrogen. | 0.244 |
| Steam. | 0.480 |

For a rough approximation yet sufficiently accurate for most practical purposes, it is customary to take the weight of the products of combustion and multiply it by $.24 \times$ the elevation of temperature of escaping gases. Hence, heat = $Wc \times .24 \times (T-t)$ where T = temperature of the flue gases, and t = temperature of the atmosphere. To find Wc another approximation is made, viz.: $Wc = (Wf-a) + (AF)$

¹ *Power*, 26, 141 (1906).

² Fisher: *Handbuch der Technologie*, p. 75.

in which W_c is the weight of the products of combustion, W_f the weight of the fuel, a , the weight of the ash it contains, A , the weight of the air required, and F , the factor for the excess air admitted, or from analysis of flue gas

$$W_c = 3.032 \left(\frac{N}{CO_2 + CO} \right) \times C + (1-a).$$

The third impairment of the efficiency of combustion is due to an *insufficient air supply*, resulting either in carbon monoxide or finely divided particles of carbon or smoke in the flue gases.

The heat loss due to the formation of carbon monoxide is 10,150 B. t. u. per pound of carbon. When carbon is oxidized to carbon monoxide in an atmosphere deficient in oxygen, its heat value in B. t. u. per pound of carbon is 4450, while that of carbon oxidized to carbon dioxide is 14,600. When the latter is reduced to the monoxide, the heat absorbed by the process is 10,150 B. t. u. per pound of carbon. Hence in whatever manner the carbon monoxide found in the flue gases has been formed it impairs the efficiency of combustion to the extent of 70 per cent of the fuel value of the carbon contained in the carbon monoxide. Carbon monoxide is a colorless gas and although a deadly poison, its emanation from the stack is usually regarded merely as an evidence of lack of economy in combustion.

Prevention of Smoke.—In the case of the particles of carbon carried mechanically, however, the chimney gases are popularly recognized as being very objectionable to the community and constitute frequent causes of legal enactments. When smoke is produced in combustion there are two causes: (1) Insufficient oxygen to burn the gases; and (2) chilling of gases either by admission of cold air or by bringing them in contact with cold surfaces. Smokeless combustion¹ requires (1) adequate supply of preheated air,

¹ Sims: Smokeless Combustion of Bituminous Coal in Pittsburg District. *J. Eng. Soc. Western Pa.*, Nov. (1912).

(2) a large brick lined combustion chamber, and (3) an apparatus to mix gases given off with heated air. For the latter purpose use is made of jets of superheated steam under pressure. The use of mechanical stokers and powdered fuel is also instrumental in the elimination of smoke in combustion.

Spontaneous Combustion.—Since damaging fires have arisen from sources of spontaneous combustion, its prevention in the case of storage of fuel is very essential. Spontaneous combustion is generally ascribed to a process of slow combustion or oxidation of the fuel, which being a poor conductor of heat undergoes sufficient rise of temperature to cause ignition. According to Prof. Lewes ¹ this increase may be caused by (1) physical action, as in the absorption of a large volume of gas and its compression in the pores of the substances: (2) by rise in atmospheric temperature, as in the case of a vessel sailing through the tropics: (5) by direct chemical action (oxidation) at ordinary temperature and (4) by the action of ferments on organic matter. In the case of coal the absorption and subsequent compression of oxygen in the pores of the coal generates heat. If this heat cannot be radiated as fast as it is produced, the rate of oxidation increases with rise of temperature and the activity of the compressed oxygen increases until finally the kindling point of the hydrocarbons in the coal is reached and a flame is produced.

Destructive Distillation

The process of destructive distillation, which frequently accompanies combustion is also instrumental in producing certain transformations of fuels of great economic importance. In its widest sense destructive distillation refers to the decomposition of substances (usually of an organic origin) by heat without access of air. Since the final residue of the

¹ *Eng. Mining J.*, 82, 65 (1906).

substance thus decomposed consists mostly of carbon, the process is often designated as "carbonization." From a technical standpoint the chief interest lies in the products obtained by the action of heat on certain fuels. Such products may either be burned directly in combustion or they may be collected and converted into various articles of commerce which are commonly designated as "by-products." Chief in industrial importance are the products obtained from the destructive distillation of wood and coal.

WOOD DISTILLATION

The composition of wood varies with the kind of wood, the time of cutting and extent to which it has been dried or "seasoned." As explained in a subsequent chapter wood consists chiefly of the chemical compounds, cellulose ($C_6H_{10}O_5$)_n and lignin or ligno cellulose, together with "sap" and a very small amount of inorganic or mineral salts. The coniferous woods, such as pine and fir, contain also considerable quantities of volatile oils and resinous bodies. Obviously the nature of the products yielded when resinous wood is distilled will differ from those obtained in the distillation of ordinary "hard" wood such as oak, ash or maple.

CHARCOAL BURNING

The primitive method of manufacturing charcoal which was practiced by the ancients,¹ was to pile the wood in mounds or heaps, cover with earth or with a mixture of fine charcoal dust and earthy materials, and then kindle within the mound to start a partial combustion. Openings at the base provide for the admission and escape respectively of air and the gases of combustion. The heat of combustion is next utilized for decomposing the unconsumed wood, the

¹ Theophr. Erosius, who lived 300 years B. C. described such a method.

apertures having been closed in part. In this manner the wood keeps on "charring" or "distilling" until finally it is converted into charcoal. The gases resulting from combustion and decomposition of the wood are dissipated into the atmosphere.

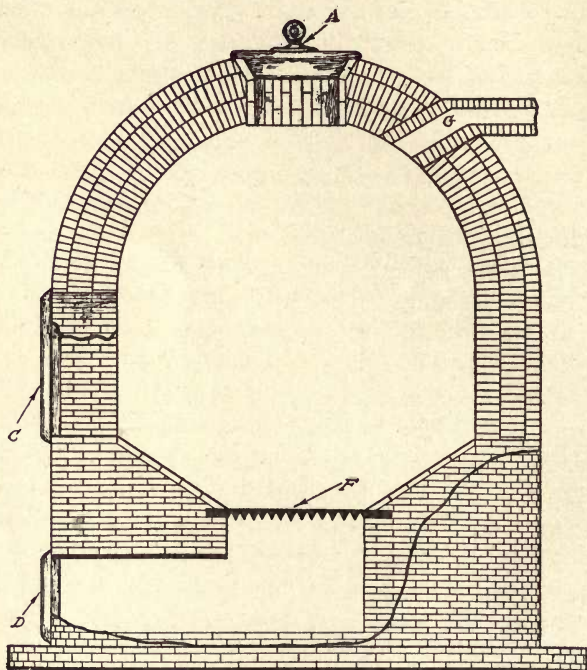

FIG. 30. Swedish Charcoal Oven.

Modifications of the primitive charcoal mound have been used in the form of the so-called Swedish oven (Fig. 30), which is constructed of brick having a suitable opening (*A*) for the charging of the oven with wood and for the removal of the charcoal (*C*). The bottom of the oven contains a grate (*F*) through which the air necessary for partial combustion is admitted. The quantity of air admitted is controlled by

means of doors (*D*) in the flues leading to the grate. After combustion has proceeded until the walls of the oven have attained a heat sufficient to complete the carbonization, the doors are completely closed and sealed with earth thrown against them or plastered over with clay. Thick, smoky vapors next appear from the orifice (*G*) at the top. These are led through a pipe to condensers and in part become liquids which constitute the "by-products."

Charcoal Retorts.—The modern charcoal retort is usually constructed of heavy iron plate in the form of a horizontal cylinder or rectangular shell set in brickwork. Firing boxes or furnaces are provided which produce the heat from the combustion of fuel and distribute it around the shell of the retort. The latter may vary in size but usually hold about 10 cords of wood, which is placed upon small iron cars on tracks within. No air is admitted during the heating of the retorts by the furnace gases and, as the temperature increases a true destructive distillation of the wood takes place. The gaseous products are conducted through outlets to the condensers and yield liquid products together with non-condensable gases which are for the most part combustible and are led back into the fireboxes and burned as fuel. After the wood has been wholly carbonized, the retort must be allowed to cool before it can be opened to remove the charcoal, or else an iron shell or cooler is provided into which the cars may be quickly run. After sealing the shell or cooler air tight so that no combustion can occur, the heat retained in the charcoal may be radiated through the iron shell. When this method of cooling is employed the retort may be again recharged while hot and the distillation of a new charge commenced.

The changes which wood undergoes when heated have been made the subject of an investigation by Violette¹ and

¹ *Ann. Chim. Phys.* (3), 32, 304; also Harper: Utilization of Waste Wood, p. 133.

Mills,¹ who show that the original cellulose molecule suffers a gradual resolution into simpler substances, the final residue being carbon or charcoal. The latter, however, always contains some volatile matter.

By-Products.—From a technical standpoint the interest lies as much in the products evolved as in the nature of the residues. When heat is applied to wood, the first product given off is moisture or steam. As decomposition continues other products such as organic acids, volatile oils, furfural, etc., are contained in the aqueous distillate which flows from the condensers. As disintegration continues less water relatively is given off and the heat supplied causes rapid decomposition of the wood. In the main from 160 to 275° C. an aqueous distillate known as pyroligneous acid is given off; from 275° to 350° C. gaseous products are liberated, while from 350° to 450° C. liquid and solid hydrocarbons known as wood tar are produced. The quantitative resolution of hard wood in approximate figures is as follows:

| | | |
|--------------------|---------------------|----------------------|
| <i>Solid (30%)</i> | <i>Liquid (50%)</i> | <i>Gaseous (20%)</i> |
| charcoal | water | carbon monoxide |
| | acetic acid (2%) | |
| | methyl alcohol (7%) | carbon dioxide |
| | acetone | |
| | furfural | |
| | tar (12%) | |

Both charcoal and carbon monoxide constitute a source of fuel which will be discussed later (Chap. V), but the separation of the constituents of the distillate involves a process of refining which requires some explanation. The following is a graphic presentation of the steps which take place in the distillation of hard woods such as oak or maple:

¹ *J. Soc. Chem. Ind.*, 4, 325 (1885).

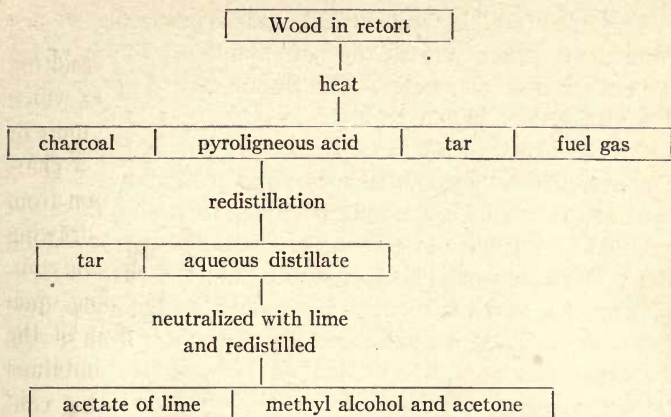

Crude pyroligneous acid is a dark red or brown liquid with a characteristic odor of burnt wood. The dark color is due to dissolved tar-like substances which may be partly removed by redistillation. When redistilled the pyroligneous acid has a pale straw color. It is next neutralized with lime, after which it is again heated in a still provided with a column head (q. v.) and cooler. By thus fractionally distilling, a mixture of methyl alcohol and acetone is obtained which may be further rectified into pure methyl alcohol, CH_4O , and acetone, $\text{C}_3\text{H}_6\text{O}$. The residue in the still contains acetate of lime, $\text{Ca}(\text{C}_2\text{H}_3\text{O}_2)_2$. It is usually evaporated to dryness in steam jacketed kettles or vacuum evaporators, dried, moderately heated to volatilize the tarry matter which separates from the pyroligneous acid upon neutralization with lime, and then becomes the commercial brown or gray (absence of tarry matter) acetate of lime. Acetate of lime in turn is the basis of the acetic acid industry, and is almost completely utilized in the manufacture of acetic acid by treatment with sulphuric acid in cast iron stills.¹

¹ For a complete description of the apparatus and process employed the student is referred to Klar: *Technologie der Holzverkohlung*, p. 246.

The term "tar" is applied to all of those products resulting from the destructive distillation of organic substances which are not miscible with water. These products are oily, more or less viscid, dark brown to black in color, and have a characteristic odor. In the case of wood tar its separation from the pyroligneous acid is usually accomplished by drawing it off at the bottom of the tank after it has settled. The composition of wood tar is extremely variable, depending upon the temperature employed in distillation, the shape of the retorts, the kind of wood, etc. A sample of tar obtained from the distillation of fir wood showed the following constants:

| | |
|----------------------------------|---------|
| Specific gravity at 18° C. | 1.068 |
| Flash point (open cup). | 105° C. |
| Fire point (open cup). | 131° C. |
| Free carbon. | 1.18% |
| Fixed carbon ¹ | 3.16% |
| Fractional distillation | |
| Below 110° C. | 4.00% |
| Between 110°-170° | 8.00 |
| Between 170°-270° | 61.00 |
| Residue (solid). | 22.00 |

The chemical composition of wood tar is quite complex, but it is essentially a mixture of phenol acids and their derivatives together with some higher hydrocarbons of both the fatty and aromatic series.

From a practical standpoint, wood tar has not found as extensive application as coal tar. In many distillation works tar is burned underneath the retorts as a fuel in much the same way as fuel oil. It is used to some extent in ship caulking and is applied to hemp ropes. It is now being refined in a number of plants into pharmaceutical preparations and also serves as a paint material. In the latter case it is necessary

¹ The term "fixed carbon" is used in the same sense here as in coal analysis. For explanation see the next chapter.

to separate the tar into its light oils which are used in the manufacture of shingle stains, while the heavy residue or "pitch" constitutes the base of paints used in the damp proofing of brick and concrete walls and for application to metallic surfaces.

When resinous woods are destructively distilled, volatile oils are carried over along with the steam and collect on the surface of the distillate or form a homogeneous solution with the tar. Special methods of distillation and refining are therefore employed. In some cases the wood is steamed for a number of hours prior to destructive distillation, by which process much of the volatile oil is carried over, forming, after condensation, a layer upon the water in the receiving tank. In other cases a solvent is passed over the wood to take up the volatile oils and resins which may be recovered by subsequent distillation with steam. When destructive distillation alone is employed, the volatile oils are recovered by subjecting the distillate to a second distillation with steam which yields a crude light oil from which wood turpentine is obtained by further refining.

Wood distillation has developed in the United States until at the present time about 120 plants are engaged in this work, the annual value of the products being quoted at approximately ten million dollars.¹ This does not include, however, turpentine and rosin among the products. The latter constitute a large industry in themselves, the output of some 1500 plants being estimated at more than twenty-five million dollars annually (*loc. cit.*).

DISTILLATION OF COAL

When coal is destructively distilled, gases, liquids and solids are produced, but in most respects the products thus

¹ Statistical Abstract of the United States (1911). Published by Bureau of Statistics.

obtained from coal differ markedly from the corresponding distillation products from wood. It was noted that the aqueous distillate in the case of wood was acid. In coal distillation, however, it is strongly alkaline. Differences in composition also characterize the tars obtained from wood and coal, coal tar consisting almost entirely of aromatic hydro-

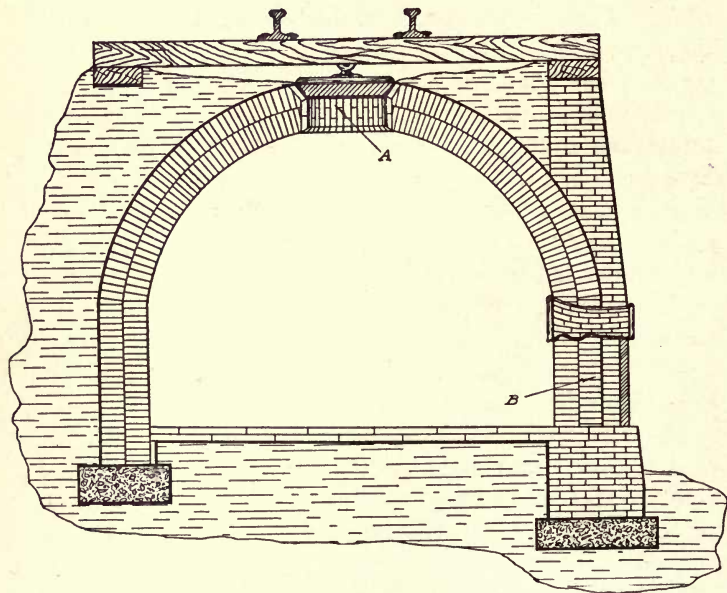

FIG. 31. Beehive Coke Oven.

carbons with a relatively small percentage of "tar acids" or phenols.

The composition of coal and its relation to wood will be discussed in a subsequent chapter. From the present standpoint we may regard it as composed of carbon, hydrogen, oxygen, nitrogen and other minor constituents, including some mineral matter. When destructively distilled it yields coke, a combustible gas, an aqueous distillate, and tar, com-

monly known as coal tar. The coke and gaseous products will be discussed in Chapters V and VI; our attention will now be directed to the refining of the "by-products," especially those of industrial importance.

The destructive distillation of coal for the manufacture of coke is carried on on a large scale because of the great demand for coke as a smokeless fuel able to support considerable weight. There are two general methods: (1) the "beehive" oven in which coke only is produced, and (2) retorts or "by-product ovens" in which coke, gas, ammonia and coal tar are the chief products.

Beehive Oven.—The "beehive" oven (Fig. 31) is quite extensively used in the United States, about 100,000 ovens being operated at the present time. The old form of oven was a circular brick chamber about twelve feet in diameter and three feet high to the springing of the dome which covers it and gives it the appearance of a beehive. It contains an opening (*A*) at the top for charging the coal which is fed into it from cars running on a track on top of a row of ovens. At the base, openings are provided for the admission of air which is so regulated that the products of distillation are burned but not the coke itself. When distillation is complete the coke is raked out through an opening (*B*) at the base into cars, quenched with water, and the oven recharged.

By-Product Oven.—The by-product coke oven is a narrow retort of firebrick construction (Fig. 32), about 30 to 33 feet long, 6 to 7 feet high, and from 17 to 22 inches in average width. Fifty of these retorts are placed side by side and constitute a battery.

A number of types of by-product ovens are in use of which the Semet Solvay and Otto Hoffman are perhaps the most important. These two types are identical in principle, the main difference being in the arrangement of the flues for the combustion of the gases used in

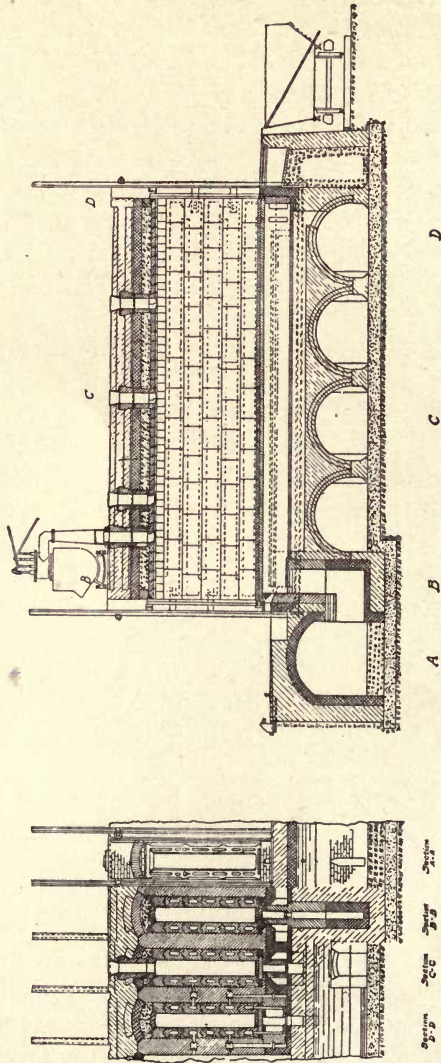

FIG. 32. Sections through a Semet Solvay Coke Retort.

heating them. The walls are provided with internal flues heated by gas and are arranged vertically in the Otto Hoffman and horizontally in the Semet Solvay. The ovens are charged with coal from specially constructed cars on top of the retort. After charging, the ends of the retorts are tightly luted with clay and the heating is begun. The heat is obtained from the combustion of "coke oven gas," a product of distillation from the previous charge. This gas is delivered to the retort by mains running along each side of the battery, a burner being at either end of the oven. The air for combustion is drawn by a fan from openings at the end of the battery and is passed through heated checkerwork passages which constitute regenerative chambers underneath the battery. In this way the air becomes heated to about 980° C. and is next distributed to the combustion chamber where it meets the gas from the burner. The burning gases pass through the flues in the wall, then through the checkerwork underneath, where a portion of their heat is absorbed, and at a temperature of 390° C. are passed into various forms of apparatus for steam generation, evaporation or distillation before finally passing to the stack. Each battery of ovens is equipped with two regenerators, one heating the air while the other is being heated by the gases from the flues. In practice the process is reversed every thirty minutes. From 16 to 26 hours are required to distil the coal.

The products of distillation of coal in these air-tight ovens are led away through uptake pipes to the gas collecting main. In case the gas is to be used for fuel and illuminating purposes two hydraulic mains and an additional system of condensation are required, or else a number of units working in parallel with by-passes may be used to separate the rich gases from fuel gases.

The gas from the hydraulic main first passes through air coolers which lead the gas to and fro through passages of steel plate construction, exposing a large surface for atmospheric

cooling and often provided with an external sprinkling system for use in hot weather.

The temperature of the gas is next reduced by the use of tubular water coolers in which the gas space is divided by numerous successive baffles, causing the gas to follow a tortuous course while being cooled by water flowing in a parallel, but opposite direction.

In order to maintain a constant flow of gas and render its control easier, use is made of steam or electrically driven exhausters which force the gas from the coolers into the tar scrubbers. In these the gas is led through a series of thin, perforated steel plates so arranged that, after the gas has passed through an opening, it is thrown with high velocity against an unperforated plate, causing it to lose the tar, which drops down, and is collected in tar cisterns.

From the tar scrubbers the gas goes to the ammonia scrubbers, in which it passes upwards through a latticework of wooden slats; while the scrubbing water passes downward, absorbing the ammonia. Fresh water is used in the last one, and the weak liquor resulting is successively used in the scrubbers preceding this, until strong enough for distillation. The washings from the scrubbers contain water, ammonia and tar. The latter settles on standing and is collected in tar cisterns, while the former constitutes the crude ammoniacal liquor from which ammonia is obtained.

Ammonia.—The nitrogen content of the coals used in coke manufacture usually varies from 1.2 to 1.46 per cent. According to Pennock¹ about one-fifth of this nitrogen is recovered as ammonia, about three-fifths remains in the coke and the rest is distributed among the distillation products.

To obtain the ammonia in marketable form, it is necessary to distil it off from the ammoniacal liquor and to reabsorb it in sulphuric acid. The ammoniacal liquor contains from .5 to 2 per cent of ammonia; partly in the "free" form and

¹ Pennock: *J. Ind. Eng. Chem.*, 4, 174 (1912).

partly "fixed," i. e., combined in a variety of compounds. The free or volatile ammonia is driven off by steam as ammonia gas, and the water containing the fixed ammonia passes into the liming chamber where it is liberated by the action of lime on the ammonia compounds. This liberated ammonia is converted into vapor by the action of the steam, as before, and passed into sulphuric acid where it is converted into ammonium sulphate. Or by leading the ammonia vapors through condensers and saturators, an ammonia liquor containing 15 to 20 per cent of ammonia may be obtained. In the latter form it is used in the manufacture of alkali, soap and chemicals of various forms. Ammonium sulphate is chiefly used as a fertilizer. It is sold in the form of gray crystals containing about 20 per cent nitrogen and the yield is about 27 pounds from each ton of coal coked.

Coal Tar.—The tar from the cisterns is usually sold to refiners, who obtain a variety of products from it. The amount obtained per ton of coal varies from 30 pounds to 110 pounds. The composition ¹ of coal tar is extremely complex and variable, depending on the amount of heat applied in distillation, the quality of the coal, shape of the retort, and the pressure within the retort. When low heat is applied the tar contains large quantities of compounds belonging to the paraffin series, while with high temperature the aromatic series is present almost entirely.

In distilling coal tar according to the German method of fractionating, the following products are obtained:

| | |
|------------------------------|---------------|
| First light runnings. | below 110° C. |
| Light oils. | 110°-210° C. |
| Carbolic oils. | 210°-240° C. |
| Heavy or creosote oils. | 240°-270° C. |
| Anthracene. | 270°-400° C. |
| Residue. | above 400° C. |

¹ For a full discussion of the constituents of coal tar the student is referred to Lunge: *Coal Tar and Ammonia*, Part 1, pp. 160-241.

The first runnings and light oils contain benzene, toluene, and the xylenes; the carbolic oils contain phenol, and cresols, and some naphthalene; the creosote oils contain some phenol, naphthalene, anthracene, and many other hydrocarbons; and the anthracene oils contain anthracene, acridene, and other compounds. The residue in the still is either soft or hard pitch, depending on distillation. When the anthracene oil is completely distilled off, the residue is hard pitch used as a binder for briquettes and in the manufacture of electric light carbons. Soft pitch contains a larger number of the high boiling tar constituents, and is used for roofing and building papers.

Coal tar is the source of the so-called "creosote" used in wood preservation. This term is somewhat indiscriminately applied, and requires definition. Creosote in its narrowest sense refers to a mixture of antiseptic phenols and phenoloid bodies obtained from wood tar. In commercial practice the term, however, is applied to the "distillate heavier than water obtained by the distillation of tar or a tar-like body."¹ The commercial creosote, therefore, consists of that portion of crude coal tar from which the light oils and the pitch have been removed. Essentially it consists of (1) a small percentage of tar acids or "light oils" which distil below 205° C.; (2) naphthalenes which distil between 205° and 255° C.; and (3) constituents of an anthracene nature distilling above 255° C., which are generally referred to collectively as anthracenes. Its production from coal tar is indicated in the following diagram:

¹ Forest Service, Circular 206 (1912).

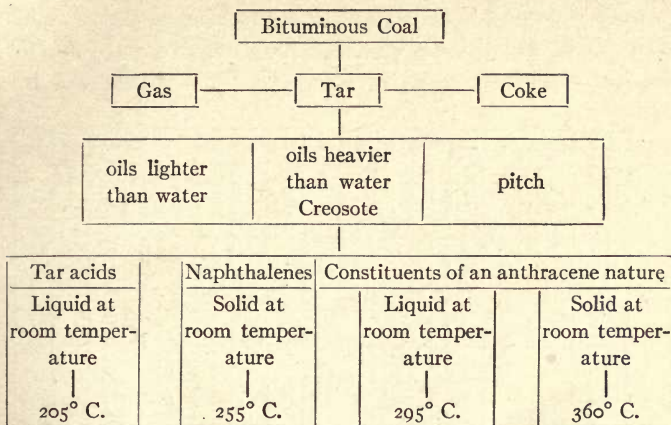

Benzene.—About 57 per cent of the light oil fraction (i. e., up to 210° C.) of coal tar consists of benzene. The illuminating power of coke oven gas is also due to the presence of benzene. It may be removed from gas to be used for fuel purposes without impairing its heating power by passing the gas through washers in which tar or paraffin oils are used as the scrubbing liquor. This absorbs the benzene, which may be obtained from the mixture by distillation. The crude benzene is used for enriching illuminating gas while the refined benzene is the basis of the aniline dye industry. It is also used in the manufacture of drugs, paints, perfumes, explosives and other products.

Cyanides may be recovered chiefly in the form of potassium ferro-cyanide the yield of which is about 1.25 pounds per ton of coal.

The Relative Importance of By-product Ovens may be readily noted by the rate of increase in the number of new ovens which are of the by-product type (Fig. 33). At the end of the year 1910, of a total of 2567 ovens under construction 1200, or 46.75 per cent were by-product ovens. Inasmuch as a by-product oven produces four times as much coke as a

beehive it follows that the additional producing capacity of 1910 was more largely by-product than beehive and leads to the belief that the coke production of the future will be

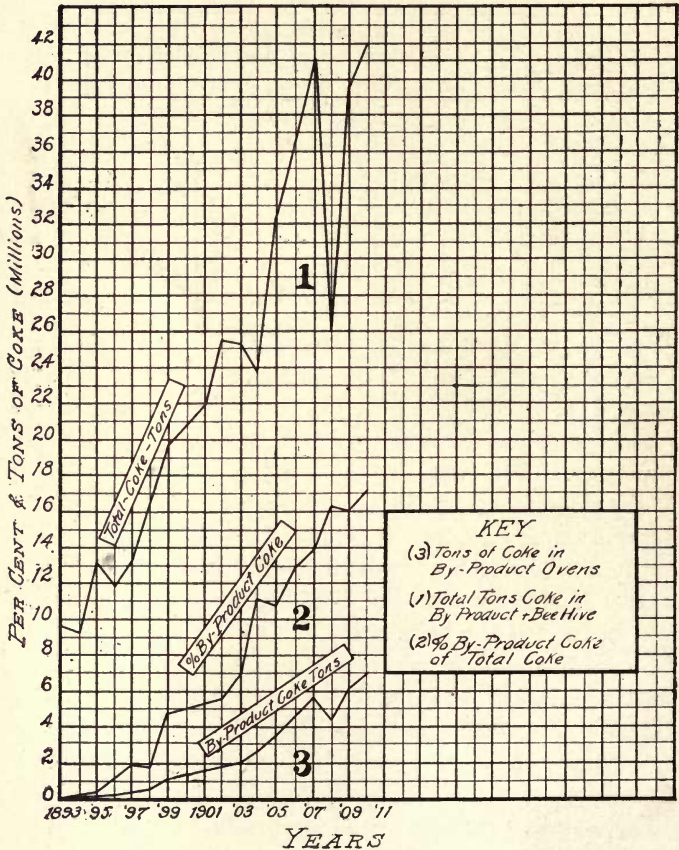

FIG. 33. Illustrating the Relative Increase of By-product Coke Ovens.

largely carried on in by-product ovens. In addition to the increased yield of coke the saving of the by-products is very material as is evident from the following statement of quan-

tity of products obtained from the by-product ovens in 1909 in making 6,254,644 short tons of coke comprising 16 per cent of the total coke production.

| | <i>Quantity</i> | <i>Value</i> |
|--------------------------------------|-----------------|--------------|
| Surplus gas (M cubic feet) | 15,791,220 | \$2,609,211 |
| Tar (gallons) | 60,126,006 | 1,408,611 |
| Ammonia (pounds of sulphate) | 123,111,197 | 3,227,316 |
| Andyhrous ammonia (pounds) | 4,871,014 | 448,455 |
| All other products | | 380,355 |
| | <hr/> | <hr/> |
| Total value of by-products. | | \$8,073,948 |

This statement shows therefore that approximately forty million dollars worth of products annually are lost in the manufacture of the coke produced by beehive ovens. Parsons¹ has summarized the losses sustained by the use of beehive ovens by stating that in 1911 the bituminous coal converted into coke contained \$22,000,000 worth of nitrogen, easily recoverable as ammonium sulphate, of which only \$3,800,000 was actually recovered. He also calls attention to a loss of over \$20,000,000 worth of gas and coal tar which was wasted through the use of beehive ovens. Pennock (loc. cit.) has further cited that, if the gas wasted in the beehive ovens were utilized for fuel purposes, it would be equivalent to a saving of 9,713,000 tons of coal annually.

REFERENCES

I

- ANDERSON: The Chemistry of Coke.
 BERTHELOT: Thermochemie.
 BRISLEE: Introduction to Study of Fuels.
 BURGESS AND LECHATLIER: The Measurement of High Temperatures.
 BYRON AND CHRISTOPHER: Modern Coking Practice.
 CHRISTIE: Furnace Draft, its Production by Mechanical Methods.

¹ *J. Ind. Eng. Chem.*, 4, 177 (1912).

- DUMESNY AND NOYES: Wood Products, Distillates and Extracts.
 FULTON: Coke.
 HARPER: Utilization of Waste Wood by Distillation.
 HUBBARD: Coke Oven Tars for the United States, Circular 97, Office of Public Roads.
 : Utilization of Wood Waste.
 JÜPTNER: Heat Energy and Fuels.
 KLAR: Technologie der Holzverkohlung.
 LUNGE: Coal Tar and Ammonia.
 NICHOLSON: Smoke Abatement.
 POOLE: Calorific Power of Fuels.
 RICHARDS: Metallurgical Calculations.
 SEXTON: Fuel and Refractory Materials.
 STERLING: Steam.
 THOMSON: Thermochemistry (translation by Burke).
 U. S. BUREAU OF MINES: Bulls. 39 and 40.
 U. S. GEOLOGICAL SURVEY: Bull. 373, The Smokeless Combustion of Coal in Boiler Furnaces.
 WIGGINS, SMITH AND WALKER: The Products of the Distillation of Pinewood.

II

- CHRISTIE: Economy in Fuel Combustion. *Eng. Mag.*, 21, 81 (1901).
 OLSEN: Chemistry of Combustion. *Engineer*, 40, 251 (1901).
 PALMER: Steam Jets for Preventing Smoke. *Am. Mach.*, 26, 936 (1903).
 DOANE: The Spontaneous Ignition of Coal. *Eng. News*, 52, 141 (1904).
 BENJAMIN: Smoke and its Abatement. *Trans. Am. Soc. Mech. Eng.*, 26, 713 (1905).
 HENDERSON: Heat of Combustion of Atoms and Molecules. *J. Phys. Chem.*, 9, 40 (1905).
 KERSHAW: Industrial Smoke and its Prevention. *Cassier*, 29, 109 (1905).
 MAJOR: Combustion. *Power*, 26, 66 (1905).
 THOMPSON: Heats of Combustion. *J. Chem. Soc.*, 88, 571 (1905).
 ATWATER: Smokeless Fuel for Cities. *Cassier*, 30, 313 (1905).
 JUDD: Beehive Coke Oven Practice. *Iron Age*, 79, 190 (1906).
 MOSS: The Chemistry of Combustion. *Power*, 26, 619 (1906).
 BENJAMIN: Smoke Prevention in the Power House. *Cassier*, 31, 339 (1907).
 LUCKE: The Influence of Central Station Loads on Smoke Production. *Power*, 27, 150 (1907).
 BRECKENRIDGE: Smokeless Combustion of Coal. *Eng. Mag.*, 34, 1055 (1908)

- LEWES: Thermal Value of Fuels. *Sci. Am.*, **66**, 294 (1908).
- EMERSON: A New Bomb Calorimeter. *J. Ind. Eng. Chem.*, **1**, 17 (1909).
- FISCHER AND WREDE: Use of Platinum Resistance Thermometer in Determining Heat of Combustion. *Z. Physik. Chem.*, **69**, 218 (1909).
- HAANEL: Modern Methods of Manufacturing Charcoal. *Iron Coal Trades Rev.*, Oct. 27 (1909).
- STEELY: Carbon Dioxide and Chimney Losses. *Sci. Am. S.*, **68**, 66 (1909).
- TEEPLE: Pine Products from Pine Woods. *J. Ind. Eng. Chem.*, **1**, 597 (1909).
- BASKERVILLE: The Smoke Problem and the Community. *J. Ind. Eng. Chem.*, **2**, 355 (1910).
- BEMENT: Influence of Oxygen in the Value of Coal. *Science*, **30**, 922 (1910).
- FOWLER: Scientific Control of Kiln and Oven Gases (Description of Sarco Carbon Dioxide Recorder). *Trans. Eng. Ceramic Soc.*, **9**, 25 (1910).
- HIGMAN: Electrical Distillation of Turpentine. *Eng. Mag.*, **39**, 108 (1910).
- HUNTLEY: Accuracy Obtainable in Fuel Calorimetry. *J. Soc. Chem. Ind.*, **29**, 917 (1910).
- RISPLER: Coal Tar Industry (Naphthalene Manufacture). *Chem. Ztg.*, **34**, 730 (1910); *Chem. Abs.*, **5**, 778 (1911).
- WHITE: Temperature Measurement in Calorimetry Work. *Physic. Rev.*, **31**, 562 (1910).
- CARO: Recovery of Ammonia from Peat. *Chem. Ztg.*, **35**, 505 (1911).
- CHURCH: Methods for Testing Coal Tar, Oils and Pitches. *J. Ind. Eng. Chem.*, **3**, 227 (1911).
- FRANKFORTER: Waste Wood and its Utilization. *J. Ind. Eng. Chem.*, **3**, 4 (1911).
- GURNEY: Heat Transmission. *J. Ind. Eng. Chem.*, **3**, 455 (1911).
- HEMPEL AND LIERG: The Chemistry of the Coking Process. *Zeit. angew. Chem.*, **24**, 2044 (1911).
- JONES: Manufacture of Ammonia in By-Product Coke Ovens. *J. Ind. Eng. Chem.*, **3**, 589 (1911).
- KERSHAW: Dust, Soot and Smoke. *Cassier*, **39**, 251 (1911).
- LAWRENCE: Utilizing Wood Waste by Destructive Distillation. *J. Soc. Chem. Ind.*, **30**, 728 (1911).
- LEWES: Coal Carbonization. *Progressive Age*, **29**, 1029 (1911).
- RIDDELL: Gas and Smoke. *J. Gas Lighting*, **115**, 294 (1911).
- WALKER: Methods for the Utilization of Wood Waste. *J. Soc. Chem. Ind.*, **30**, 934 (1911).

- WEISS: Commercial Benzol in United States. *J. Ind. Eng. Chem.*, **3**, 10 (1911).
- WHITE: Recent Progress in Calorimetry. *Met. Chem. Eng.*, **9**, 202 (1911).
- WHITE AND BARKER: Coals Available for the Manufacture of Illuminating Gas. U. S. Bureau of Mines, Bull. 6 (1911).
- WHITTAKER: Tar and Tar Products. *Progressive Age*, **29**, 915 (1911).
- WILSON: Efficiency in Fuel Combustion. *Cassier*, **40**, 652 (1911).
- BENSON: The Fractional Distillation of Wood Tar by Electrical Heat. *Met. Chem. Eng.*, **10**, 544 (1912).
- HARTMAN: By-Product Coke Ovens. *Proc. Eng. Soc. of Western Penn.*, **28**, 311 (1912).
- HAWLEY AND PALMER: Relative Yields obtained by the Destructive Distillation of Different Forms and Species of Hard Woods. *Proc. 8th Intern. Congr. Appl. Chem.*, **6**, 138 (1912).
- PARKER: Manufacture of Coke in 1911. U. S. Geol. Survey (1912).
- PRITCHARD: Some Recent Developments in Wood Distillation. *J. Ind. Eng. Chem.*, **4**, 338 (1912).
- RANDALL: The Smoke Problem at Boiler Plants. U. S. Bureau of Mines, Bull. 39 (1912).
- RANDALL AND WEEKS: Smokeless Combustion of Coal in Boiler Furnaces. U. S. Bureau of Mines, Bull. 40 (1912).
- SHOOK: Calibration of Radiation Pyrometers. *Met. Chem. Eng.*, **10**, 416 (1912).
- BELDEN: Beehive Coke Oven Industry of the United States. *J. Ind. Eng. Chem.*, **5**, 71 (1913).
- CHRISTOPHER: Progress in By-Product Recovery at Coke Ovens. *Jour. Soc. Chem. Ind.*, **32**, 115 (1913).
- PARKER: Manufacture of Coke in 1912. U. S. Geol. Survey (1913).

CHAPTER V

SOLID FUELS

As ordinarily employed the term *fuel* includes all substances which can be burned by means of air in such manner as to produce sufficient heat for practical utilization for domestic or industrial purposes. Fuels are usually composed wholly or in part of carbon, or hydrogen, or both. In exceptional cases other materials are used. Examples are furnished in the use of sulphur in the production of heat in the sulphur refining processes in Sicily and in the manufacture of sulphuric acid and also of silicon and phosphorus in the refining of pig iron (q. v.). A case of special interest is the use of aluminum in the Goldschmidt thermit process, in which a mixture of fine aluminum and metallic oxides is caused to react and produce high temperatures.

The present discussion will be confined to carbonaceous fuels and for convenience the classification suggested by Juptner¹ will be followed:

| <i>Kind of fuel</i> | <i>(A) Natural</i> | <i>(B) Artificial</i> |
|---------------------|--------------------|--|
| I. Solid | Wood, peat, coal | Charcoal, coke, briquettes. |
| II. Liquid | Petroleum oil | Tar, gasoline, alcohol. |
| III. Gaseous | Natural gas | Illuminating, producer, water, blast furnace, and acetylene gas. |

NATURAL SOLID FUELS

The natural solid fuels numerated in Juptner's classification have a number of characteristics in common. They all

¹ Heat Energy and Fuels. English translation by Nagel, p. 141

contain ash (the substance remaining after combustion), hygroscopic water, generally called moisture, and a mixture of combustible compounds which consist of carbon, hydrogen, and oxygen, together with smaller quantities of sulphur and nitrogen. They are all derived from the woody materials of the stems and leaves of plants, and the changes may be followed through an unbroken series from vegetation through peat, lignite, bituminous coal, anthracite, and graphite. The mechanism of these changes may not be wholly clear, yet it is plain that they consist in the breaking down of the complex vegetable compounds with elimination of products of oxidation until at the end of the series we find practically nothing of the original material save carbon and ash. The general nature of the change is well illustrated by the content of carbon, oxygen and hydrogen shown in the following typical analyses:

TABLE 9.—Composition of Fuels and Fuel Sources

| <i>Substance</i> | <i>Carbon</i> | <i>Hydrogen</i> | <i>Oxygen</i> |
|--------------------------------|---------------|-----------------|---------------|
| Cellulose. | 44.44 | 6.18 | 49.38 |
| Ligno cellulose. | 47.06 | 5.89 | 47.06 |
| Wood fiber | 52.65 | 5.25 | 42.10 |
| Peat. | 59.57 | 5.96 | 34.47 |
| Lignite. | 66.04 | 5.27 | 28.69 |
| Brown coal. | 73.18 | 5.58 | 21.14 |
| Bituminous coal. | 75.06 | 5.84 | 19.10 |
| Semi-bituminous coal | 89.29 | 5.05 | 6.66 |
| Anthracite coal. | 91.58 | 3.96 | 4.46 |

WOOD

Wood as a fuel is not of great industrial importance although its domestic use is very extensive. Its adaptability

as a fuel is conditioned by the amount of water it holds, which in turn varies with the kind of wood, the time of year in which it is cut, and the mode of drying. The variation of water in freshly cut wood is from 26 per cent in willow to 50 per cent in poplar. The seasonal variation is as much as 10 per cent. When sawed or split and exposed to the air for about a year it becomes "seasoned" or "dried," and its water content is reduced to about 20 per cent. When kiln dried a still larger percentage of water is driven off, usually leaving about 4 to 6 per cent water. Its oxygen content being high (see Table 9), the combustible elements are already partially oxidized. The heating value is therefore low, that of air dried wood averaging about 5600 B. t. u., and that of kiln dried wood about 8000 B. t. u. per pound. Each pound of kiln dried wood requires for combustion about 6 pounds of air. One cord of seasoned wood (about 3200 pounds) is equivalent to nearly one ton of coal. The experiments of Weber and Gottlieb show that the heat per pound of soft wood is greater than that of hard wood.

The ultimate analysis of wood, absolutely dry, is given by them as follows:

| | <i>Carbon</i> | <i>Hydrogen</i> | <i>Nitrogen</i> | <i>Oxygen</i> | <i>Ash</i> | <i>B. t. u.</i> |
|-----------|---------------|-----------------|-----------------|---------------|---------------|------------------|
| | <i>p. ct.</i> | <i>p. ct.</i> | <i>p. ct.</i> | <i>p. ct.</i> | <i>p. ct.</i> | <i>per pound</i> |
| Oak . . | 50.16 | 6.02 | 0.09 | 43.36 | 0.37 | 8316 |
| Pine . . | 50.31 | 6.20 | 0.04 | 43.08 | 0.37 | 9153 |
| Fir . . . | 50.36 | 5.92 | 0.05 | 43.39 | 0.28 | 9063 |

Ultimate analyses of the dry matter of certain wood products examined by Sherman and Amend¹ showed the following results:

¹ *School of Mines Quarterly*, 33, 31 (1911).

| <i>Substance</i> | <i>Carbon</i> | <i>Hydrogen</i> | <i>Oxygen</i> | <i>Nitrogen</i> | <i>Sulphur</i> | <i>Ash</i> | <i>B. t. u. per pound</i> |
|-----------------------------------|---------------|-----------------|---------------|-----------------|----------------|---------------|---------------------------|
| | <i>p. ct.</i> | <i>p. ct.</i> | <i>p. ct.</i> | <i>p. ct.</i> | <i>p. ct.</i> | <i>p. ct.</i> | |
| Chestnut wood chips. | 50.28 | 5.58 | 43.21 | 0.10 | 0.03 | 0.80 | 8340 |
| Chestnut wood chips, leached. . . | 50.09 | 5.65 | 43.33 | 0.10 | 0.02 | 0.81 | 8390 |
| Hemlock tan. . . . | 53.74 | 5.66 | 39.05 | 0.24 | 0.04 | 1.27 | 9190 |
| Hemlock tan, leached. | 54.97 | 5.73 | 37.69 | 0.26 | 0.02 | 1.33 | 9390 |
| Oak tan, leached. | 49.51 | 5.53 | 39.24 | 0.40 | 0.05 | 5.27 | 8640 |

The relation between ultimate composition and heat of combustion of the *dry matter* of wood is approximately as follows:

$$\text{Heat of combustion in calories} = 8080 (\text{C} - \frac{3}{8}\text{O}) + 34,500 \text{H} + 2250 \text{S}.$$

Attempts to calculate the calorific power from the ultimate analysis of a wood according to Dulong's formula (see under Coal below) yield figures much below the true thermal values (Sherman and Amend; *loc. cit.*).

The ash of wood consists essentially of carbonates of potassium, calcium, magnesium, and sodium, with some phosphates, sulphates and silica. Wood ashes are of value as a fertilizer. They were also formerly leached with water and the soluble portion (lye) used in the manufacture of soft soap. The cheapening of the methods of manufacture of both soaps and alkalis has rendered this use of ashes unprofitable.

PEAT

Peat as a fuel has not attained any great prominence in the United States, but recent tests have shown that it can, in some localities, successfully compete with wood and coal.

It is formed by the decomposition of various mosses and sedges growing in swamps, eventually giving rise to peat bogs. Extensive deposits occur in Great Britain, and it is estimated that one seventh of the surface of Ireland is peat bog. Large and accessible deposits of peat occur in Florida, Massachusetts, Maine, Minnesota and Wisconsin, and in general throughout the central and northern states and the provinces of Canada.

The changes which have taken place in the transformation of vegetable matter into peat may be observed in the following analyses ¹ made from dried samples and calculated on an ash free basis:

| | <i>Sphagnum</i> moss | <i>Light peat</i> | <i>Black peat</i> | <i>Heavy</i> <i>brown peat</i> |
|------------------------|-------------------------|-------------------|-------------------|-----------------------------------|
| Carbon. p. ct. | 49.88 | 50.86 | 59.71 | 62.54 |
| Hydrogen. " | 6.54 | 5.80 | 5.27 | 6.81 |
| Oxygen. " | 42.42 | 42.57 | 32.67 | 29.24 |
| Nitrogen. " | 1.16 | .77 | 2.95 | 1.41 |

The nature of these changes is partly understood and is generally explained as consisting in a decay of ligneous fiber through a process of fermentation resulting in the formation of organic acids known as the humus acids.² These acids dissolve and are partly washed away, but the salts formed with lime and iron, being insoluble, probably remain behind, beds of the latter often appearing as bog ore. Bituminous and resinous matters are also found in some types of peat, especially in black or thoroughly decomposed peat.

From the standpoint of its analysis as a fuel, raw peat exhibits a wide variation, due to its moisture content, as may

¹ *J. prakt. Chem.*, 92, 65 (1864).

² U. S. Geological Survey: Bull. 330, p. 646.

be noted in the following analyses taken from Bulletin 16 of the United States Bureau of Mines:

| | <i>Moisture</i> | <i>Volatile Matter</i> | <i>Fixed Carbon</i> | <i>Ash</i> | <i>Sulphur</i> | <i>Calories</i> | <i>B. t. u.</i> |
|--------------|-----------------|------------------------|---------------------|------------|----------------|-----------------|-----------------|
| Florida peat | 82.12 | 11.75 | 5.72 | .41 | .05 | 1048 | 1886 |
| “ “ | 54.39 | 29.78 | 13.88 | 1.95 | .22 | 2469 | 4444 |
| Michigan “ | 11.93 | 53.52 | 28.38 | 6.17 | .20 | 4905 | 8829 |
| Maine “ | 82.84 | 10.83 | 5.49 | .84 | .03 | 927 | 1669 |

When air dried, the value of peat as a fuel, of course, becomes greater and approaches low grade coal, in heating power. What has been said under wood above regarding the relation between the ultimate composition of the dry matter and the calorific power applies also to peat.

A number of analyses taken from Bulletin 16 (*loc. cit.*) illustrate the nature of air dried peat from a fuel standpoint.

| | <i>Moisture</i> | <i>Ash</i> | <i>Sulphur</i> | <i>Calories</i> | <i>B. t. u.</i> |
|---------------------|-----------------|------------|----------------|-----------------|-----------------|
| Brown peat. | 6.34 | 7.93 | 0.69 | 5161 | 9290 |
| Black “ | 6.62 | 24.11 | 1.01 | 3992 | 7186 |
| Brown “ | 19.69 | 3.23 | .19 | 4273 | 7691 |

The method employed in preparing peat for use as a fuel is to convey it to a mill, disintegrate it, and mold it into brick. In the case of the Florida peat, these bricks at first carry about 85 per cent water, but, by drying in the sun, the moisture may be reduced to 15 per cent.

Tests of Florida peat for use as a producer gas fuel and also for steaming purposes were made at the coal testing plant at

St. Louis.¹ The following comparative statement illustrates its value as a fuel:

| Equivalent pounds of dry fuel used per electrical horse-power as developed at switchboard: | |
|--|------|
| Florida peat in producer gas plant. | 2.39 |
| North Dakota lignite in producer gas plant. | 2.29 |
| North Dakota lignite in producer gas plant. | 2.08 |
| Florida peat under a steam boiler. | 5.78 |
| North Dakota lignite under a steam boiler. | 5.41 |

The value of peat for fuel and other uses has been fully described in Bulletin 16 of the United States Bureau of Mines, by C. A. Adams. According to the conclusions of Mr. Adams, peat briquettes present many favorable qualities, such as freedom from smoke, small ash content, complete combustion, and prospective low price. It is believed also that peat will become important in the production of producer gas and for firing boilers in the form of peat powder.

COAL

Coal has been formed from the partial decay of prehistoric vegetation, its formation requiring an enormous lapse of time. The combustible matter of coal consists chiefly of carbon, hydrogen and oxygen with small amounts of nitrogen and sulphur. Some of the carbon may be present in a free state, some combined with hydrogen as hydrocarbons, some with hydrogen and oxygen as partially carbonized residues of the original woody tissue. Hard dry anthracites contain much free carbon, while soft "fat" bituminous coals have more of the hydrocarbons, and lignites show more of the relationship to woody tissues.

A brief outline of the proximate analysis of coal may make clearer the significance of the terms used in the following

¹ Mineral Resources of United States (1905), p. 1320.

discussion. A portion of the finely ground coal is dried at 104° – 107° C. for an hour to expel *moisture*. The loss of weight from the solid matter when heated for seven minutes at the full heat of a Bunsen burner in a covered platinum crucible is then determined; this is called *volatile matter*. *Ash* is determined by burning the residue from one of the above determinations (or another portion of the coal) until all combustible matter is oxidized. *Fixed carbon* is found by subtracting the sum of the percentages for moisture, volatile matter, and ash from 100.

The classification ¹ of coal is based on the relative amounts of fixed carbon and volatile matter. The limits given by Kent are as follows (based on the combustible dry matter of the coal):

| | <i>Fixed carbon per cent</i> | <i>Volatile matter per cent</i> |
|-----------------------------|----------------------------------|-------------------------------------|
| Anthracite. | 97 –92.5 | 3 – 7.5 |
| Semi-anthracite. | 92.5–87.5 | 7.5–12.5 |
| Semi-bituminous. | 87.5–75 | 12.5–25 |
| Eastern bituminous. | 75 –60 | 25 –40 |
| Western bituminous. | 65 –50 | 35 –50 |
| Lignites. | under 50 | over 50 |

Lignites, representing the intermediate product between peat and coal, have variable composition and appearance.

¹ Numerous systems of classification have been proposed but no uniform or commonly accepted classification is in use. For fuller discussion, the student is referred to the following papers:

Frazer: *Trans. Am. Inst. Min. Eng.*, 6, 430 (1878).

Parr: *J. Am. Chem. Soc.*, 28, 1425 (1906).

Campbell: *Trans. Am. Inst. Min. Eng.*, 36, 324 (1905); also U. S. Geol. Survey, Professional Paper, No. 48.

White: U. S. Geol. Survey, Bull. No. 382.

Hachita: *Chem. Abs.*, 1, 1465 (1907).

The western lignites are black, but most of the lignites are brownish, whence the name (brown coal) frequently used to designate them. When brown coal or peat is destructively distilled, the aqueous distillate gives an acid reaction, as in wood distillation. Hence they contain ligno cellulose, whence the name lignite. Lignites are therefore of more recent formation than other kinds of coal. They break easily in transportation, and when freshly mined contain as high as 50 per cent of moisture. The ash content of lignite usually runs from 5 per cent to 35 per cent. On account of the large amount of moisture and ash they have a low calorific value, about 8000 to 11,000 B. t. u.

Bituminous Coal is the chief coal of industry. It constitutes about two-thirds of the entire annual output of coal (including lignite) in the United States. Bituminous coals are classified as coking and non-coking, or free burning. The former are valuable for gas manufacture and are used in the production of coke, while the latter are largely used for steam production. The emission of yellow flame and smoke is characteristic of bituminous coal. When the volatile matter is very high (50 per cent or more) bituminous coals are described as "fat," a small content of volatile matter causing the coal to be called "lean."

"**Semi-Bituminous**" is a bituminous coal with low volatile matter. It has a texture approaching anthracite and burns with a short flame. The Pocahontas coal of West Virginia is a type of semi-bituminous coal.

Anthracite Coal represents the highest stage of the mineralization of coal. It contains little moisture and volatile matter, but runs high in carbon. It is hard, lustrous, and has a vitreous fracture. It is hard to ignite, but burns with an intense heat when supplied with 12 times its weight of air. Pennsylvania produces practically the entire supply of the United States.

The tables of analyses given below indicate the variations

in comparison and heating value between the different classes of coal.

TABLE 10.—Proximate Analyses of Coal ¹

| <i>Kinds of coal</i> | <i>Moisture</i> | <i>Volatile matter</i> | <i>Fixed carbon</i> | <i>Ash</i> | <i>Sulphur</i> |
|--|-----------------|------------------------|---------------------|------------|----------------|
| Black lignite, Wyo..... | 22.63 | 35.68 | 37.19 | 4.50 | 0.59 |
| Brown lignite, No. Dak. | 36.78 | 28.16 | 29.97 | 5.09 | 0.48 |
| Bituminous, Pa. . | 2.61 | 34.92 | 56.30 | 6.17 | 1.26 |
| Bituminous, Ill. . | 8.50 | 29.47 | 50.75 | 11.28 | 1.72 |
| Pocahontas, W. Va. (semi- bituminous). . . | 4.07 | 16.34 | 68.47 | 11.12 | 0.51 |
| Anthracite, Pa. (culm)..... | 5.41 | 7.02 | 71.79 | 15.78 | 0.74 |

TABLE 11.—Ultimate Analyses of Coal

| <i>Kinds of coal</i> | <i>Hydrogen</i> | <i>Carbon</i> | <i>Nitrogen</i> | <i>Oxygen</i> | <i>B. t. u.</i> |
|--|-----------------|---------------|-----------------|---------------|-----------------|
| Black Lignite, Wyo..... | 6.39 | 54.91 | 1.02 | 32.59 | 9734 |
| Brown Lignite, No. Dakota. . . | 6.93 | 41.87 | 0.69 | 44.94 | 7204 |
| Bituminous, Pa. . | 5.21 | 77.14 | 1.57 | 8.65 | 13,997 |
| Bituminous, Ill. . | 5.09 | 65.48 | 1.39 | 15.04 | 11,776 |
| Pocahontas, W. Va. (semi- bituminous). . . | 4.27 | 76.51 | 1.00 | 6.59 | 13,509 |
| Anthracite, Pa. (culm)..... | 3.10 | 72.65 | 0.77 | 6.96 | 12,047 |

¹ Selected from Professional Paper, No. 48, U. S. Geological Survey.

Relation of Composition to Calorific Power.—The only reliable and accurate method of ascertaining the calorific power of coal is by direct determination by burning in compressed oxygen in a bomb calorimeter. When this is impossible an approximation to the calorific power may be calculated from the chemical analysis. Calculation of calorific power from the ultimate analysis has generally been made by means of Dulong's formula:

$$\text{Calories per gram} = 8080 C + 34,500 (H - \frac{1}{8}O) + 2250 S.$$

This formula may be applied to the ultimate analysis either of the dry coal or of the coal containing moisture. The calorific powers thus determined are however in the majority of cases from 1 to 2 per cent too low,¹ while with soft coals and lignites the discrepancy may be considerably larger.

A better approximation to the true calorific power is obtained if the ultimate analysis be first corrected to the dry substance of the coal and then the calorific power of this dry substance estimated by the formula:

$$\text{Calories per gram} = 8080 (C - \frac{3}{8}O) + 34,500 H + 2250 S.$$

This formula gives results which average only slightly higher than the values obtained by means of the bomb calorimeter, the difference in the majority of cases being less than one per cent.¹

If only a proximate analysis is available the attempt to calculate the calorific power is subject to much larger errors, especially in the case of very soft coals—coals with a high proportion of volatile matter. Certain general relationships between the proximate composition have been determined and the *average* calorific power of the dry ash-free substance of coals of different proportions of volatile matter has been given by Sherman and Register as follows:¹

¹Sherman: Methods of Organic Analysis, Revised Edition, Chapter XII.

TABLE 12.—Approximate Average Calorific Power of the Dry Ash-free Substance of Coals with Different Proportions of Volatile Matter

| <i>Volatile matter in dry ash-free substance Per cent</i> | <i>B. t. u. per pound of dry ash-free substance</i> | <i>Volatile matter in dry ash-free substance Per cent</i> | <i>B. t. u. per pound of dry ash-free substance</i> | <i>Volatile matter in dry ash-free substance Per cent</i> | <i>B. t. u. per pound of dry ash-free substance</i> |
|---|---|---|---|---|---|
| 0 | 14,544 ¹ | 17 | 15,900 | 33 | 15,500 |
| 2 | 14,900 | 18 | 15,850 | 34 | 15,500 |
| 3 | 14,900 | 19 | 15,800 | 35 | 15,500 |
| 4 | 14,900 | 20 | 15,800 | 36 | 15,500 |
| 5 | 14,900 | 21 | 15,700 | 37 | 15,300 |
| 6 | 14,900 | 22 | 15,700 | 38 | 15,100 |
| 7 | 14,900 | 23 | 15,700 | 39 | 15,100 |
| 8 | 14,900 | 24 | 15,700 | 40 | 15,100 |
| 9 | 14,900 | 25 | 15,700 | 41 | 14,600 |
| 10 | 14,900 | 26 | 15,700 | 42 | 14,600 |
| 11 | 15,050 | 27 | 15,700 | 43 | 14,600 |
| 12 | 15,200 | 28 | 15,700 | 44 | 14,600 |
| 13 | 15,350 | 29 | 15,700 | 45 | 14,500 |
| 14 | 15,500 | 30 | 15,600 | 46 | 14,400 |
| 15 | 15,650 | 31 | 15,500 | 47 | 14,300 |
| 16 | 15,800 | 32 | 15,500 | 48 | 14,200 |

It is however to be emphasized that individual coals may show considerable variation from these average values particularly in cases where the proportion of volatile matter is high. For this reason it was not considered justifiable to tabulate the average relation for coals having over 48 per cent of volatile matter in the moisture- and ash-free substance. Among the 460 coal analyses coming within the range of the above table which were examined by Sherman and Register

¹Corresponding to 8080 calories per gram, the usually accepted value for carbon.

about one-half differed from the calorific powers indicated by the above table by less than 1 per cent and one-half by 1 per cent or more; about one-fourth differed by 2 per cent or more; about one-eighth by 5 per cent or more; one in seventeen by 4 per cent or more; one in twenty-seven by 5 per cent or more.

Thus in the majority of cases even a proximate analysis when interpreted as above may give an indication of the calorific power of considerable practical value to the engineer; but in cases in which an accurate knowledge of the calorific power is required only the results of careful determination with the bomb calorimeter should be accepted.

Fusibility of Coal Ash.—This is dependent upon the nature and conditions of the ash constituents of the coal and is important because of its bearing upon the matter of clinkering. Coal ash is usually high in silica or iron or both. At temperatures from 1000° to 1500° C. fused silicates of iron may cause serious clinkering. In coals containing pyrite the effect of heating may drive off about one-half the sulphur leaving a fusible residue which if the pyrite was in pieces of considerable size may start the formation of clinker. Since the other ash constituents also influence clinkering it is difficult to predict the behavior of the coal from its analysis and dependence is usually placed upon direct experimentation.

Adaptability of Coal to Given Conditions depends to some extent upon still other qualities of the coal and upon the method of firing, the matter of the grate, etc. The engineer and purchaser of coal must take into account the general nature of the coal and its adaptability to the particular conditions of its use, as well as its composition and calorific power.

Purchase of Coal under Specifications.—Coal has continued longer than other mine products to be sold on the basis of weight and reputation, but this condition is now rapidly passing and it is becoming increasingly common for coal to

be sold upon definite specifications and paid for according to its composition and heating value. The general character of the coal and its size are specified according to the conditions of its use. Beyond this the value will depend mainly upon the heating value and the ash content. Other things being equal the value of the coal to the consumer is directly proportional to its heating value. High ash content not only lowers the heating value but requires more attention in firing and more expense for handling of ashes. Typical specifications for the purchase of coal are given in detail in Bulletin 63 of the U. S. Bureau of Mines (1913).

Production of Coal in the United States has increased about ten-fold in the past forty years (Fig. 34). The estimates of quantity and value of coal produced by states during 1911 are shown on pages 128 and 129.

FIG. 34. Production of Coal in the United States.

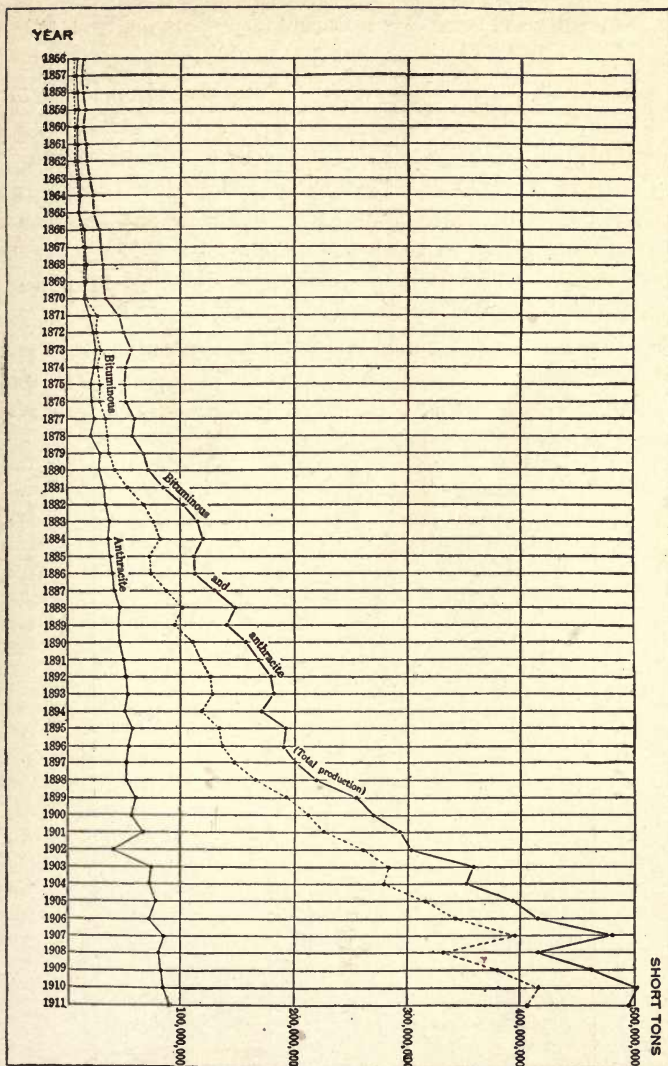

TABLE 13.—Rank of Coal-Producing States with Quantity and Value of Product and Percentage of Each in 1911—U. S. Geological Survey, Mineral Resources

| PRODUCTION | | | |
|-------------|---------------------------------|----------------------------------|---|
| <i>Rank</i> | <i>State or Territory</i> | <i>Quantity (short tons)</i> | <i>Percentage of total production</i> |
| 1 | Pennsylvania: | | |
| | Anthracite. | 90,464,067 | 18.2 |
| | Bituminous. | 144,754,163 | 29.2 |
| 2 | West Virginia. | 59,831,580 | 12.1 |
| 3 | Illinois. | 53,679,118 | 10.8 |
| 4 | Ohio. | 30,759,986 | 6.2 |
| 5 | Alabama. | 15,021,421 | 3.0 |
| 6 | Indiana. | 14,201,355 | 2.9 |
| 7 | Kentucky. | 13,706,839 | 2.8 |
| 8 | Colorado. | 10,157,383 | 2.0 |
| 9 | Iowa. | 7,331,648 | 1.5 |
| 10 | Virginia. | 6,864,667 | 1.4 |
| 11 | Wyoming. | 6,744,864 | 1.4 |
| 12 | Tennessee. | 6,433,156 | 1.3 |
| 13 | Kansas. | 6,254,228 | 1.3 |
| 14 | Maryland. | 4,685,795 | .9 |
| 15 | Missouri. | 3,760,607 | .7 |
| 16 | Washington. | 3,572,815 | .7 |
| 17 | New Mexico. | 3,148,158 | .6 |
| 18 | Oklahoma. | 3,074,242 | .6 |
| 19 | Montana. | 2,976,358 | .6 |
| 20 | Utah. | 2,513,175 | .5 |
| 21 | Arkansas. | 2,106,789 | .4 |
| 22 | Texas. | 1,974,593 | .4 |
| 23 | Michigan. | 1,476,074 | .3 |
| 24 | North Dakota. | 502,628 | .1 |
| 25 | Georgia and North Carolina. . . | 165,330 | } .1 |
| 26 | Oregon. | 46,661 | |
| 27 | California and Alaska. | 11,647 | |
| 28 | Idaho and Nevada. | 1821 | |
| | Total. | 496,221,168 | 100.0 |

VALUE

| <i>Rank</i> | <i>State or Territory</i> | <i>Value</i> | <i>Percentage of total value</i> |
|-------------|--------------------------------|---------------|--|
| 1 | Pennsylvania: | | |
| | Anthracite. | \$175,189,392 | 28.0 |
| | Bituminous. | 146,347,858 | 23.4 |
| 2 | Illinois. | 59,519,478 | 9.5 |
| 3 | West Virginia. | 53,670,515 | 8.6 |
| 4 | Ohio. | 31,810,123 | 5.1 |
| 5 | Alabama. | 19,079,949 | 3.0 |
| 6 | Indiana. | 15,326,808 | 2.4 |
| 7 | Colorado. | 14,747,764 | 2.4 |
| 8 | Kentucky. | 13,617,217 | 2.2 |
| 9 | Iowa. | 12,663,507 | 2.0 |
| 10 | Wyoming. | 10,508,863 | 1.7 |
| 11 | Kansas. | 9,645,572 | 1.5 |
| 12 | Washington. | 8,174,170 | 1.3 |
| 13 | Tennessee. | 7,209,734 | 1.2 |
| 14 | Missouri. | 6,431,066 | 1.0 |
| 15 | Oklahoma. | 6,291,494 | 1.0 |
| 16 | Virginia. | 6,254,804 | 1.0 |
| 17 | Montana. | 5,342,168 | .9 |
| 18 | Maryland. | 5,197,066 | .8 |
| 19 | New Mexico. | 4,525,925 | .7 |
| 20 | Utah. | 4,248,666 | .7 |
| 21 | Arkansas. | 3,396,849 | .5 |
| 22 | Texas. | 3,273,288 | .5 |
| 23 | Michigan. | 2,791,461 | .4 |
| 24 | North Dakota. | 720,489 | .1 |
| 25 | Georgia and North Carolina . . | 246,448 | .1 |
| 26 | Oregon. | 108,033 | |
| 27 | California and Alaska. | 23,297 | |
| 28 | Idaho and Nevada. | 4872 | |
| | Total. | \$626,366,876 | 100.0 |

ARTIFICIAL SOLID FUELS

In addition to charcoal, coke, briquetted fuel, several minor solid fuels such as sawdust, bagasse, and spent tan will be discussed under this head.

Charcoal is the residual product of the destructive distillation of wood (See Chap. IV) and its composition is dependent upon the temperature of carbonization as may be seen from the percentage of carbon at various temperatures given in the following table:¹

| <i>Temperature of Carbonization</i> ° C. | <i>Carbon Per cent</i> |
|---|----------------------------|
| 150 | 47.51 |
| 250 | 65.59 |
| 350 | 76.64 |
| 432 | 81.64 |
| 1023 | 81.97 |

Its composition, however, varies with the different woods. The ultimate analysis of a dried sample of a commercial charcoal gave the following results:

| | <i>Per cent</i> |
|-------------------|-----------------|
| Carbon. | 83.0 |
| Hydrogen. | 2.7 |
| Oxygen. | 13.2 |
| Ash. | 1.1 |

The proximate analysis of a commercial sample (without being dried) gave the following results:

| | <i>Per cent</i> |
|-----------------------------|-----------------|
| Fixed carbon. | 90.7 |
| Volatile matter. | 4.2 |
| Moisture. | 3.2 |
| Ash. | 1.7 |
| B. t. u. per pound. | 13,650 |

¹ Harper: Utilization of Wood Waste by Distillation, p. 133.

Charcoal has a low specific gravity, about 0.20. It is porous, quite brittle, and retains the form and shows the structure of the wood from which it was made. It contains about one-half of the original carbon of the wood and has about 80 per cent of the original volume. It ignites readily and burns without flame.

As a fuel charcoal has long been used in metallurgical operations. On account of its freedom from sulphur and phosphorus it has found especial application in the production of the high grade iron known as Swedish iron (q. v.). It has also proved a very desirable fuel in restaurants for broiling meats and to a limited extent has been used, sometimes in the briquetted form, as a domestic fuel. Aside from its use as a fuel it has many minor uses such as a constituent of gunpowder, in foundry facing mixtures and for decolorizing and clarifying oils and solutions.

Coke is the residual product of the destructive distillation of coal, the yield in the beehive ovens being about 63 per cent, and in by-product ovens about 80 per cent of the weight of the coal. Its relation to coal may be noted by a comparison of the average analyses for the month of July (1907) in a Semet Solvay plant of the coal and resulting coke:

| | <i>Coal</i> <i>Per cent</i> | <i>Coke</i> <i>Per cent</i> |
|--------------------------|--------------------------------|--------------------------------|
| Moisture. | 1.34 | 2.5 |
| Volatile matter. | 24.35 | 1.3 |
| Fixed carbon. | 67.95 | 86.30 |
| Ash. | 7.75 | 12.40 |
| Sulphur. | 0.92 | 1.31 |
| Phosphorus. | 0.009 | 0.011 |

The high percentage of moisture in these analyses is due to the necessity of quenching the coke with water when it is discharged from the retort.

Coke is gray black in color, porous, brittle, and has a slight metallic luster and ring. It is used in metallurgical operations, for which purpose it must be hard and capable of bearing a heavy burden in the furnace. Its calorific power is about 14,000 B. t. u. per pound. Coke is also a product of the illuminating gas industry and is used to some extent as a domestic fuel in some localities. The production of coke has been discussed in the preceding chapter.

Briquetted Fuels.—The accessibility of coal and other fuels has made it heretofore unnecessary to make use of the various artificially prepared fuels of this type in this country. In Germany, however, briquettes made of cheap bituminous coal such as screenings or mine run, with coal tar as a binder sell at from \$2.92 to \$5.16 per ton¹ and compete with other fuels. In Belgium briquetted fuel has been largely used for firing locomotives.

The kind of binder used has much to do with successful briquetting. A very complete description of the various binders that may be used is given in Bulletin 24 of the United States Bureau of Mines. From a practical standpoint heavy bituminous substances such as asphalt and coal tar pitch are most commonly employed. Inorganic binders such as Portland cement, magnesium hydroxide, etc., have been proposed but frequently are impracticable on account of the high ash content of the briquettes.

The usual method of briquetting consists in the powdering of the fuel, mixing the powder with the binder, heating to the melting point of pitch (about 180° C.), and then molding the mixture into blocks under pressure. The machine used at the fuel testing plant of the United States Geological Survey at St. Louis produces briquettes of cylindrical form with rounded ends, averaging one-half pound in weight. It molds briquettes under a pressure of 1200 pounds per square inch and produces about five tons per hour.

¹ *Eng. News*, 56, 256 (1906).

Peat, petroleum residues obtained from oil refining or in gas manufacture, and other combustibles are briquetted in the same manner as coal, but the use of briquetted fuel is not yet extensive in this country.

MINOR SOLID FUELS

Sawdust is a waste product of the sawmill. Every 1000 feet of finished lumber yields 35 to 50 cubic feet of sawdust and one-fourth cord of slabs. The disposal of these by-products requires usually the labor of 7 per cent of the employees. Tests made by the Portland Cordage Works ¹ show the efficiency of sawdust as a fuel. The results of these tests are given in the cost of the various fuels per horse power hour and are as follows:

| | |
|-------------------------------|--------|
| 1. Oil. | \$0.72 |
| 2. Sawdust. | 0.43 |
| 3. Sawdust and slabs. | 0.50 |
| 4. Slabwood. | 0.62 |

Sawdust as generally used contains a high amount of moisture and yields, therefore, a low calorific power. Its economy as a fuel lies largely in the ease with which it may be handled, being generally conveyed by air blowers and fed into the fire boxes through flues. The statements regarding composition and calorific power of wood (above) apply usually to sawdust. The economical use of sawdust as a fuel may require special arrangement of the grates and firing.

Bagasse, or megass, is a product of the sugar plantation consisting of the sugar cane after the juice has been extracted. Many sugar houses depend entirely upon their bagasse for fuel. In the United States this is about 10 per cent of the cane. Its calorific value varies from 8000 to 3000 B. t. u.

¹ *J. Elec. Pwr. Gas*, 15, 445 (1905).

per pound, being similar to that of wood and depending largely upon the moisture content.

Spent Tan is a waste product of the tannery consisting of the fibrous portion of bark. It is a wet fuel containing usually from 50 to 65 per cent of water. Its calorific power depends chiefly upon the extent to which it is dried before using, the solids of the spent tan being similar in fuel value to the solids of the corresponding species of wood. The use of spent tan and similar "waste fuels" is ably discussed by D. M. Myers in the *Engineering Magazine* for April, May and June, 1913.

REFERENCES

I

- BEMENT:** Economical Burning of Coal Without Smoke.
GILL: Gas and Fuel Analysis for Engineers.
GISSING: Commercial Peat.
KEMP: Economic Geology of the Non-Metallic Minerals.
PARKER: Production of Coal in 1910. U. S. Geol. Survey (includes a classified list of the papers dealing with coal, coke, lignite and peat contained in the publications of the U. S. Geol. Survey); also Production of Coal in 1911.
SHERMAN: Methods of Organic Analysis (Revised Edition).
SOMERMEIER: Coal; its Composition, Analysis, Utilization and Valuation.
GEOLOGICAL SURVEY (OHIO): Coal. Fourth Series, Bulletin 9.
GEOLOGICAL SURVEY (WEST VIRGINIA): Coal Report, Vol. II.
GEOLOGICAL SURVEY (WEST VIRGINIA): Supplementary Coal Report, Vol. IIA.
U. S. BUREAU OF MINES:
 Bulletin 1. The Volatile Matter of Coal.
 " 3. The Coke Industry of the United States as Related to the Foundry.
 " 6. Coals Available for the Manufacture of Illuminating Gas.
 " 14. Briquetting Tests of Lignite at Pittsburg (with a chapter on sulphite pitch binder).
 " 16. The Uses and Value of Peat.
 " 23. Steaming Tests of Coals and Related Investigations.

- Bulletin 24. Binders for Coal Briquets (reprint of Bulletin 343, U. S. Geol. Survey).
- “ 29. The Effect of Oxygen in Coal (reprint of Bulletin 382, U. S. Geol. Survey).
- “ 41. The Purchase of Coal under Specifications.
- “ 63. Sampling Coal Deliveries and Specifications for the Purchase of Coal.
- Technical Paper 2. The Escape of Gas from Coal.
- “ “ 5. The Constituents of Coal Soluble in Phenol.
- “ “ 8. Methods of Analyzing Coal and Coke.

II

- LORD AND HASS: Calorific Power of American Coals. *Trans. Amer. Inst. Mining Engineers*, 27, 259, 946 (1897).
- ALLEN: Relative Values of Fuels used on Pacific Coast. *Mining Sci. Press*, 81, 569 (1900).
- LONGMUIR: Present Day Metallurgical Fuels. *Iron Coal Trades Rev.*, 34, 26 (1901).
- WILLEY: American Soft Coal. *Cassier*, 19, 430 (1901).
- PARKER: Testing of Coals and Lignites at St. Louis World's Fair. *Eng. Mag.*, 29, 19, 211 (1905).
- DOANE: Testing and Purchasing Coal for Steam Plants. *Eng. News*, 57, 146 (1906).
- GOODRICH: The Utilization of Low Grade Fuels for Steam Generation. *Eng. Mag.*, 30, 346, 528 (1906).
- JUDD: Beehive Coke Oven Practice. *Iron Age*, 79, 190 (1906).
- JUDD: By-product Plants. *Iron Age*, 79, 406 (1906).
- MACFARLAND: Powdered Coal Firing for Steam Boilers. *Eng. Mining J.*, 81, 901 (1906).
- TROBRIDGE: Gases Enclosed in Coal and Certain Coal Dusts. *J. Soc. Chem. Ind.*, 25, 1129 (1906).
- FRANKFORTER: Lignites of the Northwest. *J. Am. Chem. Soc.*, 29, 1488 (1907).
- VORHEES: Methods of Testing Coal. *Proc. Am. Soc. Testing Materials*, 7, 560 (1907).
- NYSTROM: Peat and Lignite; their Manufacture and Uses in Europe. Canada, Dept. of Mines, p. 247 (1908).
- PARR AND HAMILTON: Weathering of Coal. *Econ. Geol.*, 2, 693 (1908).
- BLAKELY AND CHANCE: A Rapid Method for Determination of Specific Gravity of Coal. *J. Ind. Eng. Chem.*, 1, 812 (1909).
- EMERSON: A New Bomb Calorimeter. *J. Ind. Eng. Chem.*, 1, 17 (1909).

- HAANEL: Modern Methods of Manufacturing Charcoal. *Iron Coal Trades Rev.*, October 27 (1909).
- BENSON: A Method for Increasing the Calorific Power of Washington Lignites. *Met. Chem. Eng.*, **8**, 684 (1910).
- DAVIS: Peat as a Source of Chemical Products. *Eng. Mag.*, **39**, 253 (1910).
- MYERS: Tan Bark as a Boiler Fuel. *School of Mines Quarterly*, **31**, 116 (1910).
- MOLDENKE: Specifications for Foundry Coke. *Met. Chem. Eng.*, **8**, 400 (1910).
- PORTER AND OVITZ: Losses in the Storage of Coal. *J. Ind. Eng. Chem.*, **2**, 77 (1910).
- WRIGHT: Fuel Briquetting Industry. *Eng. Mag.*, **39**, 47, 195 (1910).
- FRANKFORTER and PETERSON: A Chemical Study of Lignite. *J. Am. Chem. Soc.*, **33**, 1954 (1911).
- KENT AND ALLEN: Formula for Purchase of Coal on Heat Unit Basis. *Eng. News*, **65**, 108 (1911).
- KERSHAW: The Purchase of Fuel on a Heat Unit Basis in Germany and Switzerland. *Met. Chem. Eng.*, **9**, 427 (1911).
- AYERS: Technical Problems of Coal Preparation. *Proc. 8th Intern. Congr. Appl. Chem.*, **10**, 33 (1912).
- BABCOCK: Utilization of Non-coking Low Grade Lignitic Coals. *Proc. 8th Intern. Congr. Appl. Chem.*, **10**, 41 (1912).
- COX: Oxidation and Deterioration of Coal. *Ibid.*, **10**, 109 (1912).
- DELAMATER: Coal Washing Efficiency. *Ibid.*, **10**, 129 (1912).
- FRAZER AND HOFFMAN: The Constituents of Coal Soluble in Phenol. U. S. Bureau of Mines, Technical Paper 5 (1912).
- LUCKE: Fuel Economy in Factories. *J. Ind. Eng. Chem.*, **4**, 58 (1912).
- POPE: Government Coal Purchases under Specifications. U. S. Bureau of Mines, Bull. 41 (1912).
- POPE: Sampling Coal Deliveries, and Types of Government Specifications for the Purchase of Coal. U. S. Bureau of Mines, Bull. 63 (1913).
- PORTER AND OVITZ: Deterioration and Spontaneous Heating of Coal in Storage. *J. Ind. Eng. Chem.*, **4**, 5 (1912).
- PORTER AND OVITZ: The Spontaneous Combustion of Coal. *Proc. 8th Intern. Congr. Appl. Chem.*, **10**, 251 (1912).
- STANTON AND FIELDNER: Analyses of Coal Samples from Various Fields in the United States. U. S. Geol. Survey, Bull. 471 (1912).
- WRIGHT: The Briquetting of American Lignites. *Proc. 8th Intern. Congr. Appl. Chem.*, **10**, 317 (1912).
- STEVENSON: Formation of Coal Beds. *Proc. Amer. Phil. Soc.*, **51**, 423 (1913).

CHAPTER VI

LIQUID AND GASEOUS FUELS

IN addition to the fuels considered in the preceding chapter various natural and artificial liquids and gases are used industrially to a large extent for fuel purposes. Among the liquids thus utilized are petroleum oil, shale oil, tar, and alcohol, while the gaseous mixtures thus employed may be either natural gas or the gases obtained from the various processes hereafter described.

LIQUID FUELS

The economic advantages of liquid fuels over solid fuels consist in the greater "heat density" (i. e., quantity of heat contained in unit volume), in the higher boiler efficiency brought about by more perfect combustion, in the attainment of higher temperatures since less excess air is required, in the ease of manipulation and control in firing (stoking), in the absence of ash, and in the elimination of the dust and smoke which usually accompany coal firing.

Petroleum Oil.—The general composition and character of the various petroleum oils will be discussed in a later chapter (q. v.). Petroleum in a crude form may be used for fuel purposes; or the light oils (gasolines) may be removed by distillation and the residue used for fuel; or residues from oils used in the production of refined products, may be used. If it is a crude oil, the specifications under which it is bought usually provide limitations as to the amount of water and earthy matter it may carry. A determination of water and dirt may be readily made by placing 30 cc. of the oil in a

100 cc. glass stoppered graduated cylinder; 23 cc. of benzene (C_6H_6), are next added and thoroughly shaken; after which the cylinder is filled up to the 100 cc. mark with ordinary gasoline, well shaken, and allowed to stand twenty-four hours. The water and dirt will settle to the bottom, each 1 cc. of this bottom layer representing 2 per cent of foreign matter in the oil.

For example, the United States Government specifications prescribe among others the following: Fuel oil shall not flash below $60^\circ C.$ ($140^\circ F.$); specific gravity shall be from 0.85 to 0.96 at $15^\circ C.$ ($59^\circ F.$); it must be sufficiently mobile to flow through 4" pipe 10 feet in length under head of 1 foot of oil; it should not congeal at $0^\circ C.$; its calorific power must not be less than 18,000 B. t. u.; and it will be rejected if it contains more than 2 per cent moisture and 1 per cent sulphur.

The composition of some typical petroleum used for fuel was as follows:

| <i>Locality</i> | <i>Carbon</i> | <i>Hydrogen</i> | <i>Oxygen and nitrogen</i> | <i>Sulphur</i> | <i>B. t. u. per pound</i> |
|---------------------|---------------|-----------------|------------------------------------|----------------|-----------------------------------|
| Russia. | 84.94 | 13.96 | 1.25 | | 18,611 |
| Texas. | 85.66 | 11.03 | 3.31 | | 19,242 |
| California. | 86.32 | 10.72 | 2.09 | 0.870 | 18,900 |

The physical characteristics of a few California ¹ crude oils are given in the table below:

| <i>Field</i> | <i>Color</i> | <i>Beaumé density at 60° F.</i> | <i>Flash point ° F.</i> | <i>Burning point ° F.</i> | <i>Viscosity at 60° F.</i> |
|----------------------|--------------|---|---------------------------------|-----------------------------------|--------------------------------|
| Sunset. | Black | 14.4° | 260 | ... | 716 |
| Los Angeles. | " | 13.0 | 260 | 343 | 1004 |
| Kern River. | " | 15.6 | 253 | 282 | 341.7 |

¹ Bulletin 32, California State Mining Bureau (1904).

From these data it will be noted that petroleum fuel represents essentially a mixture of compounds of carbon and hydrogen (the oxygen being regarded as due chiefly to water and other impurities) together with varying small quantities of sulphur compounds. It thus possesses the requisites of a very efficient fuel. Its low specific gravity and high viscosity, however, require the use of some suitable mechanism for atomizing or breaking up the oil into fine particles. The necessity of this may be seen from a consideration of what takes place in ordinary distillation which leaves behind a coke residue. In a similar way when a particle of oil leaves the nose of the burner it immediately begins to evaporate in the high heat of the furnace and, if the drop is very small, the liquid part will be completely changed to gas and a tiny speck of carbon or coke will be left. If this is still in the zone of combustion, it too will be burned. If, however, the drop of

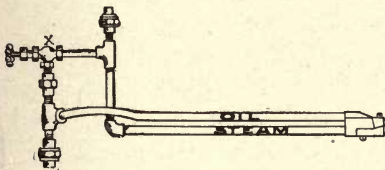

FIG. 35. Commercial Type of Fuel Oil Burner.

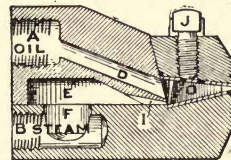
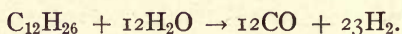

FIG. 36. Section through mixing Device of a Fuel Oil Burner.

oil is too large to evaporate completely in the time it takes to travel across the furnace, the residue will be projected against whatever solid body happens to be in its way and will either stick there or be projected from the furnace stack as smoke. To overcome this loss of heat and formation of smoke, oil burners are provided with a stream of air or steam so arranged that the oil will be broken up into the finest possible spray (Figs. 35 and 36). Various types of burners are in practical use, but Figure 36 illustrates the general principle on which oil burners are operated. The oil is admitted

at *A*, flows through *D* into the mixing and atomizing chamber, *C*; steam enters at *B*, passes through *F* and *E* into the mixing chamber *C* where it cuts across the oil at an angle. The oil and steam are there mixed and the pressure of the steam throws the oil far out into the space where it enters into combustion with the air.

The use of steam is often thought to give better results since its presence seems to decompose the oil into simpler gases, according to the reaction between the oil and steam, the oil being regarded roughly as having the approximate composition given:



From the thermo chemical data given later it will be seen, however, that the decomposition of water absorbs heat and the heat balance will therefore not be changed whether the oil be burned alone with air, or whether it be decomposed by steam and the products then burned. In the cement kilns (Chapter XII) where long fire flues are present, air is used to atomize the oil and has given excellent results.

Oil is used as a fuel in the firing of locomotive and steamship boilers, in numerous manufacturing industries, and is beginning to find application in domestic heating.

Since American petroleum is essentially mixtures of hydrocarbons and chiefly of the methane series, it is to be expected that the higher the specific gravity of the sample the greater will be the mean molecular weight and percentage of carbon and the less will be the percentage of hydrogen and the heat of combustion per gram. In general a specific gravity of

| | | | | | | |
|------|--------|-----------------|---------------|-------------------|---|---|
| 0.7 | -0.75 | indicates about | 11,500-11,300 | calories per gram | | |
| 0.75 | -0.8 | " | " | 11,300-11,100 | " | " |
| 0.8 | -0.85 | " | " | 11,100-10,900 | " | " |
| 0.85 | -0.9 | " | " | 10,900-10,700 | " | " |
| 0.9 | -0.933 | " | " | 10,700-10,500 | " | " |

More commonly in English-speaking countries the density of petroleum oils is stated in terms of the Baumé scale and the calorific power in British thermal units. The relations of the values are as follows:

$$\text{Calories per gram} \times 1.8 = \text{B. T. U. per pound}$$

$$\text{Specific gravity} = \frac{140}{150 + B^\circ}$$

From the densities and calorific powers of 86 samples of American petroleum oils ranging from very heavy crude oils to light gasoline the following table ¹ has been constructed:

TABLE 14.—Approximate Calorific Powers, in British Thermal Units, of Petroleum Oils of 20° to 67° Baumé

| <i>Density degrees Baumé</i> | <i>Calorific power B. t. u. per pound</i> | <i>Density degrees Baumé</i> | <i>Calorific power B. t. u. per pound</i> | <i>Density degrees Baumé</i> | <i>Calorific power B. t. u. per pound</i> |
|--------------------------------------|---|--------------------------------------|---|--------------------------------------|---|
| 20 | 18,930 | 36 | 19,735 | 52 | 20,220 |
| 21 | 18,990 | 37 | 19,770 | 53 | 20,245 |
| 22 | 19,050 | 38 | 19,805 | 54 | 20,270 |
| 23 | 19,110 | 39 | 19,840 | 55 | 20,290 |
| 24 | 19,170 | 40 | 19,875 | 56 | 20,310 |
| 25 | 19,225 | 41 | 19,910 | 57 | 20,330 |
| 26 | 19,280 | 42 | 19,940 | 58 | 20,350 |
| 27 | 19,335 | 43 | 19,970 | 59 | 20,370 |
| 28 | 19,390 | 44 | 20,000 | 60 | 20,390 |
| 29 | 19,445 | 45 | 20,030 | 61 | 20,410 |
| 30 | 19,495 | 46 | 20,060 | 62 | 20,430 |
| 31 | 19,545 | 47 | 20,090 | 63 | 20,450 |
| 32 | 19,590 | 48 | 20,120 | 64 | 20,470 |
| 33 | 19,630 | 49 | 20,145 | 65 | 20,490 |
| 34 | 19,665 | 50 | 20,170 | 66 | 20,510 |
| 35 | 19,700 | 51 | 20,195 | 67 | 20,530 |

In over nine-tenths of the cases examined, the values determined by the bomb calorimeter and those estimated from

¹ Sherman's Methods of Organic Analysis, Revised Edition, p. 248.

the above table agreed within one per cent. The oil must of course be reasonably free from water and dirt before determining the density.

It will be noted that the variations in heating value among petroleum oils is very much less than that among coals.

Other liquids used for fuel purposes are *shale oil* made in Scotland from the destructive distillation of bituminous shales; *coal tar* or *water gas tar* obtained as by-products in gas manufacture; *wood tar* from the destructive distillation of wood; and *alcohol* produced by the fermentation of plant substances containing starch or sugar.

Shale oil has a dark green color and a specific gravity of 0.860 to 0.890. A typical specimen yielded on distillation the following products, the "burning oil" being used for illuminating purposes and the "heavy oil" constituting the fuel oil:

| | |
|----------------------|------------|
| Naphtha. | 6 per cent |
| Burning oil. | 32 " |
| Heavy oil. | 24 " |
| Paraffin. | 12 " |
| Loss. | 26 " |

The tar obtained in the manufacture of gas is sometimes used as a liquid fuel but is quite unsatisfactory. On account of the solid matter which it contains it produces a smoky flame, and it is handled with difficulty.

Wood tar constitutes a fuel in the acetic acid industry being burned chiefly under the retorts used in the distillation of the hard woods such as oak and ash. It is burned in the same manner as oil and gives very satisfactory results.

Alcohol is used chiefly as a vaporized fuel (as described below) but is employed to some extent in stoves used in cooking and for heating purposes. It burns without smoke and has a fairly high heat value.

GASEOUS FUELS

The advantages of gaseous fuels over solid fuels are similar to those considered in connection with liquid fuels, consisting in the absence of residues (ash) and in the ease of regulation of temperature, length of flame, and air supply. Gaseous fuels permit of a higher temperature of combustion than in the case of liquid fuels, since it is possible to preheat the air and often the gas before these two components reach the place of combustion, and the absorption of heat for this purpose is therefore lessened.

The industrial gases originate from a variety of sources and processes and may conveniently be described as (1) natural gas, (2) gas from the destructive distillation of coal, (3) reduction or water gas, (4) incomplete combustion or producer gas, (5) gas from decomposition of carbides, as acetylene, and (6) gases from vaporization of liquids as oil gas, Blau gas, etc.

TABLE 15.—Approximate Average Composition of Commercial Gases
(Compiled from Various Sources)

| | <i>Natural gas</i> | <i>Coal gas</i> | <i>Coke oven gas</i> | <i>Producer gas (Mond)</i> | <i>Blast furnace gas</i> | <i>Water gas</i> |
|---|--------------------|-----------------|----------------------|----------------------------|--------------------------|------------------|
| Hydrogen. p. ct. | 1.9 | 46.0 | 53.0 | 25.0 | 3.0 | 46.0 |
| Methane. " | 93.0 | 35.0 | 30.0 | 3.0 | | 2.0 |
| Ethylenes. " | 0.2 | 6.0 | 3.0 | | | |
| Carbon monoxide. " | 0.6 | 8.0 | 7.0 | 13.0 | 28.0 | 45.5 |
| Carbon dioxide. " | 0.2 | 3.0 | 2.0 | 13.0 | 10.0 | 4.0 |
| Oxygen. " | 0.3 | 0.6 | | | | 0.5 |
| Nitrogen. " | 3.8 | 1.4 | 5.0 | 46.0 | 59.0 | 2.0 |
| B. t. u. per cubic foot | 1000. | 660. | 580. | 164. | 108. | 340. |
| Cubic feet per horse- power hour " | 12 | 15 | 18 | 80 | 100 | |
| Mixture, air to gas. | 8-1 | 6-1 | 5-1 | 1-1 | 1-1¼ | |

The composition and heat values of the principal commercial gases and of their component parts is given in Tables 15 and 16.

TABLE 16.—Heat Value of Component Parts

| | <i>B. t. u.</i> <i>per</i> <i>cubic feet</i> | <i>B. t. u.</i> <i>per</i> <i>pound</i> | <i>Mixture,</i> <i>air to</i> <i>gas</i> |
|-----------------------------|--|---|--|
| Hydrogen..... | 348. | 62,100 | 2.4-1 |
| Methane..... | 1065. | 23,850 | 9.6-1 |
| Ethylene ¹ | 1673. | 21,440 | 14.4-1 |
| Carbon monoxide..... | 349. | 4,470 | 2.4-1 |

The mixture of air and gas indicated in these tables refers to the *theoretical volume* of air which must be supplied in order completely to oxidize the corresponding combustible or mixture of combustibles.

Natural Gas.—The industrial importance of natural gas is only less than that of petroleum and coal when considered from the standpoint of a fuel. In 1909, about half a trillion cubic feet of natural gas, representing a value of \$63,207,000 were consumed. Of this amount more than sixty per cent was produced in the gas fields lying within the Appalachian and Lima-Indiana oil regions (q. v.). The discussion which follows will therefore be based upon the character and properties of the crude natural gas obtained from these regions. The composition of natural gas is indicated from the following analyses:²

¹ Propylene yields 2500 B. t. u. per cubic foot or 21,400 B. t. u. per pound. The "illuminants" in gas are sometimes counted as a mixture of ethylene and propylene and the B. t. u. per cubic foot as 2000 which is about the mean of the two gases (Stillman).

² From U. S. Geol. Survey Bulletin 491, p. 683.

| | <i>Pittsburg, Penna., gas</i> | <i>Indiana & Ohio gas</i> | <i>Kansas gas</i> |
|------------------------------|---------------------------------------|---------------------------------------|-----------------------|
| Methane..... | | 93.36 | 97.63 |
| Paraffins ¹ | 98.90 | | |
| Ethylene..... | | .28 | .22 |
| Carbon monoxide..... | | .53 | 1.32 |
| Carbon dioxide..... | .40 | .25 | .22 |
| Hydrogen..... | None | 1.76 | |
| Nitrogen..... | .70 | 3.28 | .60 |
| Hydrogen sulphide..... | None | .18 | |
| Oxygen..... | None | .29 | Trace |

It will be seen from the above table that the natural gas of the Pennsylvania fields is not a complex mixture, as commonly regarded, but is composed of paraffin hydrocarbons with carbon dioxide and nitrogen as impurities. The gases which emanate from wells under sufficient pressure to be piped to distant points for consumption consist principally of methane (CH_4), and ethane (C_2H_6). The gases that issue from old wells in which the pressure has diminished often contain propane (C_3H_8), and butane (C_4H_{10}), while in wells where the gas is withdrawn under diminished pressure (i. e., 12 to 13 pounds below that of the atmosphere), a liquid product is obtained which resembles gasoline in its general nature.

Natural gas may be divided into two great classes: (1) the so-called "dry gas," or the natural gas of commerce, and (2) "wet gas," or gas saturated with easily liquefiable vapors. The latter has been made the basis of a very interesting application known as the "natural gasoline" industry and has given rise to a number of commercial gases, which may be conveniently described before proceeding to the discussion of the fuel properties of natural gas proper.

As already indicated some gases contain methane only and

¹ Chiefly methane (CH_4) with more or less ethane (C_2H_6).

such gases are not adapted to the production of liquefied products. Since ethane requires 664 pounds to the square inch at 35° C. to liquefy it, a mixture of methane and ethane would likewise prove unsatisfactory for liquefaction from a commercial standpoint. If, however, a "wet gas" containing higher hydrocarbons be liquefied, it is probable that much of the ethane will go into solution in the liquefied hydrocarbons.

The fractions which may be obtained from the liquefied "wet gas," either during or after liquefaction, are as follows:

(1) A gaseous product, the common natural gas of commerce; (2) a semi liquid product known as the "wild" product which should be regarded as a liquefied gas and confined in high pressure steel containers only; (3) light liquid product, or light gasoline used for blending with heavy naphthas; and (4) a heavy liquid product, or ordinary high grade gasoline.

Various attempts have been made in the past to liquefy or compress gases so that they may be readily transported and used in small towns, hotels, and country residences for the same purposes as the ordinary city gas is used. These efforts have in general been directed toward breaking up or "cracking" the heavy hydrocarbons of shale oil and petroleum by projecting them against heated surfaces, thereby causing them to become "permanent" gases. By subjecting mixtures of such gases to high pressures and low temperatures they may be liquefied and retained in heavy steel cylinders under pressure of 10 to 12 atmospheres. The gas is delivered by means of a reducing valve at low pressure for domestic use. Pintsch¹ gas is prepared in this manner and has found extensive use in the lighting of railway trains. Among similar processes recently developed may be mentioned those of Blau² and the Swiss Liquid Gas Company.³

¹ Butterfield: Gas Manufacture, Vol. 1, p. 230.

² *Zeit. f. angew. Chem.* (1905), p. 671, and *Chem. Abs.*, 2, 3402 (1908).

³ *Chem. Eng.*, 10, 122 and *Chem. Abs.*, 4, 102 (1910).

The properties of the more important gases of this type are given in the table ¹ below:

| | Specific gravity (air) | Heat value per cubic feet B. t. u. | Candle power burning 3 cu. ft. per hr. | Unsaturated hydrocarbons | Saturated hydrocarbons | Hydrogen | Carbon monoxide | Carbon dioxide | Oxygen | Nitrogen |
|---------------------------|------------------------|------------------------------------|--|--------------------------|------------------------|----------|-----------------|----------------|--------|----------|
| Natural gas. | .64 | 1189 | | | 99.00 | | 0.40 | | | 0.50 |
| Liquefied natural gas ... | 1.25 | 1800 to 3300 | 45-50 | | 99.00 | | | | | |
| Pintsch gas. | | 1500 | 45-50 | 35.65 | 45.37 | 12.44 | 0.60 | 0.74 | 2.00 | 3.00 |
| Blau gas ... | .94 | 1700 | 108 ² | | | | | | | |

Natural gas is used for manufacturing and industrial purposes as well as in domestic consumption. Large quantities are used in the manufacture of carbon black which is used as a paint pigment. The principal use of natural gas, however, is as a fuel for heating and in the generation of power by means of both the steam engine and gas engine. It is transported to distant points in pipe lines and sells from 1¼ cents per thousand cubic feet at the well to 27 cents delivered to the consumer.

Destructive Distillation Gases.—The general process of destructive distillation has been described in Chapter IV. The nature of the products obtained by heating coal in closed retorts is dependent upon the kind of coal, the temperature

¹ Technical Paper No. 10, U. S. Bureau of Mines (1912).

² When used in an inverted mantle.

of distillation, and the rate of heating.¹ Formerly coal gas was used much more for lighting than for heating and was said to be composed of three types of gases: (1) "illuminants," (2) so-called "dilutents," and (3) impurities. The "illuminants" are chiefly unsaturated hydrocarbons like ethylene (C_2H_4), acetylene (C_2H_2), and benzene (C_6H_6), which impart to gas its luminous properties. The "dilutents," methane, hydrogen, and carbon monoxide, are the principal sources of the heat of combustion. The impurities which are usually nitrogen, carbon dioxide, and hydrogen sulphide (sometimes carbon disulphide), are deleterious in effect. The proportions in which these classes are present vary with the purpose for which the gas is wanted, but may be estimated at about 6.5 per cent illuminants, 90 per cent "dilutents," and 3.5 per cent impurities.

The Manufacture of Coal Gas.—Coal gas is made by two methods: (1) distillation of soft coal in fire clay retorts heated from underneath, and (2) distillation of coal in the by-product coke process previously described.

The retorts used in gas works consist of an arched chamber of fire clay, usually 26 inches wide, 16 inches high, and 8 to 10 feet long. The walls are $2\frac{1}{2}$ inches thick. A set of nine retorts constitutes a bench, protected by a fire-brick construction. Underneath the bench is an oven heated by coke. The hot gases from it rising upward are mixed with heated air, and play upon the exterior surface of the retorts.

Each retort is fitted with a tightly closing cast iron mouth-piece and lid through which it is charged with about 400 pounds of coal at a time. During the process of distillation the gases from the coal are led away by pipes to the hydraulic main. The hydraulic main is a large pipe connecting with the pipes from each retort by means of a water or tar seal. The

¹ For tables and discussion see Bulletin 1, The Volatile Matter of Coal, U. S. Bureau of Mines.

gas next passes through a series of pipes serving as condensers and is cooled. In these condensers much of the tar is also removed. The gas then passes through the scrubbers, which are tall towers packed with wooden perforated plates over which water percolates from a supply on top of the tower whilst the gas passes upward. Instead of scrubbers, "washers" are often used, in which the gas is freed from its ammonia and tar by being bubbled through water.

For the purpose of removing the carbon dioxide and hydrogen sulphide, the gas next passes into the purifiers, where it is brought in contact with moist slaked lime or more commonly hydrated oxide of iron.

The purified coal gas is next stored in holders and distributed for use. In the United States it is not customary to sell coal gas by itself but it is usually mixed with other gases, the mixture going under the name of illuminating gas. The latter, however, serves also as a domestic fuel in various types of gas stoves and hot water heaters. Even as an illuminant its value at the present time is largely coincident with its fuel value, since the introduction of Welsbach mantles requires a heat of combustion sufficiently great to maintain the oxides composing the mantle at incandescence. In other words, the light emitted from the incandescent mantle is utilized instead of that obtained from carbon particles. The effectiveness of the mixture of thorium and cerium oxides of which the mantle is essentially composed is seen from the fact that when a given amount of gas is burned in a burner equipped with a Welsbach mantle it emits from eight to ten times the light that is given off from a flat flame burner or ordinary gas tip.

Reduction Gases.—The commercial gases formed by a reduction process are known as "water gas" since they are obtained from water through the reducing action of carbon. The nature of the products formed is again dependent upon

the temperature of the reaction. At very high temperatures the following reaction takes place:

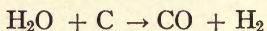

while at lower temperatures water is decomposed according to the reaction:

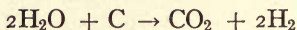

Inasmuch as temperature conditions vary continuously in the water gas generator, the products above formed may theoretically undergo a readjustment according to the equations:

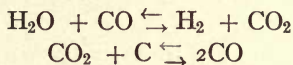

According to the conclusions of Clement and Adams,¹ the direction in which these reactions occur practically is from left to right. The same authors (*l. c.*, p. 44) have shown that at comparatively low temperatures (245–330° C.) mixtures of carbon monoxide and water vapor, and of water vapor and carbon, in the presence of finely divided nickel, will yield methane, which is a frequent but minor constituent of water gas and is no doubt formed at certain temperatures in the absence of a catalyzer.

The process of water gas manufacture takes place in a generator, carbureter and superheater. The generator consists of a large vertical furnace containing coke heated to incandescence by a current of air, the gases thus produced being burned in the superheater below described. The air is then shut off and steam is blown through the hot coke until the fall in temperature no longer permits of the decomposition of the steam by the carbon. The process is therefore intermittent, air and steam being blown through the coke alternately and the gases from the decomposition of water col-

¹ Bulletin 7, U. S. Bureau of Mines, p. 51 (1911).

lected. The gas thus obtained is next sprayed with petroleum oils, which are quickly vaporized and become mixed with the water gas. This mixture next passes into the superheater, a highly heated chamber of brickwork where the oil vapors are broken down ("cracked") into lower hydrocarbon compounds, which are permanent gases and constitute the "illuminant" or "enriched" portion of water gas.

The composition of water gas is given in Table 15. The high percentage of carbon monoxide has always made it objectionable for general use on account of its poisonous character and it is therefore used chiefly in admixture with coal gas, reducing the cost of manufacture and yielding a satisfactory gas for fuel purposes.

Incomplete Combustion Gases.—The manufactured gases thus far considered have utilized the heat from an external source to decompose coal for coal gas and to heat coke to the temperature necessary to reduce water for water gas. Producer gas, on the other hand, utilizes the heat of combustion from incomplete oxidation to produce a mixture of gases which may be used as fuels. In effect, the process of producer gas manufacture consists of the transformation of solid fuel into more readily combustible gaseous fuel. This transformation takes place in several stages: (1) the distillation of the volatile hydrocarbons from the freshly fired fuel at relatively low temperatures; (2) the combustion of fuel by the oxygen of the air, forming carbon dioxide (CO_2); and (3) the formation of carbon monoxide (CO) and hydrogen (H_2), the essential constituents of producer gas in accordance with the equations:

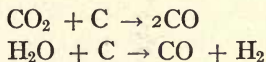

In practice producer gas is made by blowing a mixture of steam and air into a bed of burning coal or carbonaceous matter. The effect of air alone when used in excess over the

carbon is to produce carbon dioxide (CO₂) and liberate heat according to the thermo-chemical equation:

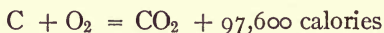

In the presence of excess carbon the product obtained is carbon monoxide (CO), the heat liberated being represented in the equation:

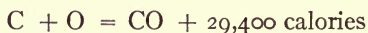

When water is reduced by carbon to hydrogen (H₂) and carbon monoxide (CO), the heat absorbed (heat of decomposition of water) is as follows:

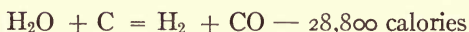

Hence by the use of a proper mixture of air and steam it is possible to generate just enough heat by direct combustion to balance the heat absorbed by the decomposition of water. The resulting gas will then be a mixture of nitrogen, carbon monoxide, and hydrogen. The function of the steam, therefore, is to reduce the heat in the producer, where it is not needed, and to transfer it to the gas for use in combustion.

Two systems of producer gas production are in use: (1) A *pressure* system, in which saturated air is forced through a bed of incandescent coal by means of a steam injector. The gas is collected and held under pressure in a gas holder. The size of the latter and the need of a boiler plant to furnish steam makes this system too bulky and complicated for small sized power plants. (2) A *suction* system, in which the inhaling action of the engine piston is used to draw the gas through the pipes from the producer. This system is used in the more common commercial forms of gas producers. It consists of a generator, steam producer or vaporizer, a cooler or purifier, and a pressure equalizer.

The generator is a cylindrical stove lined with firebrick. The interior is divided into two chambers: (1) the fire space where combustion takes place, and (2) the heating space which serves as a receiver for coal. Between the two spaces is an annular ring in which the flame develops and gases collect. A grate supports the fuel and underneath is an ash pit. Both chamber and ash pit have doors which may be closed hermetically. The generator is also provided with a charging device, with valves for the admission of air and the elimination of gases when the engine is not in operation, and with poke holes to remove slag from the walls.

The steam producer, vaporizer, or evaporator is the substitute of the steam boiler in the pressure system. The heat, however, is furnished by the generator itself. There are many kinds of devices for this purpose. The type most frequently used is that in which the hot gases after leaving the generator are passed through a series of tubes in a shell and partly immersed in water, which, becoming heated, is converted into steam and collects in the space above, where together with air it is drawn over the ash pit and through the generator. A recently patented device in use employs a spray of the water on the hot gas pipes. The water is immediately vaporized and the steam, being carried along over large heated areas, becomes superheated before entering the generator and thus withdraws no heat from the fuel.

The cooler or purifier consists of a tall vertical cylindrical vessel of sheet iron. The interior has a large number of wooden grates laid crosswise in it. Sometimes a grate is placed at the bottom and the vessel filled up with coke. The gas enters at the bottom and in rising upwards is impeded by the wooden porous partitions or pieces of coke. Water is constantly sprayed at the top and in its downward passage serves to cool and wash the ascending gas. In large plants an additional air cooled condenser is used

and sometimes a mechanical sawdust filter like those in gas works.

The regulator in the smaller plants is simply a gas chamber holding four or five times the amount of gas required for the engine cylinder. The gas receives its greatest depression due to suction at points nearest to the engine, and decreases gradually in proportion to the distance from the engine. Atmospheric pressure tends to fill the partial vacuum, and pushes the gas along toward the engine. Hence the regulator receives a fresh supply of gas under pressure and ready for the engine.

Producer gas burns with a faint blue flame. It has scarcely any odor and on account of the presence of carbon monoxide is very poisonous. It is, however (when made, as is usual, by the suction method), under less than atmospheric pressure and consequently all leakage is inward rather than outward. It may be made from any hard coal or coke. With specially designed generators, peat, wood, bituminous slack, garbage, and other combustibles may be used. One pound of coke or anthracite coal furnishes 65 to 75 cubic feet of gas, equivalent to one horse power hour in the engine. Its heating value per cubic foot is 120 to 145 B. t. u. Practically it requires 1.25 times its own volume of air for perfect combustion. A cubic foot weighs .065 to .075 pounds.

As explained later, the blast furnace is in reality a huge gas producer which works in the pressure system. Hence blast furnace gas may be classified as a true producer gas. Its composition is given in Table 15.

The efficiency of suction gas is shown in the following comparative tables taken from *Marine Engineering*.

| <i>Steam engine and boiler</i> | | <i>Gas engine and producer</i> | |
|--|-----------------|--|-----------------|
| | <i>Per cent</i> | | <i>Per cent</i> |
| Original heat energy in coal | 100 | Original energy in coal | 100 |
| Furnace losses: | | Producer losses: | |
| 1. Radiation (9.5%) . . | } 17 | 1. Scrubber (5%) | } 14 |
| 2. Incomplete combustion (0.7%) | | 2. Heating gas (2%) . . | |
| 3. Stack wastes (6.8%) | | 3. Radiation (7%) . . . | |
| Heat present in steam | 83 | Heat present in gas | 86 |
| Loss in transmission | 2 | Engine losses: | |
| Heat supplied to engine in steam | 81 | 1. Exhaust (35%) | } 66.5 |
| Engine losses: | | 2. Water jacket (27%) . . | |
| 1. Thermo dynamic (50%) | } 69 | 3. Frictional (4.5%) . . | |
| 2. Cylinder losses— (11%) | | | |
| 3. Frictional (8%) . . . | | | |
| Heat available for mechanical work | 12 | Heat available for mechanical work | 19.5 |

Gas from Decomposition of Carbides.—During recent years through the development of the electric furnace by Moissan and others, many carbides (compounds of carbon and metals) have been made. Most of these compounds react with water and yield various hydrocarbons. Moissan has shown ¹ that the metallic carbides when treated with water give various results: The carbides of lithium, sodium, potassium, calcium, strontium and barium yield acetylene (C_2H_2); the carbides of aluminum and glucinum give methane (CH_4); the carbide of manganese yields a mixture of methane (CH_4), and hydrogen

¹ *J. Am. Chem. Soc.*, 21, 647 (1899).

(H₂); while the carbides of cerium, thorium and uranium yield mixtures of acetylene (C₂H₂), methane (CH₄), ethylene (C₂H₄), and hydrogen (H₂). The only one of industrial importance is calcium carbide, from which acetylene is produced, and which is used principally for illumination but recently has been very successfully applied as a fuel in the oxy-acetylene "cutting" and welding process.

Calcium carbide is prepared on a large scale from coke and lime heated together at the high temperature of the electric furnace. It is a stable compound quite inert when kept dry and non-explosive when attacked by fire or changes of temperature. It is odorless when dry but generally gives off traces of acetylene due to the action of moisture. The ease with which it is decomposed is made use of in the generation of acetylene gas according to the reaction:

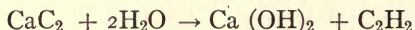

The acetylene generator is merely an automatic contrivance for admitting sufficient dry carbide from a storage hopper into water, where decomposition of the calcium carbide takes place. The generated gas is conducted to a storage tank, the pressure of the gas in the latter being utilized generally for shutting off the supply of calcium carbide and thereby stopping the generation of gas until diminished pressure again reopens the valve to admit carbide. The residue of calcium hydroxide ("hydrated lime") is removed from time to time. This is generally used for fertilizing purposes.

As an illuminant acetylene has given very satisfactory service. Its spectrum is similar to that of sunlight and its diffusive power is very great. From the standpoint of ventilation the following comparative figures based on acetylene as the standard show its desirable features:

| | <i>Carbon dioxide</i> | <i>Moisture evolved</i> | <i>Oxygen removed</i> | <i>Heat produced</i> |
|--------------------|-----------------------|-------------------------|-----------------------|----------------------|
| Acetylene. | 100 | 100 | 100 | 100 |
| Gas flame. | 480 | 1470 | 520 | 795 |
| Kerosene. | 995 | 700 | 498 | 738 |

In the arts the chief interest of acetylene is its use in cutting and welding. Oxygen under pressure in cylinders and acetylene from the generator are combined in the oxy-acetylene blowpipe and produce as the result of combustion a temperature of about 3480° C. The mixture used is one volume of acetylene and 1.7 volumes of oxygen. This method of welding is replacing the processes of riveting and brazing. No fluxes are required for iron, steel, and copper, but for brasses and bronzes boric acid is used to prevent the volatilized zinc from being deposited on the joint and interfering with the weld. The point of the flame is held about $\frac{1}{8}$ to $\frac{1}{4}$ inches from the work. The process is applicable to metal plates under $\frac{1}{4}$ inch in thickness.

Acetylene is used to some extent in forms which enable it to be transported in cylinders. When acetylene is compressed to a volume which exerts a pressure of two atmospheres to the square inch it decomposes or dissociates into its elements. Such decomposition is similar in its effects to an explosive reaction and prohibits the use of acetylene in a manner analogous to that employed in Pintsch and Blau gas distribution (q. v.). The solubility of acetylene in certain organic solvents has, however, furnished a satisfactory method for the transportation and distribution of acetylene in tanks—a method largely used for automobile headlights. The solubility of acetylene in various solvents is given in the table below and is expressed as volumes of acetylene dissolved by 100 volumes of the solvent at the temperature given and under atmospheric pressure:

| <i>Solvent</i> | <i>Temperature Degrees C.</i> | <i>Solubility of acetylene</i> |
|--------------------------|-----------------------------------|------------------------------------|
| Acetone. | 15 | 2500 |
| Acetone. | 50 | 1250 |
| Alcohol (ethyl). | 18 | 600 |
| Chloroform. | 18 | 400 |
| Paraffin oil. | 18 | 150 |
| Water. | 12 | 106 |

Since the solubility of a gas in a solvent increases with pressure, this method has given a very satisfactory means for the storage of acetylene gas, and gases in such cylinders may be used in the same way as liquefied gases. Another method ¹ of compression consists in pumping acetylene under pressure into a cylinder apparently quite full of some highly porous matter like charcoal, infusorial earth, unglazed brick, etc. This has the practical result of holding the gas under a high state of compression under conditions which keep it from exploding.

Gases from the Vaporization of Liquids.—While it is true that nearly all fuels, solid or liquid, are converted into a gas preliminary to actual combustion, yet the conventional classification is perhaps entirely appropriate in making distinctions between the state of aggregation in which a fuel exists when delivered at the point of combustion. Certain liquids are here considered because some provision in the mechanism of the combustion apparatus has been made for their vaporization and use as gases. Up to this point we have considered chiefly the heat and light effects derived from the combustion of fuels. There is, however, another combustion effect (mechanical work), which is utilized in the operation of the exploding engine, or so-called gas engine, and in connection with which certain liquids, such as gasoline and al-

¹ Leeds and Butterfield: Acetylene: Its Generation and Use, p. 266.

cohol, which find their largest application in power generation. A short description of the general type of gas engine operation will be given before discussing the fuels used in them.

The mechanism of the exploding engine consists of a cylinder and explosion chamber, valves for expelling products of combustion and for admission of fuel gases, carbureter for vaporizing the fuel, and mixing it with the air, igniting gear to furnish the electric spark and explode the mixture, a cooling jacket, and a lubrication system.

The combustion of gaseous mixtures is similar to the combustion of gunpowder. If an explosive mixture in a glass tube is ignited it is possible to follow with the eye the progress of the explosion flame along the tube. In order to be explosive, air and vapor (combustible gas) must be mixed in chemical proportions. A large excess of vapor, or of air, will render the mixture non-explosive. The limits between which the air and combustible gas may vary in percentage by volume are given in the following table:¹

| <i>Combustible gas</i> | <i>Lower explosive limit Per cent</i> | <i>Upper explosive limit Per cent</i> | <i>Range covered by explosive mixtures Per cent</i> |
|------------------------|---|---|---|
| Carbon monoxide | 16.00 | 74.95 | 58.95 |
| Hydrogen..... | 9.45 | 66.40 | 56.95 |
| Water gas..... | 12.40 | 66.75 | 54.35 |
| Acetylene..... | 3.35 | 52.30 | 48.95 |
| Coal gas..... | 7.90 | 19.10 | 11.20 |
| Methane..... | 6.10 | 12.80 | 6.70 |
| Gasoline..... | 2.40 | 4.90 | 2.50 |

The temperature of ignition has much to do with the explosibility of gaseous mixtures as has also the pressure (concentration) of the mixture. By changing these factors

¹ Eitner: *J. Soc. Chem. Ind.*, 21, 395 (1902).

mixtures which will not explode at low temperatures or low compression can thus be utilized. Of the vaporized liquids usually employed in the gas engine, the heavier petroleum distillates (kerosene and "engine distillate") have a low temperature of ignition, while that of gasoline is higher, and of alcohol mixtures considerably higher. The same order applies to the rate of propagation (velocity with which the flame cap travels) of the explosive flame. The latter may transmit itself by either uniformly heating successive layers and igniting them or by wave motion.

Gasoline is a fuel much used in the exploding engine. It is a petroleum distillate of low boiling point and specific gravity and represents a mixture of hydrocarbons of the character of pentane (C_5H_{12}) and hexane (C_6H_{14}). A specimen examined by the usual method of fractional distillation used in petroleum oil analysis ¹ gave the following results:

TABLE 17.—Distillation Test for Gasoline, 300 cc. distilled

| Number of fraction | Temperature of distillation ° C. | Volume | | Specific gravity at 15° C. |
|--------------------|-------------------------------------|--------|------|----------------------------|
| | | cc. | % | |
| 1 | 40-70 | 40.5 | 13.5 | 0.670 |
| 2 | 70-80 | 47.5 | 15.8 | 0.690 |
| 3 | 80-90 | 60.0 | 20.0 | 0.706 |
| 4 | 90-100 | 47.5 | 15.8 | 0.722 |
| 5 | 100-110 | 42.5 | 14.2 | 0.733 |
| 6 | 110-120 | 29.5 | 9.9 | 0.741 |
| 7 | residue at 120° C. | | | 0.755 |

Other petroleum products are sometimes employed in the gas engine, such as benzine, "engine distillate," and kerosene, all of which are of higher specific gravity and boiling point than gasoline.

Alcohol is a definite chemical compound (C_2H_6O) and is made generally by fermentation of sugars; either sugar house

¹ Sherman's Organic Analysis, p. 250.

products or sugars obtained by hydrolysis of starch or of cellulose may be used. The alcohol of commerce is a solution of alcohol in water and is described either in terms of "per cent" or "proof." The former term refers to the percentage of alcohol by volume contained in a mixture of alcohol and water, while the term "proof" refers to an empirical scale. A 50 per cent alcohol mixture represents a 100° proof alcohol, while a perfectly pure or absolute alcohol is rated as 200° proof.

The density of alcohol is of course dependent upon the amount of water present and varies with the temperature. By determining its density therefore and referring to the Morley¹ conversion tables, the percentage of alcohol contained in the mixture may be readily ascertained. The ordinary denatured alcohol of commerce contains about 90 per cent alcohol.

In Germany the alcohol engine has been extensively used for farm purposes and has given uniform satisfaction both as to cost of fuel and capacity for work. An investigation² made by Prof. C. E. Lucke and S. M. Woodward sets forth among others the following conclusions regarding the use of alcohol as fuel for engines: (1) Any engine on the American market to-day operating with gasoline or kerosene can operate with alcohol fuel without any structural change. (2) A small engine requires 1.8 times as much alcohol as gasoline per horse power hour. (3) Carburetors designed for gasoline do not always vaporize all the alcohol supplied. If certain alterations are made by which the compression is increased and all the alcohol vaporized, the power of the engine is increased 20 per cent over gasoline or kerosene as fuel. (4) Storage of alcohol and its use in engine is much less dangerous than that of gasoline. The exhaust from an alcohol engine is less offensive than when gasoline is used, though some odor,

¹ *J. Amer. Chem. Soc.*, 26, 1085 (1904).

² Farmers' Bulletin No. 277, U. S. Dept. of Agriculture (1907).

due to lubricating oil and imperfect combustion, is likely to be present.

The nature of the chemical reaction which takes place within the cylinder of the exploding engine is varied by many factors, such as ratio of oxygen to combustible gas, presence of water vapor in air, compression, and temperature. Under ideal conditions the complete combustion of gasoline and alcohol may be represented by the following reactions:

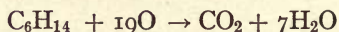

(Gasoline)

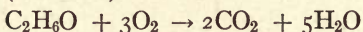

(Alcohol)

For fuel purposes alcohol is "denatured" so as to unfit it for use in beverages and medicines. The denaturing agent is usually wood alcohol and benzine or kerosene. The regular formula for denaturing is as follows: To 100 parts by volume of ethyl alcohol (not less than 90 per cent strength) add 10 parts of approved methyl (wood) alcohol (about 88 per cent strength) and 0.5 part of approved benzine (or kerosene). Such alcohol is classed as "completely denatured" and becomes a regular article of commerce. Its fuel value is about 6000 calories per gram or about 11,000 B. t. u. per pound whereas that of gasoline or benzine is about 20,000 B. t. u. per pound. This corresponds also with the experimental result of Lucke and Woodward who found that the development of a given horse power required about 1.8 times as much alcohol as gasoline.

Air Gas.—The vapor of liquids such as gasoline and naphtha is sometimes utilized for heating and lighting effects in the form of the so-called air gas, or carbureted air. The process in general requires an apparatus for bubbling air through gasoline or passing it over a succession of trays or shelves containing gasoline, thus producing a mixture of air and gasoline vapor in the proportions of about 98 per cent

air and 2 per cent gasoline. In the "Autogene"¹ air gas system, air is drawn through the generator by a pump which is operated by a weight driven, electric, or water motor or by a hot air motor supplied with gas from the system. Gas is generated only as needed for immediate consumption. The outfit is capable of producing 1200 cubic feet of gas for each gallon of gasoline used.

RELATIVE VALUES AND COSTS OF FUELS

In summarizing the value of particular fuel for heat and power generation, attention must be given to specific conditions. Some of these are: local variations in prices of fuels; adaptability to some particular work, such as immediate starting and intermittent character; minimum amount of attention to the generating plant; employment of unskilled labor for maintenance of plant, and the specific properties of fuels with reference to their effects. For such reasons fuels are in use which cost from 48 to 50 times as much as the cheapest, as may be noted in Table XIV taken from "Motor," showing the number of British thermal units which may be produced for one cent:

TABLE 18.—Relative Cost of Fuels. British Thermal Units for One Cent

| | |
|--|--------|
| Acetylene, from carbide at 10 cents per pound..... | 600 |
| Denatured alcohol, at 40 cents per gallon..... | 2,000 |
| Water gas, at \$1 per 1000 cubic feet. | 3,000 |
| Air gas (from gasoline, at 25 cents per gallon)..... | 6,000 |
| Coal gas, at \$1 per 1000 cubic feet. | 6,500 |
| Gasoline, at 20 cents per gallon. | 7,500 |
| Kerosene, at 15 cents per gallon. | 10,000 |
| Natural gas, at 50 cents per 1000 cubic feet | 18,000 |
| Charcoal, at 10 cents per bushel (15 pounds). | 20,000 |
| Petroleum at 5 cents per gallon. | 30,000 |

¹ Described in Consular Report of U. W. Burke, Fremantle, Western Australia.

TABLE 18.—*Continued*

| | |
|--|--------|
| Producer gas, from anthracite, \$7 per ton. | 30,000 |
| Producer gas from coke, \$5 per ton. | 36,000 |
| Anthracite, at \$7 per ton. | 46,000 |
| Producer gas, from soft coal, at \$3 per ton. | 50,000 |
| Coke, at \$5 per ton. | 54,000 |
| Mond producer gas, from soft coal, at \$3 per ton. | 65,000 |
| Soft coal, at \$3 per ton. | 80,000 |

REFERENCES

I

- ALLEN: Specifications for the Purchase of Fuel Oil. U. S. Bureau of Mines, Technical Paper No. 3.
- BOOTH: Liquid Fuel and its Apparatus.
- BUTTERFIELD: The Chemistry of Gas Manufacture.
- CASTE: The Calorific Power of Gas.
- DOWSON AND LARTER: Producer Gas.
- FERNALD: Producer Gas Power Plant Development in Europe. Bull. 4, Bureau of Mines, U. S. Dept. of Interior.
- GILL: Gas and Fuel Analysis for Engineers.
- GULDNER: The Design and Construction of Internal Combustion Engines.
- HEMPEL: Methods of Gas Analysis.
- HERRICK: Denatured or Industrial Alcohol.
- LATA: American Producer Gas Practice and Industrial Gas Engineering.
- LEEDS: Acetylene, the Principles of its Generation and Use.
- ROBSON: Power Gas Producers.
- ROGERS AND AUBERT: Industrial Chemistry.
- SHERMAN: Methods of Organic Analysis.
- STONE: Practical Testing of Gas and Gas Meters.
- STRONG AND STONE: Comparative Fuel Values of Gasoline and Denatured Alcohol. Bull. 43, Bureau of Mines, U. S. Dept. of Interior.
- WYER: A Treatise on Producer Gas and Gas Producers.

II

- ADAMS: Cheap Gas and Fuel. *Mines and Minerals*, 22, 508 (1902).
- DOUGLAS: Wood Gas for Power Purposes. *Eng.*, 80, 299 (1905).
- REINHARDT: Purification of Gas for Gas Engines. *Eng. Mining J.*, 82, 776 (1906).

- BIGELOW: Denatured Alcohol. *Pop. Sci. Monthly*, **70**, 243 (1907).
- HARVEY: Gas Producers for Bituminous Coal. *Cassier*, **33**, 199 (1907).
- ROWAN: The Suction Gas Producer. *Cassier*, **33**, 174 (1907).
- TAITE: Producer Gas Composition. *Cassier*, **33**, 142 (1907).
- THOMSON: Alcohol Engine as a Future Power. *Electr. World*, **49**, 20 (1907).
- U. S. Internal Revenue Regulations, No. 30, Revised. Concerning Denatured Alcohol, Central Denaturing Bonded Warehouses, and Industrial Distilleries.
- BASKERVILLE AND HAMOR: Oil Shales of America. *J. Ind. Eng. Chem.*, **1**, 507 (1909).
- STONE: Notes on Anthracite Producer Practice. *J. Ind. Eng. Chem.*, **1**, 11 (1909).
- DANNE: Natural Gas and its Production. *Met. Chem. Eng.*, **8**, 412 (1910).
- FERNALD: Producer Gas Plants in the United States. *Eng.*, **90**, 898 (1910).
- MOORHEAD: Determination of Calorific Power and the Operating Conditions from Analyses of Flue Gases. *Am. Gas Light J.*, **93**, 929 (1910).
- ALLEN: Specifications for the Purchase of Fuel Oil. *J. Ind. Eng. Chem.*, **3**, 730 (1911).
- BARROWS: Natural Gas, Production and Utilization. *Trans. Ill. Eng. Soc.*, **7**, 105 (1911).
- BUCK: Use of Blast Furnace Gas. *Iron Age*, **87**, 902 (1911).
- CLARKE: Manufacture of Crude Oil Gas. *Prog. Age*, **29**, 189 (1911).
- FURNALD AND SMITH: Résumé of Producer-Gas Investigations. U. S. Bureau of Mines, Bull. 13 (1911).
- STRONG: Comparison of Gasolene and Alcohol Tests on Internal Combustion Engines. U. S. Bureau of Mines, Bull. 32 (1911).
- SCOTT: Coke Oven Gas as an Open Hearth Fuel. *Chem. Eng.*, **14**, 411 (1911).
- SCOTT: Estimation of Moisture in Fuel Oil. *Chem. Tec. Ztg.*, **6**, 29 (1911). *Chem. Abs.*, **5**, 2425 (1911).
- Gas Calorimetry. *Chem. Eng.*, **15**, 12 (1912).
- AMSLER: Recent Improvements in Producer Gas Appliances. *Industr. World*, **46**, 342 (1912).
- BIRD: Recent Development in the Manufacture of Water Gas. *Prog. Age*, **30**, 244 (1912).
- DAY: The Production of Petroleum in 1911. U. S. Geol. Survey (1912).
- FELD: A Centrifugal Gas Washer. *Met. Chem. Eng.*, **10**, 436 (1912).
- FURNALD: The Status of the Gas Producer and of the Internal-Combustion Engine in the Utilization of Fuels. U. S. Bureau of Mines, Technical Paper 9 (1912).

SNELLING: Liquefied Natural Gas. *Prog. Age*, **30**, 526 (1912).

JAMES: Acetylene Solvents. *J. Ind. Eng. Chem.*, **5**, 115 (1913).

American Gas Institute, Report on Calorimeters. *Gas World*, **58**, 154 (1913).

FERNALD: The Commercial Trend of the Producer-gas Power Plant in the United States. U. S. Bureau of Mines, Bull. 55 (1913).

PATTERSON: The Chemical Examination of Liquid Fuels. *J. Soc. Chem. Ind.*, **32**, 218 (1913).

CHAPTER VII

PETROLEUM AND LUBRICATING OILS

THE industrial importance of petroleum becomes evident when it is noticed that the annual production of petroleum in the United States is approximately two hundred million barrels (of 42 gallons each). From the petroleum industry various fuel products are obtained which have been discussed in the previous chapter. On account of its technical uses, especially in the preparation of lubricants, it is of interest to discuss more fully the composition and properties of petroleum and the methods whereby the more important petroleum products are obtained. The general properties of other oils and substances used in lubrication will also be described in this chapter.

PETROLEUM

The world's petroleum supply is not limited to any one locality and considerable variation in composition is found in the petroleums from the different fields. Three general classes or types of petroleum are: (1) the paraffin (often called Pennsylvania petroleum), (2) the asphaltic (known as California petroleum), and (3) the olefine (Russian) petroleum. Of these three kinds the first is the source of most of the refined petroleum products of America, the second constitutes the principal source of fuel oil and of petroleum asphalt, while the third, consisting of about 25 per cent of the world's production, is used both for fuel and for refining purposes.

The **Petroleum Fields of the United States** comprise five in number and are named according to their geographic location (1) the Appalachian, (2) the Lima-Indiana-Illinois, (3) the Mid-Continent, (4) the Gulf, and (5) the California field.

The Appalachian field extends along the western slope of the Allegheny Mountains from New York to Tennessee. The oil and gas are obtained from porous sandstones and conglomerates which are imbedded in and underlain by great masses of shale. The oil is known as Pennsylvania petroleum, belongs to the paraffin class, and yields on distillation a variety of light oils of great value. In the crude state it is usually dark brown with a greenish tinge, shows a specific gravity of 0.86 to 0.78 (32° to 49° Baumé),¹ and contains very little sulphur (usually 0.05 to 0.08 per cent).

The Lima-Indiana and Illinois field yields an oil containing more sulphur, usually 0.25 to 0.5 per cent or more and which is somewhat inferior to the Pennsylvania petroleum. This oil is obtained from the Trenton limestone beds. This is a dolomitic limestone which is sufficiently porous to allow gas, oil and water to flow through it. The oil from this field is a brownish black liquid with a specific gravity of about 0.85, or 35° Bé. The presence of sulphur compounds gives it a disagreeable odor.

The Mid-Continent field is located in Kansas and Oklahoma. The shales of this region contain sandstone beds which form the reservoir from which the oil and gas are obtained. The oils from this field are dark in color, vary from 18° to 40° Bé, and carry some sulphur.

In the Gulf field, which comprises portions of Louisiana and Texas, the oil comes from dolomitic limestone and from sand and sandstone reservoirs. It has a density of 18° to

¹ The relation between specific gravity and degrees Baumé for liquids lighter than water is as follows: Specific gravity = $\frac{140}{130 + B^{\circ}}$

28° Bé and on distillation yields a residue which contains a low percentage of paraffin and is somewhat asphaltic in character (i. e., a mixture of paraffin and asphalt). In 1909 the Gulf field produced about 6 per cent of the total oil output of the United States.

The oil of the California field is obtained from sandstone or fine gravel. Each of the various oil fields in California has a distinctive geological history and the oils vary greatly in character. In general the California oils are of an asphaltic nature.

The Chemical Composition of Petroleum varies with the kind. In Pennsylvania petroleum some 26 members of the paraffin series (C_nH_{2n+2}) of hydrocarbons have been isolated, together with some members of the olefine (C_nH_{2n}) series, the latter occurring in much smaller quantities than the former. In the Russian and California petroleum these elofines are not "open chain" compounds of an unsaturated type, but are cyclic and belong to the polymethylene¹ or naphthene series. In the Texas petroleum members of the acetylene (C_nH_{2n-2}) series have been found, while most petroleum contains members of the "aromatic" or benzene (C_nH_{2n-6}) series. Nitrogen is a constituent of nearly all petroleum, Mabery having isolated compounds resembling organic bases with empirical formulas $C_{12}H_{17}N$ to $C_{17}H_{21}N$. The same investigator found ten sulphur compounds in Ohio petroleum which range from methyl sulphide $(CH_3)_2S$ to hexyl sulphide, $C_{12}H_{26}S$.

Origin of Petroleum.—The theories thus far advanced to explain the origin of petroleum may be divided into two categories, the inorganic and the organic. The former is the outcome of attempts made to prepare petroleum artificially.

¹ For an explanation of these terms the student is referred to standard text books on Organic Chemistry and for an important summary of our knowledge relative to the composition of American petroleum reference is made to C. F. Mabery, *J. Am. Chem. Soc.*, 28, 415 (1906).

A brief description of these researches may be of especial interest in this connection.

It is well known that the odor present in the generation of hydrogen by the interaction of iron and an acid is due to carbon compounds formed from the decomposition of metallic carbides which are present as impurities in the iron. As early as 1864 Hahn showed the presence of olefines from C_2H_4 to C_7H_{14} , while in the hydrogen evolved from *spiegel eisen*, still higher hydrocarbons up to $C_{16}H_{32}$ were found. The experimental work of Moissan later demonstrated that the decomposition of the metallic carbides produced mixtures of hydrocarbons, such as acetylene, methane, ethylene and others. Although acetylene itself is not a constituent of petroleum, it has been shown by Sabatier and Senderens¹ that when hydrogen and acetylene are heated to $200^\circ C.$ in the presence of finely divided metallic nickel, a mixture of paraffins is formed which resembles Pennsylvania petroleum; while acetylene alone, similarly heated, yields a mixture closely analogous to Russian petroleum. It thus appears that synthetic petroleum is not impossible and this leads to the carbide theory for explaining the origin of petroleum.

The carbide theory was first suggested by Berthelot.² The theory of Berthelot was supported by Mendeleef³ and Moissan.⁴

On the organic side attention has been chiefly directed to the preparation of petroleum-like oils by processes of destructive distillation. In 1865 Warren and Storer distilled a lime soap from menhaden (fish) oil and obtained a mixture of hydrocarbons from which they isolated the paraffins C_5H_{12}

¹ *Compt. Rend.*, **134**, 1185 (1903).

² *Ann. Chim. Phys.*, 4th ser., **9**, 481 (1866).

³ *J. Chem. Soc.*, **32**, 283 (1877). Also Mendeleef's Principles of Chemistry, English translation, Vol. 1, 364-66 (1891).

⁴ *Compt. Rend.*, **122**, 1462 (1896).

to C_8H_{18} , the olefines C_5H_{10} to $C_{12}H_{24}$, together with benzene, toluene, and other members of the aromatic series. Later Engler's¹ researches led to the announcement of the organic theory to account for the origin of petroleum.

According to the organic theory, petroleum is derived from animal remains by a putrefactive process in which the nitrogen is removed. This leaves the fats to be altered by heat and pressure into hydrocarbon oils, reactions which may be carried out in the laboratory by heating pure oleic acid to $330^\circ C.$ for several hours in a sealed tube.² The presence of fossils in the oil strata, the sedimentary type of the oil formations, the presence of saline residues, are all cited as evidence of the origin of petroleum from animal sources. The organic theory, however, does not confine itself to animal sources alone, but brings forward many data that show the possible formation of petroleum from vegetable matter as well. The remains of cellular marine plants are abundant in the oil formations of the eastern United States. It has been suggested that great masses of fucus, like those of the Sargasso Sea might sink to the bottom of the ocean and there decomposing under pressure, yield petroleum. Some importance is also attached to the fact that the saline waters associated with California petroleum are unusually rich in iodine, a product chiefly derived from seaweeds.

From the observations advanced and from many others not cited it is believed by many that petroleum may have been formed by all of these processes. Accordingly, volcanic action, forming carbides, may have produced some petroleum deposits. Oils high in nitrogen, such as the California oils, may have been formed from animal sources, while a paraffin oil (like the Pennsylvania oil) may have had vegetation for its source.

¹ *Ber. deut. chem. Gesell.*, 21, 1816 (1888).

² See the experiments of J. Marcusson: *Chem. Zeit.*, 30, 789 (1906).

INDUSTRIAL PRODUCTS FROM PETROLEUM

The properties of petroleum are extremely variable; some oils are suitable for illuminating purposes in the crude form, though that is unusual; others may be used for lubricating purposes; while others are of a heavy viscous character and are excellent for road binding purposes. More generally, however, a crude petroleum represents a mixture of hydrocarbon oils from which oils suitable for various purposes may be obtained by distillation and refining processes. Remsen¹ enumerates these industrial products and their relative quantities, so far as American petroleum is concerned, as follows:

| | <i>Per cent of total</i> | <i>Amount in 1909, barrels</i> |
|------------------------------|------------------------------|------------------------------------|
| 1. Kerosene. | 20.5 | 15,000,000 |
| 2. Lubricating oils. | 10.0 | 7,500,000 |
| 3. Naphthas. | 15.0 | 11,250,000 |
| 4. Gas oil. | 30.0 | 22,000,000 |
| 5. Paraffin wax. | 1.5 | 1,125,000 |
| 6. Roofing pitch. | 2.5 | 1,875,000 |
| 7. Paving pitch. | 2.0 | 1,500,000 |
| 8. Fuel oil. | 14.0 | 10,500,000 |
| 9. Coke. | 3.0 | 300,000 (tons) |

In this table kerosene is the general name for petroleum oils used in lamps, stoves, etc.; lubricating oils also include solid greases, etc.; naphthas refer to light oils boiling below 175° C.; gas oil is used for enriching water gas (q. v.); paraffin wax is the solid mixture used for candles, etc.; the pitches are heavy products recovered from chemical refining that are made from what is commonly known as "oil sludge"; coke is the residue from distillation, and fuel oil consists of oils not suitable for refining or portions of the distillate.

¹ *J. Soc. Chem. Ind.*, 29, 859 (1910).

REFINING OF PETROLEUM

In considering the refining processes it will be advantageous to discuss, first, the methods applicable to paraffin petroleum, and second, those employed in the refining of asphaltic petroleums.

The apparatus used consists of stills of cylindrical shape, made of steel. The still is usually built in the form of a horizontal cylinder set in brickwork but each still is fitted with a dome, an outlet pipe, and other connections for introducing the oil, sampling it, and introducing steam.

When a paraffin petroleum is distilled, five principal fractions are obtained, (1) the naphthas, (2) the illuminating oils, (3) the lubricating oils, (4) the paraffin, and (5) the coke residue. In carrying on this distillation the crude oil, after settling in the storage tank to remove mud and water, is charged into the still and heated by means of fire heat from the furnace underneath the still and by steam coils within the still. The steam coils are often perforated to admit the steam after it has been heated to the temperature of the oil by passage through a sufficient length of pipe immersed in the hot oil. The action of steam superheated in this manner is largely mechanical. It assists in carrying off the vapors, keeps the contents of the still agitated, and prevents local overheating, or "burning" the oil. The process is controlled chiefly by hydrometer or density measurements, the distillate being collected in fractions of different densities and boiling points according to the products for which the oil is being worked. As the heating continues, heavier oils are distilled over, and at about 300° C., when the illuminating oil distillate is complete, the residue in the still may be removed to a smaller still and subjected to distillation with superheated steam, which yields a mixture of oils used for lubrication. The paraffin is next recovered from the residue as well as from the heavier lubricating oils by cooling or "chilling" the

liquids and mechanically removing the paraffin in its solid form. For a fuller description of the refining of petroleum (particularly of the "paraffin base" type) see Gray's article, *The Petroleum Industry*, in Rogers and Aubert's *Industrial Chemistry*.

In the refining of California petroleum two distinct classes of oils are to be considered: (1) light oils suitable for refining into the usual products, as mentioned above, and (2) heavy oils which are unsuitable for refining into a variety of products, but which chiefly are useful for asphalt production.

In light oil refining the following products are obtained in the case of a typical crude oil ¹ from the Coalinga field.

| | <i>Gravity</i> | <i>Per cent</i> |
|----------------------------|----------------|-----------------|
| Gasoline. | 81° Bé | 0.15 |
| Gasoline. | 74 " | 0.46 |
| Benzine | 63 " | 0.94 |
| Engine distillate. | 54 " | 2.34 |
| Kerosene. | 42 " | 11.47 |
| Stove oil. | 33 " | 1.88 |
| Gas oil. | 31 " | 32.24 |
| Gas oil. | 28 " | 3.43 |
| Fuel distillate. | 26 " | 5.06 |
| Lubricant. | 22 " | 17.83 |
| Lubricant. | 17 " | 4.84 |
| Lubricant. | 15 " | 1.66 |
| Asphalt. | Grade "B" | 13.34 |
| Losses. | | 4.36 |

The commercial gasoline made from California oils is usually from 66° to 68° Bé which corresponds in boiling range and speed of evaporation to a 72° Bé Pennsylvania gasoline. Benzine is a slightly heavier gasoline having a density of about 62° Bé. Engine distillate ranges from 56° to 40° Bé in

¹ Bulletin No. 32, California State Mining Bureau (1904).

gravity and grades from a heavy gasoline into a kerosene. The kerosene from California petroleum is not of as high a quality as that of Pennsylvania petroleum, its flame being less white and there being more tendency to smoke and to crust the wick. Kerosene oil has a gravity of 42° to 40° Bé. A slightly heavier oil, 35° to 32° Bé, is known as stove oil and is used as a fuel in stoves which are equipped with suitable burners. Gas oil, 30° to 28° Bé, is a distillate formerly used for enriching water gas, but now largely superseded by the introduction of processes using crude oil. The fuel distillate is generally a mixture of otherwise unsalable oils and ranges in gravity from 24° to 28° Bé. The lubricating oils of California seem somewhat uncertain as to quality, although no objection seems to be urged against them, except that they have a low viscosity at high temperatures.

The heavier oils of California are distilled for the production of asphalt. The stills for this purpose are large, of about 600 barrels capacity, and are provided with steam coils. The temperature of distillation is maintained at about 600° F., at which point it is believed that asphalt is produced from the heavier hydrocarbons of the crude oil. The products removed below 600° F. constitute about 55 to 60 per cent and consist largely of engine distillate and gasoline.

LUBRICATING OILS

Lubrication of machinery has for its object the elimination, as far as possible, of friction between solids. When oil is added to a bearing and the shafting set in motion, the oil on the latter moves with it while that on the bearing moves very slowly. Hence the friction is between two layers of oil and may be called fluid friction. In order to substitute fluid for solid friction, the oil introduced between the solids must have sufficient viscosity and adhesive power to adhere to the surfaces and stay in place but any additional viscosity means an additional consumption of power.

For the purpose of finding an expression to represent the friction developed between two solids we may regard W as the weight of a body which slides on a horizontal plane under the impulse of a force, F , which pushes it uniformly over the surface. The coefficient of friction, f , then becomes F/W . This is measured by various experimental devices which are used in the testing of lubricants.¹ In solid friction f is dependent upon the nature of the surfaces and proportional to the force with which the two surfaces are pressed together, but it is independent of the area of the contact between the surfaces and of the velocity of rubbing.

In fluid friction, on the other hand, the coefficient of friction is proportional to the area of the rubbing surface and to the velocity of the surface (usually directly proportional at low speeds and to the square of the velocity at high speed) and to the density and viscosity of the liquid, but, in perfect lubrication, it is independent of the pressure between the masses and of the nature of the solid surfaces against which the fluids may flow. In practice, however, complete fluid friction is seldom obtained and the coefficient of friction is therefore compounded of the friction of solids and of fluids.

From the relation which density and viscosity bear to friction it is apparent that these two properties have much to do with the value of an oil for lubrication, though other conditions must be considered. For example, since an oil of unnecessarily high viscosity will produce unnecessary fluid friction, it is not as satisfactory as an oil of lower viscosity for the given conditions. If, however, an oil has been found satisfactory for certain uses and its density and viscosity determined under standard conditions,² then it is probable that another oil of similar kind and composition with the same

¹ The friction machines of Thurston, Carpenter, or the Galena machine, may be employed. See descriptions in Allen's *Commercial Organic Analysis*, pp. 171 and 182; and *J. Eng. Ind. Chem.*, 2, 171 (1910).

² Sherman: *Organic Analysis*, p. 226.

viscosity and specific gravity will give similar service under the same conditions of temperature and pressure.

The requisites of a lubricant in addition to having sufficient "body" or viscosity to prevent solid friction are: (1) maximum fluidity consistent with the body required, (2) maximum conduction of heat, (3) high flash and burning points, (4) freedom from corrosive acids, (5) absence of oxidation and "gumming," and (6) freedom from grit.

The lubricants in commercial use include water, oils, greases, and solids.¹ Of these, water is perhaps of least importance, since in itself it possesses no oiliness whatever, but is nevertheless used under certain conditions in cylinders where it imparts to the metallic surfaces a smooth condition which serves materially to reduce the friction.

The oils used in lubrication include a large variety of "light spindle," "heavy engine," and "cylinder" oils composed of unmixed petroleum products, of compounded oils (mixtures of petroleum and animal or vegetable oils), and, to a lesser degree, of animal and vegetable oils used without admixture of petroleum products.

Mineral Oils obtained from the distillation of shale or of crude petroleum are largely used as lubricants because of their cheapness and stability. The methods of refining employed in the preparation of the petroleum lubricating oils have much to do with the quality of the products. Some of the best lubricating oils are made by subjecting suitable crude petroleum to a "reducing" process by which the flash point of the oil is raised and its specific gravity increased. This is done by pouring the initial product upon water in shallow troughs and exposing it to the action of the sun and air, or else by heating it in shallow troughs to 110° F. by means of steam pipes.

When the "lubricating oil fraction" of the distillation of petroleum is used, it often happens that free alkali, sodium

¹ Mabery: *J. Ind. Eng. Chem.*, 2, 115 (1910).

sulphate, or the sodium salts of organic acids are present in the oil. These are the result of improper refining and any of them may be the cause of injury to metallic surfaces. According to Mabery¹ the best spindle oils, such as are used in automobile service, contain a minute trace of alkali. The petroleum oils are now prepared for such a great variety of uses that no definite limits of composition and properties within the general requisite above specified can be set, but the analyses given in Table 19 may serve to represent the usual properties:²

TABLE 19.—Physical Properties of Lubricating Oils

| | Lubricating oil | Oil used in circulating system | Summer car oil | Winter car oil | Cylinder oil | Cylinder oil |
|------------------------------|-----------------|--------------------------------|----------------|----------------|-------------------|------------------|
| Flash point, °F. | 365 | 410 | 350 | 210 | 525 | 550 |
| Burning point, °F. | 440 | 470 | 425 | 260 | 600 | 600 |
| Density at 60° F., °Baumé | 30 | 23 | 26 | 27 | | |
| Color. | Dark | Red | | | { Light Filter | Dark |
| Cold Test, °F. | Zero | +5 | +20 | —5 | +55 | +32 |
| Viscosity (P. R. R. pipette) | | | | | | |
| at 52° C., 125° F. | 98 | 85 | | | 126 ³ | 145 ³ |
| at 38° C., 100° F. | 160 | 143 | | | | |
| at 32° C., 90° F. | 205 | 188 | | | | |
| at 27° C., 80° F. | 271 | 253 | | | | |

Fatty Oils.—The glycerides or glyceryl esters of fatty acids form a definite group of chemical compounds all of which are fats. As a matter of custom and convenience those fats which are liquid at ordinary temperatures are called *fatty oils*. Nat-

¹ *Loc. cit.*² *J. Ind. Eng. Chem.*, 2, 179 (1910).³ By Saybolt Viscosimeter at 212° C.

ural and commercial fats and fatty oils always consist of mixtures of glycerides. When such a mixture of glycerides is hydrolyzed (i. e., split with introduction of the elements of water) it yields glycerol (glycerin) and a mixture of fatty acids such as oleic acid, stearic acid, etc. When fatty oils used as lubricants are exposed to the action of steam (e. g., in steam cylinder lubrication) this hydrolysis may occur to some extent and the liberated fatty acid may corrode the metal surface. For this reason mineral oils are now more largely, and fatty oils less largely, used for lubrication than formerly.

Fatty oils have, however, the advantage over mineral oils that their viscosities do not decrease so rapidly on warming; in other words, a fatty oil "holds its viscosity" better when it becomes warmed by use than does mineral oil, and for this reason fatty oils are still considerably used as lubricants either alone or (more often) in admixture with petroleum products as "compounded oils."

Table 20 shows some significant physical properties of a number of the fatty oils chiefly used as lubricants.

TABLE 20.—Physical Properties of Fatty Oils Used for Lubrication
(Compiled from Various Sources)

| | <i>Lard Oil</i> | <i>Neats- foot</i> | <i>Sperm</i> | <i>Olive</i> | <i>Rape</i> | <i>Cotton- seed</i> |
|-------------------------------------|---------------------|------------------------|--------------|--------------|-------------|-------------------------|
| Flash point, °F. | 560 | 450 | 480 | 450 | 560 | 570 |
| Burning point, °F. | 640 | 530 | 570 | 540 | 640 | 640 |
| Density °Baumé at 60° F. | 22.5 | 23. | 29. | 22.5 | 23.5 | 22 |
| Cold test °F. about | +25 | +40 | +35 | +30 | +20 | +30 |
| Viscosity, Stillman ¹ at | | | | | | |
| at 20° C., 68° F. | 110 | 120 | 66 | 126 | 151 | 102 |
| at 50° C., 122° F. | 58 | 56 | 44 | 48 | 52 | 52 |
| at 100° C., 212° F. | 38 | 36 | 32 | 36 | 40 | 34 |
| at 150° C., 302° F. | 32 | 32 | 30 | 32 | 32 | 30 |

¹ Stillman: Engineering Chemistry, 2d Ed., p. 368, where an extended table showing viscosities of many oils at different temperatures will be found.

Lard oil which is obtained by subjecting lard to high pressure at any desired temperature is much used as a constituent of lubricating oils and also to cool the cutting edge of a metal-working tool and to produce a smooth surface finish on the product. For use as a lubricant lard oil is usually pressed at such a temperature that it can be cooled below the freezing point of water before beginning to solidify. The solidifying point or "cold test" may of course be varied to a considerable extent by adjusting the temperature at which the oil is pressed from the lard. High grade lard oil should contain not over one per cent of free acid, chiefly oleic acid, which is too weak to have any marked corrosive action. In low grades the acidity is often much higher.

Neatsfoot oil, obtained by "rendering" the feet of cattle is similar to lard oil and like it is used for compounding with petroleum products.

Sperm oil (which chemically is not a fatty oil but a liquid wax) is obtained from the head cavities and blubber of the sperm whale (*Physeter macrocephalus*), the corresponding oil from the doegling or bottlenose whale (*Hyperoodon rostratum*) being known as "Arctic sperm oil." A petroleum distillate of similar physical properties to sperm oil is sold under the name of "mineral sperm oil" and sometimes used as an adulterant of true sperm oil. Sperm oil is spoken of as a "thin" oil due to the fact that at ordinary temperatures it is much less viscous than the ordinary fatty oils. On heating, however, sperm oil "holds its viscosity" better than the fatty oils and at 150° C. or about 300° F. it has nearly the same viscosity as lard oil. Being limpid and free from tendency to gum, sperm oil is especially well adapted to the lubrication of light machinery; for example, it has been largely used for lubricating the spindles of textile mills.

Olive oil is prepared from the fruit of the olive tree, which contains from 40 to 60 per cent oil. The finest grades are made by hand pressing. The cheaper grades are made by

mechanical pressure, heat, and the use of a solvent. The latter grades are sometimes used as a lubricant. It varies in color from clear yellow to greenish brown. It is rather easily decomposed, yielding fatty acids, and is too expensive for general use.

Rapeseed oil, also known as *colza oil*, is obtained from the seeds of the rape plants by pressure, the yield being from 30 to 45 per cent of the weight of the seed. The crude oil is "brown rape oil," which contains considerable moisture, mucilage and coloring matter. It is refined by treatment first with sulphuric acid and then with caustic soda. In the refined condition it has a pale yellow color, a characteristic odor, and thickens slowly when exposed to the air. It is much used as a lubricant abroad, but, not being produced in this country, it is too expensive here to be widely used.

The viscosity of rapeseed oil can be greatly increased by heating the oil and blowing air through it to produce a partial oxidation similar to that which takes place slowly when the oil is exposed to the atmosphere. This product is known as *blown rapeseed oil* and is sold as a lubricant for purposes where high viscosity is desired.

Cottonseed oil, obtained by grinding, warming, and pressing the seeds from which the cotton fiber has been removed, is a fairly satisfactory lubricant for many purposes but as it has "semi-drying" properties it thickens more rapidly on exposure to the air than do the oils above mentioned, and so has more tendency to gum the bearings. For this reason and because of the large demand for cottonseed oil as a food and as a material for making high grade soaps it is not likely to become very prominent as a lubricant. On account of its similarity to rapeseed oil it has been used as an adulterant of the latter. *Blown cottonseed oil* is prepared in the same manner and used for the same purposes as blown rapeseed oil.

Castor oil is also somewhat used as a lubricant for cases in which high viscosity is required. In obtaining the oil the ground castor bean is first pressed at ordinary temperature to obtain the first quality ("cold-drawn") oil which is used medicinally, after which by heating the residue and subjecting it to further pressure a darker oil of lower quality is obtained which is used for industrial purposes. As a lubricant it is rather expensive but has the advantage of not readily "drying" or "gumming" nor does it turn rancid so readily as do most fatty oils. It differs from most fatty oils in that it does not mix with petroleum oils.

For descriptions of other fatty oils, less commonly used as lubricants, see Allen's Commercial Organic Analysis or Lewkowsch's Oils, Fats and Waxes.

Tests¹ and Specifications for lubricating oils usually relate to the nature of the oil, its freedom from acidity, grit, tendency to gum, etc., and especially to the specific gravity, flashing and burning points, solidifying point ("cold test") and viscosity.

The significance of the specific gravity as an aid in duplicating an oil which has proven satisfactory in use has already been noted. Flashing and burning points must of course be sufficiently high to ensure the safety of the oil in use, and the solidifying point sufficiently low so that the oil is not likely to congeal at any temperature to which it may be exposed while on the bearing. While much stress is laid upon the viscosity, it is unfortunate that viscosity values are based upon so many types of apparatus that care must be observed in comparing such figures and often quantitative comparisons cannot be made. The adoption of the Engler viscosimeter²

¹ For a recent discussion of tests with full directions for laboratory work see Sherman's Methods of Organic Analysis, Revised Edition, Chapter XI.

² See detailed sketch and description in Sherman's Organic Analysis, p. 227; or Allen's Commercial Organic Analysis, III, 154.

as the standard instrument by the American Society for Testing Materials and its prescription in the United States government specifications will, however, do much in clearing up the confusion arising from the use of different instruments and standards of measurement.

SOLID LUBRICANTS

For the lubrication of low speed bearings under heavy work, *greases* are often used, while *graphite* by itself also serves as a lubricant. Most lubricating greases are made by treating a fatty oil or fat with an alkali whereby a soap is obtained which when mixed with the rest of the oil or with a mineral oil makes the latter stiff and greasy.

The *lubricating greases* may be classified under a few heads, depending upon their consistency, which is derived from the proportion of lime or soda soaps or oleates mixed with a hydrocarbon oil as a carrier. The principal kinds, according to Gillett ¹ are:

A. The tallow type: made from tallow and the sodium soap of palm oil and mixed with mineral oil.

B. The soap-thickened mineral oil type: consists of mineral oil of various grades made solid by the addition of lime or sodium soaps.

C. Types A or B with the addition of a mineral lubricant, usually graphite, mica or talc.

D. The rosin oil type: rosin oil thickened by lime to which is added mineral oil. These greases often contain 20 to 30 per cent water and constitute the chief gear greases.

E. Non-fluid oils: thin greases stiffened with aluminum oleate or a mixture of sodium and calcium soaps.

¹ *J. Ind. Eng. Chem.*, 1, 351 (1912).

F. Special greases, such as a mixture of wood pulp and graphite, thin greases containing wool or cotton fibers, etc.

For an example of the first type the composition of a sample of axle grease may be quoted:

| | <i>Per cent</i> |
|------------------|-----------------|
| Tallow..... | 23.3 |
| Mineral oil..... | 7.8 |
| Dry soap..... | 16.3 |
| Water..... | 52.6 |

Rosin oil is a very common constituent of greases. It is a product obtained from the destructive distillation of rosin which in decomposing yields: (1) an aqueous acid liquor, (2) rosin spirit, (3) rosin oil, (4) coke.

The acid liquor is used as a source of acetic acid, the rosin spirit is a good solvent for use in varnish making, while rosin oil is used as a lubricant as well as for other purposes. In considering this oil attention should be called to the fact that rosin oil is not a fat and contains no fatty acid. It does however contain rosin acids which in the commercial oil are free and make the oil acid in character and which when neutralized with alkali form "rosin soaps."

The soaps used in the manufacture of the greases may be either of the lime or so-called alkali character. The latter consist of those soaps made with caustic soda as the saponifying agent. They generally give smoother greases since they are more soluble in the other oils than are the lime soaps. The latter are cheaper, give a stiffer grease, and have a higher melting point.

The following table of analyses¹ of commercial greases may be taken as representative of the composition of the lubricating greases now in general use:

¹ *J. Ind. Eng. Chem.*, 1, 357 (1909).

TABLE 21.—Analyses of Lubricating Greases

| Name of Grease | Flash point °C. | Melting point °C. | Calcium soap % | Other thickeners % | Water % | Saponifiable oil | Free acid % | Mineral oil % | Coefficient of friction at end of 3 hours | Average value of coefficient of friction during 3 hours |
|--------------------|-----------------|-------------------|----------------|--------------------|---------|------------------|-------------|---------------|---|---|
| Graphite | 195 | 93 | 11 | 16a | Trace | 17 | 0 | 56 | 0.108 | 0.097 |
| Summer motor | 160 | 87 | 38 | | 0.05 | 25 | Trace | 36.5 | 0.075 | 0.075 |
| Winter motor | 175 | 86 | 23 | | 0.03 | 37 | 6.1 | 40 | 0.063 | 0.063 |
| Auto ... | 190 | 79 | 19 | | 1.0 | 20 | Trace | 60 | 0.046 | 0.046 |
| Tallow A | 210 | 52 | | 1.4b | 2.5 | 73.5 | 0 | 22 | 0.012 | 0.022 |
| Tallow XX .. | 215 | 49 | | 32.1c | Trace | 48 | 0 | 20 | 0.018 | 0.029 |
| Lime rosin.. | 198 | 77 | | 9.9d | Trace | 0 | 0 | 0 | 0.017 | 0.048 |
| Soda grease | 215 | 83 | | 22.0e | 0.0 | 0 | 0 | 0 | 0.016 | 0.019 |
| Non-fluid oil. ... | 210 | 76 | 9.8 | 12.9f | 0 | 7 | 0 | 70.3 | 0.016 | 0.026 |

a—graphite.

b—potash soap.

c—potash soap and paraffin.

d—calcium oxide.

e—sodium soap.

f—sodium soap.

Graphite serves as a lubricant for cast iron bearings, acting as a surface evener of the porous metal. On finer surfaces it does not work so well, having a tendency to collect in such quantities as to seriously score or abrade the journal and bearing. To serve as a suitable lubricant under this latter condition, Acheson has prepared graphite in a very fine and deflocculated state which remains suspended indefinitely in water. This form is known under the commercial name of

“aquadag,” and a similar suspension on oils is known as “oildag.” In these forms graphite may be distributed in minute quantities to journals and bearings and under high speed conditions maintains a low coefficient of friction.

REFERENCES

I

- ALLEN: Commercial Organic Analysis, Vol. III.
ARCHBUTT AND DEELEY: Lubrication and Lubricants.
BRANNT: Petroleum.
DAVIS: Friction and Lubrication.
ENGLER AND HOEFER: Das Erdöl. Seine Physik, Chemie, Geologie, Technologie, und seine Wirtschaftsbetrieb (German, five volumes).
GILL: Short Handbook of Oil Analyses.
GILPIN: Crude Petroleum.
HICKS: Laboratory Book of Mineral Oil Testing.
HOLDE: Untersuchung der Schmiermittel (German).
HOPKINS: The Oil Chemists' Handbook.
HURST: Lubricating Fats, Oils and Greases.
LEWKOWITSCH: Chemical Technology and Analysis of Oils, Fats, and Waxes.
MARTIN: The Petroleum Fields of Pacific Coast of Alaska. U. S. Geol. Survey, Bulletin 250.
REDWOOD: Lubricants, Oils and Greases.
REDWOOD: Petroleum and its Products.
ROGERS AND AUBERT: Industrial Chemistry (Article on Petroleum by T. T. Gray and on Lubricating Oils by A. H. Gill).
SHERMAN: Methods of Organic Analysis (Revised Edition).
UBBELOHDE: Handbuch der Chemie und Technologie der Oele und Fette.
U. S. Senate Document, No. 469. 60th Congress, 1st Session. Plans for International Standards of Testing Mineral Oil (1908).

II

- ACHESON: A New Lubricant, Deflocculated Graphite. *Eng. News*, 58, 127 (1907).
HYDE: Characteristics of Natural Graphite. *Eng. Min. J.*, 85, 255 (1908).
MABERY AND MATHEWS: Viscosity and Lubrication. *J. Am. Chem. Soc.*, 30, 992 (1908).

- DALTON: Origin of Petroleum. *Economic Geology*, **4**, 603 (1909).
- GILLETT: Analyses and Friction Tests of Lubricating Greases. *J. Ind. Eng. Chem.*, **1**, 351 (1909).
- CONRADSON: Laboratory Tests of Lubricants. *J. Ind. Eng. Chem.*, **2**, 171 (1910).
- FILS: Manufacture of Lubricating Oils. *Petroleum*, **5**, 1165 (1910).
- GILLETT: Comparison of Lubricating Greases. *Power*, **32**, 1998 (1910).
- GOSS: Oils and Lubricants. *Modern Power*, **1**, No. 4 (1910).
- KISSLING: Examination of Crude Petroleum and its Products. *Petroleum*, **5**, 505 (1910); *Chem. Abs.*, **4**, 1365 (1910).
- MABERY: Lubrication and Lubricants. *J. Ind. Eng. Chem.*, **2**, 115 (1910).
- WATERS: Action of Sunlight and Air upon some Lubricating Oils. *J. Ind. Eng. Chem.*, **2**, 451 (1910).
- WILBUR: Origin and Distribution of Petroleum. *Min. World*, **33**, 1039 (1910).
- DAY: The Production of Petroleum in 1910. U. S. Geol. Survey (1911).
- WATERS: Effect of Added Fatty and other Oils upon the Carbonization of Mineral Lubricating Oils. *J. Ind. Eng. Chem.*, **3**, 812 (1911).
- Solidified Gasolene. *Cal. Oil World*, **3** (42) 8 (1911); *Chem. Abs.*, **5**, 2426 (1911).
- BREGER: Origin of Petroleum. *Min. World*, **35**, 1219, 1321 (1911).
- MEISSNER: Comparison of the Engler, Redwood and Saybolt Viscosimeters. *Chem. Rev. Felt-Harz. Ind.*, **19**, 30, 44; *Chem. Abs.*, **6**, 1544 (1911-12).
- NASTYUKOV: Chemical Composition of Lubricating Oils. *J. Soc. Chem. Ind.*, **30**, 201 (1911).
- SCHWARZ AND SCHULTER: Automobile and Gas Motor Lubricating Oils. *Chem. Ztg.*, **35**, 413 (1911).
- SOUTHCOMBE: Deposits Resulting from Lubrication of Engines. *J. Soc. Chem. Ind.*, **30**, 261 (1911).
- ALLEN AND JACOBS: Methods for the Determination of Water in Petroleum and its Products. *Proc. 8th Intern. Congr. Appl. Chem.*, **10**, 17 (1912).
- CAMERMAN: The Testing of Oils for Superheated Steam Cylinders. *Proc. Int. Assn. Testing Materials*, **2** [10], XXI (1912).
- CHRISTIAN: Lubrication in Coal Mining Practice. *Ind. World*, **46**, 702 (1912).
- CONRADSON: Apparatus for the Examination and Study of the Behavior of Valve and Cylinder Oils and Other Petroleum Lubricating Oils in Saturated and Superheated Steam, Carbon Dioxide, Air and Other Gases. *J. Ind. Eng. Chem.*, **4**, 744 (1912).

- ELLIS: Relation between Temperature and Viscosity of Lubricants. *Met. Chem. Eng.*, **10**, 546 (1912).
- GRAY: A Comparison of the Engler and Saybolt Viscosities of Mixed Oils. *Proc. 8th Intern. Congr. Appl. Chem.*, **10**, 153 (1912).
- MICHAEL: The Critical Examination of Lubricating Oils. *Petroleum*, **6**, 2238 (1912).
- UBBELOHDE: Theory of the Friction of Lubricated Machine Parts. *Petroleum*, **7**, 773, 882, 938; *Chem. Abs.*, **6**, 1986, 2521 (1912).
- FARAGHER: A Standard Viscosimeter and Standard Methods of Determining Viscosities. *J. Ind. Eng. Chem.*, **5**, 167 (1913).
- WESTCOTT: Lubricating Value of Cup Greases. *J. Am. Soc. Mech. Eng.*, **35**, 1143; *Chem. Abs.*, **7**, 3020 (1913).

CHAPTER VIII

THE MANUFACTURE OF PIG IRON

THE annual production of pig iron in the United States is approximately twenty-five million tons, which involves the use of from thirty-five to fifty million tons of iron ore. In the smelting of iron ore in 1909 more than three hundred industrial plants or blast furnaces were engaged, while the refining processes used to convert the pig iron into commercial forms suitable for the various industrial uses constitute an equally large enterprise and make the iron industry one of leading magnitude.

In the reduction of the ore to metallic iron it is necessary to consider the nature of the ores used, the preparation of the ores for smelting (reduction), the general design of blast furnace equipment, the reactions of the smelting process, and the classification or grading of the various kinds of pig iron produced, together with the nature and uses of the by-products of the process.

IRON ORES

The ores used in the manufacture of iron are classified by the United States Geological Survey ¹ as follows:

1. Hematite, including all anhydrous sesquioxides of iron (Fe_2O_3) known by various names, such as red hematite, specular ore, gray ore, oölitic ore, etc.

2. Brown ore, including the varieties of hydrated sesquioxide of iron ($\text{Fe}_2\text{O}_3\cdot n\text{H}_2\text{O}$) recognized locally as limonite, brown iron ore, bog ores, pipe ores, etc.

¹ Mineral Resources of the United States (1905).

3. Magnetite, including those ores in which the iron occurs as magnetic oxide (Fe_3O_4), generally known as magnetic iron ore.

4. Carbonates, those ores which contain a considerable amount of iron carbonate (FeCO_3), such as spathic ore, blackband, siderite, etc.

Of these classes hematite has always been predominant as an ore of iron. At present it constitutes almost nine-tenths of the iron ores produced. Brown ore and magnetite are far inferior in importance, each furnishing at present about one-twentieth of the total, while the production of iron carbonate constitutes less than one-thirtieth of one per cent of the total iron ore production.

Hematite is found in various forms as massive, granular, crystalline, or earthy. It is often associated with silica in veins and beds and as a constituent of siliceous and feldspathic granites. Hematite shows a red streak when scratched.

Brown ore belongs to the more recent deposits of iron, being derived from the more ancient ores by chemical and physical influences. It is also formed from the decomposition of minerals containing iron, washed out by water, mechanically transported to other localities by streams, and precipitated in the hydrated form. This explains the formation of bog iron ore, but it is also found in large beds, in isolated masses, in stalactite form, in distinct nodules, in fine grains, and in the condition of a powder. Its streak when scratched is yellow or brown.

Magnetite is usually black in color, has a definite crystalline form, and is strongly magnetic. Magnetites usually occur in rocks which have undergone metamorphic change and share to a large degree the history of igneous rocks. Various theories regarding the formation of magnetite have been advanced.¹ They often contain quantities of iron pyrite disseminated through them.

¹ Kemp: Ore Deposits of the United States and Canada, p. 182.

Carbonate ores are generally found in connection with lime, magnesia, and manganese. They occur usually in crystalline form and have a yellow to brown color. On exposure to the air, carbonate ores are easily oxidized to brown hematite. The name given to the purer kinds of carbonate ores is siderite or spathic iron ore.

The deposit of ore may occur in beds conforming to the general stratification of the region, in pockets, or in veins or lodes. The accompanying material is known as gangue or country rock. Accordingly, when iron ores are mined, we have three classes of material: (1) Rich ore which is ready for smelting, (2) impure ores which may be subjected to mechanical treatment and the iron concentrated, and (3) the gangue or country rock, carrying a quantity of iron but not sufficient to pay for the cost of extraction.

SMELTING

The preparation of ores for smelting consists in (1) weathering, i. e., exposing to air, which facilitates separation of clays and shales and (2) calcination or removal of volatile matter by heat. This reduces the weight 20 to 50 per cent, removes sulphur, and makes the ore more porous. The reactions taking place are:

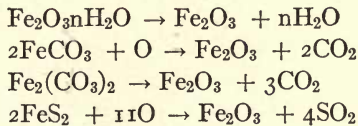

The smelting of iron ores is a reduction process. Its simplest case is that of the action of a reducing agent on an oxide as

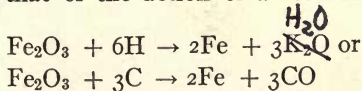

In practice, however, it is necessary to provide also for the removal of the gangue or impurities which accompany the

ores. For this purpose fluxes are used to promote the separation of the metal by increasing the fluidity of the gangue or the ore, and the ash of the fuel, forming a fusible slag. Limestone is the most common of the fluxes used, the lime combining with the silica and alumina of the ore to form fusible complex silicates of alumina and lime. The selection of a flux depends on the nature of the gangue to be removed. Chemical action of the fluxes is dependent on the basic or acid condition of the gangue. Lime, alumina, and oxide of iron are basic, while quartz, sand, and clay are acid. To remove silica or clay it is necessary to add a basic flux, while if metallic oxides or basic bodies have to be fluxed, silica must be added, and possibly a second metallic oxide, to produce a fusible body.

The products of smelting are metals, slag, and gases, the metals in the case of iron ores consisting of all the iron in the ore together with from 5 to 8 per cent of other materials taken up from the charge. The following diagram may be used to show the distribution of the charge and the output of the furnace.

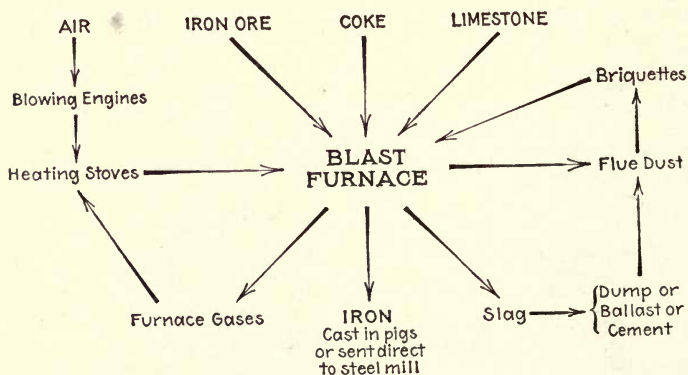

The smelting of iron ore is carried on in an oven known as the blast furnace. This resembles a circular shaft from 85 to

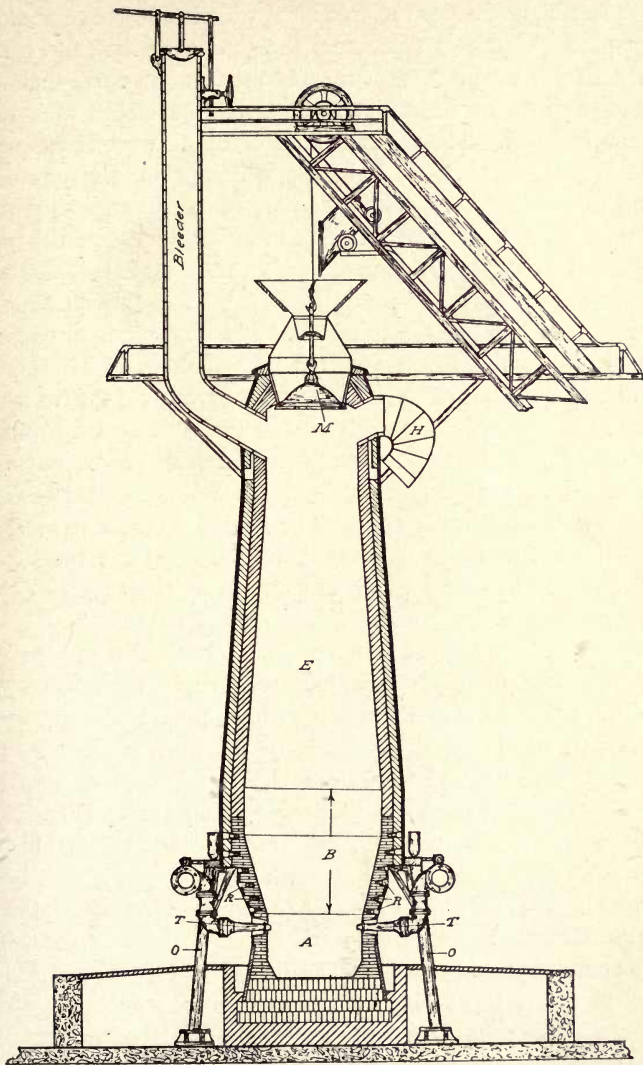

FIG. 37. Blast Furnace.

110 feet high and from 14 to 22 feet wide inside at the broadest part. Figure 37 represents the general outline and construction of the blast furnace. It consists of an outer shell of wrought iron or steel plates, lined on the inside with refractory brick. The internal lines of the furnace constitute the hearth (*A*), bosh (*B*), belly (the widest part of the furnace) and the stack (*E*), which is the part of the furnace tapering from a diameter of about 14 feet to about 10 feet at the top where the charging is done through a removable bell-shaped cover known as the charging bell (*M*). The furnace lining is from 3 feet to 5 feet in thickness. The upper structure rests upon an annular ring supported by pillars (*O*). The bosh lining is not nearly as thick as the other portions of the furnace and in some types it has given way to water cooled bronze plates (*R*), set in the brickwork. The bosh narrows at an angle of about 72 degrees until the hearth is reached where the actual smelting is done. The hearth or crucible of the furnace is circular in section. Into this open apertures for introducing the blast which are known as the tuyères (*T*). The number of tuyères varies from four to sixteen.

In one of the largest furnaces 60,000 cubic feet of air per minute is introduced through sixteen tuyères (diameter 6 inches, the normal pressure being fifteen pounds).¹

A part of the gases produced in the process are led off through pipes descending from the top known as down-comers (*H*) and are conducted to heating stoves (Fig. 38) where they are burned and used for heating the air blast. These stoves are composed of brick checker work which becomes highly heated by the gases of combustion (the mixture of blast furnace gas and air) and serves to heat by contact the cool air passed over it. The line of arrows seen in Figure 38 shows the various channels through which the air, known as the cold blast, travels after entering the brick stove at the top as indicated. The direction of the cold blast in

¹ *Eng. Mag.*, 22, 495 (1902).

being heated is directly opposite to that taken by the gas coming from the furnace to heat up the walls and various

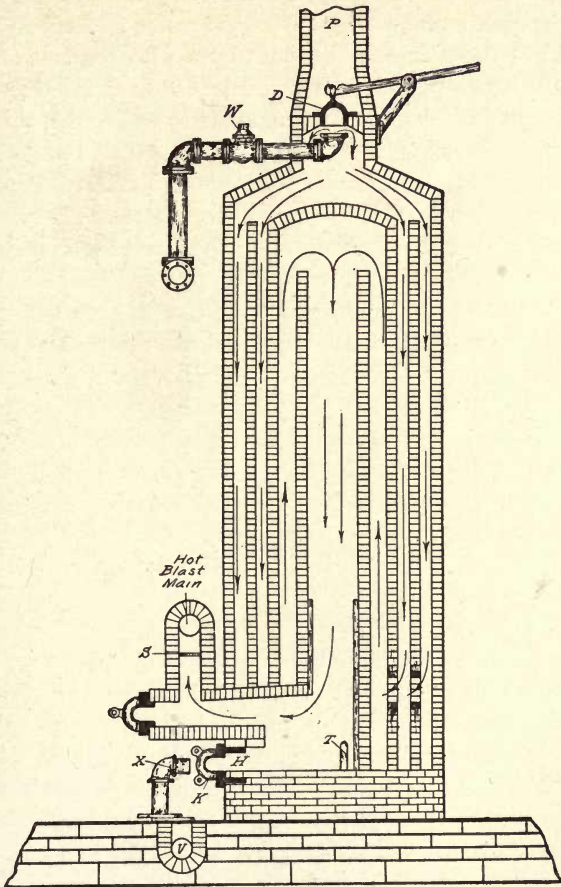

FIG. 38. Heating Stove for Air Blast.

channels and checkered brickwork in the stove. The gas in leaving the "down-comer" is carried through gas mains

to *V*, where it passes the gas valve at *X*, and enters the furnace at *H*. Before the gas is turned on, the cap *K*, which closes the gas inlet while the blast is passing through the stove to be heated, is removed, and the gas valve opened, so that the end of the pipe at *X* is about even with the face of the gas inlet. The pipe *X* being smaller in diameter than the hole of the gas inlet at *H*, permits air to unite with the gas as it enters the stove, thereby causing combustion or ignition of the gas at the entrance before it passes to the combustion chamber, where it receives more air by means of the air inlet *T*, which is opened when the gas is turned on. When the gas is first turned on, the valve *D* is opened. As shown now it is closed so as to prevent any gas escaping up the chimney *P*. The valves *S* and *W* are closed when the gas is on. In a general way the blast is on for one hour and the gas for three. Three stoves are generally on gas while one is on blast. After the air is heated to about 1000° C. it is compressed and distributed by the tuyères in the hearth of the furnace and produces the temperature necessary for the reduction of the iron ore.

CHEMICAL REACTIONS IN BLAST FURNACE

In general, the following is an outline of the reactions: The compressed air at 1000° C. produces from the fuel a mixture of gases, such as carbon monoxide, hydrogen, etc., which assist in reducing the ore and in burning produce a high temperature. The limestone combines with the foreign matter mixed with the oxide of iron in the ore forming a fluid slag which is tapped out every two hours. The molten metal in a crude state (about 93 per cent iron, the remaining 7 per cent consisting of carbon, silicon, manganese, phosphorus and sulphur) is drawn off at intervals of four hours for a "cast," or else run into ladles for immediate use in steel making. The blast furnace may be regarded as a gas pro-

ducer of large dimensions in which air strikes white hot coke. The following reactions may be produced:

- (1) $C + O_2 \rightarrow CO_2$
- (2) $C + CO_2 \rightarrow 2CO$
- (3) $C + N \rightarrow CN$ (slightly)

Hence the gases present in the lower part of the furnace in the region of the tuyères are chiefly carbon monoxide (reducing) and free nitrogen (inert).

When iron oxide descends in the blast furnace and reaches a temperature of $250^\circ C.$ to $400^\circ C.$, the following reactions take place, all of which are exothermal (heat producing):

- (4) $3Fe_2O_3 + CO \rightarrow 2Fe_3O_4 + CO_2$
- (5) $Fe_3O_4 + CO \rightarrow 3FeO + CO_2$
- (6) $FeO + CO \rightarrow Fe + CO_2$

At a higher temperature ($400^\circ C.$ to $500^\circ C.$), and lower in the furnace the following endothermal or heat absorbing reactions take place:

- (7) $Fe_2O_3 + 3C \rightarrow 2Fe + 3CO$
- (8) $Fe_3O_4 + 4C \rightarrow 3Fe + 4CO$
- (9) $FeO + C \rightarrow Fe + CO$

Under certain conditions of temperature and dilution of gas, carbon dioxide acts as an active oxidizing agent thus:

- (10) $FeO + CO_2 \rightarrow Fe_2O_3 + CO$ (exothermal)
- (11) $2Fe + 3CO_2 \rightarrow Fe_2O_3 + 3CO$ (endothermal)

The deposition of carbon is represented by the following reactions:

- (12) $2Fe_2C_3 + 8CO \rightarrow 7CO_2 + 4Fe + C$
- (13) $Fe + CO \rightarrow FeO + C$
- (14) $2Fe + CO_2 \rightarrow 2FeO + C$

This may perhaps be made clearer by considering a concrete case under the following conditions:

Temperature at tuyères, $1500^\circ C.$

Ore = 60 per cent iron; no water, 3,613 pounds ore per ton of iron

Coke = 87 per cent carbon; 1888 pounds per ton of iron

Stone = 100 per cent calcium carbonate; 1010 pounds per ton of iron

Pig iron 4 per cent carbon and 1 per cent sulphur.

Ratio of tunnel head gases: 1 part carbon dioxide to 1.5 parts carbon monoxide

Temperature of tunnel head gases, 260° C.

Height of furnace, 90 feet.

At the tunnel head, i. e., entrance to down-comer, the ore, Fe_2O_3 , is plunged into a mixture of gases consisting of carbon monoxide, 24 per cent, carbon dioxide, 16 per cent, and nitrogen, 60 per cent. A part of the iron oxide is reduced according to equation (4), i. e., Fe_3O_4 is formed. At a depth of ten feet equation (4) is complete and the temperature is 450° C. At a depth of 13.5 feet at 500° C. equation (5) is complete. The ferrous oxide, FeO , 26.5 feet, the temperature being 700° C., and according to equations (6) and (9) yields spongy iron which reaction is complete at 800° C. and at a depth of 32 feet. The limestone descends to this point and is decomposed at 800° C. to lime, CaO , and carbon dioxide, CO_2 . The lime combines with the silicious matter and is rendered fluid. The carbon dioxide is reduced between 17 feet and 32 feet at 550° C.–800° C. to carbon monoxide, the bulk of which escapes and serves no purpose so far as the reduction of iron is concerned. The temperature steadily rises, increasing the fluidity. At the tuyères the following reactions take place:

$\text{O}_2 \rightarrow \text{CO}_2 \rightarrow \text{CO}$, from 4 feet above tuyères to 32 feet.

$\text{SiO}_2 \rightarrow \text{Si}$, by action of carbon at high temperatures in presence of iron. Silicon combines with iron.

$\text{MnO}_2 \rightarrow \text{MnO}$ by $\text{CO} \rightarrow \text{Mn}$ by $\text{C} \rightarrow$ alloys with iron.

$\text{PO}_4 \rightarrow \text{P}$ in presence of $\text{Si} \rightarrow$ phosphide of iron.

$\text{S} \rightarrow$ liquefied and combines with iron.

In the middle zone of the furnace the oxidizing reactions

(10) and (11) nearly balance the reducing reactions. Complex secondary reactions also occur along with those mentioned above.

PRODUCTS OF THE BLAST FURNACE

The main products are gases, slag, and pig iron. Commercial uses have been found for both the gases and the slag, although formerly they were regarded as waste products.

The composition of *blast furnace gases* varies, but in a general way is similar to producer gas (q. v.). Its general composition may be stated as follows:

Carbon monoxide, 23-27 per cent.

Carbon dioxide, 12-10 per cent.

Hydrogen, 2-3 per cent.

Methane, 3-0 per cent.

Nitrogen, 58-59 per cent.

Its calorific power per cubic foot is about 100 British thermal units. Its theoretical temperature of ignition is 1592° C. The sources of the constituents of blast furnace gases are:

Nitrogen from the blast.

Carbon from coke, and from the carbon dioxide in limestone.

Oxygen from the blast, from the ore, and from the carbon dioxide in the limestone.

Hydrogen from the moisture in the blast.

To eliminate the last and thus save the energy required for its formation from the decomposition of moisture, the Gayley process uses dry air for a blast. The drying is accomplished by passing the air over about 90,000 lineal feet of 2'' pipe containing a refrigerating agent, the moisture being deposited on the pipes as frost. The economic saving effected by this preliminary drying of the air is enormous. The amount of fuel used in the formation of hydrogen is given in the following table:

TABLE 22.—Fuel Consumption Due to Moisture in the Air Blast

| <i>Fahrenheit degrees</i> | <i>Cubic feet of air needed per ton of iron</i> | <i>Pounds of H₂O in 1 cubic foot of sat. air</i> | <i>Pounds of H₂O in air used per ton of pig iron</i> | <i>Calories required to dissociate the steam (1 Kg. = 3333)</i> | <i>Pounds of coke required by dissociation</i> |
|---------------------------|---|---|---|---|--|
| 32° | 100,000 | .000304 | 30.4 | 45,900 | 24 |
| 92° | 112,000 | .00225 | 252.0 | 380,500 | 200 |

The Gayley process has been adopted by a number of furnaces in this country and in Wales. Its chief advantages are an increase of ore burden, a reduction of the load on the blowing engines due to the smaller volume of air, more regular working of furnace and a saving in fuel.

The amount of gas produced is about 140,000 cubic feet per ton of iron where the fuel consumption is 2000 pounds per ton. In a 300 ton furnace this will yield 645,000,000 calories or 42,000 horse power per 24 hours. One-third of this goes to heating stoves, leaving 28,000 horse power to be burned under the boilers for steam raising. In an exceptionally good boiler plant the steam will represent 75 per cent of the energy of the fuel, or 21,000 horse power, which, converted into power in engines of 10 per cent efficiency, will yield about 2100 horse power. If, however, the gas not used in the heating stoves be directed to gas engines instead of being burned under boilers for steam raising, the power developed by 15 per cent efficiency gas engines will be 4200 horse power, an excess of 2100 horse power, a power which is ample to run all the converting plants and rolling mills necessary to convert the pig iron into steel rails.

Blast furnace slag is of variable composition due to variations in the charge. It serves the purpose of carrying off waste material amounting to from 10–30 per cent of the weight of the ore and from 10–15 per cent of the fuel. Limestone

is added to combine with these extraneous materials and the result is a mono-silicate of lime and alumina having an approximate composition of $(3 (2\text{CaOSiO}_2) + 2\text{Al}_2\text{O}_3\text{SiO}_2)$. Its approximate percentage composition is indicated by the following typical analysis:¹

| | | |
|--|-------|----------|
| Silica (SiO_2)..... | 34.48 | per cent |
| Alumina (Al_2O_3)..... | 15.13 | " |
| Lime (CaO)..... | 32.82 | " |
| Iron oxide (Fe_2O_3)..... | 0.76 | " |
| Manganese (Mn)..... | 1.62 | " |
| Magnesia (MgO)..... | 7.44 | " |
| Calcium sulphide (CaS)..... | 2.22 | " |
| Alkalies (Na_2O and K_2O)..... | 1.92 | " |
| Phosphoric acid (P_2O_5)..... | 0.15 | " |

The appearance and composition of the slag is an index of the character of the iron produced. If the slag is of a dark color and very dense it means that the iron produced is low in silicon and high in sulphur with much iron in the slag. A light gray color and porous texture denotes the reverse of the above. High manganese produces a brown or green slag while alumina or alkaline sulphides produce a blue slag. The worst slag is "scouring cinder," of reddish brown color due to a large iron content. This is basic and very corrosive to the furnace lining, dissolving the silica of the bricks.

The slag is usually conveyed to a dumping ground and later used for ballast and roadways. Recently other uses have been found for it. It may be made into mineral wool by the action of steam on molten slag. Its most extensive use is in the manufacture of Portland cement. In this process (q. v.) it is granulated by water, mixed with limestone, ground, burned to a clinker, and again ground. Slag² containing 31-34 per cent silica, 12-15 per cent alumina, 46-48 per cent lime and

¹ West: Metallurgy of Cast Iron.

² *Iron Trade Review*, 39, 17 (1906).

not more than 1.3 per cent sulphur may also be ground, dried, and mixed with lime to form a slag cement.

CLASSIFICATION OF PIG IRON

Pig Iron is classified according to (1) the appearance of its fractured surface and (2) its composition, which limits its use to certain purposes.

Appearance of Fracture.—*White pig iron* presents a fracture that is white, close grained and crystalline in appearance. It is usually the product of a furnace that has not been working well. *Mottled pig iron* has a matrix of white iron with gray spots as the characteristics of its fracture. *Gray pig iron* has a gray fracture. It is soft and easily turned, chipped, or filed. Its carbon has separated as graphite.

The typical or average composition of the various classes of pig iron is shown in Table 23.

TABLE 23.—Composition of Pig Iron

| | <i>White pig iron</i> | <i>Mottled pig iron</i> | <i>Gray pig iron</i> |
|------------------------|-----------------------|-------------------------|----------------------|
| Iron (Fe) | 94.68 p. ct. | 94.48 p. ct. | 92.37 p. ct. |
| Carbon (C). | | | |
| Combined | 3.83 “ | 1.98 “ | 0.13 “ |
| Graphite | “ | 2.02 “ | 3.52 “ |
| Silicon (Si) | 0.41 “ | 0.56 “ | 2.44 “ |
| Phosphorus (P) | 0.04 to 0.5 “ | 0.19 “ | 1.25 “ |
| Sulphur (S) | 0.05 to 0.3 “ | 0.08 “ | 0.02 “ |
| Manganese (Mn) . . . | 0.10 to 1.5 “ | 0.67 “ | 0.28 “ |

Composition.—Pig iron is further classified according to its composition which determines its special uses. *Foundry iron* which has a low sulphur content is used in the construction of castings. *Charcoal iron* is exceptionally pure especially in its freedom from sulphur and phosphorus. It is used in the construction of guns, stoves, and chilled work. *Bessemer*

iron, which does not exceed 0.1 per cent in phosphorus may be employed in the manufacture of acid Bessemer steel (q. v.). *Basic iron* which has a high phosphorus content is used in the manufacture of open hearth steel (q. v.). Several special iron alloys are sometimes included among these classes, among them being *ordinary ferro silicon*, a pig iron containing from 10 to 20 per cent silicon; *silicon eisen*, a ferro silicon with a high manganese content; and *spiegel eisen*, which contains a low silicon content but has a manganese content of 7 to 30 per cent.

REFERENCES

I

- ALLEN: Metallurgical Manual of Iron and Steel.
BLAIR: Chemical Analysis of Iron.
CAMPBELL: Manufacture and Properties of Iron and Steel.
HATFIELD: Cast Iron in the Light of Recent Research.
HOWE: Iron and Steel and other Alloys.
LEITH: The Mesabi Iron Bearing District of Minnesota, U. S. Geol. Survey, Monograph, v. 43 (1903).
MCWILLIAM AND LONGMUIR: General Foundry Practice.
TIEMAN: Iron and Steel.
STOUGHTON: Metallurgy of Iron and Steel.
WEST: Metallurgy of Cast Iron.

II

- BIRKINBINE: Mexican Charcoal Blast Furnaces. *Cassier*, 29, 3 (1905).
GREINER: The Utilization of Furnace Gases. *Cassier*, 33, 68 (1907).
THWAITE: The Blast Furnace as a Center of Power Production. *Cassier*, 33, 23 (1907).
Malleable Cast Iron. *Eng.*, 88, 669 (1909).
BROWN: Calculations Pertaining to Reactions Occurring in a Blast Furnace. *Met. Chem. Eng.*, 8, 663 (1910).
EAKINS: Chemistry of Cast Iron. *Iron Age*, 85, 1146 (1910).
EDWARDS: Theory of Hardening Steels. *Eng.*, 90, 548 (1910).
JOHNSON: Manganese Steel Castings. *Foundry*, 37, 243 (1910).
KEMP: The Supply of Iron. *Chem. Eng.*, 13, 5, (1910).

- LANDIS: The Blast Furnace of the Bethlehem Steel Co. *Met. Chem. Eng.*, **8**, 231 (1910).
- PORTER: Physical Properties of Cast Iron. *Chem. Eng.*, **12**, 118 (1910).
- STUTZ: Thermite Practice in America in Welding, Casting and Metallurgy. *Eng. News*, **64**, 200 (1910).
- HAGAR: The Utilization of the Wastes of a Blast Furnace. *Met. Chem. Eng.*, **9**, 407 (1911).
- LANG: Influence of Manganese on the Properties of Iron. *Metallurgie*, **8**, 15 (1911).
- SAVOIA: Production of Malleable Cast Iron. *J. Soc. Chem. Ind.*, **30**, 214 (1911).
- STOUGHTON: Changes in Iron and Steel Making. *Eng. Mining, J.*, **91**, 38 (1911).
- GAYLEY: The Story of the Dry Blast Process. *Met. Chem. Eng.*, **11**, 71 (1913).

CHAPTER IX

COMMERCIAL FORMS OF IRON AND STEEL

THE product of the blast furnace known as pig iron may be used in founding, in puddling, and in converters, yielding cast iron, wrought iron, and steel, respectively. Cast iron contains practically all of the impurities of pig iron; wrought iron is nearly pure iron; and steel contains varying proportions of carbon and other elements as may be desired for specific purposes.

CAST IRON

In the founding process the pig iron is melted either in a cupola, or in an "air furnace." The cupola consists of a cylindrical shaft furnace (Fig. 39), with tuyères for a small blast. The cupola is fired and the iron introduced in layers alternating with coke. About two hundred pounds of coke per ton are required and enough limestone (about 35-40 pounds per ton) is added to flux the ashes of the fuel and form a slag. The chemical changes in the cupola are not very marked, consisting of the partial removal of impurities by oxidation and the absorption of some impurities from fuel.

When pig iron is heated in an oxidizing atmosphere, the silicon is oxidized to silicate of iron and passes into the slag. The amount of carbon is not usually reduced, possibly on account of its being replaced from the fuel as fast as oxidized. But the condition of the carbon is changed from graphite to combined carbon, as the silicon is removed, and consequently the iron becomes whiter. Manganese is partially removed by oxidation. Sulphur present in the fuel passes

into the iron. The effect of the melting of iron is therefore to reduce the percentage of silicon and manganese, increase

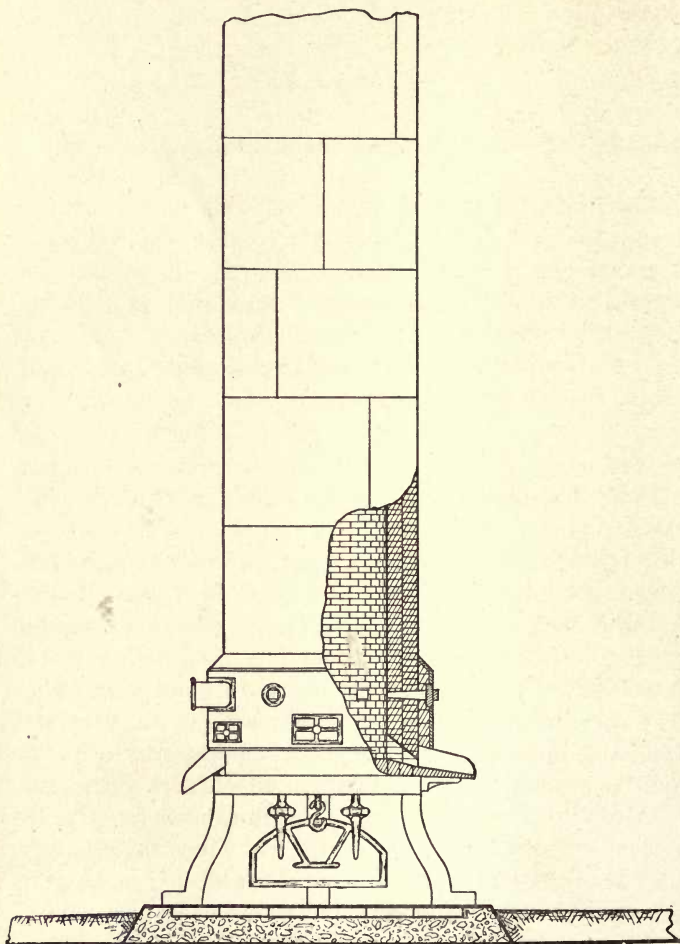

FIG. 39. Foundry cupola.

that of sulphur, transform free carbon into combined carbon, and whiten the iron.

The molten iron is next run into sand moulds of the shape desired for commercial use. The form is obtained from a wooden pattern of the object to be cast. The sand used in moulding has an important influence on the appearance and quality of the castings produced in the foundry.

Moulding sand should have the following approximate composition: silica 92 per cent, alumina 6 per cent, oxide of iron 1.5 per cent, and lime .05 per cent. The higher the proportion of silica, the more refractory is the sand, but it is then apt to lack in cohesion and plasticity. Alumina and magnesia impart the latter properties, but when present in excess render the mould less porous and less refractory. Lime also reduces refractoriness and is apt to produce rough surfaces on castings due to the action of gases from the decomposition of the carbonates. The physical condition of the sand likewise has an important bearing. When too coarse the surface of the casting is inferior; when too fine it is unsuitable for large castings and the gases cannot readily escape.

Chilled castings are made by means of part iron moulds and part sand moulds. The iron that comes in contact with the iron mould is quickly solidified and the carbon does not separate out as graphite, but remains in the combined form. Thus the rims of car wheels cast in this way are very hard, while the interior portions have the properties characteristic of ordinary castings.

When castings of white iron are reheated, packed in some refractory material such as iron ore or mill scale, the iron is rendered soft and somewhat malleable. The change is due to the breaking down of the combined carbon and its separation as amorphous carbon. This form of carbon differs from graphite (in its effect) in that the graphite occurs in gray iron in the form of large brittle sheets whereas the amorphous carbon or "temper carbon" occurs in isolated dust-like patches.

WROUGHT IRON

Wrought iron is a slag-bearing iron, malleable in all ranges of temperature, and not appreciably hardened by sudden cooling. It is made from pig iron either by the process of puddling or a similar purification process. In the puddling process as practiced in this country a small reverberatory furnace (Fig. 40) is used. This furnace consists of a firebox and grate whose area is about one-half of the area of the hearth. The hearth is about 6 feet long and three feet wide and is protected by a lining or fettling (layer) of either roasted

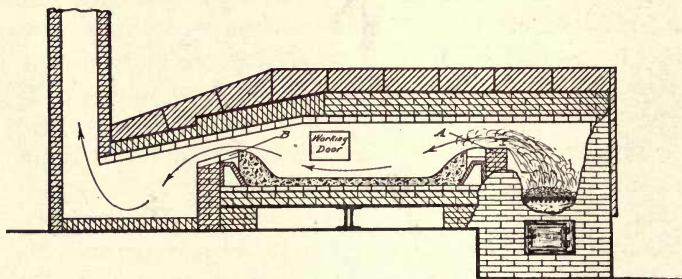
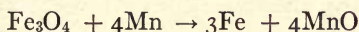

FIG. 40. Puddling Furnace.

tap cinder or roll scale, which is largely iron oxide. The fire and flue bridges, *A* and *B* respectively, are air cooled and the iron plates, which constitute the exterior part of the furnace, are water cooled. The draught is produced by tall stacks and controlled by dampers. Soft coal is the fuel and the charge consists of refining slag (from a previous puddling charge), 500-300 pounds pig iron, together with hammer scale (Fe_3O_4). The process consists of four stages: (1) the melting down stage, (2) the stage of slag formation, (3) the boiling stage, (4) the balling up stage.

The melting is done as rapidly as possible, with forced fires and takes from 30 to 35 minutes. The next 10-15 minutes

constitutes the period of slag formation proper. The damper is lowered, roll scale or high grade iron ore is added and the charge is thoroughly mixed in order to bring the molten iron in contact with the oxide. The first foreign constituent to oxidize is manganese. The molten iron is covered by a slag of silicate and oxide of iron and rests on a bed or fettling of oxide of iron. Hence, the manganese may be removed as in the reaction:



the resulting oxide of manganese becoming a portion of the slag. Similarly the silicon and carbon of the pig iron are removed as represented by the reactions

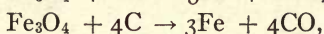
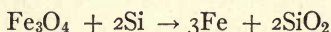

the latter when burning being known as "puddler's candles."

The next stage, lasting for 10-20 minutes, is known as the boiling stage, in which oxidation continues, the rabbling becomes more vigorous and the draught is increased to liquefy the slag. The mass has the appearance of active boiling and bright patches of burning iron are seen, indicating that the iron has "come to nature." This means that the impurities of the iron have been removed by oxidation, and, since the fluidity of iron is dependent upon these impurities especially the carbon, it follows that the iron separates out of solution in granules which coalesce to form the "bloom," or crude malleable iron, suspended in liquid slag.

The last twenty or thirty minutes constitute the balling up stage in which the pasty mass, at full welding heat, is made into balls of seventy pounds each, rolled up to the fire bridge, the damper being lowered, and held in a reducing atmosphere until ready for removal to the squeezer.

The chemical changes are due mainly to the fettling and roll scale (oxides of iron). Sulphur is removed principally

by liquefaction. The loss of iron is about 5–20 per cent and each ton of puddled iron requires about 2500 pounds of coal. The most active agent, chemically, in the puddling is the fettling. A mixture of ferric oxide and silica, made by roasting the slag from the puddling furnace, going by the name of "bull-dog," is often used for fettling. Its oxidizing power is evident by its action on carbon: $\text{Fe}_2\text{O}_3 + 2\text{SiO}_2 + \text{C} \rightarrow 2\text{FeSiO}_3 + \text{CO}$. The tendency is to use fettling of low silicon content, such as hematites. The oxygen of the fettling material and of the slag has been found to be the active agent in the oxidation of impurities in crude iron, rather than the oxygen of the air.

After removal from the puddling furnace the balls of iron containing much slag are passed to a squeezer where the slag is worked out, and then through rolls, leaving bars of malleable iron ready for use.

Malleable iron is of a light gray color with either a granular or fibrous fracture and has a specific gravity of 7.60 to 7.90 (that of chemically pure iron is 7.844). Its composition is evident from the following samples submitted to the United States Government for analysis:

| | <i>Minimum</i> | <i>Maximum</i> |
|---|-----------------|-----------------|
| | <i>Per cent</i> | <i>Per cent</i> |
| Carbon..... | .026 | .064 |
| Phosphorus..... | .065 | .232 |
| Silicon..... | .028 | .182 |
| Manganese..... | Trace | .052 |
| Slag..... | .674 | 1.738 |
| Ultimate strength, 52,201–69,779 pounds to square inch. | | |

The effects of impurities are very marked in wrought iron, the presence of sulphur, arsenic and copper rendering it red short, i. e., it crumbles under the hammer at red heat, while phosphorus renders it cold short, i. e., it may be worked while hot, but when cold breaks on bending.

Steel

Steel may be defined as iron, owing special properties to carbon or other elements, which is malleable in some range of temperature and is either (1) cast into an initially malleable mass, or (2) is capable of hardening when suddenly cooled, or (3) both.

In general, there are four ways in which steel may be produced:

1. By a direct process from iron ores by the Catalan forge, or by the American Bloomery, not usually employed.
2. From malleable iron by the cementation process and crucible process.
3. From pig iron by the acid Bessemer, basic Bessemer, basic open hearth, and acid open hearth.
4. By a combination of the open hearth or Bessemer and the electric furnace.

Cementation Process.—This process is dependent upon the fact that when iron is heated in contact with carbon the carbon travels into the metal and combines with it. The furnace used in this process consists of an arched chamber along the center of which runs the firebox. On each side of the firebox is a trough for the bar iron, so placed that the flames from the fire circulate under and around it. The bars are usually about 10' x 3" x $\frac{5}{8}$ " and the charging is as follows: charcoal lumps are spread over the bottom of the trough; then a layer of the bars; this is covered with charcoal, and so on until filled. Over the top is placed a layer of wheel-sward (grindstone refuse) which fuses and makes a binding for the top. Gradual heating then follows, until in forty-eight hours, the temperature is up to 1100–1200° C., the cementation point. This temperature is kept up for from six to nine days, according to the amount of carbon it is desired to impart to the iron. Thus at the end of four or five days, the bars consist of a thin skin of steel with a core of the

original iron. This steel is used for springs and saws. In five or six days the steel skin is thicker and furnishes shear steel. In seven or eight days it is half core and half steel. In ten days no core or sap is present and it is known as tool steel.

The bars thus produced are known as blister steel on account of the appearance of the surface, due to the carbon monoxide formed from the carbon of the iron and the oxygen of the slag. The cause of the transference of carbon is somewhat in doubt. It is known that under certain conditions solid carbon can diffuse into iron, but it seems more likely to be accomplished by the medium of gases. The atmosphere of the bar troughs consists of carbon monoxide. It is known that iron at high temperatures can absorb eight to ten times its volume of carbon monoxide, but when iron is red hot it will dissociate it thus: $2\text{CO} \rightarrow \text{CO}_2 + \text{C}$. Hence the carbon is deposited and the carbon dioxide diffusing out is reduced thus: $\text{CO}_2 + \text{C} \rightarrow 2\text{CO}$. The various hypotheses advanced are:

(1) carbon is transferred to the interior of the bars from solid fuel, (2) from gaseous carbon monoxide, or (3) from hydrocarbons, the latter hypothesis being supported by the fact that the alkaline cyanides give up their carbon to iron and that iron may be carbonized when heated with paraffin vapor of coal gas.

To secure homogeneity, blister steels are usually either reheated and rolled or broken up and melted in a crucible.

Case hardening is the name applied to the process of converting the surface of soft or medium steel articles into hard (high carbon) steel so that the article may have a hard surface to take the wear and a tough interior to stand shocks and strains. The process of case hardening is very similar to that of making blister steel, namely, by cementation. Harveyizing is case hardening applied to armor plates.

The Crucible Process.—This process in principle consists in (1) melting wrought iron in graphite or clay pots with carbon and any other alloying element desired; (2) tranquilizing the mass so as to yield compact castings; and (3) casting or teeming into ingots.

The graphite crucibles are most commonly used in this country. They are made of graphite about 50 per cent, fire clay 40–45 per cent, and sand 5–9 per cent. They hold a charge of 60–90 pounds and last 4–6 melts, the charges being lessened in each heat.

The clay crucibles, which contain about 5 per cent coke dust, have to be heated carefully. They are not much used in the United States.

Various types of furnaces are used, known as the Sheffield Coke Shaft furnace, American Four Pot Anthracite Shaft and Siemen's Regenerative Crucible Furnace (q. v.). The crucible is filled when cold, and is covered with charcoal. The "heat" consists of two periods: the melting and the killing. The melting takes about two hours and fifteen minutes. When melted, the crucible is uncovered and the charge examined to make sure it is entirely molten. If cast at this state, it would be full of blow holes, so in the *killing* period it is held molten in the crucible until it is quiet. This change is supposed to be due to the absorption of silicon from the walls of the crucible, increasing the solvent power of iron for gases. The casting is done by pouring into moulds and is known as *teeming*.

The chemistry of this process is dependent upon the reaction between the charge and the walls of the crucible. Oxygen is present in rust, in the slag of bar iron, in the air, in carbon dioxide and in water vapor. Hence the tendency to form oxides must be resisted by the carbon in the crucible. The metallic oxides are basic and corrosive, but after reacting on the crucible walls the slag becomes acidic by absorption of silicon. The carburizing action now begins, the result being

that the metal gains in carbon from zero per cent to 0.25 per cent and in silicon from 0.05 per cent to 0.20 per cent. When spiegel or ferro manganese is added, much of the manganese is slagged off (i. e., oxidized and introduced into the slag) and the absorption of carbon may be increased up to 2 per cent and of silicon up to 0.50 per cent.

In clay crucibles the gain in carbon and silicon is very slight. When charcoal is added to the charge the iron is protected from oxidation and the process shortened.

Bessemer Acid Process.—The principle of the Bessemer process is the decarburization and desiliconizing of pig iron by the action of an oxidizing atmosphere.

The Bessemer converter (Fig. 41) consists of a pear shaped shell of wrought iron or steel $\frac{3}{4}$ " to 1" thick with a trunnion ring for mounting. One trunnion is hollow to introduce the blast; the other is attached to pinions for rotation through 180° to 300° . The interior is lined with ganister or some other refractory material. The bottom consists of an air chest (*A*), from which perforations, the tuyères (*B*), pass into the interior.

The converter is heated, turned on its side slightly more than 90° , and three to ten tons of molten iron introduced into the converter. A blast of 20-30 pounds pressure is then turned on, the converter raised to an upright position, and the process of oxidation is begun. An increase of temperature due to the combustion of silicon to silicon dioxide is noticeable, together with an abundance of yellowish flame and sparks. The luminosity gradually diminishes to a pale amethyst tint and after a total blow of twenty minutes suddenly diminishes or drops. The metal, now similar to malleable or bar iron, is poured into tanks or ladles. A weighed quantity of spiegel or ferro manganese is next added to bring up the carbon and manganese content, so as to give the desired temper and malleability.

The chemistry of the Bessemer process is analogous to that of the puddling process, except that the temperature is much

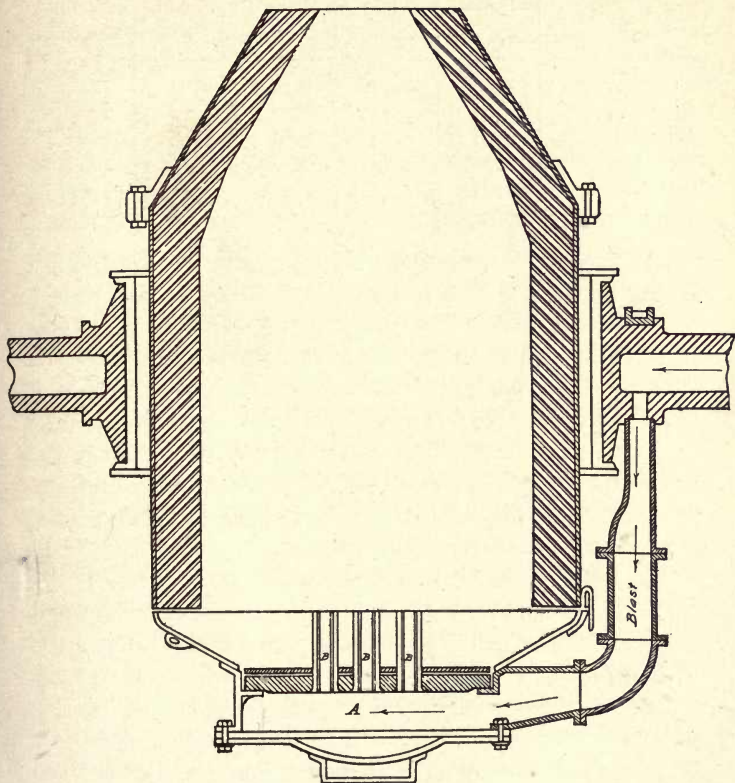

FIG. 41. Bessemer Converter.

higher and the agitation more vigorous. The nature of the change is evident from the analyses of samples taken at the intervals given in Table 24.

TABLE 24.—Changes Undergone by Iron in the Bessemer Acid Process

| | <i>Initial</i> | <i>4 min.</i> | <i>8 min.</i> | <i>16 min.</i> | <i>After addition of manganese</i> |
|---------------------|----------------|---------------|---------------|----------------|--|
| Carbon . . . p. ct. | 2.98 | 2.71 | 0.53 | 0.04 | 0.450 |
| Silicon. . . . " | 0.94 | 0.33 | 0.03 | 0.02 | 0.038 |
| Manganese " | 0.43 | 0.04 | 0.01 | 0.01 | 0.150 |
| Phosphorus " | 0.10 | 0.104 | 0.107 | 0.108 | 0.109 |
| Sulphur. . . " | 0.06 | 0.06 | 0.06 | 0.06 | 0.059 |

The process of oxidation may be represented by the following equations: $\text{Mn} + \text{Si} + 3\text{O} \rightarrow \text{MnSiO}_3$, $\text{Fe} + \text{Si} + 3\text{O} \rightarrow \text{FeSiO}_3$, and probably $2\text{Fe} + 3\text{O} \rightarrow \text{Fe}_2\text{O}_3$; next $\text{C} + \text{O} \rightarrow \text{CO}$, which at the mouth of the converter becomes $\text{CO} + \text{O} \rightarrow \text{CO}_2$. Finally it is necessary to remove the oxide of iron left after the blow ceases. This is done by adding spiegel or ferro manganese. The manganese combines with the oxygen of the ferric oxide to form manganese dioxide and passes into the slag, while the carbon of the spiegel enters the iron and thus converts it into steel.

The heat of combustion upon which this process is dependent is as follows: Take a pig iron of 2 per cent silicon and 3.5 per cent carbon. The calorific power of silicon is 14,000 B. t. u., hence every 100 pounds of iron will evolve 28,000 units from the combustion of silicon. Likewise the calorific power of carbon is 4350 B. t. u. if burned to carbon monoxide; hence for each one hundred pounds of iron, the heat evolved will be $3.5 \times 4350 = 15,225$ B. t. u. About 2 per cent of iron is also oxidized ($\text{Fe} = 4300$ B. t. u.), giving 8600 B. t. u. or a total of 51,825 units for one hundred pounds, or in a charge of ten tons, the heat evolved is 11,608,800 B. t. u., the equivalent of about 700 pounds of coal burned completely in twenty minutes and producing a theoretical rise in temperature equal to 329°C .

Bessemer Basic Process.—The Bessemer process may be carried out either in a converter having an acid lining, as above described, or it may have a basic lining, in which case the process is suitable for the partial elimination of phosphorus. In the Bessemer acid process the limit of phosphorus is 0.1 per cent in pig iron, while in the basic process, pig iron carrying 2-3 per cent phosphorus is used.

The essential points of difference between the Bessemer acid and basic processes are in the lining of the converter and in the after blow. For the lining of the basic converter, a magnesium limestone, dolomite, is burned to expel the carbon dioxide, then ground to a coarse powder, mixed with anhydrous tar, and moulded into the required form. The bottom of the converter is made by ramming the mixture round a series of pins, which when removed leave air holes or tuyère openings in the bottom. The function of such a lining is to be inert so far as the reactions which take place within the converter are concerned.

The process requires the use of 15 per cent lime which is added first, then the iron run in, the converter turned upright, and the blow commenced. The flame is darker in color and the chemical changes are harder to judge. At the end of fifteen or twenty minutes the flame drops, indicating the removal of carbon as before. Little phosphorus has, however, been removed, so the blow is continued a few minutes longer to oxidize the phosphorus. This "after blow" is characterized by a dense red smoke due to the oxidation of the iron. To ascertain whether the blow is complete, a sample is taken, from the fracture of which it is ascertained whether the phosphorus is completely eliminated. The slag is next run off, the ferro manganese added and the steel cast into ingots as before.

The chemistry of the basic process is somewhat different owing to bases present. Silicon oxidizes very rapidly to form calcium silicate. Manganese oxidizes more slowly on

account of silicon not reacting with its oxide in this case. The oxidation of carbon is practically the same in both processes. After the carbon is removed the phosphorus is attacked, passing into the slag as $\text{Ca}_3\text{P}_2\text{O}_8$, or possibly as $\text{Ca}_4\text{P}_2\text{O}_9$. The nature of the changes is indicated in Table 25.

TABLE 25.—Changes Undergone by Iron in the Bessemer Basic Process.

| | <i>Initial</i> | <i>2 min.</i> | <i>5 min.</i> | <i>10 min.</i> | <i>15 min.</i> | <i>19 min.</i> | <i>Spiegel added</i> |
|-------------------------|----------------|---------------|---------------|----------------|----------------|----------------|----------------------|
| Carbon p. ct. | 3.21 | 3.30 | 3.12 | 1.49 | 0.05 | | 0.26 |
| Silicon " | 1.22 | 0.72 | 0.15 | 0.012 | 0.008 | 0.004 | 0.01 |
| Phosphorus " | 2.18 | 2.15 | 2.22 | 2.096 | 1.91 | 0.087 | 0.14 |
| Sulphur " | 0.08 | 0.047 | 0.051 | 0.051 | 0.055 | 0.056 | 0.04 |
| Manganese " | 1.03 | 0.71 | 0.50 | 0.16 | 0.01 | | 0.48 |

The slag contains 30 per cent $\text{Ca}_3(\text{PO}_4)_2$ and 10 per cent oxides of iron. The source of heat when an iron of 1 per cent silicon, 3.5 per cent carbon and 3 per cent phosphorus is used is as follows:

| | | |
|---------------------|--------------------------------------|-----------------|
| 1 pound of silicon | oxidized to SiO_2 | 15,000 B. t. u. |
| 3.5 pounds " carbon | " " CO | 15,225 " |
| 3.0 " " phosphorus | " " P_2O_5 | 31,110 " |
| 4.0 " " iron | " " FeO | 17,200 " |

Total heat generated is 77,535 B. t. u. per 100 pounds of iron, or a charge of ten tons yields 18,367,840 B. t. u., the equivalent of 1000 pounds of coal. All the Bessemer steel in the United States, however, is made by the acid process, and constitutes about one-third of the total steel production.

Acid Open Hearth Steel.—This process consists of the melting and treatment of pig iron by exposure to flames on a hearth of silica in the presence of an acid slag. The furnace (Fig. 42) used is constructed on the regenerative principle.

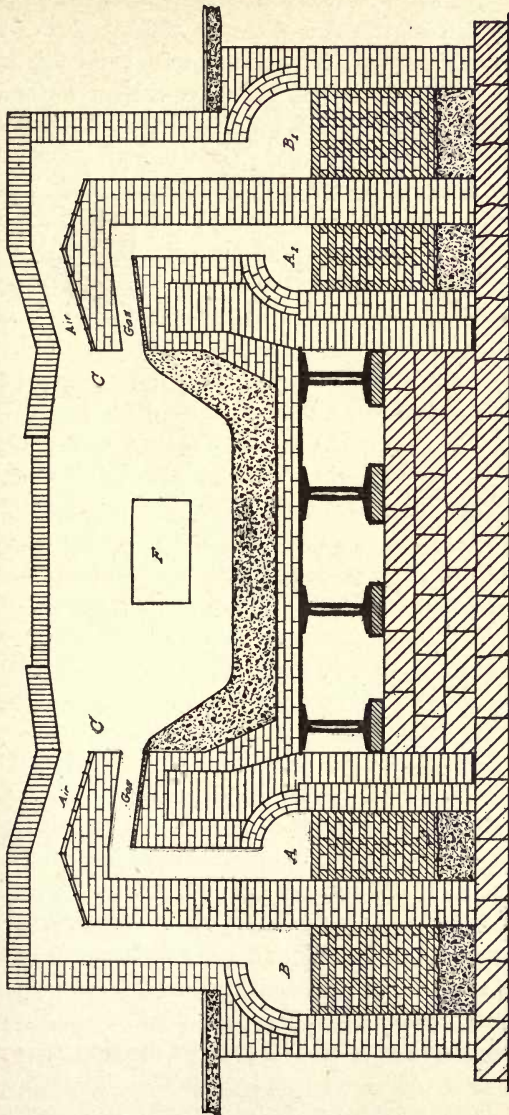

FIG. 42. Open Hearth Furnace.

The hearth of a fifty ton furnace is 14' x 30' x 30''. Instead of a fireplace, it is provided with gas and air ports. Each furnace is provided with four regenerators, two being in use while two are heated. Air enters above the gas in the combustion chamber and is mixed with latter at a distance of five feet before reaching the charge. The flame acts similarly to a blowpipe, containing one-third excess air and hence is oxidizing. The temperature of 1050° to 1100° C. is regulated by admission of air and gas. The gas enters the chamber (*A*), which is surrounded by thick walls and filled with brickwork so laid that a large amount of heating surface is exposed, while at the same time free passage of gas is assured. The air enters a similar chamber (*B*). In starting a furnace the bricks in these chambers are heated before any gases are admitted. The first effect of their entrance is to cool the chambers on the incoming end, for no heat is produced until they meet in the port (*C*). From this point the flame warms the furnace and also the chambers (*A*) and (*B*), through which the products of combustion pass to the stack. After the brickwork in the first set of chambers has been partially cooled by the incoming gases, the currents are reversed and the gas and air enter the furnace in the reverse direction, thus in all ways the action is cumulative; and there is an increment of heat throughout the whole operation. The material to be made into steel is charged into the furnace through the working door (*F*). The molten liquid is drawn out through a tap-hole not shown on the drawing. The bottom of the hearth is concave and is so constructed that it can be kept cool. The outer covering is of steel, next two layers of ganister (silica) bricks, and on this the working layer of refractory sand. The roof and outer walls are of steel and lined with silica brick and fire brick. Working doors are placed opposite the charging doors and through these the temperature and stage of the process are judged by the workman.

The process is somewhat similar to puddling on a larger scale, except that a higher temperature is maintained, causing the iron to remain liquid. The charge, consisting of pig iron and scrap of known composition, fills up the hearth to a depth of twenty inches when molten. Oxide of iron, usually red hematite (about 25 pounds per ton of charge), is added in small portions at a time. The ore goes into solution, slag is formed, and a boiling action takes place. When the carbon monoxide has escaped, the boiling ceases, and if the temperature were lowered, the iron would "come to nature." A sample is now taken and its carbon determined colorimetrically. If removal of carbon is complete the whole charge is tapped into a ladle, ferro manganese added,¹ and cast into ingot moulds.

The chemistry of the process is similar to that of the other processes. The first step is the oxidation of the iron. This oxide carries with it some silicon. The oxygen from the hematite ore next oxidizes the silicon to ferrous silicate which enters the slag. Carbon is next oxidized and disappears in the boiling action. Ferro manganese is added and serves the function noted above, viz., removal of oxygen. Carbon is introduced, usually in the form of crushed coal. The operation requires from eight to twelve hours, depending on the total amount of impurities to be removed. The process is similar to the acid Bessemer but is capable of much better control and renders a wider range possible. It secures better homogeneity and is especially adapted to high carbon steels.

Basic Open Hearth Steel.—This process treats pig iron upon a hearth of magnesite in presence of a basic slag. Its object is to make use of iron higher in phosphorus and sulphur than is allowable in the Bessemer process.

The furnace is similar to the one used in the acid open hearth, except that it is lined with magnesia brick. The problem now is: Given a hearth capable of resisting the action

¹ Or the ferro manganese may be added in the furnace.

of metal and slag, how to melt the iron, decarburize it and remove the phosphorus and sulphur.

The charge is usually as follows: Fifty tons of pig iron are run upon 8 to 12 tons red hematite ore (Fe_2O_3). Upon the ore lies a ton of burnt lime to assist in forming the slag. The first reaction is a violent one and lasts only a short time (20 minutes). The following analyses show the nature of the change:

| | <i>Initial</i> | <i>After reaction</i> |
|------------------------|----------------|-----------------------|
| Carbon. p. ct. | 3.50 | 3.00 |
| Silica. " | 2.00 | 0.00 |
| Phosphorus. " | .75 | 0.00 |
| Manganese. " | .50 | 0.00 |
| Iron. " | 93.25 | 97.00 |

The process of decarburization is a longer one. These changes are given below, the charge in this case consisting of twenty tons of pig iron, 6400 pounds of hematite and 2000 pounds of limestone.

TABLE 26.—Changes of Composition of Iron and the Resulting Slag in the Basic Process

| <i>Time</i> | <i>Carbon %</i> | <i>Silicon %</i> | <i>Phosphorus %</i> | <i>Manganese %</i> | <i>FeO %</i> | <i>FeO₃ %</i> | <i>Mn %</i> | <i>P₂O₅ %</i> | <i>SiO₂ %</i> |
|---|-----------------|------------------|---------------------|--------------------|--------------|--------------------------|-------------|-------------------------------------|--------------------------|
| At beginning. | 4.61 | 0.84 | 0.15 | 2.20 | | | | | |
| After 30 min. | 4.56 | 0.19 | 0.05 | 0.45 | 47.88 | 6.10 | 15.22 | 2.36 | 17.68 |
| After 3 hours. | 1.47 | 0.05 | 0.03 | 0.63 | 10.36 | 3.23 | 12.67 | 2.35 | 23.00 |
| 1600 pounds more ore added at this point. | | | | | | | | | |
| After 4 hours. | 0.43 | 0.05 | 0.03 | 0.49 | 11.44 | 2.37 | 12.04 | 2.03 | 22.90 |

The phosphorus combines with the lime to form calcium phosphate, $3\text{CaO} + \text{P}_2\text{O}_5 \rightarrow \text{Ca}_3(\text{PO}_4)_2$, as a constituent of the slag, the latter being run off at frequent intervals. A basic condition is necessary owing to the ease of reduction of iron phosphate by carbon as represented in the reaction:

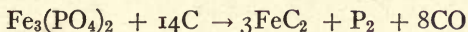

To permanently “fix” and remove the phosphorus the stable phosphate of lime is therefore used for this purpose, as above noted.

The elimination of sulphur is favored by a number of conditions: (1) by addition of manganese, giving rise to manganese sulphide, which is readily fused and passes into the slag; (2) by the use of manganese ore in the original charge, acting similarly as in the preceding; or (3) by the action of lime, favoring the formation of calcium sulphide.

The relative importance of the various processes may be noted in the following statistical table taken from Mineral Resources of the United States for 1906:

| | <i>United States</i> | <i>Germany</i> | <i>Great Britain</i> |
|-------------------------------|----------------------|----------------|----------------------|
| Acid converter | 12,275,253 tons | 407,688 tons | 1,307,149 tons |
| Basic converter | | 6,772,804 “ | 600,189 “ |
| Acid open hearth | 1,321,613 “ | 230,668 “ | 3,378,691 “ |
| Basic open hearth | 9,649,385 “ | 3,534,612 “ | 1,176,245 “ |
| Crucible and special. | 118,500 “ | 189,313 “ | “ |
| Total | 23,364,751 “ | 11,135,085 “ | 6,462,274 “ |

For the year 1909 the following table shows the tendency toward the increased use of basic open hearth steel in the United States:

| | |
|-------------------------------|----------------|
| Bessemer. | 9,330,783 tons |
| Basic open hearth. | 13,417,472 " |
| Acid open hearth. | 1,076,464 " |
| Crucible and special. | 130,302 " |
| <hr/> | |
| Total. | 23,955,021 " |

REFERENCES

- HUDSON: Iron and Steel, an Introductory Textbook for Engineers and Metallurgists.
- Standard Specifications for Steel. Committee on Standard Specifications, American Society for Testing Materials, Phila.

(See also references at ends of Chapters VIII and X)

CHAPTER X

THE INDUSTRIAL ALLOYS

FOR the purpose of definition and classification alloys may be considered as consisting of two or more metals partly or wholly soluble in each other when solid and which may carry compounds formed between the component metals.

These solid solutions are analogous to the everyday liquid solution and are to be considered in the same way. For example, a solution of common salt in water is a homogeneous liquid which may contain from 0 to 26.4 per cent of its weight of salt (at 18° C.). Within these limits therefore the composition may vary and yet the solution will remain perfectly homogeneous. When, however, the quantity of salt exceeds 26.4 per cent, at the temperature noted, both solid and liquid exist and the homogeneity is destroyed. Similarly, solid aluminum (at 380° C.) can hold in solution from 0 to 50 per cent of solid zinc (calculated on the total weight), or, in other words, the alloys of zinc and aluminum which contain between 0 and 50 per cent zinc are, at this temperature, solid solutions of zinc in aluminum.

From the fact that certain combinations of metals have freezing points lower than any other alloys of the same series, it has been common to regard such combinations as chemical compounds, but this view is now quite generally combated and such alloys go under the name of eutectic (easily melting) alloys.¹

While the possible combinations of metals to form alloys

¹For a historical discussion of the term "eutectic" see Desch's *Metallography*, p. 21 (1910).

may be extremely numerous, only a limited number of them possess properties which render them suitable for technical application. Among the properties which make them suitable for such uses are strength, toughness, malleability, elasticity, resistance to shock and corrosion. The alloys which find their largest application industrially are the iron group. Next in importance are the alloys of copper with some other metal or metals. A group of alloys, of considerable diversity of composition known as the bearing metals, is also of technical importance.

For a classification covering the discussion of this subject the following is proposed:

- I. Iron and other elements which give rise to the various grades of cast iron, structural steel, tool steel and special steels.
- II. Copper and tin known as bronze.
- III. Copper and zinc known as brass.
- IV. Copper, tin, antimony, and lead forming the bearing metals or antifriction alloys.
- V. Miscellaneous alloys.

IRON ALLOYS

Since the combination of iron with carbon and other elements constitute the basis of the iron alloys it will be of interest to discuss the characteristic properties of these elements separately.

Pure iron may be prepared by electrolysis of its salts or by reduction of its oxalates by hydrogen. Its specific gravity is 7.67. It fuses at 1500° C. and, when cooled and broken, has a scaly crystalline fracture. It is capable of taking a high polish. It is more malleable than wrought iron but fuses with greater difficulty. It is highly magnetic. It burns easily to Fe_2O_3 , when heated, or, if finely divided takes fire spontaneously (pyrophoric iron). It occludes gases such as carbon monoxide, hydrogen, and nitrogen.

Carbon is a very infusible element with a low specific gravity of 2.26 (graphite) to 2.5 (diamond). It is found in gray cast iron in its *free* state as graphite, being deposited from a saturated solution of carbon in iron during cooling. It imparts a gray color to iron and greatly reduces its strength. It constitutes that part of the carbon content of iron which remains undissolved when iron is treated with a mineral acid. In the *combined* form carbon may exist in iron as a carbide "cementite," a definite compound to which the formula Fe_3C is given, or it may form a solid solution of carbon in iron, in which case it is known as "hardening" carbon, an example of which is found in the process of making steel hard by heating and plunging into cold water. Combined carbon is volatilized in the form of organic compounds by non-oxidizing acids and imparts a brown coloration to nitric acid solutions.

The *amount of carbon* capable of being dissolved in molten iron is 6 per cent at 1400°C . The presence of carbon depresses the melting point of iron, an alloy containing 4 per cent carbon melting at 1100°C ., or 400° below the melting point of pure iron. The presence of other metals in iron facilitates the solution of carbon and use is made of iron manganese alloys as carbon carriers to add the requisite amount of carbon in steel manufacture. Cast iron often contains 5 per cent carbon, steel 0.10 to 1.5 per cent, and wrought iron from 0.25 to 0.05 per cent.

Combined carbon increases the hardness and tensile strength of iron, decreases its toughness and malleability, and renders it liable to crack when suddenly heated or cooled. Hardness must be bought at the cost of ductility, but the decrease of the latter in the case of carbon is not as great as the increase of the former. Thus, for a surgical knife, which must be hard, high carbon steel are used; for bridge steel, subject to sudden jars or shocks, low carbon steel is required; while for a steel rail, where both strength and hardness are

necessary, a medium amount of carbon is required. The effect of carbon on tensile strength of iron is noted in Table 27.

TABLE 27.—Tensile Strength of Iron and Steel

| | | | | | | | |
|--|------|--------------------------|---|---|---|---|---|
| Pure Iron shows a tensile strength of | 17 | tons to the square inch. | | | | | |
| Steel containing 0.18 per cent carbon, | 30.5 | " | " | " | " | " | " |
| " " 0.22 " | 32.5 | " | " | " | " | " | " |
| " " 0.50 " | 45.0 | " | " | " | " | " | " |

Sulphur combines with iron in almost any proportion, and it is absorbed with great avidity from all metallurgical materials. A highly basic slag is necessary for its removal. The presence of sulphur tends to cause the carbon of the iron to be in the combined form. Its physical effects are (1) to induce "red shortness" (non-workable at red heat), and (2) to render iron non-weldable. If manganese is present, the sulphur content of iron may be increased without bad effects. The sulphur limit in Bessemer rails is placed at 0.5 per cent. For cast iron the content may go up to 0.3 per cent if the castings do not require fitting and turning. No marked effect in tensile strength is noted, but its presence causes a sluggish flow of the molten iron and increases the contraction on solidifying.

Phosphorus is another undesirable element, the introduction of which into steel must be guarded against. It produces cold shortness (non-workable in cold), renders iron more fusible, causes it to be more fluid when molten, and causes expansion in solidifying. It renders iron brittle under shock, diminishes the ductility, and produces a coarsely crystalline structure. The usual limit is 0.10 per cent, but this is too high for structural bridge work.

Silicon is always present in iron. Its effect is somewhat uncertain and is dependent on other constituents present. In general it hardens iron, increases its tensile strength and diminishes the solubility of carbon in iron. The usual limit for silicon in steel is 0.3 per cent.

Manganese is always found in steel, and certain alloys of iron contain a high percentage, e. g., ferro manganese contains 20-80 per cent, and *spiegel eisen*, 7-20 per cent, manganese. It retards the separation of carbon as graphite, increases the solubility of carbon in iron, and thus counteracts the influence of sulphur. It increases the tensile strength of steel, but an excess causes brittleness. The standard is .10 to 1 per cent. When the content rises from 1.5 to 2 per cent it makes the steel brittle and worthless but when it reaches 6 to 7 per cent it causes the steel to be not only harder, but very much tougher. Such steel is used for car wheels and dredging links, etc. These manganese steels usually contain 14 to 15 per cent manganese and melt to a very liquid fluid, making good castings of a highly crystalline fracture. In order to overcome brittleness the metal is heated to whiteness and then quenched, becoming hard, tough, and strong.

THE SPECIAL STEELS

Nickel steel is an iron nickel carbon alloy used extensively in the manufacture of armor plate, ammunition hoists, turrets, forgings in marine engines, wire cables, and rock drills. The Krupp armor plate is an alloy of iron containing 3.5 per cent nickel, 1.5 per cent chromium and .25 per cent carbon. Nickel steel is made by adding metallic nickel to molten mild steel. It forges well and easily. It has a fibrous fracture. Nickel increases the tensile strength of steel, gives it a high elastic limit and makes it very tough.

Chrome steel is made by adding ferro chrome to molten mild steel. This alloy does not cast well and does not forge or weld easily. When quenched it becomes very hard and its power of resistance is very great. The amount of chromium is usually about 1 to 2 per cent. Chromium steels become very hard when cooled rapidly and they are therefore used for armor piercing projectiles, armor plate and plate for

burglar proof safes. These steels are also used in motor car construction for gears, usually with nickel. Such a steel, containing besides carbon two alloying elements, is called a quaternary steel. A steel containing besides iron and carbon, one alloying element, is called a ternary steel.

Tungsten steels have the property of being self-hardening; that is, of being hard without quenching or special treatment. When the per cent of tungsten is right the steel can be used as a cutting tool under such severe conditions that the tool is at a red heat. Such a steel is called "high speed" steel. A first grade high speed steel will contain about 18 per cent tungsten, 3.5 chromium, a fraction of a per cent of vanadium, and 0.60 carbon. A tungsten steel containing about 5 per cent tungsten and 0.5 carbon is used for permanent magnets.

Molybdenum produces the same self-hardening and high speed effects as tungsten and is often used in place of and with tungsten. Only about a quarter as much molybdenum is required, however, to produce the same results.

Vanadium in very small quantities improves the physical properties of steel more by reason of its cleansing action on the impurities in the steel than by its action as an alloy. The usual amount of vanadium used is from 0.10 to 0.30 per cent.

Manganese steels when treated are extremely hard without being brittle. For this reason they are much used for rock crushing machinery jaws, dredger buckets, railroad rails under hard service conditions and such uses. The best composition for manganese steel is 12 to 13 per cent manganese and 1 to 2 per cent carbon. The steel is worked hot with great difficulty and is nearly impossible to machine so that it is usually used as cast. This steel when cooled slowly in the air becomes extremely hard and as brittle as glass. To make it usable it is heated to a white heat and quenched in cold water. This treatment makes it tough and at the same time hard.

BRONZE

The bronzes are solid solutions of tin in copper, generally containing less than 12 per cent tin. Alloys of this type are characterized by great strength, elasticity, and toughness. The gun metals are representative of this type. Bronzes which contain above 12 per cent tin are also frequently employed, but require special heat treatment to avoid brittleness. Bell metal which often contains up to 25 per cent tin is an example of this class and its chief characteristic is its great hardness and sonority. In the construction of machinery, bronzes containing 10 to 18 per cent tin and 2 to 4 per cent zinc are employed. The presence of zinc facilitates casting and also modifies the color. Lead is sometimes added to give better fluidity and to modify the oxidation film, or "patina," which forms on the surface and is an important item in art bronzes. For use in coins a bronze is required to take a sharp impression of the die and yet possess sufficient hardness to resist the wear of handling. Such bronzes consist of 95 per cent copper, 4 per cent tin and 1 per cent zinc.

BRASS

The industrial alloys of copper and zinc fall into two classes, consisting of the *brasses* proper and of *Muntz's metal* and similar alloys. Of the brasses an alloy containing 33 per cent zinc is commonly used for casting purposes, whilst the maximum ductility is possessed by the alloy containing only 30 per cent zinc. The latter mixture is capable of withstanding extremely severe mechanical deformation as is illustrated in the formation of a cartridge case from a disk by pressing between dies.

The second group of copper zinc alloys comprise those containing 36 to 46 per cent of zinc yielding alloys which are harder and stronger but less ductile (except at high tempera-

tures) than brass. Muntz's metal contains 40 per cent zinc and is used in constructional work where the metal must be rolled when hot. To increase the tensile strength and facilitate casting, an alloy known as "delta metal" is used in engineering. This is similar to Muntz's metal but contains in addition 1 per cent or more of iron, the latter being held in solid solution.

The manufacture of the copper alloys is usually accomplished by melting copper and adding the tin or zinc in small quantities from time to time, care being taken to prevent undue oxidation (charcoal is sometimes employed to prevent the oxidation of tin) or volatilization of tin and zinc.

BEARING METALS

Although of rather diverse composition, the bearing metals, or anti-friction alloys, may be considered together since they present a general similarity of structure. The requisite property of these alloys is that they shall consist of a hard and a soft constituent so distributed that the soft material provides the necessary plasticity, whilst the harder substance receives the load and resists abrasion. This is generally accomplished by distributing crystals of one or more hard constituents through a soft ground mass, or matrix. The latter is either lead or tin or an eutectic alloy of these metals. The hard constituent is composed frequently of the cubical crystals of tin and antimony, these metals being present in the quantities represented by the formula $SbSn$. Tin is sometimes absent, antimony serving the same purpose as the mixture. Copper may be used as an additional hard constituent in these alloys. The range of composition is very wide and representatives of almost every member of this class are met in practice. Babbit metal containing 45.5 per cent tin, 50 per cent lead, 13 per cent antimony, and 1.5 per cent copper may be taken as a representative of this class of alloys.

MISCELLANEOUS ALLOYS

A number of alloys not included in the classification up to this point are employed for various industrial purposes. A short description of the more important will therefore be given.

Ordinary plumber's *solder* is an alloy of lead and tin in the proportion of 67 per cent lead and 33 per cent tin. *Pewter* contains 8 to 15 per cent lead, the remainder being tin. *Hard lead* used for acid tanks, etc., consists of lead containing 10 to 15 per cent antimony. *Type metal* consists of 20 per cent antimony, 2 to 3 per cent tin, the remainder being lead. *German silver* is a ternary alloy of copper, zinc, and nickel, having the approximate composition of 50 to 60 per cent copper, 15 to 20 per cent nickel, and 20 to 30 per cent zinc. A German silver known under the name of *Platinoid* is largely employed in the construction of electrical resistances. It contains small quantities of tungsten. Another alloy employed for electrical resistance is *manganin* which contains 82 per cent copper, 15 per cent manganese and some nickel and iron.

REFERENCES

I

BECKER: High Speed Steel.

DESCH: Metallography of Industrial Alloys.

GULLIVER: Metallic Alloys.

JOHNSON: Rapid Methods for Chemical Analysis of Special Steels.

LAKE: Composition and Heat Treatment of Steel.

LAW: Alloys and their Industrial Application.

SAUVEUR: Metallography of Iron and Steel.

II

MATTHEWS: Alloys as Solutions. *Eng. Min. J.*, **82**, 819, 851 (1901).

HOWE: An Introduction to the Study of Alloys. *Eng.*, **75**, 647 (1903).

BECKER: Manufacture and Use of High Speed Steel. *Cassier*, **35**, 327 (1908) and **35**, 505 (1909).

- GUILLETT: Special Steel Alloys. *Eng. Mag.*, **36**, 65 (1908).
- BURGESS and ASTON: Alloys of Iron and Manganese. *Electro-Chem. and Met. Ind.*, **7**, 476 (1909).
- EDWARDS AND ANDREW: Aluminum, Copper, Tin Alloys. *Eng.*, **88**, 664 (1909).
- LIPPMANN: The Chemistry of Soldering Agents. *Sci. Am.*, **101**, 389 (1909).
- BENGOUGH: Corrosion of Brass and Copper. *Elect. Rev. West. Electr.*, **58**, 707 (1910); *Chem. Abs.*, **5**, 2064.
- CLAMER: Cupro Nickel Steel. *Eng. News*, **64**, 124 (1910); *Met. Chem. Eng.*, **8**, 527 (1910).
- EWEN AND TURNER: Shrinkage of Alloys during Solidification. *Eng.*, **90**, 678 (1910).
- GIBBS: Vanadium Steel. *Cassier*, **38**, 174 (1910).
- SMITH: High Speed Steel. *Eng. News*, **63**, 459 (1910).
- SPRINGER: Manganese Steel. *Cassier*, **39**, 99 (1910).
- Specifications for Automobile Alloys. *Brass World*, **7**, 126 (1911).
- BOHNY: Application of Nickel Steel in Bridge Building. *Stahl und Eisen*, **31**, 98 (1911); *Chem. Abs.*, **5**, 1055 and 1729.
- SAUVEUR: Metallography and its Industrial Importance. *J. Ind. Eng. Chem.*, **3**, 420 (1911).
- FRIEND: Corrosion of Iron, Steel and Alloys. *Ind. World*, **46**, 670 (1912).
- NORRIS: Vanadium in Iron and Steel Castings. *Eng. News*, **67**, 1100 (1912).
- WALKER: Metallurgy of Molybdenum. *Met. Chem. Eng.*, **10**, 110 (1912).

CHAPTER XI

CLAY PRODUCTS

THE clay working industry of the United States manufactures annually products valued at \$150,000,000 to \$175,000,000.¹

These products are classified by the Geological Survey as common brick, paving brick, drain tile, front brick, ornamental brick, enameled brick, architectural terra cotta, fire-proofing tile, stove lining, sewer pipe, fire brick, and miscellaneous. The latter class includes many special clay products, the most important of which are wares for chemical purposes, chimney flues, conduits, crucibles, insulators, oven tile, and pottery products.

In order to present an adequately clear discussion of clay products without undue detail, it will be sufficient to consider the nature and origin of clay, its physical and chemical properties, and its use in the manufacture of building brick, paving brick, fire brick, tiles, pottery and porcelain.

NATURE AND ORIGIN OF CLAY

Clay is usually defined as an earthy material, which, when mixed with water, becomes plastic, which may be moulded into various forms, and which, when heated to a sufficient high temperature, loses its plasticity and becomes hard. The term clay is used in a very broad sense, representing substances of a great variety of chemical and mineralogical

¹ The clay products for 1910 are valued at \$170,665,974 by the United States Geological Survey.

composition. In a general way, however, we may regard clay as consisting of a plastic mass of silicate of alumina together with other constituents which will be described below.

Clay is formed by the decomposition of various kinds of rock, chiefly through mechanical and chemical agencies. Expansion and contraction owing to temperature changes tend to break up rocks, and develop fissures where water collects and, in freezing, exerts a direct expansive force. The erosive action of flowing streams and the waves beating against headlands; the grinding action of moving glaciers; and the moving influence of strong winds, are all mechanical agents which assist in breaking up the earth's rock crust. Far more powerful, however, are the chemical influences. The solubility of the rock constituents in water; the oxidizing effect of water containing dissolved oxygen which produces new compounds of larger bulk; the solvent action of acids, especially of carbonic acid,—all assist in breaking rock masses into minute fragments. For example, when granite is subjected to these disintegrating influences, the principal minerals released are quartz, mica, feldspar, and hornblende. Quartz and mica are largely unaffected by chemical agencies and remain in the clay, at least if it is not moved from the place of its origin. If the clay is moved, the abrasion of the particles may render them sufficiently fine to form an essential factor in the clay mass. Feldspar is of varying composition, but is essentially a tri-silicate of aluminum and an alkali metal of the general formula $MA\text{Si}_3\text{O}_8$ where, if M is sodium, we have albite; if potassium, orthoclase, etc. When water containing plant acids or carbon dioxide reacts with a feldspar, the change occurring may be represented as follows:

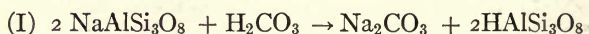

The soluble carbonate, or other salt, is carried by river flow

to the sea and there reacts to form insoluble carbonates, as, for example:

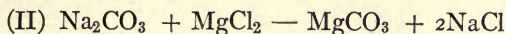

(NOTE: Reaction I is the reversal of the ordinary fusion reaction and II accounts for the huge accumulation of salt in the sea and the immense ranges of stratified carbonates from sea bottom deposits.)

The vast beds of clay everywhere under the soil show the extent to which these reactions have already taken place, and the end is not even in sight, in view of the fact that it is estimated that nearly three-fourths of the known surface of the earth is formed of gneiss and granite containing 60 per cent to 90 per cent feldspar.

CLASSIFICATION OF CLAYS

Various terms are used to describe clays, depending upon their origin, history, purity, physical and chemical properties, and also upon their uses. Orton's¹ shorter classification is as follows:

- I. Primary, or residual clays:
 1. Entirely decomposed feldspathic rock. (Example, kaolin or china clay.)
 2. Partially decomposed feldspathic rock. (Example, English Cornwall stone.)
- II. Secondary, or transported clays:
 1. Deposited in still water.
 - A. Fire clays.
 1. Highly refractory. (Examples, flint and fire clays.)
 2. Moderately refractory. (Example, stoneware clay.)
 - B. Shales.
 1. Slatey shales.
 2. Bituminous shales.
 3. Clay shales.

¹ Iowa Geological Survey, 14, 40 (1904).

2. Deposited from running water.
 - A. Alluvial clays.
 - B. Silicious clays.
 - C. Loamy clays.
3. Deposited by glacial action.
 - A. Glacial clays.
4. Deposited by wind.
 - A. Loess.

Through the kind permission of the author, Professor Edward Orton, Jr., of Ohio State University, we reproduce also the much more detailed and descriptive classification which he has recently published in the form of a privately printed chart.

CLASSIFICATION OF CLAYS (ORTON)

The distinctions made are partly geological, partly mineralogical, and partly utilitarian or trade distinctions.

Clays are mixtures of minerals, or rocks, in which hydrous silicate of alumina is present in sufficient quantity to impart its characteristics to the mass to a sensible degree; and in which no other mineral is present in sufficient quantity to become the characteristic or predominant ingredient. Kaolinite is the most abundant and important of the hydrated alumina silicates, and is usually considered as the "base" or characteristic "clay substance" of clays, but it is rarely found in them in identifiable crystalline form. It is thought by some to be present in colloidal or partially colloidal form, and in this state it is not mineralogically identifiable, nor separable from other hydrous silicates of alumina and similar minerals, which are known to be frequently intermixed with it. All of these hydrous silicate minerals which are blended in the "clay substance" of clays are secondary or derivative minerals, formed by the weathering and hydration of the principal igneous silicates.

Primary Clays are those which have been formed on the spot where they now occur by the weathering or "breaking down" of igneous rocks. The proportions of the minerals composing them therefore depend, 1st, on the composition of the original rock, 2d, on the extent to which the chemical alteration has progressed, and 3d, on the opportunities for removal of the products of the weathering process.

Massive or derived from the weathering of massive rocks.

White or light burning.

Still hard and preserving a more or less rocky structure.

1. **Semi-Kaolinized Rocks.** Feldspathic rocks which have partially weathered and lost some of their alkali, without becoming clay-like. [Example—The Cornwall Stone used by English Potters.] Fusible or vitrifying to a porcelain-like body. Insoluble in ordinary acids. Non-plastic. Used as a dilute flux in place of feldspar.

Soft, easily crumbled, and sometimes plastic and clay-like.

2. **Primary Kaolins.** These occur only in igneous rocks, containing high proportions of alkalis and alumina, and low in iron, such as feldspars, felsite, pegmatite, feldspathic porphyry, granites and rhyolites, occur in a situation favorable to decay and unfavorable to erosion. Such clays are therefore relatively rare and may be valuable. The alkali has been almost wholly removed. Generally infusible.

Generally yield little if any soluble matter by treatment with any acids except H_2SO_4 and HF. When worked up with water, they are generally short and weak, and only feebly plastic. Shrinkage in firing excessive, resulting in shattering by cracks. Generally contain angular grains of quartz and flakes of white mica in considerable abundance. Used as an important ingredient in white pottery and tile bodies, and for paper-filler. [Example, the white clays of Western North Carolina.]

Colored, burning red or yellow.

Still hard and preserving a more or less rocky structure.

3. **Rotten Rocks.** Igneous and metamorphic rocks, partially broken down by weathering, but not plastic or clay-like. Not used as an ingredient in clay mixtures and hence not discussed further. Soft, easily crumbled, and sometimes plastic and clay-like.

4. **Common Primary Clays.** The product of the weathering of rocks originally containing ferrous silicates. These clays are stained in all degrees by ferric hydroxide. They are usually more fusible than kaolins and give up iron readily to acid solvents. Are not very plastic and show high shrinkage in firing. Frequently contain much coarse mineral detritus. These clays are not often valuable for practical purposes. [Example, the red primary clays of the Piedmont Plateau region, east of the Appalachian mountains.]

Faintly stratified or derived from the weathering of stratified layers of comminuted igneous rocks. Usually light burning.

Usually clay-like or soft, easily crumbled rocks.

5. **Aeolian Primary Clays.** Formed from volcanic ash beds, frothy tuff, and scoriae, which are ejected in separate eruptions and fall in successive showers. They are sedimented and to some extent they weather to clays with exceptional ease and rapidity, and often still show the roughly stratified character of the original beds. Beds of rhyolite ash may yield light colored or white clays, but volcanic ashes oftener contain enough iron to prevent their forming clays useful for other than common purposes. When volcanic ash clays contain any coarse or unweathered minerals, these show the volcanic nature of the original material, as they are angular, generally glassy, and but little crystallized. [Volcanic ash clays are of large extent in some regions where volcanic activity has been great, as in Central Washington.]

Secondary clays are those which have been transported from their point of origin, and in which the assortment and proportions of the mineral mixture are therefore due to or influenced by this transportation and sedimentation. They seldom represent the product of decay of any single rock, but are generally the blended products of decay from many rocks and from large areas, assembled chiefly by water and more or less sorted as to size and weight during transit and deposition.

Transported by winds. Aeolian Clays.

6. **Loess:** Believed to be formed by the gradual shifting of fine clays and sands by winds in arid districts. This view is contested by some who consider them of sedimentary origin. All loess clays are not adequately explained by either theory, but the first has the most adherents.

Fine, very sandy clays, fragments usually somewhat sharp and not water worn. Occurring in beds of great thickness with horizontal stratification planes not sharply defined. Clay breaks with a vertical columnar cleavage and forms bluffs like sandstone. In some places the streams form canons with vertical walls. Vegetation leaves vertical root casts filled with lime or fire clay, perforating the clay in great numbers. Remains of land animals frequently imbedded. Type occurrence is in China, but loess occurs largely in the Missouri and upper Mississippi valleys of the United States, and in Northern Germany in Europe.

Transported and sorted by running water and deposited as sediments from stiller waters.

Deposited from comparatively still quiet waters, like the oceans, lakes and ponds.
White Burning.

Secondary Kaolins. Sediments containing or consisting largely of white burning clay matter. They have been transported or sorted by water but without contamination by ferruginous sediments. Plasticity low or wanting entirely.

7. **Non-Kaolinite Clays.** Clays of hard conchoidal fracture, dense horn-like and smooth texture and usually devoid of visible grains of impurities. Supposed to contain other hydrous silicates of alumina than kaolinite, such as Indianaite, Halloysite, Pholerite, Pyrophyllite, etc., as indicated by showing more or less combined water and silicic acid than the kaolinite ratio permits. Such clays may be of primary origin, but they are more often of secondary origin. Of not infrequent occurrence. Of very little industrial importance. Usually unmarketable, or used for alum manufacture or similar cases. [Example, the Halloysite of Northern Alabama.]
Plasticity high or sufficient for working purposes.

8. **Secondary Kaolins.** (a) Sometimes nearly pure, 99% white clay matter, occurring in heavy beds interstratified with sands, fresh water limestones, etc. Capable of use without washing. Refractory. Very plastic and fat. [Example, Dry Branch clay beds, near Macon, Ga.]
- (b) Sometimes mixtures of white clay matter with white quartz and a little mica, yielding as little as 25% of kaolin on purification. Useless, without washing. Refractory. Plastic but rather short. [Example, clays at Edgar, Florida.]
- (c) Sometimes residual clays, left from solution of limestones or weathering of calcareous cherts, and mixed with silica too fine to be capable of removal by washing. Refractory. Plastic, but very short and unworkable. [Example, clays of Glen Allen, Mo.]
- (d) Sometimes containing notable quantities of soluble silicic acid, and alkalis, though soft and clay-like, and showing no evidence of feldspathic nature. These clays vitrify at low temperatures, forming a porcelain-like body. [Example, the kaolin of Edwards County, Texas.]
9. **Ball Clays.** Generally rich in clay matter—70 to 95%—and containing mineral dust in only the finest state of division. Often dark colored and impregnated with carbon or lignite. These clays are commonly of Cretaceous or Tertiary age, and are interbedded with sands, limestones and other sedimentary rocks. They generally vitrify to form dense bodies at moderate temperatures. Similar in occurrence to (8a) but not as pure in color. [Example, the clays of South Western Kentucky.]

**Yellow or Buff-Burning (excepting the calcareous buff-burning variety).
Refractory clays or Real Fire Clays. (No. 1 Fire Clays).
Plasticity low or wanting entirely.**

10. **Flint Fire Clays.** Allied by appearance and behavior to group No. 7. Usually possess a marked conchoidal fracture, like Halloysite, but lacking the pearly luster and translucency. Plasticity either wholly wanting or so low as to require use of other clays as a bond. Composition, usually richer in alumina and lower in silica, than kaolinite. Ascribed by Wheeler to the presence of Pholerite. Presence of bauxite or laterite is more probable reason. Shrinkage in drying, none; in burning very great, with much cracking. Industrial importance, very great. Most important refractory material in use. [Examples, at Olive Hill, Ky., interstratified with plastic No. 2 fire clays. In Missouri, in pockets and sink holes in limestones.] Plasticity good or sufficient.

11. **Bond Clays.** Composed principally of clay substance or of clay substance mixed

with quartz; low in iron oxide or fluxing minerals and hence vitrify slowly and fuse only at high temperatures. They are similar to (9) except in color after burning, which is always buff or yellow. Such clays are rare. They seldom occur in the Carboniferous formation and belong usually to the Cretaceous and Tertiary periods. They are imported to America in large quantities from Germany, for glass pot and crucible manufacture. [Example, the pot-clay of Gros Almerode.]

Vitrifying or Low Grade Fire Clays. (No. 2 Fire Clays.)

Plasticity low or wanting entirely.

12. **Impure Flint Clays.** Relatively rare and unimportant. Have the flint structure, with the mineral make-up of low-grade fire clays. [Example, clays of Tuscarawas Co., Ohio.] Plastic.

13. **Vein Fire Clays.** Composed of hydrous silicates of alumina with quartz, feldspathic and micaceous minerals, ferric oxide and sulphides. They seldom contain any carbonate of lime. They burn buff generally, but the less pure often burn brown, pink or blue. They vitrify at low or moderate temperatures to dense hard and strong bodies. They occur immediately underlying coal veins in coal-bearing formations of all ages, and this association suggests swamp action as influencing their formation. [Example, the Lower Mercer clay at Union Furnace, Ohio.]

14. **Massive or Lens Deposits.** Similar in mineral composition to 13 but resembling 9 and 11 in structure and occurrence. Generally massive. Strata irregular or lacking in persistence. Often soft and cheese-like. Usually of Cretaceous or Tertiary age. [Example, the clays of Metuchen, N. J.]

Dark-Burning Clays (including those calcareous clays which burn yellow or green).

Stratified Marine or Still-Water Clays. Clay sediments, deposited in still deep waters and generally in beds of great extent and thickness. Generally somewhat hardened by heat and pressure, and have a highly developed fissile structure. Initial plasticity usually small but develops by working. Generally fine grained and homogeneous, but containing concretions of iron, lime, &c. Vitrify at low temperature to dense bodies, often becoming exceedingly tough and strong on cooling, but sometimes becoming brittle and glassy. According to their age and degree of metamorphism, they are sub-divided as follows:

15. **Schists.** Metamorphic, crystalline, non-hydrous rocks supposed to have been derived from shales by heat and pressure. Banded structure is the only remaining indication of a sedimentary origin. May be used as building stones, but never as clays.

16. **Slates.** Hard stony shales, partially dehydrated by heat and pressure, but still retaining some clay nature. Fissile structure wonderfully developed. Thin sheets used as roofing materials without burning. Not used in clay working except in a very small degree. Composition like shales, but almost deficient in plasticity. Burning properties like shales.

17. **Shales.** Moderately

to the mass. According as one or other of these admixed minerals is predominant, groups 15, 16, 17 and 18 may be sub-classified as

High in alumina, but not pure enough to burn white. Composition similar to fire clay but structure that of shale. Rather rare. [Example, the Rakonitz shale of Silesia, Germany.]

(a) **Clay-Like or Argillaceous**

The commonest variety of all. All degrees of sandiness from plastic clay-like shales to hard stony rocks of the variety known as "free stones," which contain only a few per cent clay. [Example, the Blue Stone at Newburg, O.] Infusorial earths, containing microscopic silicious shells of marine animals may be classified here also.

(b) **Sandy or Silicious**

Containing carbonate of lime in quantities from one or two per cent up to 80 or 90. The latter characterize the older geological formations. The lime may also be present as gypsum in all amounts from traces up to pure gypsum rock. Clays containing more than 4 or 5% of carbonate of lime or any appreciable quantity of gypsum are usually of little value. [Example, the shales of Southwestern Ohio near Cincinnati.]

(c) **Calcareous**

All marine clays, whether soft or hard, are liable to be admixed with one or more accessory minerals, in amounts sufficient to give character

hard clay strata which have been heated and compressed, but not to the point of chemical alteration. Fissile structure is strongly evident, but not perfect enough to split like slate. They soften and become more or less clay-like on exposure to weather. Often but feebly plastic when first mixed with water but recovering their plasticity by continued grinding. Form the basis of enormous clay industries.

18. Bedded Clays. Soft plastic clay strata whose deposition has been like that of shales but which are too recent to have been hardened by heat or pressure. "Young" shales. Concretionary growths likely to be less than in shales, though often present to some extent. Working properties generally fine. Burning properties like shales. Such clays valuable but rather rare.

The iron content of red burning clays usually runs from 4 to 7% ferric oxide and is very constant, representing the mean of the secondary rocks of the earth's crust. By concentration, or chemical precipitation, the iron may increase locally until the clay is reckoned as an iron ore. [Example, The clay-iron-stone of England, and the black band ore of Ohio.]

(d) Ferruginous

Marine clays ordinarily contain from one-half to two per cent of carbonaceous matter and are colored gray or blue. When much more carbon is present the color becomes black. Ordinary black shales carry from 3 to 6%, sometimes 10 or 15%. Bone coal contains 70 or 80% carbonaceous matter, but has a shaly structure. The carbon in clays may be woody tissue, peat, lignite, coal, anthracite, graphite or bitumin. The former are granular and do not affect the plasticity. Bitumin forms an artificial bond which hardens the clay and destroys plasticity and also interferes seriously in burning. Small percentages of granular carbon are not considered injurious. Bituminous clays are generally avoided. [Example, the Huron shale of Ohio.]

(e) Bituminous

Bog Clays. Impure clay-sediments, collected in shallow or stagnant waters and marshes, and usually high in precipitated minerals and salts, which may be crystallized, diffused or concretionary. Generally of recent geological age. Beds generally of small extent and non-continuous. Soft and unconsolidated, except where infiltrated with crystalline minerals. Massive, without fissile structure.

Residual Clays. Left from limestone, saline, and gypsum beds after removal of soluble portions by percolating waters.

22. **Leached Clays.** Full of debris indicating kind of rock removed. Usually red. Worthless as clays. Good soils.

Alluvial Clays. Recent clays deposited along present drainage systems.

23. **Flood plain Clays.** Soft, unconsolidated, and generally massive—fissile structure slight if any. Plastic, easily workable, burning much like shales. Very little chemical precipitation or concretionary growth. Valuable compared to shales but of small extent.

Deposited from running water.

24. **Sandy Clays.** Generally plastic clays which are weak and easily crumble when dry. Burn red or dark and vitrify at low heats and melt at high temperatures. When they contain vegetable mold they are called loam.

25. **Clayey Sands.** Generally plastic but are without cohesion when wet or dry. Wares made from them are very weak. Burn red and dark and stand great heat.

Transported wholly or in part by ice. Moraine materials.

26. **Semi-Glacial or Out-Wash Bed.** Glacial debris which has been more or less transported or sorted by water. Along the edge of an area where glacial agencies are at work there are usually numerous lakes, ponds, rivers, etc., whose existence is temporary and short-lived. By these the glacial debris is more or less reworked and sorted and classified into clays, sands, gravels, boulders, etc. The clays vary from the finest possible sediments, up to sediments so coarse and sandy as to be no longer called clays. They cannot always be identified as glacial clays by studying a hand sample but can be identified by observing their geological occurrence and the nature of the other rocks among which they occur. Even the finest-grained glacial clays often contain occasional coarse pebbles or boulders, dropped into them by floating ice, while in similarly

fine-grained clays of exclusively water borne origin this would be very unusual. [Example, the famous Albany Slip, used as a glazing for crude pottery, is a glacial lake bed deposit.]

27. **Glacial or Till-Beds.** A mixture of all sorts of mineral debris, angular rock fragments, worn or rounded boulders, gravel and fine clay sediments, together with remains of vegetable or animal life. In some places, chemical reactions have produced new minerals in the mass which were not present in the original deposit. [Example, the common surface clays of two-thirds of North America, especially above the 40th Parallel.]

PHYSICAL PROPERTIES OF CLAY

Structure.—Clay deposits show a varied structure. They may be slate-like in formation or occur as shales. Stratified and concretionary deposits are not uncommon. More generally, however, clays are massive, with no definite structure within the deposit itself.

Color.—The color of clay is dependent upon its chemical composition. A pure kaolin is white, but it is rarely found in a pure condition. The red color is due to the iron oxide, hematite; the yellow color, to the hydrated oxide of iron, limonite; the blue color, to ferrous iron; and the green color to silicate of iron. Organic matter imparts a gray to black color. Manganese compounds may also be present as coloring matter.

Weathering.—When air-dried clay is exposed to moisture and air it breaks up into small particles. This action takes place first on the surface but continues until the entire mass is disintegrated. Clays vary greatly in the rate at which weathering takes place, certain shales being very slow or exhibiting minimum weathering.

Plasticity.—As stated in the definition, the characteristic property of clay is plasticity. Clays exhibit great variations of this property, very plastic clays being known as "fat," while the slightly plastic ones are "lean." Many theories have been advanced to explain the cause of plasticity.

The molecular attraction theory¹ assumes that the water added in tempering is sufficient to form around each grain a film not over 0.00005 mm. thick, which is the extreme distance through which molecular attraction can operate. According to this theory, plasticity is caused by molecular attraction, according to the laws recognized by physicists.²

Fineness of grain has been advanced as a cause of the

¹ *J. Am. Chem. Soc.*, **27**, 1046 (1905).

² Carhart's *University Physics*, Part 1, Page 116 (1904 Edition).

plasticity of clay. Dr. Whitney of the United States Bureau of Soils has set the limit ¹ of the size of clay particles at less than 0.005 mm. diameter. If the size of the grain imparted plasticity, finely ground materials should be plastic. Experiments by Wheeler,² Orton,³ and others show that this does not hold and that fineness of grain alone cannot account for plasticity.

The plate theory ⁴ is based upon a microscopical study of plastic clays. In these the most prominent structure is an abundance of small transparent plates and prismatic crystals.

The colloidal theory ⁵ is based upon the power of certain constituents of the clay to absorb salts from aqueous solutions. According to this conception the clay mass consists of a combination of granular and amorphous, or colloidal ⁶ materials. It has been shown by Van Bemmelen ⁷ that the colloidal hydroxides of iron and aluminum show marked absorptive power for salts of the alkalies and alkaline earths. Since plastic clays have the greatest efficiency as absorbents, non-plastics being very inferior in this respect, it is inferred that the plasticity of a clay is due to the colloidal substances which it happens to contain. The ratio between the colloidal and the granular materials, in the terms of this theory, is a measure of the plasticity of a clay.

Cohesive Strength.—Upon this property depends the ability of a clay to be handled before burning. Strength in the

¹ Bull. 4, Bureau of Soils, U. S. Department of Agriculture.

² Missouri Geological Survey, 9, 102.

³ *Brick*, 14, 216.

⁴ Missouri Geological Survey, 11, 104.

⁵ *Trans. Am. Ceram. Soc.*, 6, 65 (1904); also *J. Am. Chem. Soc.*, 25, 457 (1903); also Bulls. Nos. 85 and 92, Bureau of Chemistry, U. S. Dept of Agriculture.

⁶ For a full discussion of this term, the student is referred to Bull. 388, U. S. Geol. Survey (1909) on "The Colloidal Matter of Clay," by H. E. Ashley.

⁷ *Z. anorg. Chem.*, 13, 232 (1906).

unburned clay is also required to enable it to withstand crushing from the weight of the material on top of the lower layers in the kilns. This property of a clay is measured by its tensile strength as determined by standard machines used in cement testing. No great stress can be laid upon these tests on account of the variations in strength of the same clay when different persons make up the briquettes used in testing. Relative values may, however, be obtained when uniformity in testing is observed.

The tensile strength of clays varies from a few pounds per square inch to as much as 350 pounds. Formerly it was held that the tensile strength of a clay was a measure of its plasticity, but this view is not now generally accepted.¹ Tensile strength seems, however, to show a definite relation to the fineness of grain and to the volume of shrinkage.² In general, the determination of the tensile strength of a clay aids in judging its behavior in drying and burning.

Shrinkage.—This property refers to the loss in volume, known as cubical shrinkage, which a clay undergoes in the manufacture of clay products. It is generally described as air shrinkage and fire shrinkage.

Air shrinkage refers to the change of volume owing to the removal of the water (which forms a film around the clay particles) thus bringing the particles closer together. The shrinkage which takes place by air drying amounts to as much as 5 to 7 per cent. Fine grained clays show highest shrinkage. High air shrinkage may, however, also be due to an excess of water used in tempering the clay.

Fire shrinkage of clays varies from 3 to 16 per cent. This change of volume during burning is due to the drawing together of the clay particles under the influence of incipient fusion. The escape of the combined water, carbon dioxide, and other volatile ingredients, with the oxidation of particles

¹ Geological Survey of New Jersey, 6, 83.

² Bulletin 9, Illinois Geological Survey, p. 172.

of solid carbon has left voids which are filled as the clay shrinks. Vitrification ensues upon the perfect closing of the pores. Then follows, more or less rapidly, viscosity and the formation of cells or blebs, to the destruction of the ware.

Specific Gravity.—The specific gravity of clay as determined by the pycnometer method ranges from 2.56 to 2.71, the variations depending on the mineralogical composition of the clay. The specific gravity of the various constituents of clay is given in the following table:

| | |
|-----------------|-------------|
| Kaolinite. | 2.65 |
| Feldspar. | 2.55 |
| Mica. | 2.70 to 3.0 |
| Calcite. | 2.70 |
| Loam soil. | 2.45 |

Porosity.—Porosity may be defined as the ratio, in terms of volumes, of void spaces to solid particles. The amount of pore space determines the amount of water the clay will absorb. Porosity may be calculated from the specific gravity determination and the use of a Seger volumeter. Since the specific gravity is equal to W/V_c , where W is the weight of clay, and V_c the volume which the clay particles occupy, then $V_c = W/\text{sp. gr.}$ If next the volume of the clay mass, V_m , be determined in a Seger volumeter,¹ the volume of the pore spaces, V_p , will be $V_m - V_c$. The fractional amount of pore spaces in a clay mass will be V_p/V_m . Since $V_m - V_c = V_p$ we have $V_p/V_m = W_m - V_c/V_m$ or the percentage of porosity of a clay mass will be $100 (1 - V_c/V_m)$ where $V_c = W/\text{sp. gr.}$ as above.

Fineness.—As before defined, the constituents of a clay are of a variable chemical and mineralogical character. The same variation applies to the size of the particles. The latter may be determined by the methods of mechanical analysis,²

¹ See Ries: Clays, Occurrence, Properties and Uses, page 133.

² See Bulletin 24, Bureau of Soils, U. S. Dept. of Agriculture.

which employs microscopical measurements. In the following table are given the percentage amounts by weight of the clay particles, grouped according to the diameters, of a number of clays.¹ The loss on ignition has been first determined in each case.

| <i>Diameter</i> | <i>1 mm.</i> | <i>1-.1 mm.</i> | <i>.1-.01 mm.</i> | <i>.01-.001 mm.</i> | <i>Less than .001 mm.</i> |
|-----------------|--------------|-----------------|-------------------|---------------------|---------------------------|
| Sample 1 | 6.92 | 6.19 | 54.24 | 22.92 | 7.87 |
| “ 6 | 1.14 | 1.74 | 63.17 | 23.49 | 7.62 |
| “ 10 | 0.85 | 2.09 | 22.96 | 40.72 | 23.93 |
| “ 14 | 13.66 | 5.76 | 41.24 | 24.34 | 8.14 |

Fineness of grain exerts an important influence on many properties of clay. Plasticity, shrinkage, tensile strength, porosity, and fusibility are all affected by the fineness of the clay particles.

Fusibility.—From a practical standpoint this represents the most important criterion as to the utility of a clay. The physical factors influencing fusibility are chiefly its homogeneity and its fineness. The chemical composition of a clay, however, exerts the greatest influence upon the temperature at which fusion takes place.

CHEMICAL PROPERTIES OF CLAY

The chemical composition of pure clay may be represented by the hydrated silicate of alumina ($\text{Al}_2\text{O}_3, 2\text{SiO}_2, 2\text{H}_2\text{O}$). This portion of the clay is known as the “clay substance” and is soluble when treated alternately by hot sulphuric acid and sodium carbonate.

This silicate sometimes occurs in crystalline form and is then known as kaolinite. Kaolin is a white clay of weak plasticity. It is highly refractory and sometimes approaches

¹ From Bulletin No. 9, Illinois Geological Survey, p. 151.

pure clay substance in composition. More often, however, it contains numerous grains of unaltered quartz and feldspar. The name kaolin is derived from two Chinese words Kao Ling (lofty hill) from a place where the clay deposits were located. The properties of kaolin are influenced by the nature of the foreign materials present in the mass. To illustrate this effect, let us assume that instead of two parts of silica to one of alumina a kaolin contains 10 parts of silica to one of alumina. This lowers the fusion point of the substance and otherwise changes its properties. The term kaolin is in practice applied only to masses in which the material intermixed is of small quantity. Hence a kaolin represents a pure clay mass.

The composition of a variety of industrial clays may be seen in the following table of analyses, taken from Bull. 9, Illinois Geological Survey:

TABLE 28.—Composition of Clays (Illinois Geological Survey)

| | <i>Silica</i> (SiO_2) | <i>Alumina</i> (Al_2O_3) | <i>Iron Oxide</i> (Fe_2O_3) | <i>Lime</i> (CaO) | <i>Magnesia</i> (MgO) | <i>Alkalies</i> (K_2O and Na_2O) | <i>Water</i> (H_2O) |
|---|------------------------------|---------------------------------|------------------------------------|--------------------------|------------------------------|---|----------------------------|
| | <i>p. ct.</i> | <i>p. ct.</i> | <i>p. ct.</i> | <i>p. ct.</i> | <i>p. ct.</i> | <i>p. ct.</i> | <i>p. ct.</i> |
| China clay (Chinese) | 73.55 | 22.00 | | 2.55 | .55 | | 2.62 |
| China clay (English) | 46.30 | 39.70 | .30 | .40 | | .50 | 12.80 |
| Flint clay | 65.85 | 22.81 | 1.14 | .53 | .37 | 2.01 | 6.93 |
| English fire clay | 65.1 | 22.22 | 1.92 | .80 | | | 9.86 |
| Stoneware clay | 69.35 | 18.08 | 11.25 | .60 | .63 | | 6.59 |
| Paving brick shale ¹ | 62.11 | 17.59 | 4.77 | 1.53 | 2.26 | 3.95 | 7.23 |
| Alluvial brick clay | 69.18 | 15.43 | 5.83 | 2.37 | .71 | 1.98 | 6.85 |
| Glacial brick clay ² | 58.96 | 16.57 | 6.10 | 2.37 | 2.97 | 4.07 | 6.94 |
| Loess brick clay | 13.92 | 11.65 | 4.74 | 1.43 | .60 | 3.13 | 3.08 |

¹ Renton (Washington) Paving Brick.² Seattle (Washington) Common Brick.

RATIONAL ANALYSIS

The foreign materials present, i. e., those insoluble in sulphuric acid and alkali, are classed as quartz and feldspar and represent fragments of the original rocks, or of dehydrated silica of a great degree of fineness. The extent to which these materials may be present is determined by the so-called rational analysis¹ of clays, or it may be computed from an ultimate or complete chemical analysis. For example, we may apply the calculations to the following analysis:

| | | | |
|---|--------|--------|------------------------------------|
| Silica (SiO ₂)..... | 48.00% | } | <i>Essentials 86.00 per cent</i> |
| Alumina (Al ₂ O ₃)..... | 38.00% | | |
| Iron oxide (Fe ₂ O ₃)..... | 0.83% | } | <i>Detrimentials 2.50 per cent</i> |
| Lime (CaO)..... | 0.34% | | |
| Magnesia (MgO)..... | 0.43% | | |
| Alkalies (Na ₂ O and K ₂ O) | 0.90% | | |
| Loss on ignition (H ₂ O).. | | 12.10% | <i>Inert 12.10 per cent</i> |

The percentage composition of feldspar is: K₂O 16.9 per cent, Al₂O₃ 18.44 per cent, and SiO₂ 64.79 per cent; and of clay substance, Al₂O₃ 39.5 per cent, SiO₂ 46.5 per cent, H₂O 14 per cent. If potash is taken as unity in the feldspar, these percentages become respectively, 1, 1.0888, and 3.8284, and if alumina is taken as unity in kaolin, its percentages become respectively, 1, 1.772, and 0.3544. Applying the results of the ultimate analysis of the clay sample, the feldspar in it may be obtained as follows:

| | | | |
|---|---------------|----------|----------|
| Alkalies (taken as K ₂ O) .. | = .9 x 1 | = 0.90 | per cent |
| Alumina (Al ₂ O ₃) | = .9 x 1.0888 | = 0.9797 | " |
| Silica (SiO ₂)..... | = .9 x 3.8284 | = 3.4455 | " |
| Total..... | | 5.3252 | " |

¹ Ries: Clay, Occurrence, Properties and Uses, p. 61.

or, in other words, assuming that all alkalis in clay are combined with silica and alumina in the form of feldspars, 5.32 per cent of the clay consists of feldspar.

The percentage of clay substance may be next computed. Since 0.98 per cent of alumina is combined in feldspar, there remains 38.00 — 0.98, or 37.02 per cent. Hence the percentage of clay substances in the sample is as follows:

| | | | | | |
|---|---|----------------|---|-------|----------|
| Alumina (Al_2O_3) | = | 37.02 x 1.00 | = | 37.02 | per cent |
| Silica (SiO_2) | = | 37.02 x 1.1772 | = | 43.58 | " |
| Water (H_2O) | = | 37.02 x 0.3344 | = | 13.12 | " |
| | | | | 93.72 | " |
| Total | | | | | |

The quartz or uncombined silica is next found, by difference, as follows:

| | | |
|---|-------|----------|
| Silica in clay | 48.00 | per cent |
| Silica in feldspar and clay substance | 47.02 | " |
| | 0.98 | " |
| Free silica | 0.98 | " |

The statement of rational analysis will therefore be as follows:

| | |
|--------------------------|--------|
| Clay substance | 97.72 |
| Quartz | 0.98 |
| Feldspar | 5.32 |
| | 100.02 |

CHEMICAL COMPOSITION

The chemical composition of clay is often an index to its color and fusibility. For the sake of simplicity we may consider the effect which the usual chemical compounds found in clay exert upon kaolin.

Silica in excess of that combined with alumina may be present as quartz particles, minute rock silicates, or de-

hydrated silica. While quartz is highly refractory in itself and at the lower temperatures hinders the fusion of clay, yet at temperatures above 1500° C. it is commonly regarded as a flux lowering the point of fusion of the clay. The effect of the minute rock particles may be illustrated by the action of the feldspar. The potash feldspar fuses at 1300° C. and the soda feldspar at 930° C. At these temperatures, silicate rock particles of this type therefore become active fluxes and lower the fusion point of the material.

Iron is present in nearly all clay masses. Apart from the color which it imparts, it is an active flux.

Calcium is present in clay as carbonate, silicate, or sulphate. If present as a carbonate, it loses its carbon dioxide at 900° C. and becomes an active flux. If caustic lime (CaO) remains uncombined in a burned ware, it is liable to hydrate and expand, causing the ware to crack or blister.

Magnesium may be present as a silicate in mica, where it exerts but little influence on the clay mass, or as dolomitic limestone in which case its general effect is similar to that of lime.

The alkalis are generally present in the form of feldspar as already noted. Their effect is that of active fluxing agents.

Two other compounds are of importance in their effects on clay mass—viz., (1) water and (2) organic matter. Water is present as moisture, which Ries describes as both filling up the pores of the clay and existing as a film around each particle of clay. Chemically combined water enters into the composition of a clay, forming hydrated silicates which give to the clay mass certain specific properties.

Organic matter in clay exerts a far more potent effect upon it than is usually recognized. The work of Acheson¹ in producing the "deflocculated," or colloidal, condition of clay is of more than ordinary interest. In his experiments he treated clays with soluble organic matter, such as tannin

¹ *Trans. Am. Ceram. Soc.*, 6, 31 (1904).

extract, and found that, in the case of a moderately plastic clay, its plasticity was greatly increased, its tensile strength was increased 300 per cent, and that but 60 per cent as much water was required for a given fluidity when tannin was present.

USES OF CLAY

Building Brick.—The clays used in the manufacture of common bricks are widely distributed and vary greatly in composition. The following analyses taken from Ries indicate the variation in composition and physical properties:

TABLE 29.—Composition of Clays Used for Building Brick (Ries)

| | <i>Calcareous clay Wisconsin</i> | <i>Shale Michigan</i> | <i>Brick loam Texas</i> |
|--|--|---------------------------|---------------------------------|
| Silica (SiO ₂).....per cent | 42.28 | 50.50 | 88.71 |
| Alumina (Al ₂ O ₃)..... " | 8.26 | 19.31 | 4.88 |
| Ferric oxide (Fe ₂ O ₃) .. " | 3.84 | 5.89 | 2.00 |
| Lime (CaO)..... " | 13.05 | 1.00 | .30 |
| Magnesia (MgO)..... " | 6.01 | 1.85 | .97 |
| Potash (K ₂ O)..... " | 2.51 | 5.98 | tr. |
| Soda (Na ₂ O)..... " | .49 | | tr. |
| Water (H ₂ O) and carbon dioxide (CO ₂).. " | 22.07 | 9.47 | 2.28 |
| Plasticity..... " | high | good | low |
| Per cent water required " | 18.8 | 32 | 20.9 |
| Average tensile strength " | 316 | 105 | 117 |

The requisites of clays of this kind are that they mould easily and burn at low temperature. To prevent cracking and excessive fire shrinkage, sand is usually mixed with a very plastic clay. For pressed and enameled brick a higher grade clay is necessary. It must give a uniform color in burning, must be free from warping, and should contain no soluble

salts, as these cause an efflorescence or "scum" on the surface of the burned product.

In general the manufacture of bricks consists of four processes, viz., the preparation of clay, moulding, drying, and burning.

The preparation of clay for brick making is conditioned by the physical state of the clay. Hard shales are crushed before grinding while soft shales or tough dry clays are passed direct through the dry pans (Chapter I, Fig. 15). The latter consist of circular pans containing two iron wheels on a horizontal axis. The pans are rotated and the wheels revolving within do the grinding. Disintegrators (Chapter I, Fig. 14), consist of several drums or knives on axles and are so arranged that pairs revolving rapidly in opposite directions form an interlocking system to cut the

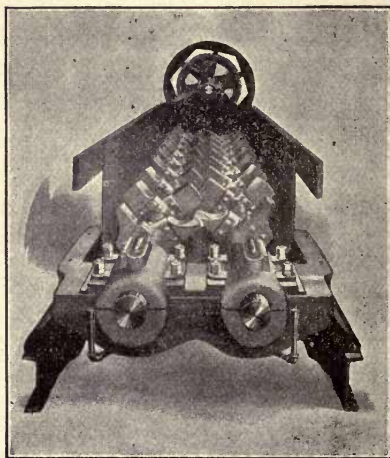

FIG. 43. Pug Mill.

clay into small pieces. Rolls are often used for breaking up pebbles in clay. In some cases the stones in the clay are crushed, in others the rolls are so constructed as to throw out the pebbles.

For wet clays a tempering process is used. The clay is placed in a soak pit, with water, for 24 hours. It is then dug out and fed to the pug mill for kneading. Ring pits are circular pits from 25 to 30 feet in diameter and 3 feet deep, having an iron wheel, which travels around the pit for five

or six hours. Pug mills (Fig. 43) are semi-cylindrical troughs, in which revolves a horizontal shaft with knives set spirally around it. Wet pans, similar to dry pans, are also used for tempering clays.

The moulding of clay is accomplished by one of three processes: soft mud, stiff mud, and the dry press. The soft mud process mixes the clay with water until a soft pasty mass is formed. This is then pressed into wooden moulds, which are sanded each time to prevent the paste from sticking. This process produces a brick of homogenous structure.

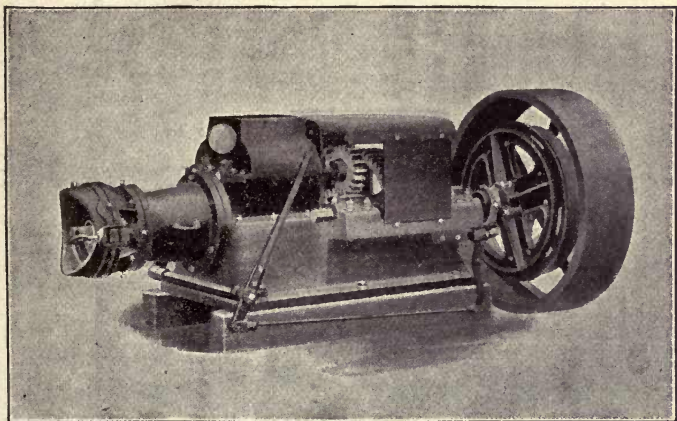

FIG. 44. Brick Auger Machine.

The stiff mud process uses less water in the tempering of the clay. The clay is then forced through a die in the form of a rectangular bar which is subsequently cut into bricks. The auger machine (Fig. 44) which is generally used in this process, is capable of turning out 50,000 bricks in ten hours. Bricks made by this process may be re-pressed and used for face bricks. Clays and shales of moderate plasticity are generally used in the stiff mud process.

The dry press is used for the manufacture of front brick.

The clay is finely ground and pressed in steel moulds by heavy pressure. No subsequent drying is usually required. Bricks made by this process are usually of a granular structure, but possess sharp edges and smooth faces.

The drying of moulded bricks is done in open yards by sunlight, or under covered frames by currents of air, or in drying tunnels where heated air currents from the kilns are used.

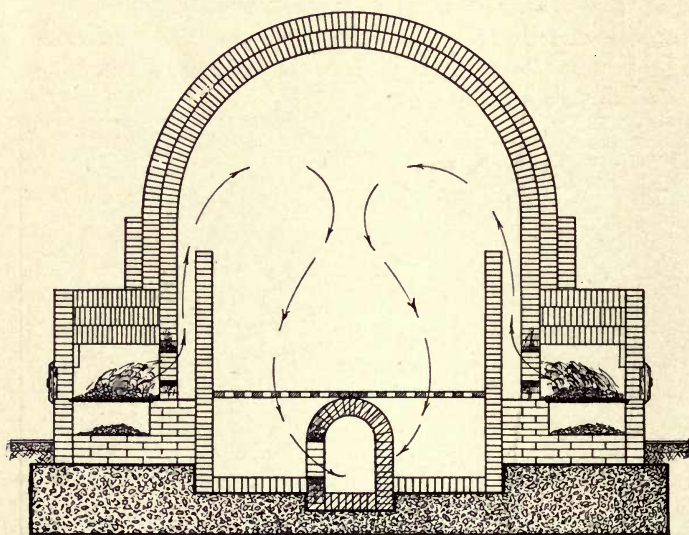

FIG. 45. Down-Draft Brick Kiln.

The burning of bricks is done in kilns usually of one of two types, viz., up-draft or down-draft. In the case of the up-draft type the heat passes up from the fire boxes directly into the body of bricks and escapes from suitable chimneys or openings at the top. In the down-draft system (Fig. 45) the heat from the fire boxes is led through "bags" or flues to the top of the kiln and then downward and carried off from underneath. The latter system is generally preferred, since it gives better control of heat and produces uniform burning.

Control of the fire is effected by either of the following methods:

1. *Settle*. The height of the setting of brick is measured from the crown of the kiln downwards. The distance through which the bricks settle is the point of determination.

2. *Test Pieces*. Fragments of the actual wares are withdrawn as the fire approaches completion. The stage of the burning is judged by inspection.

3. *Seeger Cones*. These are fusible pyramids invented by Herman Seger, the German ceramist. The pyramid bends over when its point of softening is reached. These furnish the most accurate method of control and also afford means of comparison of which other methods are not capable. The work of the cones cannot be strictly expressed in degrees of temperature. The numbers range from .010 which corresponds to the melting point of silver through .04, the melting point of gold, to 25, the melting point of platinum. Common brick are burned from cone .08 to .02; Vitrified brick from .02 to 4; Stoneware, 8; Earthenware biscuit, 7 to 10; Earthenware glaze, 3 to 7; Porcelain biscuit, .06; Porcelain glaze, 13 to 18.

The properties of building brick vary within certain limits which depend upon specific uses. Witness the compact structure of front brick, the slightly over-vitrified surface of clinker brick, and the softer structure of ordinary common brick. In general, however, brick for building should not exceed 20 per cent porosity, should have a minimum compression strength of 2500 pounds per square inch, should possess a uniform color, and should not contain substances that will cause efflorescence of salts, like calcium sulphate, etc., upon the surface of the brick. This efflorescence is a more or less common defect in the case of bricks made from clays high in sulphides, or when the coal used in burning has a high sulphur content. It may be removed¹ by washing

¹ Efflorescence on Brickwork. *Chem. Abs.*, 5, 3329 (1911).

the walls alternately with hard soap (2.2 pounds per gallon) and alum (1 pound per gallon), or, in the case of a calcium sulphate "scum," it may be washed off by a hydrochloric acid solution (1:5). Barium salts added to the clay in proper proportion prevent the formation of efflorescence due to calcium sulphate.

FIRE BRICK

The clay used in the manufacture of fire brick must be capable of withstanding a high degree of heat. No definite standard is recognized but it has been proposed that no clay fusing under 1600° C. should be classed as fire clay.

The composition of a fire clay in general is similar to that of other clays, but the quantities of fluxing materials such as ferric oxide, lime, magnesia, and alkalis must be small. Silica that is not in combination with alumina also lowers the refractoriness. The effect of titanium is similar to that of iron.

The physical properties of fire clays show no direct relation to refractoriness. Color sometimes aids in the selection of a clay, e. g., a white clay is usually refractory, while a reddish or yellowish tinge denotes the presence of iron. Black clays may not be judged in this way, and there are numerous other exceptions. Plasticity and tensile strength are variable factors in refractory clays.

Chemical analysis alone is likewise of little use in judging the refractoriness of clays. On this point a recent writer says: "I have before me the results of two analyses of clays just brought up from the laboratory. These clays are very different in composition, and samples are sent five times each month for both analysis and physical demonstration. The mines are both old ones, and each concern, representing two of the largest rival concerns in the United States, has been in business a great many years, but notice the contrast:

| | No. 1 | No. 2 |
|--|--------|--------|
| Silica (SiO ₂) per cent | 49.44 | 50.50 |
| Alumina (Al ₂ O ₃) " | 34.26 | 24.00 |
| Iron oxide (Fe ₂ O ₃) " | 7.74 | none |
| Carbonate of lime (CaCO ₃) " | 1.48 | 2.70 |
| Carbonate of magnesia (MgCO ₃) " | 1.10 | none |
| Chlorides of the alkalies (KCl and NaCl) " | none | 1.80 |
| Organic matter " | none | 1.01 |
| Moisture, etc. " | 5.98 | 19.99 |
| | 100.00 | 100.00 |

These two clays are in great demand and are very popular, for precisely the same purposes, with those who use them."

The manufacture of fire brick is similar to that of common brick. Usually a mixture of a fairly plastic fire clay and of burned "grog," or chamotte, made from fire clay in proper proportions, is ground up in a dry pan, or disintegrator. It is next screened and tempered in a pug mill, after which it goes into the moulding machines. After drying for a few hours the brick is re-pressed and is then burned in down-draft kilns at a temperature ranging from 1230° C. to 1490° C.

The qualities ¹ of good fire brick should vary with the uses to which they are to be put. To meet the requirements of abrasion they must be hard. Where corrosive action takes place, brick must be dense. In general the refractoriness of a fire brick is dependent upon the total quantity of fluxes present, the silica percentage, and the coarseness of the grain.

PAVING BRICK

The clays suitable for the manufacture of paving brick range from common surface clays to impure refractory clays

¹ Standard specifications for Retort and Firebrick Material. *J. Soc. Chem. Ind.*, 30, 804.

and shales. Paving brick clays are also used for the manufacture of sewer pipes. Surface clays, when burned hard are usually too brittle for use as paving brick. Pure fire clay is not suitable on account of the difficulty and expense of burning and in not yielding a brick of sufficient density, hardness and strength. Shales and clays of similar character are usually employed for the manufacture of paving brick.¹ Their chemical composition is inadequate to define clays suitable for paving brick. The range of composition given by Williams is as follows:²

TABLE 30.—Composition of Clays Used for Paving Brick (Williams)

| | <i>Maximum</i> | <i>Minimum</i> |
|--|----------------|----------------|
| Silica (SiO ₂) per cent | 74.58 | 53.56 |
| Alumina (Al ₂ O ₃) “ | 22.33 | 8.28 |
| Ferric oxide (Fe ₂ O ₃) “ | 5.75 | 2.88 |
| Lime (CaO) “ | 3.42 | 1.55 |
| Magnesia (MgO) “ | 3.47 | 1.22 |
| Potash (K ₂ O) “ | 1.15 | 0.29 |
| Soda (Na ₂ O) “ | 1.79 | 1.08 |
| Water (H ₂ O) “ | 5.33 | 1.73 |
| Carbon dioxide (CO ₂) “ | 2.23 | 1.73 |
| Sulphur trioxide (SO ₃) “ | 2.25 | 1.28 |
| Moisture “ | 1.13 | 0.28 |

The effect of the various constituents upon the properties of paving brick is in general as follows: Silica prevents the shrinkage of clay, and diminishes its plasticity and tensile strength. Iron imparts a red color to the burned product. It is a fluxing agent, and, when united with silica, gives strength to the brick. It causes shrinkage and, in general, is not regarded as a desirable constituent in paving brick, if more than 6 per cent is present. Alumina gives plasticity and

¹ Method of Testing Clays for Paving Brick Purposes. *Trans. Am. Ceram. Soc.*, 12, 265 (1911).

² Iowa Geological Survey, 14, 229 (1904).

adhesiveness to clay and tensile strength to the brick, but causes the clay to shrink and crack in drying. Lime fuses in the presence of excess silica and when small in quantity gives increased strength to the brick. Quicklime is liable to crack the brick if it occurs in nodules. Magnesia acts as a flux and makes the clay soften slowly instead of suddenly, as lime does. Alkalies are the most powerful fluxing materials of clays. In burning they bind the particles together in a dense hard body, lower the proper temperature of burning, and are therefore a very desirable constituent of paving brick clays.

The requisites for paving brick are hardness to resist crushing, toughness to resist abrasive action, homogeneity in texture, freedom from laminations or seams, and imperviousness to water.

Paving bricks are manufactured in the same way as stiff mud bricks. The temperature required ranges from 875° C. to 1150° C.; and in order to increase the toughness of the bricks they are carefully annealed, i. e., the bricks are allowed to cool slowly. If cooled too slowly, however, a crystalline structure is developed which weakens the brick.

TERRA COTTA

In fire proof construction terra cotta affords the most satisfactory means of decorative treatment. The clays used in the manufacture of terra cotta are usually light colored and rather refractory. The ornamental work is moulded and the moulds are made of plaster of paris. In these the prepared clay is pressed. In order to secure sufficient porosity for rapid and safe drying terra cotta clays are mixed with a large proportion of grit or grog made from burned clay. After moulding, the surface of the dry wares is sprayed with a colored slip or hard enamel to secure uniformity.

TILES

The principal kinds of non-decorative tiles are sewer pipe, drain tiles, and partition tiles. Under the latter class are included the hollow blocks, wall blocks, and fireproof material. Clays suitable for the manufacture of sewer pipe are rather refractory in nature because of the necessity for salt glazing which demands a high temperature for the best results. The tile are expressed one by one from a vertical die, being discharged by an intermittent piston stroke. At one end of each tile is a socket so that a cemented joint may be secured. Drain tile, also known as agricultural tile, may be made from almost any plastic clay. They are expressed in a continuous line from an auger machine and are severed into 12 inch lengths by taut wires. The best tile are burned hard enough to resist frost.

For the manufacture of partition tile, the so-called terra cotta clays of low grade are employed. For this purpose clays must have high plasticity and be of uniform texture and composition. They should be even-grained, smooth working, and have good binding power.

Hollow ware in general is considered advantageous on account of lightness, protection against dampness and climatic changes, and fireproofing qualities. The specifications for hollow terra cotta blocks used for partitions require that they be "porous, moulded fair and true, thoroughly and evenly burned, unwarped, free from limestone, magnesia, pebbles, and other defects." The porosity of these blocks is rated at 25 to 40 per cent voids. The strength of the hollow block tested on end is from 3000 to 5000 pounds per square inch.

STONEWARE

The clays used in the manufacture of stoneware must be highly plastic. According to Wheeler¹ they should be:

¹ Missouri Geological Survey, 11, 299; see also *Trans. Am. Ceram. Soc.*, 12, 433 (1911).

“(1) Free from coarse sand; (2) as free from iron as possible; (3) capable of burning to a close, incipiently vitrified body at less than 1300° C.; (4) sufficiently wide in their range of temperature (at least 94° C.) between the points of incipient and complete vitrification; (5) capable of drying and burning at a moderate rate; (6) capable of producing a tough and strong body when burned; (7) free from carbonates, sulphates, and other salts liable to cause blisters in burning.”

The average composition of these clays is given by Ries as follows:¹

| | |
|--|----------------|
| Silica (SiO_2)..... | 61.93 per cent |
| Alumina (Al_2O_3)..... | 21.31 “ |
| Iron (Fe_2O)..... | 2.91 “ |
| Lime (CaO)..... | 1.09 “ |
| Magnesia (MgO)..... | 0.85 “ |
| Alkalies (Na_2O and K_2O)..... | 2.06 “ |
| Loss on ignition..... | 8.56 “ |

Stoneware was formerly glazed by the salt vapor process but this is now used only for chemical stoneware and sewer pipe. Salt glaze is applied by throwing common salt upon the fire after a sufficient heat has been reached. The vaporized salt passes through the kiln, comes in contact with the ware and is evenly deposited upon it forming an insoluble silicate. Chemical stoneware is made from the purer stoneware clays and is calculated to resist the action of acids. Household stoneware is now glazed with the compound known as a Bristol glaze which consists of lime, zinc oxide, feldspar, clay, and quartz. The mixture is ground in water and applied to the raw clay. The wares are burned in an open kiln. “Slip glaze” which is sometimes used on stoneware, especially inside the jars, is a natural clay which fuses at a lower temperature than the body to which it is applied.

¹ Bulletin of New York State Museum, 35, 878-881.

EARTHENWARE

The wide range of wares which may be classed as earthenware includes sanitary wares, kitchen and household utensils, and table dishes. The body of the ware is a composition into which enter kaolin, plastic clay, feldspar and quartz. The mixture is carefully weighed in accordance with an established recipe, fed to a churn-like machine with an excess of water until a creamy fluid is produced. This is strained through fine wire or silk cloth and pumped into a filter press for the removal of the water. The now plastic clay is shaped, dried and burned to the required density. The glaze is subsequently added by dipping and a second burning completes the product. Earthenware glaze contains lead oxide, lime, feldspar, clay, and quartz and sometimes boric acid and soda. The soluble materials are fused into an insoluble glass or fritt which is then ground to a cream with the other constituents of the glaze.

Tin oxide is used in the manufacture of opaque glazes. The coloring of glazes is a matter of some complexity, since it depends on the nature of the glaze (whether silicate, borate, or plumbate); on the temperature of the kiln and its atmosphere (whether oxidizing, neutral, or reducing); and on the reciprocal action that colors have on each other. The following are the more common oxides used with the colors produced:

1. Iron oxide: Brown and red at low temperature, bluish green on reduction, brownish yellow in boracic, and yellow in lead glazes.
2. Copper oxide: Bluish green in oxidizing atmosphere, green in boracic and lead glazes, and purple red in reducing atmosphere.
3. Chromic oxide: Bluish green in alkaline glazes, green in borate glaze. Opaque and muddy in effect.

4. Manganese oxide: Brown to violet; with iron oxide forms a "black."
5. Cobalt oxide: With zinc, ultramarine blue.

PORCELAIN AND CHINA

The various kinds of porcelain ware are classified by Bourry as follows:¹

1. Porcelain for table ware and decoration.
2. Refractory porcelain.
3. Porcelain for electrical insulators.
4. Porcelain for mechanical purposes.
5. Architectural porcelain.
6. Dull porcelain, or biscuit ware.

Porcelain for table ware is either hard or soft. The former is made all over the world but especially in France and Germany. It may be defined as an impermeable, translucent ware, with a white or colored body. It is covered with a glaze which vitrifies at the same time as the burning of the body or biscuit, into a hard surface, which cannot be scratched with steel. The temperature of burning is from 1300° to 1400° C.

Soft porcelain was originally made in France but the manufacture was practically abandoned in favor of the harder ware. Modern soft porcelain is usually called china and is qualified as bone china, hotel china, Belleek china, etc. Bone china is the typical English china and very little is made elsewhere. Its characteristic ingredient is bone ash of which it contains about 40 per cent. Hotel china is a typical American china. It owes its translucency to a high content of feldspar and a severe fire. Belleek china is an importation from Ireland, whence the name. It has been imitated successfully by American potters.

Refractory porcelain is used in the manufacture of crucibles,

¹ Treatise on Ceramic Industries, 2d revised edition, page 431 (1911).

evaporating dishes, and wares exposed to fire. Its composition differs from that of other porcelains, being in general more aluminous and less silicious. Its main property is its resistance to sudden change of temperature. Electrical insulators are now largely made of porcelain. For this purpose no translucency is required, but high plasticity is necessary to allow moulding of the complicated shapes. Porcelain for mechanical purposes, as in mortars and ball mills, requires hardness and strength. When porcelain is without glaze, its surface is dull and it goes under the name of biscuit ware.

All these wares, except bone china, consist essentially of clay substance, feldspar, and quartz. The mixture is prepared as described under earthenware but variations in proportion are introduced and more or less care exercised in the selection and manipulation according to the standard of quality. An important point in the manufacture of hard porcelain, whether for household, electrical, or chemical use, is that the body and glaze are brought to maturity at the same time and temperature. This necessitates a very infusible glaze containing only lime, feldspar, clay, and quartz. The china glazes are akin to those used for earthenware. They are matured at a second and less severe fire, the biscuit ware having been previously vitrified.

REFERENCES

I

- BINNS: Ceramic Technology.
BLEININGER: The Effect of Heat Upon Clays.
BOURRY: Treatise on Ceramic Industries.
BRANNER: Bibliography of Clays and the Ceramic Arts.
BURTON: Porcelain.
HAVARD: Refractories and Furnaces.
HECHT AND CRAMER: The Collected Writings of Herman Seger.
JACKSON: Text Book of Ceramic Calculations.

- KANOLT: Melting Points of Fire Bricks. Tech. Paper No. 10, U. S. Bureau of Standards (1912).
- RIES: Clays, Occurrence, Properties and Uses.
- RIES: Clay Working Industries.
- ROLFE: Paving Brick and Paving Bricks of Illinois.
- SEARLE: Clay Workers Handbook.
- SEXTON: Fuel and Refractory Materials.
- SHEDD: Clays and Clay Products of Washington.
- WHEELER: Vitrified Paving Brick.

II

- PURDY AND MOORE: Pyro-Chemical and Physical Behavior of Clays. University of Illinois, School of Ceramics, Bull. 3 (1907).
- The Fire Resisting Properties of Various Building Materials. U. S. Geol. Survey, Bull. 370 (1907).
- ASHLEY: The Colloidal Matter of Clay. U. S. Geol. Survey, Bull. 388 (1909).
- HOWARD: Strength and Absorption of Brick. *Eng. News*, 61, 273 (1909).
- ASHLEY: The Manufacture of Crucibles, Scorifiers, and Muffles. *Trans. Am. Cer. Soc.*, 12, 54 (1910).
- ASHLEY: Requirements of Pottery Material. *Trans. Am. Ceram. Soc.*, 12, 433 (1910).
- GREAVES-WALKER: Efflorescence on Brick Work. *J. Ind. Eng. Chem.*, 2, 373 (1910).
- GRÜNHUT: Drying Plants for Clay and Clay Products. *Trans. English Ceram. Soc.*, 9, 227 (1910).
- MELLOR: Nomenclature of Clays. *Trans. English Ceram. Soc.*, 9, 114 (1910).
- PAGE: Report of Committee C-3, on Standard Specifications for Paving and Building Brick. *Am. Soc. Test. Mat.*, 10, 96 (1910).
- SEAVER: Refractory Materials. *Proc. Eng. Soc. Western Pa.*, Apr., 1910.
- ASHLEY: The Decomposition of Clays by Smelter Smoke. *J. Ind. Eng. Chem.*, 3, 91 (1911).
- CLARKSON: Some Electrical Tests of Porcelain. *Elect. World*, 57, 1222 (1911).
- CRAMER: Compression Tests of Fire Brick. *Tonind. Ztg.*, 35, 452 (1911); *Chem. Abs.*, 5, 1981.
- DOUTY AND BEEBE: Determination of Specific Absorption and Permeability of Brick. *Eng. News*, 66, 233 (1911).

- MEHLHORN: Down-Draft Kilns for Fire Brick Industry. *Tonind. Ztg.*, **35**, 454 (1911); *Chem. Abs.*, **5**, 1982.
- MELLOR: The Action of Heat on Fire Clays. *Iron Coal Trades Rev.*, **82**, 1045 (1911); *Chem. Abs.*, **5**, 3139.
- MARSTON AND ANDERSON: Standard Tests for Drain Tile and Sewer Pipe. *Eng. News*, **65**, 258 (1911).
- REMINGTON: Paper Makers' Clay. *J. Ind. Eng. Chem.*, **3**, 550 (1911).
- SAUNDERS: Alundum as a Refractory. *Met. Chem. Eng.*, **9**, 257 (1911).
- STALEY: The Calculations of Ceramic Mixtures. *Trans. Am. Ceram. Soc.*, **13**, 122 (1911).
- New Standard Rattler for Testing Paving Brick. *Eng. Contr.*, **45**, 554 (1911).
- BROWN: A Method of Testing Clays for Brick Purposes. *Trans. Am. Ceram. Soc.*, **12**, 265 (1912).
- FITZGERALD: Refractories. *Met. Chem. Eng.*, **10**, 129 (1912).

CHAPTER XII

HYDRAULIC CEMENTS AND LIME PRODUCTS

AMONG the materials used for structural purposes cements and lime products occupy an important place. The specific function of these products is to furnish a binding or bonding agency for structural materials of larger bulk. For example, a mixture of sand and lime paste (mortar) was early found capable of holding in place stone and other mineral aggregates of large dimensions. When the sand consisted of finely crushed volcanic rock, such as the tufas or volcanic ash used in constructive work by the Romans, it was found furthermore that the resulting product became unusually hard even in the presence of water. This property, viz., the ability to set and harden while in contact with water, is what gives rise to the name *hydraulic cement*. A lime mortar on the other hand requires the action of the carbon dioxide of the air for ultimate hardening, as represented by the reaction, $\text{Ca}(\text{OH})_2 + \text{H}_2\text{CO}_3 \rightarrow \text{CaCO}_3 + 2\text{H}_2\text{O}$, the crystallization of the calcium carbonate upon the surface and interstitial spaces being largely responsible for the hardness and continuity of a lime mortar. As shown later, the chemical actions which take place in hydraulic compounds represent the breaking down of the compound and, generally, its subsequent hydration.

The following classification of these structural materials is proposed:

I. Hydraulic Cements.

1. Portland cement.
2. Natural cement.
3. Puzzolan cement.

- a. Slag cement from artificial puzzolan.
- b. Puzzolan proper from natural puzzolan.

II. Lime and Gypsum Products.

1. Hydrated lime.
2. Sand lime brick.
3. Stucco and plasters.

I. HYDRAULIC CEMENTS

The hydraulic cements have come into extensive use during recent years as binding agents in mortars composed generally of sand and cement; in concrete consisting of sand, crushed rock or gravel, and cement; in various mixtures applied to wall surfaces and known as plasters, stucco, etc.; and in the construction of blocks and artificial stone: ¹

PORTLAND CEMENT

The extensive use made of Portland cement is evident from the census returns of 1910 which showed 108 plants in operation, producing annually about 65,000,000 barrels of cement with a corresponding valuation of approximately \$53,000,000. A later estimate gives 80,000,000 barrels worth about \$64,000,000.

The essential constituents of Portland cement are silica, alumina and lime. Other substances are usually present and exert an influence on the quality or use of the cement. The limits to which these substances may be present have been set by American practice as follows: ²

| | | |
|--|--------|----------|
| Silica (SiO ₂)..... | 19-26 | per cent |
| Alumina (Al ₂ O ₃)..... | 4-11 | " |
| Iron oxide (Fe ₂ O ₃)..... | 0-4 | " |
| Lime (CaO)..... | 58-67 | " |
| Magnesia (MgO)..... | 0-4 | " |
| Sulphuric acid (SO ₃)..... | 0-1.75 | " |
| Alkalies (Na ₂ O and K ₂ O)..... | 0-3 | " |

¹ For a fuller discussion of the uses of hydraulic cements the student is referred to Bulletin 2 (Fourth Series), Ohio Geological Survey (1904); and to the references cited at the end of the chapter.

² Bulletin No. 3, Fourth Series, Ohio Geological Survey.

The materials most commonly used for the preparation of Portland cement are clay and limestone, ground together and then heated. In the specifications adopted by the Society for Testing Materials the term Portland cement "is applied to the finely pulverized product resulting from the calcination to incipient fusion of an intimate mixture of properly proportioned argillaceous and calcareous materials, and to which no addition greater than 3 per cent. has been made subsequent to calcination." These specifications also provide that the cement shall not contain more than 1.75 per cent. of SO_3 nor more than 4 per cent. of MgO .

Raw Materials.—Portland cement in the United States is made from six classes of raw materials: (1) *Cement rock and limestone*, as in the case of the Lehigh cements. Cement rock is an argillaceous limestone with an average composition of 74 per cent calcium carbonate and the rest clay material, such as silicates of aluminum and iron. Usually some quantity of pure limestone is added, though in some industries the admixture of rocks from different strata is sufficient. The distinguishing characteristic of "cement rock" is its nearly ideal content of calcium carbonate mixed with the correct proportion of clay material. (2) *Limestone and clay mixtures* are used in the majority of plants.¹ The clay contains about 55 per cent silica and from 18 to 25 per cent alumina. The limestone should be as nearly pure as possible. (3) *Marl and clay* are used in the central west. Marl, as termed in the cement industry, is an amorphous calcium carbonate, containing much water, often up to 50 per cent, and much organic matter. It is of fresh water origin. About 25 per cent to 30 per cent clay is added. (4) *Chalk and clay* are used extensively in Europe, and in South Dakota, Texas, and Arkansas. (5) *Slag and limestone* are used for the manufacture of true Portland cement by the Illinois Steel Company. (6) *Alkali*

¹ For description of material and plants see *Pacific Builder and Engineer*, 7, 68 (1909).

waste (from the ammonia soda process) and clay are employed in Michigan.

The following examples will illustrate cements made from these six types of material:

Mixture 1. Cement rock and limestone, Lehigh County, Pa. (U. S. Geol. Sur., Bul. 243).

“ 2. Limestone and clay, Baker, Washington (Superior Portland Cement Co.).

“ 3. Marl and clay, New York State (U. S. Geol. Sur. Bul. 243).

“ 4. Chalk and clay, Dakota (U. S. Geol. Sur., Bul. 243).

“ 5. Slag and limestone, Illinois Steel Co. [Taylor's Cement Testing, p. 17 (1906)].

“ 6. Alkali waste and clay, Michigan [*Eng. News*, 43, 372 (1900)].

The following tables show the composition of the various raw materials and the resulting cement:

TABLE 31.—Analyses of Raw Materials for Cement Manufacture

| Mixture | Silica (SiO ₂) | Alumina (Al ₂ O ₃) | Iron (Fe ₂ O ₃) | Lime (CaO) | Magnesia (MgO) | Sulphuric Acid (SO ₃) | Carbonic acid (CO ₂) | Alkalies (K ₂ O + Na ₂ O) |
|--------------------------|-------------------------------|--|---|---------------|-------------------|--------------------------------------|-------------------------------------|--|
| | p. ct. | p. ct. | p. ct. | p. ct. | p. ct. | p. ct. | p. ct. | p. ct. |
| (1) Cement Rock . . . | 19.06 | 4.44 | 1.14 | 38.78 | 2.01 | | 32.66 | |
| Limestone | 1.98 | 0.42 | 0.28 | 53.31 | 0.97 | | 42.94 | |
| (2) Limestone | 2.26 | 0.84 | | 53.63 | 0.80 | 0.14 | 42.14 | 2.50 |
| Clay | 57.08 | 18.82 | 6.02 | 1.19 | 2.24 | | | |
| (3) Marl | 0.26 | 0.21 | 0.01 | 50.98 | 0.19 | | 40.26 | |
| Clay | 42.85 | 13.51 | 4.49 | 12.69 | 3.30 | | 13.59 | |
| (4) Chalk | 4.14 | 1.81 | 2.72 | 51.00 | 0.10 | 0.50 | 37.99 | |
| Clay | 61.53 | 20.74 | 4.01 | 5.28 | 1.72 | 1.26 | 3.09 | |
| (5) Slag | 35.60 | 12.56 | | 48.09 | 1.75 | | | |
| Limestone | 2.00 | 1.50 | | 53.20 | 1.50 | | 41.80 | |
| (6) Alkali waste | 0.98 | 1.62 | | 50.40 | 4.97 | | | 0.50 |
| Clay | 46.81 | 14.21 | | 14.04 | 3.61 | 1.18 | .11 | 3.04 |

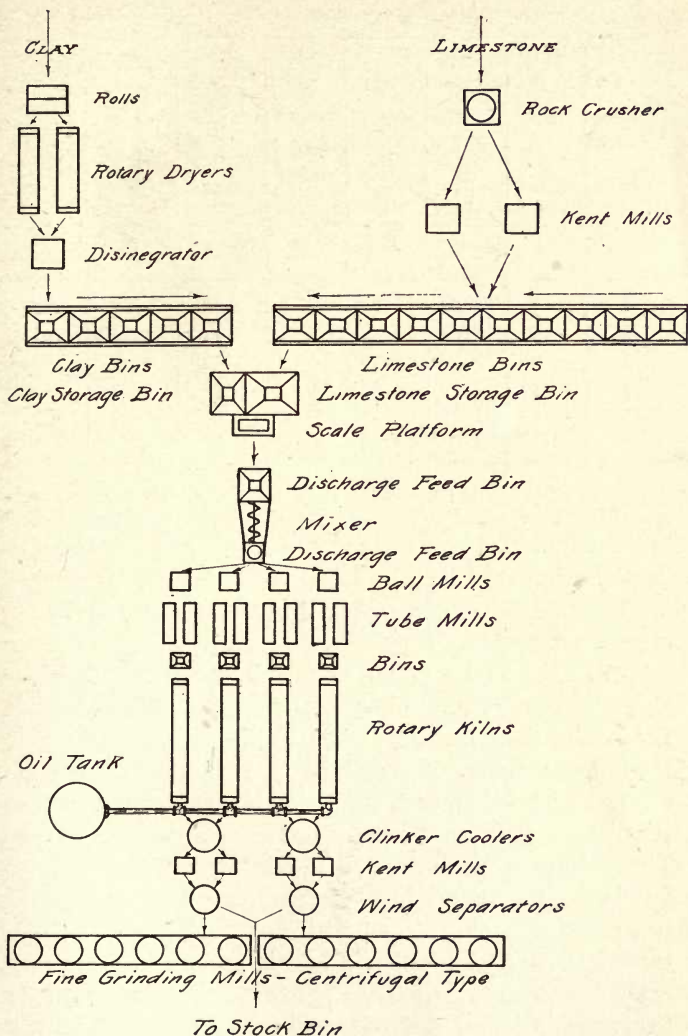

FIG. 46. Steps in the Process of Portland Cement Manufacture.

TABLE 32.—Analyses of Cements from Various Mixtures

| <i>Mixture</i> | <i>Silica</i> (SiO_2) | <i>Alumina</i> (Al_2O_3) | <i>Iron</i> (Fe_2O_3) | <i>Lime</i> (CaO) | <i>Magnesia</i> (MgO) | <i>Sulphuric acid</i> (SO_3) | <i>Alkalies</i> (K_2O and Na_2O) |
|----------------|----------------------------------|--|---|------------------------------|----------------------------------|--|---|
| | <i>p. ct.</i> | <i>p. ct.</i> | <i>p. ct.</i> | <i>p. ct.</i> | <i>p. ct.</i> | <i>p. ct.</i> | <i>p. ct.</i> |
| 1 | 21.30 | 7.65 | 2.85 | 20.95 | 2.95 | 1.81 | 1.15 |
| 2 | 23.06 | 5.59 | 2.65 | 60.74 | 2.21 | 1.38 | |
| 3 | 21.98 | 8.20 | 3.70 | 61.83 | 1.43 | 1.18 | 0.84 |
| 4 | 19.50 | 7.70 | 4.30 | 60.00 | 0.80 | 2.80 | 1.20 |
| 5 | 21.40 | 7.15 | 2.25 | 62.42 | 2.09 | 1.50 | |
| 6 | 23.20 | 8.00 | 2.40 | 62.10 | 2.00 | | |

Manufacturing Processes.—There are three main stages in the manufacture of Portland cement: (1) grinding and mixing the raw materials; (2) calcination of mixture; (3) grinding of clinker. The accompanying diagram (Fig. 46) shows the sequence of steps in the process.

The mixing and grinding of raw materials may be done either by the dry method or by the wet method. About 80 per cent of the cement manufactured in America is made in the former manner. The rock is first crushed to a maximum size of 2 inches diameter, stored in bins, analyzed, and then mixed with other rock or clay to the necessary proportion. The mixture is then conveyed to a rotary cylinder 40 to 50 feet in length, slightly inclined from horizontal, and heated to a sufficient temperature to drive out moisture. The mixture then goes to a ball mill and is ground so as to pass through a 30 mesh sieve. After grinding, the mixture goes to the tube mill (q. v.), or Griffin mill (q. v.) where it is ground so that 90 per cent will pass through a 100 mesh sieve. The fine powder is next conveyed to the rotary kiln (Fig. 47) and

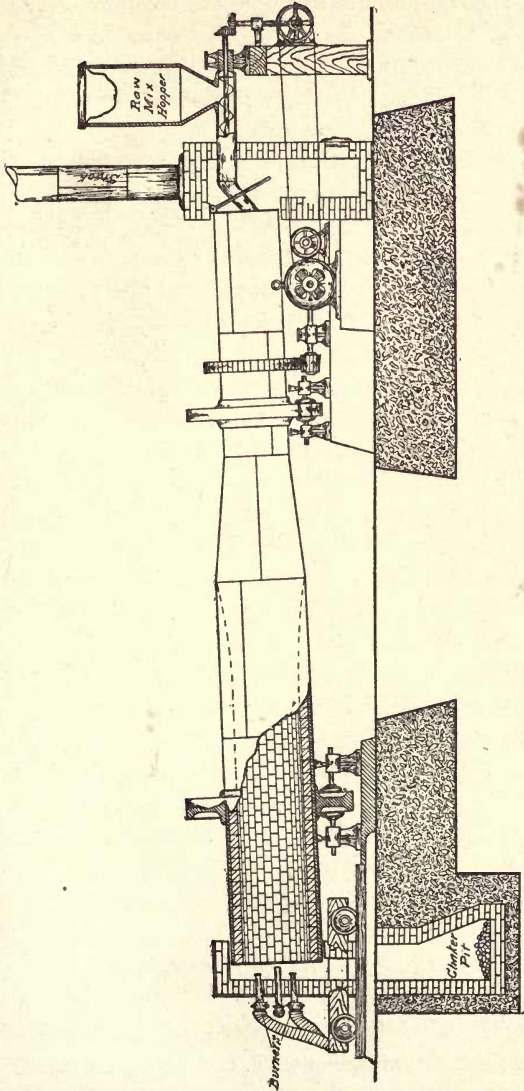

FIG. 47. Rotary Kiln Used in the Manufacture of Portland Cement.

calcined, leaving the kiln usually in small lumps. The calcined material called "clinker" is then sprayed with a small stream of water or cooled by air blast. The final stage is the grinding of the clinker into fine powder by combinations of grinding machines of various types.

Mills producing cement from marl and clay generally make use of the wet or semi-wet process. In this case the mixture is made by adding water to the finely ground materials and agitating the mixture in mechanical mixers or pugging machines, after which the raw material is fed into the upper end of the rotary kilns. These are longer than the kilns used in the dry method, and require about 50 per cent more fuel. The grinding of the clinker is the same as in the dry method.

The manufacture of Portland cement from blast furnace slag¹ is slightly different. In the United States the slag on leaving the blast furnace is sprayed with water, which suddenly cools it, disintegrates it into granules, and also drives off a portion of the sulphur as hydrogen sulphide. The granulated slag is then dried, ground, mixed with limestone, and converted into Portland cement by the dry method. In Germany the method² of Dr. Passow (Patent 1901) is said to yield Portland cement. In this process air is blown through liquid slag, and the oxidized slag is then ground to the fineness of Portland cement and used as a substitute for, or adulterant of, Portland cement. Obviously a slag of very uniform and somewhat limited composition must be used.

Physical Properties of Portland Cement.—Portland cement is a fine powder, 92 per cent of which passes through a 100 mesh sieve and 75 per cent through 200 mesh. *Fineness* exerts an important influence on its value, the coarser particles being generally inert, while the finer cements enable the use of more sand in mixture.

The *hardening* of cement is considered to take place in two

¹ For description of process see *Eng. News*, 66, 213 (1910).

² *Iron Coal Trades Rev.*, 66, 1271 (1903).

steps: (1) setting and (2) hardening. The first may require from 15 minutes to 12 hours, while the last extends from seven days to months and, in some cases, years. The time of setting and hardening determines largely its commercial value. It may be ascertained by laboratory tests with the Gilmore and Vicat needle according to uniform and prescribed methods.¹ Physical conditions exert a marked influence upon the property of setting and hardening. The presence of too much water in mixing retards the setting. The temperature of the water used also has a modifying effect. Cold water retards, while warm water hastens, the setting and also increases the ultimate hardness. A finer cement sets more rapidly than a coarse one. An old cement sets more slowly than a fresh one. The presence of adulterants or of certain salts in the water exerts an influence; hard water and sea water retard, while alkalis accelerate the setting.

The *tensile strength* of cement is usually determined rather than its compression, although the latter in reality represents the strain to which it is more commonly subjected in actual use. The compression strength is usually assumed to be 10 times the tensile strength. The tensile strength of neat (i. e., without sand) cement ranges from 600-1000 pounds at the end of three months. Fine cements have greater strength than the coarsely ground cements. Chemical composition and quantity of water used also affect the strength of cement.

The *constancy of volume* or the permanence of the changes which take place in cement is an important factor. The temperature coefficient of expansion is .0000055, or nearly the same as that of iron (.0000066); while the coefficient of linear expansion due to hydration is .0123 per cent after seven days. Irregular changes often take place, due to abnormal conditions. These may often be determined in an accelerated

¹ See standard methods for cement testing in Report of the Committee of the American Society of Civil Engineers on Uniform Tests of Cement, June (1903 and 1904).

laboratory test in which a cement pat is boiled for three to six hours and its conditions noted. The disintegration may be due to a number of causes, such as insufficient storage, underburning, coarse raw or clinker grinding, improper mixing and presence of impurities.

Portland cement has a *specific gravity* of 3.10 to 3.25. These limits are in a measure useful in determining the presence of adulterants. The usual and permissible impurities of Portland cement, namely, water, carbon dioxide and gypsum, however, exert a far greater effect on the specific gravity of the cement than adulterants of the former kind. The specific gravity of some adulterants is shown by the following:

| | |
|-------------------------|--------------|
| Hydraulic lime. | sp. gr. 2.52 |
| Slag. | " 3.01 |
| Coal. | " 1.39 |
| Gypsum. | " 2.33 |
| Natural cement. | " 2.60 |
| Coal cinder. | " 2.73 |

SUMMARY OF PHYSICAL PROPERTIES ¹

| | |
|--|---|
| Specific gravity. | not less than 3.10 |
| Loss on ignition. | not more than 4 per cent |
| Fineness. | { 92% must pass 100 mesh { 75% must pass 200 mesh |
| | |
| Setting. | { Final in not less than 1 hr. { nor more than 10 hrs. |
| | |
| Tensile strength (neat) in 24 hours in moist air | 175 lbs. |
| | in 7 days (6 days in water) . . 500 lbs. |
| | in 28 " (27 " " ") . 500 lbs. |
| Tensile strength (one part cement and three parts sand): | |
| 7 days (6 days in water) | 200 lbs. |
| 28 " (27 " " ") | 275 lbs. |
| Constancy of volume: shall not check, crack or disintegrate. | |

¹ See United States Government Specifications for Portland Cement, Bureau of Standards, Cir. 33.

The Chemical Properties of Portland Cement.—The method used in manufacturing Portland cement shows that it is a fused compound somewhat analogous to a slag. It approximates the basic rocks belonging to the peridotite groups, familiar examples of which are the pyroxenes and hornblende.

Its mineral composition based on a Lehigh cement (q. v.) is approximately as follows:

1.1 CaO, 0.35 SiO₂, 0.075 Al₂O₃, 0.018 Fe₂O₃

If alumina is taken as unity the composition becomes 14.6 CaO, 4.6 SiO₂, 1Al₂O₃, 0.24 Fe₂O₃, in which it is seen that the percentage of silica is much greater than in the clay base, Al₂O₃, 2SiO₂, 2H₂O, known as kaolinite.

No final conclusions in regard to the constituents of cement powder and the consequent reactions when water is added have yet been reached. The pioneer investigator of the constitution of Portland cement is Le Chatelier,¹ who made a microscopical examination of both fresh and hardened cements. He distinguished two main constituents called alite and celite. The former has the composition of 3CaO·SiO₂ and exists in the form of double-refracting, colorless, cubical crystals. Celite is a darker, double-refracting, non-crystalline substance. Le Chatelier also found opaque crystals of a yellowish color and striated structure called belite, and some very small double-refracting crystals called felite. He was unable from this study to work out the nature of the crystallized compounds but considered Portland cement as composed of tricalcium silicate with varying amounts of calcium aluminate, ferrate, and lower silicates.

When water is added to Portland cement two reactions were observed: (1) the formation of crystals of hydrated lime, and (2) the swelling of the darker compounds, sup-

¹ Experimental Study on Constitution of Hydraulic Mortars—a thesis for Doctor's degree. Annales des Mines (1887).

posedly the aluminates. According to this research, the reactions that take place in the setting and hardening of cement are:

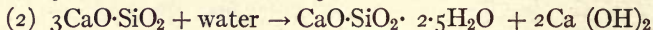
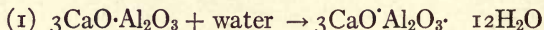

The latter equation seems to be sustained by a petrographical study made by Liamin,¹ who mechanically separated the calcium hydroxide crystals and found that the percentage of calcium hydroxide increased from 3.2 per cent after seven days to 32 per cent after a year.

The investigations of Clifford Richardson² in 1902-04 tend to show that Portland cement consists of two solid solutions: viz., (1) tricalcium aluminate in tricalcium silicate, and (2) dicalcium aluminate in dicalcium silicate.

The preparation of synthetic compounds of a hydraulic nature led S. B. and W. B. Newberry³ to conclude that the essential constituents of Portland cement are tricalcium silicate and dicalcium aluminate, the composition being expressed by the formula $x(3\text{CaO}\cdot\text{SiO}_2) + y(2\text{CaO}\cdot\text{Al}_2\text{O}_3)$. On the basis of this formula a ratio known as the index of cementation has been proposed as follows:

Cementation index =

$$\frac{(2.8 \times \% \text{SiO}_2) + (1.1 \times \% \text{Al}_2\text{O}_3) + (0.7 \times \% \text{Fe}_2\text{O}_3)}{\% \text{CaO} + (1.4 \times \% \text{MgO})}$$

This value should lie between 1.0 and 1.2, a result lower than 1.0 being a sure indication of free lime. For a rough approximation of the amount of lime required in a given mixture, magnesia and iron oxide are regarded as interchangeable with lime and alumina respectively, and the formula becomes $\% \text{CaO} = 2.8 \% \text{SiO}_2 + 1.1 \% \text{Al}_2\text{O}_3$.

¹ Report of Imperial Russian Technical Society, 1897.

² Address before Association of Portland Cement Mfrs., June 15, 1904.

³ Studies on the Constitution of Hydraulic Cements, published by *Cement and Engineering News* (1902).

The recent work of Keisermann¹ makes use of various stains to identify the constituents of Portland cement. By this method he shows that the clinker is a conglomerate of dicalcium silicate and tricalcium aluminate in the proportions of $4(2\text{CaO}\cdot\text{SiO}_2) + 3\text{CaO}\cdot\text{Al}_2\text{O}_3$. In the hardened cement he found fine needle-like crystals of hydrated monosilicate of calcium, $\text{CaO}\cdot\text{SiO}_2$, and a colloidal mass of the same compound, its colloidal condition being supposedly due to a larger percentage of water than in the former case. He concludes that the tricalcium aluminate does not contribute anything to the setting and hardening of cement.

The colloidal theory of the hardening of hydraulic materials advocated by W. Michaelis, Sr.,² has recently attracted considerable attention. According to this view, the hydraulic properties of cements depend upon the formation of solid colloids, which, unlike liquid colloids, have walls that are impervious to liquids. Thus whenever free silica, or silica partly uncombined (as in slags), comes in contact with water and lime, or when water acts upon silicates over-saturated with lime (as in Portland cement) colloidal calcium hydro silicate is formed. This theory has found practical application in the manufacture of the artificial sandstones and sand lime products described later. In cement mortars therefore the hydro silicate forms a glue, covering the sand particles, which on drying becomes hard and is not again softened by water. It is this hydro silicate which in reinforced concrete covers the steel like varnish and protects it from oxidation.

Aside from this mass of contending opinions, we can form a mechanical conception of the nature of Portland cement from its method of manufacture, which may be considered in a number of steps.

¹ Keisermann: *Der Portlandzement*, published by Steinkopff, Dresden.

² The Hardening Process of Hydraulic Cements, published by *Cement Eng. News* (1907).

1. Raw materials are calcium carbonate, clay, quartz, feldspar, mica, hornblende, etc.

2. This mixture at 850° – 900° C. gives off carbon dioxide and the chemically combined water. The clay substance, $\text{Al}_2\text{O}_3 \cdot 2\text{SiO}_2 \cdot 2\text{H}_2\text{O}$, now becomes $\text{Al}_2\text{O}_3 \cdot 2\text{SiO}_2 \cdot 2\text{CaO}$.

3. At 1000° C. lime combines with free silica, forming a porous mass. As the temperature increases, the fluxes enter into combination forming a solidified mass. This stage between 1000° and 1100° C. represents the formation of lower silicates.

4. With increase of temperature up to 1450°C ., the fusion process goes on, more and more lime going into solution until finally in cooling a basic silicate crystallizes out. The latter is the cement clinker—an unstable compound which is both hydrolyzed and hydrated by water, forming stable and permanent compounds of great hardness and strength.

Certain significant properties are ascribed to the various constituents entering into the manufacture of Portland cement. These will be described briefly.

Lime constitutes about 60 per cent of cement. It should all be in the combined form, otherwise hydration (slaking) of lime will occur, causing the expansion and disintegration of the cement. The greater the amount of combined lime in a cement, in general the greater the strength of the cement. High lime cements require a greater heat in burning and are slow setting.

Silica exists in the combined state in Portland cement to the extent of about 20 per cent. Highly silicious cements are slow in setting, and have low tensile strength, at first, due to slowness of hydration.

Alumina is present in cement to the extent of from 5 to 10 per cent. It is usually combined with calcium, and is an active agent in the setting properties of cement. The greater the quantity of combined alumina, the quicker setting will be the cement. Large quantities of alumina, however, re-

duce the tensile strength and also render the cement more easily overburned, since the aluminous compounds are much more fusible than the silicates of lime.

Iron oxide is present in small quantities, usually less than 4 per cent. Its hydraulic properties in cement are similar to those of alumina. It exerts no influence on the physical properties except being the cause of the dark gray color of the cement.

Magnesia is usually looked upon as harmful if present in quantity greater than 4 per cent. Its exact influence has not yet been determined. According to A. E. Carey, magnesia causes disintegration by expansion due to the formation of magnesium hydroxide, which washes out and leaves the cement honeycombed. If magnesia remains free, then its presence acts merely as an adulterant. Standard specifications in America limit the amount of magnesia to 4 per cent; in Germany 5 per cent is the limit.

Sulphuric acid existing as sulphate is a constituent of cement. It originates from two causes. Calcium sulphate is added to finished cement in order to regulate the setting of cement. The effect is obvious from the following table from Chandlot:

TABLE 33.—Influence of Calcium Sulphate upon Setting of Cement (Chandlot)

| Quantity of gypsum added | Initial set | | Hard set | |
|-----------------------------|-------------|---------|----------|---------|
| | Hours | Minutes | Hours | Minutes |
| 0.0 | 0 | 7 | 0 | 22 |
| 0.5 | 0 | 50 | 2 | 43 |
| 1.0 | 2 | 40 | 4 | 50 |
| 1.5 | 2 | 57 | 5 | 17 |
| 2.0 | 3 | 00 | 5 | 20 |
| 3.0 | 3 | 00 | 6 | 40 |
| 4.0 | 3 | 30 | 7 | 0 |

Sulphates may also be formed from the oxidation of the sulphur in fuels and may be present in the raw materials. From whatever source, the amount present is limited by the specifications to 1.5 to 2 per cent. If the sulphates are reduced in burning, sulphides may be formed. This causes the cement to become mottled with dark blue spots in hardening and, if oxidation follows, the cement is apt to disintegrate from the subsequent expansion.

Sulphates in sea water are responsible for the rapid disintegration of cement in salt water, the action according to Chandlot being due to the formation of calcium sulpho aluminate, $3\text{CaOAl}_2\text{O}_3 + 3\text{CaSO}_4$. This compound on crystallizing takes up about 30 molecules of water, producing great increase of volume and destroying the cohesion of the mortar or cement. It has been found that the substitution of iron oxide for alumina produces satisfactory results in sea water usage. Such a cement, made in Germany from silicious limestone and iron ore, goes under the name of ore cement.

Alkalies vary in amount from 5 to 2 per cent in Portland cement. They seem to have little influence on the properties of cement.

NATURAL CEMENT

Natural cement is made from the burning and subsequent grinding of an argillaceous limestone. The method of manufacture omits previous pulverization and mixing, and the heat of burning is not raised to the clinkering temperature.

The use of natural cement in the United States is steadily decreasing, being replaced by Portland cement. The total amount produced in the United States in 1909 was 1,537,638 barrels which were valued at \$652,756. The two leading natural cement districts are the "Rosendale" in New York and the "Louisville" in Indiana and Kentucky.

The manufacture of natural cement is very much simpler than in the case of Portland cement. The raw stone is

quarried and conveyed to burning kilns. These are plain, vertical, cylindrical kilns made of stone, brick, or iron, lined with fire brick and operating continuously. They are about 36 feet in height and 12 feet in diameter, tapering at the bottom to a reduced section. Bituminous or anthracite coals are used as fuels. The rock and fuel are fed in alternate layers into the top of the kiln in the proportion of about 8 parts rock to 1 part fuel. The temperature of the kilns is from 700° to 1000° C. The burned material is next crushed and ground and packed in barrels.

The composition of natural cement is hardly ever uniform, owing to the differences of composition in the strata of a quarry. The content of silica, magnesia, alkalies, and carbonic acid is higher and that of lime is lower than in Portland cement. The burning is hard to control and portions are liable to be overburned or underburned. The composition of the compounds resulting from the burning also differ from the Portland cement, as may be noted in Table 34.

TABLE 34.—Analyses of Natural Cements (From Eckels "Cement Materials and Industry")

| | <i>Louisville</i> | <i>Rosendale</i> |
|---|-------------------|------------------|
| Silica (SiO ₂) per cent | 26.40 | 27.30 |
| Alumina (Al ₂ O ₃) " | 6.28 | 7.14 |
| Iron oxide (Fe ₂ O ₃) " | 1.00 | 1.80 |
| Lime (CaO) " | 45.22 | 35.98 |
| Magnesia (MgO) " | 9.00 | 18.00 |
| Alkalies (K ₂ O and Na ₂ O) " | 4.00 | 6.80 |
| Loss on ignition " | 7.86 | 2.98 |

SPECIFICATIONS FOR CEMENT

Detailed specifications for both natural cement and Portland cement were recently adopted by the American Society for Testing Materials. While some of the points covered in

these specifications have already been discussed in the foregoing text, it seems best in view of the importance of the matter to reproduce the specifications here in full.

AMERICAN SOCIETY FOR TESTING MATERIALS
PHILADELPHIA, PA., U. S. A.
AFFILIATED WITH THE
INTERNATIONAL ASSOCIATION FOR TESTING MATERIALS

STANDARD SPECIFICATIONS FOR CEMENT¹

Adopted August 16, 1909

GENERAL OBSERVATIONS

1. These remarks have been prepared with a view of pointing out the pertinent features of the various requirements and the precautions to be observed in the interpretation of the results of the tests.

2. The Committee would suggest that the acceptance or rejection under these specifications be based on tests made by an experienced person having the proper means for making the tests.

SPECIFIC GRAVITY

3. Specific gravity is useful in detecting adulteration. The results of tests of specific gravity are not necessarily conclusive as an indication of the quality of a cement, but when in combination with the results of other tests may afford valuable indications.

FINENESS

4. The sieves should be kept thoroughly dry.

TIME OF SETTING

5. Great care should be exercised to maintain the test pieces under uniform conditions as possible. A sudden change or wide range of temperature in the room in which the tests are made, a very dry or humid atmosphere, and other irregularities vitally affect the rate of setting.

¹ Reprinted, by permission, from the Proceedings of the Society, pages 301-305.

CONSTANCY OF VOLUME

6. The tests for constancy of volume are divided into two classes, the first normal, the second accelerated. The latter should be regarded as a precautionary test only, and not infallible. So many conditions enter into the making and interpreting of it that it should be used with extreme care.

7. In making the pats the greatest care should be exercised to avoid initial strains due to molding or to too rapid drying out during the first twenty-four hours. The pats should be preserved under the most uniform conditions possible, and rapid changes of temperature should be avoided.

8. The failure to meet the requirements of the accelerated tests need not be sufficient cause for rejection. The cement may, however, be held for twenty-eight days, and a retest made at the end of that period, using a new sample. Failure to meet the requirements at this time should be considered sufficient cause for rejection, although in the present state of our knowledge it cannot be said that such failure necessarily indicates unsoundness, nor can the cement be considered entirely satisfactory simply because it passes the tests.

SPECIFICATIONS

GENERAL CONDITIONS

1. All cement shall be inspected.
2. Cement may be inspected either at the place of manufacture or on the work.
3. In order to allow ample time for inspecting and testing, the cement should be stored in a suitable weather-tight building having the floor properly blocked or raised from the ground.
4. The cement shall be stored in such a manner as to permit easy access for proper inspection and identification of each shipment.
5. Every facility shall be provided by the Contractor and a period of at least twelve days allowed for the inspection and necessary tests.
6. Cement shall be delivered in suitable packages with the brand and name of manufacturer plainly marked thereon.
7. A bag of cement shall contain 94 pounds of cement net. Each barrel of Portland cement shall contain 4 bags, and each barrel of natural cement shall contain 3 bags of the above net weight.
8. Cement failing to meet the seven-day requirements may be held awaiting the results of the twenty-eight-day tests before rejection.
9. All tests shall be made in accordance with the methods proposed by

the Committee on Uniform Tests of Cement of the American Society of Civil Engineers, presented to the Society January 21, 1903, and amended January 20, 1904, and January 15, 1908, with all subsequent amendments thereto. (See addendum to these specifications.)

10. The acceptance or rejection shall be based on the following requirements:

NATURAL CEMENT

11. Definition. This term shall be applied to the finely pulverized product resulting from the calcination of an argillaceous limestone at a temperature only sufficient to drive off the carbonic acid gas.

FINENESS

12. It shall leave by weight a residue of not more than 10 per cent on the No. 100, and 30 per cent on the No. 200 sieve.

TIME OF SETTING

13. It shall not develop initial set in less than ten minutes; and shall not develop hard set in less than thirty minutes, or in more than three hours.

TENSILE STRENGTH

14. The minimum requirements for tensile strength for briquettes one square inch in cross section shall be as follows, and the cement shall show no retrogression in strength within the periods specified:

| <i>Age</i> | <i>Neat Cement</i> | <i>Strength</i> |
|--|--------------------|-----------------|
| 24 hours in moist air | | 75 lbs. |
| 7 days (1 day in moist air, 6 days in water) | | 150 " |
| 28 days (1 " " " " 27 " " ") | | 250 " |

One Part Cement, Three Parts Standard Ottawa Sand

| | |
|--|---------|
| 7 days (1 day in moist air, 6 days in water) | 50 lbs. |
| 28 days (1 " " " " 27 " " ") | 125 " |

CONSTANCY OF VOLUME

15. Pats of neat cement about three inches in diameter, one-half inch thick at center, tapering to a thin edge, shall be kept in moist air for a period of twenty-four hours.

(a) A pat is then kept in air at normal temperature.

(b) Another is kept in water maintained as near 70° F. as practicable.

16. These pats are observed at intervals for at least 28 days, and, to satisfactorily pass the tests, shall remain firm and hard and show no signs of distortion, checking, cracking, or disintegrating.

PORTLAND CEMENT

17. Definition. This term is applied to the finely pulverized product resulting from the calcination to incipient fusion of an intimate mixture of properly proportioned argillaceous and calcareous materials, and to which no addition greater than 3 per cent has been made subsequent to calcination.

SPECIFIC GRAVITY

18. The specific gravity of cement shall not be less than 3.10. Should the test of cement as received fall below this requirement, a second test may be made upon a sample ignited at a low red heat. The loss in weight of the ignited cement shall not exceed 4 per cent.

FINENESS

19. It shall leave by weight a residue of not more than 8 per cent on the No. 100, and not more than 25 per cent on the No. 200 sieve.

TIME OF SETTING

20. It shall not develop initial set in less than thirty minutes; and must develop hard set in not less than one hour, nor more than ten hours.

TENSILE STRENGTH

21. The minimum requirements for tensile strength for briquettes one square inch in cross section shall be as follows, and the cement shall show no retrogression in strength within the periods specified:

| <i>Age</i> | <i>Neat Cement</i> | <i>Strength</i> |
|--|--------------------|-----------------|
| 24 hours in moist air | | 175 lbs. |
| 7 days (1 day in moist air, 6 days in water) | | 500 " |
| 28 days (1 " " " " 27 " " ") | | 600 " |

One Part Cement, Three Parts Standard Ottawa Sand

| | |
|--|----------|
| 7 days (1 day in moist air, 6 days in water) | 200 lbs. |
| 28 days (1 " " " " 27 " " ") | 275 " |

CONSTANCY OF VOLUME

22. Pats of neat cement about three inches in diameter, one-half inch thick at the center, and tapering to a thin edge, shall be kept in moist air for a period of twenty-four hours.

(a) A pat is then kept in air at normal temperature and observed at intervals for at least 28 days.

(b) Another pat is kept in water maintained as near 70° F. as practicable, and observed at intervals for at least 28 days.

(c) A third pat is exposed in any convenient way in an atmosphere of steam, above boiling water, in a loosely closed vessel for five hours.

23. These pats, to satisfactorily pass the requirements, shall remain firm and hard, and show no signs of distortion, checking, cracking, or disintegrating.

SULPHURIC ACID AND MAGNESIA

24. The cement shall not contain more than 1.75 per cent of anhydrous sulphuric acid (SO_3), nor more than 4 per cent of magnesia (MgO).

These definitions and specifications are followed in the Society's Proceedings by detailed descriptions of the methods to be used in testing.

HYDRAULIC LIME

Hydraulic limes are not used to any great extent in this country, but in France the quantity manufactured is about as great as that of Portland cement.¹ The method of manufacture is similar to that used in the production of natural cement.

The material consists of an impure limestone, consisting of about 70 per cent calcium carbonate intimately blended by nature with clay and sand. In burning, a higher temperature is required than in the burning of lime. A complicated and elaborate process of screening, hydrating, and air separation is employed, forming the chief agency for yielding an efficient

¹ Fiebelkorn: *Hydraulischer Kalk und Zement in Süd-Frankreich*, published by Tonind. Zeit., Berlin (1911).

product. As the result of these operations, hydrated lime, hydraulic lime, and core are produced. The core, or unhydrated portion, which is usually ground, closely resembles Portland cement. The composition of hydraulic lime seems to vary within fairly wide limits as shown in Table 35.¹

TABLE 35.—Composition of Hydraulic Lime, Samples I, II, III

| | I | II | III |
|------------------------------|-------|-------|-------|
| Silica per cent | 24.42 | 16.80 | 14.97 |
| Alumina “ | 7.07 | 5.33 | 2.65 |
| Iron oxide “ | 2.37 | 1.79 | 0.96 |
| Calcium oxide “ | 52.83 | 59.88 | 61.61 |
| Magnesia “ | 0.43 | 0.76 | 0.14 |
| Sulphuric acid “ | 0.80 | 0.91 | 0.50 |
| Loss on ignition “ | 11.26 | 13.94 | 19.10 |

PUZZOLAN CEMENT

Puzzolan cements are of ancient usage, having been employed by the Romans in the construction of their famous aqueducts. This cement is made by grinding together a mixture of volcanic rocks (tufas) and lime. In the tufas, the silica is present partly as soluble silicic acid, or hydrous silicic acid, in which form it enters readily into combination with hydrated lime to form calcium silicates. The name Puzzolan is sometimes applied to slag cement, granulated slag being regarded as an artificial tufa.

In the United States natural tufas have not been used for the manufacture of a puzzolan cement, but they have been used for mixing with Portland cement, about 100,000 barrels of this mixed cement having been used in the construction of the Los Angeles aqueduct.² In view of the probable use of material of this type in the United States it would seem

¹ *Cement Eng. News*, 23, 205 (1911).

² *Cement Eng. News*, 23, 12 (1911).

appropriate for the sake of clearness to retain the name of *puzzolan* for cements containing natural silicates and use the term *slag cement* for mixtures of lime and artificial silicates.

An analysis of the tufa used in California resulted as follows:

| | | |
|--|-------|----------|
| Silica (SiO_2)..... | 67.10 | per cent |
| Alumina (Al_2O_3) and ferric oxide (Fe_2O_3) . . . | 15.60 | " |
| Lime (CaO)..... | 2.01 | " |
| Magnesia (MgO)..... | 1.75 | " |

The tufa was first finely ground and next intimately mixed with Portland cement, the best mixture consisting of equal parts of tufa and Portland cement. The admixture of tufa with Portland cement showed the following points in favor of the mixture: (1) it exhibits a more continuous ratio of increase in strength, and for a longer time, than Portland cement; (2) it possesses greater volume in equal weights; (3) it produces a surface of more uniform and higher color and eliminates the usual lime stains; (4) it is unfailingly sound, makes a smooth, impermeable surface, and is proof against sea water, sewage, and alkali.

Blast furnace slag is employed in the manufacture of *slag cements*. The slag is first granulated while in a molten state by cold water. This breaks up the more complex silicates, eliminates a portion of the sulphur, and causes a physical condition favorable for grinding. The granulated slag is ground in Griffen or tube mills; the product is mixed with lime, and finally ground again until 96 per cent of the mixture passes a 200 mesh sieve.

Slag cement has a blue color, low specific gravity (2.60 to 2.85), and is slow setting. On account of their sulphur content, slag cements are not suited for construction in salt water.

Blast furnace slags are now largely used for the manufacture of true Portland cement. Consequently slag cements

are not used as extensively as formerly. The relative importance of the two cements made from slag may be seen from the output during 1907 and 1908 in the United States, as follows:

| | 1907 | 1908 |
|---|-----------|-----------|
| Slag cement, in barrels. | 557,252 | 151,451 |
| Portland cement made from slag, in barrels. | 2,129,000 | 4,535,000 |

TABLE 36.—Analyses of Slags and Slag Cement (From Eckel's "Cement Materials and Industry")

| | <i>Slag cement</i> | <i>Blast furnace slag</i> | <i>Slag used in England</i> |
|--|------------------------|-----------------------------------|---------------------------------|
| Silica (SiO ₂) per cent | 28.95 | 32.20 | 32.90 |
| Alumina (Al ₂ O ₃) " | 11.40 | 15.50 | 13.25 |
| Iron oxide (Fe ₂ O ₃) " | 0.54 | | 13.25 |
| Lime (CaO) " | 50.29 | 48.14 | 47.30 |
| Magnesia (MgO) " | 2.96 | 2.27 | 1.37 |
| Sulphur (S) " | 1.37 | | 1.52 |
| Loss on ignition " | 3.39 | | |

LIME AND GYPSUM PRODUCTS

The general term lime is used to cover a variety of products. From a strictly chemical standpoint it refers, of course, to the oxide of calcium (CaO) only. Lime rock, on the other hand, is the term applied to that class of rock which contains 80 per cent, or more, of calcium carbonate or, possibly, of carbonate of calcium and magnesium, which, when calcined, produces a product that slakes upon the addition of water. The slaking of calcium oxide consists of a chemical action between itself and water. The product should properly be known as calcium hydroxide, but goes under the common name of slaked lime.

Gypsum occurs in nature as hydrated calcium sulphate

($\text{CaSO}_4 \cdot 2\text{H}_2\text{O}$), which, when calcined, is partially dehydrated and is then known as plaster of paris. When water is added to the latter, the hydrated sulphate of calcium of the same chemical composition as the gypsum is formed.

HYDRATED LIME

Limestone is a sedimentary rock consisting mainly of calcium carbonate, with impurities composed largely of clay and rock materials, such as silicates of iron and aluminum. When a considerable proportion of the rock consists of magnesium carbonate it is described as a dolomitic limestone.

Calcination.—The first step in the preparation of hydrated lime, is to calcine the limestone, which process drives off carbon dioxide according to the reaction $\text{CaCO}_3 \rightarrow \text{CaO} + \text{CO}_2$. This is done in kilns (Fig. 48), which are vertical shaft furnaces, shaped like inverted truncated cones, usually from eight to fifteen feet high and four to eight feet in diameter. Alternate layers of wood or coal and limestone are fed into the kiln from the top and the products of calcination are withdrawn at the bottom. In recent years modifications of the lime kiln have been made. These changes consist in burning the fuel in furnaces without mixing with the stone as above described; in higher kilns of less diameter; in the use of gas fired kilns in which producer gas and natural gas have been employed. The temperature¹ of calcination for pure limestone varies between 880°C . and 1200°C . If too low a temperature is maintained, some of the limestone remains as calcium carbonate, and if too high a temperature is employed, some of the lime combines with the silica, alumina, and other impurities, and remains inert so far as the subsequent process of slaking is concerned.

¹ For a full discussion on the burning temperature of limestone, the student is referred to *Transactions of the National Lime Manufacturers' Association*, February 2, 1911, page 68.

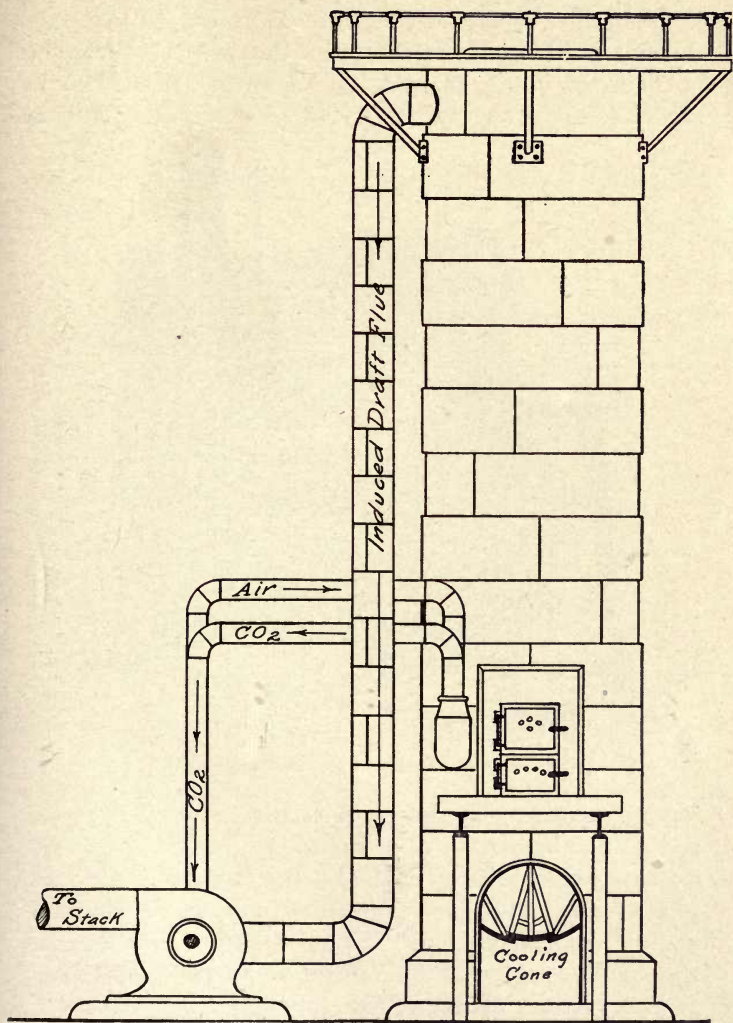

FIG. 48. Modern Type of Lime Kiln.

Hydration.—After burning, the lime is crushed to pieces less than three-eighths of an inch in diameter. In this condition it is fed into the mechanical hydrator, where the oxide is converted into a fine powder, known as hydrated lime, according to the reaction $\text{CaO} + \text{H}_2\text{O} \rightarrow \text{Ca}(\text{OH})_2$. Various

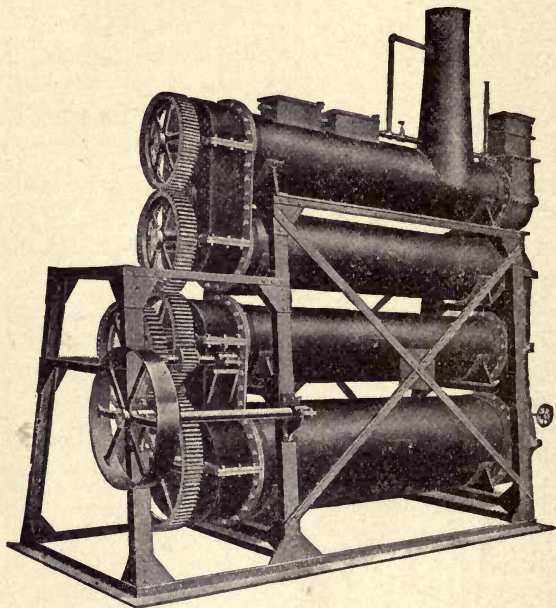

FIG. 49. Kritzer Lime Hydrator.

types of apparatus are in use, such as the Clyde,¹ Reaney¹ and Kritzer hydrators, all of which are similar in principle, since they provide for a definite amount of water to be added to a given weight of lime, and produce a product of constant and uniform composition. The following is a brief description² of the process used in a commercial plant which employs the Kritzer hydrator (Figs. 49, 50).

¹ Bulletins 4 and 5 (fourth series), Ohio Geological Survey, p. 329.

² *Pacific Builder and Engineer*, 12, 16 (1910).

The mechanical hydrators consist of six cylinders connected with a 40 foot stack which is water jacketed for 30 feet. The water in the jacket becomes heated to 110° F. by the gases given off during hydration. Each cylinder is arranged with a screw which moves the material in a direction

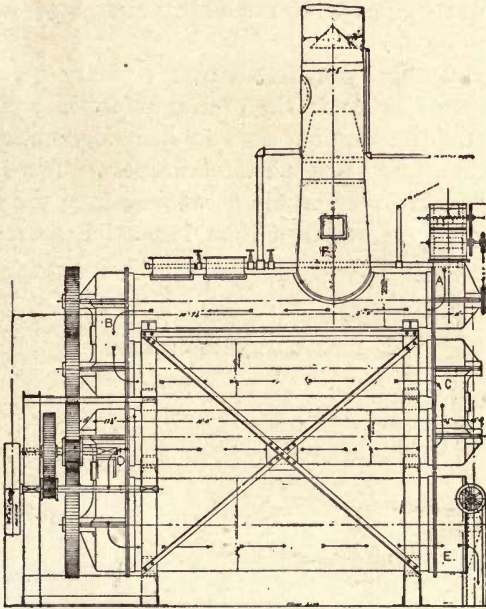

FIG. 50. Section through Kritzer Lime Hydrator (arrows show the course of the lime during hydration).

opposite to the flow of gases. The water supply is carefully regulated, about 30 pounds of water being required per 100 pounds of lime. The construction of the hydrator is such that no excessive heat accumulates at any point, thus producing a hydrated lime characterized by plasticity and freedom from crystallization. After passing 84 feet through the hydrator, the product is passed through screens and finally

through a cyclone fan, or air separator, in which the coarser particles are rejected.

Hydrated lime produced in this manner, when made from a limestone which carries 97.5 per cent calcium carbonate, contains 97.3 per cent calcium hydroxide, the remaining 2.7 per cent being mostly alumina. In respect of fineness, 100 per cent passes a 100 mesh sieve and 98 per cent a 200 mesh.

The advantage of hydrated over ordinary quicklime or caustic lime consists in the greater safety in storage, less liability to deterioration, ease in handling, uniformity of composition, and great physical fineness. The industrial uses of lime are very extensive, as seen from the following tabulated statement taken from Mineral Resources, U. S. Geological Survey, 1909.

INDUSTRIAL USES OF LIME

Agricultural industry:

- Soil amendment
- Insecticide
- Fungicide

Bleaching industry:

- Bleaching powder
- Bleaching and renovating of paper stocks.

Caustic alkali industry:

- | | | |
|------------|---|-------------|
| Soda | } | manufacture |
| Potash and | | |
| Ammonia | | |

Chemical manufacture:

- Potassium and sodium dichromate
- Magnesia, acetate of lime, wood alcohol, bone ash, calcium carbide, calcium light pencils, refining of mercury and dehydrating of alcohol

Gas manufacture:

- Purification of coal and water gas

Glass manufacture:

- Most varieties of glass

Milling industry:

Clarifying grain

Miscellaneous manufactures:

Rubber, glue, pottery and glazing

Dyeing fabrics, polishing material

Oil, fat and soap manufacture:

Soap, glycerine, candles, renovation of fats, tallow and butter, removing the acidity of oils and petroleum lubricating greases

Paint and varnish industry:

Cold water paint, refining linseed oil, linoleum, varnish

Paper industry:

Soda method

Sulphate method

Straw board

Filler

Sanitation:

Disinfectant and deodorizer

Purification of water for cities

Purification of sewage

Smelting industry:

Reduction of iron ores.

Sugar industry:

Beet sugar

Molasses

Tanning industry:

Tanning hides

Water softening.

The distribution of the lime produced in the United States in 1909 in short tons is as follows:

| | |
|--------------------------|-----------|
| Building uses. | 1,904,863 |
| Alkali works. | 12,820 |
| Chemical works. | 156,307 |
| Paper mills. | 274,912 |
| Sugar factories. | 13,787 |
| Tanneries. | 72,899 |
| Fertilizer. | 595,517 |
| Not specified. | 441,747 |
| | <hr/> |
| Total. | 3,472,952 |

SAND LIME BRICK

This product is also known as artificial sandstone and silica brick. Its manufacture is of considerable importance as shown by the following table: ¹

TABLE 37.—Manufacture of Sand Lime Brick in the United States

| <i>Year</i> | <i>Number of plants</i> | <i>Value of products</i> |
|-------------|-------------------------|--------------------------|
| 1903 | 16 | \$ 155,040 |
| 1904 | 57 | 463,128 |
| 1905 | 84 | 972,064 |
| 1906 | 87 | 1,170,005 |
| 1907 | 94 | 1,225,769 |
| 1909 | 74 | 1,150,580 |

A number of patented processes for the manufacture of sand lime products are in use. The real inventor, however, was W. Michaelis, Sr., whose theory of the hardening of cement has already been described. He believed that the colloidal matter was largely due to lime and silica, alumina being merely an accessory and largely superfluous substance. As the result he perfected his processes for the manufacture of hydraulic products from quartz, sand, and lime and founded an industry which now produces in Berlin about one thousand million sand lime brick annually.

The materials required are lime and some form of silica, usually sand. Lime may be used either as the oxide or the hydroxide (hydrate). If in the former state, some step in the process must provide for its hydration by the processes above described.

The silica used in the manufacture of sand lime brick should be free from loamy material, and at least 60 per cent should pass a 60 mesh sieve. It is usually passed through a drier

¹ Mineral Resources of United States (1910).

and into bins; thence into an automatic measuring device, which can be adjusted to yield the various mixtures of sand and lime. The mixtures employed in sand lime brick manufacture are given in Table 38.

TABLE 38.—Mixtures Used in Sand Lime Brick Manufacture

| <i>Hydrated lime</i> | <i>Sand</i> | <i>Compression</i> | <i>Steam pressure</i> | <i>Exposure to steam</i> | <i>Resistance to compression</i> |
|----------------------|---------------|----------------------------|----------------------------|--------------------------|----------------------------------|
| <i>p. ct.</i> | <i>p. ct.</i> | <i>pounds per sq. inch</i> | <i>pounds per sq. inch</i> | <i>hours</i> | <i>pounds per sq. inch</i> |
| 8 | 92 | 3750 | 120 | 6 | 1680 |
| 10 | 90 | 3750 | 120 | 6 | 2025 |
| 12 | 88 | 3750 | 120 | 6 | 2005 |

From the measuring machine the material is conveyed to a tube mill for thorough mixing and grinding, thence discharged into a pug mill where water is added for tempering to bring about the necessary plasticity, after which the tempered material is fed into the presses, moulded into the desired shape, and the brick loaded on steel cars. The latter are next run into an iron cylindrical retort 66 feet long and 6 feet in diameter (Fig. 51), steam under a pressure of 120 to 125 pounds is turned on for from 6 to 9 hours, after which the brick is ready for use.

By the action of the temperature and pressure of the steam, a hydrated mono-calcium silicate ($\text{CaOSiO}_2\text{H}_2\text{O}$) is formed, which is the hydraulic constituent. It will be seen that, although this result is the same as in the hardening of Portland cement, it is obtained in quite a different manner. In the latter case, a compound is made by incipient infusion, water is added at ordinary temperatures, and the clinker compound decomposes with the formation after some days of hydrated mono-calcium silicate ($\text{CaOSiO}_2\text{H}_2\text{O}$). In the lime silica brick the same product is formed by synthetic action in the period of six hours.

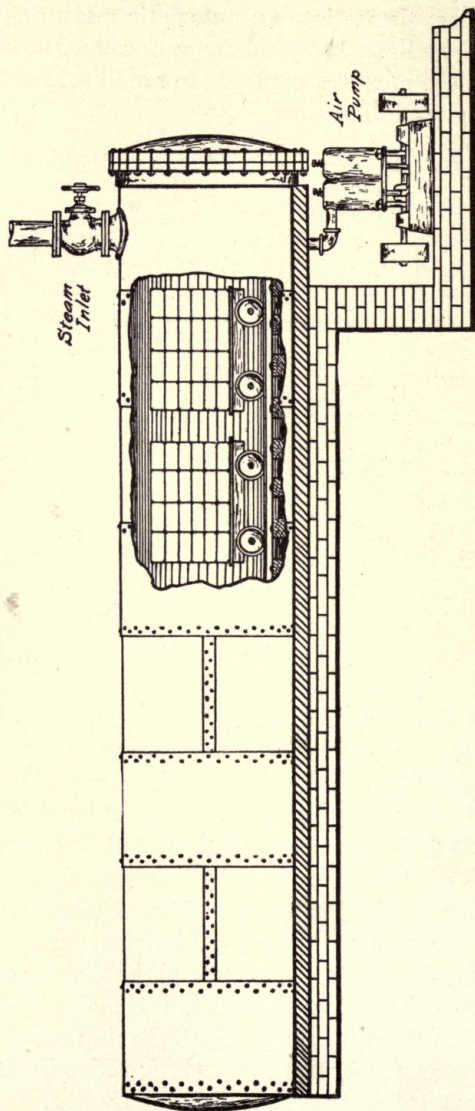

FIG. 51. Pressure Cylinder Used in the Manufacture of Sand Lime Brick.

Various objections have been advanced against the use of sand lime brick, absorption of water and lime stains being the principal. These defects have largely been overcome by the use of completely hydrated lime and the finer grinding of pure silicious sand.

STUCCO AND PLASTERS

The materials used for plastering over wooden or metal laths on walls consist of hydraulic cement, lime, wood fiber, sand, and gypsum. Inasmuch as gypsum finds its way into structural materials under a number of trade names, involving more or less confusion, it is desirable to discuss gypsum products more fully before considering the composition and properties of wall plasters in general.

Crude gypsum occurs distributed over the United States in various forms, as rock gypsum, gypsite (earthy gypsum), and gypsum sands. The crystalline transparent form is called selenite. The quantity of crude gypsum mined in 1908 was 1,721,829 tons, of which 37,672 was ground in the crude form and sold as land plaster.

Gypsum is a hydrated sulphate of lime $\text{CaSO}_4 \cdot 2\text{H}_2\text{O}$. When heated to between 100° and 170° C., it is partially dehydrated, the reaction being represented by the equation:

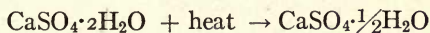

This product is known commercially as plaster of paris. Upon these reactions the classification¹ of gypsum products is based, as follows:

- A. Produced by incomplete dehydration of gypsum at a temperature not exceeding 400° F.
 1. From calcination of pure gypsum—plaster of paris.
 2. From calcination of impure gypsum—cement plaster, which is characterized by slow setting.

¹ Mineral Resources of the United States (1905), p. 1112.

B. Produced by complete dehydration of gypsum at a temperature exceeding 400° F.

1. From calcination of pure gypsum—flooring plaster.
2. From calcination of gypsum at red heat and addition of alum or borax—hard finish plaster.

Certain trade names may be defined. "Calcined" plaster refers to the plaster of Paris or cement plaster above defined. "Wall" plaster is plaster containing retarding substances and hair or pulp. "Parian cement" is a hard finish plaster. The "cement plaster" is in no way related to the hydraulic cements, the setting properties being due to the formation of the original hydrated compound:

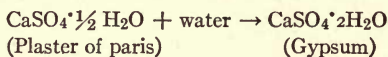

HYDRAULIC GYPSUM

Hydraulic gypsum may be prepared by employing a temperature of about 900°–1300° C. This produces, according to the researches of Glasenapp,¹ a mixture of granular, densely vitrified, hard, crystalline modification of anhydrous calcium sulphate with small amounts of fused, amorphous basic anhydride containing calcium oxide. When water is added to this mixture, it retains its form and no crystallization takes place except a very minute quantity of calcium hydroxide and calcium sulphate crystals. The following table shows the products obtained at various temperatures:

1. Crude gypsum. Di-hydrate of calcium sulphate.
2. Heated 107°– 170° C. Half hydrate of calcium sulphate and commercial plaster of paris.
3. Heated 170°– 200° C. Nearly dehydrated calcium sulphate which readily takes up water to form the half hydrate. Commercial plaster of paris.

¹The Manufacture of Hydraulic Gypsum, published by *Cement Eng. News*, 1910.

4. Heated 200°- 250° C... .More nearly dehydrated. Sets more slowly than the former.
5. Heated 250°- 400° C... .Only a trace of water, slow setting.
6. Heated 400°- 750° C... .Completely dehydrated. Will not harden when water is added. Known as "dead burnt."
7. Heated 750°- 800° C... .Formation of granular anhydride. Does not harden.
8. Heated 800°- 900° C... .Hydraulic gypsum with minute grains of anhydride.
9. Heated 900°- 1000° C... .Hydraulic gypsum with grains of anhydride fully developed.
10. Heated 1000°- 1400° C... .Hydraulic gypsum with grains increasing in size. The basic calcium sulphate likewise increases with rising temperature.

Hydraulic gypsum is used as a substitute for white Portland cement and in architectural designs and ornamentation where great strength and hardness are required.

The old fashioned *wall plaster* consisted of a mixture of lime plaster and sand with a quantity of hair or wood pulp to give added strength. The excess water in such plaster must be removed by evaporation. To hasten the drying, plaster of paris is added. This serves to take up the excess water in forming the hydrated calcium sulphate. In modern practice the use of metal lath has brought forward an objection against gypsum on account of its tendency to corrode the metal, due perhaps to the gradual liberation of sulphuric acid. To overcome this tendency toward corrosion and yet introduce a drying agent similar in properties to gypsum, various lime plasters containing Portland cement or calcium aluminate compounds are used to an increasing extent.

Stucco is the name given to plasters used on exterior walls, where obviously a quick drying, impervious, and resistant material must be employed. Various mixtures are employed, but in general they consist of about 1 part Portland cement, 3 parts sand, $\frac{1}{2}$ to 1 part lime, and some fiber. The final

coat usually has added some coarser material, such as crushed granite or cinders, to give a rough pebbled surface.

Wall plasters for interior use may consist of lime, sand, and fiber, or of plaster of paris, sand, lime, and fiber. The more recent Alca¹ (named from symbols of aluminum and calcium) plasters consist of hydrated lime, calcium aluminate, and sand. The function of the calcium aluminate is similar to that of the compounds active in the hardening of Portland cement, viz., to assist in drying the plaster by absorbing the excess water in hydrating.

REFERENCES

I

- BLEININGER: The Manufacture of Hydraulic Cements, Ohio Geol. Survey (Fourth Series), Bull. 3 (1904).
 BLEININGER: The Uses of Hydraulic Cements, Ohio Geol. Survey (Fourth Series), Bull. 2 (1904).
 DESCH: Chemistry and Testing of Cement.
 ECKELS: Cements, Limes and Plasters.
 ECKELS: Cement Materials, U. S. Geol. Survey Bulletin 522.
 FALK: Cements, Mortars, and Concretes.
 GRANT: Portland Cement: its Nature, Tests and Uses.
 LECHATELIER: Experimental Researches on the Constitution of Hydraulic Mortars. (Translation by J. L. Mack.)
 MEADE: The Examination of Portland Cement.
 MEADE: Portland Cement, its Composition, Raw Materials, Manufacture, and Analysis.
 MICHAELIS: The Hardening of Cement under Water.
 PARR AND ERNEST: A Study of Sand Lime Brick, Bull. 18, Illinois Geol. Survey.
 REDGRAVE AND SPACKMAN: Calcareous Cements, their Nature and Use.
 TAYLOR: Practical Cement Testing.

II

- BARTLETT: Manufacture of Plaster of Paris. *Eng. Min. J.*, 82, 1063 (1906).
 ECKEL: Cement Production and Manufacture in the United States. *Eng. Mag.*, 30, 715 (1906).

¹ *Rock Products*, 10, 37 (1911).

- GRIMSHAW: Industrial Application of Gypsum. *Sci. Am. Sup.*, **61**, 25476; **62**, 25702 (1906).
- LEWIS: Machinery and Processes in Modern Portland Cement Plant. *Eng. Mag.*, **31**, 884; **32**, 210 (1906).
- WOOLSON: Sand Lime Brick. *Eng. News.*, **55**, 662 (1906).
- NICHOLAS: Effect of Electric Currents upon Concrete and Steel. *Eng. News*, **57**, 328 (1907).
- NICHOLAS: Effect of Electric Currents upon Concrete and Steel. *Eng. News*, **60**, 710 (1908).
- WILSON: Modern Lime Kilns. *Eng. News*, **59**, 109 (1908).
- NICHOLAS: Effect of Electric Currents upon Concrete and Steel. *Eng. News*, **61**, 458 (1909).
- SMITH: Free Lime in Portland Cement. *J. Ind. Eng. Chem.*, **1**, 668 (1909).
- WHITE: Free Lime in Portland Cement. *J. Ind. Eng. Chem.*, **1**, 5 (1909).
- ACKERLIND: Sand Lime Brick. *Rock Products*, **10**, 37 (1910).
- BURCHARTZ: The Behavior of Hydraulic Compounds in Sea Water. *Cement Eng. News*, **22**, 421 (1910).
- BURCHARTZ: The New German Standard and Specifications for Cement. *Eng. Rec.*, **61**, 819 (1910).
- DURYEE: Puzzolan Portland Cement. *Eng. News*, **64**, 596-8 (1910).
- ERNEST: Fire Tests on Sand Lime Brick. *Trans. Am. Ceram. Soc.*, **12**, 83 (1910).
- LAZELL: Comparative Tests of Lime Mortar. *Am. Soc. Test. Materials*, **10**, 328 (1910).
- MOYER: Use of Mineral Oils Mixed with Concrete. *Eng. Rec.*, **61**, 10 (1910).
- NICHOLAS: Effect of Electric Currents upon Concrete and Steel. *Eng. News*, **64**, 590 (1910).
- NORTON: Some Thermal Properties of Concrete. *Eng. News*, **64**, 711 (1910).
- POULSEN: Long Time Tests on Concrete in Sea Water. *Eng. News*, **64**, 3 (1910).
- PERRING: Gypsum as a Fire Proofing Material. *Eng. Rec.*, **62**, 649 (1910).
- ROWAN: Effect of Sea Water, Alkali Water and Sewage on Portland Cement. *Eng. Contr.*, July 20 (1910).
- SPACKMAN: Aluminates as Addition to Wall Plaster. *Proc. Am. Soc. Test. Mat.*, **9**, 315 (1910).
- WILLEY: Engineering Works in Concrete. *Cassier*, **38**, 138 (1910).
- BLEININGER AND EMLEY: The Burning Temperature of Limestones. *Trans. Amer. Ceramic Soc.*, **13**, 618 (1911).
- HAGAR: Manufacture of Portland Cement from Slag. *Eng. News*, **66**, 314 (1911).

- KEMPSTER: Portland Cement from Blast Furnace Slag. *J. Ind. Eng. Chem.*, **3**, 33 (1911).
- LOHMAN: Magnesium Oxychloride in Magnesia Cement. *Tonind. Ztg.*, **35**, 256 (1911).
- LIPPINCOTT: Tufa Concrete on the Los Angeles Aqueduct. *Cement Age*, **12**, 8690 (1911); see also *Proc. Am. Soc. Civ. Eng.*, **38**, 1191 (1912).
- MAGNUSSON AND SMITH: Electrolytic Corrosion in Reinforced Concrete. *Proc. Am. Inst. Elect. Eng.*, **30**, 2055 (1911).
- MEADE: Manufacture and Properties of Hydrated Lime. *Eng. News*, **65**, 554 (1911).
- DONATH: Chemistry of Iron Concrete. *Zeit. angew. Chem.*, **24**, 1398 (1911).
- MICHAELIS: Portland Cement Reground with Oregon Pozzuolana. *Cement Eng. News*, **23**, 352 (1911).
- NOBEL: The Prevention of Corrosion in Metal Laths. *Cement*, **12**, 48 (1911).
- SCHMIDT: Magnesia Cement and Artificial Stone. *Tonind. Ztg.*, **35**, 180 (1911).
- WILEY AND ERNST: A Scheme for the Rapid Analysis of Cement. *J. Ind. Eng. Chem.*, **3**, 551 (1911).
- Specifications for Concrete and Brick Masonry in Sewers and Appurtenances. *Eng. Contr.*, **38**, 72 (1912).
- CARPENTER: Adulteration of Portland Cement. *Eng. News*, **67**, 94 (1912).
- DAVIS: Impermeability Tests on Concrete. *Eng. News*, **68**, 866 (1912).
- FORCE: Autoclave Boiling Test for Cement. *Eng. News*, **67**, 1111 (1912).
- GANO: The Boiling and Steam Tests of Cement. *Eng. News*, **67**, 980 (1912).
- HANCOCK: Lime Silica Brick. *Chem. World*, **1**, 13 (1912).
- HUMPHREY AND LOSSE: Reinforced Concrete Beam Tests. U. S. Bureau of Standards, Technical Paper No. 2 (1912).
- LARNED: A Study of Sand for Use in Cement Mortar and Concrete. *J. Assoc. Eng. Soc.*, **48**, 189 (1912).
- MEYLE: The Theories of the Hardening of the Hydraulic Cements. *Z. angew. Chem.*, **25**, 711 (1912).
- PERROT: Fire Proof Construction. *Proc. Eng. Soc. Western Pa.*, **27**, 55 (1912).
- Proposed Standard Specifications for Portland Cement, by Conference U. S. Govt. Dept. Heads., *Chem. Abs.*, **6**, 280 (1912). See Cir. 33, Bureau of Standards, U. S. Dept. of Commerce and Labor (1910).

CHAPTER XIII

PAVING MATERIALS AND WOOD PRESERVATION

THE construction of roads and pavements has brought into use a large variety of materials to produce a hard and somewhat permanent surface. For this purpose a material must have wearing properties, and be capable of withstanding abrasion and sustaining heavy burdens. To prevent disintegration of the road materials into dust, certain classes of products have come into use, known as *road binders*, and in some cases as *dust preventives*. The materials used in a crude form to cover and protect the natural earth foundation of a road from direct action of water and traffic are gravel, broken stone, slag, wood, stone blocks, etc. The permanency of such materials, however, depends upon the manner of construction of the road and pavement surface, involving proper drainage and the use of a suitable binding agency.

From the standpoint of the chemistry of road materials, we are more largely concerned with manufactured materials, such as paving brick, chemically treated wood blocks, and road binders. The latter constitute a considerable field by themselves and have been classified by Hubbard¹ on the basis of their chemical characteristics as follows:

I. Non-bituminous materials.

1. Inorganic.
2. Organic.

II. Bituminous materials.

1. Petroleums, petroleum products and solid native bitumens.
2. Tars and tar products.

¹ Dust Preventives and Road Binders, p. 32.

PAVING BRICK

The manufacture of paving brick from suitable clay has already been discussed in Chapter XI together with the enumeration of the properties and requisites of this class of material.

CHEMICALLY TREATED WOOD BLOCKS

In a crude form, wood has been used extensively as a road material in the construction of corduroy roads in the country and planked streets in cities. It has, however, always been replaced by more permanent materials as soon as practicable. Wooden blocks of various shapes laid upon a well rolled earthen surface have also been used, but have proved unsatisfactory. Recently the use of wood blocks, chemically treated so as to preserve them from decay, and laid upon a concrete foundation, has again brought wood into prominence as a paving material. More than 2,000,000 square yards of this type of pavement have been laid in the United States during the last ten years, while London has used them for thirty years and Paris has four times as many square yards of treated wood blocks as of asphalt. Therefore a discussion of the principles of wood preservation is of special interest.

Wood is made up of small fibers, the various forms of which are determined by the cell structure. The main constituents of these cells are walls, essentially cellulose ($C_6H_{10}O_5$), and their contents, which consist of air and sap. The sap consists of water, protein matter, gums, organic acids, coloring matter, sugar, volatile oils, and resins. Differences in strength of timber equally seasoned are due to the differences in structure or in form and disposition of the fibers.

Decay of wood is mainly due to the fermentation of the sap, the fiber by itself being much more resistant to decay. The agencies of decay are bacteria and moulds which can

thrive only in the presence of air, moisture, warmth and a food supply. In the absence of any one of these conditions the life of these decomposing agents is interfered with and the process of decomposition of the wood cannot take place.

WOOD PRESERVATIVES

The preservation of wood is dependent upon the removal of sap (i. e., the food supply of the microorganisms), and upon the introduction of antiseptic solutions, to poison the organisms, or solutions which have the power to change the character of the cell contents. The substances used for these purposes are *copper sulphate*, *mercuric chloride*, *zinc chloride*, and *creosote oils*.

Copper sulphate (blue vitrol) has long been known as a strong antiseptic and its application to wood preservation has extended over a period of sixty years. It should be free from sulphate of iron, which is easily decomposed, yielding free sulphuric acid, which weakens the wood fiber. The strength required is a 1 per cent solution. An objection to the use of copper sulphate is the cost of a treating plant since the apparatus used in the process must be made of copper. The use of wood thus treated is also limited since iron nails, spikes, etc., will decompose the copper sulphate. The solubility of copper sulphate likewise renders it easily washed out by rain and moisture. To overcome the latter objection the Thilmany process was devised, in which wood is immersed in a bath of barium chloride after it has been saturated with copper sulphate. This forms insoluble barium sulphate in the pores of the wood, which acts as a seal against moisture.

Mercuric chloride (corrosive sublimate) was applied to wood preservation by John Howard Kyan in England in 1833. It coagulates protein, is a strong antiseptic and very poisonous. The strength of the solution used is about 0.7 to 1 per cent. Since it attacks iron and wooden apparatus, vessels protected by coal tar coating are used in the process. The term Kyan-

izing is applied to wood preservation in which mercuric chloride is used.

The use of *zinc chloride* was patented by Burnett in England in 1838. The solution is prepared by dissolving metallic zinc in hydrochloric acid. It generally holds about 25 per cent of zinc, its specific gravity being 1.6. It should be free from hydrochloric acid and chloride of iron. It has a great affinity for wood fiber, is hygroscopic, and is a powerful antiseptic. The term "Burnettizing" is applied to the process.

The use of *heavy oil of coal tar* was patented in England in 1838 by Bethell, the name "creosoting" being given to the process (creosote being considered the active preservative agent). Coal tar creosote has replaced most of the other preservative agents on account of its insolubility, antiseptic properties, and the cheapness of the process.

The properties which a coal tar creosote must possess are the subject of specifications of a somewhat diverse character. Much stress is laid upon its composition as determined by distillation according to the Von Schrenk method.¹ A creosote treated by this method by the author gave the following results in percentages by weight on the water-free oil:

| | |
|-----------------------------------|---------------|
| Below 170° C. | 0.00 |
| 170°-200° | 0.73 |
| 200°-210° | 1.14 |
| 210°-235° | 11.52 |
| 235°-270° | 24.35 |
| 270°-315° | 19.16 |
| 315°-355° | 22.56 |
| Residue. | 20.49 |
| Loss. | 0.58 |
| Specific gravity at 38° | 1.055 |
| Water in oil. | 2.50 per cent |
| Tar acids. | 5.83 " |
| Sulphonation. | 1.30 " |

¹ *Proc. Am. Ry. Maintenance Way Assoc.*, 9, 708 (1908).

It will appear from the above that coal tar creosote differs from crude coal tar in the absence of the light oils and in the smaller quantity of the pitch residue. Its active constituents are naphthalene and anthracene which are forced into the wood in a liquid condition where they are subsequently solidified and become permanent, as is evident from the relatively high percentage of the naphthalene and anthracene fractions in creosotes¹ extracted from timbers which have been in service for twenty years or more. These analyses show that oils which distill below 205° C. do not remain in the wood and that about 60 per cent of the oils that do remain distill above 270° C.

| Samples | Average service Years | Creosote per cubic feet, lbs. | Distillation of Extracted Oil | | | | | | Naphthalene p. ct. | Anthracene p. ct. | Tar acids in cc. | |
|---|--------------------------|----------------------------------|-------------------------------|--------|-----------------|--------|-----------------|--------|-----------------------|----------------------|---------------------|-------------------|
| | | | Below 205° C. | | 205° to 270° | | 270° to 320° | | | | | Residue p. ct. |
| | | | p. ct. | p. ct. | p. ct. | p. ct. | p. ct. | p. ct. | | | | |
| 19 cross ties. | 21.8 | 9.58 | 0.02 | 12.07 | 13.88 | 23.80 | 24.69 | 25.27 | 1.19 | 23.4 | 0.65 | |
| 4 paving blocks. . . | 23.6 | 15.70 | 0.29 | 21.39 | 28.39 | 18.73 | 19.40 | 18.64 | 12.52 | 40.4 | 0.52 | |
| 6 piles. | 20.2 | 15.64 | 0.57 | 30.28 | 15.82 | 18.49 | 13.21 | 21.43 | 25.93 | 43.3 | | |
| 1 paving block, poor service | 9.0 | 5.77 | 9.62 | 14.41 | 19.27 | 41.74 | 11.23 | 3.40 | | | | |

The natural inference from the above results is that the efficiency of creosote depends upon the large proportion of its heavy boiling constituents. The name "tar acid" is a technical term given to such substances as phenols, cresols, naphthol, and xylenol. The proportion of tar acids in creosote is usually about 5 per cent, while the extracted creosote contains less than 1 per cent. The tar acids possess, therefore, poor staying qualities, the most valuable constituent in creosote appearing to be anthracene oil.

A number of patented products are now in use in the preparation of wooden blocks for paving purposes. One of

¹ Circular 98, Forest Service, U. S. Dept. of Agriculture.

the early compounds thus prepared was called "carbolineum" by its inventor, R. Avenarius, an officer in the Prussian army. This compound is now called "carbolineum avenarius." Its basis is the dead oil of coal tar obtained from the redistillation of coal tar creosote. A sample of carbolineum avenarius analyzed in the author's laboratory gave the following results:

| | |
|---|---------|
| Specific gravity 17° C. | 1.122 |
| Viscosity at 17° C. (P. R. R. pipette).... | 2.14 |
| Ash, per cent. | 0.03 |
| Flash point. | 135° C. |
| Burning point. | 180° C. |
| Distillation (Von Schrenk app.): Percentage by weight | |
| Below 235° C. | 2.12 |
| 235-300° C. | 6.45 |
| Residue (fluid) | 91.16 |
| Phenol. | Trace |
| Naphthalene. | None |

The creo-resinate process is another modification in the use of creosote for preserving wooden blocks. After the wood has been subjected to a dry heat to kill the germs, a mixture of melted rosin and creosote (1:1) is forced into the wood. The rosin solidifies on cooling, thus sealing the pores of the wood and preventing the evaporation of the creosote or its displacement by water.

METHODS OF WOOD PRESERVATION

The most common methods of timber preservation by creosoting are known as *full cell* impregnation, *empty cell* impregnation, and *open tank* treatment.

In *full cell impregnation* the wood is first air dried, so that it does not contain more than 20 per cent moisture. It is next put into an iron cylinder and subjected to a vacuum powerful enough to remove the air from the cells of the wood. The creosote oil is then caused to enter this cylinder and a

pressure of 70 to 100 pounds per square inch is applied to force the oil into the cells of the wood. The cells therefore become filled with oil (whence the name of this process) instead of air and sap.

In the *empty cell* impregnation the wood is seasoned as before, put into the impregnating cylinder and subjected to 60 to 65 pounds pressure of air. This causes all the cells of the wood to be filled with compressed air. Without reducing the pressure the warm impregnating fluid is forced from its reservoir into the cylinder under a somewhat higher pressure, after allowing a volume of air to escape which is equivalent to the volume of the liquid. The final pressure then applied is 105 to 205 pounds. The principle upon which this practice is based is that, owing to high pressure, the oil in consequence of the capillarity of the wood and its adhesive properties moves along the cell walls of the wood, soaking them entirely and compressing the air still more. When the pressure is released the excess oil is forced out, leaving the cell walls coated with oil and the cells full of air. This process gets its name from the fact that the cells are "empty" of the preservative liquid.

The *open tank* method makes use of an open tank capable of being heated by means of steam coils or fire underneath. The preservative fluid is run into the tank, covering the timber to be treated, and the temperature of the liquid is then raised slightly above the boiling point of water. This temperature is maintained for some time and the timber is then quickly transferred to another vat containing a cold preservative. The principle utilized by this method is that of creating a vacuum by the expulsion of the moisture and sap in the cells of the wood and by the expansion of the air of the cells. The contraction of the air in cooling draws the preserving fluid into the interior of the wood.

The operation of an open tank wood preservation plant is very simple and capable of wide application as shown in

Fig. 52, which illustrates the construction of a tank used for treating fence posts.

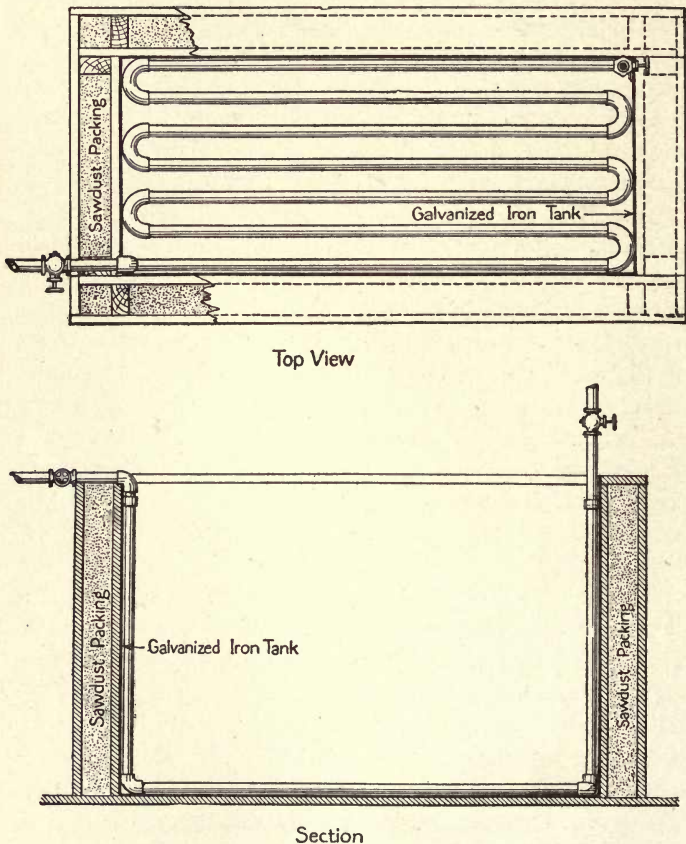

FIG. 52. Sectional and Top Views of Open Tank used in Wood Preservation.

Any of the preservatives in general use can be applied by the open tank method, provided that the temperatures are properly controlled. Oils with high boiling points are applied

with less difficulty and less loss by evaporation than those with low boiling points. In applying preservatives held in water solution some of the water is evaporated during the treatment, with a consequent concentration of the solution; but treatment can easily be regulated either by the addition of hot water during treatment, or, better, by starting with a solution slightly weaker than desired for impregnation.

The use of wood for paving purposes is largely dependent upon proper creosoting. Dried and seasoned wood may absorb as much as 24 pounds of moisture per cubic foot, while properly creosoted wood does not absorb any perceptible amount. Untreated wood when moistened expands $\frac{1}{2}$ inch per cubic foot, while creosoted wood suffers but little expansion. Creosoting also increases the hardness of wood. Creosoted wooden block pavements are in use in Boston, New York, Chicago, Baltimore and other cities of the United States, and have proven very satisfactory from the standpoint of durability and in being less noisy than brick or stone, and also offering low tractive resistance (i. e., resistance to the movement of a load on a level surface).

ROAD BINDERS

The function of road binders (or binding bases) is to cement the road materials together and prevent their removal in the form of dust, to render the surface impervious to water, and to eliminate internal wear. The material which is thus bound together by the cementing agency may vary greatly. For example, the petrolithic road consists of soil and binder; concrete is composed of sand and gravel or broken stone and binder; bituminous concrete (macadam) is composed of crushed rock and binder; sheet asphalt pavement consists of sand and binder imposed upon a layer of crushed stone and binder. Since we are mainly concerned with the properties of the binders and not with the methods

of road construction it will be sufficient, for our purpose, to consider the materials more commonly used for binding purposes. The inorganic binders used as dust preventives, aside from the general use of water itself, are deliquescent salts, such as magnesium chloride obtained from sea water or salt works, and calcium chloride which is a by-product of the Solvay soda process. To a limited extent sodium silicate is used as a binder in the construction of Rocmac, a system of limestone macadam.

PORTLAND CEMENT

The most important inorganic binder is Portland cement. This material has been fully described in Chapter XII and only its application as a road material need be noted here. Its great strength and permanency make it ideal for a foundation but owing to its rigidity and liability to crack on account of temperature changes, its use for pavement surfaces has not always proved successful. For a full discussion of the defects and proposed remedies in Portland cement as a wearing surface for roads, the student is referred to articles by Dr. L. W. Page, in *Cement Age*, January, 1910, page 37, and *Eng. Record*, Dec. 25, 1909, page 724.

ORGANIC BINDERS

Very few organic binders of a non-bituminous character have been employed. Those available are waste sulphite liquor (see Chapter XVI) which in a concentrated form has been found to possess considerable binding power, and waste molasses, a by-product of the sugar industry. Sugar reacts with lime to form the sucrates, which are highly plastic compounds, but are soluble in water and are usually water-proofed with petroleum oil.

Among the organic binders, petroleum products are of chief importance. The nature of the petroleums has been

discussed in Chapter VII, but the use of certain petroleum products in road construction requires fuller explanation. Among these products may be mentioned *road oil*, *cut back oil*, *fluid residues*, and *oil asphalt*.

Road oil is the name given to semi-asphaltic and asphaltic petroleums from which the lighter oils have been removed. The way in which it differs from the crude oil may be noted in the following data taken in part from Hubbard: ¹

| | <i>Crude oil</i> | <i>Road oil</i> ² |
|---------------------------------------|------------------|------------------------------|
| Specific gravity at 25° C. | 0.939 | 0.958 |
| Flash point, ° C. | 26° | 159° |
| Volatile at 205° C., 7 hours. | 42.7% | 8.78% |

Oil is used as a semi-permanent binder for a variety of purposes such as spraying upon the surface of existing macadam roads, and for mixing with the dirt of a country road to suppress dust.

Cut back oil represents a solid oil asphalt dissolved in about one-fourth its weight of light volatile oil. It has many characteristics in common with the road oil just described, but it has a low flash point. The binding base is suitable in consistency for a permanent binder, but differs in its mode of application since it has the consistency of a road oil.

Fluid residuums are obtained by a more complete distillation of petroleum. The composition of the California residuum is indicated by the following constants, compared with cut back oil:

| | <i>Cut back oil</i> | <i>Fluid residuum</i> |
|---------------------------------------|---------------------|-----------------------|
| Specific gravity at 25° C. | 0.942 | 1.006 |
| Flash point, ° C. | 32° | 191° |
| Volatile at 205° C., 7 hours. | 20.12 ³ | 17.3 |

¹ Dust Preventives and Road Binders, p. 162.

² From analyses in the author's laboratory.

³ At 163° C., 5 hours.

The fluid residuums are used to a large extent as fluxes, i. e., thinners for the solid asphalts, and as permanent binders in bituminous concrete.

Oil asphalt represents the product which remains after California and Texas petroleums (q. v.) have been heated to 700° F. Below this temperature these petroleums yield gasolene, kerosene, and lubricating oils, the solid residue which remains being known as artificial or domestic asphalt. The quantity thus produced in 1909 in California and Texas amounted to 128,861 tons. Since this asphalt conforms to the same tests which govern the use of asphalt in general, it will be more convenient to first discuss *native* or *natural asphalt* and then continue the discussion of the properties of asphalt as common to both kinds.

Native asphalt occurs in Trinidad, Bermudez, Venezuela, Cuba, Mexico, and to a small extent in California. The Trinidad asphalt forms a lake which is thought to be the crater of an extinct volcano.¹ The lake has an area of over 100 acres and is of unknown depth. The estimated minimum tonnage is 9,000,000 tons. Its structure is of sufficient hardness to permit teams for loading, but all excavations are filled again by the flowing of asphalt. From Trinidad a land asphalt is also obtained, which is thought to be an overflow from the lake or the remnant of some former subterranean source. In 1909 more than 97,000 tons of lake and 13,000 tons of land asphalt were imported into the United States from Trinidad.

The refining of native asphalt consists in the removal of water and other impurities by heating in large tanks fitted with air or steam agitators. Water and gases are given off, vegetable matter may be skimmed off, and the purified asphalt in the molten condition is poured into barrels, where it solidifies and is ready for use.

In addition to the large deposits of the native asphalt above

¹ Richardson: *J. Soc. Chem. Ind.*, 17, 13 (1898).

described there are numerous *solid hydrocarbons* which have been described as mineral species and given specific names. Among these are ozokerite,¹ an important source of paraffin; grahamite,² a black solid mixture of hydrocarbons filling vein-like fissures in the country rock; and gilsonite³ another black, brittle, lustrous mixture of hydrocarbons found in the Uinta Mountains, Utah.

Certain tests are designed to give a means of identification and furnish an index of the character of the material. These tests⁴ are of a more or less empirical nature, but give us an approximation of the behavior of asphalt under service conditions.

PHYSICAL PROPERTIES OF ASPHALT

The *specific gravity* of asphalt varies from 0.995 to 1.07. If the specific gravity is higher it is an indication of the presence of mineral matter, usually found in the native asphalt. When this value is less than 0.995, the material is not suitable for paving purposes, since it will contain too large a percentage of volatile matter for permanent use.

The *hardness* of asphaltic materials is determined by the penetration test. For this purpose a Dow machine with a No. 2 needle under a 100 gram weight is employed. Asphaltic cement (a mixture of refined asphalt and flux) should not give a higher penetration than 15mm. in 5 seconds at 25° C. since it would soften in hot weather. Too low penetration results indicate that the asphalt is liable to be damaged during cold weather on account of brittleness. The usual penetration is from 6 to 10 mm.

¹ Newberry: *Am. J. Sci.*, 3d ser., 17, 340 (1879). See also Gosling's bibliography of the mineral, *School of Mines Quar.*, 16, 41 (1894).

² White: *Bul. Geol. Soc. America*, 10, 277 (1898).

³ Day: *J. Frank. Inst.*, 140, 221 (1895); also Bull. 213, U. S. Geol. Survey, p. 296 (1903).

⁴ For details of the tests see Bull. 38, Office of Public Roads, U. S. Dept. of Agriculture (Methods for the Examination of Bituminous Road Materials).

The *consistency* of asphalt may be determined by ductility tests.¹ No standards have as yet been established, the test being not generally undertaken.

The *melting point* of asphalt is about 50° C. and is varied by the amount of flux or lighter oil it contains.

The *volatility* of asphaltic mixtures is an index of their value in actual service. The loss which an asphaltic material suffers and the nature of the residue left may both be determined in this test.

CHEMICAL NATURE OF ASPHALT

The chemical composition of asphalt varies with the sources of its production, but in general it consists of a mixture of hydrocarbons together with oxygen, sulphur, and nitrogen derivatives of the hydrocarbons. The hydrocarbons found in asphalt belong mainly to the polycyclic polymethylene, naphthalene and camphene series. The general term *bitumen* is applied to the mixture of hydrocarbon compounds contained in asphalt, and sometimes other hydrocarbons also.

Technically, the composition of asphalt is more important from the standpoint of its solubility in certain solvents. To ascertain the amount of total bitumen in a given sample, its solubility in carbon disulphide is determined. The residue generally consists of mineral matter and free carbon and the portion dissolved is the *total bitumen*. When an 86° Baumé naphtha obtained from a paraffin base petroleum is used as a solvent, only a portion of the asphalt goes into solution. The bitumen insoluble in this naphtha is called *asphaltene*, which is the portion of the asphalt that gives it adhesive properties and determines its power as a binding material. In the best asphalts, the asphaltene often occurs to the extent of 25 to 30 per cent. The constituents of asphalt which repre-

¹ See method in *Proc. Am. Soc. Testing Materials*, 9, 594 (1909).

sent the bitumen insoluble in carbon tetrachloride have been termed *carbenes*, and while little is known concerning their effect they are regarded as an indication of the use of too high temperatures in the refining and preparation of asphalt.

In the technical examination of asphalt considerable care and experience is required in order to keep within standard conditions. The interpretation of results from such an examination likewise requires a wide familiarity with the various classes of bituminous binders now on the market. These comprise residues from the distillation of petroleum, coal tar, and wood tar, together with mixtures and semi-solid materials of this type given in the following table taken from Hubbard: ¹

TABLE 39.—Analyses of Asphalts and Road Oils (Hubbard)

| | (Native Trinidad) | (Artificial California) | Gilsonite | Grahamite | California road oil | Blown oil |
|--|----------------------|----------------------------|-----------|-----------------|------------------------|-----------|
| Specific gravity 25° C. | 1.40 | 1.071 | 1.04 | 1.10 | 0.984 | 0.995 |
| Softens, degrees C. | 82° | | 127° | In- tumesces | | |
| Flows, degrees C. | 88° | | 135° | " | | |
| Penetration at 25° C. | 7° | 52° | 0° | 0° | | 193° |
| Loss at 163° C., 7 hours p. ct. | 1.0 | 2.7 | 0.4-0.7 | 0.1 | 16.4 | 0.00 |
| Loss at 205° C., 7 hours " | 4.0 | | 1-2 | 0.5 | 30.0 | |
| Bitumen soluble in CS ₂ | 56.5 | 99.7 | 99.5 | 96.0 | 99.7 | 99.71 |
| Bitumen insoluble in 88° naphtha | " | 37.0 | 27.8 | 46.0 | 96.5 | 9.8 |
| Bitumen insoluble in CCl ₄ | " | 1.3 | 6.0 | 0.4 | 55.0 | |
| Organic matter insoluble " | 7.0 | 0.3 | 0.5 | 0.2 | 0.12 | 0.20 |
| Inorganic matter | " | 36.5 | Trace | 0.0 | 3.8 | 0.11 |
| Fixed carbon. | " | 11.0 | 18.8 | 14.0 | 40.0 | 2.05 |
| | | | | | | 11.8 |

¹ Dust Preventives and Road Binders, pp. 105-111.

COAL TAR

The use of various grades of coal tar is becoming more frequent for paving purposes during recent years and, since the supply of tar is as great as that of asphaltic oils, it will no doubt compete with asphaltic preparations. Crude coal tar is a product of the gas works and is also obtained in the manufacture of coke. When coal tar is subjected to a refining process by fractional distillation the following products are obtained:

1. Below 105° C. water, ammonia, and first light oils.
2. From 105° C. to 210° C., second light oils.
3. From 210° C. to 240° C., carbolic oils.
4. From 240° C. to 270° C., heavy or creosote oils (dead oil).
5. Above 270° C., anthracene or green oil.
6. Residue, tar pitch.

From the light oils, benzol is obtained, from the carbolic and creosote oils, carbolic acid and naphthalene are made; and anthracene is the chief constituent of the green oil.

The coal tar pitch is a thick viscous liquid when hot and may be soft, medium, or hard when cold. It is graded upon its relative hardness, or softness, which in turn depends upon the extent to which the dead oils have been removed. It is composed largely of bitumen and represents the binding base when used as a road material.

The properties of coal tar pitch are not very specifically defined. In England the following limitations are placed upon it: (1) it must yield no matter volatile below 270° C. when subjected to dry distillation; (2) its total organic matter must not fall below 30 per cent; (3) not more than 80 per cent of its weight should be insoluble in petroleum naphtha (sp. gr. 0.70); (4) it must be free from extraneous matter, such as sand; and (5) it must twist fairly well after immersion in water at 60° F. but not under 55° F.

REFERENCES

I

- BOORMAN: Asphalts.
HUBBARD: Dust Preventives and Road Binders.
JUDSON: City Roads and Pavements.
JUDSON: Road Preservation and Dust Prevention.
KUMMER: Modern Wood Pavements.
PECKHAM: Solid Bitumens.
RICHARDSON: The Modern Asphalt Pavement.
TILLSON: Street Pavements and Paving Materials.

II

- PECKHAM: Asphaltum for a Modern Street. *Pop. Sci. Mo.*, **58**, 225 (1901); **61**, 212 (1902).
PARR, MEARS AND WEATHERHEAD: The Chemical Examination of Asphaltic Material. *J. Ind. Eng. Chem.*, **1**, 751 (1909).
FRANKFORTER: Studies in Asphalt. *J. Ind. Eng. Chem.*, **2**, 239 (1910).
MANN: Testing of Coal Tar Creosote. *J. Soc. Chem. Ind.*, **29**, 732 (1910).
RICHARDSON: A Solid Native Bitumen. *J. Am. Chem. Soc.*, **32**, 1032 (1910).
SOMMER: Methods of Asphalt Examination. *J. Ind. Eng. Chem.*, **2**, 181 (1910).
TAYLOR: Treating Timber with Crude Petroleum. *Eng. News*, **63**, 132 (1910).
New Specifications of Association for Standardizing Paving Specifications. *Good Roads*, **12**, 234; *Chem. Abs.*, **5**, 2551 (1911).
New Specifications of Board of Local Improvements of Chicago for Creosoted Wood Block Pavement. *Chem. Abs.*, **5**, 3508 (1911).
ALLEN: Recommended Specifications for Bituminous Materials. *Eng. Rec.*, **64**, 200 (1911); also *J. Soc. Chem. Ind.*, **30**, 670 (1911).
CHERRINGTON: Asphaltic Oils as Economical Wood Preservers. *Municipal Eng.*, **40**, 411 (1911).
CHURCH: Methods for Testing Coal Tar, Oils and Pitches. *J. Ind. Eng. Chem.*, **3**, 227 (1911).
CHURCH: Recent Publications on Creosote Oils. *J. Soc. Chem. Ind.*, **30**, 191 (1911).
FORREST: Characteristics of Creosote and Tar Oils Available for Wood Preservation. *J. Soc. Chem. Ind.*, **30**, 193 (1911).

- LOHMANN: Technical Analysis of Petroleum Asphalt. *Chem. Ztg.*, **35**, 357 (1911).
- SAGE: Testing of Creosote. *J. Soc. Chem. Ind.*, **30**, 588 (1911).
- SOMMER: Trinidad Asphaltic Petroleum and its Use as a Road Material. *Eng. Rec.*, **64**, 24 (1911).
- WEISS: The Antiseptic Effect of Creosote Oil Used for Preserving Wood. *J. Soc. Chem. Ind.*, **30**, 1348 (1912).
- WEISS: Tests to Determine the Commercial Value of Wood Preservatives. *Proc. 8th Intern. Congr. Appl. Chem.* **13**, 279 (1912).
- CHURCH: Specifications for Creosote Oils. *Eng. Rec.*, **65**, 80 (1911-12).
- GRAEFE: Production of Trinidad Asphalt. *Chem. Ind.*, **35**, 175 (1912).
- RICHARDSON: Trinidad and Bermudez Asphalts. *Pop. Sci. Mo.*, **81**, 1 (1912).
- DEAN AND DOWANS: Antiseptic Tests of Wood Preserving Oils. *J. Ind. Eng. Chem.*, **5**, 126 (1913).
- HEWES: Repair and Maintenance of Highways. U. S. Dept. Agriculture, Office of Public Roads, Bull. 48 (1913).

CHAPTER XIV

PAINT AND VARNISH MATERIALS

THE annual consumption of paints and varnishes in the United States exceeds \$200,000,000. This expenditure represents a variety of products which serve to decorate, protect, and preserve wooden, metallic, concrete, and wall surfaces.

The classification of the materials used in paint and varnish manufacture is somewhat difficult on account of their great variety, but the following is proposed:

I Paint pigments,

A Natural,

B Chemically manufactured,

II Paint vehicles,

Linseed oil,

Raw,

Boiled,

Chinese wood oil,

Soya bean oil,

Fish oil,

Turpentine,

Gum,

Wood { Steam distilled,
Destructively distilled,

Benzol (benzene),

Petroleum oils,

III Paint driers,

Inorganic lead and manganese compounds (oil driers),

Organic liquid driers (Japan driers),

- IV Varnish resins,
 - For oil varnishes,
 - For spirit varnishes,
- V Bituminous materials,
 - Asphaltum varnish,
 - Asphaltum enamel,
 - Tar enamels.

Paint may be defined as a mixture of opaque or semi-opaque substances (pigment) with liquids (vehicles) which may be applied to surfaces by brushing or dipping, and which on drying form an adherent coating on such surfaces. The function of such a coating is either to beautify or protect the surface to which it is applied or in many cases to accomplish both purposes.

PIGMENTS

The natural pigments used in paint manufacture occupy a relatively unimportant place, less than 70,000 tons being used annually in the United States against over 250,000 tons of those chemically manufactured. The natural pigments which find application in paint manufacture go under the following names: ocher, sienna, umber, metallic paint, mortar colors and the so-called inert pigments, including barytes, silica, asbestos, china clay, gypsum and calcium carbonate.

Ocher, *sienna*, and *umber* are natural compounds which have for their main constituent hydrated oxide of iron, known as limonite. Sienna and umber have a darker color than the yellow ocher due to the presence of manganese and organic matter. *Metallic paint* and *mortar colors* are red and brown iron oxide, produced either by grinding the mineral found in the natural state or by roasting iron carbonate. The iron oxide thus employed together with a number of similar oxides produced by manufacturing processes (for example, when iron sulphate is treated with lime water and the re-

sulting precipitate oxidized in a furnace, *Venetian red* is obtained) are known as the natural earth colors.

The inert pigments in common use are likewise natural products but are generally subjected to certain refining processes before they can be used in paints. *Barytes* is the chemical compound barium sulphate (BaSO_4), and goes under various names as blanc fixe, permanent white, etc. It is found as a natural product, usually in association with lead and zinc ores. To render it suitable for pigment purposes it is finely ground, thoroughly washed with acids and separated into various grades by water floating. *Silica* (silex, silicious earth), is the chemical compound silicon dioxide, (SiO_2). It exists in many forms, such as quartz, rock crystal, flint, and diatomaceous (infusorial) earth. When made from quartz it is usually disintegrated by heating and dropped into cold water, after which it is finely ground and separated by water floating or air separation (q. v.). *Diatomaceous* or *siliceous* earth is usually heated to remove organic matter and bolted or air separated. Asbestos and talc are both silicates of magnesium, which usually contain water of hydration. For use as a pigment the mineral forms are purified and finely ground and go under the general name of *asbestine*. *China clay* or *kaolin* is a hydrated silicate of aluminum and is often spoken of (incorrectly) as alumina. Finely ground *feldspar* is also often used for pigment purposes. Gypsum as a pigment is generally obtained from deposits where it occurs in its hydrated form ($\text{CaSO}_4 \cdot 2\text{H}_2\text{O}$), but the transparent selenite and translucent alabaster are also employed. This pigment is sometimes known under the term *terra alba*. Calcium carbonate, as a pigment is variously known as *whiting*, *Paris white*, or *white mineral primer*, and is made by grinding, washing, and floating marble, chalk, calcite and certain types of dolomite. Mineral primer is usually made from the latter and therefore contains magnesium carbonate in its composition.

CHEMICALLY MANUFACTURED PIGMENTS

The pigments described under this head may be divided in those constituting the white bases, the chemical colors, pigment lakes, and the carbon blacks. The principal white bases are zinc oxide, white lead, sublimed white lead, and lithopone. A brief description of the manufacturing processes employed for each will be given.

Zinc oxide (ZnO), is made either from metallic zinc by burning the latter in a current of air and collecting the product of combustion, zinc oxide, in chambers or dust collectors, or by burning in a closed furnace a mixture of zinc ores and fine coal and collecting the zinc oxide in a series of cooling flues and dust collectors. The former is known as the French process and the latter as the American process. Zinc oxide is the most finely divided of all white pigments and is the whitest in color. On account of its extreme fineness and relative lightness it requires more oil than other white pigments, each one hundred pounds of zinc oxide paint requiring about forty-six pounds of oil and fifty-four pounds of pigment. It is unaffected by the gases usually present in the atmosphere and is not poisonous.

Basic carbonate of lead or **white lead** is one of the principal pigments chemically manufactured. The Dutch process is largely employed in the original or modified form. This consists in converting pure metallic lead into basic lead acetates which are in turn acted upon by carbon dioxide to form basic carbonate of lead, or white lead. In the old Dutch process, spent tan, earthenware pots containing acetic acid and perforated disks or buckles of lead, a layer of wood boards, successively piled above each other, constitute a stack. The fermentation of the tan develops heat and carbon dioxide, vaporizing the acetic acid, which acts on the lead. The reactions represented by this process are

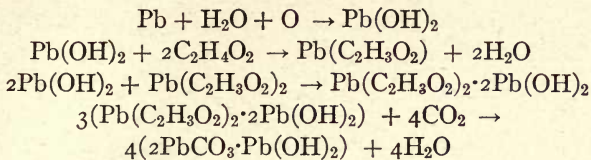

The basic carbonate of lead is next crushed, screened, water floated, ground in water, and dried; this constitutes the white lead of commerce. The white lead produced by the Dutch process is not of constant composition, varying between 60 to 80 per cent of lead carbonate and 17 to 38 per cent lead hydroxide. It mixes readily with linseed oil, works easily under the brush and seems to increase the drying properties of linseed oil.

In the modified processes the lead in the first step is generally "atomized" by superheated steam or otherwise finely divided. The carbon dioxide from the combustion of coke under boilers is generally employed, thus quickening the reaction and shortening the process. The white lead thus produced is known under the name of "quick process" lead and is finer in texture than the "stack" lead of the Dutch process. In one form of this process (Dahl lead) the lead is precipitated from solution by carbon dioxide. It is in an amorphous condition and is characterized by its great fineness. "Mild process" lead is made by the successive action of moisture, air, and carbon dioxide gas. The lead is first finely atomized by superheated steam as in the "quick process" and is next fed into cylinders and agitated in water through which a current of air is passed. This converts the metallic lead into lead hydroxide and upon being further agitated in cylinders of water in the presence of a stream of carbon dioxide, the basic lead carbonate is precipitated and prepared as above described.

Sublimed white lead differs in composition from the preceding lead pigments, being an oxysulphate of lead of the following approximate composition:

| | |
|------------------------|-------------|
| Lead sulphate. | 75 per cent |
| Lead oxide. | 20 per cent |
| Zinc oxide. | 5 per cent |

It is made from lead sulphide ores by the action of heat from the fuel, which volatilizes and oxidizes the lead sulphide. In this condition powerful suction fans carry the vapors through a long series of sheet iron pipes or flues, the condensed and cooled white vapors being finally collected in fabric condensers. It is claimed that sublimed white lead, in addition to being finer than the basic carbonates, is less poisonous and resists the discoloring action of hydrogen sulphide longer than other lead pigments.

Lithopone consists of an intimate mixture of zinc sulphide and barium sulphate produced by the interaction of solutions of zinc sulphate and barium sulphide. By using concentrated solutions at a certain temperature and properly mixing a precipitate is obtained which may be readily filtered. In this condition, however, it is not suitable for pigment purposes and accordingly it is heated in muffles at 500° C., suddenly plunged into water, ground, washed, and dried. This yields a pigment which is very fine, amorphous, and characterized by its great opacity and whiteness. Its use is, however, limited to interior surfaces since sunlight turns it gray and thus causes discoloration.¹ Lithopone often contains a small percentage of zinc oxide due to the decomposition of zinc sulphide by heat.

The chemical colors are pigments formed by chemical reactions. They are used to impart some characteristic color to the surface to which they are applied, in addition to the principal function of an ordinary pigment, i. e., its covering property and opacity. A large variety of pigments of this type are manufactured, the principal ones being Prus-

¹ For a discussion of the photogenic qualities of zinc sulphide see Toch: Chemistry and Technology of Mixed Paints, page 28.

sian blues, chrome yellow, chrome green, red lead, orange mineral.

Prussian blue is made by the precipitation of iron ferrocyanide from solutions of potassium ferrocyanide and some soluble iron salt. *Chrome yellow* consists of lead chromate obtained by precipitation from solutions of a lead salt by a soluble chromate. *Chrome green* is a mixture of Prussian blue and chrome yellow. *Red lead* is prepared by converting metallic lead into lead monoxide, PbO , known as litharge, in a reverberatory furnace and then "coloring" or further oxidizing from the monoxide to red lead, Pb_3O_4 . *Orange mineral* is produced by the oxidation of white lead in reverberatory furnaces. It differs from red lead in being amorphous in structure and in having a lighter but more brilliant color.

The pigment lakes may be defined as dyestuffs (organic compounds) which are in combination with mineral bases, such as aluminum hydroxide, barium sulphate, iron oxide, whereby the dyestuff is rendered insoluble in water. Frequently the dyestuff itself is precipitated by such precipitants as barium chloride, lead acetate, tannic acid, the mineral base acting as the carrier for the color. Very many lakes are now manufactured but the ones most extensively used for pigment purposes are those that come under the general head of the "para" reds. A brief discussion of the method of production of this class may serve as an illustration of this kind of pigments.

The *para reds* belong to the class of compounds known as the azo dyes and are made by the diazo reaction, which is typical of certain organic compounds.¹ When, for example, paranitraniline ($C_6H_4NO_2NH_2$), is dissolved in hydrochloric acid and is then acted upon by sodium nitrite in the cold, a compound containing the azo nitrogen

¹ The student is referred to any text-book of organic chemistry for a discussion of the diazo reaction and the diazonium compounds.

group, N:N, is formed as indicated in the following reaction:

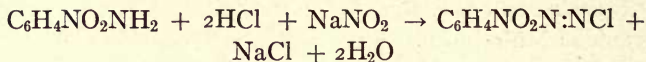

The resulting diazo compound, which is para-nitro-benzene-diazo-chloride, is not a dye and is a very unstable body, being readily decomposed by heat, light, and chemical reagents. Accordingly, when treated with an alkaline solution of a phenol, such as beta-naphthol, $\text{C}_{10}\text{H}_7\text{OH}$, the chlorine is displaced and the phenol takes its place as represented in the following reaction:

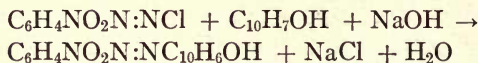

The resulting azo compound is known as para-nitro-benzene-azo-beta-naphthol and is a colored compound which is insoluble in water. This compound, or compounds similarly formed, constitute the "para" reds which are characterized by a powerful coloring action, since pigments which go under this name often contain as little as 5 per cent of "para" red, the remainder consisting of mineral bases such as barytes, zinc oxide, etc.¹

The carbon blacks, which are composed of pure carbon, are used in a variety of forms. They comprise lamp black, which is soot; graphite, which is either a natural product or is artificially produced from bituminous substances by means of the electrical furnace; bone black made from animal matter by carbonization; and mineral black, which is a finely ground black slate. Carbon black was the name formerly applied only to the soot obtained by burning natural gas, acetylene, paraffin oil, etc., but the name has in actual practice been made to cover the forms named as a class rather than as any distinctive kind.

¹ Toch: Chemistry and Technology of Mixed Paints, p. 44.

PAINT VEHICLES

In the preparation of paints the vehicle is by far the most important thing to consider. While the pigment requires careful consideration, the chemistry of pigments is pretty thoroughly worked out, and their properties and characteristics are therefore well known. The oils used for vehicles have not been as satisfactorily studied and their proper use is sometimes rather uncertain.

The oils which serve as vehicle (as distinguished from thinner) in paints are fatty oils obtained from animal and vegetable materials and consist of mixtures of the glycerides of fatty acids. In order to give good service in paint they must be of the nature known as "drying" oils; that is, when spread in a thin layer and exposed to the atmosphere they absorb oxygen, lose their fluidity, and become tough, elastic solids. Those oils used in paints which do not have this property but evaporate when exposed to the atmosphere function merely as "thinners," facilitating both the penetrating and the spreading power of a paint. Linseed oil as vehicle and turpentine as thinner are the standard materials though in many cases it is possible to make use of cheaper oils to a greater or less extent.

"Constants" of Oils.—The analysis of an oil for the purpose of ascertaining its nature as an oil and for comparison with other oils does not involve the actual determination of its constituents, but instead it is a quantitative measure of certain chemical and physical properties which serve to characterize the oil and to indicate that it is suitable or detrimental, as the case may be, for specific uses. The properties which thus serve to characterize the oils are commonly referred to as "constants," although in reality they are subject to measurable variation as between different pure specimens of the same kind of oil. The physical "constants" are the quantitative expression of such physical properties as

specific gravity, index of refraction, freezing or solidifying point, flashing point (flash test), and burning point (fire test). The chemical "constants" are quantitative numbers dependent upon the relative amounts of the different fatty acids which are present in the oil, to a small extent in the free state but chiefly as glycerides. For discussion of the significance of these constants and the methods for their determination and interpretation, the reader is referred to Sherman's *Methods of Organic Analysis*, Revised Edition, Chapters VIII-X. The three chemical "constants" which are included in the standard for linseed oil to be given below may be briefly defined as follows:

The saponification number is the number of milligrams of potassium hydroxide consumed in the complete saponification (i. e., complete neutralization of total fatty acids, whether free or in the form of esters) of 1 gram of the oil. This number aids the judgment as to whether the sample contains any other than fatty oils, and in a sample consisting of fatty oils only it indicates the mean molecular weight of the glycerides and therefore of the fatty acids present.

The acid number of an oil is the number of milligrams of potassium hydroxide required to neutralize the free fatty acids in 1 gram of substance. It is therefore an indication of the amount of acid present in the oil in a free state. The difference between the saponification number and the acid number is the "ester number," or the amount of alkali consumed in the saponification of esters. In the case of a fatty oil, the esters are of course glycerides.

The iodine number is the percentage of iodine absorbed by the sample. This number gives a quantitative measure of the presence of unsaturated fatty acid radicles (or the "number of double bonds") in an oil. Since the unsaturated compounds are quite reactive toward oxygen as well as toward iodine, this property is, in a general way, taken to be a

measure of the readiness with which oils will change upon exposure to the atmosphere or "dry" into a film or membrane.

Linseed oil constitutes the chief paint oil. It is pressed from the seeds of the flax plant which is produced in large quantities in North and South America, Russia and India. In America flax is raised almost exclusively for its seed, labor being too high to permit of the economical utilization of the fiber. The seeds are crushed between rollers, then heated to 160° F. and pressed while warm. The crude fatty oil thus obtained contains as impurities small amounts of water, mucilage, protein, and coloring matter. To remove these impurities it is refined by keeping it in tanks for five or six months, or the oil may be heated for a shorter time, washed, and treated with a little sulphuric acid, which carbonizes and precipitates the protein and coloring matter, leaving the oil with a light yellow color, characteristic odor, and sweet taste.

The "constants" which should be expected of linseed oil for use in paint, together with the length of time required for the oil to "dry" on glass under prescribed conditions, are given by the United States Bureau of Chemistry (Bulletin 109) as follows:

| | |
|-----------------------------------|-----------------|
| Specific gravity at 15.5° C. | 0.932 to 0.936 |
| Flash point (open cup). | 240° to 250° C. |
| Fire point. | 290° to 300° C. |
| Drying on glass. | 3 to 4 days |
| Acid number. | 2 to 6 |
| Saponification number. | 189 to 190 |
| Iodine number. | 178 to 186 |

The drying properties of linseed oil are increased by the process known as "boiling," and the oil which has been thus treated is called boiled linseed oil. The boiling process consists in heating the oil with small quantities of lead or manganese compounds. The heating may be done over an open

fire or in a steam jacketed pan provided with air agitators. Boiled linseed oil is more viscous than raw oil, its color varies from pale yellow to reddish brown, and its drying property is improved so that it will dry in 24 hours or less, instead of three or four days. The constants of a typical boiled oil are given by Sabin ¹ as follows:

| | |
|--------------------------------|--------|
| Specific gravity at 15.5°..... | 0.9385 |
| Saponification number..... | 190.6 |
| Acid number..... | 4.2 |
| Iodine number..... | 180.4 |

The so-called "constants" are subject to rather more variation in the case of the boiled than of the raw oil.

Owing to the limited supply of linseed oil, numerous attempts have been made to substitute other oils for a paint vehicle. Among the oils more or less successfully used in this manner are Chinese wood oil and soya bean oil, both of which are produced in the Orient in large quantities, and fish oil obtained chiefly from the Menhaden of the Atlantic Coast.

Chinese wood oil or tung oil is obtained from the nuts of the Chinese tung tree. The constants of a typical sample were as follows:

| | |
|--------------------------------|---------|
| Specific gravity at 15.5°..... | 0.941 |
| Acid number..... | 4.4 |
| Saponification number..... | 190.9 |
| Iodine number..... | 169-171 |

Before Chinese wood oil can be used as a paint or varnish oil it requires heat manipulation or chemical treatment since, if used in its raw state, while it dries quickly and seems to set or harden uniformly, it forms a wax-like opaque and wrinkled film which has but little adherence to the surface to which it

¹ Technology of Paint, p. 67.

is applied. By heating the wood oil to elevated temperatures (400 to 550° F.) it loses this objectionable characteristic and is converted into a product which dries with a high gloss and with a smooth even film which is tough and elastic and has great adherence to the surface. However, when wood oil alone is heated to the above temperature, it will suddenly gelatinize, or become solid, and neither subsequent heating nor addition of ordinary solvents will reduce it to liquid form. In order therefore to render Chinese wood oil satisfactory, it is necessary to heat it and at the same time add some substance to prevent it from gelatinizing during the heating. According to Toch ¹ this substance is an organic salt of lead and manganese. In the author's experience ordinary hardened rosin (i. e., resinates of lime) has proved very satisfactory in the preparation of Chinese wood oil for use as a vehicle. For this purpose rosin is first melted, after which calcium hydroxide (hydrated lime) is added and the temperature raised sufficiently to cause complete reaction between the lime and the rosin to take place. The raw Chinese wood oil is then added and a temperature of 450 to 550° F. (223 to 288° C.) maintained for some time until the desired "body" or consistency is obtained, after which it may be thinned down by the use of turpentine or petroleum oils in the paint or varnish in which it is employed.

Chinese wood oil has found numerous applications in the production of flat finish wall paints and as a general vehicle used in conjunction with linseed oil.

Soya bean oil has recently been imported into the United States in large quantities. It is produced from the Manchurian soya bean and possesses a close resemblance to linseed oil in its physical characteristics. The crude oil possesses a darker color and a slightly more acid taste than linseed oil. Its constants as determined in the author's laboratory are as follows:

¹ Chemistry and Technology of Mixed Paints, p. 101.

| | <i>Raw oil</i> | <i>Cleared oil</i> |
|------------------------------------|----------------|--------------------|
| Specific gravity at 22° C. | 0.934 | 0.953 |
| Solidifying point. | -8° to -25° C. | -5° to -10° C. |
| Acid number. | 1.92 | 6.63 |
| Saponification number. | 192 | 190.9 |
| Iodine number. | 121 to 130.7 | 116 to 122 |
| Flash point. | 238° C. | 258° C. |
| Fire point. | 305° C. | 310° C. |

The process of clearing soya bean oil consists in blowing a current of hot air at 200° C. through the oil for a number of hours and filtering the product through fullers' earth. This yields an oil of lighter color and sweeter taste than the raw oil. When used with the usual driers and in conjunction with linseed oil it has proved a very desirable vehicle in a number of paints.

Fish oil.—The oils expressed from the menhaden, a fish native to the waters of the Atlantic, and from the salmon and herring of the Pacific and Alaskan coasts, have recently found application in paint manufacture. These oils vary in chemical composition with the species from which obtained, manner of expression, and the extent to which they have been refined. The usual objections advanced against fish oils are slowness of drying and the foul odor. The former is overcome by the use of driers usually made from Chinese wood oil, while the odor may be removed by passing a current of air heated to 250° C. through the oil for a number of hours and then filtering the oil through a calcareous clay. This treatment leaves the oil with a slight characteristic odor which may be rendered unobjectionable by adding one-half of one per cent of its weight of some oxidized terpene, such as terpineol, which is a constituent of the pine¹ and fir oils.²

¹ Teeple: *J. Am. Chem. Soc.*, **30**, 412.

² Benson and Darrin: *J. Ind. Eng. Chem.*, **3**, 818 (1911).

Fish oils used in paints generally show constants approximating those of linseed oil, except that the iodine number is generally lower; it should not be less than 150. It is claimed by Toch and other authorities that mixtures of linseed and fish oils improve the waterproofing properties of the paints in which they are used, as well as being more resistant to heat than pure linseed oil and are therefore suitable for use on heated surfaces, such as smokestacks, boiler fronts, etc.

Turpentine is to be regarded as a diluent of the vehicle which is usually desirable, causing it to become thinner, increasing its spreading or flowing property, and rendering the paint more easily workable under the brush. Turpentine is a mixture of various terpenes ($C_{10}H_{16}$) obtained from the sap of the pine tree and from steam distillation of the wood of Norway and Southern pines and of Douglas fir.

Pure gum turpentine is the product of "boxing," which is the name given to the means used to collect the oleo resin, or so-called "gum." The latter as collected contains as impurities variable amounts of water, chips, bark, pine needles, and earth. The crude gum is poured into a copper still and, upon heating, a mixture of water and turpentine passes through the condenser and collects in a separator box where the water settles to the bottom and the turpentine is drawn off. After the heating has boiled off most of the water, steam is introduced, and the process of distillation proceeds at a temperature below 150° C., leaving a residue of rosin in the still.

Wood turpentine is obtained by the action of steam on wood chips which contain the oleo resins. For this purpose steam stills are employed and after the turpentine has been distilled and collected in separators, the chips are treated with a suitable solvent, such as solvent naphtha, 86° gasoline, and the rosin dissolved. The rosin afterwards is recovered from this solution by evaporation and recovery of the solvent.

Destructively distilled wood turpentine is one of the prod-

ucts obtained from the destructive distillation of resinous woods and may be readily distinguished from gum turpentine by the characteristic odor of burnt wood, as well as by the darker color.

The following shows the constants usually determined in the examination of turpentine, the data being taken from Bulletin No. 135, Bureau of Chemistry, United States Department of Agriculture.

| | <i>A</i> | <i>B</i> | <i>C</i> | <i>D</i> | <i>E</i> | <i>F</i> |
|--|----------|----------|----------|----------|----------|----------|
| Specific gravity at 20° C. | .8617 | .8989 | .8771 | .8630 | .8676 | .8543 |
| Refractive index at 20° C. | 1.4684 | 1.4818 | 1.4733 | 1.4710 | 1.4696 | 1.4659 |
| Initial distilling temperature °C. | 154.5 | 159.0 | 158.0 | 162.0 | 156.0 | 157.0 |
| Per cent distilling below 165° C. | 68.8 | 98.6 | 56.7 | 18.0 | 95.0 | 57.0 |
| Per cent distilling below 170° C. | 77.3 | 99.1 | 80.2 | 71.0 | | 73.9 |
| Polymerization percentage of residue | 0.2 | 1.0 | 0.8 | 1.0 | 0.1 | 12.4 |
| Refractive index of polymerization residue | 1.500 | 1.5150 | 1.5005 | 1.5055 | | 1.4374 |

A.—Minimum limits of gum turpentine.

B.—Maximum limits of gum turpentine.

C.—Wood turpentine from Louisiana.

D.—Destructively distilled wood turpentine.

E.—Wood turpentine from Douglas fir, obtained by steam distillation analyses made in author's laboratory.

F.—Turpentine for industrial purposes, which has been adulterated with 12 per cent mineral oil.

Adulteration of turpentine is practiced to a considerable extent, the authors of Bulletin No. 135 above quoted, showing that in 1908 about 18 per cent of the consumption, or over 3,000,000 gallons of turpentine, were adulterated with mineral oil. Deodorized gasoline and kerosene are the usual

adulterants, and it is possible to mix petroleum products with turpentine so that neither the specific gravity, refractive index, nor flash point is altered. The detection of mineral oil is almost entirely based upon the polymerization test.¹

Benzene, C_6H_6 (also called benzol), is obtained from the distillation of coal tar and in its crude form is often known as light oil of coal tar. Pure benzene has a boiling point of $82^\circ C.$ and is characterized by its great solvent power for gums and resins. The crude light oil of coal tar is refined for use in the paint industry into various commercial solvents which usually contain mixtures of benzene, toluene, and xylene. One of the most widely used oils of this type is known as solvent naphtha, and represents that distillate of light oil of coal tar which boils between $130^\circ C.$ and $160^\circ C.$ It is sometimes also described as "160° benzol." These coal tar products in paint vehicles serve as thinners of the vehicle, being similar to turpentine, inasmuch as they produce greater spreading power and in addition facilitate the penetration of the oils into wooden surfaces, thus producing a firmer union of the paint film with the surface.

The petroleum oils chiefly employed as paint thinners are benzine (i. e., gasoline of 62° to 66° Bé'), petroleum distillate, kerosene oil, "turpentine substitute," and "neutral oil." The latter is a heavy-bodied oil, often used as a substitute for linseed oil for grinding colors into a paste form. Turpentine substitute is made usually by passing paraffin oils over heated coke in conjunction with wood turpentine or otherwise "cracking" heavy hydrocarbon oils into lighter oils. The other petroleum oils mentioned are used as thinners or volatile solvents for vehicles and gums respectively. Considerable prejudice exists against the use of petroleum products in paints and it may be of interest to consider again the function of the volatile oils used in conjunction with paint vehicles and in varnishes. As already intimated in the discussions on tur-

¹ See Bulletin 109, Bureau of Chemistry, U. S. Dept. of Agriculture.

pentine and benzene, the effect is purely mechanical and temporary. The volatile oils, or thinners, however, aid not only in the spreading power of an oil, but by means of their rapid evaporation, hasten the "setting" of the paint, assist in the penetration of the priming coats into the pores of the wood, as well as reduce the gloss of the priming coats, and thus form a better bond for subsequent coats. Viewed in this light the source of the volatile oil is largely immaterial and the selection of a particular oil to perform the functions enumerated is rather a matter of degree than of the kind of oil to be used.

PAINT DRIERS

The drying of linseed oil has formed the subject of extensive researches.¹ Drying oils may be regarded as being mixtures of glycerides of which some at least of the fatty acids are highly unsaturated, containing two, three, or possibly sometimes even four "double bonds" to one fatty acid radicle. In the case of linseed oil the acid with two "double bonds" is linoleic ($C_{18}H_{32}O_2$) and that with three double bonds (or perhaps a double and a triple bond) is linolenic ($C_{18}H_{30}O_2$). On exposure to air, oxygen is absorbed, resulting in the oxidation of some of the unsaturated fatty acid radicles of the glycerides and the production of a compound known as linoxyn. This product is distinguished by great elasticity. It is insoluble in water, but readily saponifies with potash. It is less soluble in ether and more soluble in alcohol than the oil from which it is formed. To hasten the formation of this hard elastic compound certain substances known as driers are introduced into the oil.

The exact manner in which driers act upon linseed oil is not known. It is thought that the oil first acts upon the drier by taking up its oxygen and that the drier in turn is

¹ See *Journ. Ind. Eng. Chem.*, 3, 84; also Böttler-Sabin: German and American Varnish Making.

oxidized by the air. Driers are thus considered to be the carriers of oxygen and act as catalyzers. That the action should be regarded as a catalytic one seems reasonable since less than 1 per cent of drier is usually required.

For convenience the classification of driers is based upon their solubility in turpentine and, while many combinations of the two classes are possible, we can distinguish a clear dividing line on the basis mentioned.

Inorganic Lead and Manganese Compounds (Oil Driers).—The lead compounds used as driers are litharge, lead borate, lead acetate and red lead. The principal manganese compounds used as driers are the dioxide, acetate, sulphate, and borate. To prepare the borates, lead acetate, or manganous sulphate, is added to a solution of borax and the corresponding metallic borates are filtered and dried. The inorganic lead and the manganese driers are both insoluble in turpentine and require a high temperature to dissolve in linseed oil. Driers of this type are often known as oil driers, since they are always used with linseed oil.

Liquid Driers (Japan Driers).—The driers of the second group, on the other hand, are soluble in turpentine and at ordinary temperatures also dissolve in linseed oil. This group is known under the general terms soluble driers, "terebenes" and soluble siccatives. The essential constituents of this group of driers are the resinates and linoleates of lead and manganese. Driers of this type constitute the so-called Japan driers.

Two general methods are available for the preparation of metallic resinates: (1) the solution of the metallic oxide in fused rosin and (2) the precipitation of metallic resinate from a solution of rosin soap by a solution of metallic salt. The latter process is also employed in the preparation of linoleates. Linseed oil is saponified with caustic soda and the resulting sodium salt dissolved in water. To this solution lead acetate or manganous chloride is added; precipitating lead

or manganese linoleate, which is separated from the liquid, washed with hot water, dried, and powdered. Mixtures of lead and manganese linoleate are often fused to a uniform mass and constitute lead-manganese linoleate. The soluble driers, accordingly may consist of (1) solutions of lead and manganese compounds dissolved at a high temperature in linseed oil (i. e., lead and manganese linoleates) and reduced to a thin consistency by turpentine and (2) solutions of lead and manganese resins in turpentine.

VARNISH RESINS

The general name of resin is given to the materials used in the manufacture of varnish. More especially they consist of (1) resins proper, (2) gum resins, (3) oleo-resins, and (4) artificial resins. *Resins proper* are of natural origin, found as exudations from a number of trees, and are either recent or fossil. They are generally hard, brittle, transparent, insoluble in water and soluble in alcohol, ether, benzene, and similar solvents. They are composed of oxygen derivatives of hydrocarbons with acid properties. The *gum resins* are mixtures of resins and gums. The gums are generally soluble in water and insoluble in alcohol. The *oleo-resins* are mixtures of resin and volatile oil, which causes them to be somewhat viscous in consistency. *Artificial resins* constitute a recent development in varnish manufacture of which Bakelite may be considered as a type.

VARNISHES

Oil varnishes are solutions of resins in linseed oil. Hence the particles of resin in the dried varnish are held together by the tough and elastic film formed in the oxidation of linseed oil. *Spirit varnishes* are solutions of resins in alcohol. On drying the alcohol volatilized and the dried varnish therefore consists of the evenly distributed resin in its unchanged form.

Such a surface is apt to be brittle and unsuited for wear unless protected by another coat of oil varnish.

Oil varnishes.—For the manufacture of oil varnish the hard resins, amber, copal, and Kauri “gum” are chiefly employed. *Amber* is often classed as a mineral since it occurs in thin plates and nodules disseminated in the sands, clays, and lignite of the Lower Tertiary formation. It is in reality a fossil resin formed from prehistoric conifers, vast forests of which flourished in the Cretaceous formation. It is the hardest resin known and fuses at about 290° C. *Copal* is found principally as a fossil resin in deposits and to a small extent as an exudation from trees now growing in Africa. It is known under a variety of names. *Animi* is the name given to the product mined in Zanzibar, while the fossil resins of the west coast of Africa are known as *copal*. *Kauri “gum”* is the name given to a fossil resin found in New Zealand, and Demarara copal to a fossil resin in South America. Copal in general melts at 205° to 240° C. and is insoluble in ether, benzene, and turpentine, except after melting, when it becomes soluble in hot linseed oil, turpentine, and benzene, but not in alcohol.

The process of manufacture consists in first melting the resin at as low a temperature as possible; next hot linseed oil is added and the mixture kept at a temperature of about 210° C. for some hours with constant stirring. After partial cooling turpentine is added to thin down to the desired consistency.

Spirit varnishes.—The resins chiefly used in the manufacture of spirit varnishes are dammar, shellac, mastic, sandarac, elemi, and rosin. *Dammar* is obtained from a species of pine growing in western Asia. It is brittle, melts at 260° F., and is soluble in turpentine, ether, benzene, and particularly in alcohol. *Shellac* is an incrustation found on certain trees growing in India. It is not a direct product of the tree, but is caused by the attacks of the lac insect, *Coccus*

lacca. In order to collect the incrustation the twigs of the tree are cut, the lac separated by rollers, thrown into warm water and kneaded, forming the crude lac. After boiling in hot water, the lac is dried, put into bags, and held in front of a hot fire. The lac melts, drains out, and drops into a wet revolving wooden cylinder, forming flakes known as shellac. Shellac has an orange or reddish color, and is partially soluble in alcohol and the ordinary solvents. It is bleached by the action of chlorine. *Mastic* is obtained from the trees growing on the coast of the Mediterranean Sea, *sandarac* from Africa, and *elemi* from the Philippine Islands. All are soluble in alcohol. *Rosin* or colophony is obtained from the oleo-resins of pine trees by the removal of the turpentine. Spirit varnishes are made by dissolving the resins in methyl, alcohol, benzene, or turpentine, by simply adding the solvent and shaking without application of heat.

The recent work of Baekeland has added an artificial resin known as *Bakelite*, to the list of varnish materials. Bakelite is a condensation product obtained by boiling molecular quantities of phenol and formaldehyde in the presence of sodium hydroxide. The nature of the reactions which take place when formaldehyde and phenol interact have been studied by Baekeland in detail and are described in his patents ¹ and other publications.² The preparation of Bakelite involves the utilization of three distinct and well defined stages, known as A, B, and C.

Bakelite "A," initial raw material, exists in liquid, pasty or solid condition. In all its forms (i. e., liquid, paste, solid) it is soluble in alcohol, acetone, caustic soda, and in general resembles a true resin.

Bakelite "B" is formed by the application of heat to "A"

¹ See U. S. Patents Nos. 939,966; 941,605; 942,699; 942,700; 942,808; 942,809; 942,852; 949,671; 954,666; 957,137; 982,230; 1,018,385; 1,019,406; 1,019,407; 1,019,408.

² *J. Ind. Eng. Chem.*, March, 1909, August, 1909, and December, 1911.

and is intermediate between "A" and "C." It is a solid product, infusible, and insoluble in all solvents. Heat tends to soften it without, however, bringing it into fusion. Some solvents, like phenol or acetone, cause it to soften or swell, without bringing it into solution. These properties enable its use in plastic compositions which have to be shaped or moulded into various forms.

Bakelite "C" is the final product resulting from the application of heat to "A" or "B." It is a solid product, infusible, and can withstand temperatures below 300°C . It is insoluble in all solvents and is unaffected by acids, oils, or steam. Although physically it resembles amber, it lacks all the chemical characteristics of a resin. Its chemical formula is represented by the formula $\text{C}_{43}\text{H}_{38}\text{O}_7$.¹

The material used for paint purposes is an alcoholic solution of "A" and resembles an ordinary spirit varnish, since in drying (i. e., evaporation of solvent) a thin coat of "A" is spread over the surface which has been painted by it. This film, like Bakelite "A," is fusible and soluble and has about the same hardness as shellac. It differs from the latter, however, inasmuch as it may be transformed by heat (while in place on the article in which it was used) into the "C" form, becoming infusible and insoluble.

BITUMINOUS PAINT MATERIALS

Paints for metallic surfaces subject to high temperature or for underground construction are largely of a bituminous nature. Paints of this character may be divided into three classes: (1) asphaltum varnish, (2) asphaltum enamels, and (3) tar enamels.

Asphaltum varnishes, as the name indicates, are solutions of solid bituminous substances in solvents which in drying volatilize, leaving a continuous film of solid bitumen on the

¹ *Trans. Am. Electro-Chem. Soc.*, 15, 593 (1909).

surface to which the varnish has been applied. In the manufacture of asphaltum varnish the principal bitumens employed are gilsonite, nanjak, grahamite, oil asphalt, and Bermudez asphalt. (These materials have been described in Chapter XIII.) The solvents generally used are turpentine, gasoline, kerosene, resin, and linseed oil. In other words, an asphaltum varnish is usually a mixture of a resin varnish and an asphaltum varnish. Copal and kauri resins are often added to impart a high gloss to the dried surface.

Asphaltum enamel consists of an asphaltum varnish and a pigment and may be of various colors. The selection of the pigment is dependent upon the uses and the colors desired.

Tar enamels are solutions of the residues obtained from the distillation of coal and wood tar. Considerable free carbon is formed and remains in suspension, acting in this way as a pigment and for this reason it is classed as an enamel. Benzene (benzol) is the usual solvent for coal tar pitch. For wood tar pitch other solvents like aniline, methyl alcohol and turpentine are required. The properties of the pitches used in tar enamels are as follows:

| | Coal tar pitch | Wood tar pitch |
|---|----------------|----------------|
| Specific gravity at 15° C. | 1.24 | 1.30 |
| Color of powder. | Black | Brown |
| Melting point. | 58° C. | 154° C. |
| Bitumen soluble in CS ₂ per cent | 94.1 | 81.78 |
| Ash. “ | 0.10 | 0.18 |
| Free carbon. “ | 5.8 | 18.23 |
| Bitumen soluble in 86° Bé naphtha “ | 85.0 | 0.00 |
| Fixed carbon. “ | 29.1 | 21.54 |

PAINTS FOR IRON AND STEEL

Two properties of paints used on metallic surfaces must be considered—(1) preservative and (2) protective. The object

of such paints is to prevent the corrosion of iron. A number of theories have been advanced to explain corrosion. The *carbonic acid theory* explains corrosion as a cyclic process: First carbonic acid acts on iron thus: $2\text{Fe} + 2\text{H}_2\text{CO}_3 \rightarrow 2\text{FeCO}_3 + 2\text{H}_2$. Next water and oxygen act on the ferrous salt producing rust according to the reactions: $2\text{FeCO}_3 + 5\text{H}_2\text{O} \rightarrow 2\text{Fe}(\text{OH})_3 + 2\text{H}_2\text{CO}_3$ and $2\text{FeCO}_3 + \text{O} \rightarrow \text{Fe}_2\text{O}_3 + 2\text{CO}_2$. The *peroxide theory* is based on the following reactions:

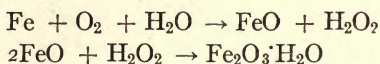

Both of these theories have been severely attacked from experimental evidence and the *electrolytic theory* is proposed to explain the phenomenon. This theory depends for its support upon the solubility of iron in pure water and the presence of hydrogen ions, the condition of equilibrium being expressed thus:

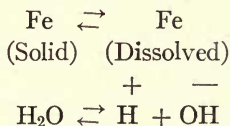

If the metallic surface, either from slight differences in composition or from different heat treatment, produces inequality of solution tension, a current of electricity flows and the positive hydrogen ions migrate to the negative areas and the negative hydroxyl ions to the positive areas. The effect of this migration is to charge the iron ions with the positive charge liberated by the hydrogen ion, with the consequent liberation of hydrogen gas. This action is precisely what occurs in other well known reactions, as for example:

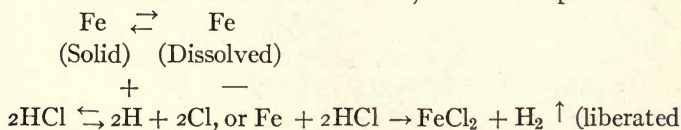

as gas) and $\text{Fe} + \text{CuSO}_4 \rightarrow \text{FeSO}_4 + \text{Cu} \downarrow$ (precipitated), hence the similar reaction: $\text{Fe} + 2\text{HOH} \rightarrow \text{Fe}(\text{OH})_2 + \text{H}_2$. The oxygen in solution oxidizes the ferrous hydroxide to the insoluble ferric condition; $\text{Fe}(\text{OH})_3$, is accordingly precipitated as rust, and the hydrolysis proceeds. A number of investigators, notably Whitney, Walker, and Cushman, have furnished experimental verification of this theory and its general acceptance seems probable. To prevent corrosion as viewed from this standpoint it is necessary to (1) induce polarization, or (2) induce passivity of the iron, or (3) prevent the formation of hydrogen ions by an increase of hydroxyl ions, or (4) exclude iron from contact with moisture by enveloping it with a waterproof coating.

To induce the formation of the so-called Helmholtz electrical double layer, *polarization*, it is proposed to employ a small electric current of such strength that the iron surface becomes insulated with hydrogen ions. The iron being negatively charged causes the hydrogen to deposit on it. This deposited hydrogen is a high insulator and its resistance to the flow of the current prevents the iron from going into solution. While attempts have been made to utilize this polarizing effect on a large scale the delicacy of the equilibrium makes it of doubtful expediency.

The *passivity* of iron is a state or condition in which it acts like platinum. When iron is dipped into strong oxidizing solutions, it has no longer the power of going into solution in dilute nitric acid, or of exchanging places with copper in a dilute solution of copper sulphate. Substances which have this power have accordingly been suggested for use as pigments. From the standpoint of corrosion, pigments may be classed as

1. Inhibitors, or rust preventing.
2. Indeterminates, inert.
3. Stimulators, or rust producing.

Among the common pigments the distribution is as follows:

| <i>Inhibitors</i> | <i>Indeterminates</i> | <i>Stimulators</i> |
|-------------------------------|----------------------------|--------------------|
| Zinc lead chromate | White lead (quick process) | Barium sulphate |
| Zinc oxide | Lithopone | Lampblack |
| Zinc chromate | Oregon mineral | Ocher |
| Chrome green | Red lead | Graphite |
| White lead (Dutch process) | Venetian red | (some forms) |

To bring about an *increase of hydroxyl ions* use has been made of a process known as the pickling of iron. Substances like the alkalis and salts of strong bases and weak acids yield a high concentration of hydroxyl ions, thus destroying the equilibrium of ionized water and removing hydrogen ions. In such solutions the iron suffers no corrosion. This method is, however, of very limited application and of no great industrial importance.

The exclusion of moisture from iron by means of *coatings* would seem to be the ideal method of preventing corrosion. The galvanizing of iron by zinc will, of course, save the iron at the expense of the zinc, on account of the high solution tension of the latter. If, on the other hand, a very low solution tension metal is used, such as tin, lead, and aluminum, better results may be obtained. Recent improvements in applying such metals in the molten condition as a spray make this method of some promise. The use of an oxidized surface for iron has proved satisfactory to a limited extent. This is accomplished by heating the iron to 800° or 1000° C. in a closed retort after which superheated steam, or mixtures of steam and carbon monoxide are injected, thus forming a magnetic oxide of iron, which is said to resist acid fumes and to be unaffected by solutions of copper sulphate.

More generally, however, iron is protected by paints. Their efficiency depends upon the nature of the pigment and the waterproofing properties of the vehicle. It is apparent that no rust stimulating pigment should be employed. Either the inhibitors or a mixture of indeterminates and strong

inhibitors should constitute the priming coat in contact with the steel surface. This coating constitutes the preservative agency, but to the priming coat should be added a protective coat.

The requisite qualities of a protective coating are its efficiency in excluding air and moisture, together with mechanical strength. According to Toch¹ linoxyn forms with moisture a semi-solid solution, and hence will conduct water through it to the metal. To overcome this tendency of moisture transmission, varnish resins are added to linseed oil, rendering the linoxyn film more resistant to moisture. Bituminous paints, on account of their electrical insulating properties would seem peculiarly well adapted for the protection of iron and are in fact largely employed. Experience has shown, however, their inability to weather under the action of sunlight, which produces a characteristic "alligatoring" or checking, similar to the crazing of vitreous glazes. The efficiency of a bituminous paint can be greatly improved by mixing with hard resins such as kauri or copal and by using properly refined bitumens.

In the manufacture of bituminous paints the residues obtained from the distillation of asphaltic oil, coal tar, and wood tar have proved serviceable. These residues when cold are solids which may be dissolved in various light oils and which on drying by evaporation deposit a uniform film of the pitch, of a high insulating value. Wood tar pitch has not been used on an industrial scale, but experiments² by the author show it to be of high merit as a protection to steel surfaces.

PAINTS FOR CEMENTS AND CONCRETE SURFACES

The diversity of uses for which Portland cement is employed has caused a demand for paints especially adapted to

¹ *J. Soc. Chem. Ind.*, May 31, 1905.

² *J. Ind. Eng. Chem.*, 3, 670 (1911).

the decoration or waterproofing of cement and concrete. The means employed to waterproof Portland cement include *integral* (i. e., mixed with the cements to form an integral part of the resulting mortar or concrete) and *coating* compounds. The latter are applied in the same manner as paints and often go under the name of cement paints. As has already been explained in Chapter XII, when Portland cement hardens, it forms a considerable quantity of calcium hydroxide. The effect of lime upon paints containing an oil, such as linseed, for example, is to saponify it and produce a soap, which, together with the oxidation that linseed oil constantly undergoes, causes gradual disintegration of the paints. To prepare the cement surface the Macnichol method of treatment has been recommended.¹ This consists in the application of a saturated solution of zinc sulphate to the cement surface. The chemical reaction which takes place is as follows:

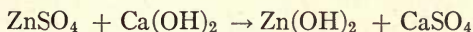

Since both these compounds are paint pigments of a relatively inert character, it is held that any ordinary paint may be applied to a cement surface thus treated. More generally, however, special paints are used, of which there are many commercial forms. A classification of these paints has been proposed by the United States Bureau of Standards² as follows:

1. Linseed oil paints and varnishes.
2. Bitumens.
3. Liquid hydrocarbons.
4. Soaps.
5. Cements.
6. Miscellaneous.

As above stated serious objections apply to paints and varnishes containing linseed oil. Enamel paints (containing

¹ G. B. Heckel in "A Paint Catechism," 2d edition, p. 42.

² Technologic Paper No. 3, by R. J. Wig and P. H. Bates (1912).

hard resins) are more permanent, but are brittle and inelastic. Bituminous paints are very commonly used consisting of solutions of asphaltum, coal tar pitch and wood tar pitch. They are characterized generally by great inelasticity and often fail to stand the weather. The liquid hydrocarbons are usually solutions of paraffin or emulsions of petroleum and fatty oils in ammonia water. When applied to dry walls these coatings form a good continuous film which is, however, entirely superficial and will not resist any considerable head of water. The use of soaps applied as solutions is based upon the formation of lime stearate which is deposited in the voids of the cement surface. The Sylvester process employs alternately solutions of alum and soap, depositing gelatinous aluminum hydroxide in addition to the lime soaps. Cements themselves containing some water repelling substance, such as lime soap, have been used as coatings. Glue and casein are also used in cement coatings, but have not proved entirely satisfactory. Soluble silicates, such as sodium silicate, have been employed as a coating, the silicate combining in part with the lime to form a mono calcium silicate and in part gelatinizing as silica in the surface voids.

From the standpoint of decoration by painting a cement surface with an ordinary paint, it is obvious from the above discussion that a suitable sizing or undercoat must first be applied, after which any paint may be used.

WATER PAINTS

The best example of the so-called cold water paints is *white-wash*. This is obtained by the action of water on lime, forming solid calcium hydroxide, $\text{Ca}(\text{OH})_2$, then adding water until a paste of proper consistency is obtained. A better product is obtained by adding some salt, flour paste, and glue. The lime combines with the protein matter of the flour and forms a cement, thus causing better adherence of the white-

wash. The pigments used in white-wash must be of such a character as to remain unattacked by lime. Yellow or cream is obtained by adding yellow ocher, red by Venetian red, and browns by umber and sienna. By using lampblack and mixtures of the above, tints may be obtained.

Kalsomine is made of carbonate of lime or chalk ground to a fine powder, known as whiting, and a thin solution of glue to act as a binder. Starch and flour are frequent constituents. In order that cold water may be used in mixing, some caustic material, such as lime or soda is added, whereby the resulting heat of solution makes the use of hot water unnecessary.

Casein is obtained from milk. After the removal of the butter fats by centrifugal separators or skimming, the milk still contains casein to the extent of 2.5 to 3 per cent. The latter may be precipitated by (1) acids or (2) ferments. Pure casein may be prepared by precipitating 1000 parts of cold skimmed milk with 2.9 parts of acetic acid. The filtered casein is redissolved in an ammonium carbonate solution, again filtered, and reprecipitated by neutralizing the alkaline solution with acetic acid. Casein is put on the market as a white powder which is soluble in an aqueous solution of any alkali.

A type of casein paint contains the following constituents:

| | | |
|---------------------------|-----|-----------------|
| Casein. | 144 | parts by weight |
| Lime. | 7 | “ “ “ |
| Whiting. | 280 | “ “ “ |
| Iron ore pigment. | 0.2 | “ “ “ |
| Water. | 160 | “ “ “ |

Casein combines with lime to form a glue-like substance which when dry offers fair resistance to fire and is not washed off by water. It is, however, porous and permits water to penetrate. In damp places it is liable to mould and decompose, giving rise to offensive odors.

FIRE RESISTING PAINTS

Oil paints and varnishes are of course highly combustible. The dried film is, however, less easily set on fire. When boric acid (H_3BO_3) is added to oil paints and heat is applied to a film containing boric acid, the latter fuses to a glass which protects the wood from access of air.

A fire resisting paint, which is largely used for desks and wooden surfaces in the proximity of flames is made by precipitating solid aniline black on the wood. For this purpose the wood is first painted with aniline hydrochloride, next with copper sulphate, the excess copper salt is washed off with water, and the wooden surface treated with a solution of paraffin in kerosene.

REFERENCES

I

- ALLEN: Commercial Organic Analysis.
ANDES: Drying Oils.
ANDES: Iron Corrosion, Anti Fouling and Anti Corrosive Paints.
BERSCH: The Manufacture of Lakes and Mineral Pigments.
BOTTLER: German Varnish Making (Translated and Edited by Sabin).
CHURCH: Chemistry of Paints and Painting.
CUSHMAN: The Corrosion and Preservation of Iron and Steel.
ENNIS: Linseed Oil and Other Seed Oils.
GARDINER: Technology of Paint.
GARDINER AND SCHAEFFER: The Analysis of Paints and Painting Materials.
HALL: Chemistry of Paints and Paint Vehicles.
HAWLEY: Wood Turpentine, For. Serv. Bull. 105, U. S. Dept. of Agriculture.
HOLLEY AND LADD: Analysis of Mixed Paints, Color Pigments and Varnishes.
HURST: The Painter's Laboratory Guide.
JONES: The Testing of Raw Materials Used in Paint and Color.
LEWKOWITSCH: Chemical Technology and Analysis of the Oils, Fats and Waxes.

- LIVACHE AND MCINTOSH: The Manufacture of Varnishes and Kindred Industries.
- PARRY AND COSTE: The Chemistry of Pigments.
- SABIN: The Industrial and Artistic Technology of Paint and Varnish.
- SCHWEIZER: Distillation of Resins.
- SCOTT: White Paints and Painting Material.
- SHERER: Casein, its Preparation and Technical Utilization.
- SHERMAN: Methods of Organic Analysis, Revised Edition.
- TOCH: Material for Permanent Painting.
- TOCH: Technology of Mixed Paints.
- Mineral Resources of United States for 1911. (Contains a 5 page bibliography of paints.)
- WOOD: Rustless Coatings; Corrosion and Electrolysis of Iron and Steel.

II

- BALLANTYNE: Oxidized Oils. *J. Soc. Chem. Ind.*, 10, 29 (1891).
- DUNLAP AND SHENK: Oxidization of Linseed Oil. *J. Am. Chem. Soc.*, 25, 826 (1903).
- SHERMAN AND FALK: Influence of Atmospheric Oxidation upon the Composition and Analytic Constants of Fatty Oils. *J. Am. Chem. Soc.*, 25, 711 (1903).
- MCCANDLERS: Examination of Turpentine. *J. Am. Chem. Soc.*, 26, 981 (1904).
- GENTHE: Drying Process of Linseed Oil. *Z. angew. Chem.* 19, 2087 (1906).
- CHEESMAN: Priming Coats for Metal Surfaces. *Proc. Am. Soc. Test. Mat.*, 7, 479 (1907).
- PERRY: Physical Properties of Paint Films. *Proc. Am. Soc. Test. Mat.*, 7, 511 (1907).
- Reports and Discussions on Preservative Coatings for Iron and Steel, *Proc. Am. Soc. Test. Mat.*, 4, 137; 5, 79; 6, 47; 7, 140 (1904-1907).
- BAEKELAND: The Synthesis, Constitution and Uses of Bakelite. *J. Ind. Eng. Chem.*, 1, 149 (1909).
- Report on Preservative Coatings for Structural Materials. *Proc. Am. Soc. Testing Materials*, 9, 139 (1909).
- STAUDT: The Carter Process of White Lead Manufacture. *J. Ind. Eng. Chem.*, 1, 758 (1909).
- TOLMAN: A Study of the Fatty Acids of Fish Oils. *J. Ind. Eng. Chem.*, 1, 340 (1909).
- WALKER AND LEWIS: Paint and Varnish as Accelerators in Corrosion of Metals. *J. Ind. Eng. Chem.*, 1, 754 (1909).

- WHITE: Paints for Concrete, their Need and Requirements. *Proc. Am. Soc. Testing Materials*, **9**, 520 (1909).
- BAEKELAND: Bakelite and its Uses. *J. Frank. Inst.* (1910).
- BURGESS: Experimental Observation on Iron Corrosion. *Proc. Eng. Soc. of Wisconsin*, 188 (1910).
- GARDINER: The Effect of Crystalline Pigments on the Protection of Wood. *J. Frank. Inst.*, August (1910).
- HARKER AND McNAMARA: Electrolysis as a Means of Preventing Corrosion of Iron and Steel. *J. Soc. Chem. Ind.*, **29**, 1286 (1910).
- KREIKENBAUM: Constants of Chinese Wood Oils. *J. Ind. Eng. Chem.*, **2**, 205 (1910).
- SINGH: Analytical Constants of Shellac. *J. Soc. Chem. Ind.*, **29**, 1435 (1910).
- THOMPSON: Scientific Preparation and Application of Paints. *J. Ind. Eng. Chem.*, **2**, 87 (1910).
- VAUBEL: Analysis of Shellac. *Chem. Ztg.*, **34**, 991 (1910).
- BOTTLER: Hardened Resins. *Chem. Abs.*, **5**, 1198 (1911).
- COSTE AND NASH: Turpentine Substitutes. *Analyst*, **36**, 207 (1911).
- GARDINER, SABIN AND McNICHOL: The Prevention of Corrosion of Iron. *Eng. News*, **65**, 636 (1911).
- HOWE: Corrosion of Wrought Iron and Steel, and Improvement of Steel. *Eng. News*, **65**, 637 (1911).
- TOCH: Fish Oil as a Paint Vehicle. *J. Ind. Eng. Chem.*, **3**, 627 (1911).
- WILHELMI: New Oils and Materials for Varnish. *Chem. Ztg.*, **35**, 28 (1911).
- WILLIAMS: Ship-Bottoms Paint. *Proc. U. S. Naval Inst.*, **37**, June (1911).
- VAUBEL: Analysis of Shellac. *Chem. Abs.*, **5**, 1196 (1911).
- VEITCH AND DONK: Wood Turpentine; its Production, Refining, Properties and Uses. U. S. Dept. Agriculture, Bur. Chem., Bull. 144 (1911).
- The Kauri Gum Industry of New Zealand. *Chem. Trade J.*, **49**, 487 (1911).
- The Covering Power of Paint Films. *Oil and Colour Trades J.*, **41**, 710 (1912).
- BANCROFT: The Permanency of Paintings. (Light absorption of pigments.) *Proc. 8th Inter. Congress Appl. Chem.* **20**, 59 (1912).
- CABOT: Carbon Black and Lamp Black. *Proc. 8th Inter. Congress Appl. Chem.* **12**, 13 (1912).
- CLEMENT AND WALKER: Electrolytic Method for the Preventing of the Corrosion of Iron and Steel. *Proc. 8th Inter. Congress Appl. Chem.* **26**, 491 (1912).

- FLEMING: Corrosion of Iron in Pure Water and Air Combined. *J. Ind. Eng. Chem.*, 4, 480 (1912).
- HAWLEY: Wood Turpentine, their Analysis, Refining, Composition, and Properties. *Proc. 8th Inter. Congr. Appl. Chem.*, 12, 41 (1912).
- HERTY: The Naval Stores Industry. *Proc. 8th Inter. Congr. Appl. Chem.*, 12, 101 (1912).
- LUSSKIN: Herring Oil. *Proc. 8th Inter. Congress Appl. Chem.* 12, 155 (1912).
- OLSEN AND RATNER: The Decomposition of Linseed Oil During Drying. *Proc. 8th Inter. Congress Appl. Chem.* 12, 165 (1912).
- Painting Exposed Structural Steel. *Eng. Rec.*, 66, 458 (1912).
- RIDDLE: Protective Coatings. *Proc. Eng. Soc. of Western Penn.*, 28, 1 (1912).
- STOREY: Sherardizing Process. *Wisconsin Engineer*, 16, 300 (1912).
- TOCH: Soy Bean Oil as a Substitute for Linseed Oil in Paints. *J. Soc. Chem. Ind.*, 31, 572 (1912).
- WILLIAMS: Modern Painting Methods of the U. S. Navy. *Proc. 8th Inter. Congr. Appl. Chem.*, 12, 203 (1912).
- SCHAEFFER: The Manufacture and Properties of Sublimed White Lead. *J. Ind. Eng. Chem.*, 5, 144 (1913).
- TOCH: Paint as an Engineering Material. *J. Ind. Eng. Chem.*, 5, 366 (1913).

CHAPTER XV

PLASTICS FOR ELECTRICAL INSULATION

ELECTRICAL insulating materials owe their importance at the present time largely to the enormous development of applied electricity. While in general, all insulators must be alike, in that they are non-conductors of electricity, yet in other respects, they may vary in properties according to the uses to which they may be put; whether used in high voltage transmission lines or in the winding of armatures, or for fixed positions as in house wiring, in conduits and on poles.

According to R. A. Fessenden,¹ an insulator performs its function first by reason of being able to withstand the mechanical stress of the voltages with which it is used, and second by reason of being so poor a conductor that a negligibly small current can flow through it. The first property is known as its dielectric strength and is measured by comparison with air as the unit, and the second is called its resistance.

In addition to having a high dielectric value and high resistance, a good insulator for most purposes must be² sufficiently tough to withstand strains and vibrations, must be flexible and durable, must exclude moisture, and must not easily be affected by changes of temperature or by acids.

The various classes of insulating materials include natural products like mica and talc, clay products, glass, rubber, and various artificial products, such as fiber, vulcanized fiber, insulating paints, cloths, etc. In order to consider these materials in a somewhat systematic manner the following classification will be used:³

¹ *Proc. Am. Inst. Elec. Eng.*, **15**, 119 (1908).

² Turner and Hobart: *Insulation of Electric Machines*, p. 4.

³ Prepared by A. S. Watts, Ceramic Engineer for Locke Insulator Manufacturing Company, Victor, N. Y.

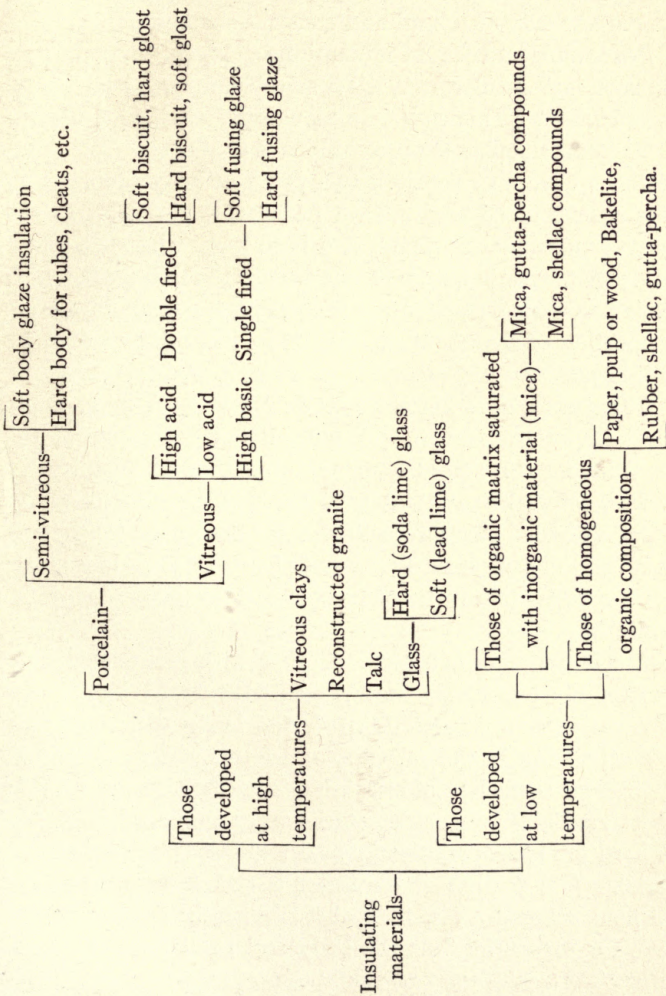

HIGH TEMPERATURE INSULATORS

Insulating materials of this type have a composition which enables them to withstand a high temperature without fusing and are usually of a hard and compact structure.

Porcelain and its Modifications.—In the manufacture of porcelain insulators a clay suitable for porcelain ware (see Chapter XI) is used. In moulding and shaping the various forms the plastic process alone is employed. The semi-vitreous ware may consist either of a soft body prepared by pug mills and covered with a feldspathic glaze, or, in the case of tubes and conduits, of a hard body without a glaze. Vitreous porcelain may be made from acid mixtures in which silica predominates, or from basic products containing a large proportion of lime or magnesia, or from a mixture of these two bases.

The surface covering of porcelain insulators is perhaps the most important feature. A more detailed account of the artificial mixtures used for glazes described in Chapter XI will therefore be given at this point. This class of glazes may be divided into three sub-classes¹ known as: (1) the soft fire, or majolica glaze; (2) the hard fire, or porcelain glaze; (3) a combination of the soft and hard fire glazes known as white ware glaze.

A soft fire glaze is a soft lead glass with just enough clay to keep it from setting until placed on ware. When a ware covered with this glaze is fired, the lead melts, combines with the silica in the mixture, and forms a glass which has a different coefficient of expansion from the clay ware and is therefore liable to produce cracks when subjected to strain. A hard fire glaze contains no lead and but little fluxing material. Just enough of the latter is added to cause fusion without running. The flux must require the same temperature for "maturing" as the body and must have the same

¹ Engineering Sheet No. 4, by Locke Insulator Mfg. Co., Victor, N. Y.

coefficient of expansion. White ware glaze is used on biscuit ware. As previously explained (Chapter XI), biscuit ware requires double firing: first, for the purpose of giving the desired density to the body; and second, in order to glaze it uniformly and smoothly. In the manufacture of porcelain insulators the single fired products are usually preferred. In these the glaze is placed upon the body in the green state, which permits it to penetrate and form a firm bond before firing and thus obtain a greater uniformity of expansion between the body and its glaze.

Vitreous clays may be moulded by both the plastic and the dry processes. They vitreify at about 1250° C. but remain porous at 1200° C. They contain generally from 20 to 30 per cent alumina and a higher proportion of fluxes than the refractory clays.

Reconstructed granite or other natural silicates, such as feldspar and porphyry, when heated to a temperature near that of their fusing point, like kaolin, undergo a change in structure (chiefly reduction of the volume and increase of the density of the body). This property enables such silicates to be used in the manufacture of insulators. The material is first reduced to the finest powder and then moulded by means of the dry press.

Talc has recently come into extensive use in electrical insulation. It is prepared in two forms which go by the name of "Lava" and "Lava composition." The former is in reality the natural compound talc ($H_2Mg_3Si_4O_{12}$). This, on account of its softness may be machined in its natural condition. It is next heated to 1100° C. and assumes such hardness that it cannot be cut except by the diamond. "Lava composition" is a mixture of talc, in the form of an impalpable powder, with a suitable binding material. This mixture is then placed in hydraulic presses which deliver it in forms as desired. The material is next dried in air and heated in gas fired kilns until all moisture is removed. The semi-hardened material is

then sawed, turned, milled, drilled and variously machined, and finally hardened by heating up to 1100° C., as in the case of talc. On account of its heat resisting power, its strength and ease of machining, together with its good insulating properties, it is of considerable importance.

Glass.—The use of glass insulators is almost entirely limited to low voltages as, for example, in telephone and telegraph lines. When used it consists generally of hard glass pressed in the viscous state into the shapes and forms desired and carefully annealed for a long time to give a uniform temper. The objection to glass as a material for insulators is its tendency to burst and break from unknown causes, a defect which apparently cannot be overcome by glass makers. Soft glass when exposed to the elements is acted on in a short time, so that a rough surface is formed and a decided leakage eventually developed.

LOW TEMPERATURE INSULATORS

Before discussing the composition of insulators made at low temperature, it is desirable to consider briefly the production of rubber and allied products, since they enter so largely into the manufacture of the various compounds.

Caoutchouc or India Rubber.—Certain plants found growing in tropical regions between the 30th parallel north and the 30th parallel south latitude, are capable of producing caoutchouc. When such a plant is cut, a sap of milky character exudes, which is known as the latex. If the latex is heated at a low temperature, the minute globules separate from the watery part in the form of a firm substance known as caoutchouc, the name given it by the South American Indians. The composition of this latex according to Clouth ¹ is

| | |
|--------------------------|-------------|
| Pure caoutchouc. | 32 per cent |
| Albumen and ash. | 12 “ |
| Water. | 50 “ |

¹ Rubber, Gutta Percha and Balata, p. 10.

The name "India rubber" came into use in England after 1775, following the suggestion of Priestly in 1770 that caoutchouc might be used for "rubbing out" pencil marks, and the small cubes sold in the stationer's shops were therefore called "India rubber."

When the latex is coagulated by the application of heat at a low temperature, it still contains many impurities, such as sand, fibers, sugars, etc., which are removed by washing with water. The drying of the washed rubber is done *in vacuo* to prevent oxidation. This product, while known technically as pure rubber, contains certain oily and resinous matters which may be removed by such solvents as alcohol and acetone.

Chemically pure rubber is a colorless substance with a specific gravity of 0.911 at 117° C., while the commercial varieties are usually somewhat heavier and run from 0.915 to 0.931. It is insoluble in water, but when immersed for some time it is capable of absorbing about 25 per cent of its own weight. It is soluble in turpentine, dipentene, petroleum ether, and carbon disulphide. Benzol (benzene) and petroleum ether are the commercial solvents, 160° benzol or solvent naphtha being usually employed. Certain gases have the power of diffusing through rubber, the relative rate of diffusion being given by Graham as follows: ¹

| | |
|--------------------------|--------|
| Nitrogen. | 1.000 |
| Carbon monoxide. | 1.113 |
| Air. | 1.149 |
| Methane. | 2.148 |
| Oxygen. | 2.556 |
| Hydrogen. | 5.500 |
| Carbon dioxide. | 13.585 |

When heated, rubber softens to a pasty consistency and finally becomes fairly liquid at 170° C. to 180° C.

Rubber is a typical colloid, it does not exhibit abrupt

¹ *Phil. Trans.*, 1866, p. 399.

physical changes, such as definite melting points, boiling points, solution, etc. These changes in the case of a colloid are continuous. For example, the so-called solutions are no more solutions of rubber in the solvent than solutions of the solvent in rubber. Thus, when benzene is added to rubber, the former passes into the latter, swelling it, permeating every part, and forming a jelly. On adding more benzene the jelly begins to flow.

The chemical composition of rubber shows it to be a hydrocarbon having the formula $C_{10}H_{16}$, and the investigations of Wallach¹ define it as a compound of the terpene type. When India rubber is treated with a halogen, like bromine, both addition and substitution products, $C_{10}H_{16}Br_4$ and $C_{10}H_{15}Br_5$, are formed. The action of the halogen acids is somewhat similar, $C_{10}H_{16}HCl$ being formed.

VULCANIZED RUBBER

The addition of sulphur to rubber produces a marked change in the properties of rubber. This process is known as vulcanization. To the chemical action of sulphur and sulphur monochloride may be attributed the commercial importance of the India rubber industry. In 1839 Nelson Goodyear showed that when India rubber is treated at high temperatures with sulphur, the elastic properties of rubber are maintained in a constant manner within a wide range of temperatures. The process of vulcanization consists merely of heating sulphur and India rubber at temperatures between 125° F. and 360° F. It is known that the rubber absorbs about 3 per cent of its weight of sulphur. To facilitate this reaction, sulphur carriers, such as lead sulphide, zinc sulphide, etc., are generally added. The same result may be obtained by treating a solution of rubber in carbon disulphide with sulphur monochloride, S_2Cl_2 , which is known as the "cold" process (or Parks process).

¹ *Ann.*, 227, 292.

The color of vulcanized rubber is light gray. Its porosity is much less than that of the natural rubber. Its self-adhesive power has disappeared and its elasticity is greater than in the case of raw rubber. Like the raw product, it is a poor conductor of heat and electricity. While natural rubber becomes brittle at low temperatures, the vulcanized rubber is not affected, and up to 120° F. heat causes no deterioration. It resists the action of alkalies and acids, but is damaged by the action of light and air when in a moist condition, losing both its strength and elasticity.

HARD RUBBER (EBONITE)

Hard rubber is a form of vulcanized rubber carrying often from 40 to 50 per cent of sulphur together with various fillers, such as chalk, resins, sulphides, etc. It is vulcanized in the same manner as soft rubber, but some of its properties are quite different. It is black in color, and a nonconductor of electricity. It is unaffected by water, light, and atmosphere, and is acid proof. It can be worked in a lathe, sawed, planed, and polished.

RECLAIMED RUBBER, RUBBER SUBSTITUTES, AND RELATED SUBSTANCES

The large number of uses to which rubber has been put in the arts and industries has stimulated the reclaiming of rubber from used rubber goods¹ and also the search for rubber substitutes. Two of these are of sufficient importance to be considered, viz., *vulcanized linseed or corn oil*, and *artificial rubber*. The former consists of compounds formed by the action of sulphur or sulphur chloride on the linolein of the oil in a way that is perhaps comparable to the action of oxygen to produce linoxyn (q. v.). Vulcanized oil is used

¹The Utilization of Waste India Rubber. *Sci. Am. Sup.*, 63, 26322 (1907).

for waterproofing cloth and as an adulterant of natural rubber.

The production of *artificial rubber* has not yet proved commercially feasible, although the process from a scientific standpoint may be made to yield a product which is similar in properties to caoutchouc obtained from the rubber plants. The process used is based upon reactions which require fuller explanation than can be given in a brief discussion. The reader is accordingly referred to the literature which is descriptive of these reactions (see lecture of Professor Tilden in *India Rubber Journal*, October 5, 1908; lecture by Professor Harries in *Gummi Zeitung*, March 18, 1910; and editorial in *Journal of Industrial and Engineering Chemistry*, 3, 279 (May, 1911) and lectures by Professor Perkins and by Dr. Druisberg in the *Transactions of the Eighth International Congress of Applied Chemistry*).

Gutta-Percha.—This material is often considered identical with caoutchouc or India rubber, but it is obtained from different plants and in a somewhat restricted area in the East Indies. Its properties also differ markedly from those of caoutchouc. It has a cellular structure, becoming fibrous when stretched, and has an elasticity similar to that of soft leather.

The specific gravity varies from .980 to .999. When heated to 99° F. it becomes soft, at 195° it can be moulded, and it retains the shape given to it at ordinary temperatures. It melts at 265° and may be distilled, yielding a colorless oil. Low temperatures do not affect gutta-percha, but, like caoutchouc, when exposed to light, moisture and air, it suffers oxidation. It is a nonconductor of heat and electricity. Clouth states its resistance to electricity at 75° F. to be 6×10^{19} with copper taken as unity. It is soluble in carbon bisulphide, chloroform, petroleum ether, and partly soluble in turpentine and olive oil. It is alkali proof and is unaffected by concentrated hydrochloric acid. Oxidizing agents, how-

ever, attack it strongly. Since it does not form a compound of any industrial value with sulphur, no vulcanized product is manufactured. It is prepared by a process of washing, kneading, and pressing, similar to that of rubber. Its uses are very extensive, that of an insulating material for submarine and underground cables being perhaps its most important application.

Balata.—This product has been largely confused with gutta-percha but differs in being produced from a different genus of the same family of plants from which gutta-percha is obtained. That which chiefly distinguishes it from gutta-percha, however, is its resistance to oxidization in the air. In other respects it is quite similar to gutta-percha and is manufactured into industrial articles in the same manner. It is largely used for driving belts, and when mixed with gutta-percha and other materials constitutes a good insulating material.

Guayule and **African rubber** should also be mentioned as commercially important additions to the rubber supply.

MIXTURES AND COMPOSITIONS

Numerous artificial mixtures and compositions are on the market for use as electrical insulating material. As noted in the classification, these materials are developed at temperatures which are low compared with the inorganic insulating materials. In the case of compounds containing organic binders, the temperature is merely high enough to give maximum plasticity for moulding and shaping the forms, which after pressing and cooling are ready for use.

Mica.—Mica compounds and compositions have long been used for insulating on account of the insulating qualities of the mineral mica, which is an anhydrous silicate of aluminum and potassium or sodium ($\text{KH}_2\text{Al}_3\text{Si}_3\text{O}_{12}$). The mineral itself, when obtainable in proper sizes, is largely used. Its

lack of flexibility and uniformity and its tendency to permit surface leakage, together with the high cost of the mineral due to the large proportion of waste, have brought about the manufacture of reconstructed mica. In the preparation of mica compounds, thin sheets of mica are assembled, coated with shellac or some other insulating cement, and under heat and high pressure formed into the shapes desired. Various degrees of flexibility may be obtained by heating such compounds.

Impregnated Wood Pulp.—Fibrous insulating materials are made from wood pulp prepared similarly as in the manufacture of paper (Chapter XVI). In a moist condition the pulp is deposited upon forms, under pressure, in thin films, and in successive layers, until the desired thickness is obtained. This tends to unite the individual fibers and form a solid body of homogeneous structure. It is next air dried, after which it is placed in a vat of bituminous liquid. This liquid is allowed to permeate the entire structure, which after absorption has the appearance of hard rubber, when the ends are cut in a lathe. Fiber conduits thus made are extensively used and are claimed to be water, acid, and alkali proof, good insulators, and not subject to expansion and contraction.

Vulcanized Fiber is the name given to a chemically treated pulp. When a saturated solution of zinc chloride is added to pulp the fiber becomes gelatinous. It is next pressed, washed, kneaded, rolled, and cured by various methods. Two classes of fiber, hard and flexible, are made. The former has the consistency of horn with a tensile strength of about 10,000 pounds per square inch and with a high degree of toughness. When used under dry conditions it is a good insulator. A thickness of $\frac{1}{8}$ " to $\frac{1}{2}$ " has a "break down" strength of over 10,000 volts. When aged and thoroughly seasoned, its resistance is increased. It is insoluble in alcohol, ether, turpentine, and mineral oils. It will absorb

water, swelling when wet, and resuming its original size when dry. Flexible vulcanized fiber has the consistency of a close grained sole leather, its flexible nature being due to the addition of certain deliquescent substances, such as glycerol or glucose, to treated pulp. The other properties of flexible vulcanized fiber are similar to those of the hard fiber. When subjected to a further process of nitration, vulcanized fiber is said to become waterproof. The efficiency of this fiber is dependent upon the complete removal of the zinc in the washing process. If zinc remains it destroys the toughness and causes the fiber to become brittle.

BAKELITE

Among the materials largely used for the insulation of electric coils in dynamos and motors is Bakelite, a chemical compound which has been patented by its inventor, Dr. Leo H. Baekeland. Its composition and properties have been described under the head of paint materials in Chapter XIV. Like resins, particularly shellac, Bakelite has a high dielectric value, and has the advantage, in addition to its infusibility, of being a better conductor of heat than the resinous bodies. Bakelite is used in the preparation of mixtures along with substances like asbestos, wood flour, blotting papers, etc. The dielectric value of Bakelite is shown in the following table:¹

TABLE 40.—Dielectric Values of Bakelite Preparations

| <i>Test sample</i> | <i>Thickness in mm.</i> | <i>Volts per millimeter at puncture</i> |
|---|-----------------------------|---|
| "C" Bakelite. | 2.18 | 14,200 |
| Moulded composition, 70 asbestos, 30 Bakelite | 8.00 | 8,500 |
| Moulded composition, wood flour and Bakelite. | 7.90 | 11,000 |
| Impregnated blotting paper. | 3.66 | 27,880 |
| Impregnated pressed paper. | 1.60 | 33,500 |

¹ *J. Ind. Eng. Chem.*, 3, 937 (1911).

GUTTA-PERCHA SUBSTITUTES

In addition to the substances above described a large number of so-called gutta-percha substitutes are used, such as *ozokerite*, *nigrite*, *shellac*, and *Chatterton's compound*. *Ozokerite* is a natural wax found in the vicinity of some petroleum wells. It possesses good dielectric properties and is unaffected by atmospheric agents. *Nigrite* is a mixture of India rubber and the residue from the distillation of *ozokerite*. It has a high insulation power and a low induction capacity. *Shellac* has been previously described in the chapter on paint and varnish materials. It is generally incorporated with other substances such as paper, cloth, asbestos, etc., and has a high insulating value. *Chatterton's compound* is a mixture of gutta-percha, rosin, and wood tar.

REFERENCES

I

- CLOUTH: Rubber, Gutta-Percha, Balata.
DITMAR: The Synthesis of Rubber.
HEIL AND ESCH: The Manufacture of Rubber Goods.
MARTIN: Industrial and Manufacturing Chemistry, Organic.
PEARSON: Crude Rubber and Compounding Ingredients.
SCHIDROWITZ: Rubber.
SEELIGMANN: India Rubber and Gutta-Percha.
TERRY: India Rubber and its Manufacture.
WEBB: A Practical Guide to the Testing of Insulating Wires and Cables.
WEBER: Chemistry of India Rubber.

II

- FESSENDEN: Insulation and Conduction. *Proc. Am. Inst. Elec. Eng.*, **15**, 119 (1898).
WATTS: Porcelain for Electrical Purposes. *Trans. Am. Ceram. Soc.*, **4**, 86 (1902).
SEMENZA: Lines and Insulators. *Trans. Am. Inst. Elec. Eng.*, **23**, 147 (1904).

- The Mechanical Examination and Analysis of Manufactured Rubber. *Eng. News*, **56**, 551 (1906).
- WATTS: Porcelain for Electrical Purposes. *Trans. Am. Ceram. Soc.*, **6**, 600 (1907).
- BAEKELAND: The Synthesis, Constitution and Uses of Bakelite. *J. Ind. Eng. Chem.*, **1**, 149 (1909).
- SHARPLES: Utilization of Waste India Rubber. *Trans. Am. Inst. Chem. Eng.*, **2**, 229 (1909).
- BUIZOV: Theory of Cold Vulcanization. *Z. Chem. Ind. Kolloide*, **6**, 281 (1910); *Chem. Abs.*, **5**, 3170 (1911).
- BOGGS: Chemical Specifications for Rubber Covered Wires and Cables. *Elect. World*, **56**, 1234 (1910).
- SEIDEL: Action of Litharge During the Hot Vulcanization of Rubber. *Gumm. Ztg.*, **24**, 710, 748 (1910); *Chem. Abs.*, **5**, 2188 (1911).
- VAN DER LINDE: Guayule Rubber. *J. Soc. Chem. Ind.*, **29**, 1283 (1910).
New Specifications of National Fire Protection Association for Rubber Covered Electric Wires. *Eng. News*, **65**, 522 (1911).
- HINRICHSSEN: Scientific and Economic Problems in the Rubber Industry. *Chem. Ztg.*, **35**, 1308 (1911).
- JONES: Analysis of Rubber Compounds. *Elect. World*, **59**, 320 (1912).
- FRANK: Preparation of Raw Caoutchouc. *Chem. Ind.*, **35**, 339 (1912).
- FRANKENBURG: History of the Commerical Development of India Rubber. *J. Soc. Chem. Ind.*, **31**, 416 (1912).
- HARRIES AND HOFMANN: Synthetic Rubber. *Chem. Zeit.*, **36**, 654 (1912).
- HINRICHSSEN: Chemistry of Rubber. *Gumm. Ztg.*, **26**, 1408 (1912).
- HINRICHSSEN: Where Rubber Comes from. *India Rubber J.*, **43**, 1208 (1912).
- KORBER AND DILTSCH: Ceramic Materials of High Electrical Resistance. *Céramique*, **14**, 203; *Chem. Abs.*, **6**, 2679 (1912).
- U. S. Bureau of Standards, Circular 36: The Testing and Properties of Electric Condensers (1912).
- U. S. Bureau of Standards, Circular 38: The Testing of Mechanical Rubber Goods (1912).
- GOLDBERG: The Determination of Rubber in India Rubber Goods with Special Reference to the Specifications of the Association of German Electro-technologists for Insulated Wire. *Chem. Ztg.*, **37**, 85; *Chem. Abs.*, **7**, 1424 (1913).

CHAPTER XVI

CELLULOSE PRODUCTS

CELLULOSE as a raw material is of large industrial importance. Its use in the preparation of plastics has already been considered and its employment as a raw material in the manufacture of explosives will be described in the next chapter. From an industrial point of view other products of interest are paper, textiles, artificial filaments, pyroxylin compositions, viscose preparations, and the more recent use of sawdust in the manufacture of ethyl alcohol.

Cellulose occurs as a product of vegetable life and constitutes what is known as the framework of the vegetable cell. Filter paper, cotton, and linen are among the best examples that may be cited as a near approach to pure cellulose. From a chemical standpoint it is classed as a carbohydrate. Its ultimate composition is represented by the formula, $C_6H_{10}O_5$, but its constitution although not yet established, is believed to be very much more complex than the simple formula above given. The formula, therefore, is generally written as $n(C_6H_{10}O_5)$ or as $(C_6H_{10}O_5)_x$. It is related to the sugars, inasmuch as a simple hydrolysis, $C_6H_{10}O_5 + H_2O \rightarrow C_6H_{12}O_6$, will yield fermentable sugar.¹

Cellulose as a physical aggregate is regarded as being colloidal in its nature. This property is, of course, manifested in the so-called solutions only, which are not solutions in the same sense that sodium chloride in water, for instance, is a solution. Unlike the latter, typical colloids dissolve to vis-

¹ The experiments of Ost and Wilkening, *Chem. Ztg.*, **34**, 461, show that cellulose may be converted into fermentable sugars to the extent of 90 per cent.

cous or gelatinous masses, which are nonconductors of electricity, exert no osmotic pressure, have no thermal effect, and produce a very slight volume change in dissolving.

Cellulose is insoluble in the ordinary neutral solvents, but is dissolved by some metallic salts, such as a concentrated (40 per cent) solution of zinc chloride at 80° C., or by a solution of cupric hydroxide in cold ammonium hydroxide. It is thought that the so-called solution is, however, a colloidal double salt of cellulose with the metallic salt. By preparing cellulose esters, such as the acetate for example, the use of such solvents as chloroform, ether-alcohol, acetone, pyridine, and phenol may be used to effect solution. The preparation of the acetate, may be represented by the equation:

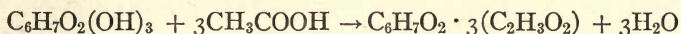

When the resulting cellulose acetate is treated with hot alkaline solutions (equal volumes of normal sodium hydroxide and alcohol), the acetyl group may be removed and cellulose regenerated.

In addition to cellulose as above described, other cellulose-like substances usually occur in association with cellulose. Chief among these substances are oxycellulose, lignocellulose and hydrocellulose.

Oxycellulose is obtained from straw, esparto, and bamboo, or by the action of oxidizing acids on cellulose. The investigations of Cross and Beven and the more recent work of Berl and Klays¹ has shown that the oxycelluloses contain a larger proportion of oxygen and differ markedly from normal cellulose in their chemical reactions. They are readily soluble in hot alkalis, contain aldehydic groups, are easily attacked by hydrolyzing agents and are decomposed by hot hydrochloric acid, giving a relatively large yield of furfural.

Lignocellulose occurs in raw jute and wood fibers, constituting the so-called "lignin," which binds the cellular

¹ *Moniteur Scientifique*, 24, 103 (1910).

matter of the wood together. According to Cross and Bevan, the lignocelluloses are compounds of cellulose with bodies which have the characteristics of diketones and are often called lignones. When treated with chlorine, the lignone forms a chlorine addition product soluble in neutral solvents, such as alcohol, etc. Industrially the action of bisulphites is of more importance. Cross and Bevan¹ show that when lignocellulose is treated with the bisulphites of the alkali or alkaline earth metals at elevated temperatures and under pressure, cellulose is obtained as an insoluble residue, and the sulphonated derivatives of the lignone are in solution. Lignocellulose dissolves in zinc chloride and forms esters similar to the normal cellulose. The lignone groups are believed to be unsaturated cyclic compounds and very reactive; whence the necessity for the removal of the lignone compounds in order to produce stable cellulose products for industrial uses.

The action of water upon cellulose when the latter is boiled in it under pressure produces a form of cellulose known as *hydrocellulose*, to which the formula $C_{12}H_{33}O_{11}$, has been assigned. It is usually prepared by the action of acids on cellulose, the resulting hydrocellulose being washed free from acids and dried. It is manufactured on a large scale as a raw material in the production of guncotton (q. v.) for explosive purposes.

THE USE OF CELLULOSE IN THE MANUFACTURE OF PAPER

One of the largest uses of cellulose is in the production of paper pulp. The raw materials used in the manufacture of paper are rags, mechanical wood pulp, and chemical wood pulp. Straw and esparto grass are used for the cheaper grades of paper. Jute is made into strong wrapping paper.

Rags are bought by the paper maker in a roughly assorted condition. They are first sorted as to fiber, i. e., whether

¹ Cross, Bevan, and Sindall: Wood Pulp and Its Uses.

linen, cotton, hemp, or woolen, and finally into colors, namely, white, blue, gray, red, and dark, including black. They are next cut into small pieces, dusted, boiled with alkalis and bleached.

Wood holds a dominant place in paper manufacture on account of its great abundance. The annual production of wood pulp for 1908 is given in the following table taken from Cross, Bevan, and Sindall (*loc. cit.*):

TABLE 41.—Annual Production of Wood Pulp

| | <i>Mechanical pulp</i> (air dry tons) | <i>Chemical pulp</i> (air dry tons) | <i>Total annual production</i> (air dry tons) |
|------------------|--|--|--|
| Germany. | 315,000 | 320,000 | 635,000 |
| Norway. | 421,000 | 270,000 | 691,000 |
| Sweden. | 78,000 | 510,000 | 588,000 |
| Finland. | 69,000 | 52,000 | 121,000 |
| America. | 868,000 | 988,000 | 1,856,000 |
| Canada. | 565,000 | 172,000 | 737,000 |
| | 2,316,000 | 2,312,000 | 4,628,000 |

Mechanical pulp is the name given to ground wood. It consists of wood fibers produced by the disintegration of wood by the action of grindstones revolving against the wood surface. In the cold process, the grinding is done in the presence of a large excess of water which carries away the disintegrated fibers into reservoirs. When the quantity of water is lessened the temperature due to friction rapidly rises and the pulp thus produced is known as "hot ground" pulp. The latter is quite different from "cold ground" pulp, the fibers being longer and the pulp coarser. The temperature at the grinding surface is about 65° C., and is carefully controlled to avoid the burning of the pulp. After screening to remove coarse material, the pulp goes to the wet press machine for

the removal of excess water, and finally to the hydraulic press, where it is pressed into sheets and packed in bales for shipment to the paper mill. For use in the manufacture of "leather board," brown pulp is used. This is mechanical pulp made from wood which has been previously digested in steam or hot water under pressures corresponding to temperatures of 120° to 60° C. This digestion removes organic acids from the sap, as well as volatile oils and resins.

Chemical Wood Pulp.—By the action of certain chemicals on the non-cellulose constituents of wood these are largely dissolved away leaving a residue of impure cellulose which is called chemical wood pulp. The principle underlying this process is the removal of bonding or encrusting agents by rendering them soluble and leaving the cellulose in as nearly pure condition as possible. The isolation of the wood fibers is thus brought about by a chemical process, producing a pulp of a different composition from the raw wood. The extent to which this is accomplished is evident from the following statement: ¹

| | <i>Spruce wood</i> | <i>Chemical pulp from spruce</i> |
|----------------------------|--------------------|----------------------------------|
| Moisture. per cent | 11.5 | 6.7 |
| Ash. " | 0.3 | 0.5 |
| Cellulose. " | 53.0 | 89.7 |
| Lignone matter. " | 35.2 | 3.1 |

Two typical processes are in use: (1) acid and (2) alkaline. The sulphite process is typical of the former and the soda process of the latter.

Sulphite Process.—In the sulphite process a solution of calcium and magnesium bisulphites is prepared by passing

¹ Griffith and Little: Chemistry of Paper Making.

sulphur dioxide into milk of lime and magnesia. The solution also contains an excess of free sulphurous acid. The strength of the liquor is measured by the hydrometer; a 5° Bé solution had in a typical case the following composition:

| | |
|---------------------------------|---------------|
| Total sulphurous acid. | 3.25 per cent |
| Combined sulphurous acid. | 0.87 “ |
| Available sulphurous acid. | 2.38 “ |
| Lime in combination. | 0.76 “ |

Wood in the form of chips is digested with this solution in closed vessels under high pressure for certain periods of time. Many modifications of this method are in use, but in general, the process renders the lignocellulose soluble, leaving the cellulose in a fairly pure state. The analysis of the waste liquor of the sulphite process indicates that its characteristic constituent is the calcium salt of lignone sulphonic acid formed from the interaction of the bisulphites with the ketonic groups of the wood. In endeavoring to utilize this waste liquor, recent attempts have been made to produce alcohol from it by neutralizing with lime, aërating, fermenting by means of yeast, and afterwards distilling. The yield of ethyl alcohol is about 60 liters per ton of cellulose.

Soda Process.—The soda process makes use of a solution of caustic soda, NaOH. The latter is usually made from sodium carbonate, Na₂CO₃, as the raw material, by treatment with lime, according to the reaction:

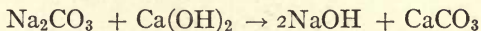

This reaction takes place in tanks equipped with agitators and steam coils for heating. A solution of caustic soda having a density of 15° Bé is usually prepared and is diluted before using to about 11½° Bé. The wood first has its bark removed and then passes through a wood chipper and is reduced to small pieces. It is next conveyed to digesters or cylindrical iron tanks, about 27 feet in length, and 6 feet in diameter,

and the caustic soda solution added, about 900 gallons being used per cord of wood. The digester is then sealed, steam is introduced, and a pressure of 120 pounds (170° C.) is maintained for 10 hours.

The action of sodium hydroxide under such conditions dissolves the lignone compounds, organic acids, and resins, and leaves an insoluble residue of nearly pure cellulose of a brown color. The spent liquor is next conducted to evaporators of the Yaryan type (q. v.) and concentrated to 32° Bé, after which it passes to a rotary furnace for calcination. The product of the rotary furnace is a dark colored ash consisting of about 48 per cent sodium carbonate, known as soda ash, and 52 per cent carbon. This ash is leached with water to dissolve the sodium carbonate, and this is then causticized by lime and again used. This portion of the process is known as "soda recovery."

Bleaching.—After the preparation of chemical pulp by either method above described, it is carefully washed and bleached. For this purpose one of two substances is generally employed: (1) bleaching powder, or (2) solutions of hypochlorite of soda or magnesia, prepared by electrolyzing the chlorides.

Bleaching powder is hypochlorite of lime, CaCl.OCl , and its bleaching action is due to its oxidizing power. Its commercial value is, however, dependent upon what is called the available chlorine. Its properties may be represented by the following reactions:

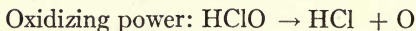
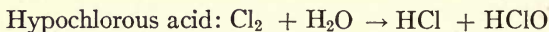
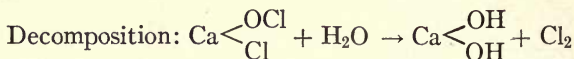

The nascent oxygen in the last equation combines with the colored substances of the pulp forming colorless or bleached compounds.

Electrolytic bleach is prepared by the electrolysis of brine from salt beds. This brine consists of a mixture of sodium and magnesium chlorides. When treated by the Castner¹ process, caustic soda is produced, and the chlorine is led into hydrated lime chambers, forming hypochlorite of lime. This product, although often called electrolytic bleach, is in no sense different from ordinary bleaching powder.

Electrolytic bleaching in a narrower sense consists of the electrolysis of sodium chloride by means of a series of small independent decomposing cells, through which the salt solution is passed continuously until the required amount of "available chlorine" is obtained in the solution. The resulting sodium hypochlorite, NaOCl, is then drawn off and used for the bleaching of the pulp. When the Siemens and Halske apparatus is used, sodium hydroxide and chlorine are produced, and are caused to interact outside of the apparatus to form the desired bleaching liquor. The use of electrolytic bleach seems to be dependent upon cheap electrical power.² It is also claimed to be more efficient than the ordinary bleaching powder.

Preparation of Pulp for Paper Making.—After the pulp is bleached it goes to the drainers where the bleaching liquid is removed and the pulp is carefully washed. It now passes to the "beaters" or beating engine, which is an oval tub, 15 to 20 feet long by $3\frac{1}{2}$ feet deep, divided into two channels by a partition or "mid-feather." On one side of this is a large roll carrying on its circumference a number of knives which are adjusted with reference to similar knives in the "bed-plate" underneath the roll. The pulp passes through the knives and into the channel on the other side, then again is drawn between the knives until the fibers are finally separated

¹ For description of the apparatus used in the electrolysis of brine, consult text-books of general inorganic chemistry.

² For cost data and an excellent description of the various electrolyzers, see Cross, Bevan and Sindall: *Wood Pulp and its Uses*, p. 166.

and broken up into finer particles. While the pulp is being thus disintegrated, the filler, size, and color are added and thoroughly incorporated.

China clay, a silicate of aluminum, and talc, a magnesium silicate, are the principal fillers employed. Their function is to fill up the pores between the fiber and make an opaque and uniform sheet. The fibers have, however, the power of readily absorbing any liquid that comes in contact with them, a property well illustrated by blotting paper. It is therefore necessary to cover them with a varnish-like coat. The materials commonly employed for this purpose are resin, soaps and alum, although glue, starch, and casein are also used. This process is known as sizing.

Resin size is produced by boiling the crude resin with a sodium carbonate solution and adding the resulting soap to the pulp. About 5 per cent of filler and 3 per cent of size based on the weight of the wet pulp are used. After the pulp, filler, and size have been thoroughly mixed in the beating engine, a solution of aluminum sulphate is added to neutralize the sodium of the resin soap, thus forming free resin, aluminum hydroxide, and sodium sulphate. The latter drains off, while the resin and aluminum hydroxide form coatings over the fibers. Coloring matter is also added at this stage for colored paper.

From the beating engine the stock pulp passes to the paper machine which is known as the Fourdrinier. This machine consists of a fine mesh, endless wire cloth upon which the stock forms into a sheet, the water draining through the meshes of the wire, and the fiber forming an interlaced sheet of uniform thickness. This sheet next has its surplus water removed by means of vacuum boxes located under the wire, and by the action of rolls, which also serve to compress the fibers into a firm adherent sheet. The paper is next freed from moisture by passing over the drying rolls, which are cast iron hollow cylinders heated by steam. From the driers

the paper is passed through a number of chilled cast iron rolls with polished surfaces, called calenders. As the paper sheet passes through these calendars, it is subjected to great pressure, which causes it to have a smooth glazed surface. It is then wound upon reels and is ready for use.

PYROXYLIN COMPOSITIONS

In the discussion of explosive materials (Chapter XVII) the process of nitrating cellulose is fully described. In the nitrocellulose compounds used for explosive purposes (q. v.), the nitrogen content of the products represent generally the highest nitration possible. Nitrocelluloses of this class are practically insoluble in ether-alcohol mixtures, and are useful for explosive purposes only. For other uses it has been found convenient to prepare nitrated celluloses of lower nitrogen content. To such products a variety of names have been given, such as "pyrocollodion," "collodion," "photo cotton" and "pyroxylin." The latter term may be used to designate in a general way those nitrated celluloses which are soluble in alcohol-ether, amyl acetate, and wood alcohol, and which have a low nitrogen content, the latter varying from 10.5 to 12.2 per cent. The use of pyroxylin in artificial silk manufacture is referred to below. As a constituent of lacquers, imitation leather, waterproofing compositions, celluloid, and photographic films, its industrial importance is apparent.

The preparation of pyroxylin of constant composition is difficult on account of the lack of control over the factors of the nitrating process. The solution of pyroxylin in proper solvents, therefore, determines its specific use.

The solvents in use have been classified by Worden (*The Nitrocellulose Industry*, Vol. I) as follows: (1) those which dissolve directly without pressure on the application of heat, such as acetone, methyl acetone (methyl ethyl ketone), and

amyl acetate; (2) those which require heat or pressure, or both, as camphor or naphthol, and which are spoken of as latent solvents; (3) combinations of two or more substances, either of which separately exerts no solvent action, as alcohol-ether, calcium chloride and ethyl alcohol; and (4) combinations of a solvent with undesirable physical properties (as the hygroscopic nature of acetone) with a non solvent which will overcome the same (amyl alcohol), and thus produce a desirable result.

In order to effect solution, intimate incorporation of the solvent with the pyroxylin is necessary. This is accomplished by the usual types of mechanical agitators, shaking machines, jar mills, etc. The solution thus produced, however, usually contains too much insoluble matter to admit of use without clarification and filtration. Storage in air tight containers will often affect subsidence, so that the clear liquid may be decanted. Artificial filtration through a plate filter press (q. v.), or by means of the centrifugal filter of the DeLaval type (q. v.), is frequently used to yield clear solutions of pyroxylin.

Pyroxylin Lacquers.—The early name given to this class of lacquers was "collodion lacquers." Such lacquers consisted of solutions of pyroxylin in alcohol-ether solvent, and were used for photographic films. In the preparation of protective coatings for metal surfaces, however, other solvents such as acetone, wood alcohol, amyl alcohol, and amyl acetate may be used.

Pyroxylin Waterproofing Composition.—Pyroxylin is also a constituent of waterproofing compositions for use with textiles and paper. The earlier processes simply used a pyroxylin lacquer of light viscosity. The so-called mackintosh cloth (named after the original manufacturer, John Mackintosh)¹ is made waterproof by applying a solution of pyroxylin combined with India rubber and linseed oil. Re-

¹ English Patent 2789 (1859).

cent methods make use of partial mercerization (softening of cellulose by alkalis) and then treatment with pyroxylin solutions which generally contain castor oil or other non-drying oils in order to give extreme flexibility.

Celluloid.—Under the general name of pyroxylin plastics is included the manufacture of celluloid. The latter is essentially a solution of pyroxylin in camphor, the important steps in the process being heat and pressure. Originally the process consisted of mixing 1 part of finely pulverized camphor to 2 parts of moistened pyroxylin, subjecting the mixture to pressure in a hydraulic press, and drying in such a way as to prevent the evaporation of the camphor. It was then placed in a mould, heated by steam to 80° – 150° C. and again subjected to hydraulic pressure. By this combination of heat and pressure the camphor was liquefied and it permeated the pyroxylin, dissolving the latter into a homogeneous body, which upon cooling solidified into a cellulose-like substance, to which the name of celluloid was given.

The original dry process has, however, given way almost entirely to the wet process, in which moist pyroxylin and camphor are first ground together, then alcohol is sprinkled upon the mixture so as to dissolve the camphor, and after allowing the mixture to become thoroughly uniform the mass is welded into a homogeneous mass by heat and pressure.

Although celluloid is a compound of camphor and nitrocellulose, it is not an explosive. It burns readily, volatilizing the camphor and giving off much free carbon. It is soluble in acids, in most of the pyroxylin solvents, and in concentrated solutions of alkalis. Its tensile strength is about the same as that of wood. It is a poor conductor of electricity and heat. The ignition temperature of properly made celluloid is about 350° C. The analyses of 3 commercial celluloids are given in the statement below:¹

¹ *Z. angew. Chem.*, 19, 1378 (1906).

| | No. 1 | No. 2 | No. 3 |
|-----------------------------------|-------|-------|-------|
| Nitrocellulose per cent | 64.89 | 73.40 | 71.80 |
| Camphor “ | 32.86 | 24.30 | 27.00 |
| Other material “ | 2.25 | 1.90 | 1.50 |

VISCOSE PREPARATIONS

The use of viscose in the artificial silk industry is referred to below and a brief description of the composition of viscose and its method of preparation will be given. A simplified method for making a solution of viscose¹ consists in immersing sheets of paper in a 24 per cent solution of sodium hydroxide at 40–50° C. until thoroughly soaked. The excess liquid is then pressed out until the weight is twice the original weight of the paper. This mass is dried at 20° C. and next digested for 3 to 8 hours with a mixture of gasoline and carbon disulphide (20:1), using 500 grains of the mixture for each kilogram of paper taken. From the resulting sodium cellulose thiocarbonate (sulphocarbonate) the liquid is carefully drawn off (without disturbing the sheets), after which warm water (not above 40° C.) is slowly added, using about 6 liters per kilogram of paper taken. This will yield a 14 to 16 per cent aqueous solution of viscose from which the viscose may be precipitated by adding a 10 per cent alcoholic solution of a mineral acid or by adding a saturated salt (NaCl) solution. The pure viscose thus obtained is again soluble in water.

The chief characteristic of such a viscose solution is its tendency to decompose when exposed to the air, the carbon disulphide evaporating and the cellulose, intermingled with sodium hydroxide, remaining as a solid. To the cellulose thus regenerated from a viscose solution, which constitutes the material used in plastics of various kinds, the name viscid is given.

¹ Senenov: *J. Russ. Phys. Chem. Soc.*, **44**, 339 (1912).

The chief uses of viscose aside from its use in artificial filaments are in the sizing of paper, in the manufacture of special wall papers, and as a filler in the textile industry. Some measure of success has also been obtained in the use of viscose for artificial leather fabrics. Experiments carried on in the writer's laboratory show the possibility of using viscose in combination with pigments for a cold water paint and of utilizing the decomposition of viscose solutions for insecticidal purposes. The use of viscose will undoubtedly be extended.

ARTIFICIAL FILAMENTS

The use of cellulose for artificial filaments is based upon the structure of silk fibers. The latter are entirely devoid of cellular structure, being formed from the fluids secreted by the glands of the silkworm. These fluids have the peculiar property of coagulating or hardening when brought into contact with the air. The natural suggestion, accordingly, follows, that it is only necessary "to project a liquid of known viscosity and total solids through orifices of a desired diameter and thus form filaments which, like those of natural silk, must be insoluble in water and of sufficient strength and elasticity to admit of spinning and weaving without serious deterioration."¹

The manufacture of artificial silk has not entirely accomplished the objects above sought, its main defect being the lack of strength and flexibility of the artificial fibers. The bright luster and softness of artificial silk have nevertheless made it an important article of commerce. It is estimated that the annual production for 1909 was about 9,000,000 pounds.

Three classes of artificial silks are being commercially produced: (1) the nitrocellulose silks, (2) the silks made by the ammoniacal copper oxide process, and (3) the viscose silks.

¹ Worden: Nitrocellulose Industry, Vol. 1, p. 454.

Many processes have been proposed for the manufacture of the *nitrocellulose silks*. The Chardonnet process may be regarded as the pioneer method and of chief industrial importance in the production of this class of artificial filaments. The material used in this process consists of pyroxylin (q. v.), which is the name given to nitrocellulose of low nitrogen content. To produce the weavable material a solution consisting of 100 gms. of pyroxylin, 10 to 20 gms. of metallic chlorides (iron, chromium, manganese, or tin) and 0.2 grams of an oxidizable base, such as quinine, aniline, or rosaniline in alcohol-ether mixture, is employed. This gives a viscous liquid which, by forcing through an orifice of about 0.5 millimeter, is made into a thread or filament. By means of cold water the filament is coagulated on the exterior and then drawn or spun out into a fraction of its original size and, after complete solidification, it is reeled on cylinders. It is next subjected to a process of denitration to reduce its inflammability, which consists in maintaining the fibers in a bath of nitric acid (sp. gr. 1.32) at 30–35° C. until the fibers begin to soften. After drying, the filaments are ready for weaving. By the use of the nitric acid bath it has been found possible to eliminate the use of metallic chlorides and alkalis. Another method in use in the preparation of nitrocellulose filaments is the Lehner¹ process, which uses a 10 per cent pyroxylin solution containing mineral acids together with resins, oils, and alkaline salts.

The manufacture of silks by the *ammoniacal copper oxide process* has been undertaken on a large scale by the Vereinigte Glanzstoff-Fabriken at Elberfeld, Germany (these filaments are often described under the name of "Glanzstoff silks"), the annual production being about three million pounds. The method employed consists first in the treatment of cellulose by a solution of sodium hydroxide and sodium carbonate

¹ Worden: The Nitrocellulose Industry, Vol. 1, p. 471; also *Chem. Eng.*, 15, 160 (1912).

under a pressure of two and one-half atmospheres for three and one-half hours, after which it is washed, bleached and dried. It is next triturated with finely divided crystallized copper sulphate and then treated with ammonium hydroxide. This produces a viscous solution which is projected in threads into a bath of acid, alkaline glycerol, sodium chloride, or sodium bisulphate, to remove the copper. After the careful washing out of the copper and other salts and their recovery, the filaments are dried and are ready for use.

The viscose silks are among the more important recent developments in the manufacture of artificial filaments, the output for 1909 being about one million pounds. The name viscose was given to cellulose sulphocarbonate by Cross, Bevan, and Beadle in 1892. Its preparation from paper has been described above, but cotton or other cellulose materials may also be used. For the formation of threads, a homogeneous solution of viscose is projected through suitable orifices into a setting or fixing solution consisting of a mixture of acids to neutralize the excess sodium hydroxide. After subjecting it to heat and other mechanical processes the filaments are ready for weaving.

ETHYL ALCOHOL FROM SAWDUST

The manufacture of ethyl alcohol from sawdust, while a recently developed industry, is based upon facts known for some time. As early as 1819, Bracconet showed that the action of sulphuric acid on wood produced grape sugar which could be fermented so as to yield alcohol. Recently experiments have shown that sulphurous acid has a like effect and, as already described, an attempt has been made in Sweden to utilize the waste liquor obtained from the sulphite processes of paper manufacture. In the United States several plants have been erected to utilize sawdust for the manufacture of ethyl alcohol.

The process in general may be described as follows: The

sawdust obtained from nearby sawmills, is put into a digester with a predetermined amount of water and sulphurous acid. The digester is closed and sealed and heat is applied until the pressure on the inside reaches about 100 pounds. It is maintained at this pressure for a sufficient length of time to convert a portion of the cellulose in the wood dextrin and glucose. The heat is then cut off and the unused sulphurous acid is reclaimed. The converted sawdust is then brought over to the mash tank where its acidity is neutralized, after which it is fermented and distilled in the same way as an ordinary grain mash is treated in the manufacture of whiskey. In some cases the converted sawdust is first compressed to extract the water and solutions of sugar, and the latter liquid only is subjected to fermentation and distillation. The tailings, or total solids, from either process are similarly treated and are used for various purposes. In France and England a small amount of the waste materials from sugar refineries is incorporated with the dry material and the resulting product is used as a food for cattle.

The results obtained in general show that it is possible to produce the following yields for each 3200 pounds of green sawdust, which is theoretically equivalent to about one ton of absolutely dry wood.

30 gallons of 188° proof alcohol.

76 pounds of acetic acid.

$\frac{3}{4}$ ton of residue used as stock food.

Inasmuch as the weight of a thousand feet (board measure) of lumber is approximately one and one-fourth tons and since the wood waste of the United States is estimated in millions of feet, it is readily seen to what extent this process is capable of development. A number of plants have been erected some of which have been failures, while others are in operation. For a general review of this subject, the student is referred to an editorial in the *Journal of Industrial and Engineering Chemistry*, 4, 477 (1912).

REFERENCES

I

- BUTLER: The Story of Paper Making.
CROSS AND BEVAN: Cellulose.
CROSS AND BEVAN: Researches on Cellulose, 3 Vols.
CROSS AND BEVAN: Text-book of Paper-Making.
CROSS, BEVAN AND SINDALL: Wood Pulp and its Uses.
GRIFFITH AND LITTLE: Chemistry of Paper Making.
MARGÖSCHES: Die Viskose.
SCHWALBE: Chemie der Zellulose.
SPICER: The Paper Trade.
STEVENS: The Paper Mill Chemist.
SUEVERN: Artificial Silk; its Production, Qualities and Use.
WORDEN: The Nitrocellulose Industry.

II

- Illustrated Descriptions of Paper Mills. *Eng. Rec.*, **42**, 560 (1900);
Eng. Rec., **45**, 410 (1902).
Symposium on Camphor, Celluloid, etc. *J. Soc. Chem. Ind.*, **26**, 380-
388 (1907).
PRITZKOW: Present Status of the Disposal of Sulphite Liquor in Ger-
many. *Eng. Rec.*, **62**, 468 (1910).
SCHWALBE: Cellulose. *J. Frank. Inst.*, **170**, 371 (1910).
TRAQUAIR: Function of Starch in the Manufacture of Paper. *J. Soc.*
Chem. Ind., **29**, 323 (1910).
Alcohol from Sulphite Cellulose in Sweden. *Chem. Ind.*, **34**, 14 (1911).
Celluloid Industry of Japan. *J. Soc. Chem. Ind.*, **30**, 1008 (1911).
EICHENGRÜN: Preparation of Non-Inflammable Celluloid. *J. Soc. Chem.*
Ind., **30**, 413 (1912).
LITTLE: The Basis of Quality in Paper. *Chem. Eng.*, **13**, 87 (1911).
New Paper Specifications for the Government Printing Office. *Eng.*
News, **67**, 490 (1912).
REMINGTON: Paper Makers' Clays. *J. Ind. Eng. Chem.*, **3**, 550 (1911).
REMINGTON: Sizing of Paper with Resin Compounds. *J. Ind. Eng.*
Chem., **3**, 466 (1911).
BULLARD: Scientific Control in Sulphite Pulp Manufacture. *Proc. 8th*
Inter. Congress Appl. Chem. **13**, 77 (1912).
FORRESTER: The Recovery of Waste Sulphite Liquors. *Paper*, **61**, 15
(1912).

- LITTLE: Progress of the Chemistry of Paper Making. *Paper*, **6**, 25 (1912).
- SPIRO: The Technical Development of the Manufacture of Sulphite Pulp. *Chem. Zeit.*, **36**, 494 (1912).
- RENMAN: Cellulose from Wood and Recovery of By-Products. *J. Soc. Chem. Ind.*, **31**, 183 (1912).
- SUTERMEISTER: The Consumption of Caustic Soda in Cooking Wood and the Influence of this Consumption on the Yield and Bleaching Properties of the Fiber Produced. *Proc. 8th Inter. Congr. Appl. Chem.*, **13**, 265 (1912).
- BEADLE and STEVENS: Contributions to the Technology of the Paper Industry. *J. Soc. Chem. Ind.*, **32**, 174 (1913).

CHAPTER XVII

EXPLOSIVE MATERIALS

AN explosion is said to take place when a *sudden* increase of volume occurs. This may be due to the expansion of gases by heat alone, as in boiler explosions; to the formation of gaseous materials out of substances originally solid or liquid by chemical rearrangement, as in nitroglycerin or gun-cotton explosions; to the interaction of solid or liquid substances producing gaseous materials, as in the case of black powder; or to the decomposition of a substance into constituent parts, as in the case of nitrogen iodide. In many cases the force of the explosion is augmented by the heat of reaction or decomposition.

Even when a natural contraction of volume takes place by interaction, the intense heat may cause an explosion due to temporary expansion of the products. For example, water of relatively negligible volume is produced by the union of hydrogen and oxygen, yet the heat produced is so intense that a violent explosion results.

Explosions are initiated by mechanical shock or by increase of temperature, or both. If dry nitrogen iodide, a black powder of the probable constitution, $N_2H_3I_3$, is subjected to a very slight shock, it decomposes into gaseous constituents according to the equations:

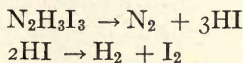

If, on the other hand, mercuric fulminate, $HgC_2H_2O_2$, is subjected to a temperature of $190^\circ C.$, decomposition into mercury and a mixture of gases takes place. The formation of

the gas may be sufficiently rapid to be called explosive, or if confined, the walls of the confining vessel may finally be ruptured, with resulting explosive expansion.

The exact methods of initiating an explosive reaction vary greatly according to the explosive materials used. Three general types may be described: (1) a direct application of heat, as in firing by means of heated platinum wire, by fuses, etc.; (2) by direct shock, as in the use of the percussion caps by means of which the old style rifles were fired and the modern cartridges are exploded; and (3) by detonation. This last term may be explained somewhat in detail. It is well known that in some cases glass globes which are capable of withstanding strong blows are shattered by the vibration of a particular note. The same principle applies in certain cases to the initiating of an explosion by a second or less powerful explosion. Inasmuch as the more gentle explosive material sets off reaction more readily than a more powerful material, it is thought that the explosive reaction in the case of detonation consists of a process of setting up certain vibrations which are capable of decomposing some bodies without the aid of heat.

That these methods may produce different results in the same explosive material, as well as furnish an example of certain differences between rapid combustion, explosion, and detonation, is well illustrated by the behavior of dynamite. When a piece of unconfined dynamite is lighted with a fuse without any cap attached, it will burn quickly without exploding, producing a dense smoke which has a disagreeable smell and causes violent headaches. This is simple combustion. When a piece of dynamite is confined and lighted in the same way it will explode but will emit similar fumes. When a piece of confined dynamite is fired by a very weak single force cap the dynamite will explode vigorously with some smoke. When a triple force cap is used the dynamite will explode, even when unconfined, with great force

and very little smoke. The latter represents the process of detonation. It will be noted that the three methods produce results differing not only in rapidity and consequent violence, but also in the products of reaction.

Explosive materials used industrially may be classified as follows: ¹

- I. Explosive mixtures
 1. Nitrate class
 2. Chlorate class
- II. Explosive compounds
 1. Nitro substitution products
 2. Nitric esters
 - A. Guncotton
 - B. Nitroglycerin
 - a. Dynamite with inert base
 - b. Dynamite with combustible base
 - c. Dynamite with explosive base
 3. Sprengel class
 4. Fulminate class
 5. Smokeless powders

EXPLOSIVE MIXTURES

An explosive mixture consists of a mechanical incorporation of substances, of which one at least must be combustible and another a supporter of combustion.

NITRATE CLASS

The best example of the nitrate class is black gunpowder, which is composed as follows:

| | |
|------------------------|----------|
| Potassium nitrate..... | 75 parts |
| Carbon..... | 15 parts |
| Sulphur | 10 parts |

The manufacture of gunpowder involves the following proc-

¹ Walke: Lectures on Explosives, p. 26.

esses: (1) mixing, (2) incorporating, (3) disintegrating, (4) pressing, (5) granulating, (6) dusting, (7) glazing, (8) second dusting, (9) drying, (10) finishing.

The mixing of refined and finely powdered potassium nitrate, distilled sulphur, and willow or alder charcoal is done in a revolving drum with fork shaped arms mounted upon an axle passing through its center. This mixture, known as the "green" charge, is next transferred to the "incorporating mill," where it is spread evenly over the bed of the mill with a wooden rake. A little water is next added, and the mass thoroughly incorporated into a cake by two cylindrical edge runners. The action of the runners is similar to the effect of a pestle and mortar, and is continued for four or five hours. The incorporated or "mill" cake is next disintegrated by passing between two pairs of rollers and collecting the broken pieces in small magazines. From the magazines it goes to the hydraulic press and is formed into sheets which are then granulated by being passed through several pairs of rollers fitted with teeth of various sizes. Screens allow the fine material to fall through while the coarser pieces go through other rolls. The granulated powder is next passed through the dusting rolls, which consist of cylindrical drums of dusting cloth (18 to 56 meshes to the inch), where the dust adhering to the grains is removed. The dust-free grains are glazed by being shaken with a small quantity of graphite or plumbago ($\frac{1}{2}$ ounce to 100 lbs. of powder), and are again dusted. In the last stage the powder is placed on trays with canvas bottoms and dried in a room kept at 120° to 145° F., after which the dusting process is again repeated.

Properties of Gunpowder.—The specific gravity of common gunpowder ranges from 1.50 to 1.80. It has a dark gray color, and a smooth glossy appearance. It is hard and angular. It absorbs moisture from the air with resulting deterioration. When heated to 316° C. it explodes. Percussion and detonation may also explode it.

The explosive reaction of gunpowder is usually given as follows: $2\text{KNO}_3 + 3\text{C} + \text{S} \rightarrow \text{K}_2\text{S} + 3\text{CO}_2 + 2\text{N}$. The analysis of the products of explosion, however, shows the presence of carbonates, sulphates, hyposulphites, sulphocyanates, carbon monoxide, hydrogen sulphide, etc. The results of investigators show that the combustion of gunpowder takes place in two stages:

1. A process of oxidation with the formation of potassium sulphate, carbonic acid, and nitrogen.
2. A process of reduction, free carbon and sulphur reacting with the products of the first stage and forming potassium sulphide.

The manner in which gunpowder explodes is related to certain physical factors such as density and size of grain. Since the combustion proceeds in successive layers over the surface, the size of the powder grains will regulate the rate of combustion. For example, a fine grained powder will require but a short time for combustion from the surface to the center of each grain, giving off the gas at once and resulting in great initial pressure, while a large grained powder will give a more moderate initial pressure but will continue to give it as combustion proceeds. But as the surface of the grain decreases, the amount of gas diminishes and the pressure grows less and less as combustion proceeds. To overcome this and keep up the initial pressure when large charges are used, the powder grains are perforated with cylindrical channels, so that combustion may proceed on the inside and outside of the grain at the same time, thus increasing the surface and the corresponding volume of gases liberated during a given interval of time.

Gunpowder is manufactured under various names, such as the black powder above described, brown powder made from straw charcoal so carbonized as not to destroy all carbohydrate, and amide powder in which the sulphur is replaced by ammonium nitrate.

CHLORATE CLASS

Chlorate powders are those in which potassium chlorate is substituted for potassium nitrate in the explosive mixture. The essential advantage of this class of powders consists in the greater amount of heat generated by chlorates, this increasing the force of the reaction. The products of explosion are as follows:

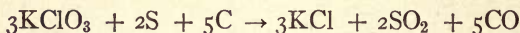

The general conclusion of authorities on explosives is that the chlorate powders are liable to suffer deterioration and decomposition under a variety of circumstances and from slight causes. Among the latter are the presence of acids, friction, percussion, and exposure to moist and dry air alternately. Various attempts have been made to lessen the danger connected with the manufacture and use of chlorate powders by substitution of ingredients which decrease the sensibility to shock and spontaneous decomposition. Such a powder is asphaltine, made from pulverized whole wheat or barley bran, impregnated with a mixture of potassium chlorate, potassium nitrate and potassium sulphate together with some coloring matter, such as fuchsine. Flour, starch, and sugar are often substituted for bran in powders of this type. It is claimed by manufacturers that such powders are stable, will not deteriorate from storage, and will not be ignited by friction and ordinary percussion. Chlorate powders have recently succeeded in passing the severe tests prescribed by the English Government. Such powders are usually protected from moisture by embedding the chlorate masses in a plastic, insoluble matrix of oils and fats.

EXPLOSIVE COMPOUNDS

Explosives of this type consist of either a single compound which is readily decomposed, or of a mixture of compounds

which assist in decomposition by certain oxidation processes as below described.

NITRO SUBSTITUTION PRODUCTS

The best example of this class of explosive compounds is picric acid or tri-nitro-phenol. It is made by the action of nitric acid on carbolic acid (phenol) according to the equation:

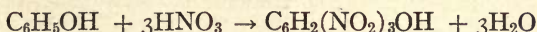

On an industrial scale it is manufactured by melting carbolic acid, mixing it with strong sulphuric acid, diluting with water, and afterwards running it slowly into a stone tank containing nitric acid. On cooling, the crude picric acid crystallizes out and is subsequently purified by recrystallization. Picric acid is a yellow crystalline solid. When heated it burns quickly with a bright flame but may be exploded by detonation or by a blow. Its explosion is represented by the equation:

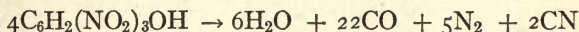

Since the maximum gas volume from the constituents is not so obtained and the gaseous products are very poisonous, picric acid is more usually a constituent of explosive mixtures containing oxidizing agents. Examples of such mixtures are the ammonium picrate powders used in France, and Abel's powders in England. The former is composed of:

| | |
|-------------------|----------|
| Ammonium picrate | 54 parts |
| Potassium nitrate | 46 parts |

Its decomposition is expressed by the following reactions:

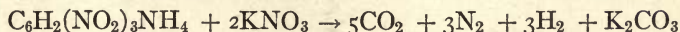

Abel's powder is manufactured in the same way as gunpowder but it is several times as powerful. Its composition is as follows:

| | |
|-------------------|-------------|
| Ammonium picrate | 42.18 parts |
| Potassium nitrate | 53.97 " |
| Charcoal | 3.87 " |

NITRIC ESTER CLASS

Guncotton is a nitric ester of cellulose and may be considered as the type of the nitric ester class of explosive compounds. If cellulose, whose structure is not fully known, be represented for convenience by the formula $C_{12}H_{20}O_{10}$ or $C_{12}H_{14}O_4(OH)_6$, then the corresponding ester with nitric acid will be $C_{12}H_{14}O_4(ONO_2)_6$, which is the formula generally used for guncotton, its formation being represented by the equation:

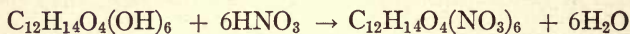

The nitration of cellulose does not always produce the hexanitrate of cellulose, a series of lower nitrates, such as the trinitrate, tetranitrate and pentanitrate being used in the manufacture of certain classes of explosives, as in the smokeless powder made by the United States Government. The first step in the manufacture of guncotton consists of the cleansing of the cellulose (cotton) by treating it with a boiling solution of caustic potash (specific gravity 1.02), washing with water, and drying thoroughly at 86° C. It is next picked apart and untangled and further dried by hot air at 107° C. When cool it is dipped into a mixture of 1 part by weight of nitric acid (specific gravity 1.5) to three parts by weight of sulphuric acid (specific gravity 1.845). During the process the mixture of acids is kept at a temperature below 21° C. by circulating cold water through coils in the mixing vessel. The excess acid is next pressed out and the cotton is placed in stoneware digestion crocks which are covered, placed in a cooling trough, and left overnight. The next step consists in removing the free acid by means of centrifugal machines and thoroughly washing with water. After draining, the entire mass is boiled in a dilute solution of sodium carbonate, washed, and drained. It next passes through pulpers; or rag engines, similar to those used in paper mills (see Chapter XVI)

and is cut into fine pieces. It is then agitated with water for several days. After it is thoroughly washed it is treated with a solution of caustic soda containing lime of chalk in suspension and the entire mass is fed into a hydraulic press and pressed into blocks about 2.9 inches square and two inches high. It is subsequently passed to the final press and when completed contains about 14 per cent moisture, although for safe keeping the percentage of moisture is generally increased to 35 per cent by soaking in water.

Properties of Guncotton.—Fibrous guncotton resembles an ordinary cotton in appearance, but when examined with the polarizing microscope it is dull, while cotton is bright and iridescent. It is insoluble in water and in a mixture of ether and alcohol, but soluble in ethyl acetate, in acetone and caustic alkali. Its density varies from 0.3 in the fibrous state to 1.5 in compressed form. When heated to 180° C. it explodes, the explosive reaction being represented by the equation:

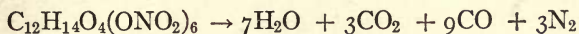

It is not easily exploded by percussion and requires for its explosion a detonation of mercury fulminate.

Nitroglycerin.—The action of nitric acid on glycerin, a tri-hydric alcohol, gives rise to a replacement of the hydroxyl group by an acid radical; hence the product is a true ester.¹ The reaction may be represented as follows:

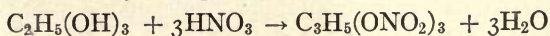

In preparing nitroglycerin on a commercial scale a mixture of sulphuric and nitric acids is used in the proportion of 1 part glycerin to 8 parts of mixture of nitric and sulphuric acids (3 parts nitric and 5 parts sulphuric). The purest and most concentrated acids are used. The function of the sulphuric acid is to absorb the water formed in the above

¹ For a good historical sketch of the manufacture of nitroglycerin the student is referred to Walke: Lectures on Explosives, pp. 269-271.

reaction. This absorption (the formation of hydrates of sulphuric acid) is attended with the liberation of large quantities of heat which must be removed by a cooling agent.

The apparatus for the manufacture of nitroglycerin consists of an acid tank made of cast iron, a wooden lead-lined glycerin tank, a water jacketed cast iron converter, provided with lead cooling coils and an agitator, and lead-lined wooden discharge tanks and separators.

During the process of manufacture, the mixture of acids is first run into the converter, the cooling water is next set in circulation and the agitator started, after which the glycerin is introduced either in fine streams from a perforated pipe or as a spray by means of an air injector. The temperature is never allowed to exceed 30° C. When nitration is complete the nitroglycerin, being lighter than the mixture of excess acids, collects on the top and is separated in a conical shaped vessel similar to the usual separatory funnel. It is next discharged into washing tanks containing large volumes of water, where it is agitated by compressed air admitted from below, the water run off, and a solution of sodium carbonate used for washing. After a final washing with water it is filtered through wire gauze disks and felt, after which it is ready for use.

Properties of Nitroglycerin.—Nitroglycerin is an oily liquid with a specific gravity of 1.60 at 60° F. (15° C.). It may be transparent, but more generally is opaque and of light yellow color. It is insoluble in cold water, but soluble in the organic solvents such as methyl, ethyl, and amyl alcohols, ether, chloroform, carbon disulphide, etc. It is liable to chemical decomposition by dilute sulphuric acid, alkalies, and alkaline sulphides. Transparent nitroglycerin becomes a solid at 37° F. (3° C.), while the opaque variety solidifies at 10° F. (-12° C.) the specific gravity being 1.73 at this temperature.

In general it may be said that nitroglycerin freezes when

exposed to temperatures from 37° F. to 14° F. (3° to - 10° C.) and that the thawing temperature is about 42° F. (6° C.), although in actual practice it has been found convenient to use temperatures ranging from 65° F. to 75° F. (16 to 24° C.) but not exceeding 80° F. (27° C.)

It explodes by percussion or by means of detonators, the equation of decomposition being represented by

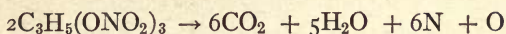

It will be seen from this reaction that nitroglycerin has excess oxygen. Owing to the fact that a portion of the nitroglycerin burns instead of exploding, and for other causes, some oxides of nitrogen are generally given off when an explosion of the nitroglycerin takes place.

Aside from "shooting" oil wells in order to increase the flow of oil, very little use is made of nitroglycerin in its liquid form. Instead it is mixed with some suitable absorbing medium to form the dynamite of commerce.

Dynamite with an Inert Base.—This constitutes the original form devised by the inventor of dynamite, Nobel, in 1866. In his patent specifications he includes charcoal, silica, and paper among the inexplusive materials used for absorbing nitroglycerin. Quite generally this type of dynamite employs infusorial earth for the absorbing medium. This is the silicious skeleton or fossil remains of microscopic organisms, known as infusoria and diatoms, and goes under various names such as kieselguhr, tripoli, silicious earth, diatomaceous earth, etc. The process of manufacture consists of the preparation of the base or "dope," the absorption of the nitroglycerin by the base, and the making of the "sticks" or cartridges.

For use in dynamite, infusorial earth is usually calcined in order to remove the moisture and organic matter and then crushed between rolls and sieved. The moisture content of infusorial earth must be kept below 0.5 per cent, otherwise

the nitroglycerin will exude. Pure dry infusorial earth will absorb three times its own weight of nitroglycerin.

The mixture consisting of 50 pounds of base and 150 pounds of nitroglycerin is thoroughly kneaded in a wooden trough, then rubbed through wire sieves (3 mesh and 7 mesh per linear inch). It is next conveyed to the press house, where it is made into cartridges or cylinders about the size of the drill holes for charging in quarrying. The cartridges are wrapped in paraffined paper as a protection against moisture.

Dynamite is a plastic substance of a yellowish or dirty color, with a specific gravity of 1.4 to 1.5. It possesses the general properties of nitroglycerin but it is less sensitive than liquid nitroglycerin and therefore safer for handling and transportation. This property is dependent upon the presence of interstices and pores allowing it to be compressed and preventing rigidity.

Dynamite with a Combustible Base.—In order to utilize the excess of oxygen formed in the explosive reaction of liquid nitroglycerin, as well as of dynamite with an inert base, it has been found advantageous for some purposes to use the carbon in the form of carbonized cork for the absorbent. Carbodynamite is an example of this class. It consists of 90 parts of nitroglycerin and 10 parts of carbon with 1.5 per cent of ammonium carbonate added. The explosive reaction is represented by the following equation:

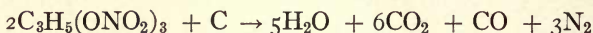

Dynamite with an Explosive Base.—This type of dynamite may contain a base which may be (1) an explosive mixture of the nitrate or chlorate class, or (2) an explosive compound such as have been above described under this head. The composition of a number of these powders will be given.¹

¹ Wisser: Explosive Materials, pp. 102-103.

Dynamite No. 2

| | |
|-------------------|----------|
| Nitroglycerin | 18 parts |
| Potassium nitrate | 71 " |
| Charcoal | 100 " |
| Paraffin | 1 " |

Giant Powder No. 2

| | |
|------------------|----------|
| Nitroglycerin | 40 parts |
| Sodium nitrate | 40 " |
| Infusorial earth | 8 " |
| Sulphur | 6 " |
| Resin | 6 " |

Vulcan Powder

| | |
|----------------|----------|
| Nitroglycerin | 30 parts |
| Sodium nitrate | 52.5 " |
| Charcoal | 10.5 " |
| Sulphur | 7 " |

Atlas A Powder

| | |
|---------------------|----------|
| Nitroglycerin | 75 parts |
| Sodium nitrate | 2 " |
| Magnesium carbonate | 2 " |
| Wood fiber | 21 " |

Hercules Powder

| | |
|---------------------|----------|
| Nitroglycerin | 40 parts |
| Potassium chlorate | 3.34 " |
| Magnesium carbonate | 10 " |
| Potassium nitrate | 31 " |
| Sugar | 15.66 " |

SPRENGEL CLASS

The object of these powders proposed by Dr. Herman Sprengel is to furnish mixtures of maximum safety for handling, transportation, and storage. This is accomplished by keeping the constituents separate and mixing them as required, the constituents being themselves non-explosives. The mixture in principle consists of an oxidizing agent, such as nitrates, chlorates, nitric acid, and a combustible agent, such as nitro substitution products, carbon disulphide, and petroleum.

FULMINATE CLASS

This class of materials is largely employed in cap and fuse compositions and in detonators. The representative type of this class is *mercury fulminate*, which is regarded as a metallic salt of the hypothetical fulminic acid, $\text{H}_2\text{C}_2\text{N}_2\text{O}_2$. The latter has an intermediate composition between cyanic acid, HCNO , and cyanuric acid $\text{H}_3\text{C}_3\text{N}_3\text{O}_3$, and is generally regarded as an iso-nitroso compound. The following equations represent the formation of mercury fulminate:

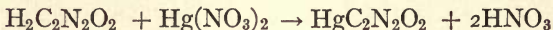
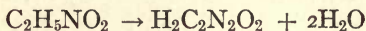
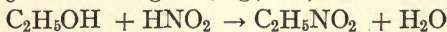
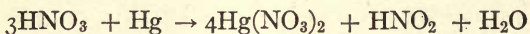

In the manufacture of mercury fulminate on a commercial scale one part of mercury is first dissolved in 10 parts of concentrated nitric acid by the aid of gentle heat. At a temperature of 54°C . the solution is poured into 8.3 parts of alcohol (specific gravity 0.83). This reaction is quite violent and is attended by the evolution of vapors, which are condensed and used subsequently instead of pure alcohol. The resulting fulminate is washed with water, dried in the open

air, until it contains about 15 per cent moisture, and then stored under water or packed in papier-mache boxes.

Properties of Mercury Fulminate.—The color of mercury fulminate is white or gray, the latter being due to the presence of finely divided metallic mercury. It is crystalline in form and has a density of 4.42. Its most marked characteristic is its sensitiveness and liability to decomposition. It explodes when struck, or when touched by a red hot wire, or when heated slowly to 152° C. The reaction of decomposition is as follows:

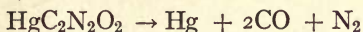

In the latter equation it may be noted that none of the products formed is capable of dissociation at high temperatures and consequently no recombination will take place. Hence, aside from the condensation of the mercury vapor, the violence of the explosion is entirely initial and is not retarded by the usual tendencies toward the reduction of the expansion due to formation of other compounds in cooling. To reduce the brusqueness of the explosion various substances such as potassium nitrate, glass, etc., are usually added.

The mixture in percussion caps for firing gunpowder consists of potassium chlorate, mercury fulminate and antimony sulphide. When used in connection with electric batteries, some sulphur and guncotton are added to the above. Detonators containing 3 grains of mercury fulminate are known as single strength caps, while double strength caps contain six grains, etc.

SMOKELESS POWDERS

The manufacture of this class of explosives is dependent upon reactions which yield gaseous products only. Obviously either guncotton or nitroglycerin will comply with this requirement, but some method for controlling the violence of explosion, as well as for providing safety, must be

applied. This object has been successfully accomplished by the use of solvents which act as deterrents.

Cordite.—The manufacture of cordite may be taken as a typical example of this class of powders. The composition of cordite is as follows:

| | |
|---------------|----------|
| Nitroglycerin | 58 parts |
| Guncotton | 37 “ |
| Vaseline | 5 “ |

The guncotton is first dried so that its moisture content does not exceed 0.1 per cent. It is then placed in a brass lined box and the nitroglycerin poured over it and thoroughly mixed, after which it is transferred to a kneading machine and the solvent, acetone, added. It is next kneaded for several hours, the machine being water jacketed and the mass kept cool to prevent evaporation of the acetone. Vaseline is next added and the mass again kneaded until thorough incorporation has taken place. It is next pressed into a mould to free it from air and finally is compressed into a cake of the desired density. It is then forced through dies of various sizes and reeled upon sheet metal drums, after which it is dried at a temperature of 38° C. for a number of days. It is next “blended,” i. e., strands for various reels are woven into ropes of many strands. Finally it is cut into convenient lengths and completely dried.

Properties of Cordite.—The color of cordite varies from light to dark brown. It is of a horn-like consistency, and when ignited in the open air burns fiercely without exploding. This burning takes place from the surface to the center of the cord and as in the prismatic powders, the rate of combustion can be regulated by the size of the surface. It has been found extremely stable under various climatic conditions, resisting exposure to rain, snow, and tropical heat, without serious impairment. The explosive reaction is represented by the following equation:

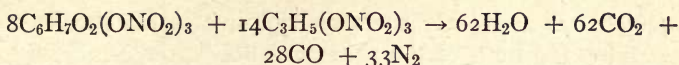

Other Smokeless Powders.—Among other smokeless powders in use are the W. A. powder, made by the American Smokeless Powder Company, which consists of a mixture of guncotton, nitroglycerin, acetone, nitrates, and an organic deterrent, explosive gelatin, a mixture of guncotton and nitroglycerin to which camphor is sometimes added; and the Italian powder, a mixture of diphenylamine $\text{NH}(\text{C}_6\text{H}_5)_2$ dissolved in nitroglycerin and mixed with soluble guncotton. Ammonium picrate is also a constituent of some smokeless powders.

Attention is called to the fact that while nitrocellulose is a constituent of many smokeless powders it is so used generally in the form of the lower nitrates of cellulose, known as soluble cotton, which differs from guncotton proper not only by its lower nitrogen content, but also by its solubility in an alcohol ether mixture. The smokeless powder manufactured by the United States Government is made from soluble cotton. Many modifications of the method of manufacture above described are in use. For a fuller description of smokeless powders the student is referred to a series of articles in *Engineering* (London), 70, 751; 71, 345, 689, 757; 72, 25.

ADAPTATION OF EXPLOSIVES TO INDUSTRIAL AND ENGINEERING OPERATIONS

According to the Bureau of the Census, 469,000,000 pounds of explosives were manufactured in the United States in 1909, chiefly for use in engineering, industrial and agricultural operations. This is more than twice the amount produced ten years earlier. The manufacture of explosives has become a highly developed industry and manufacturers now undertake to supply special explosives to meet almost any special condition which may be encountered.

Engineers and other users of explosives should make a careful study both of the characteristics of the established types of explosive mixtures and compounds as outlined in the preceding part of this chapter and with the current advances in the manufacture and adaptation of explosives.

In large engineering projects and in mining operations the selection of suitable explosives from among the many kinds on the market is of fundamental importance. Many explosives suitable for quarry work are unsuitable for use in deep mines or in close workings. In mines and tunnels the character of the gases evolved is obviously of more importance than in open air work and for use in gaseous or dusty coal mines explosives must be so formulated and compounded that the flame temperature and height and duration of flame are reduced enough for comparative safety. Thus on account of varying conditions in the different projects in which explosives are used, some characteristics of explosives are of much importance in certain classes and of very little importance in others.

The potential energy of an explosive may be measured by exploding a small quantity in a bomb calorimeter surrounded by water and determining the energy in the form of heat from the rise in temperature of the water. The method is similar to the determination of calorific power of fuel by burning in compressed oxygen, but the apparatus as described by Hall and Howell ¹ is larger and heavier.

The disruptive effect which bears a close relation to the percussive or shattering force, and the **propulsive effect** which corresponds closely to the heaving or pushing force of the explosive may also be measured by methods outlined by Hall and Howell (*loc. cit.*). The disruptive and propulsive effects of explosives of different types are not quantitatively proportional either to each other or to the total potential energy. Thus if a 40 per cent "straight" nitroglycerin dynamite

¹ Bull. 48, Bureau of Mines.

be taken as 100 in each case, a 40 per cent gelatin dynamite showed a potential energy of 105.7, a disruptive effect of 78.4, and a propulsive effect of 95.8. On this basis of comparison a black blasting powder of 71.6 potential energy showed a disruptive effect of only 6.8 but a propulsive effect of 58.6.

Explosives used in Quarry Operations.—Practically every class and grade of commercial explosive may be used in open air work to meet varying conditions. Black blasting powder, granulated nitroglycerin powder, "straight" nitroglycerin dynamites, low-freezing dynamites commercially rated according to the equivalent percentage of strength of the "straight" nitroglycerin dynamites and ammonium dynamites similarly rated, are all largely used. Blasting gelatin, gelatin dynamites, ammonium nitrate powders containing nitro-substitution compounds, chlorate powders, and the so-called nitro-starch powders, are as yet used to a much smaller extent in quarry work.

Explosives for Mining and Tunnelling Operations.—In driving tunnels, sinking shafts, and in removing hard rock in metal mining, explosives having a high disruptive force are preferable. Here the cost of drilling holes is an important item and it has been found more economical to drill a few holes and to load them with an explosive of high disruptive force than to drill a number of holes for cheaper and weaker explosives. It is however important that explosives used in work of this type should produce the minimum amount of poisonous gases. To meet this combination of requirements, the Bureau of Mines is experimenting with special formulas and modifications of gelatin dynamite. The results of these experiments indicate that the gelatin dynamites should be made with an oxygen excess sufficient to completely oxidize all combustible material present including the wrappers, should be very carefully stored to keep it in proper condition, and should be fired with a strong detonator.

When the explosive has aged to such an extent as to materially decrease its sensitiveness, when weak detonators are used, or when the explosive is used in a frozen or partially frozen condition, a greater quantity of poisonous gases is evolved.

Explosives for use in gaseous or dusty coal mines in addition to possessing the requisite qualities of strength and efficiency in breaking down coal, must be of such a composition as to produce on explosion a relatively short flame of relatively low temperature. This is accomplished by the addition of flame reducing salts, of an excess of carbon, or even of free water.

To determine whether an explosive is satisfactory requires careful testing. Equipment for making such tests has been installed at the Pittsburgh testing station of the United States Bureau of Mines. A charge of the explosive is fired in a large steel cylinder or gallery which may be filled with mixtures of gas and air containing coal dust in any desired proportions and all explosives, in order to be placed on the "*permissible*" list, must pass the gas-and-dust test, when fired in charges of $1\frac{1}{2}$ pounds. It is held that a charge of $1\frac{1}{2}$ pounds per drill hole should never be exceeded in coal mining and that in good practice the charge need not exceed 1 pound, thus providing a greater factor of safety.

The use of explosives which have been officially declared permissible by the United States Bureau of Mines is rapidly increasing throughout the coal mining regions of the country. The amount of such "*permissible explosives*" used in the United States was 8,592,000 pounds in 1909; 11,900,000 pounds in 1910; 13,428,000 pounds in 1911. Investigations on explosives are constantly being carried forward by the Bureau of Mines and further developments in this field may confidently be expected in the near future.

REFERENCES

I

- BRUNSWIG: Explosives, a Synoptic and Critical Treatment of the Literature of the Subject as gathered from Various Sources (Transl. by Munroe and Kibler).
- EISSLER: A Handbook on Modern Explosives.
- EISSLER: The Modern High Explosives.
- GUTMANN: The Manufacture of Explosives, 2 volumes.
- GUTMANN: Progress in Explosives.
- MACDONALD: Historical Papers on Modern Explosives.
- SANFORD: Nitro-Explosives.
- THORPE: Dictionary of Applied Chemistry, Revised Edition, Vol. II.
- WALKE: Lectures on Explosives.
- WEAVER: Military Explosives.
- WISSNER: Explosive Materials.
- WORDEN: Nitrocellulose Industry.
- U. S. Bureau of Mines, Bulletin 15, Investigations of Explosives Used in Coal Mines (contains description of methods used for testing explosives).
- U. S. Geological Survey: Bulletins 383, 423 and 425

II

- BOOTH: Manufacture of High Explosives. *Cassier*, 30, 291 (1906).
- MUNROE: Development in Explosives. *Sci. Am. Sup.*, 62, 25906 (1906).
- MUNROE: Explosives in the United States. *Min and Sci. Press*, 99, 681 (1909).
- MUNROE: Modern Developments in Methods of Testing Explosives. *Proc. U. S. Nav. Inst.*, Sept., 1910.
- RICE: Coal Dust Explosions. U. S. Bureau of Mines, Miner's Circular 3.
- STRAUSS: Stability of Smokeless Powder. *Proc. U. S. Naval Inst.*, 36, 929 (1910).
- DIXIN: Initiation and Propagation of Explosions. *J. Chem. Soc.*, 99, 588 (1911).
- HALL, SNELLING AND HOWELL: Investigations of Explosives Used in Coal Mines. U. S. Bureau of Mines, Bull. 15 (1911).
- HANDY: Dynamite Analysis. *Proc. Eng. Soc. West. Pa.*, 26 (9), 230 (1911).
- COMEY AND HOLMES: Methods for the Determination of the Effective Strength of High Explosives. *Proc. 8th Inter. Congress Appl. Chem.* 25, 217 (1912).

- HALL: Permissible Explosives Tested Prior to January 1, 1912, and Precautions to be taken in their Use. U. S. Bureau of Mines, Miner's Circular 6 (1912).
- MUNROE: The Development of the Explosive Industry in the United States During the Last Three Years. *Proc. 8th Inter. Congress Appl. Chem.*, 25, 245 (1912-13).
- RUTLEDGE AND HALL: The Use of Permissible Explosives. U. S. Bureau of Mines, Bull. 10 (1912).
- SNELLING AND STORM: The Behavior of Nitroglycerin when Heated. U. S. Bureau of Mines, Technical Paper 12 (1912).
- HALL AND HOWELL: Magazines and Thaw Houses for Explosives. U. S. Bureau of Mines, Technical Paper 18 (1912).
- Report of International Commission for Unification of the Testing Methods on the Stability of Explosives. *Proc. 8th Inter. Congress Appl. Chem.*, 25, 305 (1912-13).
- HALL: Permissible Explosives Tested Prior to March, 1913. U. S. Bureau of Mines, Tech. Paper 52 (1913).
- HALL AND HOWELL: The Selection of Explosives Used in Engineering and Mining Operations. U. S. Bureau of Mines, Bull. 48 (1913).
- LEWES: The Testing of Safety Explosives. *J. Roy. Soc. Arts*, 61, 521 (1913).

SUBJECT INDEX

A

- Acetic acid, 97
 Acetone, 389
 Acetylene, manufacture of, 156;
 solubility, 158; (ref.) 166
 Acid, acetic, 97; "eggs," 9; ful-
 minic, 412; number, 340; pyrolig-
 neous, 96-97; tanks, 233; tar,
 317
 Acidity of water, 71
 Air, analysis of, 38, 39; odors in,
 44; purification of, 38, 48; (ref.)
 37, 59, 60; solid particles in, 45;
 use in dessication, 50
 Air compressor, 5, 6
 Air filtration, (ref.) 60
 Air jet lift, 8
 Air, methods for examination of,
 (ref.) 60
 Air nitrate, 56
 Air separators, 12
 Alca plaster, 310; (ref.) 311
 Alcohol, 160; denaturing of, 162;
 methyl, 97; "proof" gallons,
 161; from sawdust, 395; from
 sulphite liquor, 385; (ref.) 165
 Alkali of soil, 76
 Alligatoring of paint surfaces, 358
 Alloys, 225; classification of, 226;
 (ref.) 233
 Amber, 351
 Ammonia, in air, 45; from coke
 plants, 104; Haber's synthesis,
 57; liquefied, (ref.) 60; in refrig-
 erating plants, 53, (ref.) 111
- Ammonium picrate powders, 405
 Ammonium sulphate, 105
 Analysis, charcoal, 130; coal, 122;
 coke, 131; fuels, 114; lubricating
 greases, 185; peat, 117; tur-
 pentine, 346; wood, 115; wood
 tar, 98
 Anthracite coal, 121
 Anti-friction alloys, 232
 Apron conveyors, 11
 Argon, 38
 Artificial resin, 350
 Artificial rubber, 373, 374
 Artificial silk, 393-395
 Asbestene, 333
 Ash, coal, 125; wood, 116
 Asphalt, 325; analyses of, 327;
 from California petroleum, 175;
 consistency of, 326; native, 324;
 oil, 324; (ref.) 329
 Asphaltic base petroleum, 167
 Asphaltum, 326
 Asphaltum enamel, 354; varnish,
 353

B

- Babbit metal, 232
 Bagasse, calorific power, 133
 Bakelite, 352, 363-365, 377; (ref.)
 379; dielectric value, 377
 Balata, 375
 Ball mill, 13
 Barytes, 333
 Bearing metals, 232
 Beaters, pulp, 387

- Beehive coke oven, 101; (ref.) 110-112
- Bell metal, 231
- Benzene, 107, (ref.) 110-112, 347
- Bessemer process, 214; acid steel, 214; basic steel, 217
- Binders for briquettes, 132
- Bitumen, 326
- Bituminous coal, 121
- Bituminous paint materials, 353
- Blast furnace, 192-194; chemical reactions in, 196-198; gases, 199; slag, 200, 201, 203, (ref.) 165
- Blau gas, 146
- Bleaching powder, 386; electrolytic, 387
- Blister steel, 212
- Blower, fan, 5-6; steam jet, 5
- Boiler compounds, 70, (ref.) 78
- Boiler corrosion, 74, 80
- Boiler water, analysis of, 74, 75; scale formation, 65-67; standards of purity, 74; summary of difficulties, 73
- Boiling test for cement, 281
- Bone black, 338
- Brass, 231
- Brick, building, 257, 261; burning, of, 260; drying of, 260; fire, 262, (ref.) 271; method of manufacture, 258; paving, 263, (ref.) 271; sand lime, 304, (ref.) 311, 312
- Briquetted fuel, 132
- British thermal units, 82
- Bronze, 231
- Bucket elevators, 11
- Burners for oil, 139
- Burning of brick, 260
- By-product coke oven, 101; chart showing increase, 108, (ref.) 110-112
- By-products of charcoal burning, 96, 97
- ### C
- Calcium carbide, 156
- Calcium cyanamide, 58
- Calcium nitrate, 56
- Calcium sulphate, effect on cement, 287; solubility of, 65
- California petroleum, products from, 174-175
- Calorific intensity, 85
- Calorific power, of bagasse, 133; of coal, formulas, 123-124; determination of, 84, (ref.) 110-112
- Calorimeters, 84, (ref.) 110-112
- Camp sanitation, (ref.) 79
- Camphor, 390, (ref.) 397
- Caoutchouc, 370
- Caps, fuse, 400; percussion, 413
- Carbenes, 327
- Carbides, 155
- Carbodynamite, 410
- Carbolineum, 318
- Carbon, in Bessemer steel, 216; in blister steel, 212; in crucible steel, 214; in iron, 207, 227; in open hearth steel, 216; rôle in combustion, 86
- Carbonate iron ores, 191
- Carbon black, 147, 338
- Carbon dioxide, in air, 40; in halls, 41; solubility of salts in water containing, 67; uses of, 41
- Carbon monoxide, effects in air, 44; formation in combustion, 91, (ref.) 60
- Carrying conveyors, 11
- Case hardening, 212

- Casein paints, 361
 Cast iron, 192, 205, (ref.) 203-204
 Castings, chilled, 207
 Castor oil, 182
 Celluloid, 391, (ref.) 397
 Cellulose, 380, (ref.) 397-398
 Cement, boiling test for, 281; classification of, 273; magnesia, (ref.) 312; manufacture of, 278; natural, 288-289; properties of Portland, 280-288; puzzolan, 295-297, (ref.) 310-312; specifications for, 290-294
 Cement paint, 359
 Cementation, process for steel, 211; index of, 284
 Cementite, 227
 Centrifugal separation, 32, (ref.) 37
 Charcoal, analyses of, 130; burning in Swedish oven, 94; by-products, 96; retort, 95, (ref.) 203
 Charcoal iron, 202
 Chatterton's compound, 378
 Chemical constituents of cement, 286-288
 Chemical wood pulp, 384
 Chilled castings, 207
 Chimney draft, 7
 China clay, 333, 388
 China ware, 269-270
 Chinese wood oil, 342, (ref.) 364
 Chlorate explosives, 404
 Chrome steel, 229
 Chrome yellow, 337
 Clay, china, 388; classification, Orton's shorter, 237-238; Orton's complete, 238-249; colloidal matter of, 249; drying of, (ref.) 271; fire, 262; organic matter in, 256; origin of, 236; properties of, 248-255; products, 235, (ref.) 271, 397; rational analysis of, 348
 Coal, 119; analyses of, 122; anthracite, 121; bituminous, 121; classification, 120; distillation of, 99; Pocahontas, 121; powdered, (ref.) 135; production of, 126; proximate analysis of, 120; purchase of, 125; weathering, (ref.) 135.
 Coal ash, 125
 Coal dust explosions, (ref.) 420
 Coal gas, 148
 Coal tar, 100; constituents of, 105; for paving, 328, (ref.) 110-112
 Coatings for iron, 357
 Coefficient of friction, 176
 Cohesive strength of clay, 249
 Coke, ammonia from plants, 104, (ref.) 111; analyses of, 131; Beehive oven, 101; by-products, 101; Otto Hoffman oven, 101; Semet Solvay oven, 101, 103
 Cold shortness of iron, 210
 Cold water paints, 260
 Collodion, 389
 Colloids, 371, 380; in clay, 249
 Column still, 28
 Combustion, 81; efficiency of, 88; elements of, 86; heat of, 82, (ref.) 110-112; spontaneous, 92, (ref.) 110; table of data, 87, (ref.) 109-112
 Compressor, air, 5, 6
 Concrete, disintegration of, 79, 311-312; water proofing of, 359
 Condensation, 28, 37
 Cones, Seger, 83, 261
 Consistency of asphalt, 326
 "Constants" of oils, 339
 Constitution of cement, 283

Converter, Bessemer, 214
 Conveyors, 3, 11, 37
 Copal, 351
 Copper sulphate, 315
 Copper, as a disinfectant, (ref.) 78
 Cordite, 414
 Corrosion of iron, causes, 71, 355;
 in boilers, 65, (ref.) 79-80; reme-
 dies for, 72, 356
 Cottonseed oil, 181
 "Cracking" of petroleum, 146
 Creo-resinate process, 318
 Creosote, coal tar, 316, (ref.) 329-
 330; composition of, 105-107
 Crucible steel, 213
 Crusher, jaw, 13; gyratory, 13
 Cupola, 205
 Cutback oil, 323
 Cyanides, 107

D

Dammar, 351
 Decay of wood, 314
 Degrees of hardness of water, 70
 Delta metal, 232
 Denaturing of alcohol, 162
 Destructive distillation, 92; of
 coal, 99, (ref.) 110-112
 Detonation, 400, 409
 Diatomaceous earth, 333, 409
 Dielectric strength, 366; of Bake-
 lite, 377
 Diffusion of gases, 371
 Diluents of coal gas, 148
 Disinfection of sewage, (ref.) 78,
 79; with copper, (ref.) 78
 Disintegrators, 16
 Disruptive effect of explosives, 416
 Distillation, destructive, 92; frac-
 tional, 28, (ref.) 37; gases from
 destructive, 147; resinous woods,
 99; wood, 93

Distilling apparatus, 28
 Draft, chimney, 7
 Drain tile, 266
 Driers, paint, 348; Japan, 349;
 oil, 349
 Drying apparatus, 35, (ref.) 37;
 rotary, 36
 Drying, air for, 50, (ref.) 60; of
 clay, (ref.) 271; of moulded
 bricks, 260; oils, 339, 348
 Dry pans, 17
 Dust, dangers of, 46
 Dust preventives, 313
 Dutch process white lead, 334
 Dynamite, 409, 411, (ref.) 420

E

Earth, diatomaceous, 333
 Earthenware, 268
 Ebonite, 373
 Eductors, 9
 Effective strength of explosives,
 (ref.) 420
 "Eggs," acid, 9
 Electrical insulation, 366-367
 Electrolysis, 71, (ref.) 364
 Electrolytic action, cause of cor-
 rosion, 71
 Electrolytic bleach, 387
 Elevators, bucket, 11
 Empty cell impregnation, 318
 Enamel, asphaltum, 354; tar, 354
 Energy of explosives, 416
 Evaporators, 23, (ref.) 37; Kest-
 ner, 27; Ordway, 25; vacuum,
 97; Yaryan, 25; Zaremba, 27
 Excess air, in combustion, (table)
 88
 Explosion, 399; of coal dust, (ref.)
 420; gaseous mixtures, 159
 Explosives, chlorate, 404; classifi-
 cation of materials, 401; disrupt-

tive effect of, 416; energy of, 416; fulminate, 412; in mining, 417, (ref.) 420; nitrate, 401; permissible, 418, 421; picric acid, 405; propulsive effect of, 416; Sprengel, 412
Explosive gelatin, 415
Extraction apparatus, 33

F

Fan blower, 5, 6
Fatty oils, 178
Ferro silicon, 203
Filter press, 31
Filtration, air, (ref.) 60
Fineness of cement, 280
Fire brick, (ref.) 271
Fire clay, 262
Fire resisting paint, 362
Fish oil, 344, (ref.) 364, 365
Flue gas analysis, 89
Fluid residue, 323
Fluxes, for smelting, 192
Foaming of boiler waters, 65, 72
Formulas, combustion, 89
Foundry iron, 202
Fourdrinier machine, 388
Fuels, analyses of, 116; briquetted, 132; classification, 113, (ref.) 134-136; relative values and costs, 163; sawdust, 133; tar, 142
Fuel oil (see Petroleum)
Full cell impregnation, 318
Fuller mills, 16
Fulminate explosives, 412
Furnace, blast, 192-194; puddling, 208; regenerative, 21-23
Fuses, 400, (ref.) 420
Fusibility of clay, 252
Fractional distillation, 28, (ref.) 37

Friction machines, 176
Fulminate, mercury, 413

G

Gangue, 191
Gas, air, 162; blast furnace, 199, (ref.) 165; Blau, 146; coal, 148; from destructive distillation, 147; diffusion, 371; engine, 159; explosive mixtures, 159; flue, 89-90; fuels, 142-144; illuminating, 149; Pintsch, 146; producer, 151-152; suction, 154; water, 149, (ref.) 60; wood, (ref.) 164
Gasoline, distillation test for, 160
Gayley dry blast, 53, 199-200, (ref.) 204
Gelatin, explosive, 415
German silver, 233
Gilsonite, 325
Glass insulators, 370
Glazes, 268; majolica, 368
Glycerides, 179
Grahamite, 325
Granite, reconstructed, 369
Graphite, 183, (ref.) 186
Greases, lubricating, 183
Griffin mills, 16
Grinding apparatus, 13
Ground water, 63
Guayule rubber, 374, (ref.) 379
Gum, resins, 350; Kauri, 351
Gum turpentine, 345
Guncotton, 406
Gunpowder, 401, 403
Gutta-percha, 374
Gypsum, 297, 307, (ref.) 311, 312
Gyratory crusher, 13

H

Hardening of cement, 280
Hardness of asphalt, 325

Hardness of water, 68
 Hard rubber, 373
 Harveyized steel, 212
 Heat of combustion, 82, (ref.) 110-112; in Bessemer process, 216-218
 Heat losses, 90; formula for computing, 91
 Heating stoves, 194-195
 Hematite ore, 189-190
 Humidity, 41-42; chart, 43
 Humus substances, (ref.) 78
 Hydrated lime, 300
 Hydrator, Kritzer, 300-301
 Hydraulic cement, 274
 Hydraulic gypsum, 308
 Hydraulic lime, 294
 Hydraulic main, 103
 Hydraulic press, 33
 Hydrocellulose, 382
 Hydrogen, 57, (ref.) 60, 86-87
 Hydrogen sulphide in air, 45
 Hydrolysis of salts in boiler water, 71
 Hygrometric chart, 43
 Hypochlorite treatment of water, (ref.) 79-80

I

Illuminating gas, 148-149
 Imhoff sewage tank, (ref.) 78
 Indeterminates, 356
 Index of cementation, 284
 India rubber, 370
 Industrial uses of lime, 302
 Inhibitors, 356
 Injector, 7
 Insulation, electrical, 366; glass, 370; high temperature, 368, (ref.) 378, 379
 Intensity, calorific, 85

Iodine number, 340
 Iron, basic, 203; Bessemer, 202; cast, 205; charcoal, 202; cold shortness of, 210; corrosion of, 72, 355; foundry, 202; malleable, 210; manufacture of, 189; paints for, 354; passivity, 356; pickling of, 356; red shortness of, 210; wrought, 208
 Irrigation water, 76

J

Japan driers, 349
 Jaw crusher, 13

K

Kalsomine, 361
 Kaolin, 253
 Kauri gum, 351
 Keisermann researches on cement, 285
 Kestner evaporator, 27
 Kindling temperature, 81-82
 Kritzer hydrator, 300-301

L

Lacquers, pyroxylin, 390
 Lampblack, 338
 Lard oil, 180
 Latex, 370
 Lava, 369
 Lead, for acid tanks, 233; sublimed, 335; white, 334
 Le Chatelier's researches on cement, 283
 Lignin, 93
 Lignites, 121
 Lignocellulose, 381-382
 Lime, calcination, 298; hydration of, 300; hydraulic, 294; indus-

- trial uses of, 302, (ref.) 311-312;
in water softening, 68-69
- Limonite, 189
- Linde process, 39-40
- Linoxyn, 348, 358
- Linseed oil, 341; (ref.) 363-365
- Liquefaction, of air, 39; of ammonia, (ref.) 60; of natural gas, (ref.) 166
- Liquid fuels, 137
- Lithopone, 336
- Lubricants, greases, 183, 185; graphite, 183, 185; oils, 177-182, (ref.) 186-188
- Lubrication, 175
- M
- Mackintosh cloth, 390
- Magnesia cement, (ref.) 312
- Magnesite, 190
- Majolica glaze, 368
- Malleable iron, 210
- Manganese steel, 229, 231, (ref.) 203, 204
- Manganin, 233
- Mastic, 357
- Mechanical analysis of clay, 252
- Mechanical pulp, 383
- Medicinal water, 63
- Mercerization, 391
- Mercuric chloride, 315; fulminate, 413
- Metal, babbitt, 232; bell, 231; bearing, 232; delta, 232; Muntz, 231; type, 233
- Metallic paint, 332
- Methane in air, 45
- Methyl alcohol, 97
- Mica, 375
- Michaelis' researches on cement, 285
- Mill, ball, 13; Fuller, 16; Griffin, 16; pug, 258; stamp, 13; stone, 17
- Mine air, 46
- Mineral black, 338
- Mineral oils, 177; sperm, 180
- Mineral water, 63
- Mining, explosives in, 417, 418
- Mixers, 19
- Molybdenum steel, 230
- Montejus, 9
- Mortar, 273
- Mortar colors, 332
- Moulding sand, 207
- Muntz metal, 231
- N
- Native asphalt, 324
- Natural cement, 288, 289
- Natural gas, 144; composition of, 145; liquefaction of, 146, 147, (ref.) 165
- "Natural gasoline" industry, 145
- Neatsfoot oil, 180
- Neutral oil, 347
- Newberry's researches on cement, 284
- Nickel steel, 229
- Nigrite, 378
- Nitrate explosives, 401
- Nitrides, 57
- Nitrocellulose, 389
- Nitrogen, cycle, 55; fixation, 56, (ref.) 55, 60; rôle in combustion, 86; sources, 40
- Nitroglycerin, 407, (ref.) 421
- O
- Ocher, 332
- Oil, asphalt, 324; burners for, 139; castor, 182; Chinese wood, 342; constants of, 339; cotton seed,

- 181; cut back, 323; driers, 348, 349; fatty, 178, (ref.) 363-365; fish, 344; linseed, 341, (ref.) 363-365; lubricating, 182; mineral, 177; neatsfoot, 180; neutral, 347; olive, 180; paints, 362; petroleum, 167; rapeseed, 181; shales, 142, (ref.) 155; soya bean, (ref.) 365; sperm, 180; varnishes, 350
- Olefin base petroleum, 167
- Oleo resin, 350
- Olive oil, 180
- Open hearth steel, 218-221
- Open tank treatment, 318-320
- Orange mineral, 337
- Ordway evaporator, 25
- Ore, iron, 189-191
- Organic matter in clay, 256
- Orton's classifications of clay, 237, 239-247
- Otto Hoffman coke oven, 101-103
- Oxyacetylene flame, 157
- Oxycellulose, 381
- Oxygen, combustion, 39; liquefaction, 39, 40; rôle in combustion, 86; in water, 71
- Ozokerite, 325, 378
- Ozone, (ref.) 60
- P
- Paint, for cement and concrete surfaces, 359; alligatoring of surfaces, 358; bituminous, 353; casein, 361; cold water, 360; driers, 348; fire resisting, 362; for iron, 354-356; materials, 331, (ref.) 363-365; metallic, 332; oil, 362; waterproofing, 359-360
- Pans, dry, 17
- Paper manufacture, 382, (ref.) 397-398
- Para red, 337
- Paraffin base petroleum, 167
- Paris white, 333
- Partition tiles, 266
- Passivity of iron, 356
- Paving brick clay, 263, 264
- Paving materials, 313
- Peat, analysis of, 117; fuel values, 119, (ref.) 134-136
- Percussion caps, 413
- Permanent hardness of water, 68
- Permissible explosives, 418, 420
- Petroleum, burners, 139; asphaltic base, 167; asphalt from, 175; composition of, 137; "cracking" of, 146; fields, 168; heat values, 140; industrial products from, 172; olefin base, 167; origin of, 169-171, (ref.) 187-188; paraffin base, 167
- Petrolithic road, 321
- Pewter, 233
- Phosphorus in steel, 218, 288
- Pickling of iron, 356
- Picric acid explosives, 405
- Pig iron, classification of, 202
- Pigments, 332, 334
- Pintsch gas, 146
- Pitch from coal tar, 328
- Plasters, 307; alca, 310, (ref.) 311
- Plaster of paris, 298, 308, (ref.) 310-312
- Plasticity of clay, 248
- Platinoid, 233
- Plenum system, 48
- Pocahontas coal, 121
- Polarization, 356
- Porcelain, 268, 269, 271, 378, 379
- Porosity of clay, 251
- Portland cement, constituents of, 274; manufacturing processes, 277-278; mechanical conception

- of the nature of, 285-286; physical properties, 280, 282
- Powdered coal, (ref.) 135
- Powder, ammonium picrate, 405; bleaching, 386; smokeless, 413
- Press, hydraulic, 33; filter, 31
- Pressure system of producer gas, 152
- Preventives, dust, 313
- Priming of boiler waters, 72
- Producer, gas, 151, (ref.) 165
- "Proof" gallons, 161
- Propulsive effect of explosives, 416
- Prussian blue, 337
- Puddling furnace, 208
- Pug mills, 258
- Pulp, beaters, 387; chemical, 384; mechanical, 383; wood, 376, 383
- Pumps, 9, (ref.) 37; vacuum, 5, 6
- Purification of air, 38, 48
- Puzzolan cement, 295
- Pyroligneous acid, 96-97
- Pyrometers, 83
- Pyroxylin, 389; lacquers, 390
- Q
- Quick process white lead, 335
- R
- Rain water, 62
- Rapeseed oil, 181
- Rational analysis of clay, 254
- Red lead, 337
- Red shortness of iron, 210
- "Reducing" lubricating oils, 177
- Refrigeration, 52; ammonia in, 53
- Regenerative furnaces, 21-23
- Removal of temporary hardness of water, 68
- Resinate process, creo-, 318
- Resinous wood, distillation of, 99
- Resins, 355, 388; gum, 350; oleo, 350; varnish, 350
- Retorts, charcoal, 95
- Richardson's researches on cement, 284
- Road, binders, 313, 321; oil, 323; petrolithic, 321
- Romac, 322
- Rosin, 352
- Rosin oil greases, 183, 184
- Rotary dryer, 36
- Rubber, 370, (ref.) 378-379; Guayule, (ref.) 379; hard, 373; vulcanized, 372
- Rubber substitutes, 373
- S
- Salts, hydrolysis of, 71
- Saponification number, 340
- Sand for foundry use, 207
- Sand lime brick, 304, (ref.) 311-312
- Sanitation, camp, (ref.) 79 (see Ventilation, Water).
- Sawdust, alcohol from, 395; for fuel, 133
- Scale, boiler, 65-67
- Screw conveyors, 11
- Segor cones, 83, 261
- Semet Solvay coke oven, 101-103
- Separators, air, 12; centrifugal, 32
- Settling tanks, 30
- Sewage, disinfection, (ref.) 78, 79; disintegration of concrete in, (ref.) 79; Imhoff tank, (ref.) 78
- Sewer pipe, 266
- Shale, oil, 142, (ref.) 165
- Shellac, 357, (ref.) 364, 365, 378
- Shrinkage of clay, 250
- Siderite, 190

- Sienna, 332
 Silex, 333
 Silicon eisen, 203
 Silk, artificial, 389; Glanzstoff, 394; nitrocellulose, 393; viscose, 393-395
 Silver, German, 239
 Slag, blast furnace, 200-201
 Slag cement, 296, 297
 Smelting of iron ore, 191; fluxes, 192
 Smoke, 91, 92, (ref.) 60, 110-112
 Smokeless powder, 413, (ref.) 421
 Soda ash, 69-70
 Soda process in paper manufacture, 385
 Soil, alkali in, 76
 Solder, 233
 Solid particles in air, 45
 Solubility of acetylene, 158; of salts in water containing carbon dioxide, 67
 Solvents, for cellulose, 381; for pyroxylin, 389; for rubber, 371
 Soya bean oil, 343, (ref.) 365
 Specific gravity, of asphalt, 325; of cement, 282; of clay, 251
 Specific heat of flue gas constituents, (table) 90
 Specifications for cement, 289
 Spent tan, 134
 Sperm oil, 180
 Spirit varnishes, 350
 Spontaneous combustion, 92, (ref.) 110
 Stamp mills, 13
 Standard specifications for cement, 289
 Starch, (ref.) 397
 Steam jet blower, 5
 Steel, 211; acid Bessemer, 214; basic Bessemer, 217; blister, 212; cementation, 211; chrome, 229; crucible, 213; Harveyized, 212; high speed, (ref.) 233-234; manganese, 230; molybdenum, 230; nickel, 229; open hearth, 218-223, (ref.) 203-204; tungsten, 230; vanadium, 230
 Still, column, 28
 Stimulators of corrosion, 356
 Stone mills, 17
 Stoneware, 266
 Stoves, heating, 194, 195
 Stucco, 307
 Sublimed lead, 335
 Sucrates, 322
 Suction gas, 152-155
 Sulphite liquor, (ref.) 78, 397; alcohol from, 385
 Sulphite process of paper manufacturing, 384-385
 Sulphur, in air, 45; monochloride, 372; in steel, 223, 228
 Surface water, 62-63
 Swedish charcoal oven, 94
 Sylvester process, 360
 Synthesis of ammonia, 57
 Syphon, 8
- T
- Table waters, 63
 Talc, 369, 388
 Tallow greases, 183
 Tar, acids, 317; benzene from coal, 107; coal, 105; creosote from, 316; enamel, 354; for fuel, 142; for paving, 328; pitch from, 328; wood, 98, (ref.) 110-112
 "Teeming" of crucible steel, 213
 Temper carbon, 207
 Temperature, of combustion, 82; measurement, 83; method for calculation, 85

Tempering of clay, 258
 Temporary hardness of water, 68
 Tensile strength of cement, 281;
 of iron, 228
 Terra alba, 333
 Terra cotta, 265
 Thermal units, British, 82
 Thermite, 113
 Thermo-chemical reactions in gas
 producers, 152
 Thilmany process, 315
 Tiles, drain, 266; partition, 266
 Tube mill, 13
 Tufa, in puzzolan cement, 295, 296
 Tungsten steel, 230
 Turpentine, 345; analyses of, 346;
 gum, 345; substitutes, 347, (ref.)
 363-365; wood, 345
 Type metal, 233

U

Umber, 332

V

Vacuum evaporators, 23, 97
 Vacuum pumps, 5, 6
 Vanadium steel, 230
 Vaporization of liquids, 158
 Varnishes, 362; asphaltum, 353;
 oil, 350; spirit, 350
 Varnish resins, 350
 Venetian red, 333
 Ventilation, 38, 46, 47
 Viscoid, 392
 Viscose, 392
 Viscosity, 182, (ref.) 186-188
 Vitreous ware, 368
 Volatility of asphalt, 326
 Vulcanized fibre, 376; linseed oil,
 373; rubber, 372

W

Washer, gas, (ref.) 165
 Water, 61-62; acidity of, 71; an-
 alyses of, 74, 75; degrees of
 hardness of, 70; filtration, (ref.)
 79; foaming of boiler, 72; for
 irrigation, 76; medicinal, 63;
 purification, 65; softening, 78-
 79; standards, 74; sterilization,
 (ref.) 79; tables, 63
 Water-proofing, of concrete, 359;
 paints, 359-360; pyroxylin com-
 positions, 390
 Water vapor (see Humidity)
 Weathering, of clay, 248; of coal,
 (ref.) 135
 Welsbach mantle, 149
 White lead, 334
 White-wash, 360
 Whiting, 333
 Wood, 115; ashes, 116; blocks,
 chemically treated, 314; decay
 of, 314; distillation, 93, (ref.)
 110-112; gas, (ref.) 164; pulp,
 376, 383, 385; preservatives,
 315; tar, 98; turpentine, 345
 Wood oil, Chinese, 342
 Wood preservatives, 318, (ref.)
 329-330
 Wrought iron, 208

Y

Yaryan evaporator, 25

Z

Zaremba evaporator, 27
 Zinc in boilers, (ref.) 78
 Zinc chloride, 316
 Zinc oxide as pigment, 334

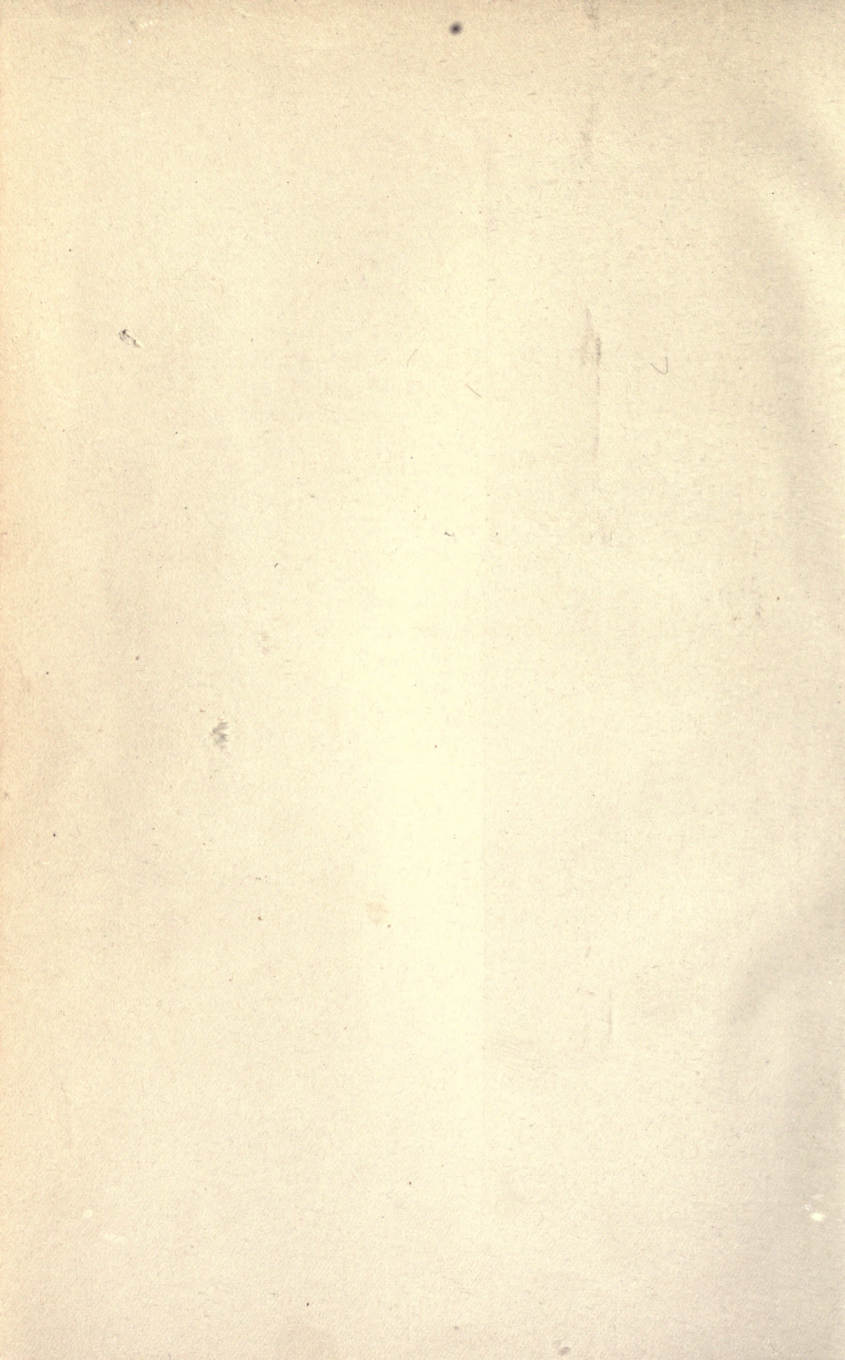

THE following pages contain advertisements of a few of the Macmillan books on kindred subjects.

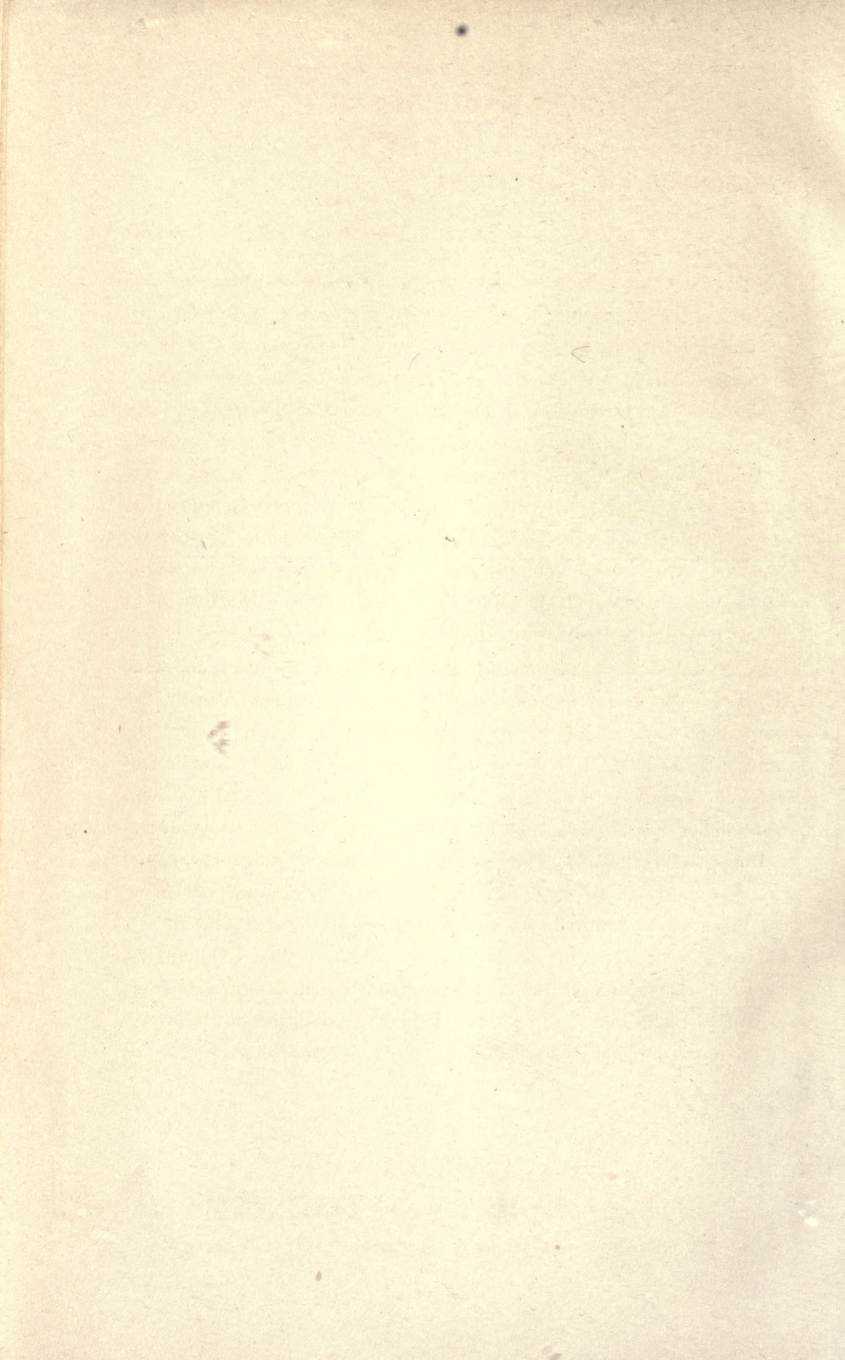

LOUIS KAHLENBERG'S

Outlines of Chemistry

Illustrated, Cloth, 8vo, \$2.60 net

A text-book for college students by the Professor of Chemistry and Director of the Course in Chemistry in the University of Wisconsin.

"The first five chapters are mainly devoted to experimental work on hydrogen, oxygen, and chlorine as a foundation of fundamental facts and laws for the sixth chapter in which the atomic and molecular theories are presented. After two chapters devoted to ozone, hydrogen peroxide, allotropy, and the halogens, in Chapter IX, acids, bases, and salts, hydrolysis, mass action, and chemical equilibrium are concisely defined on the basis of facts. Chapter XVII includes the elements of thermochemistry; Chapter XX, classification of the elements and the periodic system, and Chapter XXIV, solutions, electrolysis, and electrochemical theories. In this arrangement of the essential parts of chemical theory, and with this mode of treatment, it would seem that the author has kept well within the limits of what the average college student can readily comprehend and assimilate. As stated in the preface, the student becomes a clear logical thinker and he does not look upon the atomic and molecular theories as something arbitrary, metaphysical, and well-nigh incomprehensible; it is also mentioned that in principle this is the method of Bunsen and of many other successful teachers of chemistry. Historical connections are kept sufficiently in view by frequent allusions. The cuts are clear and well made and the subject-matter well printed. . . . A critical examination of this work gives the impression, I think, that the author has accomplished his purpose and that he has given us one of the best books and in some respects the best book that has been prepared on this subject."—*Journal of the American Chemical Society.*

PUBLISHED BY

THE MACMILLAN COMPANY

Publishers 64-66 Fifth Avenue New York

Introduction to General Chemistry

BY JOHN TAPPAN STODDARD, PH.D.
Professor of Chemistry in Smith College

Cloth, 12mo, 432 pp., \$1.60 net

A text-book on general Chemistry which presents the essential material with from one-half to three-fifths the number of words used by other texts now in use is one that will be likely to challenge attention for this if for no other reason.

Brevity by itself without adequacy would of course be a questionable recommendation. But that Professor Stoddard has not in his condensation sacrificed anything that is essential will be apparent, we believe, on a careful examination of the book. It is believed to be adequate to serve a double purpose. In the first place it provides a foundation broad enough and thorough enough to serve as an introduction to advanced study. Indeed it is felt by many experienced teachers that the plan of taking a synoptic survey of the whole field first, reserving the more minute cultivation of the separate sections for later work, is the most fruitful method in the end. It gives the student a more correct perspective of the whole subject and places him in a better position to appreciate the interrelations of its several parts; and such a plan is admirably served by a text of the proportions of Professor Stoddard's. In the second place the book is sufficient to give to students who do not study the subject for more than one year a thoroughly adequate idea of the science as a whole—its methods and its results. It is believed that a student who grasps clearly the most fundamental facts and most striking generalizations of the subject derives greater benefit from his study than one who, by considering a greater array of facts or of theories, loses himself in the complexities of the subject. The smaller compass of Professor Stoddard's book and its emphasis on essentials will commend it to teachers who wish to make sure, first of all, that their students grasp the main facts and cardinal principles of their subject.

In the use of illustrative material due attention has been paid to the practical application of chemistry in everyday life and the industries. This, indeed, is one of the features of the book and is more or less implied in the mode of presentation adopted—the mode of proceeding from the familiar to the unfamiliar.

PUBLISHED BY

THE MACMILLAN COMPANY

Publishers 64-66 Fifth Avenue New York

Applied Electrochemistry

BY M. DEKAY THOMPSON, PH.D.

Assistant Professor of Electrochemistry in the Massachusetts Institute of Technology

Cloth, 8vo, 329 pp., index; \$2.10 net

PREFACE

The following book was written to supply a need felt by the author in giving a course of lectures on Applied Electrochemistry in the Massachusetts Institute of Technology. There has been no work in English covering this whole field, and students had either to rely on notes or refer to the sources from which this book is compiled. Neither of these methods of study is satisfactory, for notes cannot be well taken in a subject where illustrations are as important as they are here; and in going to the original sources too much time is required to sift out the essential part. It is believed that, by collecting in a single volume the material that would be comprised in a course aiming to give an account of the most important electrochemical industries, as well as the principal applications of electrochemistry in the laboratory, it will be possible to teach the subject much more satisfactorily.

The plan adopted in this book has been to discuss each subject from the theoretical and from the technical point of view separately. In the theoretical part a knowledge of theoretical chemistry is assumed.

Full references to the original sources have been made, so that every statement can be easily verified. It is thought that this will make this volume useful also as a reference book.

An appendix has been added, containing the more important constants that are needed in electrochemical calculations.

PUBLISHED BY

THE MACMILLAN COMPANY

Publishers 64-66 Fifth Avenue New York

Methods of Organic Analysis

BY HENRY C. SHERMAN, PH.D.

Professor of Food Chemistry in Columbia University, Author of "Chemistry of Food and Nutrition"

Second Edition Rewritten and Enlarged

Illustrated, Cloth, 8vo, \$2.40 net

PREFACE TO SECOND EDITION

In rewriting this work after six years of constant use in the classroom and laboratory, the author has endeavored to keep in mind the needs both of students and of practising chemists. Methods which are commonly used as exercises for beginners (such, for example, as the determination of alcohol by the distillation method) are fully described with detailed explanatory and precautionary notes, while those methods which are apt to be used only by advanced students or professional chemists are given more concisely. At the end of each chapter will be found, first a list of reference books arranged alphabetically by authors, and then a chronological list of journal articles, bulletins, etc., particularly of the last few years. The abbreviations are those used by the American Chemical Society in the publication of *Chemical Abstracts*.

The scope of the work has been somewhat extended, the new matter including a chapter on solid and liquid fuels, and sections on industrial alcohol, drying oils, crude petroleum, the new international methods of glycerin analysis, and quantitative methods for the testing of enzymes. The discussions of aldehydes, sugars, proteins, and food preservatives are also much fuller than in the first edition.

These additions, and the rewriting of the original text to embody recent advances and certain changes of arrangement which have been found advantageous from the standpoint of teaching, make the present edition practically a new work.

The text and references are designed to cover, along with the directions for laboratory work, so much at least of the technology of the various topics considered as is involved in a proper appreciation of the purposes of the analysis and the significance of the analytical results.

PUBLISHED BY

THE MACMILLAN COMPANY

Publishers 64-66 Fifth Avenue New York

THIS BOOK IS DUE ON THE LAST DATE
STAMPED BELOW

AN INITIAL FINE OF 25 CENTS

WILL BE ASSESSED FOR FAILURE TO RETURN
THIS BOOK ON THE DATE DUE. THE PENALTY
WILL INCREASE TO 50 CENTS ON THE FOURTH
DAY AND TO \$1.00 ON THE SEVENTH DAY
OVERDUE.

MAY 17 1940

FEB 23 1944

MAR 15 1941
MAR 24 1941

MAR 24 1941

APR 21 1941

MAY 9 1941

OCT 7 1941 A

APR 1 1942
OCT 13 1941

APR 1 1942

MAY 14 1943

SEP 11 1943

YB 53506

Ken

LIBRARY USE
RETURN TO DESK FROM WHICH BORROWED

LOAN DEPT.

THIS BOOK IS DUE BEFORE CLOSING TIME
ON LAST DATE STAMPED BELOW

LIBRARY USE

JAN 2 1968

RECEIVED

JAN 2 '68 -11 AM

RY

LD 62A-50m-7,'65
(F5756s10)9412A

General Library
University of California
Berkeley

