

UNIV. OF
TORONTO
LIBRARY



BINDING LIST MAR 1 1923



Digitized by the Internet Archive
in 2008 with funding from
Microsoft Corporation

Paul
I
Industrial Education Magazine

MANUAL TRAINING MAGAZINE

EDITORS

CHARLES A. BENNETT
WILLIAM T. BAWDEN

ASSISTED BY

WILLIAM E. ROBERTS
ARTHUR D. DEAN
FRANK M. LEAVITT

VOLUME XXXIII
1921 - 1922

Published Monthly by
THE MANUAL ARTS PRESS
PEORIA, ILL.

179183
4/4/23

INDEX

Names of contributors of articles are set in small capitals.

- ABERG, CHARLES—Sheet-Metal Work for Junior High Schools, 229
- Alfonso Iannelli, The Work of—CHARLES A. BENNETT, 312
- Art In Labor—HENRY W. KENT, 295
- ASHLEY, LAWRENCE F.—Manual Arts in Illinois, 1
- Automobile Show, An—LESTER C. SMITH, 160
- BACKUS, ALLEN D.—The Project Problem, 143
- BAKER, J. N.—The Selection of Projects for a Mechanic Arts Course, 77
- BEESON, MARTHA—Teaching the Elements of the Process of Paper-Making, 8
- BENEDICT, W. LE ROY—The Project Record, 349
- BENNETT, CHAS. A.—Alfonso Iannelli, The Work of, 312; Eastern Arts Convention, The, 386; Flemish Wood Carving, Suggestions from Old, 303; Milwaukee Convention, A Cross Section of the, 275; Okmulgee High School, The, 265; Planning a school to fit exceptional conditions, 192; Vocational Education Program at the Meeting of the Department of Superintendence, 351
- BREWER, JOHN M.—Practical Arts for Vocational Guidance in the Junior High School, 69
- BURLING, BEVERLY B.—Selection and Training of Instructors for Vocational Schools and Shops, 261
- Candle Making—An Industrial Arts Problem for the Elementary School—L. A. HERR, 41
- CHENEY, FRANK W.—The Boy's Course or the Teacher's Course?, 183
- Current Publications—34, 68, 105, 142, 182, 220, 260, 294, 334, 372, 405, 440
- DANK, MICHAEL C.—Toy-Making for Handicapped Children, 198
- Designing Bird Houses for Particular Occupants—EMANUEL E. ERICSON, 343
- DOOLEY, W. H.—New York City Textile High School, 407
- DRUCKER, MAX—Supervision of Mechanic Arts, 346
- Eastern Arts Convention—CHARLES A. BENNETT, 386
- Economic Civics—FRANK M. LEAVITT, 373
- EDGERTON, A. H.—The Present Status of Industrial Arts Education in our Elementary Schools, 335, 377, 413
- Editorial Review For the Month: Americanization, 86; American Metalwork of the Eighteenth Century, 124; Another Point of View, 427; Armistice Day, 202; Art Craftsmanship, Training in, 316; Boy Problem, The, 16; John Callahan Becomes State Superintendent in Wisconsin, 18; Continuation School, The, 427; Craftsmen Needed, More Expert, 320; Arthur Dean Accepts Appointment in Veteran's Bureau, 123; Delgado Trade School in New Orleans, The, 204; Disarmament Problems in the Schools, 205; George W. Eggers goes to Denver, 164; E. E. Ericson Joins the staff of This Magazine, 53; Royal Bailey Farnum Goes to Massachusetts, 52; Household Mechanics Course, The, 54; Illinois Drops Behind, 87; Intensive Plan for Newark Reaches Cincinnati, The, 18; Professor Jacobs Goes to Santa Barbara, 124; Mr. Lampkin Resigns, 54; Manual Arts Conference, The, 242; Manual Training Shop Not a Play Room, 393; Professor McDonald Goes to the University of Ohio, 428; Mechanical Drawing, A Survey of, 122; Monographs on Vocational Education, A New Series of, 122; National Scheme of Organization of Vocational Teachers and Supervisors, A, 356; New Correspondent in the East, A, 53; New Development in Detroit, 278; New Representative in the Southwest, A, 128; New Supervisor in Minnesota, A, 393; Project Problem, The, 390; School Factory in Des Moines, A Unique, 50; Shop Recitation Period, A, 206; William Hawley Smith, Death of, 426; Smith-Hughes Classes, The Personnel of, 362; Summer Manufacturing in Cincinnati, 203; Thomas Charles, 124; Too Much of a Good Thing, 16; Toy Designing, 161; Professor Vaughn Becomes President of Harding College, 51; Vocational Education Association of the Middle West, The Origin of the, 357; Vocational Guidance Convention, The, 361; Vocational Teacher Training in California, 392; Western Arts Association, New President of the, 88; West Virginia University, New Course Started at, 163; Charles H. Winslow Goes to Philadelphia, 52; Woman's Institute of Domestic Arts and Sciences, Scranton, Pa., The, 161
- Effect of Overcrowding upon Initiative in the School Shop, The—WILLIAM F. VROOM, 35
- ERICSON, EMANUEL E.—Designing Bird Houses for Particular Occupants, 343; National Society Convention, Outstanding Features of, 272; School Shop Accidents and Their Prevention, 223; Western Arts Association, The, 422
- Flemish Woodcarving, Suggestions From Old—CHARLES A. BENNETT, 303
- Foremanship Training in the Lumber Industry—GEORGE HENRY JENSEN, 186
- GUENTHER, FLORENCE M.—Correlation of Sheet-Metal Work and Art, 316
- HERR, L. A.—Candle Making—An Industrial Arts Problem for the Elementary School, 41
- HUNT, DEWITT—Shop Organization and Care of Shop Equipment, 81, 110
- Industrial Arts Education in our Elementary Schools, The Present Status of—A. H. EDGERTON, 335, 377, 413
- In Foreign Countries: Age Limit for Continuation Schools, London Lowers, 133; Art and Industry, The Alliance of, 324; Continuation Schools, Encouraging Start Made by the London, 285; Continuation Schools, Proof of the Value of German, 285; Continuation Schools in Germany, The Effect of the War on, 133; Continuation School Work in London, Exhibit of, 399; Discovery of Aptitude a First Step in Education, The, 94; Easter Conference of Manual Training Teachers, The, 26; Educating Public Taste, 325; English Labor Party on Education, The, 211; Fundamental Education, Importance of, 286; Handicraft Teachers, Certifica-

- tion of, 95; Handwork, The Cultural, and the Industrial Value of, 366; Industrial Education for India, Differences of Opinion Concerning, 366; Junior Technical Schools, The Aim of, 367; Manual Training and the Near East Relief, 170; Oneness of Education, The, 95; Practicability of Learning Trades in Modern Commercial Shops, Doubts the, 60; Printing School at Edinburgh, 254; Secondary and Higher Education, Viewpoints Concerning, 398; Sloyd School in Askov, Denmark, 61; Testing Color Vision, 325; Trade School in Albania, A New, 186; Use of Colored Plaster Casts, 399; Vocational Training and Tests, 254
- JENSEN, GEORGE HENRY—Foremanship Training in the Lumber Industry, 186
- KENT, HENRY W.—Art In Labor, 295
- LEAVITT, FRANK M.—Economic Civics, 373
- LEVY, FLORENCE N.—Teacher Training in New York City, 155
- LOVE, EDWIN M.—Lumber Cost Figuring for Manual Training Teachers, 116
- Lumber Cost Figuring for Manual Training Teachers—EDWIN M. LOVE, 116
- MADISON, FRANK HILTON—How a Great Museum Helps the Schools in Teaching Furniture Materials, 301
- Manual Arts in Illinois—LAWRENCE F. ASHLEY, 1
- McCLOSKEY, J. H.—The Old Way; The Present Way; A Better Way of Teaching Any Trade, 119
- Mechanic Arts, Supervision of—MAX DRUCKER 346
- MILLER, JAMES C.—Vocational Education in Ontario, 12
- Milwaukee Convention, A Cross-Section of the—CHARLES A. BENNETT, 275
- Museum Helps the Schools in Teaching Furniture Materials, How a Great—FRANK HILTON MADISON, 301
- National Society Convention, Outstanding Features of—E. E. ERICSON, 272
- Okmulgee High School, The—CHARLES A. BENNETT, 265
- The Old Way; The Present Way; A Better Way of Teaching Any Trade—J. H. McCLOSKEY, 119
- Paper Dress Form Making Taught in School—H. W. ROBERTS, 271
- Part-Time Education, Establishing a State Program of—K. G. SMITH, 107
- PERRY, W. F.—Teaching Battery Connections, 385
- Photographs From Everywhere, 353, 426
- Planning a School to Fit Exceptional Conditions—CHARLES A. BENNETT, 192
- Point of View, A—ARTHUR D. DEAN, 19, 55, 89, 127, 165, 207, 248, 281, 321, 363, 394, 430
- Process of Paper-Making, Teaching the Elements of the—MARTHA BEESON, 8
- Project Problem, The—ALLEN D. BACKUS, 143
- Project Record, The—W. LE ROY BENEDICT, 349
- Projects for a Mechanic Arts Course, The Selection of—J. N. BAKER, 77
- Projects, Problems and Notes:
Arm Rocker, Child's, 288; Automobile Practice Wiring, 287; Birthday Cake Stand, 328; Bookcase, 64; Boring Job, A, 32; Bread Cupboards, Ancient, 326; Coaster, Drawing of, 215; Cost of Lumber, Coping With the High, 218; Cost of Lumber, Formulas for Obtaining the, 28; Crate Corners, 62; Casein Glues Exceptionally Durable in Damp Places, 333; Cedar-Lined Chest, A, 31; Chair, A Beautiful Old, 328; Chair Lamp, 403; Chalk Box, A Use for the Empty, 369; Circular Shop, A, 255; Dancing See-Saw, 404; Drawing of Every Object, A, 369; Fiber Chair Seats Woven by Boys in Woodworking Classes, Anderson, Indiana, 287; Floor Lamp and Shade, 255; Folding Chairs, Making, 213; Forge Practice, Examination, 436; Forge Project, The Butcher Knife as a, 139; Gumwood Chest, 290; Hammock Hook, 292; Hurdle, 29; Industrial Arts Departments and the School Bazaar, The, 288; Indirect Lighting Fixture, An, 257; Lettering, Teaching, 134; Machine Gun, 175; Machine Shop Problems, 102; Machine Shop Work, Exhibit of, 368; Mahogany Finish, Matching, 290; Mantel-Clock, 328; Manufacturing Problem, Another, 258; Microscope in Teaching Tool Sharpening, Use of the, 28; Mirror Frame, 328; Miter-Box Table, 66; Moisture Content for Wood, A Rapid Method of Determining, 218; Old Furniture That is New, 327; Ornamental Hinges, Cheap, 437; Pantagraph, A, 400; Printing Project, A, 102; Problems from St. Louis, More, 134; Railway Bridge, 257; Rocker, Arm, 331; Rocking Duck, 437; School Visit, A, 213; Sewing Box, 368; Sixteen-foot Row-Boat, A, 30; Soldier, 172; Steel Hardening Tester Magnet, A, 96; Stone Building Blocks, 290; Table Salt Container, A Handy, 215; Toy-Making in Pittsburgh, 177; Toy Motor Truck, 177; Toys and Boys, 172; Toys Made for Sale at Rochester, 175; V-Tool Holder, 219; Why Belts are Stiff, 28; Why Lumber is Steamed During Kiln Drying, 333; Windmill and Weather Vane, Novelty, 438; Woodworking Problems From St. Louis, Elementary, 96
- ROBERTS, H. W.—Paper Dress Form Making Taught in School, 271
- Scale for Judging Manual Arts Teachers, The use of a—PAUL V. WOOLLEY, 5
- School Shop Accidents and Their Prevention—E. E. ERICSON, 223
- Selection and Training of Instructors for Vocational Schools and Shops—BEVERLY B. BURLING, 261
- Sheet-Metal Work and Art, Correlation of—FLORENCE M. GUENTHER, 316
- Sheet-Metal Work for Junior High Schools—CHARLES ABERG, 229
- Shop Organization and Care of Shop Equipment DEWITT HUNT, 81, 110
- Smith-Hughes Education, The Student Factor in FRANK C. VINCENT, 221
- SMITH K. G.—Establishing a State Program of Part-Time Education, 107
- SMITH, LESTER C.—An Automobile Show, 160
- Teacher Training in New York City—FLORENCE N. LEVY, 155
- Teaching Battery Connections—W. F. PERRY, 385
- Textile High School, New York City—W. H. DOOLEY, 407

- Toy-Making for Handicapped Children—MICHAEL C. DANK, 198
- Toys, Putting "Pep" into—HARRY E. WOOD, 151
- Trade-School Work, Conclusions Reached in—GEORGE A. WILLOUGHBY, 189
- VINCENT, FRANK C.—The Student Factor in Smith-Hughes Education, 221
- Vocational Education in Ontario—JAMES C. MILLER, 12
- Vocational Education Program at the Meeting of the Department of Superintendence—CHARLES A. BENNETT, 351
- Vocational Guidance in the Junior High School, Practical Arts for—JOHN M. BREWER, 69
- VROOM, WILLIAM F.—The Effect of Overcrowding upon Initiative in the School Shop, 35
- Washington Correspondence:
 Army Training, The Technic of, 283; Army Training Plans, 433; Budget Bureau Organizes, 59; Bureau of Education, Reorganization of the, 131; Bureau of Education Conference, 210, 323; Department of Education Petition, 211; Department-of-Education Program, The, 169; Department of Public Welfare, Education, and Labor Suggested, A, 169; Educational Development in the Army, Recent, 130; Educational Surveys Made by the United States Bureau of Education, 284; Education in the Reorganization of the Executive Department, 168; Federal Board, Changes in, 251; Federal Board Personnel, Changes in, 92; Federal Board for Vocational Education, 397; Important Changes in Personnel, 435; Legislative Complications, 23; Legislative Tangle, A, 92; Manual Training Ideals are Basic Character Ideals, 365; New Commissioner of Education, The, 26; Other Changes, 132; Proficiency Rating, 252; Public Duties of the Manual Training Teacher, 364; Reorganization, Another Step Toward, 211; Two Dinner Conferences, 210
- Western Arts Association, The—EMANUEL E. ERICSON, 422
- WILLOUGHBY, GEORGE A.—Conclusions Reached in Trade-School Work, 189
- WOOD, HARRY E.—Putting "Pep" into Toys, 151
- WOOLLEY, PAUL V.—The Use of a Scale for Judging Manual Arts Teachers, 5

MANUAL TRAINING MAGAZINE

EDITORS CHARLES A. BENNETT, Peoria, Illinois.

WILLIAM T. BAWDEN, Assistant to Commissioner of Education, Washington, D. C.

ASSOCIATE ARTHUR D. DEAN, Professor of Vocational Education, Teachers College, New York City

EDITORS FRANK M. LEAVITT Associate Superintendent Public Schools, Pittsburgh, Pa.

WILLIAM E. ROBERTS, Supervisor of Manual Training, Public Schools, Cleveland, Ohio.

Business Manager L. L. SIMPSON.

Published monthly by The Manual Arts Press, 237 N. Monroe St. Peoria, Illinois.

Subscription Price, \$1.50; Canada, \$1.80; Foreign, \$2.00. Single Copies, 25 cents; Foreign, 30 cents.

Subscriptions, remittances, and manuscripts should be sent to THE MANUAL ARTS PRESS, Peoria, Illinois.

The Manual Arts Press was incorporated July 19, 1909. The stock is owned by Charles A. Bennett, president; William T. Bawden, vice-president; A. M. Wolgamott secretary; L. L. Simpson, treasurer.

CONTENTS

MANUAL ARTS IN ILLINOIS.....	<i>Lawrence F. Ashley</i>	1
THE USE OF A SCALE FOR JUDGING MANUAL ARTS TEACHERS.....	<i>Paul V. Woolley</i>	5
TEACHING THE ELEMENTS OF THE PROCESS OF PAPER-MAKING (Illustrated).....	<i>Martha Beeson</i>	8
VOCATIONAL EDUCATION IN ONTARIO.....	<i>James C. Miller</i>	12
EDITORIAL REVIEW FOR THE MONTH.....		16
Too Much of a Good Thing—The Boy Problem—The Intensive Plan of Newark Reaches Cincinnati—John Callahan becomes State Superintendent in Wisconsin.		
A POINT OF VIEW.....	<i>Arthur Dean</i>	19
The Technical Curriculum and the High School.		
WASHINGTON CORRESPONDENCE.....	<i>William T. Bawden</i>	23
Legislative Complications—The New Commissioner of Education.		
IN FOREIGN COUNTRIES.....		26
The Easter Conference of Manual Training Teachers.		
PROJECTS, PROBLEMS AND NOTES.....		28
Use of the Microscope in Teaching Tool Sharpening—Formulas for Obtaining the Cost of Lumber—Why Belts are Stiff—Hurdle—A 16-foot Row-boat—A Cedar-lined Chest.		
CURRENT PUBLICATIONS.....		34
FIELD NOTES.....		IV
Pageant of Progress Exposition—From the North—Around New York—California Field Notes—Items from New England—Southeastern Items—From the Southwest—From Pennsylvania—Vocational Courses Given by Knights of Columbus—Work Done by Students—To Teach the Trade of Office Boy.		
TRADE NOTES.....		XXX
BOOK NOTES.....		XXXVII

This Magazine is kept for sale at McClurg's in Chicago, and Brentano's in New York.

Entered at the Post Office at Peoria as Second-Class Matter. Copyright, 1920, The Manual Arts Press.

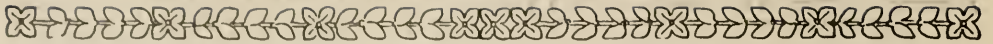

FIELD NOTES

PAGEANT OF PROGRESS EXPOSITION

WHAT is known as a Pageant of Progress Exposition is to be held at the Five-Million-Dollar Municipal Pier, Chicago, from July 30th to August 14th. It is being given under the auspices of the Chicago Boosters' Publicity Club, the Health and Sanitation Exhibition, the Chicago Association of Commerce, and the Illinois Manufacturers' Association. On this Pier are two of the world's largest exposition halls, each 2340 ft. long. The floor space in these two halls has been divided into sixteen sections allotted to the various industries. Manufacturers from all over the country are being invited to send exhibits. Each section will depict the *history and growth* of some special industry from the earliest crude methods of man to the super-human efficiency of modern machinery. The aim of the exposition is said to be 75 per cent education and 25 per cent entertainment. With this plan in view, exhibitors have been requested to send working exhibits showing how their products are made. In cases where machinery is too heavy or cumbersome to be transported to the Pier, photographic displays will be arranged picturing the evolution of the product from the raw material to the finished article.

FROM THE NORTH

THE Minnesota Legislature at its session just closed passed what appears to be an excellent evening school bill. School districts may establish and maintain public evening schools as a branch of the public schools. These schools shall be available to all over sixteen years of age who cannot attend full-time day school in the district. These evening schools will be under the direction and control of the State Board of Education.

One-half of the salaries of the teachers of the evening schools will be paid from state funds or state and federal funds combined, in so far as such funds are available. Attendance at evening schools of persons under twenty-one years shall entitle a school district to its pro rata apportionment of state school funds on the same basis as provided for day schools. Each evening session of two or more hours will count the same as one day.

It is expected that the State Board of Education in its regulations governing evening schools will approve for state funds both trade extension and trade preparatory classes, some types of home economics subjects, academic subjects of the grades and high school, and Americanization classes.

In the education bill as passed, special state aid will continue to be given to industrial departments of schools. A sharp fight was made on this provision. The act modifies the classification of public schools by recognizing junior and senior high schools. It defines the scope of each. Aid is provided for classes for the crippled, blind, deaf, sub-normal and speech defectives.

The proposals for part-time and continuation schools failed to be enacted. The bill was drafted by the Department of Education at the request of the legislature of two years ago, and so the Department could scarcely push the passage of a bill broadening its powers and activities to a great extent. There was no particular enthusiasm for these two proposals, tho it is understood the legislators from the three largest cities generally favored it. Some legislators thought they saw in these and other educational proposals too strong a trend toward socialism.

C. P. Carey, superintendent of public instruction in Wisconsin for nearly twenty years, is about to retire. His successor is John Callahan, who has occupied the position of secretary of the state board for vocational education.

—JOHN FRIESE.

AROUND NEW YORK

DR. Gustave Straubenmuller, associate superintendent of schools, New York City, at a recent conference on the need for vocational schools gave eight points which he deemed imperative for teachers, principals and vocational counselors to keep in mind at all times. They were:

- (1) That a normal education is fundamental and basic.
- (2) All should have the feeling that human material is being wasted as we are wasting natural resources.
- (3) That every boy and girl may fit comfortably into several niches, but one is more suitable than the others.
- (4) Determine the general tendencies; then study special tendency within that particular group.
- (5) All counselors should know the hygienic, economic, technical and sanitary conditions in the neighborhood in which they are working.
- (6) The proper selection of a trade is vital to the pupil, and to his community.
- (7) That the employer must do his share in educational and vocational guidance.
- (8) To remember that "job getting" is easier than vocational guidance.

Little Giant Wood Lathes

MOTOR
DRIVEN

ALSO
FURNISHED
WITH BELT
DRIVE
FROM
OVERHEAD
OR
BENEATH

GUARAN-
TEED
FOREVER
AGAINST
DEFECTIVE
MATERIAL
AND
WORK-
MANSHIP

SOLD ON
30 DAYS
TRIAL

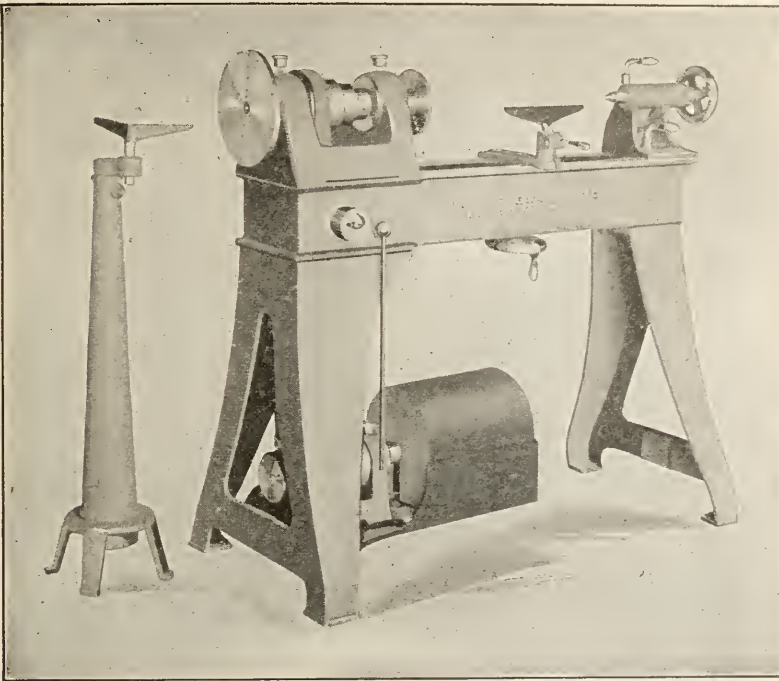

Equipped throughout with Hyatt High Duty Roller and Ball Thrust Bearings, which reduce power bill by one-half. Without attention, bearings will last almost indefinitely.

Runs smooth-
ly, without
noise or
vibration.
Years ahead of
any other
lathe made.

Complete
literature
upon
application.

Prompt
delivery now,
but orders
should be
placed
immediately
if Fall
delivery is
required.

**LITTLE GIANT
COMPANY**

220 Rock St.
Mankato,
Minn.

U. S. A.
Established
1876

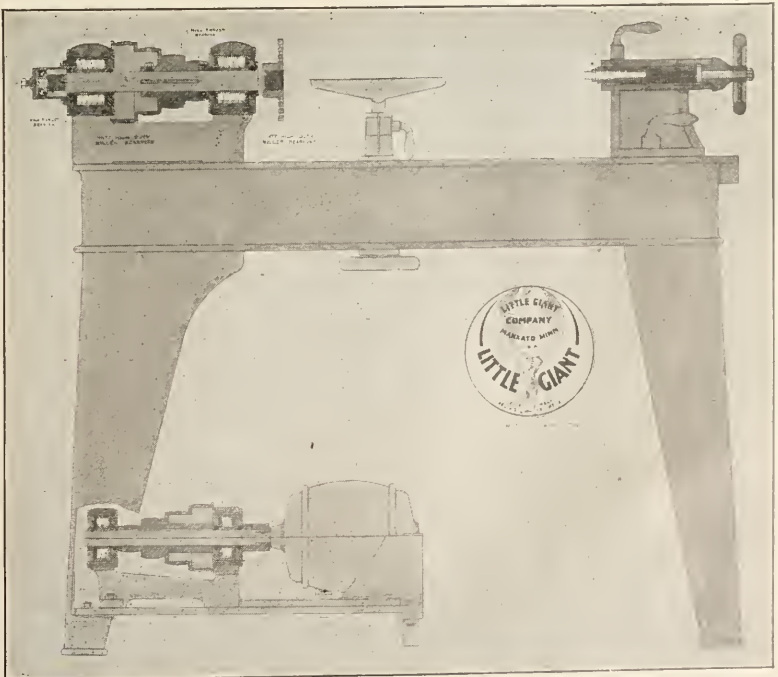



FIELD NOTES—(Continued)

In speaking of continuation schools, Dr. Straubemuller said that long ago he came to the conclusion that if properly conducted they would reach more children than could be reached by the elementary schools. The work is not being as well done now as it will be in five or ten years, but the thing to do is to get together and work and think of the subject even tho that subject is not perfect at the present time. He also commented on the intelligence tests and said that they would be far-reaching in their consequences, and that great experience could be gathered from them if they were properly conducted.

The conference was the occasion of the annual meeting of the New York City Vocational Guidance Association. Principal Louis Marks of Public School 64, Manhattan, told of the experiences in his school. It was his opinion that vocational guidance should begin at infancy, and that the work should be carefully guided, systematized and directed by one person.

Director Siegel stated that the aims of the vocational schools were to maintain the three R's, literacy, health, recreation, thrift, citizenship, counselling, and extension training.

Other speakers were Michael Lucey, principal of the Julia Richman High School; R. W. Burnham, principal of the Cooperative High School, and A. E. Kidd of the Western Electric Company. I. David Cohen acted as chairman of the conference, and announced that in all probability there would be another conference in the fall on the side of industry. "It is the hope of the association," he said, "to crystallize thought and make definite recommendations, and then be able to say that New York stands solidly behind these principles."

Examination for license as teacher of freehand drawing in high schools will be conducted by the board of examiners, at the hall of the Board of Education, Park Ave. and Fifty-ninth St., Manhattan, on Monday and Tuesday, Sept. 19 and 20, 1921, and Monday and Tuesday, March 13 and 14, 1922. There are a number of vacancies, and candidates who receive good ratings may expect early appointments to well paid and permanent positions.

The examination is given on two successive days, and those successful in passing the written and drawing (practical) tests are later examined orally in a teaching test given before a class.

The salary schedule for assistant teachers in high schools runs from \$1900 to \$3700, by annual increments of \$150. The board of examiners is empowered to award credit for outside teaching ex-

perience, and for experience in a professional occupation or in a trade in cases of appointees to teach a subject related to such occupation or trade. The credit thus given entitles a teacher to a place on the schedule as tho he had served for the period so credited. A circular giving full particulars as to conditions of eligibility, scope of examination, etc., may be had by addressing the Board of Examiners, 500 Park Ave., New York, N. Y.

A special meeting of the high school art teachers was held Thursday, May 12, in the studio of Messrs. Basing and Hewlett, 163 Clymer St., Brooklyn, N. Y. Over three-score teachers heard the discussion on color and design for pageants, which had been arranged by Mr. Hewlett and Mr. Basing, at the request of Dr. J. P. Haney, director of art in high schools.

Many forms of draperies suitable for stage backgrounds and curtains were hung around the studio, and the hosts explained to the teachers the manner in which colored patterns could be applied to these in simple fashion.

A number of special devices for lighting were also arranged for the art teachers, that they might be informed as to the different color effects to be gotten upon the school stage thru the use of small spot-lights and colored sheets of gelatine. The great value of the electrical device known as the "dimmer" was also illustrated. Mr. Hewlett gave many helpful hints in regard to different forms of stenciling and dyeing in the making of stage decorations, and Mr. Basing showed how, thru the employment of the miniature theatre, which was set up in the studio, all the effects arranged for a large stage could be planned and worked out in advance.

This meeting is one of several that have been planned to assist art teachers in the pageant work of the schools. A number of instructors are now engaged in aiding in the plans for the pageant for "America in the Making," at the next meeting which will be held in the Washington Irving High School. A special "color" program will be given. This will deal with the art side of the pageant, that is, with the color schemes, the massing of units in designs, the arrangement of backgrounds, etc. The speakers will illustrate their suggestions with groups of girls clad in pageant costumes. The meeting will be open to all teachers in both the elementary and high schools, who are interested in the subject of pageantry.

Many practical and helpful suggestions for the pageants that will be features of the "America's Making" celebration next fall were offered to teachers at the conference held at the Washington



*Proof
Reading*

Proof Reading

Permits of Association with Great Minds

PROOF READING is an essential process of good printing, for when properly done it eliminates all errors both typographical and technical.

Cold type has one distinct advantage over handwriting. Errors in print are easily discernible—no false claim that an “r” is an “s,” or that an “a” is an “o,” or that the grotesque mark in the text is a period when it looks exactly like a comma, can influence the proof reader of a printed product.

Constant association with English and its handmaidens, capitalization, punctuation, spelling, and paragraphing, cannot fail to leave its influence on the impressionable minds of the pupils who are fortunate enough to be in the school printshop.

All the service resources of this great company, including experienced educators, efficiency engineers and selling organization are at your disposal.

Write to-day, to

F. K. PHILLIPS, *Manager*, EDUCATION DEPARTMENT

AMERICAN TYPE FOUNDERS COMPANY

JERSEY CITY, NEW JERSEY

BOSTON, MASS.
NEW YORK CITY
PHILADELPHIA, PA.
BALTIMORE, MD.
RICHMOND, VA.

BUFFALO, N. Y.
PITTSBURGH, PA.
CLEVELAND, OHIO
CINCINNATI, OHIO
ATLANTA, GA.

CHICAGO, ILL.
DETROIT, MICH.
ST. LOUIS, MO.
MILWAUKEE, WIS.
MINNEAPOLIS, MINN.

KANSAS CITY, MO.
DENVER, COLO.
PORTLAND, ORE.
SAN FRANCISCO, CAL.
SPOKANE, WASH.
WINNIPEG, CANADA





FIELD NOTES—(Continued)

Irving High School. Superintendent William McAndrew led the program and described the scope and purpose of the great pageant movement. "Particular stress" said Mr. McAndrew, "should be laid upon the contribution of the more recent immigrant to America. The work of the founders of the country was well presented in the recent pageants of democracy. What is to be emphasized now is what the later courses have done in aiding to build up the country."

—W. H. DOOLEY.

CALIFORNIA FIELD NOTES

THE great interest in California during the past month has been in the series of laws pertaining to schools which have been passed by the legislature. Most of the bills have already been signed by the Governor but some of them are still in his hands; and it is firmly believed that all of the bills will ultimately be signed and become laws.

Two outstanding facts regarding these bills are sources of satisfaction in California. One is that every measure prepared or supported by the California Teachers' Association before the last session of the Legislature has passed both houses and is now in the Governor's hands. On the other hand, every measure opposed by the California Teachers' Association failed in either one or the other of the legislative bodies. Furthermore, the bills now in the hands of the Governor were either directly fathered by the California Teachers' Association or in accord with recommendation from the Council of Education, the governing body of the Association.

While no acts were passed immediately bearing upon manual training, vocational education, or any aspect of these, except a minor bill relating to part-time education, there are several bills which have important applications. One of these, which relates to the apportionment of state and county elementary funds, makes it possible now for the first time in the history of this state, for the county schools to benefit by necessary supervision in special subjects, including, therefore, manual training. This apportionment bill provides that for every certain proportion of pupils in country districts, there shall be provided a special sum of money for supervisory purposes. It will now, therefore, be possible for country schools, *even the one-room school*, to maintain manual training under expert supervision. This is a need which has long been felt all over the country, and as California is in the vanguard in this advance, our State can well be proud of its progressiveness.

Another bill of especial interest is the bill which provides for the establishment of junior colleges. The particular point of interest here, is that these colleges are intended to serve not alone as mediums of training for further college careers, but also as institutions in which vocations may be taught. Thus, for example, a boy who desires to become a surveyor may get his training in a junior college and not be obliged to get his preparation thru a correspondence course. The same is true of electricians and machinists who desire to be versed in the technical aspects of their work.

Another bill which was passed that undoubtedly has interest to the readers of this magazine, is a bill entitled the Children's Rights Bill. This bill makes it possible for local principals or superintendents to excuse a child to go to work who might otherwise be required to remain in school by reason of the compulsory school attendance law. The compulsory school law in this State requires all children to attend school up to sixteen years and go to part-time school up to eighteen.

It may be interesting to note here that our part-time education act, which it is generally believed is one of the most thoro and comprehensive acts relative to part-time education on the statute books of any of the states, was attacked by a body of night-school teachers in one of our prominent cities. The object of these teachers was to have the law changed so as to make it possible to substitute evening school work in lieu of the required attendance upon school during the working hours of the day. It is self-evident that had this vicious proposition been successful, it would have completely nullified the very benefit which part-time education is intended to provide; namely, compulsory education for all working boys and girls up to the age of eighteen, during the day. Special credit in preventing the passage of this objectionable bill is due to Dr. E. R. Snyder, our State Commissioner of Vocational Education.

Probably one of the reasons why the educational program in California has been so successfully legislated is the fact that a special hold-over committee of the Legislature of two years ago made a thoro study of the educational activities in this state and prepared a special report embodying recommendations for the improvement of our educational system. These recommendations are the result of much careful investigation and many meetings to which numerous persons interested in the educational program of the State were invited to appear and present their views.

—CHARLES L. JACOBS.

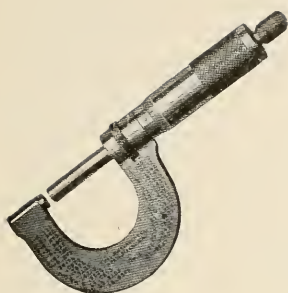

WHEN a young fellow comes to me for advice on what tools to buy, I tell him

Starrett Tools

"I've found that Starrett Tools are easiest to use. Every adjustment is made simple and positive.

"When you've got a complete kit of Starrett Tools, you feel that you're ready for any job that comes along. That's a good feeling to have. It gives you confidence.

"And keep your weather eye out for new Starrett Tools.

"If you want to keep on improving your work, you'll need to keep on improving your tool kit.

"Round out your Starrett Tool outfit—ask the hardware dealer what's new.

"The Starrett Catalog No. 22 "EF" is a book every mechanic should have around. Write for it now."

THE L. S. STARRETT COMPANY

The World's Greatest Toolmakers
Manufacturers of Hack Saws Unexcelled
ATHOL, MASS.



© 1921



Starrett Tools

42-172



FIELD NOTES—(Continued)

ITEMS FROM NEW ENGLAND

THE Vocational Education Society of Boston held its final meeting for the present season at Healy's Hotel, Boston, on Saturday, May 14th last. After lunch the annual report of the secretary was read, following which the membership committee announced the results of the membership drive which has been conducted during the year, and awarded a prize to Mr. Moriarty for his efforts in securing new members.

The following officers were then elected for the ensuing year, service to begin next October: President, George F. Hatch; vice-president, Andrew J. Leahy; treasurer, Richard Benson; secretary, Maurice J. Moriarty; librarian, Martin L. Olson.

The social and program committees were planning to provide an outing at Houghton's Pond, Blue Hills, about the middle of June—a reminder of the many enjoyable recreational trips which were so eagerly anticipated when the then Boston Manual Training Club owned a bungalow at Riverhurst, Billerica, Mass.

John C. Brodhead, assistant superintendent in Boston schools, addressed the Society on the subject "Shopwork in Grades VII, VIII and IX: Manual Training, Vocational Guidance and Industrial Education." Among the salient features of his address were the following:

In the past, education has too often meant a long and narrow path over which all must travel alike in order to receive an education, regardless of the nature of the training best suited to each individual, but conditions have been materially changed, and it is now possible for the average pupil to secure that type of education which will best develop his latent possibilities and most thoroly train him for such demands as shall be made on his ability later in life. The schools of Boston are constantly striving to vivify and broaden their curriculum in order to afford equal educational opportunities for all types of pupils. Shop activities in these schools are or should be basic and definitely related to community needs, with necessary regard for pupils' ability and the administration expense. Identity of activities, such as machine shop practice, wood-working, etc., is not so essential as is the educational value and the concreteness of the work. Fewer activities and longer try-out periods are advisable for best results.

The work in the intermediate shops should be very definite in its nature, especially in grades seven to nine, and should afford desirable opportunities for the following classes of pupils:

1. Those pupils, normal and of good progress,

who like to accompany their general education with some shopwork. For such there should be $1\frac{1}{2}$ or 2 hours' work a day.

2. Those who, for academic reasons, need the stimulus of active or strenuous work, such as our prevocational pupils. Authentic tests have proved beyond any doubt that not all prevocational boys are motor-minded, but that they profit in their academic work because of their interest in some form of real activity as found in shopwork. For these $2\frac{1}{2}$ to 3 hours of such work per day are advisable, and a very close correlation of teachers and pupils is essential to such work. Problems associated with prevocational work should be very practical, pertinent and timely, and there should be a rotation of shop activities semi-annually. If properly conducted, prevocational work insures a more thorough understanding by the pupil of what he knows than is true of the purely academic pupil.

3. All of those children who are not retarded or who do not want any considerable amount of such work should have a minimum amount of perhaps 2 hours a week.

4. Boston now maintains sixty special classes of fifteen to eighteen pupils each, with women as teachers. These pupils like to stay in the shops for longer periods, as motor work so-called possesses a very definite appeal for them. We can at least train such pupils so they may be at least partially self-supporting later in life.

The truest and best possibilities of vocational guidance are realized only by those who can bring to bear on this important work a broad and intensive experience obtained in industrial lines, and which they have the happy ability to combine with their academic training to good advantage.

Clarence O. Kingsley, supervisor of secondary education for Massachusetts, next spoke about "Enlarging the Appeal of Manual Arts in the Junior and Senior High Schools." He emphasized the existing relations between the Massachusetts Board of Education and all state continuation, state-aided and normal schools, and indicated the desire of that Board to vitalize and intensify the nature of the work being done in these institutions to the greatest possible extent. Reference was made to the high school in Calumet, in the heart of the Michigan copper district, which has a strong vocational department, and in which 40 per cent of all boys in the school have vocational training for 50 per cent of their entire school periods.

Mr. Kingsley feels that every job worthy of the name, that is assigned to pupils, should possess a definite appeal, and that pupils should be taught to

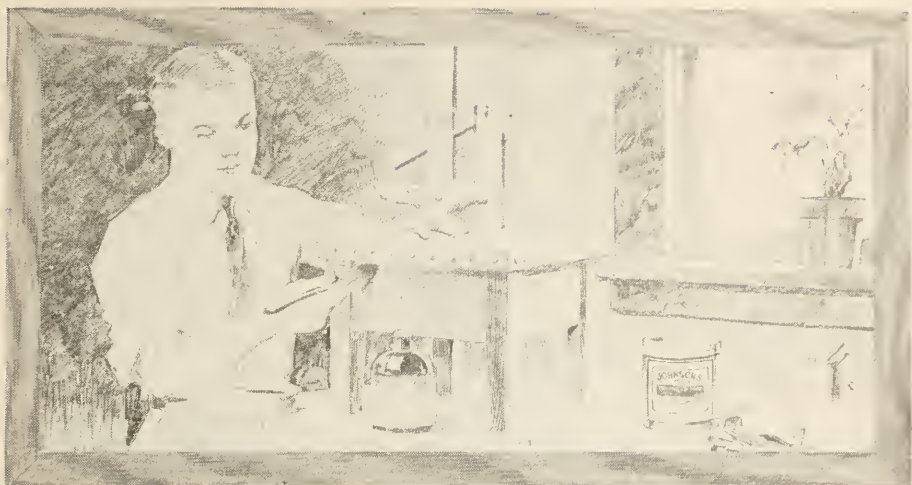

“Simply Stain It—Any Color— with Johnson’s Wood Dye”

JOHNSON’S Wood Dye is just the preparation for staining manual training models. It is very easy to use—goes on like oil without a lap or streak. It is made in thirteen attractive shades—which may be easily lightened and darkened. Complete instructions are given on every label.

JOHNSON’S ARTISTIC WOOD FINISHES

Johnson’s Artistic Wood Finishes are now being used in nine-tenths of the schools in the Country. They are particularly adapted for manual training work as they may be applied by the youngest and most inexperienced pupils with the best results.

The Johnson Wood Finishes most popular among Manual Training Instructors and Pupils are *Johnson’s Wood Dye, Prepared Wax, Under-Lac, Paste Wood Filler, Flat Varnish, Perfectone Under-Coat and Perfectone Enamel*. We have a very attractive exhibit of wood panels finished with these products which we are glad to send Manual Training Instructors who will give it wall space in their shop. Write for it.

Beautiful Instruction Book Free

Write for our beautiful new thirty-two page color booklet “The Proper Treatment for Floors, Wood-work and Furniture.” It is full of valuable information for Manual Training Instructors and Pupils. Do not hesitate to send for it. We will gladly furnish it upon request free and postpaid.

S. C. JOHNSON & SON, Dept. MT7, Racine, Wis.

“The Wood Finishing Authorities”
CANADIAN FACTORY—BRANTFORD



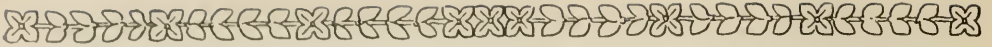

FIELD NOTES—(Continued)

consider wherein each particular job concerns community needs and how best to carry on their work to function properly with those needs. An altruistic spirit should characterize our work.

In the discussion that followed, the interesting fact was brought out by Mr. Brodhead that 80 per cent of our 14-to-16 year old boys are at present registered in high schools; this is assumed to be a record in that direction.

The Society voted to wait on Dr. Smith, Massachusetts Commissioner of Education, with the request that the Massachusetts Board of Education assign one educational representative on a full time basis to the particular subject of a vital and worth-while extension of manual and vocational training in the schools of this state.

THE DEPARTMENT OF MANUAL ARTS of the Boston schools has accepted another considerable assignment of refugee tables and chairs as a production problem in order to assist the Red Cross in their efforts to obtain more of these articles for use in the devastated areas of France and Belgium. Several hundred tables and chairs will be completed and ready for shipment by Christmas of this year, and it is proposed to include these articles in the course of study in the department shop; for at least one year, thus insuring an additional supply.

PAST AND PRESENT IN BOSTON

In 1891 Boston operated one school shop which was in charge of a woman teacher who is at present one of the most active teachers on the Boston payroll. In 1892 there were ten shops with five instructors. 1906 saw a considerable increase in the scope of the Department's work, and there were listed 42 shops, 40 teachers and two clay modeling teachers.

This year the Department of Manual Arts has under its direction:

- 64 Woodworking Shops (manual training).
 - 7 Woodworking Shops (with power machines).
 - 6 Electrical Shops.
 - 6 Machine Shops.
 - 7 Printing Shops.
 - 7 Sheet Metal Shops.
 - 2 Bookbinding Shops.
 - 1 Painting Shop.
 - 1 Class in Gardening.
- Teachers: 57 Woodworking (manual training).
7 Woodworking (power shops).
30 for other shops listed.
3 for clay modeling.

Gardening work represents 12,000 home and school gardens and ten canning centers, with 68 summer instructors in 52 districts.

In the high schools there are 10 shops with 13 instructors, the activities being of the co-operative type, as follows: machine shop, electricity, wood-working, auto mechanics and agriculture. This data does not include the Boston Trade School or Mechanic Arts High School, which are not under the jurisdiction of the Department of Manual Arts.

ONE OF THE MOST UNIQUE and helpful educational institutions of Boston has recently passed into history, and with it the most consistent and worth-while effort to provide apprentice instruction, in this section of the country, at least.

The Massachusetts Charitable Mechanic Association was founded in 1795 with Paul Revere as its first president, and when first incorporated in 1806 one of the articles of incorporation provided "That the annual income of said Corporation shall . . . be employed . . . to promote inventions and improvement in the mechanic arts, by granting premiums for said inventions and improvements; and to assist young Mechanics." In 1826 the Association was re-incorporated for a further term of years, this time with authority to "establish schools and libraries for the use of apprentices, and the improvement of the arts," and in accordance with this provision the "Mechanic Apprentices' Library Association" was formed in 1828. This organization had been anticipated for several years and in preparation therefor William Wood and others who were equally as interested had accumulated in 1820 a valuable "apprentices' library"—the first of its kind ever collected for this particular purpose—which was placed at the disposal of the Library Association when the latter was formed, and later its members were given entire control of the Library under the supervision of the Massachusetts Charitable Mechanic Association.

This excellent work was successfully carried on for over half a century with very gratifying results, and was discontinued only when such action was made necessary by the lack of interest and patronage which was occasioned by the gradual abolition of the apprenticeship system.

With the disappearance of these systems of education and training for the apprentices came a corresponding increase in the demand for skilled workmen, and as a result of this the Massachusetts Charitable Mechanic Association established the Evening School of Trades in 1900.

A supervising committee was first appointed, its membership consisting of two representatives for each trade to be taught, with the president of the Massachusetts Charitable Mechanic Association for its chairman, and after suitable quarters had

For the School or Factory

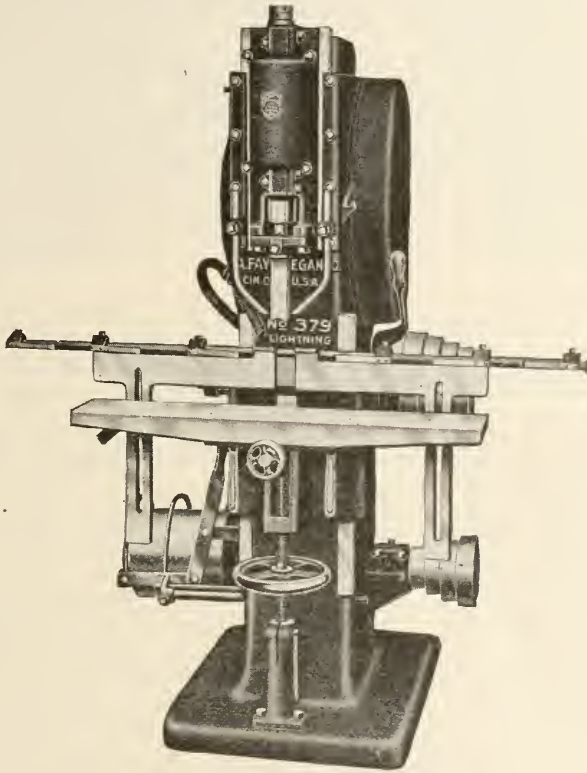

No. 379 "Lightning" Automatic Vertical Hollow Chisel Mortiser

FOR THE STUDENT AS WELL AS THE EXPERT

No. 379 is used in all the large Manual Training Schools in the Country
Cuts perfect mortises—square corners—sharp edges.

Requires little floor space.

Low operating power and up-keep costs.

Self-contained blower automatically removes chips.

Simple and easy to operate.

No pounding or jarring.

WILL MORTISE TO A DEPTH OF 5", OR THROUGH 10" BY REVERSING,
AND UP TO 1½" SQUARE.

Send for Bulletin 7-26

J. A. FAY & EGAN COMPANY

World's Oldest and Largest Manufacturers of Woodworking Machinery

Established 1830

730-750 W. FRONT ST.

CINCINNATI, OHIO

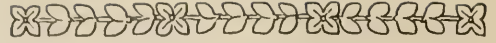
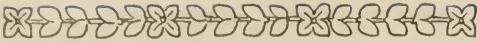

FIELD NOTES—(Continued)

been provided for in the Mechanics Building the school was opened with classes in carpentry, masonry and plumbing. This list of trades had been gradually increased in response to popular demand until it included carpentry, masonry, plumbing, drawing, electricity, sheet-metal work, sheet-metal pattern drafting, painting and tile setting, with printing scheduled for early attention.

The instruction in the various classes was in charge of men who were recognized specialists in their respective trades and their work was planned and carried out in such a manner as to benefit particularly young men who were desirous of perfecting their knowledge of the trades in which they were employed, with the purpose of qualifying them for a better grade of work, or for higher responsibilities in connection with it.

For over twenty years this interesting and consistent effort was carried on by the directors, but the limitations imposed by various labor organizations as to the number of apprentices who might be admitted to a trade were such as to discourage interest among young men in the trades and eventually the decision was reached to discontinue the work.

It is unfortunate that such a worthy project should have to be abandoned, but it is equally certain that the thousands of young men who have been trained in the M. C. M. A. Trade School of Boston are better men and better craftsmen because of such training, and the influence of this splendid work will be more and better appreciated in the future, perhaps, than it has even in the past. "*By their Works Ye Shall Know Them.*" —FRANCIS L. BAIN,

Formerly Director, M. C. M. A. Trade School,
Boston.

SOUTHEASTERN ITEMS

NORFOLK, Virginia has at present a very comprehensive building program in which, among other buildings, are two large junior high schools. Both of these buildings will have large shop facilities. T. S. Ridingsvard, director of vocational education, gives an outline of the work being done.

Three day unit trade courses are being conducted under the Smith-Hughes Act in the following branches: machine shop work, electrical installation and armature winding, and printing. Twenty-two ex-service men are being re-habilitated in the different shops.

In the high school, instruction is being given in machine shop work during the third and fourth year, and cabinet making and pattern making in the first and second years. In addition to the mechanical drawing offered in the above classes,

there are about 250 boys and girls taking mechanical drawing as an elective study preparatory to entering the various drafting rooms in Norfolk and vicinity.

The time allowed to vocational and manual arts is as follows: the vocational pupils receive three hours of shop instruction per day, the industrial arts pupils receive one hour and ten minutes per day. All pupils in the elementary schools above the fourth grade have industrial work. The fifth and sixth grades receive one hour and the seventh and eighth grades receive one and one half hours per week of shopwork. In addition to this, forty-five minutes per week are devoted to drawing.

In the evening courses, Smith-Hughes classes are conducted in machine shop work, armature winding, theoretical electricity, shop mathematics, blueprint reading and use of steel square for carpenters, architectural drawing, dress making, sewing, and cooking. Classes for negroes are conducted for automobile repairing, interior wiring, for light and power, plumbing, house carpentry, architectural drawing, home nursing, millinery, cooking, and sewing.

Raymond V. Long, supervisor in Virginia during the past year organized a general industrial school for the building trades at Bedford and a similar one at Salem.

The part-time school at the Norfolk Navy Yard, Portsmouth, Va. is particularly interesting in view of the fact that there are about 250 apprentices who give six hours a week to the particular type of work which supplements their occupation. J. W. Reaser is in charge of the work with three assistants, and is doing a most commendable piece of work.

FROM THE SOUTHWEST

IN THE seventeenth interscholastic meet held by the University of Oklahoma at Norman May 5-6-7, there were a number of interesting contests in manual arts and domestic art and science. A large number of students competed for the prizes offered.

There were four home economics contests; two in domestic science and two in domestic art. One of the home economics contests consisted of the making of a loaf of bread from a prescribed recipe. This was to be done before the time of the meet, and the bread was to be submitted for scoring. The other contest was the making of a lemon pie by a given recipe. This was a laboratory contest under the inspection of the judges. The domestic art contest consisted of the making of one gingham school dress according to certain specifications previous to the time of the meet, and of one laboratory contest in the making of decorative stitches.



The Teachers Tools

Use only the best that money can buy

Textbooks which make possible better instruction—Make education definite and positive—Save time for both student and teacher—Which have been tried out and proved successful under varied conditions—

These are the books to adopt for your students' use.

Tool Processes in Woodworking. By Laughlin. For beginners, either grammar grade or high school classes. Price, 88 cents.

Woodworking for Beginners. By Griffith. A remarkably simple treatment of elementary woodworking for students in the seventh and eighth grades. Price, 80 cents.

Essentials of Woodworking. By Griffith. A textbook written especially for grammar and high school students. The standard textbook on elementary woodworking. Price, \$1.44.

Woodwork for Secondary Schools. By Griffith. The most complete and comprehensive textbook on secondary school woodworking ever published. Adapted for a full four-year course. Price, \$2.64.

Wood Pattern-Making. By Purfield. A practical text for high school, trade school, technical school and engineering college students. Price, \$2.16.

Elementary Machine Shop Practice. By Palmateer. A practical text, well adapted for school and apprentice use. In many ways the best student text published on this subject. Price, \$1.50.

Elementary Forge Practice. By Harcourt. A textbook and shop manual adapted for use by students in high, vocational and technical schools. It presents a series of over forty projects, covering the fundamental operations. Price, \$1.50.

Correspondence Invited

The Manual Arts Press, Peoria, Illinois

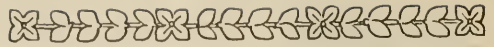

See these books for 10 days FREE

JUST OUT

Longfield—

Sheet Metal Drafting, \$2.25

A textbook on the underlying principles of sheet metal pattern drafting. The arrangement and presentation of the material have been successfully tested by several years of practical application in the teaching of the subject.

George—

Advanced Shop and Drawing, \$1.60

Emphasis is placed on drafting as applied to such special subjects as pictorial representation, patent office drawings, electrical drawing, piping layouts, structural drawing and sheet metal work.

French & Svensen—

Mechanical Drawing for High Schools, \$1.50

FREE EXAMINATION COUPON

McGRAW-HILL BOOK CO., Inc.
370 Seventh Ave., New York

You may send me on 10 days' approval

.....

.....

I agree to pay for the book or return it postpaid, within 10 days of receipt.

Signed

School

Official Position

Address

.....

M. T. M. 7-1-21

The contest in woodwork consisted entirely of exhibited articles. One piece of ornamental turning and one piece of furniture were asked for from each school. The contest in mechanical drawing was quite interesting. In this contest, one completed sheet was to be brought in by each contestant when entering, and three others were drawn during the contest.

The following schools were winners of the first prize in these contests: Bread making, Chandler; dress making, Okmulgee; domestic art laboratory, Tulsa; mechanical drawing, Oklahoma City.

There was a contest in water-color work, and one in decorative design. Tulsa and Oklahoma City were the respective winners of these.

The contest between school newspapers and school magazines was especially interesting. The newspapers and magazines were divided into three classes. In class A, Muskogee *Scout* came first; Tulsa *School Life* was second; and Enid *Quill Weekly* was placed third. In class B, the winners came in the following order: Marlow *Grey Wolfe*, Anadarko *Purple and White*, Muskogee *Eagle*. In class C, newspapers, the following awards were made: Wewoka *Little Tiger* first; Newkirk *Gold and Blue* second; and Sand Springs *Santonian* third. Among the magazines, the Oklahoma City *Student* won first prize.

AN EXHIBIT of specimens of art work, manual training and domestic art was held in connection with the Third District Federation of Women's Clubs which met at Tahlequah, Okla. May 11-13. Many prizes were offered for the best articles produced. The emphasis on the practical aspect of the exhibit is indicated by the following list of articles in art work. The best of each of these received an award of \$5.00: best gentleman's suit advertisement; best poster advertising the Studebaker automobile; best design for interior of living room; best design for afternoon gown; best poster advertising the Edison electric iron. Various business houses interested in the different kinds of articles advertised donated the prizes for this contest.

The best collection of public school art work showing a specimen of each kind of work done was awarded a silver medal by Mrs. J. Q. Adams of Claremore, while the second-best received a bronze medal from The Retail Merchants Association of Muskogee.

THE MANUAL ARTS department in Oklahoma City is looking forward to a great extension of its program for the coming school year. Three junior high school buildings, each with a capacity of 1200

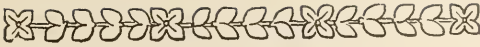

FIELD NOTES—(Continued)

students will then be ready for use. Each of these buildings provides for a complete program of wood-work and drawing. One large bench room, one drawing room, a wood finishing room, a stock room, a store room, and an office are set aside for the work in manual arts. In addition to these, provisions have been made for the use of other rooms in the future. The shops in the Central High School have been busy a large part of the time in building equipment for these junior high schools. One item of 500 drawing boards is indicative of the size of the orders that are being handled in the high school shop. The machine shops have re-built five automobiles this semester.

THE NEW VOCATIONAL HIGH SCHOOL building at Okmulgee, Okla. which has been under construction for a period of one and a half years is now completed. The cost of this building is \$300,000. The claim that it is the most complete building of its kind in the state can, no doubt, easily be substantiated.

The following types of work are now offered in the Okmulgee vocational high school:—Printing, (vocational and general); journalism; auto-mechanics; electricity (both vocational and general); vocational carpentry; general woodwork and cabinet making; general shopwork; mechanical, architectural, and related drawing; home economics, (vocational and general); commercial work, (including banking and accounting); and vocational science. There are finding or prevocational courses of nine weeks duration offered in all these subjects to the students of the seventh and eighth grades.

One of the new courses for this year which has proved to be popular with students and parents alike is the general shop course. One section of this work was organized at the beginning of the present school year. Immediately upon the announcement of the purpose of the class and the scope of work to be covered, the limit of membership was reached, and many were unable to gain admission. At the close of the first semester, another section was added. This class filled up quite as rapidly as the previous one. About fifteen boys applied for admission in excess of the number that could be enrolled. This "general shop course" is offered to boys of the freshman year in the high school. The work consists of approximately six weeks of activity in each of the following branches:—wood work; painting and wood-finishing; sheet-metal work and repair; furniture and household repair, bicycle repair, glazing of windows etc.; forging; and cement work. The work here is presented in such a way as to



Kewaunee

Laboratory Furniture

Ask half a dozen instructors who use it why they prefer Kewaunee Laboratory Furniture and you will get half a dozen significant answers. One will say, "It's more convenient;" another, "It's more practical;" another, "It's stronger;" another, "It lasts longer" and so on.



Manual Training Bench No. 1904

Has accommodations for three students.

The Kewaunee Book will interest Educational Executives who are considering the installation of new manual training equipment. Illustrates and describes our complete line and explains our free planning service.

Write us at Kewaunee for your copy.

Kewaunee Mfg. Co.
LABORATORY FURNITURE EXPERTS

111 Lincoln St.

KEWAUNEE, WIS.

New York Office, 70 Fifth Avenue

BRANCH OFFICES:

- | | |
|-----------------|---------------|
| Chicago | Little Rock |
| Minneapolis | Denver |
| Kansas City | Spokane |
| Phoenix | Oklahoma City |
| Atlanta | Jackson |
| Alexandria, La. | Los Angeles |
| Columbus | Toronto, Can. |



The Best of the Better SAWS

When arranging to add new or additional equipment to your manual training or vocational departments select the best saws--SIMONDS. They stand hard usage and hold their cutting edge. Get Simonds Hand Saws, Back Saws, Coping Saws and Hack Saws.

Write for Catalog and Prices

SIMONDS
Manufacturing Co.

"The Saw Makers",
Fitchburg, Mass.

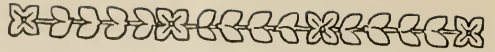

FIELD NOTES—(Continued)

give direct application to the needs of the home. At the same time, the broadening value of the course is not lost sight of. The students receive such technical and civic information thruout the course as will tend to give them a broad outlook upon the industrial world, and make them sympathetic in their future dealings with men of all classes. The course is expected to be one of the most profitable of all classes in this department. The very basis upon which this course is built seems to be such as to justify the entrance of every boy in school. The opportunities of entering will be extended for next year so that practically every boy who wishes to enroll may do so.

—E. E. ERICSON.

FROM PENNSYLVANIA

THE following items were taken from the *News Bulletin* of the Pennsylvania Society for Vocational Education:—

"The industrial department of the Allentown Schools is manufacturing domestic science tables, manual training benches, desks, sewing tables and cabinets for use in their school department. This work brings a net saving of about \$6,000 to the District. The pupils are being taught the best commercial methods of production on modern machines, especially adapted for this kind of work."

An evening class in oxy-acetelene welding with a registration of about 60 men, employees of the P. R. R., local garages and repair shops, is proving to be an interesting and successful enterprise in industrial education at Altoona. Fifteen men at one time are given an intensive course of six weeks, including welding of sheet-metal, cast iron, cast steel, cast aluminum cylinders, pipe welding and brazing. The course content is largely confined to the principles of welding and of the welding apparatus. The equipment includes the Torchweld, the Oxweld and the Rego outfits.

A new Miehle Cylinder press has been installed in the Casino building at Johnstown for the purpose of training pupils in the printer's trade. This is a wonderful piece of machinery costing about \$4,000, but it is expected that in the long run the printing will pay for the machine. The present equipment of the print shop, among other things, includes also a linotype machine, two job presses and a complete assortment of type. It is estimated that over \$3,000 worth of printed matter was turned out by the pupils of the vocational schools during the past year.

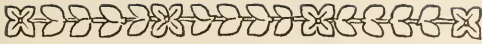

FIELD NOTES—(Continued)

VOCATIONAL COURSES GIVEN BY
KNIGHTS OF COLUMBUS

THE Knights of Columbus of the United States are employing the giant surplus left in their treasury after the conclusion of the Great War to giving to ex-servicemen college educations, especially in the field of vocational training.

In one of their schools, located in a Mid-Western city, there are at present in training over 900 young veterans in the department of automotive engineering, and 200 others in commercial work—these in addition to the numbers taking the usual collegiate subjects. This school is St. Xavier's, located at the heart of Cincinnati, admission to which may be had on the presentation of discharge papers. The fiscal year extends from October 4th to June 3rd, classes being held at night from 7:30 to 9:30, five evenings a week.

While elementary courses in various fields are offered, most of the men who attend have had some higher education, and come there to fit themselves for a specific line of work. They are not attending school to escape from going to work while living at dad's expense; they have a very serious purpose. Hence the most popular classes are the ones in vocational training—courses being given in a certain branch whenever twenty men elect it.

"It is interesting to note," says Dr. Robert Lavell, head of the institution, "that the classes in auto-work almost equal, in their numbers, all other courses combined.

"Next in point of numbers come the classes in salesmanship and accounting. So great is the demand for highly trained accountants that there has been difficulty in securing instructors.

"After these three are the classes in applied electricity, business English, advertising, mechanical drawing, and traffic management.

"So popular have these courses become that many members of the Knights, not ex-servicemen, have asked to join, and are admitted on payment of a tuition fee which goes into the fund for the free education of the ex-soldier. We give certain courses not offered elsewhere, and consequently some disabled soldiers, in training at the Ohio Mechanics Institute near by, have enrolled for this special work.

"The biggest surprise we have met with in conducting this school," Dr. Lavell—himself an ex-serviceman, by the way—continued, "is how hard the men work in the classes. They come here after a hard day's work; here, voluntarily, they work equally hard.

WILEY TEXTS
for YOUR SHOP STUDENTS

Mathematics for Machinists

By R. W. BURNHAM.

The Wiley Technical Series,

Joseph M. Jameson, Editor.

Gives the practical calculations every machinist needs to know how to make. An excellent text for vocational courses.

229 pages—5 by 7—175 figures—\$1.75

Practical Trade Mathematics

By JAMES A. MOYER and

CHARLES H. SAMPSON.

Suitable for students specializing in the various trades. There are two groups of problems—the first, for electricians—the second, for the other trades.

172 pages—5 by 7—155 figures—\$1.50

Practical Shop Mechanics
and Mathematics

By JAMES F. JOHNSON.

Gives an outline of the elements of mechanism applied to everyday work of the shop, in such a manner as to be readily understood by the average mechanic.

130 pages—5 by 7—81 figures—\$1.40

Cass Technical
High School Series

Preparatory Mathematics for Use
in Technical Schools

By HAROLD B. RAY and

ARNOLD V. DOUB.

70 pages—4 7/8 by 7—70 figures—\$1.00

Mathematics for Shop and
Drawing Students

By H. M. KEAL and C. J. LEONARD

213 pages—4 7/8 by 7—188 figures—\$1.60

Mathematics for Electrical Students

By H. M. KEAL and C. J. LEONARD

230 pages—4 7/8 by 7—165 figures—\$1.60

SEND THE COUPON—Examine Them Free

USE THIS COUPON

John Wiley & Sons, Inc.,
432 Fourth Avenue, New York City.

You may send me the following on 10 days' approval:

- Burnham's Mathematics for Machinists
- Moyer & Sampson's Practical Trade Mathematics
- Johnson's Practical Shop Mechanics and Mathematics
- Ray & Doub's Preparatory Mathematics for Use in Technical Schools
- Keal & Leonard's Mathematics for Shop and Drawing Students
- Keal & Leonard's, Mathematics for Electrical Students

I agree to pay for the books or return them within 10 days of receipt.

Also please send me a copy of your Vocational News and put my name on your mailing list.

Name.....

Address.....

If teacher, state school.....

If not teacher, give reference.....

M.T.M. 7-21

MONARCH LATHES

from 10 to 30 inch swing

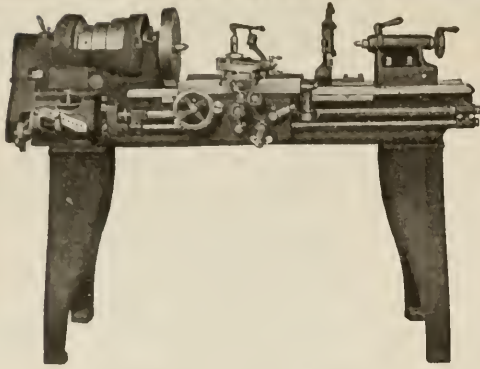

12-inch quick change lathe.

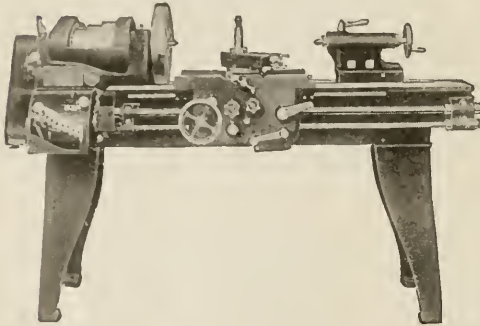

14-inch quick change lathe.

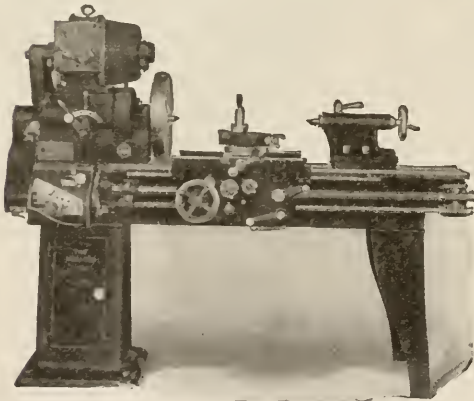

16-inch Motor driven geared head.

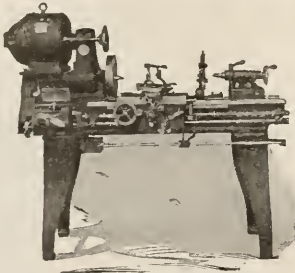

12-inch Motor driven lathe.

offers the ideal lathe for the manual training school. They are furnished in any style and with practically all attachments desired.

MONARCH lathes are low in price yet are as accurate as the highest priced lathes. By installing **MONARCH** lathes you can in many instances put in **two** **MONARCH** lathes for the same cost as **one** of the high priced lathes.

MONARCH lathes are in use in many factories and tool rooms with lathes costing almost twice as much doing just as much and as accurate work.

It is not necessary to pay a high price to secure a good engine lathe.

Let us send you our catalog and list of manual training schools using the Low Priced **MONARCH** lathes.

THE MONARCH MACHINE TOOL CO.

103 Oak St., SIDNEY, OHIO

Manual Training Magazine

JULY, 1921

MANUAL ARTS IN ILLINOIS

LAWRENCE F. ASHLEY

Director of Manual Training at The Eastern Illinois State Teacher's College

THE purpose of this article is to set forth all facts available in regard to the present status of manual training in the state of Illinois, and to show the significance of these facts in the formulating of adequate curricula for this line of educational activity in teacher-training institutions of this state and of other states of which Illinois may be a type. Such information should be a guide to students preparing to teach, to teacher-training institutions in placing their graduates, and to teachers in the field, as well as others interested in education.

There are 372 towns and cities in the state not including Chicago which have a population of 1,000 and over, according to the last census (1910) available. To each of these towns and cities a carefully prepared questionnaire was sent. Two hundred of them, or 54 per cent, were returned with the questions properly answered by school officers. The returns were then tabulated for the various cities differing in population by 5,000 and for the three sections of the state—north, central and south, each covering about forty degrees of latitude. A final grouping was made for the whole state with the findings summarized. Limited space will necessitate confining statements to the summary, with a few of the most significant facts about the other groupings, with present trends, and with suggestions.

Of the 172 superintendents who failed to report, nearly all were in cities of 5,000 and under. A large enough proportion

of this class did report to make it possible to arrive at a very accurate estimate for these cities. The only large cities failing to report were Belleville, Evanston, Jacksonville, Lincoln, Mt. Vernon and Peoria. Of the 167 towns with a population of 5,000 and under, 78 per cent had no manual training. Forty-nine per cent of this group were in the north section of the state; 59 per cent were in the central section; and 85 per cent were in the southern section.

From the total findings for the state were brought out the facts that nearly one-third of all the pupils receive some form of manual training; that most of these are in the grades or in the Junior high school; that one-fourth of the manual training shops in the state are in separate buildings especially for this work; that one-half the cities have manual training in their grade buildings; that three-fourths of the high school buildings have manual training shops in them. The other shops are located on different floors of school buildings with the larger per cent on the first floor. In general the shops are well lighted, but 15 per cent of the shops have to use artificial light all the time; 81 per cent are provided with artificial lights. Almost no work is carried on in manufacturing plants.

A large variety of manual training work is offered thruout the state, but in the order in which the various lines of work are emphasized by the various cities reporting, the following table indicates

the stress that teacher-training institutions should place upon them. The percentage of the cities of the state which offer:

Bench Woodwork.....	96
Mechanical Drawing.....	76
Machine Woodwork.....	42
Carpentry.....	35
Pattern Making.....	34
Automobile Instruction.....	19
Farm Mechanics.....	15
Machine Shop (Metal).....	13
Printing.....	13
Forge Work.....	12
Art Metal Work.....	12
Foundry Work.....	7
Plumbing.....	5
Electrical Work.....	5
Sheet-metal Work.....	4
Brick and Cement Work.....	3
Shoemaking.....	3
Other Work.....	5

While the foregoing table indicates the order in which the various lines of manual work are being developed, it also indicates that those lines of work which are at present of most significance in industrial production are receiving the most attention. Many of the cities reported in separate letters that they intend to put into operation other lines of activity than they now have as soon as sufficient money is available.

Other facts of significance shown by the returns from all parts of the state are: that 94 per cent of the teachers of manual training are men; 55 per cent are high school graduates; 62 per cent are normal school graduates; 28 per cent are college graduates; 65 per cent have had more than one year of professional preparation for teaching manual arts. It is customary to believe that manual training teachers as a group have less preparation for their work than have the teachers of other subjects. This report will prove the reverse to be true for Illinois.

Athletics proves to be a very popular subject for manual training teachers to handle. In 19 per cent of the cities of the state the young man who can coach is the man who is employed for manual training. This sounds as if he might be employed to teach manual training principally because he can coach, whether his preparation for manual training has been adequate or not. This is sometimes the case, especially where the applicant holds a normal school diploma, for the diploma qualifies him to teach in Illinois any subject which is taught in the elementary schools of the state, whether or not he has really had sufficient preparation in the special subject. Eighteen per cent of the cities of the state require manual training teachers to teach other subjects also.

In many instances superintendents reporting seemed to have some difficulty in deciding about the emphasis and the method of instruction used in their systems, but most of them replied that the emphasis was prevocational, and the method that of individual instruction. A large per cent replied that the emphasis was cultural and that the class project method was best. The teachers outline most of the work. The superintendents help with about one-fourth of the plans. In most instances the director of manual arts is a teacher.

There are two reasons for admitting and permitting manual training in our system of education. The first reason, which should be the only reason, instituted three centuries ago by Comenius in Europe, and later by Pestalozzi and his contemporaries with such success that the idea was transported to America and has been rapidly growing in importance for the last half century, needs no further comment here. The other reason which has hardly been suspected is brought to light with especial emphasis thru the reports of the superintendents of the state.

Manual training when introduced in some schools is immediately looked upon by the superintendent or the school board as the logical means of securing repairs or additions to school apparatus. Thru such reasoning these things can be had with a minimum of red tape and expenditure of money, and at times when apparatus could not otherwise be secured. It does not matter, as a rule, what work is being carried on in the manual arts department, when the need for repair or added equipment comes, the superintendent requests that other work stop until this repair work or the equipment is made. If the opinion of the manual training teacher is asked about the advisability of doing the work, at the time it is wanted done, he, knowing that his position depends upon his willingness to co-operate, at once assures the superintendent or the board that it is the proper thing to do. The manual training shop is thus made the dumping ground for all odds and ends of work that need be done about the school premises.

Of the cities of Illinois, 69 per cent say that the course in manual training includes the making or repairing of school equipment. Thirty-four per cent report that they do this work at stated periods, but 55 per cent of the superintendents of the state report that the manual training class must make or repair school equipment at any time such repair or equipment is needed.

What is wrong with this method of procedure? A careful examination of all the reports received shows that when the attitude of the parents or of the student body is not excellent toward manual training, the classes make or repair equipment at any time it is wanted. Whether it has any instructional value to the student or not, the students are made to do manual work for the community. This work may be monotonous and repetitional in character. They are thus exploited for the

benefit of the superintendent, the school board, or the community. The doing of such work may require the effort of a layman. Where this is true, in order that the work be properly done, the teacher must do it, and thus cheat the pupils of his time for instruction as well as the layman of his rightful employment. In this way he forces antagonism between the school and the labor union. Are such methods correct from the standpoint of pedagogy?

All teachers will agree that a pupil makes progress only in that system which is rational—that system which is carefully worked out and which has a logical beginning and a worth-while end in view. Consequently, all school work must be carefully planned and so organized that there will be no breaks in the line of advancement for the pupil. This is true of all subjects for all classes of schools. This careful order of procedure must not be broken or altered if the desired results are to be accomplished. Some head school officers do not have the proper regard for this law. Others seem to be ignorant of it. To illustrate, the superintendent desires certain information from each parent in the city and this will necessitate the writing of a great many similar letters. Finding his stenographer already loaded with work, and knowing that letter writing is a branch of English work in school, he goes to the English teacher, who is working on Tennyson's poems at the time, and requests that the class stop their work for the present and write the letters for him. After a pupil writes one, very little that is of instructional value remains in writing more. Further, what is the result with regard to the study of Tennyson? Again, the president of the school board has accumulated a quantity of statements which need auditing. He takes them to the class in mathematics who have had this kind of work and are

now beginning factoring in algebra. He requests that the algebra be laid aside and the whole class work on his statements. Such action as these examples illustrate is of course absurd and is almost obsolete in academic work, yet, 55 per cent of the cities of Illinois allow the manual arts department to be kept in a state of disorganization thru the same kind of imposition. It is a very common thing for the head school officer to request that the class in manual training repair this or make that regardless of the plans of the teacher. As a consequence, the amount of good that comes from manual training falls far short of what can be accomplished under proper methods and supervision.

The general public is back of the work as is shown by all reports. There is just a little friction between the manual training department and the academic departments of schools. This may be due to misunderstanding and ignorance regarding the aims of the other departments of the school. It may be due to jealousy arising from the fact that the manual training teacher is paid more than some of the other teachers. This latter fact is brought about by the necessity for school boards to pay the manual training teacher a salary commensurate with what he can get in industry in order to secure his services.

A trend that is worth noting is that the strictly cultural aims of traditional courses in manual arts are gradually giving way to manual training which is related directly to present industrial conditions. Sixty-one per cent of the cities of the state favor the latter method. This does not mean that the cultural phase is lacking but that

the latter method may include cultural with vocational aims.

In regard to the administering of vocational education in the state, most cities will have one man direct both this line of work and the manual training work.

Some facts brought out by the sectional grouping and classification are worth attention. The southern section of the state offers less manual training work than either of the other sections. Fewer pupils in southern Illinois have an opportunity to take manual training than in the rest of the state. In the cities of the state with a population of 5,000 or less offering manual training, only bench woodwork and drawing are given. The little city of Bridgeport is an exception to both of the above statements. It makes a better showing for its size than many of the larger cities. As the cities increase in population to 10,000 there is but little difference in content, except that as more money becomes available, machine woodwork is added to drawing and bench woodwork. In cities having a population of 20,000 and over, all lines of activity are represented except brick and cement work, plumbing and farm mechanics. These lines of activities, however, were found in a few of the smaller cities.

It is interesting to note that in all of the large cities of the state, the attitude of the parents toward manual training is 100 per cent, the attitude of the student body averages 95 per cent, and the attitude of the academic teaching corps averages 90 per cent in sympathy with the work. In 85 per cent of the same cities the manual training offered is related directly to present industrial conditions.

There are owls who to adapt the world to their own eyes would always keep the sun from rising.

—HORACE MANN.

THE USE OF A SCALE FOR JUDGING MANUAL ARTS TEACHERS

PAUL V. WOOLLEY

Head of Manual Arts Department, New Junior High School, Muncie, Indiana

THE use of the accompanying scale for judging manual arts teachers, it is believed, may be made profitable from two standpoints: The first is that thru honest self-survey and self-rating we teachers may take the first step toward greater efficiency, greater service and larger positions of trust and responsibility. The second is that supervisors and administrators in general have a convenient and fair means of judging us for purposes of marking and promotion.

That we can all profit by the use of some reliable sort of efficiency ratings is made plain by H. O. Rugg in his article in *The Elementary School Journal* of May, 1920. He further shows why many ratings are inadequate and unreliable measures of success in teaching. The rating scale proposed herewith is not a new idea and possesses features of the best rating scales which have been tried out. Mr. Rugg has prepared a similar scale to apply to teachers of the elementary grades. The idea is his. I have simply made it applicable to teachers of the manual arts in particular.

The chief causes of failure of other schemes of rating in the past very likely rest with the teachers themselves. We are exhibiting the reverse side of our human nature when we do not accept a rating from above by an administrative officer. Yet some of us believe that it is the bitterest medicine that does us the most good, and since we must be judged anyway, why not have it done in a scientific way? If our success grade is not 100 per cent we might profitably spend some time examining ourselves according to such a schedule, both by self-rating and by conference with our administrative officer. After all, improvement of

our services can never be great unless we admit our weaknesses, then we can receive stimulations from within and be in a better mood to accept those from without.

As Mr. Rugg says: "It will be a first step in self-improvement. It is important that you stand high in these qualities. . . . For effective teacher rating, both teacher and administrator should rate and confer on specific qualities which make for good teaching. . . . Conditions are set up by which there can be sympathetic understanding between the teacher and administrator concerning the work of the teacher. Misunderstandings will be avoided thru a meeting of the two minds."

This scheme has been developed thru several months of study and conference with other teachers. The writer believes that great good will result if we take invoice of ourselves just as any merchant takes invoice of his stock in trade and prepares to launch out on a more successful sales campaign the coming year. This scale consists of a series of questions which the teacher will check "low," "fair," "good," or "excellent," according to his honest belief of what he deserves on each and every question of the five groups.

Rate yourself now. Ask your employer to rate you, then think about it during the summer vacation. This is a good time to go out and get a good perspective of ourselves and to go over our mental machinery; clean it up, get new bearings, grind its valves with a compound of grit and oil of harmony, lubricate with courtesy which prevents friction in all human machinery. Get loaded with information, tank up with spirits of sacrifice and

A RATING SCALE FOR JUDGING
SELF IMPROVEMENT

For analyzing and rating the teacher's qualities by the teacher himself
and by the administrator or supervisor.

I. SKILL IN TEACHING	Low	Fair	Good
To WHAT EXTENT—			
1—Does he know the subject-matter of his own field?.....			
(a) Does his grade of license indicate a knowledge of his subject?.....			
(b) Does the exhibit of his own handwork show skill, good taste and originality?.....			
(c) Do his demonstrations before the class show a knowledge of the fundamental operations?.....			
2—Does he know the subject-matter of related fields?.....			
(a) If a wood worker, does he know the fundamentals of art, freehand drawing, mechanical drawing, electrical work, etc.?.....			
(b) If a metalworker, does he show a knowledge of woodworking, physics, mechanism, auto-mechanics, etc.?.....			
(c) Does he use illustrations from other subjects and relate shopwork accordingly?.....			
3—Does he select subject-matter effectively for assigned readings and discussions?.....			
4—Are his aims of teaching clearly defined? Does he show evidence of having:...			
(a) Made any outline or keeping a note-book showing aims and plans of his own and suggestions of his administrator?.....			
(b) Planned each lesson specifically to carry out such plans?.....			
(c) Made provision for a clear distinction between (1) "formal skill," (2) "information" and (3) "problem solving"?.....			
(d) Given pupils a clear idea of the aims of each lesson?.....			
5—Is he skillful in conducting the class?.....			
(a) Does he always stand up during a demonstration, discussions or regular shopwork?.....			
(b) Is he resourceful in organizing and thinking "on his feet"?.....			
(c) (1) Is he quick to turn pupils' questions into occasions "for driving home the facts"?.....			
(2) Does he express himself clearly?.....			
(3) Are his questions systematically arranged?.....			
(c) Has he skill in developing new phases of the work?.....			
(1) Are lessons well related to previous ones?.....			
(2) Are models, samples and pictures or other means used to arouse and hold interest?.....			
(3) Is there proper reference to blueprints?.....			
(d) Is skill shown in making assignments?.....			
(1) Does he help pupils understand HOW to study?.....			
(2) Was the assignment more than just a formal announcement of so many pages?.....			
(3) Does it leave the pupils with a taste for more knowledge?.....			
6—Has he insight into "How children learn"?.....			
(a) Does he keep his vocabulary within the comprehension of the pupil?.....			
(b) Does he endeavor to discover pupils' weaknesses by keeping a record of each individual's work and studying the same?.....			
(c) Does he endeavor to discover pupils' individual differences?.....			
(d) Do the finished products, both projects and pupils, reflect good training?.....			
AVERAGE SKILL IN TEACHING			

Name of Teacher.....
School.....
Date of rating.....
Final average of five qualities.....

MANUAL ARTS TEACHERS IN SERVICE SURVEY

Rate yourself by checking one of the four columns for each question.
Then find the average rating in percent.

II. SKILL IN THE MECHANICS OF MANAGING A CLASS	Low	Fair	Good	Ex.	IV. QUALITIES OF GROWTH AND KEEPING UP-TO-DATE	Low	Fair	Good	Ex.
<p>WHAT EXTENT—</p> <p>Are materials always ready and machinery "ready to go" so that no interruptions occur in class?</p> <p>Do pupils attend naturally and spontaneously to the work?</p> <p>Does order or discipline need specific attention?</p> <p>Is routine (such as getting tools, shop clothes, blueprints and materials) economically and systematically organized?</p> <p>Are materials and equipment in the room neatly and effectively arranged?</p> <p>Are the pupils taught to put tools away and to "keep house"?</p> <p>Does he pay attention to the details of heat, light, safety appliances and general welfare of his students?</p>					<p>TO WHAT EXTENT—</p> <p>1-Does his library indicate interest in cultural and professional books, magazines, etc?</p> <p>2-Does he participate in discussions at educational meetings or contribute to magazines and professional papers and journals?</p> <p>3-Does he take extension or correspondence courses or attend summer sessions, etc?</p> <p>4-Does he experiment with new ideas of others?</p> <p>5-Does he do research work of his own?</p> <p>6-Does he visit other schools and compare notes with other manual arts teachers?</p> <p>7-Does he cultivate the acquaintance of highly qualified teachers and leaders of industries?</p> <p>8-Does he co-operate in investigational work, surveys of industries, etc?</p> <p>9-Does he engage in shopwork of his own or gain other practical experience during summer months?</p>				
RATING IN PERCENT					RATING IN PERCENT				
III. TEAM WORK QUALITIES	Low	Fair	Good	Ex.	V. PERSONAL AND SOCIAL QUALITIES	Low	Fair	Good	Ex.
<p>WHAT EXTENT—</p> <p>Does he cooperate with and remain loyal to his administration?</p> <p>Does he willingly take orders and advice from "higher ups"?</p> <p>Does he cooperate with other teachers in school problems and extra-curriculum activities?</p> <p>Does he contribute to faculty meetings, suggesting plans for group improvement of the school?</p> <p>Does he shoulder responsibility for his own acts?</p> <p>Do pupils go to him voluntarily for advice and conference?</p> <p>Does he go out of his way to advise and help students, and if necessary, using time outside of school hours?</p> <p>Does he acquaint himself with the vocational activities and needs of the community from which his pupils come?</p> <p>Does he tactfully acquaint himself with the "home conditions"?</p> <p>Does he take part in community activities outside the school?</p> <p>Does he ever criticise his fellow teachers harshly?</p> <p>Are his records and reports in on time and in good form?</p>					<p>TO WHAT EXTENT—</p> <p>1-Does he attract friends?</p> <p>2-Does he show interest in what others are doing?</p> <p>3-Does he meet people easily?</p> <p>4-Is he neatly attired and well kept in matters of dress and personal cleanliness?</p> <p>5-Is he well versed in social proprieties?</p> <p>6-Does his regard for himself assume merely a degree of self-confidence and not of egotism?</p> <p>7-Is he effectively aggressive in conversation and conference?</p> <p>8-Does he possess initiative and tenacity in the matter of carrying thru what he undertakes?</p> <p>9-Is he observing and alert?</p> <p>10-Is his general disposition "sunny" and his voice pleasant to listen to?</p>				
RATING IN PERCENT					RATING IN PERCENT				

(With acknowledgements to H. O. Rugg for general idea.)
Paul V. Woolley, Head Manual Arts Dept.
New Junior High School, Muncie, Ind.

service, get your battery recharged and, if you have the right connections, everybody will feel the presence of a live wire and, if you have a self-starter, you will

not have to get out and crank up when you return to the old shop where furniture and men are in the making.

TEACHING THE ELEMENTS OF THE PROCESS OF PAPER-MAKING

MARTHA BEESON

Teacher of Printing, Seward Junior High School, Minneapolis

PAPER-MAKING has been found most fascinating and instructive for school children, and once the underlying principles are understood and demonstrated, there are many interesting and

trying various experiments, and with very interesting results.

The process is simple, but directions must be carefully followed to ensure success.

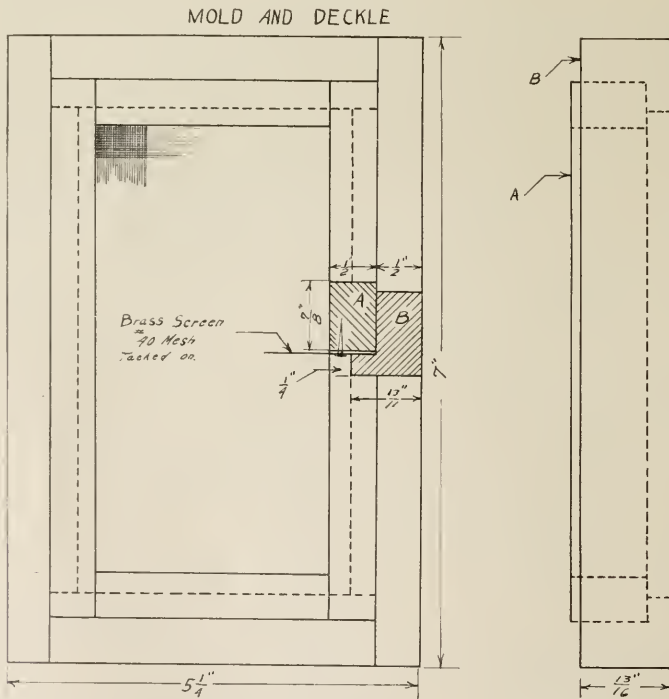

valuable "follow-up" lessons to be developed—for instance, the various kinds of paper, their uses, etc.

Paper-making carries with it the joy of creating things. Interest is keen thruout the entire process, and many children have become so enthusiastic that they have carried the work into their homes,

Materials:

- Old linen cloth (the older the better)
- Laundry starch
- Borax
- Dye
- Mold and deckle
- Clean muslin cloths (8" x 10")
- Hot flat-iron



WRINGING

TRANSFERRING PULP
FROM SCREEN TO MUSLIN
FIG. 2

SUBMERGING MOLD AND DECKLE
DRAINING OFF WATER



REMOVING MUSLIN
THAT ADHERED TO
PAPER

REMOVING
MUSLIN FROM
PAPER

FIG. 3

PRESSING

PULP BETWEEN MUSLIN
READY TO BE PRESSED

Ironing board

Directions:

Cut linen in pieces about $\frac{1}{2}$ " square. Pull all the threads apart so that no two are left crossing each other. Hold this bunch of threads in the tips of the fingers of the left hand, and with sharp scissors cut *very fine*. This is the only tedious

threads should be cut over and over again until there are none left $\frac{1}{8}$ " long. The finer the threads are cut, the better the grade of paper.

The lint is then put into a small dishpan, or bucket, and sufficient water added to make it about the consistency of thin gruel. To this add laundry starch until

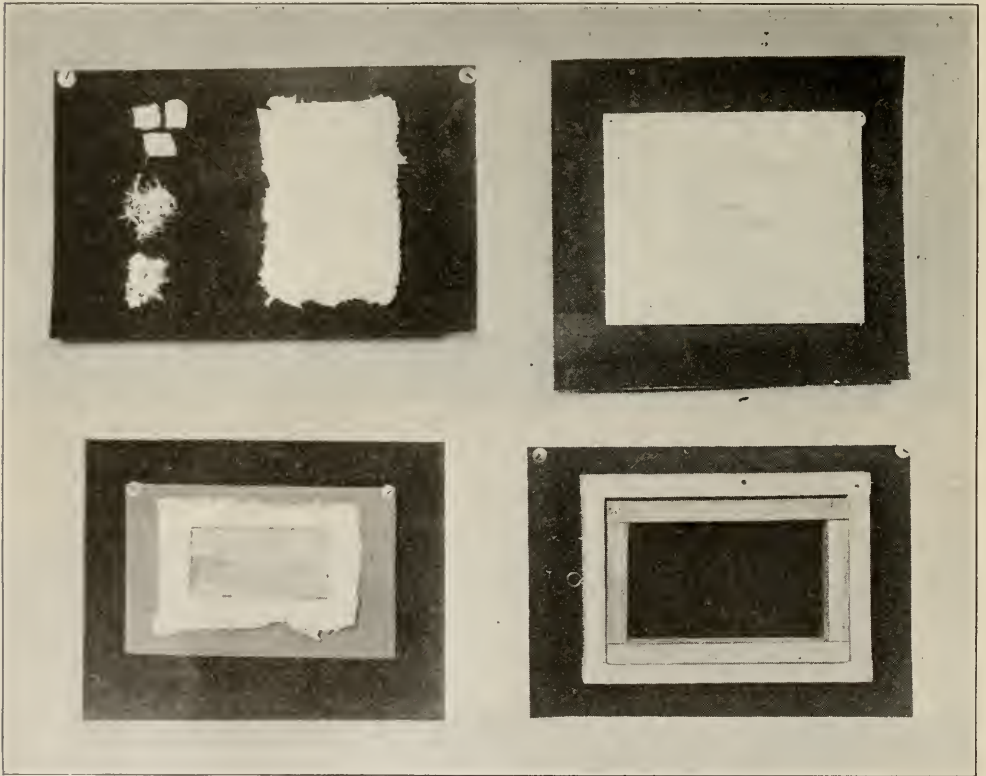

FIG. 4.

part of the entire process, but unless it is cut very fine—almost like powder—the results are not good.

A good live story read aloud during this part of the work (the preparation of the lint) does away with the tediousness so satisfactorily that it is almost unobserved by the workers.

Beginners will wad the lint if not watched, and once wadded, the paper will not be smooth and even. These

it takes on a milky appearance. Add one heaping tablespoon of borax to about one gallon of pulp. If tinted paper is desired add any good dye. Colored inks answer the purpose and are simple to use.

The pulp is now ready for the "dipping process."

Before "dipping," stir the pulp, care being taken that it is not in motion when the "dipping" begins. Hold the mold and deckle, Fig. 1, in a horizontal posi-

tion—thumbs on the middle and top of the sides. *Keeping* this horizontal position, submerge the mold and deckle, Fig. 2, and bring carefully up. Sometimes repeated attempts are necessary before securing an even layer of pulp on the screen. The pulp is sufficiently thick when the screen can not be seen. Beginners are apt to get the pulp too thick. Drain off the water, lay the mold (pulp side down) on one of the clean pieces of muslin. (The photographs, Figs. 2 and 3, show how this and the following steps are taken). Lift one end of the screen slightly, allowing the opposite end to rest on the muslin. With a knife loosen one edge of the pulp, then turn mold directly back, and it should leave an even layer of pulp on the cloth. On top of this put another piece of muslin. Lift carefully, by slipping the hand under. Run thru the laundry wringer, taking care not to let any wrinkles form, also to keep it from touching any part of the wringer except

the rollers, as the pulp is easily disarranged. It should be kept in a horizontal position and requires three pairs of hands to do it well, Fig. 2.

Before ironing, place a dry cloth on top and bottom of damp ones, Fig. 3. Iron on both sides with a *hot* iron. When thoroly dry, remove the cloths. The last one may stick slightly to the paper, in which case, pull the cloth away from the paper, not the paper away from the cloth. Iron directly on either side of the paper. If directions have been carefully followed, the result will be a pleasing piece of paper.

The paper may be decorated and made into attractive Christmas cards, etc., Fig. 4.

The children's joy is well worth the time spent, to say nothing of the educational value of the work.

We have found that cooking the pulp, and the use of caustic soda are not necessary, and their elimination simplifies the process.

THE BOOK BEAUTIFUL

Thought, skill and refined taste are needed to produce a beautiful book. Art may enter largely in the making of a book: in the harmony of cover and contents; in the cover decorations; in the adaptation of type to subject-matter, to size of page, to length of line, and other elements; in the arrangement of title-page, chapter heading, and other features; in the choice and use of decorations, head lines, initial, and color; in the selection; and use of illustrations; and in the harmony between what the book says and its bodily presence. To look at a book with critical interest is to practice one's esthetic sense on one of the most important of all products of human skill, and the product best fitted to serve as an object of art study. Buyers and readers of books may learn to criticise them wisely, and may then ask that good taste and high skill be put in their production; thus will the noblest and most important of all the arts thrive among us.

—JOHN COTTON DANA.

VOCATIONAL EDUCATION IN ONTARIO¹

JAMES C. MILLER

Assistant Director of Industrial and Technical Education

ONTARIO and Quebec are, and probably will continue to be, the most industrial of the Provinces of Canada. At present Ontario leads Quebec in population and in the number and variety of industrial enterprises. In area it is not as large as Quebec, but it is somewhat larger than the combined areas of Ohio, Indiana, Illinois, Michigan, Wisconsin, Iowa, Minnesota and West Virginia. The distance on the transcontinental line of the Canadian Pacific Railway from the extreme east, near Montreal, to the extreme west, near Kenora, is about the same as that from New York City to Minneapolis. From Detroit and Niagara on the south it stretches to the north and west for a distance greater than that from Chicago to New Orleans. Along the south western part of Hudson's Bay it has a coast line over 500 miles in length. The many rivers which drain the great forest areas on the northern slope of New Ontario empty into the Bay in this region. The greater part of James Bay is south of the latitude of Edmonton or Prince Rupert. The present population of this vast area is about 2,750,000. Over eighty per cent. of this population is located along or south of the main line of the Canadian Pacific Railway.

ENABLING LEGISLATION

In August 1909 Dr. Seath, the superintendent of education for Ontario, was authorized to make a careful inquiry into the problems of industrial and technical education with a view to legislation. After extensive personal investigation in the United States and Europe, he submitted his report and recommendations in De-

cember 1910. It was on the recommendations in this report that the Industrial Education Act of 1911 was based. This Act has been amended from time to time as the needs of the service have required.

In June of 1910 the Dominion Government appointed a commission to investigate and report on technical and industrial education as it might be related to the needs of Canada. The commission, under the chairmanship of Dr. James W. Robertson, made extensive investigations in the United States and Europe and submitted a voluminous report in 1913. The World War delayed further action by the Dominion Government until 1919 when the present Technical Education Act was passed. This Act provides a sum of \$10,000,000 to be divided among the Provinces on the basis of population and distributed over a period of ten years. Payments to the Provinces are contingent upon at least equivalent expenditures by the Provincial governments. The Act is administered by the Dominion Department of Labor, and a Dominion Director of Technical Education, L. S. Gill, is the executive officer in immediate charge of its administration.

ADMINISTRATIVE ORGANIZATION

In Ontario and in the Western Provinces also the educational service is represented in the Provincial Cabinet by a Minister of Education. The Department of Education, under his immediate direction, is considered one of the most important of the departments of the Government, and usually claims the largest portion of the annual legislative appropriations.

Since the position of superintendent of education for Ontario was abolished, the

¹This article does not account for changes since February, 1921.

director of industrial and technical education reports directly to the Minister. The director and his staff have an inspectorial and supervisory relationship to the work throughout the Province. The extension of vocational education and the training of those who are to teach, to organize and to supervise the work in local communities are also under his direction.

In the local centres the Boards of Education appoint advisory committees—industrial, commercial, agricultural—according to the needs of their community. These committees are composed of eight (or twelve) persons, of whom four (or six) must be members of the Board and two (or three) employers and two (or three) employees. The advisory industrial committee has administrative charge of industrial, technical and art education for its community. It determines the program, employs the staff, and prepares its reports and budgets for submission to the Board of Education. The Board of Education can refer back or even reject the proposals of the committee, but it cannot amend its programme. The Board cannot, under the law, reject the proposals of the advisory committee without granting the committee a public hearing on the matter at issue.

SUBSTANTIAL PROGRESS—DAY SCHOOLS

The only industrial and technical day schools in operation in Ontario at the time the Industrial Education Act was passed in 1911 were those in Hamilton and Toronto. Both of these institutions were having the usual pioneer experiences in temporary and inadequate accommodation and with insufficient financial support. While development has been retarded seriously by the War and its aftermath of public debt and high prices, substantial progress is being made.

The Central Technical School in Toronto is now splendidly housed and equip-

ped at a cost of \$2,000,000. The construction of the first of the three projected branch technical schools has been authorized and \$400,000 provided for the first building unit. Work on this building is to be started this year. In Hamilton about a year ago the first unit of the new technical school building was completed at a cost of \$200,000. This year the construction of the central unit of the building is to be started and the \$500,000 needed for its completion has been provided. A new technical school building has been provided in London at a cost of \$250,000 and one in Ottawa at a cost of \$175,000. In Fort William, Sudbury and Niagara Falls new buildings are approaching completion at a cost, respectively, of \$240,000, \$180,000, and \$160,000. A new building for the Ontario College of Art, to cost \$125,000, is now under construction.

In several municipalities by-laws have been passed providing for the funds necessary for vocational school buildings, but, owing to the excessive costs, the construction of the buildings has not been commenced. Sarnia has voted \$350,000 for a composite secondary school, of which \$125,000 will be for the unit set apart for the classes in vocational work. Kitchener has voted a similar amount for a school of the same type. Sault Ste. Marie has voted \$150,000 for a vocational school. Windsor and Walkerville, just across the river from Detroit, have voted to pool their interests in one central technical school which is to cost approximately \$500,000.

The grand total in completed buildings is \$2,625,000; in buildings now under construction \$705,000; and in buildings not yet under construction, but provided for, \$900,000. The relation of these expenditures for buildings to the enforcement of the Adolescent School Attendance Act, which becomes effective in 1922 and 1923, will be apparent to all.

SUBSTANTIAL PROGRESS—EVENING SCHOOLS

The development of the evening vocational classes has been much more rapid than that of the day schools. As existing buildings and equipment used for other purposes in the day time can be made available for the use of evening classes, the question of accommodation has been less difficult. In the school year 1918-19 the number enrolled in the evening vocational classes was, in round numbers, 16,000. In 1919-20 this enrollment had increased to over 26,000. While the returns for the current school year are not yet available, the indications are that this remarkable increase has been held. In the autumn of 1919 evening schools were organized in thirteen new centers, and in the autumn of 1920 seven additional centers were added to the list. Evening classes are now being conducted successfully in fifty-eight centers in Ontario.

VARIETY OF INDUSTRIAL AND COMMERCIAL ACTIVITY IN ONTARIO

By far the greater part of the manufacturing in Canada is to be found in Ontario and Quebec. While Ontario is far in the lead, Quebec has made rapid progress in recent years, particularly in the manufacturing of rubber goods, textiles, boots and shoes, and pulp and paper. The major lines of activity in Ontario to which a vocational education program has to be adjusted are:

1. Wholesale and Retail Business, including Importing and Exporting.
2. Banking, Brokerage and Insurance.
3. Metal Products—Hardware, Machines and Tools, Automobiles, Heating and Ventilating Equipment, Electrical Equipment, Farm Implements and Machinery, Steam Power Equipment—stationary, marine and locomotive—and Railroad Equipment.
4. Wood Products—Buildings, Furniture, Pulp and Paper; Farm Equipment, Vehicles and Automobile Bodies.

5. Mining—Gold, Silver, Copper and Nickel.
6. Railroad Operation Apprentices, Shopmen, Trainmen, Enginemen, Telegraphers.
7. Marine Engineering and Navigation.
8. Stationary Steam Engineering and Steam Power Plant Operation.
9. Hydro-Electric Power Plants, transmission of electrical energy for lighting, heating, street and inter-urban electric railway purposes.
10. Home-making and wage-earning occupations for girls and women.
11. The skilled and semi-skilled trades.
12. Agriculture.
13. Municipal, Provincial, and Federal Civil Services.

DOMINION AND PROVINCIAL GRANTS

Provincial grants paid to the local advisory industrial committees during the calendar year 1920 amounted to \$630,-202.29. To earn this grant the local communities had to spend an equivalent amount in salaries, buildings and equipment. The total amount actually expended by the local authorities for vocational education was, therefore, in the neighborhood of \$1,500,000. The grants are calculated on the basis of a schedule established by regulations.

The grants received by the Province from the Dominion Government for the Dominion financial year (March 31st, 1919, to March 31st, 1920) was \$224,383.-30; the amount of Dominion grant which can be earned by the Province for the next Dominion financial year (March 31st, 1920, to March 31st, 1921) is \$259,-528.10.

FORWARD-LOOKING ADJUSTMENTS

1. *As to General Organization:*
 - (a) An effort is now being made to have the Provincial Governments and the Dominion Government co-operate in establishing a national institution for the training of the instructors, organizers, supervisors and directors needed in the field of vocational education throughout the Dominion. The success or failure of

this effort for co-operative action will be known in the near future. If the plans for such an organization do not materialize, Ontario will be forced by the pressure of its own needs to develop an institution of its own. Meantime, the usual summer session methods and evening training courses in the field during the school year will be continued. While it is too early to indicate in detail the more fully developed plans, there is no doubt but that it will include such essential arrangements as:

(b) The training institution, if for Ontario's own purposes, will be under the general supervision of the provincial director of technical education and will be supported directly by the Provincial Government through the Department of Education.

(c) The institution will have a home of its own in sufficiently close relationship to a vocational school to make it convenient to use the vocational school for purposes of observation, practice teaching, demonstration and experiment. Such a close association with a real day, evening and part-time vocational school will be deemed an essential part of the arrangement, whether Dominion or Provincial.

(d) The principal and staff of the institution will be kept in intimate touch with the service in the field and will be associated with the officers of the technical branch of the Department of Education in working out solutions for field problems.

2. As to modifications in the law and regulations:

(a) At present the commercial and agricultural schools and classes are not on the same footing, from the standpoint of Provincial grants, as the technical, industrial and art classes. It is proposed to have all vocational schools come under a common schedule of grants. This will mean a substantial increase in the grants

for commercial and agricultural education.

(b) In order to simplify the local administrative arrangements, especially in the smaller centers, it is to be made possible to replace the three advisory committees—industrial, commercial, agricultural—by one vocational education committee empowered to perform all the functions now assigned to the three.

(c) At present vocational classes can be organized only in centers having a secondary school. Provision is to be made whereby vocational classes may be carried on in centers not large enough to have a high school—mining centers, pulp and paper mill villages, railroad divisional points, industrial villages.

(d) With the enforcement of the Adolescent School Attendance Act in view, provisions are being made to facilitate making and keeping up to date a census of all minors in each community.

3. As to special professional problems:

(a) To co-operate with the local communities in developing adequate ways and means for effective vocational counselling.

(b) To foster the establishment of co-operative effort by bringing into closer association the vocational schools and those engaged in business, industry and agriculture.

(c) To co-operate with other departments concerned in arranging for the vocational rehabilitation of those disabled in industry.

(d) To co-operate with the local authorities in making the necessary industrial studies to determine the most suitable content, arrangement, and methods of instruction to be used in the courses given in the vocational schools.

(e) To co-operate with the local authorities in the development of the most suitable arrangements and courses for the part-time classes called for by the Adolescent School Attendance Act.



EDITORIAL REVIEW FOR THE MONTH

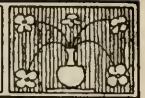

TOO MUCH OF A GOOD THING

WHETHER you are a resident of Illinois or not, be sure to read Mr. Ashley's article in this number. Read it so as to get a bird's-eye view of manual training work in the public schools of a typical Mid-Western state; read it to learn certain desirable tendencies in such work; but read it more especially to find out what he says about the fact that "55 per cent of the cities in Illinois allow the manual arts department to be kept in a state of disorganization" thru requiring that this department make school repairs whenever such repairs are needed and therefore without reference to the time when they can be made to the educational advantage of the student and presumably without any reference as to whether they ought to be done by the students at all.

The present condition of repair work in the manual training schools of the state seems to us to be in very large measure traceable to the survey of the schools of Springfield made several years ago, in which the surveyors recommended that the repair work of the schools be done in the manual training departments. This recommendation we have always believed, was a great mistake, though its purpose, which was to loosen up some of the stereotyped courses of the time, may have been commendable. But the result has been that the recommendation has been made an excuse for turning the manual training shop into a repair shop with an economic motive instead of an educational one. In the face of such a recommendation and the consequent action of many school officials, much credit is due to manual training teachers who have kept the educational motive uppermost. A little pressure upon some

manual training teachers to break away from their "perfect schemes" may have been a good thing for them and for their schools, but there is no justification for some of the actions that have followed in the wake of the survey.

This reminds me of one of Dr. Prosser's delightful darky stories:—

There was a darky mammy who had a beautiful patch of cabbages but the drouth came and the cabbages became more and more withered until she feared the crop would be entirely lost. Being a very religious darky, she went into her cabin and knelt down and prayed, "O Lord, for the sake of thy humble servant's cabbage patch, do send us rain." But no rain came. The next day she prayed the same prayer, and then again the third day. That night there came up a great cloud and a torrent of rain fell on the cabbages. It rained so hard that it began to wash them out of the ground, and the darky mammy saw that the final destruction of her patch was at hand. So she knelt down again and prayed, "Dear Lord, it am true that thy servant did pray for rain, but dis am simply ridiculous."

THE BOY PROBLEM

HERE is a letter from a personal friend that gripped me so that I have asked permission to print it incognito. I think it should be an inspiration to some of the readers of this column to know that there are others who are up against real problems and are meeting them heroically. It may help them, too, to know that this young superintendent of public schools, after being especially successful in dealing with boys, both as teacher of manual training and school principal, has reached

the conclusion that the "high school age is too late to reach most boys" and that the Boy Scout Movement represents the most effective present means. And the real motive behind this superintendent's reason for seeking a change of position—his desire to be of the greatest possible service to boys—is well worth emulating. The American elementary schools are in great need of more such men who know and can influence boys from 10 to 15 years of age.

Dear Mr. Bennett:

Your letter came this morning and I have time to answer it at once. I would like to be able to drop in and talk with you but of course that is impossible. I guess I must have given you the impression that —— has not been kind to me. That is hardly the truth because I have many friends here and there is no doubt that 90 per cent of the population support me. This year has gone very well and perhaps next year would too. There was not one word of criticism until the tax notices came out and as they were much higher than the previous year there were several reactionaries who started to complain that the schools were wasting money. One banker, a former teacher of fifteen years ago, led the opposition and became a candidate for the Board. He was elected by my friends to keep him quiet. However, since becoming a member he has opposed every constructive idea, will hear nothing of a Smith-Hughes agricultural course, is opposed to scientific farming, wants no domestic science or manual training, wishes only a few subjects taught that will "TRAIN THE MIND."

He is not a man who will see the light. He is out-voted on the Board, but he has a loud mouth and can stir up a good deal of dust among his following. I suppose I should fight it out for the good of the town, but I hate to fight when it is possible to get into a place that does not require it.

This is one of the oldest towns in the state. It is very conservative and has more than its share of retired farmers who oppose all progress. Up until this time the younger element has stood back and let the conservatives rule. I started a good many projects. One was to open the theatre and operate it with high school pupils. I had the Methodist minister to buck in this matter. He was not going to have a theatre in the town. However, I have kept open, have given very excellent shows, and now the minister's daughter takes her turn selling

tickets. This show has been an asset, as it has kept the young folks at home when formerly they went to —— for their amusement. However, there are still some who buck the playhouse, and the community still does not take the pride in it that the project deserves.

I have used this as a medium for financing educational pictures for the children. This has been very successful. I started a boy's club, with a reading room, checkers and a pool table. In this I was supported by the large majority, but a few opposed the table. It was too much of a one man proposition, however, and I have closed the room.

Last night the citizens organized a Community Club along the lines I planned out for it. I had been president of the Commercial Club, but this organization only touched a few. This Community Club appeals to the whole population and the citizens are responding well. We now have almost 200 paid up members. We have a paid secretary to look after the collection of dues, correspondence, etc. She is a local woman. This club has five committees: agricultural, civic, recreational, educational and commercial. I believe it is going to function.

Taken all in all I believe my year has been very fruitful, but I am not satisfied. I have been re-elected, but I believe I can do bigger things elsewhere. In the first place I wish to have a settled feeling. I have spent over \$600.00 the last three years in moving. Then I wish to have a bigger field of action in so far as younger boys are concerned. I am positive that the high school age is too late to reach most boys. The grades are the place to direct a boy in the right path. I hope for a grade school principalship in —— . The minimum pay equals what I receive here and the opportunities for advancement are greater. I do not believe it is a job which will fill a person with ambition—one of these principalship—nor does one have such a good opportunity to show off in a big system, but one has the advantages of the city and few of the disadvantages of the small town.

I believe in time I will work into the Boy Scout Movement. I believe it holds the only solution of the boy problem. This boy problem is a serious one today.

This is a long letter but I hope it will place my viewpoint before you more clearly. I didn't want you to get the idea that I have become a drifter, nor that I had made serious mistakes this year. I entered this job with my eyes open and after a summer's study at the university of small town psychology. I used the most approved methods

and while the results are not perfect, I believe they are at least gratifying.

Very sincerely yours,

THE INTENSIVE PLAN OF NEWARK REACHES CINCINNATI

IN CONVERSATION with Elmer W. Christy at the meeting of the Western Arts Association I learned that Superintendent Condon of Cincinnati is interested in the Intensive Plan of organizing manual arts instruction that has been worked out in Newark, N. J., and that Principal Hanson of the Burnet School, Newark, had been invited to come to Cincinnati to explain the plan. I immediately asked Mr. Christy to let me know the results of the meeting. The following letter gives the facts:—

On Friday afternoon, May 13th, Frank Hanson, Principal of the Burnet School, Newark, N. J., spoke to 1500 public school teachers in the auditorium of Hughes High School, Cincinnati.

Mr. Hanson's topic was "The Intensive Plan in the Elementary Schools Co-ordinating with the Departmental Plan." Mr. Hanson spoke of his experience with such a program during the past three years as principal of a school of 1400 pupils. Readers of the Manual Training Magazine are familiar with this experiment in Newark because of articles which have appeared in previous issues. By dividing the program of the year or semester into cycles and having daily lessons in the so-called special subjects for a cycle of approximately five weeks instead of weekly lessons thruout the term, he believes that they have accomplished a great deal more than under the old system. Mr. Hanson's argument in favor of this scheme appealed strongly to the teachers of shopwork who often become discouraged because of the long time it takes to accomplish anything in construction work and the necessity for reviewing when the individual lessons are so widely separated. By means of the daily lessons, not only is there less need of review, but the teachers are required to care for only one-fourth as many different students per week as under the old system, thereby enabling them to become better acquainted with the individuals.

After the regular teachers' meeting the teachers of all special departments gathered in the school dining room for a dinner which had been arranged for by the Industrial Arts Club, with Mr. Hanson as the guest of honor. Superintendent Condon of

the Cincinnati Schools congratulated the teachers of various special departments for coming together in a common meeting and reaffirmed his appreciation of the newer forms of education represented by these departments. At this meeting Mr. Hanson undertook to answer a number of questions which were raised by those present, and apparently was able to overcome most objections. One of the interesting results of Mr. Hanson's visit is the fact that a principal of one of the larger schools in Cincinnati has asked that he might reorganize his school program along lines similar to those followed in Newark. We shall watch with interest the development of his plans.



JOHN CALLAHAN

JOHN CALLAHAN BECOMES STATE SUPERINTENDENT IN WISCONSIN

BEFORE this number of the Magazine reaches its readers John Callahan will have taken up his new duties as State Superintendent of Public Instruction in Wisconsin. On July 1st he succeeded Charles P. Cary, who has held the position since January 1, 1903. Among vocational education men thruout the country Mr. Callahan is known as the genial and clear-headed state supervisor from Wisconsin who always contributes something sane and practical to any subject he discusses, but only a few of them know him as he deserves to be known. *The Wisconsin Journal of Education* says of him:—

Those at all familiar with Wisconsin's educational history during the last quarter of a century know John Callahan and his true worth. It happens that from infancy he has lived in Wisconsin, and has received his training and had his school experience in this state. He is, therefore, thoroughly familiar with our educational needs. As a district school teacher, grade and high school principal, city superintendent, institute conductor, and head of the vocational work of this state, Mr. Callahan has made a record that fully justifies the high honor the people have conferred upon him. During his career as a schoolmaster he has been honored by his co-workers with the headship of two state sectional associations and of the state teachers' association. His years of pronounced

successful labors on the legislative committee of the Wisconsin Teachers' Association have resulted in progressive educational laws being put upon the statute books.

Far beyond the state's borders the name Callahan has been linked with successful vocational education.

He comes to his new work fortified by a most successful teaching experience and possessing those human qualities of comradeship and cooperation, together with a record of intense devotion to duty, which unquestionably spell progress for the next four years at least of Wisconsin schools and Wisconsin educational institutions—and that means a better citizenship and a better state.

A POINT OF VIEW

THE TECHNICAL CURRICULUM AND THE HIGH SCHOOL

NOTE:—The following letter with its answer is published at the suggestion of a number of my students who discussed the questions in class. Further comment is unnecessary.

LETTER

"Professor Arthur Dean,
Teachers College,
Columbia University,
New York City, N. Y.

Dear Sir:—

The city is erecting a new building for the Boys' Vocational School, and the high schools in the city are overcrowded. We are face to face with many questions as to the relations between the various types of schools, particularly between the vocational schools and the technical high schools (or the technical curriculum in high schools.) The high school teachers are studying the situation and you will greatly help our study by letting us have your estimate of the value of technical high schools—perhaps following the lines suggested by the questions below:—

2. Should this curriculum be omitted from the high school on the ground that boys who desire work of that sort may attend the vocational school?
3. Is it better that a technical curriculum be offered as one of several curricula in a general or cosmopolitan high school or should there be separate technical high schools?
4. In general what do you conceive to be the field of the technical curriculum in high schools as differentiated from the vocational schools?

Respectfully yours,
Secretary, Schoolmasters
Association."

ANSWER

My dear Mr.—

Your interesting questions are at hand. I cannot answer them in full for two reasons: First, to answer them adequately would require a hundred pages; second, the answer depends upon local conditions and I have no survey data upon which to base conclusions.

As a matter of fact you open up the whole question of the value of a cosmo-

1. In the technical curriculum a boy spends from a third to half of his time in drawing and in joinery, metal, pattern-making, and machine shop, and the rest of his time in high school mathematics, English, science, etc. Should such a curriculum be offered in our large industrial cities?

politan high school as compared with a differentiated high school system. That is the question which is at the basis of your inquiry. Another question quite as searching and equally basic, is that of evaluating the technical work in the regular high schools.

In a small city there can be only one high school. That is a self-evident truth. In a larger city of from 50,000 to 150,000 population which is compact in its distribution of people and where the school is centrally located with relation to car lines and general convenience the high school may well be of cosmopolitan type (but truly cosmopolitan and comprehensive, not a pretence at democracy.) In a city like yours one of the ten largest cities in the country—with its people, industries, commercial houses, and car lines well spread out the question is not so easily answered. Supposing you have an East Side, North Side, South Side, and Central High School each with a commercial, industrial, college preparatory, and homemaking department, to what extent can you develop adequate commercial and industrial work? In your "regular" high schools you have such departments. They consist of courses in joinery, cabinet making, wood-turning, pattern making, forging, machine shop practice, stenography, type writing, etc. You have also general courses in mechanical drawing. You call these courses "technical." This is a fortunate terminology as they are surely not "vocational." The courses in English, science, history, and mathematics are practically common to all groups—college, commercial, industrial, or homemaking. Your students may choose a foreign language in place of shopwork or shopwork in place of foreign language. They may elect Latin instead of drawing or forging instead of music (anvil chorus equals music scale in educational values.) They

may graduate from some one of four courses or from fifty-seven pieces of four courses.

Now I am not objecting to this procedure. Far be it from me to criticize the American high school. It is fearfully and wonderfully made. There is nothing like it in the world. It is much more popular than the vocational schools. The increase in attendance has been enormous. Everybody goes to it even if they do not go thru it. It is a going institution. The public supports it with little question. The parents work and sacrifice for their children to stay in it. The teachers are paid more for less work than the grade teachers. The equipment is used on a higher per capita cost than the elementary schools. It is as popular in the public education process as the movie is in the commercialized educational scheme. And worse, or better, the public vocational schools look like a plugged nickel as compared with the high schools in their buildings, enrollments, salaries, number of graduates and per capita costs.

I have several questions to raise. Your "regular" high school has a college preparatory department. Do you appreciate how closely its work functions with its purpose? Do you realize how adequately it does its job? Do you know that it is the one course in your school of which a careful survey has been made of the "job analysis" and in which adequate courses have been prepared to meet the job? The college preparatory course is definite, purposeful, and highly efficient. To these pupils you apply the selective process; for them have small classes. To them you give much attention in order that the "school may not be disgraced" at time of college entrance or certification.

I commend you for a fine piece of survey work in so far as college preparation is concerned. Now for another series of questions. Have you ever made

a survey of the industrial and commercial jobs? Have you any fear that the industrial boys "will disgrace your school" because they do not make drawings in accordance with actual practice?" Have you a list of the requirements of employers for entrance upon work? Do your industrial courses meet the apprenticeship requirements of industry? Have you specific knowledge that a stenographer needs for life or for her vocation a knowledge of algebra, geometry, bookkeeping, stenography, Spanish, commercial law, arithmetic, accounting? Is it essential that a "homemaker" have trigonometry, advanced algebra, French, "falling bodies," "moments of inertia," "angular velocity," etc?

Now I do not know these answers myself. I have my suspicions. I am making it my business to find out. It is our business to know the requirements of the job of working and living of these children. There must be life and work requirements as definite and purposeful as those of the college entrance certifications. It is a mighty difficult task facing us. Any one-degree-above-amoron sort of person can make up college entrance courses. All he has to do is to send for the college requirements and print the list. It fills only one sheet and has an air of finality. If the college is "liberal" it will accept for entrance shopwork, drawing, cooking, sewing music, art, hygiene, etc. And then it is only a question of adding points or credits to make up the options and other points to make up the required studies. The latter plan takes a three-degree-amoron clerk to check up the points.

But to discuss how to fit those who do not go to college to live and to work is a ticklish proposition. If you and I were to attempt to function our industrial and commercial courses to life and to vocations, where would we start and

where would we come out? What criteria lie at the basis of their functioning? The world of commerce, industry, and the home are very complex. The subdivisions of even skilled labor; the technical knowledge needed in certain fields of industry and commerce; the broadly human and scientific approach to household problems; the quality and quantity of specialized, of unskilled, and semi-skilled work in industry and commerce; the relationship of the school work in English, history, mathematics, and science to the fields of industry, commerce and home; the question of whether the high school should not throw the burden of productive vocational training upon industry and commerce and teach part-time work in correlated book work within the school; the question of whether all English and history should not be given to all pupils from the same angle of approach and method for the sake of establishing democratic ideas of the expression of citizenship, quite irrespective of the vocation followed; the question of whether science and mathematics would not have more disciplinary value, and therefore, true liberalizing value if they were tied up to vocational activities; the question of whether the establishment of a junior high school providing presentation of vocational opportunities would not materially assist in having the departments of cosmopolitan high schools more definite in their vocational aim—these points and perhaps fifty others come up.

These are some of the questions which we must consider. No longer can you and I afford to "make up" the industrial and commercial courses of study by first writing down the college preparatory course in a column and then starting the industrial course at the right, making a column which looks like the left column except it is "easier," has no foreign

language (or else made elective), inserts shopwork and drawing, and then says "specialization is allowed in one shop subject for the fourth year." Then start a third column for the commercial courses on a similar basis. In other words you and I have taken our "job analysis" from a column of words to the left instead of going out to find out "by what do people work and live."

Let us drop this matter at this point. You practically asked the question "What is the field of a technical curriculum in a cosmopolitan high school?" I have been in the work for twenty-five years, as the pupil in a manual training high school, the teacher in one, an administrator and professional student of one; and I do not yet know the answer to your question. I do know that the motor area value of handwork is best expressed and gained in the very early years of childhood. I do know that from the age of ten years to thirteen that the spiritual and mental growth out-cropping from activity work reaches a high state of correlation. I do know that from the age of thirteen until sixteen are the best years to give children industrial, commercial, and other work-a-day world experiences, in order to open up their eyes to the industrial, commercial, and household world. I do know that vocational education begins just before one goes to work, continues during work, and ends with the grave. I do know that vocational education is not entirely concerned with joinery, which is now practically obsolete in these modern days of building construction; that forging is a vocation in the discard because of drop-forging principles; that in commercial work one person is not employed as expert in bookkeeping, stenography, type-writing, Spanish, accounting, and business law. I do know that cooking and sewing are not as large problems in the home as husbands, babies, telephones, gas

bills, ice men, rent collectors, trap plugging and leaky faucets. I also know that a cosmopolitan high school having a "technical curriculum" is more popular, more attractive, apparently more successful, and in the minds of the public more worth-while than the traditional high school, barren of anything except book work. I do know that giving a little of everything and allowing equal credits for anything whether it be cooking, Greek, drawing, biology, athletics, music, Spanish, or calculus, makes a strong appeal to American ideals of secondary education. I do know that vocational schools when put off in a corner of the city in an old building, robbed of gymnasium, assembly halls, and athletics, diluted extensively in enrollment by the scrubs, mongrels, and lay-me-downs, of the public elementary schools—I know that such vocational schools have small numbers, stand low in public estimation, cost a good deal of money to carry on, and are under constant fire and "have a hand to mouth existence."

My list of "do knows" is not so large as a possible list of "don't knows." Space is not adequate to give the latter list. I do not know the cultural value of the theory of limits, coat hangers, $a^0 = 1$, n th term of $(p+q)^r$, frying an egg, date of raid of Brown's Crossing, taboret or projection of a point on a 45 degree plane. I do not know what "copra" is or where the Sargossa Sea is or the depth of the ocean off the west coast of Japan. I have no idea how many angels can be balanced on the point of a needle, and membership in the Society of Those Who Understand Einstein's Theory of Relativity is not yet open to me.

I wish I did know these things for then I could be an editor of an Encyclopedia or work for Edison (see his recent tests). But I have had to work and live. I had to get ready to work on a job and to

advance in that job. I had to eat, sleep, play, think, and read. I have had to earn money and spend it, buy clothes and food, take care of my body, participate in public affairs, drive a car, fish, have a family, swim, get and hold friends, know when to buy coal, how to borrow (and collect) money, pay for a house, listen to music, go to theatre, etc., etc. And to tell you candidly I have not had the time nor the brains to accomplish adequately these things. Combine these jobs with a vocational job of being a teacher, machinist, plumber, clerk, or stenographer with all their complex relationships and you and I are "stumped." One thing is sure, and that is that we know, or if we do not we ought to, that much of the high school work is inadequate preparation for life and work. It does not function with work jobs and some of us doubt whether it functions with the job of living.

I think I better leave the letter at this point. I am very much interested in vocational education. It is an attempt on the part of society to fit persons for profitable employment and to provide persons already employed with additional education helpful to their vocation.

Your city is large enough to support some real vocational education. It is industrially and commercially very important. It has diversified industries, its products are nationally known, and its industries call for skilled and intelligent mechanics. Vocational preparation of young people for living in ——— and the vocational re-education of people already at work are important matters to the people of your city—too important to fall merely into the mud-hole of academicness, prejudice, cosmopolitanness, or specializationness.

—ARTHUR DEAN

WASHINGTON CORRESPONDENCE

LEGISLATIVE COMPLICATIONS

THE past month has been crowded with events having a bearing on prospective legislation of interest to educators. In my last letter I discussed the provisions of the bill providing for a Department of Public Welfare, as outlined by Brig. Gen. Sawyer, the President's personal representative, before the committees of the Senate and House. At the time I wrote it was expected by a number of observers with whom I talked that this bill would be enacted into law within a very short time.

In the hearings which have been held during the past few weeks, however, very definite and determined opposition has developed from several different directions, so that while there are those still who predict that a department of public welfare will be created within two weeks,

I have been told by several persons who have had considerable experience in Washington to expect that action will be postponed indefinitely.

NATIONAL EDUCATION ASSOCIATION ORGANIZES VERY EFFECTIVE PLEA

IF ACTION is prevented or postponed indefinitely the National Education Association will be entitled to much of the credit, because of the very determined stand taken before the joint committees on the disposition which this bill proposes to make of education. It has been my privilege to attend a number of hearings before committees of Congress, and with a single exception this was the most effective presentation of a case that I recall having heard.

On Thursday, May 12th, Hugh S. Magill, field secretary, representing the

National Education Association, requested permission to present to the committee the evidence to substantiate a statement made by Judge Towner, to the effect that the educators of the country, and the friends of education generally, would not be satisfied with the place assigned to education as a division of the proposed department of public welfare. The committee agreed, and set the time for Wednesday, May 18th, at 10 a. m., for this purpose.

At this time Mr. Magill made a preliminary statement in which he called attention to the experience of the several states which have legislated on this subject.

While departments of education were created years ago in the older states and were established at the organization of the newer states, we find that departments of public welfare have been created in only a few of the states, and that in very recent years. In those states where such departments have been established they have in no instance included education. The functions of a department of public welfare have been considered separate and distinct from the functions of a department of education.

NECESSITY OF CHOICE BETWEEN TWO UNSATISFACTORY PROPOSALS DENIED

A VIGOROUS argument was presented for the elimination of education from the Public Welfare Bill, based chiefly on the contention that education is of *primary* importance in a democracy, and secondarily on the ground that welfare is more logically considered a subdivision of education.

Congressman Fess, of Ohio, interrupted to propound what he called a very "practical question" which is facing the committee:

MR. FESS: Assuming that a separate department of education is not possible, would you prefer, speaking for the educators, to leave education where it is at the present time rather than to place it in a new department, as this bill proposes?

MR. MAGILL: I am not willing to assume that, because I am convinced that a department of edu-

cation is certain to come . . . but if I did assume that, I believe that education . . . will be worse off in the department of public welfare than it is today in the Department of the Interior.

This same question was asked of several witnesses who appeared before the committee, and they all took substantially the same position as that taken by Mr. Magill.

EDUCATORS SPEAK IN NO UNCERTAIN TONES

BEFORE introducing the witnesses who were present in person, Mr. Magill read telegrams which had been received from a large number of educators and others, protesting unanimously against the proposed "submerging" of education in a department of public welfare. I quote two of these messages, which are typical:

By Hon. Calvin N. Kendall, State Commissioner of Education, Trenton, N. J.: The proposal to merge the department of education with the department of general welfare is a monumental mistake so far as the interests of education are concerned. It will never work satisfactorily for the benefit of public education. School men of New Jersey are opposed to it. The country can afford to put public schools on a satisfactory basis. We had better not have this sort of legislation if the real purpose is to improve the status of education in this country.

By John R. Kirk, president, State Teachers College, Kirksville, Mo.: The bill for a department of public welfare in its present form would bring humiliation to every self-respecting man and woman in the teaching profession. It would subordinate education to layman control and political domination. It would discourage and depress all sincere and studious educational idealists. The present term, Commissioner of Education, at least carries definite meaning and commands respect, but the term assistant secretary of public welfare is vague and meaningless. Its apparent purpose is to produce confusion of ideals and belittle the efforts of American teachers. Education in our country needs freedom and professional initiative. It can never function effectively and with dignity until it is placed on a par with agriculture, commerce, and labor in a separate department.

The following persons were then presented, each one making a brief state-

ment and replying to questions from members of the comitee:

J. W. Crabtree, secretary, National Education Association, Washington, D. C.

Dr. William C. Bagley, Teachers College, Columbia University, New York City.

A. Lincoln Filene, chairman, National Committee for a Department of Education, Boston, Mass.

Mrs. Frederick P. Bagley, legislative representative, Republican State Committee, Boston, Mass.

Mrs. William Tilton, legislative representative, National Congress of Mothers and Parent-Teachers Association.

Lewis A. Wilson, president, National Society for Vocational Education, Albany, N. Y.

Dr. Samuel P. Capen, secretary, American Council on Education, Washington, D. C.

Dr. John Henry McCracken, chairman of the legislative committee, American Council on Education.

Dr. W. S. Athearn, chairman, Sunday School Council of Evangelical Denominations and International Sunday School Association.

H. D. Grose, secretary, Editorial Council of the Religious Press.

Dr. Robert L. Kelly, secretary, Council of Church Boards of Education, New York City.

Dr. William F. Willoughby, director, National Institute for Government Research, Washington, D. C.

THE LARGER PROBLEM OF ORGANIZATION INVOLVED

THE statement made by Dr. Willoughby was a plea for consideration of the question immediately before the committee in the light of its relation to the much larger problem of the reorganization of the executive branch of the federal government. Instead of discussing the desirability of creating a new department of public welfare, or a department of education, and what should be the component parts of such departments, the whole matter should be deferred until a comprehensive study can be made of the hundred or more separate services now in existence. This task has been specifically assigned to the Joint Congressional Commission on Reorganization of the Executive Departments. The studies of the Institute for Govern-

ment Research have proceeded far enough to suggest that it is possible to replace this multiplicity of services with a compact group of not to exceed eleven or twelve departments, doing away entirely with the so-called "independent" boards and commissions.

Dr. Willoughby and others have pointed out the possibility of reorganizing the government service on the basis of function. For example, the administration of substantive law is a function entirely distinct from that of research and investigation. Efficiency is promoted by recognizing each function and separating the service having it in charge from other non-related duties.

POPULAR UNDERSTANDING OF GOVERNMENT NECESSARILY LIMITED

The very size and complexity of the government service is a serious obstacle to its comprehension by any one. It is not always understood even by those who are employed to study it for the purpose of interpreting it to others. To illustrate: In the New York *Evening Post* for April 2d I read a story by Harold A. Littledale, the *Post's* Washington correspondent, under the headlines, "Survey of Government Shows Departments are Duplicating Activities and Wasting Millions," in which the following passage occurred:

How much the government needs reorganizing can best be indicated at the start, perhaps, by pointing out some of the absurdities that exist. . . . Now take cook books. In 1919 no less than 16 different cook books were issued by the government. The sixteenth was published by the Federal Board for Vocational Education, which is the agency commanded by law to rehabilitate disabled soldiers.

It is true, of course, that the Federal Board is charged by law with the rehabilitation of disabled soldiers, but it is wholly misleading to publish such a statement as that I have just quoted. When I saw Mr. Littledale a few days later,

and challenged the validity of this example of alleged absurdity, he admitted that he was a little "mixed" on this point.

Incidentally, I may say that I have heard responsible authorities who have given years of study to the various problems of administration in the federal government testify that charges of duplication of effort are largely groundless. Much can doubtless be accomplished by better organization of the government, but it will be chiefly in the direction of more effective service for the money expended, rather than in large economies due to elimination of duplications.

THE NEW COMMISSIONER OF EDUCATION

On Thursday, May 12th, many of us were startled by the announcement that the President had sent to the Senate the nomination of Professor John J. Tigert, to succeed Dr. Claxton as Commissioner of Education. The appointment was confirmed by the Senate on Tuesday, May 31st. The new Commissioner took the oath of office on June 1st, and assumed his duties at the Bureau of Education on Thursday, June 2d.

Mr. Tigert is a native of Tennessee,

graduated from Vanderbilt University in 1904, and was the first Rhodes Scholar from Tennessee, in Oxford, in 1907. From 1907 to 1909 he was professor of



International Film Service Co.

JOHN J. TIGERT

philosophy at Central College, Fayette, Mo. After serving two years as President of Kentucky Wesleyan College, he was appointed professor of philosophy at the University of Kentucky, at Lexington, which post he has held continuously since. —WILLIAM T. BAWDEN.

IN FOREIGN COUNTRIES

THE EASTER CONFERENCE OF MANUAL TRAINING TEACHERS

IN ENGLAND the Easter recess is the customary time for the annual conference of the National Association of Manual Training Teachers, also for the National Union of Teachers. This year the former met at Loughborough College, one of the younger institutions that has succeeded in "bringing a close co-ordination between technical studies and workshop practice, which was almost entirely lacking in the older types of technical colleges." Lord Burnham, one of the speakers at the Conference, compared its

growth to that of the fabled bean stalk. Before the war this College had "less than half a dozen machines and a staff of three"; now its staff numbers 173; it has about 350 machines; the attendance numbers 1400 day students and 1300 evening.

Altho the College itself was the major exhibit of the Conference, minor ones were sent from Leicester, Sheffield, Edinburgh and other centers of manual training work thruout the British Isles. The best brief report of the Conference that has come to our attention is the following taken from an editorial in the May issue of *Manual Training*:—

The Conference at Loughborough will be remembered as one of the most successful ever held. We had good meetings—the speeches were of a high order—a good exhibition, a capital dinner, and the arrangements made by the College authorities for the comfort of the delegates were excellent. But over and above this, there was the spirit of confidence, a rebirth of the faith—so sadly tested during past years—that has enabled us to meet annually for twenty years with a growing confidence in our work. That this confidence was justified few will gainsay. We have passed thru all the various stages incidental to the working out in practice of new ideas, but the sun of achievement has dispersed the clouds of prejudice and suspicion, and the whole of the garden in which we set out thirty years ago to cultivate a corner has been thrown open to us and we have been invited to help in tending it. This is due, as Mr. Stanley Jones pointed out, to the fact that manual training is so sound in its fundamentals that it has always fitted in with the developments in educational science. But we need take heed of Mr. Ivor John's oft repeated warning of danger of popularity. We have won recognition because of the clear vision and the soundness of the ideas of those who have advocated the value of manual training during the past thirty years. We have never wanted for leaders. Sir Philip Magnus, Sir John Cockburn, Sir William Mather are names we honor; but let us also pay tribute to the older workers in our Association whose work in the schools has been so earnest and convincing that it has led the Board of Education to suggest that the time devoted to manual training—practical subjects—should be extended to approximately half the school sessions.

Another impression one received at Conference—not only from the speeches made but from conversations with those competent to judge—was that much more value will be attached to the craft side of our work than has obtained during the past ten years. One gathered that teachers would be required to become more skilled, and that paper folding and a limited knowledge of clay, wood and other materials would not be considered sufficient for a teacher of practical subjects. The wide scope of the exhibition was a revelation in this respect. One saw on the one hand a wealth of ideas expressed in the various media but wherein the construction, in many cases, was bad; whilst, on the other hand, there was work exhibited where the construction was sound and pointed to a high degree of skill, and most of it was linked up with the school work, particularly in science. And the latter work came from the much despised centers. The distorted ideas of the work done in special

subjects centres, held by some people, is ludicrous, as any one knows who is intimate with what is being accomplished. And yet it is being repeated to-day. The question of craft teaching is well to the fore at Loughborough College, where the degree of skill attained is a very high one. The same high standard will be maintained in the new department it is proposed to set up for the training of teachers of practical subjects at the College.

As Major Brockington said in his speech at the public meeting: "His own opinion was that the finest teachers of handicraft in the schools had been themselves craftsmen, and he urged that they should set before themselves in the course of their training the practical ideals of the craftsman, and not rest with being merely contrivers, however skilful, of school exercises. (Hear, hear.) If the work of their classes was to be productive it could only be so by being brought into intimate relation with the rest of the work of the school. For that it was essential that the man who commenced as a teacher should really learn to be a craftsman, and that the man who commenced as a craftsman should school himself fundamentally in all other aspects of the work of the pupils committed to his charge."

A further fact that should be noted is the increasing number of young men of marked promise who are attending Conference. They display a sound knowledge of the essentials of our work and are imbued with a good deal of the old missionary spirit so necessary in any live movement.

"And so Conference ended on a high note of hope and determination."

OF the 30 hours per week during which boys attend the Junior Technical Schools of England, only six to eight are identified with the workshops, according to George Thompson, Headmaster of the Junior Day Technical School, Toxteth Technical Institute, Liverpool.

The remainder of the time is allocated to English literature, industrial history, elementary economics, geography, physics, chemistry, mechanics, mathematics, drawing, geometry, and organized games. It is plain, therefore, that the education provided is most liberal in character, and not confined . . . to the teaching of handicrafts The product of these schools is being more and more appreciated by parents, employers, and skilled artisans, and there is an ever-growing demand for the services of the aspiring young craftsmen which these schools aim at turning out.

PROJECTS, PROBLEMS AND NOTES

USE OF THE MICROSCOPE IN TEACHING TOOL SHARPENING

THE accompanying drawing is taken from a student's note-book record of one of a series of experiments which are part of a course in bench-work in wood.

Beginners in the use of tools so often grind an edged tool and, after a hasty whetting, attempt to use the edge before it is in perfect condition. It has been found that after a student examines a ground edge under the microscope (about 36 diameters

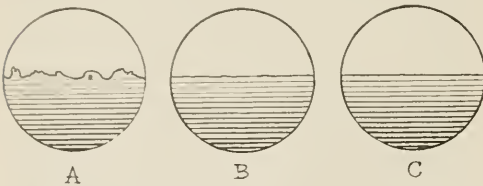

enlargement) that he realizes more fully the necessity for careful whetting. In the drawing referred to, A and B represent the edges of plane-irons prepared by students without knowledge of the experiment to be preformed. The blades were then examined under the microscope and the first two drawings made from the appearance of the edges in the microscope. A represents the edge as ground but not whetted. It plainly shows the "wire edge." B represents an edge that has been whetted on an oilstone. C represents edge B after more careful whetting and stropping. The necessity for careful whetting is closely shown by a comparison of A and C. One or more microscopes may be used according to the size of the class and equipment available.

—VICTOR J. SMITH,
Sul Ross State Normal College,
Alpine, Texas.

FORMULAS FOR OBTAINING THE COST OF LUMBER

THE formulas given below were received from H. H. Braucher, professor of manual arts at the State Normal School, Emporia, Kansas. In a recent letter referring to Densmore's Handy Lumber Table he says,

"I will be glad to have one of the tables as a bit of added information on the subject. However, I feel that formulas should be used instead, for the practical training they give in the application of mathematics—at least until the students have

thoroughly mastered the problem of board feet. I do not believe in so much pre-mastication for the pupils. It deprives them of things they need to know."

The formulas are these:

1. No. pcs $\times L' \times w' \times t'' = \text{bd. ft.} \times c = \text{cost.}$
2. No. pcs $\times L' \times \frac{w''}{12} \times t'' = \text{bd. ft.} \times c = \text{cost.}$
3. No. pcs $\times \frac{L''}{12} \times \frac{w''}{12} \times t'' = \text{bd. ft.} \times c = \text{cost.}$

Where L = length in feet or inches as indicated.

w = width in feet or inches as indicated.

t'' = thickness in inches.

c = cost per board foot.

Substitute and solve by cancellation.

WHY BELTS ARE STIFF

AN EXCELLENT way in which to make a study of belt fiber action is to take a pad of scratch paper, a magazine, or something of that sort; and bend it. It is easy to bend a pad of paper when the motion of the ends of the paper is unrestricted. You will note that one sheet slips along on the other a short distance. There is no tension on the convex side or compression on the concave side of the bent pad. Glue the ends together or hold the ends tightly with the hands, however, and it will be found more difficult to bend the pad. There will be a "buckling" on the concave side. The convex side will be in tension.

Glue the whole pad together by saturating it in glue and drying and you will have a chunk of material that will be as difficult to bend as cardboard, or even as difficult as wood. This is because buckling becomes impossible on the concave side if the gluing job is properly done. There is no sliding. There is a certain plane close to or at the center that is neither stretched nor compressed when the "board" is bent. That plane is called the "neutral axis." On the concave side of that axis the fibers of the board are in a compression. On the convex side the fibers are in tension.

The thicker the board the greater the force required to bend it. This is true because the fibers farthest away from the neutral axis have a longer lever arm than in a thinner board. And that is why steel I-beams, channels, Z-bars, etc., are made for engineering structures—to put the outside steel fibers as far away as practicable from the neutral axis.

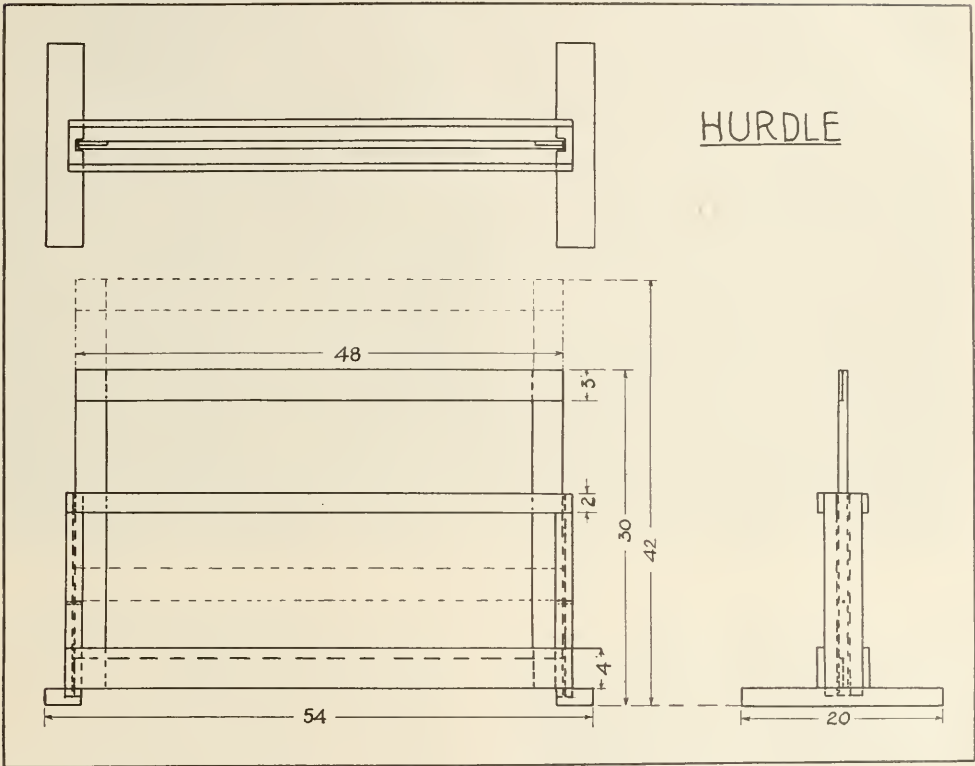

HURDLE

This explains why belts may be stiff or pliable. The dry, hard leather belt that is not lubricated in its fibers is naturally stiff because the fibers have difficulty in rubbing one over the other. Thus you will find it more difficult to bend a pad of sandpaper or emery paper, for example, than a pad of smooth writing paper. The dry, hard belt does not permit its fibers to slide on one another so easily on the tensile side nor on the compression side. The treated, lubricated belt, on the other hand, permits its fibers to slide with greater freedom. There is no "grinding" as in a pad of sandpaper.

This method of studying the belt will clear away many of the points that have been possibly troubling many belt users. It explains why double or three-ply belts are stiffer than single belts. It explains why treated belts are more pliable than untreated belts of the same thickness. It shows why lapped cement joints have a tendency to loosen or "shear" and why the cement used in any belt must be good.

I AM sending you a drawing of a hurdle we made last year. The athletic association did not have very much money, and needed low (30") and high (42") hurdles. The frame is made of 2-by-4 and the other pieces are 4-inch lumber. A frame was built of four pieces 3" wide and nailed together after cutting half-lap joints. The groove in the 2-by-4 is large enough to allow this frame to slide easily. This 2-by-4 is nailed to the other 2-by-4 after cutting the joint. These two ends are fastened together with a 4" piece at the bottom and a 2" piece at the top. With the frame down, the height should be 30", which is used for the low hurdles. By lifting the frame and placing a nail in the hole on each end, a height of 42" is obtained. This is for high hurdles.

They have been used for two seasons and found to be satisfactory and the expense of making them was low. We made five, but I had enough volunteers to make twenty-five.

—E. F. JUERGENS,
Middletown, Ohio.

Pick up a pad or a magazine and try it.

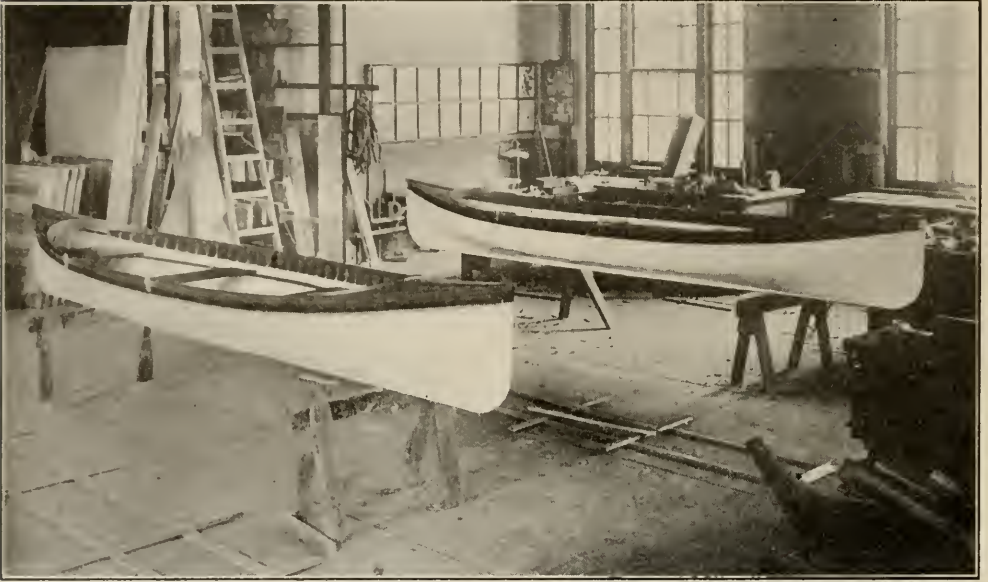

BOATS BEING FINISHED

A 16-FOOT ROW-BOAT

I AM submitting two photographs of two boats built in the cabinet shop of the Carnegie Institute of Technology during the summer quarter of 1920. It has occurred to me many times that there might be possibilities in the development of this type of manual arts work, in localities where water sports are popular.

The time to complete the project is, of course,

more than that required for most project in cabinet making. The two boats shown consumed approximately 200 hours for two people.

It is quite essential that two persons work on the same project, for most of the construction.

The design in this instance was furnished by the Brooks Co., of Saginaw, Mich., but was changed to some extent. The construction was of the ship-lap variety—no calking required. The material was

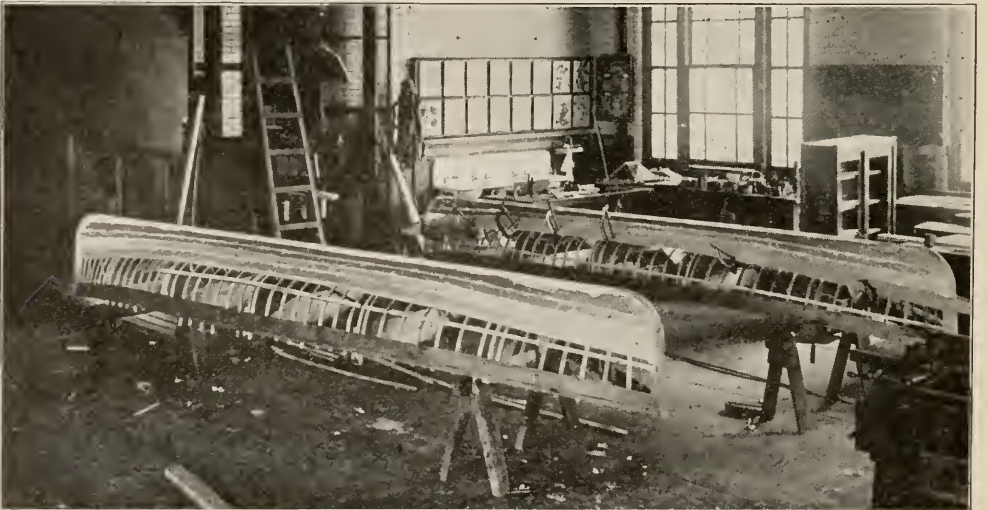

BOATS UNDER CONSTRUCTION



BUILT BY BOYS OF BIXBY, OKLAHOMA, HIGH SCHOOL. S. L. CALDWELL, DIRECTOR OF MANUAL ARTS.

oak for framework, best white pine for covering, and mahogany for seats and deck; copper nails and brass screws were used thruout.

Cypress, cedar, or redwood may be used for planking where obtainable. Various designs may be obtained from boat companies.

The various steps of this process of boat construction form an interesting study of themselves.

—E. H. SMITH,
Carnegie Institute of Technology,
Pittsburgh, Pa.

A CEDAR-LINED CHEST

THE making of a cedar chest is generally a problem of considerable interest in the technical or high school, as it is a much-desired article in the home because of its supposed efficiency in preventing moths from infesting winter clothing during the summer months.

Many people do not care for the appearance of red cedar when finished, the brilliant red of the heart wood in sharp contrast with the white of the sap wood, producing rather a startling effect; therefore, to gain the aromatic qualities of the cedar, and at the same time produce a more pleasing piece of furniture, chests have been constructed of various cabinet woods and lined with cedar.

The chest shown in the illustrations was designed and constructed in the Manual Training Department at Carnegie Institute of Technology. It illustrates how school shop problems may depart from the usual straight-line box effect. A simple form of the Queen Anne type was selected, and mahogany was the material used; walnut, gum, or poplar (to be enameled) would have suited the design equally well.

The work may all be accomplished in any shop having the usual equipment of rip-saw, band-saw, and planer; special machinery, such as the mortise-and-tenon machines and the shaper are very convenient.

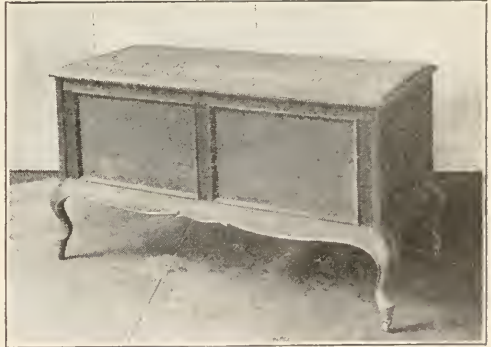

CEDAR-LINED CHEST, CLOSED

To obtain the curve of the foot, the material ($1\frac{1}{2}'' \times 1\frac{1}{2}''$) is blocked out on the two outside faces for a distance of $9\frac{3}{4}''$ from the bottom end. For this purpose, two pieces of material $9\frac{3}{4}'' \times 2\frac{3}{4}'' \times 1\frac{1}{4}''$ are necessary. These pieces should then be mitred on one edge and glued to adjoining faces of the leg.

The design is then drawn by ruling off the section $9\frac{3}{4}'' \times 2\frac{3}{4}''$ into $\frac{1}{4}''$ squares which will closely determine points in the curve. A templet may be cut and the curve transferred to the two outside faces of the post on the portion blocked out. After one side has been sawed out on the band-saw, the sawed-off portions may be tacked back in position by the use of small brads (thus preserving the lines),

and the remaining part of the design sawed out.

The moulding used, as well as the moulded edge of the top, was made with stock knives for the shaper; similar moulding, however, may be purchased at most lumber mills, and the moulded edge may be made by roughing out on the rip-saw and finishing with the plane.

The cedar lining should be made by re-sawing 1"



CEDAR-LINED CHEST, OPEN

cedar and gluing it up into sections wide enough to cover one side of the box—or the bottom, inside—and planed to about $\frac{3}{16}$ " or $\frac{1}{8}$ ".

There will be six (6) pieces, including the one on the inside of the cover. These pieces are fitted closely to the inside of the box and held in position with small screws—no glue being used for this.

Hinges are placed on the under side of the lid and the edge of the chest.

The bead on the lower edge of the chest and leg is worked on by hand.

The remainder of the design is practically self-explanatory.

—E. H. SMITH,
Carnegie Institute of Technology,
Pittsburgh, Pa.

A BORING JOB

Of peculiar ways of earning a living one of the oddest is reported by a New Orleans attorney.

A colored man was brought into court on some minor charge. The judge, following the usual routine, after asking his name, demanded:

"What is your occupation?"

"Well, sah, jedge, Ise a wormhole borer in an antique-furniture shop."

—SATURDAY EVENING POST.

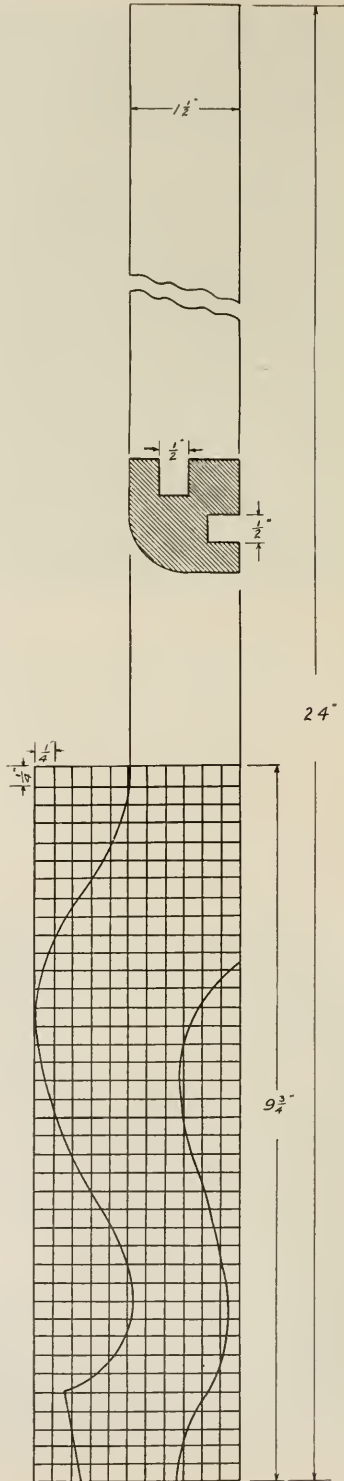

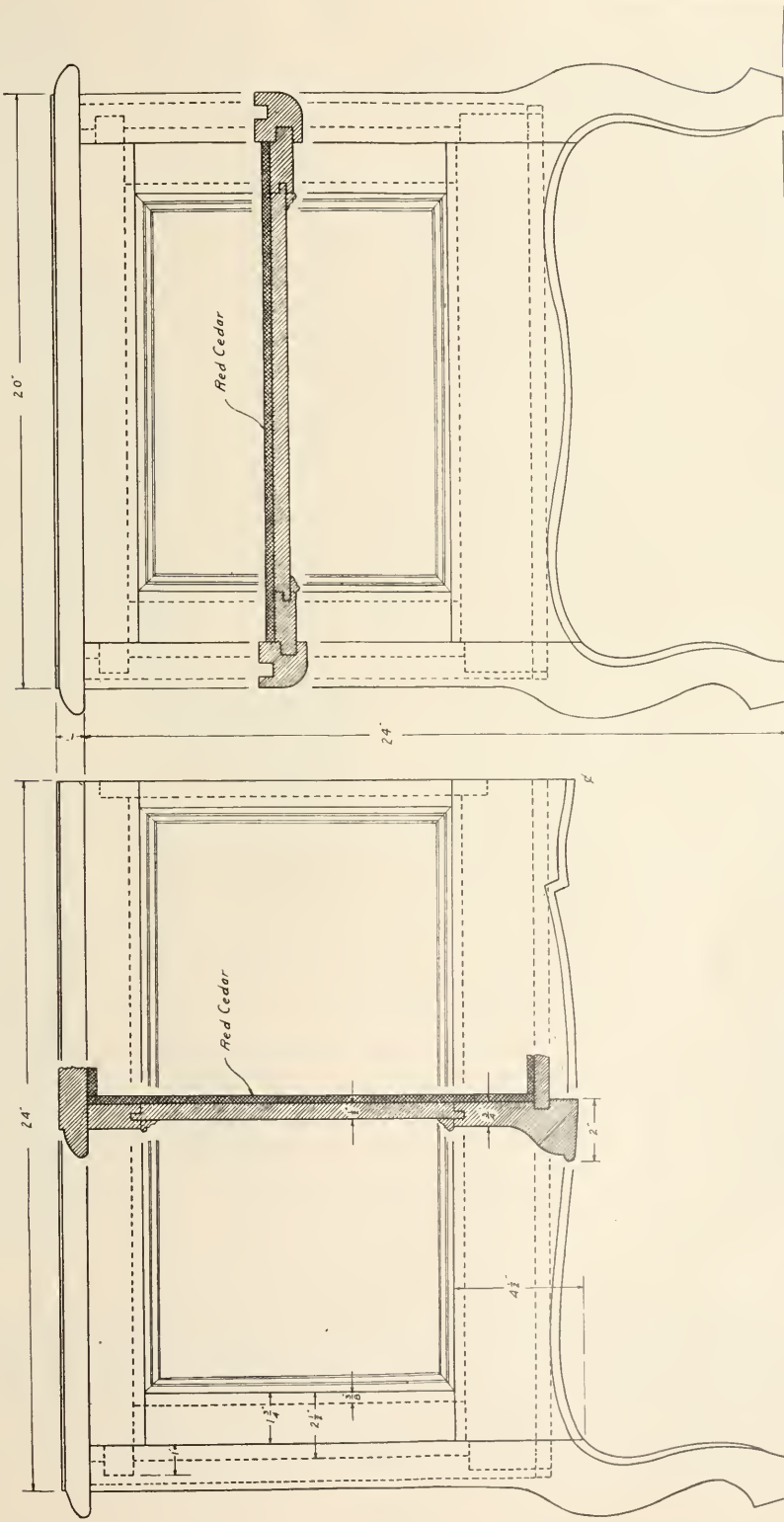

CEDAR-LINED CHEST

CURRENT PUBLICATIONS

RECEIVED

Problems in Elementary Woodworking. By Hugo J. P. Vitz, Head of Manual Training Department, State Normal College, Denton, Texas. The Southern Publishing Company, Dallas, Texas, 1920. Size 6½ x 8½ in., oblong; 126 pages; price, \$1.25.

This book is a course of instruction in two parts. Each part is made up of five groups, each of which emphasizes some principle of working or of construction. The first part is devoted to board structures, the second part to the simpler types of joints taught thru their application. The method of organizing the course allows for several problems in each group involving the same tools and processes. For example, there are 14 different sizes of chamfered boards in the first group and each is a different useful object when completed.

The author does not claim that the course is especially new in plan or problems, but it is evident to one who examines the book that great care has been exercised in adapting problems to the teaching conditions of the ordinary elementary woodworking shop.

Permodello Modeling. By Bonnie E. Snow and Hugo B. Froehlich. The Prang Co., 1920. Size 10 x 7½ in.; 42 pages, bound in heavy cover paper, many half-tone illustrations, one color plate; price, \$1.60 postpaid.

This is a teacher's handbook on the use of "Permodello," the permanent modeling clay. "Permodello" is a trade name given to a clay that has been chemically treated so that it hardens when exposed to the air, and becomes like porcelain without being subjected to intense heat. Moreover, it will take color as readily as paper or wood.

The book gives instructions and suggestive designs for beads, pendants, hatpin heads, La Vallieres, electric light pulls, paper weights, trays, candlesticks and a variety of other attractive school problems.

Descriptive Geometry Problems. By F. G. Higbee, University of Iowa. John Wiley & Sons, New York, 1921. Size 9 x 12 in., oblong, loose-leaf; 218 problems on 77 plates; price, \$1.50.

This book is a time-saving device for teaching descriptive geometry. The plates are to be taken out of the book and tacked to the drawing board as needed. On each plate is one or more problems which are intended to be solved on the piece of paper on which they are printed.

The author states that it is not expected that these problems alone will constitute a course in descriptive geometry, but that they will provide the experience needed by students to master the fundamental principles of the subject. They may be used with and as a supplement to any standard textbook on the subject.

The Value of Manual Training in the Education of the Boy. By R. C. Huntington, Greenville, Wisconsin.

Our Needs and Opportunities in the Industrial Arts. By James Parton Haney. An address delivered at the Philadelphia School of Design for Women.

Industrial Rehabilitation—General Administration and Case Procedure. Bulletin No. 64. Issued by the Federal Board for Vocational Education.

Concrete School Houses. An illustrated bulletin sent out by the Portland Cement Association, Chicago, Ill.

The Application Blank for Enrollment in Part-Time Schools. A statistical study by Emily G. Palmer. Part-Time News Notes No. 4. Issued by the University of California, Berkeley, Calif.

Junior Employees in the Retail Drug Business. By H. A. Campion. Part-time News Notes No. 5. Issued by the University of California, Berkeley, Calif.

Prospectus of the Technical Industrial School, San National Society for Vocational Education. By C. W. Middleton, Secretary, Lewis and Clark High School, Spokane, Wash.

Prospectus of the Technical Industrial School, San Juan, Porto Rico. An illustrated pamphlet giving the history and aim of the school and outlines of the courses of instruction. Herman Hjorth, director of technical work.

Program of Studies and Curriculum Organization, Junior High Schools, Cleveland, Ohio. A pamphlet issued by the Board of Education.

Vocational Education in the Pulp and Paper Industry. By J. C. Wright. Published by the Joint Executive Committee of the Vocational Educational Committee of the Pulp and Paper Industry.

"Z-Ninth" Long Distance Radio Apparatus. Bulletin of the Chicago Radio Laboratory, 6433 Ravenswood Ave., Chicago, Ill.

Bulletin of the School of Fine Arts, University of Pennsylvania. This describes a course leading to the degree of Bachelor of Fine Arts.

1921 Tech. This is the annual published by the students of the Robideaux Polytechnic High School, St. Joseph, Mo. It was printed by the students in the printing department of the school and is a very commendable piece of work.

The Wichitan. The student annual of the Wichita High School, Wichita, Kansas. Printed by the Wichita High School press.

Saves Time and Trouble in Tight Quarters

The "Yankee" Ratchet Hand Drill No. 1530 has five adjustments, changed at a finger-touch on ratchet shifter between the small gears; Plain Drill; Left-hand Ratchet; Right-hand Ratchet; DOUBLE Ratchet. In the fifth position, the gears are locked for changing the drill.

In a cramped place where you cannot turn the crank, shift to DOUBLE Ratchet and move crank back and forth. Every move, no matter how slight, causes the drill to cut. "Yankee" Drills *only* can do this, for they are the only drills with the "Yankee" Ratchet.

The "Yankee" No. 1530 (for drilling small holes) is built along the same mechanical lines as the big "Yankee" Ratchet Hand Drills and Breast Drills.

Only 10½ inches long. Weight 1¼ pounds. Has three-jaw chuck for round drills only, up to 3/16 inches.

Dealers everywhere sell "Yankee" Tools.

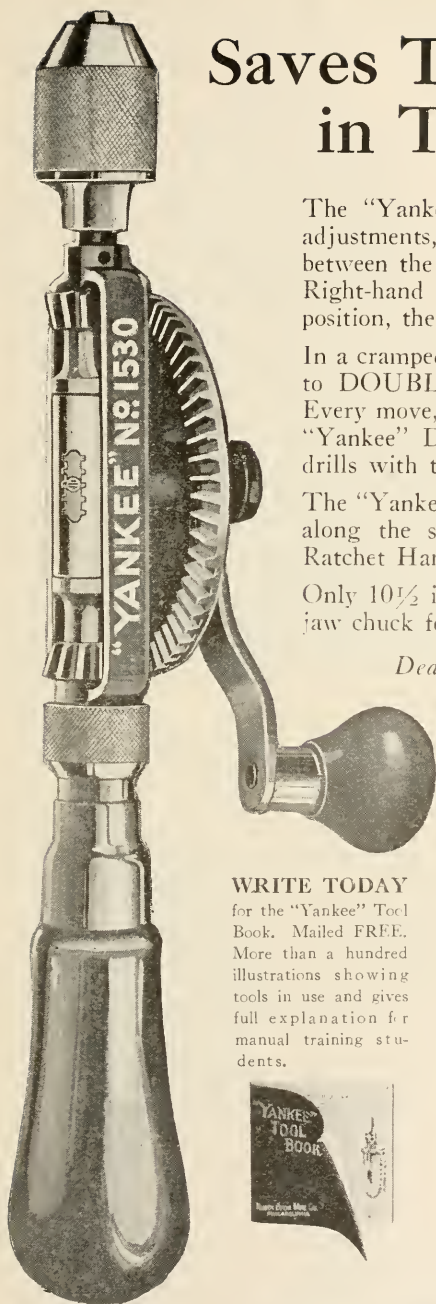

WRITE TODAY
for the "Yankee" Tool Book. Mailed FREE. More than a hundred illustrations showing tools in use and gives full explanation for manual training students.



Some other "Yankee" Tools

Spiral Screw-drivers
Ratchet Screw-drivers
Plain Screw-drivers,
 1½ to 30 in. blades
Ratchet Breast Drills
Ratchet Chain Drills
Ratchet Bench Drills
Automatic Push Drills
Ratchet Tap Wrenches
Bench Vises, Removable
 Swivel Base

"YANKEE" Plain Screw-drivers

With blades that never loosen or turn in the sockets. Blades of specially made steel.

No. 90 Standard Style.
 Blades, 1½ in. to 30 in.
No. 95 Cabinet Style,
 Blades, 2½ in. to 15½ in.



NORTH BROS. MFG. Co., Philadelphia

"YANKEE" TOOLS

Make Better mechanics



FIELD NOTES—(Continued)

"Next in order of surprises is the amazing number of men already well versed in the subject chosen, who come to perfect themselves. Innumerable auto-mechanics are registered in the classes in ignition and other work connected with the modern car, to learn the subject down to the last detail.

"While the average age of the student with us is twenty-five, it is surprising how large a percent are well-to-do, and come to the school for the pure love of learning."

The school does not operate placement bureaus; but its graduates need have little fear on that score. Employers of every kind are coming to know that the school—and other K. C. schools like it—are turning out every year the best sort of material. The employer is coming to the school-room to find the expert he wants. Nor is he apt to be disappointed.

The keynote of each K. C. course is absolute dependability, and men employing graduates of the school know that men can be depended upon for efficiency and reliability.

—FELIX J. KOCH.

WORK DONE BY STUDENTS

AT THIS season of the year a great deal of information is available concerning "productive work" that has been done in various types of schools. For example, today we have a photograph of a very pleasing two-room school building which was made by students in the manual arts department of the Polytechnic High School and Junior College, Riverside, California, under the direction of J. Douglas Wilson.

A newspaper illustration shows a large pile of folding chairs, 100 in all, made by boys 10 to 14 years of age, at the Liberty Manual Training School, Rochester, N. Y. These chairs, which are for use in the school auditorium were made under the direction of Luther W. Richards and Ralph W. Emerson.

Another newspaper tells about work done at the technical high school in Springfield, Mass., in constructing the scenery for school plays. The wood-work class has made four pilasters 15 feet high. A set of steps, a platform and a drop for the curtain have also been made.

TO TEACH THE TRADE OF OFFICE BOY

NEW dignity will soon be taken on by the office boys of Norfolk, Va., if the business men and the boys' club of that city carry out their present plans "to teach the trade of office boy." According to a newspaper account it is proposed that the



**GOOD TOOLS
ARE ESSENTIAL FOR
GOOD WORK**

Since 1848 we have adhered to one policy—to handle only the very best in quality.

Our 300 page catalog illustrated above is of particular value to those interested in manual or vocational training. If you haven't a copy ask for Catalog No. 224.

**HAMMACHER
SCHLEMMER & CO.**
Hardware, Tools and Supplies
New York, Since 1848, 4th Ave. and 13th St.



THE VERY BEST

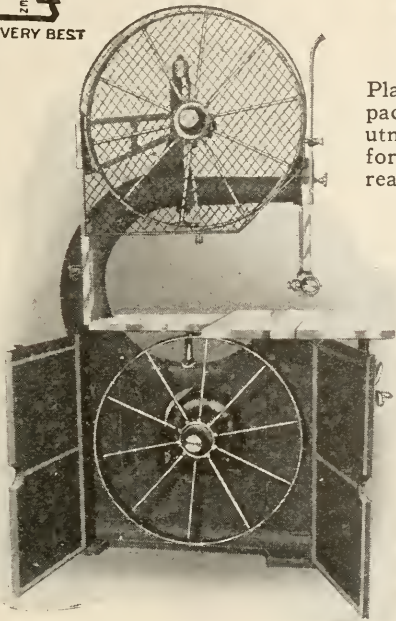

West Side

Plain, symmetric, a model of concise, compact design, a West Side band saw offers utmost capacity for good work. A machine for every purpose, each possessing very real advantages.

We would particularly direct attention to the uncommon strength of our band saws. They are of liberal proportions where the strain comes.

A New Motor Driven 36" Band Saw

—shown to the left. Most convenient of all to use. Its every adjustment is reached without change of position for the operator. Write us for information. Direct motor drives —belt drives—gear drives.

WEST SIDE IRON WORKS

Factory: Grand Rapids

General Offices:

1222 Washington Blvd., Chicago

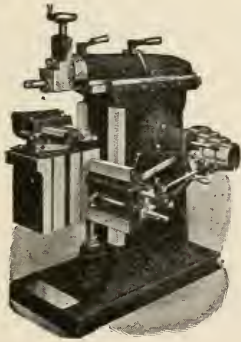

Steptoe SHAPERS and MILLERS

Steptoe Shapers and Millers are used in a large number of school shops because they are easy to operate and practically fool proof.

Send for our catalogue and learn more about the machines built by a firm with 75 years of experience in the manufacture of high grade tools.

**THE
JOHN STEPTOE
COMPANY**

Industrial Education
Department
CINCINNATI, OHIO

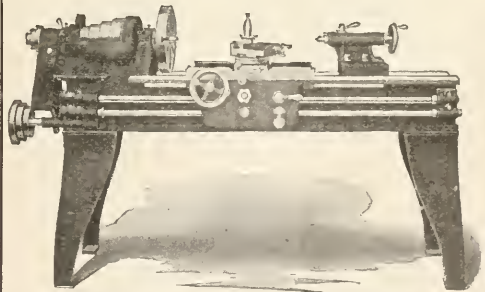
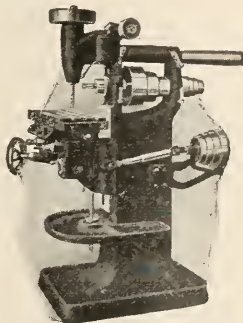

**COMPLICATED MACHINERY
is not adapted for school work**

STANDARD ENGINE LATHES

are of simple design, combining accuracy with the highest quality of workmanship and materials.

Send for descriptive matter of this medium price machine which has been especially designed for school work.

"QUALITY WITHOUT FRILLS"
Sizes 14"—16"—18"—20"

THE STANDARD LATHE WORKS
2951-61 Colerain Ave. CINCINNATI, OHIO

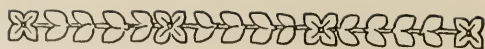

FIELD NOTES—(Continued)

first lessons cover one week and consist in wrapping bundles and addressing them. A large retail store has agreed to furnish the instruction in this class. Lesson 2 will consist of receiving visitors and running errands. In lesson 3, postal work will be taught. Telephone courtesy will be lesson 4, card filing is included in lesson 5, while lesson 6 consists of elementary instruction in banking.

Every one of these classes, when the system is finally inaugurated, will be provided for in some Norfolk business house. Certificates will be issued at the completion of the course, and if the student is found to be proficient he will be recommended whenever an opportunity for employment offers itself.

THE GENERAL EDUCATION BOARD has appropriated \$60,000 to provide for an investigation of classical education in the secondary schools of the United States. The investigation will be conducted by the American Classical League, and will probably require three years for its completion. It will be in the general charge of an advisory committee of which Dr. Andrew F. West of Princeton University will be chairman.

A SPECIAL CONFERENCE of industrial arts teachers, industrial teachers in part-time schools, industrial teachers in general industrial, unit trade, and evening vocational schools was called at the State Normal School, Oswego, N. Y., by L. A. Wilson, the state director of vocational education for May 13th. Teachers were present from central and northern New York. Joseph C. Park of the Normal School was the chairman. Among the items on the program were addresses by Lewis A. Wilson, Leon L. Winslow, Robert H. Rodgers, Oakley Finney, W. C. Smith and Eugene D. Fink, all of the State Education Department, and Verne A. Bird of Utica and Donald M. Kidd of Syracuse.



Boyle Heights School,
Los Angeles, Calif.

Standard School Equipment

The Boyle Heights School uses our patented down draft forges, which give excellent results.

This forge returns the unconsumed gases for complete combustion. Recommended particularly for schools where gases and fumes must be removed because they frequently injure the students' health.

Send for catalog 205-31 which contains notes on forge shop practice and modern equipment for schools of mechanical technology, etc.

Buffalo Forge Company

BUFFALO, N. Y.

“Buffalo”

“JORGENSEN”

**Peerless Hand Screws
are Adjustable**

Think what that means in widening their range of usefulness.

Steel Spindles
Steel Nuts
Hard Maple Jaws

**Adjustable
Clamp Co.**

216 N. Jefferson St., Chicago

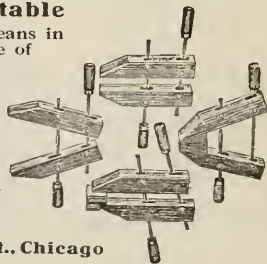

TURNED FROM BEAUTIFUL BLACK WALNUT



A SET OF PATTERNS AT COST

SQUARE BLANKS, selected and sawn to develop the "figure" either in "curly" or Circassian, for dresser or Vanity Cases, can now be had in sets of four or multiples of same at the same prices as for lots of one dozen.

Delivered Free in the U. S. A.

Write for List 46

Manufactured by **FRANK R. PORTER** WASHINGTON, D. C.

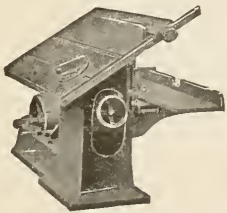

Crescent Wood Working Machines

are the tools your students will eventually use so give them the opportunity now of learning about this splendid line of wood working machinery.

Send today for our catalog of band saws, jointers, saw table, shapers, variety wood workers, planers, planers and matchers, cut off saws, disk grinders, borers, hollow chisel mortisers, Universal wood workers.

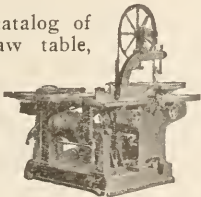

The Crescent Machine Co.

46 CHERRY ST. LEETONIA, OHIO

SIMPLIFY GRINDING

With Mummert-Dixon Oilstone Grinders. Five wheels for almost every class of grinding. They accomplish the work quickly and accurately. With this machine your students can experience the pleasure of sharp tools.



The Modern
Edge Tool
Sharpening
Machines.

The
Standard
for all
Industrial
Schools

Five
Leading
Features
Coarse Oilstone
Wheel
Fine Oilstone
Wheel
Emery Wheel
Grinder
Cone
Leather
Wheel

Furnished for motor drive or with counter-shaft
Send for full descriptive bulletin
MUMMERT-DIXON CO., Hanover, Pa.

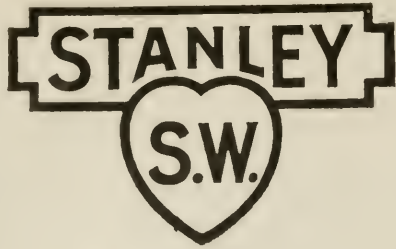

Gage Self-Setting Iron Plane

Stanley Carpenters' Tools are used in most manual training schools because they have proved themselves most dependable. Write for a catalog and get acquainted with the complete line.

The plane iron, when removed to be honed or sharpened, is replaced in exactly the same position as before removing. This also applies to the plane cap; when taken out to allow removal of the cutter, it goes back in the same position.

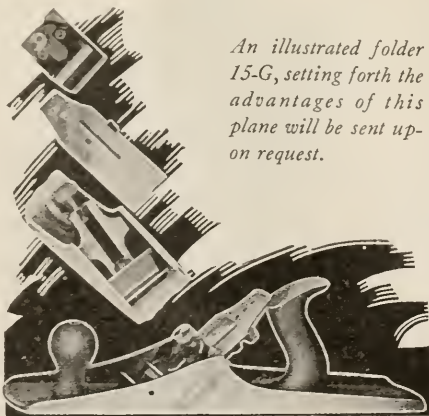

An illustrated folder 15-G, setting forth the advantages of this plane will be sent upon request.

THE STANLEY RULE & LEVEL PLANT.
THE STANLEY WORKS
NEW BRITAIN, CONN. U.S.A.

CABINET CLAMPS



Where Black Bros. Clamps are known there is no Second Choice.

KNOW THEM

Send for bulletin today.

THE BLACK BROS. CO.
Mendota, Ill.

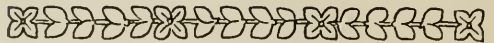

FIELD NOTES—(Continued)

IN CLEVELAND the students from the fifth and sixth grades of certain schools are taken to the Art Museum where under a special art teacher they are shown the manner in which animal forms are conventionalized and used as decorative motifs for armor, textiles, carvings, etc. or they are taught to recognize what forms are best adapted to the potter's art. This ought to be a suggestion to manual arts teachers in the higher grades of cities where museums are available.

AT THE ANNUAL MEETING of the School Crafts Club of New York City, the following officers were elected for the year 1921-1922:

President, Martin J. Corcoran, supervisor of manual training, Elizabeth, N. J.; vice president, Philip M. Wagner, teacher of manual training, Cleveland Junior High School and secretary of the Industrial Junior High School and secretary of the Fawcett School of Industrial Arts, Newark, N. J.; secretary, Frederick C. Arnold, teacher of mechanic Arts, New York City; treasurer, Edwin F. Judd, instructor of machine shop practice and art metal work, high school, Montclair, N. J.

The members of the program committee are John M. Dockstader, Allen D. Backus, and Albert N. Petterson; of the membership committee, Robert A. Campbell, Byron G. Dreifoos, and Samuel Tanenbaum; of the publicity committee, Russell F. Hemion, Richard O. Reger, and George L. Dobbelaar.

TOOLS

For Manual Training Shops.
Send your inquiries to and get the especially low prices quoted by

MONTGOMERY & CO. Inc.,
105 Fulton Street New York City



Who can name the limits of the inspiration of the right drawing materials in the hands of your pupils?

Often the difference in tools is all the difference between failure and success.

Put your pencil drawing on the right road with

DIXON'S ELDORADO

"the master drawing pencil"

SAMPLE OFFER TO TEACHERS

Dixon's Eldorado is made in 17 leads. Tell us whether you teach mechanical or freehand drawing and we will mail you suitable samples.

Joseph Dixon Crucible Company

Pencil Dept. 19-J Jersey City, N. J.



Improved Drawing Instruments

We are again supplying our College and School Styles of Drawing Instruments. With improvements we have been able to make in the design and construction these set an advanced standard for instruments of precision designed for classroom use.

Attractive Prices

Send us your list of requirements for your next term classes. If you contemplate any change in address also, let us know. We wish to keep your name and address correctly.

The Frederick Post Company

DRAWING MATERIALS
Irving Park CHICAGO, ILL.

Specialists in Manual Training Lumber

Maisey & Dion

Hardwoods

KILN DRIED AND AIR DRIED

OFFICE & YARDS 2349 to 2423 So. Loomis St.

TELEPHONES

CANAL 1830

CANAL 1831

CANAL 118

CHICAGO
THE
Great Central Market

Pattern Making

By
EDWARD M. McCracken

*Head of Woodworking Department
Johnson School, Scranton, Pa.*

and
CHARLES H. SAMPSON, B. S.

*Head of Technical Department, Huntington School,
Boston, Mass.*

Author: "Mechanical Drawing and Practical Drafting"; "Woodworking Exercises, Algebra Review"; Instructor, Correspondence Department, Massachusetts Department of Education.

A text for technical, trade and vocational schools, presenting a practical course in pattern making which aims to give students such a knowledge of the principles as to enable them to make patterns of any usual type. The treatment of the subject is intended to maintain the interest and industry of the student, in that each pattern illustrates a definite principle. There is also such information on tools, machinery, and woods as the student who expects to become a first class mechanic needs.

120 Pages 10 $\frac{3}{4}$ x 8 Inches Cloth \$2.00
30 Plates 84 Text Illustrations

Motor Vehicles and Their Engines

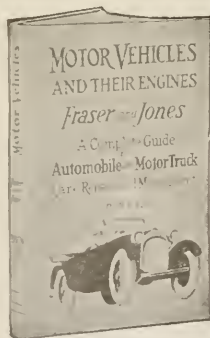

By
EDWARD S. FRASER

American Bosch Magneto Corporation; Formerly Captain C. A., U. S. A., Instructor Motor Transportation Course, Coast Artillery School.

and

RALPH B. JONES

Formerly Captain C. A., U. S. A., Instructor Motor Transportation Course, Coast Artillery School.

A complete book on the automobile written in the simplest language and with technicalities reduced to a minimum.

The fundamentals of gas motor operation, as well as the care and operation of the principal accessories of motor vehicles are discussed in detail and at greater length than usual.

350 Pages. 6 x 9 inches. Flexible fabrikoid. \$2.00
278 pictures, many in colors

D. Van Nostrand Company

PUBLISHERS AND BOOKSELLERS

8 Warren Street

New York

Marqueterie, Inlay Borders and Purflings for

Manufacturers and Vocational
Schools

Insets for Trays, Panels, Cabinets, etc. carried in stock.
Natural and Transformed Veneers in great variety.
Lines in Holly, Satinwood, Box, Mahogany and Black

J. BERNARD CO.

422 to 30 East 53rd St. New York

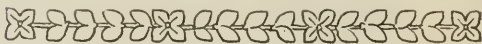

FIELD NOTES—(Continued)

GRAND RAPIDS, MICH., is planning a new junior high school in which provision is being made for the following industrial work for boys: Printing, sheet-metal work, automobile repairing, wood-working, machine and forge shop work, electrical work and mechanical drawing.

OMAHA, NEBRASKA, is planning a \$2,000,000 high school which will include shops for auto mechanics, electrical work, carpentry and blacksmithing and rooms for mechanical drawing. It is expected that it will be possible to build a five-room cottage in this building and then take it out and place it on an appropriate foundation.

SYRACUSE, N. Y., is planning a junior high school which will contain the following shops: bench wood-working, machine woodworking, sheet-metal, electrical, printing, and machine.

THE FOREST PRODUCTS LABORATORY of Madison, Wis., has just announced three courses in boxing and crating: The first is from July 25 to 30, the second from Sept. 26 to Oct. 1, and the third from Nov. 7 to 12.

Build Your Own PHONOGRAPH

Instructive—arouses pupils enthusiasm—provides one of the best problems in cabinet making.

Let Your Pupils Build
Choraleon Phonographs

We furnish, plans, blue prints, motors, tone arms, case material—in fact, everything required. Full instructions. Choraleon's have fine tone. Play any record. Ask for particulars.



CHORALEON PHONOGRAPH CO.
721 7th St., Elkhart Ind.



Vaughan's Supersteel Braces

MADE OF VANADIUM

In vocational and industrial art training concentration upon quality of tools is important. V & B Tools are made of the best alloy obtainable, insuring high quality.

Vaughan & Bushnell Mfg. Co.

2114-2138 Carroll Ave. Chicago

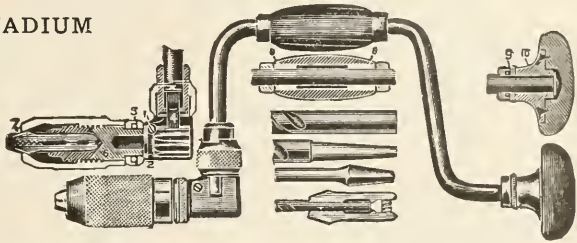

Vaughan's No. 222 Brace, 8, 10, 12, 14 inch sweeps.

SAW TABLES

For MANUAL TRAINING

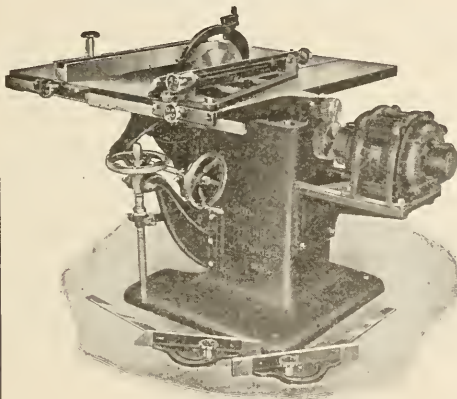

This cut shows our motor driven spiral gear saw table. No countershaft, no belts. Filting or stationary tops. Write for circular and prices on our entire line. Address

ALEXANDER DODDS CO.

451-453 Monroe Ave., N.W.

GRAND RAPIDS, MICHIGAN, U. S. A.

ELGIN JUNIOR BAND SAW

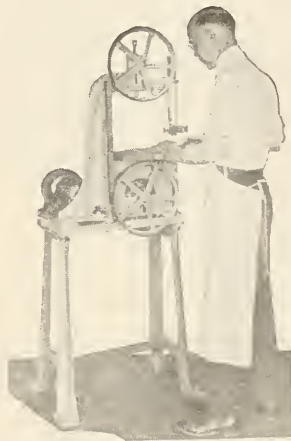

A Portable Bench Band Saw

For Wood or Soft Metal. Easy to Carry. Comes equipped with motor, wire switch, light plug and safety guards.

15 days free trial anywhere in U. S. A.

THE ELRICK MFG. CO.
ELGIN, ILLINOIS

Tools for Sheet Metal Work

Manual training, vocational and technical schools are invited to communicate with us regarding equipment of shops for sheet metal work, the importance of which is constantly increasing, owing to the popularity of sheet metal as a substitute for other materials.

Ask for catalog M T 56.

NIAGARA MACHINE AND TOOL WORKS
BUFFALO, N. Y.

Manufacturers of
MACHINERY FOR WORKING SHEET METALS

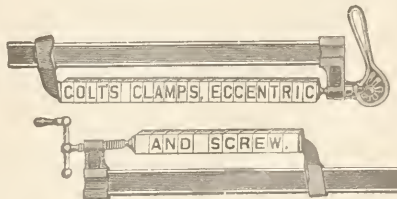

Forty styles of Quick Acting Clamps for the Worker in Wood, Cement and in the trades generally.

Your dealer will supply you.
Ask for catalog No. 296.

BATAVIA CLAMP CO.

237 Center Street

BATAVIA, N. Y.

Books for Summer Study

Advance Yourself during
Vacation by Reading
these Valuable Books

- HANDWORK IN WOOD...** *Noyes*
The best reference book available for teachers of woodworking. 3.00
- WOOD AND FOREST...** *Noyes*
A comprehensive treatment of sixty-seven species of wood. 4.00
- DESIGN AND CONSTRUCTION IN WOOD...** *Noyes*
The esthetic as well as the practical side of woodworking. Will help you do the same thing better. 2.50
- THE MANUAL ARTS...** *Bennett*
Selection, organization and methods of teaching. 1.20
- HANDWORK INSTRUCTION FOR BOYS...** *Pabst*
Philosophical and historical review of manual training. 1.50
- FURNITURE UPHOLSTERY FOR SCHOOLS...** *Johnson*
Detailed, practical instruction telling how to upholster new and how to re-upholster old furniture. . . 1.25
- CARPENTRY...** *Griffith*
Complete textbook on frame house construction. 1.70
- WOODWORK FOR SECONDARY SCHOOLS...** *Griffith*
A comprehensive and complete textbook on woodworking for advanced high school students. 2.64
- WOOD PATTERN MAKING...** *Purfield*
Fundamental principles of pattern-making. 2.16

Correspondence Invited

THE MANUAL ARTS PRESS

PEORIA, ILLINOIS

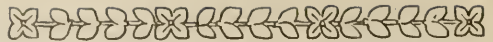

TRADE NOTES

AT THIS time of the year, when teachers are interested in equipment, they will be glad to know of a new publication, describing the Christiansen line. The catalog No. 27, is issued by C. Christiansen, 2814 W. 26th St., Chicago. It illustrates and describes in a very attractive and complete form a line of manual training benches, including various designs, also vises, clamps, domestic science tables, cabinets, drawing tables, etc. Teachers interested in equipment will find this catalog helpful since it contains many worthwhile suggestions.

STANDARD ENGINE LATHES

THE "STANDARD" ENGINE LATHE has been placed on the market to meet the demand for a machine without expensive quick-change arrangements. The manufacturers say that they have succeeded in producing a machine that can be depended upon for high production with accuracy and durability—a tool of high quality at a moderate price. It is a machine of "quality without frills" which they claim is ideally suited for school shops, being devoid of intricate parts.

Information regarding these lathes will be gladly furnished to readers who are interested in the purchase of a lathe if they will address the manufacturers, The Standard Lathe Works, 2951-2961 Colerain Ave., Cincinnati, Ohio.

CABINET CLAMPS

HOW ARE YOUR CLAMPS? For successful work good clamps are so necessary, and all too often are either poorly made or in bad repair. An inspection of clamp equipment should be taken at intervals. The Black Bros. Co. are manufacturers of clamps of known quality, made to do their work well and to last long. During the war Black Bros. clamps were purchased in large quantities by the

**MITER
SAW
BENCHES**

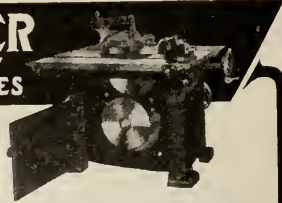

The "Tannewitz" Universal Double Revolving Arbor Saw Bench with Sliding Table and Taper Pin Gauges is the only logical tool for the wood shop where frequent setting up is the rule and accuracy is the goal. Send for bulletin.

THE TANNEWITZ WORKS
GRAND RAPIDS, MICH

MAYDOLE HAMMERS



Adze Eye
Nail Hammer



Machinists'
Hammer



Blacksmiths'
Hammer



Copperworkers'
Hammer



Adze Eye
B. F. Hammer

JUST A FEW OF OUR HAMMERS

All our Hammers are forged of Crucible Tool Steel—tempered by hand.

Booklets containing a story of David Maydole's life and mechanical data for the boys will be sent on request

THE DAVID MAYDOLE HAMMER CO.

NORWICH, N. Y.

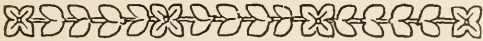

TRADE NOTES—(Continued)

Government and they are now offering their quality goods to the schools. Their address is The Black Bros. Co., Mendota, Illinois.

TEACHERS CONFRONTING PROBLEMS involving inlay, marquetry, etc., will be pleased to learn of a firm making a specialty of this kind of work. J. Bernard Co. carry in stock insets for trays, panels, cabinets, etc., lines in holly, satinwood, box, mahogany and black and can be depended upon to furnish high-grade goods with the skill acquired thru many years in the business. Their address is J. Bernard Co., 422 to 430 East 53rd Street, New York, N. Y.

MANUAL TRAINING TEACHERS who practice a little "household mechanics" during the summer vacation may be glad to get the 25ct. book on "The Proper Treatment of Floors, Woodwork and Furniture" issued by S. C. Johnson & Son, Dept. M. T. 5, Racine, Wis. This book tells how to get the very best results with Johnson's famous finishes.

AMERICAN

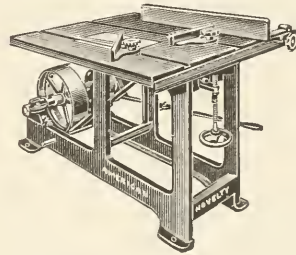

Novelty Saw Table

One of Several Types of Machines
Suitable for School or Shop

Also

BAND SAWS, PLANERS, JOINTERS,
VARIETY WOODWORKERS,
LATHES

High Grade Machines for Manual
Training Schools at Moderate
Prices

AMERICAN SAW MILL MACHINERY CO.

142 Main St., Hackettstown, N. J.



MINUSA

(Trade Mark)

DRAWING INSTRUMENTS

MADE IN U. S. A.

Modern American methods of quantity production have enabled us to place on the market this line of drawing instruments (which possess a high degree of excellence) at a price within the reach of the Manual Training Student.

PERFECT SATISFACTION AT MODERATE COST

Price list sent on application.

KEUFFEL & ESSER CO., HOBOKEN, N. J.



CLASSIFIED ADVERTISEMENTS



Do you want to sell or want to buy some school shop supplies? Do you want to employ a teacher? Do you want a new position? Advertise your wants in these classified columns. Rate 20c a line, minimum \$1.00.

ELECTRICAL PROJECTS

BUILD "PEPCO" ELECTRIC TOASTERS—A useful and attractive project. Buy the parts from the Practical Electrical Projects Co., Highland Park, Illinois.

UPHOLSTERY MATERIALS

UPHOLSTERY SUPPLIES FOR MANUAL TRAINING—We carry most things needed in the manual training departments such as, tools, imitation and genuine leathers, and upholstering supplies. Tray handles, catches and knobs, casters, mirrors, etc. Write for our Catalog. F. A. Rauch & Co., 410 So. Market St., Chicago, Ill.

CUSHIONS—You know your cushions will be made right when furnished by the Grand Rapids Cushion Company. Write for estimates on cushions and all kinds of upholstery supplies. Grand Rapids Cushion Company, Grand Rapids, Michigan.

MANUAL TRAINING LUMBER

FRANK PAXTON LUMBER CO., KANSAS CITY, KANSAS—We have for immediate shipment in any quantity: Plain and Quartered Oak, Red and Sap Gum, Walnut, Curley Redwood, Tennessee Red Cedar, Ash, Mahogany, Jenizero, Spanish Cedar, Redwood, White Pine, Poplar, Cypress, Maple, Sycamore, Holly, Beech and Magnolia. Write for price list and particulars.

AMERICAN WALNUT LUMBER—We carry a stock of over two million feet of Walnut Lumber, consisting of all grades and thicknesses from 1/2" to 4". Due to this large stock we are always in position to supply dry lumber for Manual Training use. Send us your inquiries. Frank Purcell Walnut Lumber Company, 12th Street & Belt Line, Kansas City, Kansas.

AROMATIC TENN. RED CEDAR BOARDS. Small shipments a specialty. Write us for prices delivered at your railroad station. Earthman Lumber Co., Murfreesboro, Tenn.

MORGAN MANUAL TRAINING MATERIALS—A perfect system of dry kiln enables us to give you lumber thoroughly dry. Carrying in stock large quantities of different woods permits us to fill your orders with the best selections. Write, sending us a list of the materials you desire. We will quote you attractive prices. Morgan Company, Oshkosh, Wisconsin.

LUMBER—Maisey & Dion, 2349 to 2423 South Loomis St., Chicago, Illinois, carry in stock a large and diversified stock of **MANUAL TRAINING LUMBER.** Fifteen years' experience with schools enables us to fill such orders satisfactorily.

SCHOOL SHOP SUPPLIES

SODERING SUPPLIES, including the famous Allen Non-Acid Sodering Fluxes—in stick, paste, salts and liquid form; handy soder sets, sodering tools, aluminum soder and flux. As pioneers in the development of fluxes that far surpass muriatic acid, in every way, and as the original exponents of non-acid fluxes, the House of Allen has for 25 years maintained a position of leadership in the Arts and Crafts concerned with sodering. Send for our Bulletins, L. B. Allen Co. Inc., 4584 N. Lincoln St., Chicago, Ill.

BLUE PRINTS

FREE CATALOG AND SAMPLE—Blue Prints of Agricultural, Furniture Making, Mechanical Drawing, Wood Turning, Forge Work, Pattern Making and Whittling Problems. Make your work more practical. Work from blue prints. Schenke Blue Print Co., 1034 Carney Blvd., Marinette, Wis.

GRANDFATHER'S CLOCK—Blue prints, finishing material and instructions. Also works, dial, weights and pendulum can be purchased from us at surprisingly low prices. Send for particulars of our attractive offer. Clock Company, 1666 Ruffner St., Philadelphia, Pa.

BASKETRY

BASKETRY MATERIALS. Reeds, raffia, wooden bases, chair cane, Indian ash, splints, cane webbing, wooden beads, braided straw, rush, willow, pine needles, stencilling materials, books, tools, dyes. Catalogue and Directions, 15 cents. Louis Stoughton Drake, Inc., 34 Everett St., Allston, Station 34, Boston, Mass.

METAL WORKING SUPPLIES

DO YOU TEACH METAL WORK—The educational value of metal construction and metal working is unquestioned. The practical instruction is far superior to wood working. Art and Manual Training easily coordinate in metal work. We have almost all the supplies required and are trying to bring about pre-war prices. Send for our catalog. Lewis & Co., Capitol Station, Box 16, Albany, N. Y.

PHONOGRAPH PARTS

PHONOGRAPH PARTS—Builders and prospective builders should send stamp for my catalogue of Reliable Motors, Tone Arms, Cabinet Hardware, Automatic Stops, Repeaters, etc. Kremer's Phono Parts Store, 118 West Court Street, Dayton, Ohio.

PRINTING SUPPLIES

TYPE—Manufacturers of Metal Type, Wood Type, Galle, Brass Rule and Printers' Supplies. In no trust or combination. Empire Type Foundry, Buffalo, N. Y., Delavan, N. Y.

PRINTERS' TYPE—The character of your printed product depends largely upon the quality of the type you use. Our material is manufactured to the highest standards, accurate, and will withstand long wear. Have your catalog? Rettew Printing Co., Foundry Dept., Reading, Pa.

ELEMENTARY HANDWORK

TAWIDO LOOMS with four treadles weave from 12" to 20" widths. Desk and Table Looms, 6" to 12". Tapestry loom 34". Shuttles, Yarnwinders, Warp Frames. Instruction in pattern weaving and tapestries. Elna M. De Neergaard, Tawido Looms Studio, 23 Union Square West, New York, N. Y.

EVERYTHING FOR ELEMENTARY HANDWORK—Also for basketry, weaving, bookbinding and chair caning. Mounting boards, Waldcraft dyes, crayons, burlap, scissors, punch and eye sets. Thomas Charles Co., 2249 Calumet Ave., Chicago.



BOOK NOTES

SEVERAL months ago The Manual Arts Press announced a new book on *Farm Blacksmithing* by John F. Friese, head of the machine shop and forging departments of the Technical High School, St. Cloud, Minn. It is now expected that this book will be ready for distribution sometime during the month of July. It is a combined textbook and problem book for students in high schools, vocational schools, agricultural schools or wherever students are studying the processes of metalwork employed in repair and construction work needed on the farm. It is also well calculated to serve as a self-instruction book for the use of farmers.

The book is the direct outgrowth of the author's experiences in teaching farm blacksmithing to farm boys. All the processes described in the book and all the problems suggested connect with the farmer's daily activities. In a very simple and direct manner, without the use of superfluous words, the author has given the fundamentals of the art of blacksmithing.

The book contains thirty plates of working drawings, and is further illustrated with 58 figures—most of them half-tones from photographs. These show processes and the completed examples of blacksmith work presented in the working drawings. They add much to the clearness and attractiveness of the volume.

As the blacksmith work of the farm is of the rougher type, this book does not give as much attention to finish as do books dealing with the blacksmith problems of the manufacturing industries or of the art craftsman. The important question on the farm is "Does it fit and is it strong enough?" In welding, for example, the question is not "How does it look?" but "Will it hold?"

With these fundamental ideas, and the author's extensive technical training, his war experience in charge of repair work at Langley Field and his several years of teaching, he has been able to produce a book that seems to be just what is wanted in its particular field.

THE MANUAL ARTS PRESS will soon publish a very richly illustrated book on *Art and Education in Wood-Turning* by W. W. Klenke, instructor in the Central Commercial and Manual Training High School of Newark, N. J. This will present wood-turning from the art craftsmanship standpoint, influenced by several years of experience in teaching the subject to high school classes.

The book will consist of 39 excellent plates of working drawings, over 60 illustrative photographs, and text matter intended to supplement the usual

class instruction of the teacher. The distinguishing characteristic of the book will be its art quality. The problems have been selected with reference to beauty of form as well as suitability in teaching the craft. One section of the book will be devoted to design in wood-turning.

The Special Schools Quarterly, the official journal of the National Special Schools Union of England, has just published the following review:—

"To those progressive teachers who are always on the look out for something good and of interest to the children, we cannot do better than advise them to procure a copy of Petersen's *Educational Toys*, published by the Manual Arts Press, Peoria, Illinois, price 1 dollar 80 cents.

"It is a real attempt to bring toy-making on sound constitutional lines into the classroom, and is the result of twenty years' work of a teacher who evidently is a lover of children. The whole work is written in simple language, the diagrams are easily "readable," and the drawings simplicity itself.

"The necessary equipment has been reduced to the absolute minimum and, as far as cost is concerned, can be purchased by most children who have acquired habits of thrift. Many of the toys are real live things when finished, giving movement which enthral and feeds imagination. Brief instructions on reproducing designs, on the use of some of the tools, on fastenings, and on the use of colour in ornamentation, render the necessary guidance to the teachers. The writer has succeeded in grouping together a series of toys which have a direct bearing on child life and environment, as distinct from mere toys of adult design.

"For institutions where industrial work is a feature of finance, and in those schools where ready sale can be found for the work of the children, this book offers full scope for organized mass production. We most heartily commend the author and publishers for the excellency of the production."

COLUMBIA UNIVERSITY has just added another volume to its studies in history, economics and public law, which is of interest to students of industrial education. It is entitled *American Apprenticeship and Industrial Education* by Paul H. Douglas, assistant professor of labor administration, The University of Chicago. The author's point of view is suggested in the last sentence of the first chapter: "The problem of the future is to devise a system which will modernize the good features of the former system and add to them merits which it did not formerly possess."



Mechanical Drawing Outfits

At Special Wholesale Prices

Set of Instruments as per Photo \$5.50

We have *now* only a limited number of sets to offer at the above *price*—Do not delay your orders—act *now*—and save 200 per cent—*While they last*—Construction of solid nickel silver and steel. Pocket case 8½ inches by 4 inches lined with green velvet. Send for catalog and prices on smaller sets, etc.

National Instrument Company

4700 North Hamilton Ave., Dept. M., Chicago, Ill., U. S. A.

Cedar Chest Material

Selected Aromatic Red Cedar of Beautiful Grain and Texture

Our lumber is bought direct from the mills in Tennessee, is seasoned especially for cabinet work and is matched to show the proper harmony of color.

Our model provides great range in construction and detail.

Parts are of larger dimension than needed, allowing sufficient for waste.

Price, without tray, \$16.00.

Price, with tray, 17.25

Above prices, F.O.B. Indianapolis, Ind.

INDUSTRIAL BOOK AND EQUIPMENT COMPANY

Indianapolis, Indiana



Manual Training Bench, No. 16

which is furnished with one Abernathy Rapid Acting Vise, and with one drawer.

Ask for our new Catalog No. 27

C. CHRISTIANSEN

BENCH MANUFACTURER

2814 W. 26th St.

CHICAGO, ILL.

LUFKIN



STEEL and WOOD RULES - - MEASURING TAPES

Complete high grade lines

On Sale Everywhere. Send for Catalog.

SPECIFY—**LUFKIN**

THE LUFKIN RULE CO. Saginaw, Mich.

New York

No. 106-110 Lafayette St.

MANUAL TRAINING MAGAZINE

EDITORS CHARLES A. BENNETT, Peoria, Illinois.
WILLIAM T. BAWDEN, Assistant to Commissioner of Education, Washington, D. C.

ASSOCIATE ARTHUR D. DEAN, Professor of Vocational Education, Teachers College, New York City
EDITORS FRANK M. LEAVITT, Associate Superintendent Public Schools, Pittsburgh, Pa.
WILLIAM E. ROBERTS, Supervisor of Manual Training, Public Schools, Cleveland, Ohio.

Business Manager L. L. SIMPSON.

Published monthly by The Manual Arts Press, 237 N. Monroe St. Peoria, Illinois.

Subscription Price, \$1.50; Canada, \$1.80; Foreign, \$2.00. Single Copies. 25 cents; Foreign, 30 cents.

Subscriptions, remittances, and manuscripts should be sent to THE MANUAL ARTS PRESS, Peoria, Illinois.

CONTENTS

THE EFFECT OF OVERCROWDING UPON INITIATIVE IN THE SCHOOL SHOP.....	<i>William F. Vroom</i> 35
CANDLE MAKING—AN INDUSTRIAL ARTS PROBLEM FOR THE ELEMENTARY SCHOOL.....	<i>L. A. Herr</i> 41
EDITORIAL REVIEW FOR THE MONTH.....	50
A Unique School Factory in Des Moines—Professor Vaughn becomes President of Hardin College—Royal Bailey Farnum goes to Massachusetts—Charles H. Winslow goes to Philadelphia—E. E. Ericson joins the Staff of this Magazine—A New Correspondent in the East—Mr. Lamkin Resigns—The Household Mechanics Course.	
A POINT OF VIEW.....	55
Peter Beowulf.	
WASHINGTON CORRESPONDENCE.....	59
Budget Bureau Organizes.	
IN FOREIGN COUNTRIES.....	60
Doubts the Practicability of Learning Trades in Modern Commercial Shops—Sloyd School in Askor, Denmark.	
PROJECTS, PROBLEMS AND NOTES.....	62
Crate Corners—Bookcase—Miter-Box Table.	
CURRENT PUBLICATIONS.....	68
FIELD NOTES.....	IV
From New Jersey—Southeastern Items—Around New York—From the Southwest —Keeping Children in School—The School Must Solve the Child Labor Problem— George F. Weston goes to California—The Milwaukee Meeting—Foreman Conference in Seattle—The National Society to Meet at Kansas City—New England Items.	
TRADE NOTES.....	XXVIII
BOOK NOTES.....	XXXVII

This Magazine is kept for sale at McClurg's in Chicago, and Brentano's in New York.

Entered at the Post Office at Peoria as Second-Class Matter. Copyright, 1920, The Manual Arts Press.



FIELD NOTES

FROM NEW JERSEY

MODEL YACHT RACE

THE Model Yacht *Harding*, owned and made by Patsy Marole of the Cleveland Alternating School, Newark, N. J. won first prize in the inter-county model yacht race for boats made by boys in the public schools, held under the auspices of the Irvington Model Yacht Club Saturday, June 25th at the Essex County Park Lake, Irvington, N. J.

The race from one end of the lake to the other, a distance of 780 ft., was close, the *Harding* and the *Liberty*, owned by Henry Wenzel of the Augusta Street School, Irvington, N. J., finishing less than twelve inches apart. Hundreds of interested spectators watched the race from the banks.

Silver loving cups donated by the Jennings Silver Company and the Irvington Model Yacht Club, were presented to the winners at the close of the contest.

About twenty boats were entered from Montclair, Irvington, East Orange and Newark. Model yacht building has been accepted by many Essex County manual training instructors as a project overflowing with informational content and of exceptional fascination to boys. Interest in this school activity on the part of members of the Irvington Club is doing a great deal toward placing this work on a high plane in the estimation of the boys themselves, and results of an unusual standard of excellence are being obtained.

ESSEX COUNTY ARTS ASSOCIATION MAKES PLANS FOR NEXT YEAR

The members of the Executive Council of the Essex County Arts Association held a meeting on June 8th to discuss plans for the year 1921-22. As a result a general meeting will be held in October, probably at the Central High School, Newark. Four departmental meetings will be held on the same day in November at the East Orange high school. A second series of departmental meetings will occur in February. It is the purpose of the officers to hold a general meeting and dinner in March at which a speaker of wide reputation will be present to bring an inspirational message to members.

The department meetings will be in the nature of round tables with helpful and experienced leaders who will direct general discussions in which all may take part.

At the last general meeting of the Association the following officers were elected: president, Miss Mabel J. Chase, Supervisor of Drawing, Newark; vice-president, Harold F. Fuller, Principal of the

Boys' Vocational School, Newark; secretary and treasurer, Charles R. Collins, East Orange High School; chairman of the art Section, Miss Marguerite Marquart, Newark; chairman of the Household Arts Section, Miss E. E. Frost, Irvington; chairman of Industrial Arts Section, Frederick R. Price, East Orange; chairman of Vocational Arts Section, Harold F. Fuller, Newark.

CONFERENCES OF NEW JERSEY VOCATIONAL SCHOOL DIRECTORS

The directors of the state aided vocational schools of New Jersey have been holding a series of monthly conferences during the school year under the leadership of the State Department of Public Instruction. These conferences grew out of a feeling on the part of various directors that periodical discussions of problems with which they were all concerned would be of mutual help in developing the work of their schools.

At the request of several of the men, the State Department called the first conference at the Middlesex County Vocational School in New Brunswick last December. As a result of this meeting, it was agreed to come together once a month at the various vocational schools for the purpose of conference and inspection of the school work. It was planned to devote the first half of the day to inspecting the work of the school visited, and the last half to a round table for discussion of certain topics determined in advance.

At the first meeting the group framed a series of definitions to serve as a basis for their discussions, and formulated questions for consideration in future meetings:

These questions touched on the following topics:

1. Character of Instruction in Trade Technical Subjects.
2. Teaching Methods.
3. Teaching Material.
4. Records.
5. Practice.

In addition to the round table discussion arranged for at the first meeting, it was also decided to appoint committees from time to time to make a special study of certain questions included in the programs.

At the request of the members of the conference, the assistant commissioner of education, Wesley A. O'Leary, assumed the chairmanship of the meetings and made the discussion assignments. One man was designated as leader of the discussion for each question, but each member of the conference was expected to be prepared in advance to participate in the discussion of every question. The lead-

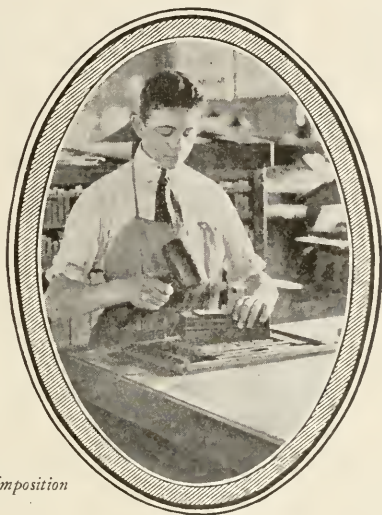

Imposition

Imposition

Teaches Caution and Accuracy

THE technical process in printing known as imposition is a valuable method of teaching mechanical accuracy. Imposition is the arranging of page or job type forms in their proper relation and locking them up in chases to be printed on the press.

The correlative study is mathematics, and woe be to the pupil who does not apply mathematics to his work in imposition of type forms. The unit of measurement in the printing craft is the point, and the point is .0138 + (approximately $\frac{1}{72}$) of an inch. The

omission of one point or the insertion of an extra point may prevent the satisfactory locking up of a type form.

Orderly arrangement and careful margining are also vital requirements in imposition. Problems in arithmetic based on type measurements are easily arranged.

Should you be considering the installation of a school print shop, the entire service resources of this company, including experienced educators, efficiency engineers and selling organization, are at your disposal. Write to-day.

F. K. PHILLIPS, *Manager*, EDUCATION DEPARTMENT

AMERICAN TYPE FOUNDERS COMPANY

JERSEY CITY, NEW JERSEY

BOSTON, MASS.
NEW YORK CITY
PHILADELPHIA, PA.
BALTIMORE, MD.
RICHMOND, VA.

BUFFALO, N. Y.
PITTSBURGH, PA.
CLEVELAND, OHIO
CINCINNATI, OHIO
ATLANTA, GA.

CHICAGO, ILL.
DETROIT, MICH.
ST. LOUIS, MO.
MILWAUKEE, WIS.
MINNEAPOLIS, MINN.
WINNIPEG, CANADA

KANSAS CITY, MO.
DENVER, COLO.
PORTLAND, ORE.
SAN FRANCISCO, CAL.
SPOKANE, WASH.

LOS ANGELES, CAL.



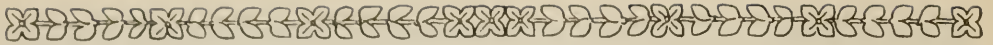

FIELD NOTES—(Continued)

er was not required to submit a written discussion, altho in most instances a paper was prepared. The State Supervisor of Industrial Schools served as secretary of the meetings and a full report of every meeting was mimeographed and sent to each member of the conference.

While the meetings were intended primarily for vocational school men, from time to time local superintendents of schools were invited to participate in the discussions. These invitations were always accepted and this exchange of ideas between the directors and superintendents was very helpful. At a recent meeting in Paterson the secretary of the Associated Industries of Paterson was a guest of the conference and presented a discussion of the question as to how industry and the vocational schools can develop closer relationship.

The meetings have been held at the vocational schools in the following districts: New Brunswick, Bayonne, Elizabeth, Newark, West Orange, Bloomfield, and Passaic.

A pleasant feature of these meetings has been a dinner served by the Girls' Vocational Schools at which the members of the conference were the guests of the home economics department. The last meeting of the season took the form of an outing and dinner to which the members of the conference invited their families.

These meetings have done much to promote a feeling of good fellowship among the men and a better understanding of their common problems. It is expected that the meetings will be continued next year.

—ALLEN D. BACKUS.

SOUTHEASTERN ITEMS

MANUAL TRAINING IN GREENVILLE

MANUAL TRAINING was introduced into the schools of Greenville, S. C., in rather a unique manner. It was tried out outside of the school system first, and the benefits were so evident that there was no doubt left relative to its value.

R. S. Huntington, president of a large construction company, started a class in Caperdown Mill village two years ago. Regardless of the fact that he was a business executive of prominence in Greenville, he willingly took his own time to teach the Caperdown Boys' Club class. Thruout the year he labored in laying a foundation for the employment of a full-time teacher and the introduction of manual training in the schools. These efforts resulted in the securing of the services of Ben. W. Young of Nashville, Tenn.

Mr. Huntington's belief in manual training is sincere and strong. He regards it as a sort of "labo-

ratory of life experience." "In the broadest sense," he says, "manual training educates the boy for the meeting of the real life problems which are to come later. Well taught, it is more effective in developing the fundamental traits of accuracy, neatness, thoughtfulness, confidence, concentration, and so forth, than all the precepts that could be pumped into him in years of preaching by his elders. It aids and supplements academic training because it deals with faculties more than with facts, while the reverse generally is true of academic training."

Mr. Huntington summarizes the benefits derived by the boy from manual training, as follows:

"The formation, thru constant repetition of habits of accuracy, neatness, thoughtfulness, patience and perseverance, and, in a broad sense, gaining of self-confidence thru the repeated accomplishment of things thought to be beyond his ability: the habit of thinking positively instead of negatively when confronted with a new problem and of simplifying it by analysis of its component parts; in general, the habit of thinking thru to a conclusion and making his thoughts effective in action."

An exhibit of the work done during the past year under the supervision of Mr. Young was shown in several of the large show windows of the business houses. The various pieces were well executed, and their appearance made a very favorable impression. The department will have large and better quarters next year. The school authorities have decided to provide sufficient space for the work.

INDUSTRIAL WORK IN BIRMINGHAM

THE industrial and vocational work in Birmingham, Alabama, has been developing very rapidly recently. R. F. Jarvis, director, reports the following work completed or in progress:

Two all-day unit trade schools in machine shop practice and one in drafting; also one each in shoe repairing and chauffeur mechanics for negroes. In part-time trade extension work there are three classes in blue-*r*int reading and shop mathematics, one in machine tool operation and four in salesmanship. Two classes are conducted for part-time pupils and there are eleven trade extension evening classes, including one in cleaning and pressing and one in chauffeur mechanics for negroes.

—FOREST T. SELBY.

AROUND NEW YORK

IN THE library of Stuyvesant High School there is on public view a special exhibition of work done by the Crafts Club. One of the most novel exhi-



THE FORGES AT M. I. T.

FOR many years, Sturtevant Forges were used in the blacksmith and forge shops of the Massachusetts Institute of Technology. Five years ago, when the new buildings were erected in Cambridge the shops were again equipped with 26 H-1 Down Draft Sturtevant Forges. Satisfaction must have been the cause of this duplication.

A Sturtevant Forge installation is complete—it is a system including forge, exhaust fan, and necessary duct work, designed and placed in the building with constant forethought toward the users entire satisfaction.

Would you care for further data?

Address: **B. F. STURTEVANT CO.**
HYDE PARK, BOSTON, MASS.

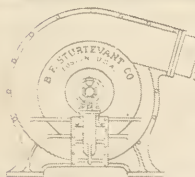

Sturtevant

REG. U.S. PAT. OFF.

PUTS AIR TO WORK



FIELD NOTES—(Continued)

bitions is a miniature reproduction of the home and estate of one of the art teachers. The work has been most skillfully executed by a sixth-term student, and is the equal of work done by professional architects and landscape artists.

Morris High School students have won two art trophies in competition with the high schools of the city—the Municipal Art Society trophy for good draughtsmanship, and the School Art League trophy to advanced pupils in the three-year elected course. The Municipal Art Society trophy contest was held under the supervision of Dr. James Haney, director of art in high schools. The pupils competed, not as individuals, but as groups, representing different high schools. Morris High scored a total of 141.3 points out of a possible 150. Flushing High secured second place and Boys' High third. In the contest of the School Art League, Morris finished with 143.8 points out of a possible 150. Evander Childs secured second place, and Manual Training third. Morris will hold both trophies for six months. The next contest is scheduled for January, 1922. J. Winthrop Andrew, director of manual arts, Yonkers; Joseph V. Baron, director of drawing, Mount Vernon; and Dr. Haney acted as judges in both contests.

Encouraged by the progress made by the New York University School of Retail Selling, the merchants supporting the school decided at a dinner at the Aldine Club to undertake a campaign for an endowment that will put the school on a permanent basis. Director F. Norris Briscoe pictured the future of the school in optimistic terms and congratulated the merchants upon securing for retail selling recognition as a profession. He pointed out that this year at New York University, for the first time at any university, a school of retail selling shared the program with the schools of law, medicine and other professions. The supporters of the school, graduates, educators and others interested in following the progress of the co-operative attempt of merchants, the university and the local department of education to train teachers of retail selling and store executives, listened not only to a review of the work achieved, but to federal and state specialists in commercial education on the importance of education in retail selling, and the great need of similar schools.

E. W. Barnhart, chief of the Commercial Education Service of the Federal Board for Vocational Education outlined the present need for men and women trained in selling, and emphasized the importance of providing a system of training. The sales person of the future who would be most suc-

cessful, he suggested, would be the one best able to prescribe, to tell people what they ought to buy. There never was greater need than that which existed today for institutions that would train teachers for retail selling.

Paul S. Lanax, specialist in commercial education, in the State Department of Education, declared that training in retail selling was a major demand in education that must be met. More people are engaged in that work than in any other branch of commercial employment. Nothing is so encouraging in the present situation as the progress made by the New York University school in training in retail selling. The more the schools through continuation classes, part-time, and evening courses come into close contact with young people at work, the more evident becomes the need for giving attention to the field of retail selling and the large opportunities it offers to boys and girls.

Dr. Paul H. Nystrom, director of the Retail Research Association, referred in turn to the department stores, the chain stores, and the mail order houses. He traced the development of accounting systems, of delivery, and of sales to show the complexity of the organization, and the increasing need for specialists to continue to work to improve them. "The people are paying too much," he declared, "because so much is wasted in bad methods."

Percy Strauss of R. H. Macy & Co., chairman of the executive committee, remarked that the cost of distribution today was staggering. It was but another evidence of the kind of problem the school would help to solve. He sketched briefly the development of the school during the past two years and declared that the school had a big future.

—W. H. DOOLEY.

FROM THE SOUTHWEST

THE following report comes from Henry F. Holtzclaw, state supervisor of trades and industries for the state of Oklahoma.

"Since 1918 the development in the field of trade and industrial education, as carried on by the Oklahoma State Department of Vocational Education, has been along the line of the all-day trade class and the part-time and evening school, as the latter two concern the training of workers in the industrial plant. Passing attention has been given to the training of executives and technical experts.

"For some time, however, the officials of the Department have had in mind the foreman, sometimes spoken of as the middle man, but only recently have they succeeded in putting on a foremen's conference in the plant of Cosden and Company, Refiners, of

LITTLE GIANT

MANUAL TRAINING DEPARTMENT

Special Equipment

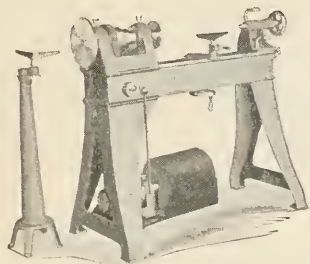

LITTLE GIANT WOOD LATHES

Individual Motor Driven, or Belt Driven from above or beneath.

Furnished with either Bench or Floor Legs. Wide choice of optional tools and equipment. Four speeds.

Many new, exclusive and practical features. All bearings are Hyatt High Duty Roller Bearings which greatly reduce power required. Ball Thrust bearings at all points of end thrust.

Sold on 30 days trial, and GUARANTEED FOREVER against defective material and workmanship.

LITTLE GIANT METAL LATHES

Individual Motor Driven, or Belt Driven from above or beneath.

Furnished with either Bench or Floor Legs. Wide choice of optional equipment. Three speeds.

Many new, exclusive and practical features are also found on our metal lathes. They are fitted to receive attachments for grinding, milling, gear cutting, etc., all of which we will furnish at a small fraction of the cost of a separate machine for such work.

Sold on 30 days trial and GUARANTEED FOREVER against defective material and workmanship.



LITTLE GIANT POWER HAMMERS

Individual Motor Driven, or Belt Driven from above. Hundreds of different form-forging dies for instruction purposes.

Standard equipment with leading Technical and Manual Training Institutions.

Sold on 30 days trial, and GUARANTEED FOREVER against defective material and workmanship.

DO NOT OVERLOOK

Metal Working Equipment in your school. Wood can never be made anything else, while metal working and alloying are in their infancy.

The Industrial Leaders of the world, to a very large extent, began as metal workers.

Wood working is artistic, and trains mind, eye and hand to deftness. Metal working does all this, and more. It is also practical, and the graduate invariably finds a position waiting for him, while the wood working department graduate usually takes up something else and his instruction is forgotten.

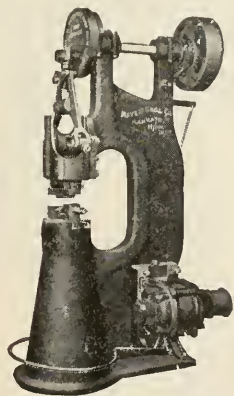

Little Giant Equipment for Technical and Manual Training Schools consists of a full line of all metal and wood working machinery including accessories and tools for same.

On Motor Driven Equipment, information will be required as to Current, Voltage, Phase and Cycles of Motor.

Our business commenced in January, 1876, more than 45 years ago, and our Little Giant Products are used throughout the world. We are anxious to serve you for we can do it well.

Quotations and descriptive literature can be secured from any jobber, or direct from us.



LITTLE GIANT COMPANY

220 ROCK ST.

MANKATO, MINN., U. S. A.



FIELD NOTES—(Continued)

Tulsa. The conference lasted for two weeks, and twenty head foremen were in attendance.

"The course was an intensive study of the instructor, the man and the job. The class was promoted by Charles W. Briles, state director of vocational education and Henry F. Holtzclaw, state supervisor of trade and industrial education, in cooperation with E. E. Oberholtzer, city superintendent of schools of Tulsa. The conference was in charge of Frank Cushman, agent for industrial education for the Federal Board for Vocational Education. In the conference, the foremen were first directed in an effort to analyze the problems of foremanship as these problems relate to their responsibilities as a supervisor, manager or instructor. Attention was then directed to the problems of job analysis.

"The instructor worked individually with the men, aiding them in determining for themselves, just what job each man in the organization is expected to do, of what operations and processes each job consists, and what a man needs to know, in order to do successfully what is expected of him. Later in the conference, an effort was made to find a logical instructional order for the material developed in the several departments as a result of their studies in job analysis, and finally each foreman was called upon to prepare an operation sheet for the instructing job. Practical demonstration work in the various departments of the plant supplemented the conference discussion."

—E. E. ERICSON.

KEEPING CHILDREN IN SCHOOL

ANYONE interested in standards affecting the employment of minors in day, continuation, and night schools should consult the chart entitled "State Compulsory School Standards Affecting the Employment of Minors," published by the Children's Bureau of the U. S. Department of Labor.

Every state now has a compulsory day school attendance law. In five states attendance is required until 18 years of age, in two of these in certain districts only; in 3 until 17; and in 32 until 16. One state requires attendance until 15, six others and the District of Columbia until 14, and one state requires attendance until the age of 12 years, but applies this to illiterates only.

Unfortunately, the exemptions in the majority of states are so numerous that they greatly limit the application of the law. The most common exemptions are for employment, or upon completion of a specified school grade. Four states specifically exempt for work in agricultural pursuits, 3 with no

age provision. The laws of 14 other states contain loosely worded provisions exempting a child at any age, which might be used to cover absence for farm work as well as for many other purposes. Several states exempt a child whose services are necessary for the support of himself or others, without any age or educational provision.

The amount of attendance required is still unsatisfactory in many states, several demanding only 12, 16 or 20 weeks in a year. Even in states where city children must attend for 8 or 9 months, the amount of attendance required in rural school districts is sometimes considerably less.

THE SCHOOL MUST SOLVE THE CHILD LABOR PROBLEM

AT THE 16th National Conference on Child Labor at Milwaukee, June 24th, Owen R. Lovejoy, general secretary of the National Child Labor Committee, presented a report of recent investigations made by the Committee in rural sections of Oklahoma, Colorado, Alabama, Kentucky, Tennessee, and other states.

The most serious aspect of rural child labor, as shown in this report, is its interference with school attendance. In spite of the fact that so many children stay out of school and work, actual poverty is not the important factor in the majority of cases. As a beet grower in Colorado said to a representative of the Child Labor Committee staff, "My boy is worth \$1,000 for work during the beet season, but is nothing but an expense when he goes to school." Another family, who boasted that they had made \$10,000 from their farm during the preceding year, were allowing their two children to work in the fields during school hours. "The failure lies as much with the school as with the parents or the children," says Mr. Lovejoy. "To the parent, in many instances, the work of the school appears unpractical and unimportant; to the child it is often monotonous and irksome. With such a combination there is only one place to turn for a solution of our rural attendance problem, and that is the school itself. Until we provide rural schools which are attractive in appearance, well equipped, well taught and vital to the life of the community, neither the rural school attendance nor the rural child labor problem will be solved."

GEORGE F. WESTON GOES TO CALIFORNIA

THE installation of manual training in the Providence public schools began when George F. Weston, then principal of the Vineyard St. school,

Accuracy First—

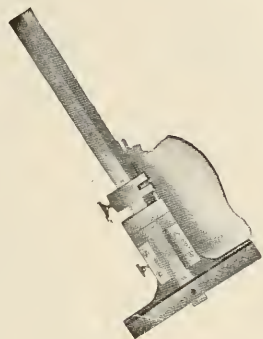

"Remember that accuracy is the first requirement of a good machinist. Speed comes after.

"Starrett Tools are absolutely accurate. You can depend on 'em.

"In the long run, that means more than getting jobs done right—it means saved time and saved material. All of which helps save your job when the tool-borrowing, time-wasting, botch workers are being weeded out of the shop.

"Overhaul your Starrett Tool kit first chance you get. Make it complete. Keep watch for the new Starrett Tools and get 'em. The more Starrett Tools you have, the better you are fixed to handle any job you get.

"When you go home tonight, it would be a good idea for you to drop into the hardware store and look over the Starrett line.

"Get posted on tools you need. Write for the Starrett Catalog No 22 EF."

THE L. S. STARRETT CO.

*The World's Greatest Toolmakers
Manufacturers of Hack Saws Unexcelled*
ATHOL, MASS.



© 1921



Use Starrett Tools



FIELD NOTES—(Continued)

found two oak planks left by a contractor. With these, and a few tools he purchased, he interested some boys. This was followed by a gift of \$200 from a neighbor. Later Mr. Weston was made principal of the Manual Training High School, with the understanding that he would be given two years to make a success of the movement. At the end of that time, so many pupils were leaving the schools to go to the manual training school that the school committee was considering the advisability of closing it. He was principal of this school, later called the Technical High School, for 20 years. Four years ago he became superintendent of schools in Johnston, but he has recently resigned to go to California. The Olneyville Business Men's Association have tendered him a farewell reception to convey their appreciation of his services to the community.

THE CARNEGIE CORPORATION has agreed to give \$6,590,000, unconditionally, to the Carnegie Institute of Technology, Pittsburgh, Pa., for expense over a period of 25 years, for repairs and replacement of equipment and for gymnasium. In addition, the sum of \$8,000,000 will be given, if \$4,000,000 is raised from other sources. The Institute, originally intended primarily for the young people of Pittsburgh, has far exceeded its original scope, nearly half of its 4,000 students coming from outside Pittsburgh. The corporation feels that it must eventually look outside for funds in any case, and that placing a condition on the present gift will serve to bring the school and the community into closer sympathy.

MANUAL TRAINING, in the form of chair caning, rug weaving, elementary carpentry and joinery, is taught to the mentally defective in Public School 64, New York City. Principal Louis Marks believes that concrete objects appeal to such students and that they become more alert and interested in book work as a result of manual training.

The mentally defective constitute only one of four classes of exceptional students that are given special attention. Miss Elizabeth Irwin, psychologist, tests all students and divides them into: (1) gifted children, who do the eight years' course in six years; (2) bright children, who take seven years; (3) average children who take eight; (4) dull normal children, who take ten; and (5) mentally defective children, who are given different work. In addition to these pupils, two classes of intelligent children have a special room containing a piano and nature study equipment. The class visits museums and parks, studying arithmetic or drawing without regard to the course of study.

The *Chicago Tribune* has offered a prize of

\$5,000 to the student of the Chicago Art Institute who shall submit the best and most acceptable mural design for the city room in its new plant. The subjects for the three panels will be: (1) the bringing in of the verdict of not guilty in the case of the King vs. Zender for libel; (2) the sitting of the American congress in which the constitutional amendments safeguarding the liberty of the press were adopted; (3) the pre-war conference in the old Tribune office in the late '50s between Abraham Lincoln and the early editors of the Tribune concerning measures which eventuated in the liberation of the slaves and "union one and indivisible."

Students entering school in September, 1921, will be eligible as contestants. The Institute offers ten free scholarships for the year 1921-22 on a competitive basis to painters who take up work on the Tribune designs. These scholarships will be open to painters, not now enrolled, who shall enroll before Oct. 1, 1921. Every artist so enrolling shall accompany his request to enter the scholarship contest with (1) a composition in color (2) five life drawings and (3) a life painting. These must be submitted by Sept. 15, 1921, and should be addressed to Mural Scholarship Competition, Chicago Art Institute.

THE MILWAUKEE MEETING

THE Vocational Education Association of the Middle West will hold its eighth annual meeting in Milwaukee in January 1922. The exact dates will be announced later. The splendid Auditorium in that city will be at the complete disposal of the Association. The main hall seats 10,000; in addition there are half a dozen halls of various sizes ranging in capacity from 100 to 600 people. All the sectional meetings as well as the commercial exhibits will thus be housed under one roof. The arrangements will therefore be ideal, as far as physical requirements for the meeting are concerned. But coupled with this ideal condition is the enthusiasm and the spirit of the Milwaukee local committee. This committee has already organized under the auspices of the Association of Commerce, the public schools and other groups of people not of Milwaukee alone but of all the surrounding communities; Cudahy, West Allis, Wauwatosa and Sheboygan. A well developed working plan has been adopted and all the industrial and educational forces have set out to make this the biggest meeting on vocational education which has ever been held in the Middle West.

The opportunity offered at this meeting to study the vocational education program as worked out in

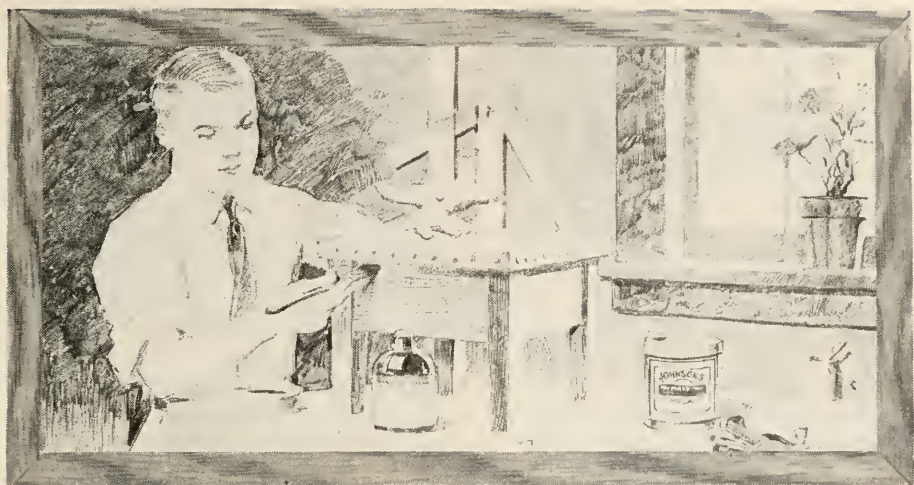

“Simply Stain It—Any Color— with Johnson’s Wood Dye”

JOHNSON’S Wood Dye is just the preparation for staining manual training models. It is very easy to use—goes on like oil without a lap or streak. It is made in thirteen attractive shades—which may be easily lightened and darkened. Complete instructions are given on every label.

JOHNSON’S ARTISTIC WOOD FINISHES

Johnson’s Artistic Wood Finishes are now being used in nine-tenths of the schools in the Country. They are particularly adapted for manual training work as they may be applied by the youngest and most inexperienced pupils with the best results.

The Johnson Wood Finishes most popular among Manual Training Instructors and Pupils are *Johnson’s Wood Dye, Prepared Wax, Under-Lac, Paste Wood Filler, Flat Varnish, PerfectTone Under-Coat and PerfectTone Enamel*. We have a very attractive exhibit of wood panels finished with these products which we are glad to send Manual Training Instructors who will give it wall space in their shop. Write for it.

Beautiful Instruction Book Free

Write for our beautiful new thirty-two page color booklet “The Proper Treatment for Floors, Wood-work and Furniture.” It is full of valuable information on artistic wood finishing. Do not hesitate to send for it. We will gladly furnish it upon request free and postpaid.

S. C. JOHNSON & SON, Dept. M.T.8, Racine, Wis.

“The Wood Finishing Authorities”
CANADIAN FACTORY—BRANTFORD



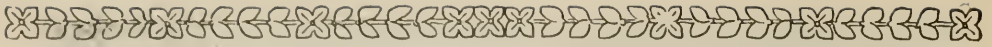

FIELD NOTES—(Continued)

Milwaukee will be one which no one interested in this form of teaching can afford to miss. The part-time and continuation schools, the Boys' Trade School and the Girls' Trade School, pioneers in this line of work, have kept far in the front in the movement during the past years. In no other place in the country has the community provided so generously for this form of education, not only thru state funds but by the city. A study of this work at first hand is alone worth the trip to Milwaukee. School directors and superintendents are beginning to recognize the value of such study when coupled with a live convention and a good program, and are sending members of their teaching and supervisory staff as delegates representing their schools and communities. Teachers and others interested should see that this matter is brought to the attention of the right parties in good season.

The Vocational Education Association of the Middle West, by means of the successful meetings of the past, has assumed an enviable position in its own section of the country which ranges from Ohio on the east to Kansas and Nebraska on the west, and from Minnesota and the Dakotas on the north to Oklahoma and Kentucky on the south. The total number of members from this section has increased from 263 in 1917 to 650 in 1921. The registration at the Minneapolis meeting in 1921 exceeded the total for 1920, in spite of the fact that the meeting of 1920 was held in the center of the territory, and was a joint meeting with the National Society of Vocational Education. This is proof that the Association has established itself as filling the needs of the Middle West and is meriting support.

In spite of increasing costs in every line, and the fact that some educational associations have found it necessary to increase their dues, a dollar today pays for a year's membership in this association just as in days "before the war." Every superintendent, supervisor, teacher and school board member interested in Vocational education in the Middle West should be a member of this live organization. A dollar mailed to the secretary, Leonard W. Wahlstrom, 1711 Estes Ave., Chicago will take care of the matter.

"A thousand members for Milwaukee in 1922—
Let's, Go!"

—L. W. WALSTROM.

SOUTH BEND, INDIANA, according to G. F. Weber, director of vocational education, is planning to build a \$500,000 thirty-four room combined grammar and junior high school building within the next year. The Vocational Education Depart-

ment will have three shops: a drawing room, a print shop, and a large varied industry room, especially designed for teaching several of the more essential trades.

The new Oliver School will probably be ready for occupation before Christmas. This is the largest school building in the system and combines grammar and junior high school. The Vocational Education Department will have a complete machine shop, auto shop, and varied industries shop, including woodworking and finishing, and electrical, sheet-metal, forging and foundry work. There will also be a print shop and a drawing room.

THE BOURNE WORKSHOP FOR BLIND MEN is maintained in connection with the New York Lighthouse for the Blind, to permit those without sight to become wholly or partially self-supporting. Many of the workers have been there for years, have become adept, and make very comfortable livings for themselves and sometimes for wives and children. Others, who have lost their sight late in life thru industrial accidents, come to the workshop with nerves shattered from the shock. These can earn little at first, but with the help of patient teachers they are enabled to occupy a useful place in the world. Connected with the workshop is a boarding house where the workers may live in a home atmosphere for a nominal sum. In this workshop about 280 floor mops, are turned out daily, and sold to factories, hospitals, offices and institutions. In the same workshop, forty blind men are employed as broom makers and their daily output averages seventy dozen. Chair caning also is done on an extensive scale.

FOREMAN CONFERENCE IN SEATTLE

JUNE 4th marked the close of a two weeks' foreman conference at the Fisher Flouring Mills, Harbor Island, Seattle. The conference was held at the invitation of the State Board for Vocational Education, and, while the management co-operated, the final consent rested in the hands of the foremen themselves. The discussion method was used, Prof. Henry Jensen, State Supervisor of Trades and Industries, leading, and was far more effective than a series of lectures. Three hours a day were devoted to topics such as job analysis and co-operation. The human factor is so important in the work of a foreman that many of his problems have general application and may profitably be discussed by other departments. The foremen feel that the conference has been a decided success, and have invited the other departments of the mill and the management to meet with them.

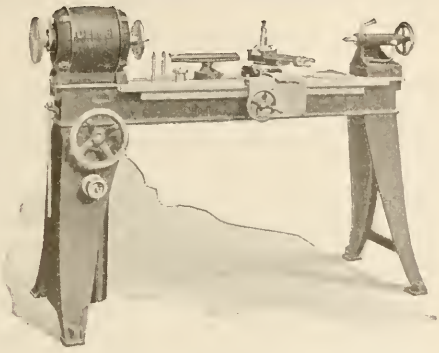

No. 51-E Motor Head Lathe, Four Speed,
3 Phase, 60 Cycle, 220 Volt Motor and
Controller—Front View.



Over 1200 Schools use "Oliver" Tools

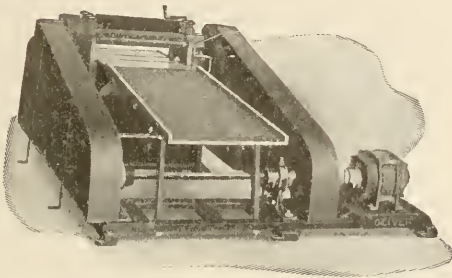

Rear View "Oliver" No. 99 Surface Planer.
Several methods of motor drive are furn-
ished—write for details.

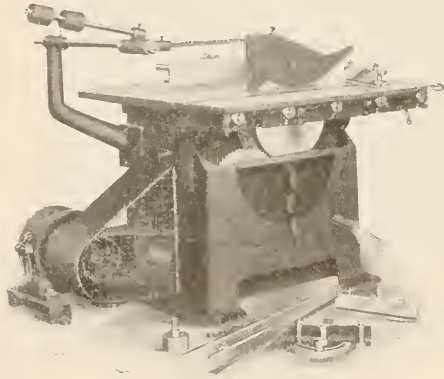

"Oliver" No. 60 Universal Saw Bench
Exceptionally accurate, easy to operate
and durable—built in two sizes.

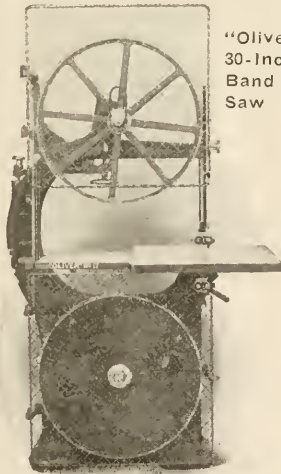

"Oliver"
30-Inch
Band
Saw

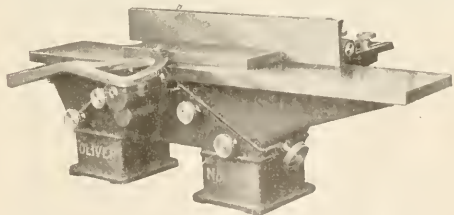

"Oliver" No. 144-A Jointer.
"Oliver" Jointers from 4" Portable up to 30"

**"Oliver" Quality
Woodworking
Machinery
for
Furniture Factories
Pattern Shops
Woodworking Plants
Manual Training**

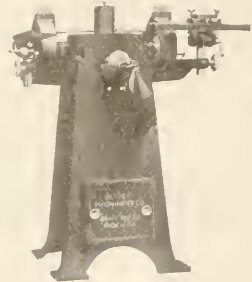

"Oliver" No. 581 Re-
volving Oilstone
Tool Grinder.
For sharpening
gouges and edge tools
of all kinds.

OLIVER MACHINERY CO.

Grand Rapids, Mich., U. S. A.

Branch Offices or Sales Engineers in Principal Cities

The Cass Series Now Ready!

THE three Cass Technical High School Mathematical Books, despite printers' and binders' strikes, are now on the market. Copies will be cheerfully sent for Free Examination, on request.

PREPARATORY MATHEMATICS FOR USE IN TECHNICAL SCHOOLS

By HAROLD B. RAY and ARNOLD V. DOUB, Instructors in Mathematics, Cass Technical High School.

A preparatory course for students in night schools, continuation schools, vocational schools, etc., who have not had the advantage of previous training in even the most elementary mathematics.

70 pages, 4 $\frac{7}{8}$ by 7.

70 Figures—\$1.00 postpaid.

MATHEMATICS FOR ELECTRICAL STUDENTS

By H. M. KEAL, Head of Department of Mathematics, and C. J. LEONARD, Instructor in Mathematics, Cass Technical High School.

A mathematical text written especially for electrical students and workers, with applications drawn from practical electrical work.

230 pages, 4 $\frac{7}{8}$ by 7,

165 Figures—\$1.60 postpaid.

MATHEMATICS FOR SHOP AND DRAWING STUDENTS

By H. M. KEAL and C. J. LEONARD.

A book similar to "Mathematics for Electrical Students," except that problems of practical applications from shop-work, instead of electrical work, are given.

213 pages, 4 $\frac{7}{8}$ by 7,

188 Figures—\$1.60 postpaid.

Fill in and send the coupon NOW—the books will be sent to you at once.

USE THIS COUPON

John Wiley & Sons, Inc.,
432 Fourth Avenue, New York City.

You may send me the following on 10 days' approval:

Ray & Doub's Preparatory Mathematics for Use in Technical Schools

Keal & Leonard's Mathematics for Electrical Students
Keal & Leonard's Mathematics for Shop and Drawing Students

I agree to pay for the books or return them within 10 days of receipt.

Also please send me a copy of your Vocational News and put my name on your mailing list.

Name.....

Address.....

If teacher, state school.....

If not teacher, give reference.....

M.T.M. 8-21

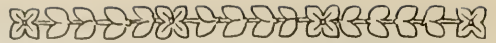

FIELD NOTES—(Continued)

THE \$1,000 prize offered by Alvan T. Simonds, president of the Simonds Saw Manufacturing Co., for the best essay on the subject "Present Economic Conditions and the teachings of Adam Smith in the *Wealth of Nations*" was awarded to David Koch, aged 17, a resident of the east side of New York City. His father is a button-hole maker, and came from Russia. The boy began to read books on economics at the age of 13, and is said to know more about the subject than some of his teachers. He expects to use the money toward a college education.

DURING THE LAST WEEK of the year the Vocational School at Holyoke, Mass., filled two large orders, one for 50 student desks for the Parfitt Furniture Co., made by the boys in the carpenter shop, and the other for 43 regular school desks for the public schools, made by the pattern-making students. The orders were taken to give the boys training in factory methods, with all parts made duplicate and interchangeable. Several difficult joints were involved, and the machine shop made some necessary special tools which could not be found in the market.

THE NATIONAL SOCIETY TO MEET AT KANSAS CITY

THE next annual convention of the National Society for Vocational Education will be held in Kansas City, Mo., on January 12-14, 1922. This is in accord with the resolution adopted at the Atlantic City meeting urging that the next convention be held in the Middle West. This will be the first time that the Society has ever held its annual convention in Kansas City.

AT THE N. E. A. MEETING in Des Moines, July 3rd to 8th, the Department of Vocational Education and Practical Arts held two sessions. At the first of these K. G. Smith, state supervisor of industrial education for Michigan, spoke on "Establishing a State Program of Part-Time Education." The president of the Department this year was W. G. Hummel, state director for vocational education, Olympia, Wash. The president elected for the coming year is W. H. Bender, state director of agricultural education in Iowa.

RICHMOND, INDIANA, is erecting a new junior high school building and will start another as soon as financial conditions are more favorable. In each school there will be two large shops, one which will be called the general wood shop and the other the general metal shop. In the former, bench-work, wood-turning, cement work and electrical work will be taught; in the latter, sheet-metal work

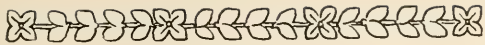

FIELD NOTES—(Continued)

machine shop work, foundry work and some electrical construction. A third room, called the mechanical drawing room, will belong to this shop group.

A GROUP OF STUDENTS in the automobile class of the high school at Portland, Maine, has recently constructed a servicable automobile out of "the discarded parts of some 14 machines which had gone to the scrap heap."

MANUAL TRAINING and domestic science are to be added to the high school curriculum at Newburyport, Mass., this fall. They will be given to students of the first and second years of the general and commercial courses.

MEDICINE CHESTS and bandage cabinets for the use of the Red Cross are reported as having been made by the manual training classes at Southington, Conn.

THE SOUTH CAROLINA INDUSTRIAL SCHOOL for White Boys, Florence, S. C., has, within the past few months, installed a manual training shop at a cost of less than \$2,000, as a means of teaching how to combine knowledge with practical work. At first the boys could not read or write; they began with manual training toys and tracing work under the direction of H. B. Skinner, Director of Manual Training. Today all can read and write, and read working drawings as well. The boys of the school publish a monthly magazine, "The Life Buoy." Cabinet work has been undertaken, and some boys repair furniture, in return for which money is deposited to their credit in the school bank.

There is also a small class in motion picture operation, which has placed students in local picture houses.

Manual training has made such gains in South Carolina that an attempt will be made next fall to organize a state society for the instructors, with an office in Columbia.

DURING THE PAST YEAR the trade school at Hampton Institute has had the largest entering class in full trade work for the past nine years. Exclusive of disabled soldiers, agricultural, work-year and work-day students, 210 are enrolled in regular or special courses in auto mechanics, blacksmithing, bricklaying, cabinet-making, carpentry, drafting, machine work, painting, printing, shoe-making, steamfitting, tailoring, upholstering, and wheelwrighting.

The automotive department continues to be popular; in the next few years there will probably be a large demand for negroes who can handle and repair automobile trucks and farm tractors. The printing department is using the two linotype

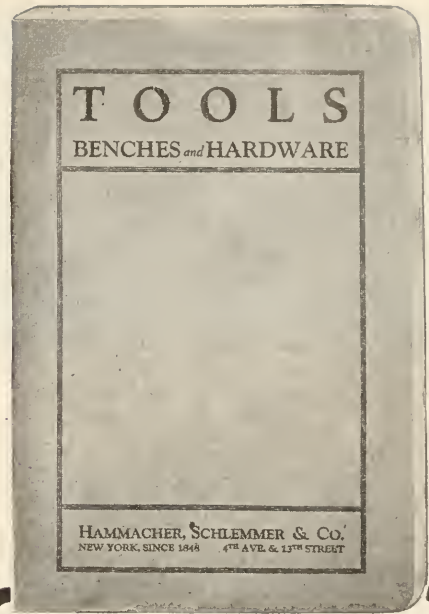

**GOOD TOOLS
ARE ESSENTIAL FOR
GOOD WORK**

Since 1848 we have adhered to one policy—to handle only the very best in quality.

Our 300 page catalog illustrated above is of particular value to those interested in manual or vocational training. If you haven't a copy ask for Catalog No. 224.

**HAMMACHER
SCHLEMMER & CO.**
Hardware, Tools and Supplies
New York, Since 1848, 4th Ave. and 13th St.



*Boyle Heights School,
Los Angeles, Cal.*

18

Buffalo Equipped

Buffalo equipped forge shops are rendering real service in schools and manufacturing plants throughout the world.

The experience gained by years of service and application are at your command to assist you in getting the most efficient forge shop layout to meet your particular requirements.

There is a Buffalo equipped forge shop in your vicinity.

*Write for Catalog
205-31 and list.*

Buffalo Forge Co.

BUFFALO

NEW YORK

“Buffalo”

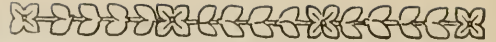

FIELD NOTES—(Continued)

machines, gifts from the Palmer Fund thru George Foster Peabody. The building trades are working on the Kennedy Dormitory for girls and the Teachers' Club House. By a gift of \$50,000, Albert F. Bemis, of Boston, has made it possible to offer an advanced course in house-building next autumn to graduates of the courses in carpentry and bricklaying and to others properly qualified.

JAMES FORBES, principal of the Vocational School at Southbridge, Mass., plans to equip a mechanical and scientific laboratory, in which experiments in casting lead, a cheaper substitute for iron, and the cutting of bevel, spiral, and spur gears will be conducted. Boys will also be given a knowledge of the strength and relative values, for certain purposes, of the different metals.

“WHETHER IT IS POSSIBLE to give a brief course in the history and development of industry, of raw materials, of routing and scheduling work, or waste elimination, time studies, wage systems and general problems of elementary economics, is a problem that should be solved by joint action of employers, workers, and industrial educators,” said William Baum, consulting engineer of the Holeproof and Everwear Hosiery Companies, in an address before the industrial teachers of Milwaukee on “Industrial Education and Production.” Mr. Baum sees in business efficiency the answer to low prices.

IN AN ADDRESS before the Sheet-metal Branch of the National Hardware Association, Mr. L. Broemel, of the Peck, Stow & Wilcox Co., Southington, Conn., pointed out the advantages of sheet-metal, compared with wood, as material for vocational courses. He said that sheet-metal is inexpensive, easily worked, fire-proof, serviceable, sanitary, that the machinery used is not dangerous, and that problems such as a Boy Scout camp mess outfit, a sheet-metal flower box, and many things of greater value, command the interest of the students.

BACKWARD PUPILS are taught cobbling, millinery and other trades in the ungraded classes of the John Goode School, Norfolk, Va. Miss Doris Wilcox, a practical psychologist, supervises the classes, assisted by nine special instructors. Elementary arithmetic is taught by “playing store;” the children make out credit slips and operate a cash register. In banking they use checks, deposit slips, and play money. Equipment is furnished by local firms.

THE NEXT MEETING of the Eastern Arts Association will be at Rochester, N. Y., in April or May, 1922.

THE BOYS' VOCATIONAL SCHOOL, Albany, N. Y., has been showing the work of 90 boys in the win-

Manual Training Magazine

AUGUST, 1921

THE EFFECT OF OVERCROWDING UPON INITIATIVE IN THE SCHOOL SHOP WILLIAM F. VROOM

THE school workshop offers a particularly favorable field for the development of self-reliance, good judgment and good taste on the part of the learner, qualities which, in any rational theory of education, are held to be wholly desirable and in greater or less degree attainable. The plan of allowing each individual in the class to select his own work, within limits, so that there may be choice of articles to be made, originality of design, selection in methods of construction and, in general, reliance upon the taste, inventive powers, knowledge and skill of the worker rather than upon ready-made plans and formal directions, seems to meet with general approval among educational leaders.

To illustrate: George is asked to think over what he would like to make, and report to the teacher before the next lesson. He reports, let us say, that he would like to make a medicine cabinet for his mother, and is eager to begin. Here we have a very laudable incentive and the correct attitude of the worker towards his work. You ask George now to make a sketch of the cabinet, giving dimensions, details of outline, construction and ornamentation. This is done. The first drawing is crude and unsatisfactory, for the boy is but an average pupil and has much to learn. A second drawing is made, and, after some further alterations and additions, we have a design pleasing in proportions, correct in construction and workable.

George must now make out a list of materials with dimensions etc. Having examined and corrected this you help him figure out the best way of cutting boards to avoid waste. He then proceeds to cut out the stock and is ready for the next step. You talk over the problem of making joints, some of which are quite new to the boy, and advise him to make a joint for practice before attempting it on his cabinet. You correct errors in this and urge the necessity of care and accuracy. You test surfaces, edges and angles and advise him if they are not satisfactory. You watch the progress of the work at every stage; advise as to obtaining the requisite stiffness and the true rectangular construction which is necessary to good work; give help in gluing up, instruction in the use of clamps and handscrews, in smoothing, scraping and sanding.

George will need much instruction also in setting hinges and locks or other fastenings, in putting in backs, paneling or glazing doors and in various other operations which he is attempting now for the first time. You will consult with him as to what kind of finish he would like and instruct him in the method of obtaining it. At length, as a result, the boy will be the proud possessor of a piece of work which he can feel is all his own. He will have grown in self-reliance and other virtues which it will be superfluous here to enumerate.

This is an ideal method of carrying on

the work of the school shop, and it will be encouraging to the advocates of progress in the educational field to know that much good work of this kind is being done. It is unfortunately true, however, that the conditions in many schools are such that a workshop program based upon the principle of individual initiative would be highly inadvisable, if not wholly impracticable. Such schools are those, for example, in which one teacher is responsible for the management of 15 to 18 classes per week, of 25 to 30 boys each.

Referring to the foregoing illustration it will be observed that the teacher advises, criticizes and instructs. Advises regarding things that are left to the boy's initiative, as dimensions, proportions, suitability to purpose, joining, finishing, ornamentation; criticises the work with a view to obtaining passable results, which the pupil lacks the skill and judgment to accomplish unaided; instructs in various details of the trade which are understood only by skilled workmen and in which the boy has had no previous instruction. So it is evident that the teacher has been at George's elbow much of the time, notwithstanding the fact that the boy has depended on himself as far as due consideration for creditable results would allow. Now, multiply George and his project by thirty—thirty *different* projects, remember, (not to mention the thirty different boys)—and imagine how much of the teacher's time each individual could have had.

If every pupil is free to choose his own work and exercise his own taste and judgment under advice, criticism and instruction, how many will the average teacher be able to take care of?—for we must bear in mind that both George and his teacher are *average*; neither is a soaring genius nor a hopeless numskull. No hard and fast rule can be laid down on this

point, since conditions vary so greatly, but with conditions such as are frequently found in our public schools, and such work in hand as our hypothetical sketch indicates, I should say that a class of ten would be as large as one teacher should undertake to handle.

In order to arrive at a fair estimate of the situation it may be well to review here briefly a certain popular misconception. Many persons, while they know that not all public school boys are angelic in disposition and conduct or endowed with a spirit of indomitable industry in the study of grammar and arithmetic, yet believe that a certain magical influence which pervades the workshop will keep them always happily employed and out of mischief. "There is no problem of discipline in the workshop," they say. There are many schools where this is true, but they are not the schools where thirty pupils swarm into the shop as thirty others swarm out three or four times a day for five days in the week—the schools, that is to say, where one teacher has to deal with 450 to 500 boys.

It is not true that all boys like the work. Many boys like to use tools in their own way—like to play with them rather than work with them. They like to do childish work, such as cutting a piece of wood into a shape that they fancy bears some resemblance to a boat, a pistol or a knife, and that without rule, line or measurement; but when it comes to careful, methodical laying out and cutting to lines on a serious piece of work their thoughts go to the base-ball field, while saw and chisel move with laggard strokes. It is not true, furthermore, that all boys have something to do all the time, and it is not true that all who have something to do keep at it with untiring persistence.

In the workshop the boy is not, as a rule, prevented from talking and moving about, and if you give him an inch he will take

an ell. In the shop the necessity of making rules and giving orders and directions is much greater than in other rooms, which means that there are more opportunities for disobedience. Then it should be remembered that there are frequent occasions when the class is lined up before the demonstration bench for a lesson, and there is no more reason why they should not use their prerogative of making the teacher's life miserable there than in the classroom. The teacher must have his eyes on his work much of the time, and that gives them a fine opportunity. And then there are so many conveniences in the workshop for making a variety of noises! These are a few of the facts about the overcrowded workshop that the outsider does not generally realize. It is easy to say that it is the teacher's fault if the pupils are not kept interested etc. This is a good enough criticism in a general way, but obviously its application is limited. Many successful teachers and excellent disciplinarians will endorse my statement as to the relative difficulty in keeping order in a large class as between the classroom and the workshop.

Let us suppose that a line of elective work is undertaken in grade 8B, that we have 120 pupils in that grade, and that each class has two consecutive shop periods per week. Then, if classes were limited to ten, we should require twelve double periods in the week to accommodate 8B alone. Instead of twelve many schools allow four at most. The outcome of this is not unlikely to be a well developed Bedlam in the workshop, with the inevitable material results.

But I may be reminded here of certain considerations that I seem to have left out of account. Have we not seen excellent work done in the 7th year, it may be asked, and done in large classes at that? Why then should we not expect

good work from 8B pupils, who have done so well in previous grades and have had the advantage of so much training and experience?

Unquestionably much good work is done in the 7th year, work so good that it is surprising to the observer from outside. But how is it obtained? *By the strictest kind of drill.* It is class instruction, pure and simple, and demands the suppression rather than the encouragement of initiative. One step at a time is explained and illustrated, and the pupil is warned against the mistakes commonly made by beginners. This step is carried out at the bench, the next step given out and so on. It may be mentioned here that it is not evidence of acquired skill that you see in the work of 7th year pupils (tho that some degree of skill has been acquired is undeniable), it is rather evidence of carefulness. The natural, instinctive carefulness of the boy of thirteen? By no means. It is the carefulness exacted by the illustrations, exhortations and insistence of the skillful teacher. It is not my purpose here to discuss the pedagogical aspect of this method, but it is the only method possible for large classes. By large classes I mean classes of 25 to 30 or more for one teacher, or 45 to 50 or more where an assistant is employed. To relax the restraint would result in a waste of time and material and open the door to habits of slovenly work and disorderly conduct.

Admitting then the necessity of systematic class instruction in the lower grades, does it follow that the same methods must be maintained in 8B? The pupils have learned to handle tools and to do good work. May they not now be trusted to apply their knowledge and experience on models of their own selection with such help as the instructor can give them individually? Let us see.

Suppose each class has 19 shop periods

in a term—and it will not be difficult to find classes getting less than that when deductions are made for holidays, field days, examinations, fire-drill and other interruptions—and that such periods are of 80 minutes duration. Of this time at least five minutes is lost in marching from room to room, putting away tools and work and getting in line for dismissal. Deducting again time for sharpening tools and instruction other than that necessary for the work in hand, we have considerably under an hour and a quarter per week for the actual work and the instruction for doing it. A simple calculation then will show that the pupil has less than 24 hours in the school term, or less than six eight-hour days in a year for instruction and practice, which is *less than two per cent* of the time an apprentice would be employed in an industrial concern. How much knowledge and skill in handling a dozen different tools and working out a hundred different processes is it reasonable to expect a boy to acquire in a term, that is to say, in three days?

As a matter of fact the average boy gets very little. While he is held as with bit and bridle and knows that his work will be inspected and rated by the teacher he will do fairly well, but the moment the centripetal force is removed he goes off on a tangent. He has no use for geometrical restraints, well fitted joints, smooth surfaces or any other workmanlike qualities. His ambition is not to do the thing *well*, but to do it *now*, (and who can say that the boy is altogether responsible for that?) He does not remember all he has been taught, and does not make practical application of all he remembers. He lacks patience, does not appreciate the necessity of accuracy, does not comprehend the principles of mechanical construction. And why should we wonder at all this? Does he not exhibit the same imperfections in the study of arith-

metic and grammar? These, then, are the facts, little as we may like them. No boy now-a-days comes into the world like Pallas of old, fully equipped and needing neither instruction nor practice.

When we consider that not more than 20 per cent of the three days—that is, four hours in each school term—is given to direct instruction we should not be surprised that the pupil has assimilated so little, and remembering that only the remaining 80 per cent, or less than 20 hours, is given to the actual handling of tools, we should not look for any wonderful development of skill. But the amount of instruction he has received and failed to profit by is inconsiderable compared to that which he has never received. A boy who was the proud maker of a piece of furniture which was an object of high praise and admiration when on exhibition, made a small box having a cover to be fitted with lock and hinges. He worked without instruction. The cover did not fit, the hinges were awry, the screws split the wood and the lock did not work. That cover was discarded and another was made. The setting of lock and hinges was again attempted without instruction and the result was as bad as before. Why? Simply because these operations are not matters of instinct or intuition, but are well defined processes of the trade, and the boy did not understand them. They have been handed down from artisan to apprentice for generations past and will be for generations to come. And so it is with numberless other operations in the trade of the cabinet maker or any other trade.

A brief consideration of the attempt to carry on a class of 30 boys under one teacher, each boy undertaking an ambitious project of his own initiative, will serve further to show the reasonableness of my contention. Suppose that the articles to be made are not of large di-

mensions nor of elaborate design or construction—such as taborets, footstools, small cabinets and the like—and each different from all the rest. The boys have had a maximum of 24 hours' workshop instruction and practice in each term. Those who have had three terms will have had no more, probably less, than 15 hours' instruction and 57 hours' practice, all told. Consider that these thirty boys in these three terms (seven days' work) have never made a mortise and tenon joint nor a dovetail joint nor a miter joint, and do not know how, where and why these and many other joints are used; that they have never set a lock nor a hinge nor a pane of glass; have never applied wood filler nor paint nor varnish; have seldom or never used handscrews or clamps or any of the countless tools outside of the small kit in their benches; have never assembled a piece of work of any importance; then consider how little instruction the most competent teacher can give during the fifteen minutes at his disposal, and how little of what they have received they are likely to retain, and how little skill they can possibly have acquired in the time they have had for practice—consider all these points, which are but a fractional part of what might be enumerated, and you will have some faint notion as to what may be expected from the student's initiative in a class of thirty.

I say "faint notion" advisedly, for there are yet many factors to be mentioned which contribute to the determination of results. In the first place, the class is always ungraded as to proficiency in shopwork. Big boys and small boys may compete on equal terms in grammar or history, but not so in the workshop, where physical strength counts for much. Boys of the same class may be fairly abreast in arithmetic, but as far apart as the poles in mechanical ability. Un-

graded classes are not tolerated in other departments, but the workshop must take what comes. This is a serious hindrance.

Another effect of large classes and many of them is to lower the efficiency of the tools. The careful and capable worker with a good piece of work in hand will be much hindered by the necessity of using tools that have been used by fifteen other boys during the week.

In general, numbers tend to confusion. The more boys the more noise. That is axiomatic. Much of the noise, of course, is necessary. It is the "hum of industry." But legitimate noise and legitimate movement furnish a shield for the noise and movement of play and turmoil. Any teacher can maintain good work and exemplary conduct in a class of a half dozen boys. Increase the number by degrees and you will find a corresponding deterioration in the quality of the work and the tone of the class. To continue the expansion is to hasten the deterioration until the inevitable limit is reached, tho you have exactly the same kind of boys at the end of the experiment as you had at the beginning.

The teacher who has to divide his time among 30 boys will be able to give each about two and a half minutes out of the regular weekly allowance of seventy-five—provided he is not obliged to spend a part or the whole of that time on something else, such as the preservation of some semblance of order, the inspection of damaged tools or other equipment, assistance in the use of unfamiliar tools, jigs and devices, not to mention the numerous unforeseen interruptions which may occur in the best regulated shops.

Seeing then how much the average pupil needs of advice, criticism and instruction and about how much he stands a chance of getting in a class of thirty, what may we expect as the inevitable result? Ten per cent of the class—those

of exceptional ability — may produce really creditable pieces of work; forty per cent of the articles made will be fair, and thirty per cent poor—of a quality distinctly inferior to work done by the same boys in the 7th year, while the remaining twenty per cent of the class either abandon the job entirely or produce such a worthless article that they are ashamed to take it home.

In the meantime various things are taking place: 1. Much lumber is wasted in getting out stock for the model. Since all models are different the teacher can give only general rules for this operation, and these are largely misunderstood or unheeded. 2. Much waste results from careless and slipshod work. Parts are destroyed and thrown away and new pieces are cut out to replace them. And this is generally done surreptitiously in the hope that the teacher will not observe it. 3. Many boys who have begun with enthusiasm are soon discouraged. They have neither the skill nor the knowledge necessary to do the class of work they have undertaken. They may have had their share of the teacher's attention—two and a half minutes per week—but somehow it has not enabled them to overcome their difficulties, so they either plod along aimlessly and hopelessly and get some sort of nondescript thing put together, or they give up altogether and devote the rest of their time to dodging the teacher and having as good a time as they can. 4. Better disposed boys will frankly admit that they cannot do

the work and will ask the teacher for something else to do. Of course the teacher cannot attend to them without robbing some other boys of their two and a half minutes per week. 5. The teacher, if he really cares for the welfare of his class, is at his wits' end. He wants to see good work, but he sees the utter impossibility of getting it. He wants to maintain good order, but he sees the hopelessness of accomplishing that without keeping every pupil busy and interested or giving all his time to discipline. He cannot keep them all busy, because that would take much more than two and a half minutes per week each, and he cannot give his time to disciplinary matters without depriving those who need it of his help. Such is his dilemma. In the endeavor to strike a middle course he gets neither good work, which is out of the question in any case, nor good order, which is perhaps equally out of the question. He sees the good work of 7A, 7B and 8A, of which he has been justly proud, followed by slopwork in 8B, the good order of those grades giving way to confusion, disorder and loafing, and the enthusiasm of some boys for shopwork turned into indifference or dislike.

Let us encourage initiative by all means where conditions are favorable, but the right conditions do not exist in the school where there are five hundred pupils under one teacher—much less where there are eight hundred under two teachers in one room.

The common school is the greatest discovery ever made by man. Other social organizations are curative and remedial; this is a preventive and an antidote.

—HORACE MANN.

CANDLE MAKING—AN INDUSTRIAL ARTS PROBLEM FOR THE ELEMENTARY SCHOOL

L. A. HERR

Supervisor Elementary Industrial Arts
The Lincoln School of Teachers College, New York City

IF THE question "Why make candles in modern schools?" is asked, we reply that the making of candles at some time during the first six years of school may be justified in many ways. To sit for an hour in the dim glow of a candle which one has made himself and to contemplate the history of candles will do much to bring a real feeling for the pioneer days. In the history of modern lighting, candles hold a very important place. A candle of certain specifications is still used as a measure for the intensity of light. The custom of burning candles at Christmas time, and on other festal occasions, and their present daily use in many churches, homes and factories are reminders that the candle continues to be a factor in modern life.

The processes necessary in making candles appeal to the construction interests of children. The equipment required is very simple, and the materials inexpensive. Further, the processes are of such character that one lesson, or a series of lessons, may profitably be allotted to the work. The class procedure may be adapted to the ability of any grade. A small dipped candle can be made by the first grade child; to make one of large size, or to perform the operations necessary for successful molding, will present sufficient difficulties for the sixth grade pupil. It is believed that any teacher who will follow the suggestions contained in this brief article will be able to direct a class in candle-making with reasonable success.

A candle consists of a cylinder of solid fat or wax containing a central wick. The latter thru capillary action admits of the

absorption and ascent of the surrounding matter to the flame where it is heated and then burned. The size of the wick must be adjusted to the diameter of the candle and the fusibility of the material. The flame should be just large enough to burn all the fluid as it melts. If the wick is too big, no cup will be formed at its base and guttering ensues. If it is too small, the matter forming the rim of the candle does not melt uniformly with the descent of the flame, and the results are equally unsatisfactory. The exact adjustment, however, must be left to the experimental laboratory of the commercial manufacturer, a rough approximation being sufficient for our purposes. Candle wicking is made of cotton. Commercial manufacturers buy their wicking material in hanks of required sizes of thread, and make such adjustments as to the number of threads and their manner of combination, as the requirements of the candle demand. For school work, balls of wicking, costing about ten cents each, may be secured from dealers in school supplies.¹ One ball will supply material sufficient for several classes.

MATERIALS

Many kinds of waxes and fats are used in the manufacture of commercial candles. We shall consider four of these:

(1) *Tallow*: This is obtained from fat from the regions of the loins and kidneys of beef and mutton, and is made ready for use by rendering and clarifying. In rendering, the suet is cut into small pieces and heated. As soon as the fat melts, it is strained from the remaining

1. Milton Bradley Co., New York.

matter (called cracklings). The mere melting and straining of the tallow does not entirely free it of fine undissolved substances, so that further clarifying becomes necessary. This is done by remelting the tallow on water. Five per cent of water is stirred well with the tallow, till the mixture forms an emulsion. It is then allowed to cool without further heating, and is ready for use. The tallow of mutton is harder and whiter than that of beef, and is, therefore, more desirable for candle making. Four pounds of suet will produce enough tallow to supply a class of thirty pupils. Tallow was the material used before the period of the oil lamp by the people of the middle classes in making their candles for daily use.

(2) *Beeswax*: This is obtained by subjecting honeycombs to heat and pressure. The wax thus obtained is melted in boiling water to free it from remaining honey and other impurities. The prepared wax may be purchased from the druggist at a cost of about one dollar per pound. Four pounds will be sufficient to make thirty candles of medium size. This was the candle material of the wealthy in primitive times. It is now commonly used in making candles for use in religious ceremonies.

(3) *Bayberry or Myrtle Wax*: This is a greenish, bitter-tasting, aromatic wax obtained from the berries of the bayberry shrub found along Lake Erie, the Atlantic coast and elsewhere. The ripe berries are boiled in water three or more hours. The wax rises to the surface and is skimmed off and put in shallow vessels. Eight to ten pounds of berries will yield about two pounds of wax. This wax is used principally for making hand-dipped candles. The prepared wax may be secured from dealers in wax supplies and from druggists² at a cost of about 55 cents per

pound. Two pounds will be sufficient for a class of thirty pupils.

(4) *Paraffin*: This is a crude petroleum product. In burning, it has greater illuminating power than the materials mentioned above, and no disagreeable odor. This material has almost wholly superseded the use of tallow in the manufacture of commercial candles. It may be purchased of grocers in prepared cakes at a cost of about 23 cents per pound. Stearic acid, to the amount of five per cent should be added to prevent candles made of this wax from becoming plastic in warm atmospheres.

METHODS OF MAKING

Candles may be made either by dipping or by molding. In the latter method, the melted material is poured into molds which retain it in the appropriate shape while it hardens.

Dipped candles are made by successively dipping the wick into the melted wax. A layer or coating of wax adheres to the wick at each successive dipping. The dipping is continued until a candle of the required size is formed.

Molded Candles: As a preliminary step, the molds for each candle, Fig. 1, should be tested separately for leakage by filling them with hot water. Sometimes new molds contain leaky forms. If such are found, their tops should be closed with cork or rubber stoppers, leaving the perfect molds only to be threaded with wicking and to be filled with the melted material. All the water should be removed from the molds after making such test. The wicking to be used should first be dipped into the melting candle stock before it is inserted in the molds. The upper end of the wick is then secured to a small stick long enough to reach across the top of the mold. Or, if a stick equal in width to the distance between centers of two parallel rows of candle molds,

2. F. A. Bromund, 356 Broadway, New York, Wax supplies. Sisson Drug Co., Hartford, Conn.

(see stick on candle mold, Fig. 1) is selected, the wicks for each two adjacent candles may be looped over such stick, thus avoiding tying the wicks at the upper end. The wicks must next be drawn down into the molds and the free ends brought thru the small holes which will form the

also to seal up the hole so that none of the melted material will escape when the molds are being filled. Since the latter point is extremely important, it may be well to mention other precautions. A piece of rubber elastic tied into the knots helps to make a closed seal. The tips of



FIG. 1

tips of the candles at the bottom. A long loop of very fine wire inserted from the under side of the mold is very useful for this purpose. If this is not available, a needle or pin, or a loop of thread may be used to bring the ends of the wicks thru the bottoms of the molds. These ends must then be fastened. In the early days this was done by inserting pegs in the tips of the molds, or by tying knots in the wicking. The latter method will be found more satisfactory, as a candle with a perfectly shaped tip cannot be formed if pegs are used. The purpose of the knot or peg is to hold the wick so that it will remain in the center of the mold, and

the molds may be pressed into a bed of fine sand, wet with cold water. This will force the knots against the tips of the molds, and it will at the same time keep the molds cold, thus hastening the cooling of the candles at this point. A very few drops of the melted material may be placed into the molds and time allowed for this to cool before the molds are completely filled.

Of the materials mentioned above, tallow and paraffin only are suitable for making molded candles. Waxes, because of shrinkage in cooling, are unsatisfactory for molded work. Tallow is the easier material to use, and is also more

typical of the work of our ancestors. After being melted, it should be allowed to cool until it shows evidences of hardening at the edges of the container. The molds



FIG. 2

should then be filled, and some surplus tallow left in the pan-like tray at the top. This surplus fills the centers of the molds, thus preventing hollows in the bases of the candles. Care should be taken to have each wick exactly in the center of its mold, before the work is set aside to cool. Four or five hours should be given for the candles to harden. They may then be removed from the molds in the following manner: Cut the wicks so as to remove the sticks. With a putty knife, or any similar instrument remove all the tallow from the tray and trim the bases of the candles flush with the bottom of the tray. Do not cut the wicks off flush as they are

needed in pulling the candles from the molds. Cut off the knots at the tips of the candles. Pour hot water over the molds, or immerse them for an instant in hot water, to loosen the candles. Remove the candles from the molds by pulling them in a *vertical* direction, Figs. 2 and 3. If paraffin is used, the molds must be heated to a temperature slightly above the melting point of the paraffin before the molds are filled. If this is not done, the candles will be streaked and unsatisfactory in appearance. The cooling for paraffin candles must be rapid. This can be accomplished by immersing the mold into very cold water. If paraffin is allowed to cool slowly, it will adhere to, instead of becoming free from the sides of the mold, and the candles will be injured as they are pulled from the molds.



FIG. 3

Colored candles may be made by using colored material; or they may have the color on the outside only, the interior being of plain or uncolored material. The method employed in making candles of the latter kind is first to fill the molds with colored paraffin. As soon as it has hardened on the outside, the liquid interior is poured out, and the cavity re-filled with the uncolored material. This process is somewhat complicated for beginners. The tallow or paraffin to be used



FIG. 4

in candle making may be melted in any convenient pan. One with a lip to facilitate pouring is desirable. A large stirring spoon is also useful for dropping a small amount of the melted material into the molds to test the knots for leakage, and for use in removing the surplus material from the tops of the molds before the candles are drawn from them. Particular care should be taken not to continue to heat the paraffin after it has been melted as this material is highly inflammable. Should it begin to burn, however, the blaze may be extinguished by slipping a cover over the pan so as to exclude the air, or sand may be thrown into the pan to choke out the flame. Do not attempt to use water to extinguish a blaze of burning wax or fat, as the fire would be scattered by so doing.

Hand Dipped Candles: Any of the materials listed above may be used in making dipped candles. Bayberry wax, beeswax, and paraffin will give more satisfactory results, and candles can be made of these materials more readily than of tallow.

The first step consists in the preparation of the wick, Fig. 4. This varies with the material to be used. In general, the more easily melted and combustible the material, the looser should be the wick. A tightly twisted or plaited wick is unsuited for tallow candles. For bayberry wax or paraffin, cut the wicking into lengths equal to twice the proposed length of the candles plus six inches for end trimming. These pieces of loosely twisted wicking may be easily separated into a number of smaller strands.³ For a candle of less than five inches in length use three of the small strands. For larger sizes use four.

In preparing the wicks from the selected strands pupils can best work in groups of two. Each pupil should then take an end of the parallel strands, the two twisting in opposite directions until the one twisted strand thus formed tends to kink. The strand should then be doubled, one pupil holding the folded end, the other the two loose ends. Care should be taken not to let go at either end as the strand would

3. The Milton Bradley wicking contains six such strands.

at once untwist or twist about itself. The two pupils then twist in the direction opposite to that taken in the initial twisting. Continue this twisting a little more than seems necessary as there will be a slight loosening of the wick when the



FIG. 5

ends are released. By following this procedure a smooth, tightly twisted wick will be obtained. If the strands are allowed to twist immediately after the first twisting and doubling a more loosely formed and less satisfactory wick results. An equal amount of material may be braided, the object, as in the preceding case, being to produce a firm and smooth wick. A wire should be bent to form a hook at each end. One of these hooks should then be inserted thru the folded end of the wick. This is used as a handle in the dipping. The remaining hook is useful for suspending the candle while the

wax is hardening. A convenient hook for this purpose may be made by partly straightening the commonly used Gem paper clip, or hairpins may be secured for the purpose. The latter make longer and more desirable handles. Altho successful results may be secured in other ways, the danger of having bent or crooked candles can be met by attaching a small weight to the bottom of each wick, after the manner of attaching a sinker to a fishing line. A nut from a small bolt or any other small iron object will answer well. In schools having a workshop a loan of such articles can usually be secured. After the work of making the candles is completed, the wax should be melted from these leaving them uninjured. If no weight is used, care must be taken to see that the wick remains straight in the first dipplings. Each pupil should write his name on a small strip of stiff paper, and put it on the wire dipping hook. This will save confusion in identifying the work, and if the strip is small, it will in no way interfere with the dipping process. For short candles such as would be suitable for pupils of the first and second grades to make, both the weight and the wire hook could be omitted.

Any receptacle large enough may be used to contain the wax into which the wicks are dipped. In the early days a trough was commonly used, the wick entering and coming out of the trough containing the wax by a side movement. For school work, several smaller receptacles, each arranged for a small group of pupils is more desirable. The receptacle must always have a depth greater than the proposed length of the candle. For short candles, baking power cans, or tin fruit cans may be used. For longer candles, tall, wide-mouthed bottles, such as olive or honey bottles or candy jars, may be obtained. The ever present danger of breaking a glass receptacle,

makes a metal container more desirable. The writer improvised a long tube by combining two aluminum clothes sprinklers, Fig. 4. These have screw covers. The top of one of these covers was cut out and the remaining threaded portion used as a collar to hold together the threaded ends of the two tubes, thus mak-

cumulate enough wax to hold the wick rigid, after which further straightening should not be necessary. If the arrangement of the room permits, pupils can hold their work near open windows to hasten the cooling. Strips of wood may be nailed across the windows on the inside so that pupils using the wire dipping

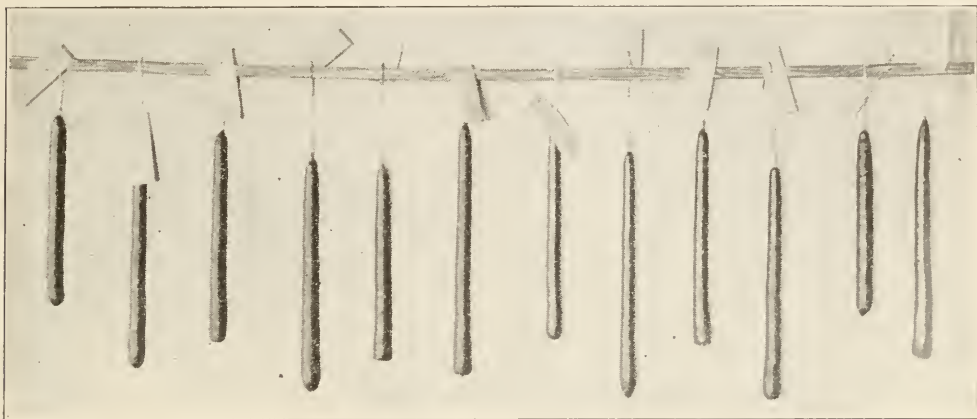

FIG. 6

ing one long tube. The bottom of the inverted tube was then cut out to make the upper opening. A hole having a diameter equal to the aluminum tube was bored thru a piece of board, and the tube pushed partly thru it. This helped very much in handling this long tube and in securing it in position while in use.

The technic of dipping is as follows: The receptacle into which the dipping is to be done is first filled with the melted material. The wick, held at the end that is to be at the top of the candle, is then immersed in the material and at once withdrawn, Fig. 5. A coating of wax will adhere to the wick as it leaves the liquid. This coating coming in contact with the air soon hardens and stiffens the wick. If the wick contains any kinks or bends these must be removed at this stage of the work. If a weight has been used it will serve to keep the wick pulled straight. One or two dippings will ac-

cumulate enough wax to hold the wick rigid, after which further straightening should not be necessary. If the arrangement of the room permits, pupils can hold their work near open windows to hasten the cooling. Strips of wood may be nailed across the windows on the inside so that pupils using the wire dipping

hooks can hang up their work after each successive dipping, Fig. 6. An old yardstick, or a shade stick temporarily removed from a shade for this purpose could be used. The dipping is continued until a candle of the desired thickness is formed. As the wax becomes cooler the amount adhering to the wick increases, so that the candles grow much more rapidly at the close than at the beginning of the process.

Instead of completely filling the chosen receptacle with wax, the same result can be secured by floating a thin layer of wax on hot water, Fig. 7. Since the wax adheres to the wick only as it leaves the liquid, the result is the same. Of course, if a thin layer of wax is used, the container will need to be replenished more frequently. This procedure makes it possible to utilize almost all of the available wax in actual candle making. It also makes practical the use of tall re-

ceptacles of greater volume than those suggested above, such as gallon pails, or cans used for holding paints or oils. The rectangular can shown in the illustration, Fig. 5, is an old varnish can with the top cut off.

Certain precautions should be taken in the dipping. A well-shaped candle is about as thick at the upper end as it is at the lower. In the best hand-made candles there is a slight taper, much as one sees in the trunk of a tree, or in a well-shaped finger. The wick at the end to be lighted should protrude, clean and free of wax, a fraction of an inch above the top of the candle. These results are obtained in the hand-dipped candle, (1) by dipping the wick exactly to the same depth each time. If a quarter-inch of clean wick is to protrude above the wax, then the wick must be so dipped each time that the bottom of the wire hook is that far from the top surface of the wax. Do not dip into a vessel of too shallow depth, or into one from which so much of the wax has been used, that the required depth of immersion is impossible. (2) The dipping should be speedy, and the cooling between succeeding dips complete. If the wick is not promptly withdrawn from the melted material, the wax already accumulated may be softened or actually melted off. When several pupils dip into the same receptacle, two dips in succession—at most three—and then thoro cooling should be the order. If several pupils are working, pupil number one dips, passes to a window and hangs his candle to cool, allowing it to remain until the other pupils have had their turn. Then number one makes a second dip, the others following in order.

For coloring hand-dipped candles, two methods are possible, to color all the material used in making the candle, or to color a small amount to be reserved for use on the outer surface in the final dip-

ping. If the latter method is used less color will be required. Mineral colors should be avoided as these interfere with combustion. Aniline dyes—in fact any animal or vegetable coloring matter that is found to combine readily with the

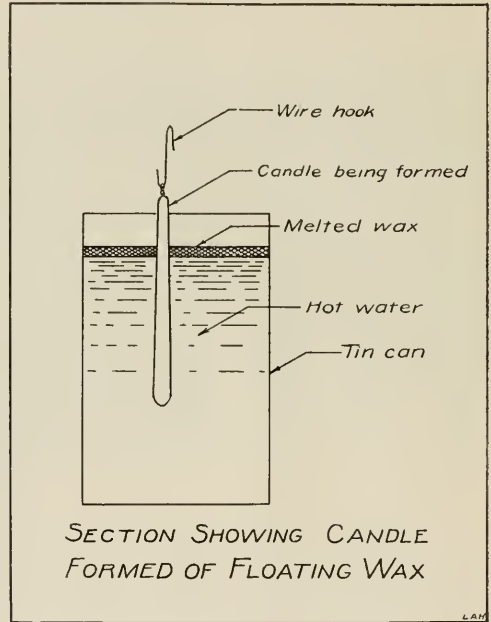

FIG. 7

candle material may be used. Wax crayons⁵ may be easily melted, and the wax thus secured combines well with paraffin. One or two sticks will furnish sufficient color for two dozen large candles. To prepare the crayons the paper should first be removed from the outside. They may then be melted as any other wax. A sufficient quantity of the color thus obtained to give the desired tint to the candles can then be added to the receptacle containing the plain material.

Occasionally an accident occurs. A candle that has required an hour of patient work to build up may be broken. To mend such candles, cut with a knife a V-shaped opening, enlarging the crack with the base of the V at the wick. Lay

5. Binney and Smith Co., New York, crayolas.

the candle on its side taking care to have it straight. Then with a spoon drop wax, a little at a time, into the opening. By working carefully, putting the wax just where it is needed, the cut can be filled. It should be filled somewhat in excess of the original contour. Then carefully turn the candle over and cut a similar notch on the opposite side and fill in the same way. With the knife pare off the extra wax around the mended place. Then give the whole candle one complete dipping in the wax. If a candle is too large at one end, it may be reduced by dipping it into hot water until some of the wax is melted off. The final step in completing a dipped candle consists in cutting off the end containing the weight. To do this lay the candle on several thicknesses of paper to prevent marring its side and saw off the end with a back saw. If a saw is not available use a knife, cutting first a line completely around the candle. Below this cut, make a slanting cut so as to remove a V-shaped ring around the candle. Continue these two cuts until the wick is reached and severed. If no weight has been used the end may be squared by cutting off the base, using either of these methods.

The result most evident in a candle-making lesson is the joy that comes with successful accomplishment. For little children this has a special significance. In the making of other articles by them much assistance must be secured from teachers and the product when completed is somewhat crude. In making candles, the pupil may do all the work from the initial measuring and cutting of the wick into suitable lengths to the final dipping. The finished product need be in no way inferior to a similar commercial article. The pleasure of presenting a

well-made article to his mother, to a friend, or of offering it for sale in a school bazaar is therefore much enhanced. The fact that the results are obtained in comparatively few lessons, adds to the pleasure derived from the work. The range of new ideas concretely demonstrated is also great. For example: the first grade pupil may realize for the first time the effects of heat and cold in changing wax from a solid to a liquid. The pupil in the fifth or sixth grade may obtain his first concrete impression of how materials are shaped thru the general process of casting in molds.

Many questions relating to the history of modern and early candle-making may be expected from the pupils; questions pertaining to sources of the raw materials, to the physics and chemistry involved in the making and burning of candles may be raised by older pupils. The making of candle sticks of clay, wood, or metal and of candle shades, might be undertaken. In many schools these articles are often constructed as a part of the work in fine arts. An opportunity for co-operation between the fine arts and industrial arts is thus afforded. Additional construction work might be suggested, such as the making of molds and the casting of articles in metal, plaster, or concrete. In this way a beginning will be made toward an understanding and appreciation of the production of the large and varied range of metal, clay, and concrete articles produced by casting processes. From this it may be seen that a great amount of related work may be an outcome of a few lessons in candle-making. Each class will doubtless display different interests, and these may be met by variations in conducting the work.

EDITORIAL REVIEW FOR THE MONTH

A UNIQUE SCHOOL FACTORY IN DES MOINES

I WAS in and out of Des Moines during the National Education Association meeting, July 3-8. During the week I made three observations: (1) Iowa is a competitor of Illinois in raising corn because she has weather that is just as hot and humid as Illinois. (2) The

appointment, R. C. Woolman, director of industrial education, whose far-sightedness and practical energy are the cause for this exceptional shop. On entering I realized immediately that I was in a furniture factory. There were truck loads of pieces of wood in all stages of manufacture; there were partially assembled supply cases and teachers' desks



FOUR OF THE FIFTY FILING CABINETS MADE OF BLACK WALNUT IN THE SCHOOL FACTORY, DES MOINES, IA.

Department of Vocational Education of the N. E. A. is not as well attended as it deserves to be—too many people are busy in summer schools during July. (3) The city of Des Moines has the largest and most completely equipped woodworking factory that I have ever seen in a public school. It is a real furniture factory, and it runs twelve months in the year—ten months with junior high school pupils, for it is in the Washington Irving Junior High School building—and two months with manual training teachers and a few selected pupils. It is concerning the work of these two months that I wish to write a few paragraphs.

I went to the school and met, on

in groups on the floor; there was the odor of black walnut shavings; there was the characteristic hum of an efficient factory; and there were men and a few boys working at the various machines. Among the machines I noticed several I had never or seldom seen before in a school shop; for example, a planer, matcher and moulder, a glue jointer, and a three-drum sander. Besides these, there was a chain mortiser, a hollow chisel mortiser, two belt sanders, two surfacers, several saw tables, etc. This factory was turning out a superior grade of school furniture for less than the market price by giving summer employment to the manual training teachers and a few boys at good wages.

But what interested me most was not the completeness of the equipment, nor the excellence of the furniture, nor the fact that manual training teachers are good mechanics, nor yet that a shop can be managed in such a way as to pay good wages. I was interested in what seemed to me to be the bigger facts of the scheme as presented by Mr. Woolman. I am confident I am revealing no secret when I say that fundamentally this summer factory scheme is not only an economic one, but an educational one. In the first place it strengthens the unity of the department. When thirteen out of eighteen men on the staff are working happily and profitably for six or eight weeks in the summer in close touch with their supervisor in rendering real service to the schools, a departmental spirit is sure to be developed. Such experience also increases their practical knowledge and skill and raises their standard of workmanship. This is Mr. Woolman's way of meeting the common criticism that manual training teachers are lacking in practical trade experience and in knowledge of the economics of production. The effect, of course, does not stop with the teacher but is passed on to the pupils during the following years.

As would be expected, such a successful factory scheme has not developed in a day. It has been developing thru years. It started several years ago with a very meagre equipment—a twelve-inch jointer, and a precision saw with a mortising attachment. Then a belt sander was built in the school and added to the equipment. Later, came the new shop of ample proportions, and year by year the additional machines. Every expenditure has been justified in the minds of teachers, school officials and citizens. Steady, efficient management in the spirit of public service has made the present results possible.

PROFESSOR VAUGHN BECOMES
PRESIDENT OF HARDIN COLLEGE.

AS USUAL the summer month bring announcements of promotions and changes of position of men who have been leaders in the field of industrial education. One of the surprises this year is the announcement that Professor



S. J. VAUGHN

S. J. Vaughn is leaving the University of Illinois to accept the presidency of Hardin College at Mexico, Missouri. Hardin College is a junior college for young women. Its usual enrollment is about 225. There is a faculty of about thirty. The college has a permanent endowment of something more than \$100,000, and a building fund of about \$225,000 available this year.

In a recent letter Mr. Vaughn expresses regret at leaving the University of Illinois and the state. He says he is not leaving the field of vocational education, and adds, (and I cannot resist the temptation to quote his exact words) "For my part, I am going because the administrative feature of the position appeals to me, having had charge of a

private school in Missouri at one time. Further more, I am being exceedingly well paid (for me.) And I have always threatened Missouri with a return. I used to say that I wanted finally to be



ROYAL B. FARNUM

buried in Missouri, and some of my friends who do not know Hardin College, have intimated that I have accomplished this feat. But I'm determined to make it a most lively occasion. The prospects at Hardin resemble anything else in the world but a funeral."

Mexico is now added to our map of Missouri.

ROYAL BAILEY FARNUM GOES
• TO MASSACHUSETTS

A HIGH honor has come to Royal Bailey Farnum, president of Rochester Athenaeum and Mechanics Institute of Rochester, N. Y. He has recently been elected principal of the Massachusetts Normal Art School and director of art education in the state of Massachusetts. He has been called back to his alma mater. Probably there is no more important position in this country in the field of public art education. The Massachusetts Normal Art School is the parent institution in its field, has a most honorable record, and a bright outlook

for the future. The history of public school art education in America is, to a very large extent, made up of the acts of the alumni of this school. Mr. Farnum's record would indicate that he is just the kind of leader to enable the school to fully maintain this record in the future.

Shortly after graduation from the art school Mr. Farnum went to the Cleveland School of Art and organized the normal department, at the same time doing some part-time teaching in the Central High School of that city. After a little more than three years in Cleveland he went to the New York State Education Department as a specialist in drawing and industrial training. He remained in this work for nine years. In 1918 he became director of the school of art at the Mechanics Institute, Rochester, and the following year was made president of that Institution.

We shall look to see art have still more influence upon industry in the State of Massachusetts.

CHARLES H. WINSLOW GOES
TO PHILADELPHIA

C HARLES H. WINSLOW has been appointed secretary of the Pennsylvania Museum and School of Industrial Arts, Philadelphia. He will begin his work at the school on September 1st.

In the minds of many persons this school is always connected with the name of Leslie W. Miller, who held the double position of principal of the school and secretary of the trustees for many years. Soon after Mr. Miller's resignation, about a year ago, Huger Elliott of the Museum of Fine Arts, Boston, was made principal of the school. Now Mr. Winslow has been made secretary of the trustees and it is reported that a part of his work will be to bring about closer co-operation between the Museum and School and the

manufacturers who ought to be interested in them.

For the past fifteen years Mr. Winslow has been prominently connected with the development of industrial education. In 1906 he was a member of the Massachusetts Commission on Industrial Education; in 1910 he was engaged by the U. S. Bureau of Labor Statistics in getting out the twenty-fifth annual report which dealt with industrial education; in 1912 and 1913 he was the special agent of the U. S. Government on the conciliation and arbitration commission that sought to settle labor troubles in New York City; in 1914 he was appointed by President Wilson as a member of the Commission on Federal Aid for Voca-



CHARLES H. WINSLOW

tional Education. During the next four years he was busy with survey and organization work in several cities and in 1917 he was engaged by the Federal Board for Vocational Education as assistant director of research.

E. E. ERICSON JOINS THE STAFF OF THIS MAGAZINE

BEGINNING on the first of August, E. E. Ericson becomes a member of the office staff of *The Manual Arts Press*. He has been induced to give up

his position as supervisor of manual arts in the public schools of Okmulgee, Oklahoma, and will devote his entire effort to writing and editorial work on the *Manual Training Magazine* and books published by *The Manual Arts Press*.



E. E. ERICSON

Mr. Ericson received his B. S. degree at Stout Institute in 1915. He has had experience as a teacher in public schools, and in a normal school, and for two years he has been a city supervisor under a progressive administration. Previous to this teaching experience Mr. Ericson had four years of practical experience in general woodwork, mill work and wood finishing, one year in carpentry and a summer in drafting. During the present summer he is teaching the courses in industrial education at the University of West Virginia. The character of the writings of Mr. Ericson is already known to our readers both thru his news items from the Southwest and his longer articles.

A NEW CORRESPONDENT IN THE EAST

IN AN effort to cover the Eastern field more thoroly the editors have asked Allen D. Backus, supervisor of manual

training and of industrial and vocational evening classes at Newark, N. J., to represent this Magazine in collecting news items of interest in the states of New Jersey, Delaware and Pennsylvania. We hope that all our readers in those states will assist by sending him facts of general interest concerning the progress of their work and reports of meetings.



UEL W. LAMKIN

Mr. Backus received his professional training at Pratt Institute and Teachers College, Columbia University. He spent a year in architectural work in Colorado and California. His first teaching was done in Salt Lake City public schools, 1910-12. Then he taught manual training for a year in Scottdale, Pa., two years at Oneonta, N. Y. In 1915 he went to Newark as instructor in manual training. In 1919 he was promoted to the supervisorship. He is one of the champions of the Intensive Plan of organizing arts work, which, if generally adopted, will rid manual training instruction of several serious handicaps.

MR. LAMPKIN RESIGNS

UEL W. LAMKIN has left his position as director of the Federal Board for Vocational Education in order to accept the presidency of the state normal school at Maryville, Missouri. His resignation took effect at the end of June and he went directly to Maryville in order to be there during the summer school.

In making this change, Mr. Lamkin returns to his native state where he has held various educational positions, including that of state superintendent of public instruction.

Mr. Lamkin deserves special commendation for the effective answers he made last year to the undeserved criticism of the rehabilitation work of the Federal Board for Vocational Education which was then under his immediate supervision.

THE HOUSEHOLD MECHANICS COURSE

PORTLAND, Oregon, is developing work in household mechanics. In discussing the character of the manual training course recently, F. M. Groshong, supervisor in Portland said:—

The activities of the shop must be more closely connected with the home life of the boy. The problems of a modern American home are rapidly increasing. New labor saving devices are added almost daily. The so-called household mechanics course, which is becoming a vital part of our manual training work, has inaugurated a sort of know-your-own-home-first campaign among the boys.

It is our problem to familiarize the boy with materials and methods of construction used in building a modern house. He must study the various household appliances, their use and operation. He must understand their value and learn to assist in their care and maintenance. The electric lighting and bell ringing systems, motor driven machinery, and plumbing fixtures and equipment all offer interesting fields for practical work and study.

With us, the qualification of voters is as important as the qualification of governors, and even comes first in the national order.

—HORACE MANN.

A POINT OF VIEW

PETER BEOWULF

THIS is August—a time of dog days and the presence of that old warrior General Humidity and his adjutant Hay Fever; a time of counting the days when the summer session will be over and the fall term commencing; a period of recreating and vacationing; an interval for light editorials. It is a resting place for the healing of work wounds, for gathering fresh blood for work days to come, and perhaps one of reflection and stocktaking.

I have been recreating, vacationing, reflecting and stocktaking, i. e. I have hopes that I am a bit recreated, I know that I vacated, (I take it that a vacation means "to vacate"), I ought to have reflected. But I decline to exhibit my balance sheet.

I went away with Peter Beowulf—a combination name of a saint and a warrior. While such combined qualities are desirable, I confess that the coupling of them in one personage is open to doubt. However that may be, Peter and I started out to see schools, to sleep out of doors, and to discover whether we could really establish everlasting companionship.

You know the good and bad qualities of people always show up in a camp. Their ability to co-operate, their willingness to do their share of unskilled labor, their watchfulness to get from under the feet of those who are cooking, their interest in nature and camp environments, their acquiescence in eating what is set before them, their appreciation of the dainty especially provided for their comfort when the supply depot is miles away and finally their watchfulness for maintaining a camp morale—all prove or disprove camp palship.

Peter showed that he had these qual-

ities to a marked degree. He was a moral force in our little community life. The everchanging camp was his pride. The means of transportation—an automobile of the harvest season of 1915—was to him as fine as any Rolls Royce. Yes! We have established a perfect understanding.

I do not think that he holds the same point of view towards vocational education which I hold. He certainly has no patience with those who would argue for hours over debatable issues in this field of education. I rather suspect that he looks with suspicion on some of my work. In fact he forced me to develop some new notes thru inadvertently destroying some I had. (It was time that I had new ones and his judgment was correct).

In general he thinks a lot of my judgment and that always flatters anyone. Imitation is the sincerest of flattery and Peter is a most subtle flatterer. He seldom talks and that is a good quality in a road companion to a man who likes to reflect. He never answers me back except to agree with my decision, which satisfies my ego. He listens for hours and his understanding and his agreement are most sympathetic to one who spends so much time in an academic atmosphere of discussion which never has a terminal. He never questioned any camping spot, raised no objection to the hour of arrival or departure, entered no complaint because condensed milk was the substitute for fresh milk, started the day good naturedly and closed it with cheerfulness. He brought choice sticks for the fire, found the thirst quenching spring, pulled on the tent ropes and cleaned up all the left overs. As morale officer, he was perfection itself. No one could intrude

without giving the countersign and answering the question "Are you a friend to my friend?"

Of course Peter has weaknesses. If he was not so confoundedly non-committal, he might disclose mine. He is not up to Mr. Edison's standards as exemplified by the tests which have been so widely discussed. He thinks they were far too much taken up with technical questions, ability to answer which would indicate chiefly either some specializing in study or a memory of a card catalogue order. Peter's apparent reaction is that the test contained too few questions calculated to grade general intelligence, power of observation and the reasoning faculties.

Neither does Peter like to visit vocational schools. In this, I fear, trouble brews. I trust it will not cause a separation. But it is disquieting to your hobby to have your best friend, when you get to a school, say, "You go on in, I'd much rather sit here in the car and do my regular morale work."

Again, Peter is not always polite. The other day I had a caller who in Peter's estimation outstaid his welcome with the result that the soul of punctuality brought me my hat. The visitor took the hint as he said "Evidently he thinks I should go." But with a Chesterfieldian reply I said, "You notice that he brought me *my* hat and not yours." Thereupon, Peter grinned and brought the visitor's hat.

Of course Peter has had a good deal of organic education of the type which Mrs. Johnson of Fairhope, Alabama, would approve. He has a strong sense of direction, wonderful eyesight and hearing. His body is under perfect control. He can swim and jump, seal walk, and play games.

Do not understand that he is an old personage. In fact, he is young. He

is now only of Junior High School age. He has just left the elementary school where he learned, I fear, only to use his body in ways that God intended, to obey implicitly, to choose friends wisely, and to use his senses, mixed with that uncommon thing—common sense (why we call it common is more than I know, as it is a most unusual article.) In other words he has had a sort of John Dewey type of elementary schooling.

The time had arrived for him to take an exploring and expose course. Hence this trip. He was to see how others lived, to see them in their home, to watch them work and play, to see the industrial life of noisy streets and the sobering still life of the country road. He was to have his obedience tested under temptation. He was to see whether his organic education gave him a sturdiness of body and spirit. He was to hear the clatter of looms, the shriek of the locomotive, the purring of motors, and the clanging of fire trucks. He was to observe the old well sweep, the shoe shop, the blacksmith forge, the stone mills, the colonial porches, the covered frame bridges—all of old New England—that he might know the differences between the old expressions of industry and the new. His teacher, following the method of Professor Bonser, gave him a course in industrial arts treated from the historical angle of development of the purpose of giving him a more vocational conception of his life choice of a job.

As his guardian and protector (?) I am much concerned whether these experiences should all be grouped in one room with one teacher and developed on a project basis or whether Peter should devote 5 weeks to each activity in separate shops under trade teachers. I am not able to decide whether he should be compelled to take each and all of these "experiences" or allowed to select one

that he likes and stick by that. Furthermore, I am puzzled how to bring to the classroom all the experiences he should have, in view of the fact that there are over 300 different occupations and my equipment only provides for five types of work. (As yet, Peter has not read Dr. Snedden's chapter on "Amateur Work for Junior High Schools.")

Again, I am much concerned over the question whether what Peter picks up outside of "schooling" constitutes an education and whether I can and should give school credit for the same. (He hears a lot about credits and theses on the campus). I am tremendously concerned over the question whether these adolescent interests are permanent or not and how much importance I should attach to them. I realize that to him they are very real. During the trip Peter was very much interested in nature study, especially quadrupeds. He may develop into a naturalist. In the city he explores small shops. He may want to be a store keeper. He has a fondness for policemen and always expects recognition. Perhaps he is to be a Sherlock Holmes. He shows no interest in machinery beyond egg beaters, automobiles and motor boats, and in these he shows a receptive attitude towards what they can do for him rather than what he can do for or with them. This point has confused me most of all, i. e., is Peter's special interest in some things due to the pleasure they give him or to the genuine intellectual contribution which he makes to them? In other words, is he really learning about automobiles or is he merely enjoying them? How much of the play spirit is essential in developing his work spirit? At present, when we go walking, he wants to step into every car he sees. Supposing I tell him that as an automobile engineer, he will be more concerned with mathematics, diagrams of explosions, cam

movements and gear teeth than with road driving, will he still have his present interest in interstate touring?

I have never sent Peter to the public school, "not because I do not believe in them" but because "he could develop faster under private instruction." At the public school he would have been compelled to sit in a cell-like seat at a period when I knew that his body required freedom for expression. I knew that his growing nervous system needed expression rather than repression. I felt that his personality would develop more freely and hence more distinctly if he had a motive for doing things other than obtaining a good school record. Furthermore, I wanted him to obey, to be full of response, to have quick action. In short, to keep his mind and body active at all times, and not to wait until "his turn came to recite" before coming out of his youthful day dreams.

"What will he be when he grows up?" Fortunately or unfortunately his career is marked out for him. He has ancestral names in the Blue Book. On his father's side they were daily visitors to the court of Emperor William. On his mother's, they were often seen in company with the King of Spain. His grandfather was educated in Paris, and as for himself, he has lived on a University Campus and associated with leaders in the intellectual world. He probably has his suspicions of the value of all that he sees and hears.

I regret that his gentle breeding does not yet recognize that persons wearing old clothes or carrying bundles are often and usually people of a quality as good as his daily associates. I am telling him that in these days of high living costs and the customary low salaries of the college professors, that he must not think that old clothes wearing and bundle carrying are signs of impoverished souls and reputations. He must learn to distinguish

people by other means than the feathers they wear.

His vocational life does not worry me. He had excellent parents, has enjoyed plenty of experience and has inherent tendencies which will force him into a field which God intended him to take. Peter is a product of fatalism. He knows he cannot be President. Between heritage and environment his work is cut out for him. I see no opportunity for giving him vocational guidance or direction.

Consciously or unconsciously, in the upbringing of Peter, I have been following the method of the Moraine Park School. I am attempting to have him master the arts of life. They are mastered by doing and not by looking on. These "arts of life" are ten in number. They are set down in this school as "occupations:" (1) Body-building (2) Spirit-building (3) Society-serving (4) Man-conserving (5) Opinion forming (6) Truth discerning (7) Thoughts-expressing (8) Wealth-producing (9) Comrade or mate seeking (10) Life-refreshing.

Peter has no "marks," for example in history. If he studied the subject it would be listed under No. 5. Dates count less than fairness of mind and judgment which are bi-products of history teaching. If Peter studied chemistry or botany, he would have the result of his study listed under Truth-discovering. "Body-building" includes eating carefully and regular exercise. "Spirit-building" is made up of loyalty to high ideals, efforts to do the best and trustworthiness. Under "Society serving" come obedience, respect for law and faithfulness in office. "Man-conserving" concerns itself with spirit of helpfulness and home-making.

Contributing to "comrade or mate seeking" ability are the elements of co-operation, agreeableness and frankness. The mastery of the art of "life refreshing" are play interest, sportsmanlike spirit and resourcefulness.

I regret that Peter is not as broad and catholic as Morgan of Dayton expects the children of his school to be. Peter is not yet a thoro good sportsman. Only this morning he sought a quarrel with a much younger and smaller personage than himself. He is narrow in his conception of comrade seeking in that he sticks by my side irrespective of all the good people around us—altho I must say that he is agreeable and frank toward others. Under the head of "Society serving" he places great responsibility on me in that his conception of this function is based entirely upon my conception of it. He has an I-go-where-you-go-and-do-as-you-do attitude. My law is evidently his law and that makes it important that I know good law. His capacity for "spirit-building" can be rated high because he always tries to do the best and be worthy of trust. When it comes to body-building he has a mark of A+.

Every teacher should have a Peter. Thru my Peter—and those who have loved a dog know that he is as real as a human Peter—I have learned something of the value of laws of habit, of the exercise of patience and of the rules of apperception. I have experienced that great love and understanding which one pal may give to another. I have felt the reverence that the younger and more immature may give to the older and more experienced. To Peter I am God. His faith is great. May mine be as strong!

—ARTHUR DEAN.

WASHINGTON CORRESPONDENCE

BUDGET BUREAU ORGANIZES

THE one event of the past month which has attracted the most attention, and which makes the greatest appeal to the imagination, was the meeting called by President Harding at which he introduced General Dawes as chief of the new Budget Bureau. This is not strictly speaking an educational matter, and yet it is of sufficient importance to us all to justify my telling the story briefly here.

As every well-informed citizen knows, Congress has passed and the President has signed a measure which provides for the beginnings of budget procedure in administering government expenditures. Upon the passing of the Act President Harding promptly appointed Brig. Gen. Charles G. Dawes as director. Mr. Dawes has seen service as Comptroller of the Currency, as a successful banker and lawyer, and more recently with our armies in France. His selection as director of the budget bureau has probably done more than any other one thing to convince the public that substantial changes in government spending are contemplated.

A MEETING OF HISTORIC SIGNIFICANCE

WITH characteristic energy Director Dawes immediately set to work on plans for the organization of the new bureau, with the intention of having it ready to begin operations on a full head of steam on the opening day, July 1. One of the most significant steps in the development of the plans was the holding of a meeting of all chiefs and assistant chiefs and chief clerks of all government establishments, which occurred on Wednesday afternoon, June 29th. For the first time in the history of the government a general meeting was called of those officials in all departments who actually spend the

money, for the purpose of devising ways and means for reducing expenditures.

Whether rightly or wrongly, there has grown up the popular belief that the various government bureaus in making estimates of the appropriations needed frequently ask for more than is actually needed, and more than they expect to receive, on the theory that Congress will cut the estimates anyhow in order to show economies. The responsibility for the preparation of these estimates, and the responsibility for expending the funds appropriated, rests for the most part on chiefs of bureaus and other subordinates, since the Cabinet officers and other heads cannot be expected to master details. As one editorial writer expressed it the other day:

No cabinet officer can possibly have an accurate knowledge of the quantity of stationery and supplies required for his department, how many tons of coal are consumed, how many employees are necessary to the efficient conduct of each bureau under his jurisdiction, and a thousand and one other details which enter into the expense account of his department.

Inaugurating what another writer called "a new era of governmental administration on a business and efficiency foundation," Gen. Dawes therefore strikes at a vital point in the whole system by calling these officials in conference and thus holding an "unprecedented business meeting" of the administrative branch of the government.

A CALL TO PUBLIC SERVICE

IN calling the meeting to order, President Harding, who presided, called attention to "growing public indebtedness and mounting public expenditures" as one of the greatest menaces in the world today. Referring to the mistaken notions that the "public treasuries are seemingly inexhaustible," and that efficiency and economy in the public busi-

ness are unnecessary, he said, "We want to reverse things."

The President appealed to the assembled officials, as the ones "directly responsible for a better order of affairs in this drive for efficiency and economy, if it is to be brought about," to look upon this as a most significant opportunity for public service.

In his address following the President, General Dawes said he was willing to set an example of what he proposed to preach, and announced his intention to cut the appropriation for his own bureau 25 per cent. Incidentally this will mean a substantial reduction in what every student of the situation has recognized as an inadequate appropriation for the enormous task set before the bureau.

With the approval of the President, it is proposed to analyze the estimates and the appropriations for the fiscal year just beginning, instead of waiting to consider the estimates which would normally be presented to Congress next December

covering the year beginning July 1, 1922. General Dawes has announced his purpose to draft a budget of expenditures for this year which shall fix as its maximum total a sum substantially less than the appropriations already made by Congress. This is itself a radical change from the point of view which has always prevailed heretofore, and which has regarded the appropriations as the minimum amount to be spent.

The 500 or more officials present were urged to join hands with the director of the budget in the task of bringing this to pass, with the determination to make it effective. In concluding his address, General Dawes turned to the President, and said:

These men, of whom I am one, realize the perplexity of your position—realize that the business of the country is prostrate, that its workingmen are out of employment, that we are faced with inexorable necessity of reducing expenditures; and we propose, just as we did four years ago to win the war, to try to do it.

—WILLIAM T. BAWDEN.

IN FOREIGN COUNTRIES

DOUBTS THE PRACTICABILITY OF LEARNING TRADES IN MODERN COMMERCIAL SHOPS

THE London *Times Engineering Supplement* of April prints the following as part of a two-column article on "National Instructional Factories." Readers will recall that what are termed "instructional factories" have been established by the British Government in order to carry forward effectively the work of rehabilitating ex-service men of the Great War. An extensive exhibition of these Government "factories" held recently at Ipswich attracted much public attention. The success of this means of training for industry has been demonstrated. The writer of the *Times* article sees in these factories what seems

to him to be the best solution of the problem of trade teaching.

Those interested in industrial training and apprenticeship will have noted, from discussion of the subject in this country, America, and New South Wales, that the view is beginning to gain ground that it is doubtful whether after all the employer's workshop is the best place in which a lad can learn his trade. It is being pointed out that the modifications in the conditions of industry during the last few years have been such that the bulk of workshops to-day can offer only a sort of half-training in practically any trade where not so many years ago they could have given an all-round training.

Further, there is said to be less keenness on the part of both operatives and employers to train boys. This may be due on the part of the employer to the relatively high wages which are now demanded for apprentices, and on the part of the operative to the desire, especially in present economic circumstances, to discourage learners as far as possible. Undoubtedly also employers refuse to take appren-

tices because they know they have not the facilities to train them as thoroly as they would wish, and also because boys between 14 and 16 are not an easy problem, and there is no certainty that a contract entered into with them will be kept. Manifestly this state of things is not satisfactory, and it is worth while to examine some alternative methods of dealing with the training problem, which have lately been put forward both in this country and in others.

WHAT SHOULD BE TAUGHT

Until recently, with the exception of a few highly organized trades, very little information was available as to what a boy should be taught during his apprenticeship, in order to graduate as a fully skilled man. If, for instance, he wanted to become a printer or a boot-maker, or a baker, his father or guardian made some arrangements with a local employer to take him on; an indenture, always vague and meaningless, with no reference whatever as to the processes the boy was to be taught, was drawn up, and the boy afterwards was turned loose in the shops to pick up what he could. In the circumstances all the credit was his if at the end of five, six, or seven years he could call himself a skilled man.

Of late, however, all countries that took part in the war have had to interest themselves seriously in the great problem of re-settlement of maimed and disabled men, and in problems of industrial training, and the experience gained will certainly be valuable for all time. Almost every skilled trade has been analyzed, with the object of discovering what are the processes to be known in each before the man can rank as a skilled man, what are the best methods of teaching these processes, and under what condition are they most easily assimilated. In practically every country centres under Government control, financed out of public funds, have been set up, and in these a hundred processes and trades have been taught to disabled men, who have been enabled to return to industry in extraordinarily short periods of time to take their place beside skilled workers. The methods employed have been the result of careful discussion and experiment, and the general result is that for the bulk of modern processes the best way to teach them has probably been discovered. Employers, on the other hand, also have not been a little surprised at the results which have followed a scientific thoro organization of the methods of training. Many of them have said that the methods of the Government instruction centres have in a measure set up standards for the industry and have further declared that it would be much more valuable to industry if boys, instead of

entering the employer's workshop direct from school, could spend their first two years in a factory organized on similar lines to that of the Government instructional factory.

The writer of the article would retain these "instructional factories" after they have been vacated by the ex-soldiers, and use them as trade schools, the expense of maintenance to be divided in some way between the State and the industries.

SLOYD SCHOOL IN ASKOV, DENMARK

SLOYD is the term used for manual training in the Scandinavian countries. The school in Askov was established in 1895. Anders Nielsen, who spent some time in the United States studying our methods in the manual arts, is principal and proprietor. The course of study is designed for boys in the adolescent period. The session runs from Nov. 3 to April 1. An average of 50 boys are in yearly attendance. They live as one big family while pursuing their studies. The tuition is 85 Kroner per month. The charge includes: board, lodging, instruction and materials used in constructing models which the pupils can take home with them.

The course of instruction is as follows:

SUBJECT	HOURS PER WEEK
Sloyd.....	24
Gymnastics.....	5
Danish.....	7
Mathematics.....	6
English.....	3
Writing.....	2
Drawing.....	5
Social Studies.....	5

Sundays are occupied by hikes, lectures and devotional exercises. This makes a balanced life for the pupils. The work is very efficiently supervised; only correct projects are approved. The school is typical of a great number of similar enterprises thruout Denmark.

—MARIUS HANSOME.



PROJECTS, PROBLEMS AND NOTES

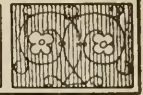

CRATE CORNERS

THE corner is the weakest part of the ordinary crate. Some facts about crate corners observed in tests at the Forest Products Laboratory, Madison, Wis., may be of assistance to teachers as well as to crate builders in strengthening this weak part by better arrangement of members and methods of nailing or bolting.

Seldom if ever does the 3-way corner construction increase the volume of the crate. On the contrary it usually reduces the space occupied. When properly nailed or bolted, this type of corner has a considerable bracing effect, altho it does not do away with the need for diagonal bracing.

The sixteen possible arrangements of members at a 3-way corner are given in Fig. 7. It will be

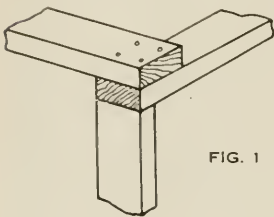

FIG. 1

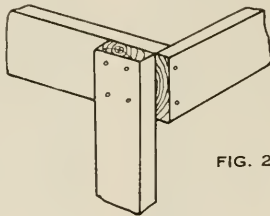

FIG. 2

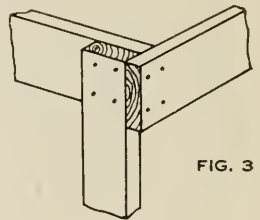

FIG. 3

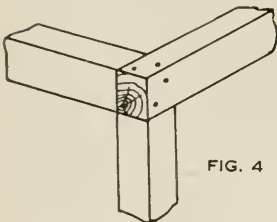

FIG. 4

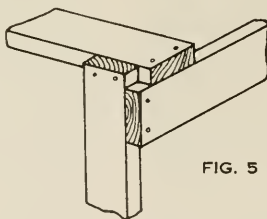

FIG. 5

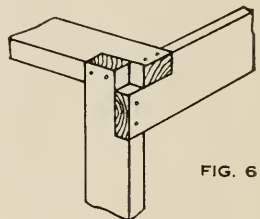

FIG. 6

An example of inexpert crating frequently met with is that shown in Fig. 1. This construction is poor because the nails holding one member are driven into end grain and so have comparatively low holding power. Another common example of the same fault is shown in Fig. 2. This construction may be improved, Fig. 3, by lengthening the member to permit nailing into the side grain.

The corner construction shown in Fig. 4 is very weak, because the only nailing possible is thru one member into the end grain of the other two. This style of corner is frequently used in crates which are to be entirely covered with sheathing. In a crate without sheathing it would, of course, be worthless.

In Fig. 5 each member is nailed to another member and has the third member nailed to it. This is a very effective arrangement. It is called the 3-way corner, and the distinguishing feature is that each member is held by nails or bolts in two directions. Fig. 6 is suggestive of further variations of the 3-way principle, with the members notched together.

seen that A and I are the most practical when the object to be crated is a box-like form, such as a filing case. When the object is of irregular form, such as an electric motor, one of the other arrangements may have the advantage of permitting better bracing and blocking.

Proper arrangement of members will not in itself produce a good corner. They must be properly fastened together. Whether bolts or nails should be used depends principally on (1) the thickness of the members, (2) the amount of stiffening afforded by sheathing, and (3) labor costs.

Examination of the corner shown in Fig. 8 shows that the three pieces of which it is constructed are assembled in such a manner that they take up the least amount of shipping space, and that each piece holds the points of two nails in the side grain of the wood. Furthermore, each piece is nailed in two separate places, there being four nails driven into each, and the arrangement of these nails is such that it is impossible to break the crate open without breaking the wood to pieces or drawing the nails out with a nail puller. In this respect the

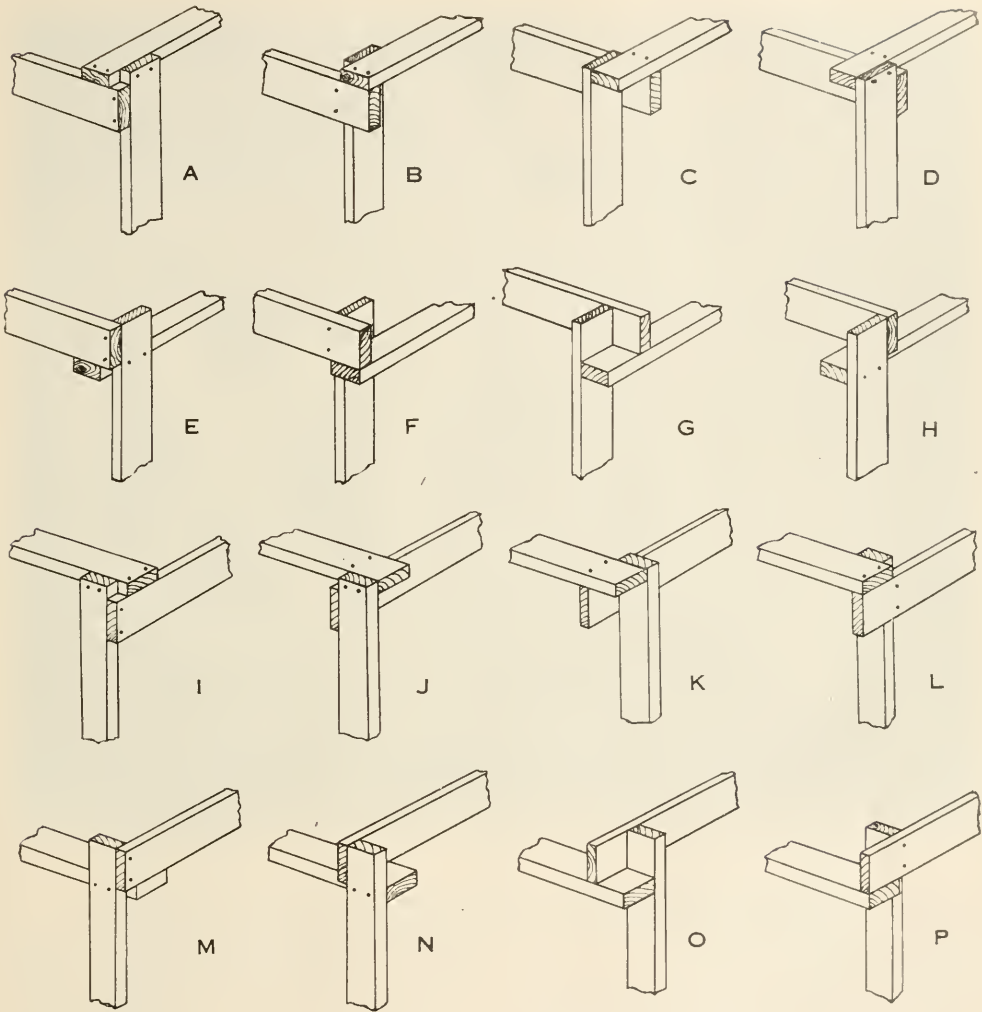

FIG. 7—ARRANGEMENT OF MEMBERS AT 3-WAY CORNER

3-way corner is different from the ordinary box construction in which the boards can be pounded apart without injury to them.

Nails driven in holes slightly ($\frac{1}{32}$ to $\frac{1}{16}$ inch) smaller than their diameter have considerably more resistance both to direct pull and to shear than nails driven without holes. Cement coated nails are superior to uncoated nails. Length of nails should be somewhat more than twice the thickness of the member holding the heads.

Slender nails are likely to hold better than thick nails under the repeated shocks and constant weaving action to which crates are subjected, because the slender nails bend near the surface of the pieces joined without loosening the friction grip towards the point.

The number of nails or bolts joining one member to any other member should not be less than two. Usually as many nails as can be driven without splitting should be used.

Danger of splitting will be reduced if nails are staggered. Boring holes for nails also reduces the danger of splitting.

Bolts have the advantage of holding after the friction grip of the wood on the shank is destroyed. The following schedule of bolt sizes is suggested as a guide:

THICKNESS OF CRATE MEMBERS	DIAMETER OF BOLTS
Up to $1\frac{1}{2}$ inches	$\frac{3}{8}$ inches
$1\frac{1}{2}$ to 3 inches	$\frac{1}{2}$ inches
3 to 5 inches	$\frac{5}{8}$ inches

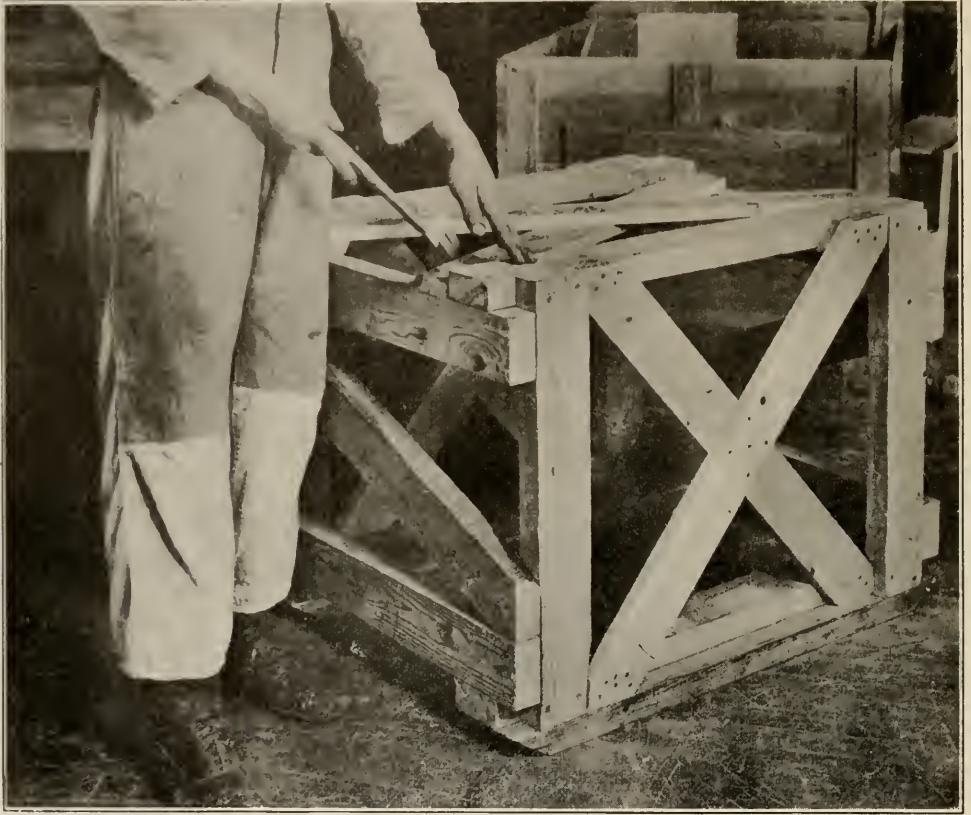

FIG. 8—CRATE SHOWING 3-WAY CORNER CONSTRUCTION

Machine bolts should have washers, and the heads should be countersunk.

Carriage bolts are preferred to machine bolts and may be used without washers under their heads.

Nuts should if possible be on the inner side.

Locknuts should be used on all bolts; or, if there is no expectation of using the crate a second time, the threads may be deformed to prevent loosening of nuts.

Holes for bolts should be bored to the same diameter as the bolts—or $\frac{1}{32}$ inch smaller.

—FOREST PRODUCTS LABORATORY.

BOOKCASE

ALTHO the sectional bookcase has come into general use, there is still a steady demand for good period pieces. The accompanying drawing shows a design which works out well, and is quite popular with pupils of discriminating tastes.

This is a typical William and Mary design, which works out well in either mahogany or black walnut.

The legs are made of one single piece, extra mate-

rial being glued on for the "bell" at the bottom. It can be turned without difficulty if centered carefully. The legs are doweled to the ends.

The ends are made of $\frac{3}{4}$ " stock. The top and shelves are also $\frac{3}{4}$ " stock, which takes care of all lateral expansion. The shelves can be fastened by nailing, or can be made adjustable. Of course the bookcase will be stronger if the shelves are fastened in permanently, and the back bradded solidly to them.

The back can be made of beaver board, or composition board, or of $\frac{3}{8}$ " beaded ceiling boards. The author recommends the latter.

The details illustrate the leg construction at the bottom of the doors, brace design and construction, and suggest a design for the inside of the glass at the top of each door.

While intended primarily as a bookcase, this design will work equally well as a china cabinet, if each end is built with a glazed panel.

—E. C. POWELL,
Massillon, Ohio.

BOOK-CASE.

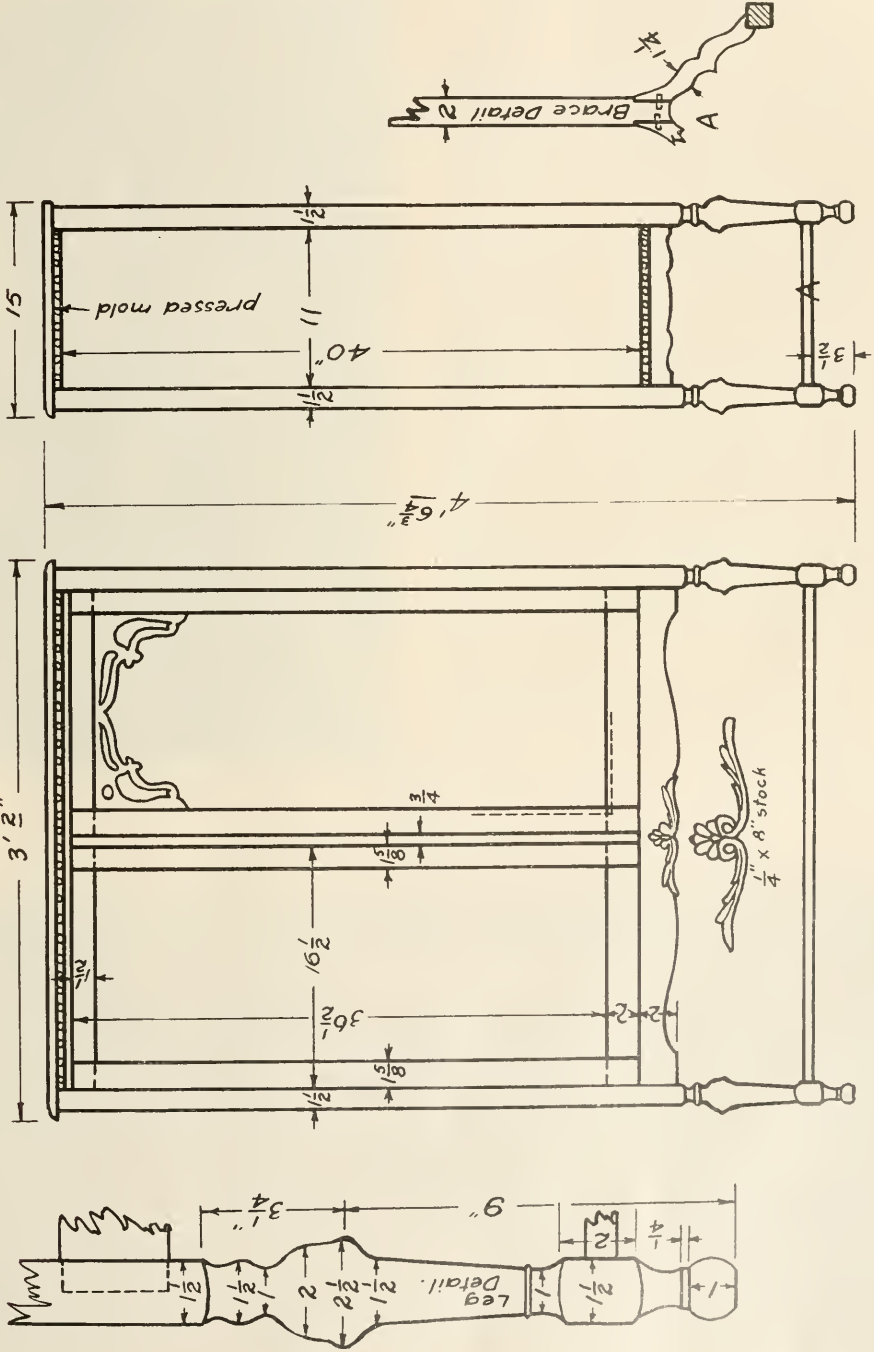

MITER-BOX TABLE

Mr. Editor:

I am enclosing a drawing and photograph of a miter-box table which we have found very convenient, and which has added materially to the efficiency of our shop.

The object of the table is to give, easily and quickly, accurate measurements for cutting. The movable "stop" is adjusted by turning two thumb screws. Also, if it is desired to cut long pieces, by moving the stop to the back slot it will serve as a guide to keep the long pieces straight and parallel to the fence of the miter-box.

The rule may be made either by using two yard sticks or by making a continuous one out of hardwood. The top of the table is grooved to receive the same. A box, placed on the floor beneath the table, will catch all cuttings, as the supports of the box have a wide space between them.

—J. DOUGLAS WILSON,
Riverside, California.



VIEW OF MITER-BOX TABLE

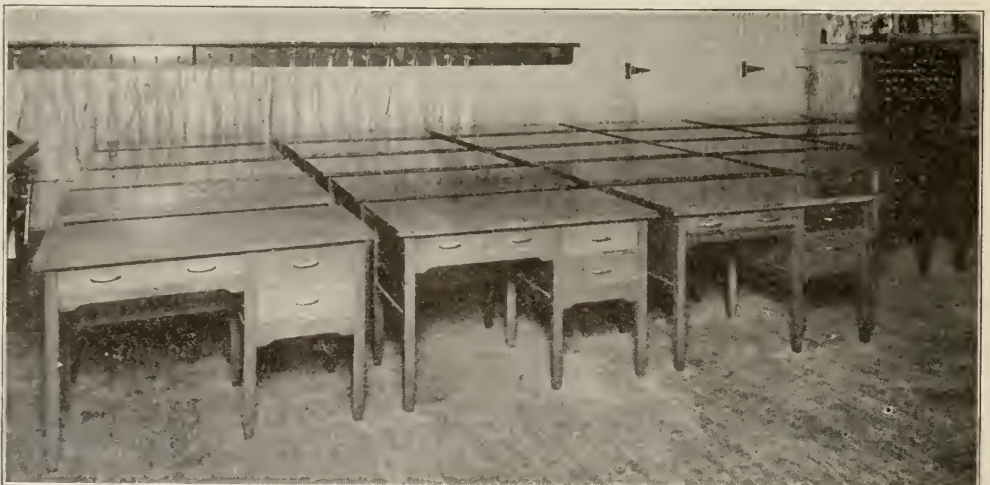

ABOUT 400 SUCH DESKS HAVE BEEN MADE IN SCHOOL FACTORY OF DES MOINES. THESE WERE MADE LAST YEAR WHEN OAK WAS USED; THIS YEAR SUCH DESKS ARE BEING MADE OF BLACK WALNUT. SEE PAGE 50.

MITER BOX TABLE

Drawn by Albert Haight
Polytechnic High School
Riveride, Calif

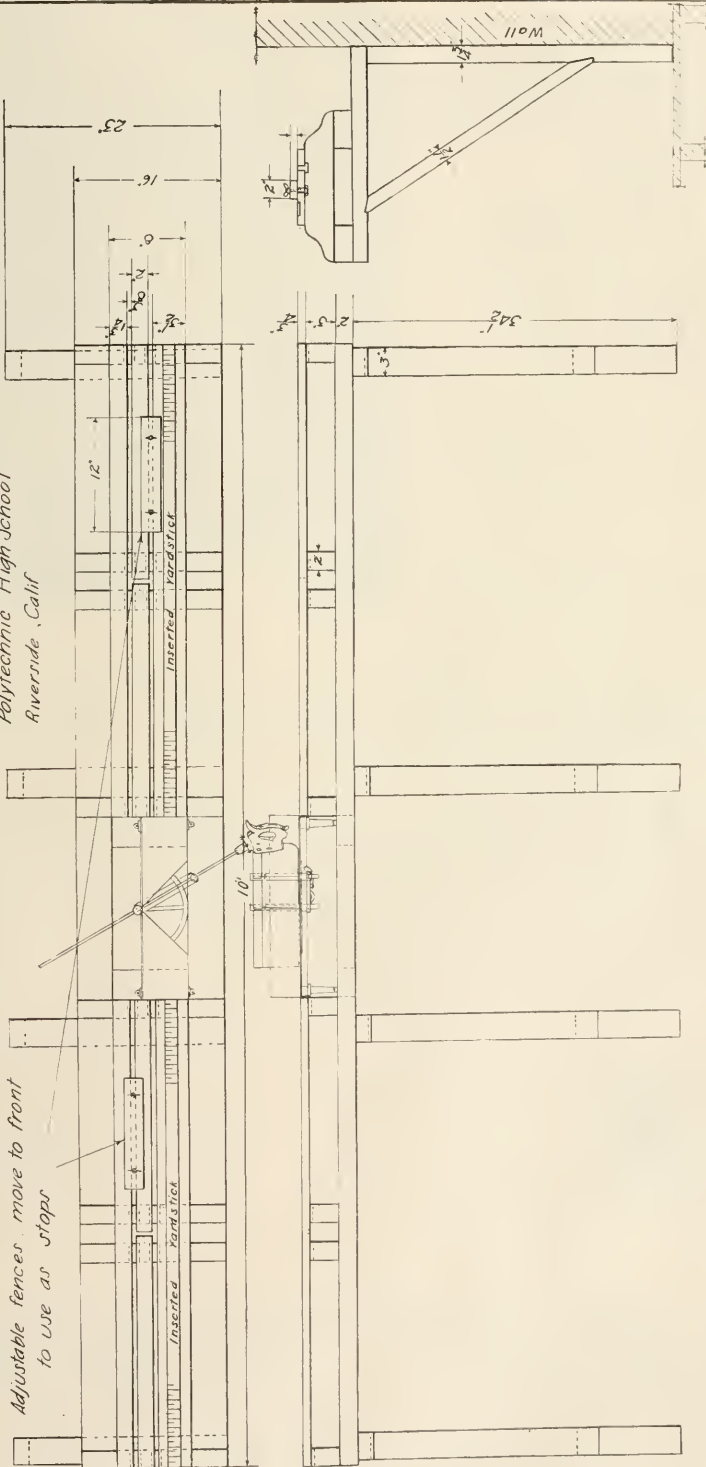

Adjustable fences, move to front
to use as stops

CURRENT PUBLICATIONS

RECEIVED

American Apprenticeship and Industrial Education. By Paul H. Douglas, Assistant Professor of Labor Administration, The University of Chicago. Studies in History, Economics, and Public Law, Volume XCV, Number 2. Published by Columbia University; Longmans, Green & Co., Agents. Size 6 x 9 in.; 348 pages.

Among the 17 concluding recommendations of the author are: (1) the raising of the age of compulsory full-time education from 14 to 16 years, (2) the provision of scholarships to compensate parents of poor children for loss of earning power, (3) the revision of the school curriculum for the two added years so as to include both general and prevocational subjects, the latter preferably in the form of manual training, (4) the establishment of compulsory continuation schools for children between 16 and 18, (5) the prohibition of entrance into certain "blind-alley" trades, such as those of newsboy, bootblack, chambermaid, for children under 18, and (6) the creation of a Federal Department of Education. The book is an important contribution to the discussion of industrial education problems. It shows the advantages and disadvantages of the former apprenticeship system, and of its modern substitutes, such as manual training, and trade, industrial, evening, correspondence, and continuation schools.

A History of Industry. By Ellen L. Osgood, Haaren High School, New York, N. Y. Published by Ginn & Co., Boston, 1921. Size, 5½ x 8 in.; 426 pages; illustrated; price, \$1.72.

This book describes the rise of industry from the crude efforts of savages to the modern factory. It possesses the romantic interest of a well-written history of wide scope, and also furnishes an historical background for the study of economics. Especial attention is given to the industrial history of the United States, to which several chapters are devoted. The book is the fruit of several years' experience in teaching industrial history in the high school. As a text it should furnish a valuable nucleus for reading in a subject which is becoming more and more important in the modern high school curriculum.

Rope Work. By Louis M. Roehl, Supervisor of Farm Shop Work, Cornell University. Published by The Bruce Publishing Co., Milwaukee, Wis. Size, 6 x 9½ in.; 47 pages; illustrated; price 80 cents.

This book is designed to teach the farm boy the more useful knots, hitches, and splices. The author is convinced that skill in a few knots is more desirable than a faint knowledge of many. To this end each important knot is analyzed, and its several processes illustrated. There is also a description of grades of ropes, with a table of their sizes, weights, and strength.

Vocational Education in the States. Issued, Feb. 1920, by the National Society for Vocational Education, 143 West 42nd St., New York.

Western Arts Association Bulletin, June 15, 1921. Announcements and Membership list. Published by the Association, L. R. Abbott, Secretary, 234 Division Ave., N., Grand Rapids, Mich.

Proceedings of the First National Conference on Technical Education, Ottawa, October 25-26, 1920. Issued by the Director of Technical Education, Department of Labour, Canada.

First Annual Report of the Director of Technical Education for Canada for the fiscal year ending Mar. 31, 1920. Issued by the Department of Labour, Ottawa.

Circular for Teachers and Students, printed by order of the Legislative Assembly, 1921-22. Literature selections in English and foreign languages, text and reference books for public, high and normal schools, amendments to regulations and courses of study. Issued by the Government of the Province of Saskatchewan, Department of Education.

Report of Division of Educational Tests for 1920. By Walter S. Monroe. University of Illinois Bulletin, Jan. 24, 1921. Price 25 cents.

The Francis Scott Key School, Locust Point, Baltimore. Report of a study of the school and local industries with reference to the enrichment of the school curriculum and the planning of a new school building. By Charles A. Bennett. Bulletin, 1920, No. 41, U. S. Bureau of Education, Washington, D. C.

Flytraps and Their Operation. By F. C. Bishopp. Farmers' Bulletin 734, U. S. Department of Agriculture.

Vocational Training. Opportunities in the Los Angeles City High Schools. Los Angeles City School District, School Publication No. 36, May 1921.

The Story of the Pilgrims. By Boston Prevocational Classes. Edited by the Agassiz Prevocational Printing Class, Jamaica Plain, Mass.

History of the Greenfield Tap and Die Corporation, Greenfield, Mass. Issued on the occasion of the formal opening of the Administration Building, Mar. 5, 1918.

Chart Showing Important Dates in the History of Furniture. Souvenir of the Furniture Exhibition, Feb. 1921. Issued by the Pennsylvania Museum and School of Industrial Art, Broad and Pine Sts., Philadelphia.

Schooling for Vocations. A circular of information issued by the Vocational School, Atlantic City, N. J.



Tapping for new bolt in exhaust pipe bracket

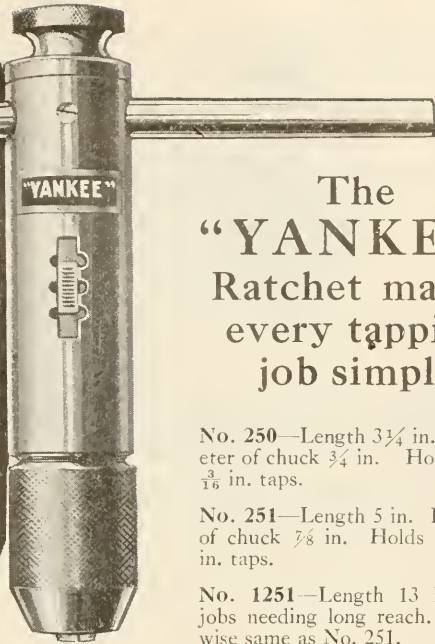

The "YANKEE" Ratchet makes every tapping job simple

No. 250—Length $3\frac{3}{4}$ in. Diameter of chuck $\frac{3}{4}$ in. Holds up to $\frac{3}{16}$ in. taps.

No. 251—Length 5 in. Diameter of chuck $\frac{7}{8}$ in. Holds up to $\frac{5}{16}$ in. taps.

No. 1251—Length 13 in. For jobs needing long reach. Otherwise same as No. 251.

"YANKEE" Ratchet Tap Wrench

"It will take hours," says the mechanic who has no "Yankee" Tap Wrench. "I'll have it done in a jiffy," says the man who has one. That's the story on every difficult tapping job.

Here's why: You don't have to take the work apart to get at the hole when you use a "Yankee" Ratchet Tap Wrench. An inch or two to work in is enough. Slightest movement of cross bar keeps tap cutting.

A finger-touch gives you Left or Right-hand Ratchet movement—or rigid adjustment. Cross bar slides easily to either end or center and **STAYS PUT**. Knurled thumb-piece is mighty handy for quickly starting taps or backing out.

Free "Yankee" Tool Book pictures and describes many ingenious tools for boring, tapping, diving and drawing screws easier and quicker. Send postal for it today.

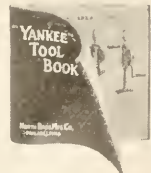

NORTH BROS. MFG. CO., Philadelphia

"YANKEE" TOOLS

Make Better mechanics

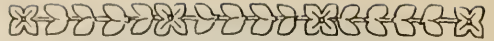

FIELD NOTES (Continued)



Kewaunee

Manual Training Equipment

The best in America—manufactured not for a "carpenter shop," but for a school teaching ideals as well as craftsmanship—yet sold at a fair and "competitive" price—that is Kewaunee.



Manual Training Bench No. 1904
Has accommodations for three students.

The Kewaunee Book will interest Educational Executives who are considering the installation of new manual training equipment. Illustrates and describes our complete line and explains our free planning service.

Write us at Kewaunee for your copy.

Kewaunee Mfg. Co.
LABORATORY FURNITURE EXPERTS

111 Lincoln St.

KEWAUNEE, WIS.

New York Office, 70 Fifth Avenue

BRANCH OFFICES:

- | | |
|-----------------|---------------|
| Chicago | Little Rock |
| Minneapolis | Denver |
| Phoenix | Houston |
| Kansas City | Spokane |
| Atlanta | Oklahoma City |
| Alexandria, La. | Jackson |
| Columbus | Los Angeles |
| Toronto, Can. | |

dows of the Albany Hardware & Iron Company. In referring to this exhibit the *Albany Journal* says, "The 'by-products' of the 'products' are shown. The products are the boys attending the school who are being taught the basic principles of a trade. The by-products are the things which these boys are making." Among these by-products are a 12-inch engine lathe, a grinder, mahogany library table lamp, samples of printing, etc. E. A. T. Hapgood is the director of the vocational school work in Albany.

THE BOARD OF EDUCATION in Niagara Falls, N. Y., is planning to build two junior high schools. Beginning next September vocational education will be a part of the regular school curriculum.

THE NEW YORK STATE Department of Education is co-operating with the New York state normal schools this summer in organizing professional improvement courses for elementary teachers and supervisors of elementary education who desire to prepare themselves to carry on more effectively their work in drawing and handwork in the grades.

The courses aim to acquaint each student with a practical working program of instruction in industrial arts. One problem before the class is the development and actual carrying out of a course of study. The time given to class work is divided between subject-matter and handwork. It is another purpose of the course to emphasize the importance of making all of the art and manual work educational and of providing that this educational experience contribute to the more effective carrying out of the entire elementary course of study.

THE INDUSTRIAL PROGRAM of the public schools of Kansas City, Missouri, is handled by a corps of special teachers, numbering fifty-two men and fifty-two women.

NEW ENGLAND ITEMS

ELLSWORTH M. Longfield, an instructor in sheet-metal work in the Boston Trade School, has severed his connection with that school and is now associated with employee training in the Schenectady, N. Y., plant of the General Electric Company. Over 23,000 employees are on the payroll at this plant, and from this fact it may be seen that in assuming his new duties Mr. Longfield faces a task of considerable proportions. The first assignment will mean that a large force of skilled men must be given a comprehensive course of training to qualify them as future instructors, and following this step will come the general training for the great mass of employees.

TURNED FROM BEAUTIFUL BLACK WALNUT



A SET OF PATTERNS AT COST

SQUARE BLANKS, selected and sawn to develop the "figure" either in "curly" or Circassian, for dresser or Vanity Cases, can now be had in sets of four or multiples of same at the same prices as for lots of one dozen.

Delivered Free in the U. S. A.

Write for List 46

Manufactured by **FRANK R. PORTER** WASHINGTON, D. C

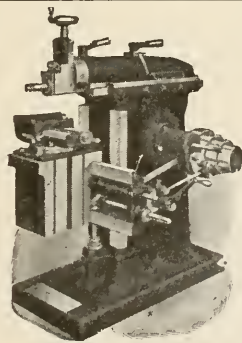

Steptoe SHAPERS and MILLERS

Steptoe Shapers and Millers are used in a large number of school shops because they are easy to operate and practically fool proof.

Send for our catalogue and learn more about the machines built by a firm with 75 years of experience in the manufacture of high grade tools.

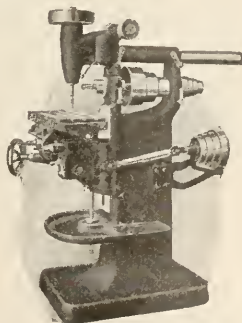

**THE
JOHN STEPTOE
COMPANY**

Industrial Education
Department
CINCINNATI, OHIO

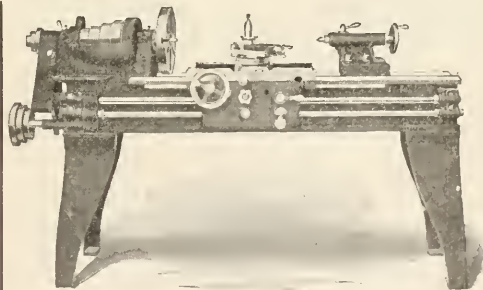

**COMPLICATED MACHINERY
is not adapted for school work**

STANDARD ENGINE LATHES

are of simple design, combining accuracy with the highest quality of workmanship and materials.

Send for descriptive matter of this medium price machine which has been especially designed for school work.

"QUALITY WITHOUT FRILLS"
Sizes 14"—16"—18"—20"

THE STANDARD LATHE WORKS
2951-61 Colerain Ave. CINCINNATI, OHIO

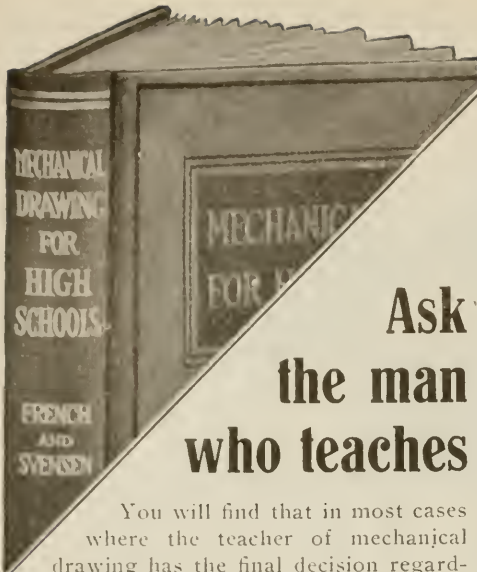

Ask the man who teaches

You will find that in most cases where the teacher of mechanical drawing has the final decision regarding his textbook, his choice is

French and Svensen's Mechanical Drawing for High Schools, \$1.50

This means one thing surely: That teachers of mechanical drawing regard this book as an especially teachable and authoritative text.

We are assured that it marks a great forward step in the teaching of mechanical drawing.

It is a complete textbook and a complete problem book in one.

If you have not yet seen the book, we urge you to fill in and mail the coupon below now.

JUST OUT!

Longfield—SHEET METAL DRAFTING, \$2.25

FREE EXAMINATION COUPON

McGRAW-HILL BOOK CO., Inc.
370 Seventh Ave., New York

You may send me on 10 days' approval

.....
.....

I agree to pay for the book or return it postpaid, within 10 days of receipt.

Signed

School

Official Position

Address

.....

M. T. M. 8-1-21

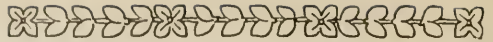

FIELD NOTES—(Continued)

James A. Booth is now carrying on the sheet-metal work at the Boston Trade School in place of Mr. Longfield.

AN INTERESTING and instructive exhibit of project work was recently held at the Boston Normal School under the direction of Miss Florence O. Bean, first assistant in the Department of Manual Arts, Boston.

For several semesters Miss Bean has been giving professional improvement courses under direction of the Boston School Committee, and the exhibit referred to was the result of an intensive study of the project method in elementary manual training.

The pupils of the classes represented developed and completed a large number of very unique and interesting projects, showing a close relation to their classroom studies in geography, history, literature, nature study, language, etc., and these subjects lent themselves very appropriately to ideal combinations for stimulating interest in each subject.

A great variety of materials was used to illustrate an equal variety of subjects, such as "Pilgrims Going to Church," "The First Thanksgiving," "Robinson Crusoe," "An Indian Village," "Our National Holidays," "A Cotton Field," "A Japanese Village," "A Pilgrim Kitchen," etc.

The planning and craftsmanship evidenced in these projects were highly creditable to teachers and pupils alike.

A considerable portion of this exhibit has been placed in the Boston Public Library, which has co-operated most heartily in an endeavor to lend greater publicity to many phases of the work of the Boston Schools.

AN EXHIBITION of unusual interest has been held at the North Bennett Street Industrial School, Boston, under the auspices of its Board of Managers. The articles exhibited included priceless pieces of furniture, sculpture, painting, tapestry, etc., and were collected for the purpose by Mr. Angelo Lualdi during a six-months' trip through the hill towns of Italy. Virtually the entire collection has been sold to connoisseurs and others appreciative of these wonderful specimens of the antique in the arts,

TOOLS

For Manual Training Shops.
Send your inquiries to and get the especially low prices quoted by

MONTGOMERY & CO. Inc.,
105 Fulton Street New York City



THE VERY BEST

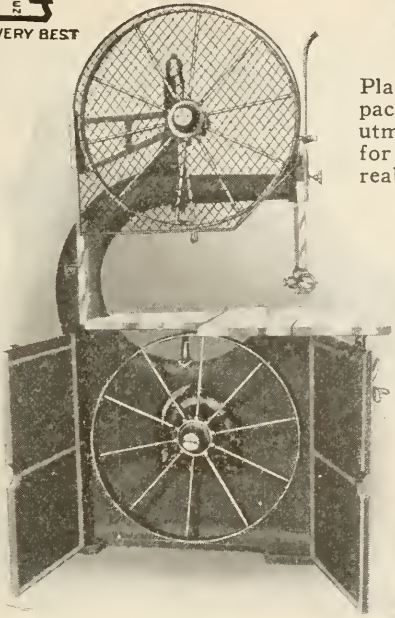

West Side

Plain, symmetric, a model of concise, compact design, a West Side band saw offers utmost capacity for good work. A machine for every purpose, each possessing very real advantages.

We would particularly direct attention to the uncommon strength of our band saws. They are of liberal proportions where the strain comes.

A New Motor Driven 36" Band Saw

—shown to the left. Most convenient of all to use. Its every adjustment is reached without change of position for the operator. Write us for information. Direct motor drives—belt drives—gear drives.

WEST SIDE IRON WORKS

Factory: Grand Rapids

General Offices:

1222 Washington Blvd., Chicago

Specialists in
Manual Training Lumber

Maisey & Dion
Hardwoods

KILN DRIED AND AIR DRIED

OFFICE & YARDS 2349 TO 2423 So. LOOMIS ST.

TELEPHONES

CANAL 1830

CANAL 1831

CANAL 118

CHICAGO

THE

Great Central Market

THE STUDENT NEEDS PRINTING

As much as he needs the alphabet. It is as much a part of education as English, the Rule of Three, and History. It is, in fact, a combination of all studies—a practical illustration of all the student learns from teachers and books. It is at once a science, an art and an occupation. It gives manual, mental and moral training. It helps form habits of industry, accuracy and taste. It is a joy to the learner and a splendid asset in every relation of life. It correlates school work.

We supply printing outfits for schools, and give the benefit of our experience and that of schools which have tried out the plan.

No school is complete and doing its best work, or near its best work, unless printing is a part of its equipment.

Send to us for help in your problem.

Barnhart Brothers & Spindler
TYPE FOUNDERS

Chicago Washington Saint Louis Dallas
Kansas City Omaha Saint Paul Seattle



STANLEY "Everlasting" Chisels

Blade, Shank
and Head,
One Piece
of Steel



In all styles of "Everlasting" Chisels, the blade, the shank and the head are a single piece of solid steel—a patented feature which not only assures greater strength and durability, but also permits the transmission of the *full* force of a hammer blow to the cutting edge of the tool.

The leather washer placed between the upset head and the handle, acts as a cushion to prevent splitting. The brass ring driven into the handle, provides an additional safeguard.

*Send for complete
tool catalog.*

THE STANLEY RULE & LEVEL PLANT.
THE STANLEY WORKS
NEW BRITAIN, CONN. U.S.A.

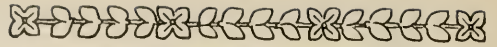

FIELD NOTES—(Continued)

and part of the proceeds of the sale have been devoted to furthering the work of the school, which, under the able direction of George C. Greener, is performing a much appreciated work in Boston.

AT A RECENT MEETING of The Vocational Education Society of Boston the members were addressed by Edward D. Dee, director of Foreman Conferences, and Charles K. Tripp, superintendent of apprentices, both of the General Electric Company, Lynn, Mass. "Foreman Training" and "Corporation Schools" were the respective subjects of the addresses, which dealt with the necessity for a comprehensive business and general administrative training for foremen, and for a well-balanced type of industrial and intensive academic training for apprentices.

Mr. Dee spoke on "Foreman Training," or, as he preferred to call it, "Foreman Conferences."

The importance of the foreman in an industrial organization was realized for the first time during the war. It was found that large projects and efficient production could not be approximated except thru his help, and that his help could not be obtained unless he had been given training or had been brought in to conferences with his fellow foreman and the management. Industrial plants generally appreciate this fact today, and the more progressive plants are taking means to do this thing.

There are four objectives of foreman conferences according to Mr. Dee: 1st, to develop a common language; 2nd, to set up a definite form for analyzing processes; 3d, to compel active thinking on the discharge of actual responsibilities; and 4th, to build up a closer co-operative spirit among the foremen.

The scope of the work is with the entire executive force. His work began with the heads of departments and later reached down to the foremen, assistant foremen, and will later deal with the "leading hands."

The method used is that of the round table discussion.

Much stress is put on the foreman's analyzing his duties and responsibilities. They are taken up as related to (1) materials—in stock, in process of manufacture, finished; (2) processes; (3) men, their mental and physical conditions.

The general result of the work according to Mr. Dee is a better spirit thruout the entire organization. It develops an appreciation among the foremen of the necessity of getting out production efficiently, at a low cost and on time and in proper quantity.

Mr. Tripp spoke on "Corporation Schools." He



Freehand sketching affords an opportunity to test the uniformity of your pencil. To produce curving lines which are symmetrical and of uniform thickness and shade, the steady hand must have the aid of a pencil that is absolutely dependable.

Dixon's Eldorado, in any degree of hardness or softness, will help you do the kind of work of which you will be proud.

SAMPLE OFFER TO TEACHERS

Dixon's Eldorado is made in 17 leads. Tell us whether you teach mechanical or freehand drawing and we will mail you suitable samples.

DIXON'S ELDORADO

"the master drawing pencil"

Joseph Dixon Crucible Co.

Pencil Dept. 19-J

Jersey City, N. J.

Cedar Chest Material

**Selected Aromatic Red Cedar of
Beautiful Grain and Texture**

Our lumber is bought direct from the mills in Tennessee, is seasoned especially for cabinet work and is matched to show the proper harmony of color.

Our model provides great range in construction and detail.

Parts are of larger dimension than needed, allowing sufficient for waste.

Price, without tray, \$16.00.

Price, with tray, 17.25

Above prices, F.O.B. Indianapolis, Ind.

**INDUSTRIAL BOOK AND
EQUIPMENT COMPANY**

Indianapolis, Indiana



Manual Training Bench, No. 16

which is furnished with one Abernathy Rapid Acting Vise, and with one drawer.

Ask for our new Catalog No. 27

C. CHRISTIANSEN

BENCH MANUFACTURER

2814 W. 26th St.

CHICAGO, ILL.

SIMONDS SAWS

When you buy new saws for Manual Training or Vocational Schools before the schools open this Fall you will make no mistake if you equip with Simonds Hand Saws. They are made of tough, edge-holding steel by expert saw makers and cost no more than some inferior brands.

They are backed by the fullest guarantee.

Write us about your requirements

Simonds Manufacturing Co.

"The Saw Makers"

Fitchburg, Mass.

Chicago, Ill.

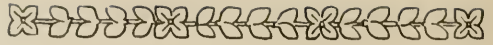

FIELD NOTES—(Continued)

confined most of his remarks to the apprentice school altho he called attention to the various schools which are supported and conducted by the General Electric Co.

A recent extension of the schools of the company is the co-operative work being done with students from Massachusetts Institute of Technology which Mr. Tripp spoke of as very successful.

—FRANCIS L. BAIN.

TRADE NOTES

THE J. A. Fay & Egan Company of Cincinnati, Ohio, have the right idea in their new catalog, *Woodworking Machinery for Manual Training*. Not unlike the usual catalog, it shows the well-known line of machines manufactured by this firm, but gives in addition much information helpful to the teacher or supervisor planning equipment. For example, included in the illustrations, which are abundant, are photographs of the interiors of school shops, showing equipments installed and in use. These photographs are clear and give the reader a good idea of the space required and the relative positioning of machines as set up in many of the schools in various parts of the country. The J. A. Fay & Egan Company is not a new concern, having been established in 1830. Their executive offices and works now occupy three entire city blocks. Ninety-one years of experience enters into the design and manufacture of their manual training machines.

Their line, as shown in this catalog, is complete, including their well-known No. 400 wood lathe, engine lathes, variety saws, universal saw benches, band-saws, planers, jointers, surfacers, etc., etc. The catalog is 5 $\frac{1}{4}$ x7 $\frac{3}{4}$; contains 108 pages; is well printed on good paper; and attractively bound. Send for a copy of this catalog if you are planning new equipment.

A NEW TOOL

If you are having difficulty in cutting belting, brake lining, or other such material you will be interested in a new tool for this purpose, called the "Yankee" Cutter No. 2,000. It is a powerful and substantial little tool designed to give a quick, clean and easy cutting of brake lining and belting of all kinds up to six inches wide and three-eighths inch thick. It consists essentially of two knives of highest grade steel carefully ground and fitted and strongly mounted. The bevel and cutting angle of the knives are the result of careful study and ex-

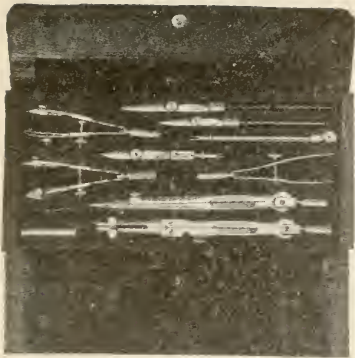

ORDER NOW—DIRECT FROM US
Mechanical Drawing Instruments
 AT OUR ATTRACTIVE WHOLESALE PRICES
 AND SAVE ONE-HALF OF RETAIL PRICES

Set of Instruments as per Photo \$6.00

Construction of Solid Nickel Silver and Steel—Pocket Case 8½ Inches by 4 Inches, and Lined with Velvet. A Set of Instruments Every Manual Training Student Can Afford—at a Big Saving and Perfect Satisfaction Send for Catalog on Other Sets, Etc.

National Instrument Company

4700 North Hamilton Ave., Dept. M., Chicago, Ill., U. S. A.

V. & B. Tools

A Complete Line of Hammers, Braces, Planes, Saws, Drivers, Pincers, Bits, Etc.



ALL V. & B. TOOLS ARE INDIVIDUALLY TESTED.

Write for Complete Circulars.

Vaughan & Bushnell Manufacturing Co.

2114 Carroll Ave.

CHICAGO

AMERICAN

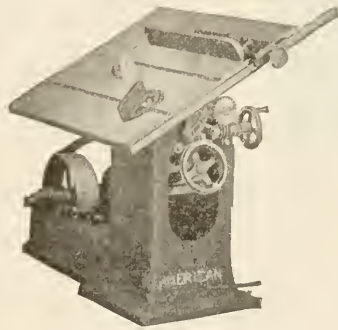

Variety Saw Table

One of Several Types of Machines Suitable for School or Shop

Also

BAND SAWS, PLANERS, JOINTERS, VARIETY WOODWORKERS, LATHES

High Grade Machines for Manual Training Schools at Moderate Prices

AMERICAN SAW MILL MACHINERY CO.

142 Main St., Hackettstown, N. J.

LUFKIN

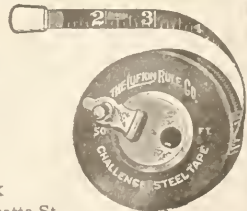
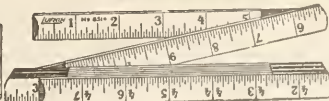
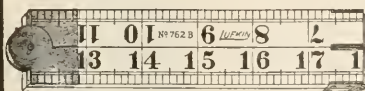

STEEL and WOOD RULES - - MEASURING TAPES

Complete high grade lines

SPECIFY—**LUFKIN**

On Sale Everywhere. Send for Catalog.

THE LUFKIN RULE CO. Saginaw, Mich.

New York

No. 106-110 Lafayette St.

Tools for Sheet Metal Work

Manual training, vocational and technical schools are invited to communicate with us regarding equipment of shops for sheet metal work, the importance of which is constantly increasing, owing to the popularity of sheet metal as a substitute for other materials.

Ask for catalog M T 56.

NIAGARA MACHINE AND TOOL WORKS
BUFFALO, N. Y.

Manufacturers of
MACHINERY FOR WORKING SHEET METALS

MITER SAW BENCHES

The "Tannewitz" Universal Double Revolving Arbor Saw Bench with Sliding Table and Taper Pin Gauges is the only logical tool for the wood shop where frequent setting up is the rule and accuracy is the goal. Send for bulletin.

THE TANNEWITZ WORKS
GRAND RAPIDS, MICH.

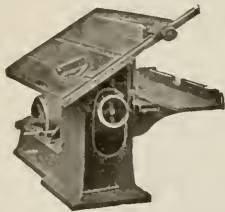
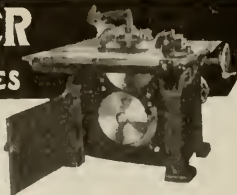

Crescent Wood Working Machines

are the tools your students will eventually use so give them the opportunity now of learning about this splendid line of wood working machinery.

Send today for our catalog of band saws, jointers, saw table, shapers, variety wood workers, planers, planers and matchers, cut off saws, disk grinders, borers, hollow chisel mortisers, Universal wood workers.

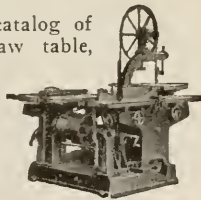

The Crescent Machine Co.

46 CHERRY ST. LEETONIA, OHIO

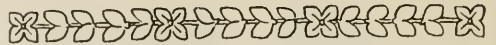

TRADE NOTES—(Continued)

periment. Power is secured thru a rack and pinion movement operated by a lever. The tool is strong and durable, and, in use, gives a clean cut with ease of operation.

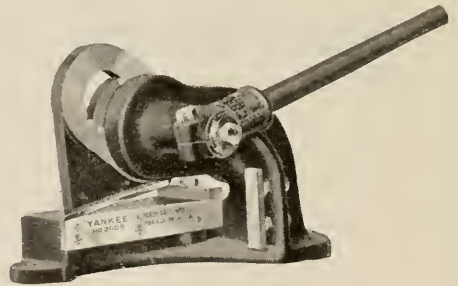

This unique tool is manufactured by the North Bros. Mfg. Company, Philadelphia, who no doubt would be glad to send illustrated descriptive matter to those interested.

CABINET CLAMPS

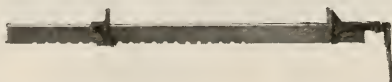

Where Black Bros. Clamps are known there is no Second Choice.

KNOW THEM

Send for bulletin today.

THE BLACK BROS. CO.
Mendota, Ill.

Build Your Own PHONOGRAPH

Instructive—arouses pupils enthusiasm—provides one of the best problems in cabinet making.

Let Your Pupils Build
Choraleon Phonographs

We furnish plans, blue prints, motors, tone arms, case material—in fact, everything required. Full instructions. Choraleon's have fine tone. Play any record. Ask for particulars.



CHORALEON PHONOGRAPH CO.
821 7th St., Elkhart Ind.



BOOK NOTES

NOW that the world is more or less at peace and business conditions are becoming more stable, the Manual Arts Press is assuming that the present is a favorable time to carry forward with renewed vigor its plans for meeting the requirements of manual arts and vocational teachers for more and better books. The development of vocational schools and classes, the enrichment of manual arts instruction in elementary schools, the new impulse now manifesting itself in the junior high schools and the coming of continuation schools,—all contribute to a larger demand for textbooks for students and handbooks for teachers that are both technically correct and pedagogically satisfactory. Recognizing these conditions the Manual Arts Press is making plans to publish during the coming year a larger number of books than ever before, in the same period of time. These are being selected and edited with special care and will be offered to the profession as rapidly as possible. Among those that are now well under way and are likely to appear during the fall months are the following:—

1—*Art and Education in Wood Turning*, by W. W. Klenke, instructor in the Central Commercial and Manual Training High School, Newark, New Jersey. This book has a very definite purpose. The author's statement of it is as follows: "This book is intended primarily for the use of students in normal schools, high schools, colleges or similar institutions and for lovers of all things useful and beautiful in wood-turning. It is a textbook and problem book combined and is comprehensive enough to cover the needs in any high school."

The author wishes to have his book stimulate a better type of design for wood-turning in schools. This viewpoint is expressed in the following statement: "It is too obvious to need mention that the general standard of woodturning design, whether in school or in the shop, is far from what it might be. This lack of good design is to some extent due to the fact that we elaborate or display our skill too much, believing that wood-turning is the cutting of a mass of beads and coves, all without a meaning." He then proceeds to indicate how the principles of design should be applied in wood-turning, and his problems embody these principles.

2—*Farm Mechanics*, by Fred D. Crawshaw formerly professor of Manual Arts, University of Wisconsin, and E. W. Lehmann, associate professor of agricultural engineering, University of Missouri. This will be the most comprehensive and detailed book in its field. It includes (1) woodwork, (2)

cement work, (3) metalwork, (4) farm machinery, (5) belts and belting, (6) farm home sanitary equipment, and (7) rope work. It will be profusely illustrated with working drawings, diagrams and photographs. It will supply the growing need for a textbook for agricultural and community high schools, and for a handbook of tool processes for the use of farmers and anyone having to do with a great variety of elementary mechanical processes.

3—*School Shop Installation and Maintenance*" by Leon S. Greene, assistant professor of manual arts, University of Wisconsin. For many years this book has been needed. It brings together selected facts known to engineers, and many more known to expert mechanics, and presents them from the standpoint of one who is acquainted with school shop conditions and the needs of teachers who are called upon to equip and take care of school shops. Power transmission, motors, installation of machinery, saw fitting, brazing band-saws, belting, babbiting, etc. are included in the volume. It will be a handy book for any shop teacher.

4—*Practical Electricity for Beginners*, by George A. Willoughby, supervising engineer, Arthur Hill Trade School, Saginaw, Michigan. This is a remarkably simple, interesting and clear presentation of the fundamental facts and principles of electricity. It has been written to meet the needs of boys of junior high school age whether in school or at home. It is in excellent form for textbook use, there being a summary of principles and a list of appropriate questions at the end of each chapter. It is illustrated by a large number of diagrams prepared by the author. The writing of the book was the result of experiencing a need for such a book while teaching boys.

5—*Chip-Carving*, by Harris W. Moore, supervisor of manual training, Watertown, Mass. The hospital work in connection with the World War has created a demand for a small book on chip-carving, brought up to date. This has been met by Mr. Moore. The book contains full-size drawings of a variety of comparatively simple objects, made more attractive by simple carving. This carving, however, is not all of the usual "chip" variety, tho it is all accomplished with the cuts of a chip-carving knife. New, or at least different cuts are utilized in many of the pieces so that the carving takes on a new variety which will be as suggestive to teachers of manual training in the schools as to teachers of therapeutic handwork in hospitals.

MAYDOLE HAMMERS

THE WORLD'S STANDARD

Highest Quality Steel Handled Hammers
Guaranteed First-Class in Every Respect

*Booklet of Useful Information
for each student on request.*

The David Maydole Hammer Co.
Norwich, N. Y., U. S. A.



SIMPLIFY GRINDING

With Mummert-Dixon Oilstone Grinders. Five wheels for almost every class of grinding. They accomplish the work quickly and accurately. With this machine your students can experience the pleasure of sharp tools.



The Modern
Edge Tool
Sharpening
Machines.

The
Standard
for all
Industrial
Schools

Five
Leading
Features
Coarse Oilstone
Wheel
Fine Oilstone
Wheel
Emery Wheel
Grinder
Cone
Leather
Wheel

Furnished for motor drive or with counter-shaft
Send for full descriptive bulletin
MUMMERT-DIXON CO., Hanover, Pa.

SAW TABLES

For MANUAL TRAINING

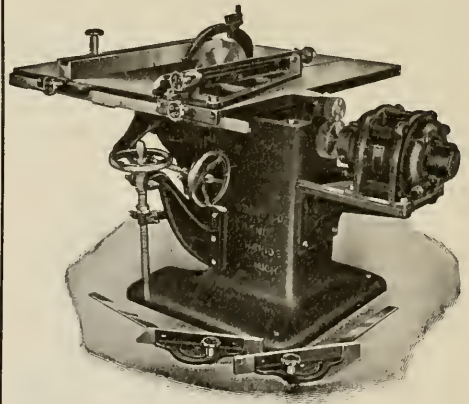

This cut shows our motor driven spiral gear saw table. No countershaft, no belts. Tilting or stationary tops. Write for circular and prices on our entire line. Address

ALEXANDER DODDS CO.
451-453 Monroe Ave., N.W.
GRAND RAPIDS, MICHIGAN, U. S. A.



MINUSA

(Trade Mark)

DRAWING INSTRUMENTS

MADE IN U. S. A.

Modern American methods of quantity production have enabled us to place on the market this line of drawing instruments (which possess a high degree of excellence) at a price within the reach of the Manual Training Student.

PERFECT SATISFACTION AT MODERATE COST
Price list sent on application.

KEUFFEL & ESSER CO., HOBOKEN, N. J.

MANUAL TRAINING MAGAZINE

EDITORS CHARLES A. BENNETT, Peoria, Illinois.

WILLIAM T. BAWDEN, Assistant to Commissioner of Education, Washington, D. C.

ASSOCIATE ARTHUR D. DEAN, Professor of Vocational Education, Teachers College, New York City

EDITORS FRANK M. LEAVITT, Associate Superintendent Public Schools, Pittsburgh, Pa.

WILLIAM E. ROBERTS, Supervisor of Manual Training, Public Schools, Cleveland, Ohio.

Business Manager L. L. SIMPSON.

Published monthly by The Manual Arts Press, 237 N. Monroe St. Peoria, Illinois.

Subscription Price, \$1.50; Canada, \$1.80; Foreign, \$2.00. Single Copies, 25 cents; Foreign, 30 cents.

Subscriptions, remittances, and manuscripts should be sent to THE MANUAL ARTS PRESS, Peoria, Illinois.

CONTENTS

PRACTICAL ARTS FOR VOCATIONAL GUIDANCE IN THE JUNIOR HIGH SCHOOL.....	<i>John M. Brewer</i>	69
MANUAL ARTS IN THE JUNIOR HIGH SCHOOL.....	<i>Charles A. Bennett</i>	73
THE SELECTION OF PROJECTS FOR A MECHANIC ARTS COURSE (Illustrated).....	<i>J. N. Baker</i>	77
SHOP ORGANIZATION AND CARE OF EQUIPMENT (Illustrated).....	<i>DeWitt Hunt</i>	81
EDITORIAL REVIEW FOR THE MONTH.....		86
Americanization—Illinois Drops Behind—The New President of the Western Arts Association—Use of Industrial Films.		
A POINT OF VIEW.....	<i>Arthur Dean</i>	89
WASHINGTON CORRESPONDENCE.....		92
A Legislative Tangle—Changes in the Federal Board Personnel—Mr. Hawkins goes to the U. T. A.		
IN FOREIGN COUNTRIES.....		94
The Discovery of Aptitude a First Step in Education—The Oneness of Education—Certification of Handicraft Teachers.		
PROJECTS, PROBLEMS AND NOTES.....		96
Elementary Woodworking Problems from St. Louis—A Steel Hardening Tester Magnet—Machine Shop Problems—A Printing Project.		
CURRENT PUBLICATIONS.....		105
FIELD NOTES.....		IV
A Survey of Technical Training in High Schools, Newark, N. J.—Around New York—Southeastern Items—From Pennsylvania—From the North—Vocational Center at Nauvoo, Ill.—Report of Part-Time Schools—U. S. Chamber of Commerce Calling for Better Schools.		
TRADE NOTES.....		XXVIII
BOOK NOTES.....		XLI

This Magazine is kept for sale at McClurg's in Chicago, and Brentano's in New York.

Entered at the Post Office at Peoria as Second-Class Matter. Copyright, 1920, The Manual Arts Press.

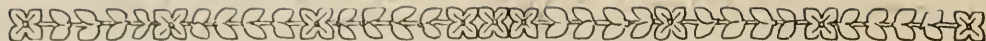

FIELD NOTES

A SURVEY OF TECHNICAL TRAINING IN HIGH SCHOOLS, NEWARK, N. J.

AT A MEETING of the Newark Board of Education held February 23, 1921, Superintendent David B. Corson requested an appropriation of money to defray the necessary expenses of a study he was making of the question of removing or retaining the technical curriculum in the commercial and manual training high schools. In presenting this request Dr. Corson made a brief statement of the problem. In part he said:

"In the program of studies of two of the high schools there is a curriculum known as the technical curriculum. It provides work in joinery, sheet metal, pattern making, forge and foundry, machine shop, and mechanical drawing. The curriculum has a double objective: first, to prepare boys to enter the industries; second, by substituting foreign language for shop work, to prepare boys for admission to engineering schools.

"The Board of Education is now erecting an 800-pupil vocational school for boys at a cost of more than a million dollars. The purpose is to provide full opportunity for vocational education, the Boy's Vocational School having outgrown its accommodations.

"The question is: Shall the technical curriculum be continued in the two high schools? There are arguments which seem to justify a negative answer to the question. One of these is that the time is insufficient for pupils to acquire the skill of the apprentice, and another that the engineering colleges prefer to have academically trained rather than shop trained pupils. There are, however, convincing arguments in favor of an affirmative answer."

The appropriation for this study was granted and, at the request of Dr. Carson, Dr. David Snedden of Columbia University assisted in the study and investigation of this problem. Dr. Snedden's findings supported the position that the technical courses with the two objectives should be retained in the technical high schools.

A portion of Dr. Snedden's report as submitted, follows:

I. THE GENERAL SITUATION

"The general secondary situation in Newark is not greatly different from that of certain other industrial and commercial cities, the schools of which I have examined. I refer especially to Boston, Buffalo, Los Angeles, Kansas City, Cleveland and Detroit. In each of these cities there was established some years ago one or more technical high schools (otherwise called "manual training," "me-

chanic arts," or "polytechnic" high schools). The expectation on the part of some influential citizens and of some educators, certainly, was that these non-academic, shop-equipped high schools would meet local needs for the training of artisans and the "non-commissioned officers" of industry. A careful study of the aims and accomplishments of one such school (The Mechanic Arts High of Boston) by C. A. Prosser, for some years chief executive of the Federal Board for Vocational Education, was published in 1915. That the technical high schools of the cities named serve the purposes of good general high schools, I think no one would dispute.

But it is certain that very few if any competent authorities will now contend that these schools are more than incidentally vocational. The best authorities on vocational education will, I am confident, assent to these propositions:"

II. FINDINGS AND GENERAL RECOMMENDATIONS

"In view of the experience of other cities as well as of local conditions in Newark, I submit, in answer to your question "shall we continue the technical course in the two high schools?" the following statements combining findings and recommendations:

"Technical courses, perhaps differing in some respects from those now offered, should be continued in such high schools of Newark as now have them, but it should be clearly understood that such courses are offered primarily because of their value for general, rather than for vocational education. Since the character of the equipment used, and the amount of time now given, in some of the shop courses (notably the machine shops) have been affected by earlier intentions of giving specific industrial training which are not, and, under the conditions, cannot adequately be realized, reductions and simplifications of shop work in technical courses might well be contemplated. The foregoing conclusions rest on these considerations:

a. Shop courses of certain kinds do make contributions to the general education of certain types of boys (and girls also) no less important than the more academic courses.

b. But for purposes of general education shop courses should probably consist largely of hand work, supplemented by just sufficient experience with power driven machinery to develop appreciations of what various machines are for and of their general character.

c. Shop courses should not resemble those laboratory courses in physics, chemistry, etc., which are designed to extend general experience, to de-

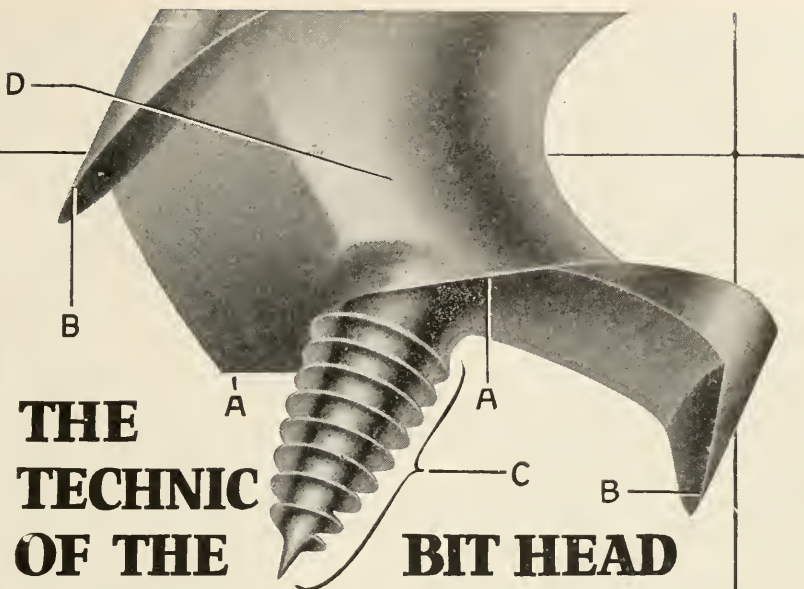

THE TECHNIC OF THE BIT HEAD

THE quality of any bit is chiefly determined by the exactness with which the various essential points in the head are related to each other.

The two cutting edges (a) must be in the same plane; the spurs (b) must be of the same length and just long enough to loosen the chip; the pitch of the screw (c) determines the speed of the bit; the throat (d) must have ample clearance so it won't choke.

Every time you see an Irwin Bit check up the accuracy with which these features have been cut in the head. Compare Irwin heads with other heads. Then you will understand why the boring qualities of Irwin heads have made the Irwin Bit the most widely popular, and built the largest business in the world devoted exclusively to wood boring tools.

Your school should use Irwins. Your pupils should know the reasons for Irwin quality.

*Write for booklet on the Selection,
Use, and Care of Bits*

THE IRWIN AUGER BIT COMPANY
245 Grant Street Wilmington, Ohio

*Originators and sole manufacturers for 35
years of the Genuine Irwin Bits and Augers*

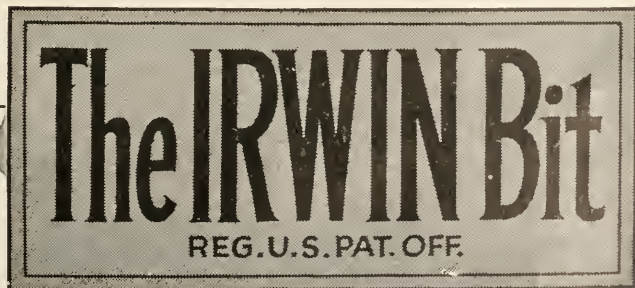

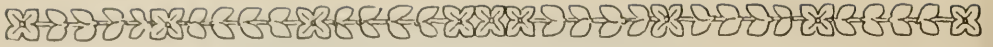

FIELD NOTES—(Continued)

velop appreciations, and to promote mechanical interests.

d. It is not essential for the purpose indicated, that shop courses employ expensive equipment, except as example for illustrative purposes.

e. All experience seems to point to the especial desirability of shop courses for boys of mechanical inclinations between the ages of 12 and 16, or corresponding to grades 7 to 10. It is doubtful if shop courses are important, except in rare instances, as means of general education for boys over 16 years of age, though pupils of this age, not having taken shop courses earlier, should always be permitted to elect courses provided primarily for young pupils.

f. Assume the case of a boy of mechanical bent who, after one or two years in the technical high school, determines to become a skilled mechanic, influenced in this perhaps by the "sampling" work he has had in the 9th and 10th grades. Has he anything to gain vocationally by continuing in the shop courses of the technical school? Probably not. He probably should, if he desires to complete a regular high school course, take up for the rest chiefly academic studies. Otherwise, he should go to trade school or enter apprenticeship.

g. The technical high school student who intends to enter college finds it necessary to replace shop work with foreign languages in the second, third, and fourth years. Such students will frequently find it desirable to prepare in at least two units of mechanical drawing. Hence only the exceptional student preparing for college can carry any considerable amount of shop work in the last two or three years of his course.

"It is of the utmost importance, in a democratic scheme of public education, that each type of school, serving worthy purposes, should be held in as high public esteem as any others, and that pupils should transfer freely from one to the other when their best interests demand it. Newark is now providing a large and well-equipped industrial school for boys in which it is designed that trades in their earlier stages shall be thoroly and practically taught. All the teachers of Newark concerned with advising pupils will be expected to support and recommend each type of secondary school, including the trade schools, without disparagement, but according to the best interests of the various types of pupils. These conclusions are therefore submitted:

a. The functions of the technical as well as of other general high schools in preparing for college and in giving general secondary education should be given clear public expression.

b. The strictly vocational character of the trade schools, as well as the essentially non-vocational character of the shop courses in the technical high school should likewise be made clear to pupils and patrons.

c. For students who have the time and interests it would be very desirable to spend two years in some high school and then, at 16 years of age, enter a trade school. But no steps should be taken to prevent boys of sufficient maturity and physical development from entering trade schools if they desire, irrespective of grade attained.

d. In view of the fact that a trade school proper should always be equipped with strictly modern machines and other tools, whereas the purposes of shop work in general education can well be served by simple standard equipment, it seems undesirable to transfer to the trade school machines and other apparatus from the technical schools even where the latter have an amount in excess of their present needs.

"The technical courses now found in the technical high schools provide that students in the third and fourth years may specialize to the extent of from one-fourth to one-third of their time on one line of shop work. The original intent of this arrangement was, doubtless, to provide for vocational specialization. But, in view of the fact that the Newark trade school will provide for the direct and positive training of machinists and other trade workers, the actual purposes and possibilities of the specialized shop training in the technical high schools should be carefully re-examined. If it is to be continued for vocational reasons the actual vocations to be prepared for, as well as the probability that pupils specializing in this shop work, will later enter these vocations should be studied. It may well be doubted whether it is profitable that public funds be invested in shop courses as a part of *general* secondary education to an extent greater than called for by five hours for a half year respectively in cabinet making, sheet metal work, forge and foundry, and machine shop, to which might be added printing and electrical work if facilities permitted. To permit a high school student, not specializing towards machine shop practice, to elect as much as forty-six half-year hours of machine shop is certainly to impose an excessive cost on the city for this type of general training."

III. SPECIFIC RECOMMENDATIONS

"In view of the foregoing considerations, and having in mind what seems to me the problems immediately confronting the school authorities of Newark, I would recommend:



“You Couldn’t Do Better, My Boy.”



“I remember when I bought my first Starrett micrometer—the pride with which I showed it to older machinists in our shop—the pleasure I got from their approval. Then, as now, Starrett Precision Tools were prized for their dependable accuracy by the ‘crack’ men in the metal-working trades.

“You couldn’t do better than to choose a Starrett Tool kit for your shop-work at ‘Tech’. The use of these tools in your engineering studies and shop practice will teach you to appreciate, as we old-timers do, the quality and accuracy that have made Starrett Tools preferred by two generations of master machinists.”

Catalog No. 22 “EF”
featuring 2100 Starrett
Tools—will be
sent free on request.

THE L. S. STARRETT CO.
The World’s Greatest Toolmakers
Manufacturers of Hack Saws Unexcelled
ATHOL, MASS.



Use Starrett Tools



FIELD NOTES—(Continued)

I. Such reorganization of the technical courses of the high schools as will:

a. Enable 1st and 2nd year students to elect courses, preferably quite flexible in nature, in several varieties of shop work. Chief emphasis should be laid upon hand work, but opportunities to witness demonstration of, and even to obtain some slight experience in manipulating related power-driven machines—lathes, planes, gas engines, dynamos, and even printing presses and steam engines—should be provided.

b. Enable students desiring trade training after their first or second years to transfer, without loss of prestige, to the industrial schools.

c. Enable students desiring to enter college or to complete an academic course to do so after their second year, without further shop work. (Note that for present purposes mechanical drawing is included in an academic course).

d. Reduce the cost of shop courses to a substantial parity with laboratory science courses in cost per pupil-hour.

II. The preparation, in booklet form, of detailed information for the guidance of citizens, parents, and pupils, as well as elementary and high school teachers, as to the respective purposes of the various secondary schools of Newark—academic, technical, and vocational. Every effort should be made thru this material and otherwise to enable parents and pupils to find the school work best adapted to the abilities, means, and prospects and, to some extent, interests, of various types of pupils."

On the recommendation of Dr. Corson these technical courses have been retained in the Newark high schools. Certain changes thought to be wise in view of the above findings will gradually be made.

—ALLEN D. BACKUS.

AROUND NEW YORK

THE New York University summer art class under the direction of Dr. James P. Haney, head of the art department of the city high schools, numbers 122 students, representing more than twenty states, together with representatives of Cuba and Canada. The students are studying modern phases of high school art teaching, and at the same time are developing in the studio of the University a large number of patterns and designs for application to material.

Over half of the students present have pursued the course in other years. The sequence of lectures takes five years to complete, and was begun in 1919. This year the emphasis is on demonstra-

tion drawing, and all the students will be trained to make large and colorful drawings direct from memory. More than thirty practical designs for different forms of material were shown in the studio on the afternoon of July 22.

"We allow no copying of motifs," said Dr. Haney. "In the collection of work shown you will see hundreds of motifs taken from nature, as these exist in patterns of shells, flowers, leaves, and a hundred other forms. Our students are taught to study nature, and to see her suggestions for patterns. These suggestions they weave into many-colored designs, as may be noted in the dozens of examples of patterns for silk printing, for applique and other textile processes."

The exhibition included a varied collection of work, all bright with color and full of interesting motifs, drawn from birds, shells, butterflies, and strange sea animals loaned for the purpose by the American Museum of Natural History.

Among the striking features of the work were the motif charts whereon students drew the birds or shells which they had studied from the standpoint of design, and under these showed pieces of patterns, single units, borders, and all-over designs, from interesting motifs which they have secured by the study of the natural form.

In addition to the gayly colored charts were the even more gorgeous examples of silk designs. These were made in a competition organized by the class. Other designs along commercial lines—posters and card advertisements—were to be found, together with many designs for costumes and stage sets for pageants.

PROVISIONS FOR NINE MORE SHOPS for manual training in the elementary schools were included in the 1922 budget. The number of shops is inadequate to accommodate the pupils entitled to shop instruction at present.

NEW YORK CITY has recently established an Art Center. It is located in the brownstone four-story houses on 65 and 67 East 58th St. It is the purpose of the founders of this institution to bring together the interests of artists, artisans, and manufacturers. This means that under one roof will be housed a variety of organizations devoted to crafts and producers. By means of exhibits, it will be possible to bring together artist and manufacturers and in this way supplement each one's views. Hitherto, the artists have hungered for lack of market, the manufacturers for lack of idealism. Furthermore, many of the large textile manufacturers are dominated by foreign designs to the extent that a plant worth millions will be

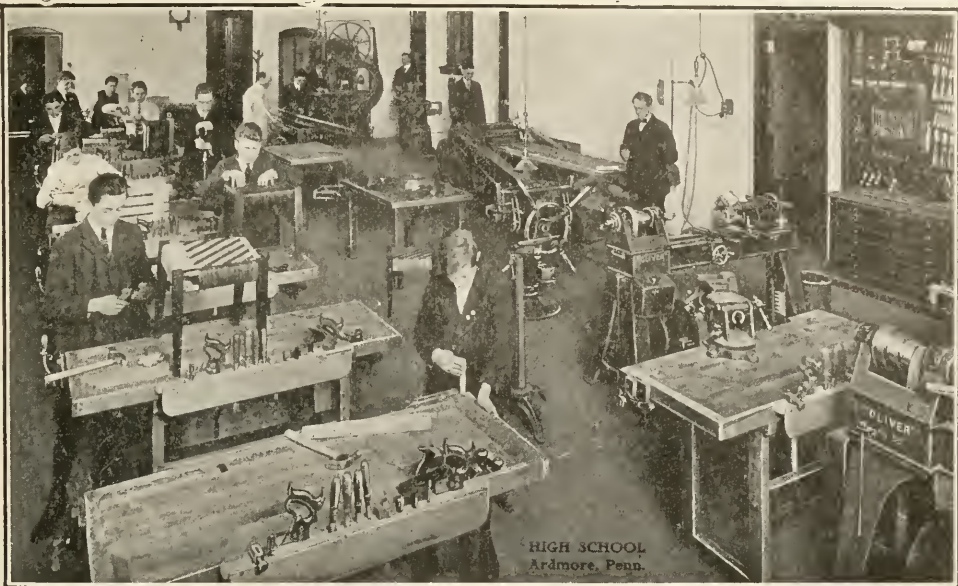

HIGH SCHOOL
Ardmore, Penn.

Over 1200 Schools Use "Oliver" Tools

The Engineers of the Oliver Machinery Co. have had experience in "laying out" both industrial and school shops second to none. Their services are at your disposal.

"Oliver" Woodworking machines are the last word in design, efficiency, convenience, economy and safety. The quality of "Oliver" machines has made an enviable reputation for "Oliver" Tools and has established them as the standard by which other tools are measured.



OLIVER No. 126 BELT SANDER

Oliver Machinery Co.
Grand Rapids, Michigan, U. S. A.
Branch Offices or Salesmen in Principal Cities



FIELD NOTES—(Continued)

ruled by designs lately arrived from Paris, while our own country's artists may be eating their hearts out waiting for Fame to brush her wings across their pictures.

UNDER THE AMENDMENTS to the compulsory education law of New York City recently enacted, the schools become directly responsible for following these young people into industry, for they cannot be discharged from school until they secure employment papers, and cannot get such papers until they get a job. The certificates which are to be issued after Sept. 1 by the Department of Education instead of by the Board of Health, are to be issued for a particular job and upon change of employment a new certificate must be issued.

The pupil must be continued on the school rolls as an absentee while seeking employment or some provision must be made for helping the pupil get suitable employment.

The local school officials have decided that the experience of the Department of Education in placing high school pupils in after-school and Saturday employment should be used in developing and centralizing placement work, and to this end a proposal has been submitted to the budget committee to provide for two bureaus, one in Manhattan and the other in Brooklyn, where trained counsellors will help guide pupils who must go to work into jobs they are fitted to fill, and, where possible, to make arrangements for them to remain at school. All of the employment or placement work in the schools will clear thru these central offices, and the teachers in the schools who are now serving part-time as advisers, will be relieved of that service. It is figured that more effective work will be done at less cost.

Summer, after-school, and Saturday employment work now being cared for by special budget provisions will all clear thru this new bureau. The proposal is now pending before the budget committee of the Board of Education.

WM. H. DOOLEY.

SOUTHEASTERN ITEMS

THE South, as well as other sections, has felt the effects of the readjustment period quite severely. The low cotton and tobacco markets in connection with the small demand for the finished product manufactured from these raw materials, has brought about conditions not at all pleasant. When a group of people are seriously interfered with in an industrial activity other activities suffer also.

G. W. Coggin, state supervisor, made the follow-

ing statement relative to conditions in North Carolina: "In many respects we have had quite an up-hill pull as the dullness in the financial and industrial world during the year has caused many to pause and wonder if it were worth while to get ready for a job, when they saw wages going down so rapidly and so many men being laid off from jobs for which training was offered.

"On the other hand, it has been very clearly demonstrated that the men who were best fitted were the last to be dropped from the pay rolls, and that the wages which had shot up so high for unskilled labor dropped just as quickly as they went up. Some seeing this took greater interest than formerly in our industrial classes.

"The day of poor workmanship is about to pass and we are facing a period when nothing but first class goods will be marketable. This, as you know, will require efficient production. 'Seconds' will have to be eliminated. This means that sharp competition will cut down the margin of profits so that only the efficient plant as well as the skilled workman can hope to stay in the game.

"The United States was up against a difficulty during the war on account of the lack of trained men in nearly every trade. They did the apparently impossible, however, by emergency classes. This has opened our eyes and we have found that some head work and pure instruction in the 'tricks of trade' can get a man up to standard very much more quickly than the long and tedious 'hard knocks' method in which a man blindly works his way thru by 'stealing' most of the technical knowledge which he gets. Many times, by the latter method, it takes long years to learn just one trade. Many, however, learn only to operate a machine, which knowledge often becomes useless owing to an invention which displaces the machine. The day has come when a man must know more than an operation; to be independent he must know a trade.

"Much of our teaching conforms too nearly to regular school methods. We should get just as close to shop as possible: teach the men just what they need on their job, and what they have to know to run the job ahead. General information is good but the big things are efficiency on the job and preparedness for promotion."

THE FOLLOWING ADVICE was given to the teachers in Georgia. It might be applicable elsewhere also.

"Look well to the destination toward which your train is headed. How many passengers do you arrive with and at what sort of way station or cross roads do the students detain? Why do they de-

LITTLE GIANT

MANUAL TRAINING DEPARTMENT

Special Equipment

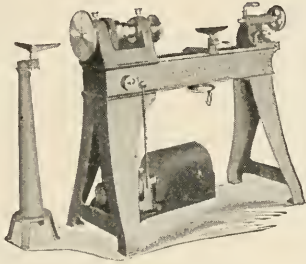

LITTLE GIANT WOOD LATHES

Individual Motor Driven, or Belt Driven from above or beneath.

Furnished with either Bench or Floor Legs. Wide choice of optional tools and equipment. Four speeds.

Many new, exclusive and practical features. All bearings are Hyatt High Duty Roller Bearings which greatly reduce power required. Ball Thrust bearings at all points of end thrust.

Sold on 30 days trial, and GUARANTEED FOREVER against defective material and workmanship.

LITTLE GIANT METAL LATHES

Individual Motor Driven, or Belt Driven from above or beneath.

Furnished with either Bench or Floor Legs. Wide choice of optional equipment. Three speeds.

Many new, exclusive and practical features are also found on our metal lathes. They are fitted to receive attachments for grinding, milling, gear cutting, etc., all of which we will furnish at a small fraction of the cost of a separate machine for such work.

Sold on 30 days trial and GUARANTEED FOREVER against defective material and workmanship.

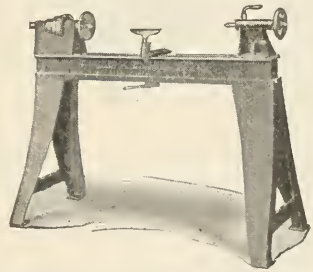

LITTLE GIANT POWER HAMMERS

Individual Motor Driven, or Belt Driven from above. Hundreds of different form-forging dies for instruction purposes.

Standard equipment with leading Technical and Manual Training Institutions.

Sold on 30 days trial, and GUARANTEED FOREVER against defective material and workmanship.



DO NOT OVERLOOK

Metal Working Equipment in your school. Wood can never be made anything else, while metal working and alloying are in their infancy.

The Industrial Leaders of the world, to a very large extent, began as metal workers.

Wood working is artistic, and trains mind, eye and hand to deftness. Metal working does all this, and more. It is also practical, and the graduate invariably finds a position waiting for him, while the wood working department graduate usually takes up something else and his instruction is forgotten.

Little Giant Equipment for Technical and Manual Training Schools consists of a full line of all metal and wood working machinery including accessories and tools for same.

On Motor Driven Equipment, information will be required as to Current, Voltage, Phase and Cycles of Motor.

Our business commenced in January, 1876, more than 45 years ago, and our Little Giant Products are used throughout the world. We are anxious to serve you for we can do it well.

Quotations and descriptive literature can be secured from any jobber, or direct from us.



LITTLE GIANT COMPANY

220 ROCK ST.

MANKATO, MINN., U. S. A.

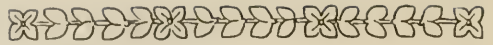

FIELD NOTES—(Continued)

train? If you operated additional trains, would more students travel? If your trains went to other stations, would not the same thing happen? Why not improve your system and put on more trains? Don't excuse yourself and hold yourself blameless or the 'blood of Abel will cry out against you.' You are the pacemakers of civilization for the entire body politic and not merely the little group that comes to you voluntarily. Are you satisfied with your present accomplishments? Are you grown, intellectually? A nice juicy plum when pulled from the tree evaporates and becomes a prune."

J. C. WRIGHT of the Federal Board, after inspecting the vocational work done in the wood pulp industry at Canton, N. C. reports that the results were highly satisfactory. The instruction was in a new field and success was due to careful organization and skillful teaching.

COLUMBUS, GA. has conducted intensive courses for instruction in the machine and building trades.

—FOREST T. SELBY.

FROM PENNSYLVANIA

THE following items are quoted from the "Continuation School Doings" of the *News Bulletin*, Pennsylvania Society for Vocational Education:

"Interior decoration has been a subject of more than usual interest in the Lancaster Continuation School. The work has been of equal interest to girls and boys. Upon solicitation by the teacher, Miss Whitson, business firms were generous in contribution of interior views, wall paper, and other materials. These views were studied, drawn and colored in water colors by pupils. Window decorations have been emphasized.

"Patience, proportion, mathematical exactness, cultivation of good taste, have been by-products resulting from this phase of drawing. Neutral colors are now appreciated more than mere display of color. The things that make for quietness and peace are now chosen in color schemes for interior decorations.

"JOHNSTOWN is combining arithmetic, geography, history, English, current events, economic sociology, and hygiene woven into a series of carefully planned project lessons. Each project usually occupies about three hours' time. These projects have been used:

- What shall I do with my money?
- How can we help make Johnstown a safer city?
- What shall I do with my spare time?
- What occupation am I best suited for?
- What shall I read?



See these books for 10 days FREE

Longfield—

SHEET METAL DRAFTING, \$2.25

A good textbook on sheet metal pattern drafting.

George—

ADVANCED SHOP DRAWING, \$1.60

Special phases of shop drawing such as pictorial representation, patent office drawings, electrical drawing, piping layouts, etc.

Moyer—

GASOLINE AUTOMOBILES, \$2.00

A concise textbook on automobile construction, operation and repair.

French and Svenson—

MECHANICAL DRAWING FOR HIGH SCHOOLS, \$1.50

The Standard text.

FREE EXAMINATION COUPON

McGRAW-HILL BOOK CO., Inc.
370 Seventh Ave., New York

You may send me on 10 days' approval

.....

.....

I agree to pay for the book or return it, postpaid, within 10 days of receipt.

Signed

School

Official Position

Address

.....

M. T. M. 9-1-21



Platen Presswork

Platen Presswork

Provides the Pupil with a Picture of His Efforts

ALL the various technical processes of printing possess fascination for the average healthy boy, but none of these processes appeal to him more than presswork. Platen presswork is the first step in producing the actual printed product. Only the purely technical and vocational printing courses include cylinder presswork, but all school equipments include platen presses.

The climax of the pupil's enthusiasm is reached when he takes the first proof of his job from the press. Here

is something he has produced with his own "hands, brain and heart." He is anxious to show it to his comrades, parents, and friends, and immediately this printed product assumes a community interest. Only those adults who have accomplished something which they consider their masterpieces can realize the joy and satisfaction of the pupil who takes his first printed sheet from the press.

If you desire to install in your schools an activity that will arouse and maintain the interest of your pupils, write to

F. K. PHILLIPS, *Manager*, EDUCATION DEPARTMENT

AMERICAN TYPE FOUNDERS COMPANY

JERSEY CITY, NEW JERSEY

BOSTON, MASS.
NEW YORK CITY
PHILADELPHIA, PA.
BALTIMORE, MD.
RICHMOND, VA.

BUFFALO, N. Y.
PITTSBURGH, PA.
CLEVELAND, OHIO
CINCINNATI, OHIO
ATLANTA, GA.
LOS ANGELES, CAL.

CHICAGO, ILL.
DETROIT, MICH.
ST. LOUIS, MO.
MILWAUKEE, WIS.
MINNEAPOLIS, MINN.
WINNIPEG, CANADA

KANSAS CITY, MO.
DENVER, COLO.
PORTLAND, ORE.
SAN FRANCISCO, CAL.
SPOKANE, WASH.





FIELD NOTES—(Continued)

How can Johnstown be made a better and more beautiful city?

What constitutes the basis of a democratic government?

Why I prefer to live in a democracy."

LUTHER H. METZGAR, of Philadelphia, was elected manual training instructor in the German township high school to succeed C. Stanley Rothenhauser who has resigned to take up similar work in Philadelphia.

Mr. Metzgar comes to German township well recommended being a graduate of Williamson Trade School in the year 1913, and having worked seven years at the trades of pattern making and carpentry.

THE BOARD OF EDUCATION of Harrisburg, Pennsylvania will soon let the contract for a new senior high school building of extraordinary proportions and arrangement. The building will be 700 feet in length and will accommodate 3,000 students. The plans will provide for a future addition to this building if necessary. The building would then take care of an additional 1,300 students. An auditorium with a seating capacity of from 2,000 to 2,500, two gymnasiums, a swimming pool, locker rooms, laboratories and shops for home economics and manual arts, and a cafeteria with a capacity of 2,000 are some of the features of this building. Close to the building will be located a large athletic field. Here will be separate space provided for foot ball, base ball, running tracks, and five tennis courts. It is expected that the construction of the building will be begun in the early fall.

The completion of this school building will increase the facilities for work in manual arts and vocational education very greatly. H. E. Todd who is the Supervisor of Industrial Education in the public school of Harrisburg, may well look forward to the enlargement of his opportunities for service in that city.

FROM THE NORTH

THE Minnesota Building Trades School which was established about three months ago by the Minnesota Building Employers' Association, a group of Minneapolis and St. Paul builders, is one of the most unique institutions of its kind. The school was started as an experiment to eliminate an acute shortage of bricklayers in Minnesota. There are now forty men taking the work in bricklaying, and plans are being made to increase the curriculum to include other trades.

A period of attendance of six months is required. A tuition fee of \$25.00 is charged but this fee is



BUFFALO equipped trade schools and manual training departments insure working under practical conditions.

Our Engineering Department will be glad to give you accurate data on blowers, exhausters, forges, drills and punches and shears.

*Write for catalogue
205-31*

Buffalo Forge Company

BUFFALO, NEW YORK

"Buffalo's"

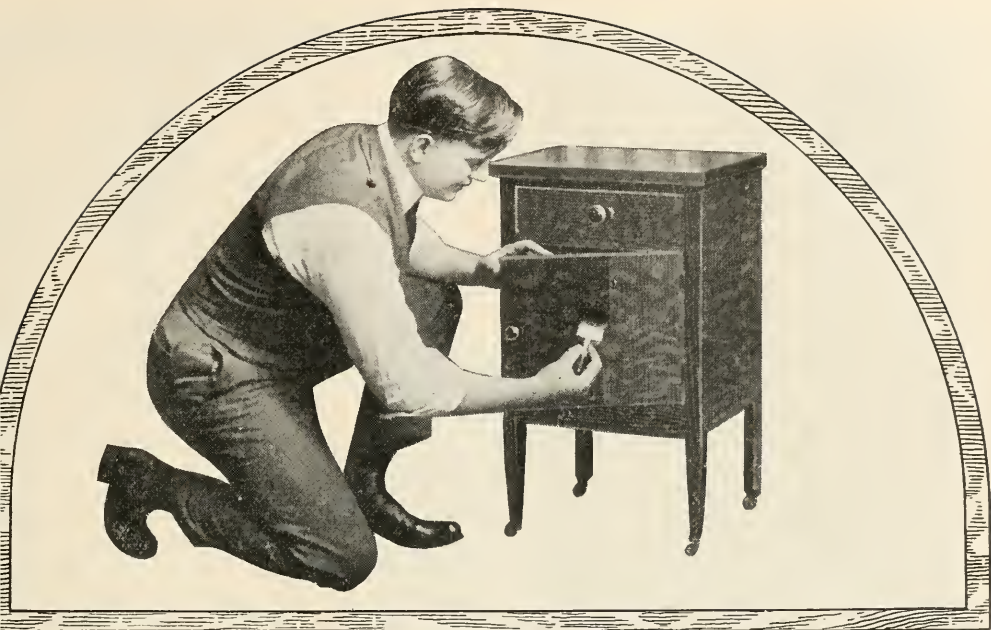

Finish It Well

THE finishing of manual training models is assuming more and more importance every year. Surely it is a subject which should be given its share of attention, for a beautiful model may be ruined if improperly finished, while the defects of a poorly constructed model are minimized if well finished.

JOHNSON'S ARTISTIC WOOD FINISHES

Johnson's Artistic Wood Finishes are now being used in nine-tenths of the schools in the Country. They are particularly adapted for manual training work as they may be applied by the youngest and most inexperienced pupils with the best results.

The Johnson Wood Finishes most popular among Manual Training Instructors and Pupils are Johnson's Wood Dye, Prepared Wax, Under-Lac, Paste Wood Filler, Flat Varnish, PerfectTone Under-pat and PerfectTone Enamel. We have a very attractive exhibit of wood panels finished with these products which we are glad to send Manual Training Instructors who will give it wall space in their shop. Write for it.

Instruction Book on Wood Finishing Free

Write for our beautiful thirty-two page color book "The Proper Treatment for Floors, Woodwork and Furniture." It is full of valuable information for Manual Training Instructors and pupils. It includes color card—gives covering capacities, etc. We will gladly send it free and postpaid for the name of your best dealer in paints.

C. JOHNSON & SON, Dept. M. T. 9, Racine, Wis.

"The Wood Finishing Authorities"

Canadian Factory—Brantford



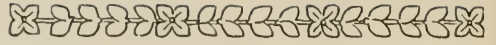

FIELD NOTES—(Continued)

returned to the students at the completion of the course. The students may apply for an efficiency test at the close of the course of instruction, and from this receive a certificate indicating the degree of skill they possess, and the initial pay they should receive when leaving school.

Three sessions are held each day—one in the forenoon, one in the afternoon, and one at night. This enables those students who wish to do so, to work a part of the day and attend a full session in the school. The builders are providing the opportunity for part-time work. The men who are selling building material are co-operating with this school by contributing the required material for the trade work.

The hope is, according to the statement of Mr. Schumacher, president of the Minnesota Building Employers' Association that this school for bricklayers will be but the first of a series of units of a school which will have a high place among the institutions of learning in the state of Minnesota.

AIR SEASONING OF WOOD. In co-operation with the sawmills and wood utilization plants thruout the country, the Forest Products Laboratory, Madison, Wisconsin, is organizing an extensive field study on the air seasoning of wood. This study, it is believed, will be of extreme interest to the lumber manufacturer and to the wood-using industries. The purpose is to determine the piling practice which will result in the fastest drying rates consistent with the least depreciation of stock, the least amount of required yard space, and the least handling costs. The study will be carried on concurrently on both hardwoods and softwoods. All the important commercial woods of the United States will eventually receive consideration. The new project will furnish a comparison of the effects of such piling variables as sticker heights, the spacing of boards in layers, the heights of pile foundations, and the directions of piling with relation to prevailing winds and yard alleyways.

A tentative working plan of the air seasoning study has been prepared by the Forest Products laboratory, and copies are being sent to the secretaries of the various lumber and wood-using associations, state foresters, forest-school heads, and others eminently qualified to comment on the plan.

Co-operation in the air seasoning study is being offered on every side. As yet the plants at which the work will actually be done have not been chosen definitely, but the extreme interest already manifested indicates that there will be no difficulty in securing co-operation with plants ideal for the study. Actual field work will soon be well under way.



GOOD TOOLS ARE ESSENTIAL FOR GOOD WORK

Since 1848 we have adhered to one policy—to handle only the very best in quality.

Our 300 page catalog illustrated above is of particular value to those interested in manual or vocational training. If you haven't a copy ask for Catalog No. 224.

**HAMMACHER
SCHLEMMER & CO.**
Hardware, Tools and Supplies
New York, Since 1848, 4th Ave. and 13th St.

The Best Method of Mortising
is Taught on

Our New No. 462

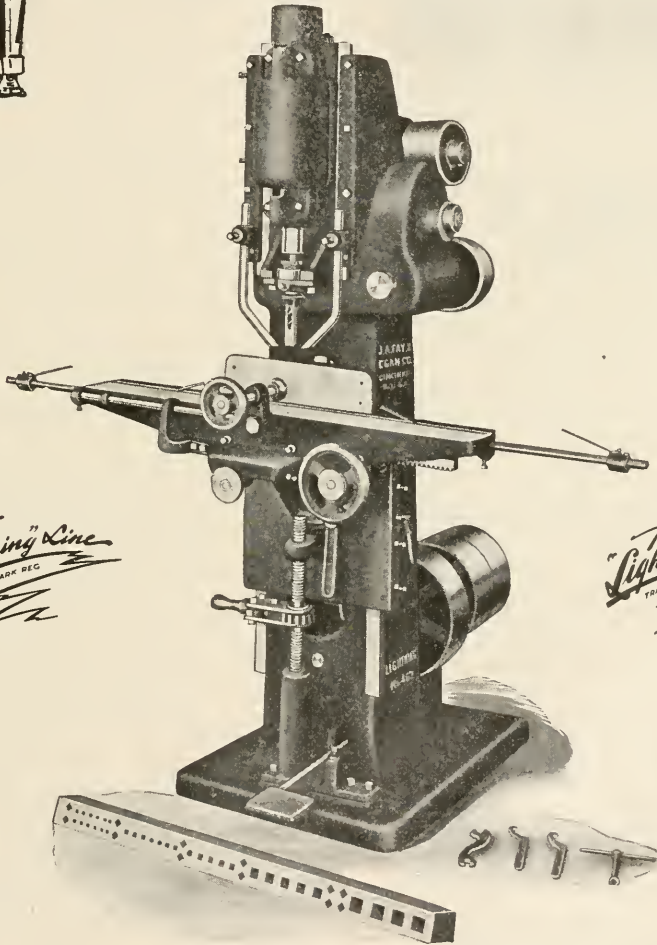

The "Lightning" Line
TRADE MARK REG.

The "Lightning" Line
TRADE MARK REG.

Automatic Vertical Hollow Chisel Mortiser

A simple and sturdy machine that will produce a good, clean and accurate mortise rapidly.

J. A. FAY & EGAN CO.

Established 1830

730-750 W. Front St.

Cincinnati, Ohio



"They're the Best rules made
-I've carried mine for many a year"

STANLEY "ZIG ZAG" RULES

A rule MUST BE STRONG, ACCURATE AND LEGIBLE. It is subjected to the hardest kind of usage and must "stand up" under the most rigorous wear and tear.

Stanley Zig Zag Rules will not wear away and loosen at the joints. The Concealed joint type has patented Strike Plates at each section—The Rivet Joint Types have a specially made rivet that acts as a Strike Plate. Made in several different styles of markings.

They are made with an especially fine and durable finish.

Among other invaluable and special features are the patented direction arrows enabling the user to tell at a glance which end of the rule to begin using. The Patented tips, joints and Strike Plates are brass plated.

Send for Catalog 15J.

THE STANLEY RULE & LEVEL PLANT.
THE STANLEY WORKS
NEW BRITAIN, CONN. U.S.A.

Branch Offices: New York, Chicago, San Francisco, Los Angeles, Seattle, Atlanta.



FIELD NOTES—(Continued)

VOCATIONAL CENTER AT NAUVOO, ILLINOIS

THE Federal Board for Vocational Education, last January, established at Nauvoo, Ill., a center for the training of the ex-soldier, sailor, or marine, who contracted tuberculosis while in service. This center is under the supervision of the Peoria Office of the Federal Board. It is ideally located and at the present time one hundred fifty inactive tubercular trainees are receiving their fundamental education under government medical supervision and Federal Board training, and pay at the rate of from \$100 a month for single men, up to \$170 a month, according to the number of dependents. An addition to the main building is under construction, and when complete will increase the unit to two hundred seventy-five. The grounds include about nineteen acres, fifteen of which are tillable. In addition to the main building, five other buildings are used for training purposes.

R. H. Harpster, an experienced educational director, is in charge of the center. The personnel includes a medical and nursing staff and fourteen teachers. The center is well equipped to lay the foundation for future institutional and industrial training. Courses are given in tailoring, horology, salesmanship and advertising, shorthand, book-keeping, typewriting, natural sciences, poultry raising, agriculture, horticulture, drafting, and practical electricity. Suitable recreation is provided in the way of concerts by orchestras and glee clubs in Nauvoo and from the surrounding towns. Weekly dances are given. One is convinced, after a visit to this Center, that the Government is striving to provide satisfactorily for the rehabilitation of the disabled ex-service man thru the agency of the Federal Board for Vocational Education.

THE ILLINOIS LEGISLATURE has passed a bill accepting the provisions of the federal law for vocational rehabilitation, and has appropriated \$125,000 to match the sum available from the federal fund in order to pursue the work of industrial rehabilitation for the coming biennium. The administration of this phase of industrial training is placed in the hands of the State Board for Vocational Education. As soon as the initial steps have been taken in the establishing of this work, the scope of the work will, no doubt, increase very rapidly.

AN UNUSUAL SUMMER SCHOOL

THE mention of a summer school calls to the mind of the average teacher hot weather, concentrated and perfunctory studies and the gen-

Manual Training Magazine

SEPTEMBER, 1921

PRACTICAL ARTS FOR VOCATIONAL GUIDANCE IN THE JUNIOR HIGH SCHOOL

JOHN M. BREWER, Harvard University

I TAKE it that students in these fields are agreed that there is really no such thing as manual training in the old formal discipline sense. Probably no one would claim that engravers or dressmakers, having well trained hands, would on that account be better marksmen or billiard players. "Training in observation," "correlation between hand and eye," discipline, accuracy, squareness of character, honesty in workmanship,—all these maxims and more of the same nature we must discard as statements of the aims of practical arts. When manual training was first begun many absurd aims were propounded which we have not outgrown. It was thought that training in one process would directly cause a gain in all other processes in which hand, eye, or mind were used, and that this gain would come automatically without any conscious striving. We know now that it is our duty to go as directly as we can to the real situation for which we wish education. All other kinds of training have about them a taint of artificiality or a training which is carried on in a rarified atmosphere, approaching in some cases to what might fairly be called training in a vacuum. Learning in a vacuum is almost as difficult as breathing in a vacuum.

No doubt any successful action which is thought to be interesting or useful will serve to awaken boys and girls and will perhaps develop that most necessary possession, the sense of success or the ideal of accomplishment. If we who are

interested in so-called manual training or the practical arts use false arguments, however, others can use them as well or better. For example, a professor of Latin not longer than three years ago told me seriously that the study of Latin is good preparation for teaching a person to drive an automobile. One who is translating a Latin sentence, he said, is required to watch the ends of a number of words at once and this ability to watch a number of changing or changeable things at the same time is exactly the thing needed in driving an automobile.

If the old exercise so long adhered to in manual training is the *vacuum*, what then is the *plenum* with which we should deal in our work in the practical arts? No doubt this ideal which should fill our practical arts workrooms in junior high school, continuation schools, and pre-vocational schools is the ideal of socially valuable work. Questions constantly before teachers and pupils should be: What practical arts does society need? What work needs to be done now? What services are required in home, farm, school, shop, street, mine, and factory? The organization of our course in the practical arts must wait upon the answers derived from study of these questions. The formalized courses in the arts are based upon unproved assumptions, these assumptions usually being that a given exercise is useful for its own sake or that an article or "method" if created will somehow, somewhere prove useful. If a

home is actually in need of a taboret or a towel roller, by all means let this particular article be made, but we should certainly suspect something wrong in the interpretation of human demand if we found all the boys and girls in a given room making the same article at the same time. It is not likely that all the mothers of all the children need taborets, towel rollers, or coat hangers simultaneously.

Shall we make a picture frame because we want to teach the bevel joint, or shall we teach the miter joint because we want to make a picture frame? Shall we put a pane of glass into a window frame because we want to teach glazing, or shall we teach glazing because we want to put glass in? Better still, no doubt, we ought to teach the miter joint because we *need* to make the picture frame, and we ought to teach it only in and thru making the needed frame, or thru making another needed article requiring such a joint.

What then about exercises? May we not lay down tentatively the following statement as a proposed axiom for the practical arts: Use exercises only when there is no other way. In cutting glass it would be too *expensive* never to teach the exercise except on an actual job. Therefore we must practice upon scraps of glass. In cutting a piece of iron with an acetylene torch, the handling of the torch for production work the first time would be too *dangerous*. We must therefore give exercises in the handling of the torch on scrap iron. In dehorning a calf "learning on the job" would be too *cruel*. We must therefore teach this skill through practice upon a detached horn. In milling a part there might be *risk of injury* to the lathe unless preliminary exercises are given. In vulcanizing, *damage* to the tire might result unless exercises upon scraps of rubber are first given.

In all of such situations, no doubt,

exercises are appropriate. In the teaching of certain other processes, situations will arise where a temporary resort to exercises, while offering no saving of danger or expense, will be of more advantage than actual productive work. But the tendency to get away from exercises in the arts unless it can be shown that such exercises have a superior value or are a real necessity, is certainly a right one.

Consider the following specifications:

PRACTICAL ARTS METHODS

1. Work resulting in a socially or commercially valuable service or article for which there is a real, previously expressed need.
2. Work resulting in a socially or commercially valuable service or article for which there is a real need not expressed.
3. Work resulting in a socially or commercially valuable service or an article for which there is no present need.
4. Work resulting in a valuable article but through a roundabout or deliberately old-fashioned process.
5. Work resulting in a valuable service or article but with an inordinate expenditure of effort or time.
6. Work resulting in an over-production or simultaneous production of useful articles.
7. Work resulting in a curiosity.
8. Work resulting in an over-production of curiosities.
9. Work resulting in an act which has no social meaning or in shaping materials into forms which are not articles at all.
10. Exercises with tools for skill in a vacuum.

No doubt the above set of specifications contains many overlapping items, but in the main it can be established beyond question of doubt, I think, that it represents a description proceeding from the desirable to the undesirable. Let the practical arts teacher, therefore, check his work by the above scale and reject No. 1 for 2, 3, or 4 only when rejection becomes necessary.

In connection with No. 4 above, a teacher once told the story of a visitor who objected to the way the pupils were working. He had remarked, said the

teacher, that clay bowls could be made by machine much faster than the students were making them by hand. The teacher's remark was, "The fool didn't realize that we weren't making clay bowls. We were making men and women." The obvious answer to such a teacher is that we ought to make men and women and clay bowls at the same time, or, better stated, make clay bowls for men and women by men and women. The deliberate choice of a roundabout method no doubt has a bad effect upon the pupils, not so much a bad effect in seeing a thing done inefficiently as the bad social effect of wasting human power. Certainly children making clay bowls should learn that some bowls can be made in a more effective social manner by machinery and others by hand.

One reason why we are concerned in improving methods of teaching practical arts is that we are extremely anxious that teachers of other subjects shall learn by a study of methods in the shop. The time will come when teachers of English will measure their work on the basis of a scale of ten points similar to the above list, and such specifications might at once be translated into terms of English composition, both oral and written, and possibly into arithmetic and geography as well.

If practical arts teachers are to make their work serve human needs, they must avoid over-attention to the by-paths such as toys, lamp shades, fancy furniture, or other inherently useful but decidedly restrictive fields of industry. I have seen at least one teacher of the arts, who, when driven into a corner with his formal discipline theories, dodged into a by-path of tin-can toys or "art products" and maintained that now at last he was fulfilling every desire of those who want productive work. Practical arts, however, if they are practical, must relate to

the daily work of mankind, and if they are arts, they must be productive. The kinds of work taught to children must relate to the kinds of work right out where workers are. Live samples of the work of the world must be provided and the samplings must be broadly selected.

One who uses the productive method in the shop must of course use a check list based on job analyses to see that all the necessary processes are learned. Teachers of printing, for example, enjoy teaching productive work, if they are not pushed too hard, and find it perfectly possible by the use of a proper check list to see that each boy or girl has an opportunity to learn each of the standard processes necessary for the trade.

We have no space to discuss the question of what a project is, but in any case our definition would be a psychological one. A project is a thing which is thought to be a project by the pupil himself. The making of a shelf at home may be the best possible project, while at the same time, the construction of a box to hold money for the school lunch room may be even more interesting. Some schools succeed in basing all their projects on school improvement; others draw heavily from the homes. A combination of both is desirable. Home economics and farm mechanics should be stressed, as they offer the best possible approach to the world of social need outside the schoolroom. The foremanship idea, the plan of participation in government, the shop committee plan, may all be used in the shop, as well as a justifiable bribery which challenges children to come and accept the advantages of diversified work on condition of good behavior, and denies them the opportunity if they refuse. Diversified work challenges industrial intelligence and leads to respect for workmen. Frequently projects are brought to school

which are entirely beyond the scope of childish effort and such a situation furnishes an opportunity for gathering about the teacher to hear of skills beyond present abilities. The sense of social contribution and individual achievement for social good is a more important product of the shop work than actual skills.

The result of work of this character is self-discovery and try-out: juvenile beginning in vocational work constitute the best manual training possible.

In concluding this phase of the study I wish to tell of two statements which illustrate the vocational guidance possible in connection with more diversified and socially-valuable practical arts.

1. The principal of a high school, speaking to a woman's club about federal aided vocational work in the school, told his hearers that now at last we were to have real standards and real work in the school. He said that we had never done genuine work in the ordinary academic studies such as English and history, and now he was going to introduce work which was to be measured by standards of work in commercial shops. After his talk I raised two or three questions with him: First, what are these standards of "real work"? Were they the standards of the average garage boy at the present time? Second, is there not much genuine production in English classes: boys and girls producing programs in oral English which are fully

as real and valuable as the work in a debating society or literary club? Third, if the vocational pupils were to have "real work," what were the other students of the school going to have who would want to take a little manual training as a part of their education? These considerations show the biased enthusiasm of the new convert to vocational education, and the need to relate the arts to the whole life of the child.

2. A state agent of Vocational Education was asked the following question: "If a boy presents himself at the vocational school and says, 'I want six months each of carpentry, machine shop, plumbing, agriculture, and printing,'—can this work receive federal aid under the rules of the Federal Board and of your state?" His answer was "No." I then asked him: "Suppose the boy comes and says he wants to be a carpenter, but at the end of six months, says that he has changed his mind and now wants to study to be a machinist. Six months after that he changes his mind again and says he now desires to become a plumber. Can Smith-Hughes money be used for his education?" Upon his answering in the affirmative, the question was then put to him, "What better kind of manual training could one have than a number of vocational courses six months to each?" Since the agent was before a public audience he did not wish to answer the question in my terms, but I believe he agreed with me.

I would much sooner surrender a portion of the territory of the commonwealth to an ambitious and aggressive neighbor than I would surrender the minds of its children to the domain of ignorance.

—HORACE MANN.

MANUAL ARTS IN THE JUNIOR HIGH SCHOOL

CHARLES A. BENNETT

MANY times during the past year I have been asked such questions as these: "What manual arts subjects are usually taught in junior high schools?" "How many hours a week are given to shopwork in a junior high school?" "Will you please send me outlines of industrial courses for a junior high school?" On several occasions I have been embarrassed because I could not answer what seemed to be reasonable questions. Later, I was asked to address a group of teachers on the manual arts in the junior high school. Then I began to collect data on the subject. What I collected is not important; it has no special value; but it does, perhaps, indicate certain present tendencies and, therefore, may be of interest to some of the readers of these pages.

I sent a letter to thirty-eight cities of the second class, thinking they would be the best index of the real condition of the manual arts in junior high schools. In this letter I asked for the names of the manual arts subjects taught, and the number of weeks and the number of hours a week each subject was taught. I received replies from twenty-eight of these cities. The replies from twenty-three gave the items I asked for; three others gave part of them.

Before presenting the summary of these replies let me recall that twenty-five years ago, before we ever heard of vocational education and vocational guidance, we were making an effort—often a fruitless effort—to get manual arts work into the seventh and eighth grades and the high school. Some cities counted themselves most progressive if they provided an hour a week of shopwork and a half hour a week for some kind of drawing in the grammar grades, and a little time for drawing and construction work in the primary grades. The most progressive

cities gave no more than from $1\frac{1}{2}$ to $2\frac{1}{2}$ hours per week to such work. It was only an occasional small suburban place that was so radical as to give a half-day—three hours to shopwork and drawing. A few did this and they have been the beacon lights to the later progress.

After the organization of the National Society for the Promotion of Industrial Education in November, 1906, and the Vocational Bureau in Boston in April, 1908, two new forces were at work to change the character of the manual arts work and to increase the amount of time given to it. The first of these forces, The Vocational Education Movement, has demanded specialization in manual arts work so that specific trades or even narrower mechanical occupations can be taught in the public schools, or in the public schools in co-operation with industry. This has required a larger amount of time for shopwork than was given to it in manual training classes. The second, the Vocational Guidance Movement, has brought a demand, not for a narrow skill-providing course, but a course made up of several acquaintance, or try-out courses to give an insight into a variety of industrial and other occupations. This demand also meant more time devoted to the manual arts.

So we have witnessed an insistent demand for more time spent on a given shop subject, and parallel with it a demand for a larger number of manual arts subjects made available to every boy in the 7th, 8th and 9th school years. And now there has come for these grades a new organization known as the junior high school, and with it a new problem for the manual arts workers.

Let us turn now to the facts gathered concerning schools that call themselves junior high schools. The number of

manual arts subjects reported are given in the following list of cities:—

Place	No. of Subjects
Chelsea, Mass.	2
Brocton, Mass.	1
Somerville, Mass.	2
New Britain, Conn.	6
Manchester, N. H.	4
Trenton, N. J.	8
Allentown, Pa.	1
Johnstown, Pa.	7
Roanoke, Va.	2
Huntington, W. Va.	3
Springfield, Ill.	3
Quincy, Ill.	4
Flint, Mich.	10
LaCrosse, Wis.	2
Duluth, Minn.	9
Sioux City, Iowa	7
Kansas City, Kan.	7
Wichita, Kan.	1
Topeka, Kan.	3
Lincoln, Nebr.	4
Houston, Texas	4
Butte, Mont.	6
Salt Lake City, Utah	4
Berkeley, Calif.	5
Pasadena, Calif.	5
Sacramento, Calif.	4
Average	4.3

The number of cities reporting each subject are indicated in the following:—

Subject	No. of Subjects
Woodworking or bench work in wood	18
Carpentry	9
Cabinet Making	9
Pattern Making (includes wood-finishing)	9
Total, Woodworking	45
Mechanical Drawing	18
Freehand Drawing	1
Total, Drawing	19
Metalwork	4
Sheet-metal work	8
Forging	3
Foundry	1
Machine Shop	1
Plumbing	2
Automobile Work	3
Repair Work and Home Mechanics	2
Mechanics	1
Total, Metalworking	25
Printing	11
Electricity	12

Brick or Cement Work	4
Reed Furniture	1
Poultry	1

The total number of subjects is 20.

In 30 cases from 7 to 10 hours a week were given to an industrial subject; in 36 cases from 4 to 6 hours; and in 29 from 1 to 3 hours.

THE TOTAL AMOUNT OF TIME GIVEN TO EACH SUBJECT IS:

	Lowest	Average	Highest	No. Re- port'g
Woodworking	42	146	400	15
Carpentry	36	182	360	7
Cabinet Making	85	206	360	9
Pattern Making	75	100	135	3
Mechanical Drawing	38	137	270	14
Freehand Drawing		120		1
Metalwork	90	152	270	3
Sheet-metal Work	30	94	180	8
Forging	75	145	270	3
Plumbing	30	52	75	2
Automobile Work	30	115	200	2
Home Mechanics		80		1
Mechanics		57		1
Printing	36	142	360	9
Electricity	14	97	270	10
Brick and Cement Work	36	82	125	4
Reed Furniture		100		1
Averages	47	118	206	

SELECTING OUT OF THE ABOVE LIST THE SUBJECTS REPORTED SEVEN OR MORE TIMES, WE HAVE:

	Lowest	Average	Highest	No. Re- port'g
Woodworking	42	146	400	15
Carpentry	36	182	360	8
Cabinet Making	85	206	360	9
Mechanical Drawing	38	137	270	14
Sheet-metal Work	30	94	180	8
Printing	36	142	360	9
Electricity	14	97	270	10
Averages	40	143	314	

An average junior high school, then, as indicated by the figures, gives manual arts instruction in between four and five subjects, and each subject is assigned 143 hours of time in the course. This is equivalent to approximately four hours a week for thirty-six weeks or $7\frac{1}{2}$ hours a week for twenty weeks.

Applying these figures to a three-year course they would mean (a) manual arts

7½ hours a week for 2½ out of the three years, or (b) manual arts subjects four hours a week for three years plus an opportunity to take an additional manual arts subject for one or two years, or (c) manual arts subjects six hours a week for three years.

I am not presenting this as the ideal amount, but as a basis for discussion. There is opportunity for some errors in the interpretation of the answers to the letters sent out. It is possible that in some of the schools offering the large number of courses several were elective, thus bringing an elective element into the results, the importance of which, in the final figure, I am unable to estimate at this time. In one case, at least, the course reported is termed the "industrial course" and it is paralleled by an "academic course" in which there is very little work in the manual arts. It seems fairly certain, however, that in many of the schools reporting, all the manual arts courses are required since they are often considered "try-out" or "trade information" courses.

Let us turn now to several of the reports which may be taken as representing different types:—

(1) Chelsea, Mass., reports one hour a week in woodworking for 120 weeks—three years, and one hour a week in printing for 80 weeks—two years. I think it is evident that in this case the organization of the junior high school has had little or no effect upon the manual arts offering, for the amount is not even a good showing for an ordinary grammar grade. One might doubt whether this school is properly named a junior high school. Notice that each of these subjects runs thru a long period—in one case three years, in the other two. This may be taken as one extreme.

(2) The other extreme, where each subject extends over a full year, is rep-

resented by Johnstown, Pa. In this school after the first year (7th grade), 36 weeks, 7½ hours per week, are given to each of seven subjects, and a student elects one of these seven each year. In the seventh year the boys are rotated in "nine-week try-outs."

In Duluth, where a similar type of course is offered, to pupils in the industrial course, ten periods a week for nine weeks are given to four subjects in the 7th grade, ten periods for eighteen weeks to two subjects in the 8th grade, and the same in the 9th grade.

It seems to be clear that in the Johnstown type of course the aim is to make the work of the last year quite definitely vocational in character for such boys as will go directly from the school to industry.

The Johnstown school seems to be the most typically vocational in character, because after the first year a boy is expected to take a subject for 36 weeks, 7½ hours per week, and, so far as stated in the report, he may elect the same subject a second year.

(3) A third type of manual arts offering is the one that consists very largely of trade information courses. The extreme reported in this direction is Kansas City, Kan., where six courses are given, each 6 weeks in length, 5 hours per week. These subjects are sheet-metal, electricity, auto mechanics, carpentry, plumbing, and poultry. The only other course mentioned is a 36 weeks, 5 hours a week, course in woodworking. These 30 hour courses would seem to be very short units for the subjects mentioned, but the purpose of this group of six courses is designated as merely "trade information." Flint, Mich., seems to offer nothing but 10 weeks courses, 7½ hours a week. Ten such courses are offered and it is proposed to add two more next year.

Trenton, N. J., offers a variety of long

period courses—40 weeks, from 2 to 6 hours a week to each (most of them 4 hours). Eight such courses are listed.

(4) The type of course that in some respects comes nearer the average of the report is represented by several Western cities. Lincoln, Nebraska, gives four subjects, 18 weeks each, $5\frac{1}{3}$ hours a week in two years. Salt Lake City gives four courses, 30 weeks each, $4\frac{1}{6}$ hours a week in three years. Butte, Mont., gives six subjects but the time is not indicated. Pasadena, Calif., gives five subjects—two of them 36 weeks, 3 hours a week, one of them 36 weeks, 10 hours a week, one 36 weeks, 5 hours a week, and one 18 weeks, 3 hours a week.

While all these cities are of the second-class, there is considerable difference in size between them and greater difference in their character and needs. Contrast, for example, Johnstown, Pa., with its industrial population with the wealthy residence city of Pasadena, California. Yet these differences do not account for the variations in the reports. There are differences in the available funds for school work, but there is a still more fundamental difference—a difference of ideals. This difference of ideals is after all the real difference in which we are especially interested. Just what should the manual arts subjects accomplish in the junior high school?

I will not attempt to answer this fully, but I will endeavor to direct your thought toward some of the vital questions involved. It is clear that we may pick out of the reports evidences of aims like the following:—

1. The manual arts work in the junior high school should aim to give knowledge and skill that will function immediately in a vocation.

2. The manual arts work in the junior high school is intended fundamentally to serve the purposes of vocational guidance.

3. The manual arts work in the junior high school is neither primarily vocational or prevocational education nor vocational guidance but is the development of the pupil in harmony with his constructive nature to become intelligent and efficient in the use of the material things of modern life in a civilized community, whatever his occupation.

In an address at the Eastern Arts Association meeting in Baltimore, Dr. David Snedden is reported to have classified the aims in education as follows:—

(a) *Developmental aims*, served by free play, stories, music, manual work of the crude manipulative expression type, and the like; (b) *Projective aims*, in the furtherance of which we introduce handwriting, spelling, silent reading, number work and so on.

Roughly speaking, we may say that *nature* demands the activities classified under (a), while *civilization* calls for the things done under (b).

In this analysis, the aims which we formulate for our work under (a) have validity if the activities actually contribute to the growth and development of the individual at the time. On the other hand, the aims set up under (b) have importance and validity only in so far as the activities engaged in look forward and function in adult life.

If this reasoning is sound, the application of this point of view takes our elementary manual training entirely out of (b), and places it in (a), and the activities are valuable and justifiable primarily for their contribution to the growth and development of boys and girls at the various stages.

After all, the place where we are going to work out the real objectives of manual training in the 12-to-15-years-of-age period will be in schools where we can have a reasonable time allowance (say, two hours daily), specially trained teachers, and special equipment.

If Dr. Snedden's contention is correct, then it is clear that we must give to the third aim, as stated above, the place of honor in our list aims for the manual arts in the junior high school.

We will then reverse the order, placing the natural development of the pupil first, vocational guidance second, and vocational or prevocational education last. If we will do this then our problem

will become less indefinite than it is today. In our search for subject-matter we shall care less for the division of industrial processes and industrial information by trades and occupations and far more for its presentation as the fundamentals of process and of fact that are behind or in our material surroundings. We will forget our divisions of subject-matter by trades, as tinsmithing, wiring, plumbing, carpentry, and find some other and more significant division. It may be that we will express these divisions in terms of tools and materials without reference to the occupations of industrial

life or, perhaps, we will find a servicable division in such large blocks of subject-matter as building, machinery, agriculture, art. There is a tendency in this direction in the new courses in household mechanics, and farm mechanics. Whether this will come or not, it is worth thinking about. If it does come, there will be some new and interesting teaching problems ahead.

If this article has not answered the questions asked at its beginning, perhaps it has asked another question that will have to be answered before a satisfactory answer to these questions is possible.

THE SELECTION OF PROJECTS FOR A MECHANIC ARTS COURSE

J. N. BAKER, Instructor of Machine Shop Practice, Germantown High School, Philadelphia

IT SHOULD be realized that in the choice of a project for the mechanic arts shop there is involved a consideration of all of the purposes of the subject we are teaching. Our project or sequence of projects should represent our body of subject matter much as a carefully selected textbook covers or best presents the subject-matter in history or arithmetic. Shop talks or notes should add to the content represented by the projects.

Before selecting projects for a course it is of prime importance that we have clearly defined aims in mind for the work; aims both remote and immediate. Too often we become so lost in the detail of the work in hand that we become educationally nearsighted—losing sight of the general objectives of our work and its relation to the other work of the school.

Aims for mechanic arts work have been variously stated. The history of the manual training movement shows that almost from the beginning it has been as highly formalized as any academic subject and its advocates have claimed "mental discipline" as its chief con-

tribution. The subject matter, instead of the boy, has received first consideration. With the development of the newer thought in education, which cast doubt upon the transfer value of training, came a more definite statement of aims which for our Philadelphia mechanic arts work have been determined by taking a composite of the best thought of those in charge of the work.

Briefly they are stated as

- (1) Bodily and mental development and co-operation
- (2) Vocational and pre-occupational contribution
- (3) Cultural contribution
- (4) Ethical contribution—development of ideals of service and citizenship
- (5) Correlation with academic classroom work
- (6) Stimulus to further education
- (7) Enrichment of vocabulary.

A very good statement of objectives for secondary mechanic arts work recently made, added to the thought expressed in these seven the following:

- (a) Development of tolerance with appreciation

(b) Producing successfully some commodity needed by society

(c) Training and developing leaders.
The majority of these would be classed

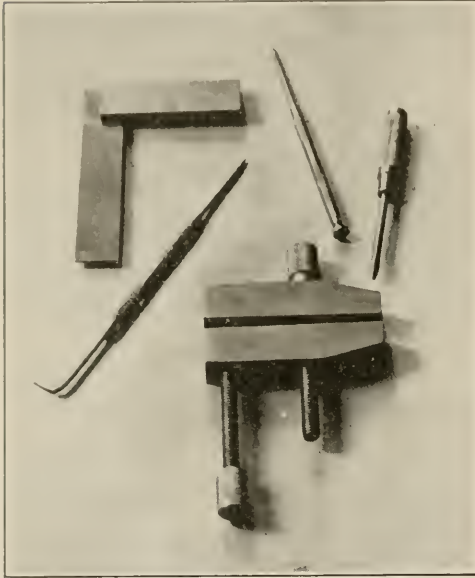

PROJECTS FROM ELEMENTARY MACHINE SHOP WORK

as remote aims to the realization of which we are only contributing our share, but, nevertheless, it is well that we take our own individual survey occasionally to see that we are doing our share.

These general objectives have a greater determining influence on *method* than on *content*,—on the manner of handling the class rather than on the project the students are making. But those aims which may be classed as immediate—e. g., an understanding of mechanical processes, knowledge of materials, successful production of useful articles—all of these have a direct bearing on the *content* of the course—the project.

I have made a partial analysis of the considerations involved in the selection of a mechanic arts project, listing a few questions we might ask ourselves concerning any project we had in mind for the course. As many of these considerations seem of equal weight, I have not

attempted a listing in the order of importance.

I. Is the project within the capacity of shop and equipment?

I have placed this first because a negative answer to this question makes further consideration of a project useless. For an occasional job we can devise means for doing something that may be too large for the shop or machine, but as a project in the course it would be out of the question.

II. Is it within the ability of the boy?

The answer to this question is of course the personal opinion of the instructor and the answer will show that these opinions are widely divergent. We find a teacher successfully producing a project in his shop while other teachers insist that the project is too "ambitious" and not within the ability of the boy. Tracing these differences of opinion further we find they frequently lead to a difference in the degree of excellence of workmanship demanded. One teacher believes the project should be extremely

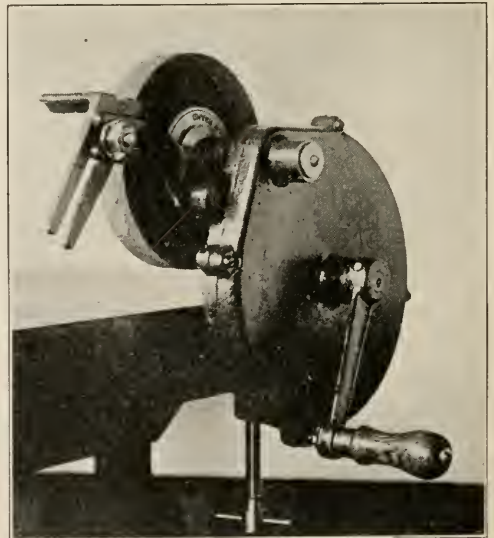

ASSEMBLED BENCH GRINDER

simple (if he uses a project at all) but the workmanship similar in perfection to

the work of a tradesman. The other—the teacher of the newer school—believes it is better to have provided larger opportunities for the boy's individual expression, for gratifying a real and not an

should be made of individual differences. Unless we are fairly sure that a project selected for a group is well within the ability of the boys of lesser aptitude, then we should arrange for more than

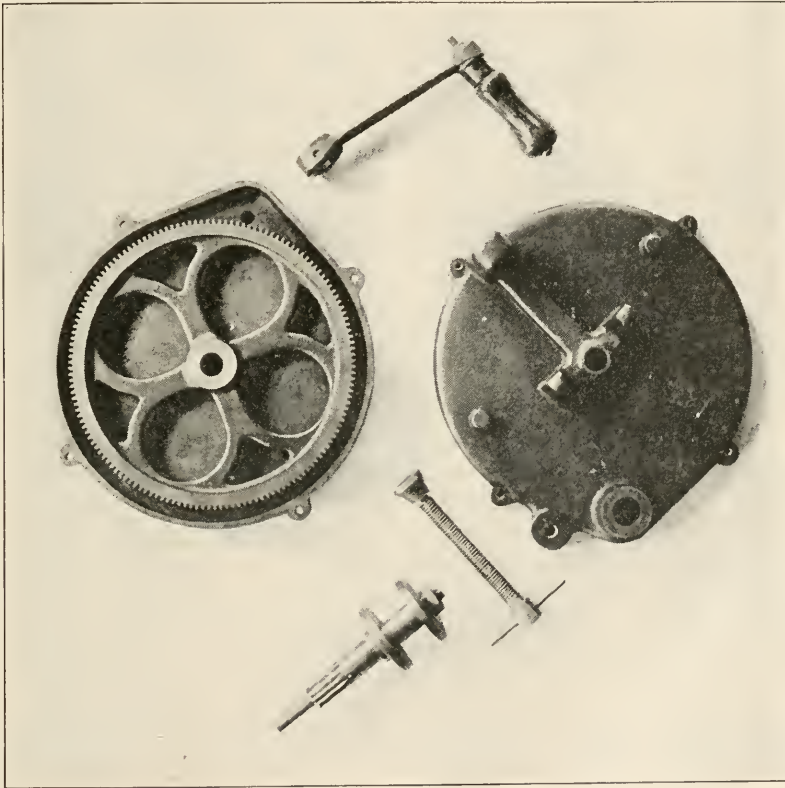

DETAILS OF BENCH GRINDER

artificial need, even tho there and here may be detected unmistakable evidences of the project having been boy's work. And even if these earmarks are not detectable it does not necessarily follow that the project is not the work of the boy—the imputation most frequently made.

Differences in method of instruction or in presenting the problem may account for results that at first glance seem impossible.

In discussing the project and its relation to the ability of the boy, mention

one project and of varying degrees of difficulty—not with the idea of passing all pupils along, with little effort on their part, but that each boy may derive the full educational value from having satisfactorily completed some project.

III. Having decided that a project is within the capacity of shop and pupil, our next consideration is—has it educational value?

After analysis does it show that it covers the desired ground established for the course or part of the course? Can it be presented in such a way as to bring

thought provoking problems to the boy? Is there in its construction too great a repetition of operations?

All of these questions aid in determining the educational value of the project and prove that merely "making something" will not always suffice for a unit of instruction.

IV. Fourth and closely associated with the third consideration—does it contribute toward the realization of our general objectives? Choose those stated aims that have a determining influence on subject matter and weigh the project carefully from that standpoint. After all, the project is only a means to an end and great care is needed to avoid making the completion of the project the ultimate rather than a proximate aim.

V. Our fifth question—has it interest value—can interest be sustained?—brings in the strongest motive force with which we have to deal in education. Generally speaking we have interest in things that are satisfying some felt need. And this brings sharply before us the issue of the "exercise" of formal training versus the project with the work motivated thru the interest the boy has in what he is making.

While we have criticized some academic teachers for their abstract method of teaching, the teachers of manual training have been even more backward in accepting the newer or psychological order in presenting their subject. Thorndike warns against

- (1) "arranging a subject for study in a way that seems most fit to one who has learned it all;
- (2) arranging a subject independently of pupils' interests and motives; and
- (3) arranging a subject as if the pupil could appreciate beforehand what the total effect of each stage's work would be, and act with perfect wisdom."

And he cites the woodworking in manual training shops as an illustration

of the errors against which he warns. Expert teachers of physics are now insisting that its instruments of precision shall be introduced by their service in getting information of value in itself at the time, not with a mere promise that by learning to make exact measurements one will sometime get significant facts.

Surely mechanic arts teachers can teach the use of trade tools as well as tools of thought and skill through a project of intrinsic value.

VI. Our sixth consideration is the artistic value of the project—a side we can little afford to neglect. A project need not of course be rejected because of inartistic lines if they admit of modification, but the result should be something satisfying to look at. In the machine shop project the artistic value is the well balanced design or the symmetry of the whole assembled project.

VII. The seventh and last question cannot always be the last one taken into account. Is the project reasonable from an economic standpoint? Does its cost of materials, etc., make it impractical?

Would the risk of spoilage be too great? Would expensive special tools be required for its construction? All these are practical questions that will go far toward the acceptance or the rejection of a project.

Summarizing, after having determined that a project is within the capacity of boy and shop, we have five values to look for in our analysis of the project—educational, objective, interest, art and economic. It is scarcely to be hoped that a project will measure up to ideal standards in all of these, but having analyzed and measured it by these standards, the teacher has reached a careful rather than a "snap" decision, and subjectively he must have profited by looking at his work in a professional way and putting to practical use the statement of aims for his mechanic arts work.

SHOP ORGANIZATION AND CARE OF SHOP EQUIPMENT

DEWITT HUNT, Director, Shop Practice, Oklahoma Agricultural and Mechanical College, Stillwater, Okla.

MUCH has been written on the subject of shop organization in general, but far less about the actual organization of the usual manual training shop. There are certain problems of caring for and using shop equipment that are common to all manual training shops, so that many definite rules and precepts may be advanced which will have general application. Many of these suggestions will apply equally well to trade school shops.

scrap stock should be discarded, but he may be required to throw all waste stock in a scrap box. The instructor should check over the stock to see that nothing usable is swept away.

The second general rule is: *Nothing should be left on the floor of the shop which is not to be swept away.* Every nook and corner of a shop should be swept every day, yet if the teacher allows stock to accumulate in corners and around ma-

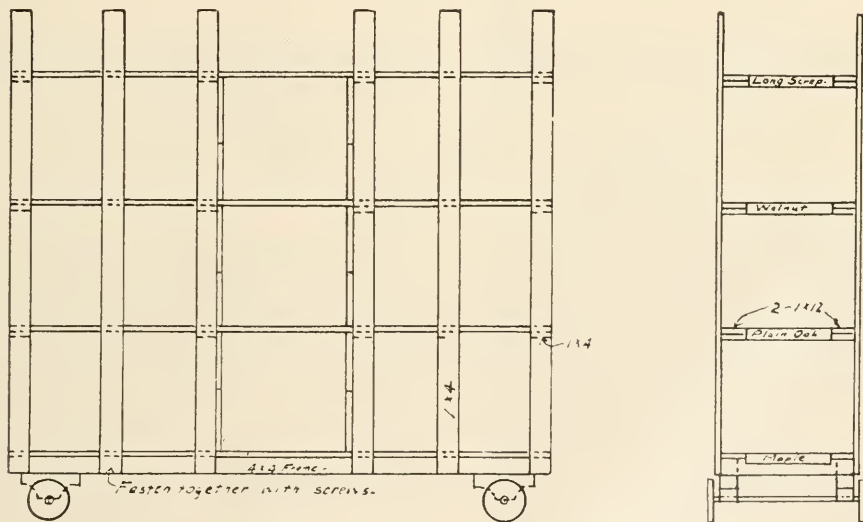

FIG. 1. SCRAP RACK SUITABLE FOR A SHOP WHERE 5 OR 6 DIFFERENT KINDS OF WOOD ARE USED

There are some general rules that may well be stated before considering specific problems. The first is: *It is as much the teacher's duty to see that the student cleans up properly as it is to see that he does good work.* The teacher who cannot get his shop cleaned up properly by the class is not entirely successful. And yet there are some things that the student should not be expected to do. One of these things is janitor work, unless the students in other classes do this work, too. The student cannot be asked to decide what

chines and benches, naturally the janitor will not move this stock to sweep. Of course, should a janitor find a tool or some part of a piece of work in the course of construction, etc., on the floor he should exercise judgment enough not to sweep out something which he knows may be of value and may have been overlooked by the instructor. But unfinished work should be kept in lockers, in racks on the walls, in a storeroom, or stacked on tables above the floor, so that this rule may be followed. A certain part of the floor of

the shop should be set aside for assembled work that will not go in lockers.

A third general rule is: *There must be a scrap rack of some nature in which to keep separated various kinds of scrap stock.* This is a problem which has few satisfactory solutions.

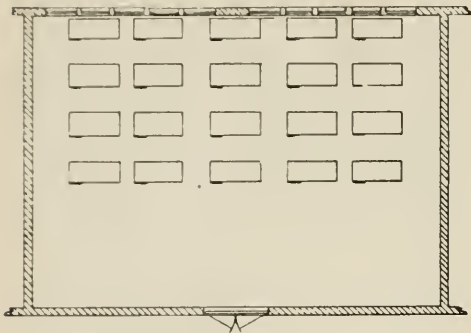

FIRST CHOICE

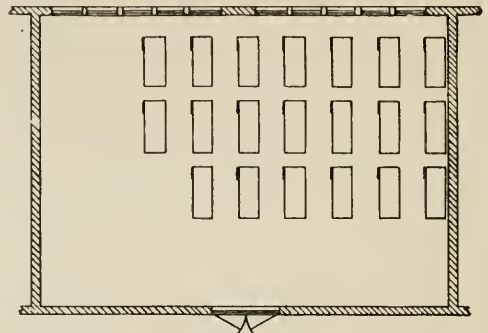

SECOND CHOICE

FIG. 2. ARRANGEMENT OF BENCHES WITH RESPECT TO LIGHT

The rack for wood scraps shown in Fig. 1 has given some satisfaction in a woodwork shop. It has nine spaces for short stock of different kinds and one for long stock of miscellaneous kinds. Two such racks are maintained in the writer's shop, and some compartments are available for stacking parts of cabinet work under construction in Smith-Hughes cabinet making classes.

The most satisfactory stock racks for machine shop and forge rooms are those where the iron stands on end and leans against a blank wall, the scrap stock being kept in the bottom of a compartment holding similar stock. Necessary care must be taken to keep stock from falling down and injuring students or instructors.

A fourth rule is: *After each class, and particularly at the end of each day's work, the instructor must put the shop in order.* The instructor who can dismiss a class at four o'clock and get away at four-five is either a marvel or a shirker. There are certain things a shop teacher must do at the end of a day's work:

(1) He must check out the class and check up tools at the desks used by individual members of the class. (This must be done at the end of every class period, perhaps the best way being for the teacher to stand at the door and check students out, particularly when tools

are in the tool rack on top of the desk and visible.)

(2) He should make a general survey of the shop, replacing tools, clamps, etc., and should check all machines to see that all removable parts, particularly live and dead centers of lathes, are in place, since these are likely to drop on the floor and be swept out by a careless janitor. All saw fixtures and parts should be located on a panel, so that at a glance the instructor may see whether each piece is available.

(3) All electric switches should be disconnected, and all steam valves turned off. Rags used in wiping off stain should be placed in metal containers. This rule is given because of the teacher's responsibility in case of fire. He should be faithful in checking these points every day; it will soon become a habit. In the case of electric glue-pots, the best policy is to disconnect the wire entirely; then the instructor has absolute assurance that it will not heat all night. The writer has no knowledge of electric glue-pots burn-

ing up school buildings but they do burn up glue and cause a frightful smell. If the teacher is negligent in taking care of rags used in wiping stains and paints they may cause spontaneous combustion. Matches must be kept out of the shop. The shops of the A. and M. College of

ever, a student failing to clean up properly should be reprimanded and should have his standing reduced.

When the instructor has done all this, straightened up his own desk and removed his overalls or apron and washed himself, what time should he have spent

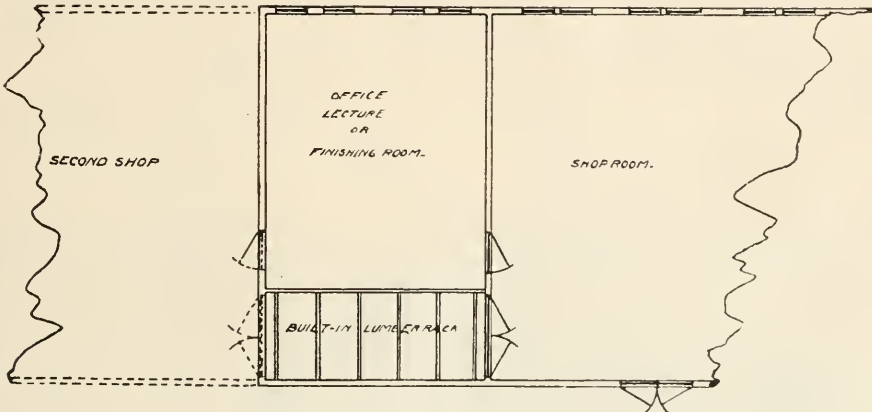

FIG. 3. IDEAL ARRANGEMENT OF LUMBER STORAGE RACK

Texas burned to the ground last fall. Many school buildings burn each year. It is the manual training teacher's duty to do what he can to reduce fire hazard.

(4) The teacher should, at the end of each day, salvage all scrap stock which is usable and throw all other on the floor for the janitor to sweep out. The salvaged stock should be sorted and put away in the scrap rack so that it will be convenient for the student to find and use. No one knows as well as the instructor what scrap is worth saving, so that it is very hard to delegate this duty to anyone else.

(5) If any machines or benches have been improperly cleaned by students, the instructor should take the name of the student, if the responsibility can be placed, and should then clean the machine or bench. This work should not be asked of the janitor, and if the instructor cannot see that it is done by the student, he should do it himself. How-

ever, a student failing to clean up properly should be reprimanded and almost impossible for the manual training teacher to coach athletics in addition to his shop duties. He will surely neglect one or the other of his jobs.

With these specific rules that will apply to any shop, we will proceed to a study of some of the common problems of the wood shop.

BENCHES

It is almost needless to say that the bench and its equipment must be kept in order. Yet many bench vises lie down and die of starvation for want of lubricating oil. It is well to have each vise oiled every two weeks by the students. Nothing will show more clearly the advantages of a lubricant. Then the bench must be fastened down. If the bench has four legs and the shop has a wood floor, angle irons on each leg and wood screws will suffice. If it is a paneled bench containing drawers, and the panels

go to the floor, a satisfactory way to fasten it to the floor, from a janitor's standpoint, is to nail a quarter-round all around it after the angle irons are used. But when the shop has a concrete floor, which it should *not* have, the bench should be fastened down by using lag screws. To hold lag screws in concrete, locate position of lag screw in floor. Then, with

front. The first part of this statement is easily proved, for no workman wants to work in his own shadow. The second may not be so evident. In drawing a line with a try-square the light would be more nearly suitable if it should come from right front but when sawing to a mark on the bench-hook it would be better if light should come from left front.

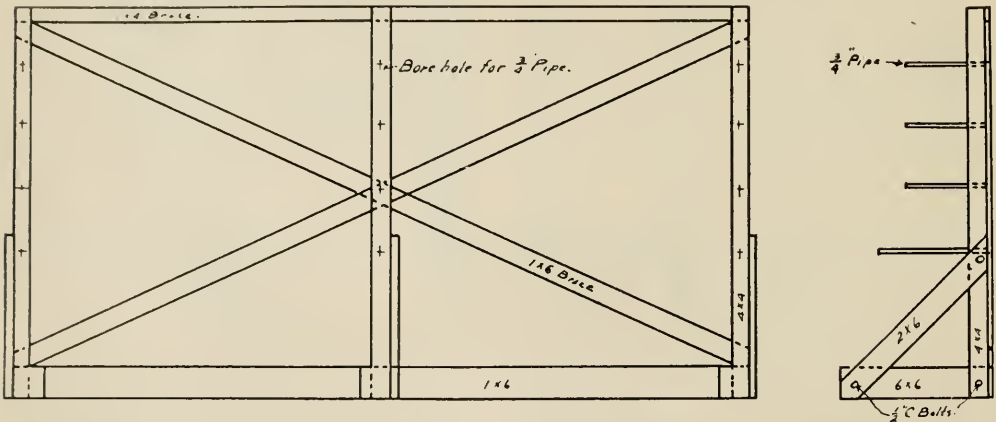

FIG. 4. MOVABLE LUMBER RACK

an ordinary $\frac{3}{4}$ " stone drill, cut a $\frac{3}{4}$ " round hole, 3" deep, by striking uniform blows on drill while revolving it. From this point three different methods are possible: (1) Use an expansion bolt of the correct size to go in hole drilled and to allow a bolt to be screwed in. (2) Drive a round oak plug of wood a little larger than hole as far as possible, saw off level with top of floor, bore correct size pilot hole and screw lag screw in. (3) Suspend lag screw in hole and pour hole full of lead. Unscrew lag screw and then place bench in position and screw lag screw back into lead.

Benches must, however, be located with proper consideration for correct lighting. When all light comes from one side of the room there are two possible arrangements, Fig. 2.

The light in benchwork *must* come from the front and preferably from the right

front. In sawing to a line when holding a piece flatwise in vise, it would be best to have light come from the right front.

LUMBER

Of all lumber rack arrangements now in use, probably the most satisfactory for the small shop is one that is built into the building. A room 6 ft. wide and 18 ft. long with a double door 8 ft. high will hold 8,000 ft. of lumber, which is more than the small shop will need on hand at any time. The shop teacher who is on the ground when a new high school is built, should try to do three things: (1) see that wood floors are provided in the woodwork room; (2) see that lumber storage is provided in the plan of the building; (3) see that the wiring of the shop is properly provided for in the plans. Fig. 3 shows a plan of a built-in lumber rack 8 ft. x 18 ft. which may be made accessible for one or two wood shops.

When the shop has no provision for lumber storage, a rack of some sort must be built. The rack which is accessible from one end only is not satisfactory for a small amount of lumber. Fig. 4 shows a rack which is easily made and of the greatest convenience.

This rack is substantial and will hold about 600 feet of lumber. A 1 x 6 may

be nailed on front of 6 x 6 base blocks and the space enclosed used for scrap stock. Manual training teachers are often guilty of mutilating walls of school rooms assigned to them for shop rooms. The lumber rack which necessitates nailing or fastening to the wall should not be allowed by the superintendent.

(To be continued)



AT THE MOTOR TRANSPORT TRAINING SCHOOL, CAMP HOLABIRD, BALTIMORE, MARYLAND.
COL. GEORGE P. HARVES, JR., COMMANDANT



EDITORIAL REVIEW FOR THE MONTH

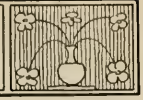

AMERICANIZATION

THERE are two outstanding viewpoints in reference to Americanization: (a) that of the publicist who deals with facts, figures, tendencies, racial and national effects, and means, both preventive and remedial; and (b) that of the socially-minded citizen who sees in the immigrant an opportunity to render service to a brother and to the nation he loves. The publicist, as a rule, would make immigration difficult or impossible; he stands for what he regards an American standard of living and thinking. The socially-minded citizen substitutes kind acts for cold theory; he tries to make the best of the situation as he finds it and holds fast to his faith in the regenerating power of the spirit of America.

The publicist assumes a critical attitude. He says that we are a nation of confirmed uplifters; that we are never quite happy except when we are reforming somebody. He sometimes suggests that we are more interested in the process of reforming than in the human being reformed, that, as in money-getting, it is the game that allures us on. Yet the publicist usually tells you that he believes in Americanization minus sentimentalism and minus patronizing and plus good sense. Fundamentally, the Americanization idea is all right, he says, but, (a) Superior persons must not set out to improve inferior ones. This is resented by immigrants, and rightly so. (b) We must not get the idea that the only persons needing to be Americanized are foreigners. The home-grown variety needing Americanizing is often just as numerous and more in evidence. (c) There is danger that the program of Americanization may be reduced to such formulae as "Learn the

English language," "Respect the government," "Take out citizenship papers."

A few weeks ago the editor of *The Saturday Evening Post* said,

For some years past we have not been Americanizing a large part of our immigrants; they have been Europeanizing us. We have been teutonized, Slav-icized, Orientalized, mongrelized, terrorized and sentimentalized. And we have been getting the poorest and not the best even of these races that we find it hardest to assimilate, admirable tho many of these races are when they are living in their own environment and developing under their own institutions.

.....In spite of the evidence on every side, sentimentalists still picture Uncle Sam as a clever chef who can take a handful of foreign scraps, a sprig of Americanism, and a clove of democracy, and skillfully blend the mess into something fine and desirable. Superficially, of course, America is doing much for the latter-day immigrants, but it is not making the major part of them into Americans. A change of air, of scene and of job cannot change the fundamental facts of heredity, and it is on these that a race is built. Race character is as fixed a fact as race color, and it is modified and changed only thru slow generations.....

Americans were not fused into one breed in the melting pot, in the factories and the slums. They were one, tho from many countries, made one people by their viking adventuring across the seas and their long fight together in the wilderness. They were bound into brotherhood by their common aspiration for a home, a church, and a government that would express their right to have and to hold what they made by their labor; to worship as they pleased; and to govern themselves as a sovereign people. Neither the divine right of kings nor the divine right of the proletariat came over with the old stock. The same kind of brains that once held the first idea now proclaims the second. The trouble with our Americanization program is that a large part of our recent immigrants can never become Americans. They will always be American-ski—near Americans with un-American ideas and ideals.

Turning from the viewpoint of the publicist to that of the socially-minded citizen who has had experience with foreigners we find conclusions that are es-

sentially the same. Our citizen has been developing what he considers the essentials of a program of Americanization: (1) teaching English, (2) naturalization, (3) lectures and entertainments, (4) recreational activities, (5) advisory councils. These seem to him to be necessary, yet somehow they do not of themselves get to the heart of the matter. All these may be done in a formal way without producing Americans. As Mr. Brooks says in his book, "Christian Americanization," one does not automatically become an American by becoming naturalized, learning the language, wearing American-made clothes or by imitating American fashions and customs. *Americanization is a spiritual process*—often slow, indirect, unconscious. Another writer, Carol Aronovici, has said that "understanding, tolerance, service are the chief needs of the immigrant in process of Americanization." Beyond these efforts the Americanization movement applies to all the people of America and comprises all education, all efforts toward social justice, all striving toward national unity and national development.

It would be a good thing for the nation to have every citizen, and especially every teacher, realize that neither legislation nor teaching a course or two in the English language is alone going to make Americans out of Europeans. Social changes such as are desired come slowly thru common experiences. They do not come so much thru institutions and organizations as thru the normal, unconscious and direct influences which emanate from home and school and "radiate from dynamic personalities." The school should keep this fact in mind and should see to it that the subtler forces for Americanization and not merely the formal program of studies are kept active. Fortunate in the school whose teaching staff is made up of men and women with "dynamic

personalities" who have sound ideas on Americanization.

ILLINOIS DROPS BEHIND

TWO years ago the friends of industrial education in Illinois were rejoicing because a compulsory continuation school law had been written on the statute books. Now these same friends are baffled because the State Legislature has stricken out the compulsory clause before the time appointed for it to go into effect. When they ask for the reason the answers seem unworthy of the great State of Illinois.

The most common reason given is "lack of school funds," yet there are funds for less important purposes (not to mention anything worse). If the legislators had read some of the testimonies of school superintendents in the state who have been in charge of continuation schools during the past year, if they could have recognized the value of such educational reclamation work as has already been begun in several cities—if they are really interested in the welfare of the future citizens of the state, it would seem that they could have found some way to solve the financial problem.

Two years ago, labor leaders, manufacturers, social workers and many educators joined hands in asking for the compulsory law. This year, labor leaders and manufacturers seemed to be indifferent, or unaware of what was taking place at Springfield, and the school superintendents in some sections of the state, at least, favored the change in the law because it made their problems easier during the coming year.

After such a general slump of interest and ideals, or shall we say, after this display of fear and precaution, the chief source of hope seems to be in the further development of the voluntary continuation schools already established until a

later Legislature will see that all children have a fair chance regardless of their economic condition.

THE NEW PRESIDENT OF THE WESTERN ARTS ASSOCIATION

THE method of selecting officers in the Western Arts Association is to elect in the most democratic fashion a nominating committee, whose business it is to search out the best persons for officers. The only restrictions placed on this committee is one of custom—to alternate presidents between men and women, or, what usually amounts to the same thing, between art teachers and manual training or vocational teachers. When the nominating committee made its announcement this year at the meeting in Peoria there was a very general expression of satisfaction. In fact, it was more than satisfaction; it amounted to enthusiasm. There was a feeling on the part of everyone that Carl T. Cotter of Toledo was just the man to give the Association a progressive administration, and that under his leadership the meeting next spring in Cincinnati would touch another highwater mark in the history of this pioneer and influential organization. His record of fifteen years in the Association, his service for three terms on the Editorial Board, his personal popularity and business-like way of doing things all seemed to spell success for the year's work.

Besides his Association record Mr. Cotter has a consistent one as a teacher and supervisor. After graduating from the Engineering Department of the University of Michigan he had two years of shop and factory experience and then taught mechanical drawing at the Scott Manual Training School of Toledo University. He taught for two years at the Hackley Manual Training School in Muskegon, Mich., and the next two years he was director of the school. From this position he was taken back to Toledo in 1909

as director of manual training in the public school system. In this position he has done an important work for Toledo.

There is no doubt that Mr. Cotter realizes his responsibility to the Association in accepting the office of president. If the members of the Association—and especially the men—will only realize their equal responsibility to the Association and to its president, and support him in



CARL T. COTTER

every move, the Association will go rapidly forward during the year. We believe this is just what will come to pass.

USE OF INDUSTRIAL FILMS

THE progress of the industrial film as an educational means is suggested by information received from the Western Electric Co.

A list of 14 titles of films recently received from the New York City office, 110 William St., is most alluring. The first four have to do with pole-making in the forests of the Northwest and would seem to be thoroly entertaining as well as instructive. In fact, this seems to be a characteristic of the entire list.

These films are loaned for educational purposes upon most reasonable conditions—guarantee against damage, prepayment of transportation, and reporting the number and sizes of audiences.

A POINT OF VIEW

BY THIS TIME the word "Hawkins has resigned" has spread over the country. Layton S. Hawkins, chief of the Vocational Education Division of the Federal Board for Vocational Education was Prosser's right-hand man in the early days of the Board's organization. He was all of that and more too if such were possible. Since Prosser's resignation he has been the sheet anchor of safety, the hitching post for ideas, and a wire fence to catch the wild balls of the vocational education movement.

In the early beginnings Prosser had a good team; basemen, pitcher, catcher, and outfielders were trained people, and the batting average was high. More than one home run was scored. Many state programs are a credit to the movement. A few would be a disgrace had they been allowed to pass the censor. The Washington force and its regional directors, reinforced by Munroe, Greathouse, and Holder, paid members of the Board, made a real team. The outfielders, such as Johnson, Dimmitt, Wright, Smiths (K. G. and H. B.), Lane, Heim, Hummel, Linke, Sargent, Cramer, Williams, Taylor, Richardson, and Loomis, were great representatives of the Washington force, Munroe, Holder, and Greathouse, each in his way, were forces for furthering a great movement; one a writer and thinker, educator, and man of affairs, one a fine spirited democrat who knew the feel of a working man's pulse, one a former state superintendent of schools with rural affections and political insight.

These were halcyon days. And then the disorganization began. The outfielders were called in to catch and throw balls in and around the diamond. Prosser went back to Minneapolis. The rehabilitation work had so grown (in public discussion and criticism, at least) that it,

originally a tail to the dog, so wagged the dog that Congress, the press, the ex-service men and the people forgot all about poor doggy and began hacking its tail, inserting new sections, squeezing it, kicking it, until the country as a whole had the idea that the Federal Board for Vocational Education was a rehabilitation board and nothing more.

Then Lamkin became Director. Quite irrespective of his fine qualities, personal and professional, this appointment ignored not only the value of the services of Hawkins, but which was more important, it relegated to the rear the vocational education work of the Federal Board. It made the man in charge of the dog's tail the one who held the leash of the dog. Doggy, however, was so small that he looked like a new kind of a four-legged head to a huge worm. Lamkin's salary was made far less than Prosser's. Hawkins more than ever had to keep the little dog alive. The outfielders had left the Board (to live in Washington on \$3,500 is not a picnic). There was a delay in getting new men to fill their places. The States were calling for the dog but he had so much tail that he could not get away easily or travel far.

I have no criticism of Lamkin. I am told by all that he is a fine fellow, but (and there is a "but") I shall always feel (and I voice the spoken and silent word of many of the fellows) that Hawkins should have been made director. But it does not make any difference now,—that is, to him or to me (it does to the country at large, tho). He has gone to a much more lucrative position of great responsibility and wonderful opportunities, where there are no Senate committees, travel vouchers, red tape, picayune practices, and dead levelings.

Fifteen years ago Hawkins discovered

himself in a New York normal school. He was a teacher of nature study and science. He did not purchase dried crayfish and lobsters from a school supply house for his classes in biology. He found bugs and life in the farmer's fields. He had very little sawdust-box window-sill agriculture. When I was State Director I heard of him. I looked up his record. He had the unusual combination of classical and vocational training of collegiate grade. He had John Tyler and Charles Garmon of Amherst, Liberty Hyde Bailey and Wilfred Rowley of Cornell, as teachers. He knew the farmers, school men and young people. He was an influence in his normal school community. His pet name was "Hungry." I never knew why. Those who know him now (and who does not) call him affectionately "Bill." He may have been hungry for food but I rather guess that he was hungry for ideas.

Anyhow I picked him for my agricultural specialist. That is all I did for him. He has done the rest.

Stimson of Massachusetts had already developed the home-project-in-agriculture idea. Hawkins and Dennis with rare administrative skill put it on the map in New York and Pennsylvania. He succeeded me when I left the State Department. He soon went to Washington to work along side of Prosser (Prosser is wise enough to have men along side of him instead of under him). Now he has left Washington to serve the United Typothetae of America as Educational Director of the printing schools and courses established under the direction of and at the instigation of this well-known group of employers which represents about ninety per cent of the printing industry of the United States and Canada. His new salary is not public property and the proposed organization of his work is not for me to describe.

Our interest is in him and in the significance of his new position. It is of these I would write. For sometime the feeling has been growing on me that our public vocational training is very academic. By this I mean that we are involved and perhaps necessarily so with such questions as its relation to general education, amount of cultural studies, extent of productive work, vocational guidance before choice, who will teach the related work, relation to prevocational training, etc., etc. Personally I make my living thru and in such discussions. Meanwhile the real job of training workers instead of convincing regular schoolmen of the value of vocational training still exists.

Wright had much to do with the splendid report on the paper industry. Hawkins delved successfully into the training question surrounding the hotel business. Miles has made studies on the vestibule school. Dimmitt showed the possibilities of education for textile workers. Smith studied the clay industries. Cushman the sheet-metal industries. Klinefelter the watch-making industry. Now, who or what will put some of these fine surveys across? Will schoolmen and school boards ever really tackle the real job of real vocational training? Or, will it be necessary to have employers associations, the crafts themselves, turn the trick? You and I know the place for printing in the elementary school as a part of the industrial arts movement developed on the educational basis as proposed by Bowman, Carman, and Edgerton. We know the place printing can hold as a trying-out field in the junior high school. We know what a fine thing, educationally and socially, a printing plant is in a high school scheme as developed by Mathewson. But these fine ideals and results do not make printers nor do they educate those already

printers. New types, new inks, new processes, new presses, standardization of estimating and cost accounting, will never come out of this public school education. Most of it is not trade training nor trade extension work. Of course it is educational, socially serviceable, vocationally useful in a way and not by any means to be cast aside.

There is a real job in America open to some folks to train young people and adults for the trades and industries or occupations of printing, paper, textile, clay, mining, concrete, railroads, banking, accounting, cattle raising, etc.

Hawkins has inherited the good work already done by the United Typothetae. He will further develop it. We of this magazine extend to him the best of good wishes. He is at one end of the vocational training game, we are at the other. Some day our separate work will meet and each will have defined its limitations and each will eventually meet in that middle field of co-operation.

The Federal Board has lost James P. Munroe; it has lost Hawkins, Lamkin, Fisher, Hamilton, and by the time this publication reaches you it may have lost itself. In other words, the dog may be running around without any tail with an acting director of one of the Board members working on a salary one-half of that paid Prosser. The tail may by this time have been swallowed by the

Veterans Bureau which includes rehabilitation, war risk insurance, and medical service for disabled ex-service men.

If these things happen,¹ and I suspect they will, you and I have a job. It is up to us to hold up the hands of the departed spirits, to re-read the Smith-Hughes law, to study the wise decisions made by Hawkins, to get the work of the whole country on the same fine basis now possessed by Massachusetts, California, Indiana, New Jersey, New York, Pennsylvania, and Wisconsin (the reader may add others but do not add those who want the vocational aid and not the vocational policy). The story will go out that the Federal Board has "gone broke," is "lost, strayed, or stolen," or is "on the skids." Whatever may be the situation in Washington remember that Small, Blackwell, Snyder, Callahan, Wilson, O'Leary, Trinder, French, Wreidt, Williams, Heim, Phillips, Hobdy, Browne, and a host of others still live. States still exist. The Smith-Hughes law is unrepealed and the need of holding up the hands of good men and women with back-bones instead of wish-bones is greater than ever.

—ARTHUR DEAN.

¹ Later: The conference committee fortunately refused to accept the Senate amendment to the Sweet Bill, and consequently the vocational education work of the nation is not made a part of the work of the Veteran's Bureau.

*"We all are blind until we see
That, in the human plan,
Nothing is worth making, if
It does not make the man.
Why build these cities glorious
If man unbuilded goes?
In vain we build the world, unless
The builder also grows."*

WASHINGTON CORRESPONDENCE

A LEGISLATIVE TANGLE

THOSE who are interested in legislation for vocational education and for the relief of ex-service men have had some difficulty in understanding the meaning of all the moves that have been made recently. The Sweet Bill (H: R. 6611), relating to the care and treatment of ex-service men, as it passed the House, provided for consolidating in a single Veterans Service Bureau, in the Treasury Department, all the offices charged with this work, which have been functioning separately hitherto. While specifically transferring the Rehabilitation Division from the Federal Board for Vocational Education to the new Bureau, the bill did not seem to be entirely clear as to the status of the functions and activities remaining to the Federal Board.

When the Senate took the bill under consideration it was decided to clear up any possible ambiguity, and, following the recommendations of the committee to which the bill had been referred, the Senate passed the bill with an amendment abolishing the Federal Board, and transferring all of its functions, duties, equipment, and personnel to the new bureau. The Senate amended the bill further by providing that the new bureau shall be independent of other establishments, its chief reporting directly to the President.

Various persons and agencies interested in the promotion of vocational education, foreseeing the confusion inevitably attendant upon the transfer of the Smith-Hughes work from the Federal Board to the Veterans Service Bureau, immediately set to work to persuade the conference committee of the wisdom of some other arrangement.

On Saturday, July 30, the conference committee issued a statement to the effect that agreement on the main points at issue had been reached, the Senate conferees

receding from the proposal to abolish the Federal Board, and the House conferees receding from the proposal to place the bureau in the Treasury Department. The Federal Board will thus continue the



LAYTON S. HAWKINS

functions of administering the Smith-Hughes vocational education law and the Smith-Sears law relating to rehabilitation of persons disabled in industry. The Veterans Service Bureau, an independent agency, will combine the activities hitherto carried on by the rehabilitation division of the Federal Board, the Bureau of War Risk Insurance, and the Surgeon-General's office.

On Monday, August 1, the Senate passed the bill, with amendments as agreed to by the conference committee, and it passed the House the following day.

CHANGES IN FEDERAL BOARD PERSONNEL

A NUMBER of important changes have taken place recently in the personnel of the Federal Board for Vocational Education. To what extent these

changes are due to uncertainty as to the outcome of policies now in process of formulation affecting the functions and plan of organization of the executive departments may be a matter of conjecture. With respect to the resignation of Mr. Lamkin, reported in another department last month, Mr. Munroe in an official statement attributed it in part to this uncertainty and to the Board's inability to make any promises as to the permanency of the work and the position.

Undoubtedly other considerations enter in, but it is sufficient for me at this time to record the changes. First, perhaps, I should say that Mr. Munroe's term of office expired July 17th, and thus far no announcement has been made of the appointment of a successor. James P. Munroe has been a member of the Board from the beginning, representing the manufacturing interests, and has served as vice-chairman. He is known to every reader of this *Magazine* as president of the Munroe Felt and Paper Company, Boston, Mass., as a member of the board of directors and former president of the National Society for Vocational Education, and as a prominent alumnus and trustee of Massachusetts Institute of Technology.

MR. HAWKINS GOES TO THE U. T. A.

LAYTON S. HAWKINS has resigned as assistant director for vocational education, to accept the newly created position of director of education of the United Typothetae of America, with offices in Chicago. This is the national organization of employing printers, having a membership representing approximately 80 per cent of the output produced by the printing industry in the United States. It has been doing things on a big scale for some years. Its present the annual budget for the activities of the organization aggregates something in ex-

cess of \$3,000,000, of which about \$250,000 is devoted to educational activities.

These educational activities include: correspondence study courses in cost finding, estimating, salesmanship, accounting; courses for apprentices and skilled workmen; the operation of the U. T. A. School of Printing, at Indianapolis; and supervisory relations with the school of printing in connection with Carnegie Institute of Technology, Pittsburgh, and the Harvard University graduate school of Business administration, Cambridge. These activities are to be expanded, and new lines are to be developed, including courses for the training of shop foreman, office executives, and teachers of printing.



JAMES P. MONROE

It is to co-ordinate and direct these varied activities, and to develop an organized educational program for the printing industry, that Mr. Hawkins has been called. It is a splendid opportunity, and the Typothetae are to be congratulated on the choice they have made. "Bill" Hawkins, as he is familiarly known to his associates in the Federal Board, will make the most of it.

After a year of study at the State normal school, Cortland, N. Y., he took the A. B. and A. M. degrees at Amherst Col-

lege, and some additional post-graduate work at Cornell University. After serving four years as head of the department of science and agriculture at the Cortland normal school, teaching during the summers at Cornell, he was appointed, in 1910, specialist in agricultural education in the New York State Department of Education, becoming director of vocational education in 1916 when Dr. Dean resigned to go to Teachers College. Since 1917 he has been connected with the Federal Board.

Ralph T. Fisher, who has been assistant director for vocational rehabilitation since Mr. Lamkin was made director, has resigned, to go to California. He has been appointed by Governor Stephens to a newly created position as supervisor of the State system of charitable and correctional institutions, with offices in Sacramento.

Walter I. Hamilton, who has been in charge of the Philadelphia office of the Rehabilitation Division, has resigned. When I saw him yesterday he was not at liberty to permit me to announce what his new work is to be, as he had agreed that the public statement should come first from his employers.

Charles R. Allen, who has been in charge of a school for training shop foremen, organized thru the cooperation of several large manufacturing plants in Niagara Falls, N. Y., returned to his former position with the Federal Board on June 1. For six weeks during July and August he has been in charge of a special summer institute of foreman training, conducted under the auspices of the Federal Board at Dunwoody Institute, Minneapolis, Minn.

—WILLIAM T. BAWDEN.

IN FOREIGN COUNTRIES

THE DISCOVERY OF APTITUDE A FIRST STEP IN EDUCATION

THE medical correspondent of the *London Times Educational Supplement* discusses the effect of teaching on the human brain in the following manner:

At a moment when ideas about the mechanism and working of the brain are being revised and rewritten interest attaches to the views expressed recently by Sir Arbuthnot Lane on the effects of education on this organ. Sir Arbuthnot is a surgeon with a very distinguished reputation. He belongs to that small band of scientific men which is characterized by its possession and exercise of imagination.

Speaking as a surgeon, he sees in any educational system the opening up of a pathway in the brain—that is to say a mechanical effect. The cells of the brain, he conceives, arrange themselves in a sequence determined by the nature of the calls made on their activity. It is thus possible to present a debit as well as a credit side of every transaction. The price of special knowledge is an increased degree of general ignorance. If this be granted—and Sir Arbuthnot presses the analogy of the alterations effected in the skeleton by various kinds of manual labor—then the discovery of aptitude is the neces-

sary first step in any education. Aptitude, too, acquires a new meaning. It is not so much a circumscribed gift as a general direction or bent, a tendency which, if developed, will produce the highest degree of special efficiency at the least cost of general intelligence.

In other words, there is an educational "line of least resistance" in respect of each individual. To follow that line is to avoid arousing a war within the members. Harmony, balance, perspective, are the rewards which may be expected if a correct estimate of character and capacity determines educational direction. If, on the contrary, a purely arbitrary decision is arrived at the results cannot be guaranteed. We may well, by our efforts, add to the number of gross failures and intellectual misfits. The successes achieved will scarcely justify so extravagant a waste of material. Sir Arbuthnot remarks how rarely an eminent classic succeeds in any scientific pursuit. If it is the case that the connections and inter-relationships which the cells of the brain form in response to the very arduous pursuit of classical studies unfit the owner to employ his brain in the study of scientific objects, are we wise in imparting to children more than a minimum of classical knowledge?

From this view arises a new attitude to what

teachers of the old school characterized as inattention. Inattention and its fellow, forgetfulness, are seen not as faults but as measures of self-protection against a real and imminent danger. The former represents prevention, the latter cure. For if the pupil can shut his ears and eyes he may escape the instruction which threatens to unhinge his mental habit; if he cannot shut them, he can at least ignore and so perhaps get rid of the intruder.

"Most of what one, fortunately, only too readily forgets may (Sir Arbuthnot insists) not only be not beneficial, but may be seriously detrimental to the usefulness and efficiency of the individual."

There was a period when children were forced to eat foods which nauseated them on the mistaken idea that moral principles may be assimilated from the stomach. We have discarded that physiological doctrine; but many of us cling to its psychological counterpart—that a moral value attaches to instruction the content of which is indigestible. The views of this great surgeon should help us to correct an attitude which is out of harmony with ascertained fact.

THE ONENESS OF EDUCATION

THE leading address at the Easter Conference at Loughborough College was made by Lord Burnham. This address is printed in full in *Manual Training* and extracts from it have appeared in the leading daily papers. The following is quoted from it:—

I always believe that the division of education into separate compartments must be, if it is carried to its logical conclusions, wrong and even unscientific. (Loud applause.) I take it we all here believe in the oneness of education, and I think education has suffered a great deal from a false antithesis and an artificial antagonism. To my mind it sounds absurd to divide education into cultural and technical, practical and theoretical, literary and scientific. To use a long word, and one which expresses what in my mind it seems to be intellectual particularism run mad. The truth is that men and women must not be regarded either as standardised parts of a machine nor as mere pages of a dictionary. (Applause.) Education to come up to any of the ideals of the great thinkers of the past must be treated as an integral whole in which all the various parts should be coordinated for a common end. I sometimes wonder whether we who are concerned in our daily lives, or who have any accidental connection like myself

with the educational system of the country, realize what a great debt of gratitude we owe to a man who was not only a brilliant and prolific writer, but was also an inspired prophet of the arts and crafts, I mean John Ruskin. (Applause.) You recollect that in season and out of season he was always preaching the doctrine of the unity of knowledge and the necessity of connecting manual teaching and mental training if you were to be the complete man. Some sixty or seventy years ago, I admit with a great deal of fantastic posturing, he created what was known as the St. George's Guild, at Oxford, whilst he was Slade professor of art there. The principle of St. George's Guild is the principle which lies at the bottom of all the modern developments of education today. The all round training, the dignity of manual work and the one-eyed character of mere bookish teaching,—all these proceed from the same ideas and embody the same formula. (Hear, hear.)

CERTIFICATION OF HANDICRAFT TEACHERS

THE new qualifications for handicraft teachers in England announced last September have caused so much protest and the loss of so many teachers from the profession that the question has been given further consideration by the Board of Education and the date for applying the new regulations set forward from Jan. 1, 1921 to August 1, 1924. This will give the needed time for readjustment in bringing about the higher standard. It will allow those teachers who commenced training and those who had partially qualified under the old regulations a liberal amount of time in which to come up to the requirements for the full diploma in handicraft.

J. H. JUDD of Manchester has become the secretary pro tem of the National Association of Manual Training Teachers. He has taken over the secretarial duties at the request of the Executive Council, owing to the resignation of Mr. Lineham, who has accepted a new position on the staff of the Springfield Training College.



PROJECTS, PROBLEMS AND NOTES

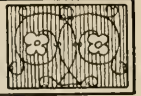

ELEMENTARY WOODWORKING PROBLEMS FROM ST. LOUIS

AT THE opening of the school year we are glad to be able to present to our shop-teacher friends a collection of drawings from St. Louis. These give problems used in the grammar grade shops last year. They do not include all that were used, but they do cover the beginning groups pretty well. In a later issue we will give some of the more advanced problems.

In conversation with Supervisor R. A. Kissack concerning these problems we learned a few of the factors entering into the selection of problems. He was free to admit that some of them were economic and not pedagogic. For instance, he pointed out the extremely difficult problem that has arisen on account of the great increase in the price of lumber. He has been paying 28 cents a foot for lumber that formerly was 4 cents or 5 cents a foot, and his appropriation for lumber has not increased to match this difference in price. The problems selected have, therefore, been such as required a relatively small amount of lumber and lent themselves very well to the use of scraps of lumber and old boxes that could be picked up by the boys. He said that 6,000 boys in St. Louis had been scouting for lumber fit to use in the manual training shops.

Mr. Kissack recognizes that such conditions are not normal and are far from ideal, but to a greater or lesser extent, they exist in other cities. For that reason the St. Louis solution of the problem is interesting to readers of this Magazine.

Another characteristic of the problems, and this has been recognized as distinguishing the work in St. Louis for several years, is the attention given to designing.

It is specifically designated that the problems in Groups E and H, for example, shall be design problems.

Not all the problems of any group are given in the drawings, but the ones given are fairly typical of the groups they represent.

They are arranged thus:

SEVENTH GRADE

- Group A. Bread board.
- Group B. Match striker, calender stand, match-box holder, game board, spool holder, clothes stick.
- Group C. Tea-pot stand, tooth-brush holder.
- Group D. Collar and tie rack, cake board.
- Group E. (Design) Stationery holder.

EIGHTH GRADE

- Group H. (Design) Book-rack ends, letter-box, folding checker board.
- Group I. Nut bowl.
- Group J. Snow shovel, rake, lawn chair.
- Group K. Handkerchief box.

A STEEL HARDENING TESTER MAGNET

THE tool illustrated herewith should be in every school forge shop and is an interesting and profitable project for a class. The tool steel part may be $\frac{3}{16}$ " x $1\frac{1}{4}$ " x 6", and of the form shown in the sketch or merely the outline of a banana. An old file, with serrations ground off, or the shank of a worn out lathe tool, drawn out, may be used. After being formed to the desired shape, the piece should be annealed, filed and polished. The hole should be carefully laid out and drilled; then the piece balanced about the hole and afterwards hardened. It is then ready to be magnetized.

To magnetize the piece of hardened steel, wind about one hundred turns of No. 18 B. & S. gage copper wire around a paste-board tube, about $1\frac{1}{2}$ " in diameter. Use 110 volt D. C. current, if available, and for a rheostat use a lamp bank having six or eight lamps connected in parallel. Join the lamp bank in series with the winding on the tube and connect thru a double-pole switch to the 110 D. C. supply. Place the piece of steel inside the tube and allow the current to flow thru the coil for about one half hour. Use from five to eight lamps as necessary to avoid the overheating of the wire. In case the 110 volt D. C. current is not available, about 25 feet of No. 14 wire may be wound on the

CALANDER STAND

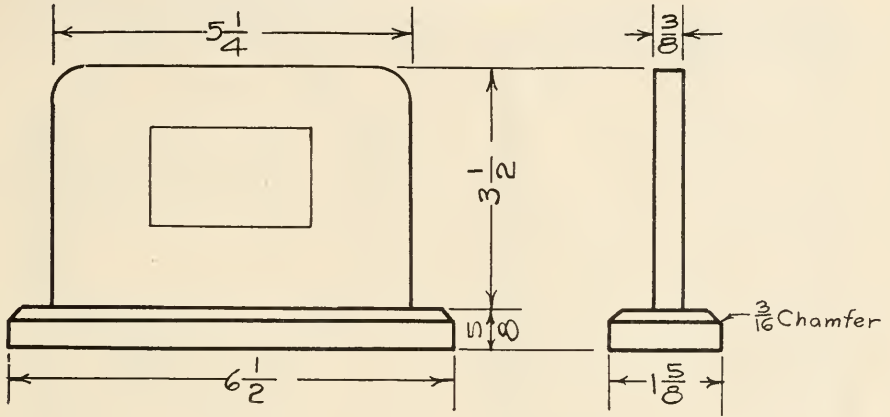

BREAD BOARD

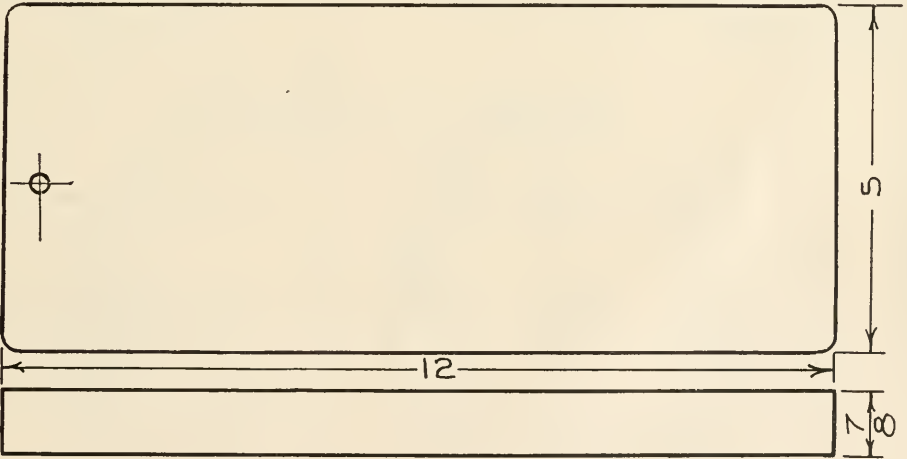

MATCH STRIKER

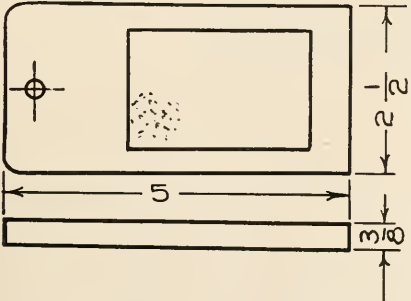

MATCH BOX HOLDER

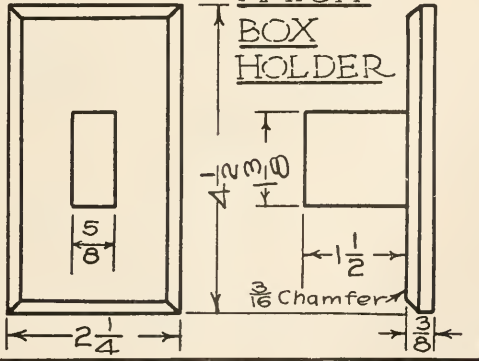

GAME BOARD

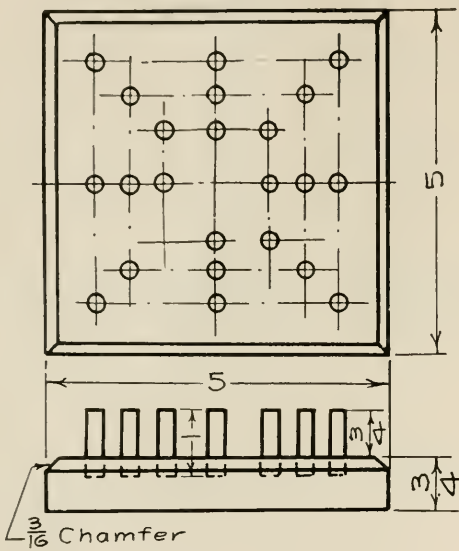

TEA-POT STAND

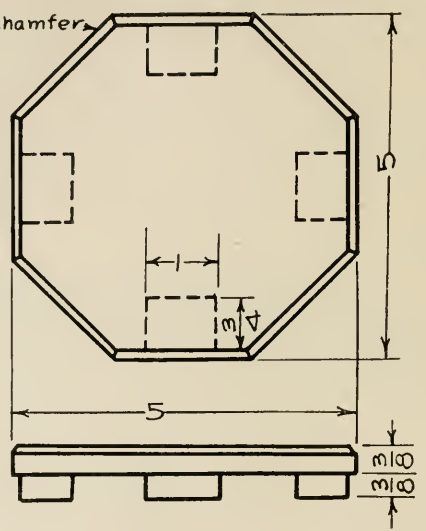

SPOOL

HOLDER

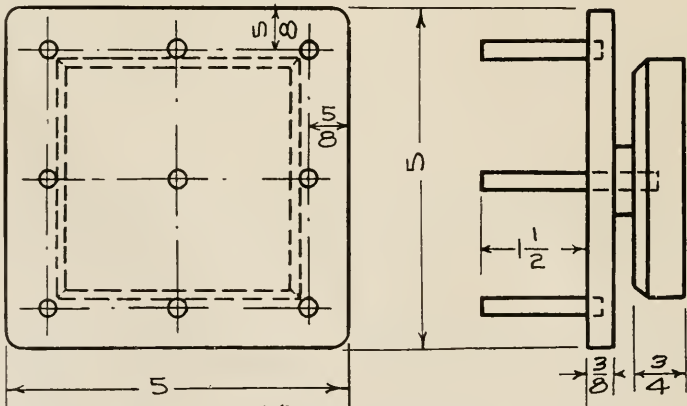

CLOTHES STICK

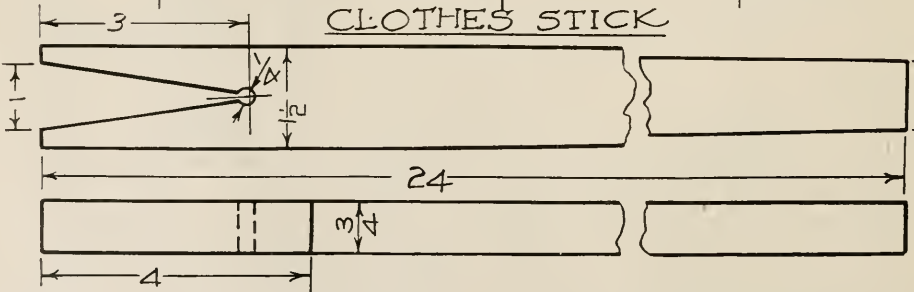

TOOTH-BRUSH RACK

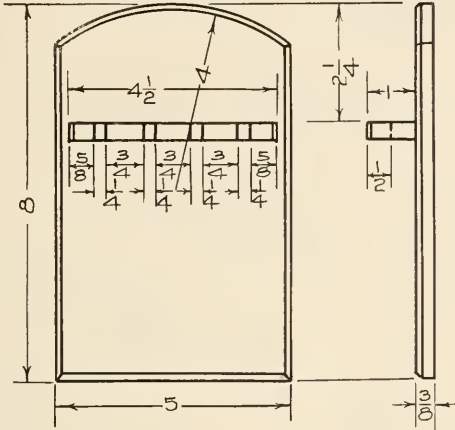

CAKE BOARD

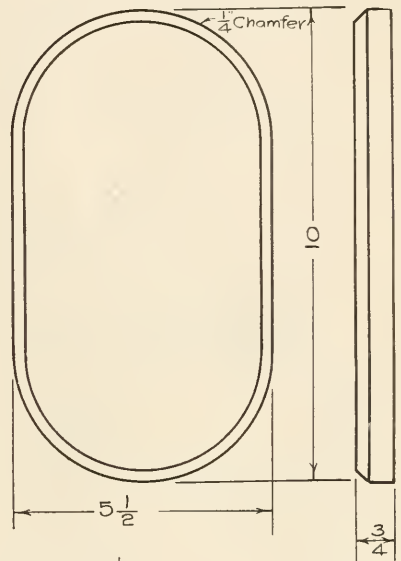

COLLAR AND TIE RACK

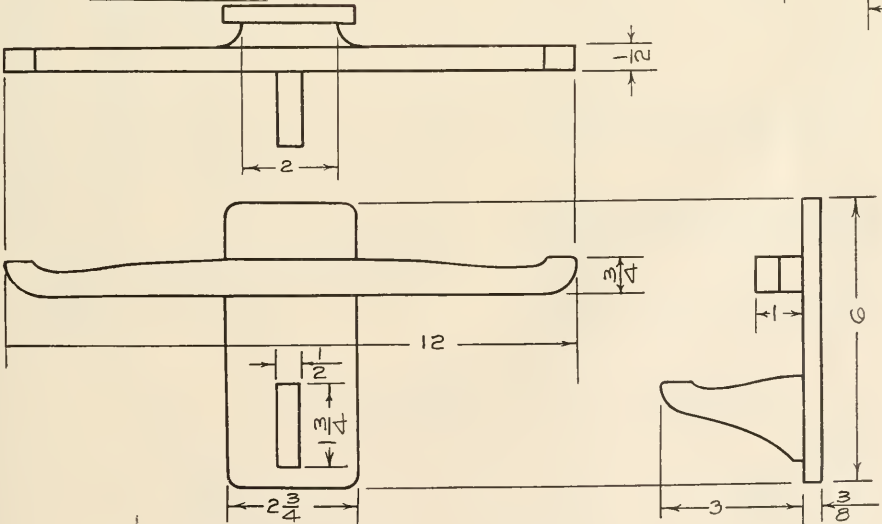

STATIONARY HOLDER

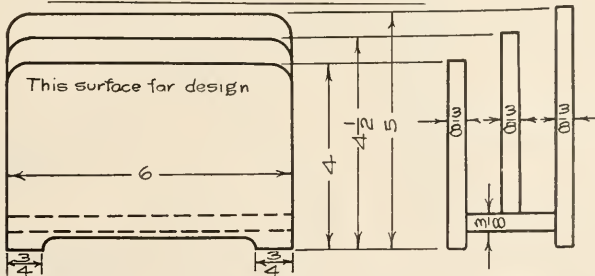

BOOKRACK ENDS

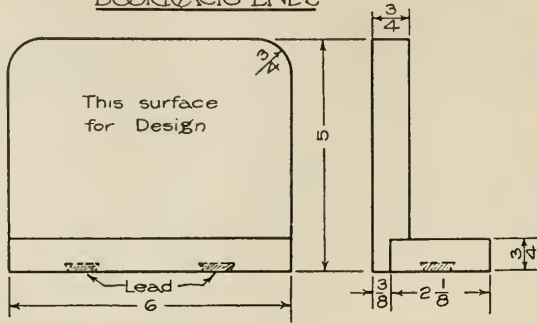

HANDKERCHIEF BOX

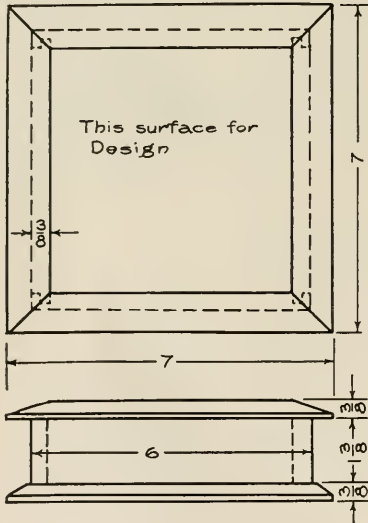

LETTER BOX

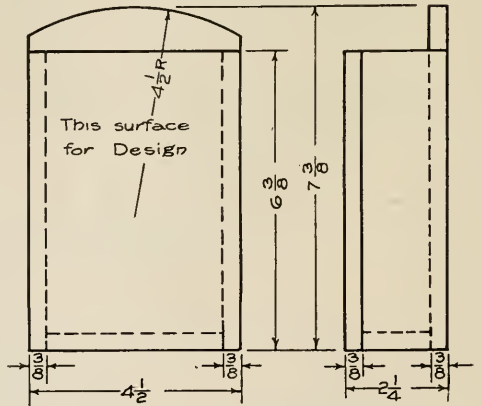

NUT BOWL

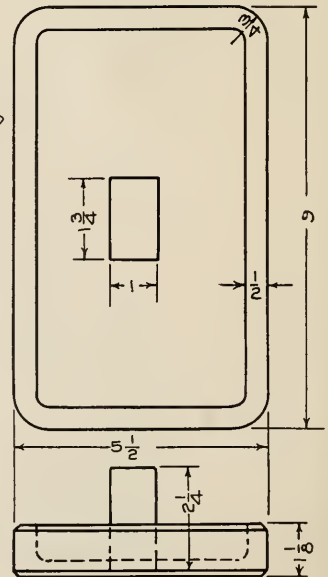

FOLDING CHECKERBOARD

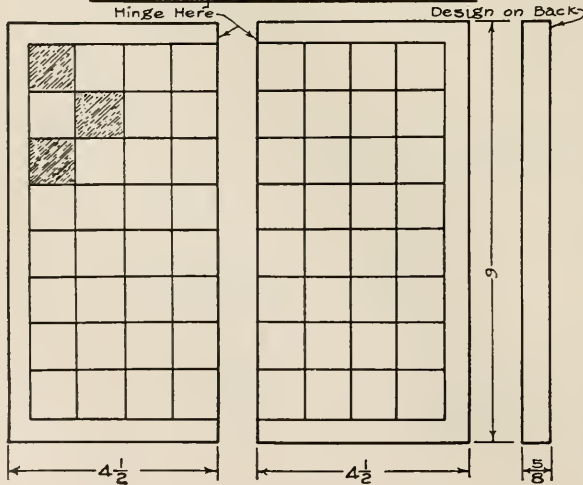

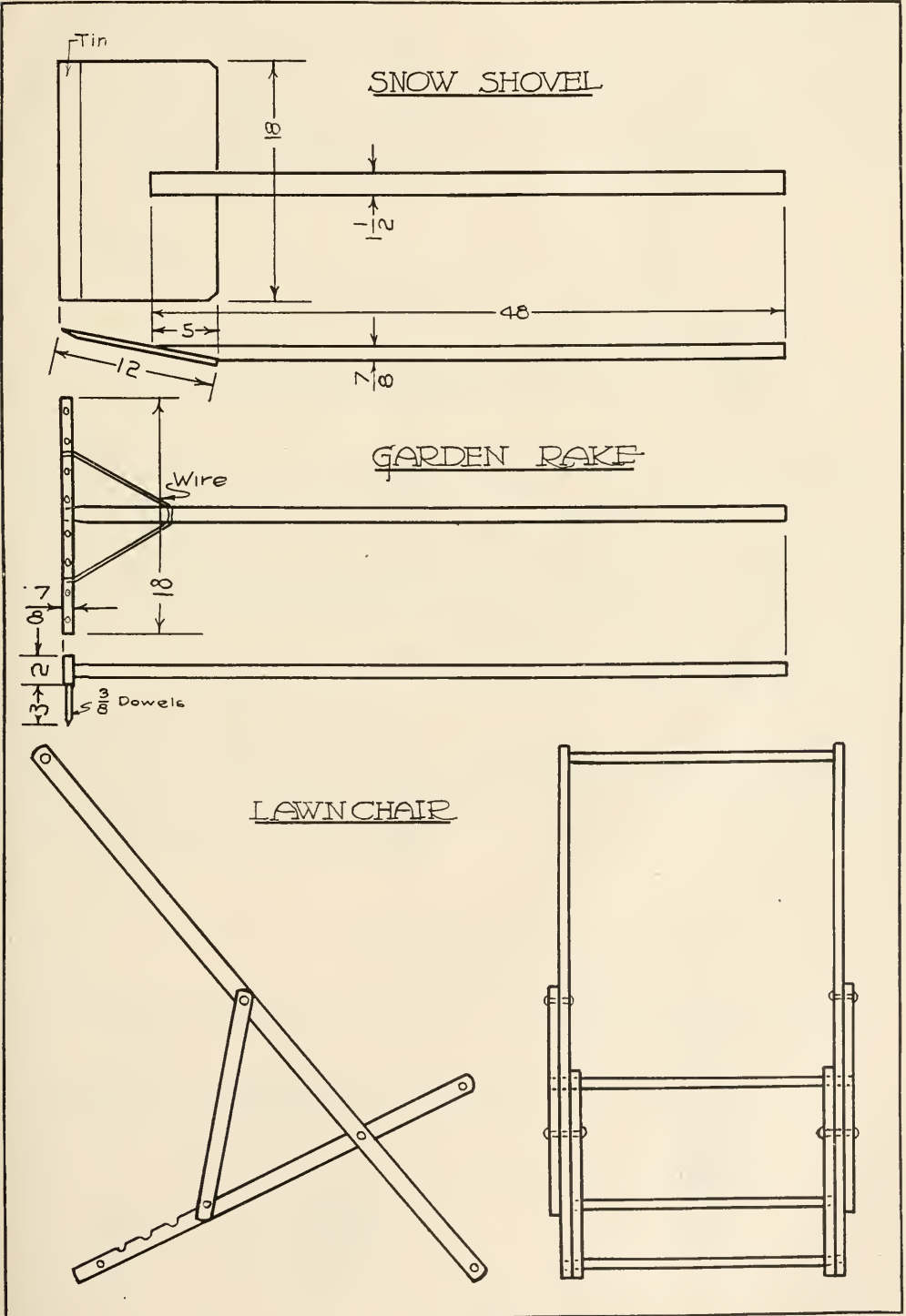

tube and connected directly to a single cell of a storage battery.

To use the tool, hold by the handle and touch the magnet to the hot steel, then lift up to see if the hot steel attracts the magnet. Hold it in contact with the hot work only an instant, but test often. As soon as the steel fails to attract the magnet it is just the right heat to quench.

MACHINE SHOP PROBLEMS

On the opposite page and at the bottom of this page are five small machine shop problems contributed by Edward Moeser of Buffalo, N. Y., who believes in giving high school boys small objects to make instead of large ones. He says that he realizes that the center punch and the drift, for

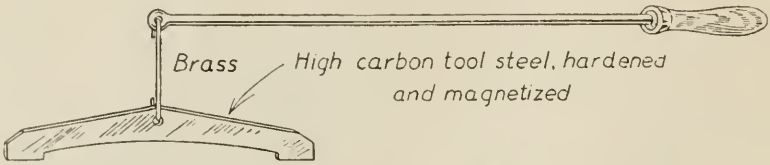

STEEL HARDENING TESTER MAGNET

By the use of this magnet the hardening point of any carbon tool steel can be approximately determined, tho of course not in so many degrees of heat. It is not so accurate as a pyrometer and in no way takes the place of one. It will however, enable a beginner to get a clear conception of what is meant by the "cherry red" to which the particular steel in use should be heated. It can also be easily demonstrated that the "cherry red" to which one steel should be heated is different from the "cherry red" for a steel having a different amount of carbon in it.

Whether the tool should be used to determine the hardening heat of every tool is a pedagogical question, but certainly a beginner should have some means of judging when a piece of steel is heated just hot enough.

—J. H. McCLOSKEY.

example, are small in size but the interest of the pupils in making these has been so great that they wanted to make more than the required one. He looks upon them, also, as good first steps in teaching straight turning, taper turning and knurling.

The parallel and the V-block are early problems in teaching the use of the planer or shaper. The tap wrench involves quite a variety of processes.

A PRINTING PROJECT

For a good project that correlates woodwork, art and printing the four pages of a leaflet shown on page 104 is suggestive. This was worked out by students in the Robidoux Polytechnic High School, St. Joseph, Mo., of which Ralph W. Polk is principal. Notice that the front cover page was printed directly from a block of oak wood.

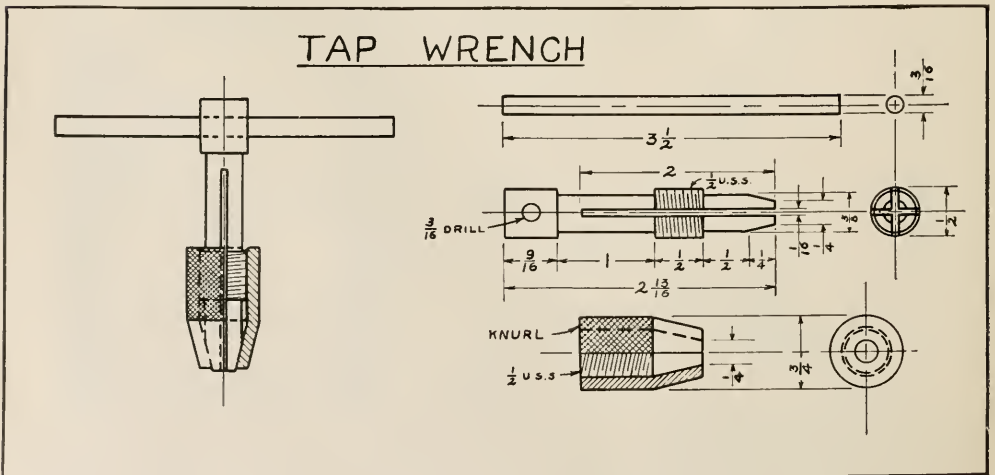

CENTER PUNCH

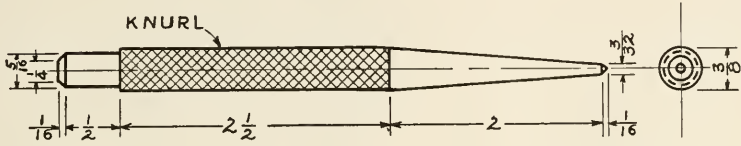

DRIFT

OTHER DIMENSIONS SAME AS CENTER PUNCH

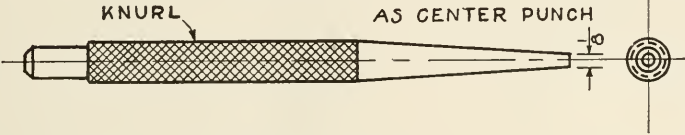

V-BLOCK

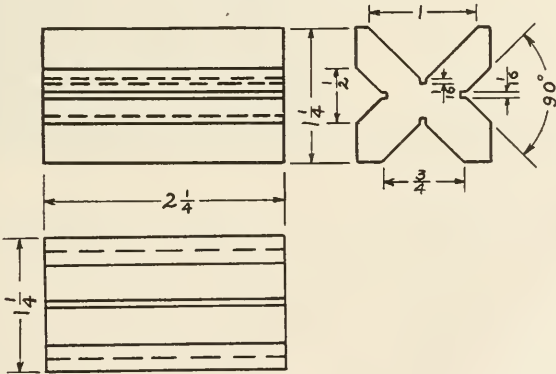

PARALLEL

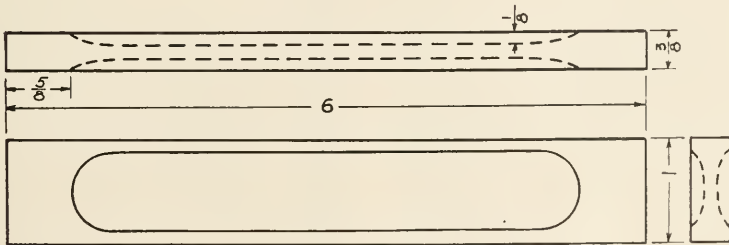

THE COVER of this folder was printed *direct* from an oak block prepared in the Woodshop. The printing was done by students of the Printing Department.

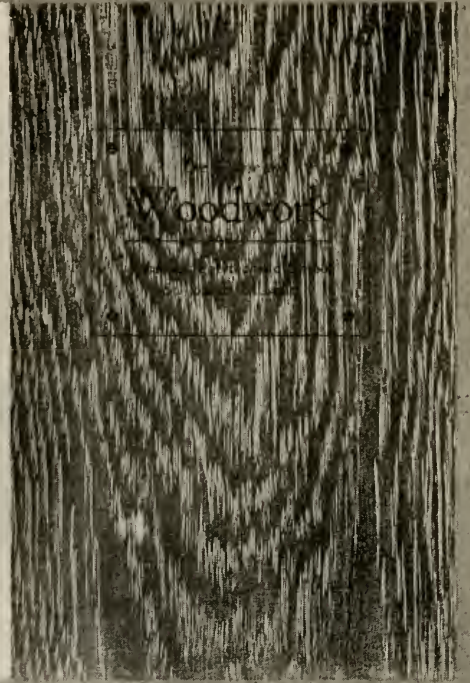

THE Course in Woodwork embraces a study of woods, tools and their uses, paints and finishes, elements of building construction, and simple drafting. It is designed to serve (a) boys who are interested in preparing for some phase of wood construction, either in building or in cabinet work, and (b) general students who wish to acquire some knowledge and experience in woodwork, and in the use of the more common tools.

The course is organized to cover four semesters, a double period per day. The activities in the woodshop include all the fundamental exercises necessary for the proper understanding of the common processes with hand and power tools, and practical work on such projects as will constitute a systematic order of helpful experiences. In addition to the work in wood, a portion of the time is devoted to instruction in drafting. Exercises are followed, actual draftings are made, and blue print work is done.

For general students who desire this work, a course of one period per day has been planned. This is a practical elective, for one year, or two years.

Individual instruction is carried on as widely as possible, and much time is devoted to individual projects chosen by the students. In the latter part of the course, special attention may be given to woodturning and lathe work, if desired.

The equipment for this work is ample for a thorough training in hand tool processes. In addition, a power saw and five wood lathes are at the disposal of the students. The drafting practice is had in a room especially equipped for that purpose.

The ability to use tools is essential to every young man, and this course is rich in the general information and experience that will be found valuable to all. A limited number of commercial students may choose Woodwork as an elective of their course.

CURRENT PUBLICATIONS

Sheet-Metal Drafting. By Ellsworth M. Longfield, Head of Sheet-metal Department, Boston Trade School. Published by McGraw-Hill Book Co., New York, N. Y. Size, 6 x 9 in.; 236 pages; 327 illustrations; published in both loose-leaf and book form; price \$2.25.

This is one of the well-known series of books especially prepared for the Extension Division of the University of Wisconsin. It is also well suited for use as a textbook for vocational, evening, and part-time schools. Each chapter deals with a fundamental principle, and contains correlated problems in mathematics. This arrangement is the result of several years' practical experience in teaching the subject.

School Sewing Based on Home Problems. By Ida Robinson Burton and Myron G. Burton. Published by Ginn & Co., Boston. Size, 6¼ x 9¼ in.; 393 pages; illustrated; price, \$1.60.

The advantages of a series of practical problems which interest every girl and have a value in the home, and reasonably sequential and progressive arrangement, are combined in this textbook. It consists of two parts: a main section describing many actual problems, and a supplement dealing with the different textiles and fundamental sewing processes. In each problem, in the main section, besides the necessary working directions, the use of the object is stated, with suggestions for outside readings; similar objects are described; and references are given to suitable paragraphs in the supplement. A thoughtful discussion of the conflicting problems which face the teacher of sewing precedes the main portion of the book.

The Manufacture of Pulp and Paper. Vol. II. Mechanics and Hydraulics, Elements of Electricity, Elements of Chemistry. By J. J. Clark and T. L. Crossby. McGraw-Hill Book Co., New York, 1921. Size 6x9 in.; 525 pages; illustrated; price, \$5.00.

This is the second volume of a series of five, prepared under the direction of the Joint Executive Committee on Vocational Education representing the pulp and paper industry of the United States and Canada. The object of the first two volumes is to give all the scientific and mathematical knowledge necessary for an understanding of the last three, which will deal with the preparation of pulp and the manufacture of paper. These latter volumes will be awaited with especial interest.

Pattern-Making. By Edward M. McCracken and Charles H. Sampson. Published by the D. Van Nostrand Co., New York, 1921. Size 8½ x 11¼ in.; 111 pages; illustrated; price, \$2.00.

This book describes a practical course in pattern-making suitable for use in technical, trade, and vo-

ational schools. Each pattern is designed to illustrate a principle, and is made difficult enough to demand interest and industry, but not so difficult as to cause discouragement. Chapters concerning woods of various kinds, the use of tools, and the principles of molding, are included as being information necessary to the equipment of a first-class pattern-maker.

Problems in Woodwork. Second edition, enlarged. By Edward F. Worst, Supervisor of Elementary Manual Training and Construction Work, Chicago. The Bruce Publishing Co., Milwaukee, Wis., 1921. Size 7¾ x 10¼ in.; 241 pages; 279 illustrations; price, \$2.50.

This manual is a revised edition of a book published in 1917. With the aim of bringing the work into closer relation with that of the grade teacher, a variety of materials are combined with the more usual type of woodwork, as may be seen from the titles of some of the chapters: Metal and Wood; Ash Splint Work; Cane Weaving; Rush Seating; Hickory Splints; Upholstery; Round and Flat Reed Weaving; Textiles and Wood. An interesting feature is the chapter on electric lamps and parchment shades.

Gasoline Automobiles. By James A. Moyer. McGraw-Hill Book Co., New York, 1921. Size, 7½ x 5 in.; 261 pages, 212 illustrations; price, \$2.00.

This is a brief, readable book on the essential principles of automobile construction and operation. "It is expected to furnish practical help to drivers who, when faced by ordinary operating troubles, want to know how to locate the cause and apply the remedy." It is also intended for students in automotive engineering. The distinctive feature of this book is that it deals not with a multitude of details but with principles.

Wood-block Printing. By F. Morley Fletcher, director of Edinburgh College of Art. One of the "Artistic Crafts Series" published by Sir Isaac Pitman & Sons, London, 1916. Size 7 x 4¾ in.; 132 pages; price, \$3.50.

This book is a description of the craft of wood-cutting and color printing based on the practice of the Japanese. It gives illustrations of the tools used in both the cutting and the printing processes and tells how to use them. It includes several reproductions from wood-block prints, and contains one original print in colors designed and cut by the author, and printed on Japanese paper.

Color Tablet. By H. Francis James and Edna G. Benson. The Bruce Publishing Co., Milwaukee, 1920. Sixteen plates 11½ x 8¾ in., gummed on one edge in an envelope.

These plates are to be used by pupils in a series of color lessons, beginning with simple blocks of primary colors and ending with the side of a furnished room, costumes of school girls and a view of a house and garden.

The plates are printed on paper that will take color.

First Lessons in Batik. By Gertrude C. Lewis. The Prang Company, 1921. Size 10 x 7½ in.; heavy paper covers; 88 pages, many halftone illustrations, one color plate; price \$1.60 postpaid.

This attractive volume gives not only facts about the technic of the art but it gives a great variety of suggestive designs, both ancient and modern. Some of the designs were taken from specimens of Japanese work in the Field Museum of Natural History in Chicago; others from museum collections in New York, and many from private collections, and from present-day artists in batik.

Lettering for Commercial Purposes. By Wm. Hugh Gordon. Published by the Signs of the Times Publishing Co., Cincinnati, O. Size 9x12 in.; 173 pages; with many illustrations; price, \$3.50.

This is a simple and untechnical explanation of the methods found most practical in the production of letters for commercial purposes, including show-card writing and lettering, posters and advertising matter for single-copy jobs or process reproduction. The author speaks from years of experience and association in the craft. The illustrations represent his personal work and conceptions; some are imitative, others are modifications of existing letter and type styles and models in original style. All are designed with reference to (1) simplicity of form without loss of effect or basic principle, (2) adaptability to rapid production, (3) artistic arrangement, (4) correspondence of letter style with subject.

A Handbook of Laboratory Glass-Blowing. By Bernard D. Bolas. With numerous diagrams in the text by Naomi Bolas. Published by George Routledge & Sons, Ltd., London; E. P. Dutton & Co., New York, agents. Size 5x7½ in.; 106 pages; price, \$1.50.

The object of this book is not to cover the entire field of commercial glass-blowing, but to give the necessary information for such work as will find practical application in the laboratory. The making of thermometer bulbs, pipettes, absorption bulbs, thistle funnels, air traps, sprays, arresters, filter-pumps, stop-cocks, and many other kinds of apparatus, is described.

Perspective. The Old and the New Method. By Archibald Stanley Percival. Published by Longmans, Green & Co., London and New York. Size

5½x8¾ in.; 42 pages; with diagrams; price, \$1.60.

This handbook is intended for use in drawing classes and for all junior art students. It gives a clear, concise, yet scientific explanation of the rules and problems of perspective, with or without the use of vanishing points.

Elementary Qualitative Analysis of the Metals and Acid Radicals. A Laboratory Manual. By Frederick C. Reeve, Acting Head of the Department of Physics and Chemistry at the East Side High School, Newark, N. J. Published by D. Van Nostrand Co., New York. Size 5¼x8 in.; 143 pages; price \$1.50.

The following special features of this book are noteworthy: (1) the main scheme of analysis is presented, without the complication of special conditions; (2) working directions for each test, rather than its description, are given; and (3) chemical equations are written for all reactions.

How to Read Blueprints by W. J. Howard. Published by The Charles T. Pownor Co., Chicago. Size 6¾x4¾; 165 pages, 48 illustrations.

The aim of the author in presenting this little book has been to give the results of his observation and practical experience in such form as to be helpful to the estimator, the mechanic or the builder. It is really a handbook of information relating to building construction, and as such it includes a typical city building ordinance and sample specifications.

RECEIVED

An Analysis of the Work of Juniors in Banks. By Eva Jessup and Clyde Blanchard. Issued by The University of California in cooperation with the State Board of Education, Berkeley, California, May, 1914. Part-Time Education Series No. 5. Bulletin No. 4.

Educational Work of the Commercial Museum of Philadelphia. By Charles R. Toothaker, curator. Bulletin, 1920, No. 13, Bureau of Education, Department of the Interior.

Annual Report of the Public Schools of Johnstown, Pa. 1920. Published by order of the Board of School Directors.

Instruction for Bird Banding. By Frederick C. Lincoln, Assistant Biologist. U. S. Department of Agriculture Department. Circular 170. Contribution from the Bureau of Biological Survey, E. W. Nelson, Chief.

The Worker. Bi-monthly magazine, designed and printed by students of Boys' Vocational School, Newark, N. J. The names of stonemen and pressmen appear on the executive staff, along with those of editors and reporters.

Helping an airplane
to get back in
the air



No. 1555

(Illustrated) Length
17 in. 3-jaw chuck for
round shank drills up
to 1/2 inch.

No. 555

Length 17 1/2 in. 2-jaw
chuck for round or
square shank drills
up to 1/2 inch.

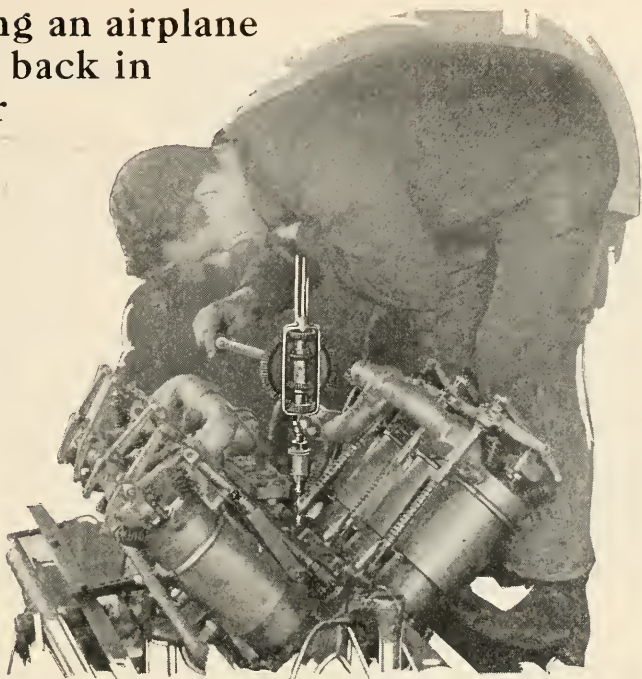

“A ‘Yankee’ Drill Works Where Others Can’t”

“A ‘Yankee’ Breast Drill No. 1555 set on the DOUBLE Ratchet makes it easy to drill that cam shaft bushing. Not room enough to turn the crank completely—that’s why I use this drill.

“The slightest movement of the crank, back and forth, and the drill cuts continuously. The *only* tool for the job.

“By a touch on the ratchet shifter (on cylinder between central gears) the action can be changed to Plain Drill, Left-hand Drill, Right-hand Drill, DOUBLE Ratchet; and in the last position, the gears are locked for changing drills. The *only* drill with these movements.

“To change speed, shift the lever at the hub of the crank. Works instantly and without removing drill from work.”

Some Other “YANKEE” Tools

Spiral Screw-drivers
Ratchet Screw-drivers
Plain Screw-drivers
1 1/2 to 30 in. blades
Ratchet Chain Drills

Ratchet Hand Drills
Ratchet Bench Drills
Automatic Push Drills
Ratchet Tap Wrenches
Bench Vises, removable base

Dealers everywhere sell “Yankee” Tools

NORTH BROS. MFG. Co., Philadelphia

This book FREE to you

Write today. Contains over a hundred illustrations of tools—some of them doing things you would never think could be done.



“YANKEE” TOOLS

Make Better mechanics

Redwood Provides Perfect Gluing Surfaces

The uniform cell structure of Redwood gives it a remarkably even texture—surfaces that give glue countless anchorages, that also permit of an attractive wax, varnish or paint finish. Besides being light in weight, soft and odorless, Redwood is insect and vermin proof. Properly cured it does not shrink, warp nor swell.

Largely used for incubators, screen frames, clothing chests and shirtwaist boxes, for cigar and candy boxes, bird houses, etc., and for storage battery separators.

Vertical grain up to 12" wide—
slash grain any desired width.
thicknesses—3/16" and up.

Samples of Redwood in various thicknesses, both slash and vertical grain will be gladly sent to manual training instructors on request.



2090 McCormick Bldg., Chicago
New York Kansas City

THE PACIFIC LUMBER CO.
San Francisco Los Angeles

EXPORT COMPANY:
A. F. THANE & CO.
233 Broadway, New York City
311 California Street, San Francisco

*The Largest Manufacturers and Distributors of
California Redwood.*

Members of the California Redwood Association

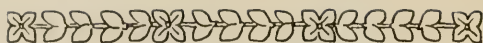

FIELD NOTES—(Continued)

eral feeling of "I wish it were over." There is a summer school on the North Shore, Boston, where the students appear to have none of this feeling. It is the Sjolund Model Dock Yard School of the North Shore.

This school of hand work, or manual training, or sloyd—whatever name may suit best—is a school that has for its purpose the joyous summer occupation of children thru the construction and decoration of toys of many kinds, and particularly of miniature boats. Boat races are held at regular intervals, also exhibitions of the various other articles produced.

This school, which was started in the summer of 1912 with only ten pupils in attendance, has come to be a very popular summer attraction for the children who spend the summer at North Shore. This summer it has had one hundred pupils in attendance.

REPORT ON PART-TIME SCHOOLS

A BRIEF analysis of the continuation and evening school laws of each state, as well as those prescribing day-school attendance, is shown in a chart recently issued by the U. S. Department of Labor thru the Children's Bureau, entitled "State Compulsory School Attendance Standards Affecting the Employment of Minors, January 1, 1921."

This chart shows that twenty-two states now have compulsory provisions for continuation school attendance. In three of these states, however, the establishment of such schools is not compulsory, and in one, the school authorities are merely empowered, not compelled, to establish part-time schools and to require attendance. The age limit to which the compulsory attendance provisions apply varies, ten states requiring attendance up to eighteen years of age, one state up to seventeen,

Marqueterie, Inlay Borders and Purflings for

Manufacturers and Vocational
Schools

Insets for Trays, Panels, Cabinets, etc. carried in stock.
Natural and Transformed Veneers in great variety.
Lines in Holly, Satinwood, Box, Mahogany and Black

J. BERNARD & CO.

422 to 30 East 53rd St. New York

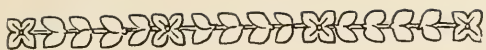

FIELD NOTES—(Continued)

and eleven states up to sixteen. The amount of attendance is from four to eight hours weekly; the laws of each state either specify or imply that this period shall be counted as part of the child's legal working hours.

U. S. CHAMBER OF COMMERCE CALLING FOR BETTER SCHOOLS

PPOINTING out that the future welfare of American business and the efficiency of the American public schools are bound together, the Chamber of Commerce of the United States has inaugurated a movement to stimulate the interest of business men in local school affairs. A pamphlet on education, sent out by the National Chamber to its fourteen hundred member-organizations, calls upon business men everywhere "to aid actively in bringing the local public schools to a high plane of effectiveness."

This preliminary pamphlet will be followed up by four others. They will deal with: building and equipment; health and physical education; the teacher; and laws and administration.

The initial statement includes interesting and in some cases startling facts concerning the number of students who drop out before high school and college, illiteracy, overcrowding of classes, absences, and shortage of teachers. According to the pamphlet, schools of the United States cost about 760 million dollars a year.

THE VOCATIONAL EDUCATION ASSOCIATION of the Middle West will hold its eighth annual Convention in Milwaukee, Wisconsin, Jan. 11-12-13-14, 1922, according to an announcement recently received.

THE FAIRCHILD PUBLICATIONS competition for ideas in advertising for apparel and fabrics offers \$1,000 in prizes for those designs or that copy, or combination of design and copy, which, in the

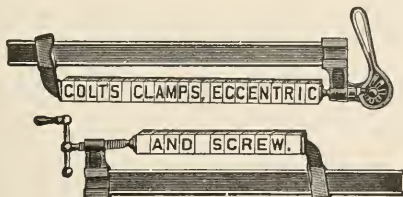

Forty styles of Quick Acting Clamps for the Worker in Wood, Cement and in the trades generally.

Your dealer will supply you.
Ask for catalog No. 296.

BATAVIA CLAMP CO.

237 Center Street

BATAVIA, N. Y.

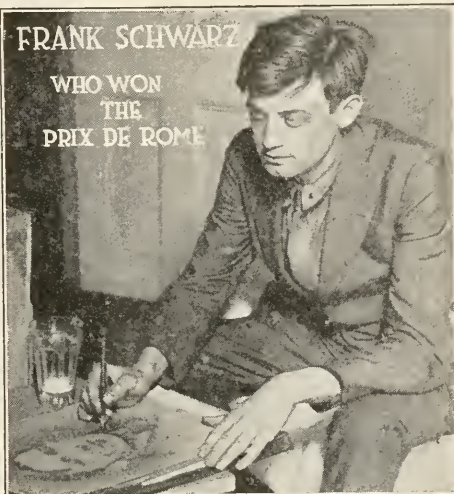

FRANK SCHWARZ

WHO WON THE PRIX DE ROME

Art Students

cannot do better than be guided by the winner of the Prix de Rome! He uses

VENUS PENCILS

In an interview he said, "I have always used VENUS PENCILS. They give me an even smooth stroke of wonderful texture and I prefer them above all others."

The above copyrighted photograph sent to the American Lead Pencil Company by Underwood and Underwood, photographers, shows Mr. Frank Schwarz, the winner of the most coveted of all Art Awards using a VENUS Pencil.

VENUS PENCILS

17 Black Degrees 3 Copying

For bold, heavy lines . 6B-5B-4B-3B
For writing, sketching 2B-B-HB-1-H
For clean, fine lines. 2H-3H-4H-5H-6H
For delicate, thin lines . 7H-8H-9H

Plain Ends, per doz. \$1.00
Rubber Ends, per doz. 1.25

At Stationers and Stores throughout the World.

American Lead Pencil Co.

208 Fifth Ave., Dept. A., N. Y.

and London, Eng.



The largest selling *Quality* pencil in the world

Van Nostrand Texts

SWOOPE'S LESSONS IN Practical Electricity

AN ELEMENTARY TEXT BOOK

Sixteenth Edition, Rewritten,
Revised and Enlarged

By HARRY NOYES STILLMAN

*Late Instructor at the Spring Garden Institute,
Philadelphia*

and ERICH HAUSMANN, E. E., Sc. D.

*Professor of Physics at the Polytechnic Institute
of Brooklyn and Fellow of the American
Institute of Electrical Engineers*

A thorough up-to-date course in beginning electricity giving a complete treatment of the elementary theoretical aspects as well as the practical use of direct and alternating currents in industrial applications of electricity.

"The book is so good that its merits need not be concealed."

A. E. WATSON,
Brown University.

"I regard this as the most modern and understandable text of its kind."

H. M. RUGG,
Former Director
Associated Y. M. C. A. Schools.

630 Pages— $5\frac{1}{2} \times 7\frac{1}{2}$ —488 Pictures
Postpaid \$2.50

Mechanical Drawing for Industrial and High Schools

By C. C. LEEDS

*Professor of Mechanical Drawing, School of
Applied Industries, Carnegie Institute
of Technology.*

This course covers the use of drawing tools, plane projection, conic sections, construction of curves, sketching, lettering and practical machine and structural drawing.

"The subject is handled by one who has been there." Non-essentials are eliminated, essentials simplified and presented clearly. The plates are adequately thoroughly drawn, whether freehand or mechanical, and comprehensive, in their scope; the text is concise, and orderly. This is a book that gets down to business.
THE SCHOOL ARTS BOOK, APRIL 1911.

94 Pages—39 Lessons— $10\frac{1}{2} \times 8$ inches
Cloth—Postpaid \$1.50

Specimen Copies Sent "On Approval"

D. Van Nostrand Company

Publishers and Booksellers

8 Warren Street

NEW YORK

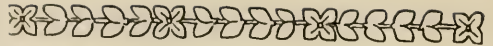

FIELD NOTES—(Continued)

judgment of the jury, possess the greatest selling force, originality, artistic merit and technical excellence. There will be six \$100 prizes for ideas in advertising, one for each of the following: women's apparel, men's apparel, fabrics, costume accessories, and financial institutions, the remaining prize of \$100 to be awarded to the best of these five. There will be sixteen prizes of \$25 for the designs or copies next in merit. The contest closes November 21, 1921. Send all material to the Fairchild Publishing Co., 8 East 13th St., New York City.

HIGH SCHOOLS NEED MORE ART TEACHERS

EXAMINATIONS for license as teacher of freehand drawing in high schools will be conducted by the board of examiners, at the Board of Education, Park avenue and Fifty-ninth street, Manhattan on Monday and Tuesday, September 19th and 20th, beginning at 9 a. m., each day.

The high schools employ over one hundred teachers of drawing, and there is at present a considerable number of vacancies. Under the new salary schedules the minimum salary of an assistant teacher of drawing is \$1,900 per annum, the maximum, \$3,700, for the thirteenth and subsequent years of satisfactory service.

A circular of information regarding the examination may be had on application to the Board of Examiners, 500 Park Avenue, New York City.

SALMON FISHERS of Astoria, Oregon have been offered a course in care and operation of gas engines as applied to motor boats. The course was established by the local school board in connection with the State Board for Vocational Education. The course proved so popular that two instructors had to be employed.

Let Your Pupils BUILD PHONOGRAPHS Start Your Boys in Business in the Class-room

Building phonographs is ideal shop-work, because it is easy, by our methods, and yet requires precision and delicacy of workmanship to achieve best results. Let the boys build their own machines, either to sell or take home as a source of real, lasting pleasure. They will enter the work with new enthusiasm. The results will be splendid. You will add greatly to your popularity and success as an instructor. We supply blue prints, tone-arms, motors, case material and all accessories at lowest prices. Complete instructions furnished. Materials the very best, fully guaranteed. Our machines play any make record.

Write today for full particulars about our co-operative plan for manual training teachers. We plan the work for you.

Fine Illustrated Catalog Free.

FEDERAL SUPPLY COMPANY

410 West 28th Street

Indianapolis, Ind.

TURNED FROM BEAUTIFUL BLACK WALNUT



A SET OF PATTERNS AT COST

SQUARE BLANKS, selected and sawn to develop the "figure" either in "curly" or Circassian, for dresser or Vanity Cases, can now be had in sets of four or multiples of same at the same prices as for lots of one dozen.

Delivered Free in the U. S. A.

Write for List 46

Manufactured by **FRANK R. PORTER** WASHINGTON, D. C

A New Automobile Text

An Ideal Combination of Practice and Theory

Part I Contains Full Instructions for doing 118 Practical Automobile Jobs.

Part II Presents Clearly the Principles of Construction and Operation.

WRIGHT'S AUTOMOTIVE REPAIR

A NEW INSTRUCTION MANUAL OF REPAIR JOBS
FOR THE GENERAL REPAIRMAN AND OWNER

By **J. C. WRIGHT**, B. S. and M. S., Chief, Industrial Education Service, Federal Board for Vocational Education; formerly Educational Director, Rahe Auto and Tractor School, Kansas City, Mo.

A practical, thorough instruction manual of repair jobs for the general repairman and the owner. It also makes an ideal text-book for use in automobile schools and classes, being extremely flexible and adaptable for use in 50-hour, 100-hour or 300-hour courses.

About 500 pages, 6 by 9, fully illustrated with cuts of exceptional clearness. Durable cloth binding. The price has not yet been set.

Send for a Sample Job—or Better still, for a Copy of the Book on Free Examination.

JOHN WILEY & SONS, Inc.

432 Fourth Avenue
New York

WILEY FREE EXAMINATION COUPON

John Wiley & Sons, Inc., 432 Fourth Ave., N. Y. City
Gentlemen: Kindly send me for 10 days' free examination **WRIGHT'S AUTOMOTIVE REPAIR** (as soon as issued): I agree to remit the price of the book within 10 days after its receipt or return it, postpaid.

Name
School..... Position.....
Address

M. T. M. -9-21

Build Your Own PHONOGRAPH

Instructive—arouses pupils enthusiasm—provides one of the best problems in cabinet making.

Let Your Pupils Build
Choraleon Phonographs

We furnish plans, blue prints, motors, tone arms, case material—in fact, everything required. Full instructions. Choraleon's have fine tone. Play any record. Ask for particulars.



CHORALEON PHONOGRAPH CO.
921 7th St., Elkhart Ind.

TOOLS

For Manual Training Shops.
Send your inquiries to and get the especially low prices quoted by

MONTGOMERY & CO. Inc.,
105 Fulton Street New York City

PRANG ART BOOKS

"Theory and Practice of Color," by Snow and Froehlich. The most authoritative work on "Color." Illustrated with hand-painted "Color Charts." Price \$4.00; by mail, \$4.25.

"Art Simplified," by Pedro J. Lemos and John T. Lemos. A book of practical instruction in Art for advertisers, commercial artists, teachers and students. 22 full-page plates. Price, \$4.00; by mail, \$4.25.

"Lettering," by Thomas Wood Stevens. The standard work on the subject of lettering for students, designers and artists. 119 full-page plates. Price, \$3.00; by mail, \$3.25.

"Pencil Sketching Portfolios, Nos. 1 and 2," by George W. Koch. Each containing 15 plates of beautiful pencil sketches reproduced by the offset process. Portfolio No. 1, \$1.00; Portfolio No. 2, \$1.00.

"A Short History of Art," by De Forrest and Caffin. The most comprehensive single volume on the subject. Price, \$4.00; by mail, \$4.25.

"First Lessons in Batik," by Gertrude C. Lewis. A practical handbook, giving full information for Batik dyeing and Tie-Dyeing. Beautifully illustrated. Price, \$1.50; by mail, \$1.60.

"Permodello Modeling," by Snow and Froehlich. Gives full directions for innumerable uses of "Permodello," the permanent Modeling Clay which sets like concrete without firing. Beautifully illustrated. Price, \$1.50; by mail, \$1.60.

"Spoonbill Pen Lettering Tablets." A Tablet of exercises and drills for use with the "Spoonbill Pen" that makes lettering as easy as writing. Per tablet, 75c. "Spoonbill Pens," 3 sizes, per dozen, \$1.20.

"Constructive Anatomy," by L. J. Bridgeman. By the head of the department at the Art Students' League. Price, \$7.50.

Send for Descriptive Circulars

THE PRANG COMPANY

1922 Calumet Ave., Chicago
30 Irving Place, New York

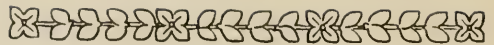

TRADE NOTES

NEW TRY- AND MITRE- SQUARE

An improved Try- and Mitre-Square, designed especially for carpenter's use, has just been put on the market by The Lufkin Rule Company, Saginaw, Michigan. It consists of a substantial steel blade marked both sides 8ths and 16ths, with figures and lines clear and distinct, fitted with a movable head which can be securely clamped at any point.



Primarily a Try- and Mitre-Square with blade adjustable in length, it serves well, also, because of this adjustable feature as marking gage, depth gage, for measuring mortises, etc.

This square is to be known as Lufkin Universal No. 65 and will be made in two lengths—9- and 12-inch blade. It is a high grade tool, accurate, durable and well designed, and will sell at a popular price.

ELGIN JUNIOR BAND SAW

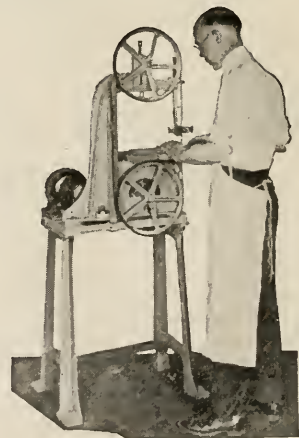

A Portable Bench Band Saw

For Wood or Soft Metal. Easy to Carry. Comes equipped with motor, wire switch, light plug and safety guards.

15 days free trial anywhere in U. S. A.

THE ELRICK MFG. CO.
ELGIN, ILLINOIS

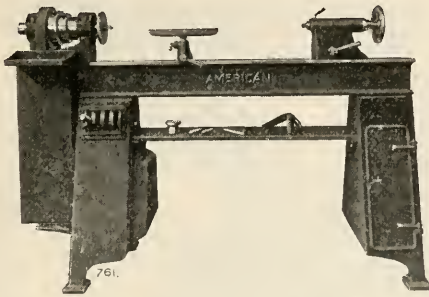

Manual Training Lathe with Motor
in Base—24" to 72" Centers

AMERICAN School Equipment

High Quality Machines
at Moderate Cost

SAW BENCHES
JOINTERS
PLANERS
BAND SAWS
WOODWORKERS

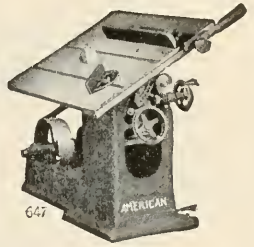

AMERICAN SAW MILL MACHINERY CO.

142 MAIN ST., HACKETTSTOWN, N. J.

V. & B. Tools

A Complete Line of Hammers, Braces,
Planes, Screw Drivers, Pincers,
Bits, Etc.



ALL V. & B. TOOLS ARE
INDIVIDUALLY
TESTED.

Write for Complete Circulars.

Vaughan & Bushnell Manufacturing Co.

2114 Carroll Ave.

CHICAGO

Specialists in
Manual Training Lumber

Maisey & Dion
Hardwoods

KILN DRIED AND AIR DRIED

OFFICE & YARDS 2349 TO 2423 So. LOOMIS ST.

TELEPHONES

CANAL 1830

CANAL 1831

CANAL 118

CHICAGO

THE

Great Central Market



ORDER NOW—DIRECT FROM US

Mechanical Drawing Instruments

AT OUR ATTRACTIVE WHOLESALE PRICES
AND SAVE ONE-HALF OF RETAIL PRICES

Set of Instruments as per Photo \$6.00

Construction of Solid Nickel Silver and Steel—Pocket
Case 8½ Inches by 4 Inches, and Lined with Velvet.

A Set of Instruments Every Manual Training Student
Can Afford—at a Big Saving and Perfect Satisfaction

Send for Catalog on Other Sets, Etc.

National Instrument Company

4700 North Hamilton Ave., Dept. M., Chicago, Ill., U. S. A.



Improved Drawing Instruments

We are again supplying our College and School Styles of Drawing Instruments. With improvements we have been able to make in the design and construction these set an advanced standard for instruments of precision designed for classroom use.

Attractive Prices

Send us your list of requirements for your next term classes. If you contemplate any change in address also, let us know. We wish to keep your name and address correctly.

The Frederick Post Company
DRAWING MATERIALS
Irving Park CHICAGO, ILL.

SAW TABLES

For MANUAL TRAINING

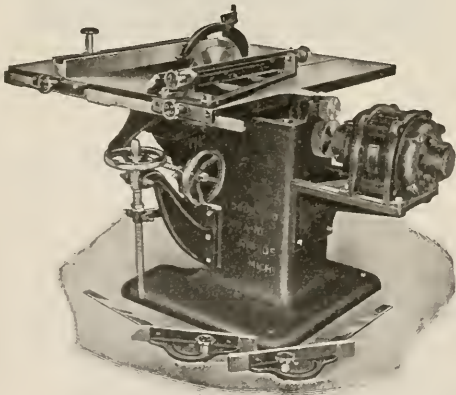

This cut shows our motor driven spiral gear saw table. No countershaft, no belts. Tilting or stationary tops. Write for circular and prices on our entire line. Address

ALEXANDER DODDS CO.
451-453 Monroe Ave., N.W.
GRAND RAPIDS, MICHIGAN, U. S. A.

MITER SAW BENCHES

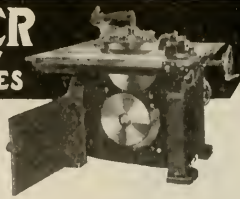

The "Tannewitz" Universal Double Revolving Arbor Saw Bench with Sliding Table and Taper Pin Gauges is the only logical tool for the wood shop where frequent setting up is the rule and accuracy is the goal. Send for bulletin.

THE TANNEWITZ WORKS
GRAND RAPIDS MICH

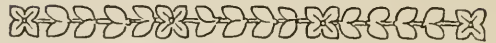

TRADE NOTES—(Continued)

A GIANT WOOD-TURNING LATHE

A decided accomplishment in lathe manufacture was the building of a wood-turning lathe 32" diameter swing with bed 62 feet long.

The specifications for this lathe were written up by the United States government during the year 1919 and there were only two manufacturers in this country who put in a bid at all on building this tool, and the government awarded the contract to the Oliver Machinery Company of Grand Rapids, Michigan.

We understand that this lathe, with its two power feeding carriages, is used for turning spars or ship masts.

A GOOD ARGUMENT

The argument of the American Lead Pencil Co. this month is essentially this: The pencil that is good enough for the winner of the Prix de Rome is none too good, but just good enough for every student of drawing in American public schools.

This is a good argument. If Frank Schwarz prefers the Venus Pencils, and for a good reason, that fact is sufficient reason why I should prefer them, too, or at least try them in comparison with others.

LETTERING INSTRUMENT

Teachers and students of mechanical drawing will be glad to learn of a new and distinctly practical tool for use in lettering.

It is called the Ames Lettering Instrument, having been originated by Prof. O. A. Olson of Ames, Iowa. Among the many devices for lettering, this instrument is unique, being extremely simple in design, light and compact. It consists of a celluloid disc held so as to rotate on a U-shaped retaining ring on which is attached a bar, which serves as a base and straight edge.

A series of holes in the disc enable the user to draw with accuracy and ease the guide lines for

"STAR" LATHES

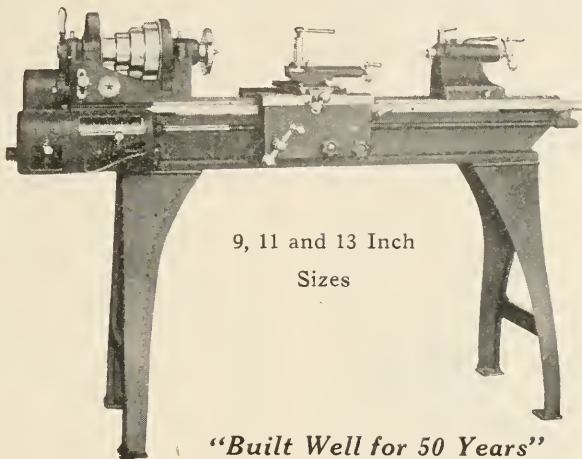

9, 11 and 13 Inch
Sizes

"Built Well for 50 Years"

THE SENECA FALLS MFG. CO., Inc.
SENECA FALLS, N. Y.

Grammar Grade Problems in Mechanical Drawing

A textbook for students in the 7th and 8th grades

By Charles A. Bennett

*Formerly Professor of Manual Arts
Bradley Polytechnic Institute*

Price, 44 cents

Discount in Quantities

The first successful text for use in teaching the fundamentals of mechanical drawing to grammar grade students. The use of this book by students in the 7th and 8th grades eliminates "hit and miss" methods and makes possible the teaching of mechanical drawing in grade classes in as thorough a manner as woodworking or any other subject.

Teachers having in charge large classes, whether giving individual, or class instruction, or both, will find this text in the hands of students a wonderful help. This is especially true where only a very limited time is devoted to the work.

THE MANUAL ARTS PRESS, Peoria, Illinois

"JORGENSEN" PEERLESS HAND SCREWS

A single clamp will adjust to any of these positions or any modification of them.

Steel Spindles
Steel Nuts
Hard Maple Jaws

**Adjustable
Clamp Co.**

216 N. Jefferson St., Chicago

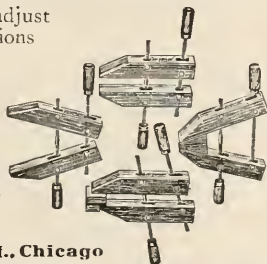

NIAGARA SHEET METAL WORKING TOOLS

We completely equip shops for instruction in Sheet Metal Work. This branch is steadily gaining in importance as sheet metal is being used as a substitute for other materials. Write for a copy of our latest catalog.

Niagara Machine and Tool Works
BUFFALO, N. Y.

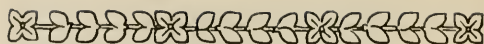

TRADE NOTES—(Continued)

three systems of lettering and for letters of any height. By turning the instrument, the bar can be used as an angle enabling one to draw guide lines at either 75° or 68°. Altogether it is a compact, convenient and practical instrument.

A BIG LITTLE LATHE

The Monarch Machine Tool Company, Sidney, Ohio, have recently perfected and added to their line two new lathes. The striking thing about them is that a man buying gets so much lathe in so small a space and at so low a price (as lathes go nowadays). They are not playthings, but real practical lathes. A number of new features embodied in the design and construction of the carriage, apron and head stock, make them especially fitted for school use. They are aptly described as "the biggest little lathes built." They are known as the Monarch Junior 9 and 11 inch.

COLORS FOR TOYS

"What colors are now available in convenient and inexpensive form for use in toy-making?" The answer to this question came to our attention the other day when we received from the American Crayon Co. of Sandusky, Ohio, a card showing samples of Tempera Colors. These colors are sold in small porcelain jars.

TRUCK HARDWARE

Shopwork teachers, particularly those in charge of wood shops, will be interested to learn that it is now possible to purchase the hardware for a factory truck. Complete truck hardware parts have recently been added to the line of woodworking machinery of the Oliver Machinery Company of Grand Rapids, Michigan. Many teachers prefer to build their truck body and purchase the hardware, which in this form can be secured on a low basis with an added saving on freight. The construction of a truck is an excellent project, and when completed serves a useful purpose. One or more of these trucks should be found in every school shop.

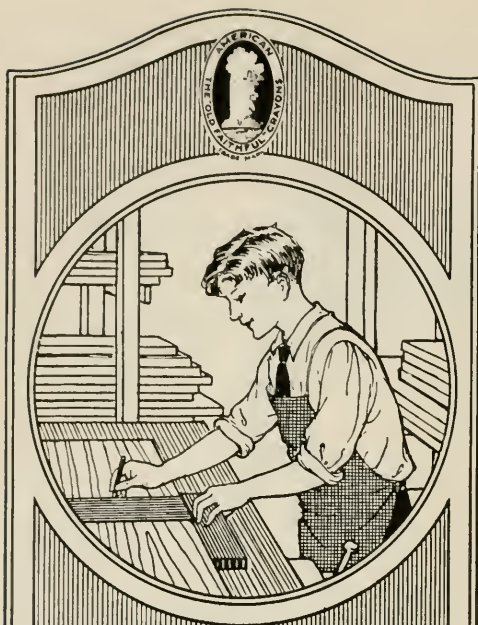

THE
"Old Faithful"
CRAYONS

Are ideal for
the purpose
of marking
upon paper
wood or metal

We have a special brand
for each purpose

THE
AMERICAN CRAYON
COMPANY

ESTABLISHED 1899
SANDUSKY, OHIO & NEW YORK

CABINET CLAMPS



Where Black Bros. Clamps are
known there is no Second Choice.

KNOW THEM

Send for bulletin today.

THE BLACK BROS. CO.
Mendota, Ill.



BOOK NOTES

IN THIS column in August, announcement was made of five new books that will be forthcoming from The Manual Arts Press during the next few months. These were *Art and Education in Woodturning* by W. W. Klenke, *Farm Mechanics* by Fred D. Crawshaw and E. W. Lehmann, *School Shop Installation and Maintenance* by Leon S. Greene, *Practical Electricity for Beginners* by George A. Willoughby, and *Chip-Carving* by Harris W. Moore. Another should be added to this list: *The Sewing Machine* by Miss Rosamond C. Cook.

Machine sewing has come to be such a permanent and important part of school instruction that both teachers and pupils have felt the need of a textbook which makes clear the fundamentals of sewing machine mechanism and gives the pupils a larger view of the possibilities in machine work in sewing. With this end in view the author's first aim has been to set forth in simple, clear, and not too technical English, and well illustrated with a few specially prepared diagrams, the different types of mechanism used in the various American machines. These types will be further illustrated by a great variety of line drawings and halftones representing all the standard American makes of sewing machine. Such illustrations go so far as to indicate, not only the various mechanical means employed to accomplish a given purpose, but also they illustrate the various attachments and unique features of the standard makes.

Miss Cook, the author of the book, has had a rich experience in practical sewing and dressmaking and has made an extensive study of sewing machines. She has taught this subject for ten years in the East and Middle West and her work is well recommended, not only by other teachers, but by sewing machine manufacturers as well.

At present Miss Cook is an associate professor in the Division of Home Economics in the Iowa State College of Agriculture and Mechanic Arts, at Ames, Iowa. Her special work is training teachers.

THE latest book issued by The Manual Arts Press is *Farm Blacksmithing* by John F. Friese. This is a very pleasing volume. It has clear and well-dimensioned working drawings, halftones of selected processes and of completed objects, brief, direct statements concerning procedure in the making of the objects shown in the drawings, and explanatory notes. The first part of the book deals with (a) tools for the farm blacksmith shop, (b) tools needed in schools, (c) description of the process of building a fire in a forge, and (d) a brief section on reading drawings. At the end of the book is a section on (e) iron and steel, one on (f) hardening and tempering, and a good index. The main part of the book

consists of (g) plates of working drawings with (h) illustrated notes on the making of the object represented. In these notes, however, the author has described in sufficient detail all the fundamental operations needed by the farmer-blacksmith, and has listed these near the beginning of the book and given references for each, so that one can quickly find the detailed description of any process, such as bending, heading, welding, hardening, etc. It will be seen that the book aims to give all the essentials of his subject in a very compact and convenient form.

IT IS surprising to notice what a large proportion of the questions that are asked concerning information on woodworking are answered in *Woodwork for Secondary Schools* by Griffith. For example, suppose the question concerns pattern making, Chapter IX presents the fundamental processes in a remarkably clear and comprehensive manner. If it is in reference to woodworking machinery, Chapter III is the best text available on the subject. If it is on wood-finishing, Chapter VII gives the essentials. If information is wanted on inlaying or wood-carving adapted to use in decorating school problems in woodworking, Chapter VI is the simplest and best treatment available. And if the question relates to standard processes in furniture construction, Chapter VIII gives the details that are most frequently wanted. While the book is essentially a textbook, and finds its chief use as such, it is also a valuable reference book for teachers. It treats of a great variety of subjects in a thoroughgoing manner.

THE following review of *Stenciling* by Adelaide Mickel, has appeared in *Architecture and Building*:

"This hand-book on the art of stenciling contains in simple form just the information needed in acquiring the technic of stenciling in several mediums upon various surfaces. Detailed descriptions are given of the materials and equipment used, of the process employed, together with many drawings and photographs of stenciled objects suitable for home and school work. It includes selected problems appropriate for the different grades in the elementary school and in the high school. It tells just how to proceed from the designing of simple stencils to the stenciling of elaborate designs in crayons and oil on such articles as table runners, window draperies, scarfs and other articles in a variety of materials. The author is connected with the department of Manual Arts at the Bradley Polytechnic Institute, Peoria, Ill. Her choice of illustrations adds to the attractiveness of the book and will prove very useful to the amateur interested in stencil work."



THE VERY BEST

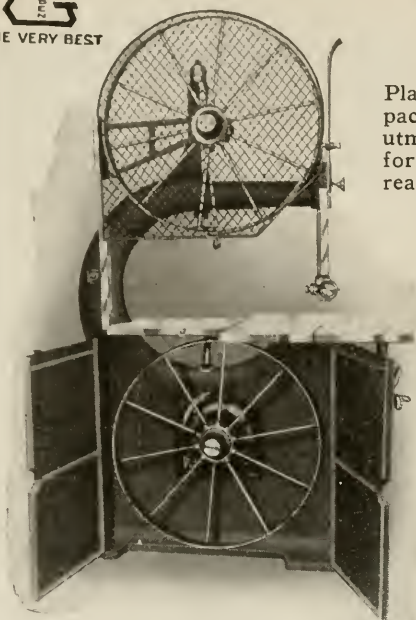

West Side

Plain, symmetric, a model of concise, compact design, a West Side band saw offers utmost capacity for good work. A machine for every purpose, each possessing very real advantages.

We would particularly direct attention to the uncommon strength of our band saws. They are of liberal proportions where the strain comes.

A New Motor Driven 36" Band Saw

—shown to the left. Most convenient of all to use. Its every adjustment is reached without change of position for the operator. Write us for information. Direct motor drives —belt drives—gear drives.

WEST SIDE IRON WORKS

Factory: Grand Rapids

General Offices:

1222 Washington Blvd., Chicago

IF YOU ARE IN THE MARKET FOR

LABORATORY FURNITURE

It will pay you to consult our engineering department. Its experience is at your service at no cost to you in planning, efficiently and economically, your laboratory requirements.



No. 9100

Standard or Built-to-Order Educational and Technical Furniture for Physics, Chemistry, Agriculture, Biology, Household Economics, and Manual Training.

SALES OFFICES:

806 Observatory Bldg., Des Moines	14 E. Jackson Blvd., Chicago, Ill.
514 Kemper Bldg. Kansas City, Mo.	1610 Bryan Street, Dallas, Tex.
1238 Newton Av. N., Minneapolis.	101 Market St., Harrisburg, Pa.
121 Chartres St., New Orleans, La.	Louisville, Kentucky.
48 Barrow St., New York City.	Otterbien, Indiana.
310 East Bridge St., Streator, Ill.	244 Third Street, Portland, Ore.

FACTORY: Manitowoc, Wisconsin

Mr. F. H. Wiese, President of this company and Supervisor of design and construction, is well qualified, through 25 years' experience in the field, to serve scientifically the needs of the student or of the mature scientist.

Wiese Laboratory Furniture has always stood for an unexcelled standard of quality, efficient service, and superior value.

Ask for our new catalog, No. 28

Wiese Laboratory Furniture Co.
Engineers and Builders



MANUAL TRAINING MAGAZINE

EDITORS CHARLES A. BENNETT, Peoria, Illinois.

WILLIAM T. BAWDEN, Assistant to Commissioner of Education, Washington, D. C.

ASSOCIATE ARTHUR D. DEAN, Professor of Vocational Education, Teachers College, New York City

EDITORS FRANK M. LEAVITT Associate Superintendent Public Schools, Pittsburgh, Pa.

WILLIAM E. ROBERTS, Supervisor of Manual Training, Public Schools, Cleveland, Ohio.

Business Manager L. L. SIMPSON.

Published monthly by The Manual Arts Press, 237 N. Monroe St. Peoria, Illinois.

Subscription Price, \$1.50; Canada, \$1.80; Foreign, \$2.00. Single Copies, 25 cents; Foreign, 30 cents.

Subscriptions, remittances, and manuscripts should be sent to THE MANUAL ARTS PRESS, Peoria, Illinois.

CONTENTS

ESTABLISHING A STATE PROGRAM OF PART-TIME EDUCATION.....	<i>K. G. Smith</i>	107
SHOP ORGANIZATION AND CARE OF SHOP EQUIPMENT (Illustrated).....	<i>De Witt Hunt</i>	110
LUMBER COST FIGURING FOR MANUAL TRAINING TEACHERS (With diagrams).....	<i>Edwin M. Love</i>	116
THE OLD WAY; THE PRESENT WAY; A BETTER WAY OF TEACHING ANY TRADE.....	<i>J. H. McCloskey</i>	119
EDITORIAL REVIEW FOR THE MONTH.....		122
A New Series of Monographs on Vocational Education—A Survey of Mechanical Drawing—Arthur Dean Accepts Appointment in Veteran's Bureau—Professor Jacobs goes to Santa Barbara—American Metalwork of the Eighteenth Century—Thomas Charles—A New Representative in the Southwest.		
A POINT OF VIEW.....	<i>Arthur Dean</i>	127
A Prophecy (a) Concerning Continuation Schools, (b) Junior High Schools, (c) Surveys, (d) Tests, (e) Vocational Guidance.		
WASHINGTON CORRESPONDENCE.....	<i>William T. Bawden</i>	130
Recent Educational Development in the Army—Reorganization of the Bureau of Education—Other Changes.		
IN FOREIGN COUNTRIES.....		133
London Lowers the Age Limit for Continuation Schools—The Effect of the War on Continuation Schools in Germany.		
PROJECTS, PROBLEMS AND NOTES.....		134
More Problems from St. Louis—Teaching Lettering—The Butcher Knife as a Forge Project.		
CURRENT PUBLICATIONS.....		142
FIELD NOTES.....		IV
California Field Notes—Manual Training at Wichita, Kansas—Around New York—From the Southwest—New England Items—Oklahoma Notes—Wisconsin Vocational Directors Meet—Vocational Conference Held—New Appointments—"Meet Me in Milwaukee"—Unique Plan for Financing a State School—Items of Progress.		
TRADE NOTES.....		XXXVI
BOOK NOTES.....		XLIII

This Magazine is kept for sale at McClurg's in Chicago, and Brentano's in New York.

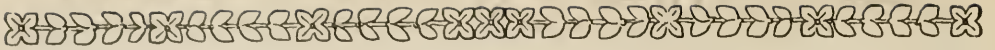

FIELD NOTES

CALIFORNIA FIELD NOTES

THE SCHOOLS of California are resuming work for the coming year in the field of manual and vocational training with renewed energy. During the summer, several hundred teachers of manual arts and trade work, and persons desirous of becoming teachers of these subjects, took courses in the summer sessions of the state teachers colleges and at the University of California both in Berkeley and at the Southern Branch in Los Angeles. The courses at the University were in charge of Charles L. Jacobs, and those of the Southern Branch were under the guidance of John Miller, who has been in charge of the trade and industrial teacher training work of the southern part of the state since Mr. Galbraith, the regular supervisor, took a leave of absence.

Among the teacher-training colleges, it is reported by Mr. Beswick, state supervisor of trade and industrial training, that the courses conducted at the teachers college at Santa Barbara were especially strong. Frank Horridge was in charge of the work and was strongly supported in his efforts by the president of the college, Mr. Phelps. President Phelps said in a letter recently, that the manual and vocational courses were very popular during the summer session and that he is very desirous of making them still more so. The fact is, President Phelps is determined to leave no stone unturned to make the manual and vocational courses at the Teachers College at Santa Barbara the best possible. The department for the training of teachers of hand work is to be enlarged to embrace the training of all varieties of manual, industrial, and trade teachers. Both regular term and summer session courses are to be offered in all branches.

CHARLES A. GLUNZ, who has been appointed in charge of manual training in the Union High School at Covelo, Mendocino County, is one of the newly elected teachers in California. This department will be a new feature in the Covelo High School. Mr. Glunz comes from the Philippine Islands where for over fourteen years he has been in charge of manual training at the Silliman Institute. His work was so successful there that the Institute held the position available to him for a year during which time, because of his desire to remain in California, Mr. Glunz was seeking an appointment here.

ANOTHER RECENT APPOINTEE is Henry W. Waltz, Jr., a printer, who is to take charge of the printing department of the newly created vocational branch

of the high school at San Jose. Mr. Waltz is not only a practical printer with a wide scope of practical experience in his field, he is also a recent college graduate. Something of the character of Mr. Waltz may be judged from the fact that he was president of his class during his senior year at the University of California.

JOHN KERCHEN GOES TO UNIVERSITY OF CALIFORNIA

Persons who are acquainted with the earlier activities in manual training in Portland, Oregon, will be interested to learn that John Kerchen, who some years ago was supervisor of manual training there, has recently been appointed by the University of California to take charge of a newly created department designed to bring the University into closer contact with the laboring people of the state, and help to make the University more serviceable to them. For this position, there can be no question but that Mr. Kerchen is eminently fitted. He has been a student of labor problems not only in theory, which he has for many years been studying, on and off, at the University of California, but also in practice, for he has worked as a carpenter for several years on buildings and in cabinet shops.

During the interim since his leaving Oregon, Mr. Kerchen has been for a year or more a full-time student at the University of California; and during the rest of the time up to last year, a part-time student, spending the remainder of his time as a teacher of manual arts, first in San Francisco and later in Oakland. Two years ago Mr. Kerchen was assigned to part-time education work at the Technical High School in Oakland, and last year he became director of part-time education in the city of Eureka, where it is reported, he has done most excellent work.

For over two years, Mr. Kerchen served as assistant in the work of training vocational teachers in evening courses at the University of California, and when the state embarked upon its plan of preparing teachers for part-time education by giving at various places in the state, intensive courses extending over fifteen lectures, Mr. Kerchen was one of the lecturers selected for this work.

IT IS TO BE REGRETTED that W. B. Hughson, one of the oldest manual training teachers in point of service in the Berkeley school department has taken a leave of absence to engage in other lines of work. Mr. Hughson is quite well known in the San Francisco Bay region, for he was connected at various times with the University of California as a teacher of manual training during the summer session.

WEST SIDE IRON WORKS

MANUFACTURERS—REMANUFACTURERS

Our Line

Composed of 14" Bench Band Saw, 36" and 42" Band Saw, 42" Band Rip Saw, No. 71 Rapid Cut-off Saw, No. 65 Straight Edger, No. 15 Self Feed Rip Saw and Variety Belt Sander represents the best machines on the market today. They have all stood the test of time; show the best of Workmanship, give the largest Productivity and stand for Durability.

We specialize in Re-manufacturing (not overhauling) all types and makes of woodworking machines; putting them in better shape than the original manufacturer.

Write us about our work; visit our show rooms in Chicago.

14-Inch Bench Band Saw

Shown on the right is our portable Band Saw. Can be had belt driven, belt driven by motor, gear driven by motor or direct motor driven.

Is equipped with switch and full equipment ready for you to fasten to any electric light socket and conveniently moved to any place in your shop. Everyone uses them. Our prices are exceptional for the tool you will receive. Write and let us give you more information regarding this little wonder.

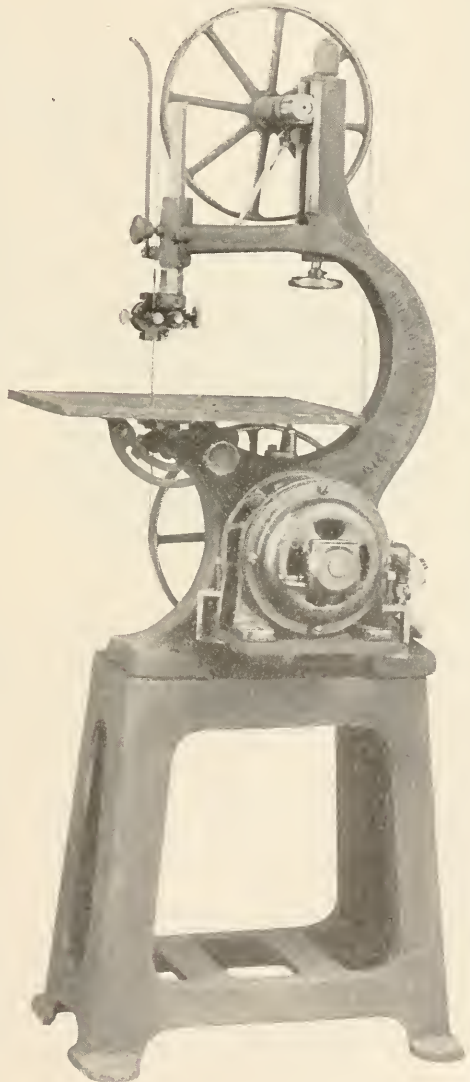

DIRECT MOTOR DRIVE

SALES DEPARTMENT AND CENTRAL REPRESENTATIVES

CHICAGO MACHINERY EXCHANGE

1222 Washington Blvd.

CHICAGO—MACHINERY MERCHANTS—GRAND RAPIDS



FIELD NOTES—(Continued)

RECENTLY the Department of Manual Arts of San Francisco has added to its staff, three new members: George Wallen, Palmer K. Sydes, and William Armstrong, all of whom have been for many years practical carpenters, and who, during the past two years, have taken teacher training in evening classes.

—CHARLES L. JACOBS.

PRODUCTIVE WORK IN PITTSBURGH

PITTSBURGH, Pennsylvania, has eight senior high schools, two junior high schools, one teacher-training school, four special schools and fifty elementary school centers—all equipped for industrial education. During the past school year the city employed thirty-eight shop drawing teachers in the high schools, one shop and drawing teacher in the training school, twelve shop teachers in the special schools and fifty-six shop and drawing teachers in the elementary schools.

The equipment in the schools varies; some of the high schools are equipped with draughting rooms, mill rooms, bench rooms, electrical shops, print shops, forge shops, and machine shops; others are fitted up for woodwork, mill-work and drafting. The elementary school centers have wood shops, drafting rooms and in some cases mill rooms.

A suggestion concerning the practical character of the work turned out from these shops is given in the following list: Hundreds of folding chairs, tents and tables with galvanized iron lining, fifty cafeteria stools, equipments for typewriting, and drafting rooms for a new high school building, vaporizing sprayers and sprinkling cans for the department of nature study and school gardens, ash cans, ash sifters, fire-proof stain cabinets, cooking utensils, and many small tools made in the machine shops, not to mention products of the printing and electrical shops.

The industrial education department of the schools of Pittsburgh is contributing much toward the material equipment and maintenance of the school system.

MANUAL TRAINING AT WICHITA, KANSAS

D. B. BADGER is beginning his second year as supervisor of manual training by completing the shop equipment in the third junior high school. The first two years of shopwork in the junior high school will be devoted to exploration courses. These courses will be similar to pre-vocational courses but they will teach usable shopwork related to home life. Only four to six different shop courses will be offered, some of these being

elective. The student will be allowed to choose the work he prefers in the last year of the junior high school.

In the senior high school, regular courses in manual training will be offered. Printing, woodwork, auto-mechanics, machine shop, and mechanical drawing courses are available. Besides these there are all day trade courses in auto-mechanics and machine shop.

Mr. Badger is in charge of the evening school program and during the past year organized classes in the following trades: carpentry, printing, janitor engineering, and mechanical drawing. Mr. Badger is taking every advantage offered by the Smith-Hughes program. He is doing great work in tying up the school with industry. His evening school courses are taught by men from the trades. During this year he expects to conduct a class in teacher training to prepare men and women to become teachers for the evening school classes. Mr. Badger attended the Conference on Vocational Education at Minneapolis, July 18—August 13 as a representative of the Kansas State Board for Vocational Education. He expects to utilize the school shop organization and plant to the fullest extent in forwarding a useful evening school program.

Mr. Badger, before coming to Wichita was teacher training director in the Kansas State Manual Training Normal, at Pittsburg.

AROUND NEW YORK

THEODORE W. LANGENBAHN has been appointed as teacher-in-charge of the new Bronx continuation school. His services began on Sept. 1, so that the preparatory work of organizing the new continuation school might be undertaken before the opening of the school term.

The Board of Education recently changed the name of the Textile School to *Textile High School* as the Board of Regents recognized the school as a technical school of secondary grade.

A six weeks course for the training of directors and supervisors of continuation schools was conducted by the State Department of Education at the College of Agriculture of Cornell University this summer. The experiment of giving such a course was fostered by Lewis A. Wilson, director of the division of extension education for the state. Seventy-five men and women who came from all parts of the state took the course.

One of the features which made the session of peculiar interest was the nature of the instruction. The work was not given solely by professors of theory, but by men and women who were actually



"Oliver" No. 127 Variety Belt Sander

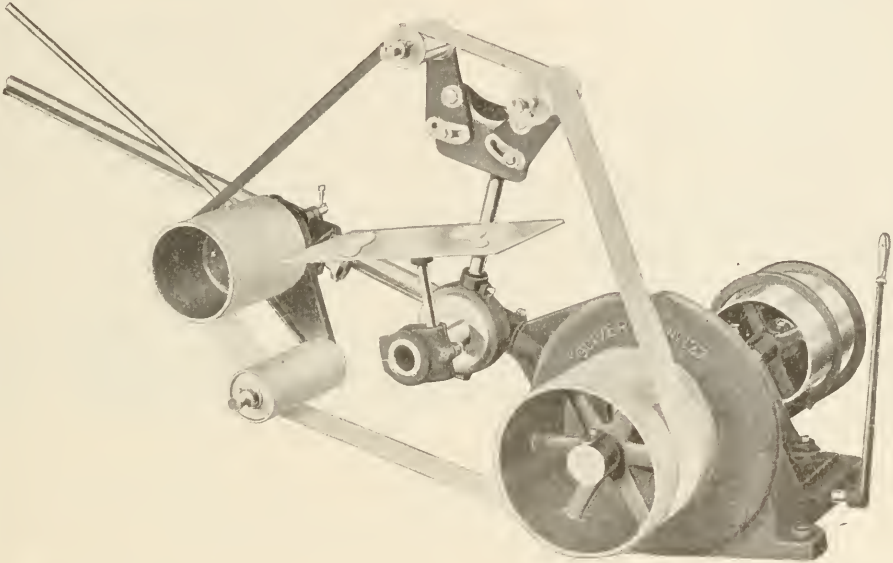

The Belt Sander here illustrated is a very useful machine. It adapts itself to a very wide variety of sanding and polishing jobs. The arrangement above illustrated shows how the machine is used for sanding brush-backs, hand mirror backs, oval picture frames, etc.; for different pieces other set-ups are used. Both convex and concave surfaces may be sanded.

The set-up shown below shows how flat work or such curved work as could be sanded on a disk sander is cared for.

Study your jobs and see if this machine wont work wonders for you.

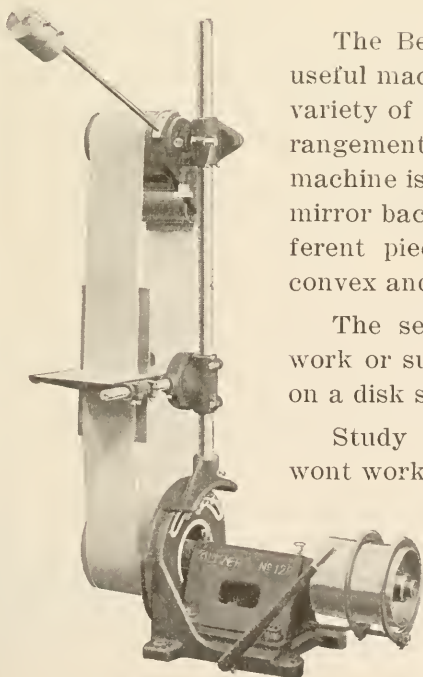

Oliver Machinery Co.
Grand Rapids, Michigan, U.S.A.

Branch Offices and Salesmen in principal cities



FIELD NOTES—(Continued)

at work in the continuation or industrial field or by state or federal agents who had spent the past year in surveying the continuation schools of the country by first-hand observation.

Robert H. Rodgers, specialist in industrial education, and Oakley Furney, specialist in part-time education, had visited every continuation and vocational school in the state, and so were able to give to the students in the course a knowledge of the best practice throughout the field. Harry B. Smith, special agent of the Federal Board for Vocational Education, who has visited continuation schools in all the twenty-three states of the Union where they have been established, was another speaker.

The problems which present themselves in the complex organization resultant from large numbers of pupils of various nationalities were presented to the directors and supervisors by Dr. Franklin J. Keller, principal of the East Side Continuation School, Manhattan. Dr. Keller gave a course in the administration and supervision of part-time schools. He also discussed the peculiar difficulties involved in getting young people into the right jobs in a course on vocational guidance and junior employment.

The staff of instructors also included Alfred E. Rejall, specialist in immigrant education for the State Department of Education, who conducted a normal class in the organization and administration of adult immigrant education.

Besides these men, by whom the training was carried on for the full six weeks, there came for periods ranging from one day to a week a number of men and women who had specialized in the various fields of vocational education. Dr. David Snedden, of Teachers' College, Columbia University, presented a picture of the modern continuation school as it may adapt itself to the needs of both the children and society at large. He held that such a school should offer to the pupil just what that boy or girl finds requisite for success in life whether be it an intensive course in spelling or in civil engineering.

Miss Isabel A. Ennis, assistant director for continuation schools in New York city, presented the problem of the method of teaching and also the necessity for making known to parents and employers the aims, purposes and success of the continuation schools. Dr. Gustave Straubenmuller, associate superintendent of schools, spoke on the adolescent boy.

Other speakers were Paul S. Lomax, specialist in commercial education, University of the State of

New York; Treva E. Kauffman, specialist in home-making education, University of the State of New York; Charles R. Allen, Isabel Craig Bacon, Mrs. Anne L. Burdick, and Layton S. Hawkins, of the Federal Board for Vocational Education; Owen D. Evans, assistant for continuation schools of the Pennsylvania State Department of Education; R. L. Cooley, director of continuation schools, Milwaukee, Wis.; Howard G. Burdge, New York State Military Training Commission, and Charles E. Finch, director of junior high schools and citizenship education, Rochester, N. Y.

—WM. H. DOOLEY.

NEW YORK STATE AWARDS INDUSTRIAL
TEACHERS' SCHOLARSHIPS

FRANK B. GILBERT, acting Commissioner of Education, has announced the award of twenty-five industrial teachers' scholarships provided for under Section 835 of the Education Law. These scholarships, valued at \$1,000 each, have been awarded to men who have had five years of successful experience in trade and technical occupations. The holders are required to spend one full year at the State Normal School, at Buffalo, preparing to teach their trade or technical occupation.

This year men were selected from the following trade and technical occupations: Machine shop work, printing, electrical work, automobile repairing, painting and decorating, mechanical drafting, architectural drafting, bricklaying, carpentry, and sheet metal work.

The winners of the scholarships are required to begin their course of instruction this fall.

FROM THE SOUTHWEST

A LARGE number of schools in Texas have entered enthusiastically into the Smith-Hughes work, both in the industrial and agricultural phases. Practically all of the larger towns and cities are doing Smith-Hughes work in some form or other.

For the last two years this work has been given at John Tarleton Agricultural College, which is a State School located at Stephenville, near the center of the state and close to the large oil fields. This school is a Junior College, giving two years of high school work and two years of standard College work. In order to comply with the law, requiring the work to be of High School rank, this work can only be given in the first two years. E. A. Funkhouser has been teaching trade carpentry in this school for the last two years in co-operation with Mr. Hunsdon, state director of industrial education.



“Folks Often Say—

“‘You never know people until you live with them.’ And it’s so with tools.

“For more than forty years we old-timers have been ‘living with’ Starrett Tools.

“We know them—know that underneath the polish there’s quality through and through.

“We’ve learned to know their dependable accuracy, and taught the youngsters to appreciate it, too.

“That’s why we say—‘Starrett!’ ”

Catalog No. 22 “EF” sent free upon request.

THE L. S. STARRETT COMPANY

The World’s Greatest Toolmakers

Manufacturers of Hack Saws Unexcelled

ATHOL, MASS.

Use Starrett Tools



42-2-6



FIELD NOTES—(Continued)

The first year the work was given, a modern five room bungalow was built on a lot near the College campus. The work was started in October and the house was ready to occupy the later part of February. The teacher furnished the lot and the building material, as the school authorities deemed it too much of an experiment to be willing to finance the undertaking. When the house was completed the results were so satisfactory that the next year a six room hospital of the bungalow type was constructed on the College campus.

The trade carpentry course is divided as follows:

Twelve and one-half hours of actual construction work is given each week, four hours of related drawing and two hours of related mathematics. The course runs for nine months and includes every problem entering into the building of a frame house. Besides the building of a house each year, considerable time is given to general repair work about the college. The value of this repair work amounts to hundreds of dollars each year. The related drawing enables the boy to draft plans for any ordinary building. The related mathematics enables him to figure bills of material and estimate the costs of various jobs.

The size of the class varies from eight to fourteen students. It is the opinion of the writer that the smaller number is more satisfactory for the best results than the larger number. Most of the boys who take the carpentry course have had one year of wood work or have been apprentices in the carpentry trade.

Several of the boys, after finishing the trade carpentry course, have gone out as foremen on small house jobs. A number have made enough money working at the trade during vacation and after school hours to continue their course through college.

—E. A. FUNKHOUSER.

NEW ENGLAND ITEMS

GEORGE C. GREENER, director of the North Bennet Street Industrial School, Boston, is enjoying a European trip, and a recent word from him at Madrid, Spain, indicates that he finds a great many interesting places and things.

FREDERICK P. COATES, printing instructor at the Sherwin Prevocational School, Boston, has resigned his position. Mr. Coates has proved to be an instructor of strong personality, excellent education and experience, and his loss will be keenly felt in his department of the Sherwin School.

REHABILITATION CLASSES for wounded ex-service men have been conducted during the summer at the

Boston Trade School, with Principal William C. Crawford as director, and Robert E. Baker as head instructor, assisted by a corps of ten other instructors. The Boston School Committee and other officials have been desirous from the beginning of this work to co-operate as far as possible with the Federal Government in this worth-while effort to afford a thoro training to the ex-service men, and the material results secured at this and other Boston institutions give ample evidence of the intensive and valuable nature of the instruction which is available for these men.

PALESTINE TO HAVE INDUSTRIAL EQUIPMENT

An interesting feature of the Zionist movement is the effort that is being made to provide for industrial instruction in Joppa, Palestine, and other centers of the Holy Land. The writer was recently asked to examine carefully a considerable number of woodworking machines embracing a wide variety, and these, together with a number of tractors and various agricultural machines and implements, have been sent to Palestine in charge of a man from Cambridge, Mass. who formerly conducted a furniture shop there.

This man will be a pioneer of a rather unusual type, inasmuch as to him falls the duty of transshipping these machines from their point of embarkation to the various centers where they are most needed, where he will have to erect necessary housing and install the machines. Those who are in charge of this part of the Zionist project have indicated that they plan first to manufacture their own mill and house timbering and finish, then manufacture furniture and finish to order. In the meantime it is their purpose to furnish also as complete industrial instruction to the workers of the various centers as their equipment will permit, both for educational and commercial purposes. It is expected that a considerable portion of the lumber needed for their purposes will be imported from Russia.

The entire plan is intensely interesting and the man who has this rather large instructional assignment will have the good wishes of the profession in his new venture, and it is equally certain that this proposition will be watched with much interest, especially as several of the centers now have no mechanical advantages for any type of construction or repair work.

BOSTON SCHOOL ACTIVITIES

Two centers for Summer Recreational Handicrafts have been maintained in the Boston District



Give this book to your boys

Teach them—

“HOW TO SELECT, USE
AND CARE FOR BITS”

We will send you as many as you need

The neat canvas roll is convenient and fits into the student's kit. Sets of six to thirteen bits from \$3 to \$7.



Encourage
orderliness
and care
of tools



The well made box for the boy's home work, or in the school, will inspire a love of good boring tools. **Special Christmas Boxes** at hardware stores. Sets of six to thirteen bits, \$3 to \$7.

Irwin Bits “Cut True—Clear Thru”
Perfection in manufacture does it

For 35 years the Irwin Solid Center Principle has been the standard of those who use wood boring tools. We invite correspondence from teachers who desire technical information for their classes.

The IRWIN AUGER BIT Co.

245
Grant
St.

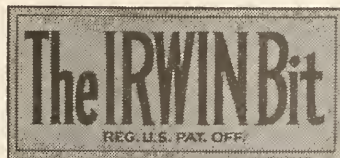

Wilmington
Delaware



FIELD NOTES—(Continued)

this summer, one in the Mary Hemenway District, Dorchester, and one in the Elihu Greenwood District, Hyde Park. The experiment has been very successful thus far, and it is expected that this work will be extended considerably as time goes on.

The pupils of Greater Boston are continuing their efforts in gardening, poultry raising, and preserving work, with most commendable results. Nearly fifteen thousand home and school gardens are being maintained in connection with the schools and homes of Boston alone, all being under the able direction of Daniel W. O'Brien, assistant director of the Department of Manual Arts, Boston School Committee. The work of the boys and girls has been prominently and generally featured in the public press and is continuing with almost as much interest as during the war period. Refugee furniture is also being made by public school and rehabilitation class students, at the request of the Red Cross authorities.

From present indications there will be a tremendous increase in the registration for grades VII to XII inclusive in the public schools this fall. Probably the increase in unemployment, together with the compulsory attendance regulations, is responsible for this condition. Boston has a great many employment bureaus and among the number is one conducted by the state. During the month of June there were on the average three thousand one hundred eighty applicants for work each day at this one bureau alone. A large percentage of these consisted of boys and girls who desired clerical positions, none of whom could be placed, while a small number was placed of those who were desirous of securing work in some type of industrial establishments, tho the number was of necessity quite small because of the prevalent business depression. The day of the abnormally inflated war wage has passed, and none appreciates the fact more thoroly than the young and inexperienced school pupil, who today is fortunate to secure employment of any type. One of the results of this increase of pupils is that much of the money available for general schoolhouse purposes will undoubtedly have to be used for needed housing, while matters pertaining to industrial equipment may not be expedited as hoped for until after the more pressing needs for buildings have been met. Plans have been made for the opening of several new shops in Boston schools and as soon as conditions will permit the necessary appointments of teachers will be made.

FRANK L. OGILVIE, one of the best sheet metal instructors in Boston, has left to go to Santa Monica, California, presumably in business for

himself. Mr. Ogilvie had charge of sheet metal work in the Tyler Street Prevocational School, Boston, which deals with a very cosmopolitan group of pupils. His success has been very marked, both with regard to discipline and to material results. He served in the United States Navy during the recent war as an instructor in coppersmithing on board certain of the navy vessels, and was given highest written commendation for his achievements with the men under his direction, as well as for his own craftsmanship. —FRANCIS L. BAIN.

WILLIAM T. STANTON, a graduate of Baylor University at Waco, Texas, and a master of arts from Brown University at Providence, has been secured to teach manual training at Moses-Brown School of Providence, Rhode Island. This is one of the oldest manual training departments in the United States, having been established in 1879.

OKLAHOMA NOTES

MARION E. FRANKLIN, formerly director of manual training in the El Reno High School, will be head of the manual training department in the Northeastern State Normal School at Tahlequah.

Mahlon C. Courtney succeeds W. W. Ford as supervisor of manual training in Chickasha. C. D. Wilson will have charge of the junior high school work.

G. A. Briggs, formerly at Hobart and Chickasha, is to have charge of all shopwork at the Cameron State School of Agriculture at Warner.

DeWitt Hunt, superintendent of shops at the A. & M. College at Stillwater attended the Conference on Vocational Education, conducted by the Federal Board for Vocational Education at Minneapolis, July 18 to August 13. Mr. Hunt will do some teacher training work for the State Board of Vocational Education during the coming year.

Russell Grow will teach manual training in the Jennings High School. The shop of this school has been closed for several years because of scarcity of teachers.

C. R. Faliot formerly ward school principal in McAlester has been promoted to director of manual training in the High School. The high school building burned in 1920, and a new building has been erected and a well equipped working shop has been opened.

H. K. McDowell is to be in charge of a new manual training shop in the Cherokee High School.

E. R. Hull is equipping and will have charge of the work in a new manual training shop in the high school at Moore.

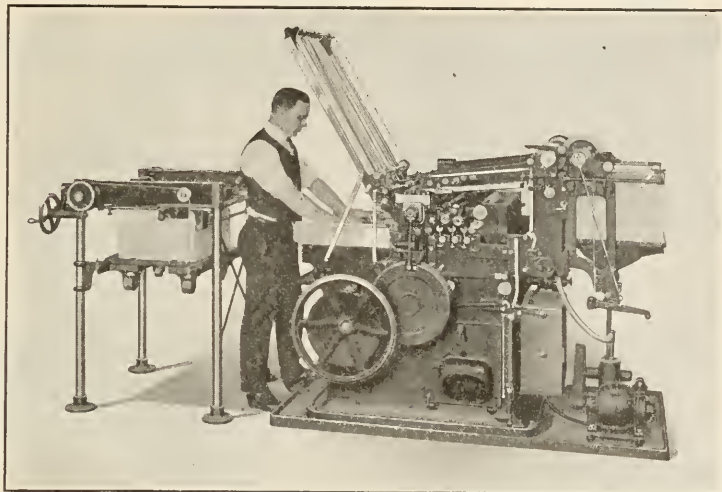

*The Kelly Automatic Press with Extension Delivery
(The Kelly Press is sold with or without Extension Delivery)*

Presswork

*on Kelly Automatic and Cylinder Presses is included
in the Advanced Printing Courses*

KELLY automatic and cylinder presswork is the next advanced step in the technical sequence of printing which comes after platen presswork. This advanced course permits of producing larger and more difficult pieces of printed matter, such as books and color printing.

Several leading technical high and vocational schools provide instruction on Kelly Presses, and the services of their graduates are in demand by commercial printshops.

Specimens of school printing done on Kelly Presses sent on request.

Write to-day.

F. K. PHILLIPS, *Manager*, EDUCATION DEPARTMENT

AMERICAN TYPE FOUNDERS COMPANY

JERSEY CITY, NEW JERSEY

BOSTON, MASS.
NEW YORK CITY
PHILADELPHIA, PA.
BALTIMORE, MD.
RICHMOND, VA.

BUFFALO, N. Y.
PITTSBURGH, PA.
CLEVELAND, OHIO
CINCINNATI, OHIO
ATLANTA, GA.

CHICAGO, ILL.
DETROIT, MICH.
ST. LOUIS, MO.
MILWAUKEE, WIS.
MINNEAPOLIS, MINN.

KANSAS CITY, MO.
DENVER, COLO.
PORTLAND, ORE.
SAN FRANCISCO, CAL.
SPOKANE, WASH.

LOS ANGELES, CAL.

WINNIPEG, CANADA





FIELD NOTES—(Continued)



The best in America—manufactured not for a "carpenter shop," but for a school teaching ideals as well as craftsmanship—yet sold at a fair and "competitive" price—that is Kewaunee.

Kewaunee

Manual Training Equipment

The Kewaunee Book will interest Educational Executives who are considering the installation of new manual training equipment. Illustrates and describes our complete line and explains our free planning service.

Write us at Kewaunee for your copy.

Kewaunee Mfg. Co.
LABORATORY FURNITURE EXPERTS

111 Lincoln St.

KEWAUNEE, WIS.

New York Office, 70 Fifth Avenue

BRANCH OFFICES:

- | | |
|-----------------|---------------|
| Chicago | Little Rock |
| Minneapolis | Denver |
| Phoenix | Houston |
| Kansas City | Spokane |
| Atlanta | Oklahoma City |
| Alexandria, La. | Jackson |
| Columbus | Los Angeles |
| Toronto, Can. | |



Manual Training Bench No. 1904
Has accommodations for three students.

W. S. Rosamond, instructor of auto mechanics, Drumright High School, attended the Conference on Vocational Education in Minneapolis as a representative of the State Board of Vocational Education. Mr. Rosamond will probably do some foreman training work in refineries around Drumright.

Charles W. Briles, state director of vocational education attended the Conference on Vocational Education in Minneapolis and specialized in foreman training. Mr. Briles, assisted by Mr. Cushman of the Federal Board and Mr. Quigley, district director have held one very successful foreman training conference in Tulsa. More of this work will be attempted in other centers during the coming year.

Auto-mechanics is increasing in popularity as a high school course. The high schools at Tonkawa and Shawnee have added this subject this year.

W. S. Coppedge, who taught in Davenport, Iowa last year, will be in Oklahoma City in the new Irving Junior High School shop this year.

G. E. Fisher, who has been instructor of manual training at Copan for four years, will have charge training at Copan for four years will have charge of manual training in the junior high school at Bartlesville. While at Copan, Mr. Fisher built two cottages of five and six rooms with his students—all outside of school hours. The cottages are used as teachers' homes. L. S. Con, formerly of Glenpool, succeeds Mr. Fisher at Copan.

Truman R. Lee, instructor of manual training at Wagoner for the past two years, has resigned to go into newspaper work.

Oklahoma City has installed printing in the Central High School this year. Three new junior high schools have been opened this fall. Each of these is equipped with rooms and equipment for shopwork and mechanical drawing. William Coppedge, Paul Bell, and Robt. B. Henry are new manual art teachers in these schools. A. R. Thompson, G. W. Brucher, A. W. Goffron, and Frank McKee, have been promoted to junior high school work. Ruth Taylor, and Erma Snyder are teaching manual arts in the grade shops.

Under the new plan adopted by the Ponca City schools of employing the teachers on a twelve-month basis, the manual training department is run the full year. In the summer the shops are converted into an actual factory where all furniture needed in the schools of the city for the ensuing year is made.

Much of the furniture for the coming year already has been completed under the supervision of Fred Heisler, the instructor, and a lot of it is in course of construction.

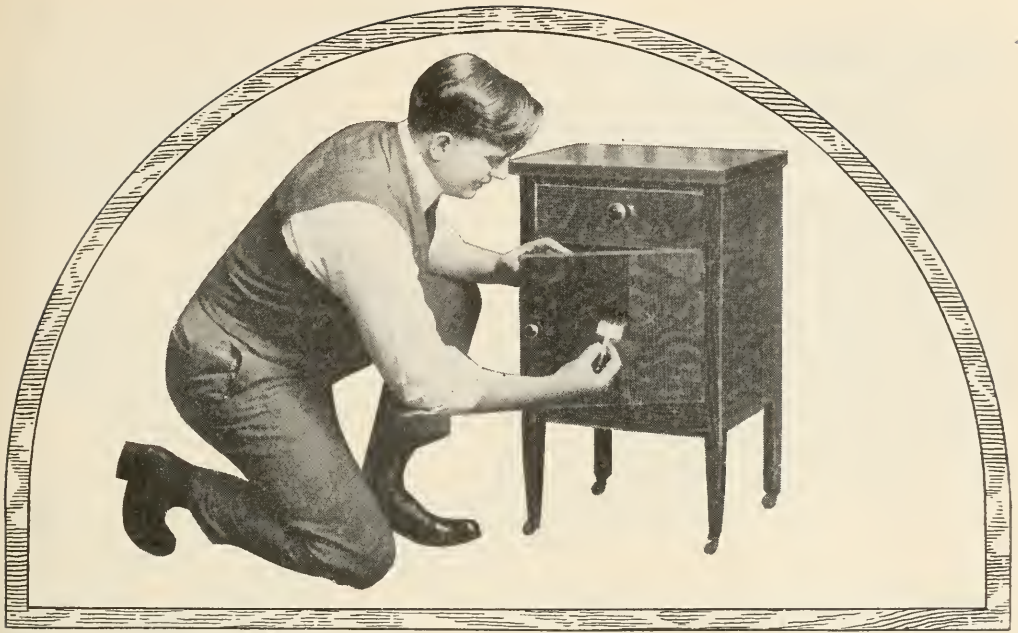

Finish It Well

THE finishing of manual training models is assuming more and more importance every year. Surely it is a subject which should be given its share of attention, for a beautiful model may be ruined if improperly finished, while the defects of a poorly constructed model are minimized if well finished.

JOHNSON'S ARTISTIC WOOD FINISHES

Johnson's Artistic Wood Finishes are now being used in nine-tenths of the schools in the Country. They are particularly adapted for manual training work as they may be applied by the youngest and most inexperienced pupils with the best results.

The Johnson Wood Finishes most popular among Manual Training Instructors and Pupils are Johnson's Wood Dye, Prepared Wax, Under-Lac, Paste Wood Filler, Flat Varnish, PerfectTone Under-Coat and PerfectTone Enamel. We have a very attractive exhibit of wood panels finished with these products which we are glad to send Manual Training Instructors who will give it wall space in their shop. Write for it.

Instruction Book on Wood Finishing Free

Write for our beautiful thirty-two page color book "The Proper Treatment for Floors, Wood-work and Furniture." It is full of valuable information for Manual Training Instructors and Pupils. It includes color card—gives covering capacities, etc. We will gladly send it free and postpaid for the name of your best dealer in paints.

S. C. JOHNSON & SON, Dept. M. T. O. Racine, Wis.
"The Wood Finishing Authorities"
Canadian Factory—Brantford



At Last— an adequate practice book on lettering

Think of the satisfaction of at last having an adequate method of practice in lettering.

That adequate method is presented in

French and Turnbull's Lessons in Lettering

Book One on Vertical Lettering is ready now. The price is 35 cents per copy—\$3.60 per dozen.

Book Two on Slant Lettering will be ready early in October.

Each of these books has 20 right hand pages which contain the ruling and copy, for practice, with the instructions on the opposite left hand page.

In Adopting This Series You Are

- 1—Getting a course arranged progressively—all or part of which may be used.
- 2—Getting the copy in the right place and of the right size.
- 3—Getting the most out of the student's time.
- 4—Getting a textbook which the student will keep.
- 5—Saving all the trouble of preparing instruction sheets.
- 6—Saving the student's time and trouble of drawing guide lines (the books are printed in two colors.)
- 7—Saving the cost of drawing paper.

A copy of Book One will be sent you absolutely without charge if you will fill in and mail coupon below.

FREE COUPON

McGraw-Hill Book Company, Inc.
370 Seventh Avenue, New York

You may send me, without charge, a copy of Book One of French and Turnbull's LESSONS IN LETTERING for examination with a view to adoption in my classes.

(Name).....

(Mem. of Teaching Staff of).....

(Address).....

M. T. M. 10-1-21

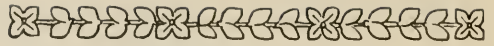

FIELD NOTES—(Continued)

WISCONSIN VOCATIONAL DIRECTORS MEET

A CONFERENCE of directors and teachers of vocational subjects in the state of Wisconsin was held at the Stout Institute, Menomonie, during the last week of August. Among the speakers at the various sessions were John Callahan, state superintendent of education; E. A. Fitzpatrick, secretary of the State Board for Vocational Education; Lieutenant Governor Cummings; Mrs. Glen Turner, of Madison; and a number of others.

Wisconsin has recently raised the age limit for compulsory continuation school attendance from sixteen to eighteen. Mr. Callahan predicted that there would be opposition to this law just as there was opposition in 1913 when the original law was enacted, but that it would melt away as it had at that time. Mr. Callahan made the significant statement that the vocational school should be every man's school from the age of fourteen to the end of his life.

Mr. Fitzpatrick made the statement, in one of his speeches, that "leadership in the continuation school is not going to be a job for a transformed manual training teacher. It is a job for a person sensitive to the new attitude in industrial relations with a high sense of the social opportunity of education, and a consecrated sense of duty; in the first place, to the boys and girls who are compelled to go to the continuation school, and secondly, to everybody in the community who feels the need for more education which is not met by the regularly established educational agencies."

Reports were made by Mr. Faulkes and Mr. Gunn, supervisors for vocational schools, on work in trade analysis which has been carried out with classes at the Stout Institute. The object of the analyses was to determine what processes are necessary in teaching certain trade work and in what order these processes should be taken up with the beginner in the trade.

VOCATIONAL CONFERENCE HELD

A NATIONAL conference on vocational education was conducted by the Federal Board for Vocational Education in Minneapolis July 18 to August 13. The conference, which was held at Dunwoody Institute, was attended by about one hundred people who came from practically all parts of the United States. Two general subjects were the topics of the entire conference, namely, teacher training, and foreman training. Three groups studied the former, while the membership of the

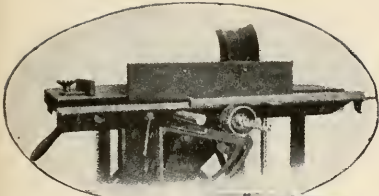

Jointer



Emery Wheel

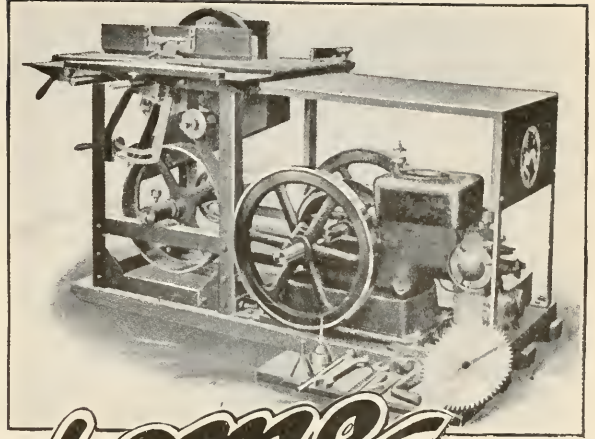

Ransome

Woodworking Mills

—formerly bought by supervisors of Manual Training Schools under the name of the “Berlin Woodworking Mill”—are mills that appeal to the real mechanic.

The main frame, made of heavy steel vertical angles, is firmly bolted to the machined semi-steel solid table top. The saw, not the table, is raised or lowered, instantaneously. With this construction, the main bearing is cast in a solid yoke, making it impossible for the bearing to get out of alignment.

A 3 H. P. Fairbanks Morse Kerosene Engine, noted for its economy and reliability, supplies the power. It is placed directly behind the table, where it is easily accessible.

Ransome Woodworking Mills are very complete. Twelve-inch rip and cross-cut saws are furnished with each mill. Other attachments include a jointer, boring attachment, disk sander, emery wheel, sticker head, mortising attachment, jig saw, wood lathe, and dado head—equipment to take care of any woodworking job that may come up.

Write for Ransome Bulletin No. 301

RANSOME CONCRETE MACHINERY CO.

1750 Second Street, Dunellen, N. J.

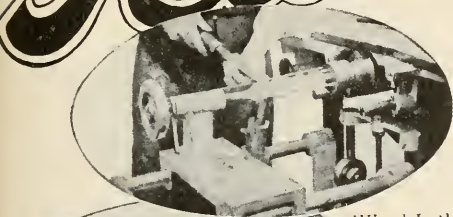

Wood Lathe

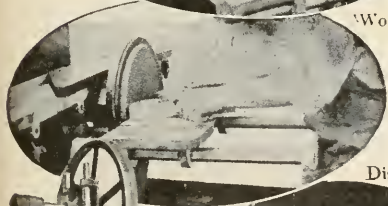

Disk Sander

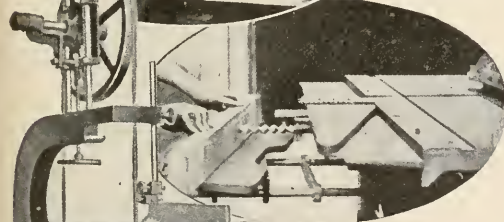

Boring Attachment

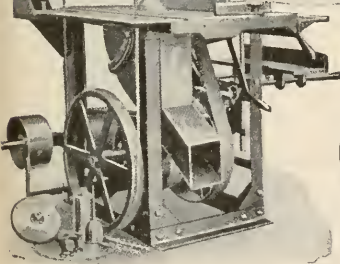

Band Saw



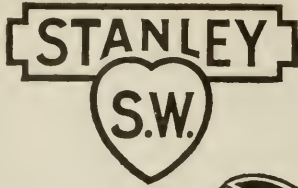

Blade,
Shank
and Head
One
Piece
of
Steel



STANLEY "Everlasting" Chisels

In all styles of "Everlasting" Chisels, the blade, the shank and the head are a single piece of solid steel—a patented feature which not only assures greater strength and durability, but also permits the transmission of the full force of a hammer blow to the cutting edge of the tool.

The leather washer placed between the upset head and the handle, acts as a cushion to prevent splitting. The brass ring driven into the handle, provides an additional safeguard.

Send for complete
tool catalog 15J

THE STANLEY RULE & LEVEL PLANT.
THE STANLEY WORKS
NEW BRITAIN, CONN. U.S.A.



FIELD NOTES—(Continued)

latter was divided into two groups. An intensive and valuable study was made of these subjects under the direction of the experts in vocational education who were conducting the classes.

The conference was under the general direction of J. C. Wright, Chief of the industrial education service. He was assisted by Chas. R. Allen, now director of educational service for the Chamber of Commerce, Niagara Falls; Frank Cushman, federal agent for industrial education, and other federal and state supervisors for vocational education.

NEW APPOINTMENTS

J. W. HOYER, who for the past three years has been director of mechanic arts in the Northern Normal and Industrial School, Aberdeen, South Dakota has accepted a position as supervisor of manual training and director of the vocational school at Casper, Wyoming.

Casper is located in the heart of the great oil fields of Wyoming and is one of the most important industrial centers of the Rocky Mountain region. The city has an extensive program of industrial education both in general and vocational subjects.

RALPH HERRING, who has been a teacher in the Vocational School of Bingham, Alabama, has resigned his position to take charge of the industrial arts course in Stockton, California.

ARTHUR CORAM, who is a graduate from the industrial art course at The Stout Institute, has been elected superintendent of schools at Forest River, North Dakota.

EARLE MYER, who has been instructing in the printing department of the vocational schools at South Bend, Indiana, has taken charge of the work in printing at Chisholm, Minnesota.

W. H. WHITMUS will be the director of manual training in the public schools of Cudahy, Wisconsin this year.

FRANK C. RIESS, and **Paul Knoop**, both graduates of The Stout Institute, are two of the new members of the corps of industrial arts teachers in Detroit.

MAYNARD W. LINGER is employed as a teacher of manual training in Grafton, West Virginia. Mr. Linger was a student at the West Virginia University this summer.

CHESTER MARTIN, who has taught academic branches in different schools in West Virginia, has made a special study of manual arts for the past year or two, and is now teaching woodwork and drawing in the schools of Lumberport.

S. L. EMSWELLER, who has been in attendance at West Virginia University since he returned from

Manual Training Magazine

OCTOBER, 1921

ESTABLISHING A STATE PROGRAM OF PART-TIME EDUCATION

K. G. SMITH

State Supervisor of Industrial Education, Lansing, Michigan

"AN HONEST confession is good for the soul" and incidentally I may add that a frank recognition of mistakes is necessary to educational progress, both for individuals and states. The state of Michigan has had rather a serious time with its part-time law, and it is possible that a discussion of our difficulties will be just as profitable as a statement of our achievements.

The Michigan part-time law went into effect the first of last September and required attendance for eight hours a week on the part of employed minors who had not reached the age of sixteen years prior to September 1, 1920. The upper age limit was set at eighteen years and the educational requirement for exemption from part-time school attendance at four years of high school work. The provision excusing from attendance all minors sixteen years of age and over on September 1, 1920, caused the law to go into effect gradually.

The difficulties met may be grouped under three heads: teachers and courses, co-operation of employers, enforcement of the law. We will take these up one at a time.

TEACHERS AND COURSES

Before the schools opened in the fall of 1920 very little had been done in preparing teachers for the work, due to the fact that it was very difficult to get teachers and school officials to undertake new work until they were obliged to. The effect of lack of preparation was

apparent as soon as schools opened in the fall. There were loud cries for help, both in organization and teaching. Where a district was fortunate enough to secure a man with some experience in part-time work, the work started and ran without much difficulty. By utilizing pamphlets, records and plans published in other states, supplemented with as much material as possible from the state office and the Department of Industrial Education of the University of Michigan, we managed gradually to get under way.

It soon became apparent that part-time education was not sold to the teachers themselves, to say nothing of employers. To meet this difficulty, ten lessons on part-time education were prepared in mimeograph form and given by the Department of Industrial Education of the University of Michigan as extension class work to the teachers in four representative cities outside of Detroit. These groups included not only part-time teachers but teachers in full-time schools as well. The definite lessons with assigned readings proved very successful, and interest in these classes continued to the end of the course. No attempt was made to formulate definite courses of study.

With subject-matter for teaching we had two difficulties: First, teachers did not, and often could not, connect up the classroom work with the experiences of the pupil. They could not see the part-time pupil as a special problem; he was

merely an unfortunate full-time pupil attending eight hours a week. Second, there was lack of proper shop equipment to make the work vocational. Eight hours a week in many cases had to be spent on academic subjects. This was not satisfactory. To remedy these difficulties we are planning as follows:

1. Courses in methods of teaching citizenship, hygiene, arithmetic and English were given by the University of Michigan at Detroit this summer for a period of four weeks. Courses in teaching related subjects were given at the same time. These were intensive courses with two-hour recitation period four days a week.

2. We are urging the equipment of shops for vocational work for part-time pupils. Furthermore, our part-time law provides that four of the eight hours may be utilized for "instruction under working conditions; provided such instruction meets the approval of the superintendent of schools and the State Board for Vocational Education."

We hope by this means to work out some effective instruction "on the job." The writer believes that supervised employment and instruction under shop conditions is going to be an important development in the education of part-time pupils from sixteen to eighteen years of age. In no other way can our smaller cities make their instruction vocational except in a very limited number of occupations. It is a new and untried field but seems to offer possibilities.

CO-OPERATION OF EMPLOYERS

The co-operation of employers has not been so hard to secure as we expected. This is possibly due to the fact that industrial depression materially lessened the number of juvenile employees. One thing, however, occurred which always happens when a part-time law goes into effect for the first time: namely, employers in some cases refused to employ boys and

girls who were required to attend part-time school. This was viewed with complacency by some school men, because they said "this will tend to force boys and girls back into the full-time school." This indicates a failure to comprehend the problem fully. It is not the function of a part-time school to force boys and girls back into the full-time school, that may be one result of it. The essence of part-time school instruction is *work and school*. If employers refuse to employ those subject to the provisions of a part-time law, then a part-time program fails in its usefulness. It is our plan to promote part-time education vigorously this year among employers, and sell this type of education to them as well as to teachers and parents. It should be said, however, that a number of cities of the state have reported one hundred per cent co-operation on the part of their employers, and the main difficulties experienced have been in securing teachers and not in co-operating with the employers.

ENFORCEMENT

A part-time law which cannot be enforced is a failure. It is the writer's feeling that a law which has a rather low educational and age limit and is strictly enforceable within those limits is better than one with high age and educational requirements and not so strictly enforceable. It is his feeling also, judging from past experience, that it is unwise to begin by placing a high age limit and educational requirement. It is better to begin farther down the scale and as experience is gained to work up to the higher limits.

In our Michigan law one great defect in the provision for enforcement was at once apparent. The only penalty provided for non-attendance on the part of the pupil was revocation of permit. Naturally if a boy or girl was not working the revocation of a permit was entirely

ineffective. Another defect also became apparent, tho more gradually. There was no penalty provided on the parent for failure to send a boy to school, and according to the ruling of the courts, if a parent did not wish his boy to attend school the boy could not be considered a truant. As stated above, most employers co-operated heartily with the school authorities in sending the boys and girls to school, and in many cases it would have been impossible to secure attendance on the part of the pupils if employers had not insisted on the attendance of employees subject to the law.

Our law provides no penalty on a district which fails to establish a part-time school when required to do so. We have not yet had sufficient experience to enable us to judge whether this is necessary.

AMENDMENTS MADE THIS YEAR

Early in the session of the legislature it became apparent than an effort would be made to repeal the part-time education law entirely. Just what influences were back of this it is not necessary to state. Suffice it to say that an exceedingly strong effort was made to repeal the law and it came very near succeeding. It was defeated by strong, united action on the part of progressive superintendents, school boards, social workers and employers. The writer feels that the high age limit, the high educational requirement and weak provisions for enforcement were responsible, at least in part, for the dissatisfaction with the law. There seemed to be a feeling that it would be practically impossible to keep boys and girls in part-time school up to the age of eighteen years and give them effective instruction. Objection was made on the ground of expense and also on the ground that proper vocational instruction could not be given to pupils sixteen and eighteen years of age in the regular

public schools. Altho the attempt to repeal the law failed in the regular session of the legislature it was brought up again in the special session and it required vigorous efforts to prevent very undesirable amendments from being made. The desire seemed to be to remove all of the mandatory provisions. A compromise was effected, however, and the present law has an upper age limit of seventeen years instead of eighteen and an educational requirement of two years of high school instead of four. The provisions for enforcement have been greatly strengthened and the law is now on practically the same basis as our compulsory education law, which has been in operation since 1905. As stated above, a provision has been made for utilizing four of the eight required hours of instruction per week for shop instruction given under working conditions.

Another amendment, not so desirable, gives the local school board the power to determine the hours of session which may best suit the local conditions and school administration. No state and federal aid will be given to any school which does not conduct its classes during the working hours, and school authorities do not contemplate substituting night classes for daytime classes.

CONCLUSIONS DRAWN FROM OUR EXPERIENCE WITH PART-TIME EDUCATION

1. It is better in establishing a state system of part-time education to set a low age limit and low educational requirement and to make the law strictly enforceable within these limits.

2. Before a part-time education law is put into effect, definite plans should be made for the training of teachers, extending over a period of at least one year before the law goes into operation. These plans should include extension courses in industrial centers as well as resident courses in teacher training institutions.

3. Definite effort should be made to acquaint employers with the provisions of the law and with the advantages of part-time education; "no school, no job" should be their motto.

4. Extension courses should be conducted for part-time teachers in service, and teachers of full-time public school classes should be encouraged to take these courses in order that they may be more fully in sympathy with the part-time program.

5. Part-time education at the present time needs to be sold to the school authorities just as much as to the employers and in some cases it is more difficult to sell it to school authorities than to employers.

6. A part-time education program should not be looked upon simply as a means of keeping a boy in school. This is not, in itself, a justifiable end. Work

and school are the essential features of a part-time program, and if the only effect of a part-time law is to send boys and girls back to full-time schools, it fails as a means of real vocational education and as a means of vitalized general education.

7. The centralized part-time school conducted by specially trained teachers who supervise and follow up their pupils is the most promising solution of the difficulties and evils of juvenile employment.

8. Many boys and girls make better progress and are better satisfied in a part-time school than in a full-time school. This is no reflection on the full-time school, but simply recognizes differences in pupils and affords another means of education which should be welcomed by all progressive educators.

SHOP ORGANIZATION AND CARE OF SHOP EQUIPMENT

(Continued from September Number)

DEWITT HUNT, Director, Shop Practice, Oklahoma Agricultural and Mechanical College, Stillwater, Okla.

CLAMPS

THE method of storing clamps shown in Fig. 5 classifies handscrews by size and affords a means of storing a good many clamps in a small space. The iron clamps are stacked on projecting 2 x 4's and this rack will hold twelve long and twelve short clamps. These clamp racks are fastened to a wooden partition wall. A clamp rack similar to the lumber rack shown in Fig. 4 (page 84 in September number) may be made to stand on the floor, thus avoiding the necessity of fastening it to the wall. This is recommended where all walls are brick or plaster. Many clamp racks are designed so that handscrews must be clamped on the rack. This makes extra work. The rack shown in Fig. 5, will hold wood clamps open or nearly closed.

All clamps require frequent oiling.

The screw wears more quickly and is very hard to operate when dry. Oiling the face of jaws of wooden clamps will prevent glue from adhering.

At certain times of the year, all of the clamps in the shop will be used during the day and, in most cases, will be left on work over night. A good teacher will remove all clamps when he reaches the shop each morning; otherwise, the first student who needs clamps will attempt to remove them and may scar or break the work.

BRUSHES

Fig. 6 shows a method of keeping brushes. Each compartment holds a brush for a particular stain or varnish. The top of a rectangular quart stain can is cut off and the can set in the bottom of the compartment. A 3-16" hole is drilled in the handle of each brush and a 6-

penny finishing nail projects thru the side of the case. The brush is thus hung up on the nail; each can contains the proper liquid in which the brush should be suspended in order to keep it soft and pliable. Some of the brushes with their use and the liquid in which they are suspended are:

the student from using the brush without consulting the teacher. Two brushes are kept in some compartments, particularly white shellac and varnish.

HANDSAWS

It is much better to keep saws in a saw case, such as that shown in Fig. 7, than to hang them on nails.

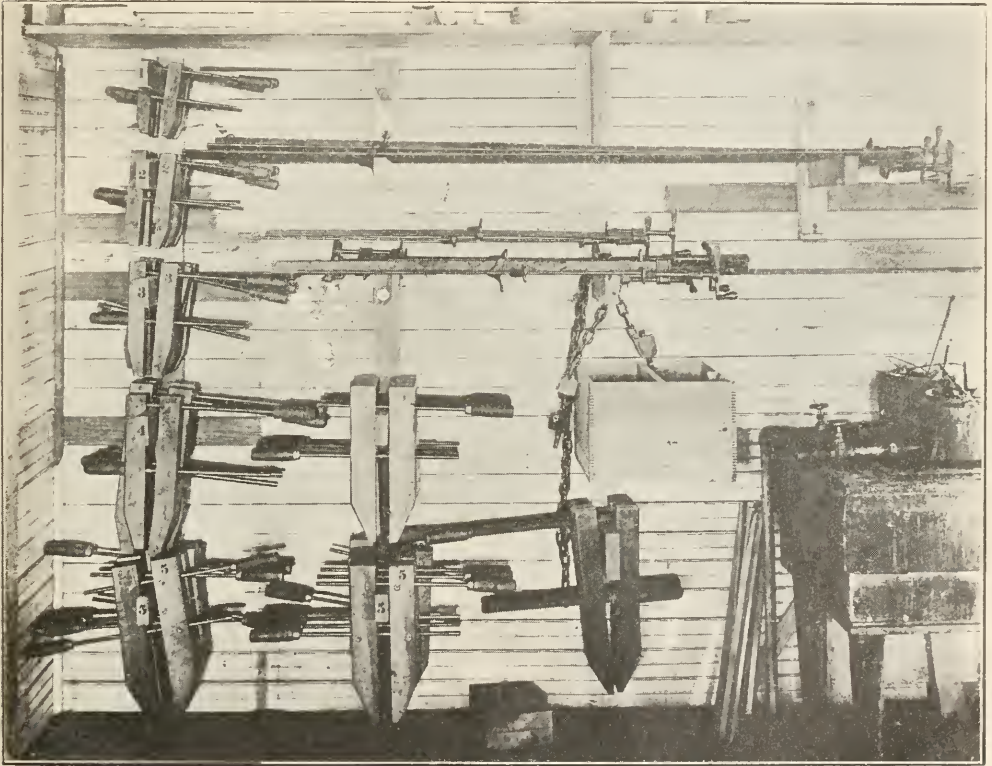

FIG. 5. RACK FOR CLAMPS

- White shellac brush—alcohol
- Orange shellac brush—alcohol
- Spirit stain brush—alcohol or benzine
- Oil stain brush—turpentine
- Paste filler brush—linseed oil
- Varnish brush—turpentine

A card, giving use and care of the brush and name of liquid in which the brush will be kept soft is tacked on the under side of the lid of the box. The box has a hasp and is kept locked, thus preventing

This rack typifies a practical solution of a problem in design. The saw should be protected when not in use; the rack should hold several saws; the rip-saws should be grouped apart from crosscut-saws and the whole rack should be pleasing in appearance. All of the handsaws in the shop may be kept here. The saw rack should be near the lumber rack.

GENERAL TOOLS

In this group of tools may be placed braces, draw-knives, spokeshaves, auger

bits, countersinks, screw-driver bits, bevel squares, etc., tools which must be available but are not placed at each bench. There are two ways of keeping them: one where a locked store-room or cabinet is available, the other where these tools are placed on a tool panel and are accessible to all students. The tool-room and check system is probably necessary in

be sufficient for ordinary-sized classes. By this device two things may be accomplished: (1) the student breaking a drill will be easily detected; (2) each student will necessarily have to ask for a drill by size.

SPECIAL TOOLS

The following special tools, many of which are expensive, should always be



FIG. 6. BOX FOR BRUSHES

some machine shops and industrial plants but is hardly practicable in the manual training shop. If the panel tool rack is made with a place for every tool in such a way that no tool can be misplaced and the whole rack is easily visible from the instructor's place as he checks the class out of the room, the teacher should be able to keep close check on all tools. One exception to this statement is the case of drill bits. Perhaps the best way to take care of drill bits is for the instructor to carry them in his apron pocket. It is quite possible to plan the woodwork course so that about four sizes of drills are sufficient, that is, 3-32", 4-32", 5-32", and 6-32"; two drills of each of these sizes will not over-burden the teacher and will

kept under lock and key and used only when the instructor advises and allows:

Yankee drills	Expansive bits
Routers	Pliers
Doweling jigs	Depth gages
Mortising gages	Universal planes
Glass cutters	Trammel points,
	etc.

A great deal of time is saved for the instructor if all locks in the shop can be opened by a master key. If the locks on individual drawers in benches are operated by a master key, additional locks of this series may be bought and used on lockers around the shop.

CARE OF NOTE-BOOKS

It is well to have a filing case, like that shown in Fig. 8, in which the students

can file their notebooks. In this way the teacher can refer to the books when he wishes.

BLUEPRINTS, BOOKS, ETC.

Blueprints of models, books on woodwork and furniture design, and furniture catalogs are necessary for operating the manual training shop successfully. It is no loss to a furniture manufacturing company to have their catalog in the manual training shop. Good design, good workmanship, honest construction—these things are taught to the boys of today so that they will be able to select furniture having these qualities. The reference

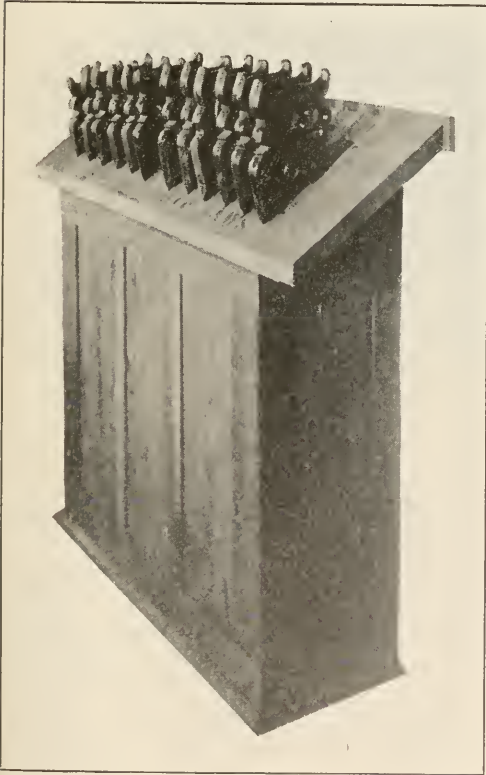

FIG. 7. HAND SAW RACK

books are often furnished by school boards, but where this is not so the manual training teacher must bring out his own books. He should not feel badly

about this, for does not the carpenter furnish a big chest of tools? The machinist often uses his own chest of tools. These books, blueprints, etc., are but the

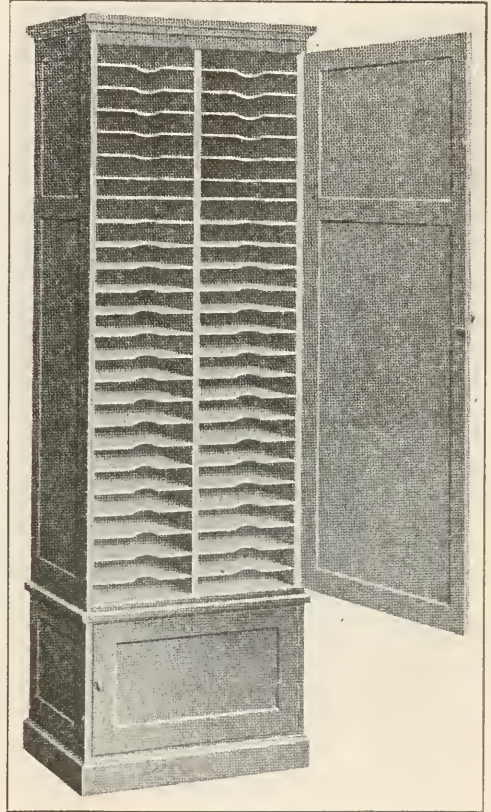

FIG. 8. GRAND RAPIDS FILING CASE

tools of the manual training teacher's business. They are of little service to him when not used. So books, magazines and catalogs should be on the teacher's desk where the boy may at least see them. Blueprints should be stored in drawers, and arranged in each drawer by groups; that is, nail construction, dado construction, screw construction, etc. For the ordinary two-year course in hand woodwork ten or more filing drawers will be necessary and an up-to-the-minute teacher will have a hundred or more blueprints available.

PANELS, PICTURES, EXHIBITS

It is very helpful to have the shop walls decorated with framed pictures, panels, etc., containing examples of work or kinds of supplies. Many companies send to teachers, on request, charts well worth carefully framing and preserving. Charts

photographs of work is delightful, and a suggestion is made in Fig. 9 which shows a shop-made photograph rack.

SCREWS

Many teachers find it necessary to keep screws, nails and other supplies locked up at all times. A cabinet for screws



FIG. 9. EXHIBIT CASE FOR PHOTOGRAPHS OF WORK

may be obtained showing full section of jack-plane with names of all parts, hand-saw teeth showing cutting action, files and their names and uses, and many others. Most of these should be framed behind glass so that they may be preserved. Exhibit boards showing different kinds and sizes of screws, nails, cabinet hardware, pattern-making hardware, etc., are worth all the time necessary for making them. It is well to have a table of sizes of screws close to the screw cabinet and one showing sizes and kinds of nails near the nail cabinet. Permanent exhibits are difficult to keep up. An exhibit of

composed of about fifteen small drawers to hold one or two gross of screws, located in a convenient position in the shop, is a great help. A card holder on each drawer should receive the top of the box in which the screws come. The drawers should contain the following screws: $\frac{1}{2}$ " No. 5, flathead bright; $\frac{3}{4}$ " No. 7, same; $\frac{3}{4}$ " No. 9, same; 1" No. 7, same; 1" No. 9, same; $1\frac{1}{4}$ " No. 10, same; $1\frac{1}{2}$ " No. 10, same; $1\frac{3}{4}$ " No. 10, same; 2" same, and $2\frac{1}{2}$ " same; $\frac{3}{4}$ " No. 7, round head; 1" No. 7, same; 1" No. 9, same; $1\frac{1}{4}$ " No. 10, same; $1\frac{1}{2}$ " No. 10, same; 2" No. 10, same. When a student needs screws he will have

to select them from this assortment. It is possible that in some shops this case cannot be left in an open part of the shop because of thievery, but ordinarily, keeping only one gross of screws in each drawer, and the reserve stock locked up, this plan is feasible.

NAILS

Nails may be kept in a cabinet similar to that suggested for screws. On all drawer fronts should be printed carefully the full standard description, for example: 8d common, 6d box, etc.

FINISH MATERIAL

The manual training teacher should be able to make up common oil stains and fillers, and he must keep on hand the necessary materials. A good plan is to keep a 5-gallon can for storing each of the following: linseed oil, turpentine, alcohol, and benzine or benzol. These four liquids are used very frequently in the finishing room. With them must be kept colors ground in oil, dry colors, asphaltum, varnish, shellac, silex, pumice, lampblack, etc., in suitable containers. Special stains should be bought as needed.

ABRASIVES

Sandpaper and steel wool, if used, should be kept under lock and key, except a small quantity carried in the instructor's apron pocket. No student should be given sandpaper except when instructor has ascertained to his entire satisfaction that work is ready to be sanded. Sandpaper of grades $\frac{1}{2}$, 0, and 00 is enough for the ordinary shops and one grade of steel wool, No. 1, is sufficient.

OILSTONES

Oilstones should be in some sort of holder and may be hung on the wall or fastened down in various convenient places around the shop. Fig. 10 shows an oilstone holder now being made in the foundry for use in the writer's wood shop. The oilstone is fastened in the holder by means of two headless set screws and

will be fastened down on shelves over two radiators near the bench section of the shop.

STEEL SQUARES

This tool is very useful for any kind of woodwork and it is well to have one at each desk. It is not hard to design some sort of rack or place for it at each desk.

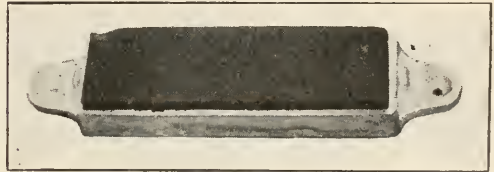

FIG. 10. OILSTONE CASE

BENCH TOOLS

The least number of tools at each bench is probably the best slogan. As few as ten tools will be sufficient in most shops; these are: (1) jack-plane, (2) block-plane; (3) one-foot rule; (4) screwdriver; (5) gage; (6) try-square; (7) back-saw, 12"; (8) 1" chisel; (9) $\frac{1}{4}$ " chisel; (10) steel square. It is possible to have all these tools visible on the top of the desk. It is also possible to keep all of these tools, except the steel square, in one of the drawers of the 8-drawer type of bench.

Finally, the manual training teacher must see that his shop is properly organized and must do this type of work himself. Few students will be able to make tool racks to please the careful teacher. No good teacher should be satisfied for very long with inadequate methods of caring for his tools or supplies. This means a great deal of hard work and faithful attention to duty. When a teacher moves every year, he can hardly have the ambition necessary to organize a shop. A teacher must stay with one shop for several years before he should be able to say "I am satisfied with my shop. All of the equipment I have is cared for properly." When this sort of teacher does

stay with his job until he can make this statement, the job usually grows with him and about that time he is given more equipment to plan for, to study and to provide for. The ambitious teacher is

happy when he has these problems to study and master. Happy is the man who feels that he has a mission and who is earnestly attempting to do his share of the work of the world

LUMBER COST FIGURING FOR MANUAL TRAINING TEACHERS

EDWIN M. LOVE

Formerly Instructor in Elementary and Junior High Schools, Granite District, Utah

NOT the least of problems encountered by shop teachers is the checking out of lumber and correction of prices figured by the students. Whether the pupils buy the lumber from school sup-

ply and to make a separate calculation in each case is manifestly impossible.

Many teachers prepare tables that show at a glance the cost of any given piece of work. Where many kinds of

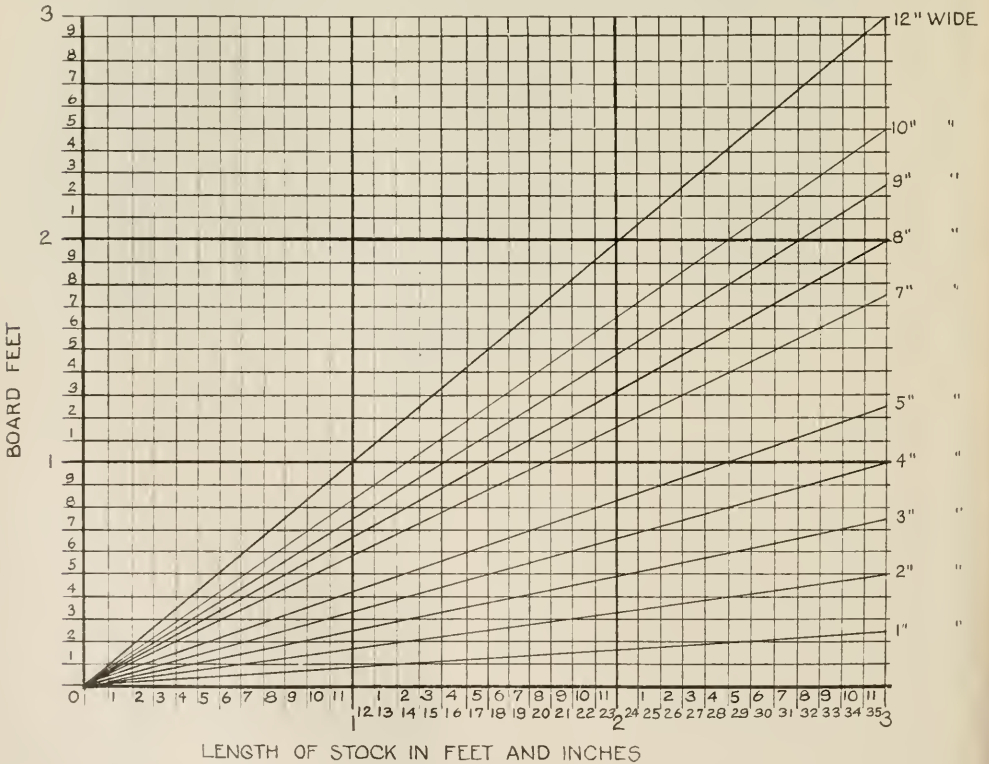

LENGTH OF STOCK IN FEET AND INCHES

FIG. 1

plies or receive it gratis, an accurate account of all materials used must be kept. This means that, even tho scores of pieces of lumber may be issued daily, a record of the sale must be made at the

materials are used the preparation of such tables consumes a great deal of time, and often they are made obsolete by a change in lumber prices.

An algebraic graph offers a simple

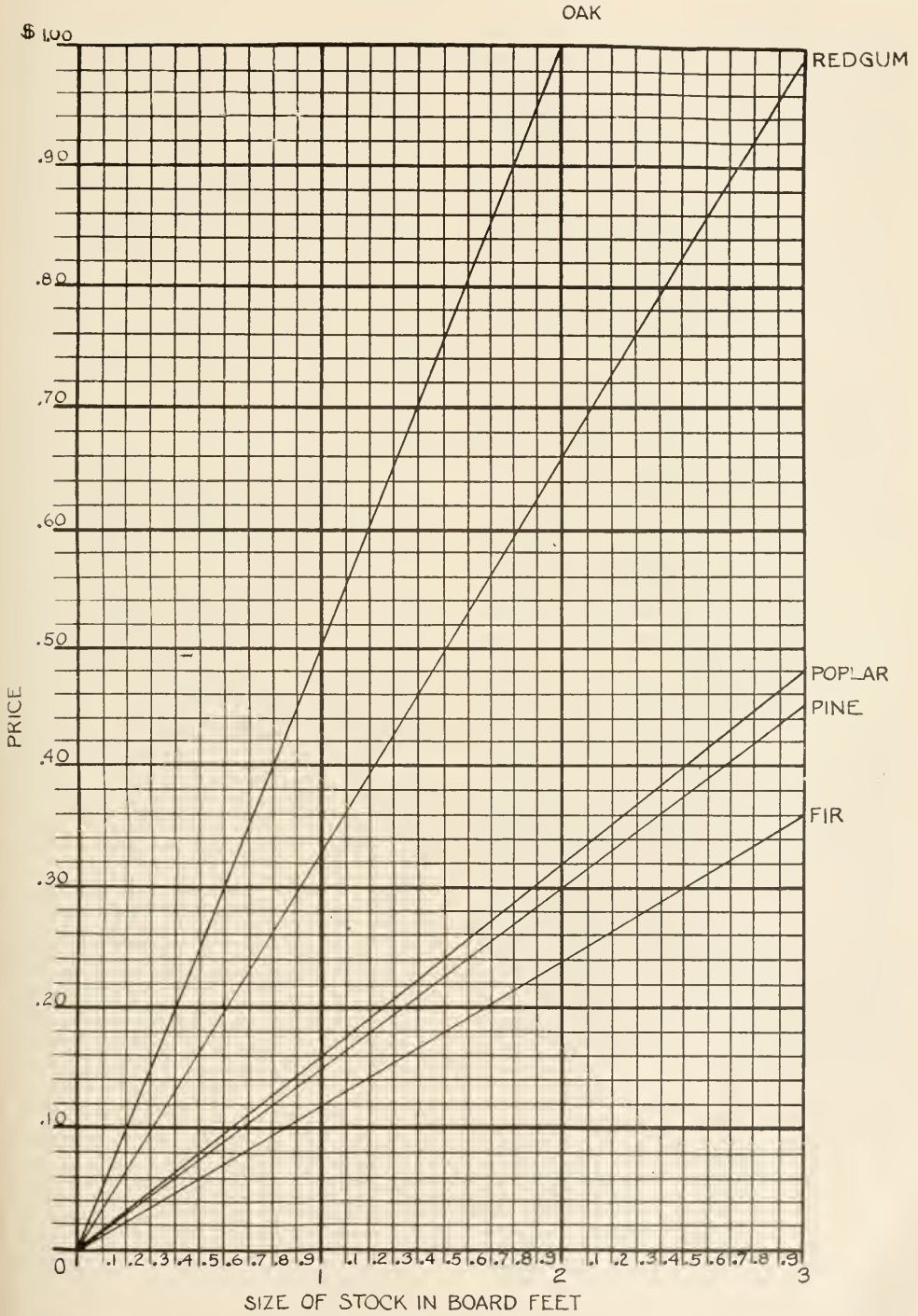

FIG. 2

method of constructing such reference tables. Since the number of board feet in any board of uniform width varies directly with the length, it follows that the graph of the equation is a straight line.

Fig. 1 illustrates the graphical method of measuring board feet. On a sheet of graph paper lay off a base line, choose a suitable number of squares as a unit, and point off 36 units, as illustrated. These graduations represent length of a board in inches. Next choose units for the vertical scale, and point off three groups of 10 each, to stand for tenths of board feet. Now if a straight line be drawn from the zero point to the intersection of the vertical line numbered 36 inches and the horizontal line numbered 3 board feet, all possible values for board measure of stock 1 inch thick by 12 inches in width are represented. To check the accuracy of this we need only make test readings. Thus, a board 1 inch thick, 12 inches wide and 12 inches long contains 1 board foot. By consulting the graph we find that the oblique line intersects with the vertical line opposite 12 inches at the point of intersection of the latter with the horizontal line reading 1 board foot. The graph for 8-inch stock is a line drawn from zero point to the intersection of the 36-inch line and the 2-board feet line. In the same manner, by determining the value for a 3 foot

length of any width of board, its graph can be constructed.

A little practice in reading the graph will enable the instructor to make readings very rapidly. Suppose that a boy buys a piece of stock 7 inches wide and 33 inches long. The oblique line marked 7 inches intersects with the vertical line marked 33 inches near the intersection of the 33-inch line with that reading 1.6 board feet. If thicker stock is to be measured, multiply the reading by the proper constant.

Fig. 2 illustrates the price chart which is used in connection with the board measure graph. In this case the units for tenths of board feet are laid out on the horizontal base line, while the vertical scale reads in cents. Oak is here figured at 50c per board foot, and a line connecting zero point with the intersection of the line marked 2 feet and that marked \$1.00 determines prices on oak to the nearest cent. By means of interpolation units of less than a tenth of a board foot may be read. A separate line for each variety of lumber used is necessary, but there is needed only one computation to determine the direction of each.

Most of the stock used by boys in manual training comes within the 3 foot limit of length, but the cost of longer pieces is readily determined by inspection of the charts and suitable multiplication. The writer found such charts invaluable time-savers in shop.

Does anyone think that the sometimes elaborate projects get miraculously done without tiresome details and hard work? Can it be imagined that a school which deliberately seeks to keep its pupils under real life—conditions could or would eliminate the “irksomeness of the steady grind?” Drudgery it does virtually eliminate, for drudgery is a state of mind, due to being compelled to labor without illumination and without understanding and without joy.

—HORACE B. ENGLISH.

THE OLD WAY; THE PRESENT WAY; A BETTER WAY OF TEACHING ANY TRADE

J. H. McCLOSKEY, Camp Grant, Illinois

YEARS ago the young would-be mechanic was bound out to a master, and for many years was under close supervision to acquire knowledge and skill which is to-day only a small part of what any skilled mechanic should have. Then the master had but few apprentices, and no trade was very complicated. Today the teacher in a trade school or the foreman in the shop takes the place of the master and has from twenty to thirty-five students or apprentices. There are many more operations to be taught than formerly, and much less time in which to give the instruction. To get equal results with the masters of old would probably require methods ten times as efficient as those the master used. Possibly somewhat better instruction is given by the foreman or instructor of today, but in many cases that is questionable.

"How do men acquire a trade today?" The answer may well be: "They steal it." There are several ways of stealing a trade. One is for a man, knowing nothing of the trade, to somehow obtain employment in a shop, work a few days until he gets "fired," then go to another place, each time staying longer, until he has picked up enough so he can "get by," and possibly stick until he becomes an average mechanic. Another method of getting a start is thru the vestibule school. After a few weeks of training in this school, the man remains an operator or picks up, i. e. steals, enough so he is able to "get by" as a journeyman in that or some other shop. Still others get their trade by serving an apprenticeship, and a few thru trade schools. In both cases it is necessary to steal a large amount of what they get, for the instructor or foreman has relatively little time to tell and show all that is necessary.

Some people have advocated allow-

ing the student to discover how to do various things, but while the chances of his discovering a good method are possible, they are usually very improbable. In many cases he is liable to learn a poor method, or at least a poor way of performing under any method. While learning a new mechanical operation is not the time to exercise the creative or inventive ability, for the chances of learning wrong are exceedingly great. Therefore, it is important that a student or apprentice learn to perform the operation precisely in the proper manner, for if he does not, the probability that he will ever successfully change from a poor to a good method is slight. It is not impossible to change a habit so formed, but it is difficult, and the result is likely to be quite the same as that attained by many students who were forced to change their handwriting a score or so of years ago. They lost whatever of good the old method may have held, without ever acquiring facility in the new. Surely it is advisable to learn at the beginning a good and, if possible, the best way of doing anything. Stealing—just picking up—a trade is hardly a sensible procedure.

Personal supervision or help seems to be necessary, yet under the existing circumstances, cannot often be given. Will the circumstances change? Will a teacher or foreman be given fewer boys to instruct so he can help them more, or will the time he has them be increased? These changes will not take place. The days of the master and the apprentice have passed, and tho it is said that history repeats itself, let us not deceive ourselves into thinking that the new generations will go back to the old method or that the present system, or in many cases lack of system, will suffice.

Many books that are helpful have been

written about some of the trades, but often these are not readily comprehended by the mechanic, and still less by the student or apprentice. It has not been long that any books on the trades have been very much worth while. A few years ago an excellent engineer, now less than forty-five years of age, whom we will call "Jim" said that he started to learn to be a marine engineer at the age of eighteen. On his second trip down the Mississippi, he bought a set of books. One day the chief engineer of the boat came upon Jim studying, and was enthusiastically shown the books, whereupon he grabbed the whole set and threw them in the river, warning the astonished Jim that he would have no one on his boat wasting time with books, even in hours off duty. The books may have been worth while, but the chances are that the engineer was entirely right. At any rate his attitude was characteristic of many good mechanics of his day and survives even to the present time.

However there is, and long has been, a crying need for the organization of the knowledge required for any trade and the presentation of it in such form that it can be grasped readily by the student. Doctor Prosser at a recent convention, bewailed the fact that there were so many trades and so much about industry that needed to be taught at Dunwoody Institute and that was hard to teach because of no adequately organized knowledge of these trades. He gave as special examples the flour industry and painting, and said that in neither case was there a book worthy of the name, and none less than twenty-five years old, and not one on American practice. He inferred that the same was true of many trades and specialized industries, and his inference is probably correct. President Harvey also spoke along the same line.

Those who have read Professor Sel-

vidge's article in the February *Manual Training Magazine* and grasped the full meaning of the scheme that he gave to the Army Trade School, will recognize in it a simple and economical method of doing that which so sorely needs to be done. By Professor Selvidge's scheme all the knowledge, all the mysteries, all the kinks of all the trades and industries could be put in a form for "all the children of all the people." The Army plan would function well in a trade school on productive work. In a shop where apprentices are being trained they could readily be taught to be reading, thinking mechanics who would plan their work, and so see clear thru the job. This would add much of interest to their work. In night school work each man could be handled with the ease that he would be if one of a class of fifteen or twenty, and still all in the class might be doing different kinds of work. Short unit courses could be easily planned and effectively executed. Some of the leading men in industrial education have carefully looked into the scheme advocated by Professor Selvidge and all have pronounced it absolutely sound and a great contribution to vocational education. Every one interested in this work should study the scheme, learn what it is all about and, if it seems destined to revolutionize trade teaching, they should lend their efforts toward bringing about a movement for the development along similar lines of all the trades and industries. It would cost something in time, money and effort, but if used on as large scale as possible, would save enough in the next generation in the writing of books and in the value of the time spent hunting the information in those books, to pay for several wars.

The agricultural vocations are well taken care of in the various state universities, but where is there an institution

of university rank that bothers about trade teaching? Of course there may be a few that touch on certain trades, but on the whole the trades and industries have had no college education; they have come up very much like Topsy. Trade schools are few and far between, deal with only a few trades and cannot be expected to do research and development work. The universities do not attempt the development work, yet the field is a very fertile one. The information that could be gathered from magazines, bulletins, books and from men skilled in the various trades and industries is a stupendous amount. The manipulative operations of trades are performed in different ways in different parts of the country, and in still different ways in other counties. It undoubtedly would be very much worth while to round up this material and sift out what seems to be best for the use of the learner. But who is to do it? A start has been made at Camp Grant for the Army Trade Schools. Manuals have been completed or partially completed for the following trades. ¹ (1) Canvas work; (2) tailoring; (3) auto trimming; (4) plumbing; (5) carpentry; (6) interior wiring; (7) automotive engine repair; (8) storage batteries; (9) automotive tire repairing; (10) printing, hand composition; (11) drafting; (12) highway construction; (13) general machinist; (14) sheet-metal work; (15) oxy-acetylene welding and cutting of metals; (16) fireman; (17) automobile chassis; (18) automobile starting, lighting and ignition; (19) motion picture; (20) upholstering; (21) blacksmithing; (22) surveying.

The average time used for the trade analysis of twenty-two trades was about five per cent of the total time required to

¹Unfortunately these manuals are not available for the use of schools generally. The War Department has printed a supply for its own use only.

complete the whole manual. In no case, however, was the trade analysis skimped, but was worked over dozens, and in some cases hundreds, of times in an endeavor to get the list which would function best. In nearly all cases the list of operations compiled at first was quite long, but has been cut down to the least possible number. In the "general machinists manual," two hundred forty unit operations were condensed to ninety-four. Those unit operations which are executed together are grouped, e. g. drilling, boring and reaming in an engine lathe, is given as one unit operation. The unit operation sheets take, on an average, about seventy-five per cent of the total time required to finish a completed manual, while the information sheets take but twenty per cent of the time. However, there are trades where the number of information sheets form decidedly the larger part of the manual in both number and in time required for preparation.

The illustrations add considerably to the expense of getting out the manuals, yet they form a very vital part of each manual. They vary in number from twenty-two on some sheets to none on others, averaging three to each operation and information sheet. These illustrations are mostly line drawings and show specifically what the author desires the student to see. They supplement the simple language and make it possible to clearly state, in a way that the student can readily grasp, how to perform the various manipulative operations.

With manuals similar to these in the hands of men who are learning the trades and having their activities directed by an intelligent, resourceful teacher or foreman, each man would have the equivalent of individual instruction for every operation at just the time such instruction would function.



EDITORIAL REVIEW FOR THE MONTH

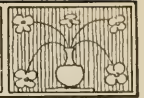

A NEW SERIES OF MONOGRAPHS ON VOCATIONAL EDUCATION

THE Vocational Education Association of the Middle West has just issued the first of a new series of monographs on vocational education. The thought behind this series is that instead of publishing a volume of proceedings to replenish the dark corners of hundreds of libraries the Association will seek out the choicest living messages delivered at its conventions and send these to the larger audience of its entire membership and to all others who are interested in vocational education and will pay a small fee for the monographs desired.

The first of this series is the report of the Committee on Teaching Social Science in High Schools and Industrial Classes. The Committee consists of Ruth Mary Weeks of Kansas City, chairman, Professor John R. Commons of the University of Wisconsin, and Assistant Superintendent Frank M. Leavitt of Pittsburgh. This Committee was announced in June, 1919; its first report was presented at the convention in Chicago in February, 1920. The superior value of this report was immediately recognized, and the demand for copies was greater than could be supplied. The Committee was continued, and a more detailed report was presented to the Minneapolis convention in February, 1921. The monograph is the Minneapolis report, enlarged by a section on "Reading and Lesson Topics." Copies may be obtained at 20 cts. each from the secretary of the Association, L. W. Wahlstrom, 1711 Estes Ave., Chicago.

Any one who believes that the safety and prosperity of this nation is dependent in very large measure upon the economic

intelligence of the great body of citizens must recognize how vital is the subject of this report, and anyone who has heard Miss Weeks in her addresses before the Association must realize that she, not only has a message of inspiration, but of practical detail for every teacher who believes in a real Americanization program.

The report outlines thirty-three lessons and gives references for each lesson. It includes, also, a sample lesson and a discussion of the relation of social science to the whole course of study.

It is expected that several other monographs in this series will be issued during the year.

A SURVEY OF MECHANICAL DRAWING

FACTS and figures concerning the time and emphasis given to the subject of mechanical drawing in sixty-three of the larger American high schools have been compiled by a committee of teachers in Cincinnati, Ohio.

In fifty per cent of the sixty-three schools a textbook on mechanical drawing is used; in thirty-nine per cent no book is used; while eleven per cent make use of pamphlets and blueprints.

The report shows, further, that the subject is elective for boys in seventy per cent and elective for girls in forty per cent of the schools. In thirty per cent the classes consist of both boys and girls. The largest attendance of girls is found in the Western states—the Vocational High School, Oakland, California having one hundred enrolled; Billings Polytechnic Institute of Billings, Montana, sixty; and the Salt Lake High School, Salt Lake City, reporting an attendance of twenty-five.

With reference to the time per week devoted to the subject, the following is of interest:

In the first year the time devoted is 350 minutes in twenty-five per cent of the schools; 225 to 350 in thirty-six per cent; while less than 225 and more than 175 minutes is given by twenty per cent of the schools. The second year has practically the same schedule as the first. In the third and fourth years the time allowance is 350 minutes in about sixteen per cent; 225 to 350 minutes in about forty per cent of the schools.

The information printed in the pamphlet was gathered from sixty-three reports which came in response to a questionnaire sent to each of seventy-five different high schools by the committee which was headed by R. G. Bilger of the High School Industrial Arts Department. The pamphlet contains a list of the high schools which replied to the questionnaire in addition to much other information of interest to the mechanical drawing teacher.

The pamphlet was printed by the classes of the printing department of the Woodward High School.

ARTHUR DEAN ACCEPTS APPOINTMENT IN VETERAN'S BUREAU

A LETTER from Arthur Dean, dated in Washington, D. C., on the 24th of August, stated that he had become the assistant director of the new Veterans' Bureau. Our reply and similar ones caused him to write the letter printed below. We may as well confess that the viewpoint of our letter now seems to us to have been very cramped and selfish compared with this one from Dean. If all of us—teachers and other citizens—would place public duty ahead of physical ease and intellectual satisfaction, this country of ours would surely be better than it is today. Everybody will recog-

nize the eminent fitness in the appointment of Professor Dean to this very important work, and after reading his letter, every one of us ought to omit qualifications from letters of congratulation.

We are happy to report that this new work will not prevent Mr. Dean from continuing to write as usual for this Magazine. On the contrary, we believe it will make his contributions even more valuable because he will see industrial education problems in the light of new experiences.

September 1, 1921.

Dear Bennett:

By this time word has gone out that I am assistant director of the U. S. Veterans' Bureau. The letters of congratulation which I have received express regret that I have "left" Teachers College, and wonderment that I deliberately chose to accept an appointment which involves responsibility and reputation when I was so "well situated" in a professional chair.

Perhaps a statement to the "boys" thru your editorial chair will clear the situation. In the first place, I have not "left" the College. Much against my personal inclinations, I was drafted for an emergency service. The length of time I shall be away from the College depends upon the exigencies of the service. My college work, for a short time, will be suspended. Plans are under foot for carrying it on before or during the second semester under a scheme which, in my opinion, is a better one than would exist if I were there. Announcement will be made later.

As regards "reputation and professional standing," I have been in a "gainful occupation" for twenty-five years. I have deliberately sought experiences and answered that inner urge for new fields of expression—grammar school manual training, high school supervisorship, administrator and teacher of academic work, extension teaching and supervision, state directorship, college professorship, army service and now, for a time, second or third from the last experience before I see Horace Mann, Pestolozzi, Froebel, etc., (please excuse my presumption), I take up a new work.

Being an ex-service man and having had some educational, army and administrative experience I was practically obligated to accept an appointment in the newly organized Veterans' Bureau.

To participate in the organization under one administrative scheme of combining the War Risk

Insurance Bureau, the Public Health Service, and the Rehabilitation work for disabled soldiers is, I am sure, an obligation, if not a privilege. To participate as a staff officer in the wise spending of nearly a million dollars a day, in organizing the daily work of ten thousand employees, in working thru 125 local offices in 14 regional district offices—all for the benefit of those men and women who served in the Great War—is an opportunity not only to render public service; but also to gain further knowledge of things and men useful to a professional man.

To place the last first is to fail.

Very cordially yours,
Arthur Dean.

PROFESSOR JACOBS GOES
TO SANTA BARBARA

CHARLES L. Jacobs, associate professor of industrial education at the University of California, has gone to the State Normal College at Santa Barbara. His special work at the University was training vocational teachers. His new position is that of head of a department which is designed to train "all kinds of industrial arts and vocational teachers."

The legislature of California has raised the grade of the normal schools to that of college. These institutions now have full college status and can grant the bachelor's degree to persons completing the four-year courses.

This gives special significance to the Santa Barbara school, which, from its beginning, has specialized in training teachers of manual arts and home economics. Viewed from this distance, it would seem that Professor Jacobs is taking the key position in industrial teacher-training in the state of California. The University's distinctive work, as we suppose, is to train supervisors.

AMERICAN METALWORK
OF THE EIGHTEENTH CENTURY

THE following is quoted from the Bulletin of the Metropolitan Museum of Art for June, 1921. That Museum held a summer exhibit of American metal-

work and fixed decorations, lasting thru September.

The fittings and appointments of the American house of the eighteenth century were amazingly complete and varied. Then, as today, the standards of living controlled largely each householder in the quality and variety of his household equipment, but the customary life of the period rendered peculiarly uniform the types of these fittings. Aside from the movable furnishings of the house—furniture, textiles, glass, and silver—there were the many details of more or less fixed decoration which really are a part of the architectural scheme of the house, and upon which was concentrated some of the finest craftsmanship of the times.

The objects shown were chosen chiefly for their interest and value to the housebuilder who is following today in the early American tradition. Interesting treatments of door hardware (see accompanying illustration), leaded glass transoms, and side-lights, of fireplace and lighting fixtures have been gathered together not with the idea of showing every variation of any type but to include chiefly pieces which contain suggestions for modern application and use.

In choosing the objects to be shown, the effort was made to limit them to work which bears the stamp of American production.

THOMAS CHARLES

ANOTHER pioneer worker in the field of industrial education has passed out of this life. On August 16th Thomas Charles died at his home in River Forest, Illinois, at the age of 91 years. Mr. Charles is personally known to but few of the younger men in the profession, tho most of them are acquainted with the business firm in Chicago that bears his name.

To the older men—especially to those who were engaged in manual training work in the Middle West thirty years ago, Mr. Charles is known as a friend and adviser. Before that time he had been a student under Horace Mann at Antioch College and a teacher in Indianapolis and Chicago. Against the advice of his friends, he had established the first kindergarten supply house in the Middle West and had become a promoter of

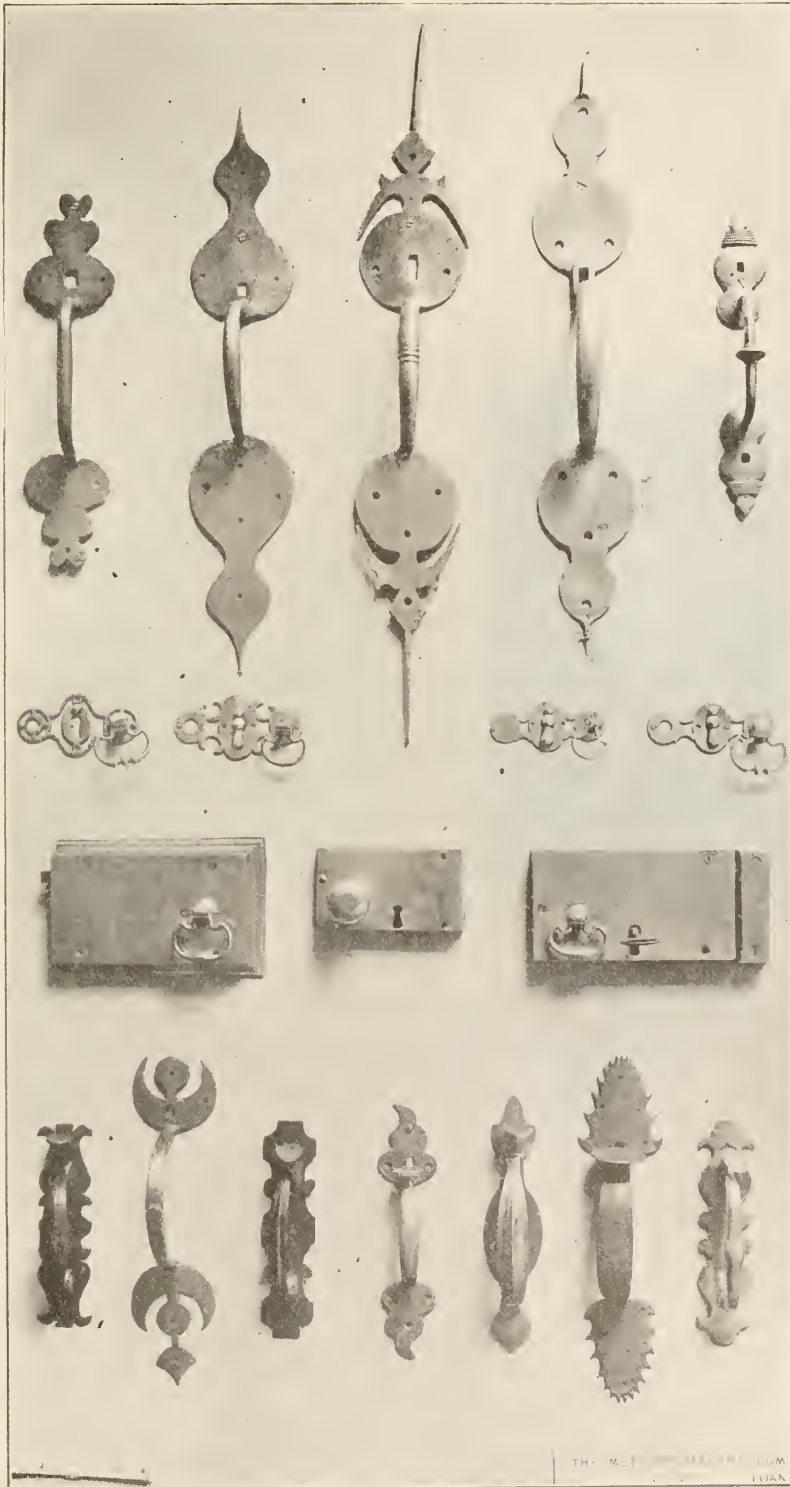

DOOR HARDWARE, EXHIBIT OF AMERICAN METALWORK,
METROPOLITAN MUSEUM, NEW YORK CITY

kindergarten principles. It was very natural, therefore, that he should welcome the advent of manual training for older children. In this movement he foresaw a great development in educational thought and practice and the need for materials which someone must supply. With a long business look ahead and a progressive educational philosophy he became a real pioneer in promoting manual



E. A. FUNKHOUSER

training just as he had been a promoter of the kindergarten. He was a conspicuous figure at conventions of manual training teachers and, in his little office in Chicago, he was a genuine friend to many a young man and young woman who had caught a glimpse of the "new education" but needed the guidance of an older hand.

I, personally, recall how, when I was trying to work up a manual training exhibit for the N. E. A. convention at St. Paul in 1890, he took me to La Porte, Indiana, paying my expenses, in order to

give me a chance to secure the co-operation of Dr. and Mrs. W. N. Hailman. Mrs. Hailman was a famous kindergarten at that time, and Dr. Hailman, as superintendent of public schools, was developing some very progressive work in manual training. Taking me to La Porte was done in the finest professional spirit—"no string tied to it," unless it were the cord of friendship that never has been broken. That was typical of the man. He did for the Middle West what Milton Bradley did for the East. Together (for they worked together) they were two educator-business men who have rendered great service to education.

A NEW REPRESENTATIVE IN THE SOUTHWEST

THIS Magazine has secured the services of E. A. Funkhouser as Southwestern representative. He takes the place of E. E. Erickson, who is now a member of the office editorial staff in Peoria. Mr. Funkhouser is a graduate of the State Teachers' College at Kirksville, Mo., where he received the degree of B. S. He has done summer work at the University of Chicago and the University of Illinois, and has had practical experience in the carpenter's trade. He taught manual training at Galena, Ill., two years, was supervisor at Winnetka one year, and then went to the State Agricultural School at Jonesboro, Ark., where he was director of manual arts. After two years he went to his present position as head of the manual arts work in the John Tarleton Agricultural College at Stephenville, Texas.

Mr. Funkhouser will be glad to have the co-operation of all the leaders in his territory so that he may make his monthly reports a true index of the progress in industrial education in the Southwest.

Each man's work means every other man's additional comfort and leisure.

CORNELIA J. CANNON, in September *Atlantic*.

A POINT OF VIEW

A PROPHECY

THIS is not a valedictory. I shall see more of the country than ever before. I shall meet more of you fellows in the field. I shall be closer to national programs of vocational and general education, to educational work in the Army, to National Associations for the Prevention of Educational and Social Mistakes, to schools and colleges, to employers and employees, and to courses of study and procedures.

For a time this may be my last purely pedagogical point of view. So let me open up my head and heart to you. This, my only vacation day, is too fine to be pessimistic. Yet, I am frankly puzzled by several things and it is of these I would speak.

CONCERNING CONTINUATION SCHOOLS

In the first place, what are we going to do with our compulsory continuation schools for youth between fourteen and sixteen? At present, they are very unsatisfactory (exceptions of course). Pupils do not like to attend them. Teachers are not prepared to teach in them. Correlation of work day experience with school work is difficult. Proper textbooks are lacking. Compulsory attendance of all is in name only. Social and economic knowledge of the problem is lacking on the part of all concerned.

My prophesy is that the idea will be put on the scrap heap inside of five years. In its place will be compulsory full-time attendance up to sixteen years of age. The reasons in brief are as follows: (a) prevocational training and guidance will be a part of the junior high school movement. Adolescent youth can be better served in such a scheme than in a four-hour-a-week program in the continuation school. (b) Elementary education is the job of the elementary and regular schools and that is about all nowadays that the

continuation schools are doing or can do. It should not be necessary to get a child to work in order to give him what he should get in a regular full-day school. (c) The children now in the regular schools need useful education and the children now at work need useful education. Both programs for 14-16 year old children can be met in all day schools when the curriculum is socialized, vocationalized and liberalized.

CONCERNING THE JUNIOR HIGH SCHOOL

In the second place, what are we going to do with our junior high school? The talk about it is big. The actual program is mighty small. With few exceptions its interpretation means merely that high school work starts earlier and traditional subject matter is jammed down the throats and into the ears of infants. Algebra, geometry, Latin, French, German, formalized manual training, book-keeping, etc., have no more place in the 7th year or 8th year than they have in the ninth year. These children are adolescent youth and should not be implements in the hands of school men who are interested in concoctions of building programs, "getting to college earlier," or "adjustments" of elementary and secondary school problems. Hardly a soul in discussing junior high schools ever mentions children.

My prophesy is that the "regular" school man is going to give but little attention to adolescence. He knows little about children and much about courses of study. The "irregular" school man is in a minority in the recognition of the value of activity work along varied lines and offered for at least one-third of the school day. The junior high school is going to take little cognizance of boys interested in telegraphy, automobiles, airplanes, electro-chemistry, photography, boat making, etc., and is going to give him

the old "hand me down" of formal shop-work. Further more, the men who are running the junior high schools are going to give the industrial arts teacher the same old corner room in the basement and the same equipments of woodwork-ing and mechanical drawing. Those who think they are more liberal are going to add printing, sheet-metal work and light machine work. All of them will forget that boys do not do these things in their free hours. These formalists will insist on "good technical" work rather than on the amateur spirit of expression. They will continue to look at the model and not at the boy.

CONCERNING SURVEYS

In the third place, what are we going to do with "surveys?" The educational world is either wild over them or else those who are making it a business to make surveys are good salesmen. Now-a-days, "before anything is done let us have a survey" is the talking angle. The obvious is carefully tabulated. The unobvious is scientifically discovered. A "correlation" is established and the "curve of dependability" is drawn. A group of experts who have never driven an educational car gather around them a group of students who are learning to drive. Close observations and carefully organized data proves that the car has four wheels, a chassis, an engine, a trans-mission and a rear axle. It's solemnly recommended that each car should have four wheels and that very probably there is a "correlation" between engine power and turning the wheels. A series of driving tests prove that morons have fewer accidents than females and that tire makers have nothing to do with tacks on the road. The recommenda-tions state that a Rolls-Royce engine put under the hood of a Ford, built upon a Maxwell chassis, connected by a Buick

transmission to a Hudson rear axle will make a very excellent sedan.

The report looks impressive. It is impressive. But, like all formal, im-personal, "applicable anywhere" type of study, its only terminal is a Ph. D. thesis for some deserving student.

My prophesy is that the survey idea on the present basis will soon have its headstone. One expert, or three at the most, can tell the sort of educational car which is needed for a given type of service under a defined financial limita-tion. He will recognize demands and necessities of varied communities. He will think of what is feasible rather than that which is theoretical. He will build upon what is already good rather than pull down all the old structure and erect and educational air castle. He will be an educational engineer with the contract to remodel rather than the contract to demolish.

CONCERNING TESTS

In the fourth place, what are we going to do with "tests?" We had the "iron age" then the "steel age" and then the "concrete age." Now, it is the "test age." When the last now-the-truth-may-be-told book is written it will probably be proved that the psychologist won the war. He is certainly the big chief in the present school system. He has developed wonderful formulas for humans thru the study of mice. He has vivisected cats that he might know about boys. He has developed "correlations" to prove the un-provable.

He has shown us that a child of x years should know y words and be able to add z figures of w places. He has demon-strated that there are x percentage of people below capacity to master Went-worth's improper fractions and y per-centage of those who can tell why George Washington was. Without him the doc-

tors and masters of education would have no scientific data on which to base their job. With him by their side they have plenty of data but little knowledge. Horace Mann, Froebel and Pestalozzi surely were back numbers. They were only interested in children.

I prophesy that "tests" will have a lingering death and that some day the spirit of children will receive some attention. Some day we will discover that Life, as expressed by individuals, is a very complex affair. We will learn that a smile, a knowledge of how to count change, a technical knowledge of one's business, a good body, a respect for others, a human understanding and a general application of horse sense may produce an efficient worker, a good citizen and a decent parent. This man may or may not have 5,000 word vocabulary (a careful elimination of about twenty words in the vocabulary of the average man will do more towards success than possession of 2,500 seldom used words). He may or may not know about fractional inversions or respond to proper index finger reactions when tickled in the fifth rib.

In short there is a mystery in Life. There are infinite combinations. Its alphabet may have but few qualities but its dictionary of expressions is infinite. To measure capacity and success in life expressions by ability to pass the _____ arithmetic test, the _____ reading test, the _____ word test, the _____ reaction test is to play with the Infinite.

CONCERNING VOCATIONAL GUIDANCE

In the fifth and last place, I am puzzled by "vocational guidance." I was once unkind enough to say that to give it was like a blind man on a dark night to chase a black cat that was not there. It was intended as a bit of pleasantry. It was taken as enmity. I believe in vocational

guidance, I believe in Life, in God, in the Infinite, in the Universe and in Boys. The last and all the rest are wonderful, mysterious and Divine.

I am so much interested in boys that I am not a believer in the statement that blue eyes and light hair make good something-or-other nor that double chins imply some thingamajig. I am not inclined towards the idea that success in school means a door tender's job in Heaven, or that failure to demonstrate vocational aptitudes at the age of twelve means that the interlocking switch will not move before forty. I do not anticipate that a school teacher whose vision is limited to a normal school or a teachers college can counsel effectively a human unknown quantity and get the proper Q. E. D. I do not believe that an over supply of enthusiasm at the age of fourteen for shocks from an electric machine qualifies for anticipating a second Thomas A. Edison. I have little faith in a form of self analysis which, when finished, looks like a Sunday school reward of merit.

I do believe with all my heart that the two great things in life are Work and Friends, and that the greater of these is both in happy combination. I believe that next to Life itself is the mystery connected with one's work: why he goes into it, why he stays by it, what he does it for, and why he succeeds or fails. Science has pulled the flower, the fly, the fish, the sky and the tree apart. It has put them together again. It has (i. e. men like Fabre and Shaler) stopped at these two points and it has raised its hands as an expression of failure to solve the unsolvable and as an expression of reverence for the Divine Order. Yes! there is a mystery to vocational selection and success.

I prophesy—but Bennett writes me that my articles are too long.

—ARTHUR DEAN.

WASHINGTON CORRESPONDENCE

RECENT EDUCATIONAL DEVELOPMENT IN THE ARMY

A NUMBER of circumstances have conspired to prevent me from recording in these columns as faithfully as I should the development of the educational program of the U. S. Army. Announcement of certain changes in the organization which had taken place since General Pershing became Chief of Staff attracted my attention, and I made some further inquiries. General Rees and General Haan, who have been closely identified with the educational work of the Army, have been assigned to duty elsewhere. General Rees has been detailed to the Army War College, and General Haan to service in the Philippines.

I noted, further, that the "Education and Recreation Service" has been changed to "Training and Instruction," and the work has been transferred from the War Plans Division of the General Staff to the Operations Division. It is intended to continue and develop the educational work, altho it was determined some time ago to proceed in the direction of replacing civilian educational directors and instructors with men in uniform as rapidly as possible.

PROCEDURE FOUND EFFECTIVE IN VOCATIONAL TRAINING TO BE APPLIED TO MILITARY TRAINING

THE point that interested me most in what I learned on my visit to the War Department was to find that plans are now under way to apply to the task of training infantry combat troops certain principles which have been found effective in vocational training. To put it in the fewest possible words, it has been decided to make a "job-analysis" of the duties of the infantryman when engaged in battle, to formulate objective methods of determining degrees of proficiency in

the performance of these duties, and to perfect plans and methods of training based on these findings.

A memorandum prepared in the Division states the problem as follows:

(1) A statement should be prepared showing what are the minimum abilities and attributes required of each individual. Such a statement of things each type of soldier must be able to do constitutes the minimum personnel specifications which define the objectives of each kind of training.

(2) Standards of proficiency must be created, consisting of standardized objective tests, designed to determine when the abilities mentioned in the personnel specifications have been acquired thru training. When properly developed and used, such tests concentrate the attention of both soldier and instructor upon the rapid achievement of the degree of proficiency defined by the standards.

(3) There should be prepared an instructor's guide, explaining the principles of training, and the methods of using effectively the standards of proficiency both in peace and under mobilization conditions.

(4) There should be prepared a time schedule based upon the best available experience and special experiments with troops, showing normal progress in training to meet the standards.

It is worth while for those who are engaged in the manual arts field, or in vocational education, to realize occasionally that the leaders in both of these movements have done constructive work of such importance that its influence has been felt in many ways in general educational theory and practice. It is an even more striking confirmation of the essential soundness of the pioneer work done years ago to find its results now useful to the Army in military training.

MAJOR HENDERSON RETURNS

I WAS much pleased to find Major Wilson H. Henderson back in Washington. After his discharge from the Army a little over a year ago, he left Fort McHenry, where he had been educational director, and was sent to the Hawaiian Islands as civilian vocational educational consultant for that Corps

area. He will now be stationed in Washington for a time, assigned to assist in the work of compiling and revising the Army vocational handbooks.

In the same office I ran into E. S. Maclin, who was recently appointed professor of industrial education at the University of West Virginia, and who

the new plan. The following abstract of a portion of this statement will be of interest:

Briefly stated the functions of the Bureau of Education are conceived to be: (1) To be informed on all subjects pertaining to education; and (2) To make the information which it possesses effective in promoting the cause of education.

I find that the Bureau, in the discharge of these

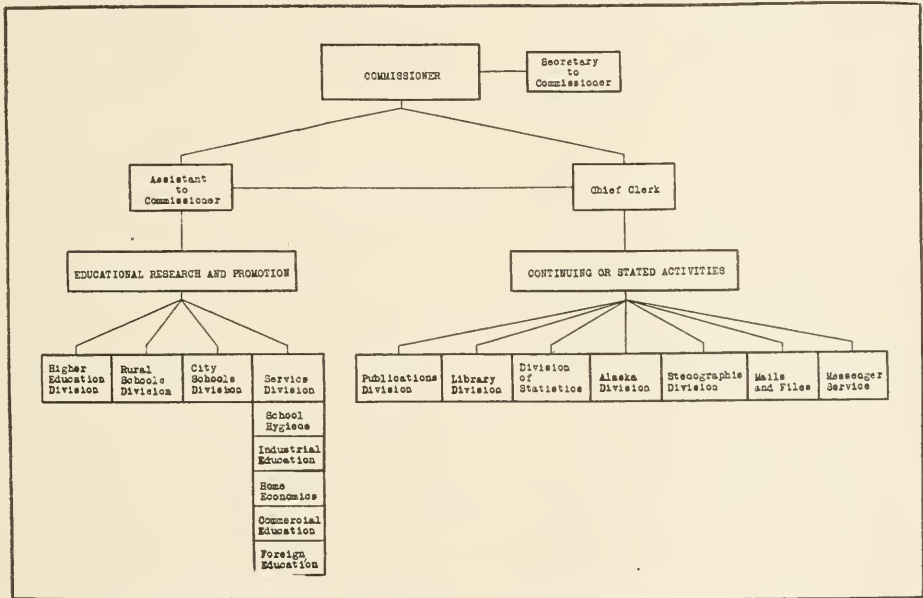

CHART SHOWING NEW PLAN OF ORGANIZATION OF THE UNITED STATES BUREAU OF EDUCATION. (REPRINTED FROM *School Life*)

takes up his new duties at Morgantown early in September. He has served as shop instructor at the University of Wisconsin, for two years as state supervisor of industrial education in Tennessee, and for the past year as educational specialist and corps consultant at Camp Jackson.

REORGANIZATION OF THE BUREAU OF EDUCATION

DURING the summer months Commissioner Tigert has been busy effecting a reorganization of the United States Bureau of Education, and has contributed to the September number of *School Life* a brief statement outlining

functions, has been undertaking a considerable variety of activities, which may be roughly divided into two main classes, with subdivisions as follows:

- (1) Continuing or stated activities:
 - (a) Business administration of the office.
 - (b) Administration of the educational system, medical relief, and reindeer herds, for the natives of Alaska.
 - (c) Administration of certain provisions of law relating to the State Colleges of Agriculture and the Mechanic Arts.
 - (d) Collecting and compiling statistics.
 - (e) Library service.
 - (f) Publication and distribution of documents.
 - (g) Stenographic, clerical, and other incidental service.
- (2) Educational research and promotion:
 - (a) Studies of various phases of education for the purpose of acquiring and digesting information.

(b) Preparation of manuscripts for publication as circulars of information, or bulletins, or portions of bulletins.

(c) Counselling with school officers, legislative committees, boards of school trustees, and others, and giving advice on educational matters.

(d) Official correspondence with seekers after information, advice, and other assistance.

(e) Representing the Bureau at educational conventions for the purpose of keeping in touch with leaders and movements.

(f) Public addresses on educational topics.

(g) Organizing and conducting special conferences of educators and others.

(h) Organizing and conducting educational surveys, and preparing reports and recommendations based upon such studies.

PRESENT PERSONNEL OF THE BUREAU

For carrying on the work of the Bureau, exclusive of the work in Alaska, we have now in the offices at Washington 87 people. Of these, approximately one-fourth are specialists engaged in the various lines of research and promotion, the remainder being made up of employees in the statistical division, librarians, stenographers, clerks, and others.

The form of organization decided upon is based on the analysis of activities indicated above. We have in the Bureau these two general types of activities: *first*, the activities of a more or less routine character, which I have termed continuing or stated activities; and, *second*, the activities of experts in the various fields of education, whom I have designated the technical staff.

There are seven divisions of those activities which I have termed continuing or stated activities, and I have placed them under the general direction of the Chief Clerk of the Bureau; including—Publications Division, Library Division, Division of Statistics, Alaska Division, Stenographic Division, Mails and Files, Messenger Service.

The technical staff has been organized into four divisions under the direction of the Assistant to the Commissioner, including—Higher Education Division, Rural Schools Division, City Schools Division, and Service Division, the last named comprising certain individuals and smaller divisions which have been consolidated into one administrative group.

THE ADVISORY COUNCIL

To provide for more definite correlation of the activities of the technical staff, and to increase the effectiveness of our work by promoting co-operation thruout the Bureau, it has seemed to me

advisable to bring all the activities of the Bureau, and more especially of the technical staff, under the review of a general advisory body, corresponding roughly to the council of deans or similar advisory bodies which exist in colleges and universities.

I have, therefore, appointed such an Advisory Council, composed of the heads of the Research Divisions, together with the Chief Clerk, with the Assistant to the Commissioner as chairman. It will be the duty of the Advisory Council to consider and advise with me concerning general questions of educational policy, and procedure in the more important projects to be undertaken, and to assist me in such ways as may be determined hereafter.

OTHER CHANGES

I NEGLECTED to report last month the appointment of former Commissioner Claxton as Provost of the University of Alabama, at Tuscaloosa, effective July 26th. When I saw Dr. Claxton just before he left Washington I found him quite enthusiastic about his new work. He is to have no responsibilities in connection with the student body on the campus, or the internal administration of the University, except that he is to give one or two courses of lectures. His chief concern will be with the citizens of the state. In the language of current magazine literature, his job is "to sell the idea of higher education to the people of Alabama," and he has been given freedom to determine his own program and methods. This is a large order, but every one who knows Dr. Claxton knows that he is peculiarly fitted for the task. Alabama, and the South generally, are to be congratulated.

According to my latest information the vacancy caused by the expiration of Mr. Munroe's term of office as member of the Federal Board for Vocational Education has not been filled, and I should not be surprised if it remains unfilled for the time being. Mr. Fidler, who is the member representing labor interests in the Board, continues as acting director, having been designated to that position

at the time Mr. Lamkin resigned. Mr. Carris, who has been assistant director for industrial rehabilitation, has been placed in charge also of the Smith-Hughes

vocational education work, taking over the administrative duties laid down by Mr. Hawkins.

—WILLIAM T. BAWDEN.

IN FOREIGN COUNTRIES

LONDON LOWERS THE AGE LIMIT FOR CONTINUATION SCHOOLS

AFTER extended discussion of the new continuation schools with reference to the increasing financial demands, the London County Council has decided to adopt the illegal policy of restricting the operation of the Education Act of 1918 to young persons under the age of 15 years, whereas it should legally be 16 years. Viewed at this distance the action appears to be merely a slowing down of the process of putting into operation a law that is very generally recognized as good, but difficult to finance under present conditions. Even so, it was the subject of many and vigorous protests from officials, teachers and representatives of the Press who are interested in popular education.

THE EFFECT OF THE WAR ON CONTINUATION SCHOOLS IN GERMANY

THE U. S. Department of Labor has recently issued an article by Anna Kalet of the Children's Bureau on the effect of the war on the working children of Germany. In this article, which appeared in the *Monthly Labor Review* for July, Miss Kalet said that "the apprenticeship system, which before had been regulated by well defined and thoroly enforced laws, was seriously affected by the disorganizing influence of the war." In-

structors of apprentices were often drafted; apprentices received little individual attention; much higher wages were paid outside of apprenticeship; these, with the minute subdivision of labor seriously broke into the system. Then the writer adds,

"Continuation school instruction suffered as a result of the war even more than apprenticeship. Before the war attendance at such schools was compulsory practically thruout Germany for all workers under 18 years of age. The number of hours prescribed varied from two to twelve per week, according to local regulations. The system was well organized and the law thoroly enforced.

During the war, however, many changes took place. Some schools were closed; even where this did not happen, their work was very greatly curtailed. Many of the teachers were drafted. In a number of cases the school premises were entirely or in part requisitioned for military purposes. While not a single district inspector fails to mention this situation, some are particularly emphatic in their utterances. * * * * *

Decreasing the number of hours of attendance required at continuation school classes was very common. An even more serious evil was the very frequent practice of permanently excusing children at the request of employers who, on account of the pressure of war orders and the high value of child labor, objected to allowing their young workers the time necessary for continuation school training. Such requests apparently were always granted; at least no case of refusal has been reported. * * *

Even the children who attended continuation school were so worn out by the unusually long hours and hard work in the factory that they could not receive from the instruction the same benefit as in normal times."

Democracy has discredited education as a philanthropy, and recognized it as the right of every potential citizen, the only insurance against the anarchy of ignorance, and the sole safeguard of the institutions of a free people.

—CORNELIA J. CANNON.



PROJECTS, PROBLEMS AND NOTES

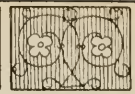

MORE PROBLEMS FROM ST. LOUIS

FOLLOWING the elementary woodworking problems from St. Louis given in September are four more plates belonging to the same collection. The first two are intended for seventh grade pupils and the last two for eighth grade.

The spoons and forks shown on the fourth plate proved to be very popular in a school in a German neighborhood. One boy wanted to make one of these and then other boys followed. The parents became interested because the price of such articles had gone up to a very high mark, and before long the manual training shop was essentially a fork and spoon factory, so far as the product turned out was concerned.

This experience was a fine demonstration of the fact that there is no use in condemning a problem because it came from the sloyd of Sweden or the handicraft work of Germany a generation ago. The question is not one of the age of the idea, but is decidedly one of present use, and especially, of present interest to the individual pupil who makes it. If a salad fork and spoon cost a dollar in the market, and if the boy can produce as good ones at an expenditure of five cents, why should he not do it, provided he wants to, and that the making of it involves good tool exercises? What matters if it could be made quicker by machinery?

TEACHING LETTERING

REGARDLESS of the fact that there is probably no one feature that makes or mars a drawing as does the lettering, it is extremely difficult to arouse any great degree of enthusiasm in the subject. The pupils look on the practice that is necessary to produce skill as disagreeable and unnecessary, and it is difficult to motivate it and thereby create the proper spirit. I am offering my experience in the hope that it may be of value to some one.

I tried talks on the development of the written language from the hieroglyphics of the Egyptians, showing the evolution of some of the different letters from the pictures of an animal or a bird to the present form. I spoke of the picture language of the American Indians, and other savage tribes. I told of the Indian sign language, and showed a few of the signs that I thought would be of interest. I spoke of the deaf mutes and their signs and led up to the marvel of our written language and its great importance on the drawings. The class listened politely on the different occasions that I tried out one idea after another, and then fell to

their work with evidence that it might be necessary but, to them, at least, it was not a subject for wild enthusiasm.

Then I tried an experiment.

We had divided the alphabet into four groups, including the letters made up of horizontal and vertical lines only—E F H I L T—in group A, those having slant lines—A K M N V W X Y Z—in Group B, etc. I suggested a contest to see who could make the greatest number of words using only the letters in Group A; then the best sentence using only those words. No entry was to be considered unless the lettering was of a standard approved by the instructor.

Next we took those words that could be formed from the letters in Groups A and B, and from these made sentences, requiring, as before, that the letters be properly proportioned and correctly spaced in words and sentences. Using the letters in Group A B and C we made other words and sentences, trying to utilize as many of the letters in Group C as possible. Last, we asked for the best sentence that would contain all of the letters in the alphabet.

The lists of words are too long to be given here. A few of the sentences follow. The first of the long sentences, which is the best, is not original but the boy who handed it in was unable to tell where he had heard it.

The experiment was a tremendous success. By the time the novelty had worn off the majority of the boys had acquired enough skill so that they took a real pride in their work and the lettering on plates was greatly improved.

HE HIT THE THIEF. HE FELT IT.

LET IT FLY, TIM. THE MAN KILLED THE LAZY ELK.

THE MAN KILLED THE LYNX WITH AN AX.

THE MAN WILL MAKE A KITE.

GO QUICK, OLAF, AND CATCH THE COW.

FROM THE CRITICS CAME THE OPINION THAT THE "MARK OF ZORRO" TOOK VERY QUICKLY WITH THE JOY-SEEKING PUBLIC AS AN EXCELLENT DRAMA. BG

A PICKED POLICEMAN'S JOB IS GREATLY VIGORIZED WHEN THERE FOXY THIEVES TO QUELL.

OUR HORSE, JIM, WAS VERY LAZY AND THE ROAD WAS BUMPY AND MUDDY, THEREFORE WE DID NOT REACH BIGHORN AS QUICKLY AS EXPECTED.

CAMP STOOL

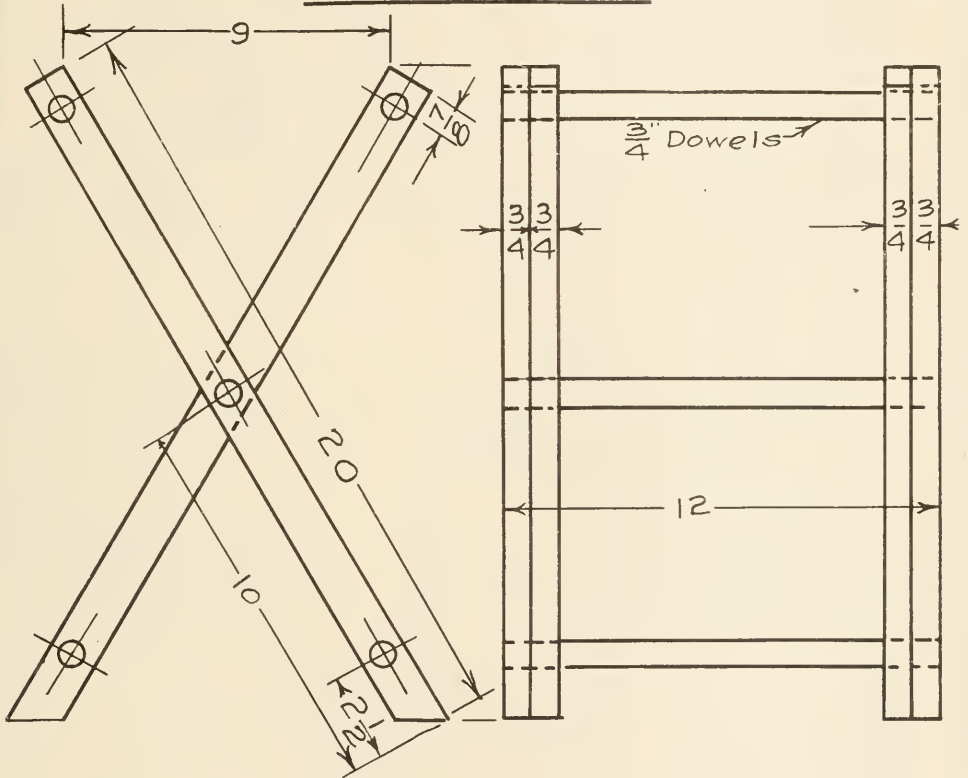

TOWEL HOLDER

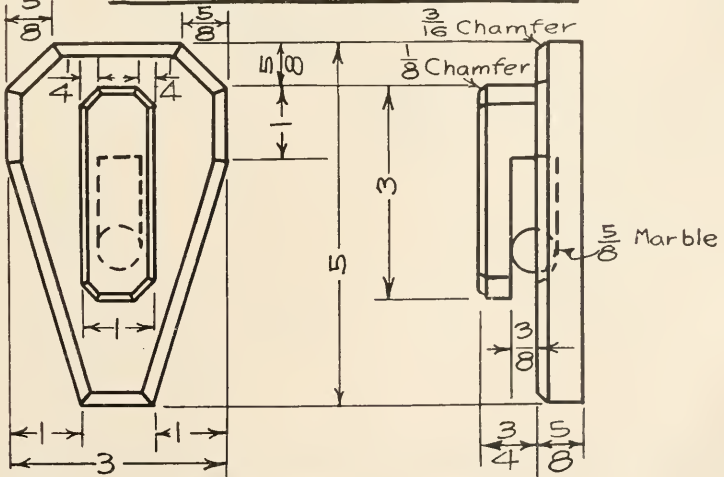

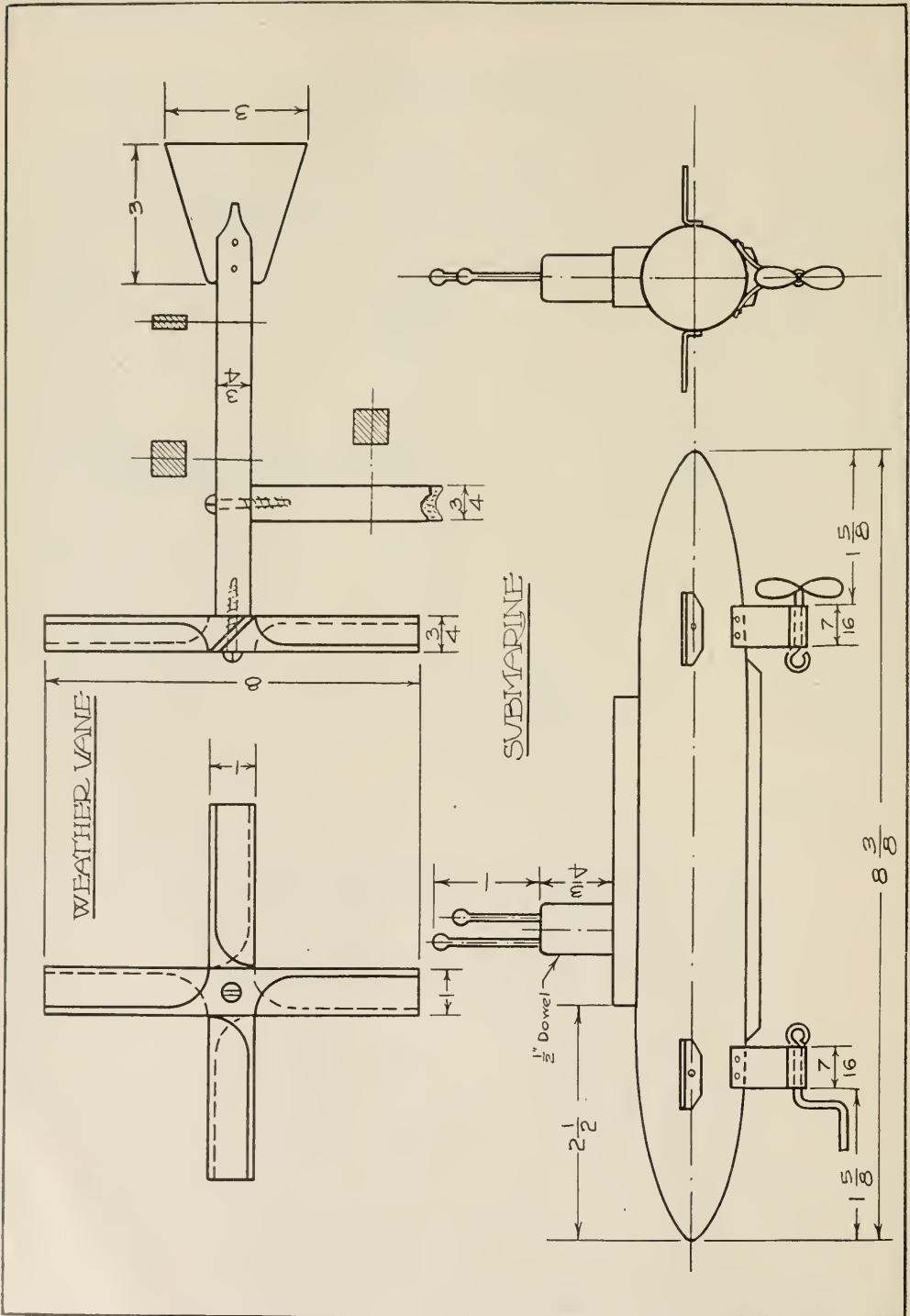

TEA-POT STAND

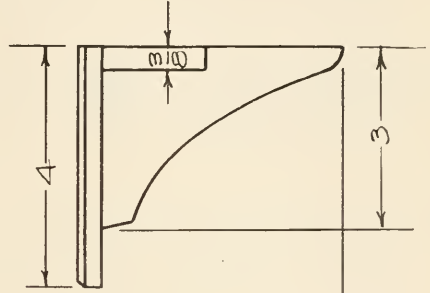
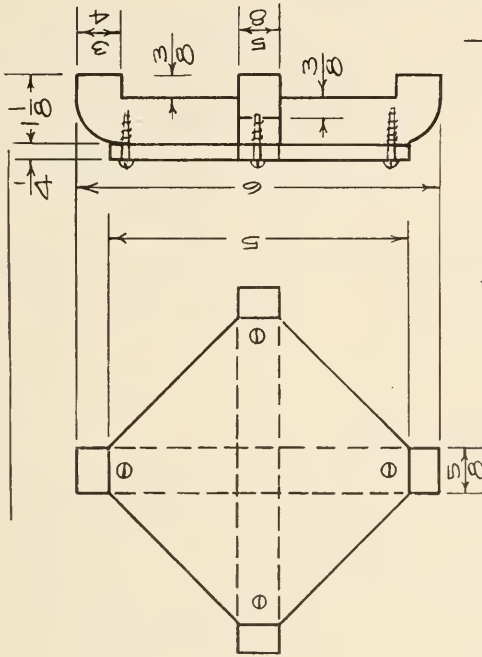

LETTER HOLDER

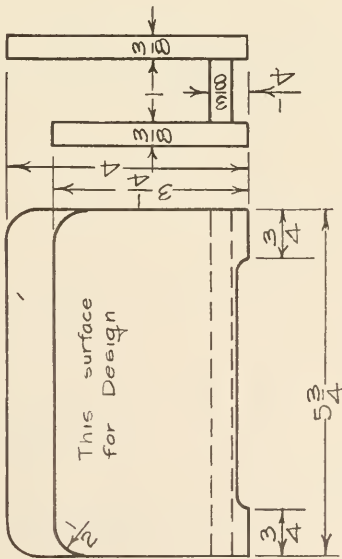

BRACKET SHELF

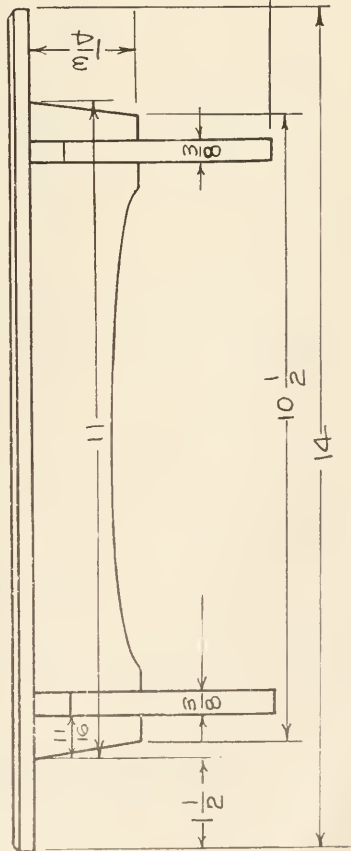

STIRRING SPOON

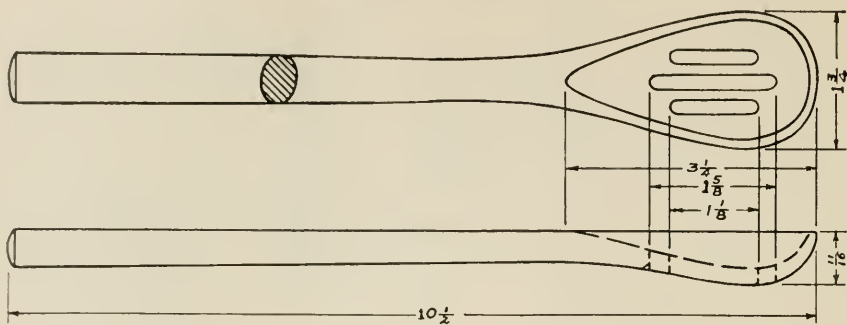

SALAD SPOON

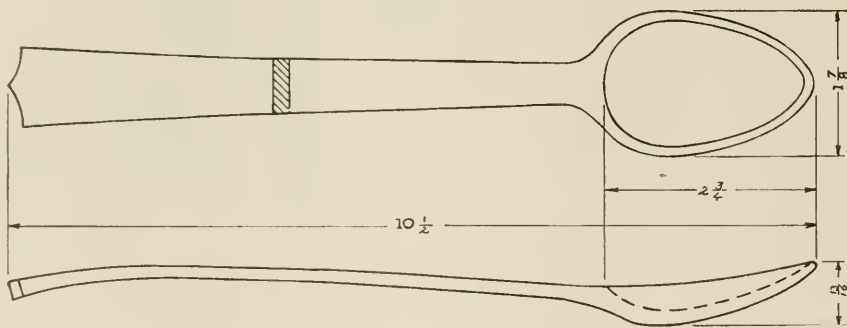

SALAD FORK

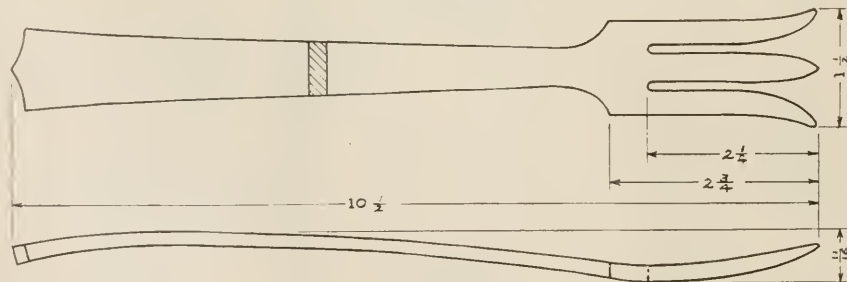

ZADOVSKY IS COACHING WEST'S TRACK TEAM TO VICTORY IN SPITE OF THE STUBBORN PUPILS QUEER LACK OF GINGER. JX

THE HEAVY, WELL-BUILT MEN WERE STRUGGLING TO KILL THE JACKAL, FROM THE ZOO, BUT IT WAS QUITE STRONG, AND EXERTED ALL ITS POWER TO ESCAPE.

THE ZOO WAS INCREASED VERY MUCH BY ADDING FIVE LYNX, TWO JACK-RABBITS AND A FEW KINDS OF QUEER PARROTS.

—W. W. STURTEVANT,
South High School, Minneapolis.

THE BUTCHER KNIFE
AS A FORGE PROJECT

HAVING tried out the butcher knife as a forge project I find the boys display more than usual interest while at work on it. I am going to give it to the readers of the *Manual Training Magazine* as I have worked it out. It takes from six to eight periods to complete, and I find that it brings many favorable comments from the parents, because a good butcher knife is such a very handy article around the house. The mother is sure to make plain to the boy how much she appreciates it. And I find that home encouragement and home interest go a long way towards making the boy a good student. Now this is not too hard for the boy to work out, for I am putting it out in a way that any boy in the eighth grade will be able to complete the job with the aid of tools found in every forge equipment. As I have had many years experience in the manufacture of cutlery I realize that none of us are born butcher-knife makers, and right here I wish to make it plain that I am glad to be able to present this article to the forge instructor with the benefit of my many years experience along this line, and if there is any part of the article that is not perfectly plain write me thru the *Manual Training Magazine* and I will gladly set you right.

There are five essential points to start with: first a clean fire with a good bed of coals; second, good cutlery steel; third, careful heating and forging; fourth, hardening and tempering; last but not least, careful grinding.

To make a good butcher knife requires a good grade of cutlery steel this runs high in carbon and low in impurities. The carbon content being from 80 to 100 points, and you will find this listed by the steel manufacturer under Cutlery Steel classification instead of Tool Steel classification. I mention this that you may see there is a marked difference. The steel I use for butcher knives

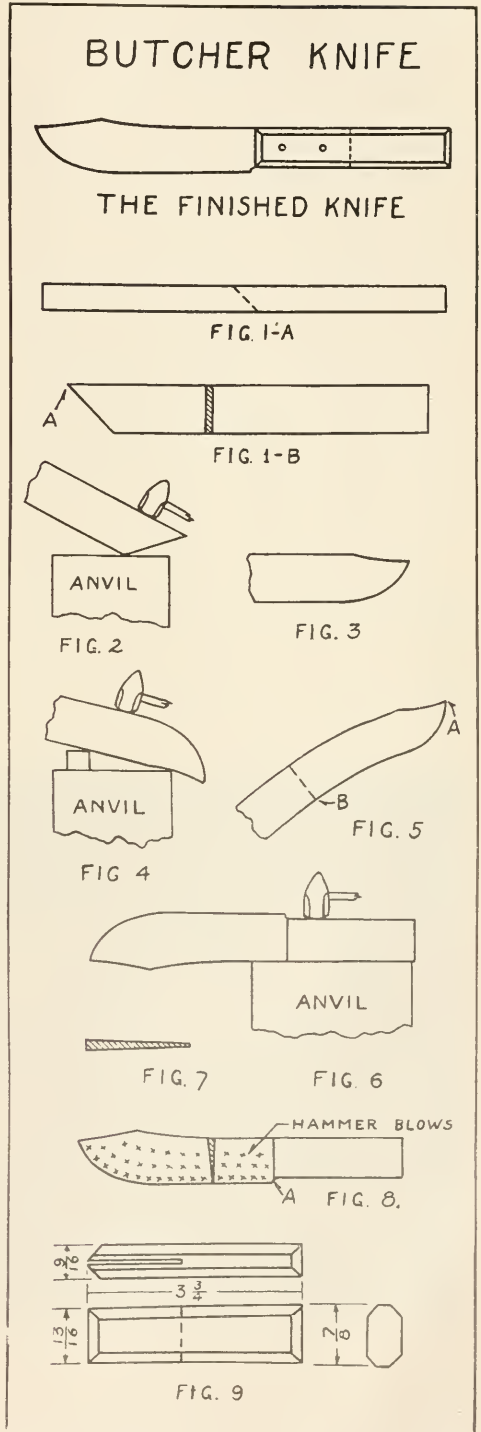

may be purchased from any of the steel companies or steel jobbers. It comes in long bars $7\frac{7}{8} \times \frac{3}{32}$ ". To make a 6" butcher knife from the bar, cut $13\frac{1}{2}$ " then cut this in two in the center on about a 45-degree angle as shown in Fig. 1-A, and each piece will be the same as Fig. 1-B. The price paid for this steel bar per pound is about 20 cents. One end is always cut at the proper angle, as in Fig. 1-B at A. The stock used by cutlery manufacturers for butcher knives, hunting knives, carving and paring knives run in the following sizes; $1" \times \frac{3}{32}$ ", $7\frac{7}{8} \times \frac{3}{32}$ ", $7\frac{7}{8} \times \frac{1}{16}$ " and $\frac{11}{16} \times \frac{1}{16}$ "—the $7\frac{7}{8} \times \frac{3}{32}$ " for butcher knives up to 8", the $1" \times \frac{3}{32}$ " for heavy butcher knives and hunting knives, and the $7\frac{7}{8} \times \frac{1}{16}$ " for carvers. Carving blades are usually 8 and 9" long. The $\frac{11}{16} \times \frac{1}{16}$ " is used for paring knives. By adding the extra length desired to the $13\frac{1}{2}$ " required for two 6" butcher knives will give you the exact length of any blade you care to make. 25 pounds of this steel will keep your boys making butcher knives a long time.

Now to start, we have a piece of steel shaped as in Fig. 1-B. Allow $1\frac{1}{8}$ " from the square end for the shank; the end cut at an angle at A is for the point. First heat the point to a bright cherry red back about $1\frac{1}{4}$ " and forge as in Fig. 2. When properly forged it will look like Fig. 3. After forming this point you will have to forge the flat side to bring the steel back to its original thickness, but keep the same shape as in Fig. 3. You are now ready to curve the steel edgewise. Do this as in Fig. 4. Heat to a bright red, and it should curve as in figure 5. Now you are ready to start forging the blade, generally known as plating by knife makers. You have allowed $1\frac{1}{8}$ " for the shank, the part to go into the handle; start forging at the point marked B, Fig. 5 and strike the blows on the inside of the curve from this place to the point A; reheat, and hammer the other side along the same edge, using the same number of blows, reheating each time, continue this until the edge you are plating is drawn down to about $\frac{3}{2}$ " thickness and your blade has straightened out and looks like Fig. 8. (The above heats should all be at a low cherry red and do not bury up in the fire, but lay on top on a good bed of coals). We are now ready to draw the shank thinner and longer; first forge the shank edgewise until it has decreased in width about $\frac{1}{8}$ "; this is done with the back of the knife lying flat on the face of the anvil. This is to keep the back straight, as in Fig. 6. Now heat and forge the flat sides crosswise of the horn until it has drawn to $13\frac{1}{4}$ " long and is wedge-shape as in Fig. 7. In forging this shank you may heat to a bright red.

Now that we have the forging done we must call

in the help of another boy to strike. With a light sledge, while the blade is being flatted, the blade should be evenly heated to a dull cherry red and flatted on both sides. This will require a heat for each side, and the blows delivered by the striker should be light and fast, and no flattening done after it has reached the black heat. This particular should be closely watched thruout the forging. This flattening should make the blade smooth and straight.

The next operation is shaping, which is generally done on an emery wheel, although it may be done with a file, and by following the lines of Fig. 8 you will have a very good-shaped blade. The shank should be $1\frac{3}{4}$ " long and should be about $\frac{3}{4}$ " wide—a little wider at the end than at A. Now take a squint at the blade and see if it is straight. If not, it may be straightened cold on the face of the anvil with the hammer. Be sure that the hammer face strikes flat down, as the corners will mark the steel.

When straight you are ready to harden. Heat by holding over the fire with the back down. Be sure your fire is clean and as wide as the blade is long, and you may have to move the blade back and forth a little to heat it evenly the full length. Be very particular about this so that the blade is at a *dark cherry red* the full length. Then dip in raw linseed oil down to the shank; hold as nearly perpendicular as possible; keep the shank out of the oil, otherwise you will not be able to drill the holes thru it. After the blade has been in the oil about 30 seconds, remove and clean the oil off by sticking the blade in some ashes or sawdust, and move it around until perfectly clean and all trace of the oil is gone. Then brighten one side of the blade with sandpaper, emery cloth or sandstone. Hold over the fire, about 6" above it, with very little blast, move it back and forth until the color begins to show up on the bright side. You will first notice a straw color, then brass, copper, purple and dark blue: this is the color you want. Then dip it in the oil again, and lay it down to cool. (Dipping in the oil the second time is to stop the temper from drawing any longer. If dipped in water, it would very likely warp). If the temper should draw too fast on one end, hold this away from the fire and the other end over it. By thus moving it around you will be able to get an even color. If it should draw too low, put it back over the fire and heat again, bring it to a *dark cherry red* heat and harden as before. Remember this, as the temper of the blade depends as much on the heat at which it is hardened as on the temper color. If over-heated your color alone will not make a good blade.

The next operation is grinding. Do this on a wet grindstone, and be sure to hold your blade straight across the face of the stone. Do not grind the blade lengthwise, or let it turn cornerwise of the stone; the stone marks should run straight across the blade, and the blade should be rolled just a little towards the edge. (If held perfectly flat on the stone your blade will be hollow ground, and this will make it too thin). Grind until the blade comes just to an edge; any more ground off will throw your blade out of shape.

Now if you have the grinding well done, you are ready for the handle. This should be like Fig. 9. Saw the slot with hack-saw or thin back-saw. This should be $1\frac{3}{4}$ " deep to correspond with the length of shank. Black walnut or beech wood makes a good handle. Do not try to drive the shank in the slot from the end of the handle, but drive it down from the side, and to get it back tight against the end of the slot, strike the base of the handle a few smart blows with a light hammer, this will draw the shank back into the handle. Now mark the place on the handle for the rivets: the first $\frac{1}{2}$ " from the blade, and the other one $\frac{1}{4}$ " from the

bottom of the slot. These should be drilled with $\frac{3}{16}$ " drill; drill clear thru the wood and shank. Cut two rivets from $\frac{1}{8}$ " brass wire (or galvanized wire will do). After you have the rivets in the handle file the ends down so they are about $\frac{1}{32}$ " above the handle on each side, and then head them down with a light ball-peen hammer using light blows. A heavy hammer and heavy blows will bend the rivet and split the handle. Now clamp the handle in a vise, and use a sharp bastard file to cut the handle down to the steel and also to finish the side and the rivets down smooth, and cut the bevels on the handle the same. Sand the wood smooth with fine sandpaper, and polish the blade with emery cloth; this is done lengthwise of the blade. Then hone the edge on an oilstone, the back being raised from the hone about 15 degrees and drawn from the heel to the point. If you have followed this closely you have a very handy butcher knife—one that looks well, balances properly, and will hold a good edge.

—C. O. HUDSON,
Instructor in Forging, South High School,
Grand Rapids, Mich.



BOYS MAKING SMALL FILING CASES, HIGH SCHOOL, DES MOINES, IOWA

CURRENT PUBLICATIONS

Pattern Making. By Joseph A. Shelley, instructor in Pattern Making and Woodworking, member of Pattern Maker's League of North America. Published by The Industrial Press New York, 1920. Size 6 x 9 in.; 342 pages; price \$3.00.

This book, in sixteen richly illustrated chapters, deals with all phases of wood pattern making. The principles of molding, insofar as they are related to pattern making have been covered in detail. Particular stress is laid on the fundamental principles and processes involved in the construction of a number of patterns of the common type. Specific information is given about the different machines employed in pattern making and definite instruction is supplied for their operation. The last chapter is devoted to filing and setting of hand and machine saws.

While the book is primarily written for the persons who are interested in pattern making as a vocation it should prove to be a valuable treatise for draftsmen who are concerned with problems, the solution of which necessitates a knowledge of the pattern maker's trade.

Industrial Mathematics. By Paul V. Farnsworth, formerly supervisor of the Cadillac School of Applied Mechanics. Published by D. Van Nostrand Co., New York, 1921. Size 5 x 7½ in.; 274 pages; 250 illustrations; price \$2.50.

This book, which is designed as an instruction and reference book for students in manual training, industrial and technical schools, and for home study, has back of it many years experience by the author as supervisor of apprentices, shop foreman, and instructor in evening classes and technical schools. It is a combination of the common principles of mathematics into one volume in a practical relation to the various forms of shop work.

The fundamental operation in arithmetic, algebraic expressions and formulas, and trigonometric functions, are treated in a practical manner in this book, and applied to problems which naturally arise in the shop. Problems related to levers, pulleys, gears, and drives, strength of material, cutting speeds, the steam engine, electricity, etc. are offered in abundance.

Preparatory Mathematics for use in Technical Schools. By Harold B. Ray and Arnold V. Doub, teachers of mathematics, Cass Technical High School, Detroit, Michigan. Published by John Wiley and Sons, New York, 1921. 4¾ x 7 in. 68 pages; illustrated, price \$1.00.

This book, which is one of the Cass Technical High School Series, is planned particularly for students who wish to enter technical courses in part-time or all day trade classes, and who find themselves deficient in the knowledge of the funda-

mentals of mathematics. These fundamental operations are treated in a concise and yet thoro manner in this volume. Definite application is made to concrete problems of the shop while sufficient drill is suggested to make the student prepared for more advanced work in mathematics. The material and method used in this text have been tried thoroly by the authors with the type of students for which the book is written, and each problem or exercise has proved its value as a piece of useful, necessary information in preliminary mathematics for the class of students which the book is prepared to serve.

The Junior High School. By Thomas H. Briggs, Professor of Education, Teachers College, Columbia University. Published by Houghton Mifflin Co., Boston. Size 5 x 7½ in.; 350 pages; price \$2.25.

The author has been for many years one of the leaders in the development of the junior high school, but his attitude is that of a scientific student of education rather than of a propagandist. He regards the junior high school as an aid in vocational guidance rather than as a trade or college preparatory school. The junior high school has obtained the recognition of educators and public. This book discusses the aim of the junior high school, and gives data and constructive suggestions concerning organization, curricula, methods of teaching, teachers and salaries, administration of schedule, social organization and control, buildings and grounds, maintenance and costs, self-government, educational and vocational guidance, in a sane and practical way which will be appreciated by all who are confronted with the problem of organizing a public school system.

RECEIVED

Bulletin of The Western Art Association. Proceedings of Meeting held at Detroit, Michigan, May 4 to May 7, 1920. Published by the Association, at 234 Division Avenue, N., Grand Rapids, Michigan.

Physical Standards for Working Children. Issued by United States Department of Labor, Childrens Bureau, Julia C. Lathrop, Chief. Bureau Publication No. 79.

Bulletin of the American School. A monthly publication by the American School, Dresdel Avenue and 58th Street, Chicago.

Report of Committee on Teaching Social Science in High Schools. By Ruth Mary Weeks, John R. Commons, and Frank M. Leavitt. The first of a series of monographs on vocational education published by The Vocational Education Association of the Middle West.

You don't need 3 hands with this bench drill

One hand to hold the work on the table—the other to turn the crank! You don't need a third hand to feed the drill to the work, as with ordinary bench drills.

The "Yankee" Friction and Ratchet Feed automatically takes care of the feeding. The pressure is automatically regulated for all drills—from the smallest up. You don't have to adjust it or even think of it.

It's the only bench drill of the kind in existence. A remarkable saver of time, labor and DRILLS.

The drill is run rapidly down to the work by the *friction feed* then the *ratchet feed* goes into operation. Turn the crank and watch the work—that's all.

The "Yankee" Chain Drill has the same friction and ratchet feed.

*Dealers everywhere sell
"Yankee" Tools*

Some other "Yankee" Tools

- Spiral Screw-drivers
- Ratchet Screw-drivers
- Plain Screw-drivers,
1½ to 3 0 in. blades
- Ratchet Chain Drills
- Ratchet Hand Drills
- Ratchet Breast Drills
- Automatic Push Drills
- Ratchet Tap Wrenches
- Bench Vises, removable base

Write today for this interesting and instructive tool book



Contains over a hundred illustrations showing how simply jobs can be done with the right tools. Mailed FREE.

NORTH BROS. MFG. Co.
Philadelphia

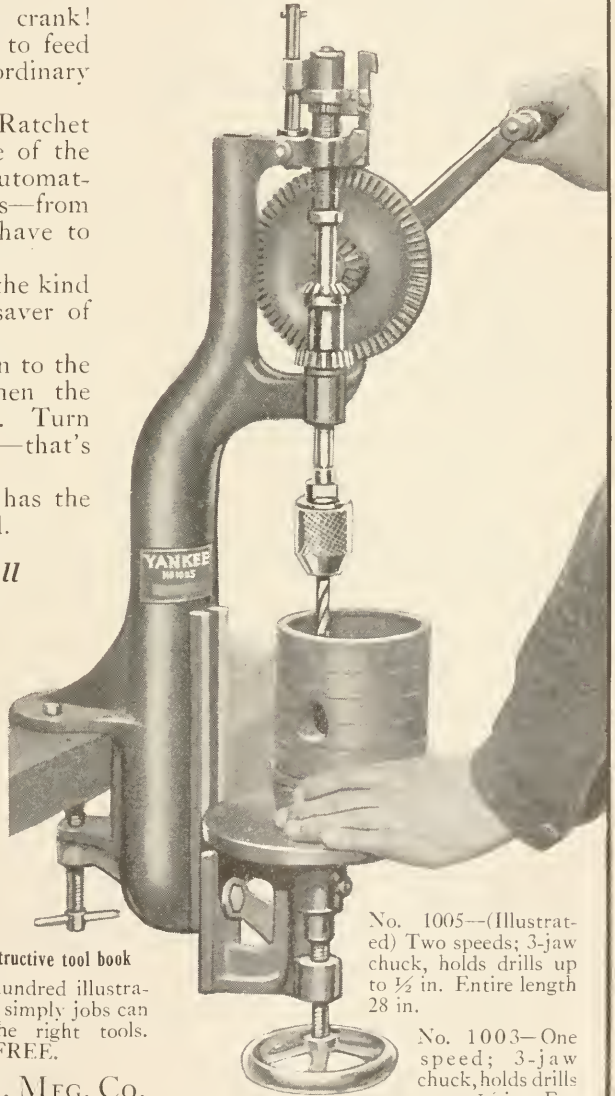

No. 1005—(Illustrated) Two speeds; 3-jaw chuck, holds drills up to ½ in. Entire length 28 in.

No. 1003—One speed; 3-jaw chuck, holds drills up to ¼ in. Entire length 18¾ in.

"YANKEE" TOOLS

Make Better mechanics

We are Pleased to Announce Our

SEVENTH ANNUAL CATALOG

“Hard-to-Get” Materials

Ready for Distribution Now

This Catalog will be mailed free to any
Manual Training Instructor

We place these materials on the market expressly for Manual Training Departments and thousands of Instructors in all parts of the country are familiar with our line. Below is a list showing some of the items we handle. Check this over and note the number of articles you have at some time, had difficulty in obtaining or perhaps been unable to get at all.

UPHOLSTERY SUPPLIES—Leathers and imitations, tapestry, gimps, nails, springs, webbing, cotton, tow, moss, etc. Cushions made to order exactly to fit your project, any size or style.

CHEST TRIMMING—Solid copper bands and cut designs, coppered locks, nails, hinges, handles cover supports, etc., also trimmings in hammered old copper effect, corners, hinge plates, handles, etc.

TEA WAGON WHEELS—In both oak and gum complete with rubber tires and axle. Also tea wagon casters and tray handles.

SMOKING STAND TRIMMINGS—Brass and glass trays, brass match box holders, and cigar rests.

WOOD LAMP SHADES—For electric lamps, in either oak or solid walnut complete with art glass. Also art glass cut to size to fit your own shades.

ATTRACTIVE CABINET HARDWARE—Period and mission pulls, wood knobs, costumer hooks, small box trimmings, brass leg sockets, label holder pulls, etc., etc.

ODDS AND ENDS—Porch swing chains, extension table slides, wood dowels 3-16" to 1", steel rails for wood beds, typewriter desk attachments, mirrors, chair cane, etc.

Stanley Tools Dennison Glue
Johnson's Stains

Write today for this new catalog

Thurston Manual Training
Supply Co.

Jobbers and Manufacturers

ANOKA,

MINNESOTA

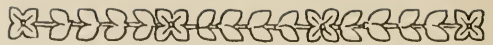

FIELD NOTES—(Continued)

the war service, has accepted a position as teacher of manual training in Logan, West Virginia.

MR. McELROY, who has been head of the manual arts work at Warrensburg Normal School, Warrensburg, Missouri, has accepted the position as supervisor of manual training in the public schools of Okmulgee, Oklahoma.

MILES H. RODGERS, who was formerly a teacher of manual training in Middletown, Ohio, and who at one time taught iron work and mathematics in Straight University, New Orleans, has been appointed to a position as teacher of manual training in Cambridge, Idaho.

FREDERICK H. EVANS of Toledo, Ohio, is again returning to educational work in the U. S. Army. At least, he is giving part of his time to such work. He is now a member of the General Staff Advisory Board, War Plans Division, War Department. He is continuing the work started by the Advisory Board during the war. For the present he will divide his time between this government work and his work in Toledo as consulting engineer.

J. C. DOUGHTIT who was one of the teachers of auto-mechanics in the high school of Okmulgee, Oklahoma last year has resigned, and also severed his connections with the teaching profession. He now operates a battery service station in Okmulgee. The vacancy made by Mr. Doughtit's resignation has been filled by Mr. Morehouse who is an electrical engineering graduate of Purdue University.

HENRY F. HOLTZCLAW, who has held the position of State Supervisor of Trade and Industrial Education in Oklahoma in connection with the State Board for Vocational Education has tendered his resignations to the Board and has accepted the position of Dean of the School of Commerce and Marketing, Oklahoma Agricultural and Mechanical College, Stillwater, Oklahoma.

“MEET ME IN MILWAUKEE
IN MID-WINTER”

THE above is the slogan which the Vocational Education Association of the Middle West has adopted for its convention next January. The dates as recently announced are January 11, 12, 13, and 14, 1922.

TOOLS

For Manual Training Shops.
Send your inquiries to and get the especially
low prices quoted by

MONTGOMERY & CO. Inc.,
105 Fulton Street New York City

Don't let Your Boy Say
"I never had a Chance"

Fifteen minutes a day reading one or more of the hundreds of educational subjects found in Nelson's Perpetual Loose-Leaf Encyclopaedia is equal to a liberal education. This great American Reference Book is a complete and practical college education in the home.

Form the habit—15 minutes a day with Nelson's

NELSON'S

Perpetual Loose-Leaf

ENCYCLOPÆDIA

and Research Bureau for Special Information

The Schoolmaster for the whole Family

Thousands of letters are received from satisfied subscribers. Mr. Clarence R. Wise, Dept. of Chemistry University of Wisconsin, writes: "I am living in a fraternity house, and of course many deep questions arise. Only yesterday we got into a discussion as to the time of the building of King Solomon's Temple. Of course, I found it in Nelson's. I am very glad I made the purchase. I think that every man who has a home, or intends having one, should feel that it is not complete until he has in his possession a set of Nelson's Perpetual Loose-Leaf Encyclopaedia. It is certainly a wonderful asset. All that has been said of Nelson's is certainly true."

A New World demands—A new Encyclopaedia

The Great War has turned the attention of most people to the greater necessity of education. You cannot stop with the education you received in school or even in college. You must continue to keep up with the activities and progress of the NEW WORLD. This has necessitated a new Encyclopaedia.

Nelson's Patent Loose-Leaf Binding Device has solved the problem. Every six months the subscribers to Nelson's receive their Renewal Pages—250 Pages or more, making 500 to 600 Pages each year. These include over 2,000 changes absolutely necessary to keep Nelson's perpetually accurate and in step with the NEW WORLD.

Save Time—Look It Up In Nelson's!

Nelson's Reading and Study Courses in UNITED STATES HISTORY, BUSINESS ECONOMICS, NATURE STUDY, AGRICULTURE, AND HOME ECONOMICS are declared by educational authorities to be equal to a college course and training in each of these departments. By their use a boy can remain on the farm and yet receive all the advantages of a college course in Scientific Farming; a girl may have the services of the leading authorities on household economics without leaving her home; while the professional and business man may receive a business training superior to that which can be obtained from any of the widely advertised business institutes.

EXCHANGE Send for price list giving amounts allowed for old Encyclopaedias to apply as part payment on a new Nelson's Perpetual Loose-Leaf Encyclopaedia.

THOMAS NELSON & SONS

381 Fourth Avenue, at 27th Street, New York
177 Wellington St., West
Originators of the Loose-Leaf Reference System

Nelson's Research Service Bureau

FOR SCIENTIFIC REPORTS AND SPECIAL INFORMATION AND CORRESPONDENCE. Every purchaser of Nelson's is entitled to free membership in this Bureau. If at any time you are in doubt on any subject, old or new, write to this Bureau with the positive assurance that you will promptly receive the latest obtainable and most dependable information.

Send for this Splendid Book

THOMAS NELSON & SONS
Publishers for 120 Years

Dept. 252 381 Fourth Avenue, New York City

Please send me your portfolio of sample pages—beautifully illustrated, containing color maps, plates and photographs, and full information how by easy monthly payments I can own Nelson's Perpetual Loose-Leaf Encyclopaedia and receive FREE membership in Nelson's Research Service Bureau for Special information. This must incur no obligation whatever on my part.

Name

Address

City State

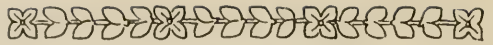

FIELD NOTES—(Continued)

The secretary has just issued the *Mid-West Bulletin*, eighth year, number one, which announces the various committees and gives information regarding the work of the association. The annual convention of this association is a four day "post graduate extension course" for all who are actively engaged in any form of vocational education. Besides the opportunity to meet just about everybody who is worth while in vocational education in the Middle West the program of the convention is the place where all the committee reports are presented and discussed. These reports represent serious work covering an extended period of time by groups of people interested in various phases of vocational education. After discussion in open meeting many of these reports are published. The publication committee of which Chas. A. Bennett is chairman, has just issued "Monograph No. 1—Series 1921" which is a report of the social science committee and represents investigation and work covering a period of three years. This report presents a plea for a study of social sciences in the high school and the industrial classes. It is a pamphlet of thirty pages and includes besides a suggested series of lessons a very valuable bibliography. This monograph is sent free to members. To others the price is twenty cents per copy. The quality of this report may be judged from the membership of the committee which was composed of Ruth Mary Weeks, chairman, Prof. John R. Commons of the University of Wisconsin and Frank M. Leavitt, Assistant Superintendent of Public Schools, Pittsburgh. Many others collaborated with the committee in testing out the lessons as suggested. This report represents a distinct addition to the literature of vocational education. The publication committee expects to announce future issues of this series of monographs in rapid succession.

The Milwaukee meeting will see the results of several committees presented in the form of reports. Last year at the Minneapolis meeting agricultural education was given considerable impetus by the particularly strong sectional meetings which brought together experts in this line from all over the Middle West. The present committee of which Prof. F. W. Stewart, professor of agricultural education, University of Ohio, is chairman will show excellent results in following up the good work begun in Minneapolis.

For several years commercial education has had a prominent place on the program. C. M. Yoder state supervisor of commercial education in the state of Wisconsin is chairman of the committee,

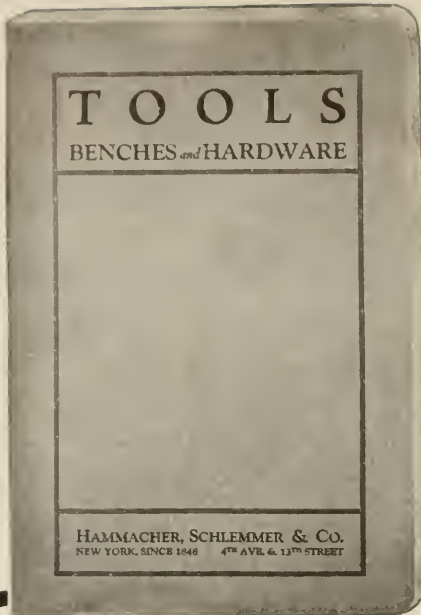

GOOD TOOLS ARE ESSENTIAL FOR GOOD WORK

Since 1848 we have adhered to one policy—to handle only the very best in quality.

Our 300 page catalog illustrated above is of particular value to those interested in manual or vocational training. If you haven't a copy ask for Catalog No. 224.

**HAMMACHER
SCHLEMMER & CO.**
Hardware, Tools and Supplies
New York, Since 1848, 4th Ave. and 13th St.



An ELDORADO pencil in hand, and your pupil realizes the result is strictly up to *him*—for “the master drawing pencil” is as responsive and dependable in his hand as in the hand of a master.

DIXON'S ELDORADO

“the master drawing pencil”

SAMPLE OFFER TO TEACHERS

Dixon's Eldorado is made in 17 Leads. Tell us whether you teach mechanical or freehand drawing and we will mail you suitable samples.

Joseph Dixon Crucible Company

Pencil Dept. 19 J Jersey City, N. J.

CARPENTRY BY GRIFFITH

The one text book on carpentry for use by trade apprentices, students in vocational and trade schools and students of manual arts



CARPENTRY is a treatise of the “every-day” problems of the carpenter and house builder. Unlike other books on the subject, it does not deal with miniature models or a few selected details, but treats of the practical problems of the carpenter from the “laying of Foundations” to the completion of the “interior finish.”

It meets every student requirement. Well illustrated with photographs made by an expert taken “on the job.” Price, \$1.70. Discount in Quantities.

THE MANUAL ARTS PRESS, PEORIA, ILLINOIS

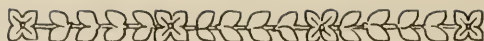

FIELD NOTES—(Continued)

Redwood Provides Perfect Gluing Surfaces

The uniform cell structure of Redwood gives it a remarkably even texture—surfaces that give glue countless anchorages, that also permit of an attractive wax, varnish or paint finish. Besides being light in weight, soft and odorless, Redwood is insect and vermin proof. Properly cured it does not shrink, warp nor swell.

Largely used for incubators, screen frames, clothing chests and shirtwaist boxes, for cigar and candy boxes, bird houses, etc., and for storage battery separators.

Vertical grain up to 12" wide—slash grain any desired width. thicknesses—3/16" and up.

Samples of Redwood in various thicknesses, both slash and vertical grain will be gladly sent to manual training instructors on request.

and promises some interesting results of investigations and study.

The discussion on vocational guidance at Minneapolis rivalled the famous discussions on Article X on the League of Nations. Under Harry D. Kitson, professor of psychology of the University of Indiana as chairman, the committee will be prepared to "meet all comers" at the Milwaukee meeting.

Miss Elizabeth Fish of the Girls Vocational School, Minneapolis is chairman of a special committee dealing with "Women in Industry." This will be a valuable report and will summarize investigations covering several years of study.

W. F. Faulkes, state supervisor of trades and industries is chairman of the committee on industrial education which may be expected to contribute valuable data on part-time education.

The home economics committee has for several years been engaged in important investigations, and under the leadership of Martha A. French, director of the household arts department of the State Normal School, Ypsilanti, Mich., this committee may be relied upon to contribute a valuable report.

Until there is the committee on membership. Everyone who has ever attended a convention of this association is a decided booster. Send to the secretary, Leonard W. Wahlstrom, 1711 Estes Ave., Chicago, the names of all persons in your community who should receive bulletins and who should be

Enamelac

The New Decorative Art Enamel



Makes Things Beautiful

"Enamelac" is revolutionizing Decorative Design. It is **waterproof**—works on any surface except paper—and dries over night. Used to decorate Toys, Jewelry, Wooden Boxes, Frames, Bottles, etc. Let your pupils make useful things beautiful. "Complete Outfit" 6 cans "Enamelac," 3 Brushes, Shellac and Turp. in box, postpaid \$3.00. Per can 30c. **Circulars free.**

THE PRANG COMPANY
1922 Calumet Ave., CHICAGO



2090 McCormick Bldg., Chicago
New York Kansas City

THE PACIFIC LUMBER CO.
San Francisco Los Angeles

EXPORT COMPANY:
A. F. THANE & CO.

233 Broadway, New York City
311 California Street, San Francisco

*The Largest Manufacturers and Distributors of
California Redwood.*

Members of the California Redwood Association

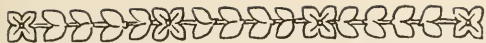

FIELD NOTES—(Continued)

members. A dollar bill pays for a year's membership and will bring by return mail a copy of the report mentioned above, as well as future issues of the Bulletin and the monographs as issued during the year.

"Meet Me in Milwaukee in Mid-Winter."

—L. W. WALSTROM.

PROFESSOR M. L. NICHOLS, head of the Department of Agricultural Engineering, assisted by thirty instructors, taught the care and management of planters, harvesters, seed drills, plows, cultivators, and the operation and management of tractors to the Alabama club boys at their annual encampment at Auburn, July 25-30. Special lectures and demonstrations of the management of gas engines were given, and the carpentry work consisted of gate-making and fencing. Several large companies put on a display of farm machinery and home conveniences.

A NEW HIGH-SCHOOL building is being constructed in Lowell, Wyoming. Lowell now offers courses in vocational agriculture and vocational home economics in addition to general shop work for the seventh and eighth grade boys. I. W. Harmon is in charge of the work in the shops.

UNIQUE PLAN FOR FINANCING A STATE SCHOOL

IN THE American Trust Bank Building in Birmingham, Alabama, headquarters have been opened for receiving donations of \$1.00 each from the people of the state, to the amount of \$30,000 to match an equal amount offered by the state for the establishment of the Alabama School of Trades and Industries. The state now owns a site for this school consisting of 100 acres of land located

PRACTICAL VOCATIONAL TEXTBOOKS

PUBLISHED BY

JOHN WILEY & SONS, Inc.

The Wiley Technical Series is a special series of practical vocational texts written under the editorship of Joseph M. Jameson, Vice-President of Girard College, Philadelphia. Every book in this Series is intensely practical and presents its subject in a clear and logical way. It includes books that are in wide use in vocational instruction throughout the country.

Wiley Vocational Texts Cover

- AGRICULTURE
ARCHITECTURE
AUTOMOBILE WORK
CARPENTRY
CHEMISTRY
COSTUME DESIGN
DECORATIVE DESIGN
DRAFTING
ELECTRICITY
FORGING
GEOGRAPHY
HEAT
MACHINE DESIGN
MACHINE SHOP PRACTICE
MATHEMATICS
MECHANICS
(Elementary and Advanced)
PATTERN MAKING
PRINTING
STEAM POWER
AND POWER PLANTS
STRENGTH OF MATERIALS
WELDING

If you teach or are interested in any of the above subjects, do not miss seeing some of these Wiley Texts, for they are PROVEN successes. Copies of books on any of the above subjects will be sent to you on Free Examination. Mail the coupon today.

USE THIS COUPON

John Wiley & Sons, Inc., 432 Fourth Avenue, New York City. You may send me the following on 10 days' approval:

.....
.....
.....

I agree to pay for the books or return them within 10 days of receipt.

Also please send me a copy of your Vocational News and put my name on your mailing list.

Name

Address

If teacher, state school.....

If not teacher, give reference.....

M.T.M. 10-21

Build Your Own PHONOGRAPH

Instructive—arouses pupils enthusiasm—provides one of the best problems in cabinet making.

Let Your Pupils Build Choraleon Phonographs

We furnish plans, blue prints, motors, tone arms, case material—in fact, everything required. Full instructions. Choraleon's have fine tone. Play any record. Ask for particulars.



CHORALEON PHONOGRAPH CO. 1021 7th St., Elkhart Ind.



Tool Processes in Wood Working

By A. P. LAUGHLIN
Senn High School, Chicago

A MODERN TEXTBOOK for Grammar
Grade Classes—

Gives all that the boy needs to know in
order to do intelligent work with the usual
woodworkers tools.

Greatly enriches the thot content by sug-
gesting references and experimental work.

Provides for the inattentive boy, the slow
boy, the boy who has been absent, and also
the boy of marked ability.

The arrangement of type and the para-
graphing is a feature of special value.

Enthusiastically endorsed by many users.

Price, 88 cents

The Manual Arts Press
Peoria, Illinois

at Ragland, and has appropriated a maintenance fund for the school, and \$30,000 to be used in the erection of the first building provided that the people of Alabama will match the latter with an equal sum.

The unique plan of asking for a large number of very small donations instead of soliciting large sums from only a few people is expected to serve as an educational campaign within the state, and to cause the public in general to feel a certain ownership in the school after it is established.

Great interest has been manifest toward the project. Even before the formal opening of the campaign hundreds of donations were received by the committee in charge. Dr. Abercrombie, state superintendent of education, Dr. Denny, president of the state university, and Dr. Dowell, president of Auburn, have given their support to this movement, pointing out that there is a distinct need for this school to give training to the large number of young men whose preparation for an occupation is such that it does not fall within the scope of the courses offered in any state institution at the present time.

The Exchange Clubs of Alabama, and a number of other organizations of a statewide scope, have combined their influence to make this drive a success. Confidence is expressed that the total amount needed will be obtained within sixty days.

EXAMINATIONS FOR ASSISTANTS IN REHABILITATION

EXAMINATIONS for reconstruction assistants in physiotherapy and occupational therapy have been announced by the U. S. Civil Service Commission. The work in occupational therapy involves toy making, reed and raffia work, chair caning, wood-carving, jewelry, bookbinding, etc. That of physiotherapy consists largely of gymnastics, massage, hydrotherapy, etc. The examination may be taken by correspondence. It is open to anyone between the ages of twenty-one and seventy, who is a citizen of the U. S. or a citizen of an allied country or one which was neutral during the war. Further information regarding these examinations may be had by applying to the U. S. Civil Service Commission, Washington, D. C.

ITEMS OF PROGRESS

CARPENTRY CLASS WILL BUILD BUNGALOW

A BUNGALOW at the estimated cost of \$3,000 will be built this year by the carpentry students of the Smith school of Northampton, Massachusetts. An agreement has been made with a

**Specialists in
Manual Training Lumber**

**Maisey & Dion
Hardwoods**
KILN DRIED AND AIR DRIED
OFFICE & YARDS 2349 TO 2423 So. LOOMIS ST.
TELEPHONES
CANAL 1830
CANAL 1831
CANAL 118

**CHICAGO
THE
Great Central Market**

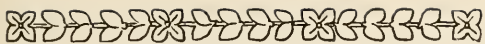

FIELD NOTES—(Continued)

private person for the construction of this house. While the carpentry department has done much productive work for the school in the past, this is the first time that an outside contract has been taken. The work will be done under the supervision of M. Eugene Smith, who is head of this department.

INDUSTRIAL ARTS YEARBOOK

Industrial Arts Yearbook of the Industrial Arts Club, Oregon Agricultural College, Corvallis, Oregon, has been published. It contains illustrated articles on the opportunities of the industrial arts teacher. Blacksmithing, foundry practice, auto mechanics, phonograph construction, machine shop work, and other activities of the Industrial Arts Department are included. This department is directed by Prof. H. E. Brandon, and is included in the School of Engineering and Mechanic Arts.

WHEN CLASSES ARE FULL

Many applications of students for entrance to the trade school of Westfield, Massachusetts, have had to be turned down on account of limited room and equipment. A considerable time before the beginning of school there were forty applications

PUPILS SHOP ACCOUNTS

do Not Trouble Instructors Using Our Systems. Pupils do all the Recording Accurately and "to date." All Accounts are Kept

AUTOMATICALLY

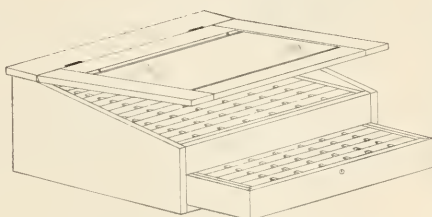

One of our Many Designs of the Industrial Arts Record. Built to Handle Any Number of Pupils.

Priced \$15 to \$85 with Liberal Discount in Quantities.

Let your problem be our burden

MANUAL ARTS SPECIALTY CO.

"Makers of Shop Efficiency"
ATCHISON, KANSAS

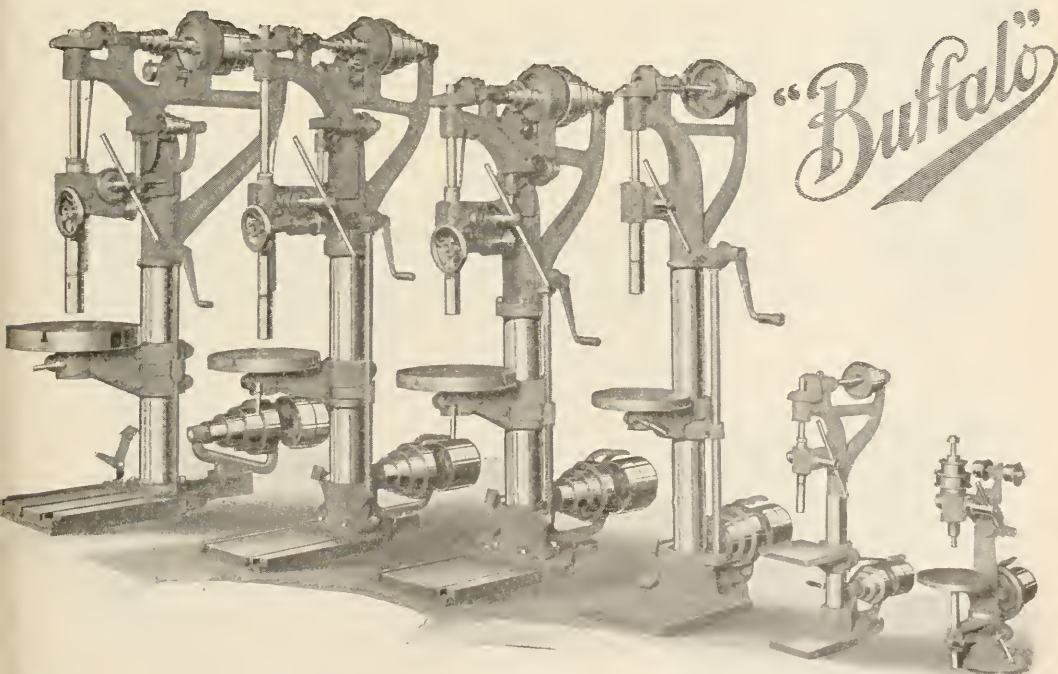

The complete Buffalo drill line includes 25", 20", 15", 10", 10" Jr. Each drill is a worthy addition to the Buffalo line of machine tools. Dept. 31 will send you catalogue giving complete information.

BUFFALO FORGE COMPANY, Buffalo, New York



NEW
No. 65 **LUFKIN** "UNIVERSAL" TRY
AND MITRE
SQUARE
HIGH GRADE YET POPULAR PRICED.
ACCURATE—DURABLE—WELL DESIGNED.

9-inch \$1.75
12-inch \$2.00

Distinct marking; movable yet secure head. Serves also as marking, height and depth gauge, and separate rule. *If Unobtainable at Dealers Write Us Direct.*

Send for Catalogue

THE LUFKIN RULE CO.

SAGINAW, MICH.
New York

VENUS PENCILS

*The largest selling Quality
pencil in the world*



For high lights and deep shadows, for quick or detail sketching, for smoothness and accuracy, the famous VENUS pencils are unexcelled.

17 black degrees. 3 copying

For bold heavy lines
6B-5B-4B-3B

For general writing and sketching
2B-B-HB-F-H

For clean fine lines
2H-3H-4H-5H-6H

For delicate thin lines
7H-8H-9H

Plain Ends, per doz., \$1.00

Rubber Ends, per doz., 1.20

*At Stationers and Stores
throughout the world.*

American Lead Pencil Co.

219 Fifth Ave. (Dept. A) N. Y.
also London, Eng.

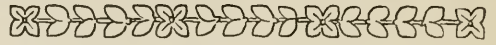

FIELD NOTES—(Continued)

at hand with only fourteen places open. Efforts have been made from time to time to increase the facilities so that a larger number of students could be taken care of. C. C. Darby, the director, has recommended that other technical courses which could be given with a minimum additional equipment, and yet would give the opportunity for a technical education, be offered to the boys who are now being turned away.

SCHOOLS TO PRODUCE FURNITURE

A large output of school furniture is being produced by the Vocational School and the manual training department of the Cherry Street school in Elizabeth, New Jersey. Sixteen double drawing desks, each having compartments for twelve drawing boards; two large tables for use in general science having six drawers with lockers below; twenty-four kindergarten tables; and six other class room tables are among the articles which have been produced or are under construction.

TO EXHIBIT PUPIL'S HANDICRAFT

The Pan-Pacific Union is an organization which has for its purpose a greater co-operation among and between the people of all races in Pacific lands.



ORDER NOW—DIRECT FROM US

Mechanical Drawing Instruments

AT OUR ATTRACTIVE WHOLESALE PRICES
AND SAVE ONE-HALF OF RETAIL PRICES

Set of Instruments as per Photo \$5.50

Construction of Solid Nickel Silver and Steel—Pocket Case 8½ Inches by 4 Inches, and Lined with Velvet.

A Set of Instruments Every Manual Training Student Can Afford—at a Big Saving and Perfect Satisfaction

Send for Catalog on Other Sets, Etc.

National Instrument Company

4700 North Hamilton Ave., Dept. M., Chicago, Ill., U. S. A.

Correlated Courses in Woodwork and Mechanical Drawing

By IRA S. GRIFFITH

Professor of Industrial Education, University of Wisconsin

A manual training teacher's every-day helper. It was designed to meet the needs of the teacher of wood-working and mechanical drawing for reliable information concerning organization of courses, subject-matter and methods of teaching. It covers classification and arrangement of tool operations for grades 7, 8, 9 and 10, shop organization, allotment of time, design, shop excursions, stock bills, cost of material, records, shop conduct, the lesson, maintenance, equipment, and lesson outlines for grammar and high schools. In fact it is the most comprehensive treatment of the subject of teaching woodworking ever published. The author is an expert workman who has been a successful teacher and supervisor of public school manual training. It is based on sound pedagogy, thoro technical knowledge and successful teaching experience. *Contains 100 full-page plates of working drawings of successful projects.* PRICE \$2.50.

IT IS PRACTICAL
THE MANUAL ARTS PRESS
PEORIA, ILLINOIS

The Student Needs Printing

as much as he needs the alphabet

Q It is as much a part of Education as English, the Rule of Three and History. It is, in fact, a combination of all studies—a practical illustration of all the student learns from teachers and books. It is at once a science, an art and an occupation. It gives him manual, mental and moral training. It helps him form habits of industry, accuracy and taste. It is a joy to the learner and a splendid asset in every relation of life.

Q We supply printing outfits for schools, and give the benefit of our experience and that of schools which have tried out the plan. No school is complete and doing its best work, or near its best work, unless printing is a part of its equipment.

Q Send to us for help in your problem.



Barnhart Brothers & Spindler

Type Founders

Chicago Washington, D.C. Dallas Saint Louis
Kansas City Omaha Saint Paul Seattle

SIDNEY ENGINE LATHES

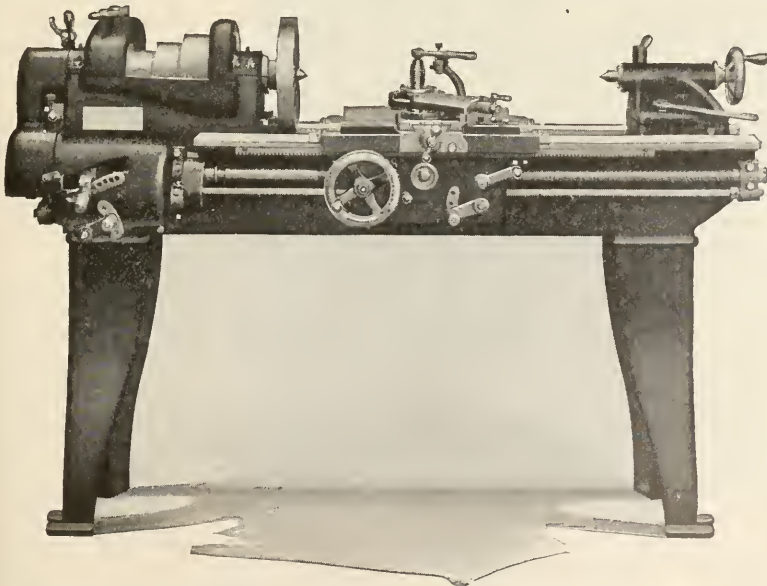

10 to 36"
Swing
Universally
Used for
Vocational
Schools.

Interesting
Descriptive
Matter Free
to
Educators.

Complete
with
all Modern
Features
and
Equipment.

THE SIDNEY MACHINE TOOL CO. Sidney, Ohio

SAW TABLES

For MANUAL TRAINING

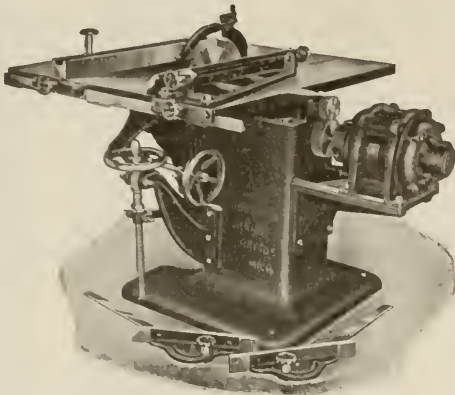

This cut shows our motor driven spiral gear saw table. No countershaft, no belts. Tilting or stationary tops. Write for circular and prices on our entire line. Address

ALEXANDER DODDS CO.

451-453 Monroe Ave., N.W.

GRAND RAPIDS, MICHIGAN, U. S. A.



FIELD NOTES—(Continued)

One of its many objects is "to promote and conduct a pan-Pacific exposition of handicrafts of the Pacific people, of their work of art, and scenic dioramas of the most beautiful bits of Pacific lands, or illustrating great Pacific industries." The central office of this union is at Honolulu.

TRADE EDUCATION IN CONNECTICUT

The trade schools in Connecticut have prepared for a greatly increased enrollment this year. The trade school department is engaged in starting a continuation school system in New Haven in cooperation with local manufacturers. Three hundred ex-service men are being educated in the different schools of the state. Trade schools are located in the following communities in Connecticut: New Britain, Meriden, Torrington, Danbury, Kent, Bridgeport, and Stamford.

COURSES EXTENDED IN NEW ORLEANS

The city of New Orleans has enlarged the scope of its manual training work for the year. Five new teachers have been employed for the new courses. The serving of lunch to school children,

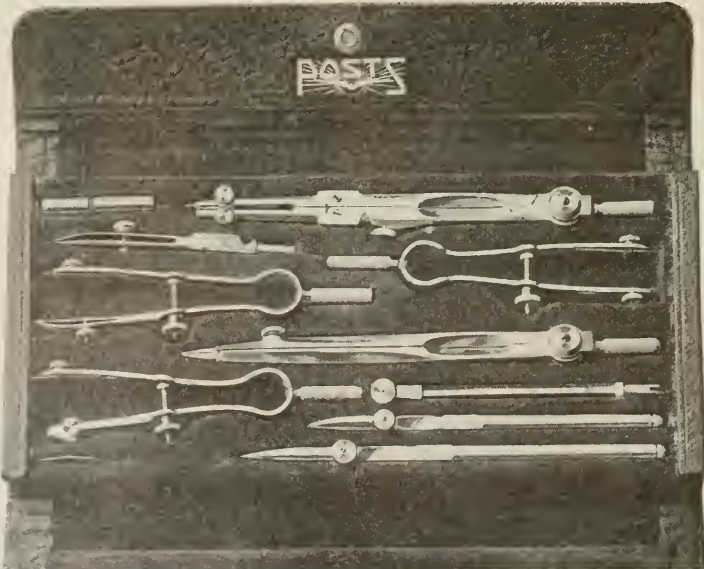

Special Offer

Unusual Bargain

No. 1070C Set in Case Ruling Pen Compass, **\$2.50.**

No. 1071½C Set in Case Ruling Pen, Bow Pen, Hair-spring Divider Compass, **\$3.00.**

No. 1073C Set in Case Ruling Pen, Bow Pencil, Bow Pen, Hair-spring Divider Compass, **\$4.**

No. 1075C Set in Case Ruling Pen, 4½", Ruling Pen 5½", Bow Divider, Bow Pencil, Bow Pen, Hair-spring Divider Compass, **\$5.**

POST PAID

LIMITED QUANTITY FOR IMMEDIATE ORDER ONLY

THE FREDERICK POST CO.

Salesrooms
319 S. Wabash Avenue.

CHICAGO

Main Office and Factory
Irving Park Station

Lumber

All Kinds of Domestic and Foreign Woods.

Send for New Catalogue and Price List.

Frank Paxton Lumber Co.
Kansas City, Kansas

CABINET CLAMPS

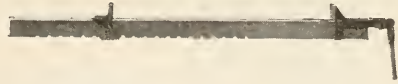

Where Black Bros. Clamps are known there is no Second Choice.

KNOW THEM
Send for bulletin today.

THE BLACK BROS. CO.
Mendota, Ill.

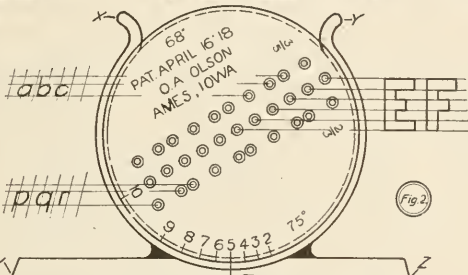

AMES LETTERING INSTRUMENT

It's the only instrument of its kind that allows the user to vary the heights of lettering by adjustment of the dial or disc. Slope lines can be drawn without any adjustment of parts.

6000 NOW IN USE

It is the only instrument of its kind that has holes spaced for three different systems of guide lines.

THE O. A. OLSON MFG. CO.
Ames, Iowa

Can be used on Tee Square, Straight Edge or Triangle.

Dealers wanted in every city. Write for prices.

"STAR" LATHES

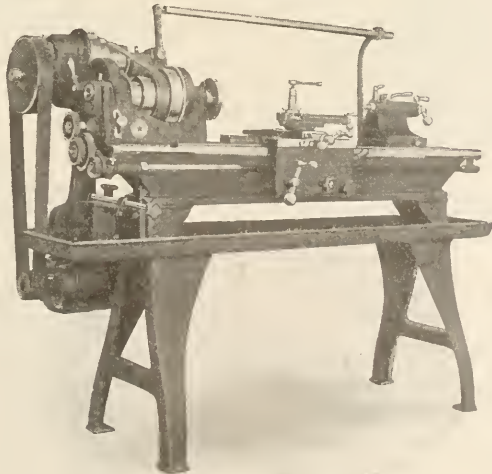

9" x 4' MOTOR DRIVEN LATHE

"Over One Million "Star" Lathes in Fifty Years—Why? Ask the User"

THE SENECA FALLS MFG. CO., Inc.
SENECA FALLS, N. Y.



"JORGENSEN" PEERLESS HAND SCREWS

A single clamp will adjust to any of these positions or any modification of them.

Steel Spindles
Steel Nuts
Hard Maple Jaws

**Adjustable
Clamp Co.**

216 N. Jefferson St., Chicago

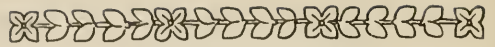
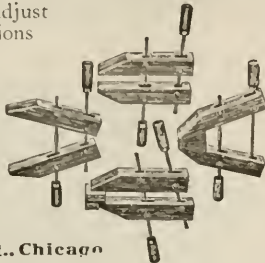

FIELD NOTES—(Continued)

which has heretofore been in charge of the Public School Lunch Guild, has now been made a part of the public schools.

EXHIBIT OF VOCATIONAL WORK AT PATERSON

An exhibit of the work of the boys, and of the boys at work at the Vocational School, Paterson, New Jersey, was given in the afternoon of July 14.

This school offers training in machine shop practice, patternmaking, drafting, and silk manufacture and design. The work of these different departments, covering as they do Paterson's principal industries, is so given that the boys who complete a course and graduate from the school will be able to look forward to employment offering advancement and a profitable future.

IN MEXIA, TEXAS

A system of general shop work along prevocational lines has been developed for this year in the schools of Mexia, Texas. The following types of work are offered: drawing, house wiring, painting, cement work, and wood work. More complete courses in manual arts will be offered next year. These will be based on the natural aptitudes of the students as manifested thru the variety of courses offered this year.

MITER SAW BENCHES

The "Tannewitz" Universal Double Revolving Arbor Saw Bench with Sliding Table and Taper Pin Gauges is the only logical tool for the wood shop where frequent setting up is the rule and accuracy is the goal. Send for bulletin.

THE TANNEWITZ WORKS
GRAND RAPIDS, MICH

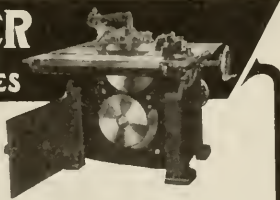

The Real Thing In Woodworking Machinery Parks Four-in-one

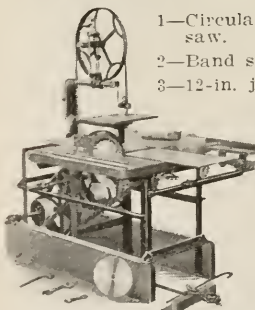

- 1—Circular rip and cross-cut saw.
- 2—Band saw.
- 3—12-in. jointer.
- 4—Bores with adjustable sliding table and regulating stop.

**Start your students
right—
Get a Parks!**

Send for complete illustrated catalog

The Parks Ball Bearing Machine Co.
CINCINNATI, OHIO

Chicago Office and Show Room, 617 Machinery Hall
Canadian Factory 200-210 Notre Dame E., Montreal
Western Office and Warehouse, 1113 Farnam St., Omaha

PARKS

Uncle Sam Supersteel Planes

A New Addition to our Extensive
Line of Carpenter's Tools

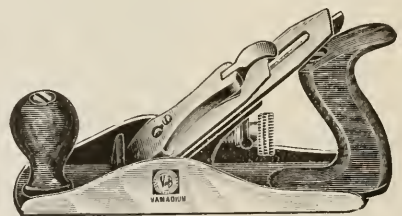

This Plane has our Supersteel Blade, made in one piece.

It can be sharpened back to the slot and will hold its edge.

Write for catalogue of Hammers, Braces, Screw Drivers, Planes and small tools.

**Vaughan & Bushnell
Manufacturing Co.**

2114 Carroll Ave.

CHICAGO

IT PAYS TO BUY A GOOD TOOL

Cushions, Spring Seats Upholstering Supplies

We issue price list which also contains valuable information for Instructors in Manual Arts.

It is free—write for it.

DODGE-DICKINSON CO.
Bloomington, Illinois

SHEET METAL WORKING TOOLS

For Manual Training Courses

WE have had many years of experience in fitting out Manual Training Schools with the necessary machines and tools for Sheet Metal Working Courses. If your school has or contemplates such courses, avail yourself of our experience and facilities.

Niagara Machine and Tool Works
Buffalo, N. Y., U. S. A.

NIAGARA

8th YEAR

SHOP APRONS

SAVE MANY
TIMES THEIR
COST

An
Adjustable
Neck Strap
Gives Each
Student
a Perfect
Fit



The Apron You Can Buy With Confidence

Standard in the Best Schools Everywhere

**INSTRUCTOR'S APRON FREE
WITH FIRST ORDER FOR 12 OR MORE**

Price White.....each 50c
Price Brown.....each 60c

DELIVERY SAME DAY

Send No Money—Just Your Order to
School Dept.

Canvas Products Corporation

Fond Du Lac, Wisconsin

SIMPLIFY GRINDING

With Mummert-Dixon Oilstone Grinders. Five wheels for almost every class of grinding. They accomplish the work quickly and accurately. With this machine your students can experience the pleasure of sharp tools.

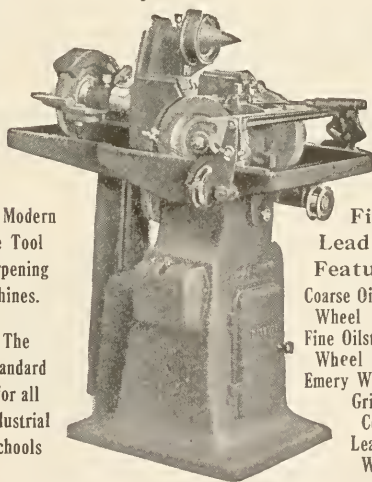

The Modern
Edge Tool
Sharpening
Machines.

The
Standard
for all
Industrial
Schools

Five
Leading
Features
Coarse Oilstone
Wheel
Fine Oilstone
Wheel
Emery Wheel
Grinder
Cone
Leather
Wheel

Furnished for motor drive or with counter-shaft
Send for full descriptive bulletin
MUMMERT-DIXON CO., Hanover, Pa.



MINUSA

(Trade Mark)

DRAWING INSTRUMENTS

MADE IN U. S. A.

Modern American methods of quantity production have enabled us to place on the market this line of drawing instruments (which possess a high degree of excellence) at a price within the reach of the Manual Training Student.

PERFECT SATISFACTION AT MODERATE COST

Price list sent on application.

KEUFFEL & ESSER CO., HOBOKEN, N. J.

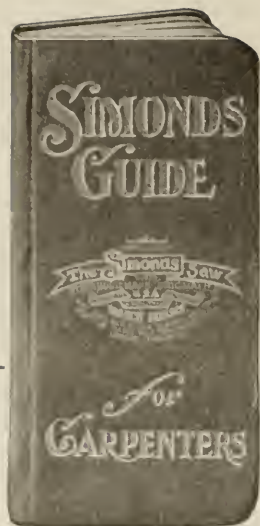

This Book Free To Instructors

It is vest pocket size, but contains practical information that a carpenter or wood-working instructor needs.

Included among the many bits of desirable information are rules for cutting rafters, making stairs and other designs. It also tells how to file and care for a hand saw.

Write for your copy today.

**Simonds
Manufacturing Co.**

"The Saw Makers"

FITCHBURG, MASS.

5 Factories

12 Branches

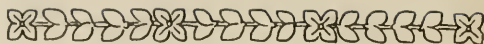

TRADE NOTES

A HANDY CATALOG

IF YOU have difficulty in securing the "hundred and one" things needed to complete the variety of articles being made by your students get a "Hard-to-get Materials" catalog. It describes fully a line of goods for manual training shops which can hardly be duplicated in any city in the country. It is published by the Thurston Manual Training Supply Co., of Anoka, Minn. This progressive firm carries such articles as upholstery supplies, tacks, hardware, hinges, pulls, springs and cushions, leather and imitation leather, cedar chest trimmings, extension table slides, tea wagon wheels, lamp shades, chair cane, glue, finishing materials, porch swing chains, desk lid supports, mouldings, phonograph hardware, etc.

Their seventh annual catalog just published illustrates and describes each article, and will be found to solve many difficulties. Write for one and have it at hand when needed.

PRANG ART BOOKS

"Theory and Practice of Color," by Snow and Froehlich. The most authoritative work on "Color." Illustrated with hand-painted "Color Charts." Price \$4.00; by mail, \$4.25.

"Art Simplified," by Pedro J. Lemos and John T. Lemos. A book of practical instruction in Art for advertisers, commercial artists, teachers and students. 22 full-page plates. Price, \$4.00; by mail, \$4.25.

"Lettering," by Thomas Wood Stevens. The standard work on the subject of lettering for students, designers and artists. 110 full-page plates. Price, \$3.00; by mail, \$3.25.

"Pencil Sketching Portfolios, Nos. 1 and 2," by George W. Koch. Each containing 15 plates of beautiful pencil sketches reproduced by the offset process. Portfolio No. 1, \$1.00; Portfolio No. 2, \$1.00.

"A Short History of Art," by De Forrest and Caffin. The most comprehensive single volume on the subject. Price, \$4.00; by mail, \$4.25.

"First Lessons in Batik," by Gertrude C. Lewis. A practical handbook, giving full information for Batik dyeing and Tie-Dyeing. Beautifully illustrated. Price, \$1.50; by mail, \$1.60.

"Permodello Modeling," by Snow and Froehlich. Gives full directions for innumerable uses of "Permodello," the permanent Modeling Clay which sets like concrete without firing. Beautifully illustrated. Price, \$1.50; by mail, \$1.60.

"Spoonbill Pen Lettering Tablets." A Tablet of exercises and drills for use with the "Spoonbill Pen" that makes lettering as easy as writing. Per tablet, 75c. "Spoonbill Pens," 3 sizes, per dozen, \$1.20.

"Constructive Anatomy," by L. J. Bridgeman. By the head of the department at the Art Students' League. Price, \$7.50.

Send for Descriptive Circulars

THE PRANG COMPANY

1922 Calumet Ave., Chicago
30 Irving Place, New York

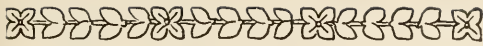

TRADE NOTES—(Continued)

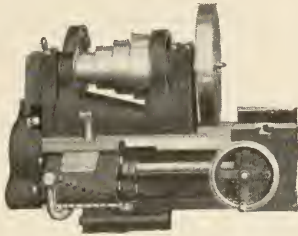

A QUICK-CHANGE GEAR BOX

The South Bend Lathe Works of South Bend, Indiana, has secured the shop right for the Flather Quick-Change Gear Box, invented by Herbert Flather of Nashua, New Hampshire, and used on the Flather Lathes. This is considered to be one of the most practical quick change gear boxes on the market. The quick-change gear box illustrated above allows 48 changes of feed or threads to be cut and of course gives the same number of changes to the cross feed screw.

This firm has been making a line of plain change gear lathes from 9" to 24" swing, inclusive. They are now practically doubling their line, and are equipping each size lathe with complete quick-change gear box which makes it a full quick-change gear lathe from 9" to 24" swing.

Before reaching a decision on equipment for your shop it would be well to send to the company and get their illustrated circulars describing their line.

Building Phonographs is Ideal Shopwork



It is easy, by our methods, and yet requires precision and delicacy of workmanship to achieve

best results. The boys will enter the work with new enthusiasm. At home the machine is a source of real, lasting pleasure. We supply blue prints, tone-arm, motors, case material and all accessories at lowest prices. Materials the very

best, fully guaranteed. Our machines play any make record. Write today for full particulars about our co-operative plan for manual training teachers. We plan the work for you.

Federal Supply Company
410 West 28th Street Indianapolis, Ind.

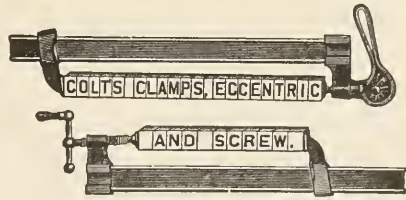

Forty styles of Quick Acting Clamps for the Worker in Wood, Cement and in the trades generally.

Your dealer will supply you.
Ask for catalog No. 296.

BATAVIA CLAMP CO.

237 Center Street BATAVIA, N. Y.

Marqueterie, Inlay Borders and Purflings for

Manufacturers and Vocational Schools

Insets for Trays, Panels, Cabinets, etc. carried in stock.
Natural and Transformed Veneers in great variety.
Lines in Holly, Satinwood, Box, Mahogany and Black

J. BERNARD & CO.

422 to 30 East 53rd St. New York

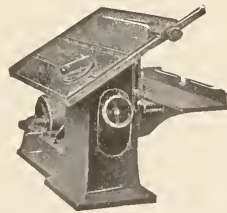

Crescent Wood Working Machines

are the tools your students will eventually use so give them the opportunity now of learning about this splendid line of wood working machinery.

Send today for our catalog of band saws, jointers, saw table, shapers, variety wood workers, planers, planers and matchers, cut off saws, disk grinders, borers, hollow chisel mortisers, Universal wood workers.

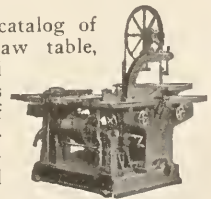

The Crescent Machine Co.

46 CHERRY ST. LEETONIA, OHIO



CLASSIFIED ADVERTISEMENTS



Do you want to sell or want to buy some school shop supplies? Do you want to employ a teacher? Do you want a new position? Advertise your wants in these classified columns. Rate 20c a line, minimum \$1.00.

ELECTRICAL PROJECTS

BUILD "PEPCO" ELECTRIC TOASTERS—A useful and attractive project. Buy the parts from the Practical Electrical Projects Co., Highland Park, Illinois.

UPHOLSTERY MATERIALS

UPHOLSTERY SUPPLIES FOR MANUAL TRAINING—We carry most things needed in the manual training departments such as, tools, imitation and genuine leathers, and upholstering supplies. Tray handles, catches and knobs, casters, mirrors, etc. Write for our Catalog. F. A. Rauch & Co., 410 So. Market St., Chicago, Ill.

CUSHIONS—You know your cushions will be made right when furnished by the Grand Rapids Cushion Company. Write for estimates on cushions and all kinds of upholstery supplies. Grand Rapids Cushion Company, Grand Rapids, Michigan.

CUSHIONS, APRONS, UPHOLSTERING SUPPLIES. If you make your own cushions we can supply the materials at reasonable prices. If you want complete cushions, we know how to make them, and our prices will interest you. Kunkle-Karl Co., 126 N. Washington St., Peoria, Ill.

MANUAL TRAINING LUMBER

FRANK PAXTON LUMBER CO., KANSAS CITY, KANSAS—We have for immediate shipment in any quantity: Plain and Quartered Oak, Red and Sap Gum, Walnut, Curley Redwood, Tennessee Red Cedar, Ash, Mahogany, Jenizero, Spanish Cedar, Redwood, White Pine, Poplar, Cypress, Maple, Sycamore, Holly, Beech and Magnolia. Write for price list and particulars.

AMERICAN WALNUT LUMBER—We carry a stock of over two million feet of Walnut Lumber, consisting of all grades and thicknesses from ½" to 4". Due to this large stock we are always in position to supply dry lumber for Manual Training use. Send us your inquiries. Frank Purcell Walnut Lumber Company, 12th Street & Belt Line, Kansas City, Kansas.

AROMATIC TENN. RED CEDAR BOARDS. Small shipments a specialty. Write us for prices delivered at your railroad station. Earthman Lumber Co., Murfreesboro, Tenn.

MORGAN MANUAL TRAINING MATERIALS—A perfect system of dry kiln enables us to give you lumber thoroughly dry. Carrying in stock large quantities of different woods permits us to fill your orders with the best selections. Write, sending us a list of the materials you desire. We will quote you attractive prices. Morgan Company, Oshkosh, Wisconsin.

LUMBER—Maisey & Dion, 2349 to 2423 South Loomis St., Chicago, Illinois, carry in stock a large and diversified stock of **MANUAL TRAINING LUMBER.** Fifteen years' experience with schools enables us to fill such orders satisfactorily.

BLACK WALNUT DIMENSION STOCK for manual training use ½" to 4" thick. At our low prices you can afford to use more of it. We have some specially fine cherry also oak and poplar, small orders a specialty. Wayne Cabinet Shop, 1008 Wayne St., Sandusky, Ohio.

POTTERY SUPPLIES

POTTERY SUPPLIES—Kilns, Clay, Modelling, Wheels, Tools. Plaster Models, Moulds, Stilts, Pyrometric Cones, Modelling Plaster, Metallic Oxides, Chemicals. Lewis Institute, Chicago.

BLUE PRINTS

FREE CATALOG AND SAMPLE—Blue Prints of Agricultural, Furniture Making, Mechanical Drawing, Wood Turning, Forge Work, Pattern Making and Whittling Problems. Make your work more practical. Work from blue prints. Schenke Blue Print Co., 1034 Carney Blvd., Marinette, Wis.

GRANDFATHER'S CLOCK—Blue prints, finishing material and instructions. Also works, dial, weights and pendulum can be purchased from us at surprisingly low prices. Send for particulars of our attractive offer. Clock Company, 1666 Ruffner St., Philadelphia, Pa.

BASKETRY

BASKETRY MATERIALS. Reeds, raffia, wooden bases, chair cane, Indian ash, splints, cane webbing, wooden beads, braided straw, rush, willow, pine needles, stenciling materials, books, tools, dyes. Catalogue and Directions, 15 cents. Louis Stoughton Drake, Inc., 34 Everett St., Allston, Station 34, Boston, Mass.

REED FOUNDATIONS AND SUPPLIES. Veneered tray bottoms, clear pine bottoms, lamp standards and fixtures, galvanized iron containers, finishing materials, etc. Send for catalogue. The Kessel and Nyhus Co., 1733 Stanford Ave., St. Paul, Minn.

PINE NEEDLES FOR BASKETRY—Brown and green, tied bunches, 30 cents lb. cash, without postage; 35 cents lb. if not prepaid. Tiny cones, 15 cents dozen. Florence Williamson, Laurel, Mississippi.

HICKORY SPLINTS

HICKORY SPLINTS—HAND MADE, ½" wide material for chair and basket weaving. One dozen seats \$1.50, postpaid. Splints ¾" wide, one dozen seats \$2.40. \$.25 extra beyond 5th cent. Cash with order. Prompt shipment. Rush your order. Hardin Splint Mfg. Co., Hawesville, Ky.

PRINTING SUPPLIES

TYPE—Manufacturers of Metal Type, Wood Type, Reglet, Brass Rule and Printers' Supplies. In no trust or combination. Empire Type Foundry, Buffalo, N. Y., Delavan, N. Y.

PRINTERS' TYPE—The character of your printed product depends largely upon the quality of the type you use. Our material is manufactured to the highest standards, accurate, and will withstand long wear. Have you our catalog? Rettew Printing Co., Foundry Dept., Reading, Pa.

SCHOOL SHOP SUPPLIES

SODERING SUPPLIES, including the famous Allen Non-Acid Sodering Fluxes—in stick, paste, salts and liquid form; handy soder sets, sodering tools, aluminum soder and flux. As pioneers in the development of fluxes that far surpass muriatic acid, in every way, and as the original exponents of non-acid fluxes, the House of Allen has for 25 years maintained a position of leadership in the Arts and Crafts concerned with sodering. Send for our Bulletins, L. B. Allen Co. Inc., 4584 N. Lincoln St., Chicago, Ill.

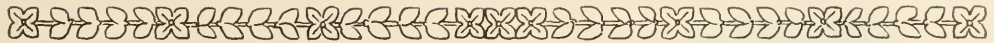

BOOK NOTES

THE changes that have come in manual training courses during the past thirty years are well illustrated in the development that has taken place in wood-turning. Compare, for example, the first course published in this country, the course at the old St. Louis Manual Training School, with the new course soon to be published in *Art and Education in Wood-Turning* by Klenke. The St. Louis course, published in 1887 was, perhaps, the result of as keen an analysis of the cuts used in turning and the drill necessary in gaining skill to produce them as is behind the present course. In fact, the analysis of 1887 in most of its essentials is still the analysis upon which all the best modern courses are based. But beyond this analysis the two courses have very little in common. The old course dealt with forms that were mechanical in contour—only an occasional free curve being employed; the new course uses many free curves and constantly appeals to the student's sense of beauty of curvature and proportion. The old course was made up of exercise pieces only; the new course makes use of a few such exercise pieces, but for the most part, it consists of objects that have some use and therefore some special interest to the student who makes them. The old course gave no thought to individual differences in the skill, taste and capacity of the pupils; the new course provides in a most practical way to meet the needs of all students.

Mr. Klenke says that when he began teaching in the Central High School at Newark, N. J., he noticed a growing tendency to drop wood-turning. He tried to find the reason for the lack of interest in this subject, which to him was most interesting. He reached the conclusion that the cause was largely in the fact that the objects presented as problems were lacking in their appeal to the students, and especially in their appeal thru artistic qualities. They were lacking also in the available data on the problems presented. Hoping to remedy these faults and fill what seemed to him to be a very apparent need, he set out to write a book on the subject. The result is *Art and Education in Wood-Turning*. In addition to these there was one more motive that should not be lost sight of. He hoped thru the book to help revive wood-turning as an artistic handicraft.

Mr. Klenke's training and experience were such that it was most natural that he should be interested in the artistic side of his course in wood-turning. After graduating from the De Witt Clinton High School and the carpentry and building course of the New York Trade School, he studied at the

Art Students' League, where he received "honorable mention." He is a graduate of Pratt Institute, where he won a competitive scholarship in art, altho specializing in woodworking at the time. He has studied wood-carving, gilding, metalwork, modeling, designing and is a registered architect in New Jersey. It is, therefore, not surprising that Mr. Klenke has emphasized the art as well as the educational possibilities of wood-turning in his book.

MANUAL arts teachers everywhere are called upon to plan and equip school shops, yet very few of them have had the definite training or experience to do such work. The best they can do is to look up catalogs, consult millwrights and salesmen, read engineer's handbooks, and then, take the risk. It is not surprising, therefore, that costly mistakes are sometimes made which need not have been made if the teachers had been reasonably well informed on some of the fundamentals of the engineering and economic problems involved in the selection and installation of shop equipment.

It seems surprising that up to the present time no book has appeared which gives the teacher the information he needs on this subject, yet such is the case. While it is true that a book cannot take the place of an engineering course of training and years of practical experience it is also true that even engineers, as well as normal graduates, need the help of a book dealing with this special subject of school shop installation and equipment. Such a book has recently been written by Prof. Leon S. Greene of the University of Florida, formerly of the University of Wisconsin, and will be published by The Manual Arts Press very soon.

TEACHERS of electricity, auto-mechanics, or general shop work, in junior or senior high schools will be interested in the following points about the book *Practical Electricity for Beginners*, by George A. Willoughby:

1. It simplifies explanations of principles which in the past, have been too academically treated for the boy of this age.
2. It will save the teacher a great deal of the time he now uses in making outlines and preparing subject-matter.
3. It will save the student much time because he can turn to this one source for study and review.
4. It will stimulate the boy to do electrical jobs at home and give him the information from which to work.
5. It will soon be available to the public thru The Manual Arts Press.

A New Wiley Text



Wright's Automotive Repair

AN INSTRUCTION MANUAL OF REPAIR JOBS FOR THE GENERAL REPAIRMAN AND OWNER

By J. C. Wright, B. S. and M. A., Chief, Industrial Education, Service Federal Board for Vocational Education, formerly Educational Director Rahe Auto and Tractor School, Kansas City, Mo.

IS NEW—PRACTICAL—FLEXIBLE

In this new book Mr. Wright has presented the general automotive repairman's work in a sensible and logical way. He includes the actual practice covering every job common to general garage work and then gives the "whys" in Part II. Thus it makes an ideal combination of practice and theory.

WRIGHT'S "AUTOMOTIVE REPAIR" contains 544 pages 6 by 9. It is fully illustrated, and the binding is of durable cloth. The price is \$3.50 postpaid.

Have a copy sent on FREE EXAMINATION.

Published by
John Wiley & Sons
Incorporated
432 Fourth Ave.
New York City

FREE EXAMINATION COUPON

John Wiley & Sons, Inc., 432 Fourth Avenue, New York City. You may send me the following on 10 days' approval:

WRIGHT'S AUTOMOTIVE REPAIR

I agree to pay for the books or return them within 10 days of receipt.

Name

Address

If teacher, state school.....

If not teacher, give reference.....

M.T.M. 10-21

The best is none to good for the boys—

Specify GREENLEE VISES

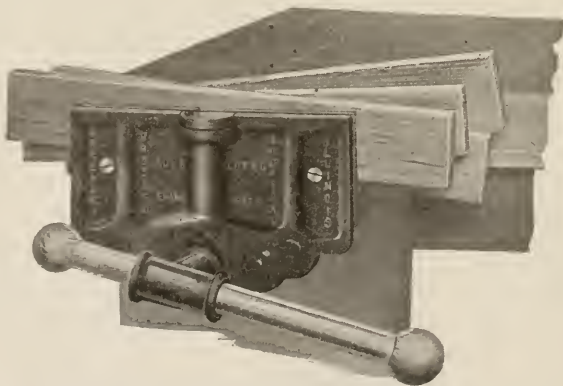

A Greenlee Cushion Grip Vise in action

BECAUSE

they have

Continuous screw action in both directions.

Free turning of the screw in either direction.

Quick action available at any handle position.

A screw not mutilated by long grooves.

A complete nut fully engaging the screw.

Simple, strong and positively connected parts.

Ask for descriptive booklet

GREENLEE BROS. & CO.

Rockford, Illinois

MANUAL TRAINING MAGAZINE

EDITORS CHARLES A. BENNETT, Peoria, Illinois.

WILLIAM T. BAWDEN, Assistant to Commissioner of Education, Washington, D. C.

ASSOCIATE ARTHUR D. DEAN, Professor of Vocational Education, Teachers College, New York City

EDITORS FRANK M. LEAVITT, Associate Superintendent Public Schools, Pittsburgh, Pa.

WILLIAM E. ROBERTS, Supervisor of Manual Training, Public Schools, Cleveland, Ohio.

Business Manager L. L. SIMPSON.

Published monthly by The Manual Arts Press, 237 N. Monroe St. Peoria, Illinois.

Subscription Price, \$1.50; Canada, \$1.80; Foreign, \$2.00. Single Copies, 25 cents; Foreign, 50 cents.

Subscriptions, remittances, and manuscripts should be sent to THE MANUAL ARTS PRESS, Peoria, Illinois.

Special Toy-Making Number

CONTENTS

THE PROJECT PROBLEM (Illustrated).....	<i>Allen D. Backus</i>	143
PUTTING "PEP" INTO TOYS (Illustrated).....	<i>Harry E. Wood</i>	151
TEACHER TRAINING IN NEW YORK CITY (Illustrated).....	<i>Florence N. Levy</i>	155
AN AUTOMOBILE SHOW (With photograph).....	<i>Lester C. Smith</i>	160
EDITORIAL REVIEW FOR THE MONTH.....		161
Toy Designing—The Woman's Institute of Domestic Arts and Sciences—New Course Started at West Virginia University—George W. Eggers goes to Denver.		
A POINT OF VIEW.....	<i>Arthur D. Dean</i>	165
WASHINGTON CORRESPONDENCE.....	<i>William T. Bawden</i>	168
Education in the Reorganization of the Executive Department—A Department of Public Welfare, Education and Labor Suggested—The Department of Education Program.		
IN FOREIGN COUNTRIES.....		170
Manual Training and the Near East Relief.		
PROJECTS, PROBLEMS AND NOTES.....		172
Toys and Boys—Soldier—Machine Gun—Toys made for sale at Rochester—Toy Motor Truck—Toy making in Pittsburgh; Doll Cradle, Toy Auto, Wheel Horse, Toy Airplane, Rocking Duck—Windmill—The Walking Wallapus.		
CURRENT PUBLICATIONS.....		184
FIELD NOTES.....		IV
From New Jersey—New England Items—Around New York—From the Southwest—From the North—The Milwaukee Meeting—Wisconsin Protects Laboring Children—The Vocational Summary Discontinued—A General Industrial School—New School Building at Cortland, New York—Items of Progress.		
TRADE NOTES.....		XXX
BOOK NOTES.....		XXXIX

This Magazine is kept for sale at McClurg's in Chicago, and Brentano's in New York.

Entered at the Post Office at Peoria as Second-Class Matter. Copyright, 1920, The Manual Arts Press.

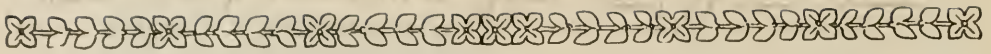

FIELD NOTES

FROM NEW JERSEY

THE Boys' Vocational School of Newark, New Jersey of which Harold J. Fuller is principal has started the school year with an enrollment of 250 and a waiting list of at least as many. It will be nearly another year before Newark's New Vocational School is completed. This building will probably be the largest and most completely equipped vocational school in the country which is a part of a public school system. The cost of the building exclusive of equipment will be \$1,070,000.

A new era in the relationship between the trades and Newark's vocational schools is apparently at hand. This is indicated by the request of the local Electrical Union that courses of study be given in day school classes for apprentices. On account of lack of space this is not possible at the present time but evening school courses have been arranged for along lines worked out by the union with added work as required by the state department. These courses will primarily be suitable for apprentices classified in classes C and D. Later on courses will be added to fit the needs of classes A and B. These courses in a general way will cover the following fields;

- A) Trade Judgment
- B) Trade Science
- C) Trade Mathematics
- D) Trade Drafting

Mr. Fuller is making every attempt to extend such co-operation to other trade unions.

It may be of interest to those concerned with vocational school organization and administration to read of the application of the intensive plan which Mr. Fuller has made for his school. Mr. Fuller writes as follows:

INTENSIVE WORK IN THE BOYS' VOCATIONAL SCHOOL, NEWARK

"The success evidenced by the introduction of the intensive plan of instruction into the manual arts department of the Newark school system warranted the adoption of a similar plan by the Boys' Vocational School. It has been modified in form, to make compatible with our problems and aims.

"The trade technical and non-vocational courses are departmentalized. Under the former scheme of organization the English and drafting departments best lent themselves to this plan of intensive work. Heretofore the classes in English alternated

with classes in drafting. As a consequence of part sessions, holidays, etc. the continuity of instruction was frequently disrupted. The periods of training were disconnected and valuable time was lost in necessary review.

"The cycle of intensive work covers six consecutive weeks, during which interim one-half of the school is receiving instruction in English, while the remaining number is engaged in drafting. At the conclusion of the interval the two groups interchange. The plan has been in operation for approximately six months. Certain small modifications have been introduced made expedient by visible weaknesses. A conference is held at the completion of each cycle, at which time conclusions are drawn and future plans of procedure are formulated.

"Quantity production is the outstanding feature of this scheme. A 100% increase in production of drawings satisfactorily completed from the standpoint of technique has resulted without accompanying loss of thoroughness of understanding. A greater interest in subject matter is awakened by this plan. Under former conditions the lapse of time between periods of instruction seriously interfered with interest in the subject matter. Information presented was forgotten before there was opportunity of using the data. It was difficult to clinch the subject matter in lectures and class discussion. Work is now resumed from the previous day's point of departure and with additional information is carried on to completion. The power of visualization and constructive imagination is not allowed to deteriorate to such an appreciable extent. The customary 'warming up' process is no longer necessary. Obviously, checking levels may be more closely scrutinized. The daily contact produces a likeness to trade conditions and allows of greater accumulation and absorption of trade information. The importance of drafting as a universal shop language is being more successfully stressed.

"In English there has been manifested an increased power of expression that results from intimate and continuous contact with the subject. An incompleting project may be finished the following day. It has been possible to make a decided change in the content of the daily lessons. It is our endeavor to teach the boys to teach themselves. This self-teaching—an ideal—is not easy, for habit formation requires constant practice with no interruptions. The boys are taught to use the dictionary intelligently. A ten minute drill is given every morning. The reading habit is being developed. A Literary Digest Club has been formed and one

Get this Valuable Instruction Book ON WOOD FINISHING

It's the best book ever published on Artistic Wood Finishing and should be in the hands of every Wood Finishing Instructor. It is full of valuable information on finishing all wood—soft and hard. Considerable space is devoted exclusively to the finishing of manual training models. It's the work of experts—illustrated in color.

How To Get It FREE

Write us (mentioning the name of the firm from whom you buy paints, varnishes, etc.) and we will gladly send you our book "The Proper Treatment for Floors, Woodwork and Furniture" free and postpaid.

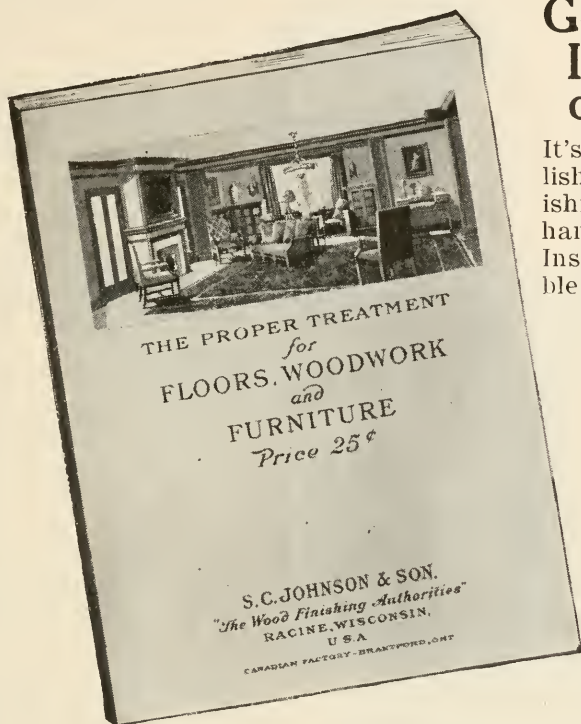

JOHNSON'S ARTISTIC WOOD FINISHES

Johnson's Artistic Wood Finishes are particularly adapted for manual training work as they may be applied by the youngest and most inexperienced pupils with good results. Johnson's Artistic Wood Finishes are standard for manual training—they are being used all over the United States and Canada for this purpose.

The perfection of Johnson's Artistic Wood Finishes has been the work of years. You get the benefit of our experience—of our money expenditure—of our knowledge of woods. Our plant is equipped with up-to-date mills and machinery and every department is in the hands of experts.

Our line of Artistic Wood Finishes is complete—it includes:

Johnson's Prepared Wax

Johnson's Wood Dye

Johnson's Crack Filler

Johnson's Paste Wood Filler

Johnson's Perfectone Undercoat

Johnson's Perfectone Enamel

Johnson's Electric Solvo

Johnson's Varnishes

You will find this entire line described in our book. Any time specific information is desired, or whenever you want specially finished wood panels, do not hesitate to write us. We solicit correspondence with Manual Training Instructors.

S. C. JOHNSON & SON, Dept. MT11, Racine, Wis.

"The Wood Finishing Authorities"



FIELD NOTES —(Continued)

period per week is set aside for reading and discussion of some topic in the "Digest." Now reading is being prosecuted both for pleasure and profit. These developments, in conjunction with the regular work, have convinced us that the new schedule has justified its introduction.

"In conclusion, the intensive plan has filled a much needed gap and it is our aspiration to amplify it and introduce it into other departmental groups."

—ALLEN D. BACKUS.

NEW ENGLAND ITEMS

THE Sloyd Training School, of Boston, with its enviable record of accomplishment for more than thirty years, has ceased to exist as a private institution, having been adopted, so to speak, by the Boston School Committee for this year at least. Josef Sandberg, of Winchester, Mass., who became the active head of the Sloyd Training School on the death of its founder, Gustaf Larsson, has been appointed assistant director of the Department of Manual Arts, Boston School Committee, and has been assigned to the continuance of the work of this school.

There is a very promising class of students at the school this year, and the curriculum has been broadened and strengthened considerably and the outlook for the year is very encouraging.

This school supplies many of the members of the permanent teaching force and from this source also are drawn many of the temporary or substitute teachers required from time to time in the Boston Schools.

In a future issue there may appear some further data concerning the work and history of this interesting training school for teachers, the pioneer of its kind in this section of the country.

PREVOCATIONAL CENTERS

The prevocational centers of Boston graduated two hundred thirty-seven boys last year, and it is interesting to note their expressed intentions as to the future. Of the 237 boys: Seven elected to attend English High School; sixty elected to attend Boston Trade School; eight elected to attend Brighton High School; twelve elected to attend Charlestown High School; twelve elected to attend Dorchester High School; nine elected to attend East Boston High School; twenty-seven elected to attend High School of Commerce; four elected to attend Hyde Park High School; twenty-eight elected to attend Mechanic Arts High School; one elected to attend Public Latin School; two elected to attend

South Boston High School; three elected to attend West Roxbury High School; three elected to attend Wentworth Institute; two elected to attend other schools; two made no choice; fifty-seven went to work.

The above statistics would seem to indicate that the prevocational type of educational work is creating a healthy interest among the boys for better and more complete education.

CHANGES IN POSITIONS

ARTHUR HAMILTON has returned to Boston after an extensive experience with the Bethlehem Steel Corporation in their instructional department. He has been assigned to grade work, with which he was associated before entering the employ of the Bethlehem Corporation.

JOHN Y. MURRAY, electrical instructor in the Cutter Prevocational Electrical Shop, Boston, has associated himself with the Continuation Schools in Cambridge, Mass., where he will teach electrical work.

EARL FREEMAN, of Everett, Mass., who has been employed for several months in the New Bedford, Mass., Trade School, has been appointed electrical instructor in Boston.

MISS FLORENCE O. BEAN, First Assistant, Dept. of Manual Arts, Boston, is enjoying a sabbatical leave this year, and is completing work necessary for a degree at Boston University.

MISS BESSIE D. JAMES, for several years a teacher of elementary manual training in Boston Schools, has accepted a position as teacher of English in the high school at Norwood, Mass.

MISS ANNA M. POND, teacher of elementary manual training in Boston Schools for many years, has retired from the service.

BOSTON VOCATIONAL SOCIETY MEETS

The Vocational Education Society of Boston will hold its first Fall meeting at Healy's Hotel, Boston, on Saturday, October 8, 1921.

At that time former president George C. Greener, Director of the North Bennet Street Industrial School, Boston, will favor the members and guests with an account of his travels while visiting various foreign countries this summer. The officers of the Society for the coming year will be installed as follows: President, George F. Hatch; Vice-Pres., Andrew J. Leahy; Secretary, Maurice J. Moriarty; Treasurer, Richard Benson; Librarian, Martin L. Olson.

—FRANCIS L. BAIN.

Back of every Sturtevant equipment is an organization which for sixty years has maintained a position of leadership in the design construction and application of fans, fan systems, and related problems.

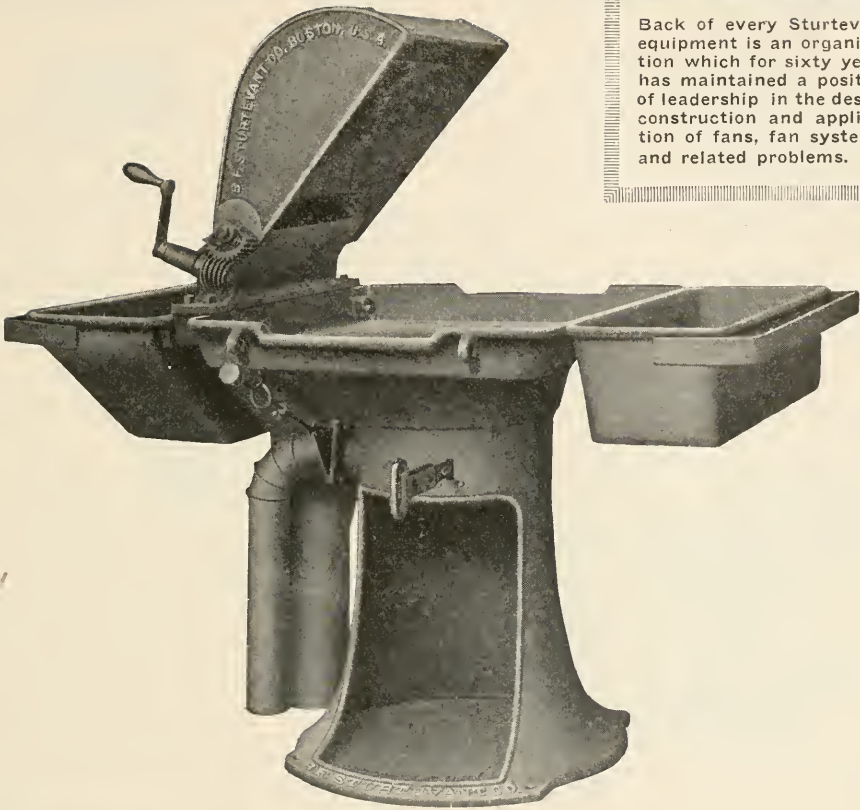

Sturtevant

PUTS AIR TO WORK

Students, like workmen, develop interest and receive a keen satisfaction when using dependable tools and equipment. Sturtevant Forges are not only dependable but are easy to work with, convenient and trouble proof. They are designed with a full knowledge of the duty they are expected to perform and with the wisdom gained from long experience of the best way to perform it.

The high quality of Sturtevant Forges is reflected in the ease with which the desired skill is acquired by the student.

Sturtevant equipment is standard not only in schools but in the shops of the country as well. Consultation invited.

B. F. Sturtevant Company
Hyde Park, Boston, Massachusetts And All Principal Cities



FIELD NOTES—(Continued)

AROUND NEW YORK

REGISTRATION of students at the New York Evening School of Industrial Arts, 204 East Forty-second Street, for the season of 1921-22, in industrial art subjects—book illustration, costume design, interior decoration, jewelry design, poster design, textile design, plastic design, mural decoration, and drawing from the figure and from cast, was held during the week of September 12 to September 16.

Applicants were requested to bring samples of work done. Courses will be open to art students who wish to enter some particular field of industrial art and to art workers who wish to perfect their technique.

Courses will run throughout the school year of 120 evenings and certificates will be issued to those whose work has been approved by their instructors. Short courses in batik will be given in the principles of design class.

The courses are free to men and women over sixteen years of age who are found qualified. Materials also are furnished free to all students.

Applicants must present themselves in person. No application blanks will be sent by mail. Instruction will be given by men and women who rank high among the art workers of the city, and who are acknowledged as leaders in their special departments.

VOCATIONAL TEACHER TRAINING

In co-operation with the Board of Education of the City of New York, the State Department of Education is maintaining a permanent evening vocational and commercial teacher-training program in the city. One of the problems of the State Department each year is to secure the right type of students for the training classes, and this announcement is intended to attract the attention of the trade and technical people and the commercial people to the courses offered.

The evening vocational teacher-training centers are in Brooklyn and Manhattan. The courses in these centers are open to qualified trade and technically trained men between the ages of twenty-three and thirty-eight with at least five years' experience of journeyman grade. The men selected for the new classes will represent the following trade and technical fields: bricklaying, painting and decorating, electrical construction, printing, including composition and presswork, machine shop, carpentry, cabinet making, auto mechanics, sheet-metal work, architectural drafting, machine draft-

ing, industrial chemistry, shoemaking, tailoring, general textiles, jewelry making, and designing.

The courses are two years in length, sixty-two sessions in each year. The centers for the work will probably be the Murray Hill Evening Trade School and the Brooklyn Evening Trade School.

The work of the courses will include a study of history, theory, principles and problems of vocational education; applied psychology and education; analysis of trades and organization of courses of study; types of vocational education in New York; methods and mechanics of teaching industrial subjects; and practice teaching.

The satisfactory completion of the two years of work will secure for the student a special certificate issued by the commissioner of education entitling him to teach his trade or technical occupation in the public vocational schools of the state. The course is of very material assistance in securing a creditable rating on the special examination required of shop and technical teachers before an appointment to positions in New York City.

Extensions of the vocational education program in the public schools are constantly requiring additional trained teachers. The continuation school program will require new teachers. The evening trade and technical extension courses are only partially developed, and in the immediate future will need many new teachers. The training will also be of immediate value to anyone charged with supervisory responsibilities in a commercial establishment or plant or preparing for such work.

The evening commercial teacher-training classes are conducted in Manhattan only. The origin of these classes has grown out of a demand for competent commercial teachers, who are not only trained in commercial subjects, but have had broad practical experience. Such teachers at present are especially needed in the continuation and evening schools, where employed groups are largely enrolled.

In order to draw properly qualified men and women from business occupations the state offers, without charge, a two-year evening commercial teacher-training course, leading to a diploma and license to teach business subjects which are related to specific occupational experiences. The course is two years in length, sixty nights a year, two hours a night.

The requirements for admission are graduation from an approved high school or the equivalent, and three years' satisfactory business experience in one of four groups of commercial occupations; (1)



“Oliver” No. 127 Variety Belt Sander

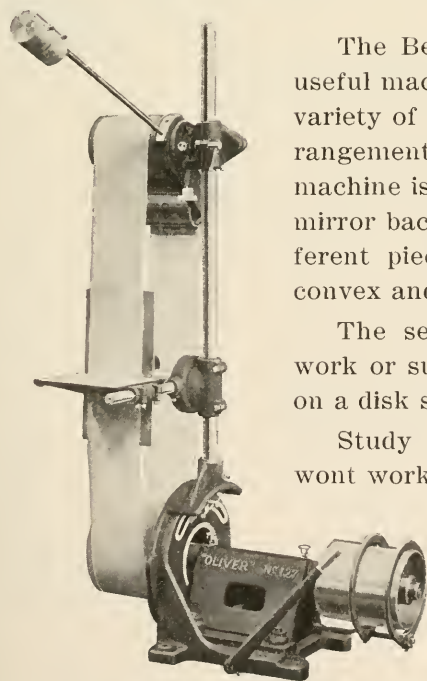
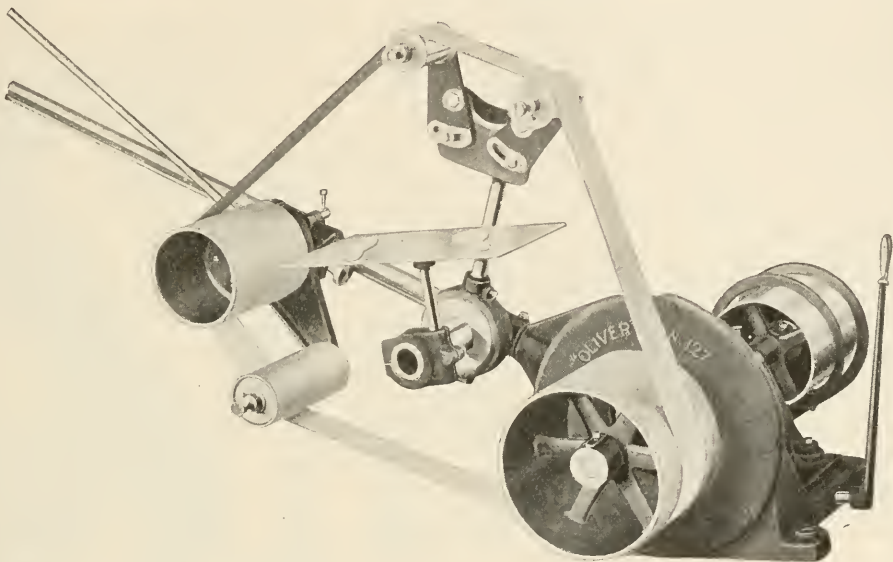

The Belt Sander here illustrated is a very useful machine. It adapts itself to a very wide variety of sanding and polishing jobs. The arrangement above illustrated shows how the machine is used for sanding brush-backs, hand mirror backs, oval picture frames, etc.; for different pieces other set-ups are used. Both convex and concave surfaces may be sanded.

The set-up shown below shows how flat work or such curved work as could be sanded on a disk sander is cared for.

Study your jobs and see if this machine wont work wonders for you.

Oliver Machinery Co.

Grand Rapids, Michigan, U.S.A.

Branch Offices and Salesmen in principal cities



FIELD NOTES—(Continued)

office, clerical positions—office manager, chief clerk, general clerk, receiving clerk, shipping clerk, stock clerk, file clerk, mailing clerk; (2) office recording positions—head bookkeeper, assistant bookkeeper, machine operator, calculating machine operator, entry clerk, ledger clerk, cost clerk, statement clerk; (3) secretarial, stenographic and office machine positions—secretary, stenographer, typist, billing clerk, duplicating machine operator, addressograph machine operator; (4) retailing and wholesaling positions as store manager, floor manager, sales manager, buyer, department head, salesperson, stock clerk, and cashier.

Men who apply for admission must be neither less than twenty-three nor more than thirty-eight years of age; women not less than twenty-one or more than thirty-five years of age.

The courses offered the first year include principles and problems of commercial education, principles of psychology and education, study and analysis of junior commercial occupations, organization of courses of study and observation of courses of study and observation of commercial classes.

—W. H. DOOLEY.

FROM THE SOUTHWEST

DURING the four years in which vocational education classes have been carried on under the Smith-Hughes law in Texas there has been a steady, healthy growth in this phase of the work. During the first year six schools in five cities carried on some industrial work. Most of the work at that time was intended to help the boys who were to enter the Army.

After the armistice was signed the real problem of vocational education was taken up and has grown steadily until the year 1920-21 has been one in which a good showing has been made.

The following summary shows how the work has grown in all lines:

Federal aid received by state in 1917-18, \$62,000.00.

Federal aid received by state in 1920-21, \$145,000.00.

Number of classes organized in agriculture, home economics, and trades, in 1917-18, 50.

Number of classes organized in 1920-21, 249.

Number of persons enrolled in 1917-18, 1,372.

Number of persons enrolled in 1920-21, 3,963.

From this it will be evident that during the four years there has been a steady growth in the work and more and more people are taking advantage of the opportunity offered.

During the year just ended fourteen cities carried on work in trades and industries. The work in these cities was divided as follows: day trade, seven; evening, eight; part-time, six. Some of the cities had all three types of classes.

The day trade school has not been promoted as much in Texas as in some states. We feel that aid should be given first to those who have left school and entered industry, therefore our part-time and evening school program has been given more attention than the day trade. This is receiving the hearty support of the industrial workers as well as the employers.

So far teachers for industrial classes have been trained by the Agricultural and Mechanical College and the University of Texas. Only teachers of shop subjects have received training so far in evening classes by itinerant teacher-trainers. Enough teachers have been trained to meet present needs. Prospects for the year 1921-22 are good as the last legislature made it possible to give state as well as federal aid.

—E. A. FUNKHAUSER.

FROM THE NORTH

THE four-weeks' vocational conference at Dunwoody Institute during August, under the auspices of Federal Board representatives, brought together one hundred leaders of industry and vocational educators from a great many states. The conference was a new departure, taking on the aspects of a school. The purpose was to reach a common understanding of the problems of the industrial leaders and the vocational educators.

During the conference Dr. Albert Bushnell Hart of Harvard University accorded to Minnesota first place in the development of vocational education. He based his observations on three institutions: (1) The Girls' Vocational High School, Minneapolis, for taking care of the needs of girls and young women. (2) The University Farm School at St. Anthony Park for meeting the needs of the great agricultural population of the state. In this school, Dr. Hart saw a pioneer in the practical combination of technical agricultural education with academic instruction. (3) The Dunwoody Institute, Minneapolis, distinguished Minnesota as a leader in vocational education for boys and young men of the towns and cities, according to Dr. Hart.

The Central Division of the Minnesota Education Association met at the State Teachers' College St. Cloud, October 13 and 14. All high school activities were grouped into one sectional meeting,

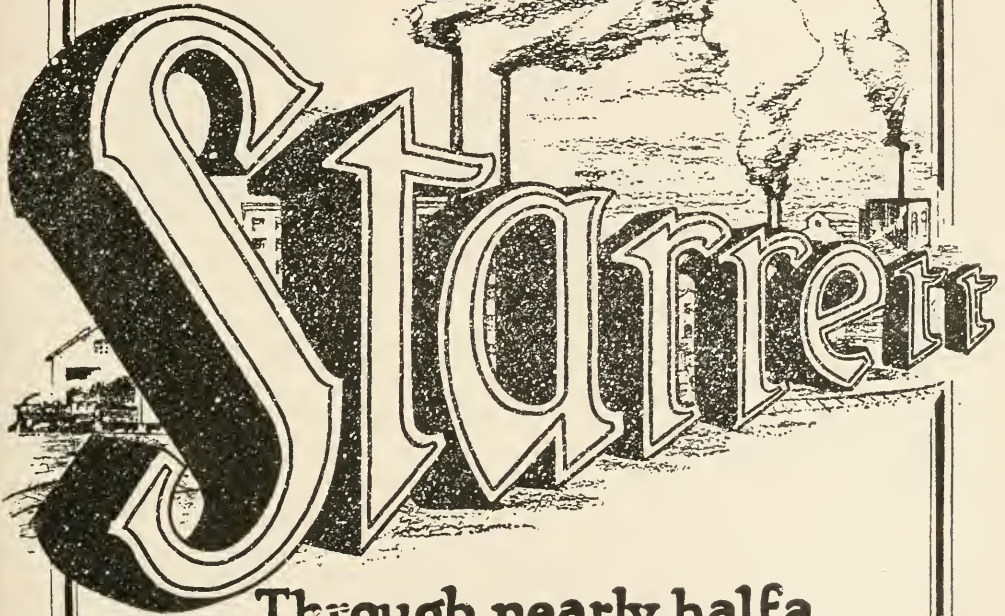

Through nearly half a century of service to the metal-working trades the name 'STARRETT' has stood for accuracy in precision tools

Catalog No. 22 "EF" describing and illustrating 2100 fine tools sent free on request- write for copy

THE L. S. STARRETT CO., ATHOL, MASS.

**THE WORLD'S GREATEST TOOLMAKERS
Manufacturers of Hack Saws Unexcelled**

42-238

and all activities of the upper, middle, lower, rural, and opportunity grades were grouped under these main divisions. Dr. W. C. Bagley of Teachers' College, Columbia University, Dr. Henry H. Goddard, Director Juvenile Research Department, Columbus, Ohio, and Dr. Charles H. Judd of Chicago University were the principal outside speakers. Other Division Meetings were held at Virginia, Oct. 6-7-8; Crookstone, Oct. 19-20-21; Moorhead, Oct. 13-14; Bemidji, Oct. 20-21-22; Mankato, Oct. 6-7.

The fifty-eighth convention of the Minnesota Educational Association will be held in Minneapolis, November 2 to 5. The principal speakers from outside the state will be: Anna E. Richardson of the Federal Board, E. K. Wickman, Institute for Juvenile Research, Chicago, and Clyde A. Bowman, Stout Institute for the program of the Industrial and Household Art Department; J. C. Wright, of the Federal Board and L. A. Wilson, president National Society for Vocational Education, for the Program on Vocational Education.

Mr. Bowman will also be one of the speakers on the program of the Manual Training Division in addition to a number of industrial school men within the state.

In the reorganization of the manual arts work at the Technical High School, St. Cloud, a general shop course of one year is provided for freshmen. This is required of all boys who have not had the junior high school shopwork. Three sections in this course are organized. Experiences are given in six shops during the year: woodwork, mechanical drawing, printing, electrical work, machine shop, and automobile gas-engine work. The applied art side is given special emphasis. Additional teachers who are assisting with the course are Robert Miller, formerly at Farmington, Minnesota, woodwork and gas engine; C. S. Chapman, formerly at Deer River, Minnesota, printing and electricity; and Robert Hilpert formerly an interior decorator, Chicago, applied art.

—JOHN FRIEZE.

THE MILWAUKEE MEETING

THE FIRST number for this year of the *Mid West Bulletin* issued by The Vocational Education Association of the Middle West has been sent out to the members of the association. This is the eighth year of the existence of this bulletin.

This particular issue lays stress on the annual meeting which will be held in Milwaukee January 11 to 14. It points out the fact that Milwaukee

has an auditorium not surpassed in its possibilities for taking care of a large convention by any other in the United States. The Milwaukee Auditorium will accommodate under one roof all the exhibit, all sectional meetings, and all the main assemblies. This, it is shown, will save much of the time of the delegates that would ordinarily be lost in moving about from one location to another.

A large number of the teachers of Milwaukee are already organized into a convention committee with Chas. F. Perry, supervisor of industrial education, 336, 25th Street, as chairman. This committee can be depended upon to do Milwaukee's share in making this a successful meeting; while, as the bulletin suggests, a large share of the responsibility for its success rests upon each member.

The committee on industrial education consists of W. F. Faulke, Supervisor of Trades and Industries, Madison, Wisconsin, chairman; L. P. Whitcomb, Director of Trades and Industries, Manitowoc, Wisconsin; J. V. Lynn, Professor of Vocational Education, Ames, Iowa; H. G. McComb, Supervisor of Trades and Industries, Indianapolis, Indiana.

The officers of the association for this year are:

President—J. A. James, Professor of Agricultural Education, University of Wisconsin.

First Vice President—Miss Cleo Murtland, Department of Industrial Education, University of Michigan.

Second Vice President—F. C. W. Parker, Secretary, International Kiwanis Clubs, Chicago, Illinois.

Secretary—Leonard W. Wahlstrom, United States Veterans' Bureau, Chicago, Illinois. (Office at 1711, Estes Avenue, Chicago).

Treasurer—James McKinney, Educational Director, American School of Correspondence, Chicago, Illinois.

WISCONSIN PROTECTS LABORING CHILDREN

THE new child labor law of Wisconsin provides for the necessity of securing working permits by children who wish to enter employment up to the close of their seventeenth year. This age limit is higher than in most states at the present time. The workmen's compensation law places a heavy responsibility on employers who accept children without permits, in that in case of accidents they are liable for three times the compensation otherwise provided for, a liability which can not be covered by insurance. These facts in addition to

LITTLE GIANT MANUAL TRAINING DEPARTMENT Special Equipment

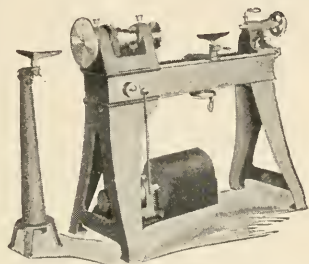

LITTLE GIANT WOOD LATHES

Individual Motor Driven, or Belt Driven from above or beneath.

Furnished with either Bench or Floor Legs. Wide choice of optional tools and equipment. Four speeds.

Many new, exclusive and practical features. All bearings are Hyatt High Duty Roller Bearings which greatly reduce power required. Ball Thrust bearings at all points of end thrust.

Sold on 30 days trial, and GUARANTEED FOREVER against defective material and workmanship.

LITTLE GIANT METAL LATHES

Individual Motor Driven, or Belt Driven from above or beneath.

Furnished with either Bench or Floor Legs. Wide choice of optional equipment. Three speeds.

Many new, exclusive and practical features are also found on our metal lathes. They are fitted to receive attachments for grinding, milling, gear cutting, etc., all of which we will furnish at a small fraction of the cost of a separate machine for such work.

Sold on 30 days trial and GUARANTEED FOREVER against defective material and workmanship.

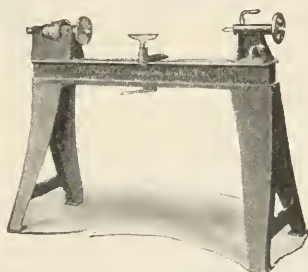

LITTLE GIANT POWER HAMMERS

Individual Motor Driven, or Belt Driven from above. Hundreds of different form-forging dies for instruction purposes.

Standard equipment with leading Technical and Manual Training Institutions.

Sold on 30 days trial, and GUARANTEED FOREVER against defective material and workmanship.



DO NOT OVERLOOK

Metal Working Equipment in your school. Wood can never be made anything else, while metal working and alloying are in their infancy.

The Industrial Leaders of the world, to a very large extent, began as metal workers.

Wood working is artistic, and trains mind, eye and hand to deftness. Metal working does all this, and more. It is also practical, and the graduate invariably finds a position waiting for him, while the wood working department graduate usually takes up something else and his instruction is forgotten.

Little Giant Equipment for Technical and Manual Training Schools consists of a full line of all metal and wood working machinery including accessories and tools for same.

On Motor Driven Equipment, information will be required as to Current, Voltage, Phase and Cycles of Motor.

Our business commenced in January, 1876, more than 45 years ago, and our Little Giant Products are used throughout the world. We are anxious to serve you for we can do it well.

Quotations and descriptive literature can be secured from any jobber, or direct from us.



LITTLE GIANT COMPANY

220 ROCK ST.

MANKATO, MINN., U. S. A.

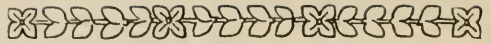

FIELD NOTES—(Continued)

the apprentice law which provides for a certain number of hours of formal instruction, together with the well-developed vocational school system thruout the state give Wisconsin a unique opportunity for leadership in vocational education.

THE VOCATIONAL SUMMARY
DISCONTINUED

NOTICE has been sent out by The Federal Board for Vocational Education that *The Vocational Summary*, a monthly periodical which has been published by the Federal Board for more than three years, has been discontinued. Lack of funds is the reason given for the fate which has befallen the journal.

In the transfer of the Rehabilitation Division from the Federal Board to the lately established Veterans' Bureau, a large part of the funds which the Board has had at its disposal was transferred also. Since the joint funds have been used in the publishing of the periodical, this diminishes the amount available for this item to the extent that the Board can no longer withstand the total expenditure for its publication.

A GENERAL INDUSTRIAL SCHOOL

LAST February a general industrial school was organized at Meridian, Mississippi as a department in the high school. It proved to be so successful that it established itself in a short time as a permanent part of the Meridian school system.

This year its organization has been further developed and a course extending thru four years has been announced.

The course is open to boys over fourteen years of age. It is designed to give them a broad contact with various building trades in addition to the academic and social studies. Its purpose is to give the students an experience in a group of related trades which will lay a basis for their future vocation.

Fifteen hours of shop work per week is given for each of the four years. This work will include shop woodwork, carpentry, brick laying, concrete work, painting, plastering, paper hanging, etc. The shop work will be practical thruout.

An equal amount of time will be spent on classroom studies and drawing, the school being in session thirty hours a week. It has been announced by the school authorities that "this is not a school for the ungovernable, the dullard, or the lazy," but that intelligent, willing boys are wanted. H. N. Seney is the director of the school.

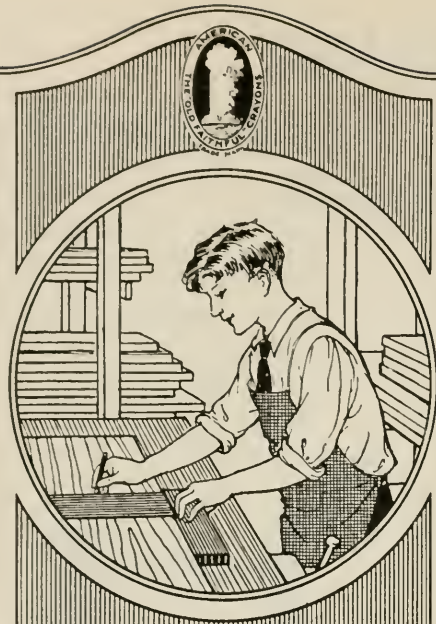

THE
"Old Faithful"
CRAYONS

Are ideal for
the purpose
of marking
upon paper
wood or metal

We have a special brand
for each purpose

THE
AMERICAN CRAYON
COMPANY
ESTABLISHED 1855
SANDUSKY, OHIO & NEW YORK

"Keeping Good Company"

Tells the Whole Story in a Few Words

(Small Booklet sent free upon request)

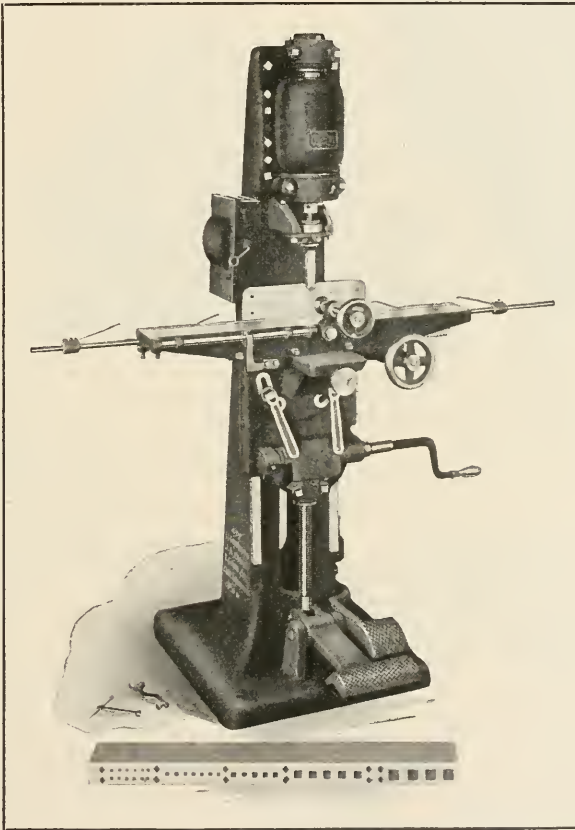

No. 472 Shaftless Motor Driven Vertical Hollow Chisel Mortiser

Mortises up to $\frac{3}{4}$ " square in hardwood and 1" in softwood.

Bulletin J-31 gives details.

J. A. FAY & EGAN COMPANY

ESTABLISHED 1830

World's Oldest and Largest Manufacturers
of Woodworking Machinery

730-750 W. Front St.

CINCINNATI, OHIO

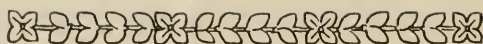

FIELD NOTES—(Continued)

NEW SCHOOL BUILDING AT
CORTLAND, NEW YORK

A NEW building which is to cost approximately \$350,000 is being erected at the State Normal Training school, Cortland, New York. While the manual training shops in this building are not planned particularly for the purpose of training teachers for industrial subjects or vocational work, ample provision has been made for shopwork in the junior high-school department of the training school. The plans for work in domestic science are similar to those for the manual training—to take care of the work of the junior high school and give opportunity to teachers to elect the subjects for special work in their preparation as junior high-school teachers.

On the first floor there is a woodworking room 28 ft. x 60 ft., a machine room, a printshop, and rooms for wood-finishing and for storage. The kindergarten rooms with a special room for construction work of various kinds are also located on this floor.

The domestic science department is equipped, in addition to the usual layout, with a well equipped laundry. This is used as a class room, but may also be utilized by students for private work by special appointment. There is also a small service kitchen for the open air school which is conducted in connection with this institution.

The plans further provide for a power laundry to take care of bathing suits, towels, etc., for the students of the school; and also for a cafeteria with kitchen, pantry and store rooms.

The entire third floor is devoted to art and mechanical drawing, and has a room for freehand drawing, one for mechanical drawing, and one for hand craft work, in addition to offices and store-rooms.

Harry L. Edick is in charge of manual training, Lillia Alcott of art, and Mary I. Raven of domestic science.

ITEMS OF PROGRESS

INCREASED ENROLLMENT AGAIN

The New Britain Trade School, New Britain, Connecticut, with Herman S. Hall as director, reports an increase in attendance of 30 per cent over last years' enrollment. Plans are being made for the erection of a new building to add to the facilities for training boys and young men in skilled occupations.

THE LATHROP TRADE SCHOOL

Enrollment in the Lathrop Trade School, Kansas City, Missouri, is nearly 75 per cent larger than it



See
these
books for
10 days
FREE

The FRENCH
Drawing Series

FRENCH and TURNBULL—
Lessons In Lettering—Book One—35 cents
per copy—\$3.60 per doz. The first of a
series of practice books with text, ex-
amples and exercises. Just published.

FRENCH and SVENSEN—
Mechanical Drawing for High Schools—
\$1.50. This vigorous new text is being
more rapidly adopted than all other
books of its kind together.

FRENCH—
Engineering Drawing—\$3.00. The stand-
ard college text book in its field.

FRENCH and IVES—
Agricultural Drawings and the Design of
Farm Structures—\$1.75.

FRENCH and MEIKLEJOHN—
Essentials of Lettering—\$1.50.

FREE EXAMINATION COUPON

McGRAW-HILL BOOK CO., Inc.
370 Seventh Ave., New York

You may send me on 10 days' approval

.....

I agree to pay for the books or return them,
postpaid, within 10 days of receipt.

Signed

School

Official Position ..

Address

.....

M. T. M. 11-1-21

The
Air-Drying
Art Enamel

Enamelac

A New Color
Medium.
Requires
No Firing

"Enamelac" is the ideal Color Medium for decorating Toys, Furniture, Picture Frames, Jewel Boxes, etc. It works on either wood or metal surfaces—is waterproof, durable, artistic. Complete "Outfit" in hinged cardboard box, 6 cans Enamelac, Turpentine, Shellac and 3 brushes.

Postpaid, \$3.00

Per 2 Oz. Can
30c

Gold and Sil-
ver, 45c

1 Pt. \$1.25

1 Qt. \$2.20

1 Gal. \$8.50



Made in
22
Beautiful
Colors

Send for Illustrated Circular and "Color Card" of "Enamelac"

THE PRANG CO.

1922 CALUMET AVE., CHICAGO
30 IRVING PLACE, NEW YORK

Do You Develop Ideals?

As Well As Craftsmanship?

Kewaunee is better—of course; more expensive—inevitably; but infinitely preferable for the school that develops ideals as well as craftsmanship. Our experience is at your disposal.

Kewaunee Manual Training Equipment

For many years, in all branches of science, Kewaunee Laboratory Furniture has been recognized as the American Standard. It has stood for Educational Ideals and Educational Efficiency.

Today Kewaunee occupies the same position in the Manual Training field.

For complete information address the factory at Kewaunee.

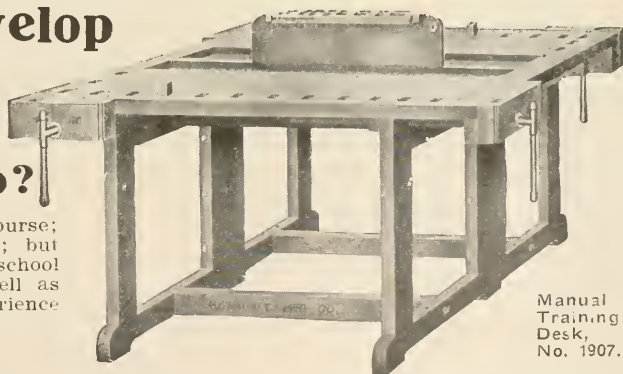

Manual
Training
Desk,
No. 1907.

Head and tail vises are securely bolted together, tool rack is elevated in center, and whole top is one piece. Bench can be supplied with drawer sections if desired.

Kewaunee Mfg. Co.
LABORATORY FURNITURE EXPERTS

111 Lincoln Street, Kewaunee, Wisconsin
New York Office, 70 Fifth Avenue

BRANCH OFFICES:

Chicago
Phoenix
Denver
Minneapolis
Columbus

Los Angeles
Kansas City
Little Rock
Spokane
Atlanta

Houston
Jackson, Miss.
Alexandria, La.
Oklahoma City
Toronto, Can.

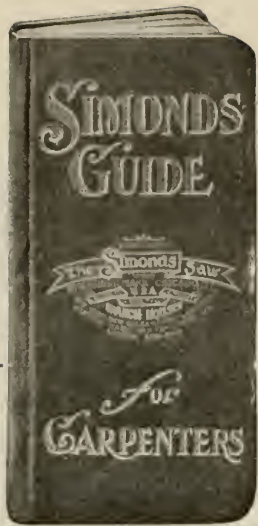

This Book Free To Instructors

It is vest pocket size, but contains practical information that a carpenter or wood-working instructor needs.

Included among the many bits of desirable information are rules for cutting rafters, making stairs and other designs. It also tells how to file and care for a hand saw.

Write for your copy today.

**Simonds
Manufacturing Co.**

"The Saw Makers"

FITCHBURG, MASS.

5 Factories

12 Branches

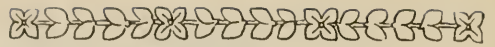

FIELD NOTES—(Continued)

was last year at this time. A. G. Norris, principal of the school attributes this increase to the unemployment situation and to the fact that the service of the school is becoming better known. The enrollment was 360 on September 10, with prospects of a great many to come within the following week. Evening school started September 26, and is given three evenings a week.

This school gives instructions in the following trades: electrical machinery, carpentry, brick masonry, printing, auto-mechanics, wood turning, drafting, and welding.

SCHOOL FACTORY PRODUCTION

The school shops of Muncie, Indiana, were used as a furniture factory during the summer months. During this time the shop instructors and a group of students produced a large quantity of furniture for the schools. The manual training and domestic science equipment of the new junior high school which has been erected was furnished entirely by this school factory.

Three reasons are given for the launching of this plan by Glen D. Brown, director of the prevocational department of the city schools, first, the cost saving; second, the desirability of using the school equipment; and third, the opportunity for employment of shop teachers and worthy students during the summer months.

There was an output of 104 large and 138 smaller pieces of furniture. On this a saving of \$1,187.13 was made according to the figures showing cost of production compared to the catalog prices of similar equipment.

ANOTHER TRADE SCHOOL FULL

The Boys' Trade School, Worcester, Massachusetts has between six and seven hundred students registered and has accommodations for only five hundred. A portable building has been added however, and this in addition to using hallways for class rooms has reduced the congestion to some extent. A new girls' trade school building is being constructed which will be ready for occupancy about December.

MANUAL TRAINING ADDED TO CURRICULUM

The schools of Harrisonburg, Virginia have added manual training to the course of study for this year. A. K. Hopkins is the new instructor who has charge of this work.

LARGE ENROLLMENT REPORTED

During the last summer session the industrial arts department of the Pennsylvania State College had sixty-three students enrolled. These were all

Manual Training Magazine

NOVEMBER, 1921

THE PROJECT PROBLEM

ALLEN D. BACKUS

Supervisor of Manual Training. Newark, New Jersey.

NOT long ago a group of school men from a part of the country which refers to Newark as, "out West," visited one of the large schools which is organized on the "alternating plan." Upon their return one of them wrote a "bread-and-butter" letter to the principal of the school. In referring to the shopwork he expressed the feeling that while the character of the work was splendid from a technical standpoint it was with a sense of regret that he saw all of the boys in a class working on the same problem. While skill was being acquired under this method he felt that the boys were being robbed of an opportunity to develop powers of initiative and self-expression.

The writer of this letter was so honest in his conviction that these Newark boys were losing one of the biggest things the manual training shop has the chance to give that I began to wonder if by any chance he was right, and whether the method we have been adhering to was not the best for the boy. Since then I have viewed the matter carefully from many different angles endeavoring to be unbiased in my judgments.

Of course it is nothing but that old question of whether to give the class all the same problem or to let each member of the class work on something which he chooses with the consent of the instructor. While this question is as old almost as manual training itself, nevertheless it is of the greatest importance that the successful manual training teacher should

have well founded convictions on this as well as other old and fundamental questions bearing on the administration of the shop. There may be strong arguments on both sides and it would perhaps be egotistical for any person to say, "I am right in this matter and the other fellow is dead wrong," but such questions as these are, I believe, of enough fundamental importance to make it extremely desirable that a manual training teacher should be able to say, "From my experience and as the result of my study of the question I believe this is the best way."

As far as initiative goes I am still unconvinced that the individual method does more for the boy than does the group method. In a class of twenty boys operating under the individual plan we will say that one decides to make a chair, another a table and still another a cart, and so on down the list. Each is perhaps told to bring in a drawing of the model he wishes to make. If the boy who has chosen the chair should bring in a crudely expressed drawing revealing the probable fact that he knows little of proportion, theory of lines, or of the principles of furniture construction it will then, of course, devolve upon the instructor in the due course of events to so lead and develop the boy's mind that from the almost useless drawing first presented there will result a conception of a chair, pleasing in proportion, graceful of line and properly constructed. Of

course while the instructor is doing this there are nineteen other boys waiting their turn to develop initiative and self-expression through the process of evolving good and original designs of tables, carts, etc. thru the suggestive powers of the teacher. If this teacher is a being with

The question which naturally comes to mind is, why should one boy develop his initiative thru the making of a chair, another thru the building of a table, and still another thru the manufacture of a cart? Of course one may say that this is the best way because it happens to be



FIG. 1. COASTER WAGONS—EIGHTH GRADE, BURNET ST. SCHOOL, ARTHUR T. GIBLIN, TEACHER.

a well developed sense of fairness he will only be able to give each boy his one-twentieth of the time allotted for the lesson. After each boy has a proper design from which to work, a similar lot of experiences will be the result of the construction itself. The boy who is making the chair must construct mortise-and-tenon joints, and unless the waste of lumber means nothing to the instructor, he will want to see the layout of one of these joints before it is cut, which if it should not be wisely proportioned will have to be changed, again by the suggestive method, to one which will answer the demands which will be put to it.

the thing he wants to make. I would agree with this if it were adult training we were considering, but in view of the fact that the education of grammar school boys is the question involved I must disagree. It has been my experience that boys of this age want to *make things* just what is of secondary importance, and in most cases, when the choice is left to the boy, these things are not genuinely original. I find it rare indeed to discover the boy who does not want to make the thing the class is making, and where this does occur it is very liable to be the fault of the instructor or in not presenting the project in a way

to make it appear attractive. I have reached this conclusion from the fact that where boys are required to pay for the materials used before the finished project can become the boys' own property, there are certain schools where the instructor will tell you that the boys in

double the sum which it has cost them. I can make only one deduction, and that is that the instructor is largely responsible for the difference in interest. There may be other elements which enter in, but they are usually of little consequence. And is it not fair to assume that the teacher

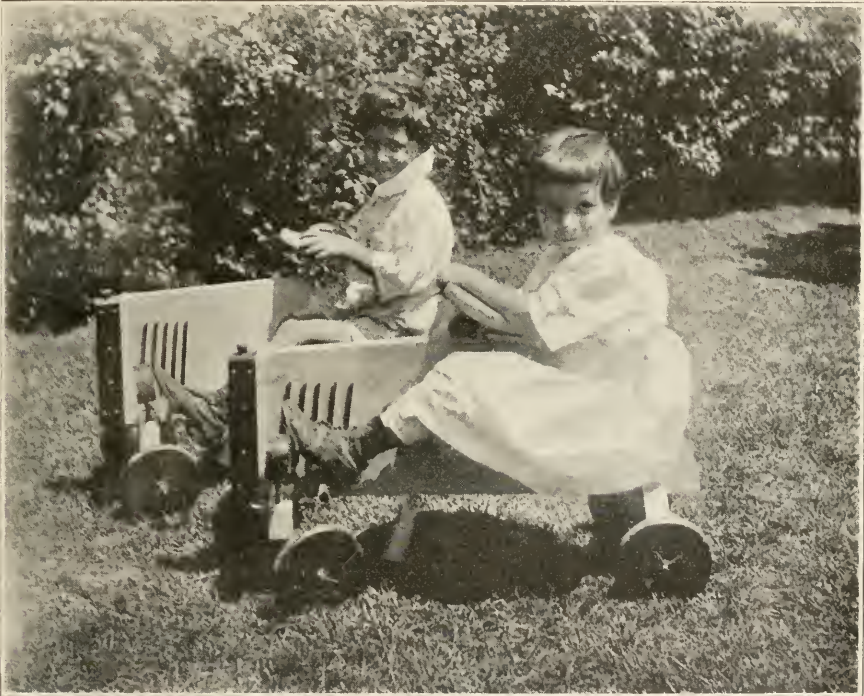

FIG. 2. KIDDIE KARS OF ALL KINDS MAKE GOOD PROJECTS. THESE TWO AND TWENTY MORE MADE BY EIGHTH GRADE CLASS AT LAFAYETTE SCHOOL, GEORGE BOWNE, TEACHER.

that particular section of the city do not seem to be able to get the money with which to pay for materials, and as a result there will always be a large per centage of finished models in the stock room, unpaid for. On the other hand, there are schools where the boys have no more money—in some cases, even poorer sections of the city—where the same models will be made and the boys will be waiting at the shop door with the money for the model, impatient to take it home. These same boys would not part with the thing which they have made if they were offered

who fails to arouse interest where another can provoke real enthusiasm over the project would also fail if a boy were given a free rein to make things of his own choice?

We are all rather well agreed that the acquirement of skill is not more than fifty per cent of the purpose of manual training. The teaching of many things thru the project method is one of the duties of the shop instructor. Where the choice of the model is left to the teacher this can certainly be accomplished much more successfully. I have little sympathy with

the teacher who is having a class of eighth grade boys make telegraph instruments and does not make use of the opportunity to develop somewhat the intensely interesting story of sending a message. The warriors of ancient times who signalled from mountain top to mountain top by means of their shining shields, Paul Revere in his attempt to carry a message which burned with patriotism, the laying

type will make the school shop one of the strongest factors in the education of the grammar school child. Edward Yeomans in his description of the school shop in, "Shackled Youth," has such a shop in mind. If you have not read that chapter do so by all means for it is full of inspiration and ought to make a better teacher out of any man. The trouble with the individual project idea as we



FIG. 3. MODEL AEROPLANES ARE FINE PROJECTS. THIS PICTURE SHOWS PART OF A CLASS AT THE ABINGTON AVE. SCHOOL, MELVIN BARNES, INSTRUCTOR.

of the Atlantic Cable which drew the continents together as if the distances which separated them and to which people had become accustomed had actually been lessened—all of these things and many others form nuclei for stories appealing to the imaginative elements of the boy's mind, and are of unquestionable value as they effect his reactions to history and geography.

I do not say that there is not a type of individual project instruction which is good. Indeed I believe there is such a type which is not only good but ideal. But before this type can become at all general we must have more teachers with great enthusiasm, clear vision as to aim and ability to inspire, as well as school boards and superintendents who are willing to spend more money. This

know it is that all these individual projects are disassociated so widely that, more often than not, chaos results. In the ideal scheme there would be individualistic expression of ideas but all of this centered about one large and worthwhile project. But all of this is still a goal to be sought; sometimes it would seem that the attainment of it is not near, but let us hope that it is nearer than we think, for it will be well for manual training if it is. One thing is certain and that is that if a teacher cannot take a class and with a class problem—an ideal one, we will assume—fill these boys with an enthusiasm and love for the thing they are making, and weave around it stories of the romance of industry, commerce and nature, then he will most certainly fail in doing this

thing with twenty or more different projects, many of which have nothing in common. The only possible desirable result will be the acquisition of a certain small amount of skill, which would probably result in either case.

not the teacher, and it is with this end in mind that I speak of the ultimate growth of the teacher.

Where the group method is employed it is very important that projects should be carefully chosen. Certain processes

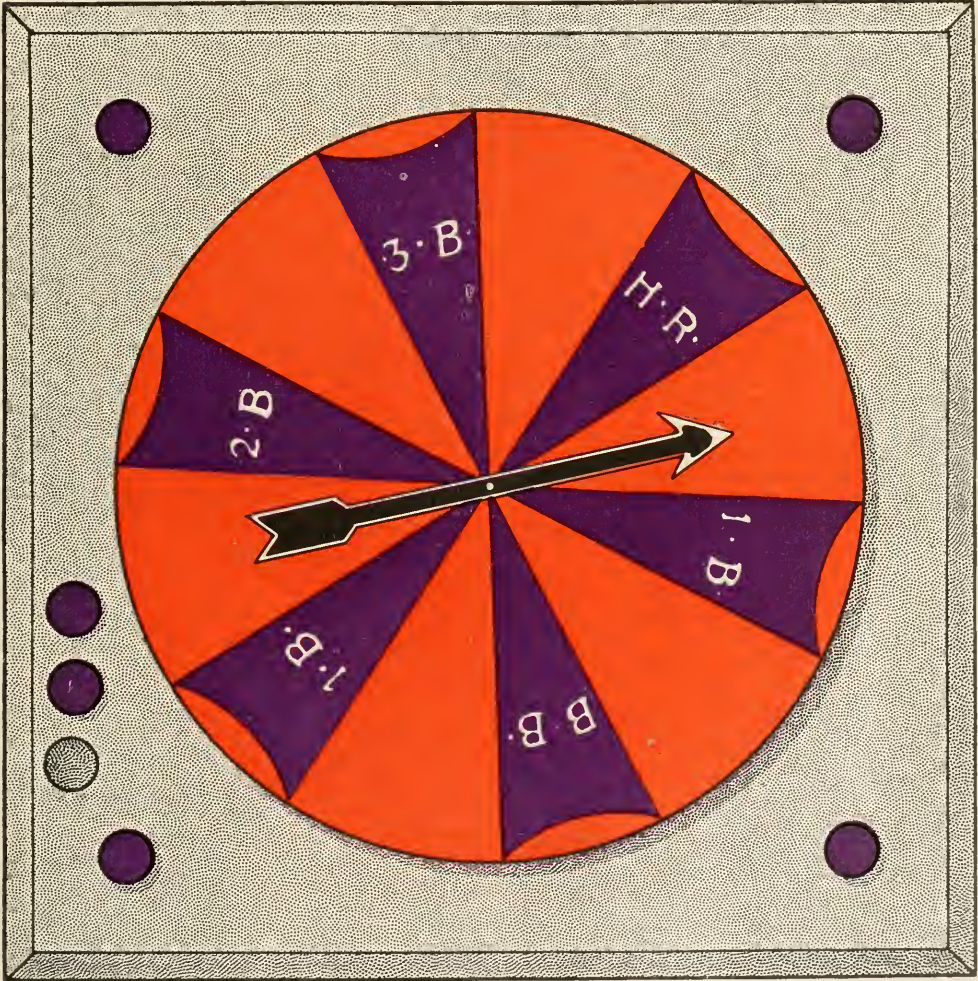

FIG. 4. BASE-BALL GAME.

It is my conclusion that around and thru the group method of instruction the teacher is going to grow much more rapidly than thru the individual method, and that in the meantime the boys as well are going to get more out of it. Of course we should think of the boy and

have to be taught, and how we have taught them! For instance, the squaring up of stock: we absolutely have to teach it; there is no question about it; but we do not have to teach it by having boys make bread boards and key racks and other things just as uninteresting. Try

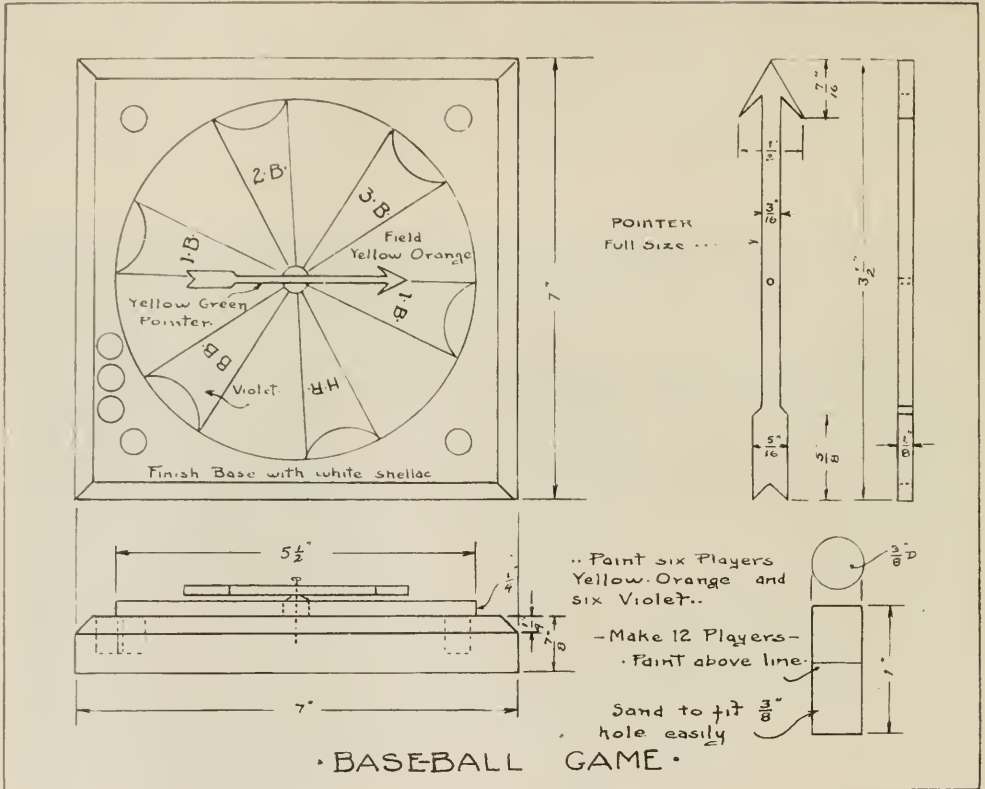

Fig. 5.

problems like the base-ball game shown in Fig. 4 and see if the boys do not learn the principles of squaring up stock more rapidly than ever before. And then instead of clinching the color theory, which the class has been learning up in the drawing room, in the mind of just one boy you will be clinching it in the minds of all of the boys in the class. Try such problems as the aerial spinner, Fig. 6, getting all of the class interested not alone in the making of it but in learning something about the principle of centrifugal motion, and see if you do not get better work and arouse more enthusiasm than you did when the boys made, "what they wanted to." Of course you will not have as spectacular an exhibition at the end of the year, but isn't it about time we gave less thought to exhibitions and more to the boys?

Note: For the use of readers who may wish to try out the problems shown in the foregoing article the following explanations are offered:—

THE BASE-BALL GAME

Many mechanical base-ball games have been put on the market. The trouble with the most of these is that, in an effort to make them include all of the features of the real game, the result has been complicated to the extent that children do not find the action rapid enough to satisfy their demands. In designing the game shown in Fig. 5, an effort was made to keep it as simple as possible and at the same time not to depart from the idea of base-ball. Before playing the game a scoring sheet is made. This consists of two rows of nine squares each, one row for each boy playing the game. The boy who comes up to bat in the first half of the first inning places a man at the home plate, which is the hole in the corner nearest to the series of three holes placed close together. He next gives the pointer a spin; he may spin it hard or not, as he chooses, just so long as it goes completely around at least once. If the pointer rests outside of any indicated play the man is out and is retired into

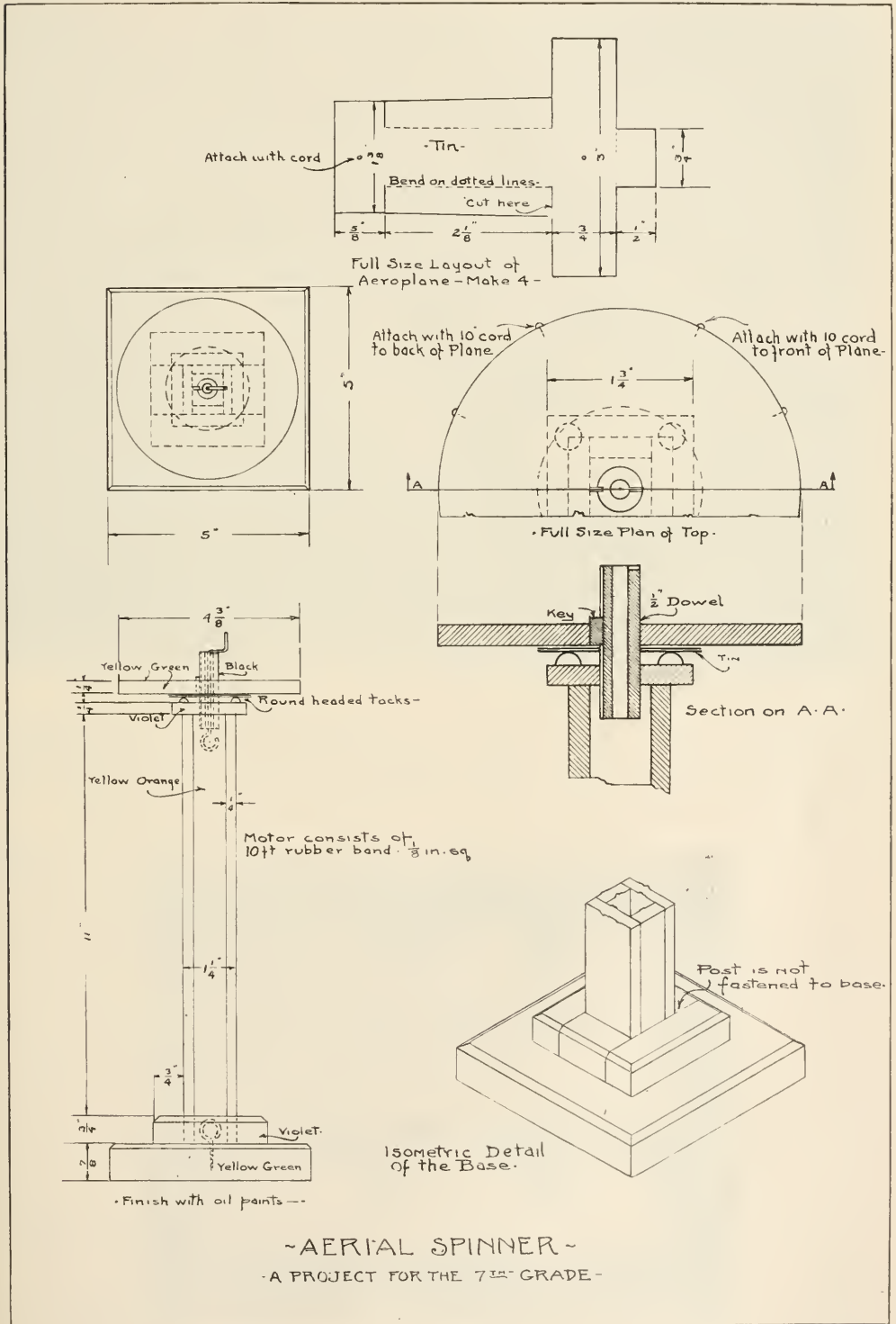

Fig. 6

the first of the three holes mentioned. If the pointer comes to a stop over an indicated play the play is made. For example, if the play indicated is I. B. the man is taken from the home plate and

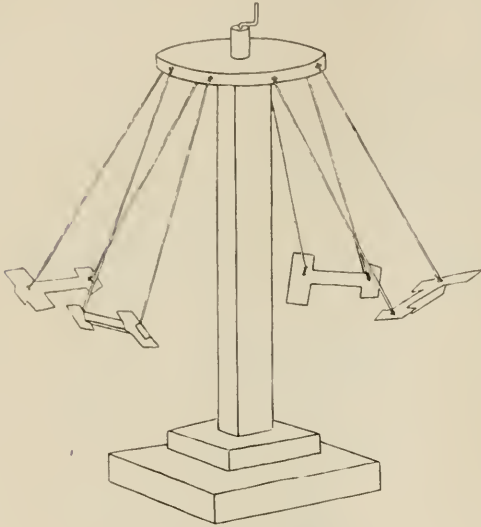

FIG. 7. AERIAL SPINNER.

placed in the hole representing first base; if the next man up should obtain 3. B. as a result of the next spin of the pointer he would be placed on third base while the man already on first would be forced home scoring a run. A home run is of course a score, and also scores any men already on bases. A base on balls puts the batter on first but does not advance a runner on second or third as would

a one-base hit. A runner on first is necessarily advanced to second by a runner who gets a base on balls. When three men have been retired the score for that side is marked down for that inning and the other boy begins his play. The game consists of nine innings. A third boy may act as umpire making all decisions which are close. If the game is made according to the working drawings it will be found that the scores are very much like real base-ball scores and that close and exciting games are the rule rather than the exception.

THE AERIAL SPINNER

The aerial spinner, Fig. 6, designed by Edgar A. Cole, instructor in manual training, Lafayette School, Newark, is a form of merry-go-round, Fig. 7, and has proved to be a great success. The motor is concealed in the hollow post which supports the circular piece at the top, from which hang the four tin aeroplanes as indicated in the drawings. When the motor is properly wound this top piece will revolve for about two minutes at such a speed as to whirl the planes at right angles with the post. It may be found necessary to provide a little lubrication between the tin washers at the top, as friction should be as nearly eliminated as possible. This problem makes a splendid Christmas toy.

OTHER PROBLEMS

The photographs, Fig. 1, 2, 3, and 8, have no connection with the problems for which drawings are shown, and are only illustrative of what the writer believes to be good projects thru which the right kind of manual training may be presented.

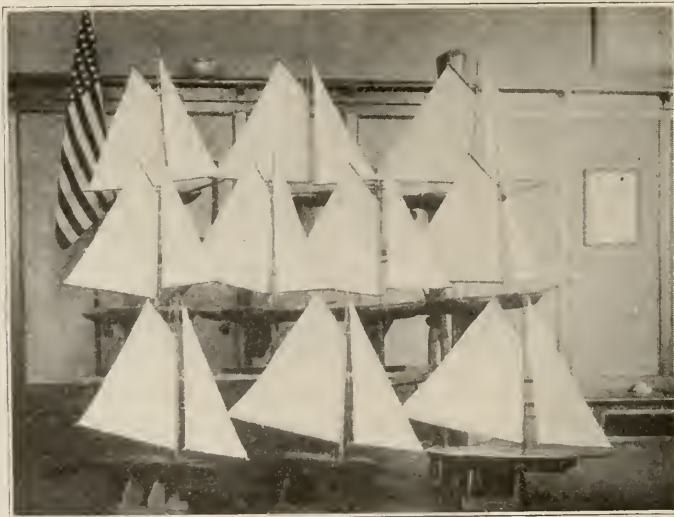

FIG. 8. EIGHTH GRADE, CLEVELAND JUNIOR HIGH SCHOOL.



FIFTH GRADE BOYS IN INDIANAPOLIS MAKING TOYS FOR CHILDREN OVER SEAS

PUTTING "PEP" INTO TOYS

HARRY E. WOOD

Director of Manual Training, Public Schools, Indianapolis, Ind.

PLAY is that inborn instinct which the child of every nation possesses. While the form of play may change, this instinct remains, to a greater or less degree, all thru life. Usually the first gift to the new baby is a toy of some description with which he can play, and as years add on age, interests change, and different kinds of toys are found to satisfy the desires and interests.

Prior to the world war, the United States looked to foreign countries for most of its toys, those imported far outnumbering those made in this country, but as in many other industries, when the foreign supply diminished, production in this country began to increase until now the United States ranks well

with other countries in its production of toys.

Due in part to manual training influence in the schools, the children themselves thruout the country have, in a way, become producers of toys. At the beginning of the reconstruction period, thousands of American children made thousands of children in foreign lands happy, with toys which were the result of their handiwork. Altho in many cases these toys made by the children have been somewhat crude, in most instances the results have been just as satisfactory as the factory-made toy, for too often the factory-made toy is lacking in workmanship and finish. This is due in part to the attempts of factories to produce

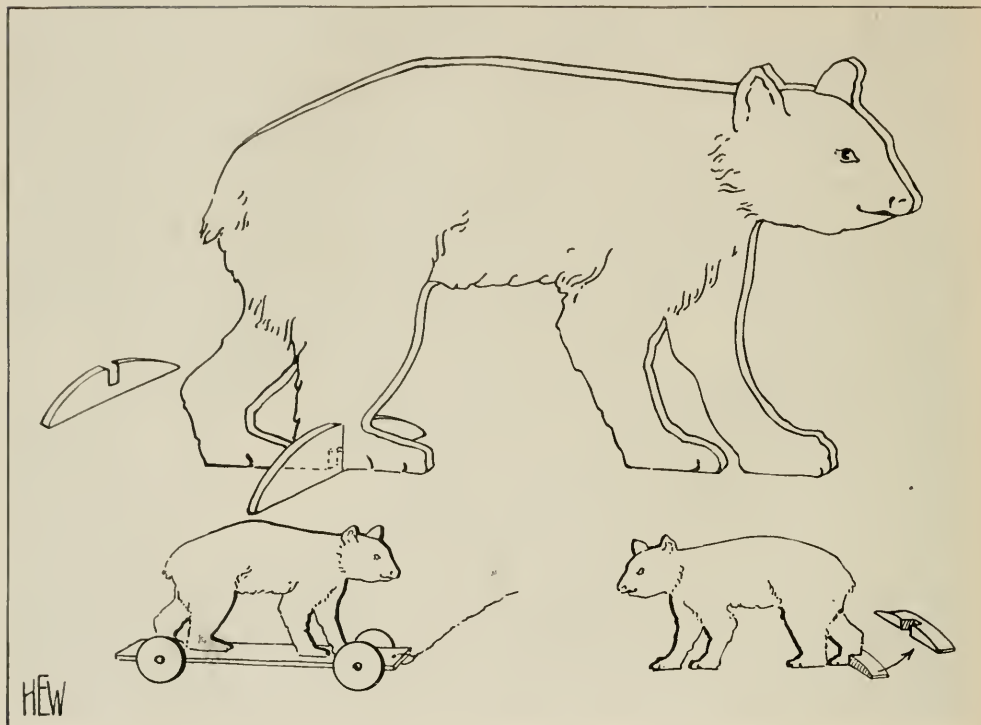

FIG. 1.

toys at too low a cost, rather than centering their efforts on the making of a product which looks well and which is durable enough to be played with. Good or bad as the toys may be, the children will continue to need them and the interest in self-made toys which has, thru necessity, been created will continue and develop.

For a number of years, children in the intermediate grades have been making *stationary* toys—silhouettes of animals or figures sawed out of thin wood and mounted on a base but for the most part the results have been rather crude, due partly to poor design and the lack of color. With the advent of tempera colors in the schools, it has become possible to have something more than mere silhouettes in wood, for here is a medium, easily mixed and easily applied, which produces that which is always attractive to the child—color.

If a design such as here illustrated, Fig. 1, traced on a piece of basswood $\frac{3}{16}$ " or $\frac{1}{4}$ " thick (or upon a piece of old cigar box), then sawed out with a coping saw, edges smoothed, first with a half round file and then with sandpaper, the whole painted with tempera color of a suitable color and hue, lines which will give character and detail drawn inside the silhouette with India ink and the whole shellaced to hold the color and give it gloss, a very creditable toy is produced. It is possible to make this toy still more attractive by mounting it upon a base so that it will stand up or by adding wheels (made of cross sections of broom sticks or dowel rods) so that it may be pulled around. The illustration also shows other ways of making stand-ards for the toys.

Such a toy can be made into a *movable* toy by transforming the design as shown in Fig. 2, and cutting out each piece

MOVABLE BEAR

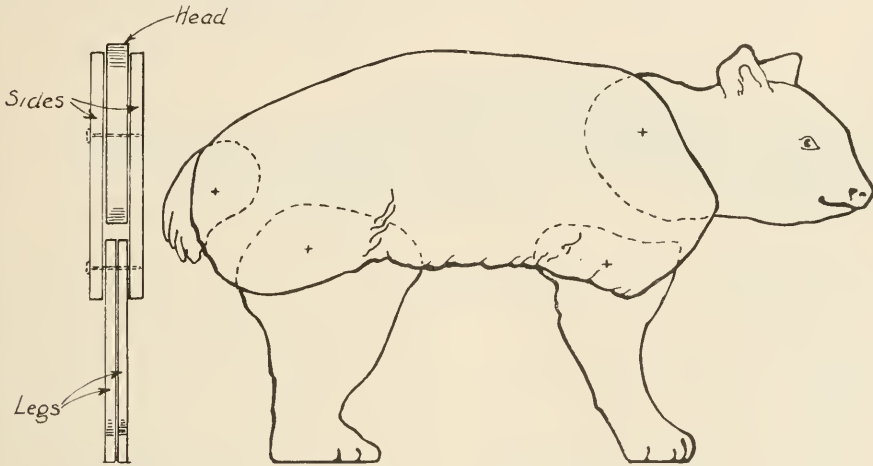

HEW

FIG. 2.

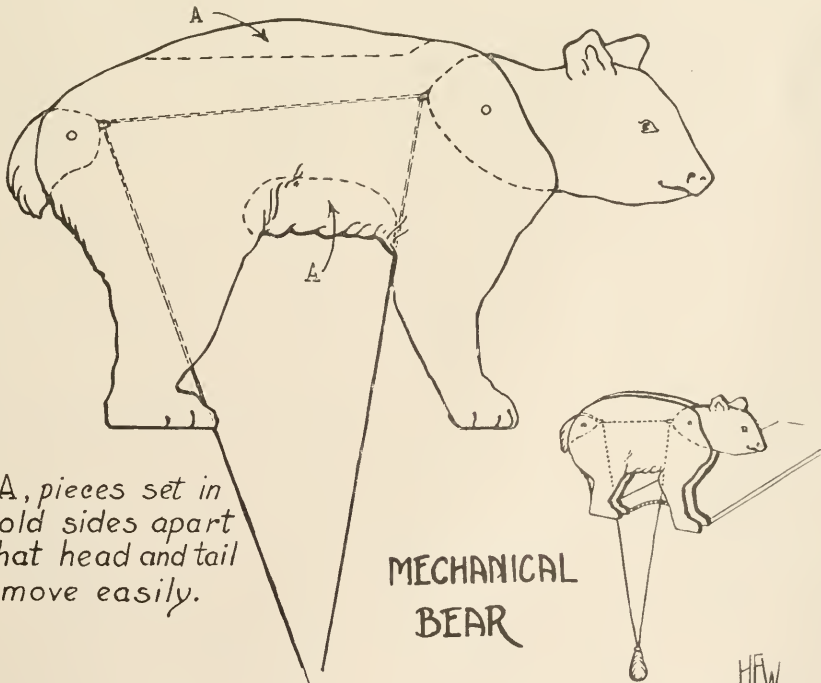

A-A, pieces set in to hold sides apart so that head and tail can move easily.

MECHANICAL BEAR

HEW

FIG. 3.

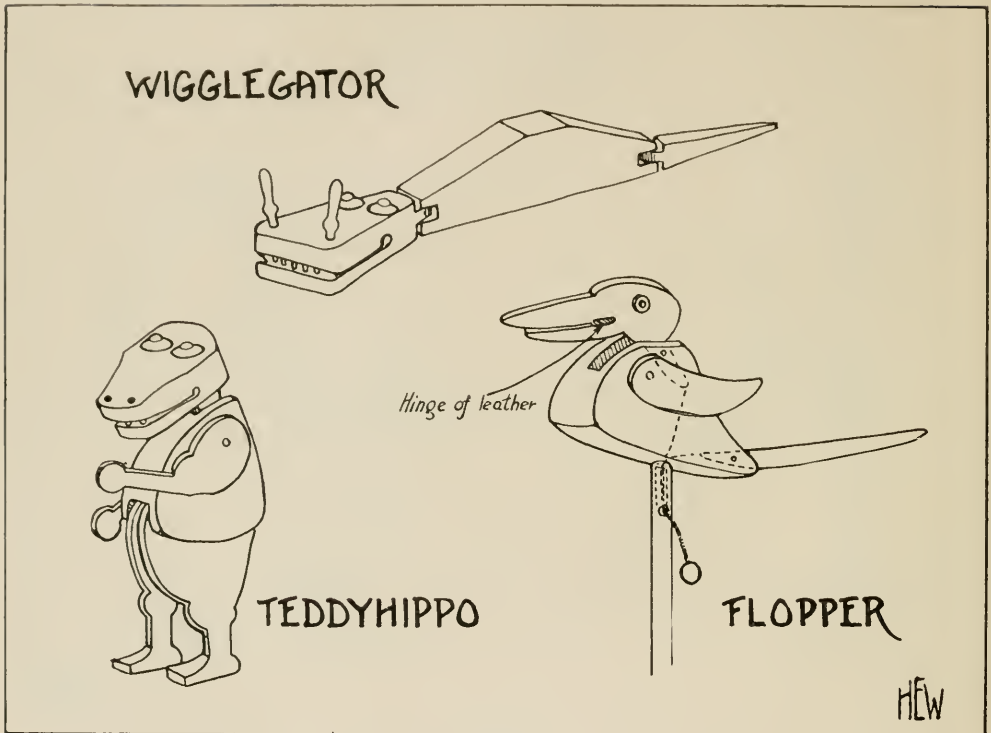

FIG. 4.

separately. The mechanics of determining just how much wood will be needed to make the animal jointed, and just where the pivot on which the parts turn, shall be placed, makes an excellent problem. In case the toy is an animal form, it is advisable to make the body of two pieces of wood $\frac{1}{8}$ " thick and the head and tail out of wood $\frac{1}{4}$ " thick and the legs out of $\frac{1}{8}$ " material. In this way, the legs when mounted between the two sides, form a thickness equal to that of the head and tail.

Still more interest may be added by transforming the toy into a *mechanical* one, by developing it in some way so that by pulling a string, rocking a weight or snapping a spring, it will move, jump or kick. Many familiar toys such as the feeding chick, the wood choppers, the jumping jack, the tumbling clown, and so forth, have already been brought to

public notice. The illustrations shown in Fig. 3 are merely for the purpose of showing how it is possible to take any toy pattern of either the stationary or movable type, and transform it into a mechanical toy.

The old idea of the balance-weight can be applied to any toy having a head and tail, by connecting them as shown in Fig. 3. Some experimenting will be necessary to locate the exact points where the cord should be attached. The shorter the distance between the points where the cord is fastened and the pivot on which the head and tail moves, the greater will be the action as the weight swings. Arms or legs might also be connected in such a way that they will move as the weight swings.

The making of such toys as those mentioned and the one illustrated, while possessing much merit, after all are

imitations, for no bear ever had a back at right angles to his sides, or sides that are perfectly flat, but making them so is permissible because it is a toy which is being produced. In our toy-making we

Why then is it not perfectly proper in toy-making to take such materials as are available, fashion them into shapes suitable to the material, creating a toy with eyes that snap, with a tail that wags

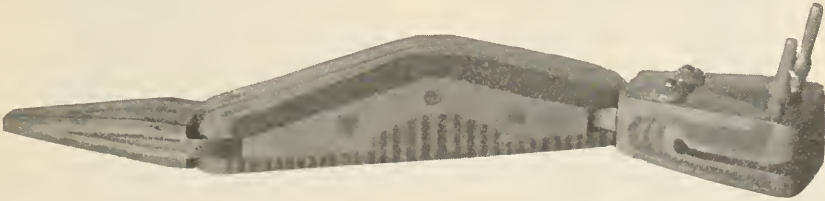

FIG. 5. THIS IS PAINTED IN THREE HARMONIOUS COLORS: THE LIGHTEST SURFACES ARE SOFT VIOLET; THE DARKEST ARE DULL ORANGE; THE MEDIUM ARE GREEN. IN REAL LIFE THE VIOLET IS THE DARKEST COLOR.

have been so in the habit of imitating things which we have seen that we have overlooked a phase of the work which offers all sorts of possibilities in the development of initiative and inventiveness. It took a Palmer to create a Brownie. Up to that time no one ever thought of such big headed, spindle legged, pointed toed creature. It took an O'Neil to captivate the country with her Kewpies. Burgess is responsible for illustrations of characters the like of which have not been known before but we now know them as Goops. Gruell's Quack Doodles and Dannie Daddles are familiar toy pets in many nurseries.

or with a head that nods, or perhaps a body that wiggles, and then call it by some special name of our own conception? It might crawl like an alligator, Fig. 4, and still bear no resemblance to one—or to any other animal for that matter, but nevertheless be a perfectly good animal for Toyland.

Instead of building up toys altogether out of thin wood, much interest may be added, by fashioning parts of them out of thick material as illustrated in Fig.5.

"Wigglegators," "Floppers" and "Teddyhippos" are only a few of the mysterious toys waiting to be born into Toyland.

TEACHER TRAINING IN NEW YORK CITY

FLORENCE N. LEVY

Secretary of the School Art League of New York City

SO MANY complaints have been registered against present-day education that it is worth while to note the efforts that are being made by the most progressive teachers to train themselves and to keep abreast of the new and approved methods of teaching.

July is the great month for "teacher training." Thousands of teachers from every state of the Union have gone

direct from their classrooms, where they have been "giving out" for nine or ten months, to the great universities where they will "drink in" knowledge from professors of world-wide reputation. Columbia and New York Universities, City and Hunter Colleges attracted some 20,000 students to New York City during the summer of 1921.

The amount of work that can be ac-

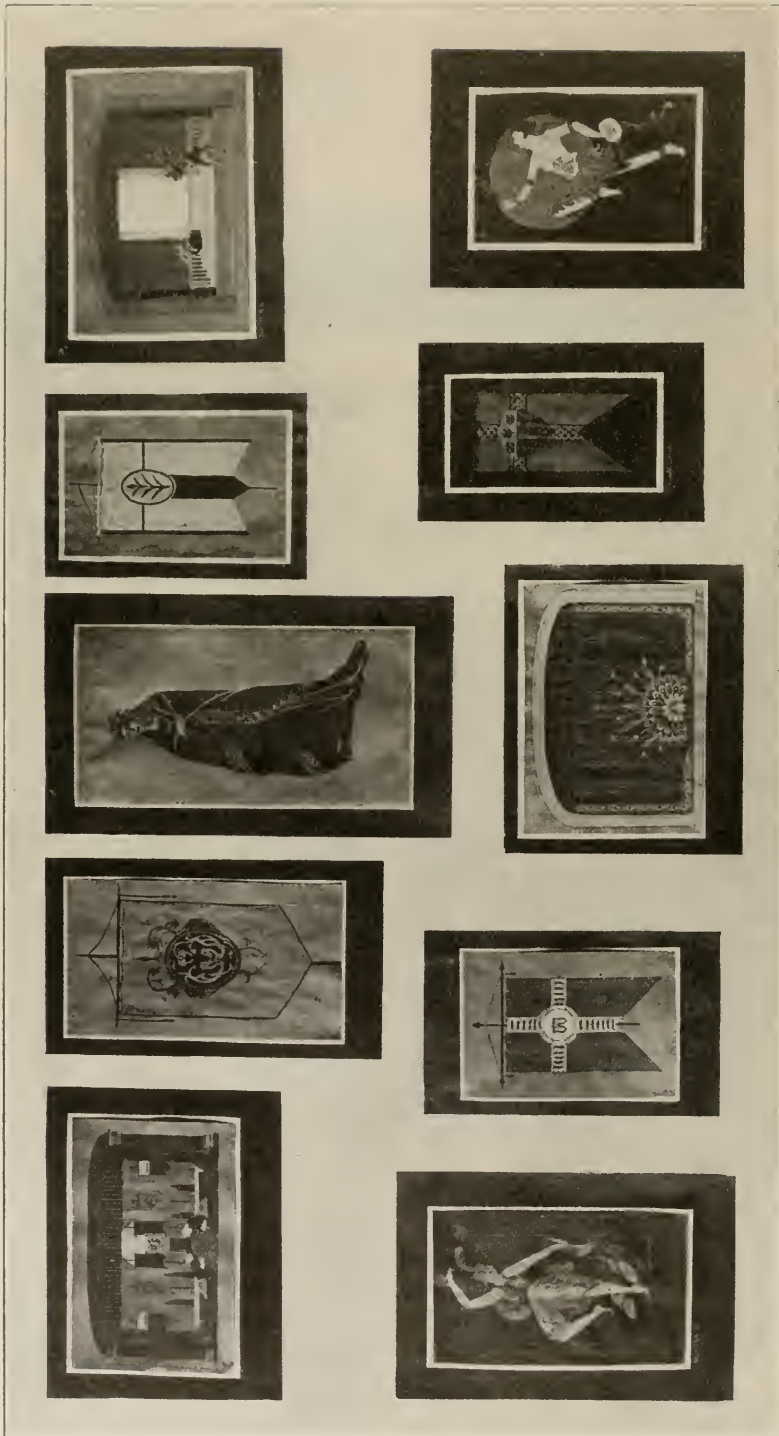

FIG. 1. DESIGN WORK DONE IN SUMMER COURSE FOR TEACHERS AT NEW YORK UNIVERSITY.

completed in from three to six weeks of intensive training, is quite remarkable. Witness, for instance, the accompanying illustration, Fig. 1, from the three-weeks course in design and demonstration drawing conducted at New York University by James Parton Haney, director of art in the High Schools of New York City. The course in design takes up the de-

need during the season, for art is taking its place as part of every-day life, and the pageant, the drama, and the posters that announce them to the public, depend for their success upon the close co-operation of the art department with the English, the dressmaking, and the music departments.

"The idea behind this course," said Dr.



FIG. 2. TOYS MADE BY NEW YORK TEACHERS OF SHOPWORK UNDER THE LEADERSHIP OF THOMAS AUSKIS.

velopment of decorative units from natural forms, the application of derived units to definite problems, and the adaptation of these motifs to various materials such as wood, textiles, china, glass, iron, etc. The problems included a poster announcing a film production, a scarf end to be executed in batik, and decorative studies made for pageantry, such as a stage-set, drop curtain, banner, and costume. These are designs that every progressive art teacher is likely to

Haney, "is that of a post-graduate school in which supervisors and art teachers can review school organization and teaching in the light of their own experience. With the feeling, also, that aesthetic principles are best learned thru practice, design is taught not merely as theory but thru practical problems to be solved in individual fashion. Planned for specialists already trained in the elements of drawing and design, it aims to forward these teachers in every way to a clearer realiz-



FIG. 3. EXHIBIT OF WORK DONE BY NEW YORK TEACHERS OF SHOPWORK.



FIG. 4. MODEL YACHT RACE OF BOATS MADE BY
NEW YORK TEACHERS OF SHOPWORK.

ation of what may be termed the professional study of art teaching in elementary and high school."

That teacher training is not confined to the summer is evident from the series of study groups organized last winter by the teachers of shopwork in some three hundred elementary schools of New York City. Each group was under the leadership of a member of the corps who was particularly fitted for this guidance by experience, special knowledge, and personality. The subjects included metalwork, model yacht design and construction, cement work, wood carving, toy making, Fig. 2, and chart making.

The purpose of these classes was to prepare the teachers to carry out a new course in shopwork that would come close to boys' real constructive interests. An exhibit of work done was held in the Murray Hill Vocational School during April, Fig. 3.

To still further interest the corps in the things boys like to make and play with, an outing was planned by Albert W. Garritt, the acting director of shopwork, which was held in June at Leonia, N. J., where there is an athletic field and a small lake. The program of the day included a model yacht regatta in which thirty boats, Fig. 4, built by the men themselves, competed; a kite contest in which a few scientific and grotesque kites were flown; two model aeroplanes were tried out; and there were stilt races, Fig. 5, an archery contest, and a quilt pitching tournament. The day was ended by an address by Raymond J. Knoepfel, president of the Rotary Club of New York City, who made a plea for helping boys of a large city to become substantial men of affairs by giving them an opportunity to develop their hobbies and getting them interested in clean sports.



FIG. 5. OUTING OF NEW YORK TEACHERS OF SHOPWORK AT LEONIA, N. J.

AN AUTOMOBILE SHOW

LESTER C. SMITH, Manual Arts Department, The Chicago Latin School

INTEREST should be the dominating motive in all study. Especially is this true of shopwork. In our shop the dearest prize, and one which is earnestly sought for, is an extra hour's work in the

toy airplane company; some wooden wheels of several sizes from a toy manufacturer, others were turned on the lathe. Tin, copper, wire, nails, dowels, upholsterer's tacks, and many devices were



shop. This privilege is granted the one who does the best work in our upper grade classes.

We have had several exhibits, shows, bazaars, etc., but the one exciting the most interest, zeal in work, and even inventive genius was our automobile show held March 9, a picture of which is shown herewith.

Interest was first aroused over the small Marmon models exhibited at the big auto show in the Coliseum. Much talk is always the first indication of a new interest; plans and work follow. About February 1st it was decided to hold an auto show in the shop, and officers from the second to the seventh grades were elected or appointed.

It now became my business to get materials needed, a great many being suggested by the children themselves. Most of the cars were sawed, planed and chiseled from soft pine 2" x 2" stock. Wheels with rubber tires were obtained from a

used for steering wheels, springs, exhaust pipes, lights, axles, brakes, seats, etc. Some were covered with tin, one with tin foil and all painted many very bright colors. Sport and racing models predominated. Tops were put on some and several were upholstered in leather.

So many ingenious devices were used that it finally became necessary to inaugurate a patent bureau. A patent lawyer was interested when appealed to and gave us some blank forms which we made up and issued to the young inventors. A license bureau was developed and license numbers issued.

Over fifty cars were entered in the show and many others finished too late for entry. The morning of the show six fathers, eight mothers and about fifty boys were outside the door waiting to be let in at eight-thirty. During the day about one hundred parents, besides many friends, visited us and the show was declared a success.



EDITORIAL REVIEW FOR THE MONTH

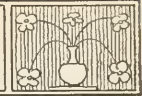

TOY DESIGNING

IN DEVOTING this number almost exclusively to toy-making, the editors believe they are encouraging a wholesome tendency in present manual training work and, therefore, rendering a real service. The limited space of this column will not allow an extended statement of the reasons for this opinion. In fact, so much on the subject has been printed in this Magazine in the past that argument is not needed now. It is appropriate, however, to call attention to one feature of toy-making that is given some emphasis in this special number:

Toy-making that stops with reproducing what someone else has made falls short of its highest possibilities. In the earlier stages of the work and under certain conditions well known to experienced teachers there is nothing better to be done than to reproduce a toy that has been designed by some other person—to make a toy from such working drawings as are given on the pages of this issue, for example—but such reproduction should lead, whenever possible, to more creative work—to designing toys. This amounts to little more than adapting ideas found in one or several toys to a different toy, yet this is just enough to make the process educative. The teacher's part in this process of designing is to assign or approve or definitely state the problem and then suggest sources of ideas which, if applied properly, will bring the desired results. Mr. Wood's article in this issue is especially rich in such ideas. The French toy in the Projects Department is also suggestive. In fact, if a student has a problem in mind to solve he may find ideas in many of the other photographs and working drawings.

It is not necessary here to classify those ideas, but, in passing, it should be noticed that they include ideas of beauty as well as utility—fine contour and color, as well as mechanism that gives life and “go” to the toy. The purpose of toys is to give pleasure, and pleasure comes thru beautiful shapes and colors as well as lifelike action.

THE WOMAN'S INSTITUTE OF DOMESTIC
ARTS AND SCIENCES, SCRANTON, PA.

AMOST interesting and significant educational event occurred in Scranton, Pennsylvania, on Thursday, September 29, 1921, in the dedication exercises of the Women's Institute of Domestic Arts and Sciences. This is the most recently developed of the subsidiary agencies of the International Textbook Company, the others being the International Correspondence Schools, and the International Supply Company.

The Woman's Institute was founded to supply an urgent human need. Women everywhere wanted training in the housewifely arts, dressmaking, millinery, and cookery, yet because of family cares, lack of means, or the necessity of earning their own living, they could not leave home to go to school. If they were to learn, the school must come to them.

A REMARKABLE GROWTH

The Institute has had a remarkable growth. The first student enrolled in February, 1916; by January, 1921, there were nearly 95,000; and in September the 125,000 mark was passed. Instruction is carried on by correspondence methods exclusively, and the only means employed for bringing the Institute to the attention of prospective students is advertising in women's magazines of national circulation. There is not a single field representative or solicitor-salesman on the payroll. There are stu-

dents in every state and in 38 foreign countries.

Thus far the Institute has developed three courses: (1) Sewing, dressmaking, and tailoring, consisting of 38 lessons, containing 1,800 pages of text, and 2,100 illustrations; (2) Millinery, 25 lessons, 1,200 pages, 1,400 illustrations; (3) Cookery, 26 lessons, 1,300 pages, 1,000 illustrations. More than \$150,000 were expended in preparing these courses and lesson papers. The spirit of the instruction is admirably expressed in the following statement:

More and more the world is coming to recognize that business is only another name for service—and that business is most successful in the truest sense of the word which renders the most service or the service of greatest value. And this is especially true of the Women's Institute, where nothing tangible is manufactured, where the only thing offered is educational service. It is a service designed and intended to give the student the clearest possible understanding of the particular subject she may be studying. It is based, of course, on the textbooks, but these textbooks are only the basis for the personal service that aims to make the educational service of the Institute conform to the particular individual needs of each student.

THE DEDICATION EXERCISES

The dedication exercises were simple, yet very impressive, and were held in the afternoon in front of the main entrance of the building. Hon. William C. Sproul, Governor of Pennsylvania, presided, and the principal address was delivered by Dr. Thomas E. Finegan, state superintendent of public instruction. The key to the building was presented by William S. Loundes, head of the school of architecture of the International Correspondence Schools, and architect of the building, and accepted by George G. Brooks, for the board of directors.

In the evening more than 850 guests assembled at a dinner given in the auditorium of the town hall, after which the following program was presented:

"Vocational Education," by Dr. William T. Bawden, United States Bureau of Education; "Inspiration," by Mrs. Anna Steese Richardson, of the *Woman's Home Companion*; "Five Years," by G. Lynn Sumner, vice-president, Woman's Institute; "Home Training," by Miss Mary Sweeney, president, American Home Economics Association; "Morale," by Brig.-Gen. George Richards, United States Marine Corps; "Our Students," by Mrs. Mary Brooks Picken, vice-president and director of instruction, Women's Institute; "Teachers," by Dr. Albert L. Rowland, State Department of Public Instruction, Harrisburg, Pa.

At the close of the program the guests were given a most unusual treat in the form of an exhibition of a motion picture film of the exercises which had taken place that afternoon, and another film showing the exercises at the time of the laying of the corner stone in June, 1920.

THE BUILDING

The building is very attractive in appearance, and stands out prominently in the landscape as viewed from the neighboring hills. It is described as "a free treatment of the collegiate Gothic style of architecture," and is justly referred to as "a monument to the growth and enterprise of the institution."

Representing a total outlay for construction and furnishings of over \$1,000,000, in addition to the value of the site, the entire five floors and basement, including over 68,000 square feet of floor space, are given over to the work of the Woman's Institute. These activities consist of the correspondence and clerical work incidental to the maintenance of contact with the students, the correction of lesson papers submitted and assignment of new lessons, maintenance of students' records and other files, as well as stocks of materials and supplies used,



THE NEW BUILDING OF THE WOMAN'S INSTITUTE OF DOMESTIC ARTS
AND SCIENCES, SCRANTON, PA.

and administration. The employees include upwards of 200 instructors, all of whom have been trained in special courses planned by the Institute itself, and more than 300 clerical and other assistants who are necessary to support the actual work of instruction.

AN INSTITUTION TO BE STUDIED

An institution which has met with such marked success in serving the needs and solving the problems of girls and women is worthy of careful study by those who are responsible for the forms which public education takes and the types of service which it attempts to render. In his address following the dinner Dr. Rowland aptly said:

It seems to me that the educational forces have too long kept themselves in a strange academic isolation, insisting that those who would drink at this fountain of life must come to them, and declining to step out into the great world to carry to the hungry thousands the things which alone can feed them. Those of us who are engaged in the

great business of public education must sit at the feet of these brave pioneers who have had the courage to explore this new country and in the face of almost insurmountable difficulties to present to us a new teaching process—the correspondence method—the refinements of which make us blush with shame.

This Magazine takes pleasure in congratulating President Weeks, Mrs. Picken, Mr. Sumner, and their associates, upon the consummation of their dreams and plans in this beautiful building dedicated to the educational service of womankind, and in joining with others in the expression of good wishes for even better things to come.

NEW COURSE STARTED AT WEST VIRGINIA UNIVERSITY

THE West Virginia University is establishing courses in industrial education and has called Edward S. Maclin to take charge of this new work. It is proposed to give at the University a course in vocational education designed

primarily for persons who are to become school administrators, a course in the organization and administration of industrial education and possibly one in methods of teaching industrial education. Besides the work at the University, teacher-training classes will be conducted in other centers in the state.

Professor Maclin is a graduate of the University of Tennessee. While there he spent three years in engineering and



EDWARD S. MACHIN.

one in education. Since then he has nearly completed the work for the M. A. degree at the Peabody College, Nashville.

His experience has been two years as a machine designer and draftsman; two and a half years as a teacher of woodwork and drawing in the Atlanta, Ga., high schools; four years as teacher of descriptive geometry and engineering drawing, University of Wisconsin; three

summers teaching woodwork and drawing to teachers; three years as head of the drawing department, Technological High School, Atlanta, Ga.; and during the past two years he has been engaged in vocational education work, first as professor of industrial education at the University of Tennessee and acting state supervisor of industrial education, then devoting all his time to the state work, and finally, in U. S. Government work under the War Department in organizing courses and training teachers for the vocational education of soldiers.

GEORGE W. EGGERS GOES TO DENVER

GEORGE W. EGGERS has resigned from the directorship of the Chicago Art Institute to become the director of the Denver Art Association, an institution with which he has been connected in an advisory relation for several years. His new position will involve the building of a new museum for that city. The Denver position is especially attractive to Mr. Eggers because it includes an arrangement whereby the director is given greater opportunities than in Chicago for carrying out certain plans for personal work. His leaving is a very real loss to Chicago and vicinity. The *Art Institute Bulletin* says of him:

Mr. Eggers' standards have been high. The consequence has been that everything with which he has come in contact has taken on artistic merit.

Those who have been privileged to work with him deeply regret his departure. His tact in imparting constructive criticism and his delightful way of sharing with his co-workers his experiences and ideals have endeared him to his staff.

Education should enable all people to share in the great intellectual conquests of humanity. Every citizen, whatever his calling, should know something of the history, literature, science and art of the past and the present. The man who toils with his hands must understand the science of his craft; and the man who toils with his head must value the human need of artisanship.

—UTAH'S EDUCATIONAL PROGRAM.

A POINT OF VIEW

AFTER a fellow has signed his name all day to communications written by others, has analyzed contracts involving thousands of dollars, has met people who want jobs more often than he has met jobs that want people, he may go out in the park and sit with the unemployed. While he may have a feeling of satisfaction that it is not necessary for him to stay there all night wrapped up in newspapers as do the men in Bryant Park, New York, at the same time he has perhaps enough on his mind to match the regular bench seekers who have less in physical comforts.

I am thinking how extremely complex are the expressions of life. What various opinions there are regarding the relationship of labor to capital, of problems of taxation and tariff, of the points under consideration in the reduction of armaments, of points regarding politics, business, religion, and education.

Educational theory and procedure are no exception to this complexity. In fact, they are more complex because they involve the mental, physical, and spiritual expressions of life. They are less easily measured and less easily formularized than taxation, wages, or tariff. In fact, educational theory and procedure approaches in difficulty of solution the questions of religion, justice, and truth.

Education, fortunately or unfortunately, is not yet an exact science. There is no educational formula as simple as Ohm's Law that C equals E over R . More than one Einstein has upset educational gravitation laws.

Somehow, education as practiced is a reflection of the economic and social conditions as they are. And that is right. On the other hand, education as idealized is a reflection of what economic and social conditions should be. And that is right. But these two rights almost

make a wrong, in that it keeps us constantly stirred up. And yet again, this same wrong is right, because unless we are stirred up we do not progress. We cannot invent machines to do things which we do not yet know need to be done. It is only when the necessity arises that the machine appears. Machines do not create necessities; they are a result of them. Perhaps education cannot create. Perhaps it must always be a reflection.

It may be that education cannot be epoch-making. It may be only epoch-following. Have religion, art and literature been epoch-making? Have they not been the reflections of other phases and expressions of life? Athens had an art, a music, a religion, and a literature directly correlated with the industrial and bodily slavery of her people. The Middle Ages had expressions of cultural and vocational living in exact accordance with its standards of economics, politics, and vocations. The factory village in England before the industrial revolution was a unit based upon a consistency of relationship between tool-owning, rent-paying, franchise-giving, library service, public school system and church attitudes. If they had industrial slaves the houses were owned by those who made them slaves. If they had ignorance in workers they had no library service. If they were not living in a democracy they had no public school system. In short, things fitted together.

A new England came out of the new machine. New social problems arose from industrial issues. Notice that the industrial issues did not arise from new social problems, and notice that educational issues arose because of new social and industrial issues.

Likewise, the Colonial period of New England was also a complete unit. There

was one store, one church, one blacksmith shop, one public common, one church sociable, and one school. And the school was a minor affair. It was the home, church, street and shop that gave exploring and exposure courses. It is a trite saying that apprenticeship was the vocational education system. Think of a period with no vocabulary of dieticians, efficiency experts, personnel, I. Q.'s, tests, ratings, coefficients, elimination, urge, relativity, specializations, automatics, division of labor, illiteracy, defectives, etc. If a person was, for example, mentally deranged, he was called crazy. If he was mentally deficient, he was not bright. If he was tubercular he was called a consumptive and kept in a closed room. If he was feverish he was given hot milk and refused ice cream. If he had epilepsy he was bled. If he had an ear ache there was no cutting of the drum under any consideration. If he had appendicitis it was called inflammation of the bowels. If his feet were sore they gave him large shoes. If he shivered they had him wear flannels. If he had ideas they put him in the stocks and whipped him. If he had visions they called it witchcraft and tormented him. If he practiced divine healing they imprisoned him. If he proposed a river boat run by a steam engine they laughed at him. In other words, they sewed him up mentally all the year and physically in the winter, and gave him molasses and sulphur in the spring. Their narrowness of vision was not limited to any one expression of life. The Colonial took his sulphur as seriously as his religious revival, his punishment as religiously as he did his Saturday sundown prayer. His literature was as narrow as his astronomy, and his notions of education were as broad as his ideas of psychiatry, psychology, and psycho-analysis.

The point I am making is that he was

consistent. "Early to bed and early to rise, etc." originated with him in the days of candles. Candles cost money, so naturally they followed the movements of the sun. "The early bird catches the worm" originated before the day that we thought of worms as being as worthy of an expression of life and usefulness as are birds. "Honesty is the best policy" was the outgrowth of a shrewd Yankeeism which evidently had tried both policies. "He treats me like a dog" was before the day that dogs received more attention than children and had more baths than tenement dwellers. "A stitch in time saves nine" was not only for rhyme, but was also written before the one-horse-shay type of clothing was purchasable as it is now under factory production. No stitch gives way now until the whole thing falls to pieces.

We have now the America of today: Cities ranging from six million inhabitants to towns of one hundred; ships from forty-six thousand tons to fishing smacks; power plants from five hundred thousand horse power to one-half a mouse power; buildings from forty stories to California bungalows; buildings forty stories up in the air to cabarets in sub-cellars where air is never present. We have clothes from machine-made to hand-made; Hamilton watches to Ingersolls; Rolls Royces to Fords; tractors to hand cultivators; pure bloods of Lawrences and Lowells to the bloods of Zrotskis, Chzerks and Einbrinz; religions from "hardshell" Baptists to Sunday night movies.

And just think of it! We are called upon to outline educational theory and practice at this period to be consistent with the art, religion, literature, politics, production, and all other civic, scientific, and social expressions of the day. And just think of it! We solemnly sit in solemn convention and solemnly attend solemn institutions to work out an educa-

tional theory consistent with a twentieth century life.

But before working out a theory of educational practice which is consistent with art, religion, industry, etc., of the period, we must ask, What is the art of today, the religion of today, the politics of today? Eight years ago we had Wilson; today we have Harding. Yesterday we had Newton and gravitation; today we have Einstein. Yesterday we had Booth and Barrett, now we have Charlie Chaplin. Only a minute before today Ford had 60,000 men doing a job and now he has 34,000 doing the same work. To repeat, we are called upon to outline educational theory and practice to be consistent with the social, economic, religious, and industrial life of today. Furthermore, we are called upon to fit the children of today into the children of tomorrow. We know nothing about the tomorrow. And tonight I feel that we know little about the today.

Man has always been educated for life. The slave was "educated" for slavery in Rome. The modeller of Winged Victory, the painter of the Sistine Madonna, the New England shoe cobbler, the watchmaker of Geneva, the Indian youth as he held tremblingly his first bow, the New England girl who walked with John Alden,—all were "educated" for their job.

All past attempts in education have been conscious attempts to fit the education with the social, economic life of the period. None of these attempts were forced ones; none could have been forced. From the earliest time, culture was one of the aims of the leisure class. Art, literature, and music were for them. Vocational life was for the large majority. Culture came thru language, music and art. Some of the higher grades of servants and slaves were the healers of their time. The sciences of astronomy and alchemy

were vocational expressions of the few. Their exponents were subsidized by the State. Philosophy was for the elect. Such were called before the courts and assemblies as we today call upon experts in theosophy, psycho-analysis, or psychiatry. The multitudes of that period went to their twelfth-century movies which were market places, and the upper "four hundred" to their cabarets which were then banquet halls.

Now we have a conscious feeling that culture is for all, that vocational training must be extended beyond the ministry, arts, music, and literature. Already we have recognized that law, medicine, nursing, teaching, and engineering are professions. Alchemy is now a science. Astronomy is now weather reports and sailing orders. Witchcraft is now psychology, psychiatry, and psycho-analysis. Palmistry is now vocational analysis. Theological dogmatism is now New Thought.

It is now recognized that science may be agricultural as well as test-tubish, that electricity has been moved forward from cat-fur sparks to alternating currents, that chemistry may deal with coal tar products to imitate strawberries, cherries, lemons, roses; that even nature may now produce a thornless cactus or a loganberry drink. Thru process of evolution, law, medicine, agriculture, engineering, teaching, dentistry, etc., have been elevated, standardized and labelled.

The higher used to think they should govern the lower—that they should think for them, make laws for them, and finance them. The higher are now being trained to work the lower, to design machines for them, to think out agricultural science for them, to doctor them, to judge them in court, to think for them in art, music, and literature.

The question occurs to me,—Shall the

lower be trained to work, not for the upper, but for themselves? Shall the mystery of medicine be made clear to the mass thru hygiene teaching? Shall the farmer who produces certified milk know what certification means other than thru Board-of-Health direction? Shall the prisoner before the bar comprehend justice, or merely accept the learned Latin phrases? Shall the worker make new justice or accept the old? Shall the worker have an appreciation of art, literature, music, without being a technician in one of these things? Shall the mass poet write free verse, or must we have traditional meter? Must the machinist have four years of collegiate training to get a machinist's degree? Must a longshoreman remain ignorant of

the laws of wages and prices? Is the street agitator to tell the gaping crowd that the rich are growing richer and the poor poorer and let it swallow such dribble, hook, line, and sinker. In brief, is there a culture for the lowly, and is there a vocational training which fits them to play their part upward as the upper crowd are being taught to play their part downward.

The vagrant and fellow out of a job on the bench next to me has curled up in his evening papers. The theater crowd has rolled by in taxis to homes or restaurants. Even the lovers in the shady spot over to my left have decided the hour is late. So have I.

—ARTHUR DEAN.

WASHINGTON CORRESPONDENCE

EDUCATION IN THE REORGANIZATION OF THE EXECUTIVE DEPARTMENT

NOT much has been said or done publicly during the past few weeks with reference to plans for education in the proposed reorganization of the government departments, but it appears that this subject has not entirely escaped attention. The Joint Congressional Commission on Reorganization has been holding frequent meetings, and is reported to have accomplished much in the way of preliminary investigation.

No authoritative statement has been made public, altho from time to time the papers have contained "correspondence" which is understood to indicate rather accurately the trend of official sentiment. One such statement appeared a few days ago, giving an analysis of certain points on which the Commission has reached agreement, and concerning which it expects to make recommendations to the Congress at an early date. Among these are:

(1) Consolidation of the War and Navy Departments into a single Department of National Defense.

(2) Retention of the Interior Department, to consist hereafter only of those services having to do with the public domain, and engineering and construction projects.

(3) Retention of the Department of Agriculture, with certain eliminations and modifications, to be regarded primarily as an agency for the development and conservation of natural resources.

(4) Organization of a Department of Welfare and Labor, education being included under Welfare.

Several other points of agreement were mentioned, but they are not of special interest here, and in every case, of course, it was explained that tentative agreement only has been reached. It was announced, further, that the Commission expected to make at least a preliminary report to Congress early in October, and that it was the intention to present a report with respect to the main features of which the President and the members of the Cabinet would be in agreement. To this end it was stated that the President would hold a number of conferences

during the latter part of September for the express purpose of reconciling certain differences of opinion which had developed. It was announced that the administration expects to have the proposals as finally agreed upon embodied in a bill to be introduced shortly after the opening of the next session of Congress, in December.

A DEPARTMENT OF PUBLIC WELFARE, EDUCATION, AND LABOR SUGGESTED

THE place of education in the reorganization has been one of the difficult problems to solve. Those who have been promoting the movement for a department of education have indicated an unwillingness to be satisfied with anything less, and a determination to persevere until their purpose is accomplished. The administration, on the other hand, has been represented a number of times, in a semi-official way, as having determined on a policy of economy in government expenditures, and as believing that the present is not an opportune time to establish a new department, and especially one providing substantial subsidies to the states. "One very good way to reduce government expenses and machinery is not to create new agencies," according to one spokesman for the administration.

Administration leaders were reported a few days ago to have reached a compromise agreement which they believe will be acceptable to the various interests concerned. In accordance with this plan

education would be one of the three principal and equally important divisions of a new department, the other two divisions being public welfare and labor. A number of important conferences have been held, and members of the Reorganization Commission are understood to believe that they can count upon the support of both houses for a measure drawn along these lines.

The division of education would not carry large appropriations to the state, but would include two special new features as proposed in the Towner-Sterling Bill, namely, a bureau of educational research, and a national educational council. Supporters of the plan point out that a strong national agency for education can be developed by this means, and they express confidence that this proposal will insure the co-operation of the educational groups in the consideration of the entire reorganization program.

THE DEPARTMENT-OF-EDUCATION PROGRAM

NEVERTHELESS, I understand that the program of those who are promoting the movement for a Department of Education remains unchanged. A conference of leaders has just been held here in Washington, at which an agreement is said to have been reached to proceed with the development of plans for the establishment of a Department, and to be prepared for action in Congress when the proper moment arrives.

—WILLIAM T. BAWDEN.

The aim of education for life is to send the child forth to do the work of the world, even the weary routine (no longer unintelligible drudgery, however) with eager zest, because the adventure of life is worth while.

HORACE B. ENGLISH.

Sept. *Atlantic*.

IN FOREIGN COUNTRIES

MANUAL TRAINING AND THE NEAR EAST RELIEF

MANUAL TRAINING is proving one of the greatest factors in rebuilding the lands ruined by the War. Especially is this true in Armenia where practically all industries and sources of production have been destroyed and

take the task, not only of their own support, but of rebuilding the economic life of the nation.

In all of the relief centers established by the Near East Relief, America's official agency for carrying on in Armenia and Asia Minor, classes in carpentry, shoemaking, tailoring and various other



WAR ORPHANS AT WORK IN CARPENTRY SHOP OF A NEAR EAST RELIEF ORPHANAGE
IN ERIVAN, ARMENIA.

where nearly all trained workmen have been killed in the massacres and fighting. The boys and girls who are gathered in the Near East Relief orphanages, and the few adults who are able to obtain work at the American industrial centers, are practically the only artisans in the country. The one hope of the future is that the boys and girls rescued by the Near East Relief shall be trained in manual arts and trades so that at the earliest possible moment they shall under-

trades have been established. The progress made is remarkable. So many hours each day are devoted to this work. Every institution boasts several experts along each line who are perfectly equipped to support themselves and who only await the age of discretion (fifteen or thereabouts) before they are turned out to shift for themselves.

In the Alexandropol orphanage, for instance, where are concentrated more than eighteen thousand orphans, the

largest collection in the history of the world, all of the furniture, all of the dishes, and much of the clothing worn by the inmates, are made by the boys and girls. Moreover all of the less technical of the repair and construction work in connection with the laying of walks, putting in of windows, building of doors, and mending of roofs and walls is done by the orphans.

In an orphanage in Jerusalem such was the skill of the youthful workers that the English governor of the province gave them an order for the furnishing of his home. Three thousand dollars worth of furniture was built by the teachers and the older boys. It was of the most original and unique design. Heavy stone and marble were combined with richly carved woods in the making of the dining room set. Every bit of the work was done by hand, and the governor, who is artistic as well as luxurious in his tastes, declared it of the most exquisite workmanship.

Next to the actual feeding and life-saving work, this training in manual trades and arts is the greatest service that American charity can render the stricken peoples of the Near East. It is making the boys and girls self-supporting and at the same time putting the American charity on the most economical and efficient basis possible—making the children pay their own way. What this training will mean to the boys and girls, once peace is restored and they are able to build up their economic life, is incalculable.

At present there is danger of the necessity for curtailing this manual training work, due to the increased number of children left homeless by the fighting

thruout Asia Minor and the need for funds and workers to save them. Every other interest is having to be put second to this most urgent call for food and shelter. However, if American charity



LANTERN MADE BY ORPHANAGE CHILDREN
IN CONSTANTINOPLE FROM BITS OF
OLD TIN AND WOOD.

is to do a really constructive and lasting piece of work, as well as build up a sound economic foundation which shall soon remove the need for further calls upon it, this industrial training should not be abandoned.

—MARY LENA WILSON.

Without tools man is nothing; with tools he is all.

—CARLYLE.

PROJECTS, PROBLEMS AND NOTES

TOYS AND BOYS

ADDRESSED TO MR. DO NOT KNOCK

WHEN the baby was two years old and picked up a piece of paper and played house with it do you not recall how glad you were? When your boy was four years old and you came home (you, father, I am talking to) and you found that he had taken an odd piece of wood and some spools and made a cart, do you not recall how delighted you were? You sat down and could see his future thru all the stages to a Thomas Edison or Henry Ford.

Later when you helped him take a piece of wood three feet long and some old wheels and gave him the price of a battery and electric bulb, and you two built a junk auto, do you not recall how the neighbors all gathered around to look? Everyone turned on the street to see the thing go by, with its last year's license plate on and its baby carriage wheels and its corrugated iron radiator, etc. Well! that is manual training.

When your boy comes home from school with an auto about twelve inches long with a slightly lop-sided wheel and the paint spattered on, do not knock. He may have been studying about the use of autos in transportation. When

your boy brings home a tin can engine and you put on your critical glasses, take them off immediately and put on your introspection glasses and reflect.

If manual training to you is simply making a perfect thirty-six, you are wrong; but, in turn, if it is making a poor thirty-five and knowing how it is made, you are right.

—STANLEY MILLER,
Hackensack, N. J.

SOLDIER

THIS is one of the famous French toys that have come to America since the war. It is given in detail not only because some boys may be glad to reproduce it, but also as a suggestion for other similar toys which may be designed by students. (a) Notice first how the use of different thicknesses of wood and the setting of thin pieces inside of thick ones, as in the case of the legs, the ground, and the head, have added to the fine effects desired. (b) Notice also the excellence of the contour and proportions of the whole and of each part. (c) See how the shadows are used to make the figure more real. (d) Unfortunately, neither the photograph nor the drawings show the colors, but these have been studied with as much care as the con-

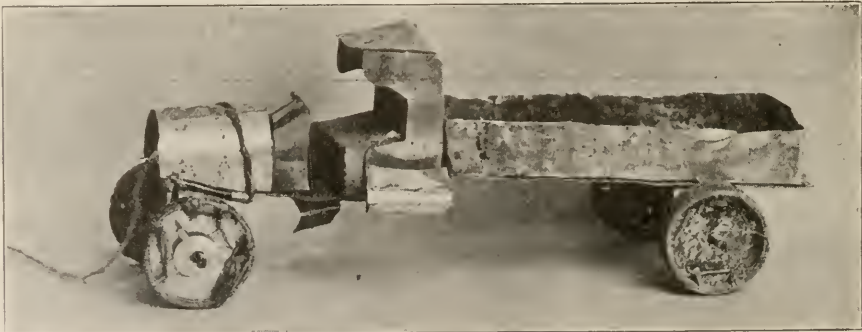

TOY AUTOMOBILE TRUCK MADE BY CHILDREN IN NEAR EAST RELIEF ORPHANAGE
IN CONSTANTINOPLE.



THREE POSES OF THE SOLDIER.

tours and the shadows. The coat is a light grey-blue; the shadows on the coat are a darker tone of the same color; the boots are dull tan of the same intensity as the color of the coat; the shadows on the boots are brown; the ground is dull

green; the hands and face are flesh color; the shadows on the hands are dull red, on the face they are brown; the two horizontal streaks across the cap are dull red, and there are red spots to represent shoulder straps and decorations on the

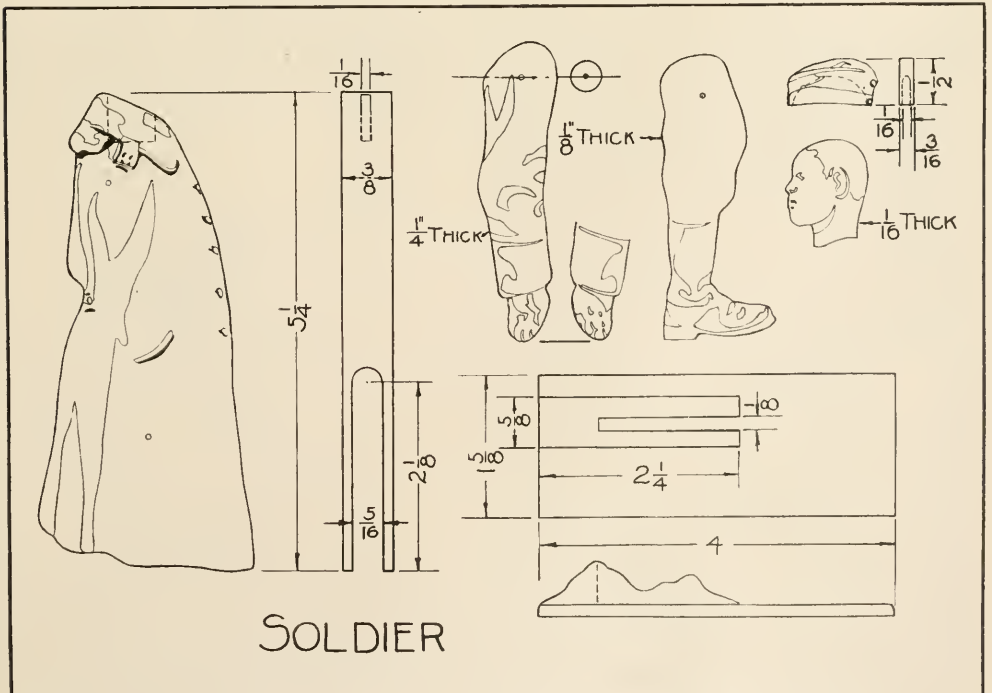

SOLDIER PARTS- FULL SIZE



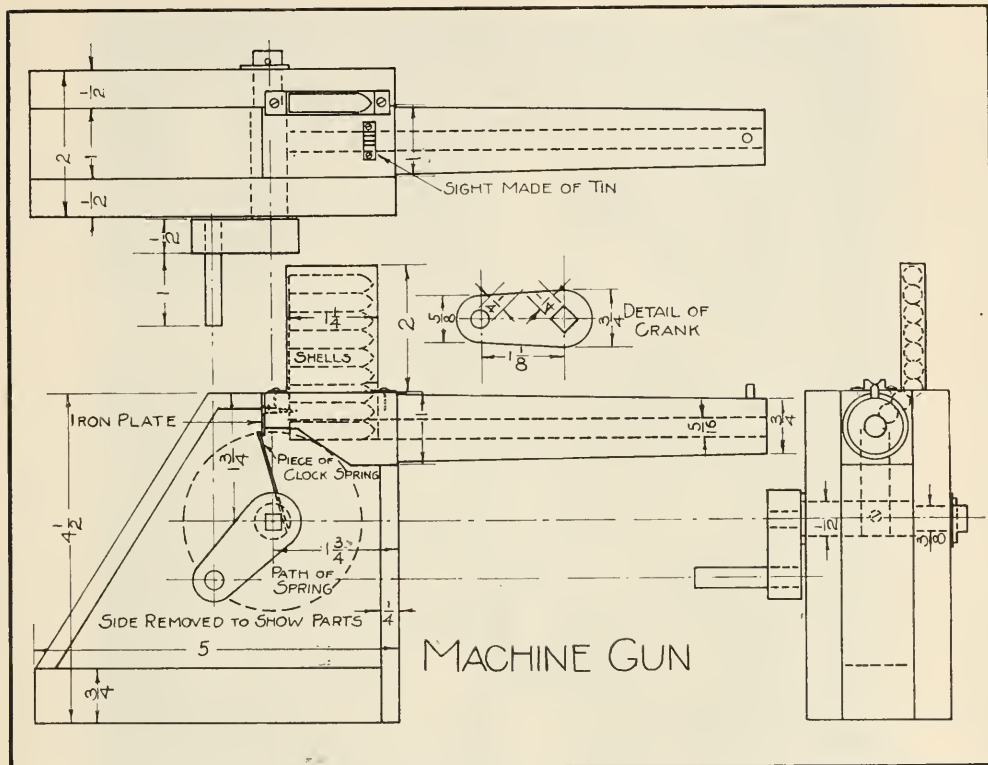

collar; the buttons are touched with the flesh color; the hair is the tan used on the boots; the whole is a very harmonious and pleasing color scheme.

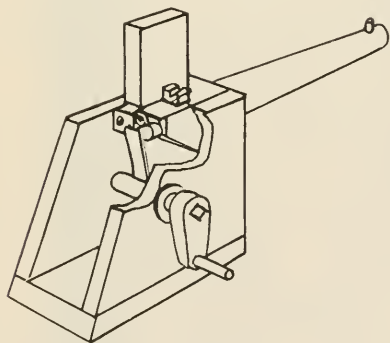

MACHINE GUN

THE little sketch and the working drawing of the machine gun tell just enough to guide an ingenious boy in making a very successful toy. The drawing does not tell him everything he may want to know but it does show him the possibilities

and gives him the forms and main dimensions. It will be noticed that most of the parts may be made of wood, but the magazine for holding the "shells" should be made of tin, bent and soldered into a box open at both ends. At the lower end lugs are provided by which the magazine may be attached to the barrel. It is clear that the vital thing in the construction is to provide a good, stiff spring.

TOYS MADE FOR SALE AT ROCHESTER

THE following is quoted from a letter received last December from Raymond C. Kepple, at that time director of manual training, Rochester, N. Y.:

"Considerable interest has been shown by some of our teachers recently in toy-making as evidenced by the enclosed photograph of an exhibit of toys at No. 11 school. Something like two hundred toys were made by the boys in manual training under the direction of Miss Ethel H. Severence, manual training instructor. These toys were painted and decorated by the boys and on December 10th, a sale was held and the entire output disposed of at approximately \$125.00. The proceeds, over and above the cost of supplies, is to be used to purchase some article for the school.



EXHIBIT OF TOYS MADE BY MANUAL TRAINING BOYS IN SCHOOL No. 11, ROCHESTER, N. Y. MISS ETHEL H. SEVERENCE, INSTRUCTOR.

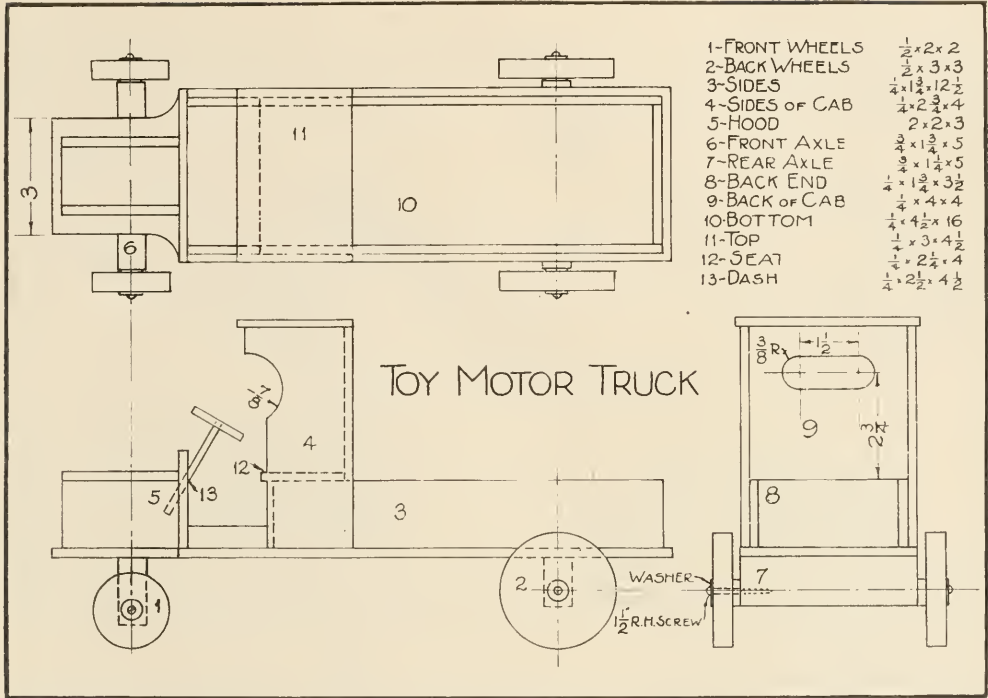

The exhibit created quite a bit of enthusiasm among other instructors, and, as a result, I think toy-making may increase."

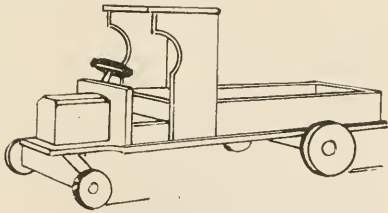

TOY MOTOR TRUCK

THIS design was taken from one published two years ago in the English magazine, *The Woodworker and Art Craftsman*. It seems to meet the conditions of a good toy and of construction in a school shop.

TOY MAKING IN PITTSBURGH

My dear Mr. Bennett:

Under separate cover, there is being sent to you a drawing of some of the toys that were made in the Pittsburgh Public Schools during the Christmas season. The wheel horse and the duck rocker were made Christmas, 1919, and the dolls' cradle and the toy auto were made in the season of 1920, along with the aeroplane and such other toys as the instructors in the schools cared to make.

The toy proposition was taken up for the purpose

of furnishing the children in the Kindergarten with Christmas toys. You can see what a splendid co-operative piece of work this could be made.

The woodwork on the horses and on the duck rockers was done by the boys in the 6th, 7th and 8th grades while the coloring was done under the direction of the art supervisors in the various schools. The writer happened to be visiting one of the elementary schools while the coloring was being applied to some of these toys. The orderly manner in which the problem was handled, the attention and the interest of the children was far more than commendable. The co-operation of the director of art, who at that time was C. V. Kirby, was not limited to any one particular school but covered the entire district.

The toy work gave all of the teachers an opportunity to show how they could organize their schools for turning out productive work.

You will notice that this drawing was made by Edward C. Fitzgerald, manual training instructor at the Rose School. Mr. Fitzgerald, in making the aeroplane, conventionalized the rose so as to develop a little more interest in applying the design on account of the name of the school.

It is needless to say that the problems worked out were greatly appreciated by all the children.

—JOSEPH M. SPEER.

Supervisor of Industrial Education.

DOLL CRADLE

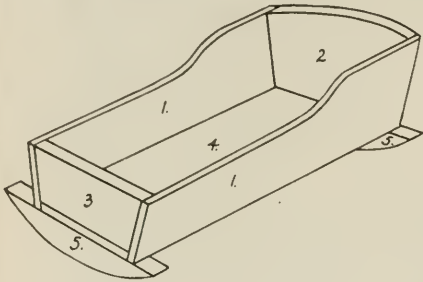

No	BILL OF MATERIALS	Need
1	SIDE $\frac{1}{8}$ X $3\frac{1}{4}$ X 10	2
2	HEAD $\frac{3}{8}$ X $3\frac{1}{2}$ X $5\frac{1}{2}$	1
3	FOOT $\frac{3}{8}$ X 2 X $4\frac{3}{4}$	1
4	BOTTOM $\frac{1}{8}$ X 7 X $10\frac{3}{4}$	1
5	ROCKER $\frac{3}{4}$ X $1\frac{1}{2}$ X $5\frac{1}{2}$	2

Toy Auto

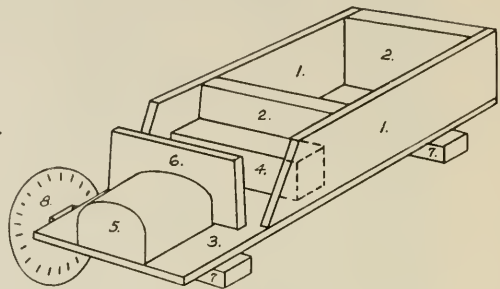

No	BILL OF MATERIALS	Need
1	SIDE $\frac{1}{8}$ X 2 X $7\frac{1}{4}$	2
2	BACK & FRONT $\frac{3}{8}$ X 2 X $3\frac{1}{2}$	2
3	BOTTOM $\frac{1}{8}$ X $3\frac{1}{4}$ X 10	1
4	SEAT $\frac{3}{4}$ X $\frac{3}{4}$ X $3\frac{1}{2}$	1
5	HOOD $\frac{1}{2}$ X 2 X $2\frac{1}{2}$	1
6	DASH $\frac{1}{8}$ X 2 X $3\frac{1}{2}$	1
7	AXLE $\frac{1}{2}$ X $\frac{3}{4}$ X $4\frac{1}{2}$	2
8	WHEELS (2 TIN ROOFING CUPS)	2

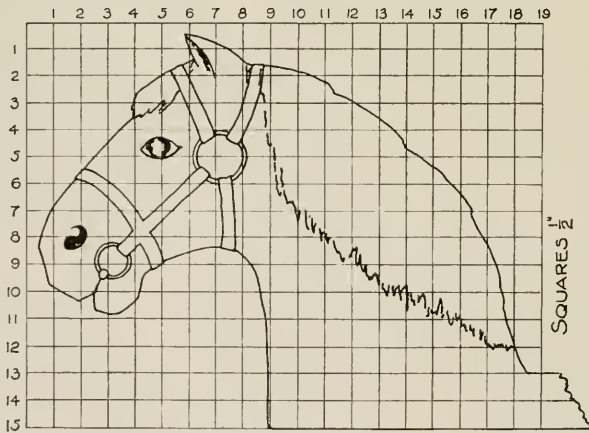

WHEEL HORSE

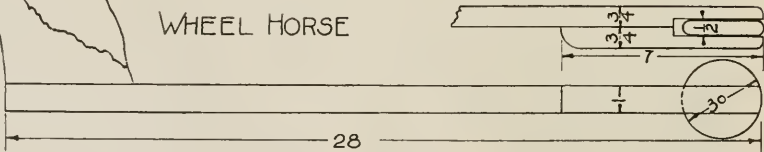

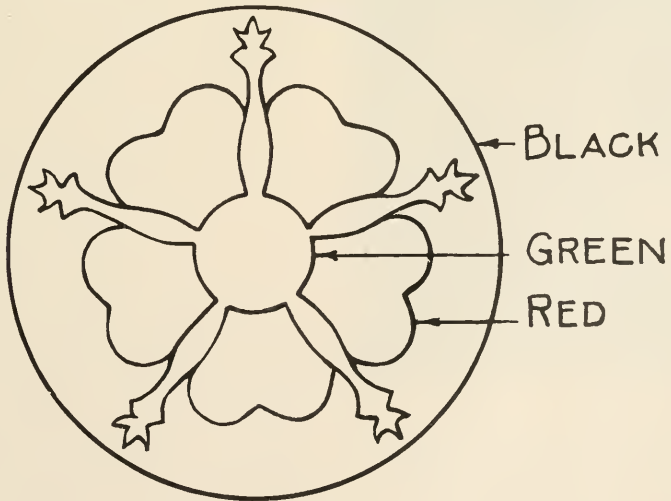
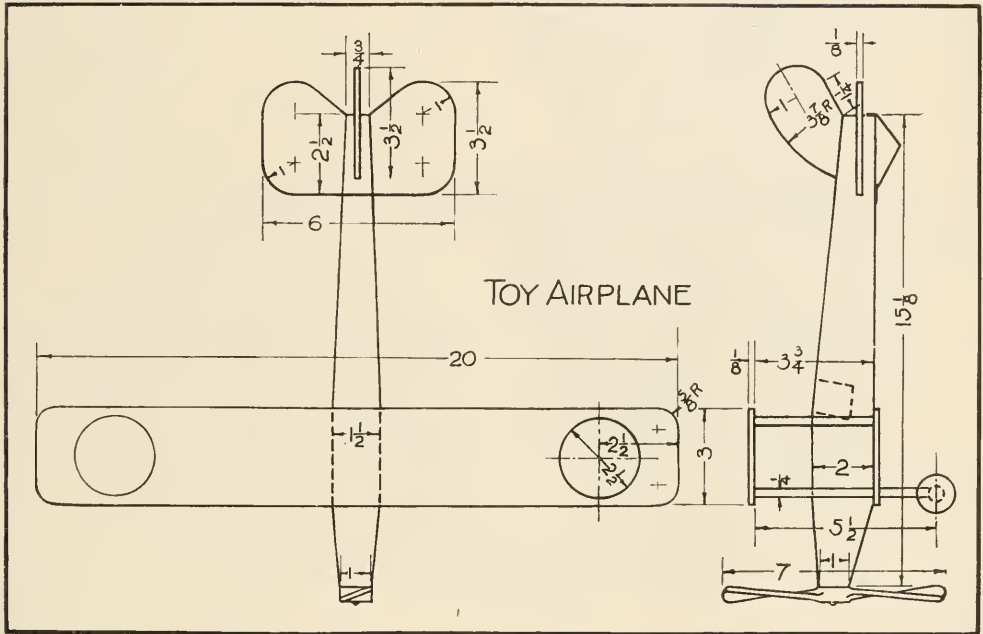

FULL-SIZE DETAIL OF DESIGN TO GO IN CIRCLES ON THE WINGS.

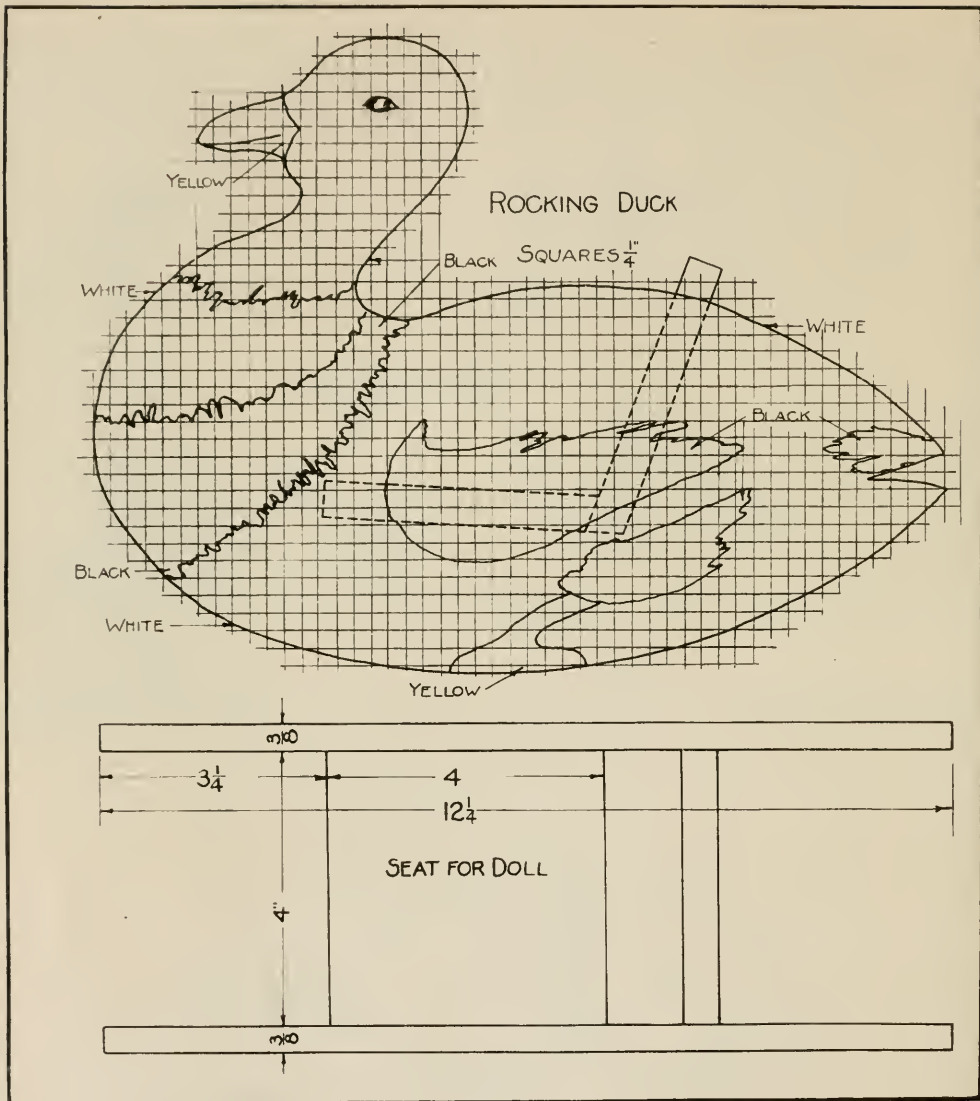

WINDMILL

THE accompanying photograph of a windmill was received from Stanley Mythaler of the manual training department of the State Normal School at Valley City, N. D. The drawing showing the details is the kind Mr. Mythaler has used in his own school shop. He says of the toy,

"Because of its ability to go or do work it has proved popular in the grades. The vanes should be nailed in the hob and a washer placed between hub and bearing. A sleeve of tin or wood on the wire shaft between the bearing and crank will keep the wheel in position."

THE WALKING WALLAPUS

IN THE December, 1919, number of this Magazine there appeared what was termed a "walking wallapus." This was submitted by E. F. Juergens of Middletown, Ohio. The form and action of this toy was so amusing that it attracted immediate attention and its popularity has increased since that time. We understand that it has been patented and placed on the market for the present season's trade by a large toy-manufacturing company.

A few months ago we received from Joseph H. Wilson of Washington, D. C., the following verses

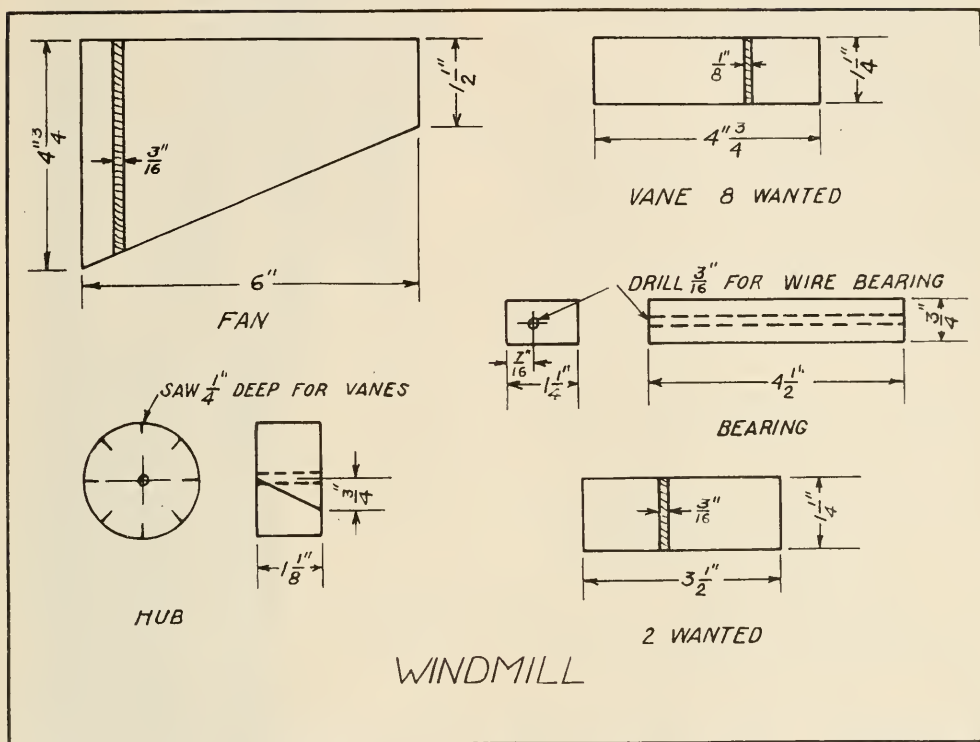

which will be interesting to all of our readers who have seen the "wallapus" in action.

Have you seen the Walking Wallapus,

That creature strange and queer,
Who's not a bird, nor fish nor beast
Nor reptile children fear?

His breast is like a camel's hump,
His neck just like a whale;
He's striped like some fierce tiger
With an alligator's tail.

His legs are like an elephant's;
His feet have funny toes;
He wears a smile upon his face
And has a queer flat nose.

His head is like a cockatoo's
That comes up in a peak:

His mouth is just a cross between
A fish jaw and a beak.

He's short and long and narrow
And has no wings to fly,
But like a white-faced monkey,
He has a tricky eye.

Sometimes he sits upon his tail,
His head held in the air,
But when he rests upon his breast
His tail is up for fair.

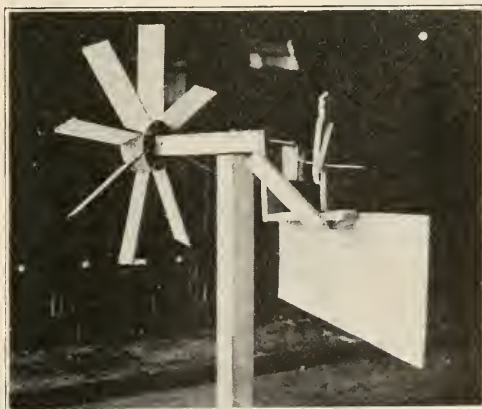

But put him on the Wally Board
And soon that lazy chump
Wakes up and does a funny thing:
Ker-plump, ker-plump, ker-plump.
He starts to wobble up and down;
He walks and slips and slides,
Which makes good children laugh until
They nearly split their sides.

CURRENT PUBLICATIONS

Lettering. A Handbook for Artists, Architects, Signwriters, and Craftmen. By Arthur E. Payne, London. Published B. T. Batsford Ltd. 94. High Holborn, London, England.

The author of this small volume has confined himself to examples of a few of the most useful historic alphabets which are needed by craftsmen of various types, such as sign writers, stone cutters, engravers, and designers generally. The selection is the outgrowth of fifteen years of experience by the author as a teacher.

He has found that the need of the craftsman is the intimate working knowledge of some of the most common types of lettering and has presented the examples of these with directions for their reproduction.

Mathematics for Electrical Students. By H. M. Keal, head of Department of Mathematics, and C. J. Leonard, instructor in mathematics, Cass Technical High School, Detroit, Michigan. Published by John Wiley and Sons, New York, 1921. 4 $\frac{3}{4}$ x 7 in.; 230 pages; illustrated; price \$1.60.

This is a book written for the definite purpose of helping the students of electricity who have not completed high school to solve the mathematical problems in their shop work. All parts of algebra, geometry, and trigonometry which apply to the work have been discussed carefully, while those that simply have to do with entrance requirements for college have been avoided as being outside the scope of the book.

It is suggested by the authors that the book does not claim to be a text book for electrical shop work, but a mathematics book written for electrical students and workers. As such, the book appears to be such that it will substantiate the claims that are made for it.

Mathematics for Shop and Drawing Students. By H. M. Keal, and C. J. Leonard, Instructors in Cass Technical High School, Detroit, Michigan. Published by John Wiley and Sons, New York, 1921. Size 4 $\frac{3}{4}$ x 7 in.; 214 pages; illustrated; price, \$1.60.

This book is another of the Cass Technical High School series of vocational and mathematics texts. It is a companion book to the one for electrical students previously mentioned, and is written for general shop and drawing students in the same concrete way of approach and with the same clearness of purpose which are characteristics of the latter. The method of presenting the subject-matter is direct and definite. Applications are made to practical conditions in shop and drawing room so that the student may work his way thru the subject with a minimum amount of attention from the teacher. This makes the book of particular value for use in part time and evening school work.

RECEIVED

Administration of Child Labor Laws. By Ethel E. Hanks. Industrial Series No. 2, Part 4. Bureau Publication No. 85. A bulletin discussing the employment certificate system of Wisconsin. Published by the Children's Bureau, U. S. Department of Labor, Washington, D. C.

Vocational Teachers Review. A bulletin covering the vocational work and other activities of the summer session of the State Normal and Training School, Oswego, New York. Published and printed by the students of the summer session 1921.

Selected Reading List for Administrators and Teachers in Part-Time Schools. By Emily G. Palmer. Part-Time Education Series. Leaflet No. 3. A comprehensive list of reference material concerning part-time schools. Issued by the University of California in co-operation with The State Board for Vocational Education.

Floors and Floor Coverings—Farmers' Bulletin 1219. A treatment of different material for floors, the construction of floors, staining and polishing. Discusses in detail different kinds of floor coverings—rugs, carpets, linoleums, etc., their care, mending, and storing. Issued by the U. S. Department of Agriculture, Washington, D. C.

State Laws Relating to Education. Bulletin, 1920, No. 30. Department of the Interior, Bureau of Education. Compiled by William R. Hood. A bulletin covering such state laws related to education as were passed during 1918 and 1919.

Suggestions for a Program for Health Teaching in Elementary Schools. Health Education No. 10. Bureau of Education. By J. Mace Andress and Mabel C. Bragg. A bulletin containing many valuable health rules and other suggestions for the teachers of elementary schools.

Games and Play for School Morale. By Mel Sheppard and Anna Vaugan. Published by Community Service. One, Madison Avenue, New York City. Price 25 cents. This is a booklet containing a course of graded games for school and community recreation which should be welcomed by all who are concerned with the proper use of the play hour. It contains games arranged for all ages from the first grade pupil including a series of play activities for adults.

First Course in Analytical Geometry. Second Edition, Enlarged. By Charles N. Schmall, Instructor in Mathematics. Public Schools of New York. Published by D. Van Nostrand Co., New York, 1921. Size 5 x 7 $\frac{3}{4}$ in.; 338 pages; illustrated; price \$2.25.

Bulletin of the American School. A monthly publication by the American School. Dresdel Avenue and 58th Street, Chicago.

You save drill points with a "Yankee" No. 44

This *Automatic Push Drill* is the only drill with adjustable tension. To drill, push on the handle. The handle springs back automatically for the next stroke.

To regulate the pressure to suit size of drill-point used and the work in hand, turn the cap on the end of the handle. This increases or diminishes the tension of the spring in the handle. A "Yankee" No. 44 saves breakage on drill points. It enables you to work faster, better and with less exertion.

The "Yankee" No. 44 has seven different tensions and is equipped with eight "Yankee" drill points, $\frac{1}{16}$ to $\frac{1}{64}$ in., held in a magazine that opens up, toward chuck, for convenience.

The "Yankee" No. 41 is another Automatic Push Drill—without the tension adjustment, for those not requiring this feature.

Some other "Yankee" Tools

Spiral Screw-drivers	Ratchet Breast Drills
Ratchet Screw-drivers	Ratchet Bench Drills
Quick Return Spiral Screw-drivers	Ratchet Chain Drills
Plain Screw-drivers $1\frac{1}{2}$ to 30 in. blades	Ratchet Tap Wrenches
	Bench Vises, Removable Base

Dealers everywhere sell "Yankee" Tools

You should have this book Mailed FREE

Contains numerous illustrations of interest to all who want to know the easiest way of doing quick and accurate work. Pictures "Yankee" Tools and explains their mechanical features. Write Today for it.

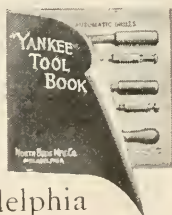

NORTH BROS. MFG. CO., Philadelphia

"YANKEE" TOOLS

Make Better Mechanics

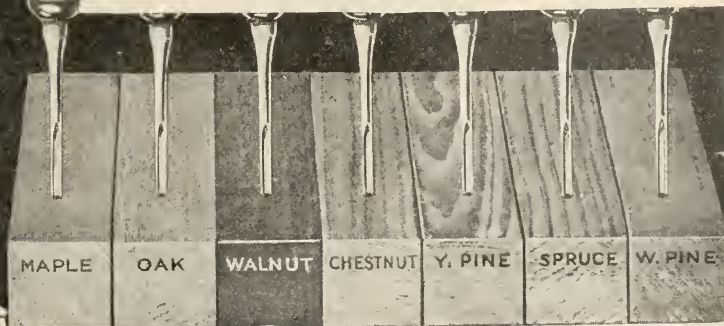

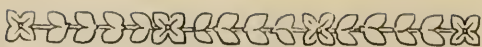

FIELD NOTES—(Continued)

teachers who were taking advantage of the summer session to acquire more expert knowledge and more mechanical skill for their work during the coming year.

The growth of this department has been extremely rapid under the guidance of Geo. W. Davis, who has been professor of industrial education at this institution for the past three years. Professor Davis loses no opportunity in making his department serviceable to the teachers of the state.

The classes in vocational guidance were conducted by Frank M. Leavitt; associate superintendent of Pittsburgh public schools.

ANOTHER EVIDENCE of the growing demand for vocational education is the report from the Boys' Vocational School, Newark, New Jersey, that the school was filled to capacity within one hour after the office opened for enrollment, and that 150 boys have been refused an entrance on account of lack of room and equipment. Harold F. Fuller is principal of this school which has made itself so attractive to the boys of Newark and vicinity.

THE BOYS' VOCATIONAL SCHOOL at Terre Haute, Indiana is enjoying a greatly increased enrollment this fall. Last year the number of students was 150. This year it is expected to reach not less than 225. Before the opening date of the school 53 new students had applied for the various courses offered.

During the summer, the school, which is under the able direction of Hubert Fisher, has enlarged its facilities for taking care of the additional students which were expected for the fall. The auto-mechanics department, particularly, which was found unable to meet the demand made upon it last year, has received special attention, the garage having been overhauled and new equipment added. A course of physics, in charge of Otto L. Wood, is a new addition to the curriculum this year.

FORTY-EIGHT ADDITIONAL MACHINES which have been purchased from the government will be installed into the school shops of Chicopee, Mass., under the supervision of John H. Sullivan, director of manual training. They will increase greatly the opportunities for the boys who are taking shop work. Both day and night classes are conducted.



GOOD TOOLS ARE ESSENTIAL FOR GOOD WORK

Since 1848 we have adhered to one policy—to handle only the very best in quality.

Our 300 page catalog illustrated above is of particular value to those interested in manual or vocational training. If you haven't a copy ask for Catalog No. 224.

HAMMACHER SCHLEMMER & CO.

Hardware, Tools and Supplies

New York, Since 1848, 4th Ave. and 13th St.

TOOLS

For Manual Training Shops.
Send your inquiries to and get the especially low prices quoted by

MONTGOMERY & CO. Inc.,
105 Fulton Street New York City



WE ARE GENERAL AGENTS FOR THE WORLD
FAMOUS GENUINE RICHTER

DRAWING INSTRUMENTS

They represent the highest standard in quality
and have no equal anywhere.

Write and give requirements.

*Complete circular showing sets and separate tools
mailed on request.*

U. S. BLUE PRINT PAPER CO.
CHICAGO, ILLINOIS



VENUS PENCILS

*The largest selling Quality
pencil in the world*

For high lights and deep
shadows, for quick or
detail sketching, for
smoothness and ac-
curacy, the famous
VENUS pencils are
unexcelled.

17 black degrees, 3 copying

For bold heavy lines

6B-5B-4B-3B

For general writing
and sketching

2B-B-HB-F-H

For clean fine lines

2H-3H-4H-5H-

6H

For delicate thin lines

7H-8H-9H

Plain Ends, per doz., \$1.00

Rubber Ends, per doz., 1.20

*At Stationers and Stores
throughout the world.*

American Lead Pencil Co.

219 Fifth Ave. (Dept. A.) N.Y.

also London, England

The Student Needs Printing

as much as he needs the alphabet

Q It is as much a part of Education
as English, the Rule of Three and
History. It is, in fact, a combination of
all studies—a practical illustration of all
the student learns from teachers and
books. It is at once a science, an art and
an occupation. It gives him manual,
mental and moral training. It helps him
form habits of industry, accuracy and
taste. It is a joy to the learner and a
splendid asset in every relation of life.

Q We supply printing outfits for schools,
and give the benefit of our experience
and that of schools which have tried out
the plan. No school is complete and
doing its best work, or near its best work,
unless printing is a part of its equipment.

Q Send to us for help in your problem.



Barnhart Brothers & Spindler

Type Founders

Chicago Washington, D.C. Dallas Saint Louis
Kansas City Omaha Saint Paul Seattle

MAYDOLE HAMMERS

THE WORLD'S STANDARD

Highest Quality Steel Handled Hammers
Guaranteed First-Class in Every Respect

*Booklet of Useful Information
for each student on request.*

The David Maydole Hammer Co.

Norwich, N. Y., U. S. A.





A RARE old violin is more than a subject of *pride*—it is treasured for its superlative *tone quality*.

There's reason also for the pride which people take in their ownership of a set of Stanley Tools.

Stanley Tools do better work, and do it more easily. They have a splendid appearance, yet counting the length of service, they cost less than *cheap* tools.

Ask your dealer or write us for a copy of Stanley Tool Catalogue No. 34. It will help you in your selection of a first class tool kit.

THE STANLEY RULE & LEVEL PLANT.
THE STANLEY WORKS
NEW BRITAIN, CONN. U.S.A.



FIELD NOTES—(Continued)

CERTIFYING OFFICER NAMED

RAYMOND C. KEOPLE, who has held the position of director of manual training in Rochester, New York, has been appointed local employment certification officer. This office which is created thru an amendment to the labor and compulsory education law, will be charged with the granting of employment certificates, in addition to numerous other duties.

Mr. Keople was graduated from University of Rochester in 1905. He was employed by the Western Electric Company for a number of years, after which he returned to the University of Rochester for post-graduate work, receiving his master degree in 1912. He was appointed director of manual training in Rochester in 1918 and has held this position until he was promoted to his present office.

INDUSTRIAL SCHOOL FOR MOUNTAINEERS

Near Shull's Mill on Boone Fork in the mountain district of North Carolina, made famous by Daniel Boone, a unique school—the Boone Fork Institute—has been established for the purpose of giving industrial training to the youths of the surrounding mountain region.

An old mill has been converted into a school building. Machinery, particularly for woodwork has been installed in one end, while the other has been arranged into recitation rooms.

This part of the state is largely devoted to the lumber industry, the Boone Fork Lumber Com-

Building Phonographs is Ideal Shopwork



It is easy, by our methods, and yet requires precision and delicacy of workmanship to achieve best results. The boys will enter the work with new enthusiasm. At home the machine is a source of real, lasting pleasure. We supply blue prints, tone-arms, motors, case material and all accessories at lowest prices. Materials the very

best, fully guaranteed. Our machines play any make record. Write today for full particulars about our co-operative plan for manual training teachers. We plan the work for you.

Federal Supply Company
 410 West 28th Street Indianapolis, Ind.

No More Loose Handles

Don't take chances with Hammers with ordinary Wedges when you can now secure the **UNCLE SAM BRAND** Hammers with the new **VAUGHAN'S EXPANSION WEDGE**.

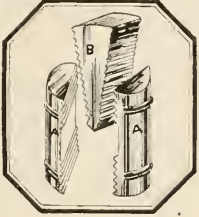

If the handle shows any tendency to become loose simply set the Wedge (B) a notch or two deeper between the pins (A) and a tight handle is assured.

UNCLE SAM HAMMERS are the only Hammers that have been approved by the **UNDERWRITERS' LABORATORIES** and each Hammer has the Underwriters' Label. It took 900 lbs. more pressure to pull the handle through the head with the **VAUGHAN'S EXPANSION WEDGE** than with the Ordinary Wedge. Uncle Sam Hammers are made in all patterns and sizes. Write for description booklet No. 10 which describes this line in detail.

VAUGHAN & BUSHNELL MFG. CO.

2114
Carroll
Ave.



Chicago,
U. S. A.

SAW TABLES

For MANUAL TRAINING

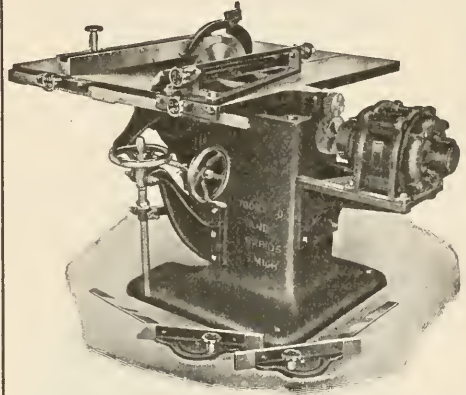

This cut shows our motor driven spiral gear saw table. No countershaft, no belts. Tilting or stationary tops. Write for circular and prices on our entire line. Address

ALEXANDER DODDS CO.
451-453 Monroe Ave., N.W.
GRAND RAPIDS, MICHIGAN, U. S. A.

Toy Patterns

By MICHAEL C. DANK

Instructor of Manual Training, Brooklyn, New York

TOY-MAKING is a most fascinating manual training activity with these "Toy Patterns." The work can be carried on in the home or schoolroom with children from six to twelve years of age. This publication consists of a collection of sheets of full-size drawings of toys interesting to the child and full of the play spirit. Among the toys are Animals, Animal Rocking Toys, Wheeled Platform Toys, String Toys, Lever Toys, Freak Toys and Novelties. They are designed to be made with the coping saw out of thin wood. In all, there are twelve sheets, size 10½" x 14", enclosed in a portfolio with an attractive color design.

Postpaid, 80 cents

Ask for a copy of our new
Descriptive Catalog

THE MANUAL ARTS PRESS
Peoria, Illinois

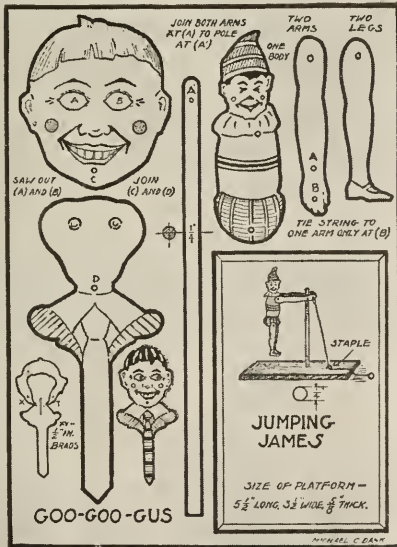

Copyright, 1921, Michael C. Dank. Published by the Manual Arts Press, Peoria, Ill.

PUPILS SHOP ACCOUNTS

do Not Trouble Instructors Using Our Systems. Pupils do all the Recording Accurately and "to date." All Accounts are Kept

AUTOMATICALLY

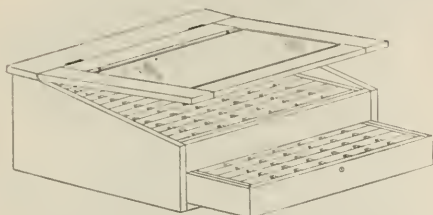

One of our Many Designs of the Industrial Arts Record. Built to Handle Any Number of Pupils.

Priced \$15 to \$85 with Liberal Discount in Quantities.

Let your problem be our burden

MANUAL ARTS SPECIALTY CO.

"Makers of Shop Efficiency"
ATCHISON, KANSAS

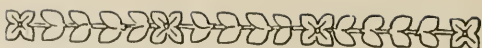

FIELD NOTES—(Continued)

pany, which is located at Shull's Mill, being one of the largest of its kind in the Appalachains. This lumber company has done much to make the establishment of this school possible.

DUBUQUE, IOWA, has offered to organize classes in industrial subjects not now given, such as auto-mechanics and electricity, to boys who are out of work and who are not subject to the compulsory education law, if they will make application for such work and return to school.

ART CONFERENCES ANNOUNCED

The schedule for the tenth annual conferences on art and industrial art for the state of New York has been announced. There are thirteen different meeting places with no conflict of dates. Every teacher or supervisor of art or industrial art is expected to attend one of the meetings.

One of the major purposes of the conferences will be to study the report of the committee on art education of the Educational Congress of May 1919. Exhibits of work done in the schools will be shown at each meeting. The conferences are called by the division of vocational and extension education of the University of New York and are under

WORK SHOP NOTE-BOOK

WOOD WORKING

Arranged by **GEORGE G. GREENE**
Instructor Lane Technical High School, Chicago

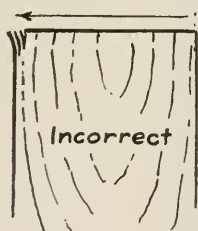
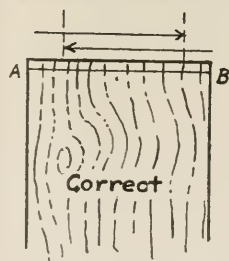

A small-size, boiled-down textbook and note-book combined. It is a note-book which saves the time of both teacher and pupil; a practical help to the pupil to remember "what the teacher did and what the teacher said." It furnishes a few general and extremely important di-

rections about tools and processes. It provides space for additional notes and space for working drawings of exercises and articles the pupil is to construct.

In a brief, concise, simple way it tells about

Shop Conduct	The Gage	Wood	Glue	Finishing
The Rule	The Saw	The Plane	Nails	Helps in Laying
The Try-Square	The Chisel	Boring Tools	Screws	Out Work

It is essentially a collection of helps, ideas, hints, suggestions, questions, facts, illustrations, etc., which have been prepared by a practical teacher to meet a real need in his own shop—a need which is identical in woodworking shops everywhere.

Price, postpaid, **28 cents.** Discount in quantities.

THE MANUAL ARTS PRESS, PEORIA, ILLINOIS

FIELD NOTES—(Continued)

the direction of Leon L. Winslow, specialist in drawing and industrial training.

TRADE AND INDUSTRIAL TEAMS
GIVE DEMONSTRATION

The following is taken from the "Montana Vocational News Letter":

"A number of high schools giving vocational education sent demonstration teams to the State Fair this year as a part of the Trade and Industrial Exhibit. Fergus County High School set up an "X-Ray" automobile chassis in which all working parts were exposed and so illuminated it that its operation could be closely observed. A team of boys instructed interested groups of people in automobile and gas engine operation giving advice and answering many questions that were asked. Teams from Custer County High School and Harlow High School showed their skill in demonstrating repair work on various parts of the automobile."

FROM HAWAII

For the coming bienium, the Territory of Hawaii has appropriated the following amounts to be spent for industrial training purposes; Island of Kauai, \$10,000, Island of Oahu, including Honolulu, \$20,000, Island of Maui, \$10,000, Island of Hawaii, \$15,000.

COURSES IN SILK KNITTING OFFERED

Northampton, Massachusetts is given opportunities to the students to learn silk knitting while in school. Much intricate machinery has been installed for this purpose. As far as is known this is the second city in America to provide for this type of school training, Milwaukee being the first one to make such provision.

**Build Your Own
PHONOGRAPH**

Instructive—arouses pupils enthusiasm—provides one of the best problems in cabinet making.

Let Your Pupils Build Choraleon Phonographs

We furnish plans, blue prints, motors, tone arms, case material—in fact, everything required. Full instructions. Choraleon's have fine tone. Play any record. Ask for particulars.



CHORALEON PHONOGRAPH CO.
1121 7th St., Elkhart Ind.

**EQUIP YOUR COURSES WITH MODERN
SHEET METAL WORKING MACHINES**

BE sure to have the Niagara Catalogs on hand when ordering new sheet metal working machinery. Catalogs give sizes, weights and capacities.

Write for complete catalog of Presses, Foot and Power Shears, or Tinners' Tools and Machines.

Niagara Machine and Tool Works
BUFFALO, N. Y., U. S. A.

NIAGARA

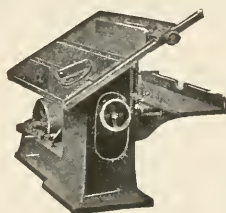

**Crescent
Wood
Working
Machines**

are the tools your students will eventually use so give them the opportunity now of learning about this splendid line of wood working machinery.

Send today for our catalog of band saws, jointers, saw table, shapers, variety wood workers, planers, planers and matchers, cut off saws, disk grinders, borers, hollow chisel mortisers, Universal wood workers.

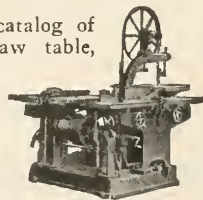

The Crescent Machine Co.

46 CHERRY ST.

LEETONIA, OHIO

**"JORGENSEN"
HAND SCREWS**

Withstand the abuse of inexperienced hands.

Steel Spindles
Steel Nuts
Hard Maple Jaws

**Adjustable
Clamp Co.**

216 N. Jefferson St., Chicago

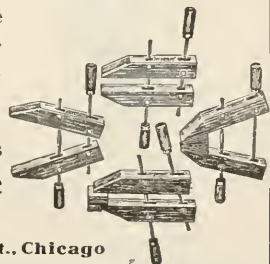

L-U-M-B-E-R

We Specialize in
Manual Training Lumber

No order is too large or too small to receive
our careful attention

John S. Benedict Lumber Co.
419 N. Halsted St. CHICAGO

MITER SAW BENCHES

The
"Tannewitz"
Universal
Double Re-
volving Ar-
bor Saw Bench with Sliding Table and Taper
Pin Gauges is the only logical tool for the wood
shop where frequent setting up is the rule and
accuracy is the goal. Send for bulletin.

THE TANNEWITZ WORKS
GRAND RAPIDS MICH

The Famous Books of W. H. TIMBIE and H. H. HIGBIE

By TIMBIE and HIGBIE
Essentials of Alternating Currents.

Enables grammar school graduates to
grasp and retain the fundamental infor-
mation given.

371 pages. 5 by 7. 223 figures. Cloth, \$2.25

**Alternating Current Electricity and Its
Application to Industry.**

Vol. I. First Course. Understandable
by beginners, yet complete enough to be a
foundation for more advanced study.

534 pages. 5¼ by 7½. 389 figures.
Cloth, \$3.50.

Vol. II. Second Course. Explains the
construction and operating characteristics
of the common types of alternating cur-
rent machinery.

729 pages. 5¼ by 7½. 357 figures.
Cloth, \$4.00.

*Answer books to the problems in all these books
are issued separately, paper-bound.*

John Wiley & Sons, Inc.

432 Fourth Avenue, New York

London: Chapman & Hall, Ltd.,

Montreal, Quebec: Renouf Publishing Co.

By W. H. TIMBIE.
Elements of Electricity.

Gives information which young men
need to answer practical questions as to
the application and possibilities of elec-
trical machinery.

553 pages. 5¼ by 7½. 411 figures.
Cloth, \$2.75.

Essentials of Electricity.

Explains facts and laws of good elec-
trical practice—for workmen in the elec-
trical trades.

271 pages. 5 by 7. 222 figures. Cloth, \$1.75.

Let us send you any Wiley book for Free
Examination—you may return them if not
satisfied.

WILEY FREE EXAMINATION COUPON
John Wiley & Sons, Inc.,
432 Fourth Avenue, New York City.

You may send me the following on 10
days' approval:

I agree to pay for the books or return
them within 10 days of receipt.

.....

.....

Name

Address

If teacher, state school.....

If not teacher, give reference.....

M. T. M. 11-21

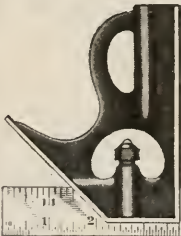

NEW
No. 65

LUFKIN

**"UNIVERSAL"
TRY AND MITRE
SQUARE
FOR WOODWORKERS**

HIGH GRADE YET POPULAR PRICED.
ACCURATE—DURABLE—WELL DESIGNED.

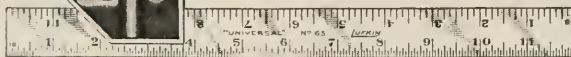

9-inch \$1.75
12-inch \$2.00

Distinct marking; movable yet secure head. Serves also as marking, height and depth gauge, and
separate rule. *If Unobtainable at Dealers Write Us Direct.*

Send for Catalogue

THE LUFKIN RULE CO.

SAGINAW, MICH.
New York

Marqueterie, Inlay Borders and Purflings for

Manufacturers and Vocational
Schools

Insets for Trays, Panels, Cabinets, etc. carried in stock.
Natural and Transformed Veneers in great variety.
Lines in Holly, Satinwood, Box, Mahogany and Black

J. BERNARD CO.

422 to 30 East 53rd St. New York

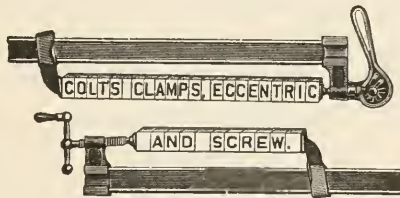

Forty styles of Quick Acting Clamps for the
Worker in Wood, Cement and in the
trades generally.

Your dealer will supply you.

Ask for catalog No. 296.

BATAVIA CLAMP CO.

237 Center Street

BATAVIA, N. Y.

RIGHTLY NAMED

We have recently mailed our SEVENTH ANNUAL CATALOG OF "HARD-TO-GET" MATERIALS to schools in all parts of the Country. In response many Instructors have written us that this catalog is most rightly named as it lists a large number of items impossible to obtain from the usual sources. This latest catalog of Cabinet Hardware, Furniture Fittings, Upholstery Supplies, etc., will be mailed promptly to any instructor.

CHEST TRIMMINGS

Solid Copper Bands and Fancy Designs. Coppered Nails, Locks. Handles, Hinges, Cover Supports. Also Chest Corners, Edge Binding, Hinge Plates and Handles in Hammered Old Copper Effect. Casters and Sliding Devices in various styles and sizes.

Dennison Glue Stanley Tools Johnson Stains

THURSTON MANUAL TRAINING SUPPLY COMPANY

Jobbers and Manufacturers

Anoka, Minnesota

ORDER NOW—DIRECT FROM US

Mechanical Drawing Instruments

AT OUR ATTRACTIVE WHOLESALE PRICES
AND SAVE ONE-HALF OF RETAIL PRICES

Set of Instruments as per Photo \$5.50

Construction of Solid Nickel Silver and Steel—Pocket
Case 8½ Inches by 4 Inches, and Lined with Velvet.

A Set of Instruments Every Manual Training Student
Can Afford—at a Big Saving and Perfect Satisfaction

Send for Catalog on Other Sets, Etc.

National Instrument Company

4700 North Hamilton Ave., Dept. M., Chicago, Ill., U. S. A.

Educational Toys

By LOUIS C. PETERSEN



A Complete Manual on Toy-Making

THIS book takes into account the child's viewpoint. The toys have a direct relation to his environment and are within range of his mental grasp and constructive ability. They appeal to his fancy and are within the child's power to construct. The fifty-seven toys include Animals, Wheeled Toys, Stationary Toys, Moving Toys, Puzzles, etc., made chiefly with the coping saw and easily constructed in the ordinary school room or in the home.

How to make each toy and how to finish and color is clearly told with additional information about the few simple tools and materials required. Full-size pattern drawings make it possible to trace from the book direct, while photographs show the toys complete.

Postpaid, \$1.80.

*Ask for a copy of our new 72-page
DESCRIPTIVE CATALOG*

The Manual Arts Press
Peoria, Illinois

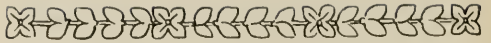

TRADE NOTES

COLORS FOR TOYS

TEACHERS looking for colors for toy-making will do well to send to The American Crayon Co., Sandusky, Ohio, for their sample card of tempera colors. This shows 22 colors which can be purchased in small jars especially suited to school use.

CHRISTMAS DECORATIONS

After the toy-making season in some schools will come the making of Christmas decorations. Among the first to be thought of are the Christmas tree ornaments. For this purpose The Prang Company are recommending their "Permodello." This is a new kind of modeling clay that will set like concrete when exposed to the air for a considerable time. When dry it takes color admirably. This opens a new and most interesting field for design work.

The Prang Bulletin,

A NEW MORTISER

A new machine recently put on the market by the J. A. Fay & Egan Co. of Cincinnati, Ohio, should be of special interest to woodworking teachers. It is known as their No. 472 Shaftless Motor

CABINET CLAMPS



Where Black Bros. Clamps are known there is no Second Choice.

KNOW THEM

Send for bulletin today.

THE BLACK BROS. CO.
Mendota, Ill.

CUSHIONS

AND

UPHOLSTERING SUPPLIES

KUNKLE, KARL CO.
126 N. Washington St. Peoria, Ill.

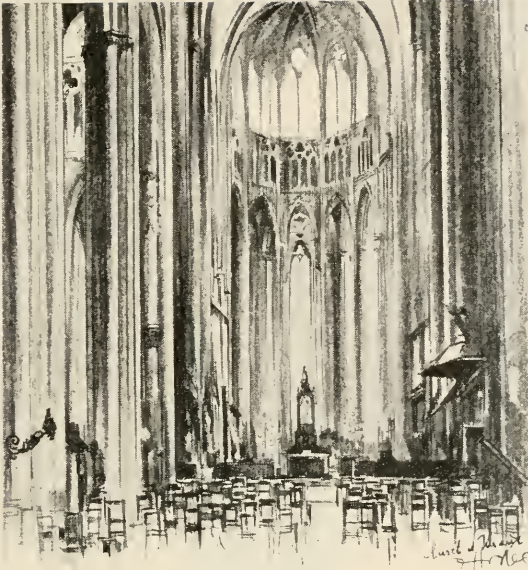

*The craft of master pencil
making is at your
disposal in*

DIXON'S ELDORADO

"the master drawing pencil"

*It will help your pupils
master their work in
pencil drawing*

*Free Samples Sent to Teachers
upon Request*

JOSEPH DIXON CRUCIBLE COMPANY

Pencil Department 19J

JERSEY CITY, NEW JERSEY

Buffalo Combination Woodworker

Twelve
machines
in one

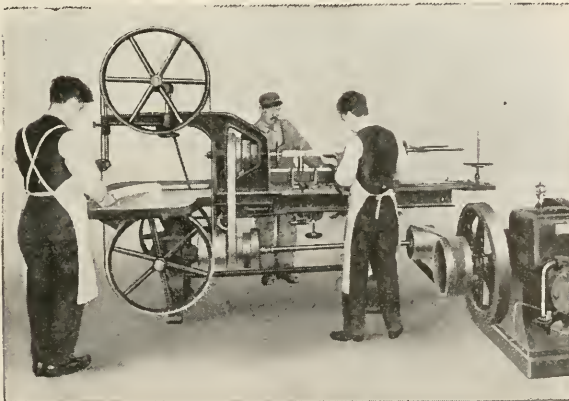

Three
men
can work
at one
time
without
inter-
ference.

With this machine it is possible to give a complete training in woodworking without an elaborate machine equipment.

Bulletin 360 will show how a small appropriation can be made to work wonders.

BUFFALO FORGE COMPANY
BUFFALO, NEW YORK

PARKS FOUR-IN-ONE

does anything in manual training
wood-working

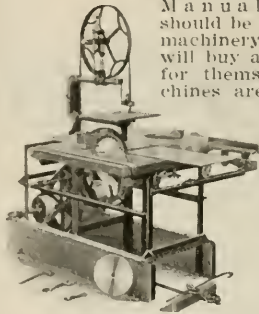

Manual Training Students should be trained on practical machinery — the type they will buy and use in business for themselves. Parks machines are practical, strong, durable, efficient. Practical carpenters, contractors, and cabinet-makers use and endorse them. Four-in-One complete—circular rip and cross-cut saw, band-saw, jointer and borer —\$200.00. Send for catalog.

The Parks Ball Bearing Machine Co.

1536-46 Knowlton Street Cincinnati, Ohio
Chicago Office and Show Room 617 Machinery Hall
Canadian Factory 200 Notre Dame E., Montreal, Can.
Western Office and Warehouse, 1113 Farnam St., Omaha

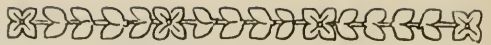

TRADE NOTES—(Continued)

Driven Vertical Hollow Chisel Mortiser. It is a handy and durable tool, entirely self-contained, takes up but small floor space, and is easy to operate. It mortises rapidly and accurately, without jarring or pounding, and makes a clean-cut mortise with sharp edges and square bottom. A descriptive circular illustrating and describing in detail this new machine will be mailed on request. Ask for their Bulletin J-31.

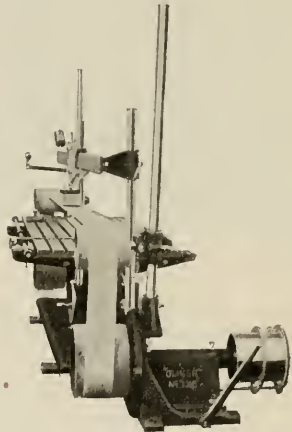

BELT SANDER

Another new machine recently put out by the Oliver Machinery Co. of Grand Rapids. This time it is a Belt Sander illustrated above. It is designed for rapid sanding and polishing of all kinds of line and edge molding, flat and straight surfaces and for sanding and finishing built up pieces such as cedar chests, desks, chairs, as well as all kinds of medium sized pieces of furniture. It is quick in action, convenient for the operator and is safe. This machine has many other features to commend it for school shop use. Write for a descriptive circular of their No. 126 Universal Belt Sander.

SMALL ENGINE LATHES

In their catalog No. 27 The Seneca Falls Manufacturing Co. of Seneca Falls, New York, give a very complete description of their line of "Star" lathes. This firm for the past thirty-five years have been building lathes complete in one factory. They have specialized on small lathes built in large lots to jigs, fixtures and gages, guaranteeing interchangeable parts and a high standard of perfection. Their line includes 9", 11", 12" and 13" screw cutting engine lathes. Their catalog No. 27 illustrates to good advantage the various sizes and styles in which these lathes are built, together with the various special features found only in "Star"

PARKS

Specialists in
Manual Training Lumber

Maisey & Dion
Hardwoods

KILN DRIED AND AIR DRIED
OFFICE & YARDS 2349 TO 2423 So. LOOMIS ST.

TELEPHONES
CANAL 1830
CANAL 1831
CANAL 118

CHICAGO
THE
Great Central Market

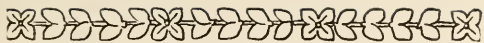

TRADE NOTES—(Continued)

lathes. Write for a copy of this catalog before you make your next selection.

BLOCK PRINTING

A unique booklet, entitled, "Block Printing in the Schools" has been published by the Sigmund Ullman Company, New York, manufacturers of high-grade printing inks.

The out-of-the-ordinary features of the booklet are the illustrations, four in number, which were printed direct from linoleum blocks.

The blocks, which are printed in five colors, were designed, cut, and printed by public school teachers. The printing was done in a school print shop.

The edition being limited on account of being printed direct from the linoleum (altho the edition consists of several thousand) it would be well for those desiring copies to write for them immediately. Requests should be mailed on school stationery to the Linoleum Block Printing Supply Company, 263 Whiton Street, Jersey City, N. J., under whose direction the booklet was planned and executed and who will handle the distribution of same.



Manual Training Bench, No. 16

which is furnished with one Abernathy Rapid Acting Vise, and with one drawer.

Ask for our new Catalog No. 27

C. CHRISTIANSEN
BENCH MANUFACTURER

2814 W. 26th St. CHICAGO, ILL.

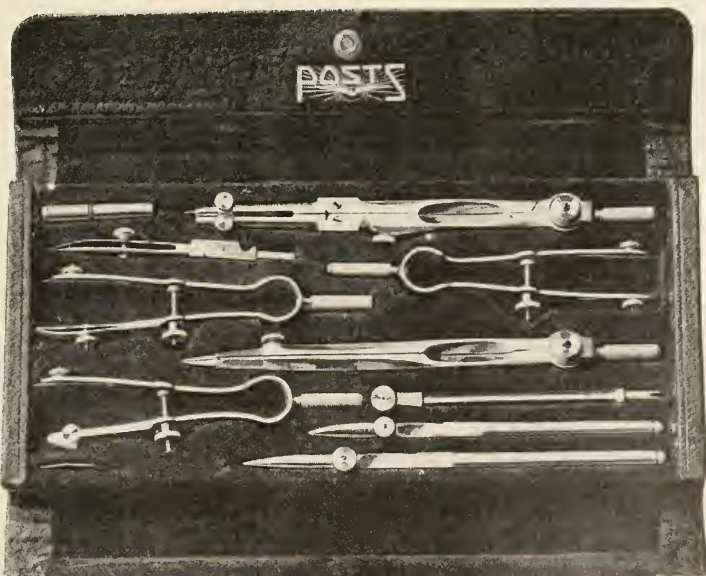

Special Offer Unusual Bargain

No. 1070C Set in Case Ruling Pen Compass, **\$2.50.**

No. 1071½C Set in Case Ruling Pen, Bow Pen, Hairspring Divider Compass, **\$3.00.**

No. 1073C Set in Case Ruling Pen, Bow Pencil, Bow Pen, Hairspring Divider Compass, **\$4.**

No. 1075C Set in Case Ruling Pen, 1½", Ruling Pen 5½", Bow Divider, Bow Pencil, Bow Pen, Hairspring Divider Compass, **\$5.**

POST PAID

LIMITED QUANTITY FOR IMMEDIATE ORDER ONLY

THE FREDERICK POST CO.

Salesrooms
319 S. Wabash Avenue.

CHICAGO

Main Office and Factory
Irving Park Station



CLASSIFIED ADVERTISEMENTS



Do you want to sell or want to buy some school shop supplies? Do you want to employ a teacher? Do you want a new position? Advertise your wants in these classified columns. Rate 20c a line, minimum \$1.00.

ELECTRICAL PROJECTS

BUILD "PEPCO" ELECTRIC TOASTERS—A useful and attractive project. Buy the parts from the Practical Electrical Project Co., Highland Park, Illinois. Reduced price during November and December.

UPHOLSTERY MATERIALS

UPHOLSTERY SUPPLIES FOR MANUAL TRAINING—We carry most things needed in the manual training departments such as, tools, imitation and genuine leathers, and upholstering supplies. Tray handles, catches and knobs, casters, mirrors, etc. Write for our Catalog. F. A. Rauch & Co., 410 So. Market St., Chicago, Ill.

CUSHIONS—You know your cushions will be made right when furnished by the Grand Rapids Cushion Company. Write for estimates on cushions and all kinds of upholstery supplies. Grand Rapids Cushion Company, Grand Rapids, Michigan.

CUSHIONS, APRONS, UPHOLSTERING SUPPLIES. If you make your own cushions we can supply the materials at reasonable prices. If you want complete cushions, we know how to make them, and our prices will interest you. Kunkle-Karl Co., 126 N. Washington St., Peoria, Ill.

MANUAL TRAINING LUMBER

FRANK PAXTON LUMBER CO., KANSAS CITY, KANSAS—We have for immediate shipment in any quantity: Plain and Quartered Oak, Red and Sap Gum, Walnut, Curley Redwood, Tennessee Red Cedar, Ash, Mahogany, Jenizero, Spanish Cedar, Redwood, White Pine, Poplar, Cypress, Maple, Sycamore, Holly, Beech and Magnolia. Write for price list and particulars.

AMERICAN WALNUT LUMBER—We carry a stock of over two million feet of Walnut Lumber, consisting of all grades and thicknesses from $\frac{1}{2}$ " to 4". Due to this large stock we are always in position to supply dry lumber for Manual Training use. Send us your inquiries. Frank Purcell Walnut Lumber Company, 12th Street & Belt Line, Kansas City, Kansas.

AROMATIC TENN. RED CEDAR BOARDS. Small shipments a specialty. Write us for prices delivered at your railroad station. Earthman Lumber Co., Murfreesboro, Tenn.

MORGAN MANUAL TRAINING MATERIALS—A perfect system of dry kiln enables us to give you lumber thoroughly dry. Carrying in stock large quantities of different woods permits us to fill your orders with the best selections. Write, sending us a list of the materials you desire. We will quote you attractive prices. Morgan Company, Oshkosh, Wisconsin.

LUMBER—Maisey & Dion, 2349 to 2423 South Loomis St., Chicago, Illinois, carry in stock a large and diversified stock of **MANUAL TRAINING LUMBER.** Fifteen years' experience with schools enables us to fill such orders satisfactorily.

HICKORY SPLINTS

HICKORY SPLINTS—HAND MADE, $\frac{1}{2}$ " wide material for chair and basket weaving. One dozen seats \$1.50, post-paid. Splints $\frac{3}{4}$ " wide, one dozen seats \$2.40. \$.25 extra beyond 5th zone. Cash with order. Prompt shipment. Rush your order. Hardin Splint Mfg. Co., Hawesville, Ky.

POTTERY SUPPLIES

COMPLETE POTTERY SUPPLIES and equipment for Schools, Studios and Laboratories. Write for new pamphlet. Wm. W. Wilkins, Lewis Institute, Madison and Robey St., Chicago.

BLUE PRINTS

FREE CATALOG AND SAMPLE—Blue Prints of Agricultural, Furniture Making, Mechanical Drawing, Wood Turning, Forge Work, Pattern Making and Whittling Problems. Make your work more practical. Work from blue prints. Schenke Blue Print Co., 1034 Carney Blvd., Marinette, Wis.

GRANDFATHER'S CLOCK—Blue prints, finishing material and instructions. Also works, dial, weights and pendulum can be purchased from us at surprisingly low prices. Send for particulars of our attractive offer. Clock Company, 1666 Ruffner St., Philadelphia, Pa.

BASKETRY

BASKETRY MATERIALS. Reeds, raffia, wooden bases, chair cane, Indian ash, splints, cane webbing, wooden beads, braided straw, rush, willow, pine needles, stencilling materials, books, tools, dyes. Catalogue and Directions, 15 cents. Louis Stoughton Drake, Inc., 34 Everett St., Allston, Station 34, Boston, Mass.

REED FOUNDATIONS AND SUPPLIES. Veneered tray bottoms, clear pine bottoms, lamp standards and fixtures, galvanized iron containers, finishing materials, etc. Send for catalogue. The Kessel and Nyhus Co., 1733 Stanford Ave., St. Paul, Minn.

PRINTING SUPPLIES

TYPE—Manufacturers of Metal Type, Wood Type, Reglet, Brass Rule and Printers' Supplies. In no trust or combination. Empire Type Foundry, Buffalo, N. Y., Delavan, N. Y.

PRINTERS' TYPE—The character of your printed product depends largely upon the quality of the type you use. Our material is manufactured to the highest standards, accurate, and will withstand long wear. Have you our catalog? Rettew Printing Co., Foundry Dept., Reading, Pa.

SCHOOL SHOP SUPPLIES

SODERING SUPPLIES, including the famous Allen Non-Acid Sodering Fluxes—in stick, paste, salts and liquid form; handy soder sets, sodering tools, aluminum soder and flux. As pioneers in the development of fluxes that far surpass muriatic acid, in every way, and as the original exponents of non-acid fluxes, the House of Allen has for 25 years maintained a position of leadership in the Arts and Crafts concerned with sodering. Send for our Bulletins. L. B. Allen Co. Inc., 4584 N. Lincoln St., Chicago, Ill.

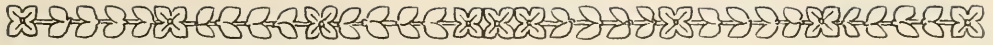

BOOK NOTES

ABOUT a year ago The Manual Arts Press published *Educational Toys* by Petersen and *Toy Patterns* by Dank. Both of these met with immediate approval. Teachers who were interested in the mechanism of toys and the grotesque in art were especially attracted to *Educational Toys*, while teachers looking for refinement in line and in design were pleased with *Toy Patterns*. The two together provided the teacher with a great variety of working drawings and suggestions useful in the upper four grades of the elementary school.

From a normal school instructor has come the following testimonial to the value of these two publications:

"At present I am using the plan and projects as outlined in the book and it seems that they get a firm hold and exert a strong pull upon the original interests and needs of boys and girls of the third, fourth, fifth and sixth grades."

A state supervisor of manual arts writes,

"I was very glad indeed to note the attempt which was made by both authors to bring the subject of toy-making and coping-saw work up to a level where it possesses not only artistic values but has been well organized and developed mechanically.

"I shall take great pleasure in placing these books on my recommended list and will also see that they find a place in the next Township Library List."

A manual training teacher writes of them:

"I am using this material with boys in this school, and it is filling the bill far beyond our expectations."

From the many reviews of these books that have been published the following discriminating statements have been gleaned:

(a) Referring to *Educational Toys*,

"It contains a collection of toys, not mere toys, but rather toys which take into account the child's viewpoint and his emotions; toys which have a direct relation to his environment and which are within range of his mental and constructive ability."

"It consists of an array of problems within the child's power, which excite and sustain interest, have real educational value, adapted to light-wood construction, and conform in size and complexity to the limited space and equipment of classroom conditions."

"How to make each toy and how to finish and color is clearly told, with additional information about the few simple tools and materials required. Full-size pattern drawings make it possible to trace from the book direct, while photographs show the toys complete."

"This manual, with the necessary tools, will be a far more satisfying Christmas gift than the elaborate manufactured toys."

"This book should have a place in the manual training department of every school."

"A first-class present for a child."

(b) Referring to *Toy Patterns*,

"This is a portfolio of toy patterns which have a distinct character and high artistic quality."

"This collection suggests all sorts of fascinating and delightful possibilities and will be wonderfully helpful to children, not only in the way of entertainment, but in the exercise of brain in the deft use of the hands."

"They are suitable for reproduction in the school or the home shop and should find wide use."

"It is an interesting holiday portfolio for any youngster who has a little knowledge of the use of tools."

SOME of the readers of this column will be interested in the following quotation from a letter from John F. Friese, author of *Farm Blacksmithing*. We asked Mr. Friese how he happened to write his book—what led him to put the material into book form. This is what he said:

"Thru a number of experiences on farms, and thru observation, I knew that farmers made many repairs on their farm equipment, and quite frequently made apparatus and labor-saving devices and implements. These latter were not always beautiful in design, but were substantial and served the purpose for which they were intended.

"In preparing for my first course in farm blacksmithing I cast about for objects that were frequently repaired or forged new by the farmer at his forge. There seemed to be nothing extensive in printed form that centered about farm problems, and nothing with definite dimensioned drawings or instructions for making. So I turned to the trade catalogs of farmers implements, tools, etc. From these we secured many illustrations which were worked into dimensioned sketches. I talked with a number of progressive farmers regarding the content of a farm blacksmithing course, and what things were considered most essential. After the first class was organized, the boys, sixteen in number, between the ages of sixteen and twenty-four, brought in repair jobs from their farms, and suggestions for repair jobs and new jobs. Thru these three principal agencies I secured by far the greater part of the material that was later put into the manuscript and drawings of *Farm Blacksmithing*."

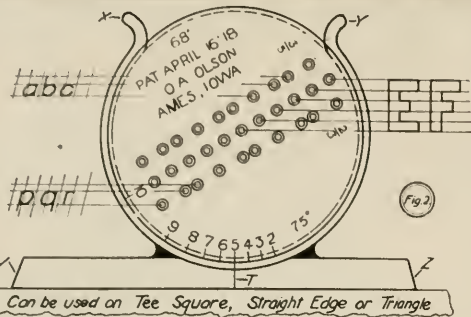

AMES LETTERING INSTRUMENT

It's the only instrument of its kind that allows the user to vary the heights of lettering by adjustment of the dial or disc. Slope lines can be drawn without any adjustment of parts.

7000 NOW IN USE

It is the only instrument of its kind that has holes spaced for three different systems of guide lines.

THE O. A. OLSON MFG. CO.
Ames, Iowa

Dealers and high school teachers in every city should write for prices and leaflet.

SIMPLIFY GRINDING

With Mummert-Dixon Oilstone Grinders. Five wheels for almost every class of grinding. They accomplish the work quickly and accurately. With this machine your students can experience the pleasure of sharp tools.



The Modern Edge Tool Sharpening Machines.

The Standard for all Industrial Schools

Five Leading Features
Coarse Oilstone Wheel
Fine Oilstone Wheel
Emery Wheel
Grinder Cone
Leather Wheel

Furnished for motor drive or with counter-shaft
Send for full descriptive bulletin

MUMMERT-DIXON CO., Hanover, Pa.

Lumber

All Kinds of Domestic and Foreign Woods.

Send for New Catalogue and Price List.

Frank Paxton Lumber Co.
Kansas City, Kansas

Give Your Pupils SHOP-WORK THAT PAYS

Let the Boys Build Phonographs

Imagine the pride and joy of your pupils in building their own phonographs (equal in quality to high-priced standard machines) either to sell or take home as a source of lasting pleasure. Think how this project will add to your popularity as an instructor. Building phonographs is easy, by our methods, yet it demands precision and delicacy of workmanship, the very points always emphasized in shop practice.

Send 10c for fine illustrated catalog

and full information about our co-operative plan for manual training teachers. We plan the work for you. We supply blueprints, tone-arms, motors, case material and all accessories at lowest prices. Detailed instructions furnished. Materials best obtainable, fully guaranteed. Our machines play any make record. Write us TODAY.

HOOSIER MANUFACTURING & SUPPLY CO.

PHONOGRAPH SUPPLY DEPT.

315 Baldwin Block, Dept. A.

Indianapolis, Ind.

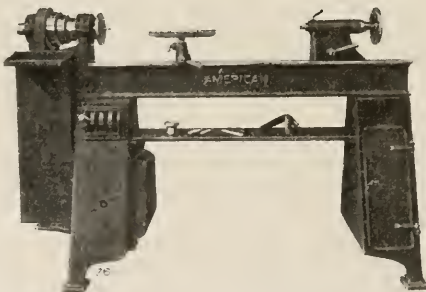

Manual Training Lathe with Motor in Base—24" to 72" Centers

AMERICAN School Equipment

High Quality Machines at Moderate Cost

SAW BENCHES
JOINTERS
PLANERS
BAND SAWS
WOODWORKERS



AMERICAN SAW MILL MACHINERY CO.

142 MAIN ST., HACKETTSTOWN, N. J.

MANUAL TRAINING MAGAZINE

EDITORS CHARLES A. BENNETT, Peoria, Illinois.
WILLIAM T. BAWDEN, Assistant to Commissioner of Education, Washington, D. C.

ASSOCIATE ARTHUR D. DEAN, Professor of Vocational Education, Teachers College, New York City
EDITORS FRANK M. LEAVITT, Associate Superintendent Public Schools, Pittsburgh, Pa.
WILLIAM E. ROBERTS, Supervisor of Manual Training, Public Schools, Cleveland, Ohio.

Business Manager L. L. SIMPSON.

Published monthly by The Manual Arts Press, 237 N. Monroe St. Peoria, Illinois.

Subscription Price, \$1.50; Canada, \$1.80; Foreign, \$2.00. Single Copies, 25 cents; Foreign, 30 cents.

Subscriptions, remittances, and manuscripts should be sent to THE MANUAL ARTS PRESS, Peoria, Illinois.

CONTENTS

THE BOY'S COURSE OR THE TEACHER'S COURSE?.....	<i>Frank W. Cheney</i>	183
FOREMANSHIP TRAINING IN THE LUMBER INDUSTRY..	<i>George Henry Jensen</i>	186
CONCLUSIONS REACHED IN TRADE-SCHOOL WORK.	<i>George A. Willoughby</i>	189
PLANNING A SCHOOL TO FIT EXCEPTIONAL CONDITIONS (Illustrated)	<i>Charles A. Bennett</i>	192
TOY-MAKING FOR HANDICAPPED CHILDREN (With photograph)	<i>Michael C. Dank</i>	198
EDITORIAL REVIEW FOR THE MONTH.....		202
Armistice Day—Spiritual Resources—Summer Manufacturing in Cincinnati—The Delgado Trade School in New Orleans—Disarmament Problems in the Schools—A Shop Recitation Period.		
A POINT OF VIEW.....	<i>Arthur Dean</i>	207
WASHINGTON CORRESPONDENCE.....	<i>William T. Bawden</i>	210
Bureau of Education Conference—Program of the Ann Arbor Conference—Two Dinner Conferences—Department of Education Petition—Another Step Toward Re-organization.		
IN FOREIGN COUNTRIES.....		211
The English Labor Party on Education.		
PROJECTS, PROBLEMS AND NOTES.....		213
Making Folding Chairs—A School Visit—Drawing of Coaster—A Handy Salt Container—A Rapid Method of Determining the Moisture Content of Wood—Coping with the High Cost of Lumber—V-Tool Holder.		
CURRENT PUBLICATIONS.....		220
FIELD NOTES.....		IV
From Minnesota—Southeastern Items—California Field Notes—From the Southwest—Around New York—National Society to Meet in Kansas City—Oklahoma Industrial Teacher's Meet—Industrial Teachers of Michigan Meet—Missouri Teachers in Convention—Time Limit for Reinstatement of War Risk Insurance Announced—Items of Progress—Eastern Art Association to Meet at Rochester.		
TRADE NOTES.....		XXXII
BOOK NOTES.....		XLI

This Magazine is kept for sale at McClurg's in Chicago, and Brentano's in New York.

Entered at the Post Office at Peoria as Second-Class Matter. Copyright, 1920, The Manual Arts Press.

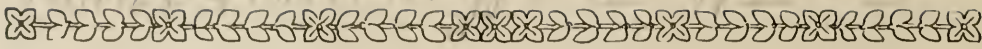

FIELD NOTES

FROM MINNESOTA

AT the Industrial and Household Arts Department meeting, Minneapolis Educational Association, November 4, Clyde A. Bowman, of the Stout Institute, told of some of his findings in an examination of 400 requests for various kinds of industrial teachers received at Stout Institute. The question appearing most frequently was, "Can the candidate handle 'classification' of students." In a graphic illustration he showed how the elementary school, grades 1-6, was preparation; how the junior high school, grades 7-8-9, was classification; how the various kinds of senior high schools and the vocational school, year 14-17, was preparation; how normal school was preparation; how the junior college was classification again; and how the senior college and graduate work was preparation.

About one-third of all requests are now for junior high school teachers, while four years ago there were none. The junior high school being in the classification period he held that the industrial teacher of this school had three big jobs, not one, namely, to analyze, to select, and to teach.

Officers elected to serve this department next year are Mr. Sturtevant, South High School, Minneapolis; Miss Monroe, South High School, Minneapolis; Mr. Berg, Central High School, St. Paul.

THE MANUAL TRAINING DIVISION

The Manual Training Division meeting had the largest attendance that it has had for a number of years. Ray L. Southworth, West High School, Minneapolis, analyzed the industrial teacher's job from many viewpoints. He pointed out that the industrial teacher's job was becoming far more than just teaching handwork. The teacher should be vitally concerned in the health and happiness of his pupils. He should be more concerned in making men, who will make jobs, rather than giving all attention to cramming facts and developing technic. He urged all manual arts teachers to read and know the seven cardinal objectives of education as outlined in Bulletin No. 35, 1918, Bureau of Education, that we may think and talk on the same level and in the same terms as academic teachers, that we will in all matters be shoulder to shoulder with them.

Some of the pertinent questions asked and discussed in Mr. Southworth's analysis of the industrial teacher's job were:

1) To what extent is the industrial teacher concerned with the seven cardinal objectives, personally and as a teacher?

2) If happiness and not license is a cardinal objective in industrial education, how do you or how would you devise methods to bring about this objective in your teaching?

3) Are rating scales, as per the chart, constructive in obtaining standards for the industrial teacher? Why?

4) It is said that we make groups and types in wholesale lots in our educational system at the expense of the individual. If so, how may this be corrected in vocational lines?

5) (a) Is 90% of the Industrial teacher's success due to his personality? Why? (b) Could a teacher be 90% personality and 10% teacher? Why or how?

6) Should a course in personal efficiency be an integral part of an industrial teacher's training course? Why?

7) From Bureau of Education Bulletin, 1918 Vol. No. 35. "Vocational education should aim to develop an appreciation of the significance of the vocation to the community, and a clear conception of right relations between the members of the chosen vocation, between different vocational groups, between employer and employee and between producer and consumer."

By Mr. Arthur Dean in the Manual Training Magazine, July 1921. "It (vocational education) is an attempt on the part of society to fit persons for profitable employment and to provide persons already employed with additional education helpful to their vocation." (a) Do you agree with these statements? Why? (b) In what way do these statements define the industrial teacher's job?

8) (a) Is art a national industrial asset? Why? (b) Is art a problem for the industrial teacher? Why?

9) (a) If an industrial student has a reasonable appreciation of the seven objectives, could you say that the industrial teacher had functioned in his job? Why? (b) What would you designate as a reasonable appreciation of each objective?

10) (a) To what extent should the subject of industrial relations be presented to the industrial arts student in our cosmopolitan high school? (b) Should this be presented by the industrial teacher? Why?

George K. Wells, Teachers College, Moorhead, told of his experiences in devising simple mechanical and written tests for woodworking students. His tests have covered several hundred students in nine schools and the results conform very closely



MECHANIC ARTS HIGH SCHOOL
BOSTON, MASS.

Create Student Interest

BY USING STANDARD EQUIPMENT

A student's interest is immediately aroused and consequently developed when dependable equipment is placed in his hands, which results in keen satisfaction combined with the best of his ability as shown in the finished work.

Sturtevant Forges

are designed with full knowledge of the duty they are expected to perform and with the wisdom gained from long experience of the best way to perform it.

Sturtevant Forges are easy to work with, convenient and trouble-proof. Their continuous satisfactory performances have met with the approval of Manual Training Instructors in the many schools where Sturtevant Forges are installed.

Our Engineering Staff will gladly help you plan.

B. F. STURTEVANT COMPANY

Hyde Park, Boston, Massachusetts
and all principal cities

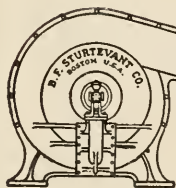

Sturtevant

REG. U.S. PAT. OFF.

PUTS AIR TO WORK

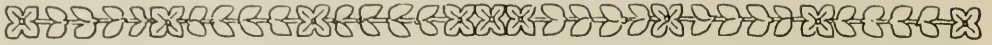

FIFLD NOTES—(Continued)

to the accepted curve of probability. Mr. Wells would like to get in touch with any teachers of woodwork who are interested, with the idea that the field of testing may be broadened, and that the findings in the form of an approximate standard might be arrived at for Minnesota. He will also be glad to receive suggestions for any kind of tests for woodworking students.

Clyde A. Bowman spoke of the various kinds and combinations of shopwork called for in 400 requests for teachers received at The Stout Institute. The greatest variety came in the junior high classification. He pointed out the distinction between the "vocational" work and teacher qualifications of the vocational school and vocational high school, and the "manual arts" work of the technical agricultural and commercial high schools. One phase of vocational work emphasized was that the students should be put thru the thinking processes the vocation produces in a workman.

Officers elected for the ensuing year are George Brace, St. Paul, president; William Von Levern, Hibbing, vice-president; and Mr. Hedlund, Minneapolis, secretary.

THE VOCATIONAL CONFERENCE

At the Vocational Conference held during the period of the State Convention, Charles R. Allen was the principal speaker on industrial education. One particular item of interest which he brought out was that scientific management had a limit of efficiency, and that the foreman who knows his job and his men cannot be replaced. More and more he is giving the orders for and qualifications of the needed employes to the employment managers. This was pointed out to indicate that foreman training is going to continue to be required more and more.

The conference organized itself and adopted a constitution. It will henceforth be known as the "Minnesota Vocational Education Conference." It will cooperate with the M. E. A. and meet at the same time as the annual convention. It was voted to affiliate with the National Society for Vocational Education. Membership dues of \$1.00 will be charged and this amount remitted to the National Society.

Mr. Kavel of Dunwoody was elected chairman for the coming year and G. A. McGarvey of the State Department, secretary-treasurer. The executive committee for this year will be appointed by the chairman and secretary-treasurer. They

will represent (a) agriculture, (b) commerce, (c) home economics, (d) trades and industries, (e) vocational guidance.

—JOHN F. FRIESE.

SOUTHEASTERN ITEMS

THE CITY of McComb, Mississippi was recently the recipient of a very fine gift. William McCoglin of that city donated the magnificent sum of \$400,000 for the purpose of establishing a trade school. It is hoped to make the school a leader of its kind in the South. The regulations of the Federal Vocational Act will be met in such a way that Federal aid might be used.

Wm. M. Wagner, of Cincinnati, Ohio is in charge of the shop work at Goldsboro, N. C. He is using the project method involving practical problems in both wood and metal.

For the year closing in June 1921, the Federal Board reimbursed 689 trade and industrial classes held in the Southern Region. The number for 1921 is almost nine times that of 1918. Trade instruction is very much in demand in the various lines of the textile industry.

A whole hearted effort is being made to have the trade and industrial work being done in the Richmond, Va. schools function to the fullest possible extent. The director, H. Clay Houchens, contributes the following. "Our work as planned for the session of 1921-22 does not differ materially from what we have been doing for the past sessions, nor does it differ much from the activities as conducted by the majority of the cities of our size thruout the country. We are conducting a number of Smith-Hughes all-day classes for machinists, electricians, wood-workers, and, in home economics; part time classes in retail selling; evening classes for home makers, machinists, electricians, and draftsmen; and training classes for teachers of the trade and industries.

Manual training and domestic science for general education are organized and conducted in our junior high schools largely with the thought of their value in developing appreciation of the processes and products of industry. The boys are given wood-work, printing, electrical work, mechanical and freehand drawing. The girls are given art, sewing, and cooking."

Harold Jennerjohn of Appleton, Wisconsin is teaching wood work in Raleigh, N. C. Mr. Jennerjohn is a graduate of Stout Institute, and formerly taught at Horicon, Wisconsin.

—FOREST T. SELBY.



Direct Motor Driven Woodworking Machinery

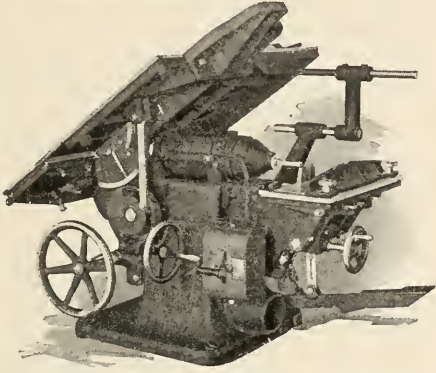

"Oliver" No. 80 Precision Saw Bench

This Motor-on-arbor Saw Bench is built with or without mortising and boring attachment, with plain or ball-bearing sliding table section.

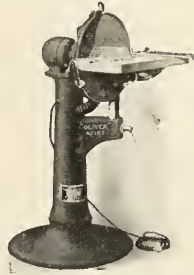

"Oliver" No. 182 Disk Sander

This direct motor driven 15-inch disk sander is portable and may be attached to any light socket. It is furnished with tilting and swinging table that raises and lowers. Self contained exhaust system for dust.

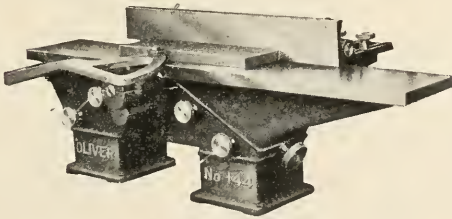

"Oliver" No. 133 Portable Jointer

In this direct motor driven Hand Planer and Jointer we offer a wonderful bargain. It is made in 4-inch and 6-inch sizes. Let us send you specifications and prices.

"Oliver" No. 91-D

Motor-on-Spindle Hollow Chisel Mortiser

The motor is built in the mortising head, saving pulleys, belting power, floor space.

The direct connected motor is desirable wherever it can be used. "Oliver" direct connects motors to their saw benches, swing saws, band saws, surfacers, jointers, lathes, sanders, boring machines, mortisers, oil stone grinders, etc.

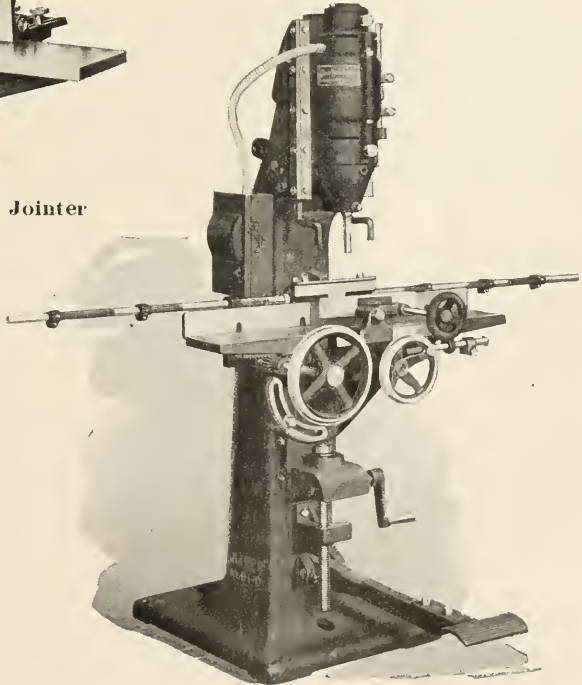

OLIVER MACHINERY CO.

GRAND RAPIDS, MICHIGAN, U. S. A.



FIELD NOTES—(Continued)

CALIFORNIA FIELD NOTES

THE TOWN of Hughson is taking to itself a new lease on life with respect to its manual training and industrial arts work in its Union High School. Early this term the local school board elected Philip H. D. Winsor to head up the work there. Mr. Winsor came from Idaho where he had been engaged in teaching auto-mechanics in part-time continuation schools. Upon coming to Hughson Mr. Winsor found that instruction in his special field, that of auto-practice, had not been offered. He, therefore, has had the pleasure of establishing that work there. He has had also the rare privilege of not only equipping his shop but also of building it. The structure he erected is, however, only a temporary one. It is the intention of the school authorities later to have erected a first class, up-to-date mechanic arts building, a building large enough and fully equipped to house all the manual arts activities of the local schools. In addition to the building already mentioned which was constructed to house the auto-practice work, there was recently erected a building in which the regular manual training could be conducted properly. The erection of this building was made necessary because of the destruction by fire of the structure in which the manual training has been carried on in the past. This second building is also but a temporary structure.

Martin E. Salmi, who had early this school year been elected to give instruction in auto-mechanics and machine-shop practice in Richmond, is finding himself most happily situated. Upon arriving on the scene at Richmond Mr. Salmi was given charge of a number of new and well equipped shops. These shops are housed in a newly constructed two-story building erected in the spring of this year. The building is occupied exclusively by the woodworking, metal working, and auto shops. The equipment is used not only by the regular students of the high school taking the industrial arts course, but also by other high school students, and by part-time continuation pupils, and by adults coming to evening school.

In the city of Marysville, N. J. Cutler is finding himself most interested in his new line of work. Up to this year Mr. Cutler has been engaged as cabinet worker, stair builder, hardwood finisher, and for many years, as builder and contractor. During the past two years he attended, in the evening, vocational teacher training classes which were conducted in Oakland under the provisions of the Smith-Hughes Act. It was upon the completion of the teacher training course he became

eligible for the Marysville position and was recommended for it. The equipment which the Marysville school department possesses comprises a well designed cabinet shop equipped with all the necessary tools for the kind of cabinet work done generally in schools. There is also a good forge shop and a well equipped automobile shop. These shops are all in one building which is set apart for manual arts work. It is Mr. Cutler's plan to have the students carry on their work on a commercial basis. He hopes thereby to create in his shops the true commercial shop atmosphere of economy of time and labor in production. Most of the work carried on under this system will at first be such as it is necessary to do for the local schools. As Marysville is a great center for duck hunting, one of the first production jobs was the making of decoy ducks. These were produced from 6" x 6" redwood, and properly painted when carved to shape.

—CHARLES L. JACOBS.

FROM THE SOUTHWEST

AT the Texas state meeting of the industrial arts teachers last winter, it was voted to divide the state into five districts for the purpose of organizing district clubs with the purpose in mind that these clubs would be of large benefit to the teachers in the respective districts. The state is to be divided geographically as follows: North Texas, South East Texas, South Texas, Central Texas, and West Texas.

The north Texas division met on October 29 at Arlington, near Fort Worth. Some fifty industrial arts teachers, including manual training, home economics, applied arts and related subjects, were present. F. P. Hall of Grubbs Vocational College was made temporary chairman and an interesting program was carried out. In the permanent organization, Hugo J. Vitz of the Denton Normal College was elected chairman and Mrs. W. Chamberlain of John Tarleton College at Stephenville was elected secretary. The high schools of Dallas and Fort Worth were well represented. Another meeting will be held in the spring, and the organization promises to be of much help to teachers of these subjects in North Texas.

The industrial arts teachers of Texas will meet with the State Teacher's Association at Dallas March 24, 25, and 26. The state being so large it has been found more convenient for the industrial arts teachers to meet in connection with the state association. A good program has been prepared, and among the speakers for the occasion

Industrial Correspondence University

PHILADELPHIA, PA.

ANNOUNCEMENT

PRESIDENT T. J. FOSTER takes pleasure in advising all who are interested in industrial and vocational affairs that the Industrial Correspondence University is prepared to enroll students for the best Mechanical Drawing, Architectural Drafting, and Blue Print Reading Courses that have ever been offered to the public.

Associated with President Foster, as Dean of the University, is Harry S. Bitting, President of The Williamson Free School of Mechanical Trades. Mr. Bitting has selected as his associates in the preparation and arrangement of all the technical courses, Mr. James A. Pratt, Mech. E., Director of The Williamson Free School of Mechanical Trades, and Frederic S. Crispin, C. E., Professor of Mechanical Drawing, Germantown High School, Philadelphia, Pa.

Mr. Pratt, personally, recently completed our Blue Print Reading Course which is a masterpiece of its kind, and we unhesitatingly recommend it, not only for students, apprentices, and shop workers, but for every teacher in the vocational educational field.

By our original and unique plan of sale all of our courses will be sold in units as Freshman, Sophomore, Junior, and Senior. A student enrolling will not be required to pay cash or part payment for more than a single unit at a time. Should he fail to complete this unit, or decide not to go on with the work after he completes it, it will not be necessary for him to make additional payments. After completing the first unit he may go on with the second, and so on, to the completion of the course.

In addition to the regular student enrollment plan of sale, either for cash or on the part time plan, we have decided to sell the courses at a very special price to teachers, without service, and at a still more moderate wholesale price, in lots of ten or more, to school organizations, without service, by which we mean that it will not be necessary for them to send in lessons for correction.

If interested, either as an individual or from a teacher's or principal's viewpoint, with the thought of adopting the courses, check the coupon at right and mail it to us, after which you will promptly receive full information.

Department M,

Industrial Correspondence University, Inc.,

1504 Locust Street, Philadelphia, Pa.

Without expense or obligation on my part, please give me full information concerning the course which I have marked X.

- | | |
|--|--|
| <input type="checkbox"/> Blue Print Reading (Building Trades) | <input type="checkbox"/> Blue Print Reading (Blacksmith) |
| <input type="checkbox"/> Blue Print Reading (Mechanical Trades) | <input type="checkbox"/> Tracer |
| <input type="checkbox"/> Blue Print Reading (Plumbing and Pipe Fitting Trades) | <input type="checkbox"/> Mechanical Draftsman |
| <input type="checkbox"/> Blue Print Reading (Structural Iron Workers) | <input type="checkbox"/> Architectural Draftsman |
| <input type="checkbox"/> C. P. A. Exams. | <input type="checkbox"/> Employment Manager |
| | <input type="checkbox"/> Expert Accountant |
| | <input type="checkbox"/> Cost Accountant |
| | <input type="checkbox"/> Auditor |
| | <input type="checkbox"/> Commercial Law |
| | <input type="checkbox"/> Financial Independence |

Name

Street and Number.....

City and Post Office.....State.....



FIELD NOTES—(Continued)

will be Dr. Prosser of Dunwoody Institute, Minneapolis.

A recent report from James T. Ryan, Phoenix, Arizona, State Supervisor of Trades and Industries, states that "the growth and interest in this work (trade and industrial education) is very rapid and we are expecting an enormous increase for the coming year. We have at present sixteen evenings schools classes, six part-time classes, and ten day trade classes. The state has participated in carrying on these classes to the extent of paying three-fourths of all teachers salaries in any class which follows the provisions as outlined by the Smith-Hughes Act, as interpreted by the Federal Board."

—E. A. FUNKHOUSER.

FROM NEW JERSEY

NEW JERSEY STATE MUSEUM OFFERS
FREE SLIDE SERVICE

NEW JERSEY shop teachers who have access to a stereopticon will be interested in the Lending Collection offered by the New Jersey State Museum of Trenton, N. J.

About fifty sets are available covering a wide range of industries. These sets should prove to be great aid in teaching. Some of the topics are: "How Paper is Made," "Making of Saws," "Iron and Steel," "Asbestos," "Forestry," and "Mining Industries."

The museum announces that schools or other responsible organizations of New Jersey may make use of its lending collections, with the understanding that they are to be used with care and are to be returned to the museum, or shipped according to instructions received, with a report of the approximate number of persons reached by the exhibit borrowed. Damage to material, other than ordinary wear, will be charged to users. Borrowers must pay transportation both ways. Full information can be obtained by writing to the museum.

MR. M. W. HAYNES LEAVES BAYONNE

In the September issue of the Manual Training Magazine an announcement was made of Layton S. Hawkin's resignation from the Federal Board of Vocational Education to become Director of Education for the United Typothetae of America. Since this announcement was published the appointment of M. W. Haynes as assistant director has been made public. Mr. Haynes work will be the editing of courses of instruction for apprentices in the printing schools and shops under the control of the Typothetae, also the training of instructors of printing. Mr. Haynes began his new work in Indianapolis November 1, 1921.

Mr. Haynes is particularly well qualified for this work by virtue of his service as editor of courses of instruction for use in training disabled soldiers, which work was carried on under a joint committee of the Surgeon Generals' office of the United States Army and the Federal Board for Vocational Education. The plan adopted for this work is the same as will be employed by Mr. Haynes in his new field, and is as follows. A list was first made of the various subjects in which instruction was to be provided. These subjects were then broken up into short units for which pamphlets were prepared including both self teaching instruction for the student and guides for the instructor. The pamphlets used were written by specialists and conformed to the standard specifications issued by the committee for guidance and standardization of instruction material.

Mr. Haynes writes. "I am impressed with the value of this plan in organizing such an extensive scheme of instruction as the Typothetae proposes. It is one of the most effective undertakings in real vocational education that has yet been attempted, and is begun under conditions that will be more favorable to success than can be found in a public educational work whether under a local city school board or even under a government agency. The development of this work should be followed with interest by vocational education workers thruout the country."

EDWARD BERMAN IS MADE PRINCIPAL
OF BAYONNE VOCATIONAL SCHOOL

The position made vacant by Mr. Haynes' appointment will be filled by Edward Berman. Mr. Berman is a graduate of Sheffield Scientific School, and Yale University. He taught mechanical drawing for six years in Bayonne High School, was instructor in apprentice classes in the Singer Manufacturing Company for several years and for the past three years has been principal of Americanization classes conducted by the Bayonne Board of Education. In this latter capacity he has developed very intimate and cordial relations with the various local industries which will prove a valuable asset in his work as principal of the Vocational School.

NEWARK TO HOLD EXAMINATION FOR TEACHERS
OF MANUAL TRAINING IN ELEMENTARY SCHOOLS

An examination of candidates who desire to qualify as teachers of manual training in elementary schools will be held at the Central Commercial and Manual Training High School building, High and

The School Paper

Published for the purpose of convincing educators of the educational value of printing in connection with academic and vocational instruction in public schools.

VOL. 1

JERSEY CITY, NEW JERSEY

No. 2

The Value of Schoolpapers

WHAT the newspaper is to the general community the schoolpaper is to the school community. Both possess uncommon interest to their readers by the publishing of news items and both have the power of moulding public opinion. One influences mature minds; the other influences the immature minds. Both are informative and very educational. Especially is this latter statement true as regards schoolpapers.

The schoolpaper has one distinct advantage in educational value—it is the product of its readers. To be successful it must represent the combined effort of every class in the school and be of interest to every student enrolled in those classes. The academic classes may be assigned the task of collecting news, preparing interesting articles, and revising the printers' proofs for errors in English construction, spelling and typography; the art classes may have charge of the illustrations and general typographic arrange-

ments; the commercial classes may look after the business end of the publication, such matters as collecting money for subscriptions or advertisements, disbursements for paper, inks, etc. The actual type composition, presswork, and binding will be done by the printing classes.

Surely no other school problem can combine into a single educational unity practically the entire facilities of a school as does the schoolpaper.

With the installation of printing instruction in a school the academic subjects are generally revitalized. English, grammar, spelling and mathematics take on a different mean-

ing to students who have hitherto regarded them as necessary evils. Taught in conjunction with printing, their great value as the vital elements of education is realized.

Information: The Education Department of the American Type Founders Company employs the services of professional educators, efficiency engineers and trained salesmen to aid you in establishing printing courses in your schools. With this company the word "service" is spelled H-E-L-P.

PRINTING, in addition to embodying all other advantages of manual training, brings in language work—and this correlation of English and manual training is not to be had in other handwork subjects.

For information write F. K. PHILLIPS, Manager, EDUCATION DEPARTMENT

American Type Founders Company

300 Communipaw Avenue



Jersey City, New Jersey

Boston, Mass.
New York City
Philadelphia, Pa.
Baltimore, Md.
Richmond, Va.

Buffalo, N. Y.
Pittsburgh, Pa.
Cleveland, Ohio
Cincinnati, Ohio
Atlanta, Ga.

Los Angeles, Cal.
Winnipeg, Canada

Chicago, Ill.
Detroit, Mich.
St. Louis, Mo.
Milwaukee, Wis.
Minneapolis, Minn.

Kansas City, Mo.
Denver, Colo.
Portland, Ore.
San Francisco, Cal.
Spokane, Wash.



FIELD NOTES—(Continued)

New Streets, Newark, New Jersey on Saturday December 10th, 1921, beginning at 9:00 A. M.

The schedule of salaries for the position is from \$1700 to \$3000 according to experience and fitness.

The examination, which will be open to men only, will consist of a written examination covering the following subjects: history; principles and methods of teaching manual training; mechanical drawing; structural and decorative design.

A practical test of the candidate's technical ability consisting of the working out of a shop problem will be a part of the examination.

Candidates who wish to take this examination must file an application blank with the Superintendent of Schools, City Hall, Newark, New Jersey. Blanks on which to make formal application can be had upon request.

—ALLEN D. BACKUS.

AROUND NEW YORK

PUPILS in the East Side Continuation School will publish a school paper shortly. Jacques C. Rosenblum, instructor in salesmanship, is in charge. There will be ten editors, one for each half-day section. The classes in typewriting are giving the pupils practical experience in taking dictation, and in letter-writing. The pupils take dictation from the instructor, and letters are written and sent to different firms for the purchase of goods.

The machine shop and carpentry shops are getting the equipment that was ordered last term, and the boys are showing great interest in their work.

Every school in the city kept open house during the week commencing October 10. The buildings were open for inspection, and all classes were in session. Reports from the principals of the schools indicate that a large number of parents and other citizens visited the schools, taking advantage of the opportunity to observe the work that is being done. In a series of meetings held at the different schools for parents, one of the special features was the dedication of new buildings.

At a meeting of the New York Principals' Association, held in the Wanamaker Auditorium, Broadway and Ninth St., general approval of the American Federation of Labor's contribution to the educational platform was voted. The association approved the report of its committee on educational problems, analyzing the recommendations made by Peter J. Brady in his address at Albany in 1920 in behalf of the committee on education of the Federation of Labor.

The association gave its assent (1) to the need of continuation schools to give further training to the

boys and girls who must leave the regular day schools before their education is completed, and their habits formed; (2) to the need of experienced and trained teachers in mechanical, industrial and commercial subjects, at a salary that will attract able and experienced workmen to take up teaching; (3) to the need of sufficient officers in the department of attendance of the state to enforce the attendance of truant children; (4) to the great necessity of rapidly decreasing the number of illiterates, and the substitution of English as the speaking and reading language; (5) and censorship of the alluring statements made by certain private schools whereby many pupils are attracted, and their time and money spent without profitable return.

While the school problem committee was not in accord with the recommendation asking that not more than twenty-five children be placed in one class or under any one teacher, and that every opportunity for physical training and play be given, the Association approved the stand with this qualification: "we realize that conditions will not permit of the immediate attainment of this ideal, but we shall continue to work for its realization." The Association went on record as not being in accord with the statement, "that the public schools system of the United States was created because of the insistent demand of our pioneer trade unionists," because it could find no authority which warranted its general application.

As to the statement that "several training schools or colleges for trade and vocational teachers should be established" the Association in dissenting explained, that there are schools now existing where this instruction can be given and recommended that such courses should be provided.

With reference to Mr. Brady's recommendation that industrial history as it is related to the organization of the workers, should have a foremost place, the Association approved the statement of its committee "We cannot see why the history especially describing the evolution of the trade should be added to the general history now studied in the schools. All efficient technical schools now take up the history of the work and the advances made in the trade or occupation since its beginning."

Other recommendations with which the Association was not in accord were that the continuation school period should be twenty hours a week until the pupil is eighteen years of age; that no child who has not passed at least the eighth grade, no matter what the age, be permitted to leave school; and the recommendation requesting the creation of a legislative commission to coordinate the activities of

How many boys know?

Do your boys know what is meant by the "Irwin Solid Center Principle?"

Do they know the parts of a Bit?—the shank, the twist, the head, the screw, the spur, the cutter, the throat, the "hang?"

This Book tells them the story

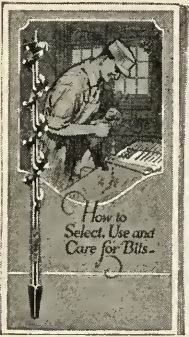

Do they know how a bit is made, annealed, tempered?

Do they know that the proper care of a Bit will double its life?

Do they know "How to Select, Use and Care for Bits?"

Do you know that we are the originators and exclusive manufacturers of the genuine Irwin Solid Center Bits?

Write for as many as you require.

They are Free.

Do you know that Irwin Bits are the standard wood boring tools of America?

Will you permit us to assist you in your work of training and developing the mechanical genius of your boys?

Write to us freely for advice and helpful counsel—we like to help.

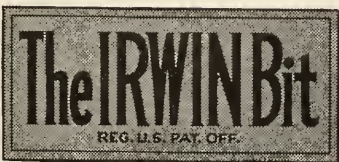

The Irwin Auger Bit Co.

245 Grant Street

WILMINGTON, OHIO

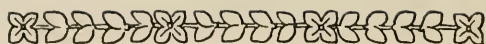

FIELD NOTES—(Continued)



No. 850

STANLEY TOOLS IN CABINETS - BOXES and SETS

THE well known Stanley Tools are now made up in several assortments, each assortment in a Cabinet, Box, Set (or roll.)

This is the best way to purchase tools—and the best way to own and use them.

A fine example of the new Stanley Tool Cabinets is the No. 850, illustrated above. See the entire line at your hardware dealer's to-day.

Illustrated folders (15L) gladly sent on request.



THE STANLEY RULE & LEVEL PLANT.
THE STANLEY WORKS
NEW BRITAIN, CONN. U.S.A.

*Manufacturers of Wrought Hardware and
Carpenter's Tools*

the departments of education and health and the industrial commission, in order that existing laws be more generally enforced.

The committee on educational problems reported it was in doubt with reference to the following and could not state its position until the text was made more clear:

"That in the period from fourteen to sixteen no girl or boy be permitted or forced to specialize in one trade or calling; and that surgical and medical treatment as well as dental and optical attention be given all children."

At a recent meeting of the Board of Education Mr. Arthur Sowers strongly advocated a repeal of or an amendment to the continuation school law so as to enable the working boy who wants to attend evening school to do so. Mr. Sowers said that there should be either continuation schools or evening schools, as the work was parallel excepting that the evening schools were recognized by the regents, while the continuation schools were not.

In order to keep within the budget appropriation for evening school classes in trade subjects it has been necessary for the department of education of New York City to curtail the number of sessions in those classes from one-third to a half for the remainder of 1921. The department lacks about \$30,000 of the amount required to keep the classes going for the full number of sessions, but rather than to cut the season short it was to reduce the number of sessions so that classes formerly in session four nights a week would meet but two nights and classes that had been in session two nights would meet but one night a week from now until the end of the calendar year. The classes were reduced for one week and the demands of the students were so great that the School Board appropriated additional funds to meet the deficit.

—W. H. DOOLEY.

NATIONAL SOCIETY TO MEET IN KANSAS CITY

THE FIFTEENTH annual convention of the National Society for Vocational Education will be held in Kansas City, January 5 to 7. This meeting promises to be one of the largest in the history of the organization.

The program committee of which C. A. Prosser is chairman is planning to make the convention of direct and practical benefit to those attending. To this end two full days will be devoted to sectional meetings under the following divisions: (1) agricultural education, (2) industrial education, (3) commercial education, (4) homemaking education,



*Join the Ranks of the
Satisfied Users*

No. 400 "Lightning" Manual Training Lathe

The Standard Lathe for School Work

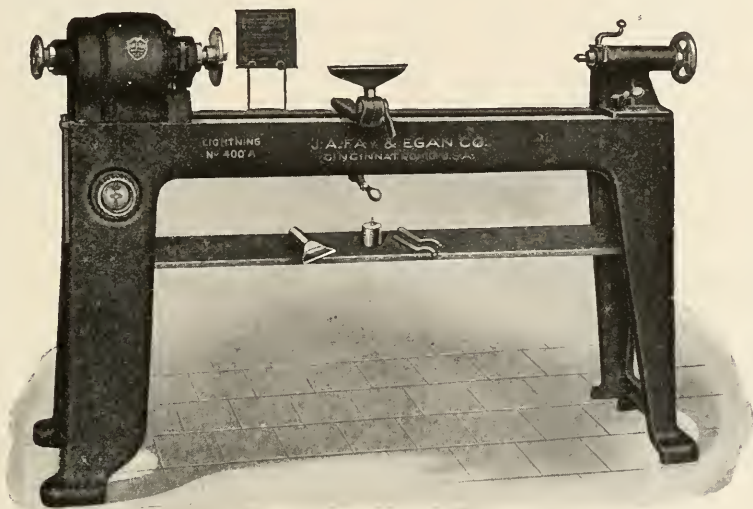

Type A—Direct Current.

Totally Enclosed Variable Speed Motor Headstock and New Built-In Control.

JUST A FEW OF THE MANY SCHOOLS WHICH HAVE INSTALLED A NUMBER OF "400" LATHES

Boston "Tech," Cambridge, Mass. (33)

Germantown and Westside High Schools, Phila., Pa. (35)

Grover Cleveland High School, Cleveland, Ohio (31)

Cincinnati Public Schools, Cincinnati, Ohio (31)

Board of Education, St. Louis, Mo. (31)

Highland Park Schools, Highland Park, Mich. (14)

Board of Education, Baltimore, Md. (12)

Charleston High School, Charleston, S. C. (10)

Write for Special 8-page Bulletin for Further Information.

J. A. FAY & EGAN COMPANY

ESTABLISHED 1830

**World's Oldest and Largest Manufacturers
of Woodworking Machinery**

730-750 W. Front St.

CINCINNATI, OHIO, U. S. A.

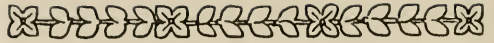

FIELD NOTES—(Continued)



THIS is one field in which "passably good" products cannot satisfactorily serve their purpose. The indifferent care received by Laboratory Furniture in a school or college, coupled with the strain put upon cabinet furniture by the unequal heating of such institutions, soon puts a definite limit to the usefulness of any Manual Training equipment not built of the superior materials and workmanship of

Kewaunee

Manual Training Furniture

The Kewaunee Book will interest Educational Executives who are considering the installation of new manual training equipment. Illustrates and describes our complete line and explains our free planning service.

Write us at Kewaunee for your copy.

Kewaunee Mfg. Co.
LABORATORY FURNITURE EXPERTS

111 Lincoln St.

KEWAUNEE, WIS.

New York Office, 70 Fifth Avenue

BRANCH OFFICES:

Denver	Spokane	Los Angeles
Phoenix	Columbus	Jackson, Miss.
Chicago	Little Rock	Toronto, Can.
Atlanta	Minneapolis	Alexandria, La.
Houston	Kansas City	Oklahoma City



Manual Training Bench No. 1904

Has accommodations for three students.

(5) part-time and continuation schools, (6) training in industry, (7) industrial rehabilitation, and (8) teacher training.

The mention of a few of the topics which will come up for discussion will give a suggestion of the importance of this conference. In the Industrial Education Section of which Ben. W. Johnson, University of California is chairman, "Industrial Courses in the Compulsory Continuation School" and "Relation of Industrial Education to Apprentice Training" are two of the five topics listed on the program.

Chas. R. Allen is the chairman of the Training in Industry Section. Foreman training, apprentice training, and the training of women in industry, are some of the problems which will come before this group. The Part-Time Education Section, whose chairman is George P. Hambrecht, State Director for Vocational Education, Wisconsin, has such vital topics as "Vocational Guidance and its Relation to Working Children," "The Attitude of Employers Toward Compulsory Part-Time Education" and "Development of Part-Time Education in the Twenty-two States with Compulsory Acts" planned for its program. The Teacher Training Section with George E. Myers, Professor of Vocational Education, University of Michigan, as chairman, will give particular attention to "Training Teachers in Service," "Job Analysis in Teacher Training," and other problems full of meaning for the present day teacher trainers; while the Industrial Rehabilitation Section under the chairmanship of R. M. Little of New York, will have among its topics "Developments in the Field of Industrial Rehabilitation" and "Methods of Retraining Physically Handicapped Persons."

A number of special features have been arranged for the Kansas City meeting. A very extensive vocational building plans exhibit is being arranged for. This exhibit will include blue-prints of the floors and elevations, photographs and data showing type of construction and cost of various types of buildings that have been erected thruout the country for vocational education purposes.

Another feature of the convention will be an exhibit of unpublished material in the field of vocational education. The vocational education movement is so new that a great deal of valuable data has never appeared in printed form. This exhibit will bring to the rank and file of teachers a wealth of material that will be valuable to them in developing their work.

For a copy of the final program, which will be ready for distribution about December 15th, write

LITTLE GIANT

MANUAL TRAINING DEPARTMENT

Special Equipment

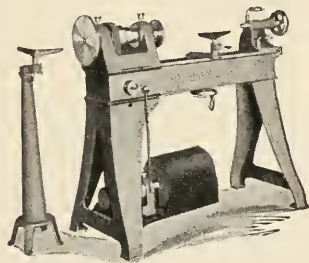

LITTLE GIANT WOOD LATHES

Individual Motor Driven, or Belt Driven from above or beneath.

Furnished with either Bench or Floor Legs. Wide choice of optional tools and equipment. Four speeds.

Many new, exclusive and practical features. All bearings are Hyatt High Duty Roller Bearings which greatly reduce power required. Ball Thrust bearings at all points of end thrust.

Sold on 30 days trial, and GUARANTEED FOREVER against defective material and workmanship.

LITTLE GIANT METAL LATHES

Individual Motor Driven, or Belt Driven from above or beneath.

Furnished with either Bench or Floor Legs. Wide choice of optional equipment. Three speeds.

Many new, exclusive and practical features are also found on our metal lathes. They are fitted to receive attachments for grinding, milling, gear cutting, etc., all of which we will furnish at a small fraction of the cost of a separate machine for such work.

Sold on 30 days trial and GUARANTEED FOREVER against defective material and workmanship.

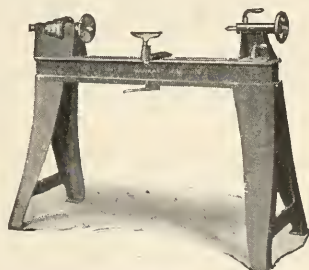

LITTLE GIANT POWER HAMMERS

Individual Motor Driven, or Belt Driven from above. Hundreds of different form-forging dies for instruction purposes.

Standard equipment with leading Technical and Manual Training Institutions.

Sold on 30 days trial, and GUARANTEED FOREVER against defective material and workmanship.

DO NOT OVERLOOK

Metal Working Equipment in your school. Wood can never be made anything else, while metal working and alloying are in their infancy.

The Industrial Leaders of the world, to a very large extent, began as metal workers.

Wood working is artistic, and trains mind, eye and hand to deftness. Metal working does all this, and more. It is also practical, and the graduate invariably finds a position waiting for him, while the wood working department graduate usually takes up something else and his instruction is forgotten.



Little Giant Equipment for Technical and Manual Training Schools consists of a full line of all metal and wood working machinery including accessories and tools for same.

On Motor Driven Equipment, information will be required as to Current, Voltage, Phase and Cycles of Motor.

Our business commenced in January, 1876, more than 45 years ago, and our Little Giant Products are used throughout the world. We are anxious to serve you for we can do it well.

Quotations and descriptive literature can be secured from any jobber, or direct from us.



LITTLE GIANT COMPANY

220 ROCK ST.

MANKATO, MINN., U. S. A.



*Birmingham High School
Birmingham, Ala.*

Forge Shop Equipment

Buffalo fans and forges are rendering excellent service in forge shops throughout the world. We are able to offer typical layouts with photographs of installations which will enable the proposed user to determine the number of forges possible to install in any space available.

Our Engineering Department is ready to give you any information on supplying blast and removing smoke and gases.

Write for Catalog 205-31.

Buffalo Forge Company
BUFFALO, N. Y.

“Buffalo”

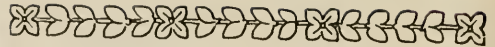

FIELD NOTES—(Continued)

to the office of the National Society for Vocational Education, 140 West 42d Street, New York City.

OKLAHOMA INDUSTRIAL TEACHERS MEET

THE Industrial Education Division of the Oklahoma Educational Association held its second annual conference November 4-5 at Tulsa, Oklahoma.

E. E. Oberholtzer, Superintendent of Tulsa City Schools, gave an address of welcome to the association in which he raised the question, “Is manual training failing?” He answered his question by saying, “If manual training is failing it is the teacher who is failing. He is not selling his work.”

The chief speakers of the conference were R. W. Selvidge, Professor of Industrial Education, University of Missouri, and O. B. Badger, Director Industrial Education, Wichita City Schools, Wichita, Kansas.

Mr. Selvidge took as the principal theme of his addresses, the aims of manual training, how to find those aims and use them in selling the work to the superintendent and the public, and how to make use of the aims in teaching the work to the classes.

Mr. O. B. Badger interested the conference in his discussion of the “Type of Shop Courses Needed” and in his report on “The Present and Future Shop Courses in the Wichita Schools.”

The work of the Industrial Education Division thus far was approved and its success in the future assured when the large number present voted unanimously to continue as now organized and not unite with the Oklahoma Society for Vocational Education.

The report of the Committee on Certification of Manual Training Teachers, which had been approved by State Superintendent R. H. Wilson, was accepted with a few minor changes. Mr. Selvidge, who has made a study of this question, said this was the most advanced step taken by any state in this direction.

The following officers were re-elected: President, DeWitt Hunt, Director of Shop Practice, Oklahoma A. & M. College; Vice-President, Harry W. McKimney, Instructor in Cabinet Work, Oklahoma City High School; Secretary-Treasurer, Hugh Norris, Director Manual Arts, Oklahoma East Central State Normal. H. F. Rusch, Director Manual Training, Oklahoma City, and N. O. Horning, Director of Manual Training, Tulsa, were elected members of the council.

The problems placed before the Division for the coming year are: (1) A survey of the shop equipment of the high schools of the state and recom-

Manual Training Magazine

DECEMBER, 1921

THE BOY'S COURSE OR THE TEACHER'S COURSE?

FRANK W. CHENEY

Supervisor of Industrial Arts, Long Beach, California

With the following article came a letter from the author which adds to the significance of his statements. From this letter the following is quoted:

"I have been out in the Philippine Islands for the last twelve years, the last five as superintendent of the Manila Trade School. Previous to going to the Islands I taught manual training for four years in New York State and five years in Pennsylvania. To sum it all up, I have been connected with school industrial work for twenty-three school years and have participated in the evolution of manual training from the time when it was a doubtful experiment.

"I took my shop training under a teacher of the old school, who drilled us in the good old-fashioned joints. I hated him and them at the time, but have since learned to respect both the lessons and the man. I have recently returned to the United States after a long absence and have spent a large part of my time during the past year in visiting schools, reading up, and, in general, getting caught up in my subject. The conviction has gradually been forced upon me that in the furor of bringing school work up to date, manual training as applied to the woodworker's trade, has 'o'er-leaped itself and fallen on the other side.' The lessons, which maturer judgment has taught me were the best, have almost entirely disappeared and nothing of equal value is being offered as a substitute.

"There is probably no better locality in the United States than this one in which to obtain, by first-hand talks with students, a general idea of what is going on in educational work thruout the Union. Southern California draws its population from all over the country and new students are coming in all the time.

"Boys coming here from other schools seem to have had a wide variety of experiences in manual training. Occasionally we find one who has had a good grounding in the fundamentals, but, as a rule, they seem to take it for granted that the shop is a place where they can make whatever they want to.

"I have introduced a few changes tending toward a modification of the old system and featuring education rather than production. A majority of my teachers are enthusiastic about the plan and agree that the 'speed limit' has been exceeded."

—THE EDITORS.

MANUAL TRAINING, as first introduced in American schools was almost as dry and dusty a subject as arithmetic. Woodworking appealed to our forefathers on account of its cheapness and practicability and for the same reasons it has drawn a majority vote ever since. Manual training thirty years ago was taught solely by abstract exercises and many joints survived in the school-shop for years after they had disappeared from practical use. As time went on younger and more imaginative men replaced the hard-headed carpenters who had started the work. Possessing some of the spirit of their pupils, they began to look around for a means of making the work more interesting, and discovered that there were a good many things a boy could make which involved the same lessons.

About that time "mission" furniture became a fad, and following this new impulse, the school world was flooded with text-books, each with the same miscellany of straight-line, square-cornered, shin-barking, taborets, piano benches, waste baskets, hall trees, etc. etc. There the design business seems to have stuck except that now and then somebody figures out a new species of neck-tie rack or a new system for putting a chair together.

That part of it is all right, and one thing is about as good as another if it teaches the right sort of lessons, but unfortunately the reform didn't maintain an even balance. When eminent educators started to decry the "abstract exercise," the teachers hastily fell into line, with the result that the pendulum swung to the other extreme. Where formerly they had devoted all their time to teaching correct methods they began competing with each other for "production," and annual exhibits of school-made furniture became a fixed institution.

Such a condition was much easier to bring about than to abolish or to modify; woodworking lends itself to camouflage a little easier than any other trade, and the general result has been decidedly weakening from an educational point of view.

Where a shop course was formerly laid down by the teacher in 1-2-3 order thruout the year, it is now customary for a boy to go to the shop with his own course all mapped out in his mind, entirely independent of what the teacher thinks best. His ideas seldom bear any of the ear-marks of a course of study. He wants to make some definite object and is easily satisfied with the result if allowed to have his own way.

From a superficial study of the utterances of men prominent in school industrial work it would seem that such a system is desirable. Now and then, however, we get a little "ray of sunshine" which seems to indicate that our impressions are based rather on what they *omit* to say than upon what they say. To quote more or less exactly from a recent address on "Cafeteria Education" by Arthur Dean, "Turning a boy loose in a vocational school to choose his own course of study is a good deal like turning him loose in a cafeteria; if somebody didn't guide him he'd make his whole meal of ice-cream."

In many cases the plans outlined for pre-vocational schools and manual training courses are misinterpreted. While the pre-vocational school should be a "finding-out" place, there must be a point where the boy ceases to go it blind. He may decide, for instance, after a few weeks trial, that he doesn't like the particular course in which he has enrolled. Here is the place where vocational guidance should come to the front. An injustice will be done both to the boy and to the shop if he is allowed to change

his course. When he has been made to finish what he has started; when he has held to his task, willingly or not, until he has turned failure into success, then will be a fair time to let him change, and nine times out of ten he will not want to change.

As a rule the boy's first impression will be the right one. If he chooses the machine shop as his goal it is because of a desire to make some of the intricate things that shop produces. Boy-like, he is apt to get disgusted during his first semester, but once let him get "over the hill;" once hold him down to his practice work until he is able to do some definite task efficiently, and his dislike turns to absorbing interest.

It is not the intention of the writer to stress the "trade" feature of the problem but rather to emphasize the value of teaching thoroly whatever we deem sufficiently important to include in our school curriculum. Woodworking, by an accident of birth, has led all forms of manual training to date. Of all the useful trades it has been most exploited and abused. In the drafting room, in the forge shop, in the machine shop, in the sheet-metal shop, in the print shop, in fact in every line of industrial work adapted to school use, with the exception of the woodshop, we find a sane course in the fundamentals which has remained practically unchanged thruout the years. And yet just as much time, just as much training, and just as thoro a course in headwork and handwork is required to make a master woodworker as to make a master worker in any other trade.

What we need most is a happy medium between the radical manual training of thirty years ago and the equally radical woodshop course of today. Were a boy to enter a machine shop for the first time and say, "I want to make a drill-press" it would be no more absurd than for him

to enter a woodshop and say "I want to make a chair," and yet in a large number of cases, our school woodshops are being run practically on that basis today.

Leaving out the trivial question of what the boy wants to make there are educational factors in the equation (which he wouldn't understand if he were told about them) that are of major importance. To quote from an editorial which appeared in one of our leading educational magazine several years ago:

"The chief values of manual training are in the habits, ideals, and attitudes it fosters. Systematic shopwork develops a habit of industry and observation that cannot be acquired in any other way. Work in the shop gives to the pupil a knowledge of the difference between accuracy and vagueness, and an insight into the complexity of everyday life, which, once wrought into the mind, remains there as a lifelong possession, for under a competent instructor he must do the work that is laid out, definitely right or definitely wrong."

Probably ninety-five per cent of the present generation of boys in our elementary schools are getting their manual training in the form of woodshop. Possibly two or three out of each hundred will follow the woodworker's trade when they leave school. The balance are destined to become the doctors, lawyers, merchants, richmen, poormen, etc. that go to make up the rank and file of our body politic. If Johnny, at the age of fourteen is taught to distinguish between a good job and a bad one, between fit and misfit, between straight and crooked; if he is taught that invaluable lesson so few boys learn nowadays, of finishing what he starts; if he is held to a definite objective until he achieves success; then his manual training will have put something of real value into his life. If he is allowed to "hobo" his way thru his

industrial work he will emerge at the end with a few manual training "doodads" to clutter up his house and a superficial knowledge of the subject that will be a liability rather than an asset.

In the term "vocational guidance" all the kick is in the second word. Many a schoolman interprets the guidance business as merely arranging a boy's pro-

gram so as to give him what his boyish fancy dictates. Many a boy fiddles along thru pre-vocational school, trying his luck in so many different shops that none of them gets a fair trial. The net result is an over-supply of peanut-venders, truck-drivers, and soda-fountain experts, and a shortage of skilled artisans.

FOREMANSHIP TRAINING IN THE LUMBER INDUSTRY

GEORGE HENRY JENSEN

State Supervisor of Trade and Industrial Education
Olympia, Washington

FOREMANSHIP training in the lumber industry and in other industries as well, is a very recent departure, having been started during the last few years. In the opinion of the writer, this is in reality a tardy recognition of the real part which the foreman plays in industry. In the past, this "top sergeant" in industry has been left to his own devices for real training and growth in his job as foreman. At least this has been the case so far as specific training or means of growth that had been provided by the management, until the advent of foremanship training. This recognition of the part that the foreman plays in industry is based on the fact (no longer a theory) that the foreman is not merely a gang boss working for wages and thinking only of his pay, but the very vital link between management and men. Strange as it may seem, foremanship training has been one of the later developments in connection with personnel work, even though it really forms the foundation, and paves the way for various phases of employment management and personnel work, in addition to better equipping the foreman for his job. There is much conclusive evidence available which would indicate that foremanship training should precede every form or

modification of employment management, employee representation, etc., in their various applications.

The average foreman has secured his training in a kind of "fit and try" way. He is a sort of graduate of the school of "hard knocks," and has usually learned the work from the ground up; which, of course, is as it should be, since he needs intimate acquaintance with the work which he directs and supervises. This often results in giving him too much the point of view of the men, and he does not readily appreciate the point of view of the management; which, however, as a rule, is not the foreman's fault, because the employer too often has taken no real steps to broaden the view point of the "top sergeant".

When a man first becomes a foreman he does not always understand the reasons back of orders, directions and instructions which are given him. In his effort to make good it is only natural that he should follow these instructions blindly, for fear that he might be misunderstood if he really tried to discover the reasons back of them, and even here it may be pointed out that the old "hard boiled" method of giving orders still prevails more than it should, the theory being that you can get the best results by hav-

ing the men afraid of you, or afraid of losing their jobs.

TWO METHODS OF FOREMANSHIP TRAINING

In general, two methods have been employed in connection with foremanship training work. One in the informational or lecture method, where the foremen are brought together and someone talks to them. The lecturer is usually, altho not always, an individual brought in from the outside. This method has much to commend it where the foreman has already had considerable training of developmental nature.

The second method is the discussion or developmental method where the leader of the group, specially trained in phases of personnel work, leads the discussion in which all of the foremen in the group participate; because in this work one of the first steps is to get the foremen individually thinking of their particular jobs and analyzing the various details that go to make up their responsibilities. The advantage of doing this with a group of men instead of working with them one at a time is that they soon discover that the maximum production of the entire plant is dependent not only on the efficient working of their own departments, but on co-operation and team work with the foremen of all of the other departments in the plant.

Foremanship training has been recognized by the Federal Board for Vocational Education as one of the phases of trade and industrial education. Some states have already included foremanship training in the list of activities that go to make up their state program for vocational education. In the State of Washington this work is being done by the state supervisor of trade and industrial education, and one such course has been put on at the Fisher Flouring Mills in Seattle.

SUBJECT-MATTER

The subject-matter in general, as in the case of methods, is of two rather distinct types: One, that of foremanship, which has in mind the development of a foreman to better perform the duties that have to do with his responsibilities as a foreman.

The other type of content includes work in mathematics, drawing and even machine work, primarily for the purpose of making the foreman a better workman. This latter type of content would indicate that there are foremen who have not come up from the ranks or if they have, they failed to master the details of the department in question. It is with the first type of subject-matter here discussed that this article intends to deal.

RESULTS

Some of the definite results that have been secured by plants that have conducted organized work in foremanship training include the following: Increased quantity of production; development of better production methods; better quality of production; better training of green workers; personal development on the part of the foremen; improved morale; decreased turnover of labor; fewer industrial accidents; better cooperation thruout the plant; better personal relations between the foremen and the men.

COURSE FOR A GIVEN PLANT

In order to develop a course for a given plant a careful study of the condition and needs should be made, in order that the course may be of most value to both foremen and management. In this preliminary study, the foremen should be consulted, both as to time and place of meeting, as well as content of the course, and then given an opportunity of expressing themselves as to whether or not they are in favor of having

such a course. Compulsory attendance on these classes is never satisfactory.

A CONCRETE EXAMPLE

It was the writer's privilege during August of last year to conduct such a course in the Bellingham plants of the Bloedel Donovan Lumber Company. The content of the course was first arranged with the approval of the industrial engineer and the general superintendent. The general superintendent also arranged for conferences of the writer with the foremen and the plant superintendents. Their unanimous approval was secured before the course was definitely announced.

This course was planned as a part of the general plan of the shop committee's plan of employee representation. The meetings were held on company time for an hour daily at each plant, but at the end of the first week it was discovered that due to certain rush orders prevailing in both mills only three meetings weekly could be held. However, the men requested that the meetings lost in this way be made up on their own time outside of working hours. These extra meetings were held directly after closing time.

The general "lay-out" of the course was as follows: Supervision of material; supervision of equipment, processes and operations; cost elements of equipment, processes and operations; management of equipment, processes and operations; supervision of the man factor; cost element of the man factor; management of the man factor. Each meeting was carefully planned in detail and carried on by means of discussion blanks. At the conclusion of each session printed matter was handed out to the men. This printed matter pertained to the meeting in question. In order to emphasize the points brought out in the discussion,

questionnaires accompanied this text material for the men to fill out as a result of their class discussion, followed by study and reflection later. As a matter of fact, the men were not requested to fill out the blanks, but were told that to do so would aid them in a better mastery of the subjects under discussion. This was all that was necessary. The men filled out the blanks, even though they confided to the leader of the group that it sometimes kept them going until midnight.

Superintendent Flynn, in an article for the *Industrial Harmonizer*, the official organ of the employees of the Bloedel Donovan Lumber Mills, said in part as follows: "The foremen in these two groups are studying their jobs, i. e., taking them apart and looking at them as a whole instead of from their personal or individual standpoints, in order to improve their work. Those who have served on the shop committees can appreciate this better than anyone else, because we have all come to realize that when we look at a matter from a personal standpoint we are not always doing the thing which is best for the men as a whole The instructor simply acts as the leader of the group in studying and analyzing the foreman's job with a view to making a better business team of the entire organization.

"Speaking of teamwork, I am sure that you will agree that a chain is only as strong as its weakest link. Following one of the meetings of the foreman training group this formula was found on the bulletin board: 'Good Management plus Efficient Methods plus Good Men plus Good Supervision equals Good Business Team.' Each and everyone has a place in this formula, and if all of us individually and collectively do our share there is no question but that we shall have a business team second to none."

CONCLUSIONS REACHED IN TRADE-SCHOOL WORK

GEORGE A. WILLOUGHBY

Supervising Engineer, Arthur Hill Trade School, Saginaw, Mich.

THE organizing of shopwork in a trade or vocational school in a manner to enable the various departments to work in co-operation with each other and to give practical work in a logical manner is a problem of no little difficulty, requiring a great amount of study and planning. It is the most difficult task encountered in a school giving vocational work and has been thus far only partially solved. The two big questions involved are: What work should be given? And what teachers can give it?

The selection of subject-matter is difficult because: (a) the vocational course must be specific; (b) only correlated work should be given; (c) the work must be practical; (d) exercise work should be very limited; and (e) the student must actually do the work himself.

Definite outlines in vocational work are practically impossible due to the ever changing demands and conditions in the various industrial enterprises.

The vocational teacher problem is a big one because: (a) practical work must be taught and few teachers are practical; (b) trade experience is necessary and few teachers have had it; (c) tradesmen are, in general, poor teachers; (d) tradesmen are poor organizers; and (e) some tradesmen are hard to get along with.

These last few statements may seem doubtful but I believe that most tradesmen find teaching difficult and take very little interest in doing anything but the actual instructing of their trade. They do not usually care about theoretical work, class organization, making out reports, teaching problems, etc. and many of them become discouraged easily and disregard any suggestions offered them.

Having encountered these problems in my work in a vocational school during

the past few years, I have reached certain conclusions which I think will hold in many cases:

(1) Work given in trade school courses should be almost entirely on complete projects.

(2) The work on each project should be divided into certain parts, or jobs, to be given in a logical order.

(3) Exercise work should be given only when it is followed directly by the practical application on a finished product.

(4) Average high school teachers are poor trade school teachers.

(5) Technically trained men with some trade experience and teacher training are quite successful if under direct supervision.

(6) Tradesmen under direct supervision are good.

(7) Tradesmen with teacher training under supervision are very good.

(8) Technically trained men with trade experience are very good.

(9) Technically trained men with trade experience and teacher training are best.

(10) Supervisors must be technically trained, have broad experience and have teacher training or teaching experience.

(1) Work given in trade school courses should be almost entirely on complete projects because complete projects form a basis for working out practical operations and processes and serve as a means of connecting the different departments of a school in a practical, co-operative, industrial, interesting manner. The questions arising in this regard are: Should projects be large or small? And should the students work individually or in groups? In my estimation it is advisable to have the projects small and numerous and to have each student do all of the work himself. It is possible, how-

ever, in some cases to have group projects, but never until small, fundamental projects have been completed by each member of the group. As an example, let us consider the machine shop work given during a three-year course. Suppose we select a lathe as a project, a lathe that can be used in the shop after it is completed. One boy is given one part of the work, another a second part, another still another part until all are given a job. Then, if exercises leading up to the particular jobs are given to each boy until he becomes skilled enough to finish the lathe part, he has, upon this completion, learned certain practical machine shop operations. He is then given another part and the same process is followed until all of the parts have been finished by the group. These parts are then brought together and assembled. If all has been done correctly, the boys have a finished product for the school, but the completing of this lathe may have required two or three years and perhaps some of the boys who started or finished some of the parts are no longer in school. No one of the boys helping to complete the work has had a chance to do all of the operations required for all of the parts. The work has probably been somewhat interesting but no two boys have been working on the same part and there has been no way of comparing the ability of the individual members of the group. This is perhaps a somewhat exaggerated case. Now let us suppose that we select a small bench lathe, as simple as possible, and require each member of the class to complete one. (The bench lathe may be made to suit the needs of the boy himself in a small shop of his own.) All members start on the same job and as soon as they have finished one part they go to the next, and so on until all of the parts are completed, and finally, when each individual member attempts to assemble

his completed lathe, he learns the real value of accurate and neat work if it goes together nicely and looks like a commercial product, and the troubles encountered by a poor workman if it doesn't. From the start interest has been running high because each boy is able to compare himself with his fellow workers and a boy does not usually like to have any other member of the class "show him up." Now if preceding and following this particular project we have others bringing out other important machine operations from the simplest to the most complicated and have made the correlated work to conform with the requirements of the projects we have established a machine shop course composed of several finished "races" of the most interesting type and when all have been finished we have a young machinist with some of his own shop equipment.

Other valuable projects are a bench anvil, a bench grinder, a bench drillpress, a V-block, a thread gage, a surface gage, and a small gasoline engine.

In a similar manner the work in the drafting department may consist of the complete sets of drawings of these same projects, the work in the pattern shop the making of complete sets of patterns, and the work in the foundry the making of complete sets of castings, and with close co-operation under the supervision of one man all of the departments can be made to operate in such a way that each contributes its share in the production of finished products.

(2) Obviously, certain parts are more complicated than others, and involve more advanced work than others which must be given only when the previous operations have been such that they lead from the simple to the more complicated. Thus it is necessary that each project be divided up into certain parts or jobs in such a way that the work can be given

in a logical manner. For example, chipping and filing the anvil may be given as the first job, drilling and filing the hole in it as the second job, smoothing and polishing as the third job, and enameling the fourth job. The bench grinder project may be divided into jobs covering the completing of the individual parts such as grinder T-rest, T-rest bracket, angle rest, angle rest bracket, etc. Then it is possible to give these individual jobs at a time when they are needed for bringing out certain machine operations or processes.

(3) Sometimes, in our process of manufacture, we find that we have no job bringing out some important operation, or we have some work of a new type to be done on a large piece of expensive material upon which considerable work has already been done. In such cases it is necessary to give exercise work on a small piece of material or in the best possible manner. For example, the spindle of the grinder requires threading which is a rather difficult operation for the beginner. The shaft is a large piece of expensive steel and there is considerable turning work required before the threading can be done. It is advisable to give the student a piece of cast iron or a small piece of steel and have him practice on this and other pieces until he is able to cut threads accurately, at which time he can be given the job of cutting the threads on the spindle. In electrical work it is necessary to give a great deal of exercise work because of the many necessary jobs that cannot be given on practical projects.

(4) Average high school teachers are poor trade school teachers because their training and experience have been of a different type from that required in a trade school. I do not mean to imply that no high school teacher can become a successful trade school teacher, but he

must have had in addition to his college or normal training a training in, or close connection with, industrial and commercial enterprises, and he must be able to appreciate the type of student he is teaching. Trade school students are, in general, of a different type from those found in high schools. Academic work is usually more or less difficult for them.

(5) Technically trained men with some trade experience and teacher training are quite successful when under direct supervision, if they are able to grasp the practical idea of their work. They have a good foundation upon which to build; they are not set in their ways; and with the assistance of experienced supervision they will develop if they have a desire, and spend their time outside of school in pursuing their line of work. Careful observation and study will also be of assistance to them.

(6) Tradesmen under direct supervision are good, provided their work has not been too limited. An "experienced" foundryman may have had five years' experience setting up the same mold in the same foundry. The right kind of a tradesman, however, will carry on his work if he has someone to assist him in picking out the right kind of work and arranging it.

(7) Tradesmen with teacher training, provided they are the right kind, will be able to carry on their work without so much assistance.

(8) Technically trained men with trade experience are very good, if they have assistance in methods of teaching, because of their ability to grasp new ideas and to keep up with the times.

(9) Technically trained men with trade experience and teacher training are best, because of their ability to grasp new ideas and to promote the work under their supervision.

(10) Supervisors must be technically

trained, have broad experience and have teacher training or teaching experience. They must be technically trained to be able to promote the work under their supervision in the most intelligent manner. They must be experienced in order

to demand the respect of those working for them. And they must understand thoroly the principles of teaching in order that they may assist those under their supervision if necessary and arrange their work correctly.



FIG. 1. FRANCIS SCOTT KEY SCHOOL, BALTIMORE, MD.

PLANNING A SCHOOL TO FIT EXCEPTIONAL CONDITIONS

CHARLES A. BENNETT

NOW that the report of the Study of the Francis Scott Key School has been published,¹ it may be of interest to some of the readers of this *Magazine* to learn the outcome of the study. Those who have not read the report may wish to know a few of the main facts concerning it and the conclusions reached.

In the first place it should be stated that this study was made because the former school building had been burned and a new one had to be constructed. It was made at the request of the Parent-Teachers Association of the school acting thru Mrs. William Bauernschmidt and inspired by Miss Persis K. Miller, principal of the school. As a matter of fact,

¹ Bulletin, 1920, No. 14, U. S. Bureau of Education, Washington, D. C. The Francis Scott Key School, Locust Point, Baltimore, Maryland, by Charles A. Bennett.

the study was made because Miss Miller realized that the customary elementary school was too stereotyped and too limited in its scope to meet the particular educational needs of Locust Point in the highest degree. She therefore shaped conditions which made the study possible.

The month of March, 1920, I was in Baltimore studying the school, the industries, and the community at Locust Point. For the benefit of those who are not familiar with the map of Baltimore, it should be stated that Locust Point is the lower end of the city. It is almost surrounded by water. At the end of the Point is the U. S. Army Hospital Fort McHenry, the site of the civil war fort by the same name. Many industries are located along the water front, the largest of these being the Baltimore

Dry Dock and Shipbuilding Co. In the central part of the Point are residences, built for the most part in solid rows, a few small stores, two or three churches, a fire engine house, a public library, and one small recreation center and resting spot, Lathobe Park. Most of the unused land is a dumping ground for surplus dirt, brick bats, etc. The smoke of the big factories, the din of the riveting hammers, the rattling of freight cars and the screeches of the engines gives "local color" to the place. The child's environment, except for Lathobe Park, is made up of rather narrow streets and a sea of tin cans and dump heaps surrounded by high board fences. If there ever was a place where children ought to be under school supervision more than the usual number of hours per day, here seemed to be the place.

As I gathered facts concerning school conditions, the first to impress me was that only about one-half of one per cent of the children of Locust Point ever go to the high school, and yet the school at the Point was like others in the city, in that its curriculum was planned with reference to fitting children for the high school. The second fact, and the usual corollary of the first one, was that a large proportion of the children, both boys and girls, were quitting school and going to work as soon as the law would permit them to do so. The data collected showed that during the two years just previous to the study, the average drop of students between the fifth and sixth grades was 46.5 per cent, from the fifth to the seventh grades 71.8 per cent and from the fifth to the eighth 79.3 per cent. Of the children left in the school, quite a large number were over age.

In the factories (and I visited most of them) the work-certificate children held jobs in which there was very little chance to learn a trade or to work up beyond a

PROPOSED SHOP BUILDING
SCHOOL #76, BALTIMORE

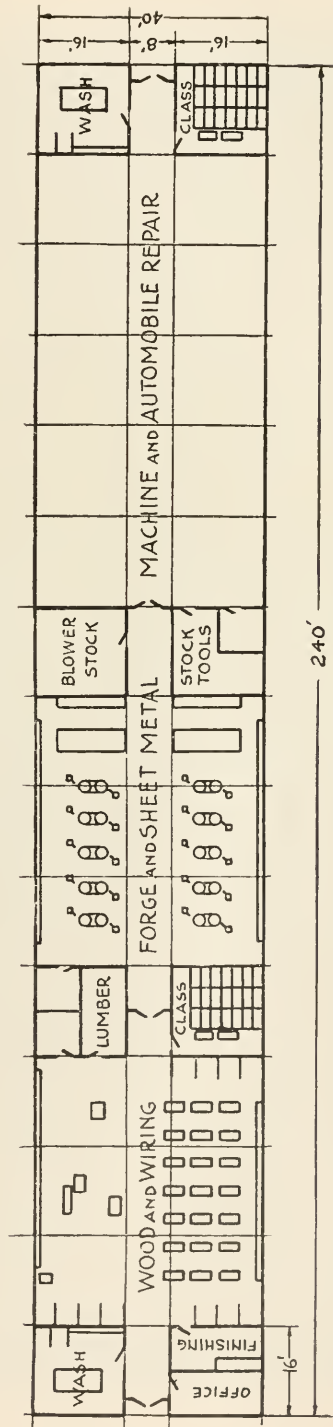
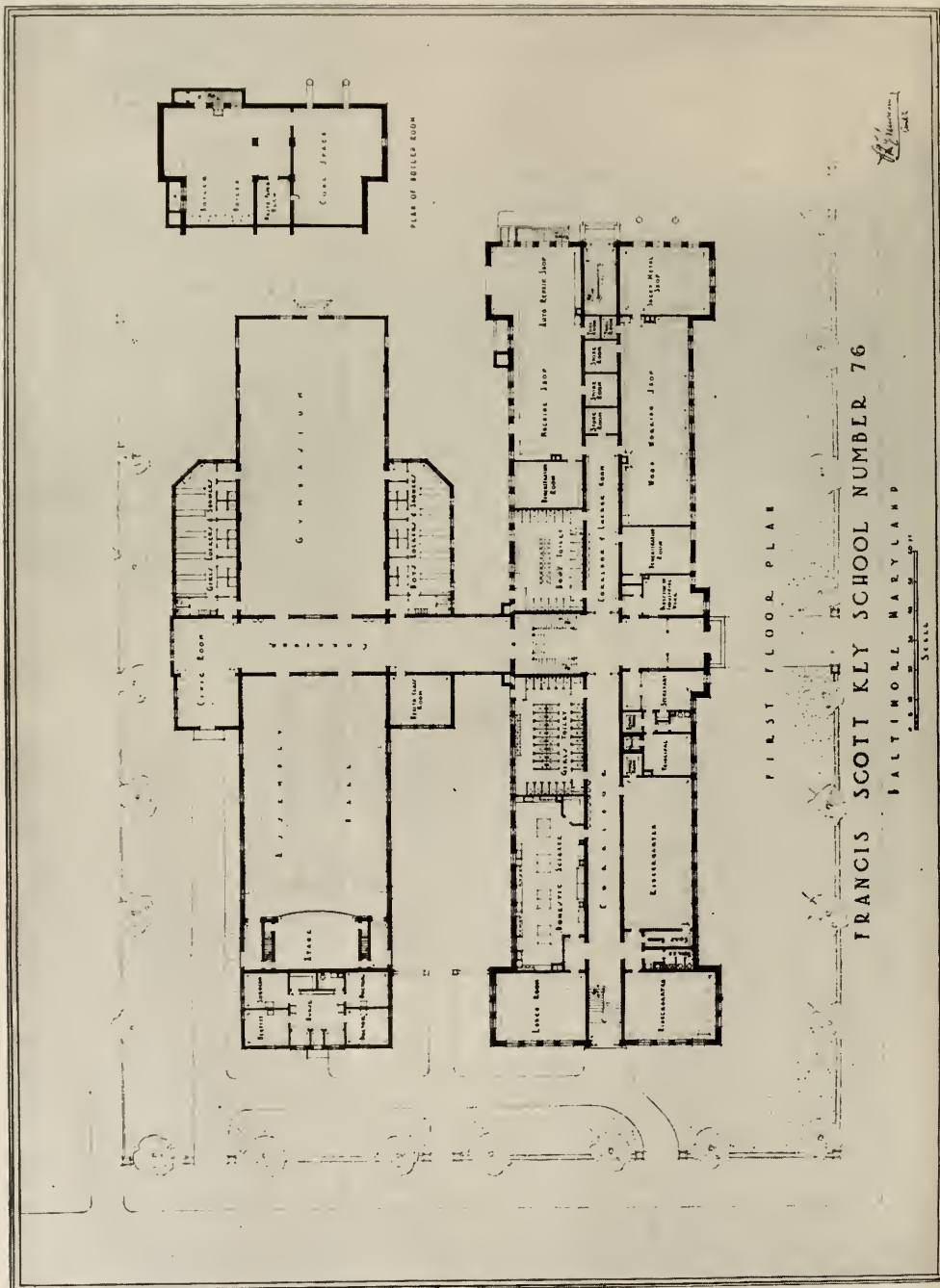

Fig. 2.



FIRST FLOOR PLAN

FRANCIS SCOTT KLY SCHOOL NUMBER 76

BALTIMORE, MARYLAND

W. H. ...
1925

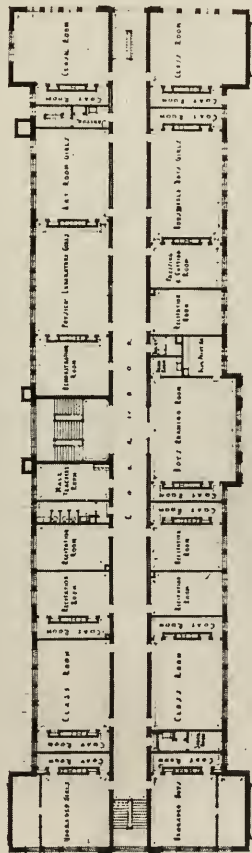

THIRD FLOOR PLAN

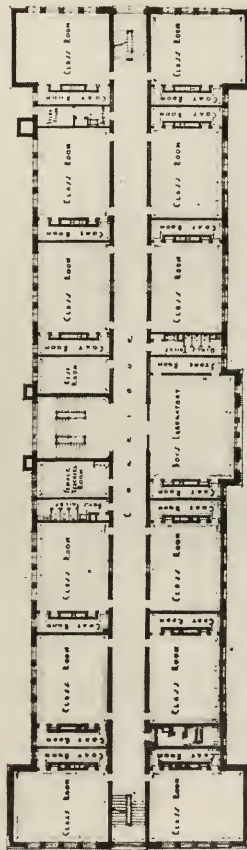

SECOND FLOOR PLAN

FRANCIS SCOTT KEY SCHOOL NUMBER 76

BALTIMORE, MARYLAND

1917

H. Schuman
Arch.

FIG. 4.

mere routine job. They were carrying things from one place to another—bottles from a machine to a furnace, or from a furnace to a box, blocks of wood from a saw to a truck, boards from a pile to a man at the saw, or making bundles of paper bags. Once in a while one was found running a punch press or some other simple machine.

While it is possible that such occupations may contribute to the making of self-supporting "Americanized" citizens, one would surely prefer the occupations of a first class modern school. It is possible that the lessons forced upon boys and girls of fourteen years of age in these industries may, in a few cases, be more valuable than school experience, but in most cases this is not probable. Certainly, if the school is living up to its possibility, it can do far more for children under sixteen than such industries.

With this point of view the following changes were recommended:—

1. Place all children 13 years of age or older, except a few of the 'ungraded,' and all others who have reached the sixth grade, into a division of the school to be run under a departmental organization and having a curriculum in which industrial training and the right kind of physical training and recreation are given an equal place with other subjects. This might be called an intermediate school.

2. Organize co-operative part-time classes for such students as must leave school and go to work before graduation from the intermediate school.

3. Provide a one-year trade or vocational course following the eighth grade.

With these three established, facilities would also be provided for—

4. More industrial work for slow and subnormal students who are now classified as 'ungraded.'

5. Evening trade or vocational classes for young men and young women who are working in the industries and are desirous of improving their education."

A careful estimate of the probable number of students available for each grade and section under the proposed plan was then made, a working timetable of classes prepared and a list made

of the teachers that would be needed in the modified school. From this data the number of rooms in the new building and the use of each was determined. The names of the rooms given in the following list will indicate the character of the building proposed:

A. Rooms Needed for Division of the School under Classroom Organization—The Elementary School

- Two kindergarten rooms.
- Three classrooms for Grade I.
- Three classrooms for Grade II.
- Three classrooms for Grade III.
- Three classrooms for Grade IV.
- Two classrooms for Grade V.
- One classroom for ungraded boys.
- One classroom for ungraded girls.
- One open-air classroom.
- Two playrooms.

B. Rooms Needed for Division of the School under Departmental Organization—The Intermediate School.

- Four study and recitation rooms for 20 pupils each.
- One physical laboratory for 20 boys.
- One physical laboratory for 20 girls.
- Two demonstration rooms each for 20 students.
- One drawing-room for 20 boys.
- One blue-print room.
- One art room for 20 girls.
- One workroom for 20 girls in household art.
- One fitting room.
- One laboratory for 20 girls in household science.
- One gymnasium.
- Shower baths and lockers.
- Swimming pool.
- One health classroom for 40 students.
- Three shops, each for 20 boys.

C. Rooms Needed for Use of Both Divisions of the School and for Community Use.

- One assembly hall.
- One civic room.
- Five small dispensary rooms.
- General office for the school.
- Principal's private office.

For the shops it was recommended that a simple one-story building be constructed. The floor plan is shown in Fig. 2. This was to have clear story windows above, and on the side walls an ample number of 9 ft. windows above a 5 ft. line, thus leaving good spaces for cases along the outer walls of the shops. By

combining two kinds of work (as wood-working and electrical wiring, forging and sheet-metal work, machine shop work and automobile repairing) in one room, six lines of work were to be carried on in three shops and each to have really good facilities for both kinds of work with a minimum of interference with each other. The particular lines of shopwork selected were determined after a study of the typical industries on the Point. Probably forging represents the largest number of industrial workers, machine shop the next, then sheet-metal wood-working and electric wiring. Automobile repair was added, not because it represented any particular industry on the Point, but because of its very general application and the opportunity it affords of gaining useful mechanical experience.

The report was taken to Otto G. Simonson, the architect employed by the Board of Education, and he designed the building shown in the accompanying illustrations, Fig. 1, 3, 4. It will be seen that in only two particulars did he essentially modify the plan. He omitted the swimming pool and changed the scheme for the shops. Being too limited in his

appropriation of funds for the building and in the size of the lot upon which to place the building, he was forced to place the shops inside the main structure and to very materially reduce their size.

This story of the Francis Scott Key School is told in this very brief manner to call attention to the efforts of a progressive school principal and parent-teachers association to break away from the traditional idea that all schools of grammar grade in the same city must be alike in curriculum and aim. The planning of this school was clearly an effort to show how an individual community—in this case an industrial community—may have its school facilities adapted to its particular needs without departing from the fundamentals of American elementary education, and how in doing so it may provide facilities for industrial education, training in home economics, part-time schooling and a rich program of evening school courses for adults. To all these it may add exceptional facilities for recreation, health education and the prevention and treatment of disease in so far as that should be undertaken in a community dispensary.



TOY-MAKING FOR HANDICAPPED CHILDREN

MICHAEL C. DANK

Instructor in Manual Arts, Brooklyn, N. Y.

THE problem of providing a suitable form of manual training (handwork) for feeble-minded, crippled and anemic children has given educators much food for thought and has been met in various ways by our own institutions for elementary instruction, and by those in other countries.

Because of their physical and mental deficiencies, these children are unable to undertake the regular academic and manual training work prescribed for the normal child. Special equipment and methods of instruction must therefore be provided, and especially trained teachers are required to give them this training.

Educational history has confirmed the fact that the intellectual growth of the normal child is to a great extent dependent upon the development of its muscular powers. This is especially true of the sub-normal children who come under any of the three groups of defective children mentioned above. Instruction in handwork plays an important part in the education of these children. The real problem lies in the selection of suitable forms of handwork that will react most beneficially in developing their organs of sense and muscular activity. This development is essential to their welfare in that it creates a foundation for such further training as will make them independent and useful members of society.

There are indeed many kinds of handwork that can be given such children with great advantage. Basket and raffia work, clay-modelling, paper-cutting, drawing and coloring, and especially for girls, sewing, knitting, and artificial flower making. All these branches of handwork possess many qualities of merit

and a wealth of educational value for the handicapped child.

But there is still another form of handwork which is steadily gaining headway and becoming recognized as an ideal manual art for the training of children of this class, i. e., toy-making. The writer, who regularly conducts classes in shopwork in the seventh and eighth grades of a typical large city school, has recently given instruction in toy-making to crippled and later to feeble-minded children in the same school. The results obtained may be of interest to all teachers in charge of similar classes of handicapped and defective children in solving the problem of offering them a form of handwork that is not only beneficial, but also of greatest interest and delight.

The work was first given to a class consisting of crippled children, both boys and girls. It was started at the suggestion of these unfortunate "kiddies" themselves, who, because of their deficiencies, were unable to take the prescribed school course in the workshop. Repeatedly they would ask to be permitted to go to the school shop to make all those "nice things" which the "regular boys" made.

The problem at hand then was to give some form of woodwork to these crippled children who were unable to work in the school shop and had never before received any such instruction. The possibility of giving them a course in toy-making in their own classrooms seemed feasible in meeting their appeal.

An arrangement was soon made for beginning this work. A class was formed consisting of boys and girls over eight years and able to use the few necessary simple woodworking tools. The regular teacher in charge of the class

promised her assistance during the first few introductory lessons and to continue the work herself thruout the remainder of the term as a regular part of her class-work.

The problem of providing the necessary toy-making supplies and equipment came up and was easily solved. Each child

On the appointed day all necessary materials were given out. A short introductory talk followed concerning the many possibilities of the work, and some of the interesting toy models that would be made. The little cripples were very enthusiastic over this new experience and eagerly awaited the signal to begin work.



CLASS OF CRIPPLED CHILDREN MAKING TOYS, PUBLIC SCHOOL No. 150, BROOKLYN, N. Y.

was given a large envelope which contained a pencil, crayons, a coping saw, ruler and a sheet of carbon paper for tracing. The other supplies were kept in a closet and consisted of a few brad awls and hammers, a saw-board and clamp for each desk, and a small stock of cotter pins, sandpaper, $\frac{1}{2}$ " brads, and $\frac{3}{16}$ " basswood blanks. The saw-boards were made by the 8A shop boys as a regular class problem. Incidentally it is worthy of note that one of the great advantages in teaching toy-making is the comparatively small cost of equipment.

A demonstration was then given as to the manner of clamping the saw-board to the desk top, the method of tracing the patterns to the wood, and how to use the saw. The children worked from full-sized patterns which they traced to the wood and cut out with the coping saw. The models made at the start were simple in character and of interest to both the boys and the girls. Some of these were birds, animals, and simple mechanical moving toys. Many of the children, whose arms were partially paralyzed, found considerable difficulty at first in handling the coping saw. But, as the

work progressed, thru patience and perseverance, they showed remarkable improvement and seemed to gain more vitality in the muscles of their hands and arms.

The interest of the children increased with the introduction of new and larger models. Before long, the boys were making aeroplanes, boats, prize fighters, derricks, jumping clowns, and other attractive models. Naturally, the girls chose to make dolls, doll furniture, such as chairs, rockers, beds and cradles, and a variety of household novelties, such as plant sticks, calender backs, match strikes, etc.

By the end of the term a wonderful collection of toys, neatly colored in attractive crayon colors and shellacked, had accumulated. The principal of the school was delighted with the results obtained by these children, and arranged to have their toys on exhibit before the rest of the school.

It is perhaps worth relating that on pleasant days the lesson in toy-making was given outdoors in the school courtyard. At such times, the class furniture, desk and seat, which are necessarily removable, was placed out in the open and the children were then ready for an enjoyable and healthful session. The benefit of outdoor work of this nature for crippled and especially anemic children can readily be seen.

About the middle of the term, while the crippled children were making splendid progress in their toy-making activities, the writer began similar work with a class of feeble-minded children in the same school. The latter presented quite a different kind of problem. Most of them possessed a very low degree of mental power and capability of understanding. They are at all times subject to varying moods and at times there is much difficulty in gaining their attention.

Their manner of speech and bodily movements were also noticeably awkward.

Bearing all these facts and conditions in mind, preparations were made to teach these feeble-minded children the fascinating art of toy-making. Similar equipment and materials were provided them as for the crippled children and somewhat the same introductory methods of presenting the work were given. It was difficult for these children to even understand and follow directions carefully. Naturally the models first given were simpler in character, and a policy of repetition of all old and new steps was resorted to as the work progressed.

It was truly a pleasing experience to watch these pitiful children busily and happily at work, transforming the raw wood blanks and cigar boxes gathered by themselves, into a large number and variety of splendid toys and novelties. To the surprise of the writer, the quality of their workmanship ranked higher than that of many a normal child. They seemed to exert a greater effort to obtain a first-class product. Their work was indeed an expression of their very best efforts. The capable manner in which they used their tools, as exemplified in the finished product of their work, was really remarkable. One wondered that such good work was possible by children of their low mentality.

So gratifying and successful were the results obtained from the toy-making activities held in the classes for feeble-minded and crippled children, described above, that all the teachers in charge of these classes are giving work in toy-making this term. And when teachers of defective children in other schools learned of this work, they also began similar instruction in toy-making for their classes. A class of anemic children conducted in the same school is also beginning the delightful craft of making

toys and novelties in wood. They are highly enthusiastic over the work and are deriving much fun and entertainment of a healthful and wholesome nature. The exercises in sawing and hammering are proving very beneficial in strengthening their weak and undeveloped muscles.

It is hoped that the experiences given above will prove of some value to those teachers who are in charge of classes of defective children of the type discussed in this article: Considering the small

expense involved for necessary equipment, and the facility with which the work can be adapted to all kinds of conditions, the art of toy-making, as one branch of manual training, should play a more prominent part in the education of defective children. Surely its further introduction into the schools and other institutions where such children are found will go a long way to stimulate and sustain their interest in school work, and help to build up their physical and mental powers.



A GOOD BIT OF SCHOOL ADVERTISING FROM THE SCHOOL OF INDUSTRIAL ART, TRENTON, N. J.

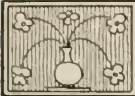

EDITORIAL REVIEW FOR THE MONTH

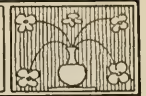

ARMISTICE DAY

ALL in the usual course of events it comes about that on Armistice Day the Editor sits down to write this column. He has just heard the speaker of the day at the Rotary Club relate heart-burning experiences behind the front line trenches in France, and in another hour or two he will witness the unveiling of a beautiful tablet erected in honor of the men who fought to free the earth from a militaristic tyrant. This evening he will read the newspaper account of the first steps in organizing what the nations of the earth profoundly hope may prove to be the greatest event in human history since the Sermon on the Mount. It, therefore, seems impossible to write anything this afternoon that does not at least reflect the thoughts inspired by the main theme of this great day. To write on the usual topics of our profession in the usual manner is impossible on such a day. When one is fired with the vision of the Golden Rule being applied to the affairs of nations as Christianity has applied it, in considerable measure, at least, to dealings between individuals, other problems fade into significance. On this day we seem to stand at the turning in the highway of civilization. Before us the possible goal of peace on earth, good will among nations; behind us is the War with its lesson which must not be forgotten. In the words of Chi Gamble, Peoria's poet of the day,

Three years ago the big guns worked—then halted;

Three years ago the rifles spoke—then stilled;

Three years ago the Right was high exalted;

The war was ended as our Nation willed.

Three years ago we pledged our faith and station;

Three years ago we owed our men a debt;

Three years ago we promised God and Nation

Our best. God help, lest, foolish, we forget!

SPIRITUAL RESOURCES

THE thoughts of Armistice Day suggest the statement of a preacher of righteousness and human brotherhood that "the spirit is beginning to campaign against substance." We hope it began to do this a very long time ago, but surely it is becoming more evident, let us believe, at the present time. There are certainly many hopeful signs. A good example is found in business. Witness the remarkable special letter sent out by Rodger W. Babson on the 25th of October entitled, "Spiritual Values in Industry." Here is part of it:

The old method of teaching economics was that everything comes from "land and labor." Many courses are now being taught in our colleges today along those lines. Statistics, however, clearly show that this is a fallacy. For instance, China has greater natural resources and more available labor than this country and yet it is away behind this country. *Natural resources, available labor, and capital are important, but those things are of little value until they are released by people filled with the spirit of God. This is what the study of economic history clearly teaches.*

It is very important for clients to see that their sons and daughters realize that the old system of economics is false because it omits the most important factor of all, namely, the spiritual values. As Towson says, "Materials, labor, plants, markets, all these things can be adjusted, but the soul of man, which determines his purposes and his motives, can only be converted thru religion."

Printing was discovered in China several thousand years ago, but it began to be developed only three or four centuries ago in Europe for the spreading of the teachings of the Bible. It was the desire to propagate the teachings of Jesus which developed printing. Religion has been the spiritual force which has developed not only our nation politically, but commercially and industrially as well. Economic history teaches one thing very plainly: the industrial problem will never be solved by employers' associations, or labor associations, or consumers' associations, but only as all get together as brothers filled with the spirit of God. If I learned

one thing during the two years when serving Secretary of Labor Wilson, in Washington, it was that these problems can never be settled by force or by legislation.

I am speaking as a statistician, not as a preacher. Our political freedom, our personal safety, our educational system, our work to relieve suffering, our industry and commerce—everything that is worth while to civilization—we owe to those spiritual qualities which teach man to serve.

value on the spiritual product and never be satisfied with mere training in skill. His aim must never be less than education in its higher meaning, which always places spiritual products highest in the scale of values. Armistice Day and the teachings of Babson should be at once a warning and an inspiration to teachers every-



DESKS MANUFACTURED IN THE SCHOOLS OF CINCINNATI.

If it is true of industry and commerce that spiritual resources transcend material resources how much more must it be true in the realm of education that fits men and women for industry and commerce!

But right here is where the champions of liberal education have made a mistake. They have reached the too hasty conclusion that industrial education is materialistic because it deals with tools and raw materials, blue-prints and salable products. The facts are that blocks of wood and castings of iron are, in themselves, no more of a hindrance to spiritual growth in students than are books and maps and science experimental apparatus and charts of the heavens. It is the use made of the materials that counts for or against the growth of the spirit in the schools of the nation. The vital thing is that the teacher shall have the spiritual vision and the spiritual goal in his teaching, that he shall always place the proper

where—in the grades and high schools as well as in vocational schools. The teachers are the channel, if not the fountain head, of spiritual resources which are also the greatest economic resources, not only of the nation, but of the whole civilized world.

SUMMER MANUFACTURING IN CINCINNATI

MORE and more school shop equipments are made use of during the summer months in the manufacturing and repair of school furniture and fixtures. This is as it should be; it is a means of conserving educational funds, and at the same time of building up the teaching strength of the schools and supplementing the practical instruction of a limited number of students who especially need the experience of a real, producing factory. A few months ago we called attention to such work in Des Moines; below is an excerpt from a report recently made to Superintendent Randall J. Condon by

Elmer W. Christy, director of industrial arts in the public schools of Cincinnati:

While we have previously undertaken similar pieces of work they have not approached in magnitude or completeness of organization our present efforts; in fact, we have practically the same kind of an organization which was developed in our war education and which received such marked commendation from the War Department, except that we use boys instead of men and work eight hours per day without taking out time for military drill or other duties.

Among the jobs undertaken this year were fifty-three flat top standard teachers' desks for the new Hoffman, Kilgour and other schools, twelve drawing-board cabinets for the East and Walnut Hills High Schools, a large number of heavy benches for the East High School, rebuilding and refinishing some ninety-six tables and six hundred and fifty chairs, and the serving counter for the Woodward lunch room, and the reclaiming of some thirty-four wood-turning lathes at Woodward which after thirteen years of use had become nearly useless. We also undertook to install electric lights in a number of the portable school buildings and succeeded in completing twenty-two rooms.

During the regular school year the program provides only from one and a half hours to three hours per day for shop work for any student and the work is therefore intermittent and non-intensive. During this period it is our aim to train in the general principles of the various trades. The purpose of the summer work was to provide for those boys who have shown themselves most apt an opportunity to apply those principles in a practical way under conditions as nearly like commercial shop conditions as we can provide in a school. The results were that they acquired not only considerable skill but a large amount of practical information concerning the branch of work in which they were engaged.

In organizing classes we employed only boys who had previously received instruction in the principles of the trade which that class represented. Co-operative students who were ready to go to work in commercial shops and for whom positions could not be found were given preference in the school shops. Their number being inadequate, we employed boys from the regular industrial arts course. The rate of pay was 20c to 25c per hour, eight hours per day.

The teachers were in all cases not only skilled in the art of teaching but practical workers in their particular trade. The work passed thru the shops in units and considerable repetition was involved. The large number of different operations to be performed however, and the shifting of the boys at frequent intervals enabled each boy to receive in-

struction in a great many more operations than he would in a commercial shop in a much longer period.

While we were organized for and worked for efficient production we did not lose sight of the educational side of the work.

We gave each teacher from eight to ten boys and this average was maintained thruout the period. In this respect our organization differed from those in some other cities where teachers only are employed to do this class of work. We can say with assurance that our product is the result of students' work.

We feel sure that the quality of the work will pass rigid inspection—in many cases be found superior to that which would have been received from commercial establishments under competitive bidding. One of the most delightful features of the summer work was the splendid attitude of both teachers and students.

In figuring costs we have included the boys' wages, teachers' salaries, cost of material, cost of supervision and services of a millwright. We have not included the cost of operating the plants nor the depreciation of equipment. The market value of products is a very uncertain quantity. In the matter of teachers desks we used the figure which the Board of Education would have paid at the time the order was placed; for the drawing board cabinets we had a bid of \$180.00 each while we figured them at \$160.00; for the new part of the serving counter at Woodward we had a bid of \$400.00 but, for additional work, raised the value of \$500.00. For the electric wiring we figured each room at \$150.00. Taking into consideration bids for similar work and the better fixtures used, this seemed reasonable. On other orders we have made estimates which we believe to be conservative.

For the summer work the final report indicates the following:

Salaries and Wages.....	\$ 6,017.22
Materials.....	4,176.65

Total.....	\$10,193.87
Value of Product.....	\$13,046.00

THE DELGADO TRADE SCHOOL IN
NEW ORLEANS

THE accompanying photograph shows the main entrance to the building of the Isaac Delgado Central Trades School of New Orleans. Much has been published concerning the gift of Mr. Delgado, of the industrial survey of the city of New Orleans, and of plans for the building of this new school, which will be the

largest for white boys in the South. The building alone has cost approximately \$685,000, and the equipment a little more than \$100,000. New Orleans is justly proud of this addition to her educational facilities.



MAIN ENTRANCE, DELGARDO TRADE SCHOOL,
NEW ORLEANS.

The selection of trades to be taught was made on the basis of the numerical strength of the various trades as shown by the Government census reports, with but one or two exceptions. The trades selected for the opening of the school are (1) carpentry, (2) cabinet making, (3) pattern making, (4) plumbing, (5) sheet-metal working, (6) machinist, (7) electricity, (8) printing (9) tailoring.

For the present the operating expenses of the school are provided very largely thru a special state tax of \$50,000 a year. When filled to capacity, 450 student, the cost will probably be double what it is at present.

The teaching staff is made up entirely of local experts in the several trades

taught. H. G. Martin is the director of the school.

DISARMAMENT PROBLEMS IN THE SCHOOLS

THE great Disarmament Conference and the facts it is bringing to the people of the nation provide a fine opportunity for the schools to teach lessons in the cost of warfare. The East Side Commercial and Manual Training High School of Newark, N. J., is making use of this opportunity by giving the following problems:

1. The total amount spent for the war by all nations was 186 billion dollars. Write this amount in figures.

2. In your opinion which of the nations if any, were better off after the war than before?

3. The war was costing U. S. Government a million dollars an hour. This is equivalent to how many dollars a minute? A year?

4. The U. S. Battleship Maryland cost with equipment \$42,000,000. The East Side High School cost about \$450,000. Draw a line $\frac{1}{16}$ " long to represent the cost of the school; on the same scale draw another line to represent the cost of the ship.

5. It takes about \$2,000,000 a year to keep the Maryland in commission, and the annual depreciation in the value of the ship is about \$4,000,000. Would \$6,000,000 be sufficient to run all the high schools of the State of New Jersey, if there are 35,000 pupils, expense per pupil averaging \$110?

6. The number of soldiers and sailors killed in the war was 12,990,570. This is how many times as large as the population of Newark, 450,000?

7. The par value of the French or the Swiss franc is 19.3 cents. Today in New York the former is worth 7 cents and the latter 18 cents. Each is how many per cent below its true value? Can you give any reason why there is so much difference between the two.

8. Ascertain from a dictionary the par value of the Dutch florin and of the German mark. Look in a newspaper under "Foreign Exchange" and find what they are worth today.

9. It is said that each family contributes an average of a dollar a day in taxes (city, state, and national) at least half of which is devoted to expenses of war. If one dollar saved each month in a Building & Loan Association amounts to \$200 in about 11 years, how much would \$.50 a day amount to?

10. From statistics in these questions or elsewhere make up for yourself, and solve, a problem illustrating the costliness or uselessness of war.

11. (Extra Credit). Would 186 billion dollar-bills, each 7 inches long, be sufficient to reach around the earth (25,000 miles) if placed end to end in a single line? How many miles long would the line be?

A SHOP RECITATION PERIOD

THE biennial report of the state superintendent of public instruction in Wisconsin contains a chapter of more than usual interest to manual training teachers. Chapter IV is entitled "The Newer Conception of Manual Arts" and is written by H. W. Schmidt, state supervisor of manual arts. In this he points to the war experiences as the cause for certain changes in manual arts instruction and especially of a change in viewpoint with reference to such instruction. The fact that shopwork lends itself so readily to "just working" leads him to warn teachers against aimless exercise with tools and to emphasize the importance of formulating aims which may determine the character of the work done. He does not claim to present any new aims, but he emphasizes the importance of having *an* aim and suggests that the foremost aim might well be "the development of industrial intelligence."

If one were to stop at this point in his reading of the report he might be much disappointed because "industrial intelligence" is such an undefined thing. It has been evident in our terminology for several years without being very much in evidence in our practice. But Mr. Schmidt goes on to tell us what he means by "industrial intelligence" and suggests how to stimulate its growth. He believes in giving the students a variety

of experiences in shopwork and in having them acquire some real skill in the use of tools. He places considerable emphasis on good technic, especially in drawing. He would like to have metalwork, cement work and electrical work added to woodworking. But, the distinctive thing that characterizes his statement is his recommendation on "assigned reading and study." He believes in devoting one period a week to the discussion of assigned topics. He says,

The special requirements for the manual arts work include a minimum of one recitation period per week to be devoted to a definite recitation or discussion of some assigned work on related subjects, special topics or problems. This hour is not to include the usual ten or fifteen minutes spent daily at the beginning of each class period in developing the main theme or process under consideration for that period. If we are to drive in the direction of industrial intelligence we must plan more emphasis upon real recitations. This means that discussions must take the place of passivity; that students themselves must take an active part in the discussions. The students must come prepared to recite or preferably to talk, and this preparation in turn necessitates assigned work, both book work and work in observation, such as visits to manufacturing plants, mills, etc.

It seems evident from this that Mr. Schmidt's observation and teaching experience have led him in common with many others, to the conclusion that the manual arts work must lead the pupil's observations, interests and thoughts out beyond the work in hand; he must be led to make intelligent connections between what he is doing and what is being done in the great world outside of the school workshop. They have also led him to the conclusion that this can be done best by assigning to such work a definite period in the weekly program.

I believe that in 20 years the working children will be required to return to the continuation school not for four hours a week but for half time. As you know, under the terms of the law, we must be content with four hours a week. We accomplish wonderful things in this short time but two weeks a month would be the very best.

—MORRIS E. SIEGEL.

A POINT OF VIEW

I SAT in my room the other night with an old and dear friend whom many of you know by face and all should know at least by name. I said to him, "Why do you read the *Manual Training Magazine*? You are not nowadays within a thousand miles of manual training work." I tossed him the last issue which I had in the room, saying, "Now, just what did you read in that issue, how did you read it, and why? Come now, 'fess up!"

He began by saying that he heard, the past summer, the following definitions in a London music hall: "A high-brow is one who is educated beyond his intelligence," and "A low-brow is one who is intelligent beyond his education."

Just why my friend started out in this sort of way I do not know, except, perhaps, to give a covering description of two extreme types of persons who might read the *Manual Training Magazine*. I certainly know that my friend falls in neither the high nor low-brow class, as his intelligence is adequate to his education, and his education fits in well with his intelligence. I pressed him for his answer to my questions, and this is the way he answered them:—

"Well, the first thing, I always look thru the contents. I see a fellow's name, and I run my finger across the page to see what he is writing on. I either know him, or have met him at some convention and have heard him speak, or else I like the topic on which he is writing. In any case, whether it is the subject or the man, I get interested and turn over to the proper page and commence reading the article. If I do not like it, I quit. If I half-way like it, I see how long it is before quitting. If I like it real well, I read it thru, tear out the pages concerned, and mail them to a friend of mine who is interested in educational things. Next, I see what you have to say, Dean; then

I look at Bawden's 'Washington Correspondence'; and then I run thru the editorial review, especially where it concerns personnel. After that, I run over the field notes. I like to read about Leonard, Jacobs, and Snyder of California; Wilson, Works, Furney of New York State; Greener, Crawford, and Broadhead of Boston—in fact, all of the fellows. I was once of them, and always will be with them. Then I look at the advertisements. I think of the first school I equipped, and how I had to sit up nights figuring out the original estimates, only to be told to cut them and recut them until one could not recognize the original request. I like to run thru the list of books mentioned, especially those which help make the teacher's work easier than in the old days and yet more efficient than in my time. I study the illustrated projects ranging from teapot stands to weathervanes and think of the boys of the present who, as of old, blow on the vane immediately upon the last turn of the screw which holds the blades in place. I guess, Dean, that is about all."

Yes, that is about enough. I wonder what other men do with the *Manual Training Magazine*. I know that Barney, of Hebrew Technical Institute, who by the way has the finest library on manual training in the world, has his *Manual Training Magazine* bound in leather. Leaves are cut, but they are not even spotted. Mr. Practical Shopman has his much-thumbed and quite greasy current copies around the toolroom, or in the top drawer of his desk. Bill The Thrifty borrows a copy from his fellow teachers. Sam The Cautious gets the school to subscribe for a copy and it is placed in the school library.

John The Ingenius gets five of his friends to write postal cards to the city

librarian, urging under different signatures that the public library subscribe to this valuable publication. Richard The Has-been discontinues his subscription because he no longer feels the need of the magazine.

William The Wise either buys two copies and keeps a loose leaf scrapbook, or card catalogs all articles, suggestions, receipts and drawings of projects, and puts this scrapbook or card index along with the Montgomery Ward catalog and the family Bible, thus proving that he is meeting his spiritual, material, and intellectual wants.

Becoming modesty leads me to say that thrift, caution, ingenuity, and wisdom so prevail upon me that I am able to write as I have for many a year for the magazine, and thus obtain a free copy.

I read, in the old days when I was myself green, the green covered *Manual Training Magazine*. Its size has always been the same. It has never adopted the more popular form. It is as set in its ways as the *Atlantic Monthly*. The material in its pages is as conscientiously arranged as tho it was to be held responsible in a court of law for all it said. Its shape is such that it is held easily in the hands as it is read. Its articles are well-balanced between those which are seriously heavy for the high-brow who is educated beyond his intelligence, and those which are purposefully practical for the low-brow who is intelligent beyond his education. It contains every month an article on equipment or a course of study or a detailed drawing of a project which is worth in itself a year's subscription. It carries each month a line of professional gossip about the other fellow which gives it all the value of a sewing-circle conversation at Four Corners. Its editorials have always stood for something worth while. They are

not soap-bubbly, nor iridescently filmy as a drop of kerosene on mile-square pond.

It is mighty hard work to edit a magazine which pleases everybody. The immature shop teacher not only wants accurate drawings of models furnished him, but he would even like to have the model itself given as a premium for subscribing. The student of education wants articles to be scholarly and made up of such words as correlation, adolescence, inner urge, functioning, coordination, mental equinox and subliminal self. The administrator wants articles descriptive of manual training or vocational education in some city school system from the angle of charts, tables and diagrams. The teacher in the country town wants to know how to do as good work as his city brother, on a \$398 equipment.

And then, there is the fellow who has a movie mind. He is so accustomed to getting things thru his eyes that all he can do is look at pictures and captions, read what he calls "snappy articles," "squibs," "hot stuff," etc. His mind flickers as do eye adjustments of the movie theatre; any article over three inches long tires him. Pictures must break the space to please him.

As for myself, I like to see whether the Magazine for the current month spells my name "Arthor," as it has for several numbers, or "Auther." I shall feel highly complimented if they ever spell it "Author." Gradually the proof reader is approaching it. Only one more letter change and she will have it.

To be editor of a magazine is not an easy job. Until I knew more about it, I always figured that the editor arrived at the office about eleven o'clock in the morning, brushed the cobwebs from the telephone, knocked his long pipe two or three times against the top right-hand drawer, waved the flies away from the paste pot, pulled out his long shears and

then sat until 12:15 trimming newspaper clippings for filling in between featured articles. I imagined that he had such a stack of manuscripts sent to him that he spent a large part of his short working day in sending back rejection slips. And finally, that he had an intelligent stenographer who went over the form and expression of all manuscripts, re-typed them and then had the whole batch forwarded to the printer with instructions, "Set them up as best you can and give me a proof in twenty-four hours." The photographs sort of placed themselves.

Nowadays I have an idea that running the *Manual Training Magazine* is not so easy as it looks. To have been reasonably consistent in all the years that Editor Bennett has carried on this educational and publishing venture and at the same time not to have had that consistency which is indicative of small minds, has not been an easy task. To have watched the growth of the manual training work, its expansion into vocational and pre-vocational training, to grow with the work, and to retain a youthfulness of mind, body and spirit, is no easy job for an editor. To watch the debit and credit side of the ledger in the days of soaring paper and labor prices ought to have been enough to crush an ordinary man. To see on your desk each month a bright, new copy of the current issue,

and yet know that in your top drawer there is in final shape all the material for next month without realizing that editorial work is as humdrum as being an automatic machine operator, is to have visions and faith and hope beyond the range of most of us. To be obliged to seek new ads and to hold old ad friends, to please them all by proper display of space and type, and to encourage the subscribers to purchase from those who advertise within the Magazine's pages, requires a Rockefellerian ability. I do not know when Bennett's silver or golden anniversary comes, but when it does, we shall realize that he has been on one steady progressive job for many years.

I am now looking at the cover of a July issue of a magazine which I hold dear to my heart. It says, "The *Manual Training Magazine*, devoted to the Manual Arts in Vocational and General Education." It has a black and white sketch by Thompson, of a boy and a ship, and underneath it the words of Stevenson, "Oh, it's I that am a captain of a tidy little ship, Of a ship that goes a sailing on the pond."

I see in this picture the symbols of the *Manual Training Magazine*—art, activity and youth. I translate the verse to mean that Bennett is the captain of a tidy little publication that goes a sailing around the world.

—ARTHUR DEAN.

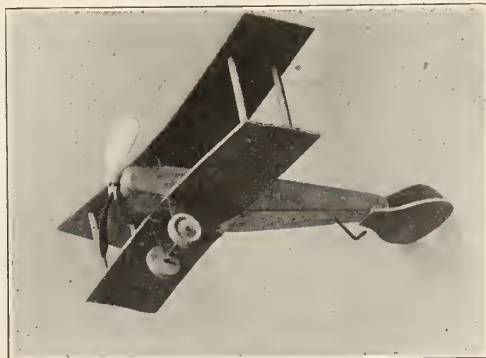

WASHINGTON CORRESPONDENCE

BUREAU OF EDUCATION CONFERENCE

I HAVE just put the finishing touches on the program of the conference of specialists engaged in training teachers of the manual arts and industrial education, which is to be held this year at the University of Michigan, at Ann Arbor, December 8, 9, 10. This is the twelfth in a series of unique conferences, the first of which was held at Bradley Polytechnic Institute, Peoria, Illinois, in 1909. Since 1914 the conferences have been held under the auspices of the United States Bureau of Education.

The conferences are representative; that is, each institution having a department for preparing teachers in these fields is invited by the Commissioner to send a representative. The attendance is therefore never very large, usually about thirty men, and all are specialists holding responsible positions in the institutions which they represent.

The program is made up each year after an expression of opinion is secured as to the topics considered by members to be of most vital importance. Seven sessions of the conference are held, and only one topic is discussed at each session. This plan provides opportunity for that freedom and thoroughness of discussion which distinguish this conference.

PROGRAM OF THE ANN ARBOR CONFERENCE

THE program for the 1921 conference is, I think, a particularly strong one. At least two distinctly new notes will be struck, and many constructive suggestions are sure to result. The topics proposed for discussion are as follows:

(1) Influence of the vocational motive in the choice of curricula by high school students.

(2) Teacher training problems of the general industrial school.

(3) Suggestions from correspondence-instruction methods.

(4) The manual training teacher's part in stimulating the creative impulse.

(5) Relations between the departments of economics and sociology and vocational education.

(6) Demands on the teacher of manual arts in the intermediate school.

(7) Progress in the development of plans for training teachers.

Thru the courtesy of the authorities, the members of the conference will be entertained in the spacious club house of the Michigan University Union. At a special luncheon on Friday, December 9th, addresses will be delivered by President Burton, of the University of Michigan, and by Dean Whitney, of the College of Education.

TWO DINNER CONFERENCES

IN COOPERATION with the officers of the two associations, the Commissioner of Education has called conferences of specialists in industrial education to be held on the evenings preceding the opening of the conventions of the National Society for Vocational Education and the Vocational Education Association of the Middle West, respectively. The former will be held in Kansas City, on Wednesday evening, January 4th, and the latter in Milwaukee, one week later.

Each of these conferences consists of a single evening session following a dinner. The general topic proposed for discussion at the Kansas City conference is: "Suggestions as to organization and administration of a program of industrial education, drawn from the experience of business and industrial plants." At the Milwaukee conference the topic will be: "Public school supervision of employed boys and girls."

DEPARTMENT OF EDUCATION PETITION

AS FORECAST in these columns last month, steps have been taken by the leading interests supporting the Towner-Sterling Department of Education Bill to bring the matter more directly to the attention of President Harding. On November 1st a formal petition was presented to the President by a committee consisting of Mrs. Thomas G. Winter, president of the General Federation of Women's Clubs, Miss Charl O. Williams, president of the National Education Association, and A. Lincoln Filene, president of the National Committee for a Department of Education.

The committee was introduced at the White House by Representative Towner and Senator Sterling. The petition recites that:

The purpose of public education is to develop good citizens. Since the citizenship of our nation is but the aggregate citizenship of the states, the nation is and always must be vitally interested in education.

If the federal government is to perform its proper function in the promotion of education the educational leader of the nation should hold an outstanding position, with powers and responsibilities clearly defined, subordinate to no one except the President.

In view of the re-organization now pending, the present is a most opportune time for giving education its proper place in the administrative branch of the government. On behalf of the national organizations which we represent, we respectfully urge that the President of the United States use his great influence to bring about the creation of a de-

partment of education, with a secretary in the cabinet.

ANOTHER STEP TOWARD
RE-ORGANIZATION

IN THIS connection much interest has centered in the executive order, issued by the President late in October, directing the United States Bureau of Efficiency to proceed at once with the application of a system of efficiency ratings, with standardized titles describing the activities and duties actually performed, for government employees in Washington. The President, of course, has no authority for directing the installation of the corresponding scales of compensation. An Act of Congress, carrying the necessary appropriations, will be required before this can be done.

A few days later, on November 3d, the committee on reform in the civil service in the House of Representatives reported out the Sterling-Lehlbach bill for re-classification of government employees, with the recommendation that it be passed promptly. And thus are revived the discussions of just one year ago as to the best method of procedure. For it is understood that the Bureau of Efficiency is basing its work on the Wood-Smoot bill, which differs from the other in certain important particulars. Will inability to agree again prevent action?

—WILLIAM T. BAWDEN.

IN FOREIGN COUNTRIES

THE ENGLISH LABOR PARTY
ON EDUCATION

THE executive committee of the Labor Party in England has submitted a memorandum to the Board of Education in which it expresses its intention of opposing without compromise, the present movement for "economy" in education. *The Times Educational Supplement* of August 27th contained a special

article dealing with this memorandum, from which the following is quoted:—

They (the Committee) believe that what we most need at this moment is a concerted policy for the development of educational opportunities and for the improvement of the educational services, and to this end they have drafted a list of recommendations which they suggest that the Board should make to local authorities.

Beginning at the bottom—in respect of age—they require nursery school teachers to be properly trained without delay, and infant school teachers

to be enlightened on the subject of modern nursery school methods and practice. When this is done, the necessary minimum number of nursery schools should be provided in every area, on open-air lines, with gardens, and not attached to existing infant schools. The hygienic standard of the elementary schools should be raised, by scrapping old buildings and equipment if necessary. Classes should be reduced to 35, and in new schools (as these arise) to 30, and the children should be given playing-fields and swimming-baths, and encouraged to organize and manage their own corporate activities. Continuation schools (regarded as a temporary expedient only) should require at least 320 hours of compulsory attendance; the curriculum should be on "broadly humanistic" lines, and the salaries and qualifications of the teachers the same as in secondary schools. Central schools should be converted into secondary schools as soon as possible, and a system of universal free secondary education inaugurated at an early date, with not more than 400 pupils in a school or 25 in a class. Other demands are for more facilities for technical education; holiday camps for all; representation of teachers on local education committees, committees of management, and advisory councils of various kinds; some representation of parents; "no military organizations within any school receiving financial aid from the State;" and so forth.

* * * * *

It demands particularly that "all narrowly vocational subjects should be eliminated from the curriculum" of the new schools. In fact it goes further, and claims that "no vocational instruction should be given in any school to a child below the age of sixteen."

Probably class suspicion has here carried the Labor Party's Executive to excess, but the demand for the abolition of vocational instruction before sixteen clears the way for the complete assimilation of the central schools in the ordinary secondary system. There is certainly nothing to hinder this assimilation and a good deal to be said in its favour. No one who is familiar with the working of such schools, especially in London, can fail to be struck by the essentially "secondary" tone of the staff. Their ambition is to maintain the highest possible level on the academic side. An unbiased outsider cannot but feel that the Labor Party need not fear an undue bent towards the vocational among the teachers of the new schools. Probably from the point of view of the general public the danger lies in the tendency to limit unduly the development of the practical side.

From the standpoint of Labor the objection to vocational training is really economic. The fear

is that young people will be trained not so as to make of each the best human being it is in his nature to become, but to produce in the quickest and least costly way the human material to be exploited by the capitalist. The "cog in the wheel ideal" is what gives the labourist cold shivers. Accordingly, he emphasizes the cultural side of education in a way that cannot fail to warm the hearts of teachers with high ideals. It is gratifying to find Labor on the side of the angels, but the anti-Philistines must take care that in triumphantly closing one door into their citadel they do not neglect another thru which a different set of enemies may make a dangerous attack.

In a sense capitalists and laborists appear to exhaust the class of people who are concerned with vocational education. But in this living, palpitating world these exact logical dichotomies are apt to prove very misleading. The parents who send their children to our schools cannot be accurately marked off into the two groups. Whatever their main bias as individuals may be, as parents they have one aim in common. They want their children to be prepared at school to make the most of life. No doubt the wiser among them emphasize "the whole" of life, and therefore take account of educational elements that do not produce their effect till later on. The less wise pay attention mainly to the immediate results on their children's prospect at the moment of leaving school. They say, Give my boy such a training that he shall be able with the minimum amount of wasted time to enter upon a life-work that will bring him what the Westminster Catechism calls "a competent portion of the good things of this life." Further, even the nobler sort of parent cannot afford to neglect this aspect. The result is that there is an increasing pressure on schools to develop the vocational side. There is no sense in burking this fact.

Educational Handwork, the official organ of the Educational Handwork Association of England, has come under new management and the magazine has been changed from a monthly to a quarterly. This change has made it possible to increase the number of pages so that it now contains forty-eight, thus presenting a better appearance. To still further emphasize the change a new cover design has been adopted. The new editor and business manager is Stewart Taylor, 4, Lydgate Road, Coventry, England.

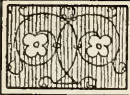

PROJECTS, PROBLEMS AND NOTES

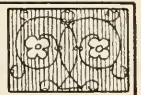

MAKING FOLDING CHAIRS

IN OUR Field Notes Department in July there was an item stating that 100 folding chairs had been made by boys from 10 to 14 years of age at the Liberty Manual Training School, Rochester, N. Y. This was an error. It should have been Pittsburgh, Pa. This error brought to our desk the accompanying photograph with a very courteous note from Supervisor Joseph M. Speer of Pitts-



FOLDING CHAIRS MADE IN PITTSBURGH
GRADE SCHOOLS.

burgh, telling us that 206 folding chairs were made instead of 100 and gave other facts concerning this rather unusual grade school problem. Later we obtained the working drawing of the chair which is reproduced on another page.

During the years 1918-20 a great deal of productive work was turned out by the Pittsburgh schools for the army cantonments, the Government hospitals, the American Red Cross and French refugees. In September, 1920, the task of making 2,000 folding chairs was undertaken by the Department of Industrial Education. These chairs were assigned to each of the high schools, to the special schools, and to those elementary schools that were equipped with certain kinds of machinery.

The Board of Education had experienced considerable annoyance with the chair problem. When public functions were given in the schools, chairs

had to be transferred from one end of the city to the other. The trucking of the chairs amounted to a large item of expense. Confronted with the problem of designing a strong, comfortable, folding chair that could be made in the schools, the Department of Industrial Education requested four of the schools each to submit a sample chair to meet these requirements. After these samples had been submitted to the Property Department, the design shown herewith was adopted. Mr. Speer says that while this design may not appeal to one at first glance, if a chair is built according to the drawing, one will be surprised at its strength, comfort and easy manipulating qualities.

Instead of relieving the Board of Education of its problems of transporting chairs for various functions, however, the immediate result is different because in most cases the principal of the school where chairs have been made have requested that the chairs remain in the service of that particular school.

A SCHOOL VISIT

A MOST interesting departure from the usual manual training program occurred in the city of Toronto, Ontario, on Friday, January 28th, 1921, when a class of boys from Victoria St. Manual Training Centre visited and exchanged lessons with the boys at Bedford Park School Manual Training Centre. The visitors were in charge of James Housego, their manual training instructor, and Miss Rita Teahan, who is voluntarily acting as their musical director outside of school hours, and is building up a fine orchestra. The visiting class arrived at Bedford Park School at 1:30 p. m., and were welcomed by John Webb, the manual training instructor who introduced them to the class then at work in the manual training room. The Victoria St. Boys quickly adapted themselves to their new surroundings and proceeded to inspect the fine manual training room, which is the most modern room of its kind in Toronto. The boys then took advantage of their opportunity to observe the Bedford Park boys at work. This was of especial interest to them, for they have no benches in their own centre, and are working, mostly in paper and cardboard, in conjunction with a course of mensuration and applied arithmetic which Mr. Housego, their instructor, has planned for their benefit. The boys of the Bedford Park class were at work making projects for use in the work of their own school. Some were working individually, and some in groups. The projects they were making were; an

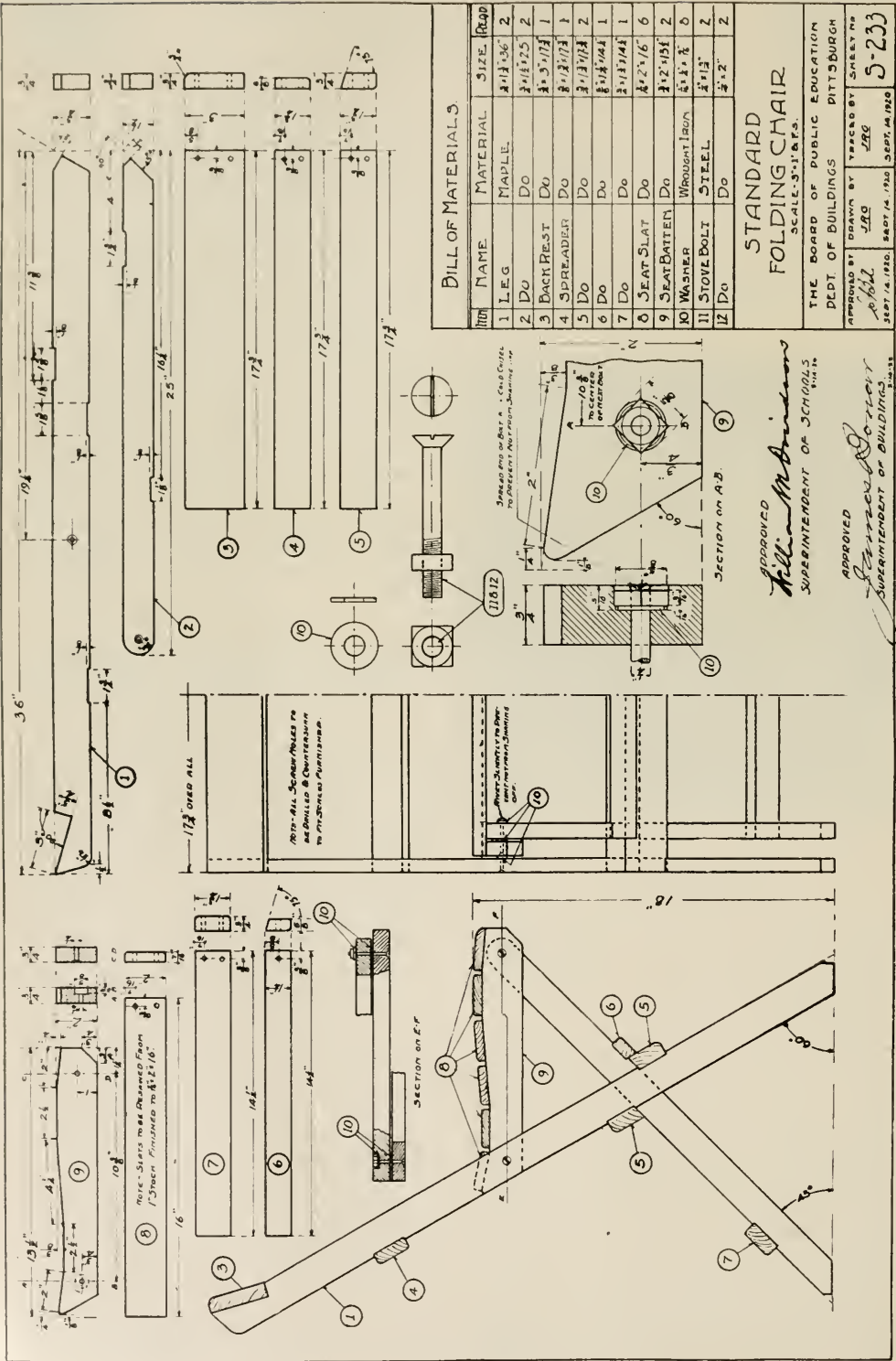

ITEM	NAME	MATERIAL	SIZE	QTY
1	LEG	MAPLE	2 1/2" x 3/8"	2
2	DO	DO	2 1/2" x 1 1/2"	2
3	BACK REST	DO	2 1/2" x 1 1/2"	1
4	SPREADER	DO	2 1/2" x 1 1/2"	1
5	DO	DO	2 1/2" x 1 1/2"	2
6	DO	DO	2 1/2" x 1 1/2"	1
7	DO	DO	2 1/2" x 1 1/2"	1
8	SEAT SLAT	DO	2 1/2" x 1/8"	6
9	SEAT BATTEN	DO	2 1/2" x 1 1/2"	2
10	WASHER	WOODRUM IRON	3/8" x 1/2"	6
11	STOVE BOLT	STEEL	2 1/2"	2
12	DO	DO	2 1/2"	2

STANDARD FOLDING CHAIR
SCALE-3/16".

THE BOARD OF PUBLIC EDUCATION
DEPT. OF BUILDINGS
PITTSBURGH

APPROVED BY: *R. H. L.*
DRAWN BY: *J. B. G.*
SCALE: 3/16"

TRACED BY: *J. B. G.*
DATE: SEPT. 14, 1920

SHEET NO. **5-233**
SEPT. 14, 1920

APPROVED
William McAndrews
SUPERINTENDENT OF SCHOOLS
PITTSBURGH

APPROVED
George D. Riley
SUPERINTENDENT OF BUILDINGS
PITTSBURGH

easel frame for sewing demonstrations in the domestic science room (group project, 3 boys), two pencil holders, a key-rack, (group project, 2 boys), a waste paper holder, (group project, 2 boys), and the remainder of the class were employed at making desk-boards for use in the art work of the various grades in the schools. The desk board and the easel frame are shown on page 216. The manual

Centre orchestra. The boys in this orchestra are mostly Polish and Jewish, and have amongst their number some remarkably fine violin soloists.

At the conclusion of the program, T. A. Lamon, principal of Bedford Park School, in a brief pithy address thanked the visitors for the musical treat, and expressed the hope that such functions would become more general, and so help to bring together

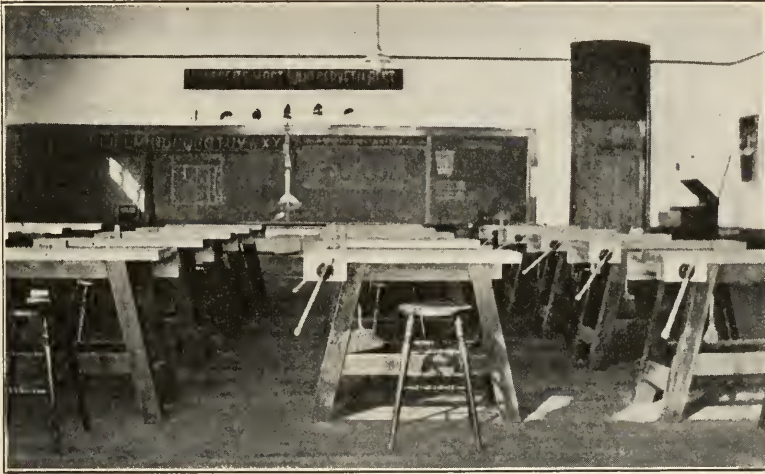

BEDFORD PARK SCHOOL MANUAL TRAINING CENTER, TORONTO, CANADA.

training class had undertaken to make eight of these boards for each of the three grade rooms. The boards are placed across the aisles between the school desks, the $\frac{3}{8}$ "x2" cleats fitting up to the ends of the desk-tops to prevent the boards from slipping. One side is used only to place objects on that are used in the art work, the reverse side is used exclusively for pasting and cutting in paper and cardboard work.

During this period, the Ontario Provincial Inspector of Manual Training and Domestic Science, A. H. Leake, entered the room. After recess, Mr. Housego took charge of his own class and gave a demonstration of his method of teaching mensuration and applied arithmetic correlated with manual training. The Bedford Park boys were interested spectators during this period, and observed the demonstration with sustained interest. Towards the termination of the period, Mr. Leake, tested the Victoria St. boys on their understanding of the subject and they responded to his adroit questions in an entirely satisfactory manner.

After an instructive and enjoyable afternoon's work both classes adjourned to the assembly room, where all the pupils of Bedford Park School had been assembled to hear and enjoy a program of music rendered by the Victoria St. Manual Training

the various racial elements and assist in welding them into a greater, better Canadian nation.

After partaking of the refreshments, the boys were taken to their dispersal centre. The event proved a success in every way, and helped to foster friendship between the boys of two schools in distant parts of the city.

—JOHN WEBB.

DRAWING OF COASTER

THE working drawing of the coaster was received from Jerome Mears of Hudson, Mass. He says of it, "I send the drawing of a coaster which I made in our manual training room for my little boy. It is possible some other teacher may have a pupil who would be glad to make one like it."

A HANDY TABLE SALT CONTAINER

SALT cellars have an unpleasant habit of becoming empty during a meal, and hasty filling more often than not results in salt being spilled. With the aid of the container illustrated herewith, salt can be handled with a minimum of trouble.

The construction is not difficult, and is suitable for project work in soldering for boys who are little experienced. Cut the bottom out of a tin can selected to fit the large opening of a tin funnel, and solder

DESK BOARD

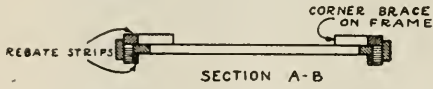
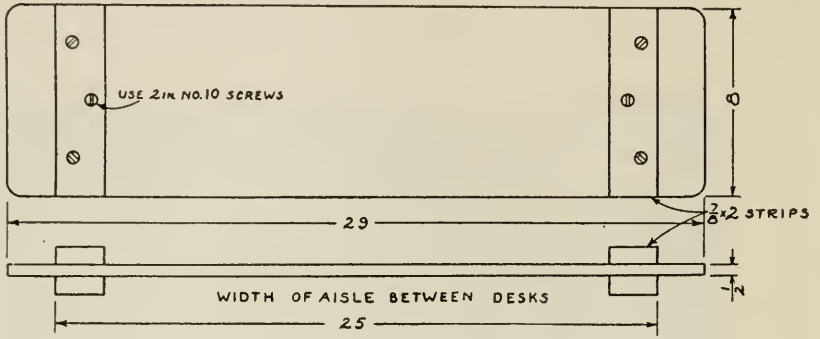

EASEL FRAME

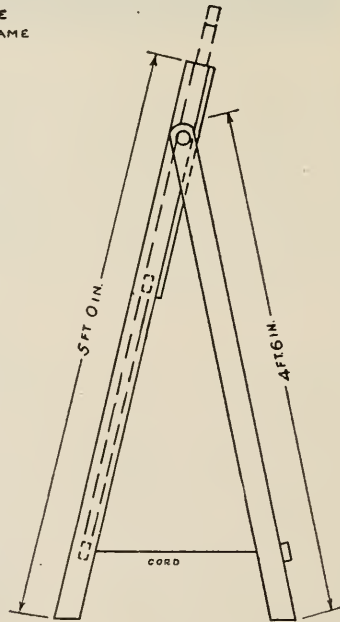
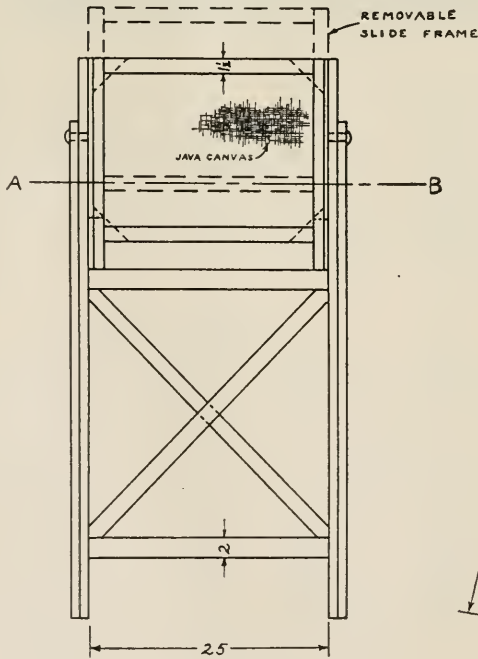

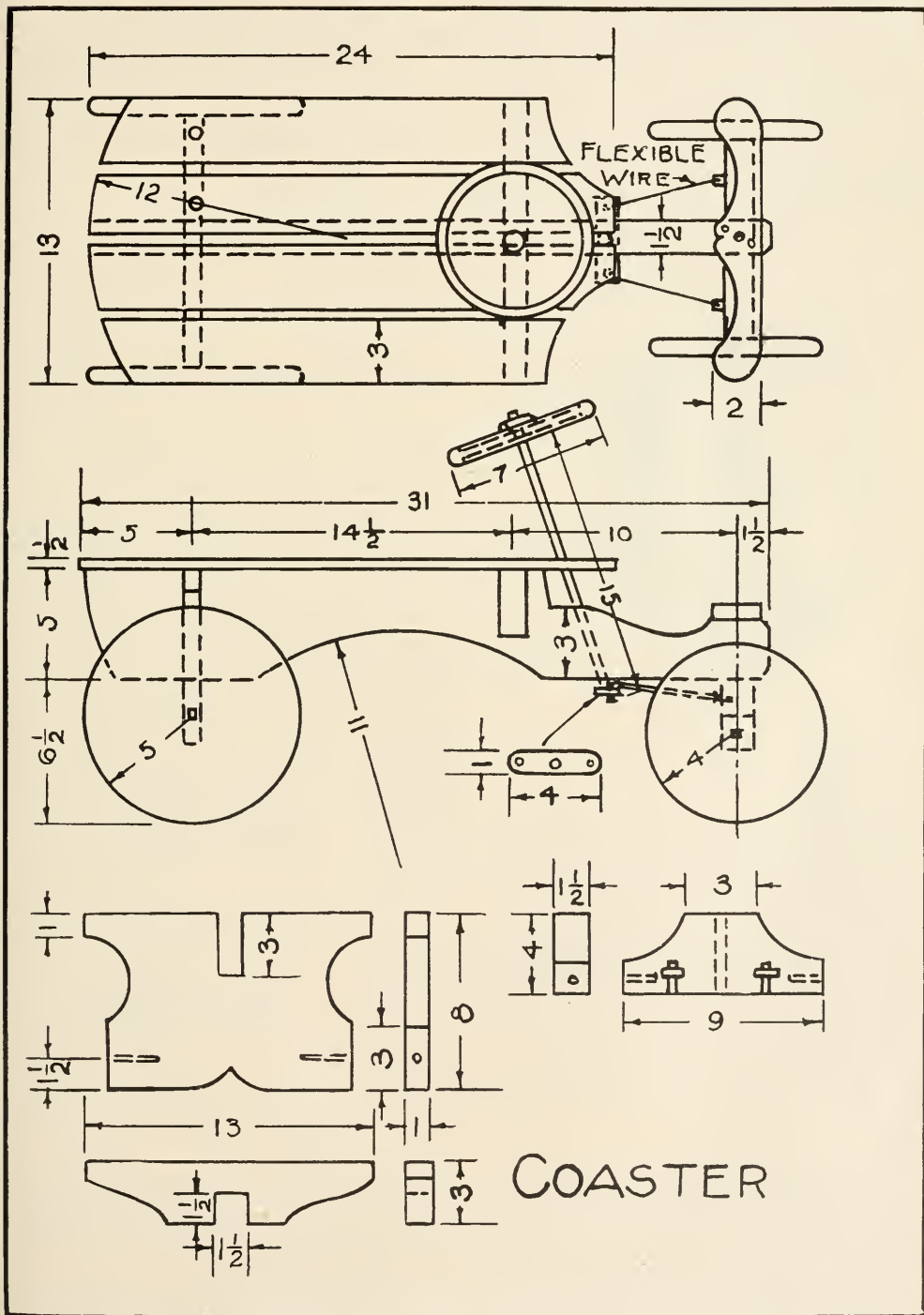

the two together as shown in the drawing to form the container. For the valve two pieces of tubing about $\frac{3}{4}$ " in diameter and 2" long are needed. One should be a little larger than the other so as to slip over it. In each cut two elliptical holes 1" long and $\frac{1}{2}$ " wide, and diametrically opposite each other. Slit the end of the smaller tube for $\frac{1}{4}$ " so that it will telescope and slip into the tube of the funnel, and solder it in place, as shown at B in the drawing. Solder a disc over one end of the larger tube to form a thrust bearing, as at A.

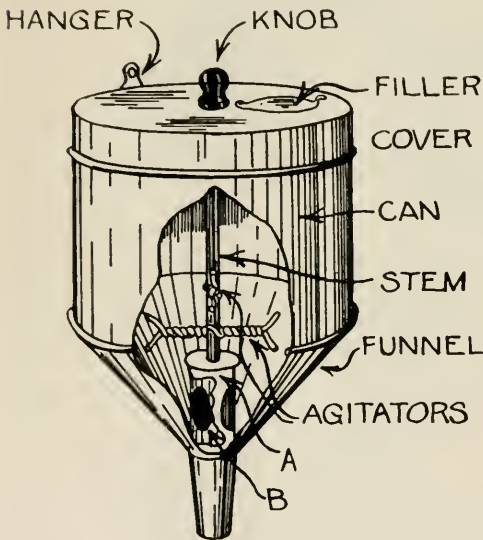

For the valve plunger use any stiff wire or rod at hand. Solder one end securely to the disk of the tube A. Slip A over the valve inside B, and mark the wire to cut off 1" above the top of the container. Thread this end; drill a suitable hole in the center of the can lid; and slip the stem thru, afterwards screwing on a small knob. The two agitators shown consist of two pairs of wires twisted about the plunger and soldered tight.

Make a filler hole in the lid by cutting out a 2" circle. Cut a disc $2\frac{1}{2}$ " in diameter for door, leaving a lug L for a hinge, thru which a rivet is passed to pivot on.

To use the container, hold the salt cellar under the spout and turn the knob of the valve. When the holes in A and B come together the salt will flow out, and the flow can be instantly stopped by turning one-quarter of the way around. If the salt is damp continue turning the knob. The agitators will break up the lumps, and the motion will cause the salt to settle into the valve.

—EDWIN M. LOVE.

A RAPID METHOD OF DETERMINING MOISTURE CONTENT OF WOOD

A METHOD used by the Forest Products Laboratory for determining the amount of moisture in chips and sample borings from large pieces of wood requires little equipment and only a few minutes time. The moisture content of pulpwood

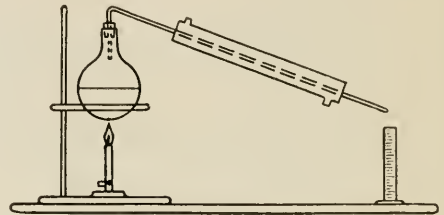

chips can be found by this method in from 7 to 10 minutes.

A specified weight of wood chips, usually 100 grams, is immersed in kerosene in a flask or retort, and the mixture is heated. The water in the chips changes to steam at 212 degrees, and goes out thru a glass tube in the cork of the flask, is condensed by a water jacket surrounding the tube, and caught in a measuring glass. The boiling point of kerosene being higher than that of water, all the moisture will be driven off the chips before the oil vaporizes to any great extent. The oil that does go off in the form of vapor is condensed and caught in the same graduate with the water. When the evaporation of moisture is complete, the oil and water are allowed to remain a few minutes until the water has all settled to the bottom of the graduate. The amount of moisture in the wood chips is then found by a direct reading.

This method has been checked for accuracy with the method of weighing samples before and after oven drying, and the variation found to be less than 1 per cent.

COPING WITH THE HIGH COST OF LUMBER

DURING the last two years, we, like many other schools, have been obliged to make several changes in our woodworking courses, owing to the enormous advance in lumber. I am enclosing a drawing of a glove box which we have adopted as an eighth-grade problem. The dimensions may be changed to make the problem suitable for a handkerchief or stationery box. The design offers an opportunity for originality.

We make these boxes from odd pieces of three-ply panel lumber which we buy very reasonably from a local furniture factory.

CURRENT PUBLICATIONS

Automotive Repair, Vol. 1. By J. C. Wright, chief, Industrial Education Service, Federal Board for Vocational Education. Published by John Wiley & Sons, New York, 1921. 6 x 9 in.; 544 pages; illustrated; price \$3.50 postpaid.

In the first part of this book are presented methods and directions for carrying out practically every job with which the general auto-repair man or the owner of a car may be confronted. Part II contains a fund of information of a more theoretical character, related to gas engines, ignition, power transmission, etc., all of which, however, is directly applicable to the mechanical work discussed in Part I.

As a background for the production of this book, the author has an experience which is related directly to the practical side of the subject which has been treated. This experience vouches for the book as a reliable source of practical information regarding automotive repairs.

Elementary Concrete Construction. By Leon H. Baxter, Supervisor of Manual Training, St. Johnsbury, Vermont. The Bruce Publishing Company, Milwaukee, Wisconsin, 1921. Size 6 x 9¼ in.; 104 pages; illustrated.

A great number of projects in concrete work with definite suggestions for their construction have been embodied in this volume. With only a few exceptions, the articles which are discussed have been used by the author in the seventh and eighth grades. Part I consists of a discussion of the history and manufacture of cement, proportioning, aggregates, reinforcing, various finishes, etc.; while Part II contains the directions and illustrations pertaining to the actual construction of the projects.

Details of Cabinet Construction. J. B. Lippincott Co., Philadelphia and London. Size 4¾ x 7¼ in.; 204 pages; illustrated; price \$1.50 net.

This is the American edition of one of a series of English books edited by J. C. S. Brough. It deals with details of cabinet construction from the standpoint of the cabinet maker. While all the principal joints used in cabinet making are covered, they are treated not as abstract joints but as parts of pieces of furniture. A chapter on table and chair legs, for instance, illustrates the making of a number of common joints but only in their application to chairs or tables, while the chapter on how to make drawers shows a number of other joints. "Cabinet Doors," "How to fit Cornice and Cappings," "Cabinet Backs and Back Framing," and "Veneering," are other chapter headings, suggestive of the contents and the scope of this book.

Hand Craft Projects. By Frank I. Solar, Northern High School, Detroit, Michigan. The Bruce Publishing Co., Milwaukee, Wisconsin, 1921. Size 7½ x 5½ in.; 158 pages; illustrated.

This book contains a large collection of toys and other small articles of woodwork, which may be made at home or in the school. In addition to this it has a number of plates showing the pictures and names of many common tools and articles of hardware, with which any person should be familiar. The purpose of this feature is partly to promote general education, and partly to make the student more intelligent in specifying his wants. The book is profusely illustrated throughout.

RECEIVED

Directed Observation of Teaching. By D. J. McDonald, professor of vocational education, University of Cincinnati. Printed by the U. S. C. School of Printing, Indianapolis. A very useful booklet analyzing the methods for observation of teaching with a particular bearing on industrial and vocational subjects.

Publications Available September 1921. A bulletin issued by the Bureau of Education, Washington, D. C. Contains a list of titles of all publications of the Bureau, giving information with reference to the conditions under which each of them may be obtained.

Northwestern Apple Packing Houses. Farmers' Bulletin 1202, U. S. Department of Agriculture. This bulletin gives information regarding storing and packing of apples, giving also definite plans for construction and equipment of apple packing houses.

Educational Progress in Wisconsin. Prepared under the direction of Cecil White Fleming. Biennial Report issued by C. P. Cary, State superintendent. State Department of Public Instruction, Madison, Wisconsin.

An Analysis of Clerical Positions for Juniors in Railway Transportation. By R. E. Berry. Issued by The University of California in co-operation with The State Board of Education, Berkeley, California.

The Constitution of the United States of America. Issued by the Bureau of Education, Washington, D. C. A pamphlet 3½" x 5", 39 pages. Price 5 cents. May be purchased from Superintendent of Documents, Government Printing office. This little book contains a copy of the constitution with all the amendments.

Seventy-eight Annual Report of the Superintendent of Schools. By Frank Cody, superintendent of schools, Detroit, Michigan. A complete report covering the growth, statistics, organization, buildings, and finance of the schools for the year ending June 30, 1921.

Between Trains in Kansas City. Published by the Convention Bureau of the Chamber of Commerce, Kansas City, Missouri. A bulletin pointing out the interesting sights, business advantages, the schools, etc. of Kansas City, Missouri.

"I can drill most anywhere with a 'Yankee' No. 1530"—



INSTRUCTIVE BOOK
Mailed FREE



Fully illustrated with engravings showing difficult and "impossible" jobs being easily done. Pictures full line of "Yankee" Tools and explains their unique mechanical construction.
Write today for it

the little Ratchet Hand Drill that drills holes in places where no other drill can work! It's only 10½ inches long, weighs but 20 ounces. With it, I can drill holes up to ⅜ in. diameter quickly, accurately and easily.

"After using this 'Yankee' Drill I soon learned that I couldn't do without it. I found out that I had to have a 'Yankee' Ratchet Drill if I intended doing *all* drilling jobs that came along.

"When set on the DOUBLE Ratchet the slightest movement of the crank *in either direction* causes the drill to cut continuously.

"Besides the DOUBLE Ratchet it has four other adjustments:—Plain Drill, Left-hand Ratchet, Right-hand Ratchet, Gears locked for changing drills.

"The little 'Yankee' No. 1530 is built along the same mechanical lines as the big 'Yankee' Drills. No other drill can do what these 'Yankee' Drills do because they alone have the 'Yankee' Ratchet."

"YANKEE"

Plain Screw-drivers

An ingenious "Yankee" device keeps blades from loosening and turning in handles. Blades of highest quality steel hardened and tempered especially for the particular use to which they are put.
No. 90 Standard style. 15 sizes, 1½ in. to 30 in. blades.
No. 95 Cabinet style. 11 sizes, 2½ in. to 15½ in. blades.



Some other "Yankee" Tools

Spiral Screw-drivers	Ratchet Chain Drills
Ratchet Screw-drivers	Automatic Push Drills
Plain Screw-drivers, 1½ to 30 in. blades	Ratchet Bench Drills
Quick Return Spiral Screw-drivers	Ratchet Tap Wrenches
	Bench Vises, removable base

Dealers everywhere sell "Yankee" Tools

NORTH BROS. MFG. CO., Philadelphia

"YANKEE" TOOLS

Make Better mechanics



GOOD TOOLS ARE ESSENTIAL FOR GOOD WORK

Since 1848 we have adhered to one policy—to handle only the very best in quality.

Our 300 page catalog illustrated above is of particular value to those interested in manual or vocational training. If you haven't a copy ask for Catalog No. 224.

**HAMMACHER
SCHLEMMER & CO.**
Hardware, Tools and Supplies
New York, Since 1848, 4th Ave. and 13th St.



FIELD NOTES—(Continued)

mentation of a minimum list of shop equipment for each unit of shop work offered; (2) the recommending of a course of study for manual training.

INDUSTRIAL TEACHERS OF MICHIGAN MEET

THE Manual Arts and Industrial Education Section of the Michigan State Teachers' Association met at the Central High School, Detroit, Michigan, October 28, with Percy Angore as chairman. The number of persons present was 252. Dr. Myers of Ann Arbor, Michigan was the first speaker. Speaking on the topic "Vocational Guidance in the Part-Time School," he pointed out how the part-time school has control over a large number of pupils with most excellent opportunities for proper placement and follow-up work. This he considers a most vital part of vocational guidance. He made the statement, further, that in order to function in the vocational guidance problem, each teacher must make himself familiar with local conditions in industry.

K. C. Smith, State Supervisor of Industrial Education, spoke briefly on the subject "Standards for Industrial Teachers." In the speech, he not only outlined the trade and vocational training required for approval of the State Board but emphasized the necessity of the vocational teacher having a knowledge of social and economic problems and also an appreciation of the purpose and possibilities of vocational guidance in connection with the work of the school.

An interesting address was then made by E. L. Bedell, who is a pioneer in the promotion of household mechanics courses in the schools of Detroit. In his talk he contrasted household mechanics and manual training by saying that manual training produces a product which may be carried home under the arm, while the product of household mechanics classes is carried home in the head. He made the point that school work in household mechanics may be carried on at much less expense than can manual training, and for this reason this new work appeals to school boards and tax payers. The subject is taught from the standpoint that all boys are interested in a home and its care and maintenance. This address was based on fact obtained from experience and was much appreciated.

Dr. Filbey of University of Chicago gave an illuminating address on "Vocational Guidance in the Intermediate School." At the close of this address a business session was held in which Earl L. Bedell was elected chairman for the coming year and was instructed to appoint his own secretary.

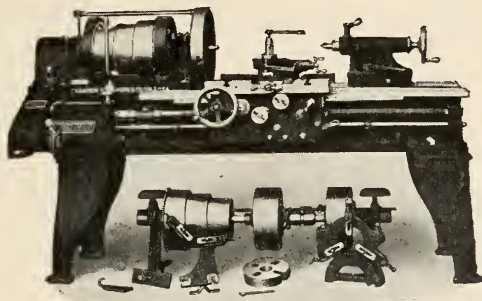

Champion Lathes

A quality engine lathe, accurate, convenient to operate and at a very attractive price to manual training and vocational schools.

Made in four sizes: 13", 15", 17" and 19"

Champion Tool Works

Winton Place

Cincinnati, Ohio

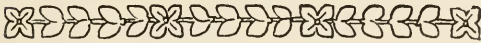

FIELD NOTES—(Continued)

MISSOURI TEACHERS IN CONVENTION

THE Missouri State Teachers' Association held its annual convention in St. Louis November 2nd to 5th. Among the various departmental meetings was that of the Department of Applied Arts and Sciences, of which Lewis Gustafson of the David Ranken Trade School was the chairman. At the first session of this department the speaker was Charles A. Bennett of Peoria. Then the audience divided into two parts according to their interest in fine arts or in vocational and manual training. To the latter group Arthur Dean gave one of his usual entertaining and thought-provoking talks which, on the program, was given the title "Many Problems and Some Solutions in Practical Arts and Vocational Training." Mrs. Anna L. Burdick of the Federal Board for Vocational Education, spoke on part-time schools.

One address on the general program, which was of special interest to school administrators, was "Educational Eating Places" by Arthur Dean. This presented the ideas that appeared in one of Dr. Dean's contributions last year to this Magazine.

PUPILS SHOP ACCOUNTS

do Not Trouble Instructors Using Our Systems. Pupils do all the Recording Accurately and "to date." All Accounts are Kept

AUTOMATICALLY

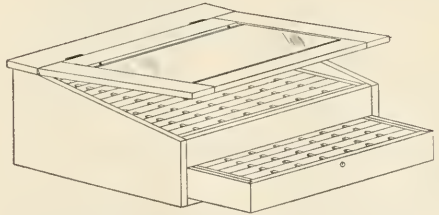

One of our Many Designs of the Industrial Arts Record. Built to Handle Any Number of Pupils.

Priced \$15 to \$85 with Liberal Discount in Quantities.

Let your problem be our burden

MANUAL ARTS SPECIALTY CO.

"Makers of Shop Efficiency"
ATCHISON, KANSAS

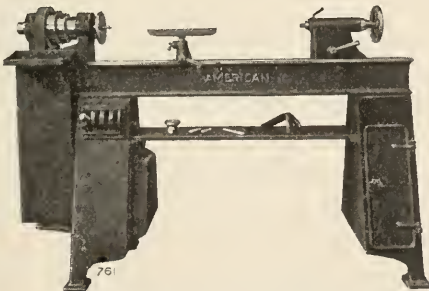

Manual Training Lathe with Motor in Base—24" to 72" Centers

AMERICAN School Equipment

High Quality Machines at Moderate Cost

SAW BENCHES
JOINTERS
PLANERS
BAND SAWS
WOODWORKERS

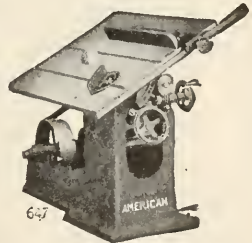

AMERICAN SAW MILL MACHINERY CO.

142 MAIN ST., HACKETTSTOWN, N. J.

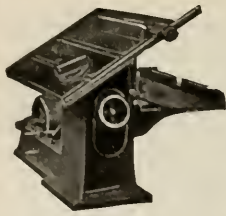

Crescent Wood Working Machines

are the tools your students will eventually use so give them the opportunity now of learning about this splendid line of wood working machinery.

Send today for our catalog of band saws, jointers, saw table, shapers, variety wood workers, planers, planers and matchers, cut off saws, disk grinders, borers, hollow chisel mortisers, Universal wood workers.

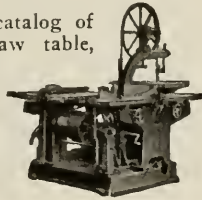

The Crescent Machine Co.

46 CHERRY ST. LEETONIA, OHIO

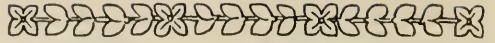

FIELD NOTES—(Continued)

TIME LIMIT FOR REINSTATEMENT OF WAR RISK INSURANCE ANNOUNCED

ANNOUNCEMENT has just been made by the Washington Office of the United States Veterans' Bureau that the time limit for reinstatement of War Risk Term Insurance expires December 31, 1921. It is very important that all ex-service men who care to reinstate their insurance which they have allowed to lapse, do so by that date for after that time no reinstatements will be handled.

Any ex-service man who is interested in reinstating his insurance may secure further information regarding reinstatement by writing, or calling at the Insurance Section of the U. S. Veterans' Bureau, 14 E. Congress St., Chicago, Ill.

OHIO TRADE AND INDUSTRIAL TEACHERS MEET

PART-TIME CLASSES, aided by Federal funds, are now operating in thirty cities and towns of Ohio. Fifty per cent of the available funds will be used this year for part-time work. Next year 75 per cent will be spent for this type of work with the allotment for evening schools correspondingly reduced. These are facts announced by E. L. Heusch, State Director for Vocational Education, to the industrial teachers assembled for a conference at Dayton early in the fall.

This conference with about one hundred men and women in attendance held its meetings in the "school house" of the National Cash Register Company upon the invitation of the president John J. Patterson. J. C. Wright of the Federal Board for Vocational Education presided over the meeting. L. A. Wilson, State Director for Vocational Education, New York, and President of The National Society for Vocational Education was one of the principal speakers. Dr. F. G. Barr of the National Cash Register Company spoke on "The Effect of Child Health on Industry." He pointed out that "in the end industry shares with society the burden of children who are defective or deficient." The many cases of tuberculosis and heart trouble with which the factory has to deal can be traced back to

The Student Needs Printing

as much as he needs the alphabet

Q It is as much a part of Education as English, the Rule of Three and History. It is, in fact, a combination of all studies—a practical illustration of all the student learns from teachers and books. It is at once a science, an art and an occupation. It gives him manual, mental and moral training. It helps him form habits of industry, accuracy and taste. It is a joy to the learner and a splendid asset in every relation of life.

Q We supply printing outfits for schools, and give the benefit of our experience and that of schools which have tried out the plan. No school is complete and doing its best work, or near its best work, unless printing is a part of its equipment.

Q Send to us for help in your problem.



Barnhart Brothers & Spindler

Type Founders

Chicago Washington, D.C. Dallas Saint Louis
Kansas City Omaha Saint Paul Seattle

TOOLS

For Manual Training Shops.
Send your inquiries to and get the especially low prices quoted by

MONTGOMERY & CO. Inc.,
105 Fulton Street New York City

THE BEST TOOL HOLDERS MADE

We Give Special Rates to Schools

Ask for our full catalog, with net prices.



Toolholders
Expanding Mandrels
Vises for Schools
Shop Equipment
Emery Wheel
Dressers, etc.

THE WESTERN TOOL AND MANUFACTURING CO., Springfield, Ohio

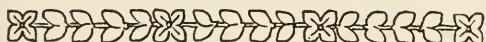

FIELD NOTES—(Continued)

the neglect of children and minors. Results of investigations which have been made were used as a basis for these statements.

A trip thru the factory disclosed many interesting facts regarding the working conditions and the splendid co-operation prevailing in the National Cash Register Company plant.

ITEMS OF PROGRESS

EVENING SCHOOLS IN VINCENNES

When, in 1914, a group of people of the city of Vincennes, Indiana, proposed to launch an evening school program, there were many citizens who had conscientious objections to the scheme. The general opinion of the opponents was that "it can't be done. There are no people in Vincennes who will attend evening schools."

Evening schools were opened, however, and in the second term of the first school year showed an enrollment of more than 500. In the second year the attendance was 650. While the war reduced the attendance a great deal the schools have served more than 1,700 evening students during the five years of their existence.

CUSHIONS

Stuffed Cushions. Well made so that filling cannot lump or cushion lose its shape.

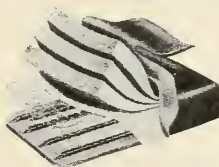

Spring Cushions. Strongly made, comfortable, neat in appearance and which will last a life-time.

Upholstery Supplies. Leathers, Imitation leathers, Burlap, Webbing, Springs, Gimp, Upholsterers' Tacks and Nails. Everything required for first-class upholstery.

Write for Descriptive Circular and complete information for ordering



Formerly Kunkle-Karl Co.

126 N. Washington St. Peoria, Ill.

MAYDOLE HAMMERS

THE WORLD'S STANDARD

Highest Quality Steel Handled Hammers
Guaranteed First-Class in Every Respect

*Booklet of Useful Information
for each student on request.*

The David Maydole Hammer Co.
Norwich. N. Y., U. S. A.





Manual Training Bench, No. 16

which is furnished with one Abernathy Rapid Acting Vise, and with one drawer.

Ask for our new Catalog No. 27

C. CHRISTIANSEN

BENCH MANUFACTURER

2814 W. 26th St. CHICAGO, ILL.

SAW TABLES For MANUAL TRAINING

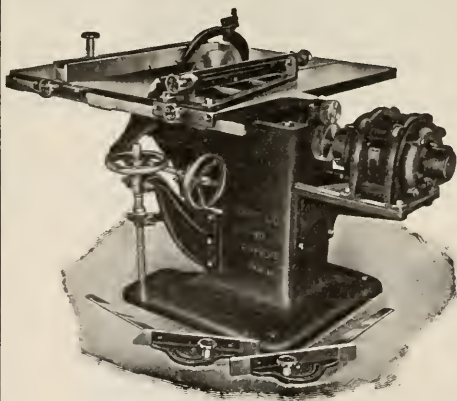

This cut shows our motor driven spiral gear saw table. No countershaft, no belts. Tilting or stationary tops. Write for circular and prices on our entire line. Address

ALEXANDER DODDS CO.

451-453 Monroe Ave., N.W.

GRAND RAPIDS, MICHIGAN, U. S. A.

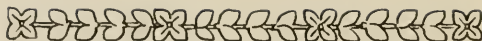

FIELD NOTES—(Continued)

This year the schools opened for enrollment October 3. Many courses have been added and all the work has been strengthened thru the experience of previous years. The courses now given are of two types—those that fall under the provisions of the federal and state laws and are aided by outside funds; and those which are wholly supported by local funds.

Mechanical drafting, architectural drafting, trade mathematics, household management, cooking, garment making, and millinery are among the courses which receive aid. For these there are no fees charged. There is also a class in elementary school studies for those who find themselves deficient in the elements of an education.

The classes in salesmanship, accounting, and other commercial courses, as well as those in china painting, art, and athletics for women receive no outside financial support. For these a small fee is charged. The salesmanship class is sponsored by the local advertising club.

HOUSEHOLD MECHANICS AGAIN

A course in household mechanics is given this year to a group of eighth grade boys in the schools of Muncie, Indiana. Sixteen boys were admitted to a class which is in session six hours a week and which will cover thirty-six different groups of problems pertaining to household mechanics. This course is perhaps broader in its scope than many of a similar type in other places, including as it does such topics as, the city building code, flowers and shrubs, the use of the kodak, etc. in addition to the ones which are generally included in a course of this kind. If the course proves valuable, it is planned by Paul V. Wooley, head of the manual arts department, to introduce the work into the curriculum of the high school next year.

Build Your Own PHONOGRAPH

Instructive—arouses pupils enthusiasm—provides one of the best problems in cabinet making.

Let Your Pupils Build
Choraleon Phonographs

We furnish plans, blue prints, motors, tone arms, case material—in fact, everything required. Full instructions. Choraleon's have fine tone. Play any record. Ask for particulars.



CHORALEON PHONOGRAPH CO.
1221 7th St., Elkhart Ind.

JUST PUBLISHED

ART AND EDUCATION

IN

WOOD TURNING

BY WILLIAM W. KLENKE

Instructor in Woodworking and Architectural Drawing, Central Commercial and Manual Training High School, Newark, New Jersey

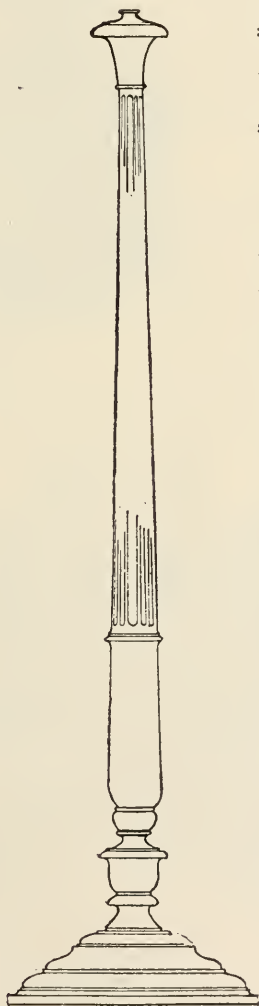

A TEXTBOOK AND PROBLEM BOOK FOR THE USE OF STUDENTS

IT is seldom that one finds a book which so admirably combines the skill of the craftsman with the appreciation for beauty in line and form of the artist. Mr. Klenke is not only an expert turner with a keen appreciation of beauty, but is also a successful teacher. His book meets all the requirements of the classroom for both text and problems. It offers complete detailed information regarding the tools to be used, sharpening and care. The use of each tool is illustrated and described—for example one section heading is "The Skew Used for Smoothing Cylinders," another "The Skew Chisel for V's and Beads." Well made drawings illustrate the various processes which are supplemented with photographs where needed. As a problem book it is superior to any now published. Altogether there are 39 full-page plates of working drawings including the following:

- | | |
|----------------------------|--------------------------|
| Shoulders, V's and Beads, | Nut Sets |
| Coves, | Drawer Knobs and Caster |
| Darning Ball | Cup |
| Potato Masher | Match Box Holder |
| Indian Club | Bath Room Stool |
| Dumb Bell | Napkin Rings |
| Screwdriver Handles | Drawing Set |
| Turning Tool Handles | Bread Board |
| Mallet | Tea Pot Stands |
| Gavel | Tray and Frame Mouldings |
| Rolling Pin | Boxes |
| Umbrella Handles | Girl's Dresser Set |
| Candlestick | Sewing Set |
| Electrolier or Candlestick | Nut Bowl |
| Lamp Standard | Clock Casing |
| Flower Holder | Tea Wagon Wheel |
| Smoking Stand | Croquet Set |
| Collar and Button Box | Four Post Bed |
| Cheese and Cracker Dish | Floor Lamp |

Price, postpaid \$1.40

Discount in Quantities

THE MANUAL ARTS PRESS
PEORIA, ILLINOIS

CABINET CLAMPS

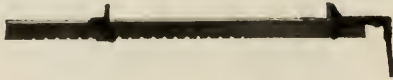

Where Black Bros. Clamps are known there is no Second Choice.
KNOW THEM
 Send for bulletin today.
THE BLACK BROS. CO.
 Mendota, Ill.

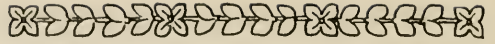

FIELD NOTES—(Continued)

COURSES IN CRATING AND BOXING POPULAR

The industries of the country have responded to the practical course of instruction in boxing and crating at the Forest Products Laboratory, University of Wisconsin, to such an extent that at the end of the tenth course, July, 1921, 24 different industries in 46 cities had been represented; twelve firms had been represented by two or more men; two firms had sent men to three courses, and one firm had sent men to four courses.

On account of this response, it has been deemed advisable to announce dates for three courses in addition to the November course previously announced. The dates for the courses are as follows: January 9-14, 1922; March 6-11, 1922; May 1-6, 1922.

RED CROSS PROVIDES FOR VETERANS

The National Headquarters of the American Red Cross has made an appropriation of \$175,000 to provide recreation facilities for the war veterans who are receiving vocational training under government supervision. The money will be used for equipment of recreation rooms at training centers.

Lumber

All Kinds of Domestic and Foreign Woods

Frank Paxton Lumber Co.
 Kansas City, Kansas

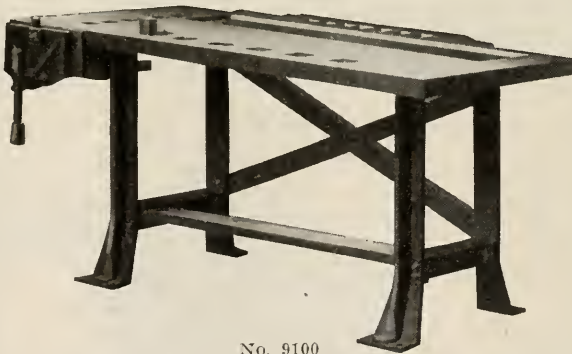

No. 9100

Built To Give Enduring Satisfaction—

Mr. Arthur Kinkade of the Board of Education of Decatur, Ill., writes of the laboratory equipment furnished by us for the new Roosevelt Junior High School:

"The cases, tables, desks and special pieces made by you are, in my judgment, very high quality, indeed. I believe I know cabinet work when I see it, having spent some ten years in the wood-working trade, and I want to say that you have an excellent product."

Consult us when you want standard or built-to-order manual training or laboratory equipment. Keep our catalog on file.

Wiese Laboratory Furniture Co.
 ENGINEERS AND BUILDERS
 Factory: Manitowoc, Wisconsin

WIESE LABORATORY FURNITURE

Ask for our new Catalog No. 28

SALES OFFICES:

- 14 E. Jackson Blvd., Chicago, Ill.
- 806 Observatory Bldg., Des Moines, Ia.
- 511 Kemper Bldg., Kansas City, Mo.
- Louisville, Kentucky.
- Otterbein, Indiana.
- 121 Chartres St., New Orleans, La.
- 244 Third Street, Portland, Ore.
- 1610 Bryan St., Dallas, Tex.
- 101 Market St., Harrisburg, Pa.
- 1238 Newton Ave., N., Minneapolis, Minn.
- 48 Barrow St., New York, N. Y.
- 310 East Bridge St., Streator, Ill.



Ask the publisher of
this magazine about
our reliability

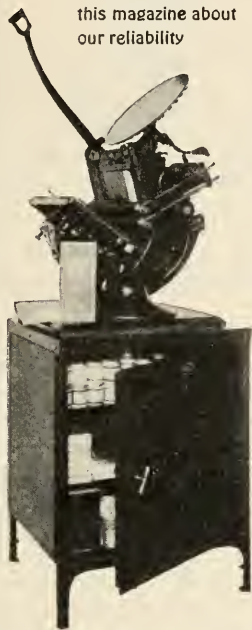

Art Printing Outfits

PRINTING outfits installed in your schools should suit the purpose for which they are installed. Vocational and prevocational printing outfits should be ample in size and contain up-to-the-minute equipment. Art printing outfits, however, may be smaller in size and not quite so efficient as regards quantity production. Our hand-lever press printing outfits are designed for the small rural school or the drawing room in the city school. They are capable of producing almost any kind of printing where large production is not required, but they are not intended for vocational or prevocational instruction. These outfits are adapted especially to the printing of linoleum blocks. Everything needed for this class of work is included in the outfit.

Write for prices, literature and information

Linoleum Block Printing Supply Co.
263 Whiton Street, Jersey City, N. J.



The very finest lead pencil is not too fine—and not too expensive in the long run—for Free-hand Drawing and Mechanical Drawing in the upper grades in the High School.

For such work specify

**DIXON'S
ELDORADO**
"the master drawing pencil"

*Free Samples Sent to Teachers
upon Request*

JOSEPH DIXON CRUCIBLE COMPANY

Pencil Department 19J

JERSEY CITY, NEW JERSEY, U. S. A.

No More Loose Handles

Don't take chances with Hammers with ordinary Wedges when you can now secure the **UNCLE SAM BRAND** Hammers with the new **VAUGHAN'S EXPANSION WEDGE**.

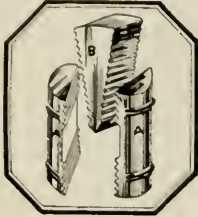

If the handle shows any tendency to become loose simply set the Wedge (B) a notch or two deeper between the pins (A) and a tight handle is assured.

UNCLE SAM HAMMERS are the only Hammers that have been approved by the **UNDERWRITERS' LABORATORIES** and each Hammer has the Underwriters' Label. It took 900 lbs. more pressure to pull the handle through the head with the **VAUGHAN'S EXPANSION WEDGE** than with the Ordinary Wedge. Uncle Sam Hammers are made in all patterns and sizes. *Write for description booklet No. 10 which describes this line in detail.*

VAUGHAN & BUSHNELL MFG. CO.

2114
Carroll
Ave.



Chicago,
U. S. A.

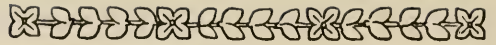

FIELD NOTES—(Continued)

EASTERN ART ASSOCIATION TO MEET AT ROCHESTER

A MEETING of the Council of the Eastern Arts Association was held in New York City on October 15th, on the call of President F. P. Reagle of Montclair, in order that plans might be made for the next or 12th annual convention of the association at Rochester, New York. It was decided to place the date for the convention on Thursday, Friday and Saturday, April 6, 7, 8, 1922.

The main topic of the program will be—"The place of the Manual, Industrial, Household and Fine Arts in the Junior High School. The junior high school system is one of the features of the Rochester school system, and the work of these schools should prove most interesting to the visitors.

James F. Barker, Assistant Superintendent of Schools of Rochester and a member of the Council of the E. A. A., was appointed chairman of the Rochester Local Committee. Mr. Barker is to organize the various committees necessary to the success of the convention.

PROMOTION IN STATE INDUSTRIAL FORCE IN MAINE

E. K. Jenkins who has had the office of state supervisor of trades and industries in the state of Maine has been promoted to acting director of vocational education. Ray E. Haines of Old Orchard has been appointed successor to Mr. Jenkins. Mr. Haines is a graduate of the New Hampshire State College where he received his degree of B. S. in mechanic arts. He has served several years in the industrial work, having been connected at different periods with the Laconia Car Company, the Merrill Contracting Company, and the Curtis Aeroplane Company. He also has had a number of years of teaching experience in New Hampshire and Connecticut.

J. H. McCLOSKEY GOES TO THE STOUT INSTITUTE

J. H. McCloskey, who has been associated for some time with the War Department Research and Development Service at Camp Grant, in the capacity of Development Specialist, has recently accepted a position at The Stout Institute, as an instructor in the metalworking department.

Mr. McCloskey has had a varied training and experience which make him well prepared for his present position. He has a degree of B. S. from Columbia University. In addition to this, he has attended at various times Ohio State University, Oberlin College, Bradley Institute, and The Stout Institute, and has taken night school and extension

Keep the Man Going Who Keeps Industry Going

What oil is to the machine, health is to the worker. The efficiency of both is essential to good business.

An average of 2½ years of productivity would be added to the life of every individual who reaches the age of 17, if there were no fatal cases of tuberculosis. The economic loss to America due to tuberculosis is more than \$500,000,000 annually,

It is your responsibility to combat this human and economic waste.

Do it with Christmas Seals.

your
Christmas Seal  Christmas Mail

The National, State and Local Tuberculosis Associations of the United States

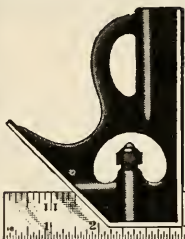

NEW
No. 65 **LUFKIN**

**"UNIVERSAL"
TRY AND MITRE
SQUARE
FOR WOODWORKERS**

**HIGH GRADE YET POPULAR PRICED.
ACCURATE—DURABLE—WELL DESIGNED.**



9-inch \$1.75
12-inch \$2.00

Distinct marking; movable yet secure head. Serves also as marking, height and depth gauge, and separate rule. *If Unobtainable at Dealers Write Us Direct.*

Send for Catalogue

THE LUFKIN RULE CO.

SAGINAW, MICH.
New York

FIELD NOTES—(Continued)

work with a number of other institutions. His practical experience covers a period of several years and includes railroad yard operations, machine shop practice, and tool making.

MENTION WAS MADE in the last issue of the *Manual Training Magazine* of the fact that R. C. Keople had been appointed certification officer of Rochester, New York. Contrary to the impression made by this notice, Mr. Keople has not given up the directorship of manual training in the city of Rochester, but has only added the duties of his new office to those which he already had.

"JORGENSEN"

Peerless Hand Screws

are not only Adjustable
but excel on ordinary
straight work.

Steel Spindles
Steel Nuts
Hard Maple Jaws

**Adjustable
Clamp Co.**

216 N. Jefferson St., Chicago

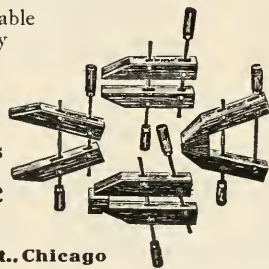

RIGHTLY NAMED

We have recently mailed our SEVENTH ANNUAL CATALOG OF "HARD-TO-GET" MATERIALS to schools in all parts of the Country. In response many Instructors have written us that this catalog is most rightly named as it lists a large number of items impossible to obtain from the usual sources. This latest catalog of Cabinet Hardware, Furniture Fittings, Upholstery Supplies, etc., will be mailed promptly to any instructor.

CHEST TRIMMINGS

Solid Copper Bands and Fancy Designs, Coppered Nails, Locks, Handles, Hinges, Cover Supports. Also Chest Corners, Edge Binding, Hinge Plates and Handles in Hammered Old Copper Effect. Casters and Sliding Devices in various styles and sizes.

Dennison Glue Stanley Tools Johnson Stains

THURSTON MANUAL TRAINING SUPPLY COMPANY

Jobbers and Manufacturers

Anoka, Minnesota

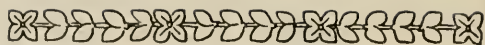

TRADE NOTES

EXPANSION WEDGE FOR HAMMERS

Many little difficulties are met day after day. Some are bothersome, altho little, and apparently there is no way to eliminate them entirely.

One of these troubles have been with hammers—the handles will work loose. Manual training teachers, like all users of hammers, have met this difficulty, each in his own way. That a practical means for keeping the head and handle tight has been developed after so many years, indicates progress. This development has come about thru the careful study of the use, construction, refinement of design, etc., of that one simple tool. This difficulty with all hammers has, at last, been solved by the use of an expansion wedge which takes care of the shrinkage of the wood. The wedge consists of three parts made to engage each other by means of teeth, which prevent slipping and yet allow for tightening.

The Vaughan & Bushnell Mfg. Co., originators of this expansion wedge, have secured the approval and label service of the Underwriters Laboratories. Before placing their approval, the Underwriters subjected the hammer to various severe tests and even went so far as to investigate the shop methods.

The hammers manufactured by this firm with the expansion wedge, are put out under the new trade name of "Uncle Sam." For detailed information, write for descriptive booklet "A Notable Achievement in Hammer Construction," to the Vaughan & Bushnell Mfg. Co., 2114 Carroll Ave., Chicago, Illinois.

TOOL CATALOG

The Western Tool & Mfg. Co., of Springfield, Ohio, manufactures a line of goods of particular interest to instructors of machine shop work.

Their new catalog No. 18, a 96 page booklet, gives complete descriptions of their "Champion" turning tools, tool holders, lathe dogs, mandrels, shop furniture, vises, hack-saws, etc. Get a copy of this catalog for your file and investigate their line before placing your next order.

NEW ENGINE LATHE

The Sebastian Lathe Company of Cincinnati, Ohio, have recently put on the market, a new lathe which has many features to commend it for school shop use. It has all the modern improvements in the way of a new designed quick change gear box, thread chasing dial, a massive apron, carriage, compound rest, and an improved tailstock. It is so designed as to do away with the feed rod.

The sturdy construction offers a reasonable assurance against breakage by inexperienced students.

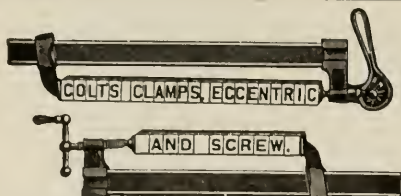

Forty styles of Quick Acting Clamps for the Worker in Wood, Cement and in the trades generally.

Your dealer will supply you.
Ask for catalog No. 296.

BATAVIA CLAMP CO.

237 Center Street BATAVIA, N. Y.

L-U-M-B-E-R

We Specialize in
Manual Training Lumber

No order is too large or too small to receive our careful attention

John S. Benedict Lumber Co.
419 N. Halsted St. CHICAGO

SIMPLIFY GRINDING

With Mummert-Dixon Oilstone Grinders. Five wheels for almost every class of grinding. They accomplish the work quickly and accurately. With this machine your students can experience the pleasure of sharp tools.



The Modern
Edge Tool
Sharpening
Machines.

The
Standard
for all
Industrial
Schools

Five
Leading
Features
Coarse Oilstone
Wheel
Fine Oilstone
Wheel
Emery Wheel
Grinder
Cone
Leather
Wheel

Furnished for motor drive or with counter-shaft
Send for full descriptive bulletin

MUMMERT-DIXON CO., Hanover, Pa.

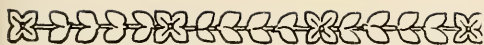

TRADE NOTES—(Continued)

This lathe is known as their 13" Type S lathe. Complete information is available in their new catalog, just published, a copy of which will be mailed to any reader of the *Manual Training Magazine* who makes the request.

NEW BOOK ON AUTO-MECHANICS

Automotive Repair is the title of a new book published by John Wiley and Sons, 432 Fourth Avenue, New York. This book contains 544 pages of well organized information on the upkeep and repair of the automobile. Directions for 118 different repair jobs with clarifying illustrations may be found in this volume with much other information of direct and practical value equally important to the car owner, the student of auto-mechanics, or the commercial automobile mechanic. J. C. Wright, Chief, Industrial Service, Federal Board for Vocational Education is the author of the book.

CHAMPION ENGINE LATHES

Engine lathe manufacturers meet many of the same problems confronting manufacturers in other lines. Questions of policy for example, whether by means of a large and highly specialized organiza-

**Marqueterie, Inlay Borders
and Purlings for**
**Manufacturers and Vocational
Schools**

Insets for Trays, Panels, Cabinets, etc. carried in stock.
 Natural and Transformed Veneers in great variety.
 Lines in Holly, Satinwood, Box, Mahogany and Black

J. BERNARD CO.
 422 to 30 East 53rd St. New York

**Machines and Tools for
Sheet Metal Working Courses**

WE have had years of experience in furnishing complete equipments for Sheet Metal Working Classes in institutions and vocational schools.
 Let us quote on the tools and machines that you need. Write for complete illustrated catalog No. 56.

Niagara Machine and Tool Works
 Established 1879
 BUFFALO, N. Y., U. S. A.

NIAGARA

"STAR" LATHES

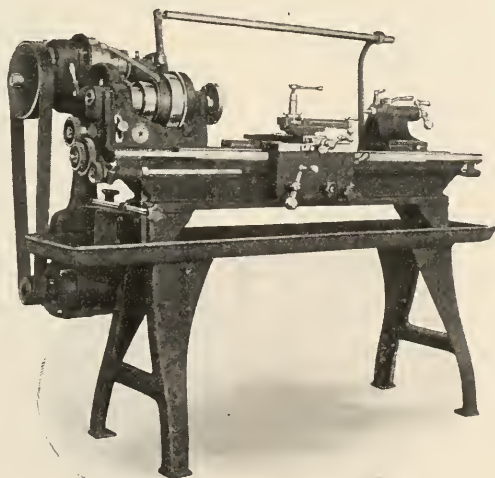

9" x 4' MOTOR DRIVEN LATHE

"Over One Million "Star" Lathes in Fifty Years—Why? Ask the User"

THE SENECA FALLS MFG. CO., Inc.
 SENECA FALLS, N. Y.

Cushions, Spring Seats Upholstering Supplies

We issue price list which also contains valuable information for Instructors in Manual Arts.

It is free—write for it.

DODGE-DICKINSON CO.
Bloomington, Illinois

Give Your Pupils SHOP-WORK THAT PAYS

Let the Boys Build Phonographs

Imagine the pride and joy of your pupils in building *their own phonographs* (equal in quality to high-priced standard machines) either to sell or take home as a source of lasting pleasure. Think how this project will add to your popularity as an instructor. Building phonographs is easy, by our methods, yet it demands precision and delicacy of workmanship, the very points always emphasized in shop practice.

Send 10c for fine illustrated catalog

and full information about our co-operative plan for manual training teachers. We plan the work for you. We supply blueprints, tone-arms, motors, case material and all accessories at lowest prices. Detailed instructions furnished. Materials best obtainable, fully guaranteed. Our machines play any make record. Write us TODAY.

HOOSIER MANUFACTURING & SUPPLY CO.
PHONOGRAPH SUPPLY DEPT.

315 Baldwin Block, Dept. A. Indianapolis, Ind.

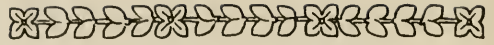

TRADE NOTES—(Continued)

tion, plant, etc., to endeavor to produce a lathe in large numbers, at the lowest cost; or to produce a lathe of high quality. The latter has been the aim of the Champion Tool Works in Cincinnati, Ohio. This firm, while not producing as many lathes as some other manufacturers, have specialized in quality production, rather than quantity, and have built their organization and plant around this idea.

The "Champion" line of engine lathes are made in four sizes, 13", 15", 17" and 19". They are fully illustrated and described in their new catalog, which, by the way, is very attractive being printed on high grade enamel paper, size 8½" x 11". Every reader of the *Manual Training Magazine* interested in quality equipment in his machine shop should get a copy of their Champion Lathe catalog.

STANLEY TOOLS IN CABINETS

Manual training teachers have noticed from time to time the development of devices, modifications in tools and complete new tools for school shop use. The Stanley Works of New Britain, Connecticut, are keen to meet the needs of the shop teacher and their line has from time to time shown changes and

FAMOUS 36" WHEEL BAND SAW

This machine is especially suited to manual training needs.

Motor driven, well guarded, accurate and durable.

Fourteen thousand now in use.

It is one of our many machines standard in commercial shops.

Put your problems up to our Engineering Division.

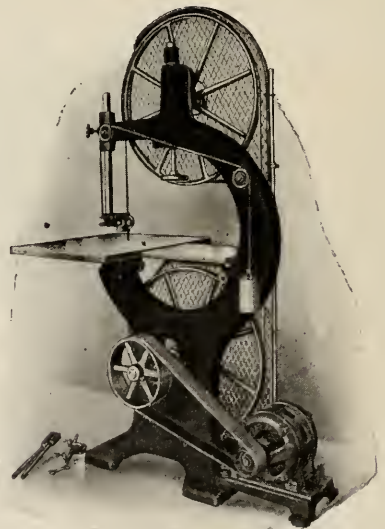

THE SIDNEY MACHINE TOOL CO.
SIDNEY, OHIO

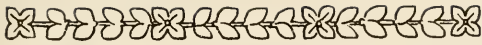

TRADE NOTES—(Continued)

new items. One of their latest developments is a line of Stanley tools in cabinets, boxes and sets. In this form, the tools are always protected when not in use, are easily accessible and in the smaller sets, are easily moved about.

The cabinets are made of black walnut, finely finished and the tools are the same high grade tools put out by this well known firm. A sixteen page booklet has just been published by them which gives complete information. Write for one and at the same time, ask for a copy of their booklet on Doweling Jigs. It shows the many uses and conveniences of this new tool which should find a place in every school woodworking shop.

A HELPFUL BULLETIN

The Oliver Machinery Co. of Grand Rapids, Michigan, publish a bulletin which will be mailed free to any reader of the *Manual Training Magazine* who makes the request. In their issue No. 4 they illustrate and describe saw benches, swing saws, band-saws, surfacers, jointers, wood lathes, trimmers, mortisers, forges, small tools, etc., and also announces two new belt sanders. Ask to have your name placed on their mailing list.

**Specialists in
Manual Training Lumber**

**Maisey & Dion
Hardwoods**

KILN DRIED AND AIR DRIED
OFFICE & YARDS 2349 TO 2423 So. LOOMIS ST.

TELEPHONES
CANAL 1830
CANAL 1831
CANAL 118

CHICAGO
THE
Great Central Market



**See
these books
for 10 days
FREE**

FRENCH AND SVENSEN—
**MECHANICAL DRAWING
FOR HIGH SCHOOLS, \$1.50**

The standard textbook—more widely used than all other books of its kind together. A real text, covering two years' work and providing an adequate supply of varied problems.

LONGFIELD—

Sheet Metal Drafting, \$2.25—A good textbook on fundamental principles.

FRENCH and TURNBULL—

Lessons in Lettering—Book I, Vertical, \$3.60 per doz. Book II, Slant, \$3.60 per doz.—A series of practice books with text, examples and exercises. Already in use in 50 schools and colleges.

GEORGE—

Advanced Shop Drawing, \$1.60. Special phases of shop drawing such as pictorial representation, patent office drawings, electrical drawing, piping layouts, etc.

FREE EXAMINATION COUPON

McGRAW-HILL BOOK CO., Inc.
370 Seventh Ave., New York

You may send me on 10 days' approval

.....

 I agree to pay for the books or return them,
 postpaid, within 10 days of receipt.
 Signed

School

Official Position

Address

.....

M. T. M. 12-1-21



CLASSIFIED ADVERTISEMENTS



Do you want to sell or want to buy some school shop supplies? Do you want to employ a teacher? Do you want a new position? Advertise your wants in these classified columns. Rate 20c a line, minimum \$1.00.

ELECTRICAL PROJECTS

BUILD "PEPCO" ELECTRIC TOASTERS—A useful and attractive project. Buy the parts from the Practical Electrical Project Co., Highland Park, Illinois. Reduced price during November and December.

BLUE PRINTS

FREE CATALOG AND SAMPLE—Blue Prints of Agricultural, Furniture Making, Mechanical Drawing, Wood Turning, Forge Work, Pattern Making and Whittling Problems. Make your work more practical. Work from blue prints. Schenke Blue Print Co., 1034 Carney Blvd., Marinette, Wis.

GRANDFATHER'S CLOCK—Blue prints, finishing material and instructions. Also works, dial, weights and pendulum can be purchased from us at surprisingly low prices. Send for particulars of our attractive offer. Clock Company, 1666 Ruffner St., Philadelphia, Pa.

MANUAL TRAINING LUMBER

YOU CAN SAVE MONEY AND TIME by buying OAK SQUARES and ASH SQUARES in Clear lumber, one to two inches thick and from 15 to 40 inches long. We also specialize in Cedar Chest lumber, Philippine and other Mahoganies. FRANK PAXTON LUMBER CO., KANSAS CITY, KANSAS.

AMERICAN WALNUT LUMBER—We carry a stock of over two million feet of Walnut Lumber, consisting of all grades and thicknesses from 1/2" to 4". Due to this large stock we are always in position to supply dry lumber for Manual Training use. Send us your inquiries. Frank Purcell Walnut Lumber Company, 12th Street & Belt Line, Kansas City, Kansas.

AROMATIC TENN. RED CEDAR BOARDS. Small shipments a specialty. Write us for prices delivered at your railroad station. Earthman Lumber Co., Murfreesboro, Tenn.

MORGAN MANUAL TRAINING MATERIALS—A perfect system of dry kiln enables us to give you lumber thoroughly dry. Carrying in stock large quantities of different woods permits us to fill your orders with the best selections. Write, sending us a list of the materials you desire. We will quote you attractive prices. Morgan Company, Oshkosh, Wisconsin.

LUMBER—Maisey & Dion, 2349 to 2423 South Loomis St., Chicago, Illinois, carry in stock a large and diversified stock of MANUAL TRAINING LUMBER. Fifteen years' experience with schools enables us to fill such orders satisfactorily.

ELEMENTARY HANDWORK

TAWIDO LOOMS with four treadles weave from 12" to 20" widths. Desk and Table Looms, 6" to 12". Tapestry loom 34". Shuttles, Yarnwinders, Warp Frames. Instruction in pattern weaving and tapestries. Elna M. De Neergaard, Tawido Looms Studio, 23 Union Square West, New York, N. Y.

EVERYTHING FOR ELEMENTARY HANDWORK—Also for basketry, weaving, bookbinding and chair caning, Mounting boards, Waldercraft dyes, crayons, burlap, scissors, punch and eye sets. Thomas Charles Co., 2249 Calumet Ave., Chicago.

POTTERY SUPPLIES

COMPLETE POTTERY SUPPLIES and equipment for Schools, Studios and Laboratories. Write for new pamphlet. Wm. W. Wilkins, Lewis Institute, Madison and Robey St., Chicago.

UPHOLSTERY MATERIALS

CUSHIONS—You know your cushions will be made right when furnished by the Grand Rapids Cushion Company. Write for estimates on cushions and all kinds of upholstery supplies. Grand Rapids Cushion Company, Grand Rapids, Michigan.

CUSHIONS, APRONS, UPHOLSTERING SUPPLIES. If you make your own cushions we can supply the materials at reasonable prices. If you want complete cushions, we know how to make them, and our prices will interest you. Illinois Valley Awning & Tent Co., 126 N. Washington St., Peoria, Ill.

BASKETRY

BASKETRY MATERIALS. Reeds, raffia, wooden bases, chair cane, Indian ash, splints, cane webbing, wooden beads, braided straw, rush, willow, pine needles, books, tools, dyes. Catalogue and Directions, 15 cents. Louis Stoughton Drake, Inc., 34 Everett St., Allston, Station 34, Boston, Mass.

PINE NEEDLES FOR BASKETRY. Brown and green, in tied bunches, cash orders 30 cents lb., not including postage; delayed payments, 35 cents lb., not including postage. Tiny cones 15 cents dozen. Miss Florence Williamson, Laurel, Mississippi.

REED FOUNDATIONS AND SUPPLIES. Veneered tray bottoms, clear pine bottoms, lamp standards and fixtures, galvanized iron containers, finishing materials, etc. Send for catalogue. The Kessel and Nyhus Co., 1733 Stanford Ave., St. Paul, Minn.

PRINTING SUPPLIES

TYPE—Manufacturers of Metal Type, Wood Type, Reglet, Brass Rule and Printers' Supplies. In no trust or combination. Empire Type Foundry, Buffalo, N. Y., Delavan, N. Y.

SCHOOL SHOP SUPPLIES

SODERING SUPPLIES, including the famous Allen Non-Acid Sodering Fluxes—in stick, paste, salts and liquid form; handy soder sets, sodering tools, aluminum soder and flux. As pioneers in the development of fluxes that far surpass muriatic acid, in every way, and as the original exponents of non-acid fluxes, the House of Allen has for 25 years maintained a position of leadership in the Arts and Crafts concerned with sodering. Send for our Bulletins. L. B. Allen Co. Inc., 4584 N. Lincoln St., Chicago, Ill.



BOOK NOTES

A FEW hundred extra copies of the November number of this Magazine were printed and are now available at the usual single-copy rates for teachers who wish to use this special toy number in their classrooms.

THE Manual Arts Press has become the publisher of the American edition of *Lettering* by Arthur E. Payne. This is a Batsford publication of superior quality. It consists of alphabets which are especially useful to designers and architectural draftsman. It gives several adaptations of the old Roman letters; also of Gothic and old English. Besides these it gives suggestions for titles and for spacing. To keep the cost of the book down, the amount of text matter is very small. The information is given almost entirely by illustrations. The price of the book is 85 cents.

THE latest book issued by the Manual Arts Press, *Art and Education in Wood-turning*, is a most attractive volume. Everyone who has seen it has expressed approval. Its excellent working drawings and diagrams and its clear illustrative photographs immediately hold the attention of even the casual observer. The text is written in such a direct, readable style that it carries the reader on easily from step to step in the processes described. The book takes a distinct step forward in emphasizing the art craftsmanship side of wood-turning, which is the most essential thing in wood-turning in public school work of whatever grade. Wood-turning without the art element does not go very far as an educational subject; with the art element it is worthy of an honored place in manual training.

IN May 1920 the Pennsylvania State College published a bulletin on "Farm Shop Work in Pennsylvania." In this bulletin it was pointed out that of the 400 Pennsylvania farms studied, fourteen farmers per hundred have forges on their farms and of that fourteen, thirteen do welding and tempering. The bulletin then presents a chart showing how many farmers per hundred made each of a list of twenty-one common objects used on farms. At the top of the list are the chain link and the gate hook. Then come in the order of frequency, chain hook, singletree hook, clevis, ring, staple, punch, gate hinge, harness hook, hasp, complete bolt, bolt head, cold chisel, wrench, angle brace, swivel, bolt nut, eye bolt, tongs, and angle iron.

It is interesting to compare this list with the problems given in *Farm Blacksmithing*, by Friese. In general they are the same. The book places the

emphasis just where the bulletin does. The book however, gives a more complete list of farm problems and a greater variety of forms of what is essentially the same problem. For instance, it gives more kinds of hooks, more than one clevis, etc. It gives thirty-seven typical problems instead of twenty-one.

THE eighth in the series of portfolios of tracings of *Shop Problems* is now being printed. From these tracings blue-prints can be made of many of the best working drawings that have appeared in the *Manual Training Magazine* during the past two years.

THE Manual Arts Press has just issued a revised edition of *Mechanical Drafting* by Miller which has greatly extended the usefulness of this standard text. The work of revision has been done by Professor R. K. Steward of the Michigan Agricultural College. The principal additions are in the appendix which now occupies seventy-two pages and includes a great variety of data useful to the student and to the machine draftsman. This now includes (1) reference tables for sizes of bolts and nuts, (2) the various types of machine screws, (3) pipe threads the various types of machine screws, (3) pipe threads, (4) standard bolts and screws adopted by the Society of Automobile Engineers, (5) U. S. standard gage sizes of sheet iron, (6) decimal equivalents for common fractions of an inch, (7) different standards for wire gage, (8) geometrical constructions, (9) conventional representations of a variety of forms and materials, (10) lighting and electrical symbols adopted by the National Contractors' Association and the American Institute of Architects, (11) symbols used in electrical and automobile construction, (12) topographical conventions, (13) conventional representation of rivets, (14) single-line symbols used in laying out piping, (15) symbols for pipe fittings, (16) symbols for air pipes, (17) patent office conventions, (18) a sample patent office drawing, (19) patent office electrical symbols, (20) methods of representing facts graphically, (21) several alphabets, (22) samples of gummed letters and figures, and (23) the report of an investigation concerning commercial drafting practice in lettering, penciling, inking, dimensioning, reproduction of drawings, and a few of the common conventions used in drafting.

Besides this comprehensive appendix the new edition contains several more problems than the earlier edition.

Educational Saw Charts Free

Set consisting of 4 blue prints, 18" x 24", each containing accurate information and details of the making of Steel, Hand Saws, Circular Saws and Files.

Write today for your set

SIMONDS Manufacturing Co.

"The Saw Makers"

FITCHBURG, MASS.

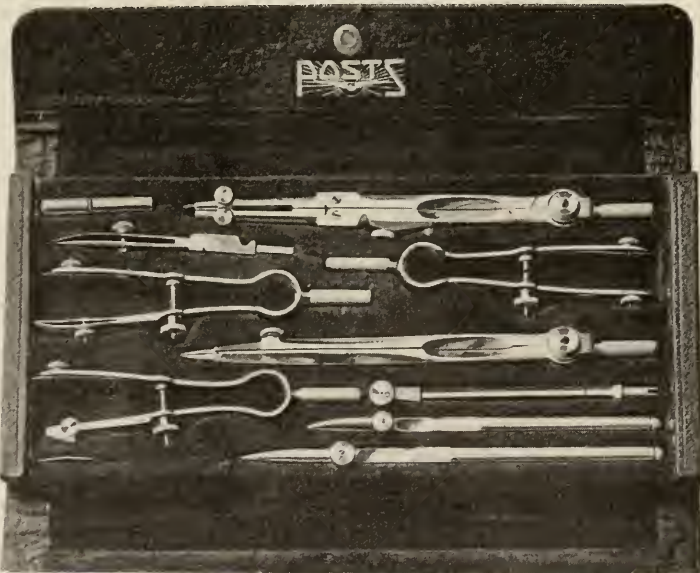

Special Offer

Unusual Bargain

No. 1070C Set in Case Ruling Pen Compass, \$2.40.

No. 1071½C Set in Case Ruling Pen, Bow Pen, Hair-spring Divider Compass, \$3.00.

No. 1073C Set in Case Ruling Pen, Bow Pencil, Bow Pen, Hair-spring Divider Compass, \$3.30

No. 1075C Set in Case Ruling Pen, 4½", Ruling Pen 5½", Bow Divider, Bow Pencil, Bow Pen, Hair-spring Divider Compass, \$3.90

POST PAID

LIMITED QUANTITY FOR IMMEDIATE ORDER ONLY

THE FREDERICK POST CO.

Salesrooms
319 S. Wabash Avenue.

CHICAGO

Main Office and Factory
3635 No. Hamlin Ave., P. O. Box 803

MANUAL TRAINING MAGAZINE

EDITORS CHARLES A. BENNETT, Peoria, Illinois.

WILLIAM T. BAWDEN, Assistant to Commissioner of Education, Washington, D. C.

ASSOCIATE ARTHUR D. DEAN, Professor of Vocational Education, Teachers College, New York City.

EDITORS: FRANK M. LEAVITT, Associate Superintendent Public Schools, Pittsburgh, Pa.

WILLIAM E. ROBERTS, Supervisor of Manual Training, Public Schools, Cleveland, Ohio.

Business Manager: L. L. SIMPSON.

Published monthly by The Manual Arts Press, 237 N. Monroe St., Peoria, Illinois.

Subscription Price, \$1.50; Canada, \$1.80; Foreign, \$2.00. Single Copies, 25 cents; Foreign, 30 cents.

Subscriptions, remittances and manuscripts should be sent to THE MANUAL ARTS PRESS, Peoria, Illinois.

CONTENTS

THE STUDENT FACTOR IN SMITH-HUGHES EDUCATION.....	<i>Frank C. Vincent</i>	221
SCHOOL SHOP ACCIDENTS AND THEIR PREVENTION.....	<i>E. E. Ericson</i>	223
SHEET-METAL WORK FOR JUNIOR HIGH SCHOOLS (With photographs and working drawings).....	<i>Charles Aberg</i>	229
EDITORIAL REVIEW FOR THE MONTH.....		242
The Manual Arts Conference—Vocational Motive among High School Students—Need for more Elementary Industrial Schools—The Creative Impulse in Industrial Work—Productive Industry Methods in the Junior High School.		
A POINT OF VIEW.....	<i>Arthur Dean</i>	248
WASHINGTON CORRESPONDENCE.....	<i>William F. Bawden</i>	251
Changes in the Federal Board—Mr. Carris resigns—Grading Enlisted Men in Army Vocational Training.		
IN FOREIGN COUNTRIES.....		254
Vocational Training and Tests—Printing School in Edinburgh.		
PROJECTS, PROBLEMS AND NOTES.....		255
A Circular Shop!—Floor Lamp and Shade—Railway Bridge—An Indirect Lighting Fixture—Another Manufacturing Problem.		
CURRENT PUBLICATIONS.....		260
FIELD NOTES.....		IV
New England Items—Around New York—Meet Me in Milwaukee—California Field Notes—From the Southwest—From New Jersey—Occupational Therapy Convention—Government Establishes Vocational Center—Items of Progress—New Appointments—The Kansas City Meeting.		
TRADE NOTES.....		XXVII
BOOK NOTES.....		XXXIX

This Magazine is kept for sale at McClurg's in Chicago, and Brentano's in New York.

Entered at the Post Office at Peoria as Second-Class Matter. Copyright, 1920, The Manual Arts Press.

7-10-1918
Field Notes
1918

FIELD NOTES

NEW ENGLAND ITEMS

George M. Morris and John Fisher have resigned their positions with the General Electric Company at West Lynn, Massachusetts where they were employed in Training-Class work, and have returned to the Boston school service. Mr. Fisher is now associated with Machine Shop Practice in the East Boston High School and Mr. Morris has been assigned to the Dorchester High School as a manual training instructor.

Ellsworth M. Longfield has returned to the Boston Trade School as department head in the Sheet-

Baker, of the machine department of the above school, was the active head of the faculty organization during the past term and deserves much praise for the efficient manner in which the work of the various departments was planned and carried out.

RECREATIONAL HANDICRAFT

One of the newest features of Boston's educational system was given a trial during the past summer and as a result the Recreational Handicraft Work will undoubtedly be extended quite materially during the coming summer vacation term. Attend-



CLASS IN RECREATIONAL HANDICRAFT, BOSTON.

Metal Shop, having recently left the employ of the General Electric Company's plant at Schenectady, New York, where he was associated with Training-Class work.

Arthur Olsen has also returned to the Boston service, after a period spent as instructor in sheet-metal work in the public schools of Pittsburgh, Pennsylvania. Mr. Olsen was formerly a sheet-metal instructor in the Tyler Street Prevocational School, Boston.

The work accomplished by the students in the Federal Board for Vocational Education Rehabilitation Classes at the Boston Trade School during the past summer is worthy of special notice, and indicates quite clearly that the high standard set for such work among the ex-service men of the Army and Navy when this work was first started in Boston is still being maintained. Robert E.

ance is purely voluntary, except that pupils must undertake to complete any problem once started. The work embraces a wide variety of experiences and includes home mechanics, furniture repairing and re-caning of chair backs and seats, making articles of furniture, toys, etc. Interest in this work is quickly secured and easily maintained in the classes and the material results obtained are well worth while.

Only two centers were opened during the past summer—one at the Mary Hemenway School, Dorchester, in charge of Orren R. Tarr, of the Cutter Prevocational School, Charlestown; the second at the Elihu Greenwood School, Hyde Park, in charge of J. Maynard Cheney, of the Emily Fifield School, Dorchester. The accompanying photo indicates the scope of furniture repairing which was carried on.

The actual raw material of Printing is language—any language

The School Paper

Published for the purpose of convincing educators of the educational value of printing in connection with academic and vocational instruction in public schools.

VOL. 1

JERSEY CITY, NEW JERSEY

No. 1

The Value of Printing in Public Schools

Reprinted from The Peabody Reflector.

THERE is a physiological necessity on the part of the child for motor activity and the foremost educators of today insist that a considerable part of the school programme should consist of activities. Printing provides for the schoolroom an activity of universal interest and high educational value.

2. Printing vitalizes other school subjects by affording opportunity for the practical application of the information acquired in them in ways that appeal to children as worth while. This is especially true for reading, language, English, and art.

3. Industrial intelligence will and should be an important objective of school work for children of the leading industrial nation in this pre-eminently industrial age. Through the printshop pupils secure a first-hand experience in the fifth industry of the country and learn its fundamental principles and processes.

4. "In the matter of social significance printing is practically ideal. Almost every problem is a community project that a number of pupils combine their efforts to produce. Practically every task in the

print shop is undertaken with the consciousness of real service to a great number of people in the school or in the community at large." The home-printed school paper has almost unlimited possibilities in social values.

5. There is just as great need of education for intelligent consumption as there is for efficient production. After food, clothing, and shelter, printed matter ranks as the next most important item utilized in the civilized world of today. Adequate appreciation of the product of an art can only be acquired through creative effort in that art.

6. The knowledge and experience obtained from a school course in printing is of considerable value, not only to the many who enter some one of the many occupations of the printing trades, and to those who become editors, authors, and publishers, but also to the much greater number who enter occupations which have much to do with printing in the way of advertising, issuing catalogues, stationery, office forms, blank work, house organs and other publicity work.



Information for Superintendents of Schools: The Education Department of the American Type Founders Company employs the services of professional educators, efficiency engineers and trained salesmen to aid you in establishing printing courses in your schools. With this company the word "service" is spelled H·E·L·P.

For information write F. K. PHILLIPS, Manager, EDUCATION DEPARTMENT

American Type Founders Company

300 Communipaw Avenue

Jersey City, New Jersey



Boston, Mass.
New York City
Philadelphia, Pa.
Baltimore, Md.
Richmond, Va.

Buffalo, N. Y.
Pittsburgh, Pa.
Cleveland, Ohio
Cincinnati, Ohio
Atlanta, Ga.

Los Angeles, Cal.
Winnipeg, Canada

Chicago, Ill.
Detroit, Mich.
St. Louis, Mo.
Milwaukee, Wis.
Minneapolis, Minn.

Kansas City, Mo.
Denver, Colo.
Portland, Ore.
San Francisco, Cal.
Spokane, Wash.



FIELD NOTES—(Continued)

BOSTON SCHOOLS SUFFER LOSS

Vocational education has recently suffered the loss of one of its ablest exponents in the death of Frank V. Thompson, superintendent of schools in Boston. By reason of training and experience he was peculiarly fitted to advance the best interests of the various branches of vocational education and a great deal of the progress made in Boston schools for several years past has been influenced by or is due to the intense interest manifested by Mr. Thompson in the advancement of such work.

Mr. Thompson received his degree of Master of Arts at Harvard Graduate School and that of Doctor of Philosophy at St. Anselm's College, Manchester, N. H. He entered the Boston school service on March 4th, 1901, as sub-master of the Chapman Grammar School, East Boston, and when the High School of Commerce was opened in 1906 he became head master, having laid the foundation for his work there by study of similar institutions abroad. On August 13, 1910, he was promoted to assistant superintendent of schools, and specialized in technical and vocational education subjects and departments, and he was chosen as superintendent of schools in 1918. Mr. Thompson originated the plan in 1917 of placing high school boys on farms and it was so successful that the plan was quite generally adopted in various sections of the country. Mr. Thompson's favorite slogan was the expression by Horace Mann: "Be ashamed to die until you have won some victory for humanity."

Mr. Thompson has been succeeded as superintendent of schools by Mr. Jeremiah E. Burke, formerly an assistant superintendent in Boston. On Tuesday, November 22, 1921, a very impressive memorial service was held in Symphony Hall in honor of Mr. Thompson, and there were over 3500 teachers and school officials in attendance.

MEETING OF BOSTON VOCATIONAL SOCIETY

The Vocational Education Society of Boston met at Hotel Avery on Saturday, November 19, 1921, and after a luncheon Assistant Superintendent John C. Brodhead, of the Boston Schools, spoke very feelingly and appropriately concerning the late Frank V. Thompson, superintendent of Boston Schools.

Mr. Royal Bailey Farnum, State Director of Art Education for Massachusetts and Principal of the Massachusetts Normal Art School, addressed the members and guests on the subject of "Art Education for Massachusetts." He pleaded for a recognition of the public demand for more art in home furnishings, in clothing and in home building,

and stated that it is the duty and function of the schools to foster and encourage the appreciation of the beautiful in art.

Also, the aim of art education should be, first, to develop taste, second, to develop artistic expression; and third, to train vocationally for industry. He expressed the earnest hope that art education in this country would be developed to the extent that we would build to bequeath to future generations all that is beautiful in life.

—FRANCIS L. BAIN.

AROUND NEW YORK

A VOCATIONAL GUIDANCE CONFERENCE

The New York Vocational Guidance Association will hold a conference on the need for vocational guidance in history. The topic will be discussed from the point of view of industrial and employment managers.

Dr. Henry Sayer, New York State Industrial Commissioner will discuss "The Right Man for the Right Work." R. D. Farrell, president of the Brooklyn Personnel Managers' Club and employment manager of the Mergenthaler Linotype Company, will speak on "The Personnel Manager and Vocational Guidance."

VOCATIONAL TEACHERS' COUNCIL MEETS

The New York Vocational Teachers' Council, Local Union 25, American Federation of Teachers, held a regular monthly meeting on the evening of Nov. 4, at the Washington Irving High School. Plans were submitted, proposing an amalgamation of all associations in the Southern District of New York State interested in the advancement of vocational education.

A TEACHERS' ART EXHIBIT

Some twenty-five of the art teachers of the city high schools, held an exhibition of little 8 x 10 canvases popularly known as "thumb-box" sketches, at the Anderson Galleries, Fifty-ninth St. and Park Ave. during the week ending November 6.

Nearly one hundred and fifty sparkling little pictures made up the exhibition. The majority of the pictures belonged to the women teachers, although about a dozen of the men teachers also exhibited work. Practically all the sketches were in oil, with the exception of one group of landscape in pastel.

The docks of New York City served as subjects, and also the Maine seashore. The sketches were about evenly divided between landscapes and marines, with a few figure groups.

Industrial Correspondence University

PHILADELPHIA, PA.

ANNOUNCEMENT

PRESIDENT T. J. FOSTER takes pleasure in advising all who are interested in industrial and vocational affairs that the Industrial Correspondence University is prepared to enroll students for the best Mechanical Drawing, Architectural Drafting, and Blue Print Reading Courses that have ever been offered to the public.

Associated with President Foster, as Dean of the University, is Harry S. Bitting, President of The Williamson Free School of Mechanical Trades. Mr. Bitting has selected as his associates in the preparation and arrangement of all the technical courses, Mr. James A. Pratt, Mech. E., Director of The Williamson Free School of Mechanical Trades, and Frederic S. Crispin, C. E., Professor of Mechanical Drawing, Germantown High School, Philadelphia, Pa.

Mr. Pratt, personally, recently completed our Blue Print Reading Course which is a masterpiece of its kind, and we unhesitatingly recommend it, not only for students, apprentices, and shop workers, but for every teacher in the vocational educational field.

By our original and unique plan of sale all of our courses will be sold in units as Freshman, Sophomore, Junior, and Senior. A student enrolling will not be required to pay cash or part payment for more than a single unit at a time. Should he fail to complete this unit, or decide not to go on with the work after he completes it, it will not be necessary for him to make additional payments. After completing the first unit he may go on with the second, and so on, to the completion of the course.

In addition to the regular student enrollment plan of sale, either for cash or on the part time plan, we have decided to sell the courses at a very special price to teachers, without service, and at a still more moderate wholesale price, in lots of ten or more, to school organizations, without service, by which we mean that it will not be necessary for them to send in lessons for correction.

If interested, either as an individual or from a teacher's or principal's viewpoint, with the thought of adopting the courses, check the coupon at right and mail it to us, after which you will promptly receive full information.

Department M,
Industrial Correspondence University, Inc.,
1504 Locust Street, Philadelphia, Pa.

Without expense or obligation on my part, please give me full information concerning the course which I have marked X.

- | | |
|--|--|
| <input type="checkbox"/> Blue Print Reading (Building Trades) | <input type="checkbox"/> Blue Print Reading (Blacksmith) |
| <input type="checkbox"/> Blue Print Reading (Mechanical Trades) | <input type="checkbox"/> Tracer |
| <input type="checkbox"/> Blue Print Reading (Plumbing and Pipe Fitting Trades) | <input type="checkbox"/> Mechanical Draftsman |
| <input type="checkbox"/> Blue Print Reading (Structural Iron Workers) | <input type="checkbox"/> Architectural Draftsman |
| <input type="checkbox"/> C. P. A. Exams. | <input type="checkbox"/> Employment Manager |
| | <input type="checkbox"/> Expert Accountant |
| | <input type="checkbox"/> Cost Accountant |
| | <input type="checkbox"/> Auditor |
| | <input type="checkbox"/> Commercial Law |
| | <input type="checkbox"/> Financial Independence |

Name

Street and Number

City and Post Office.....State.....



FIELD NOTES—(Continued)

EDUCATION IN SHOE INDUSTRY

Brooklyn's shoe industry gives employment to 30,000, and two-thirds of all the shoe manufacturing of the city is done in Brooklyn. The Shoe Manufacturers' Board of Trade of New York, which consists of Brooklyn concerns, with a few in Long Island City, is co-operating with the Department of Education, in an effort to induce graduates of the elementary schools to enter the shoemaking business.

The manufacturers have equipped a workroom in Public School No. 5, Bridge and Tillary Sts. for evening classes, and have a well-equipped model factory for daytime instruction in the Brooklyn Vocational School in the Cary Building, Jay and Nassau Sts. The evening school class is open only to those already employed in the shoe business, and is devoted to instruction in the making of specialties. The vocational school teaches the entire procedure of shoemaking.

At the present all the young men at work in the Vocational School are ex-service men, who have been placed there by the Federal Government. It is proposed to provide instruction for graduates of the elementary schools as rapidly as they may apply. Members of the Brooklyn Chamber of Commerce have been asked to advise young men to confer with James H. Allen, principal of the Brooklyn Vocational School at the Cary Building. The course is free to all recent elementary graduates.

Brooklyn leads the nation in the value of the shoes it produces. Several American communities excel Brooklyn in the quantity production of shoes, but this borough specializes in high-grade shoes, and in the value of its products stand far in the lead in the shoe making industry. Working conditions are on the highest plane. The work is clean, the wages are attractive, and arrangements between the employers and the unions have worked harmoniously and to the benefit of the industry. These conditions cannot continue unless enough workers can be secured of the right degree of intelligence. For this reason the manufacturers are conducting an aggressive campaign to acquaint elementary school graduates with the many opportunities the shoe industry affords.

A CO-OPERATIVE SCHOOL

The Haaren High School at Huberts and Collister Sts., pioneer in the experiment with the co-operative plan, can easily care for more than five hundred more pupils. It has 528 pupils now on the register, and some 260 are in co-operative classes; that is, they are paired, and spend the time alternately in schools and in big stores, offices, etc. At the same

time the school is offering full commercial courses to those who do not desire to enroll in the co-operative plan.

This is the second year of the school, and the seventh year of co-operative courses in the local high schools. The industrial co-operative courses are conducted in the Manual Training High School, and there is a salesmanship course in Newtown High School.

The co-operative courses are not making the headway that was anticipated when they were authorized in 1913-14.

The decision to bring all of the co-operative students together in one high school grew out of the conviction that centralization would make possible not only, more efficient organization, but also increased opportunity to serve the needs of individual pupils and co-operating employers. This centralization has never been carried out completely. The present unemployment situation has reduced the number of possible places to which the paired students may be assigned. These co-operative students, who are awaiting assignment to some firm for their week out of school, are being given special courses at school during the week that otherwise would be spent in the office. The co-ordinate teachers are giving special lectures and generally the students are getting a great deal out of the extra study week.

The continuation school law has operated to interfere with the work of the school, as it has rendered it almost impossible to place the younger pupils in positions. The sophomore pupils, who find it necessary to earn money to enable them to continue at school, are generally sent out to clerical positions. The juniors find employment as typists and the seniors as stenographers. There is also a special salesmanship group.

Before pupils are sent out, all positions are carefully examined by a teacher whose duty it is to co-operate the work and the teaching. The school exacts high standards as to surroundings, type of work, hours, and compensation. In this way pupils acquire actual business experience while at school. The schooling is most practical and the students begin a business career, while still under the supervision of the school authorities.

Although the Haaren High School is a special type of co-operative high school, a number of its students are taking the regular course of study—three or four year commercial. It specializes in secretarial accounting and salesmanship.

Principal W. R. Burnham is enthusiastic over the work of the students, and while keenly interested

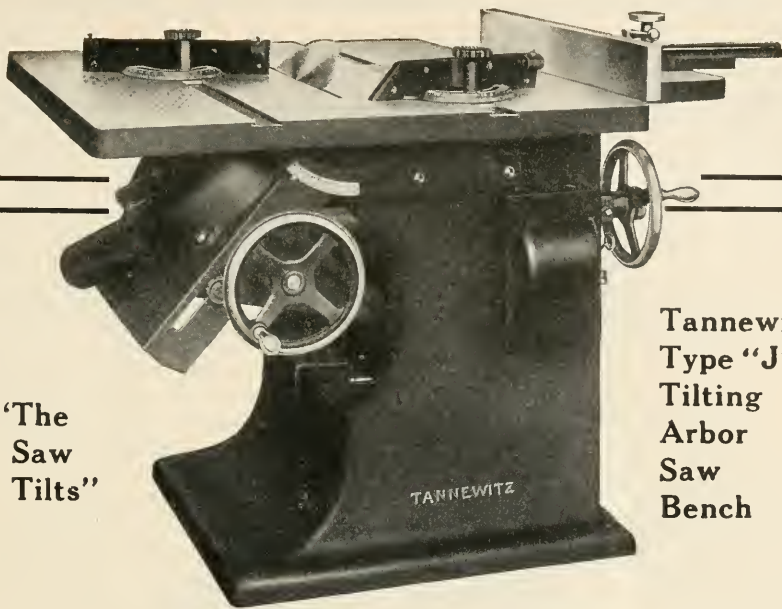

**“The
Saw
Tilts”**

**Tannewitz
Type “J”
Tilting
Arbor
Saw
Bench**

Safety and Service

Tilts the saw to the work, not the work to the saw, keeping table always level. This greatly enlarges working range, and prevents accidents. The safest saw bench you can install.

In addition, the type “J” is equipped with every safety device. Safety switch. Wiring in flexible metal conduits. Curved steel splitter and cage guards; and underneath dust hood with door.

The motor is wound directly on the ball bearing arbor, eliminating intermediate belting, etc., economizing floor space, and increasing safety.

Most convenient bench made. Accurately graduated gauges with taper pins and clamp knob. Left section of table can be made to slide on ball bearings if desired. Saw locks at any angle. Table elevates for accurate grooving.

Try a type “J” free at our expense—our guarantee protects you. Write for full particulars—our reasonable price will surprise you.

The Tannewitz Works

304 North Front Ave.

Grand Rapids, Mich.



FIELD NOTES—(Continued)

in the co-operative plan, emphasizes the feasibility of that school taking care on full time of many of the pupils crowded out of other high schools.

Because of the co-operative plan there are two complete organizations of the upper classes, making possible separate class organization, athletic teams, etc. There are all the usual extra curriculum activities, clubs, etc. Students have the added advantage of being able to earn while learning.

—W. H. DOOLEY.

“MEET ME IN MILWAUKEE IN MID WINTER”

FINAL programs for the eighth annual convention of the Vocational Education Association of the Middle West have just been issued.

This meeting, which will be held on January 11, 12, 13, and 14 next in the Auditorium in Milwaukee, gives promise of even surpassing the high standard already established by previous meetings of this association. The program is particularly well balanced and the program committee of which the president of the association, Prof. J. A. James of the University of Wisconsin is chairman is to be congratulated upon the topics and speakers appearing in the various sessions. The topics on which discussion at present is urgently needed are given a prominent place and will be discussed by people who speak with authority gained from experience. Without doubt—as is usual in conventions of this association—lively discussions will follow, these discussions leading to a clear conception of the work of the public school supervisor and teacher.

Two dinner conferences are scheduled under the direction of the U. S. Bureau of Education. One of these will deal with Industrial Education and the other will deal with Commercial Education. These conferences are always well attended and stimulating in their method of presenting topics under discussion.

The program also shows a goodly proportion of speakers who deal with authority from the standpoint of the employer who makes use of the product of the school. Prominent among this latter group is Arthur E. Morgan, the famous engineer to whom is entrusted the huge project for controlling the flood waters of the Miami at Dayton, Ohio.

In addition to the scheduled general meetings and sectional meetings, the educational forces of the city of Milwaukee are inviting inspection and criticism of their work. To this end, Wednesday, the first day of the convention will be one of great importance to the visiting delegates. Excellent provision has been made for conducting the

visitors to the various schools where work of various types may be inspected. Automobiles will be in readiness to provide rapid transit immediately after registration at headquarters, and ample guides will be on hand to explain every detail. In probably no other city in the country has greater attention been paid to the various forms of vocational education. This includes continuation classes, part time classes, foreman training work, soldier rehabilitation, and the rehabilitation of the industrially handicapped. No one planning to attend the convention can afford to miss this rare opportunity to study under the best conditions the entire range of vocational education problems as worked out in a progressive community.

Final programs may be obtained by addressing the secretary Leonard W. Wahlstrom, 1711 Estes Ave., Chicago. Certainly no one interested in the vocational education movement as it applies to the middle west should fail to obey the slogan and

“MEET ME IN MILWAUKEE”

Reduced Rates on all the railroads have been granted, a fare and a half for the round trip on the certificate plan.

CALIFORNIA FIELD NOTES

WE HAVE in this state several educational institutions, which are designed solely for the benefit of boys and girls who have, through the exhibition of criminal tendencies, become wards of the state by court decree. All of these institutions devote considerable attention to industrial and agricultural training. How much importance is attached to this phase of the work may be gathered from the fact that these institutions are known here as “industrial schools.”

A fair conception of the nature and scope of the industrial arts and agricultural work carried on in the “Industrial schools” was given in a recent statement made by Mr. Otho Close, the superintendent of one of the best known of these schools, the Preston School of Industry. Superintendent Close stated that at present they have at Preston four hundred boys all between the ages of sixteen and twenty-one. To care for these boys the institution employs over one hundred officers including instructors. Every boy is assigned to some regular occupational work. The variety of occupations available for study by the Preston boys may be gathered from the following list of departments maintained by the institution: poultry department, kitchens, print shop, shoe shop, plumbing and sheet-metal shop, horticulture department, blacksmith department, masonry, electrical de-

Extremely Curved Work
Can be Sanded on the



No. 454 "Lightning" Spindle and Disc Sander

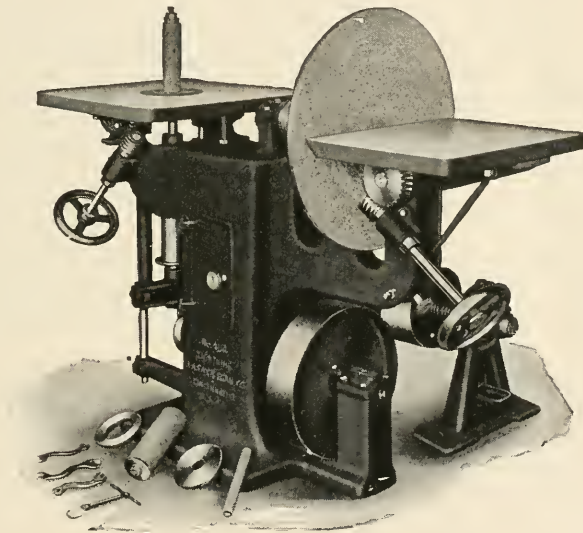

The No. 454 is an ideal Sander for the Manual Training Shop.

Simple and Easy to Operate.

Will sand all kinds of curved, irregular and flat surfaces.
Table angles 45 degrees front and 15 degrees
rear by means of worm and worm segment.

Write today for Bulletin T-6

J. A. FAY & EGAN COMPANY

ESTABLISHED 1830

World's Oldest and Largest Manufacturers
of Woodworking Machinery

730-750 W. Front St.

CINCINNATI, OHIO, U. S. A.



FIELD NOTES—(Continued)

partment, tailor shop, the farm, the mill, the laundry, dairy department, hospital, bakery, and carpentry department. The instructor in each of these departments is in every case an expert in his field. Much of the work, and in some cases, most of the work which the boys do, is on practical jobs needed to be done for the institution. It is the aim of the institution by this means first to find out to what sort of industrial or agricultural work the boy is inclined and perhaps best suited, and then to train him in that work so that he might be able to earn his living at it when he is discharged.

ACTIVITIES IN TULARE COUNTY

During the past year or two Tulare County has been making unusual strides in the field of industrial training. At Woodlake, tho the school serves a rather small community and has perhaps only ninety pupils, a variety of industrial work is offered. It includes auto mechanics, which involves some machine shop work, woodwork of various kinds, and mechanical drawing. All the work is carried on in one building and by one teacher. This building was constructed about a year ago and like several other buildings in small communities of this state, was designed especially for the auto mechanics work.

At Tulare High School there are two main divisions of industrial arts. The woodworking branches are embraced in one division and the automotive in the other. Each Division is in a separate building and under the direction of a special instructor. Up to a year ago woodworking only was offered. This work was and still is conducted in an old building which is also used for the housing of part-time classes for compulsory part-time pupils, and for evening school pupils. The machinery equipment consists of a band-saw, a variety-saw, a jointer and a lathe. It is the intention of the school authorities to remodel the present building so as to convert the main floor into a modern woodshop and make the balconies serve as drafting rooms.

At the opening of the present term this school introduced courses in auto-mechanics. The work is housed in a new building especially constructed for the purpose. F. C. Suiter was engaged for the work. He is a man of wide experience in automotive work, having for a long time been in business for himself; and having previously acted as foreman in large garages first in Los Angeles and later in San Francisco.

This being a union high school, four motor busses are operated in transporting the students. The upkeep of these is one of the practical problems

which Mr. Suiter has incorporated in the auto-mechanics course.

Another place in Tulare County where industrial arts work is attracting attention is Exeter. Here again there is to be found two divisions of the work, the woodwork in the main building and the auto-mechanics in a separate building recently built especially for the purpose. The feature of especial interest in Exeter is Mr. Alltucker's work. He teaches woodwork and mechanical drawing, which up to a short time ago were the only two phases of industrial arts work offered. There are two innovations he is at present trying out which are worthy of special note. The first is his method of teaching carpentry in the high school. The boys who take the carpentry course are second year students. Instead of working on carpentry problems made up to a small scale, the boys are engaged in building real size modern bungalows. The one they are working on now is a six room house. The money for purchasing the material is furnished by the local women's club and they will sell the house when it is completed. This is the second house of its kind on which the Exeter boys worked and they actually do the work, all of it, from mixing the concrete for the foundation to painting and papering the walls. An illustration of Mr. Alltucker's method of dividing up the work is found in his way of getting the rafters cut. After giving a talk on how a rafter is laid out and cut and demonstrating the same, he requires each of the boys to lay-out and cut at least one of the rafters to be used in the building.

A second feature of Mr. Alltucker's work, and one which is particularly unique, is his way of carrying on the manual training in the entire area embraced in the districts contributing to the support of the Exeter school. It is a joint union high school made up of several districts some of which include schools anywhere from six to twelve miles away from the high school building.

For the purpose of serving as many schools as possible, Mr. Alltucker has set himself a regular schedule by which he has arranged to visit a different school each afternoon in the week. As some of the schools are unable to supply all the necessary equipment, Mr. Alltucker carries with him the necessary tools and drawing instruments. And as frequently the desired material is difficult to secure, he also brings that along when necessary.

When he first started this phase of his work Mr. Alltucker naturally found that in certain places suitable quarters were not available. He would then assist in having them built. When necessary he

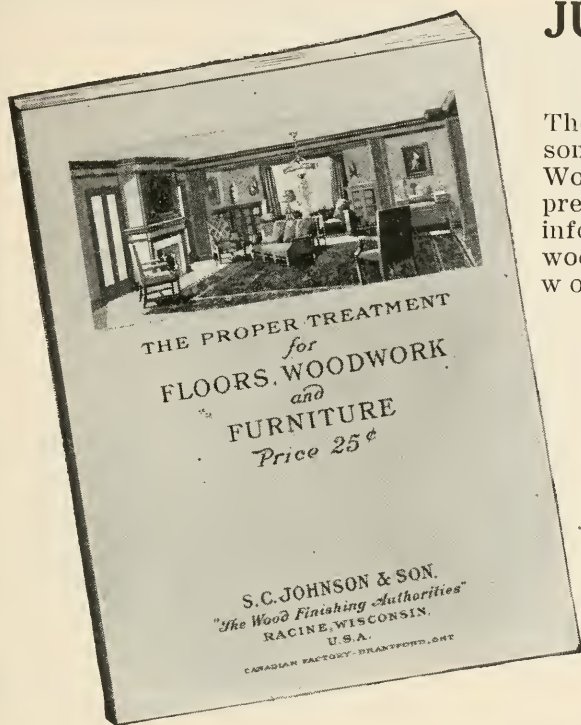

JUST OFF THE PRESS!

The 1922 edition of the Johnson Instruction Book on Wood Finishing is just off the press. It is full of valuable information on finishing all wood—soft and hard. Every wood finishing instructor should have a copy. Considerable space is devoted exclusively to the finishing of manual training models. This book is the work of experts—illustrated in color.

How To Get It FREE

Write us (mentioning the name of the firm from whom you buy paints, varnishes, etc.) and we will gladly send you our book "The Proper Treatment for Floors, Woodwork and Furniture" free and post-paid.

JOHNSON'S ARTISTIC WOOD FINISHES

Johnson's Artistic Wood Finishes are particularly adapted for manual training work as they may be applied by the youngest and most inexperienced pupils with good results. Johnson's Artistic Wood Finishes are standard for manual training—they are being used all over the United States and Canada for this purpose.

The perfection of Johnson's Artistic Wood Finishes has been the work of years. You get the benefit of our experience—of our money expenditure—of our knowledge of woods. Our plant is equipped with up-to-date mills and machinery and every department is in the hands of experts.

Our line of Artistic Wood Finishes is complete—it includes:

Johnson's Prepared Wax

Johnson's Wood Dye

Johnson's Crack Filler

Johnson's Paste Wood Filler

Johnson's Perfectone Undercoat

Johnson's Perfectone Enamel

Johnson's Electric Solvo

Johnson's Varnishes

You will find this entire line described in our book. Any time specific information is desired, or whenever you want specially finished wood panels, do not hesitate to write us. We solicit correspondence with Manual Training Instructors.

S. C. JOHNSON & SON, Dept. MT1, Racine, Wis.

"The Wood Finishing Authorities"



Texts for the new term

These are our best recommendations for the requirements of vocational schools. Check over the list and send for on-approval copies of those of the books that are new to you.

French and Svensen's **Mechanical Drawing for High Schools, \$1.50.**

French and Turnbull's **Lessons in Lettering.** Book I, Vertical, 35 cents each; per doz., \$3.60. Book II, Slant, 35 cents each; per doz., \$3.60.

Longfield's **Sheet Metal Drafting, \$2.25.**

Palmer's **Practical Mathematics.** Part I, Arithmetic with Applications, \$1.25. Part II, Geometry with Applications, \$1.25. Part III, Algebra with Applications, \$1.25. Part IV, Trigonometry and Logarithms, \$1.25.

Croft's **Practical Electricity, \$3.00.**

Rowland's **Applied Electricity for Practical Men, \$2.50.**

Hobbs, Elliott and Consoliver's **Gasoline Automobile, \$3.00.**

Moyer's **Gasoline Automobile, \$2.00.**

Burghardt's **The Lathe, Benchwork and Work at the Forge, \$2.25.**

Colvin and Stanley's **American Machinists' Handbook, \$4.00.**

Seaton's **Concrete Construction for Rural Communities, \$2.25.**

FREE EXAMINATION COUPON

McGRAW-HILL BOOK CO., Inc.
370 Seventh Ave., New York

You may send me on 10 days' approval

.....
.....

I agree to pay for the books or return them, postpaid, within 10 days of receipt.

Signed

School

Official Position

Address

M. T. M. 1-1-22

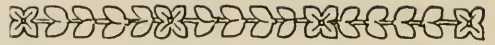

FIELD NOTES—(Continued)

also helped in the making of benches. The manual training in the district schools is given to seventh and eighth grade pupils only.

—CHARLES L. JACOBS.

FROM THE SOUTHWEST

THE INDUSTRIAL Arts teachers of Texas met in Dallas November 25 in connection with the State Teacher's Association. Quite an extensive program had been prepared. When it was announced that Dr. Prosser of Dunwoody would be able to be with the Industrial Arts Teachers, a number on the program urged that he be requested to use their time. Dr. Prosser gave several splendid lectures.

At the noon hour a luncheon was served on the roof garden of the Adolphus Hotel. At this meeting a State Vocational Association was perfected to be closely associated with the national association. Miss Jessie Harris of the State Department of Education was elected president.

At a business meeting of Industrial Arts teachers, Mr. J. W. Fox, Director of Vocational education of the San Antonio schools was elected chairman for the following year.

The Texas Vocational Progress, a monthly paper published by the Texas State Board for Vocational Education, made its debut in November. It will be issued about the fifteenth of each month. It is a co-operative news letter belonging not only to the State Board for Vocational Education, but also to the teacher-training institutions and to the teachers in the field as well.

It is an interesting little sheet and will no doubt prove a great help to the teachers receiving it.

News has been received of the winning of first honors by three Texas vocational agriculture boys in the Stock Judging Contest of the Southern Region held at State Fair, Macon, Georgia, November 1 and 2, 1921. Sixteen states were represented in the contest.

The Annual State Conference of Teachers of Vocational Agriculture met in Waco, October 7th and 8th. Eighty-two out of a total of eighty-eight white teachers were present.

Addresses were made by the following: Miss Annie Webb Blanton, Dr. W. B. Bizzell, Dr. S. P. Brooks of Baylor University; E. B. Mathews, State Supervisor of Agriculture of Arkansas; Dr. Wm. E. Garnett and M. L. Hayes, of A. & M. College; S. C. Wilson, Huntsville; L. W. Rogers and N. S. Hunsdon, of the Department of Education.

A conference was held in Austin during the last



The superior accuracy and quality of Starrett Tools is shown by the fact that toolmakers as a class prefer them. These men know the importance of using precision tools of the highest accuracy. The worth of Starrett Tools to men of lesser skill is even greater—because they need the aid that only fine tools can give.

*Write for free copy of Starrett Catalog No. 22 "EF",
describing and illustrating 2100 fine tools.*

THE L. S. STARRETT COMPANY

*The World's Greatest Toolmakers
Manufacturers of Hack Saws Unexcelled*
ANTHOL, MASS.



Starrett Tools

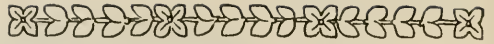

FIELD NOTES—(Continued)



Kewaunee

Manual Training Furniture

Kewaunee equipment appeals to educational authorities because we incorporate in every piece the most scientific and practical design, the best materials for the purpose and the unusually fine workmanship which marks all Kewaunee Equipment.

Aside from the influence upon your teachers and students, Manual Training Equipment of superior quality and attractive appearance is a good advertisement for your school. Why should not a school give as much thought to the quality of its equipment and the appearance of its work rooms as a modern manufacturer?

Educational Executives who are considering new equipment will find much of interest in the Kewaunee Book. Write for it. No charge.

Address all inquiries to the factory at Kewaunee

Kewaunee Mfg. Co.
LABORATORY FURNITURE EXPERTS

111 Lincoln St.

KEWAUNEE, WIS.

New York Office, 70 Fifth Avenue

BRANCH OFFICES:

Denver	Spokane	Los Angeles
Phoenix	Columbus	Jackson, Miss.
Chicago	Little Rock	Toronto, Can.
Atlanta	Minneapolis	Alexandria, La.
Houston	Kansas City	Oklahoma City



Manual Training Bench No. 1904
Has accommodations for three students.

week in October to discuss and make plans for further progress in vocational home economics in Texas. The college of Industrial Arts was represented by Miss Joan Hamilton; the University of Texas was represented by Miss Bess Heflin, and Miss Virginia Shearer; the Southwest Texas Normal College was represented by Mrs. Clara B. McConnel. Miss Lillian Peek and Miss Jessie Harris represented the State Board for Vocational Education. The program for the State conference was formulated and plans were made for further extending help from the teacher-training institutions to the teachers in the field.

—E. A. FUNKHAUSER.

BOOSTING

FOREST PRODUCTS LABORATORY

THE VALUABLE work done by the Forest Products Laboratory, Madison, Wisconsin, has appealed to the Association of Wood Using Industries, with headquarters at Chicago, to the extent that this association is strongly recommending an increase in the annual appropriation for the Laboratory from \$75,000 to \$100,000. It is pointed out that there is now a great deal of information resulting from experimental work at this government institution which has not been organized and made available for the industries because of lack of funds.

FROM NEW JERSEY

ESSEX COUNTY ARTS ASSOCIATION

The Essex County Arts Association held its November Round Table Meeting at the Central High School, Newark, New Jersey, November 9th, 1921.

In the Industrial Arts Section of this meeting, of which Federick R. Price is chairman, Arthur Hopper made a talk on "A Review of the Present Day Tendencies in Manual Arts."

The Vocational Section, presided over by H. H. Fuller, discussed the topics "Shop Mathematics for the Machine Department;" "The Progress of Vocational Education;" and "The Disposition of Vocational School Products." The respective leaders for these topics were F. J. Fisher, Sheldon W. Parker, and John A. McCarthy.

WILLIAMSPORT, PENNSYLVANIA

A day trade course in electricity has been added to the industrial courses offered by the public schools of the city of Williamsport, Pa. The shop instructor in electricity is Mr. Charles O. Kaupp a graduate of Pennsylvania State College in Electrical Engineering who has served an apprenticeship with the General Electric Co.

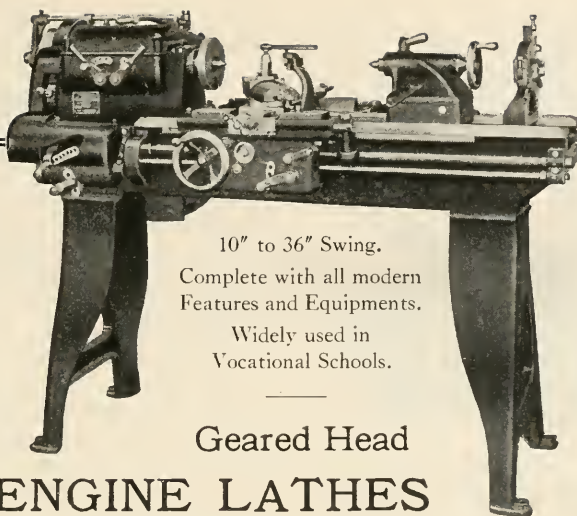

10" to 36" Swing,
Complete with all modern
Features and Equipments.
Widely used in
Vocational Schools.

Geared Head ENGINE LATHES

BUILT ESPECIALLY FOR SCHOOLS

And a Complete Line of
WOODWORKING MACHINERY

Including the "FAMOUS 30" UNIVERSAL WOODWORKER

Write for Interesting Descriptive Matter

THE SIDNEY MACHINE TOOL CO. SIDNEY, OHIO

RIGHTLY NAMED

We have recently mailed our SEVENTH ANNUAL CATALOG OF "HARD-TO-GET" MATERIALS to schools in all parts of the Country. In response many Instructors have written us that this catalog is most rightly named as it lists a large number of items impossible to obtain from the usual sources. This latest catalog of Cabinet Hardware, Furniture Fittings, Upholstery Supplies, etc., will be mailed promptly to any instructor.

CHEST TRIMMINGS

Solid Copper Bands and Fancy Designs, Coppered Nails, Locks, Handles, Hinges, Cover Supports. Also Chest Corners, Edge Binding, Hinge Plates and Handles in Hammered Old Copper Effect. Casters and Sliding Devices in various styles and sizes.

Dennison Glue Stanley Tools Johnson Stains

THURSTON MANUAL TRAINING SUPPLY COMPANY

Jobbers and Manufacturers

Anoka, Minnesota



The Best of the Better SAWS

When arranging to add new or additional equipment to your manual training or vocational departments select the best saws--SIMONDS. They stand hard usage and hold their cutting edge. Get Simonds Hand Saws, Back Saws, Coping Saws and Hack Saws.

Write for Catalog and Prices



SIMONDS
Manufacturing Co.
"The Saw Makers"
 Fitchburg, Mass.

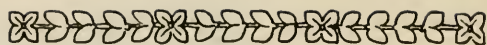

FIELD NOTES—(Continued)

The enrollment in the night courses this year is unusually heavy and trade extension classes for men are practically filled. The following subjects are being taught: Mechanical Drawing, Machine Design, Electricity, Automobiles, Carpentry, Acetylene Welding, Furniture Drafting and Rod Making, Machine Shop Practice, Industrial Chemistry, and Shop Arithmetic.

Courses for women in Millinery, Cooking, Sewing, Home Nursing, and Dressmaking have been started and in some courses the enrollment has been so large that classes have been divided into two sections.

—ALLEN D. BACKUS.

OCCUPATIONAL THERAPY CONVENTION

THE FIFTH annual meeting of the National Society for the Promotion of Occupational Therapy was held in Baltimore, Maryland, October 20-22. The results of the accomplishments in this relatively new field of endeavor were reviewed by a number of those who have been particularly successful in developing effective means and methods for dealing with the patients who come under this division of hospital work.

Some of the topics which indicate the subjects discussed during this convention were: "Experience with the War—Blinded in Their Readjustment to the Loss of Sight," by Chas. F. Campbell; "The Psychology of Occupational Therapy," by Miss Ethel Bowman; "Is Diversional Occupation Always Therapeutic?" by Louis J. Haas; and "The Industrial Case, from the Accident Back to the Job," by Miss Hilda B. Goodman.

GOVERNMENT ESTABLISHES VOCATIONAL CENTER

WITH AN initial enrollment of 500 students the first big Government vocational training center established by the U. S. Veterans' Bureau was opened December 2, at Chillicothe, Ohio. Col. Charles R. Forbes, director of the bureau, and sponsor of the government training centers left Washington Nov. 30 to direct personally the opening of the school, which is known as the U. S. Veterans' Bureau Vocational School.

Students attending the school have been selected from the eastern and central states, and it is planned to have an ultimate enrollment of 5000 at the school. Every modern appliance has been installed to care properly for the vocationally disabled veteran. A large hospital, complete in every respect; high class community houses, which were used during the war as Hostess' Houses; a large laundry, completely equipped and running; and many other features have been inaugurated by Col. Forbes.

Manual Training Magazine

JANUARY, 1922

THE STUDENT FACTOR IN SMITH-HUGHES EDUCATION

FRANK C. VINCENT

Supervisor of Industrial Education, Vallejo, California

FOUR years have passed since the Smith-Hughes Act was put into force. Successes and failures in the administration of the courses under this act have brought to light a number of interesting experiences in various schools.

Imagine the writer's surprise when he heard the vice-principal of a technical high school remark in a vocational conference of administrators that in his school, numbering about 3,000 students, "fourteen per cent of all the discipline came from the two per cent of Smith-Hughes students." Another school man from another state in speaking of his experience with Smith-Hughes work said, "We tried it in agriculture but it failed. Half the time of the boys was spent in the school and the other half on the farms. We soon had the worst knockers and kickers the school had known, but all the 'rough necks' were enrolled in that course." Still another city boasts of a vocational school that has maintained Smith-Hughes classes. The policy of the administration has been to enroll in such classes those boys who were too slow and unruly in their regular work to make any progress. The idea prevailed that if they could not succeed elsewhere the Smith-Hughes classes would be "just the thing for what ailed them," to use a homely expression. The results were not satisfactory.

Another technical high school in still another state has about 250 boys enrolled in vocational classes which have

all the characteristics of Smith-Hughes work, but not under Federal supervision. In reply to an inquiry relative to the type of students enrolled in these classes the principal was quick to report that boys must prove themselves capable in their regular work before being admitted to the special vocational classes. His is one of the really successful schools in the country.

A supervisor, administering successful vocational work in a large city confided that when the superintendents forced him to enroll in his Smith-Hughes classes the students under discipline from other schools his task was fruitless, hopeless, and thankless.

The student is the product by which we gage the success or failure of a Smith-Hughes course. We cannot produce a quarter-sawed oak table by using chestnut or ash. In other words, to have a genuine product we must have the proper raw materials. The public has always paid the price demanded for the genuine product, properly finished. The public has been deceived at times when substitutes have been passed as genuine, but the bitter disappointments of the purchasers never added confidence in those who misrepresented their products.

A school was conducting a class in Smith-Hughes carpentry. The class was composed of boys whom the grade principals from over the city had no more use for. They were under sized, young, aimless, and uninterested. The carpentry

projects were school furniture of cheap quality. It goes without saying that the public was being sold a substitute under a genuine label.

Has not the idea that manual training, industrial training, vocational education, etc., are panaceas for the educational ills of the backward and retarded youngsters, fourteen, fifteen, and sixteen years of age, gone a little too far? It is probably true that somewhere there is a teacher of the right personality to appeal to and induce effort from any student, but it is seldom possible to find one personality that will appeal to every student in a class of pupils of normal ability, and much less possible a class picked from over the city by the distracted principals.

Let us wipe enthusiasm and prejudice concerning Smith-Hughes vocational education from our minds, and look at the picture it presents in the proper perspective. We see the local supervisors and other administrators of the school system running an educational factory; we see the groups of boys and girls at work in their courses; we see the Federal and state supervisors encouraging the local supervisors and suggesting improvements as far as they dare suggest, and at the same time making as favorable reports as they can to Washington, D. C. in order to create as good an impression as possible for the particular district or state; we see the mounting costs of this system which, under Federal supervision, have, in every instance noted by the writer, cost the local district an additional sum which was not equalled by the Federal appropriations; we see an apathetic public paying the costs, at the same time pulling the purse strings tighter each day; we see the ranks of labor and employers in industry watching the experiment and wondering just how soon its effect will be felt among them; we see another group which should be mentioned—grand-

stands full of educators watching the progress.

The highlights in this picture are the students at work, the mounting cost of education, the apathetic public closing its purse, and industry. Knowing, as we do, the life of the people in this picture we can see that the apathetic public is paying the costs of manufacture and transportation of the student product to the employers in industry. Just as soon as industry tests the product and finds its materials are inferior, just so quickly will the financial support of the burdened educational factory be cut off. In other words, the product of the Smith-Hughes Act must stand the acid test of industry or the benefits of the act will be withdrawn.

The writer has been fortunate enough in his teaching and supervision of Smith-Hughes subjects ever since the act was put in force, to be able to select the student material for his classes. In no instance where students were forced or persuaded to pursue a course which was distasteful or uninteresting to them has the course been a success from the standpoint of the ultimate consumer in industry or from the standpoint of the costs entailed. The most successful Smith-Hughes work was done only after the boys had attained the age of 16, which was the minimum age of entrance, and when a premium was placed upon ability. There are many bright boys and girls in every community who want the best education that the schools can afford and who do not expect to go to college. They have a modest pride in their own ability. Given a proper incentive, they will avail themselves of the Smith-Hughes courses, provided the ultimate objective is an inducement. They are the ones who are genuine raw materials; who will take a good finish; and who will stand the test and scrutiny of

industry. It was noted that the ambitious students will not voluntarily enroll in a vocational class of those sentenced to the work, nor will they remain long in such a class doing creditable work under such conditions. The class for the most part must be genuine or the product is a disappointment.

The writer does not wish to be understood as saying that the backward and retarded students should not be given a chance at some kind of industrial education—far from it. As they will get little education beyond what the law requires, they will not be any too well equipped to manage for themselves and will go into industry as unskilled workers. Whatever contact with industrial education they get in the schools should make them better workman than they would otherwise be. But should they be permitted in the Smith-Hughes courses? If they are not genuine raw materials and are permitted to put in their time and receive

even failing grades there is no way to dispose of them or their experience as we might dispose of pieces of discarded furniture. They will go into industry and ask for jobs on the strength of having pursued certain Smith-Hughes courses in certain schools at certain times. Their school experience will sound well to the employers; and the employer is the exception who will call up the school to check the records. On the strength of this alleged education the employers have a right to expect more than they will get. The schools will be criticized and financial aid will be more difficult to obtain.

This would all sound like a false alarm were it not for the fact that the desire to use substitute materials in Smith-Hughes classes is, even yet, irresistible. The substitute material should be worked up, but should it go into a costly product which cannot live up to its reputation? By what standards should we gage this work?

SCHOOL SHOP ACCIDENTS AND THEIR PREVENTION

E. E. ERICSON

NOT long ago I became acquainted with a young man who was employed as an office worker. I noticed that he had lost a part of the first finger on his right hand. I asked him, "How did you lose your finger?" The answer came quickly, and without any of the air of a martyr, "In the school shop. Took advanced cabinet making in the high school. Slipped into the jointer." This man is only one of a goodly number of young men who bear the marks of "hard luck," carelessness, or what not, from the high school shop where power machines are used. His attitude of mind was also typical of these fellows; they take it as they do a broken nose on the football field, or a broken finger in baseball.

ARE THERE TOO MANY ACCIDENTS?

Accidents may be unavoidable and may be considered as a necessary evil accompanying power machinery in the high-school shop. But no one will deny that the number of accidents—altho not now appalling—can be reduced here just as accidents incidental to automobile traffic can be reduced and have been reduced in many places. It might well be stated, after considering the matter from different angles, that there are too many accidents in the school shop; also that the question of possible accidents which maim for life should be an important one with the teacher and is now an important one with the parents who in most cases influence the selection of the studies for boys of high school ages.

Further, it may well be assumed that to the extent that accidents are avoided, the department of industrial training will be in position to render service to a larger number of boys, particularly the class of boys who take the work as a general study in their academic course.

REDUCING ACCIDENTS

While realizing that accidents occur in the school shop and sometimes serious ones, no one would consider the best remedy to be the elimination of power machinery any more than he would advocate the elimination of the art of swimming because of the accidents which occur in connection with this sport, or the abandonment of the automobile because of accidents which may occur in connection with its use. But every board of education and every teacher should be willing to do what is in their power to reduce accidents to a minimum. And the minimum can be a very insignificant figure if proper means are pursued.

CAUSES OF ACCIDENTS

What are, then, the causes of unnecessary accidents in the school shop? The most of them can, perhaps, be enumerated by any teacher if he stops to make an analysis of them. In general it may be said that these causes can be classified under two heads, (1) a carelessly equipped shop and, (2) careless shop teaching.

A CARELESSLY EQUIPPED SHOP

In a carelessly equipped and maintained shop, the following dangerous conditions are likely to prevail: (a) uncovered line shafts on the floor with collars and set screws particularly dangerous to the workers; (b) unguarded belts so located that students are in constant danger of coming in contact with them; (c) unguarded machines particularly those that do woodwork; (d) dull and badly fitted woodworking machinery; (e) lumber and waste wood lying about on

the floor of the shop and; (f) poor arrangement of machines and equipment which fails to allow proper working space for each machine and which throws the student working at one machine in danger of being interfered with by the operator of another.

CARELESS SHOP TEACHING

It is not easy, even tho it might be very profitable, to determine whether faulty equipment or faulty shop teaching is responsible for the larger number of unnecessary injuries in the school shop. It may make little difference to the student in after years whether his loss of one or two fingers was due to one reason or the other. To the teacher, however, it should make a tremendous difference which of the two causes contributed to a certain accident. There is no doubt but that the poor shop teaching that some men—consciously or unconsciously—practice, is the cause of grave accidents. This is not a kind statement perhaps, but we may as well look at conditions as they are, for only in this way shall we be able to get the viewpoint which will cause us to change them.

If we will stop again and make somewhat of an analysis—this time of the points in poor shop teaching that are nothing short of being criminal in that they expose the young student to avoidable dangers, we will find the following to stand out: (a) failure to make explanations of the operation of machines—in other words, to teach point for point the proper uses to which the machine may be put; (b) failure to follow up explanations and demonstrations to see that the boys practice the correct methods of working, and to see if the information that was given out became part of the student's working knowledge; (c) poor discipline generally—the students using the shop for a play-house; (d) overtime work without proper supervision; and (e)

allowing experimentation by the boys in the use of machines.

CAN ACCIDENTS BE PREVENTED?

If it may be assumed at this point that the causes for shop accidents have been analyzed somewhat correctly, and that they may be divided under the two general headings, carelessly equipped shop, and careless teaching, it is self-evident where one might set to work to diminish the danger to the students in the school shop or perhaps eliminate entirely all major accidents from the shop. A conviction regarding these conditions will not change the status of things however; it will require some definite action on the teacher's part.

PUTTING EQUIPMENT IN ORDER

In the first place, if these causes are to be reduced or eliminated, the question of a thoro overhauling of machines once each year is likely to suggest itself. This again, involves the question whether the teacher can manage to receive an invitation to stay at least one month during the summer for the purpose of putting the shop in order for the coming year. Where the teacher's salary ends with the commencement program in the spring and begins with the first teachers' meeting or with the teachers' institute in the fall he can not be expected to have the equipment in tip-top shape for the new school year. There are, of course, some teachers—pillars of the teaching profession they are—who will not allow poor conditions to prevail in the shop for any reason, but who will arrive on the job earlier than they are called for by their contract or who will increase the length of their working day in order to be able to give their students a fair chance in their shop. In fairness to everyone concerned, it should be stated, however, that there is an increasing number of schoolboards which employ manual arts teachers for the summer for the kind of

work discussed here as well as for other lines in which this type of teacher has proved himself useful. If the shop teacher is employed at his school during the summer, he should not fail to apply part of his energy to the reasonable demands of his equipment for the coming year. A few days of labor well applied to the equipment during the vacation will save much time and will eliminate many unpleasant experiences during the coming year.

Another thing which necessarily is called to one's mind in this connection is the frequent sharpening of knives and saws, particularly of woodworking machinery. The cause of a large part of all accidents in the school shop can be traced back to dull machinery. Anyone who has tried to cut a short piece of hard wood on a dull jointer will feel the truth of the statement that dull wood working machines are extremely dangerous. It takes time to keep a number of machines sharp. This work can't be done during vacation; there must be an allotment of time in the schedule for it. Sometimes much of it has to be done outside of schedule, but the significant thing in this connection is that *it must be done* and must be done regularly.

As suggested above, the lack of a definite place for pieces of scrap stock is a constant source of danger in the shop. One might well go so far as to judge the safety of the shop and its state of organization by the presence or absence of the scrap-stock rack. Where the strips and waste pieces produced are dropped by the machines and allowed to lie there, a constant trap is set for the student who moves about in the shop.

Two or three other suggestions may be valuable in this connection. They are applicable mainly in connection with new installations or in rearranging the equipment. First, in a school shop practically

all machinery can be made less dangerous if direct motor drive is used than where line shafting has to be resorted to. There may be other good arguments for the direct motor drive, but this is one which should be considered. Particularly is this true in connection with woodworking machines. Unless a line shaft can be put under the floor it will prove an obstruction which involves danger in several ways. Secondly, the machines should be so connected electrically that anyone of them may be shut off in a private room or cabinet, the entrance of which the instructor controls. This will make it possible to disconnect a machine which is too dull or which is otherwise unfit for use until it is again put into first class condition. This alone will eliminate many accidents, for it should be remembered that it is when machines are unfit that accidents are most likely to occur. There is not a great deal of expense connected, as a rule, with changing the wiring in any shop to obtain this condition; the effort necessary will prove to be worth while in time.

BETTER SHOP TEACHING AND DISCIPLINE

In giving instructions to high school boys concerning the use of machines it is necessary to remember that they are used to hearing of many rules and regulations. This does not mean that they are in the habit of being governed by them. On the contrary, they are most likely to be fairly expert in evading rules and "getting by." For this reason it will be of little use to make a few broadcast rules for the use of the machines in the shop and expect the students to follow them. Unless they have a thoro understanding of the purpose of the rules for their conduct in the use of machines, they are most likely to take the same attitude toward these rules as they have toward a number of those pertaining to general behavior around the premises of the

school. They must feel a sense of self-government while they are working in the shop. It is absolutely necessary that the teacher get their co-operation and that they feel the responsibility of the outcome of their action while at work with the machines. It is the attitude of mind that prompts the student to violate rules and try to "get by" that plays havoc with the limbs of high school boys.

In my experience it has proved valuable to take strong measures toward impressing the boys with the fact that (1) the "safety first" rules of the shop are not man-made, and (2) that the established methods of procedure carry with them the best safety rules. To accomplish this I have used suggestions to the class that may be of interest to other teachers. I have presented the matter in language somewhat as follows:

"You boys are accustomed to hearing of many rules and regulations. There are rules for your conduct in class, for your behavior in the assembly hall, for your actions on the school grounds. Whether or not you will be penalized for violations of these rules depends, first, upon whether you are caught in the act of disobeying, and secondly, upon what kind of talk you can put up to the teacher if you are caught. The general rules of the school are flexible; they are applied according to the temperament of the persons who made them.

"But in the shop where power machinery is used the condition is entirely different. The most important rules here are not made by man. Each machine has its own set of rules. The jointer says: 'if you put your finger into the knives when they are running you will have them cut off.' And the tragic part of the thing is that it never fails to apply this rule. It will not be caught turning its back or looking the other way while the student breaks a rule and 'gets by'

with it. The rip-saw, the band-saw, and all the rest of the machines have similar rules and they never fail to enforce them, The electric power at the switch is never asleep on its job. It will not consider the inexperience of the beginner and take pity on him to the extent that it will fail to deliver a shock because the student didn't know better. The machines will not modify the punishment according to the conditions that prompted the student to disobey their rules. It may be considered good sport by some boys to violate rules when no one is looking. This experiment had better not be tried with the power machines."

After this sort of consideration the students are usually willing to listen to a lesson on the correct method of handling the machines. If the boys are brought to see that the definite demonstration is for their safety and efficiency, they will capitalize it to the utmost. It is the proper attitude of mind that counts toward the elimination of accidents among students. The success or failure of the first lesson in the use of machines may largely be taken as an index to what is going to occur in the shop during the year. It may take many lessons before the teacher arrives at what he considers the ideal condition, but a beginning toward this ideal must be made at once when the class is started. After the class has run wild for a season it is a hard matter to bring about individual responsibility.

DANGER THRU FEAR

It may be possible to go so far in cautioning the student against the danger of the machines that their initiative and efficiency would be much inhibited thru fear of being hurt. If this is likely to be the condition, it may be removed by some suggestions pointing out the fact that the machines are just as punctual in not overstepping their proper function as

they are in enforcing their laws of action, and that no danger is present as long as the student will do the proper thing. Some skillful demonstrations by the teacher will do much to eliminate such fear and will soon get the student to the point where he enjoys the work on the machines. Some students require considerable attention before they can be made to feel at ease while using the machines. A large job of ripping, planing, or band-sawing, turned over to a student of this type will often prove to give him enough practice to release his mind from its cramped condition. Too much stress cannot be laid on this principle, for as long as the student is in a state of fear he will not enjoy his work, will not become efficient, and is in danger of causing injury both to himself and others. A sympathetic understanding between students and teacher is always essential to the kind of morale in the shop that will keep accidents away.

OVERTIME WORK

During my experience of eight years as a teacher of classes using machinery, two accidents occurred. One student had his first finger on the right hand cut off to the first joint; the other was hurt from a loose knot thrown back by the rip-saw. Both of these accidents happened in the first two years of my teaching; and both happened during after-school hours when I was not in the shop. These experiences taught me a lesson. Since the second accident I have not allowed overtime work involving the use of machines unless the teacher could be supervising it in the same sense as he would during regular class hours. Since that time there occurred no further accident in my classes, and were it not for the two mentioned, my conscience would be entirely clear regarding my duty toward students doing work on dangerous machinery. I believe that had I not allowed overtime work

without close supervision the two accidents mentioned would not have happened. One was caused by a student trying to joint the flat side of a very short piece of lumber; in the other case, I should very likely have noticed the student working with a board which needed attention before it was put over the saw. One might, further, see traces of poor shop teaching in this report. In my later teaching, I believe all my students knew better than to try either one of the "stunts" referred to, after I had presented the first two or three lessons on the use of machines.

THE TEACHER'S RESPONSIBILITY

In the last analysis, while the legal responsibility upon the teacher for accidents may be light, his moral respon-

sibility is heavy. No conscientious teacher can rid himself of this charge. The students are put in his care. When accidents occur he may have convincing arguments to show that the student was at fault. And in most cases the student is at fault. But silently comes to the teacher the vision of things that might have been done differently. If they had, perhaps the accidents could have been avoided. And so the honest, well-meaning teacher goes home with a determination to better protect the students from possible injury in the shop. But of greater value than the prevention of a recurrence of an accident, is the application of ones effort toward the absolute safety of the shop to the end that the first accident shall not occur.



A SHEET-METAL SHOP CONVENIENCE DESIGNED
BY CHARLES ABERG.

SHEET-METAL WORK FOR JUNIOR HIGH SCHOOLS

CHARLES ABERG



ABOUT a year ago we invited Mr. Aberg, then instructor in sheet-metal work at the Seward Junior High School, Minneapolis, to contribute a series of articles to this Magazine. This invitation was extended to him because his course and the methods he employed seemed to be especially adapted to the needs of classes of junior high school students. He had gone somewhat out of the usual realm of sheet-metal courses and had included practical problems in heavy metal, some work in copper and especially work in finishing sheet-metal with enamel paint, which gave opportunity for correlation with the department of freehand drawing and design. On the side of methods, Mr. Aberg has adapted the sloyd training he received in Sweden to excellent purpose. His classes were well taught and his shop was a model of "good housekeeping." His work seemed to strike a new note in the sheet-metal field.

Not long after we solicited the article Mr. Aberg died of pneumonia, having written only the first draft of the first article of his series. We give this below. It is sufficient to set forth his fundamental scheme, tho many important details are lacking. Later, we will publish a brief article by Miss F. M. Guenther, the teacher of drawing, who co-operated with Mr. Aberg. Her article will discuss the designing of the painted decorations used on several of the objects made in the sheet-metal classes.

—THE EDITORS.

WHEN the junior high schools were organized in Minneapolis five years ago, sheet-metal was one of the try-out courses to be installed. I was one of the two manual training teachers in the force selected to organize the work. I had had some scattered experience in the sheet-metal line, and this was supplemented at that time by courses in sheet-metal work and drafting at Dunwoody Institute. Additional practical experience was obtained while working in a sheet-metal shop during the following summers. My fifteen years' experience as a wood-work and mechanical drawing teacher gave me an educational foundation on which to build.

The more I studied the educational value of the sheet-metal work, the more important I found it to be as a try-out subject for junior high school boys. Its

pre-vocational and vocational values make it an almost indispensable subject in any vocational or senior high school course.

The cost of equipment is comparatively small. Before the war a complete equipment for a class of twenty pupils could be installed for about \$500. More hand machines and tools are included in this equipment than in any other branch of metalwork.

Skill in handling a great variety of tools is developed. The machines are all hand operated. They must, therefore, be entirely under the control of the pupil. The operator's mind must be on his work at all times if the desired results are to be obtained, and his mental development corresponds to his power of concentration.

We had poor start on account of being limited to a "productive shop" which, in

COURSE OF STUDY FOR SEWARD JUNIOR HIGH SCHOOL SHEET-METAL DEPT.	PROCESSES																					
	1. Laying out of simple patterns	2. Cutting with handshears	3. Folding in machine	4. Forming by hand	5. Soldering	6. Using the cornice brake	7. Lapping and soldering corners	8. Turning for wire in machine	9. Wiring	10. Forming in machine	11. Laying out from a pattern	12. Turning a curved edge for wire	13. Double-seaming	14. Grooving by hand	15. Laying out of complex patterns	16. Countersinking by hand	17. Punched seam	18. Double-seaming corners	19. Using the hollow punch	20. Making a hinged top	21. Cutting in the squaring-shears	22. Punching
PRODUCTS																						
A. Cookie-cutters	X	X	X	X	X																	
B. Box with lapped corners	1	2	3	4	5	X	X															
C. Round cookie-cutters	1	2	3		5			X	X	X												
D. Funnel		2	3	4	5				9		X	X	X	X								
E. Match-box		2	3			6								13		X	X	X				
F. Box with double-seam corners		2	3			6		8	9			12			15				X			
G. Mail-box		2	3	4		6									15		17		X	X	X	
H. Dust-pan	1	2	3	4	5	6		8	9		11				15							X
I. Boston bread steamer		2	3		5					10				13								
J. Round pan with wired edge	1	2	3		5			8	9	10			13	14	15							21
K. Dipper		2	3	4	5				9	10	11	12	13	14		16						
L. Strainer		2	3	4	5				9	10	11	12	13	14								
M. Lunch or fishing-tackle box		2	3		5	6	7								15				18			21 22
N. Wastepaper can		2	3		5				9	10		12	13	14		16						21
O. Coffee can or paraffin melter	1	2	3	4	5				9	10			13	14								21 22
P. Bread-tins		2		4				8	9	10			13	14								
Q. Tinsmith's tool-box		2	3	4	5	6		8	9	10	11				15				18			21 22
R. Pail, dish-pan or garbage can		2	3		5			8	9	10	11	12	13	14	15							21 22
S. Coal-bucket		2	3	4	5				9		11	12	13	14								21 22
T. Sprinkling can	1	2	3	4	5						11		13	14					19			21 22
U. Sprayer	1	2	3	4	5					10	11		13	14					19			21 22
V. Stovepipes		2	3							10			13	14								21
W. Elbows		2	3							10	11		13									21 22
X. T's		2	3							10	11		13	14								21 22

SHOP KNOWLEDGE

SHOP MATHEMATICS

Repairing utensils. Filing. Use of hack-saw. Use of post-drill. Use of screw-plate. Fluxes. How to prepare cut acid. Tinning of copperbit. Solder and other alloys. Metals. Galvanizing. Manufacturing of tins-plates. Tools—their care and use. Machines—their care and use. Visits to outside shops. Opportunities in the sheet-metal trade.

Calculating the quantity and the cost of the material needed for the various projects gives the pupil practical mathematical problems. A special course in shop mathematics is also given.

24. Riveting																				
25. Using the circular shears	X	X																		
26. Folding a curved edge	X																			
27. Burring	X																			
28. Setting down in machine	X																			
29. Laying out of cone-shaped patterns																				
30. Setting down by hand																				
31. Double-seaming bottom in machine																				
32. Double-seaming bottom by hand																				
33. Making hinges																				
34. Using the beading machine																				
35. Turning convex curve for wire																				
36. Laying out a cone-shaped pattern in two pieces																				
37. Beading in a bottom																				
38. Laying out of a lip pattern																				
39. Laying out pattern for solid corner																				
40. Using the hand swage																				
41. Laying out pattern for a mitered corner																				
42. Making a hasp																				
43. Using the cold chisel																				
44. Grooving in machine																				
45. Using the post-drill																				
46. Triangulation																				
47. Laying out pattern for a spout																				
48. Laying out pattern for an oblique cone																				
49. Laying out pattern for a stove-pipe																				
50. Using the crimping machine																				
51. Laying out patterns for elbows																				
52. Laying out patterns for T's																				

<p>SHOP SPELLING 1 pupils are required to spell correctly names of machines, tools, materials, processes, etc.</p>	<p>DRAWING Every pattern laid out is a drawing problem; sketches are made by the pupils, of most of the problems in the shop. In addition an extensive course in mechanical drawing is given.</p>	<p>PROGRAM 300 min. a week for shopwork. 20 min. a week for shop spelling. 40 min. a week for shop mathematics. 80 min. a week for mechanical drawing.</p>
--	---	---

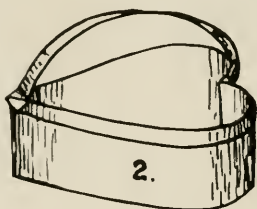
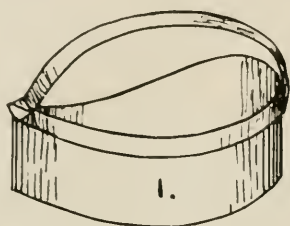

COOKIE CUTTERS N^o 1

SCALE $\frac{1}{2}'' = 1''$

- A. HANDLE PATTERN FOR N^o 1
- B. BODY " " "
- C. HANDLE " " N^o 2
- D. BODY " " "

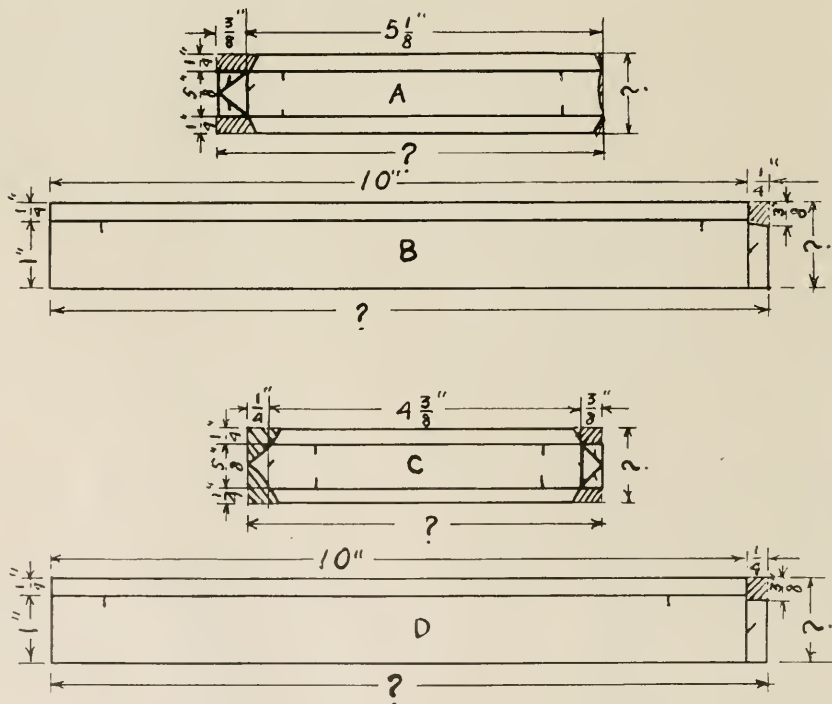

this case, meant that all products should be things which could be used in the schools. The boys could make nothing

right when he said, "Schools used to let children do things they could not do well; that, fellow teachers, is the un-



DEMONSTRATION BOARD, No. 1.

for their homes. The articles we could make for the schools were limited in number, and not of sufficient variety to build up a progressive course, and often of a construction much too difficult for a junior high-school boy. Dr. Elliot was

pardonable sin in an educational administration." In organizing an industrial course, I do not think that the "productive shop" idea before mentioned should be the dominating one, but it should not be neglected or ignored, for,



BOX (WITH DOUBLE-SEAM END) N: ■

SCALE $\frac{1}{2}'' = 1''$

A. BODY PATTERN

B. END

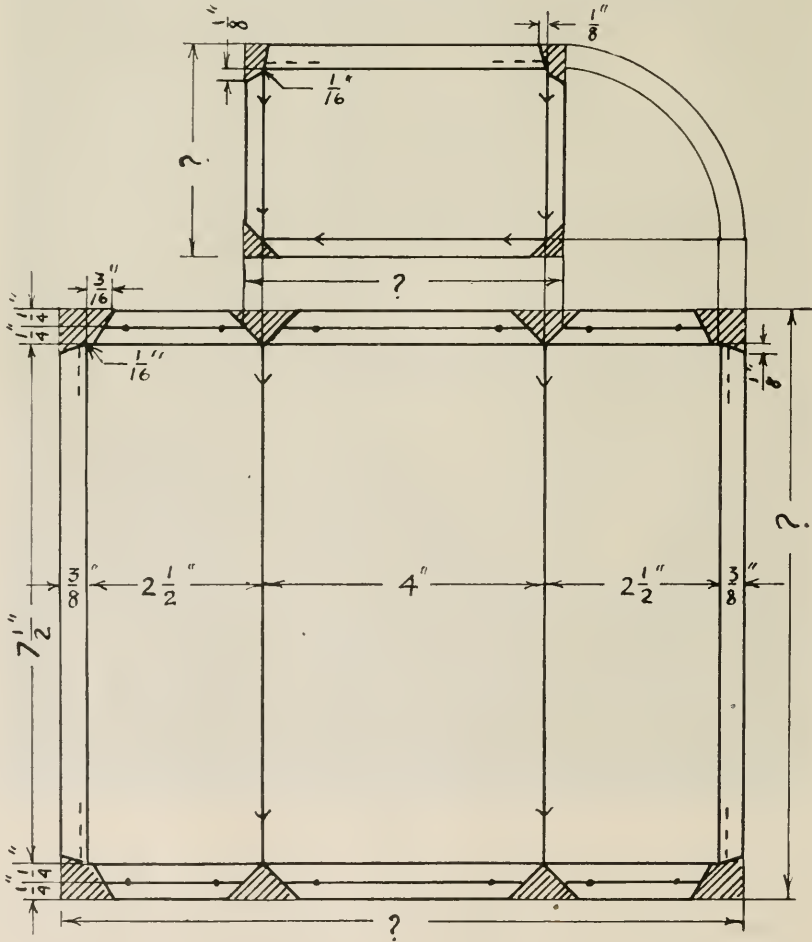

AF

if it is worked out in the proper place in the course, it has many practical as well as educational values.

much needed home interest. In sheet-metal work we have a rare opportunity to do this. How to repair cooking uten-

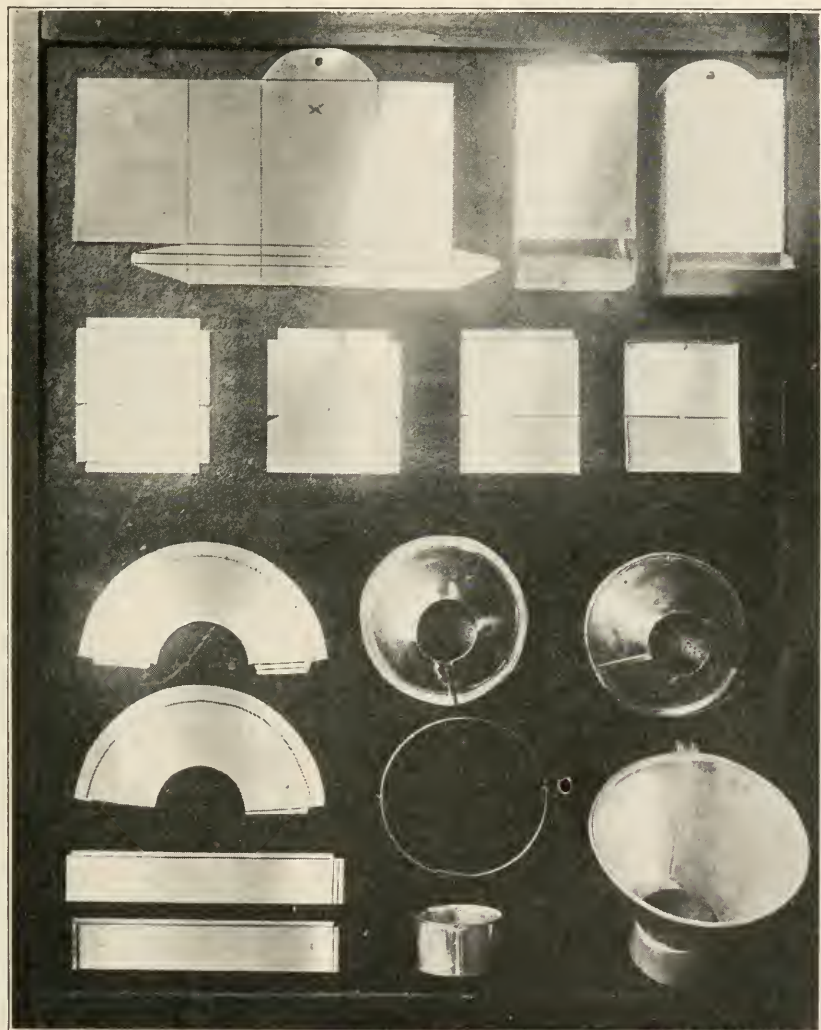

DEMONSTRATION BOARD No. 2.

Any industrial work in the junior high school should be try-out work and, taking into consideration the age of the pupil, the subject-matter taught should be made as interesting as possible. As many articles as possible should be useful things for the homes, thus creating a

silis is important sheet-metal shop knowledge and should be provided for in the course.

There is a great opportunity for correlation between sheet-metal work and other subjects, and such correlation has been successfully carried out in our school.

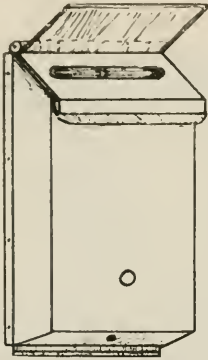

MAIL BOX No. 1

SCALE $\frac{3}{8} = 1"$

A. BODY PATTERN

B. BACK "

C. OUTSIDE TOP "

D. INSIDE "

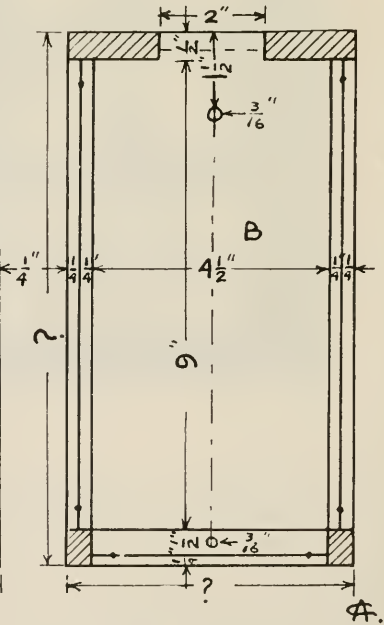
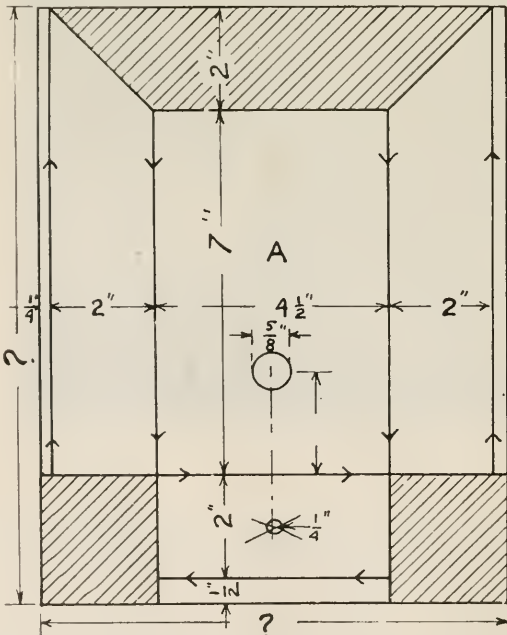
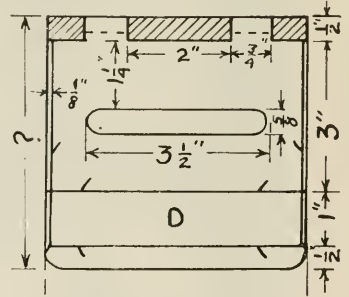
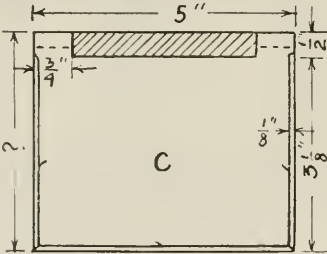

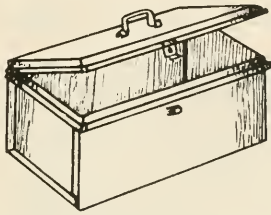

LUNCH BOX NO. 1

SCALE $\frac{3}{8} = 1$ "

- A. BODY PATTERN
- B. END
- C. COVER
- D. HASP
- E. HINGE
- F. CATCHER
- G. HAND

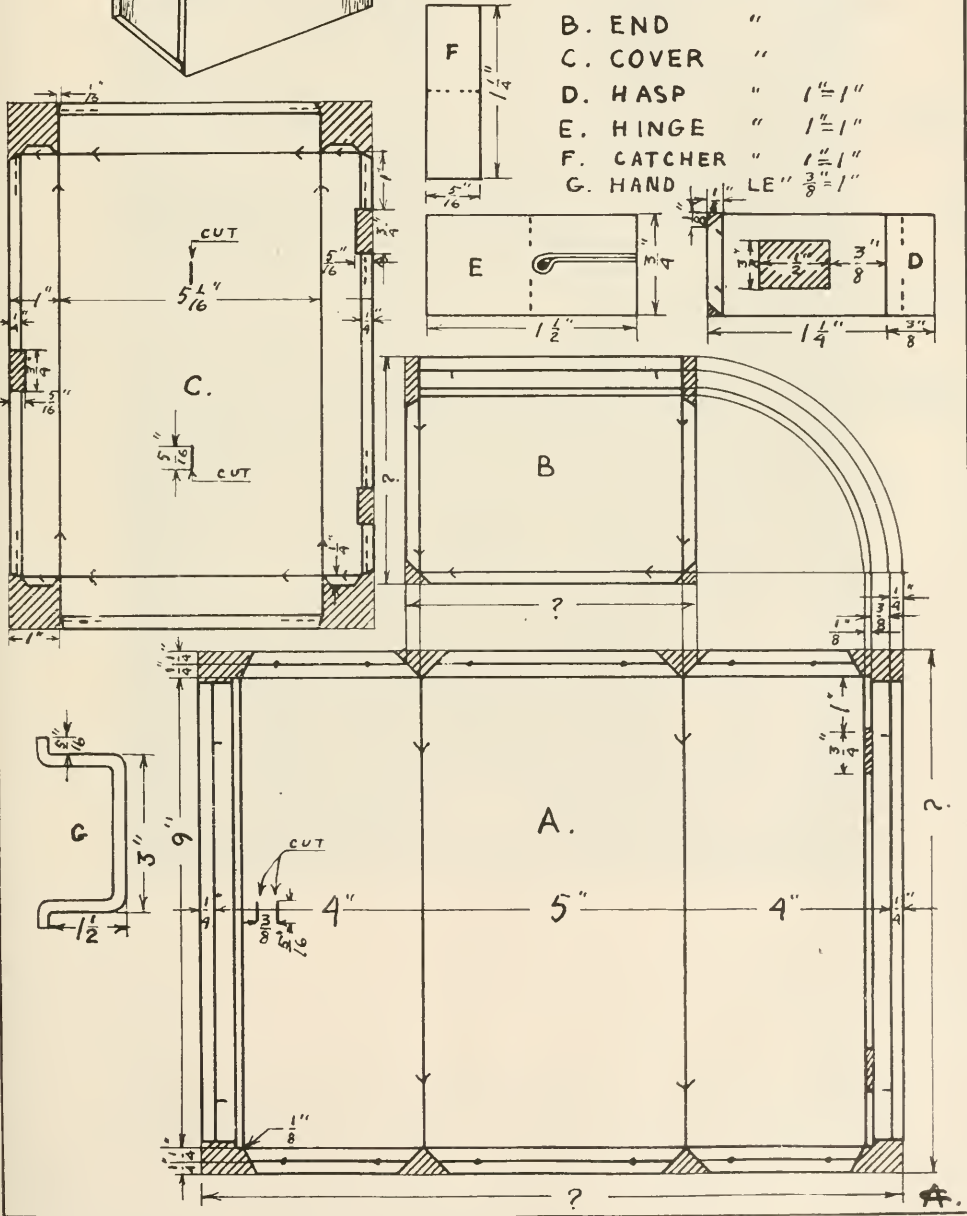

DUST PAN No. 1

SCALE $\frac{3}{8}'' = 1''$

A. PAN PATTERN

B. HANDLE "

C. STAND "

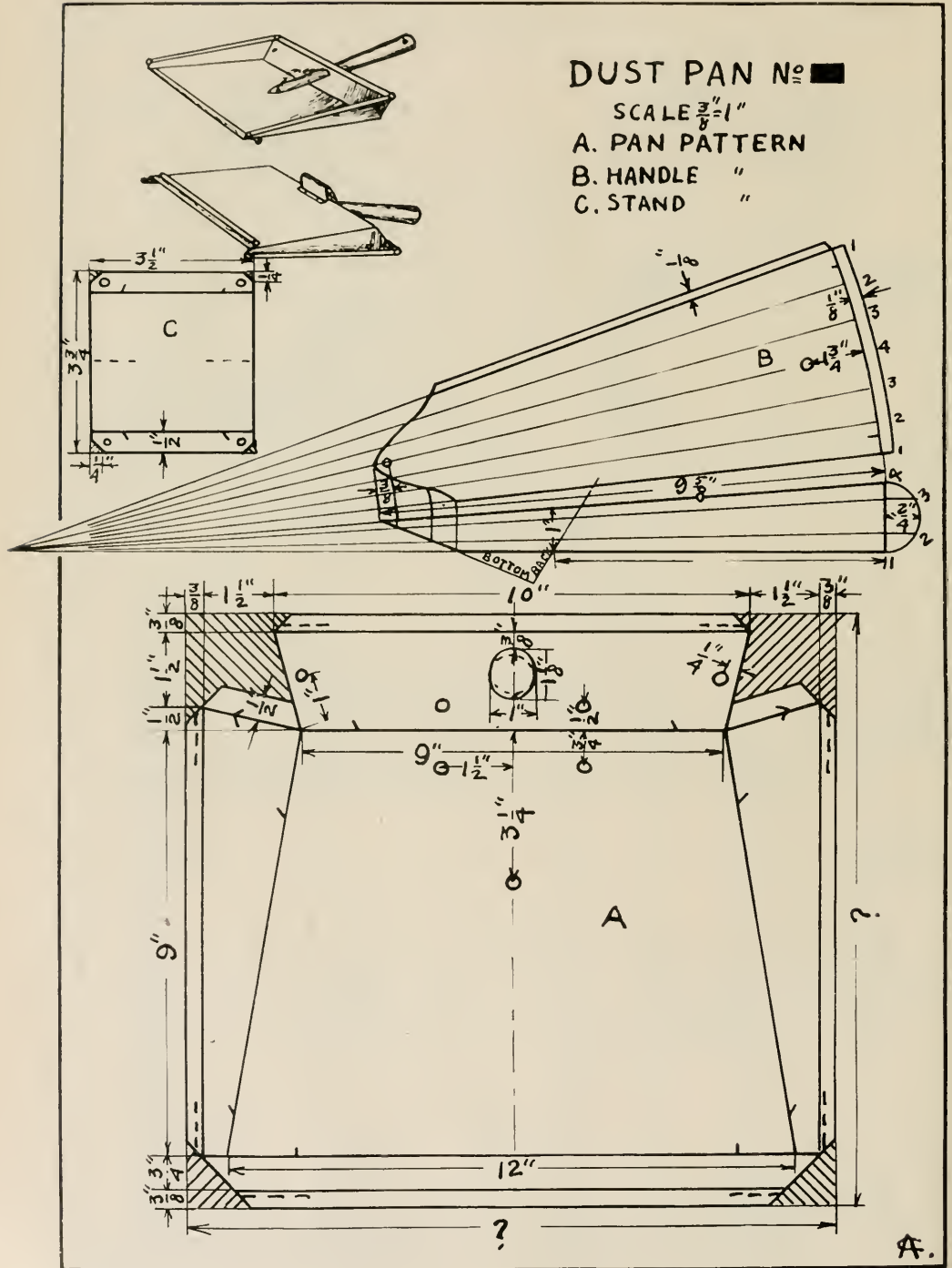

The accompanying outline shows a progressive course in sheet-metal. The crosses indicate new processes. In Pro-

panel and procedure sheet supplement the teacher's demonstration, and make it easier to handle a large class.

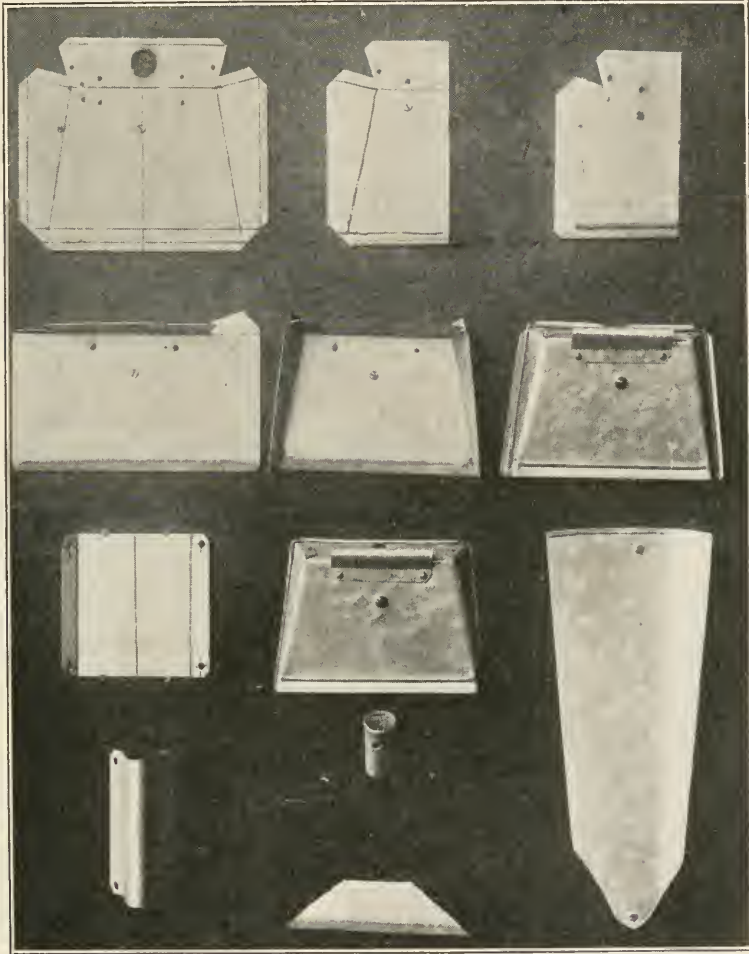

DEMONSTRATION BOARD NO. 4.

duct A processes 1, 2, 3, 4 and 5 are learned. In Product C processes 8, 9 and 10 are learned, and processes 2, 3, 4 and 5 are repeated. A short lesson sheet or procedure, Fig. 2, accompanies each drawing. The different steps in the development of the various objects are worked out in tin, in either full or reduced scale, and mounted on panels, Figs. 3, 4 and 5. The development

DUSTPAN

Material: Galvanized iron No. 28 gage or lighter.
Wire No. 10.
Rivets, $\frac{3}{8}$ " \times $\frac{1}{4}$ ".

Procedure:

1. Lay out and cut the pattern for body. (See blueprint No. —).
2. Punch holes in the back for the corner rivets and for the stand; also on the bottom; stamp the hole for the handle, (should be stamped from the outside).

COAL SHOVEL N^o 1

SCALE $\frac{3}{4} = 1"$

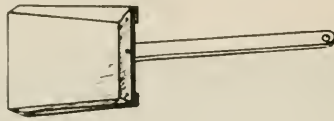

- A. BODY PATTERN
- B. HANDLE "
- C. " WHEN FORMED

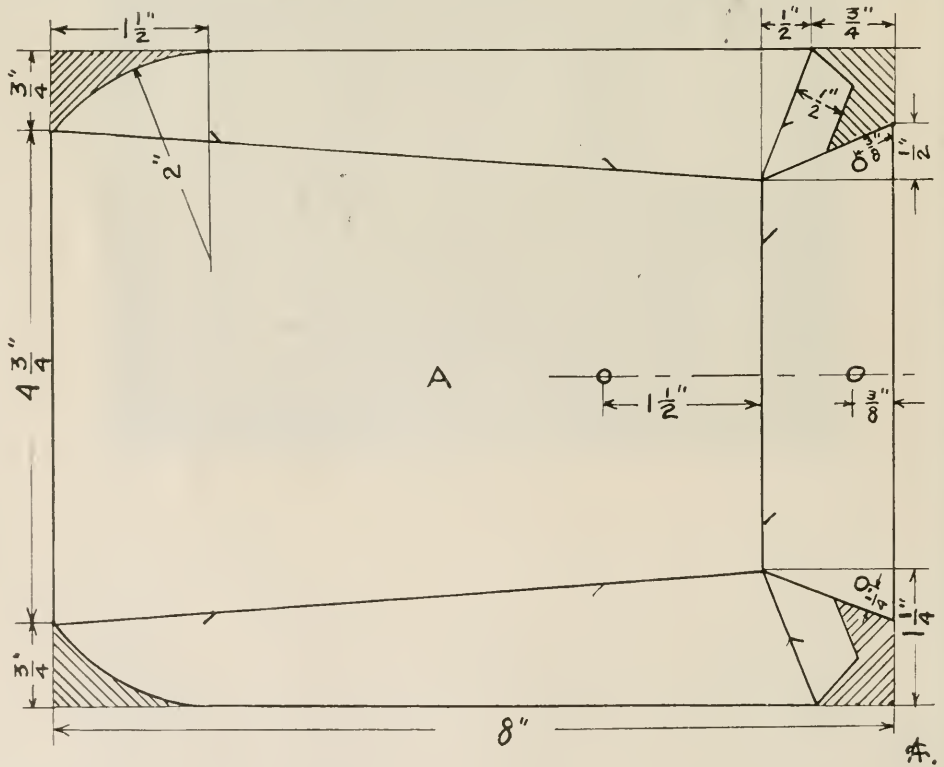
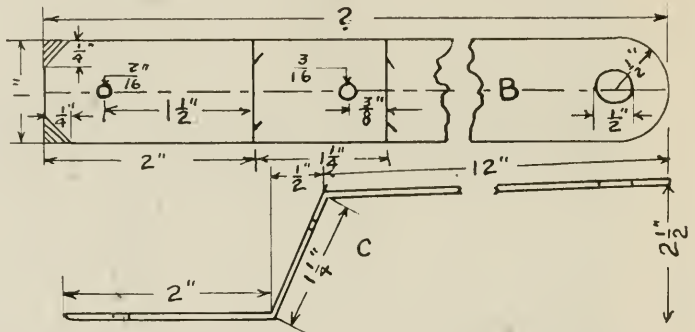

3. Wire the front edge and break the same on the proper place.

4. Break the back and sides.

5. Break the flaps, and rivet.

6. Wire the back and sides.

7. Lay out, cut and form the stand.

8. Punch holes, and rivet in place.

9. Lay out and cut the patterns for the handle.

(See lesson No. —).

10. Punch the holes, and fold the edge.

11. Form and solder the handle.

12. Rivet and solder the handle to the bottom of the pan; also solder the handle to the back on the outside.

13. Paint. Frost's Kopak Paint.

COAL SHOVEL

Material: Sheet iron No. 20.

Scrap iron $\frac{1}{8}$ " x 1".

Rivets $\frac{1}{8}$ " x $\frac{1}{4}$ ".

Procedure:

1. Lay out and cut the pattern for the body.
(See drawing No. —).

2. Punch holes in the back for the corner rivets, also on the bottom.

3. Break the back and sides.

4. Break the flaps, and rivet.

5. Lay out and form the handle.

6. Layout the rivetholes, and punch them.

7. Drill the large holes.

8. Rivet the handle in place.

9. Paint with Frost's Kopak Paint.



MODELS FINISHED WITH ENAMEL PAINT.

EDITORIAL REVIEW FOR THE MONTH

THE MANUAL ARTS CONFERENCE

WHAT a wonderful building! This expression was heard on every side by the members of the Manual Arts Teacher-Training Conference at Ann Arbor, Dec. 8, 9 and 10, conducted by the U. S. Bureau of Education. The building referred to was the new home of the Michigan Union, the community center for Michigan University men, both students and alumni. With excellent hotel accommodations on the top floor, conference room on the third, and the use of lounge, dining rooms, billiard room, library and all the rest, the conference could not have been housed better in any city in the country.

A fine meeting! This was the parting word, as the men left on Saturday noon. The traditions of the Conference had been fully maintained. Twenty-six members were present; only one subject was scheduled for discussion at each session, and there were eight sessions. Dr. George E. Myers was host, and Dr. William T. Bawden presided at all the sessions. Dean Allen S. Whitney of the College of Education welcomed the members at the luncheon on Thursday, speaking both for himself and for President Burton, who was unable to be present.

VOCATIONAL MOTIVE AMONG HIGH SCHOOL STUDENTS

AT THE first session, State Supervisor H. W. Schmidt of Wisconsin in discussing the influence of the vocational motive in the choice of curricula by high school students, presented a summary of an investigation covering over 15,000 students in fifty-four schools. Among the facts brought out were these: Only 6.3 per cent of the pupils in these schools prefer agriculture as an occupation while 30.9 per cent of the people in the state,

according to the 1920 census, are engaged in agriculture. On the contrary, 35.9 per cent of the students prefer the professions, whereas, only 5.2 per cent of



MICHIGAN UNION

the people of the state are in professions. The contrast between the interest in mechanical trades and industry as compared with business and clerical work is similar, but not quite so striking. Only 4.3 per cent want to go into mechanical trades, while the state uses 34.1 per cent of its people in this way. Counting both boys and girls, 22.4 per cent prefer business and clerical occupations, while the state needs only 15.2 per cent of its population in these occupations. Other figures were given, but these two groups became the center of discussion. It was pointed out (a) that the agricultural and industrial occupations are still recruited very largely from young people who have

never reached the high school; (b) that the special courses offered in the high schools do not seem to influence students of these schools to any material extent in the choice of occupation; and (c) that definite courses in occupational study are needed in high school, but these should begin below the regular four-year high school. The speaker said that some of us are under a misapprehension of the function of special courses in the high school and then asked, "Is it vocational?"

Professor Emery T. Filbey, in discussing this subject, said that he was not interested in occupational study classes as such, but that occupational information should be included in courses in social science, history, printing, etc. He regarded the occupational study class as merely a transition scheme for meeting present conditions which should be temporary. He especially emphasized the need of some way of measuring how well a person is qualified to do certain jobs which are essential to the various possible occupations.

NEED FOR MORE ELEMENTARY INDUSTRIAL SCHOOLS

AT THE third session C. F. Kleinfelter, of the Federal Board for Vocational Education, discussed teacher-training problems of the general industrial school provided for in the Smith-Hughes Act. He pointed out that the purpose of this school was to allow small cities and towns to benefit by trade preparatory work, but he said that only a few such schools had been established and, when established, they had shown a tendency to become unit trade schools. Moreover, as comparatively less attention has been paid to all-day trade schools because of the greater popularity of part-time instruction, which helps the people already in industrial occupations, the elementary industrial school was receiving very little attention.

In the course of the discussion following Mr. Kleinfelter's presentation these ideas came forward: (a) That more elementary industrial schools are needed so that the Smith-Hughes Act may become more popular by meeting the needs of a larger number of people in the industrial field; (b) That a trade in a small community is not the same as in a large industrial city—it is not so highly specialized. The small community needs general woodworkers and general metalworkers more than highly specialized tradesmen; (c) And that the greatest difficulty in the progress of this type of school is in the fact that students in such a school are not allowed at the same time to take any of the regularly organized courses in the high school.

Mr. Kleinfelter referred to a school in North Dakota that had overcome this difficulty by allowing the students to enter the regular high school classes for two subjects. One hour only was given to "related subjects" and the other three to the trade work. This arrangement seemed to meet with the approval of many of the members of the Conference.

In outlining the requirements for a teacher of shopwork in such a school there was a very general feeling that the evening normal courses for tradesmen do not yield the desired results. More time in school is needed. Better teachers would come from the manual arts courses for teachers in the teacher-training colleges provided such courses were strengthened by (a) summer work in the trade or (b) co-operative courses or (c) by enrolling men who have had actual trade experience. The latter was regarded as the most desirable. It was stated that this kind of student given a two-year course will make the best teacher, but it was recognized that tradesmen with the high school preparation necessary to enter such college courses are not usually

attracted by the salary schedule of the teachers of industrial work. Professor A. F. Siepert doubted whether a two-year course is sufficient in length for training the ordinary high school graduate for this special teaching work.

On motion of State Supervisor K. G. Smith, a committee was appointed to draft resolutions with reference to the elementary industrial school. This committee's report at the last session of the Conference was as follows:

Whereas:

It was the original intent of the Smith-Hughes Law to promote Industrial Education in cities of less than 25,000 as well as in larger cities, and

Whereas:

The type of all-day industrial school described as a general industrial school in Bulletin 17 of the Federal Board for Vocational Education has developed into nothing more than a unit trade school with a slight decrease in the required hours of instruction, and

Whereas:

Such a school is not, in our opinion, the type of school best suited to promote industrial education in cities of less than 25,000 and is in most cases impossible of establishment in such cities, and

Whereas:

The support of all communities, both large and small, is necessary for the proper expansion and support of an industrial education program, therefore

Be it resolved:

That in order to develop a type of industrial education in these smaller cities suited to their needs, a different interpretation of the term "general industrial school" is needed, and more latitude in its organization, and

Be it further resolved:

That in our opinion the term, general industrial school, as provided for in cities of less than 25,000, should mean a school whose purpose is to fit persons for useful employment in the field of wood and metal working, in printing, in the building trades, or in such other vocational activities as local conditions warrant, and

Be it further resolved:

That in our opinion such a course should include as a minimum $2\frac{1}{2}$ hours per day or $12\frac{1}{2}$ hours per week of shop or trade work, together with at least a 1-hour period devoted to definitely related subjects in a segregated class, and

Be it further resolved:

That in our opinion the teacher needed for a school of this type is such an one as is now required for high grade junior high school or part-time school industrial work, and

Be it further resolved:

That in view of the importance of this field a careful study of the experience and training needed by such teachers should be made.

Submitted by the committee:

K. G. SMITH
T. T. LINDSEY
ARTHUR B. MAYS
ELDON L. USRY
G. E. McLAUGHLIN.

THE CREATIVE IMPULSE IN
INDUSTRIAL WORK

ON FRIDAY morning Professor Fred C. Whitcomb, of Miami University, presented the topic, "The Manual Training Teacher's Part in Stimulating the Creative Impulse." He said that modern industry as at present organized affords little opportunity for the average worker to develop initiative and resourcefulness; it is concerned chiefly with production. In the earlier or craftsmanship stage of industry there were many more opportunities for the worker to express his personality in his product. Modern industry, however, is organized in harmony with the requirements of modern society and is, therefore, organized on a permanent basis. The speaker contended that the factory plan of modern industry may be reorganized to provide for the social creative impulse, but it will need the assistance of the school in doing so. He believes that the junior high school period, which is fraught with the spirit of amateur production and the desire for social adventure, is the time to foster this creative impulse; habits formed then may be turned to good account later. He would, therefore, recommend the individual project in industrial arts instruction.

In the discussion that followed, James McKinney contended that the automatic

machine is not deadening to the man with brains. Joy in life comes from consciousness of rendering social service as well as from craftsmanship. E. Lewis Hayes, supervisor of industrial education in Detroit, said that there are people who are happy in a monotonous job, and added, "I know of no one doing a more monotonous job than teaching 'Algebra I' five hours a day. A man working on an automatic machine may be miserable, especially if anyone tells him he is, but otherwise, he is likely to be contented. There is a large group of workers who want to do a repetitional job. The complaint in the factory is that the boys from the school will not stick to their jobs. They get started, and their creative impulses come up and interfere." Other speakers contended that running an automatic machine requires foresight, that modern industry does provide an opportunity to exercise creative effort and adventure.

The discussion turned on the suggestion of Miss Cleo Murtland who called attention to Dr. Richard Cabot's book, "What Men Live By." This book points out that men need monotony as well as variety, and that it is in the proper balance of these that greatest satisfaction is found. Moreover, it was pointed out that such a proper balance results in a different proportion in each individual. Then followed the suggestion that we all need education "on the work level and also on the play level," and that, if the creative impulse cannot be satisfied in the work hours, it should be in the play hours, and by stimulating this impulse in the junior high school period, the school is serving either the work or the play of the later period, or both of them.

PRODUCTIVE INDUSTRY METHODS
IN THE JUNIOR HIGH SCHOOL

WILLIAM E. Roberts led the discussion of the topic "Demands on the Teacher of Manual Arts in the Intermediate School." He spoke especially of the value of productive work in such a school as a means of giving industrial information. He pointed out, however, that the purpose of the junior high school is not vocational. It may be, perhaps, prevocational, but it is surely educational in the broad use of the term. He pointed out, also, that productive work is only one factor of enrichment in the manual arts instruction and must not take the place of the project work that has proven effective in the past. The project or problem idea is just as valuable now as it has ever been. Productive work should not occupy more than half of the time of the course and it should be carefully organized.

Speaking from the experiences of teachers in the more than twenty junior high schools of Cleveland, Mr. Roberts spoke of three methods of procedure in productive work. They were

1. Quantity production under the conditions of the ordinary manual training workshop without machinery.
2. Quantity production with all the machinery required in a factory. In this case nearly all work up to the time of assembling would be done by machinery.
3. Quantity production thru hand-work and the use of jigs which simulate the use of machinery.

The speaker then spoke in some detail of the plan of organization that had proven most satisfactory for productive work. In this connection he described the "control chart" which had proven to be the key to success in carrying on such work in large classes.

When questioned concerning metal

work in the junior high school Mr. Roberts seemed to favor having one room devoted to metalworking, and in that room he would do a great variety of problems taken from several trades; as faucet repairing, electric repair work, sheet-metal work, vice work, and such automobile work as fixing spark plugs, hose connections, repairing tubes, valves, etc; but he said that the school automobile shop in general was "a mighty good place to scrap machines." The general metalworking shop, he thought, should contain, at least, one forge.

He ended by pointing out the difficulties in securing properly qualified teachers for junior high school classes, and expressed a decided preference for men from the trades who are adaptable.

The discussion brought out the fact that there is a difference between the preparation of teachers needed for the small city or community high school and that for the teacher in a large city. Probably the best type of teacher for the smaller places will come from the teacher-training colleges.

While several other topics of interest were presented, these were the ones that brought out the most pointed discussion. At the last session the entire proceedings were summarized as follows:—

PRESENT PROBLEMS

There have been two major centers of thought in the Conference: A. The disappointments, dangers, aims and hopes for vocational education and guidance. B. The function and character of the manual arts work in junior high schools, and the preparation of teachers for such schools.

Under A, disappointments and dangers, attention has been called to the following:

(a) All-day trade courses are not increasing.

(b) Elementary industrial schools have

hardly started to demonstrate their possibilities.

(c) Eighty per cent of industrial workers do not go far enough in school to enter all-day trade courses.

(d) Many students who take all-day trade courses do not remain in the trades for which they have been trained.

(e) Vocational guidance has not yet become effective in the way intended; there is no satisfactory way of measuring ability.

(f) There is very little difference in content between courses given under Federal subsidy and those not under it. (One speaker said that the only difference in agricultural courses was in the salary of the teacher.)

(g) Lack of perfect articulation between aided and non-aided courses and schools is a handicap to the educational program in many places.

The following encouragements and hopes have been mentioned to offset the above:—

(a) Real, substantial progress has been made in the education of the worker who is already in industry.

(b) There is a desire for a more liberal interpretation of the Smith-Hughes Law, especially in the cities under 25,000 inhabitants, so that the elementary industrial school can become effective in connection with the high school scheme of education.

(c) Further experiments should develop a more practical and acceptable kind of work in vocational guidance. (Doubt should surround any plan for vocational guidance that assumes to decide for the child what he should decide for himself, or confines information given to the child to industrial occupations, or fails to make opportunities for the child to get insight into the occupations of his own selection thru some real experience. Information alone, given in

occupational classes is an emergency measure, and, alone, will not do the work of guidance adequately.)

Under B, the manual arts work in the junior high school, the following propositions were brought forward:—

(a) Enriched courses for pupils of this period are now possible because more time and better equipments are becoming available.

(b) The prevocational motive should not be the only one; courses should not aim wholly, or even chiefly at teaching the methods of large-factory production. Individual-craftsman methods are still as important as ever. Both should be employed.

(c) More kinds of industrial work should be given—metalwork as well as woodwork—and a larger variety of industrial processes and materials should be included, but without sacrifice of thoroughness and high ideals of workmanship.

(d) The methods of instruction must be such as to keep alive the creative impulse in handwork. There must be emotional satisfaction in the work as well as intellectual. The element of design and beauty must be present, and this is not inconsistent with teaching the methods used in productive work.

(e) More broadly trained teachers must be secured for this instruction. The training colleges must produce the results from such material as they can get, but make an effort to get the best.

(f) The smaller cities and towns need the most help from the training colleges. The large cities are in a better position to take care of themselves.

(g) Teachers of manual arts in junior high schools must know productive processes.

Finally, as recommended by Dean Whitney, (a) manual arts and vocational educators should not expect to accomplish

their purpose immediately. They should be content to go slowly. (b) And they should not isolate themselves; they should mix more with the so-called academic teachers, for after all, education is and must continue to be a unit.



ALVIN E. DODD.

FROM Washington comes the news that December 10, Miss Catherine Filene, daughter of Mr. and Mrs. A. Lincoln Filene of Boston, became the bride of Alvin E. Dodd. The marriage took place at the Filene summer home in Weston, Mass.

This is an event of special interest to the readers of this Magazine because of the prominence of both Mr. Dodd and Mr. Filene in promoting industrial education. Altho Mr. Dodd is no longer in educational work, he seems to belong to the profession because of his efficient work in building up the North Bennett St. Industrial School of Boston and as Secretary of the National Society for Vocational Education during the period when the Smith-Hughes Law was fighting its way thru Congress. His efforts in behalf of this piece of legislation will not soon be forgotten by those who know what he did. Miss Filene has been a graduate student at Harvard University during the past year.

A POINT OF VIEW

"DEAD men tell no tales," is the familiar quotation. If such men could speak again they might confess to more sins than those for which they were convicted. They might, on the other hand, protest against the wrong done to them.

Dead philanthropists have never returned to earth to see the results of their handiwork as expressed by their wills or deeds of trust. If they could there would be scampering on the part of many boards of control of institutions, who have deliberately or ignorantly twisted the terms of the will to suit themselves.

I have often wanted to walk with the departed spirits of those who made possible philanthropic educational enterprises and hear them talk as we paced the corridors of the institutions built with their money and perhaps bearing their name.

What a pleasure it is to walk tonight with the spirit of Benjamin Franklin as he looks with bifocal glasses upon the Boston, Mass., Franklin Union. How pleased he is with the results of that very small sum of money which was left for establishing educational aid to mechanics. Thrifty and hardheaded himself, he sees how wisely this sum is invested and reinvested until the board of control has enough to carry on a splendid Union. How his heart glows with satisfaction as he notes that the class of men and the type of instruction fit in precisely with the needs of just such young men as he intended to have served.

And then a walk in the same city with Wentworth over his Institute. The efficiency in the headship and carefully worked out courses of instruction give him joy. No grand architectural monument greets his eye. No sign over the

office door of "President." No attempt to imitate Boston Tech. No elaboration of cultural studies at the expense of technical instruction.

But best of all, my walk with old Stephen Girard. He meets Cheesman Herrick and Jameson. His face glows as he walks into the dental clinic and sees the way the orphan boys have dental treatment, and into the hospital where anemic and sickly boys smile upon him as they do upon President Herrick. Here is a philanthropist who, above any other generous-hearted American, got exactly what he wanted and in the way he wanted it. He sees tonight the perfectly appointed high school building, the productive shops, the gymnasium and the playground. I wish he might be present when Herrick gives one of his Sunday afternoon talks, or that he might be behind a screen when this Lincoln-spirited man gives one of his heart-speak-out talks to one of Girard's boys in the twilight hours of a Sunday evening.

But most of all I wish Girard could stop over and attend a trustees' meeting when the discussion is around some points of expansion, to see how carefully the President and the Board weigh each proposal in terms of the desire of the founder and how carefully the fund is administered.

What professional satisfaction it is to walk thru Cooper Square and enter the Institute with Peter Cooper and pause for a moment as he sits once again in the old carriage body, now in the main corridor, before he climbs the stairs to the classrooms. If only there was time for him to hear the roll call of thousands upon thousands of young men and old who have attended the school for the very types of instruction which he laid out so long ago. Now we stand outside

before the original building. Once grand in its dignity; now grand in its accomplishments. It has seen New York move uptown and Russia, Italy, Greece, and Poland move to America. It has seen students from every nationality come miles for its evening instruction. I tell Peter Cooper that it is a Broadway of Educational Lights which lure men from hall bedrooms and rafted garrets. He knows better than I, while the Columbus Circle of pleasure seekers wanderlust the streets, that his Cooper Institute turns away hundreds of earnest fellows who would make themselves into the men of tomorrow. With dignity of building, dignity in educational aims, and dignity in administration behind him, Peter Cooper takes on before me again the form of a copper figure bearing his name which stands in the Square. I salute him as I enter the subway at his feet.

And then there is David Rankin once living a life of trade-school dreams as he sat in his small living quarters in St. Louis. What a wonderful thing it was that Gustaffson happened to be in Lewis Institute when the call came for a man to head this old man's trade school. How easy it would have been to have called it a Technical High School or a St. Louis Institute of Arts and Sciences, or a Rankin Institute of Technology. How simple a proposition it would have been to have proved that "trades cannot be taught in school" or that "there is no demand for trades in St. Louis" or that "what we need are captains of industry." What a glorious feeling Gustaffson could have had if he had labelled the administrative glass panels "President," "Vice-President," "Secretary," "Treasurer," "Registrar," etc.

I mentally wrote this editorial as I stood upon the platform before his students and thought of the personal honesty and mental integrity of the man behind

me who is labelled "Superintendent," and looked into the faces of boys and young men who are receiving what to my mind is almost if not the best trade instruction in America. I know the story of David Rankin, and I could feel him as I walked thru the shops. Here was a man who knew what he wanted. Here were trustees who knew what was desired. Here was a head who had never "smoke screened" the possibilities of trade instruction.

There are other men, and other schools bearing their names—Williamson, Pratt, and Armour. There is the Worcester Trade School where I heard the spirit of Milton P. Higgins tell me last June as it leaned over me, "What did I tell you, Dean? I knew that a productive shop and half-time work could succeed." Booker Washington's soul goes marching on each day in Tuskegee, and General Armstrong's pioneering efforts for black people is as strong today at Hampton as yesterday.

I am living tonight with these grand men of vision. With three exceptions, I have seen them all in body. I have read the story of each. As a schoolboy I knew Franklin as one who carried a roll under each arm. As a teacher I knew of Cooper's life and business sagacity. As a student of institutional management I have watched Girard College develop under Herrick. And I tell you that these men, plus the names of Higgins, Williamson and Rankin, make a story which young fellows now in vocational work ought to read.

I should have begun my message not with, "Dead men tell no tales," but with the words, "We tell no tales to some dead men because there are none to tell." As I have stated, I wrote this editorial when I walked with Rankin thru the school which bears his name. But on the train I began to think about the dead men to whom I could tell tales.

I am going to tell them to you, only I must not mention names. I am going to speak of the misuse of funds and the wrong interpretation of wills. I never pick up a well-known magazine without turning to the advertising pages to read over again the call for students to a well-known college preparatory school which advertises its excessive rates, its beautiful buildings, and grounds, its cultural studies and its manual training shops. I know the school has "Italian gardens" and "spacious lounging rooms." I wonder what old ——'s spirit is thinking about as it stalks thru the "gardens" built out of money which he left to found a school for orphans who might profit by instruction in the crafts and trades.

A while ago I saw the building plans of a "trade school for boys and needle and other homecraft work for girls." On these plans there was one building having the title "Refectory." I did not know what the term meant unless it was a new kind of laboratory or a special curriculum. I learned later that it was a fancy name for "Dining Hall."

The hour is late as I write this, and I have just heard the spirit of old —— who gave the money for this trade school say something most profane. I never met him in body, but from what I know about him he had beans and brown bread on Saturday nights and fishballs Sunday morning, and ate off a red tablecloth. But his money goes into a college preparatory school with a Head "Marster" at the head seat in the "Refectory."

And then there is the —— (I do not care to say whether it is a school or institute because you will identify it) which has struggled for twenty years to make itself into a Boston Tech. It is a model institution, i. e. an imitation of the real thing. It is neither flesh, fowl, nor good red herring. But it is fortunate for the head and his board of trustees

that spirits do not walk on his campus, nor dead hands retrace in blood expressions of their living educational desires.

To be sure, there are fool wills, and fools who make them. There is the man who made a will giving financial aid to "needy needle women" of his town. There are no needy needle women there now; women are needy, but they do not go out to sew. There is the will which would "teach trades to orphans between the ages of 6 and 14." And others like these.

But there are more fool trustees who think more of building monuments to themselves and glorifying in tablets their own importance than they do about vocational education for the beneficiaries. They seek administrative heads who have "magnetic qualities" and degrees rather than knowledge of youth and industries. They worry more over laboratories with expensive equipment than they do over shops.

I do not know these trustees. They should have nightmares because of their negligence. Neither do I know the trustees of those institutions where the spirit of their founders may walk with satisfaction and joy. I do know the administrators of institutions founded on an idea and which have stayed by that idea. Some of the trade and technical instruction in America is being administered by such men as Bitting, Gustaffson, Williston, Edwards, Jameson, Russell, Merrill, Rouillion, Prosser.

P. S. I wrote this for three types: the young man who reads the *Manual Training Magazine*, but who does not know the significance of the names of Runkle, Higgins, Larrison, Upton. Belfield, Hall, Perry, etc. and perhaps does not care to but should care; second, the older fellows like Richards, Bennett, Leavitt, etc., who like to read my point of view just to see how near I hew to the

line when I talk ancient history; third, the progressive chap who will profit by old names, that he may know how things

started, and by present day names, that he may know the men and the schools they represent. —ARTHUR DEAN.

WASHINGTON CORRESPONDENCE

CHANGES IN THE FEDERAL BOARD

THE appointment, on November 26th, of Mr. Franks to fill the vacancy created by the expiration of Mr. Munroe's term of office as a member of the Federal Board for Vocational Education, reminded me that I have neglected to report in these pages certain changes in the personnel of the Board which have taken place. Mr. Franks, a Kentucky banker and manufacturer, was appointed in accordance with the terms of the Smith-Hughes Law, which provides that one member shall represent commerce and manufactures. With the appointment of Mr. Franks all three of the original members of the Board, who took office in August, 1917, have now been superseded.

MR. CARRIS RESIGNS

THE announcement of the resignation of Mr. Carris will come as a distinct shock to many readers, but a considerable number of his friends have in fact been anticipating this step for some time.

Lewis H. Carris came to the Federal Board for Vocational Education in August 1917, as assistant director for industrial education, from New Jersey, where he had been Assistant Commissioner of Education. His was one of the first appointments made on Dr. Prosser's nomination, and he has therefore been with the Board from the very beginning. With his leaving goes the last of the original group of division chiefs, who, with Dr. Prosser, determined the policies and procedure under the general direction and authority of the Board.

In September, 1920, Mr. Carris was appointed assistant director for indus-

trial rehabilitation, and charged with the responsibility of organizing the work under the operation of the Smith-Sears Law. In June, 1921, anticipating the organization of the Veterans' Bureau under the Sweet Law, which was to take over certain activities of the Federal Board having to do with the vocational rehabilitation of ex-service men, Mr. Lamkin resigned as director. No successor was appointed, but Mr. Fidler became acting director. On August 10th, 1921, Mr. Carris was appointed to the duties of director, but with the title of administrative head.

During the period of his active connection with the work of industrial rehabilitation Mr. Carris became much interested in the special problems of education for the blind, and his studies in this field attracted the attention of two national organizations, the National Committee for the Prevention of Blindness, with headquarters in New York City, and the American Foundation for the Blind, with offices in Washington. He had just accepted an offer from the former when he was informed that the board of trustees of the latter organization had unanimously elected him director.

The objectives of the National Committee for the Prevention of Blindness are the promotion of the establishment of classes for the conservation of vision in public schools thruout the United States, the study of methods and procedure in the education of the blind, and especially the prevention of blindness. Mr. Carris' letter of resignation from the



LEWIS H. CARRIS, who has resigned as administrative head of the Federal Board for Vocational Education, to become field secretary and business manager of the National Committee for the Prevention of Blindness, with headquarters at 130 East 22d Street, New York City.



HARRY L. FIDLER, member of the Federal Board for Vocational Education, representing labor. Appointed March 25, 1921. Formerly chairman, Wage Board, representing the Brotherhood of Locomotive Engineers, Pennsylvania Railroad, Eastern Lines; also member of the State Board of Education, Indianapolis, Indiana.

Federal Board was dated November 30th, and asks that it take effect January 15th or February 1st, 1922.

GRADING ENLISTED MEN IN ARMY VOCATIONAL TRAINING

DR. MANN, chairman of the Civilian Advisory Board of the Army General Staff, gave me a copy the other day of Special Regulations No. 121, "Regulations governing the grading of enlisted men under instruction, and the granting of certificates of proficiency in vocational training." The simple plan here adopted for recording ratings of proficiency in vocational training should be suggestive to shop teachers in the public schools.

In the Army schools the instructor is required to give each student a rating of proficiency based on the actual shopwork completed, and a supplementary ratings upon "probable trade ability."

PROFICIENCY RATING

The proficiency rating is intended to show graphically the student's skill in, and knowledge of, the various elements of the vocation. The so-called unit operations which appear in all Army educational manuals provide the basis for rating. . . . The scale of proficiency provides for a range of ten units, running from one, the point of little-known proficiency, to ten, which represents the proficiency of the so-called "expert."

Points on the rating scale to conform to the various classifications will be as follows: 6 to 8, inclusive, "journeyman" or "skilled;" 9 to 10, inclusive, "expert." The points 3 to 5, inclusive, will warrant a rating as "apprentice," or "semi-skilled" in trades for which the term apprentice is not applicable. A person so classified is a learner with, in many cases, some earning ability.

To secure any one of the above ratings each essential operation must be completed with the required proficiency. (See accompanying diagram illustrating the use of the plan.)

The proficiency of students at the time of starting the course is presumed to be zero in all operations. As proficiency is developed in any unit operation,



EDWARD T. FRANKS, member of the Federal Board for Vocational Education, representing commerce and manufactures. Appointed November 26, 1921. Formerly banker and manufacturer, Owensboro, Kentucky.



CALVIN F. McINTOSH, member of the Federal Board for Vocational Education, representing agriculture. Appointed April 1, 1919, to fill the unexpired term caused by the resignation of Charles A. Greathouse; reappointed for three-years term, July 17, 1919. Formerly County Agent, U. S. Department of Agriculture, Indiana.

Trade elements.	Proficiency rating.									
			Apprentice or semi-skilled.			Journeyman or skilled.			Expert.	
	1	2	3	4	5	6	7	8	9	10
1. Connecting portable welding and cutting apparatus.....	1	•	•	•	•	•	•	•	•	•
2. Lighting blow-pipe or torch and adjusting gas pressures.....	2	•	•	•	•	•	•	•	•	•
3. Shutting off pressures and removing apparatus from cylinders.....	3	•	•	•	•	•	•	•	•	•

the progress will be indicated by drawing a horizontal line opposite the given operation from left to right, and reaching successively the points 1, 2, 3, etc. Additional ratings may be made at any time that the instructor deems that the student has made an appreciable advance in proficiency in a particular operation. . . . The curve will be plotted in at such times as the instructor or higher authority may desire, and in all cases upon the completion of the course by the student, upon the

suspension of instruction for any cause, or upon the transfer or discharge of the student.

With some modifications, it seems to me that this plan of proficiency rating could be easily adapted to the purposes of the manual training shop teacher, the mechanical drawing teacher, and others.

—WILLIAM T. BAWDEN.

IN FOREIGN COUNTRIES

VOCATIONAL TRAINING AND TESTS

AT THE recent meeting of the British Association held in Edinburgh, three sections, Psychology, Education and Economics, held a joint discussion of vocational education and tests which aroused a great amount of interest. Sir Henry Hadow presided, and among the speakers were several men prominent in science and education.

Dr. C. W. Kimmins spoke of the value of psychological tests as used in connection with the admission of defective children to special schools in the city of London. He approved, also, the intelligence tests as another means of determining fitness for promotion from one grade to another. According to a report in the *Times Educational Supplement*, he said that he had recently made an investigation into the after-employment of children in the London district, and he had found there a tragic state of things. In their first appointments large numbers of children were unsuitably employed, and they drifted from one position to another. Boys of promise became van-boys.

He said that an enormous amount of money is spent on education, but that insufficient attention was given to marketing the product of the schools. School authorities should see that there were fewer vocational misfits.

Dr. C. S. Myers, speaking as a psychologist, said that, with some exceptions, there was one occupation for which an individual was better fitted than for any other. A child who showed no special interests or abilities had been badly educated. Untold unhappiness, misery, and waste of time and money arose thru mistaken choice of occupation. Any choice of occupation must be made by the individual himself; there must be no compulsion against his own convictions. To effect a choice, however, an individual wanted in the last years of school life, first of all, knowledge and, secondly, advice. He thought a great deal could be done by the use of cinematograph films showing the

responsibilities, prospects, advantages, and dangers of various occupations. There might also be general education on the social and economic functions of the worker. With regard to advice, neither teachers nor parents were adequate to supply it, because they were without detailed knowledge of industrial requirements. Expert advice, therefore, was essential, but the teacher's co-operation still remained necessary.

Mr. F. Watts said that psychologists had to deal with living materials, and in these circumstances pegs and holes were not constant factors. The pegs changed and the holes changed. Educationists said they were turning out pegs by the thousands, and there were too many misfits, but the psychologist could not come along and wave a wand and create a magical result. Psychologists could only indicate what were the characteristics demanded in a particular occupation, and must not be blamed if their choice was not always successful. What was wrong to-day was that a boy who left school knew nothing about industry. Educationists must bring industry into more vital contact with the schools.

Mr. W. L. Hichers, President of the Economics Section said that there was much talk about round pegs and square holes, but the ordinary boy was neither round nor square. He was something more or less indeterminate in shape. But he was malleable, and in the end he became either round or square, according to the hole which he had to fit. Normally, there was nothing anybody could do particularly well, but everybody could do the general ruck of things equally badly. (Laughter.) There was a great deal to be done in regard to vocational training, but perhaps the most important aspect they had to consider was the education it was valuable to give.

PRINTING SCHOOL AT EDINBURGH

THE Scottish city, like Leeds, is to have a definite school for teaching the arts and crafts of printing, under combined auspices of masters and men. The allied crafts include book production, lithography, photo-process work, book-binding, stero and electro-typing, and wood engraving. Principal Laurie, of the Heriot Watt College, cautions them against using too much machinery in training students. All machine work, he says, is based on handcraft, and is merely a device for saving time, so that a thorough understanding of what a machine ought to do is only possible to those who have mastered the trade crafts.

—THE SCHOOLMASTER.

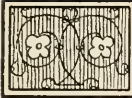

PROJECTS, PROBLEMS AND NOTES

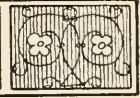

A CIRCULAR SHOP!

THE writer is not so old that he is afflicted with rheumatism. He believes that his powers of endurance are still wonderful. Only about yesterday did he cease being an officer in the armies of the United States. However, manual training should have its place in the sun, and that is the burden of this article.

The common practice of a row of windows at the right, or a row of windows at the left, or a row of windows at the rear for manual training in somebody's basement is all wrong. "Now hammer in a ladylike and soft manner boys, because someone upstairs needs a nap during geography study period."

My plan for a manual training shop, even in small towns, is not only outside, separate and away from other classrooms but I wish to suggest a circular building. Now I am not aiming entirely at a reputation for humor but am holding my face perfectly straight. See that you do the same. The building should be one story and above a high basement. The roof should be sawtooth factory construction. The sidewalls should have plenty of windows all around. Let the building be octagonal or of more sides with a tool-room, tool boards, the instructor's desk, demonstration bench and other paraphernalia parked at the center. The bench rows should radiate out, giving more elbow room for the benches toward the outer end. There should be room to make a 15-foot recitation bench just requested five minutes ago by the teacher of the third grade in the Washington School over on the East Side and reasonably to be expected ready for use by next Monday morning. This can go on while you continue supervision of the glove boxes being made on the front benches.

I believe in drawing tables or shelves around the outer walls under the windows in the wood-working room ready for access and supervision all of the time. At the end of each aisle between the rows of benches is a trap door. What for?

Why, to be lifted up at the end of each class period for the monitor of each row of benches to push the shavings down its ample throat. Yes, scrap boards and short pieces all go down there. What becomes of them?

There is a sort of circular tray running all around the building and the janitor, or somebody else that looks like a janitor, goes around and sorts out whatever can be used again. This happens once a

day when the supposed janitor is supposed to be riding with his best girl in his Cadillac on the boulevard. The remaining shavings—I mean in the trough—are pushed around by the sure-enough janitor into a wagon or box located in a pit. The box is rollable on a track to the real basement where all of the janitors now hold forth undisturbed in their ancient and newly restored domain, as is right and proper, having been relieved of invasion by all fake janitors and troublesome boys. They are now amply protected by the old "Keep Out" sign at the basement entrance.

We all know that the best factory lighting always comes from overhead. That is our deserved place in the sun and we must get it from those who need to be informed. All superintendents' magazines please copy. I want to choose my light from any and all directions.

MILES H. ROGERS,
Manual Training Instructor
Cambridge, Idaho.

FLOOR LAMP AND SHADE

THE floor lamp shown will be found interesting as a benchwork problem. Floor lamps as wood-turning problems have long been made, but pleasing designs suitable for benchwork problems are not as easily found. The one shown has been made by many of the writer's students, and has proven very popular. The base is sometimes made solid as shown and sometimes made in sections. The latter method will be profitable for more advanced students. Some variation in shape have been made but the octagonal seems to be the most pleasing.

The upper part of the drawing shows a method of making a wire shade frame suitable for floor lamps. The making of a shade or procuring a shade suitable for such lamps is always a problem for students because of the expense. A good shade usually costs about \$20.00. The shade here shown can be made for a few cents and a suitable cover for only a few dollars.

To construct the frame only a few feet of wire, some solder and a bit of tin are required. All ribs of the frame are fastened to the rim by tin sleeves as shown at F. The rim is joined by a tin sleeve as shown at D. The tin sleeve should be soldered to the rib as at E before attaching to the rim. Any heavy tin will do for the center support. The shade may be made round or octagonal as shown.

The cover for this shade is the simplest part of

FLOOR LAMP

WIRE FRAMES
FOR
LAMP SHADE

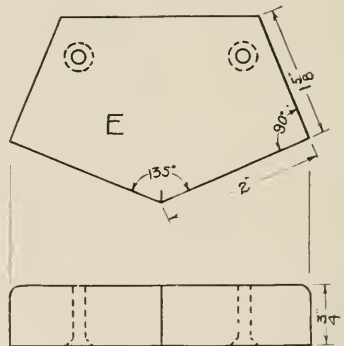
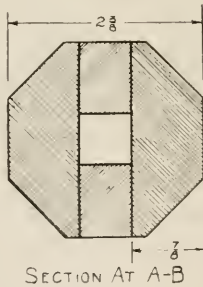
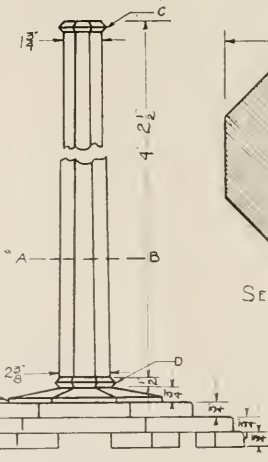
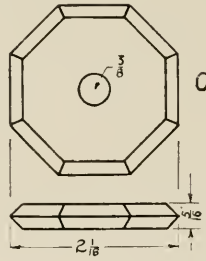
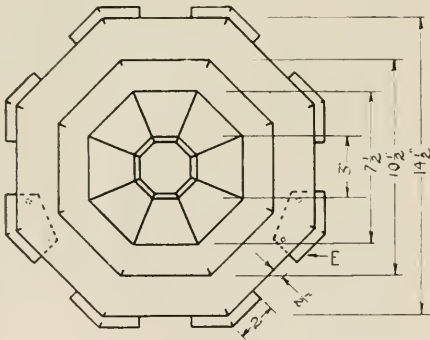
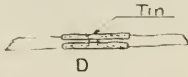
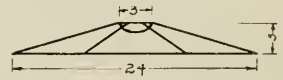
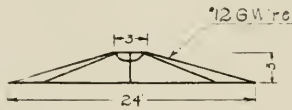
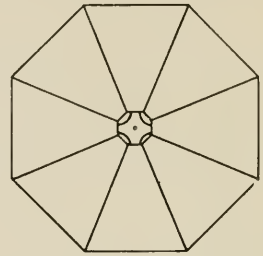
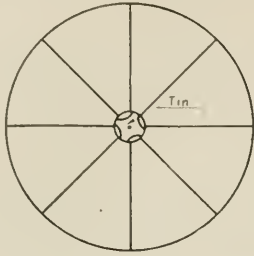

STAND FOR FLOOR LAMP



all. It is only necessary to procure a square yard of some suitable material such as silk. Bind this with braid, place a tassel at each corner, and spread over frame. This makes a very pleasing shade and as the cover may be taken off at will, dust does not collect and cause the pieces to become unsightly.

Two light chain-pull fixtures will give good results with this lamp.

A. W. DRAGOO,
Asst. in Manual Training
Ill. State Normal University.

told the boys that if all the parts were perfect the bridge would hold up a weight of nearly a half ton.

AN INDIRECT LIGHTING FIXTURE

IT BECAME necessary a short time ago to install in the stockroom of the writer's shop some form of artificial illumination.

Putting the matter before the class it was decided to construct, with the help of the sheet-metal class, some sort of a fixture. Obviously, electricity was to be used as the illuminant.

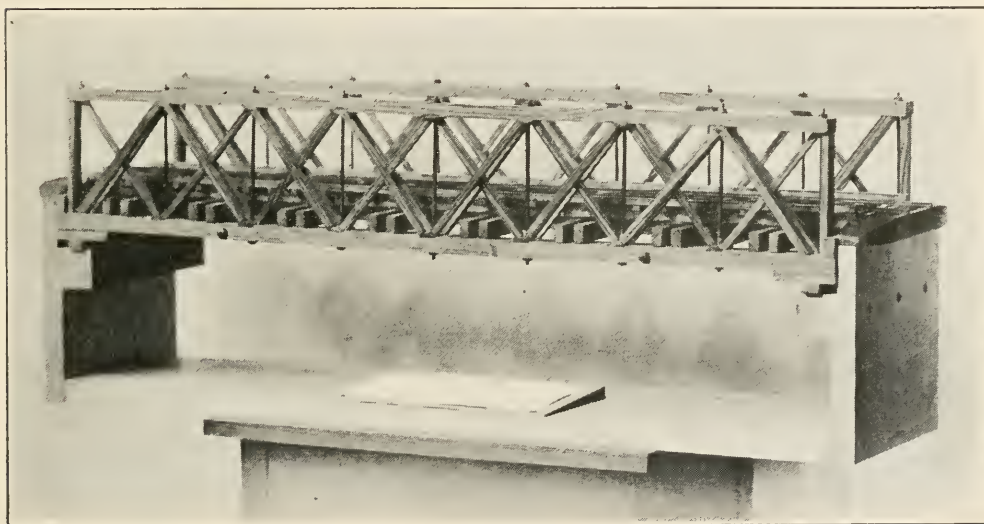

RAILWAY BRIDGE

THE accompanying photograph shows a model of a bridge that was constructed by grammar grade boys at the Walker Manual Training School, Portland, Me. It was made from the working blueprints of the Boston and Maine Railway bridge at St. Johnsbury, Vt. These were obtained thru a bridge engineer. The scale employed was $\frac{1}{2}$ " to 1 ft. The bridge was built as a class project on extra time. The class was divided into two groups, with two superintendents and a time-keeper. One group built one side of the bridge, and one the other. Every boy in the class worked on the bridge. The total time required in the construction, according to the timekeeper, was 39 hours and 32 minutes.

O. Warren Neal, the instructor in charge of the class, and the one responsible for the methods employed, says that when the bridge was completed he had the bridge engineer come to the school and give the boys his criticisms of their work. The engineer

A discussion on the various types of lighting systems, led the pupils of the class to believe that the indirect system would be the best in this particular case on account of the simple nature of the fixture. A fixture was therefore designed and the plans sent to the sheet-metal shop where the pans were made up of sheet tin. The thickness of this metal was left to the discretion of the instructor in this department. The ceiling block was cut out in the wood-shop. The only materials which it was found necessary to purchase were the suspension chains. These were cut out from dog-chains which cost ten cents each. A piece of hard rubber was used in the upper pan bottom to form a support for the drop-cord as well as to insulate it from the metal.

The inside of the lower pan was highly polished so as to form a suitable reflecting surface. The outside was given several coats of good white enamel paint which was striped with gold bronze. When

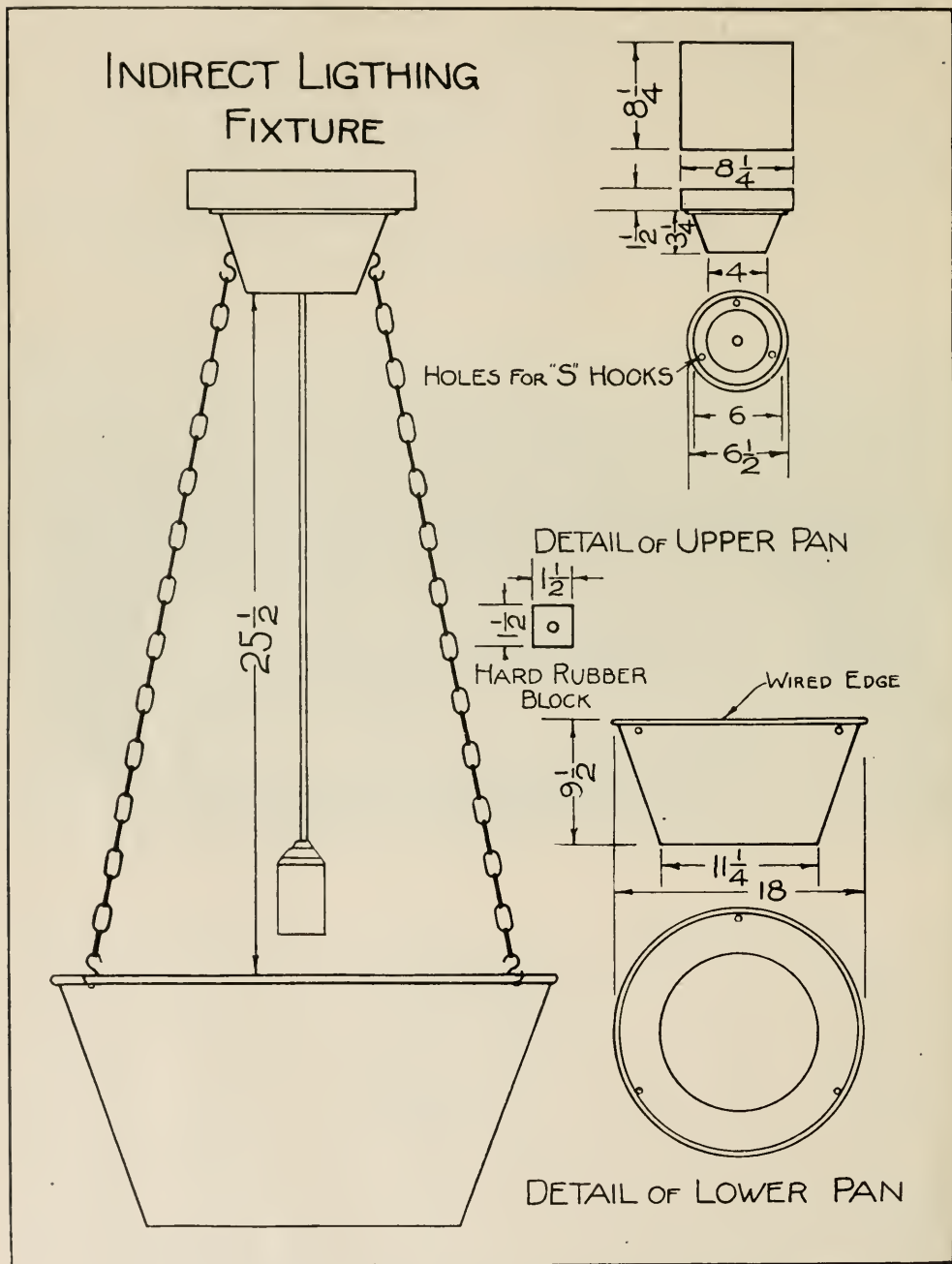

used with a 75 Watt C 2 Mazda lamp this fixture gave excellent results.

M. F. PERRY,
Lyceum Hall Electrical Shop
Boston, Mass.

ANOTHER MANUFACTURING PROBLEM
THE drawing of the magazine cabinet and display rack was sent by Joseph M. Speer of Pittsburgh, Pa. This is another problem similar to the folding chair given in the December number.

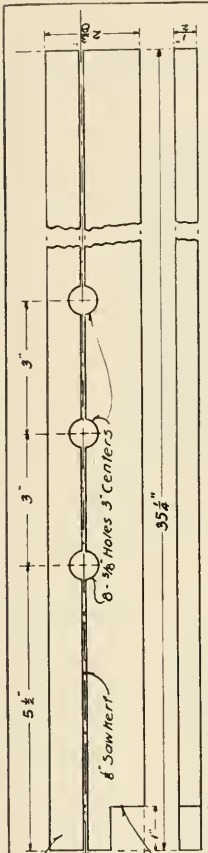

Back of Cabinet to be framed up like Side Panel of Cabinet, with two Panels, must be perfectly square, a snug fit in Rebates and fastened securely so Cabinet will stand Dumb.

APPROVED *William W. Gardner*
SUPERINTENDENT OF SCHOOLS, N. Y. C.
APPROVED *Joseph B. Brown*
SUPERINTENDENT OF BUILDINGS, N. Y. C.

ITEM	NAME	MATERIAL	SIZE	REQD
1	Top Rail	To suit finish	3/4" x 1 1/2"	2
2	Lower Rail		3/4" x 1 1/2"	2
3	STYLE		3/4" x 3 1/2"	4
4	STYLE		3/4" x 2 3/4"	4
5	Panel		1/2" x 5 1/2" x 28 1/2"	4
6	Top Rail		3/4" x 2 1/2" x 9 1/2"	2
7	Lower Rail		3/4" x 2 1/2" x 9 1/2"	2
8	STYLE		3/4" x 2 1/2" x 2 1/2"	3
9	STYLE		1/2" x 2 1/2" x 2 1/2"	1
10	Panel		3/4" x 2 1/2" x 2 1/2"	2
11	Shelf Batten Support		3/4" x 1 1/2" x 3 1/2"	2
12	Shelf Batten		1" x 1" x 16"	4
13	Front Batts		1/2" x 5 1/2" x 15 1/2"	6
14	Shelf Batts		3/4" x 1 1/2" x 23 1/2"	1
15	Top Board		3/4" x 1 1/2" x 23 1/2"	1
16	Bottom Board		3/4" x 1 1/2" x 23 1/2"	1
17	Back Bottom		3/4" x 6" x 16 1/2"	3
18	Partitions		1/2" x 1 1/2" x 21 1/2"	4
19	SHINES		1/2" x 1 1/2" x 21 1/2"	3
20	Apron		3/4" x 1 1/2" x 18"	2
21	Back Batts		3/4" x 1 1/2" x 23 1/2"	1
22	Back Front		3/4" x 7 1/2" x 23 1/2"	1
23	Hinges	BRASS	1 1/2" x 2 1/2"	4
24	FRICTIO CATCH	BRASS	1/2" diam.	2
25	FRIBS	BRASS	1" diam.	2
26	Elbow Catch	BRASS	3/4"	1

STANDARD
MAGAZINE CABINET & DISPLAY RACK.
SCALE: 1/2" = 1' & 3" = 1'

THE BOARD OF PUBLIC EDUCATION
DEPT. OF BUILDINGS PITTSBURGH
APPROVED BY *[Signature]* TRACED BY *[Signature]* SHEET NO. 5-190
DATE 1921. MONTH 10, 1921. DATE 1/4 1921.

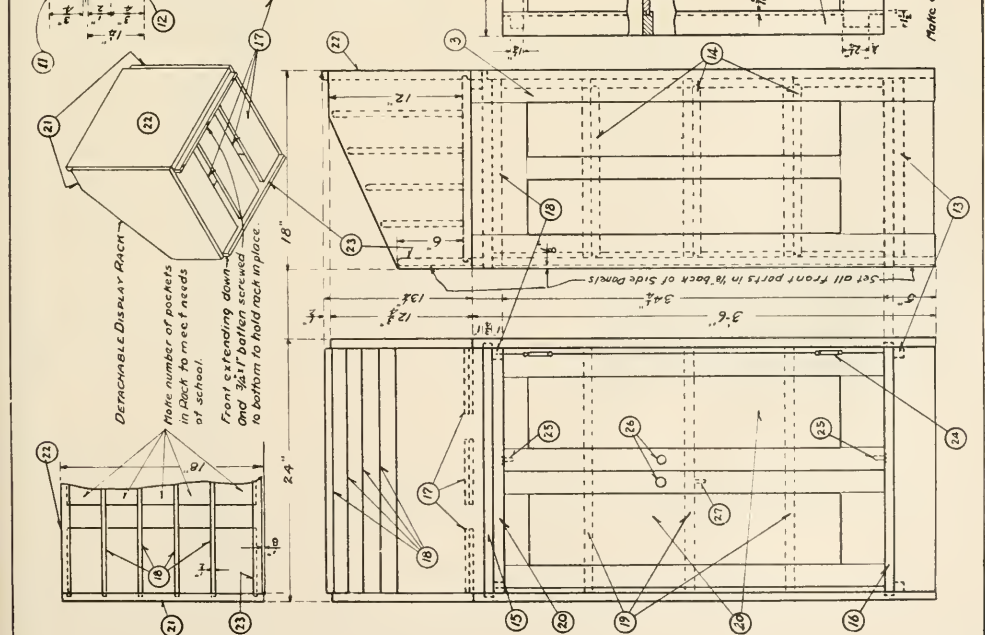

DETACHABLE DISPLAY RACK
Make number of pockets in back to meet needs of school.
Front extending downward and 3/4" batten screwed to bottom to hold rack in place.

Note all grooves for Panels 3/8" deep.

Set all front parts in 1/8" back of side panels.

CURRENT PUBLICATIONS

Modern Applied Arithmetic. By R. R. Neely, Supervisor of part-time schools, Peoria, Illinois, and James Killius, director of vocational education, Johnstown, Pennsylvania. Published by P. Blakiston's Son & Company, Philadelphia, 1921. Size 5 $\frac{1}{4}$ x 7 $\frac{1}{2}$ in.; 154 pages; illustrated; price 70 cents.

This book contains eighty unit lessons in arithmetic, all having a direct bearing on practical situations in the life of the pupils. Explanatory notes and illustrations which are used to introduce each lesson will tend to create an interest in the students toward the problem and will make them see the value of the problems and their application in every day affairs. The title of the book *Modern Applied Arithmetic* is indeed well chosen.

Lessons in Lettering. By Thomas A. French and William D. Turnbull. Book 1, Vertical Single-Stroke. McGraw-Hill Book Company, New York. Price, 35 cents.

This is one of a series of practical books with text, examples and exercises. It contains several new features in teaching lettering which will be of interest to teachers of the subject. The work is to be done in the book on guide lines printed with orange-colored ink. Thruout the book there is a discussion of each problem and in the back of the book there are several sheets devoted to dimensions and symbols.

RECEIVED

Technical and Trade Training Thru the Continuation School. By Edward A. Fitzpatrick. Wisconsin's Educational Horizon. Volume 3, No. 6. Published by the State Board of Education, Madison, Wisconsin.

Present Status of Music Instruction in Colleges and High Schools. Report of a study made under the direction of the U. S. Bureau of Education by a joint committee of the National Education Association, Music Teachers' National Association, and Music Supervisors' National Conference. Bulletin No. 9, 1921. Issued by the Bureau of Education, Washington, D. C.

Connecticut Trade and Vocational Education. Plans for the administration of the Smith-Hughes Act. Issued by the State Board of Education, Hartford, Conn.

Egg-laying Characteristics of the Hen. By James Dryden. Bulletin No. 180. Issued by the Experiment Station, Oregon Agricultural College, Corvallis, Ore.

Administration of the First Federal Child Labor Law. Bulletin No. 78. Issued by the Children's Bureau, U. S. Department of Labor, Washington, D. C.

Industrial Rehabilitation. Services of Advice and Co-operation. Bulletin No. 70. Issued by the Federal Board for Vocational Education, Washington, D. C.

Tuskegee's Mechanical Department. By R. R. Taylor, Director of Industries, Tuskegee Institute, Tuskegee, Alabama. Reprint of an article in the *Southern Workman*.

Textile Fibres and Fabrics. By Helen A. Bray. Bulletin issued by the College of Industrial Arts, Denton, Texas.

What's What in Textiles. By Julia F. Tear. Bulletin issued by the College of Industrial Arts, Denton, Texas.

The Volute in Architecture and Architectural Decoration. By Rexford Newcomb. Bulletin No. 121. Issued by the Engineering Experiment Station, University of Illinois, Urbana, Illinois. This is a valuable, illustrated monograph for students in architecture and design.

Safety Instruction Manual for the Cleveland Public Schools, Grades 1 to 6. Published by the Board of Education, Cleveland, Ohio.

The Housing and Equipment of Kindergartens. Bulletin No. 13, 1921. Issued by the Bureau of Education, Washington, D. C.

The Ethics of the Teaching Service. A paper read before the superintendent's staff of the Cleveland Public Schools. Published by the Board of Education, Cleveland, Ohio.

Bulletin of the Western Arts Association. Containing the proceedings of the meeting held in Peoria, Illinois, May 1921. L. R. Abbott, Secretary, 234 Division Avenue, North, Grand Rapids, Michigan.

Experience as Education. Reports of some activities of the training school connected with the Teachers College, Peru, Nebraska. An illustrated pamphlet of 84 pages. One of the sections is entitled "How Sixth Grade Boys Made a Bird Bath," by J. W. Paul.

The Job Instruction Sheet for Use in Part-Time Schools. Prepared by Robert H. Rogers, Specialist in Industrial Education and Teacher Training, Division of Vocational and Extension Education, Albany, New York.

Outline for a Series of Conferences for Part-Time Teachers in Service. Issued by the Division of Vocational and Extension Education, State Department of Education, Albany, New York.

Part-Time Education of Various Types. Report of the Commission of Reorganization of Secondary Education, appointed by the National Education Association. Bulletin No. 5, 1921. Issued by the Bureau of Education, Washington, D. C.

Teach Boys the Care of Tools



This book tells the story of Caring for bits. Write for as many as you need.

Let us help you teach boys the importance of properly caring for tools they use. You will find our booklet, "How to Select, Use and Care for Bits" very thorough and interesting—a book that will be of great assistance to you in your work. We offer you these free in any quantity you may desire.

Good tools lend added zest to the work in the classroom. The boys will be proud of Irwin bits. These superior wood-boring tools are the original solid center bits.

Irwin bits are packed conveniently in sets or singly. The sets range from six to thirteen in size from $\frac{1}{4}$ to 1 inch. Packed in neat canvas rolls or wooden boxes.

Prices of Sets, \$3 to \$7

In U. S. A.

East of Rocky Mountains



The IRWIN Trade Mark stamped on the shank of every bit, is your assurance of its genuineness.



The Irwin Auger Bit Co.

245 Grant Street
WILMINGTON, OHIO

STANLEY

"Hurwood"

Screw Drivers

THE demand for Stanley Tools in the educational field—as well as among skilled workers—is due to their unusual strength, durability and accuracy.

The blade, shank and head of Stanley "Hurwood" Screw Drivers are made from one piece of special steel. The shank passes through handle and ferrule is pinned. Head has two patented projecting wings, which together with pin keep shank from turning. Handles are fluted and stained black.

These Screw Drivers range in size from 2½ inches to 30 inches.

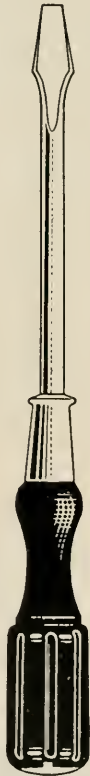

No. 20
6-inch

At good hardware stores



The Stanley Rule & Level Plant
THE STANLEY WORKS
New Britain, Conn., U.S.A.

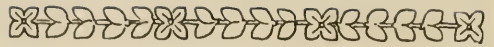

FIELD NOTES—(Continued)

"Men in this school will be taught the various trades under competent instructors, amid ideal surroundings. The dormitories have been repaired, the best of equipment procured for the convenience of the men, and everything possible done to give the men the real college spirit," said Col. Forbes recently.

"It is not the intention of the Veterans' Bureau to interfere in any way with men pursuing professional studies at any of the Universities or accredited institutions," continued Col. Forbes, "nor is it the plan to eliminate proper placement training. Men will continue in placement training with all institutions or organizations that are found suitable, and which are really helping the man, and not exploiting him."

ITEMS OF PROGRESS

DOMESTIC SCIENCE COTTAGE CONSTRUCTED

The domestic science department of the schools of Brownwood, Texas, outgrew its quarters at the beginning of this year. With the enrollment in the manual training department doubled over last year and an additional teacher employed it has been decided to make the construction of a domestic science cottage a project to be worked out by the class in carpentry. A. T. Hamilton, who is the local director of manual training, has completed the plans for this cottage and will have charge of its construction.

"WHERE THERE IS A WILL, THERE IS A WAY"

The Tamalpais Polytechnic High School, California, after purchasing nineteen machines from the government under the provisions of the Caldwell Bill, found itself in lack of the necessary \$2,300 needed for tools to be used in connection with them. W. T. Elzinga, assistant principal of the school took upon himself to raise this amount by public subscription. In the spare time and on holidays of eight weeks this money was obtained. Thru this campaign much additional good was accomplished by obtaining a greater interest in the school and a friendly attitude toward it from the people who were interviewed.

EVENING SCHOOLS WELL PATRONIZED

More than eleven hundred boys and young men have enrolled for evening school work in Worcester, Massachusetts. The school officials, who had expected a reduction in attendance on account of the present business conditions, have been obliged to divide the school into two semesters and receive one half of the applicants the first part and the other half the second part of the year. Evening classes are being taught in machine shop practice, electric-

Champion "Universal" Vise

Used Principally in Tool Rooms

WE MAKE ALSO

Full Line of Machinists Vises

Toolholders for Schools
Vises for Schools
Movable Steel and Iron
Stands
Power Hack Saws, Etc.

The
**Western Tool
& Manfg. Co.**
Springfield, Ohio

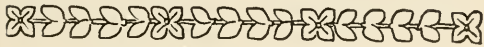
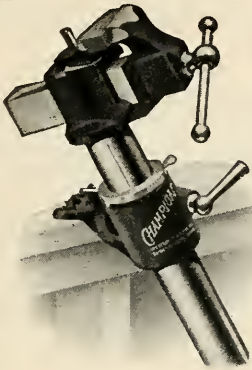

FIELD NOTES—(Continued)

ity, mechanical drawing, estimating for building trades, gas engine practice, pattern-making, printing, and shop mathematics.

HIGH SCHOOL EQUIPMENT ADDED

The high school of Tracy, Indiana, is installing an equipment of forges, lathes, drill presses, small hand tools, etc. The cost of the new equipment is approximately \$3,500. This in addition to the facilities for doing industrial work which this school already had will make this one of the best equipped high schools among those of its size in the state.

MONEY ASKED FOR LOUISIANA TRAINING INSTITUTE

The sum of \$200,000 is being asked in the state legislature of Louisiana for the purpose of equipping the state training institute for boys at Monroe. A print shop for the printing of a school newspaper, a tailor shop, a shoe repair shop, and a laundry are the proposed additions at present.

BOOST TRADE WORK AT NORFOLK, VIRGINIA

The Builders' Exchange, of Norfolk, Virginia, will join hands with the Builders' and Contractors'

SAW TABLES

For MANUAL TRAINING

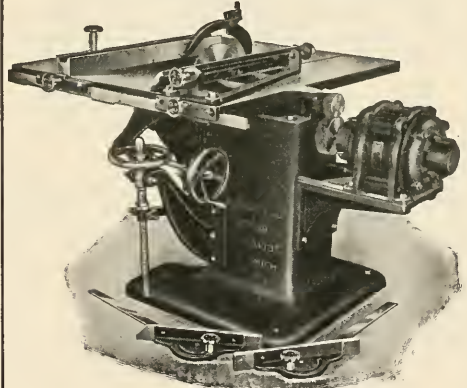

This cut shows our motor driven spiral gear saw table. No countershaft, no belts. Tilting or stationary tops. Write for circular and prices on our entire line. Address

ALEXANDER DODDS CO.

451-453 Monroe Ave., N.W.

GRAND RAPIDS, MICHIGAN, U. S. A.

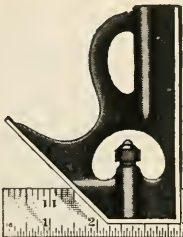

NEW
No. 65

LUFKIN

**"UNIVERSAL"
TRY AND MITRE
SQUARE
FOR WOODWORKERS**

HIGH GRADE YET POPULAR PRICED.
ACCURATE—DURABLE—WELL DESIGNED.



Distinct marking; movable yet secure head. Serves also as marking, height and depth gauge, and separate rule. *If Unobtainable at Dealers Write Us Direct.*

Made in 9-inch and
12-inch lengths

Send for Catalogue

THE LUFKIN RULE CO.

SAGINAW, MICH.
New York

Have You Seen These Four Well-known Wiley Texts?

1. Elementary Practical Mechanics.

By JOSEPH M. JAMESON

A practical text for elementary teaching and manual training schools, and an introductory text for engineering schools.

32 pages. 5 by 7¼. 212 figures. \$1.75.

2. Practical Shop Mechanics and Mathematics.

By JAMES F. JOHNSON

130 pages. 5 by 7. 81 figures. \$1.40.

3. Heat.

By J. A. RANDALL

Gives the essential principles of heat. A text-book for a very short course and a sound basis for a long course.

331 pages. 5¼ by 7½. 80 figures. \$2.00.

4. Principles of Mechanism.

By WALTER H. JAMES and
MALCOLM C. MACKENZIE.

A good text for evening technical schools, trade schools, and others. Only simple mathematics are given.

241 pages. 5¼ by 7½. 245 figures. \$2.00.

*Send for ANY Wiley book on Free Examination.
If not found satisfactory, return them, postpaid, and
the memorandum charge will be cancelled
What could be fairer than this?*

WILEY FREE EXAMINATION COUPON

John Wiley & Sons, Inc.,
432 Fourth Avenue, New York City.

You may send me the following on 10 days' approval:

I agree to pay for the books or return them within 10 days of receipt.

Name

Address

If teacher, state school.....

If not teacher, give reference.....

M. T. M. 1-22



FIELD NOTES—(Continued)

Association in seeking to have more extensive courses in manual training given in the Norfolk public schools along the lines for development of mechanics skilled in building.

It is the hope of contractors in both organizations that courses will be offered which will give the students fundamental practices in such trades as carpentry, brick-laying, plumbing and others that enable the graduates to pick up very quickly the additional experience and instruction necessary to make them skilled mechanics.

ART APPRECIATION CLUB ORGANIZED

Miss Gladys Potter Williams of the Southern Illinois State Normal University, Carbondale, Illinois, has been instrumental in the establishment of an organization known as "The Appreciation of Art Club." It started with nearly fifty members representing a number of cities and towns in the vicinity of the university. The club plans to study the architecture, sculpture and paintings of American artists, and to bring exhibitions to Carbondale. They plan to discuss appropriate dress, furnishing of the home, well-kept lawns and yards, etc. Each member of the class promises to assist in the further spread of real art appreciation among the people of that part of the state.

TRAVELING LIBRARIES FOR NEW YORK TEACHERS

A traveling library has been prepared by the New York State Department of Education to serve the needs of elementary teachers and pupils for reference on art and industrial arts. A second collection of books on shop subjects for intermediate grades and high school is being made up by the Division of Library Extension in cooperation with the Division of Vocational and Extension Education.

Teachers working within the State of New York desiring to procure either library are asked to address the Library Extension Division of the University of the State of New York, Albany, asking for an application blank and handbook 8.

PUPILS DESIGN BRONZE TABLET

A bronze tablet bearing the names of all the students and former students of the Worcester Trade School who served in the World War has been designed and executed by the students of that school. The tablet bears the inscription of more than two hundred names. The work has been done under the direction of Loren A. Jacobs, one of the instructors.

INDUSTRIAL TEACHERS OF IOWA REORGANIZE

At the November meeting of the Iowa State Teachers Association, the industrial arts section

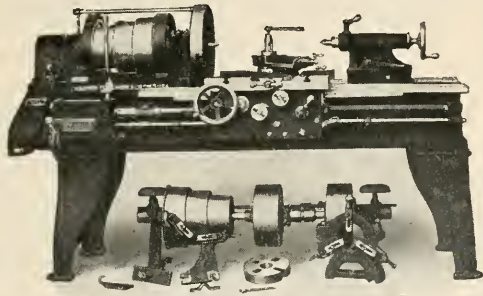

Champion Lathes

A quality engine lathe, accurate, convenient to operate and at a very attractive price to manual training and vocational schools.

Made in four sizes: 13", 15", 17" and 19"

Champion Tool Works

Winton Place

Cincinnati, Ohio

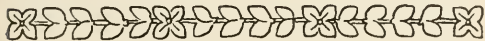

FIELD NOTES—(Continued)

and the industrial arts round table were merged into one organization which will be known from now on as the Iowa Association of Industrial and Manual Arts Teachers. It is to be identified with the I. S. T. A. as an affiliated association. Officers elected were as follows: president, R. H. Barnes; vice president, C. H. Bailey; treasurer, J. L. Jones; secretary, L. G. Bennett, 4020 Cottage Grove, Des Moines, Iowa.

DEVELOPMENT AT DUNWOODY INSTITUTE

A summer cottage was built by the carpentry students at Dunwoody Institute, Minneapolis, last spring. It was dissembled and shipped to Red Wing early in June where it was again assembled and finished by the same class of boys who were sent with the building to complete its construction. The work was done under the direction of H. G. Daskam who at that time was instructor of carpentry.

At the close of the school Mr. Daskam resigned his position. He has been succeeded by A. R. Blomquist who has had many years of trade work and also considerable teaching experience.

W. W. Wentz, formerly of the General Electric

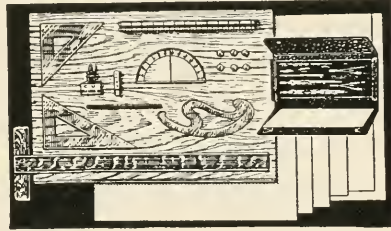

BEST QUALITY OF

DRAWING INSTRUMENTS

Consistent with prices within reach of every student

COMPLETE LINE OF

T. Squares, Triangles, Scales, Drawing Boards, Drawing Papers, Pencils, Thumb Tacks, Etc.

Ask for Illustrations and Prices

THE OLD RELIABLE HOUSE

AMERICAN BLUE PRINT PAPER CO.

445 Plymouth Court, Chicago, Ill.

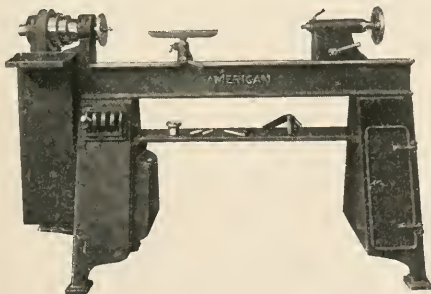

Manual Training Lathe with Motor in Base—24" to 72" Centers

AMERICAN School Equipment

High Quality Machines at Moderate Cost

SAW BENCHES
JOINTERS
PLANERS
BAND SAWS
WOODWORKERS

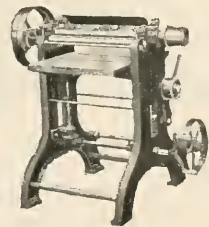

AMERICAN SAW MILL MACHINERY CO.

142 MAIN ST., HACKETTSTOWN, N. J.

OUR NEW
CATALOG
OF
TOOLS
AND
BENCHES

WILL BE READY
IN A FEW WEEKS

We would like to register
your name for a copy.

Simply mention
Catalog No. 235

Since 1848 we have adhered to
one policy—to handle only
the very best in quality

**Hammacher
Schlemmer & Co.**

**Hardware, Tools and
Supplies**

New York Since 1848

4th Ave. and 13th St.

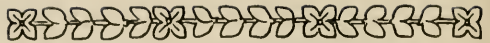

FIELD NOTES—(Continued)

Company at St. Louis, is now an instructor in the electrical department; Mr. Graham who is well experienced in engineering and power work has been obtained for the industrial science department; and Mr. Porter is a new instructor in the printing department. Mr. Milnor of the automobile department has resigned to go into the automobile business. He has been succeeded by L. A. Emerson.

Mr. Gambaro and Mr. Mori are two students from the Argentine Republic who have been studying baking at Dunwoody. Mr. Gambaro has returned to his home country to apply his acquired craft, while Mr. Mori will take additional work before departing.

NEW COURSE ADDED

A course in textiles is offered this year to the senior students of the high school at Sanford, Maine. The course is non-vocational this year but plans are being made by the supervisor, Leslie W. McKay for the development of this work into a complete vocational course. As the textile industry is the dominant one in this city, this course in the schools is looked upon very favorably by patrons and taxpayers.

NEW APPOINTMENTS

NEW DIRECTOR OF CHICAGO ART INSTITUTE

At a recent meeting of the trustees of the Chicago Art Institute, Robert B. Harshe was elected director of the Institute to succeed George W. Eggers, who, as announced in the November issue of the *Manual Training Magazine*, has resigned and gone to Denver as the director of the Denver Art Association.

MR. TAYLOR RECEIVES PROMOTION

As number one on a recently established eligible list, Louis Taylor of Manual Training High School has been appointed Supervisor of Mechanical Drawing in the evening elementary, trade and high schools by the Board of Education, City of New York. This position covers the supervision of the mechanical, structural, architectural, and trade drawing classes in all of the evening schools of Greater New York.

Mr. Taylor has been connected with the evening, vocational, and high schools for the past twelve years. He was formerly chairman of the department of drawing at the Brooklyn Vocational School and also the Brooklyn Evening High School.

H. H. BRAUCHER GOES TO ILLINOIS

H. H. Braucher, director of manual arts at the State Normal School, Emporia, Kansas, is spending the present year at the University of Illinois. He

CRANE'S "JUNIOR" BENCH SAW

This high grade, accurate and fully guaranteed machine is constructed entirely of metal. It is well adapted to both wood and metal sawing.

Table top is 10" x 13" and can be tilted on either side to any angle up to 5 degrees for drafting patterns, etc. Top can also be adjusted to any height for grooving, etc. Slot is wide enough to accommodate 3-16" grooving cutter. Weight is 40 pounds. Other details on request. I also manufacture a full line of plain and ball-bearing motor-driven bench saws and disc sanders, etc. Send for circulars.

HAROLD G. CRANE,

Adrian, Michigan

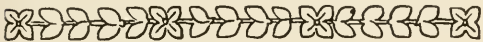
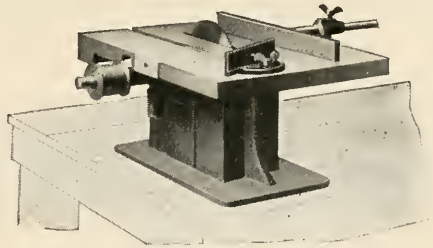

FIELD NOTES—(Continued)

is an instructor in industrial education and has charge of such work in the University High School for the year. He is enjoying the first opportunity to teach in the shops of the new building for education, the equipment for which was planned by Professor Griffith before he went to the University of Wisconsin.

MILLER GOES TO MICHIGAN

H. W. Miller, who is known among school men as the author of the book *Mechanical Drafting* has

GLUING CLAMPS



We make the best clamps for every purpose; ask for *Bulletin 11-B*

Steel Bar
Column

Wood Bar
Mitre

THE BLACK BROS. CO.
Mendota, Ill. U. S. A.

"STAR" LATHES



11" x 4'
"Star" Quick
Change Lathe

Also Furnished
in 13" Size

The Last Word in Quality, Efficiency, Service

THE SENECA FALLS MFG. CO., Inc.
SENECA FALLS, N. Y.

For Mid-Year Adoption—

- Grammar Grade Problems in
Mechanical Drawing—*Bennett*.
For 7th and 8th grades..... 44c
- Mechanical Drawing for Beginners
—*Bailey*.
For Junior High classes..... 68c
- Problems in Mechanical Drawing—
Bennett.
A one-year text for 9th grade.... \$1.20
- Mechanical Drawing Problems—
Berg and Kronquist.
A two-year text for high schools.. \$1.28
- Mechanical Drafting—*Miller*.
For advanced high school classes . \$2.00
- Progressive Steps in Architectural
Drawing—*Seaman*.
For high school classes..... \$1.80
- Architectural Drawing Plates—
Elwood.
Short course for high schools..... 60c
- Essentials of Woodworking—
Griffith.
For junior and high schools..... \$1.44
- Woodwork for Beginners—*Griffith*.
For grammar grades and junior high, 8+c
- Tool Processes in Woodworking—
Laughlin.
For beginners in grammar or high
schools..... 88c
- Woodwork for Secondary Schools—
Griffith.
For advanced high school classes . \$2.64
- Workshop Note-book—Woodwork-
ing—*Greene*.
For beginning classes in grammar
or high school..... 28c
- Billed to teachers and supervisors
on approval for adoption.*

The
Manual
Arts Press
Peoria, Illinois

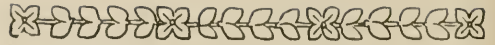

FIELD NOTES—(Continued)

accepted the position of Professor of Mechanism and Engineering Drawing in University of Michigan. Before the war Professor Miller was Assistant Dean of the College of Engineering and head of the department of engineering drawing, University of Illinois.

THE KANSAS CITY MEETING

AS the January issue of the *Manual Training Magazine* makes its appearance it will be time for its readers to pack their grips and start for the annual convention of the National Society for Vocational Education which will be held in Kansas City, January 5, 6 and 7. An advance program has just been received, showing in detail the many general and sectional meetings which will be held. A great number of the leaders in the field of vocational education of all types—men who are actually making progress in this field—will appear on the program to tell the rest of us what they have done and by what methods they have done it.

A one and one-half fare for the round trip on the *certificate plan* will apply to persons going to the convention and to their dependents. A certificate must be asked for when the ticket is bought. Upon the arrival at Kansas City one should have the certificate endorsed. It is important that people who live near Kansas City call for this certificate even tho the saving may be very little, since the reduction is dependent upon the sale of 350 tickets of this particular type. Tickets may be bought from January 2 to 7; with January 11 as the final return date.

TRADE NOTES

WROUGHT HARDWARE

A NEW general catalog has recently been issued by The Stanley Works of New Britain, Connecticut. It is devoted to *Wrought Hardware* manufactured by the Company and is as fine a catalog as we have seen.

The subject-matter is handled with extreme care and completeness, and the book as a whole is a

TOOLS

For Manual Training Shops.
Send your inquiries to and get the especially
low prices quoted by

MONTGOMERY & CO. Inc.,
105 Fulton Street New York City



WE ARE GENERAL AGENTS FOR THE WORLD
FAMOUS GENUINE RICHTER

DRAWING INSTRUMENTS

They represent the highest standard in quality
and have no equal anywhere.

*Write and give requirements.
Complete circular showing sets and separate tools
mailed on request.*

U. S. BLUE PRINT PAPER CO.
CHICAGO, ILLINOIS

SHEET METAL WORKING TOOLS

For Manual Training Courses

WE have had many years of experience in fitting out Manual Training Schools with the necessary machines and tools for Sheet Metal Working Courses. If your school has or contemplates such courses, avail yourself of our experience and facilities.

Niagara Machine and Tool Works
Buffalo, N. Y., U. S. A.

NIAGARA

"JORGENSEN" Hand Screws

Withstand the abuse of
inexperienced hands

Steel Spindles
Steel Nuts
Hard Maple Jaws

**Adjustable
Clamp Co.**

216 N. Jefferson St., Chicago



The best is none to good for the boys—

Specify **GREENLEE VISES**

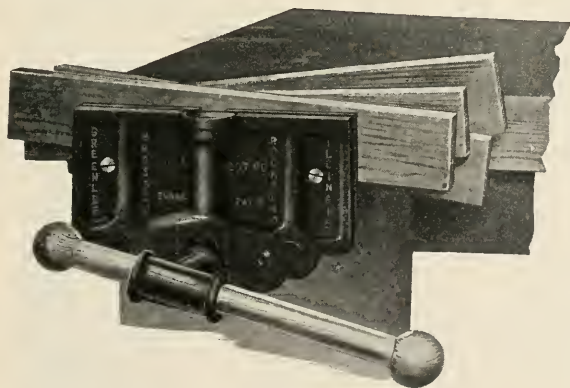

A Greenlee Cushion Grip Vise in action

BECAUSE
they have

Continuous screw action in
both directions.

Free turning of the screw in
either direction.

Quick action available at any
handle position.

A screw not mutilated by long
grooves.

A complete nut fully engaging
the screw.

Simple, strong and positively
connected parts.

Ask for descriptive booklet

GREENLEE BROS. & CO.

Rockford, Illinois

Marqueterie, Inlay Borders and Purflings for

Manufacturers and Vocational
Schools

Insets for Trays, Panels, Cabinets, etc. carried in stock.
Natural and Transformed Veneers in great variety.
Lines in Holly, Satinwood, Box, Mahogany and Black

J. BERNARD CO.

422 to 30 East 53rd St. New York

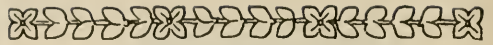

TRADE NOTES—(Continued)



fine example of catalog making. It contains 376 pages, size 6½" x 9½", printed on high-grade enameled paper, profusely illustrated, and well and attractively bound in cloth.

SALES CONVENTION

S. C. Johnson & Son, the well-known manufacturers of artistic wood finishes, recently held a sales convention at their factory in Racine, Wisconsin. Attending the convention were salesmen from all sections of the country. An interesting program for entertainment as well as study and business was carried out during the five days' session. One

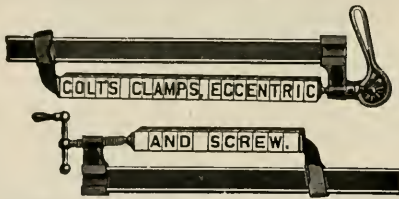

Forty styles of Quick Acting Clamps for the
Worker in Wood, Cement and in the
trades generally.

Your dealer will supply you.
Ask for catalog No. 296.

BATAVIA CLAMP CO.

237 Center Street BATAVIA, N. Y.



Manual Training Bench, No. 16

which is furnished with one Abernathy Rapid
Acting Vise, and with one drawer.

Ask for our new Catalog No. 27

C. CHRISTIANSEN
BENCH MANUFACTURER

2814 W. 26th St. CHICAGO, ILL.

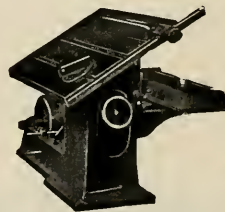

Crescent Wood Working Machines

are the tools your students will eventually use so give them the opportunity now of learning about this splendid line of wood working machinery.

Send today for our catalog of hand saws, jointers, saw table, shapers, variety wood workers, planers, planers and matchers, cut off saws, disk grinders, borers, hollow chisel mortisers, Universal wood workers.

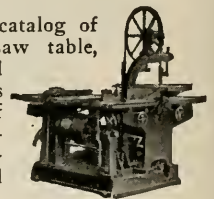

The Crescent Machine Co.

46 CHERRY ST. LEETONIA, OHIO

MAYDOLE HAMMERS

THE WORLD'S STANDARD

Highest Quality Steel Handled Hammers
Guaranteed First-Class in Every Respect

*Booklet of Useful Information
for each student on request.*

The David Maydole Hammer Co.
Norwich. N. Y., U. S. A.



Lumber

All Kinds of Domestic and
Foreign Woods

Frank Paxton Lumber Co.
Kansas City, Kansas

Give Your Pupils SHOP-WORK THAT PAYS

Let the Boys Build Phonographs

Imagine the pride and joy of your pupils in building *their own phonographs* (equal in quality to high-priced standard machines) either to sell or take home as a source of lasting pleasure. Think how this project will add to your popularity as an instructor. Building phonographs is easy, by our methods, yet it demands precision and delicacy of workmanship, the very points always emphasized in shop practice. *Send 10c for fine illustrated catalog*

and full information about our co-operative plan for manual training teachers. We plan the work for you. We supply blueprints, tone-arms, motors, case material and all accessories at lowest prices. Detailed instructions furnished. Materials best obtainable, fully guaranteed. Our machines play any make record. Write us TODAY.

HOOSIER MANUFACTURING & SUPPLY CO.
PHONOGRAPH SUPPLY DEPT.

315 Baldwin Block, Dept. A.

Indianapolis, Ind.

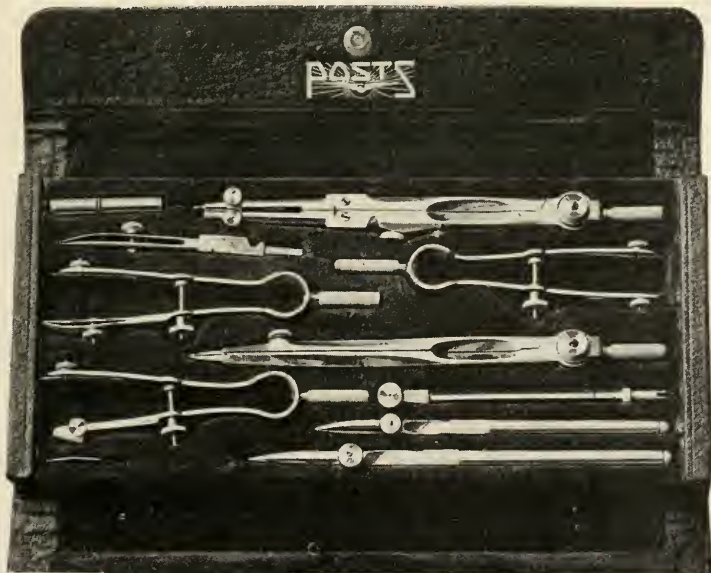

Special Offer Unusual Bargain

No. 1070C Set in
Case Ruling Pen
Compass, \$2.40.

No. 1071½C Set in
Case Ruling Pen,
Bow Pen, Hair-
spring Divider
Compass, \$3.00.

No. 1073C Set in
Case Ruling Pen,
Bow Pencil, Bow
Pen, Hairspring Di-
vider Compass, \$3.30

No. 1075C Set in
Case Ruling Pen,
4½", Ruling Pen
5½", Bow Divider,
Bow Pencil, Bow
Pen, Hairspring Di-
vider Compass, \$3.90

POST PAID

LIMITED QUANTITY FOR IMMEDIATE ORDER ONLY

THE FREDERICK POST CO.

Salesrooms

CHICAGO

Main Office and Factory

319 S. Wabash Avenue.

3635 No. Hamlin Ave., P. O. Box 803

CUSHIONS



Stuffed Cushions
Spring Cushions
Upholstery
Supplies

Write for Descriptive
Circular and Complete
Information for ordering

Illinois Valley Awning and Tent Co.

Formerly Kunkle-Karl Co.

126 N. Washington St. Peoria, Ill.

L-U-M-B-E-R

We Specialize in
Manual Training Lumber

No order is too large or too small to receive
our careful attention

John S. Benedict Lumber Co.

419 N. Halsted St. CHICAGO

VENUS PENCILS

From the softest grays to the deepest
blacks the illustrator finds his best
expression in the superb VENUS—the
perfect pencil.

17 black degrees, 3 copying

For bold, heavy lines . 6B-5B-4B-3B
For writing, sketching 2B-B-HB-F-H
For clean, fine lines, 2H-3H-4H-5H-6H
For delicate, thin lines . 7H-8H-9H

American Lead Pencil Co.

219 Fifth Ave., N. Y.
Dept. A

The largest selling
Quality pencil in
the World

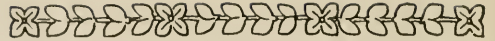

TRADE NOTES—(Continued)

event was an entertainment and dance for all employees and their families, at which time a bonus of \$76,810.64 was distributed among 243 employees, in proportion to their length of service and salary or wages received. This practical co-operation of the company with its employees is a mark of modern business methods and reflects in the quality of the goods manufactured and to the credit of the Company.

THE BAND-SAW

The Band-Saw is the title of a book published by The Simonds Manufacturing Company of Fitchburg, Mass. This book gives valuable information not otherwise obtainable. Having been saw makers since 1832, they are in position to give with authority facts regarding the care and use of the band-saw. Altho a small book (64-page, size 4 1/4" x 6") it contains eleven chapters as follows:

- I—Superiority of the Band-Saw.
- II—Making Band-Saw Steel.
- III—Making a Band-Saw.
- IV—Rolling and Tensioning Wide Band-Saws.
- V—Leveling a Band-Saw.
- VI—Brazing a Band-Saw.
- VII—How to Tension a Band-Saw.
- VIII—Band-Saw Speed and Strain.
- IX—The Band-Saw Mill.
- X—Fitting and Running Small Band-Saws.
- XI—Safety First with Small Band-Saws.

The book is illustrated with line drawings and is printed on enamel paper and is bound in cloth. It is priced at \$1.00. Supervisors and teachers of woodworking operating a band-saw can secure a copy free by mentioning the *Manual Training Magazine* and addressing their request to The Simonds Mfg. Co.

Build Your Own PHONOGRAPH

Instructive—arouses pupils' enthusiasm—provides one of the best problems in cabinet making.

Let Your Pupils Build
Choraleon Phonographs

We furnish plans, blue prints, motors, tone arms, case material—in fact, everything required. Full instructions. Choraleon's have fine tone. Play any record. Ask for particulars.



CHORALEON PHONOGRAPH CO.
121-7th St., Elkhart, Ind.



BOOK NOTES

A NEW book on *Elementary Industrial Arts* by Leon L. Winslow is soon to be issued by The Macmillan Company. In this book Mr. Winslow attempts to carry out the principles underlying the teaching of art and industry set forth in Dr. Bonser's "Some Fundamental Values in Industrial Education." It aims especially to conform to Dr. Bonser's definition of industrial arts as "the distilled experience of man in his resolution of natural materials to his needs for creature comfort, to the end that he may more richly live his spiritual life."

This book will provide instruction in industries appropriate for boys and girls in the upper elementary grades. It will combine drawing and art with construction, and these with other industrial subject-matter. The table of contents indicates that the book will include chapters on bookmaking, papermaking, the manufacturing of baskets and boxes, brick and tile making, cement and concrete work, the textile industries, copper working, iron and steel construction, the soap industry, the glass industry, and woodworking.

ANYONE who has been looking for a brief, practical, understandable treatment of electricity and the more common electrical appliances will find what they want in *Practical Electricity for Beginners* by Willoughby, which has just been issued by The Manual Arts Press. It is written especially to meet the need for a textbook in junior high schools, grammar grade classes, continuation schools, or other schools teaching the elements of electricity to beginners; it is usable, also, in the home, not only by boys, but by adults who want to know what is inside of the electric flatiron, or behind the push button of the electric switch.

In order that the book may be especially adapted to school use, each chapter closes with (a) a summary of principles set forth in the chapter, (b) a list of questions on the text of the chapter and (c) a list of suggestions for applying the instruction given in the chapter. The book is not, however, a book of problems, but a real textbook, giving the student in electric construction and repair work just the fundamentals he needs to know to solve his problems. The approach to the subject is from the concrete and visible rather than from the

theoretical and invisible. The explanations are very clear and simple.

The book has been in preparation for more than a year. It has been modified and parts of it re-written several times in order to meet the particular needs of beginners who have the limited background of education of a junior high school student. It has been tested out in classes by the author and has proven itself to be effective.

The book is illustrated by sixty diagrams drawn by the author.

NO ONE appreciates the fine points in a good book quite as much as the author of another good book. Here is what one author writes about *Art and Education in Wood-Turning*.

"I think Mr. Klenke has done a fine piece of work, and the book surely is attractive in appearance. Both the half-tone and line cuts are very clear. I particularly like the rounded corners on the border of the line cuts. I am pleased to see another man present his subject in accord with the general plan of construction that I followed in *Farm Blacksmithing*.

"While it is true that you published Mr. Payne's book on *Art Metalwork* some time ago, I think Mr. Klenke might be considered a pioneer in building a shop project book in which the technic is sound and the art side given special attention and prominence. I am wondering if there is not some man now who could do the same for furniture construction and design as executed in schools, and possibly another who could help make some of the first-year shop projects more beautiful. There is much room for improvement in both groups, and in these days of the high cost of lumber, we have additional reason for spending more time on one object, and additional reason for making it sound and beautiful.

"Mr. Klenke seems to have covered practically all (certainly all of the common) tool operations and practices that a high school boy would use; and with the illustrations, and instructions for each article, they seem quite complete.

"I am surely pleased to get this book, and I am sure it fills a long-felt want. I hope, also, that it will be an inspiration to others to 'go and do likewise.'"

No More Loose Handles

Don't take chances with Hammers with ordinary Wedges when you can now secure the **UNCLE SAM BRAND** Hammers with the new **VAUGHAN'S EXPANSION WEDGE**.

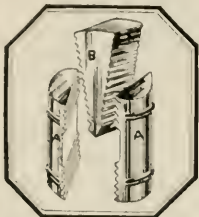

If the handle shows any tendency to become loose simply set the Wedge (B) a notch or two deeper between the pins (A) and a tight handle is assured.

UNCLE SAM HAMMERS are the only Hammers that have been approved by the **UNDERWRITERS' LABORATORIES** and each Hammer has the Underwriters' Label. It took 900 lbs. more pressure to pull the handle through the head with the **VAUGHAN'S EXPANSION WEDGE** than with the Ordinary Wedge. Uncle Sam Hammers are made in all patterns and sizes. *Write for description booklet No. 10 which describes this line in detail.*

VAUGHAN & BUSHNELL MFG. CO.

2114
Carroll
Ave.



Chicago.
U. S. A.

PUPILS SHOP ACCOUNTS

do Not Trouble Instructors Using Our Systems. Pupils do all the Recording Accurately and "to date." All Accounts are Kept

AUTOMATICALLY

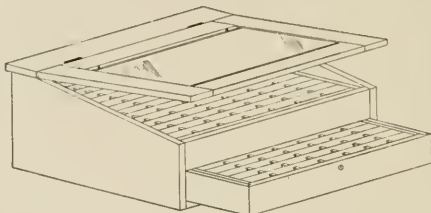

One of our Many Designs of the Industrial Arts Record. Built to Handle Any Number of Pupils.

Priced \$15 to \$85 with Liberal Discount in Quantities.

Let your problem be our burden

MANUAL ARTS SPECIALTY CO.

"Makers of Shop Efficiency"
ATCHISON, KANSAS

Buffalo Combination Woodworker

Twelve
machines
in one

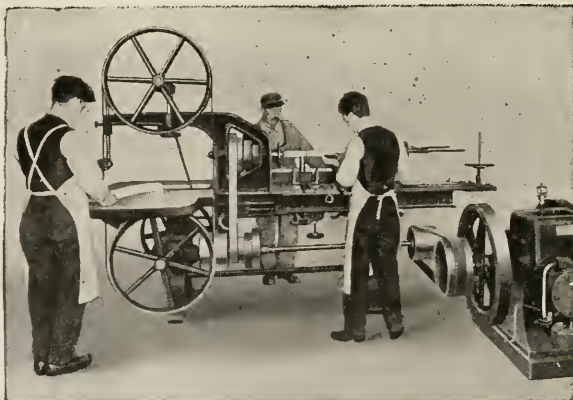

Three
men
can work
at one
time
without
inter-
ference.

With this machine it is possible to give a complete training in woodworking without an elaborate machine equipment.

Bulletin 360 will show how a small appropriation can be made to work wonders.

BUFFALO FORGE COMPANY
BUFFALO, NEW YORK

MANUAL TRAINING MAGAZINE

EDITORS CHARLES A. BENNETT, Peoria, Illinois.
WILLIAM T. BAWDEN, Assistant to Commissioner of Education, Washington, D. C.

ASSOCIATE ARTHUR D. DEAN, Professor of Vocational Education, Teachers College, New York City.
EDITORS: FRANK M. LEAVITT, Associate Superintendent Public Schools, Pittsburgh, Pa.
WILLIAM E. ROBERTS, Supervisor of Manual Training, Public Schools, Cleveland, Ohio.

Business Manager: L. L. SIMPSON.

Published monthly by The Manual Arts Press, 237 N. Monroe St., Peoria, Illinois.

Subscription Price, \$1.50; Canada, \$1.80; Foreign, \$2.00. Single Copies, 25 cents; Foreign, 30 cents.

Subscriptions, remittances and manuscripts should be sent to THE MANUAL ARTS PRESS, Peoria, Illinois.

ANNOUNCEMENT

The March number of this Magazine will be a Special Industrial Art Number. It will present to our readers some recent statements on the need of giving more attention to art in industry and in education, and it will give some practical suggestions for teachers of industrial work.

—THE EDITORS.

CONTENTS

SELECTION AND TRAINING OF INSTRUCTORS FOR VOCATIONAL SCHOOLS AND SHOPS.....	<i>Beverly B. Burling</i>	261
THE OKMULGEE HIGH-SCHOOL (Illustrated).....	<i>Charles A. Bennett</i>	265
PAPER DRESS FORM MAKING TAUGHT IN SCHOOL (With Photograph).....	<i>H. W. Roberts</i>	271
OUTSTANDING FEATURES OF NATIONAL SOCIETY CONVENTION.....	<i>E. E. Ericson</i>	272
A CROSS-SECTION OF THE MILWAUKEE CONVENTION.....	<i>Charles A. Bennett</i>	275
EDITORIAL REVIEW FOR THE MONTH.....		278
New Development in Detroit.		
A POINT OF VIEW.....	<i>Arthur Dean</i>	281
WASHINGTON CORRESPONDENCE.....	<i>William T. Bowden</i>	283
The Technic of Army Training—Educational Surveys.		
IN FOREIGN COUNTRIES.....		285
Encouraging Start made by the London Continuation Schools—Proof of the value of German Continuation Schools—A New Trade School in Albania—Importance of Fundamental Education.		
PROJECTS, PROBLEMS AND NOTES.....		287
Fiber Chair Seats—Automobile Practice Wiring—The Industrial Arts Departments and the School Bazaar—Child's Arm Rocker—Gumwood Chest—Stone Building Blocks—Matching Mahogany Finish—Hammock Hook—Milk Bottle Holder and Pedestal.		
CURRENT PUBLICATIONS.....		294
FIELD NOTES.....		IV
Around New York—Meeting of Illinois Manual Arts Association—In California—In Boston—Southeastern Items—From the Southwest—New York School Crafts Club—Mechanic Arts Teachers in Session—Government Needs Workers for Rehabilitation—Items of Progress—Appointments.		
TRADE NOTES.....		XXVII
BOOK NOTES.....		XXXVII

This Magazine is kept for sale at McClurg's in Chicago, and Brentano's in New York.

Field Notes + Travel Notes 1915-1916 Xy - Xx



FIELD NOTES

AROUND NEW YORK

AMONG the visitors during Continuation School week at the Brooklyn School were Director Stevens of Pratt Institute, who spoke on the value of good reading, and Charles Smith, co-ordinator for the Board of Education, who emphasized the need of education for business. Director Mark of Hefley Institute addressed an assembly on "Commercial Education," and related some of his observations and experiences. District Superintendents James J. Reynolds and Thomas O. Baker gave good advice to the boys, and stressed the need of education for work.

ABOUT THREE HUNDRED MEMBERS of the School Art League were entertained at a luncheon on Saturday, December 10, by one after-dinner speaker of the age of twelve, and three others only a little older. Master Klein told of the weekly meetings held at the Metropolitan Museum, and how Miss M. Rose Collins of the League, talked to them, drew for them, and told them stories of Egyptian kings, Greek heroes, etc. Miss Bertha Kraemer and Miss Alma Feikel, high school pupils, told of the League's work in the high schools, and Walter B. Dutcher, a graduate of the Manual Training High School, Brooklyn, described the League's scheme of scholarships, which enables from thirty to forty pupils each year to receive a year of post-graduate art instruction. "Over 100 students," said Mr. Dutcher, "have already enjoyed these scholarships, and many are now out in the trade earning high salaries."

Besides the youthful speakers, the League had several grown-up speakers. Dr. John H. Finley spoke on "The Need of Democratic Art Teaching in America." Hamlin Garland and Wm. J. Ivins, Jr., reviewed the important work being done by the School Art League in bringing a love of beauty to many thousands of our city children in the elementary and high schools. Miss Jane Peterson, the well-known painter, spoke of the rise of artistic feeling thruout the country. This she ascribed to the work being done by the art teachers of the public schools.

THE NEW YORK CITY VOCATIONAL GUIDANCE ASSOCIATION has held two conferences on (1) the need for vocational guidance in the school, and (2) the need for vocational guidance in the industry. Both were well attended and very interesting. For the present season the Association is planning the following undertaking:

(1) Vocational guidance survey of New York city.

- (2) Evaluation of trade tests.
- (3) Evaluation of commercial tests.
- (4) Co-operation with the Commission for Revision of Child Welfare Laws.

The February meeting, to be held on the third Tuesday of the month, will be an experience meeting, at which institutions doing vocational guidance work will relate what they are doing now, what they intend to do, and what their problems are.

PART-TIME AND EVENING PROGRAMS and courses in house management are among the important topics that were considered at the annual meeting of the Federal Board of Education for the Atlantic region held at the Hotel McAlpin. Agricultural education was considered at the opening session, which began with a discussion of farm enterprises, led by C. H. Schopmeyer of the United States Department of Agriculture. A. K. Getman, agricultural supervisor under the state director of vocational education, outlined a plan for scientific potato raising.

—W. H. DOOLEY.

MEETING OF THE ILLINOIS MANUAL ARTS ASSOCIATION

A STATE meeting of the Illinois Manual Arts Association which was held in Springfield, December 29, proved to be of great interest to those who attended. The entire program was centered around the problems of the junior high school and the continuation school.

In the morning session M. F. Kavanaugh, Supervisor of Industrial Arts gave a talk on the topic, "Record Systems for Industrial Arts." In this talk was pointed out the necessity for both the supervisors and teachers to keep checks and records with reference to material used, conditions of tools and equipment, and the work of the student from year to year. That a system of records eliminates waste both in materials and in energy of students was emphasized in this discussion; also that a system of records serves as a stimulus for the teacher to be more systematic in his shop teaching.

The second topic was presented by E. A. Fritsch of the South Side Continuation School, Chicago, who had chosen for his subject "The General Shop." One point emphasized here was that the industrial work is not the only type of work (and perhaps not the most important type) in the continuation school. The speaker, further, indicated that the industrial work in the continuation school does not have to be trade work to be of importance. To build useful citizens is the greatest function of the continua-

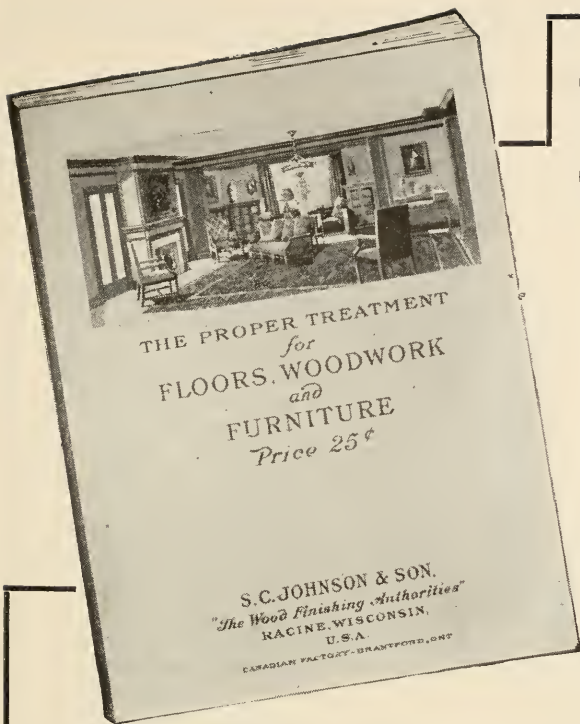

Get Your Copy of This Book

It's the best book ever published on Artistic Wood Finishing and should be in the hands of every Wood Finishing Instructor. It is full of valuable information on finishing all wood—soft and hard. Considerable space is devoted exclusively to the finishing of manual training models. It's the work of experts—illustrated in color.

How To Get It FREE

Write us (mentioning the name of the firm from whom you buy paints, varnishes, etc.,) and we will gladly send you our book "The Proper Treatment for Floors, Woodwork and Furniture" free and postpaid.

JOHNSON'S ARTISTIC WOOD FINISHES

Johnson's Artistic Wood Finishes are particularly adapted for manual training work as they may be applied by the youngest and most inexperienced pupils with good results. Johnson's Artistic Wood Finishes are standard for manual training—they are being used all over the United States and Canada for this purpose.

Our line of Artistic Wood Finishes is complete—it includes:

- | | |
|------------------------------------|---------------------------------------|
| <i>Johnson's Prepared Wax</i> | <i>Johnson's Perfectone Undercoat</i> |
| <i>Johnson's Wood Dye</i> | <i>Johnson's Perfectone Enamel</i> |
| <i>Johnson's Crack Filler</i> | <i>Johnson's Electric Solvo</i> |
| <i>Johnson's Paste Wood Filler</i> | <i>Johnson's Varnish</i> |

You will find this entire line described in our book. Any time specific information is desired, or whenever you want specially finished wood panels, do not hesitate to write us. We solicit correspondence with Manual Training Instructors.

Mail attached coupon for this authoritative book on Wood Finishing.

S. C. JOHNSON & SON, Dept. MT2, Racine, Wis.
"The Wood Finishing Authorities"
 Canadian Factory, Brantford

S. C. JOHNSON & SON

Racine, Wis., Dept. MT2.
 (Canadian Factory, Brantford)

Please send me free and postpaid your authoritative book on Artistic Wood Finishes for use in Manual Training Work.

The best dealer in paints here is.....

My Name.....

My Address.....

City and State.....



FIELD NOTES—(Continued)

tion school and to this end all the subjects should point the way. With this aim in view, the general shop, where many different kinds of activities are carried on at one time, aims first of all at stimulating interest within the pupil and make him desire to do some useful work in the shop.

Another impression made in this talk was that, at the South Side Continuation School, the idea of educating the pupil away from the kind of work he is doing and into what might seem to be an easier or generally more desirable occupation is not prevalent. The great purpose appears to be to fit the pupil to better perform the work which he has chosen to follow. For this reason a large variety of work is going on in the general shop under the supervision of the teacher, and an attempt is made to interest students in something which will tend to broaden, enrich, and dignify the work which they are pursuing.

At the close of this talk the discussion was opened by E. E. Ericson of The Manual Arts Press, who emphasized the value of a student's shop record card upon which the daily grade of the pupil's work would be registered at the close of each shop period. It was stated that these cards are most effective when kept in open view before the students and collected and distributed by the students themselves. A further point was made that this card stimulates fairness and regular grading by the teacher and is more reliable, and fairer to the student than when only occasional grades from memory or from general impression are recorded.

In the afternoon meeting C. A. Hoffman, who is in charge of evening classes in Lane Technical High School spoke on the subject of "Continuation School Work for Adults." Here the significant statement was made that the evening schools compose the greatest of all agencies for the Americanization of both the foreigners and of the native born who are foreign to the true principles of democracy. That the people are availing themselves of the opportunities of the evening school is evidenced by the fact that there is always a waiting list at the Lane Technical High. This waiting list has at times run up to several hundred applicants for one course, A short but interesting history of the Chicago evening schools was given showing that in 1861 W. H. Wells, then superintendent of schools, recommended that an unclassified school be established where the foreign element in particular could get such instruction as would better fit them for the duties of life and for the obligation of citizenship. In 1862 the first evening school was established. There are now in Chicago fourteen high schools and

one commercial high school engaged in evening school work with an attendance of 13,000 and an additional 9,000 students attending the classes in the grade schools.

L. P. Elliott, dean of vocational education, Bradley Polytechnic Institute gave a short talk in which he strongly emphasized the practical and useful in manual arts education. He stated that the lines between manual arts, industrial arts, vocational education, etc., become insignificant when the work is done under wide awake, practical instructors. He also pointed to the oncoming of the great problem of rehabilitating the men disabled in industry, and suggested that means must be taken to meet this problem.

A paper was then read by Albert F. Siepert, dean of industrial teacher training, Bradley Polytechnic Institute, concerning the successful work done in the continuation schools by R. R. Neely, principal of the continuation schools, Peoria. Mr. Neely has succeeded in basing a large percent of the academic work of the continuation school upon real situations in the life of the pupils. A book on practical arithmetic has recently been published by Mr. Neely which presents the subject of arithmetic altogether with this life experience of the pupil in mind.

Officers elected for the coming year were: President—L. M. Cole, James Millikin University, Decatur; Vice President—L. E. Wharry, Bradley Polytechnic Institute; Secretary-Treasurer—M. F. Kavanaugh, Springfield.

IN CALIFORNIA

DURING the Christmas vacation practically all the counties of Southern California participated in a united convention, largely under the auspices of the California Teachers' Association, Southern Section. While in the general convention no special department was devoted to vocational education, industrial arts or manual training, there was not a single general session in which one or more of these subjects was not given prominence in discussions. Chief among the speakers who devoted some time to the various mechanic arts subjects were Dr. Charles A. Prosser and our own Dr. Edwin R. Snyder, state commissioner of vocational education.

DR. PROSSER SPEAKS IN CALIFORNIA

Dr. Prosser with his characteristic force and impressive style, delivered two main addresses, one on "The Rights of Childhood" and the other entitled "The Old and the New Apprenticeship." In

Industrial Correspondence University

PHILADELPHIA, PA.

ANNOUNCEMENT

PRESIDENT T. J. FOSTER takes pleasure in advising all who are interested in industrial and vocational affairs that the Industrial Correspondence University is prepared to enroll students for the best Mechanical Drawing, Architectural Drafting, and Blue Print Reading Courses that have ever been offered to the public.

Associated with President Foster, as Dean of the University, is Harry S. Bitting, President of The Williamson Free School of Mechanical Trades. Mr. Bitting has selected as his associates in the preparation and arrangement of all the technical courses, Mr. James A. Pratt, Mech. E., Director of The Williamson Free School of Mechanical Trades, and Frederic S. Crispin, C. E., Professor of Mechanical Drawing, Germantown High School, Philadelphia, Pa.

Mr. Pratt, personally, recently completed our Blue Print Reading Course which is a masterpiece of its kind, and we unhesitatingly recommend it, not only for students, apprentices, and shop workers, but for every teacher in the vocational educational field.

By our original and unique plan of sale all of our courses will be sold in units as Freshman, Sophomore, Junior, and Senior. A student enrolling will not be required to pay cash or part payment for more than a single unit at a time. Should he fail to complete this unit, or decide not to go on with the work after he completes it, it will not be necessary for him to make additional payments. After completing the first unit he may go on with the second, and so on, to the completion of the course.

In addition to the regular student enrollment plan of sale, either for cash or on the part time plan, we have decided to sell the courses at a very special price to teachers, without service, and at a still more moderate wholesale price, in lots of ten or more, to school organizations, without service, by which we mean that it will not be necessary for them to send in lessons for correction.

If interested, either as an individual or from a teacher's or principal's viewpoint, with the thought of adopting the courses, check the coupon at right and mail it to us, after which you will promptly receive full information.

Department M,
Industrial Correspondence University, Inc.,
1504 Locust Street, Philadelphia, Pa.

Without expense or obligation on my part, please give me full information concerning the course which I have marked X.

- | | |
|--|---|
| <input type="checkbox"/> Blue Print Reading
(Building Trades) | <input type="checkbox"/> Blue Print Reading
(Blacksmith) |
| <input type="checkbox"/> Blue Print Reading
(Mechanical Trades) | <input type="checkbox"/> Tracer |
| <input type="checkbox"/> Blue Print Reading
(Plumbing and Pipe
Fitting Trades) | <input type="checkbox"/> Mechanical Draftsman |
| <input type="checkbox"/> Blue Print Reading
(Structural Iron
Workers) | <input type="checkbox"/> Architectural Draftsman |
| <input type="checkbox"/> C. P. A. Exams. | <input type="checkbox"/> Employment Manager |
| | <input type="checkbox"/> Expert Accountant |
| | <input type="checkbox"/> Cost Accountant |
| | <input type="checkbox"/> Auditor |
| | <input type="checkbox"/> Commercial Law |
| | <input type="checkbox"/> Financial Independence |

Name

Street and Number.....

City and Post Office.....State.....



FIELD NOTES—(Continued)

his discussion of the former topic, Dr. Prosser laid stress on two rights. The first of these he declared was "the right to be well born." In enlarging upon this topic Dr. Prosser told of the large number of persons who are congenitally subnormal, idiotic, insane, and otherwise mentally and physically feeble. No education, however wisely designed and carefully given, could possibly bring persons born with congenital moral, mental or physical deficiencies to a stage of development which would make them self-supporting and self-controlled useful members of society.

The second right emphasized by Dr. Prosser in his discussion of "The Rights of Childhood" was "the right to be properly adjusted to his environment." In a democracy we all believe in that right and accept it without question. And we believe that by giving uniform education to all we thereby give all an equal opportunity. But there is where our fundamental mistake is made. Children are born with varying aptitudes. All are not given to book learning. Therefore a book-learning school education is not suitable to all. Nor does it provide proper adjustment to the environmental conditions of all children, for these conditions also differ.

Thus, while Dr. Prosser religiously avoided mentioning with due emphasis the need for vocational education, industrial arts, home making and agriculture, he was thruout this entire address implying that they were for certain boys and girls highly important and for the country as a whole absolutely essential.

In his discussion of "The New and the Old Apprenticeship," Dr. Prosser devoted himself to a presentation of the "golden age of apprenticeship" as it was known to the craftsmen of the Elizabethan period in England as compared to the present day attempts to provide some semblance of that apprenticeship under modern times. In the Elizabethan age the craftsmen were recognized to be of such great importance to the maintenance of England's commercial position that laws were made to protect the craftsmen in their enterprises and to assist them in maintaining their already well established plan of accepting and training apprentices.

Our modern attempt to provide a substitute for the now decadent old-time apprenticeship is seen in the establishment of part-time schools all over the country. This work in the opinion of the speaker is the solution to the problem of our lack of mechanically skilled and industrially intelligent craftsmen. But the meager four hours now allowed for the part-time education, he said, is only a beginning.

It is but the entering wedge. Soon it will be eight hours and then twelve and, he added, "if you will ask me where the advance in hours allotted to part-time education will stop, I will be obliged to say I don't know." That we cannot continue doing as we are, Dr. Prosser felt assured. To do so spells economic ruin.

The Part-time Act of California Dr. Prosser declared to be one of the best if not the best on the statute books of any state. The feature of the act to which he alluded as most unusual and at the same time exceptionally commendable is that part of it which provides, in addition to the usual continuation of regular school work, trade extension and trade preparation courses, guidance in both social and vocational matters.

Dr. Snyder's talk on "Things Worth While," was as usual very practical and to the point. He emphasized the need of careful investigation before any particular kind of school work is undertaken. Those things are most worth while which have the greatest application to life. But what is worth while to one pupil is not necessarily equally worth while to all others. Each case must be judged on its own merits and each given what it needs.

BEN W. JOHNSON RETURNS TO THE PACIFIC COAST

B. W. Johnson is again with us in California. He first came to us in 1917, when, as the Pacific Coast Agent for the Federal Board for Vocational Education he opened offices in San Francisco. For a year or so since he severed his connection with the Federal Board for Vocational Education, Mr. Johnson was director of vocational education for the City of Wilmington, Delaware, and in charge of the work for the entire state. Now he is supervisor of teacher training conducted in Oakland under the joint direction of the State Board of Education and the University of California. The classes are conducted in the evening and are for men employed in the trades who desire to enter the teaching field. Most of the men who enter these classes have had over ten years of practical experience in the trade or trades each is looking to teach. There is no educational qualification for admission other than that of satisfying the supervisor as to ability to speak and write English correctly. The course is divided into two major groups, "practical work" and "class work." The former embraces observation of trade classes in operation and practice teaching. The latter includes lectures and discussion of various phases of the theory and practice of vocational education.

LITTLE GIANT MANUAL TRAINING DEPARTMENT Special Equipment

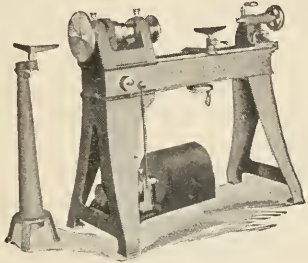

LITTLE GIANT WOOD LATHES

Individual Motor Driven, or Belt Driven from above or beneath.

Furnished with either Bench or Floor Legs. Wide choice of optional tools and equipment. Four speeds.

Many new, exclusive and practical features. All bearings are Hyatt High Duty Roller Bearings which greatly reduce power required. Ball Thrust bearings at all points of end thrust.

Sold on 30 days trial, and **GUARANTEED FOREVER** against defective material and workmanship.

LITTLE GIANT METAL LATHES

Individual Motor Driven, or Belt Driven from above or beneath.

Furnished with either Bench or Floor Legs. Wide choice of optional equipment. Three speeds.

Many new, exclusive and practical features are also found on our metal lathes. They are fitted to receive attachments for grinding, milling, gear cutting, etc., all of which we will furnish at a small fraction of the cost of a separate machine for such work.

Sold on 30 days trial and **GUARANTEED FOREVER** against defective material and workmanship.

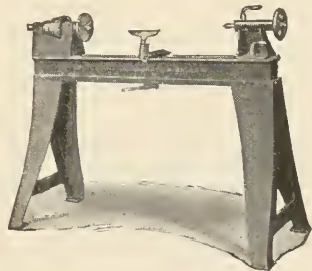

LITTLE GIANT POWER HAMMERS

Individual Motor Driven, or Belt Driven from above. Hundreds of different form-forging dies for instruction purposes.

Standard equipment with leading Technical and Manual Training Institutions.

Sold on 30 days trial, and **GUARANTEED FOREVER** against defective material and workmanship.

DO NOT OVERLOOK

Metal Working Equipment in your school. Wood can never be made anything else, while metal working and alloying are in their infancy.

The Industrial Leaders of the world, to a very large extent, began as metal workers.

Wood working is artistic, and trains mind, eye and hand to deftness. Metal working does all this, and more. It is also practical, and the graduate invariably finds a position waiting for him, while the wood working department graduate usually takes up something else and his instruction is forgotten.



Little Giant Equipment for Technical and Manual Training Schools consists of a full line of all metal and wood working machinery including accessories and tools for same.

On Motor Driven Equipment, information will be required as to Current, Voltage, Phase and Cycles of Motor.

Our business commenced in January, 1876, more than 45 years ago, and our Little Giant Products are used throughout the world. We are anxious to serve you for we can do it well.

Quotations and descriptive literature can be secured from any jobber, or direct from us.



LITTLE GIANT COMPANY

220 ROCK ST.

MANKATO, MINN., U. S. A.



FIELD NOTES—(Continued)

The entire course of teacher training is covered in 288 hours. One half of the time is devoted to the "practical work" and the other half to the "class work." The one hundred forty-four hours assigned to the class work are employed mainly in lectures and discussions, including trade analysis, methods of teaching, organization of teaching material, and instructional management. This year Mr. Johnson is laying most stress upon trade analysis.

—CHARLES L. JACOBS.

IN BOSTON

THE Vocational Education Society of Boston held its usual annual dinner on Saturday, December 17th., 1921, at Hotel Bellevue. President George F. Hatch was toastmaster and he took occasion to outline the aims, purposes and future possibilities of the Society, and further expressed the hope that the splendid spirit of progress and accomplishment which have been manifested will result in placing the Society in a position of national prominence among its kind.

An excellent musical program was provided which included 'Cello solos by Charles Tierney, and songs by Charles Doherty and Charles Tierney, assisted by Mr. Logan, pianist.

John C. Brodhead, assistant superintendent of schools, Boston, who was the first president of the Society, when it was known as The Boston Manual Training Club, carried the members back in a reminiscent way to the first year of the club—twenty-one years ago—when there were but seven members, and traced its steady progress thru various vicissitudes to its present prominent position, with a membership of over 350 instructors and directors of vocational education, many of whom have achieved considerable prominence in their profession and who were also very active in behalf of their country's interests during the Great War. The same loyalty which led these men to volunteer in their country's service has characterized the efforts of the pioneers of the Society to pilot it to its present worthy position.

James Phinney Munroe, ex-chairman of the Federal Board for Vocational Education, spoke on "Reminiscences from the Field of the Vocational Board" at Washington. Mr. Munroe is peculiarly well fitted for those duties which fell to him by virtue of his past experiences, and this fact was thoroly demonstrated during the war period. Two of the most tremendous problems of the Vocational Board were, first, to organize technicians and mechanics for the most effective work during the war period, and

second, to provide for adequate re-hospitalization and re-habilitation facilities for disabled soldiers and sailors. Mr. Munroe is opposed to the idea of carrying on this re-habilitation work in army cantonments, as he believes that the established schools and colleges of the United States are better able to direct, effectively train and re-educate the disabled men than would be any similar group of educational agents in the cantonments, where the problem has been of such comparatively short duration as to afford a very insufficient basis on which to work out an adequate educational system. The policy of the Federal Board has been and is a sincere desire to co-operate as effectively as possible with the individual states, and to assist in carrying out the problems arising in the various sections and communities. Mr. Munroe approves of the idea of a centralized supervision of education in Washington but ventured the suggestion that it might prove more desirable to have a representative board assembled from various sections of the country, to be appointed for varying lengths of service, in order that at no time should the Board be without the services and counsel of some members who were familiar with its problems. Mr. Munroe has always evidenced a kindly interest in the welfare and progress of this Society and was much gratified at the enthusiasm shown by the members.

Mr. C. Howard Walker, a Boston architect and designer of note, spoke about "Industrial Arts," tracing the reconstruction process of industrial art from its chaotic condition in 1860 thru its revival in the Chicago Exposition of 1893 to its present status. Mr. Walker's special plea was that instructors should instill in the minds of their pupils the principle of faithful service and the joy of accomplishment, to the end that we might assist in the development of a generation of artisans who, thru love of creating beautiful and artistic objects would improve the artistic standards of the country.

This meeting was undoubtedly one of the most enthusiastic that has been enjoyed by the members thus far.

—FRANCIS L. BAIN.

SOUTHEASTERN ITEMS

IT has been quite difficult to meet the vocational training problem for the small cities of the South. Many of the places have less than 40,000 people; the industries are varied and the employes are, to a large extent, operators of automatic or semi-automatic machines rather than broadly trained mechanics. The tobacco factories, spinning,

YOUR NEXT BAND SAW

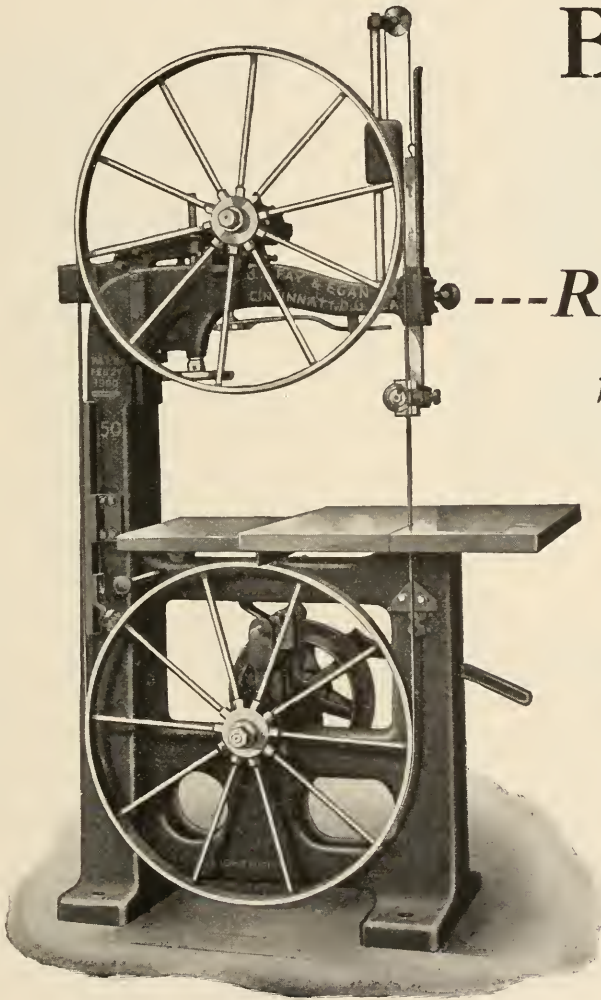

---Reliable

for the student

No. 50 "LIGHTNING"
special patented
Band Saw

The
"Lightning" Line
TRADE MARK REG.
J. A. Fay & Egan

*Write for Special Bulletin M-4 for further details
about this wonderful machine.*

J. A. FAY & EGAN COMPANY

ESTABLISHED 1830

World's Oldest and Largest Manufacturers
of Woodworking Machinery

730-750 W. Front St.

CINCINNATI, OHIO

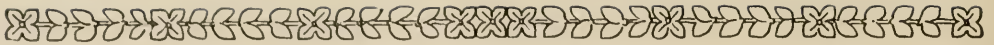

FIELD NOTES—(Continued)

weaving, and knitting mills are good examples of such industries.

Several years ago Durham, N. C., provided a class for boys who were unable to attend all or part of the regular high school classes. The course in general is outlined as given below; but any adjustment can be made to fit the individual and the condition.

"The co-operative industrial course is planned for boys who must work part time in order to stay in school and for boys who wish to learn a trade while attending school. The boys attend school part of the day and work in some industrial plant in the city, or they attend school two weeks and work in the shops of the city two weeks each month. The class work is for the most part of an individual nature."

CO-OPERATIVE INDUSTRIAL COURSE

First year

SUBJECTS	PDS. PER WK.
English.....	5
Math.....	5
General Science.....	5
Woodwork, Drawing.....	10

Second year

English.....	5
Math.....	5
Commercial Geography.....	5
Cabinet Making, Drawing or Printing.....	10

Third year

English.....	5
Math. (Algebra).....	5
Civics.....	5
Metalwork, Pattern Making, Drawing and Shop Math. or Printing.....	10

Fourth year

English.....	5
Math. (Algebra and Geom.).....	5
American History (Especially emphasis on social and industrial problems).....	5
Advanced shop work selected to meet the individual needs of the pupil.....	10

Where conditions permit, the boys are enrolled in the regular high school classes. This plan provides a larger field for association with other students; and after several years of operation the worth of the plan has been well demonstrated.

HARRY K. MOORE is teaching woodwork and drawing at Charlotte, N. C. Each student devotes eighty minutes a day for four days per week during a semester to shopwork. The shop is well provided with power machinery and hand tools. Mr. Moore is an Indiana man and a graduate of the four-year course at Miami University.

ASHVILLE, the city in "the land of the sky" is pushing the industrial work forward in the schools. Edward N. Howell, director, is organizing the work just as fast as space and equipment will permit. The work of the sixth and seventh grades so far has consisted of toy-making and some elementary sawing and planing. Bird houses will be constructed during the spring months.

In the high school, woodwork, turning, and mechanical drawing are offered. Other courses will be introduced just as soon as space and equipment can be secured.

Four instructors are on the teaching staff. G. C. Wible and H. H. Abboll are from the Normal School, Terra Haute, Ind., H. O. Clodfelter from State College, Raleigh, and Orr Glen of Asheville.

—FOREST T. SELBY.

FROM THE SOUTHWEST

MANUAL ARTS IN THE TEXAS NORMAL SCHOOLS

THE rapid development of the system of state normal colleges in Texas within the past ten years has provided an opportunity for special work along manual arts lines within the state. Of the six normal colleges in Texas, five are senior colleges which offer standard college courses leading to a degree.

All of the normals have manual arts equipment suitable to the field which is being served and several have special buildings in which this type of work is carried out. There is a fair degree of uniformity in the equipment for carpentry, benchwork, cabinet-making, and mechanical drawing. Courses in the history, organization, and administration of the manual arts are also offered thruout the system. Additional subject, however, vary somewhat according to locality, the following being represented: concrete work, forging, foundry, machine shop, automobile work, pattern-making and wood-turning.

All freshmen students are required to begin to major in the subject of their choice. If this should be manual arts there is the possibility of two courses in this department with English and education required and an additional elective advised by the department. Under the new certificate law a student majoring for two years in manual arts is eligible for a temporary, special certificate, valid for three years. At the end of the third college year, a four year certificate will be issued; and at the end of the college course a life certificate will be issued.

Each of the state normals maintains a training

New Tools You Should Know

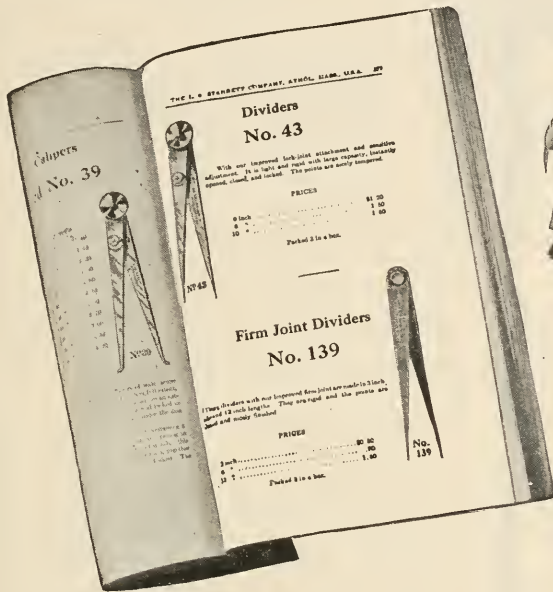

FIRM JOINT DIVIDERS No. 139

A new line of high grade Starrett dividers selling at a moderate price. These dividers are fitted with an improved firm joint and will be found very rigid. The points are hardened and the dividers are well finished throughout. Described and illustrated on page 277 of the new Starrett Catalog No. 22 "EF". Copy of this catalog sent free on request, also special Supplement showing new Starrett Tools.

THE L. S. STARRETT COMPANY

The World's Greatest Toolmakers
 Manufacturers of Hack Saws Unexcelled
 ATHOL, MASS.



Sell Starrett Tools

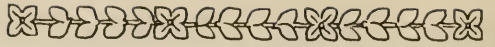

FIELD NOTES—(Continued)

school which reaches from the kindergarten to the normal school. It is here that the manual arts students receive their practice teaching, a subject required of all applicants for a certificate. Since the new certificate does not become finally effective until 1925, the problem of the normal school now is to hold the manual arts students until they have fully equipped themselves for their work. All too often does the student find himself able to locate a "good job" at the end of the first year of college work, or with a few "summers." This has resulted in a proportional lowering of standards in the manual training departments of the public schools. Some steps are being taken to make the school superintendent realize the situation and assist in raising teaching standards until the certificate law becomes effective.

NEW DEPARTMENT AT JOHN TARLETON COLLEGE

The class in trade carpentry, co-operating with the Smith-Hughes law, at John Tarleton Agricultural college, Stephenville, Texas, has just completed a shop 36 x 60 to be used in teaching auto-mechanics and blacksmithing courses. These courses will start with the beginning of the winter term in January. The carpentry class will start a new project at the same time. This new project will be the building of a modern five room house for the Federal Army Officer stationed at the college for the purpose of training the Reserve Officers Training Corps.

—E. A. FUNKHOUSER.

NEW YORK SCHOOL CRAFTS CLUB

THE December meeting of the School Crafts Club was held at the Ethical Culture School, New York City, Saturday Evening December 17.

Charles R. Bostwick, of Poppenhusen Institute, Long Island City, New York, gave an illustrated talk on Industrial and Allied Arts in the Hawaiian Islands. Mr. Bostwick spent three years in school work on the Islands and gave a most instructive talk on a subject of general interest at the present time when the affairs of the Pacific are demanding our attention so generally.

Two Round Table discussions followed the talk given by Mr. Bostwick. "Mechanical Aids in the Teaching of Shopwork" was the subject of discussion at the table lead by Roscoe V. Wolfe of the New York City Schools. Mr. Wolfe had a large collection of charts and other material which he had prepared as aids in teaching. He made a genuine contribution to education. Means should be provided for his passing this contribution on to

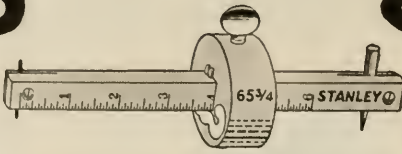

STANLEY

Marking Gauges

In the educational field, Stanley Tools are pre-eminent because of their accuracy, workability and length of service.

Stanley Marking Gauge No. 65- $\frac{3}{4}$ (shown above) is of polished beech, with brass screw, adjustable point and pencil, and face plate. Weight $\frac{1}{2}$ dozen, $1\frac{7}{8}$ lbs.

Bars are oval in form and graduated in 16th of inches for 6 inches from the point, and protected by brass shoe. Face plates are brass, inserted in head to prevent wear.

This is a popular gauge and should be in your equipment.

*Hardware Dealers Sell
Stanley Tools.*

Write for No. 34 Catalog.



The Stanley Rule & Level Plant
THE STANLEY WORKS
NEW BRITAIN, CONN.

*Manufacturers of Wrought Hardware
and Carpenters' Tools*

ENGINE LATHES

BUILT ESPECIALLY
FOR SCHOOL SHOPS

10" to 36" Swing.
Complete with all modern
Features and Equipments.

Widely used in
Vocational Schools.

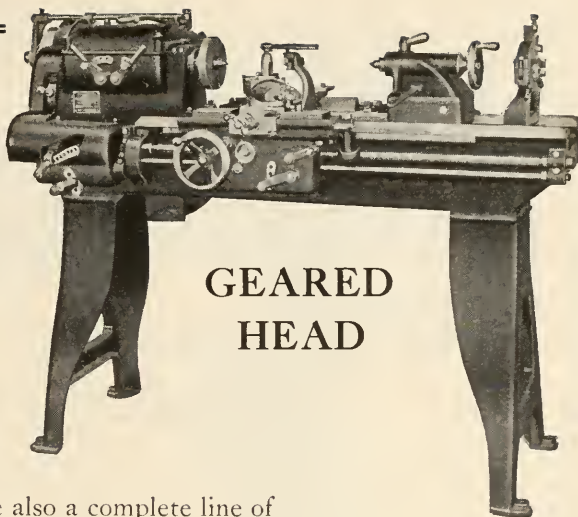

GEARED
HEAD

We manufacture also a complete line of
WOODWORKING MACHINERY
Including the "FAMOUS 30" UNIVERSAL WOODWORKER

Write for Interesting Descriptive Matter

THE SIDNEY MACHINE TOOL CO., SIDNEY, OHIO

Buffalo Combination Woodworker

Twelve
machines
in one

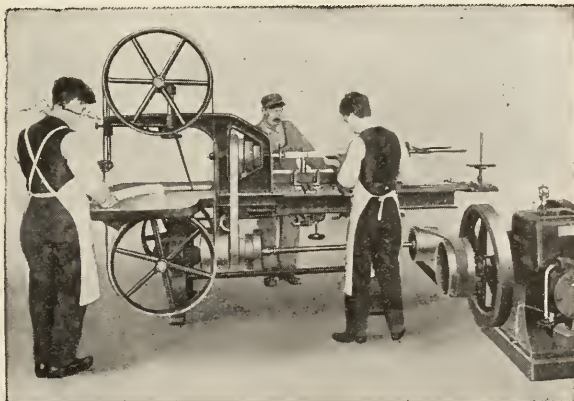

Three
men
can work
at one
time
without
inter-
ference.

With this machine it is possible to give a complete training in woodworking
without an elaborate machine equipment.

Bulletin 360 will show how a small appropriation
can be made to work wonders.

BUFFALO FORGE COMPANY
BUFFALO, NEW YORK

SIMONDS HAND SAWS



Directors of Manual Training and Vocational Schools appreciate that pupils who are started right with good equipment . . . especially saws . . . advance more rapidly. A good saw that cuts easy and holds its edge is a joy to a boy who likes to make things.

Equip with Simonds, the saws of highest quality, and you get the satisfaction you desire in that line.

Write for catalog and prices

**Simonds
Manufacturing Co.**

"The Saw Makers"

Fitchburg, Mass.

Chicago, Ill.

Established 1832



FIELD NOTES—(Continued)

many more. It is evident that his charts and mechanical devices are the results of years of experimental work. His charts on the warping of lumber show mechanically the actual warping of the lumber in such an ingenious fashion as to delight the boy and drive the lesson home.

The Forum was in charge of Allen D. Backus and had for its topic of discussion, "Mechanical Drawing in the Grammar Grades." An interesting discussion followed a proposed course of study for the four Grammar grades. Sentiment as to what the aims of mechanical drawing in the grades should be was somewhat divided as was also the sentiment toward formal problems as a means of instruction. The time for discussion was limited and it would be impossible to state that any definite conclusions were drawn.

This year is the 20th anniversary of the founding of the Club and plans are being made for a dinner celebration at which former presidents and charter members will be honored.

The club is facing a year of promise. Twelve men were proposed and accepted for membership at the December meeting. Industrial arts men in the metropolitan district who are not allied with the club are losing a splendid opportunity.

EDUCATIONAL ASSOCIATION OF WESTERN PENNSYLVANIA

The fall meetings of the Educational Association of Western Pennsylvania were held at the Syria Mosque and Schenley High School in Pittsburgh, Pa., on Friday, November 25, and Saturday, November 26, respectively.

At the Saturday morning session three very inspiring papers were presented to the Industrial Arts Section. These were "Essentials of Furniture Design" by Vincent P. Sollom, assistant professor of industrial arts, Carnegie Institute of Technology; "The Job Analysis" by G. G. Weaver, Department of Vocational Teacher Training, University of Pittsburgh; "State Program in Industrial Education" by G. D. Whitney, Supervisor of Industrial Education, Department of Public Instruction, Harrisburgh, Pennsylvania.

Chairman Joseph B. Ellis, Carnegie Institute of Technology and Secretary J. Lloyd Taylor, Teacher Training School of the Pittsburgh Public Schools were responsible for this rich program. The discussions were full of interest but short as the time was limited.

The officers for the ensuing year are:

Chairman, Rodney Brace, Principal Schwab Industrial School, Homestead, Pa.

"STAR" LATHES

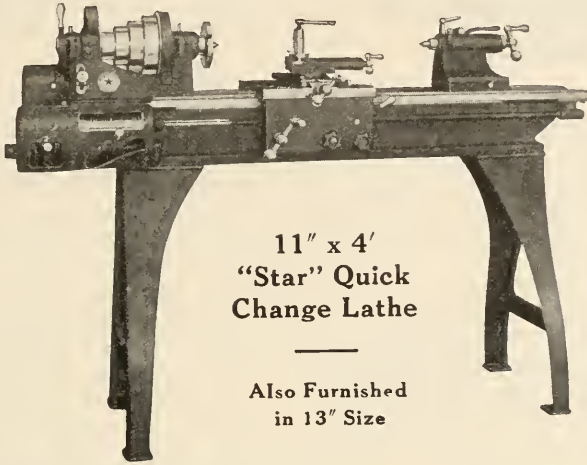

11" x 4'
"Star" Quick
Change Lathe

Also Furnished
in 13" Size

The Last Word in Quality, Efficiency, Service

THE SENECA FALLS MFG. CO., Inc.
SENECA FALLS, N. Y.

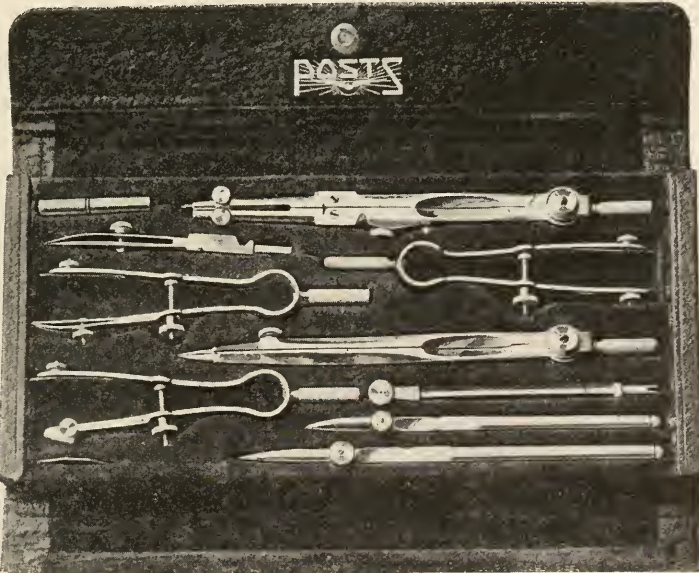

Special Offer Unusual Bargain

No. 1070C Set in Case Ruling Pen Compass, \$2.40.

No. 1071½C Set in Case Ruling Pen, Bow Pen, Hair-spring Divider Compass, \$3.00.

No. 1073C Set in Case Ruling Pen, Bow Pencil, Bow Pen, Hair-spring Divider Compass, \$3.30.

No. 1075C Set in Case Ruling Pen, 4½", Ruling Pen 5½", Bow Divider, Bow Pencil, Bow Pen, Hair-spring Divider Compass, \$3.90.

POST PAID

LIMITED QUANTITY FOR IMMEDIATE ORDER ONLY

THE FREDERICK POST CO.

Salesrooms

319 S. Wabash Avenue.

CHICAGO

Main Office and Factory

3635 No. Hamlin Ave., P. O. Box 803

Wiley Books

For Agricultural Draftsmen

Ready February 10th

FARM BUILDINGS

By W. A. FOSTER, Farm Building Specialist, Iowa Agricultural Experiment Station, and DEANE G. CARTER, formerly North Carolina State College of A. and M. Arts.

A WILEY AGRICULTURAL ENGINEERING SERIES BOOK,

Prof. J. BROWNLEE DAVIDSON, Editor

Teaches how to plan and construct the proper kinds of farmhouses and the barns and other buildings that are incidental to every well-equipped farm. Cost estimating is also taken up.

377 pages. 5 3/8 x 8 1/8. 331 Figures.

ARITHMETIC FOR CARPENTERS AND BUILDERS

By R. BURDETTE DALE, M. E., formerly Department of Engineering Extension, Iowa State College.

For the beginner and student, as well as for the carpenter and builder.

231 pages. 5 by 7. 109 Figures. \$1.75.

DRAWING FOR BUILDERS

By R. BURDETTE DALE, M. E.

Especially useful to the practical builder and to those wishing to become architects' draftsmen.

166 pages. 8 by 10 3/4. 69 Figures. \$2.50.

AGRICULTURAL DRAFTING

By CHARLES B. HOWE, M. E.

Gives a knowledge of the principles of agricultural drawing and their practical applications.

63 pages. 10 3/4 by 8. 45 Figures.

26 plates. Cloth, \$2.00.

Send for copies on Free Examination.

WILEY FREE EXAMINATION COUPON

John Wiley & Sons, Inc.,
432 Fourth Avenue, New York City.

You may send me the following on 10 days' approval:

I agree to pay for the books or return them within 10 days of receipt.

.....
.....

Name

Address

If teacher, state school.....

If not teacher, give reference.....

M. T. M. 2-22

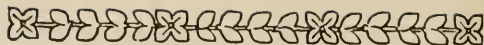

FIELD NOTES—(Continued)

Secretary, James R. Glenn, Supervisor of Industrial Education in the Pittsburgh High Schools.

—ALLEN D. BACKUS.

MECHANIC ARTS TEACHERS IN SESSION

THE Philadelphia Mechanic Arts Teachers' Association, which consists of high-school instructors, holds four meetings each school year. The second meeting for this year was held December 16. The President, Chas. F. Bauder, head of the department of mechanic arts, Central High School, introduced Dr. Harry F. Keller, Principal of the Germantown High School, and William F. Gray, Principal of the William Penn High School for Girls, who made addresses.

Dr. Keller discussed the relation of mechanic arts courses to college work. He stated that under a system of promotion by subjects the mechanic arts students was at a disadvantage, owing to the fact that under this system there are only twenty-five hours available for classroom work, and mechanic arts work, being in the nature of laboratory work, counts for less credits. The difficulty was being met by a system of elective courses for mechanic arts students. For boys to choose between those subjects which make for college and those which do not is difficult, for most boys do not know that they want to go to college until the last minute. Colleges must be made to understand that mechanic arts courses are just as important as any other.

Mr. Gray pointed out the difficulty of co-ordinating the work of his school (vocational) with college work. Many girls directed by friends find themselves in wrong channels. Perhaps the new intelligence tests may solve the difficulty by testing mental capacity. It was found that the graduates of the old three year course in the Central Manual Training School held their own in college in competition with students from regular four year high school courses.

Concluding remarks were made by Geo. T. Astley of the West Philadelphia High School who pointed out that the tendency in mechanic arts today is back to the ideals of thirty-five years ago when accuracy in form and finish was stressed.

—EDWARD A. HUNTINGTON.

TOOLS

For Manual Training Shops.
Send your inquiries to and get the especially low prices quoted by

MONTGOMERY & CO. Inc.,
105 Fulton Street New York City

Manual Training Magazine

FEBRUARY, 1922

SELECTION AND TRAINING OF INSTRUCTORS FOR VOCATIONAL SCHOOLS AND SHOPS

BEVERLY B. BURLING

Head of Electrical Department, Boy's Technical High School, Milwaukee, Wis.

ANYONE who is familiar with vocational school and shop conditions will admit that there is a pressing need for men capable of giving proper instruction. Every shop foreman will emphasize the statement that one of his greatest problems is the "breaking in" of inexperienced help. This situation created the necessity for an organization which would be inconvenienced the least during changes in the working force. Jobs were subdivided into operations and automatic machines were constructed to increase the production and efficiency of the shop. In spite of all this development there is the "breaking in" period. In fact, there are few operations or jobs which cannot be done better after acquiring experience or receiving instruction. Instruction whether given in the shop or school is absolutely necessary.

The kind of instruction given is largely determined by the kind of instructors employed just as a tool, if it is the product of individual effort, receives the imprint of the maker. Should the selection of instructors be upon the basis of academic or shop training? It would be almost a panacea if the choice could always be made from a group of individuals who have had both. Inasmuch as this condition does not exist is it better to develop instructors from skilled mechanics or from academically trained men? It is not expected industrially that one person should presume to undertake the instructional work for an entire

shop, because of the various trades involved, and still it has not been an uncommon practice in some of our schools to expect adequate training to be given in several lines by one individual. This has not been so noticeable in the trade as in the continuation, prevocational, and technical high schools. If an instructor does his work well in one line it would injure him in his effectiveness and weaken the system to ask him to teach several trades. He should always be able to take the working tools and show the learner each individual step. To watch a skilled workman at his trade inspires confidence, because of the ease and grace with which the task is done. It does not always occur to us that it required days and months of persistent effort to acquire the speed and dexterity witnessed in the mechanic. It naturally requires one who is familiar with the job to know the different points and "tricks of the trade" which are necessary in order to become "skilled." This very situation makes it almost a necessity that the instructor be a tradesman of several years experience.

Scholastic training does not have to be a pre-requisite, altho provision should be made in our school systems to permit of self improvement along the academic lines helpful to the work. In this new field the mechanic will find that his attention is changed from production to perfection and his duty now is to see how well others can be trained to do the

job he used to do. Some of the smaller manufacturing companies have fallen into the probably necessary error of expecting one individual to act as production foreman and instructor. The result is evident. Quality is bound to decline with an over pressure on production unless the inspection department is divorced from the production.

Many other qualifications might be considered in addition to personal experience, patience, and adaptability, but under the present consideration the topic will only be expanded to include these all important characteristics. Personal knowledge will testify that it is only with the exercise of great patience that a workman (American, negro, or foreigner) can be instructed in correct trade processes. Adaptability is likewise significant inasmuch as every learner requires a different handling, because of temperament and native ability. A workman who lacks adaptability cannot adjust himself to the job of imparting knowledge and will never make a very successful instructor. Evidence is on every hand, not only in our shops and vocational schools, but in our universities that an individual might be the best workman, scientist or scholar, and, at the same time, the poorest instructor. Skilled workmen between the ages of thirty and forty prove to be the best material to draw from, largely because young men are more adaptable and can cultivate patience better than men of maturer years.

In the learning of any trade there are many different jobs to be mastered and it is the duty of the instructor to first study each individual step or, as we say, "make a time study" of the job. It will enable him to properly coach the pupil thru each operation. It will give him an opportunity to schedule his jobs in the order of their difficultness which is generally in accordance with the number

of motions or operations involved. This method has been used with remarkable success by the writer in industrial and school shops. It is just as fundamental as when applied in determining the relative difficulty of questions. In selecting test exercises or problems their difficulty can always be measured by the number of steps between the question and the answer. As a preliminary basis of analysis there is none better, altho a slight rearrangement of sequence may be found advantageous because of duplication of operations. This job analysis is further evidence that a trade instructor should be a trade man with additional qualifications of adaptability, patience, and personality and sufficient scholastic training to "put the job across."

Having determined the proper sequence of jobs in each "block" the next operation is to determine the proper sequence of "blocks." In other words the next operation is the assembling of the "blocks" designed to make up the completed structure of a skilled tradesman. To a tradesman this step is easy for he knows from experience that fixtures are not hung until after the house is wired or the house is not shingled until after certain other operations. To reverse the order of the proper block sequence would be to invite criticism from industry. This criticism, heard frequently where the exercise methods are used, is "your men may know each operation but they are lost when sent out on a job."

Proper instruction can only be given after the following questions are studied and answered in the light of industrial practice, experience, and judgment:

1st. What is to be taught?

2nd. When is it to be given and in what order?

3rd. How is it to be presented?

Much that has been said has been in answer to the first two questions. The

"How is it to be presented?" will involve further thoughtful consideration. Instruction consists not only in the telling or showing a learner how an operation is done. Coincidentally with the telling or showing there must be a process of reasoning aroused which will "tie up" the act with some mental effort on the part of the learner. If we were training machines, mind processes would not be necessary but here there must be cultivated intelligent thinking if we are to expect intelligent acting.

It will be evident to any one who gives this subject much thought that proper instructions, as indicated above, will greatly reduce the drill or repetition so often resorted to. Drill, in manual processes, trains for muscular dexterity rather than a knowing, thinking workman. Speed can be developed quickly after the operations are thoroly understood.

In many shops statements are heard which indicate poor methods of instruction. For example:

1. "Turn that hack-saw around."
2. "Take hold of the hammer near the end."
3. "That rivet is not hot."

How much more instructive it would be to change the commands to questions like the following:

- 1a. "How do you hold the saw in order to make the teeth cut?"
- 2a. "Don't you think you could get greater force with less effort if you took hold of the hammer near the end?"
- 3a. "How do you know when the rivet is hot enough?"

Questions 1a and 3a are development questions requiring mental effort in the response. Question 2a is purely informational, yet how far superior to "Take hold of the hammer near the end?" Many questions like these can be used to awaken a mental response from the

learner. The habit should be cultivated in all teaching whether vocational or academic, to draw out the pupil by "question method." This unfolding of the mind of the learner will mean probably more toward his success than the actual knowledge of trade processes.

Many an instructor will find himself falling into the error of doing things for the pupil. Sometimes this is because of impatience, or because a supervisor is too exacting, expecting to see perfection in the student's work. Possibly the instructor "wants to make a good impression" or per chance he lacks the knowledge of proper instructional methods. The duty of a teacher should always be to the pupil. His job is the turning out of skilled intelligent workmen, not furniture or objects of iron or stone.

The efficiency of an instructor in a commercial shop, and in an educational institute is determined by two quantities:

1st. The character of the output in skilled workmen.

2nd. The student or labor turnover. The first determines the success of the instructor in teaching or more specifically in "putting an idea across." The second indicates temper and patience, and, in a commercial shop is quite as important as the first. Turnover of student labor indicates "scrap material" discarded during the process of instruction. This material has been of little value but of considerable expense.

In the elimination of scrap the "rough stock" is inspected to determine its suitability before it is turned over to an expert workman. This inspection and elimination, before much actual work has been done, greatly increases the efficiency of any organization. The instructor, altho not always responsible for the material given him, may aid materially in redirecting the same into channels more

fitting. It is in this connection that a teacher should determine soon after a learner comes under his supervision whether or not the material appears suitable for the job. An individual who is nervously constituted and cannot do work on a ladder would not qualify as an outside wireman, any more than one who is color blind would be fitted for a locomotive fireman or engineer. Such information regarding employees or students should be available to the instructor who can obtain data therefrom for his special work.

A 5" x 8" card, like the one shown below, on which is recorded the data has proved adequate for the average shop or school.

In conclusion: An instructor who has been selected because of his ability as a skilled workman and who has made a detailed study of his trade should qualify himself still further by developing the ability to analyze and understand the material with which he has to deal. Further, to handle the same in such a manner that will awaken and unfold the individual. To this end provisions should be made, in schools and shops, for suitable talks or courses of instruction for instructors and foremen to be given by men who have proven themselves in industry *and* education. This will materially aid in developing a corps of instructors of whom any institution would be proud.

RECORD CARD

Name _____ Age _____ Phone _____

Address _____

Father's name _____

Address _____

Occupation _____

Parent's signature (if possible) _____

Schools attended _____

Reasons for leaving _____ Date _____

Future plans _____

Observation: Intelligent _____ Alert _____ Slow _____ Neat _____ Mature _____

Attractive _____ Courteous _____ Forceful _____ Self Reliant _____

Physical Defects _____

INDUSTRIAL HISTORY

Firm	Industry	Time Employed	Wage	Reasons for change



FIG. 1. FRONT OF MAIN BUILDING—VOCATIONAL BUILDING SEEN IN THE REAR.

THE OKMULGEE HIGH SCHOOL

CHARLES A. BENNETT

THANKSGIVING week, 1920, I spent in the State of Oklahoma. It was my first visit to that state and for that reason I was perhaps especially sensitive to the educational atmosphere. I was impressed with the fact that I was with a group of men who are looking forward instead of backward. They did not talk much about what they had accomplished, but all the time about what they were going to do. They seemed to take the attitude that all things are possible in Oklahoma. Each man believed in his state, his town, and his school. This spirit was epitomized by the porter on a Frisco train, who called out, "The *Dallas News* and the *Daily Oklahoman*, the best papers from the best towns from the best part of the United States," and he spoke with conviction. He was a good salesman.

One day of that week I spent in Okmulgee. I stopped there to see the industrial work in the high school, and I found myself as much interested in the whole scheme of the school as any part of it. The school system under the superinten-

dency of H. B. Bruner, assisted in the high school by E. S. Briggs, was packed full of modern ideas—not only in the form of theory, but ideas in process of being worked out in practice. The school was clearly a place of joyous activity, of growth, of life. I found, too, a school in which salaries were high enough to attract strong teachers. Impressions gained that day and some data received since that time, form the basis of the present article.

This high school had, at the time of my visit, about 900 pupils. The staff included fifteen teachers of manual arts and vocational subjects and only one teacher of Latin, yet the pupils were as free to elect Latin as any vocational subject, but they were not forced in either direction. The only subjects required of all pupils were English, mathematics, American history and citizenship.

Every student is given careful intelligence tests as well as educational tests, and the results of these are used in ranking. In every grade, children of like ability are in the same class.

The course in the school covered six years—grades seven to twelve, inclusive. It is, therefore, a junior and senior high school combined. All students in the city who have passed their thirteenth birthday are in this school. No children over twelve years of age are found in the ward schools. The school includes, also, vocational courses that are subject to reimbursement under the Smith-Hughes

of these courses is nine weeks in length. Every student is required to take four of these courses each year in addition to required work in English, citizenship and mathematics. The following are offered to 7th grade pupils:

Science—A general introduction to science.

Freehand Drawing and Sketching—Pencil and charcoal drawing, water color, shop sketching.

Carpentry—Building garage, chicken house or other carpentry project.



FIG. 2. FRONT OF VOCATIONAL BUILDING.

Act. It is attempting to catch the pupils while young and then hold them as long as possible, but for students who must or will leave school early, the vocational courses are given in the ninth and tenth years. The school offers every reasonable facility for thoro preparation for college, but it offers equal opportunity to prepare for profitable occupation in industry. It says to its pupils upon entrance, "Make up your mind what you want, and go after it. Decide what you intend to do when high school is finished, and begin to prepare for it." Then it provides opportunity for a pupil to change his mind with as little inconvenience as possible, provided there is any good reason for such change. To help students in the making of wise decisions the school gives what are termed "finding and broadening" courses during the first two years. Each

Sewing—Fundamental principles of sewing, machine practice and care of machines.

Cooking—Elementary instruction in food study and preparation.

Business—An introduction to business and office methods.

Public Speaking—How to appear and express one's self in public.

Journalism.

Automobile Mechanics—Learn to care for a car.

Music—Special work in singing. Open to girls and boys.

Vocational Information.

Eighth grade pupils were offered the following:

Science—A general introduction to technic of science.

Cement and General Repair Work—Concrete and ornamental cement work; all kinds of repair work; locks, utensils, toys, bicycles, etc.

Sewing—Fundamental principles of sewing, machine practice and care of machines.

Cooking—More advanced instruction in food study and preparation.

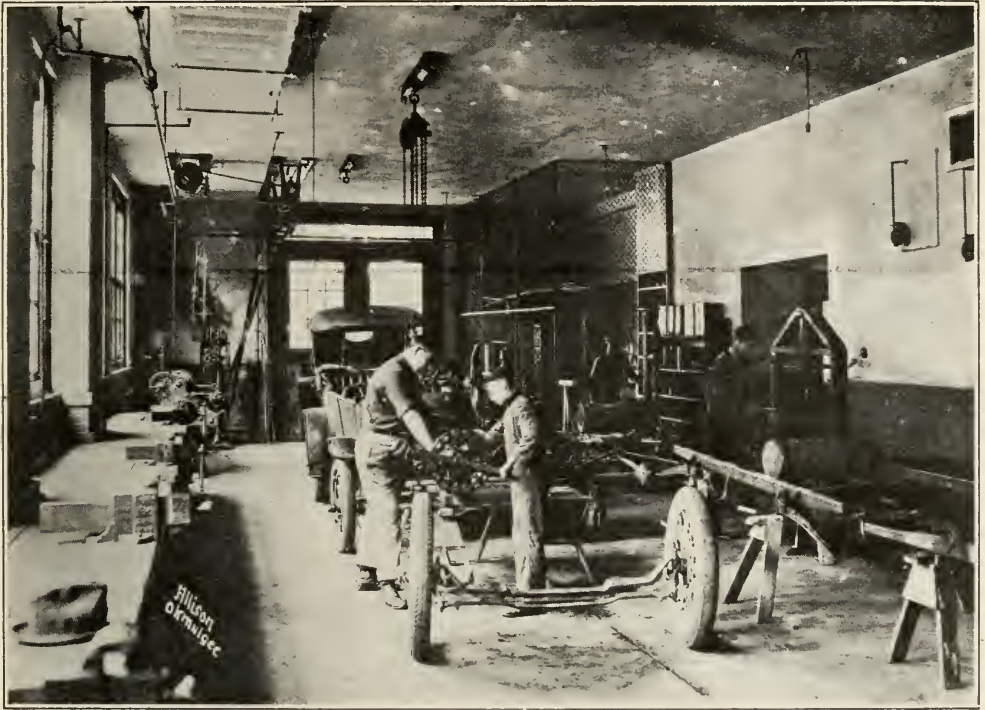

FIG. 3. AUTOMOBILE SHOP.



FIG. 4. ONE END OF GENERAL SHOP.

Business—More advanced instruction in business and office methods.

Electricity—"Do it electrically."

Public Speaking—How to appear and express one's self in public.

Printing—Elementary typography.

Home Nursing.

Art.

Music.

English-Latin.

Vocational Civics.

Vocational Information.

The activities listed for the seventh grade were

Art appreciation,

Literary society,

Nature study,

Picture book club.

For the eighth grade they were

Art appreciation,

Literary society,

Personal hygiene,

"Free hour."

The activities for the remainder of the school were

Short story,

Science

Debate,

Literary society,

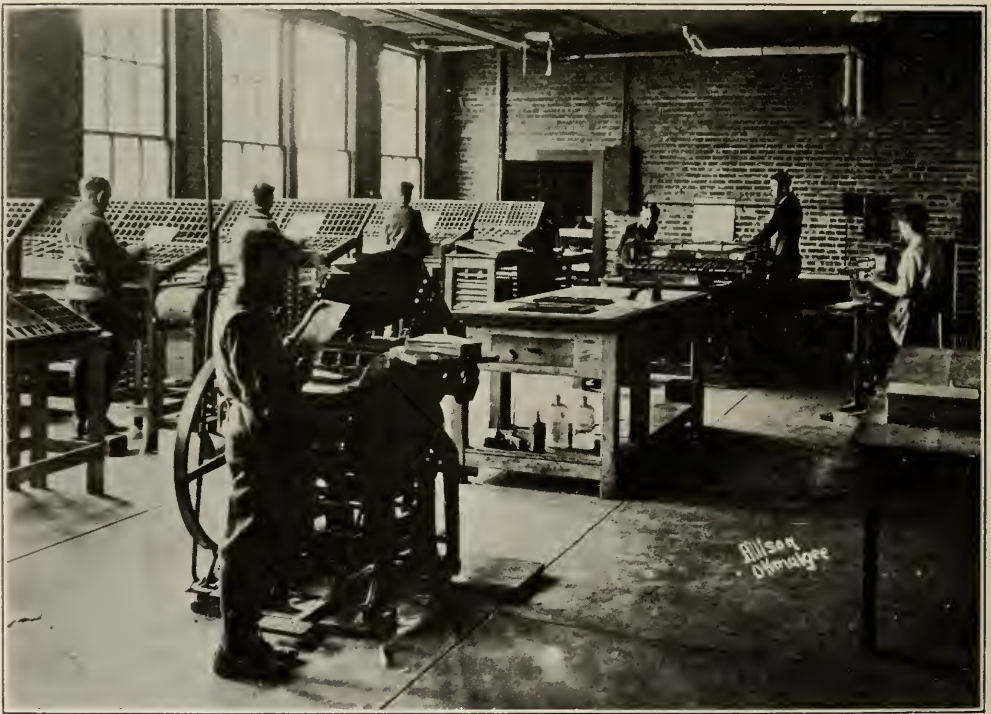

FIG. 5. PRINT SHOP.

Closely connected with these finding and broadening courses in fundamental idea, at least, I found that the free activities of the school-clubs, athletics, societies, etc., had been organized and credit for participation allowed. Twenty-eight units were required for graduation. Of these, twenty-one must be "solid subjects," and the remaining credits might be activities or "finding and broadening" subjects.

Interior decorating,

Folk dancing,

Catering for special occasions,

Library methods,

Banking,

Literary society,

Dramatics,

Visiting club,

Girls' auto driving,

Gym,

Astronomy and math.,

Impromptu,

Spanish club,

Travel club,

Mythology,

Glee club—boys,

"Keeping fit",

Girls' story telling,

Science play,

Shakespeare club

Cartoons,

French club,

Latin club,

Basket ball,

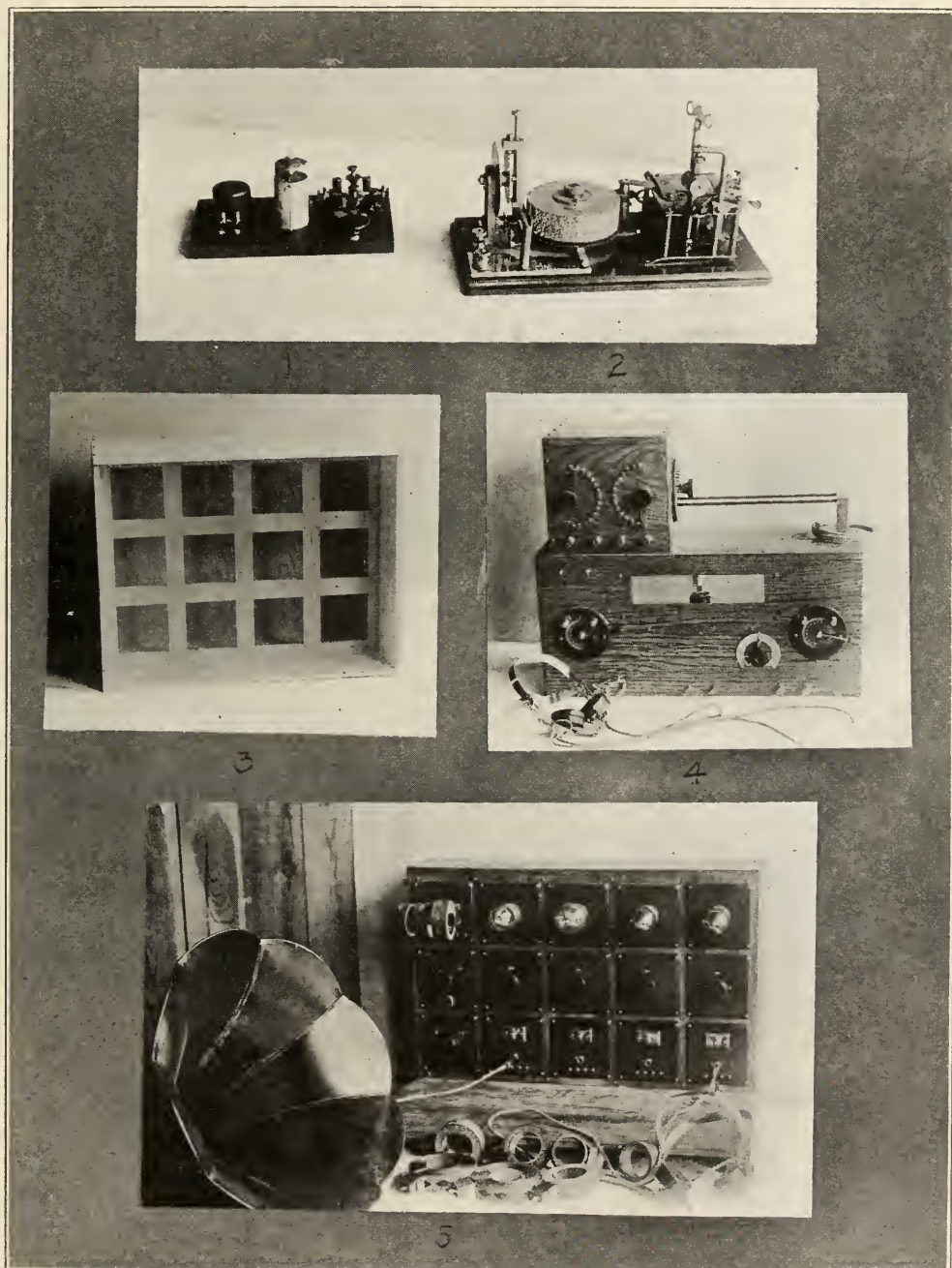

FIG. 6. PROJECTS MADE IN ELECTRICAL SHOP.

Glee Club—girls,
Browning club,

Modern short story,
Landscaping.

The last twelve in the list met twice a week; all the others once a week. Most

of them came into the program of the regular school day, tho a few were after school hours. A student was allowed to take three or even four activities at one

time. Some of the activities were six weeks in length, others nine and still others a half-year or even a whole year. Most students are required to take some activity every day.

Turning now to the manual arts and industrial courses, three types were given; (a) the finding and broadening courses, (b) the courses for students who wished manual arts instruction for one reason or another as a part of their work of the last four years of the high school, and (c) the trade or vocational courses, two years in length, supported, in part, by Federal funds.

There were six courses of the first type, namely, automobile repair, electricity, printing, carpentry, drawing, cement work. An obvious characteristic of these shop courses was that many of the projects were large ones, requiring the co-operation of several students or a whole class, as a play house in carpentry and garden furniture in cement work.

In the list of courses of the second type were (1) for ninth year boys, a general shop course, including wood-finishing and painting for six weeks, chair caning and furniture repair for four weeks, metal repairs, soldering, glazing, etc., for six weeks, pipe fitting and plumbing repairs for three weeks, forging for five weeks and cement work for six weeks; (2) for tenth year boys, a course in wood-turning and

cabinet making; (3) for junior and senior boys, a course in advanced cabinet making and (4) a course in practical drafting; and (5) arts and crafts course for senior girls.

Courses of the third type, that is, unit trade courses, were given in (1) carpentry, (2) electricity, (3) automobile mechanics, and (4) printing.

When I was there the new building for vocational work, Fig. 2, was not quite completed, and the instruction was being given in temporary quarters, but I was impressed with its fine spirit and the high ideals and practical training of the teachers in charge of the work.

As I left Okmulgee, I felt that I had been in a high school which, in larger degree than any other I have ever seen, was applying the best of modern pedagogical ideas with reference to (a) keeping all secondary education a unit in spirit and purpose, yet sufficiently varied in detail to meet the individual needs—mental and temperamental, real and unreal—of all sorts of students, (b) giving the right kind of vocational and educational guidance thru typical experiences, and not merely depending upon information about certain occupations or upon the dictum of any one teacher or school official; and thru it all (c) recognizing the importance of living democracy of the American type while being trained to become American citizens.

I have the conviction, even, that education for a calling offers us the very best foundation for the general education of a man.

—KERSCHENSTEINER.

PAPER DRESS FORM MAKING TAUGHT IN SCHOOL

H. W. ROBERTS

Vocational Director, Anderson, Indiana

THE making of dress forms from gummed paper was introduced in the sewing classes of the vocational course at Anderson, Ind. in the fall of 1920. It proved so popular that it was offered as

for a few days previous to the opening night. Over 200 women enrolled for the work, and as it was necessary to keep the number in a class quite small, they were divided into groups of fifteen in the order



^ DRESS FORMS MADE OF PAPER.

a course in the free evening schools during the winter.

Any woman who does her own sewing appreciates the advantage of a form which is the exact reproduction of herself, and since a commercial product is quite expensive, the paper form seems to meet an urgent need.

The course was advertised in our evening school literature the same as any other course to be offered, but since the idea was new to many, one of the forms made in the day vocational class was exhibited in a downtown department store window

enrolled. The first fifteen were divided into groups of five each. One of each group was chosen to stand for her form, the other four doing the work under the direction and with the help of the teacher. Three forms were made during the evening, thus taking five evenings to complete the unit.

The process is very simple, but in order to complete the work before the person tires of standing the paper should be cut in short pieces before starting. Lengths of 5", 12" and 19" were found to be most convenient. Common 1" gummed tape

such as used in stores for fastening packages was used at first, but the heavier $1\frac{1}{4}$ " tape such as used in paper box factories was found to be much more satisfactory as it worked much faster and made a more durable form.

Four layers are stuck on a "gauze shirt" worn over the corset cover just as one would dress for a fitting. After putting strips of paper (which are drawn tight) under the arms, around the bust and around the hips, you begin to build the form by putting on your first layer with the strips of paper running perpendicular, the second diagonally from left to right, the third diagonally from right to left. Then it is removed by cutting it open in front and back. About $\frac{1}{4}$ inch is cut from each of the four edges to allow for the thickness of the shell, and then the two halves are fastened together by sticking short pieces crosswise inside and out.

In order to determine the exact amount that should be cut out, the person should be measured before and after the paper is applied, and one-fourth of the difference, (which varies) should be cut from each edge.

After going over and sticking down all loose ends it is ready to shellac. Two coats of white shellac will make it rigid and keep the paper clean. Boards cut to fit and tacked inside the neck, arms and bottom will make a much more solid job. The form may now be mounted on a standard or set on a table.

The standards shown in the photograph are adjustable for different skirt lengths. They were made in the shop by our day classes and sold to those who wanted them at cost.

After our night school closed, there were still a number of women who were anxious for the work, so units were formed in different school districts over the city and a teacher sent to them once a week. These units, when thru were formed into sewing clubs by the teacher, and continued thruout the term.

ITEMIZED COST

Gauze shirt.....	50c
Gummed paper.....	50c
Shellac.....	50c
Boards.....	50c
Iron adjustable pedestal.....	\$1.50

OUTSTANDING FEATURES OF NATIONAL SOCIETY CONVENTION

E. E. ERICSON

TO ATTEND a meeting such as the fifteenth annual convention of the National Society for Vocational Education, held in Kansas City, January 5, 6, 7, is indeed a distinctly enjoyable and profitable experience. To sit down, after the convention is over, and attempt to sift out from the sum total of ideas and inspirations received, those which are truly representative of the spirit of the convention as a whole and which will picture the meeting fairly to people who did not attend may be also a profitable task but it is not an easy one. It is more

difficult because it involves the problem of being fair to all who contributed to the program, and particularly to the principles and ideals presented during the course of the convention. No attempt will be made in this brief discussion to go outside of the industrial phases of the convention activities.

As far as its industrial education program was concerned, the convention might well be said to have centered attention largely upon two outstanding problems: (1) the purpose, organization, and administration of the part-time

school, and (2) the proper understanding and co-operation between vocational schools and the employers who are to use the human product turned out by these schools. While other problems, such as the source and training of teachers for full-time and part-time schools, placement of vocational students, the proper use of text-books and other published material, etc. received attention, the discussion of these problems often reverted to one of the general problems mentioned above.

CO-OPERATION BETWEEN SCHOOL AND EMPLOYER

One of the first speeches of the convention, and one which emphasized more strongly perhaps than any other the necessity of co-operation between the schools and the people who are expected to employ students or graduates, was made by L. S. Hawkins, educational director of the United Typothetae of America. In this talk, after giving a brief discussion of the history of the work of the United Typothetae, Mr. Hawkins made the statement that it is the purpose of the Typothetae to use the vocational schools now in existence and those which may come into existence, for the training of printing apprentices, provided these schools will be open to suggestions with regard to courses of study and methods of teaching in order that the pupil who takes training shall be given the type of practice which will be a partial preparation for his trade.

The statement was further made that school officials and teachers need to consider more fully their responsibility as well as their opportunity in this respect. There was no attempt made to place the entire blame for lack of service by the school on the school officials, however. While the average printers' organization would be likely to condemn the

work of the vocational school, it was pointed out that nothing has been offered by them in a constructive way which would tend to improve the work in the school. Mr. Hawkins expressed the belief that more work needs to be done among employers in this respect than among school men, but clearly indicated that much attention must be given to the problem of co-operation and adjustment by both sides. That the vocational school should be so organized that only a small number of its graduates should be sent out into the trade at any one time and that it would suit trade conditions better to have several groups thru the year was another suggestion made.

Another talk which emphasized the necessity of sympathetic understanding on the part of employers as well as labor unions of the work of the vocational school was made by C. A. Prosser, director of Dunwoody Institute. He stressed the necessity of selling the idea of vocational education to the people of the community. He criticized many directors and supervisors for spending their time in menial work around their shops rather than looking after the larger policies for the promotion of the general good of the school. The director must first of all sell himself both to labor and to the manufacturer. He must play fair with all, decide upon an open policy, with all cards on the table, and not allow himself to be persuaded to deviate to one side or the other. Absolute fairness, Mr. Prosser said, will win the respect of all even if all can not be suited.

THE PART-TIME SCHOOL PROGRAM

The problem of the part-time school was approached by different speakers, from two distinct viewpoints. One line of thinking in connection with the part-time school emphasized the vocational opportunities which should be given to

the students who return to the continuation schools. The vocational activities would make the pupils more efficient technically in their particular vocation.

The second type of philosophy underlying the activities of the continuation school was perhaps best represented by Professor Leonard of California who advanced the idea that the function of this type of school is not vocational and not even instructional, but social. Professor Leonard stated that the problem of the continuation school is not primarily a problem of instruction but of a philosophy of life.

In order to establish this social philosophy then, the continuation school must seek to control not only four or eight hours a week of the students' time but the other forty hours also. With this viewpoint in mind concerning the problem, it follows that the teacher of the continuation school must be more than merely a craftsman or a scholar. The efficient teacher must be one of the Boy-Scout type of men who will take an interest in students beyond the limited contact which he has with them in the classroom. For girls, a woman with maturity of experience, and a motherly feeling toward her pupils is the only one who can successfully contribute to the building of a correct social philosophy in the lives of working girls.

Regarding the training of teachers for part-time work and for vocational subjects generally, Professor Leonard suggested that a well-organized program was necessary rather than haphazard, quick-service methods. He said that it is a question of a program rather than a "patent pill." In California a forward looking program covering in scope the coming ten years, is being launched. This program will be given a fair chance

to succeed before it is revised or discontinued.

SELECTING SHOP TEACHERS

The New York plan of selecting shop teachers, presented by R. H. Rodgers, state supervisor of industrial teacher training, is of special interest. In this state, thru a system of testing and grading shop men who wish to go into the teaching business, twenty-five are selected each year for one or two years of residence teacher training. This method promises to put into the field a number of men who have not only the technical information and the skill but also the necessary breadth of outlook upon the social problems of industry to make them most valuable as instructors in their chosen field.

Not all the good things of the convention have been covered in this report. The problems of industrial rehabilitation, job analysis, related subjects, junior employment and counseling, etc. all came in for discussion. My impressions of the most significant of the problems which were of most general interest are those which have been briefly pointed out.

The business session, which was the last on the program, was well attended. The efficient work of the president, L. A. Wilson, state director of vocational education, New York, was heartily endorsed, and Mr. Wilson was re-elected for the coming year. The most important resolutions adopted were: approval of the creation of a Federal Department of Education; an expression of appreciation of the work accomplished by the Federal Board for Vocational Education; and a recommendation that in case the Federal Board is to be dissolved, the work which it is now doing be put in charge of an assistant secretary in the Department of Education.

A CROSS-SECTION OF THE MILWAUKEE CONVENTION

CHARLES A. BENNETT

IF THERE is a standard test by which to determine the efficiency of an educational convention, I have not heard of it. But if there were such a test, and if it were applied to the recent meeting in Milwaukee I am sure the rating would be high. Numerically, financially, socially, inspirationally, instructively, the Milwaukee meeting of the Vocational Education Association of the Middle West was a success. Six hundred and thirty members registered at the meeting and there were some persons present who did not register. When the new members have been added to the roll it is probable that the total number will be about nine hundred. This fact alone demonstrates that the Middle West now has a vigorous young organization that is attractive to teachers and supervisors of vocational subjects. The wisdom of the financial policy of the Association is again demonstrated, not only because it makes possible a low membership fee and ample funds to carry forward the work between conventions, but also because the commercial exhibits, the largest source of income, have, under the efficient supervision of Albert G. Bauersfeld, been a very attractive and instructive feature of each meeting. Another large factor in the success of the recent meeting was the opportunity offered to study Milwaukee's excellent vocational schools. Supervisor Charles F. Perry and Principals Cooley, Cox and Miss Blancher were most gracious hosts.

PSYCHOLOGY APPLIED TO VOCATIONAL EDUCATION

Concerning the program of addresses I think many of the members would agree that its most significant feature had to do with the applications of psychology to the problems of part-time education, and to vocational guidance and placement. In fact, the addresses by Dr. Carl Seashore

of Iowa State University and the vocational guidance programs planned by Professor Harry D. Kitson of Indiana University stand out in my mind as more definitely helpful than anything previously presented in that field, and they were indicative of real progress.

In beginning his address on "Certain Principles of Vocational Advice Based on Nothing but Common Sense," Dr. Seashore said that "what is science today will become common sense tomorrow, provided it is practical." He illustrated this by the evolution of lighting in homes—candle, oil lamp, gas, electricity. He gave emphasis to his point also by calling attention to the changes in the method of lighting a fire and by saying that the man who does not use a match has an extremely low I. Q.

Dr. Seashore spoke of the present as the golden age of applied psychology. The previous evening, at the Bureau of Education conference, after listening to accounts of what is being done in Minneapolis and Detroit to provide proper supervision and guidance for employed boys and girls, he had said that the meeting was a thrilling event for him because he had been dreaming of such things for a long time. What he had listened to was the logical outcome of the psychological movement; it was the result of the discovery of the individual; vocational guidance was but an application of psychology. The industries had discovered the individual, but often the schools had not. Too often the schools had taken the attitude that as God Almighty had failed to make all men equal, it was the business of the public schools to do it. He pointed out that we did not really know the nature and extent of this fallacy until we began to measure capacity. Previously we had been measuring in terms of output which

we have tried to make equal for all, just as the labor unions are trying to do today. Dr. Seashore gave as his creed: *Keep each youth busy at his highest level of achievement, and he will be happy, useful and good.*

Following this creed means a larger educational program than ever before. Individual differences among children must be taken into account more than heretofore. According to the speaker it may be assumed that one person may have twenty times the capacity of another in memory, observation, imagination, reasoning, etc. This enormous magnitude of individual differences can now be measured by scientific means.

Referring directly to vocational guidance, Dr. Seashore said that the best occupation in life is the one which one would choose regardless of income. "The best form of guidance is the motivation of the boys and girls to choose for themselves, after having provided favorable conditions for a choice." And avocational guidance is quite as important as vocational guidance.

In a later address on "Vocational Guidance for Musicians" Dr. Seashore said that definite tests have been worked out by which a student may register his capacity with reference to discrimination in pitch, time and intensity, also in harmony. Phonograph records are used in giving this test. The famous musicians are not all equally proficient with reference to pitch, time and intensity. Some may be considerably deficient in reference to one or more of these and yet, on account of other qualities be good musical performers.

COMMON SENSE IN VOCATIONAL EDUCATION

Two addresses that made a strong appeal to the members of the Association were given at the annual banquet by Alfred Vivian, dean of the College of Agriculture of the Ohio State University,

and E. E. Lewis, superintendent of public schools, Rockford, Illinois. Dean Vivian's address purported to be a personal experience in going back to the home of his boyhood days and observing the changes in life and conditions of living on the old farm. It presented in remarkable contrast the typical farm home of the past and the ideal and possible one of the present day. It was a vision of what may become common in the future.

Superintendent Lewis, in between his stories, said some very sensible things about present conditions, speaking, of course, from the standpoint of a school superintendent. Among these he insisted that spiritual, not economic values are the determining factors in what education shall be given. Toward the end of his address he summarized what he had said in fourteen points. Here are thirteen of them:—

1. Culture must keep a balance between vocational and general education. The vocational educator must support general education as much as vocational education. Let us not fight each other. In unity there is strength.

2. Let us cut out a little of the bluff—get down to facts. There is too much bluff yet about general education.

3. Begin to avoid in vocational education some of the acknowledged defects of general education.

4. Quit scattering. We are trying to do too many forms of work in both vocational and general education. Center effort on fewer things. (I wish he had added, "Go slow. Do not try to do everything the first year.")

5. In vocational education learn more thru the eye and ear and not so much thru the hand.

6. Reduce some of the elaborate equipments. You don't know that you are getting full value from these expensive equipments. Perhaps it would be better to employ superior teachers.

7. There are 17,000 ways of earning a living in the United States. Work a little more scientifically in vocational guidance.

8. We need more economical methods of teaching.

9. We need more co-operation with industry. Go and get it.

10. We need more and better supervision of juvenile labor.

11. We need more and better measured results.
12. We need broader trained teachers.
13. We must become financiers. We should train ourselves in school finance—make budgets.

PREVENT INDUSTRIAL ACCIDENTS

On Saturday morning George Hambrecht, state director of vocational education in Wisconsin gave statistics showing the large number of accidents in the United States and in the state of Wisconsin, calling attention to the necessity of taking action in reference to this matter. Two hundred twenty-two people are killed each day in the United States. Fifty times this number of serious accidents occur. Ten millions of dollars are lost in Wisconsin each year thru industrial accidents. Definite national and state programs need to be developed regarding this. "An ounce of prevention is worth a pound of cure." We should apply more energy at the ounce end instead of trying to work at the pound end. In Wisconsin, three hundred industrially disabled persons have been connected up for re-training. A problem for which the law makes no provision is that of the crippled child. Socially minded persons, Mr. Hambrecht said,

must get together and do something for the children who are started in life against great odds on account of physical disabilities.



The above is but one of many cross-sections of the Milwaukee meeting. Others might be shown if space were available. At the business meeting on the closing day the following officers were elected:

President, William Bachrach, Supervisor of Commercial Education, Public Schools, Chicago, Illinois.

First Vice-President, John N. Greer, Assistant Superintendent of Public Schools, in charge of Vocational Education, Minneapolis, Minnesota.

Second Vice-President, Miss Mary Sweeney, Head of Department of Home Economics, State College of Agriculture, Lansing, Michigan.

Third Vice-President, E. W. Schultz, President of State Board of Vocational Education, Sheboygan, Wisconsin.

Treasurer, James McKinney, Educational Director, American School, Chicago, Illinois.



WIRELESS BOARD—EIGHTH GRADE PROJECT, NEWARK, N. J.

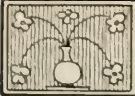

EDITORIAL REVIEW FOR THE MONTH

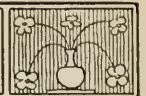

NEW DEVELOPMENT IN DETROIT

EARLY in December I spent a day in Detroit, and felt well repaid for doing so. Professor Emery Filbey of the University of Chicago was there completing his work of organizing a placement and guidance bureau. He was to leave on January 1 to return to his classes in Chicago, and Dr. George E. Myers of the University of Michigan, was to take his place as acting director. Dr. Myers, however, will spend only a fraction of his time in Detroit. The burden of the work will fall upon the three department heads of the bureau. One of these, Peter Cummins, a teacher in the Cass Technical High School, will have charge of the placement work. The second department will gather information—be a research and survey section for the bureau. To head up this department Detroit has secured the services of A. H. Edgerton, who has left an assistant professorship at Indiana University to take this new position. The third department has to do with the issuing of work permits. The new bureau is to occupy the offices in the old building of the Cass Technical High School formerly used by E. G. Allen. The impression I gained from the visit was that Detroit is now laying the foundations for the most practical and effective placement and guidance scheme of any of the larger cities of the country. I shall watch its development with real interest.

THE EQUIPMENT OF INTERMEDIATE SCHOOLS

FROM J. H. Trybom I gathered facts concerning recent developments in connection with the courses offered in the intermediate schools. Detroit now has five intermediate school buildings and

money for four more. Because there has been so much discussion lately on the industrial features of the curriculum and of the shop equipment for this new type of school, I was especially interested in looking over Mr. Trybom's recent report to the superintendent of schools. It seems that three types of buildings have been developed in Detroit for intermediate school work. One provides for 1,800 pupils, a second for 1,500, and a third for 1,200.

The number, size and capacity of the shops in these three types of building are shown in the table on the following page.

The decision in reference to the particular shops to be provided was based on a study of the industries of Detroit. According to figures gathered in 1918, 57,000 men are in the automobile industry in one capacity or another, 16,000 are in the sheet-metal and stamping industry, 10,000 in the forge and foundry industry, 6,000 in copper and brass work, 5,000 in steel products, 4,000 in electrical supplies and electricity, while only 7,000 are in stores, 7,000 in the woodworking industry, etc., thru a long list of smaller items. This makes it clear that Detroit is predominantly a metalworking city, and a further study readily makes evident what are the predominant metalworking processes in Detroit. These figures, in addition to such facts concerning industrial needs as are common to all American cities, have helped to shape the program of studies of the Detroit intermediate schools and consequently the shop equipments for such schools.

In studying the accompanying table, one immediately notices the adoption of the "general shop" idea in one of the six shops. This is for seventh grade pupils.

INTERMEDIATE SCHOOL SHOPS IN DETROIT

	TYPE A-1,800			TYPE B-1,500			TYPE C-1,200		
	No.	Size	Pupils	No.	Size	Pupils	No.	Size	Pupils
General Shop..... Household Mechanics, Sheet-Metal, Electrical, Woodwork, Plumbing, Glazing, Finishing	1	22x50	40	1	22x50	40	1	22x35	24
Wood Shop..... Cabinet making, Wood-turn- ing, Pattern making.	1	22x52	24	1	22x52	24	1	22x52	24
Electrical.....	1	22x38	24						
Auto.....	1	26x62	40	1	26x62	40	1	26x52	40
Print Shop.....	1	22x24	20	1	22x24	20	1	22x26	20
Machine Shop.....	2	22x40 22x50	24 24	1	22x40	24	1	22x40	24
Mechanical Drawing.....	2	22x40	70	1	22x40	35	1	22x40	35
Recitation Rooms.....	1	22x24	24	1	22x24	24	1	22x24	24

It will also be noticed that some rooms accommodate 40 pupils at one time. Mr. Trybom says there is a demand for larger sections in shopwork to correspond with conditions in other subjects. In view of this and his experience with large shops and two teachers, he feels justified in specifying the 40 unit in a few shops and the 70 unit in mechanical drawing.

TIME ALLOWANCE FOR SHOPWORK

ANOTHER group of facts in Mr. Trybom's report center around the time allowance for shop subjects. Four courses are offered in the intermediate schools: (a) General, (b) commercial, (c) technical, and (d) industrial or Smith-Hughes vocational. All seventh grade pupils get an average of four hours a week in general shopwork and one hour in mechanical drawing. For the next

year the general and commercial course pupils get one hour a week. That ends the shopwork and drawing for the commercial pupils, but the general course pupils get the same amount in the ninth grade. On the other hand, the technical course pupils get six hours of shopwork and two hours of drawing in the eighth grade and six hours of shopwork and three of drawing in the ninth grade. Students in the industrial course take fifteen hours of shopwork and two of mechanical drawing.

I was interested to learn that the quality of students in the industrial course is improving constantly. Mr. Trybom stated that the cause of this was probably due to a better understanding of the course and its specific aims. He did not indicate that it was due to changed economic conditions or to a re-

form in the habits of school principals who steer their undesirables into the industrial courses. Perhaps there are no such school principals in Detroit, or perhaps they have already been inoculated with some recently discovered vocational-guidance virus.

THREE DEFINITIONS

WHAT is in the minds of the school officials in Detroit in reference to the unity of the whole scheme of shopwork in the intermediate school is made clearer by the following quotation from Mr. Trybom's report covering definitions of terms:—

Manual training is general and cultural in its aims. It does not prepare for a definite vocation. From the practical point of view, its purpose is to teach what every man should know about the use of tools, especially in its relation to the care of a home. In the more advanced courses it aims to teach some general processes, pertaining to mechanical drawing and shopwork that will make the student better understand the general principles of construction, not with the purpose of making him a craftsman but an intelligent and practical citizen. The shopwork in the seventh grade of the intermediate school is manual training in the above sense; so are, likewise, the courses offered in the eighth and ninth grades in the general course, and in the eighth grade in the commercial course.

Technical training is intended to lay a broad foundation for all industries, and for such occupations as require a practical knowledge of the sciences. It is general training in the sense that it gives a student a good comprehensive training for the industries. Technical training supplemented by practical experience in the industries is intended to prepare for such positions as foreman and superin-

endent and such other positions as require a practical knowledge of technical and scientific principles. The subjects offered in a technical course include, not only the principal manufacturing processes of the important industries of the city, but such subjects as will give a basic knowledge of the scientific principles underlying the application of the arts and sciences to industry.

The technical course offered in the eighth and ninth grades is organized with this object in view, as introductory to the courses at the Cass Technical High School. The eighth grade course gives a student an opportunity to gain experience in some of the fundamental industries of the city; that is, machine shop work, electrical work, pattern making, automobile work, and printing. After these general experiences in these various occupations, a student may choose in the ninth grade the regular technical course leading to Cass Technical High School, or the limited industrial course leading more immediately to a vocation.

The term "industrial training" will be used in connection with our intermediate schools in a more specific meaning; it is vocational training in the narrow, limited or specific sense of preparing for some one particular trade or industrial occupation. The industrial courses offered in the ninth grade of the intermediate school are organized with this object in view; they are planned to give a preliminary training in a selected trade, such as machine shop work, electrical work, pattern making, automobile repair, printing, etc.

In general, we may say, therefore, that manual training has for its main objective the laying of the foundation for the training of a good citizen; technical training of a good minor executive or technical expert and industrial training of a good mechanic. It should be clearly understood, that as manual training is only one of the many avenues of training to the general objective of good citizenship, so, for specific efficiency, several years of practical experience must follow technical and industrial training to realize their specific objectives.

Be not wrapped up in the past; there is an actual present lying all about you; look up and behold it in its grandeur.

—LORD BACON.

A POINT OF VIEW

THE New York Bureau of Municipal Research of which William H. Allen is director presents a novel idea in advocating a "Happiness Survey" of our public school system in order to determine whether teachers are happy in their work. The announcement calls attention to the fact that altho the New York City schools pay relatively high salaries, there is no great influx of teachers from outside the city, seeking teaching positions, and that difficulty is being experienced in keeping up the quota in the local normal training schools.

A great deal of publicity has been given in the past three years to the shortage of teachers and the consequent need of larger salaries to attract and to hold able people in what is a most important public service.

While I agree that teachers' salaries have been and are now lower than they should be, I have held that the difficulty in securing teachers rested upon something deeper than merely the question of salaries.

Briefly and pointedly the shortage of women teachers is partially concerned with matrimonial opportunities. A man does not go to the schoolroom to seek a wife. While this lack of matrimonial opportunity is undoubtedly a drawback to women in the teaching profession, there are other deeper and profounder reasons for those who are seeking intellectual expression in their profession. The teaching of children consists in the imparting of knowledge and the drawing out of impulses of immature minds. The woman teacher is constantly dealing with intelligence vastly inferior to her own. The repetitive nature of the work, i. e., dealing from year to year with the same grade of intelligence which never once matches her wits against those of her pupils. These are the causes of the restlessness

and dissatisfaction of the better element of the teaching profession.

Not since my own school days have I spoken disrespectfully of the woman teacher. The sincerity, earnestness, and fine attitudes of those I meet in college halls have given me a light on their high living purposes and a deep respect for their professional standards.

I recall one day in the classroom that the question came up: "Why do people instinctively recognize a woman teacher and exhibit a tendency to disparage her?" I replied that there was the same disparagement of college professors and academic people in general. Who ever saw a cartoon of a librarian without thick eyeglasses and long hair, or one of a teacher who did not have either a very long or a very snubby nose? As for women teachers, I felt that the public thought of them as being in a dull profession and required them to act dull with the result that teachers made themselves look dull and finally they *became* dull. Both men and women were in the class and frankly discussed the question.

The question finally evolved as it very properly should, into consideration of its economic, sociological, and psychological aspects. We agreed that the profession was drab in spots. The reasons we did not know. We agreed that the public imposed a drabness of conduct and dress in that in some communities women teachers were criticized for dancing and wearing high-heeled shoes. In small towns the school committee frowns on fancy shirt waists, silk stockings, and short skirts. To marcelize or beauty-shop the head and to wear a picture hat would create a small-sized scandal in some villages. A teacher's permanent wave must be natural or not at all.

The factory type of girl goes to work

early, marries early, bears children early who go to work early. The store type of girl meets young men before work, in work, and after work. She imitates her smart customers in dress and manners. She is not adverse to false eyebrows and a lip stick.

The school teacher must prepare herself for a profession having exacting requirements. She spends, in this preparation, from four to six of the best years of her life more or less removed from conditions which lead to early marriage. Her first job in teaching may be a small village where boarding house life has few lines leading to amorous adventures. Or her first position may be in a large city where hours of travel to work, the work itself, teachers' meetings, calls of the supervisors and the requirements for higher certification, sap her energies and eventually her spirit. All of these things have a large bearing on the happiness survey of women teachers.

As for men teachers in public schools, I have never seen a caricature of such in the press nor a printed joke. These are reserved for the college professors. Men teachers either have a better chance than women teachers or else they make a better opportunity for themselves. Men's clubs meet in the evening. Women's clubs meet during a teachers working hours. There are few university clubs for women. Every large city has one for the men. There are no Chambers of Commerce and Rotary Clubs for women. Until recently men only have been promoted to the highest teaching and supervising positions. Some men carry on a side line of real estate or insurance or law in addition to holding a teaching position. Men make their work a profession and get ahead by it. The more that a woman makes hers a profession the farther she is removed from marriage.

Personally, I think that the woman teacher question needs a "happiness survey" plus an increase of salary. I doubt if male teachers in our lines of teaching interests need "happiness surveys." They only need a salary increase.

Teaching science, shopwork, mechanics, and agriculture has a lot of fun in it. I prefer side stepping the inspirational side of men teaching English and languages from a raised platform in a schoolroom. But what real enjoyment there is in these days of the new manual training and new science teaching to watch the keen interest of boys in making aeroplanes, kites, motors, boats, and going toys! The project teaching agriculturist with his Ford or Hendee visiting the farms of his boys has his professional tonic in ample doses. The present shopwork teacher has more projects set before his eyes by boys aspirations and by *Manual Training Magazine* inspirations than he can find place for in his "course of study."

I do not think the average manual training teacher needs a "happiness survey." He finds his joy in his work and in his boys. The vocational teacher is, or should be, in such close contact with industry that he is as happy as any industrialist. The vocational education administrator is, or is expected to be, an educational engineer. His financial return is far less than those who build bridges, subways, or canals, unless the latter be employed by the city, state, or national governments.

Men teachers should have more money, but there is a limit to public salaries. We need no "happiness survey." We know that our public job is not only a public trust but that it rests upon a personal choice for a reward not measured in dollars and cents.

—ARTHUR DEAN.

WASHINGTON CORRESPONDENCE

THE TECHNIC OF ARMY TRAINING

LAST month I referred to certain features of a circular prepared by the Civilian Advisory Board, describing the procedure adopted by the General Staff of the U. S. Army for the vocational training of enlisted men. I did not have space at that time to write of the suggestions to instructors.

The circular points out, first, that lesson outlines and textbooks "do not produce training." Their function is to define the objective toward which instructor and student must work, to indicate approved procedure, and to assign the successive tasks which must be performed in the process of achieving this objective. "Educational experience has demonstrated unequivocally that the more clearly the objective is defined and the more specifically the mission is described, the greater the success of instruction." This applies to the task of the instructor as well as to that of the student.

I have occasionally heard of a manual training teacher whose pride keeps him from knowing the service that can be rendered by a good textbook. As he sees it, no other teacher's ideas can be quite so good, or at least quite so well adapted to his particular situation, as those which he has himself evolved; and so his students' helps are confined to the outlines which he prepares. I think this an unfortunate attitude. The better the teacher the more uses he can find for good textbooks, and the more intelligent use he will make of them, and the more he will appreciate the real help they can be to him in defining the objectives toward which he is working.

PERSONNEL SPECIFICATIONS

ONE of the most important achievements of the Army during the war period was the development of a system of personnel specifications, which set forth clearly and definitely the personal characteristics, skill, and knowledge required for the successful performance of every type of service. These specifications serve two important functions: (1) They constitute an index or catalog, by means of which the commander of any given unit can prepare, as it were, an inventory of the men needed to accomplish the task or duty assigned to his command; (2) "They define the objective which training for every type of service must achieve." They serve as a guide for use in developing courses of instruction, and assist in the selection of men for various types of service.

In order to reduce the training period to the lowest possible terms, the specifications are limited to minimum requirements, or the lowest acceptable standards of skill and knowledge, and thus "make possible maximum thoroughness of training in minimum time."

The abilities required are classified as: (1) Personal characteristics, such as strength, nervous organization, and the like; (2) Skill, represented by a list of processes which a man must be able to do well; and (3) Knowledge, a list of things he must know.

APTITUDE TEST AND PROFICIENCY TESTS

THE Army plan includes series of objective tests, to supplement the results of interviews and various kinds of examinations, for the purpose of determining with a minimum of effort and time precisely what degrees of ability are possessed by individuals. These tests

are of two kinds: (1) Aptitude tests, designed to indicate whether the individual possesses a specific kind of ability needed; and (2) Tests of proficiency, intended to reveal relative degrees of proficiency for a specific ability.

The report points out that the validity of an objective test depends upon the determination of a "critical score," to mark the dividing line between proficiency and deficiency, and upon the accuracy with which this is done. "The selection of the critical score requires giving the test to a number of men whose relative proficiency has been judged by competent observers over an adequate period of observation. The validity of tests of proficiency thus rests on the judgment of competent observers. Their advantage lies in the fact that they enable an officer to secure quickly a proficiency classification which is as good as or better than he could secure in weeks by observation of the men on the job."

INSTRUCTION UNITS

FOR purposes of instruction the ground to be covered is broken up into convenient units. A "unit operation" is defined as a group of manipulative processes which is large enough to make a good instruction unit and which occurs frequently in substantially the same form, either alone or in combination with others, in the practical work of the trade. An "information topic" is a group of related facts, the mastery of which is essential to proficiency in a given grade or rating.

Analysis of the requirements of any given personnel specification gives a complete list of the essential unit operations and information topics, and sets the task for instructor and student.

In the application of the plan the instructor prepares or is supplied with: the list of unit operations and information topics required; operation sheets, which

give the directions for performing the unit operations; information sheets, which present and discuss briefly the necessary subject-matter; test questions, to stimulate study; and job assignment sheets, which are used in directing the activities of students. The instructor's rating card I described briefly last month.

The next step, upon which work is now going forward, is to keep careful records over sufficient periods to determine the average time necessary for the average beginner under an average instructor to attain given standards of proficiency, as shown by the objective tests. It is expected that some years will be required to complete this stage, altho tentative upper and lower limits may be set at an early date. When this information is available it will be possible to recommend that if an individual cannot attain a specified degree of proficiency within a certain number of hours, he should be assigned elsewhere.

Furthermore, when the plan is in full working order, it will be possible at any time to "set the date on which any specified number of men properly qualified for any rating can be delivered."

EDUCATIONAL SURVEYS MADE BY THE UNITED STATES BUREAU OF EDUCATION

A FEW days ago I prepared for Commissioner Tigert a memorandum listing the educational surveys which have been made by and under the direction of the Bureau of Education. I was astonished to find that the Bureau of Education has made or directed 84 surveys in 42 states, the District of Columbia, Hawaii, Porto Rico, and Canada.

The first of these surveys was that of the public schools of Baltimore, Maryland, under Commissioner Brown, in 1910, but about three-fourths of them have been made during the past five or six years. In every case the survey was

made at the request of the local authorities, such as the board of education, or the board of trustees, which is responsible for the school or system of schools to be studied. These surveys have included a number of distinct types, and may be classified as follows:

- (1) Surveys of state public school systems..... 9
- (2) Surveys of state systems of institutions for higher education..... 6
- (3) Surveys of individual institutions for higher education, or groups of such institutions... 23
- (4) Surveys of city public school systems..... 15
- (5) Surveys of public school building programs in cities..... 9
- (6) Surveys of public school systems of counties, or parts of counties..... 9
- (7) Miscellaneous surveys..... 13
- TOTAL..... 84

A survey may include within its scope a single school, a group of related schools,

or a system of schools in a city, county, or state. In some cases the survey has concerned itself with a single phase of the work of a school or school system, as school buildings, finance, or administration. In some cases the survey has dealt in a comprehensive way with all important aspects of public education in the political unit under investigation. And there have been intermediate degrees of comprehensiveness and thoroughness.

A survey of a single institution, or of limited extent, has sometimes been made by a single person in a few days' time. The survey of one state system of education occupied a staff of nearly thirty persons for two months or longer.

The Bureau of Education has usually contributed the services of one or more members of its staff, including the director of the survey. In many cases it has been necessary to supplement the services rendered by such members of the Bureau staff by employing additional persons from the outside.

—WILLIAM T. BAWDEN.

IN FOREIGN COUNTRIES

ENCOURAGING START MADE BY THE LONDON CONTINUATION SCHOOLS

AT A recent conference of welfare supervisors organized by the Industrial Welfare Society at Balliol College, Oxford, Dr. C. W. Kimmins gave a most optimistic view of the beginning of part-time continuation school work in London. He said,

I have never known an educational development start its course with such enthusiasm, both on the part of teacher and pupil. We were most fortunate in obtaining as principals and staffs for these schools men and women imbued with a true missionary spirit, with a broad outlook on education, good organizing ability, and with a calm determination to lay the foundations of the scheme wisely and securely. In consequence of the serious financial position with which the Council were faced, it was found to be necessary to limit the

scheme for the present to children of 14 years of age. Later on, when the financial position is less difficult, it will be extended to a two years' course, and it is hoped that at no very distant date the full four-year course outlined in the Act will be put in operation. I need not dwell upon the difficulties of buildings, unemployment, and the various adverse elements which naturally affected the first year of a new enterprise. Suffice it to say that continuation schools have now been definitely established in London, and have become vigorous institutions of very great promise.

PROOF OF THE VALUE OF GERMAN CONTINUATION SCHOOLS

DR. C. W. Kimmins of London has called attention to what he considers a striking proof of the value of the German day continuation schools. He is reported as saying,

"The most conclusive evidence, however, of the great value of the day continuation school is afforded by the object-lesson of Strasbourg. As you know, Strasbourg has, as the result of the war, been transferred to the French after a very long period of German occupation. Day continuation schools in this center had for some years been firmly established and incorporated in the school system. Naturally, as a result of the transference, very important changes were made in the organization of education. It might have been thought that the day continuation school, which was a foreign element, would have been swept away in the process of reorganization. The fate of this type of school was, however, never in doubt. It had so clearly proven its great value to employers and employed, and had become so popular, that no suggestion was even made for its removal from the school system. Further than this, it is stated to be more than probable that in the near future there will be a great development of this form of organization in other centers in France."

A NEW TRADE SCHOOL IN ALBANIA

AN article by Rose Wilder Lane in *The Oregonian* tells of a new "American industrial school" created by the Red Cross at Tirana, Albania. She speaks of it as the finest kind of contribution that Americans are making toward a better world. Miss Lane, who writes from Albania, reveals the striking contrast between Albania and America in the following excerpt:—

Somehow a school is not very interesting to the average reader. There is something a little dry and academic about the subject. But this industrial school, which thousands of anonymous Americans are building here on the other side of the world, in the capital of the oldest people and the youngest nation in Europe, fascinates me like a romance.

The first money for it has just come from Scutari which has the nearest bank. The hard round rolls of gold, in their canvas sack, came by automobile to the banks of the Mati river, were ferried across that rushing stream on the most primitive of ferries—a raft fastened to a cable and moved by

the current, and then in another automobile they came down to Tirana. Mr. Winfield, the treasurer, counts them out on the packing box table of his office, and there are American \$5 gold pieces among them.

Those hard, beautifully minted coins have come all the way from a country whose life is machinery; tractors on the farms of Kansas, automobiles on the roads, street cars in the cities, telephones, electric lights, sewing machines, water faucets, printing presses, telegraph wires, kodaks, moving pictures. They come from people who can hardly imagine a life without some machine, to a country where the simplest machine is beyond imagination, where a fountain pen seems magic and a needle is an important luxury to be treasured for years. Those coins are bringing the twentieth century into a bit of prehistoric Europe. They are presenting machines to young, fresh minds—eager, intelligent, questioning minds that have not been touched by all the changes of the world since before the days of Greece.

IMPORTANCE OF FUNDAMENTAL EDUCATION

THE inspector of industrial schools in Madras, India, Mr. W. Fyfe, has emphasized the importance of elementary education for artisans. This he says should precede industrial training. The *London Times Educational Supplement* says:

Mr. Fyfe lays down the axiom that if a boy has not had a general education before entering a workshop no amount of industrial training can make good the defect. His view is that the recruits for most trades should have a general education up to primary school standards, whilst those for the specially skilled trades should go up to the middle school or lower secondary standard. Their curriculum for the last three years should comprise four to six hours per week devoted to handwork and drawing whilst the exercises in arithmetic and elementary mathematics should be based on practical and not on abstract problems.

At the present time, Mr. Fyfe says, the Indian artisan is nearly if not quite illiterate. He started as a coolie boy and picked up his trade as best he could.

We have been thinking so much of cost, cost, cost, that we have forgotten to mention that it pays, pays, pays.

—R. L. COOLEY.

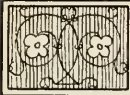

PROJECTS, PROBLEMS AND NOTES

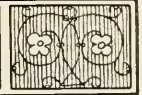

FIBER CHAIR SEATS WOVEN BY BOYS IN WOODWORKING CLASSES ANDERSON, INDIANA

MOST schools have experienced difficulty during the past year or two in meeting running expenses, and at present there seems to be a desire to keep expenditures as low as possible. But in-

Copula, or twisted paper was finally tried and proved successful. A hundred-pound bale was purchased and bundled in rolls just large enough for one chair seat.

The wood shop instructor declared an emergency, and regular work was put aside. Each boy in the class was given a chair and a roll of fiber and after

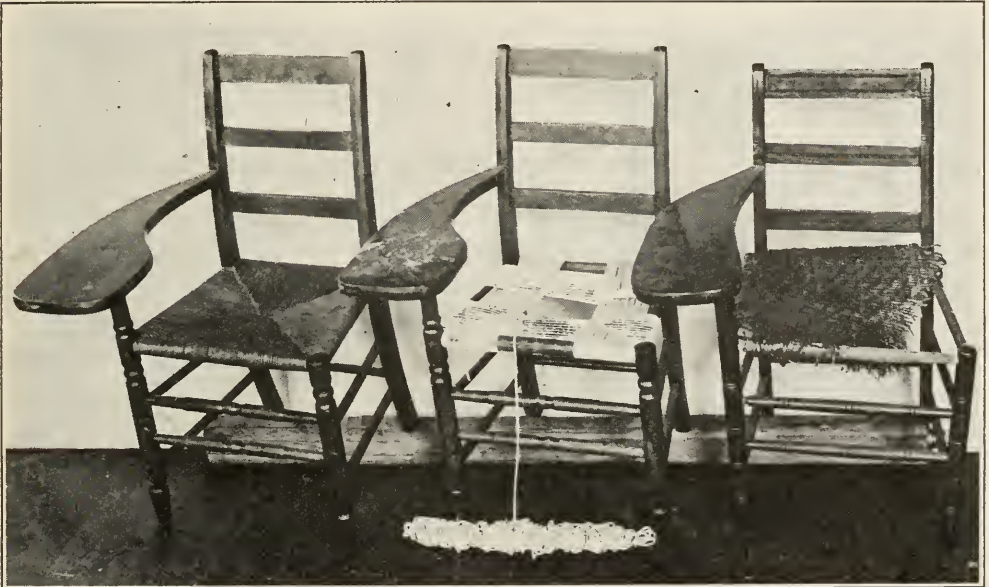

THE NEED, THE PROCESS, THE RESULT.

creased enrollments mean more equipment and teachers, and unless Anderson is an exception, all schools are having trouble keeping within the budget.

At the opening of the past term, it was necessary to provide three extra classrooms to take care of the extra number of students. Good chairs were difficult to get at any price, deliveries were slow and the need was urgent, so we set about to see what we could do to improve the situation. A visit to the attic disclosed the fact that we had quite a number of armed recitation chairs stored there, but an examination showed that practically all were disabled in some way. Most of them were bottomless, the cane having given out.

Quite a good deal of cane and reed had been used in the cabinet making classes for weaving seats in new furniture, but the process was too slow to solve this problem.

watching the operation for a few minutes was able to proceed himself. The result was that in a few days we had enough chairs re-seated to take care of the situation with a very small outlay of money. After the seats were woven they were given two coats of varnish. The boys enjoyed the work, as it did not last long enough to become tiresome, and the experience has enabled several boys to make expense money, taking in outside work.

—H. W. ROBERTS.

AUTOMOBILE PRACTICE WIRING

AUTOMOBILE wiring becomes mysterious when the student is required to trace out circuits on the car. But it becomes almost as simple for a boy as wiring a door bell when all the circuits are laid out in the open. He sees that the magneto, generator, starting motor, and lights will each function independently of the other. He learns rapidly to

visualize wiring diagrams, to make his own, and to trace those provided for each car.

The best way to provide that familiarity with the wiring is to permit the student to set up the electrical equipment in a manner resembling the arrangement of the individual pieces on the car. Place dash instruments and wire at his disposal. Then observe how quickly he will coordinate the theory with practice.

benefit bazaar held in the Hudson, New York, High School in November.

The exhibit in the Chamber of Commerce window was arranged as an advertisement and attracted much favorable attention, thereby serving two ends—advertising both the bazaar and the work of the pupils. The boys in the carpentry shop made furniture, desk sets, toys of all sorts, sconces, novelties; also flower boxes, bread boards, letter holders, etc.,

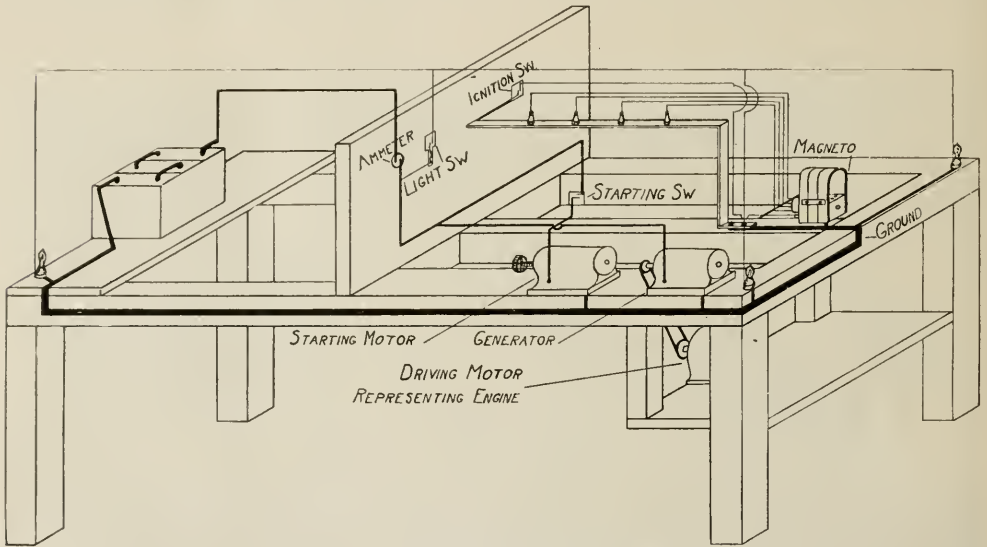

APPARATUS FOR TEACHING AUTOMOBILE WIRING.

A simple layout for such a wiring problem is illustrated in the drawing herewith. This shows a wooden frame, with dash, resembling the frame of a car. The motor, generator, magneto, lights, and instruments are mounted conveniently by the student, and each is wired separately. Each must function properly and check with the student's own wiring diagram.

The drawing shows only one of several representative systems of wiring. The diagrams for each may in turn be drawn, and the equipment set up and tested.

—FRANK C. VINCENT
Vallejo, California.

THE INDUSTRIAL ARTS DEPARTMENTS AND THE SCHOOL BAZAAR

THE school bazaar offers a fine opportunity for co-operative work among the various industrial departments of the school.

The accompanying picture (see next page) shows but a small part of the articles made by the carpentry, art and home-making departments for a library

which were decorated by the art department. The art department also made stencils, and in other ways assisted the home-making department, which contributed school bags, aprons, laundry bags, hand-made yokes, doilies, etc.; plum pudding, jam and marmalade, and cakes.

—KENNETH R. LA VOY,
Instructor of Industrial Arts,
Hudson High School,
Hudson, New York.

CHILD'S ARM ROCKER

THE accompanying design of a child's arm rocker, seems to be an answer to the constant question, "What can I make for my kid sister?" It looks well when made up, and is enough of a novelty to appeal to the average boy who is far enough advanced in his course to make good mortise-and-tenon joints.

While oak or walnut seems to be the best material for this rocker, red gum will be satisfactory if a mahogany finish is desired.



SHOW WINDOW ADVERTISING SCHOOL BAZAAR AT HUDSON, N. Y.

The dimensions given are not inflexible, and will allow considerable variation, depending upon the size of the child.

The entire chair can be made of $\frac{3}{4}$ " or $\frac{7}{8}$ " stock, with the exception of the front legs. (These front

legs can be turned, in shops equipped with lathes, to excellent advantage).

The back slats are $\frac{3}{8}$ " thick.

The rockers are swung with a 24" radius, and can be made with minimum waste if both are band-

sawed from the same board, using the top curve of one as the bottom of the other. A spoke-shave or wood rasp, and sandpaper block will true them to their lines.

The seat can be regularly upholstered with a box spring slip seat, or can be a padded board seat,

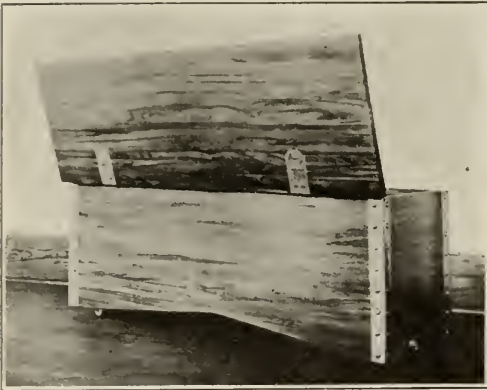

GUMWOOD CHEST.

resting on corner braces placed inside the seat rails.

The arms should be fastened as shown in the arm detail. The rockers are fastened on with screws and may, or may not, be fitted to the legs.

The arms can be shaped to suit the builder.

E. C. POWELL, Massillon, Ohio.

GUMWOOD CHEST

FIGURED red gumwood can be used to great advantage by manual training students to construct chests, tables, chairs, etc; the wood being soft, beautifully grained, easy to work with, and capable of taking a high polish. This wood is better unstained, for the natural finish is too beautiful to be given an artificial tint.

The gumwood chest, shown in the accompanying photograph and working drawing, was made from a single board 16" wide and 14' long. Sixteen inches being the width of the chest, the board was wide enough to avoid the necessity of jointing. A cedar bottom serves the same purpose as a whole cedar chest.

When finishing, the chest was dampened, steel-wooled, and sand-papered for several successive days. The dampening raised the grain of the wood, until finally it presented a hard, glossy surface. A coat of paste filler was applied, after which the wood was shellacked and rubbed with steel wool, then shellacked and rubbed the second time. The corners were bound in copper, which gives the chest a "factory-made" appearance.

—TRESSA ROBERTS,
Consolidated School, Webb, Iowa.

STONE BUILDING BLOCKS

THE accompanying photograph of a church was received recently from William Jay Dana of Raleigh, N. C. Mr. Dana said in the letter accompanying the picture, "After seeing your special toy-making number of November I thought you might want to publish this to show your readers what can be done in modeling with stone building blocks." He uses what he calls the Anchor Stone Building Block, many of which he has had since he was a boy. The stones are simply laid carefully one on top of another as in building with any toy blocks. He builds on a 23" x 31" drawing board kept level.



MADE WITH STONE BUILDING BLOCKS

MATCHING MAHOGANY FINISH

Question:

We are making some music cabinets out of poplar. Some of it is white and some yellow. We want to finish it mahogany to match as near as possible other furniture which is of mahogany color.

Please tell me what to use to finish the cabinets with.

—E. H.

Answer:

1. Determine the kind of finish to be matched. Is it a varnish, shellac, or wax finish? Has it been produced by staining, shellacking, and varnishing; or staining, shellacking, and waxing; or by staining, and merely shellacking?

CHILD'S ARM ROCKER.

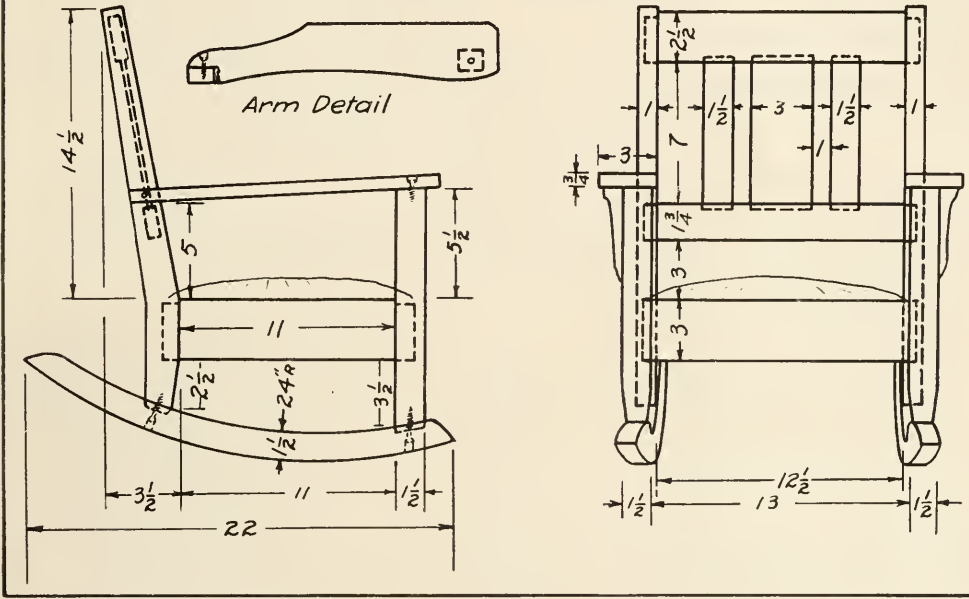

CHEST

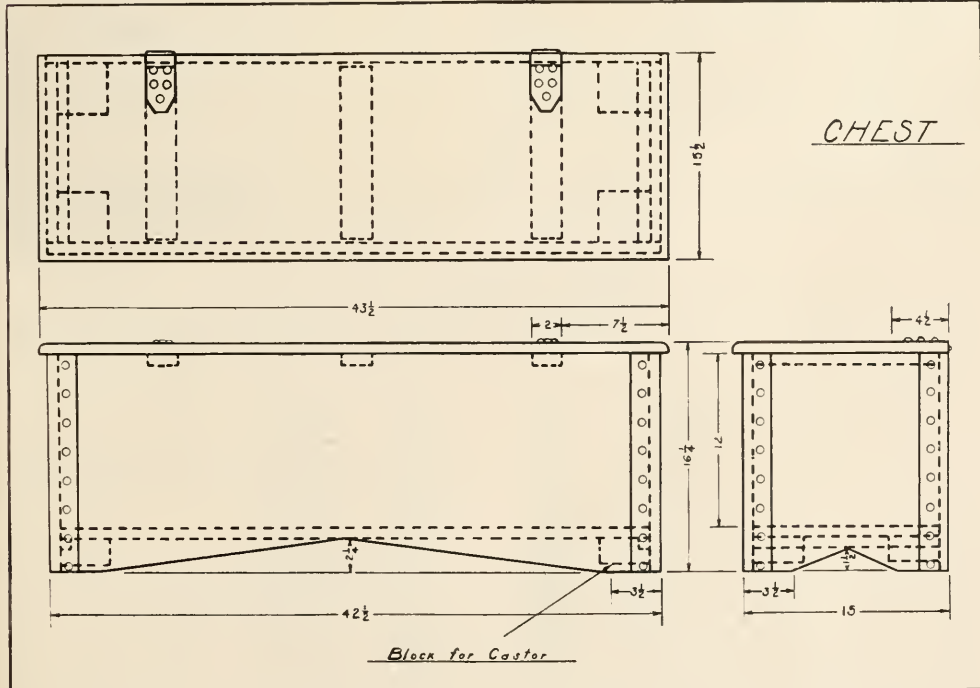

Block for Castor

2. Determine the color and shade to be matched. Is it red mahogany or brown mahogany?

3. Take a stain solution a little darker or deeper shade than the color to be matched. If you find this in a commercial Mahogany stain it will mean

of water. Prepare a board for finishing 4" wide by 15" long. Lay out 3" lengths along this board, and stain the five spaces with the five portions of stain. When dry finish the board with the same surface coats as is on the furniture to be matched.

This will make it possible for you to pick out the strength of stain which comes nearest matching. Prepare enough of this dilute stain and proceed to produce the required finish.

The test board of course should be of the same wood as the new furniture.

—E. A. JOHNSON,
Bradley Polytechnic Institute.

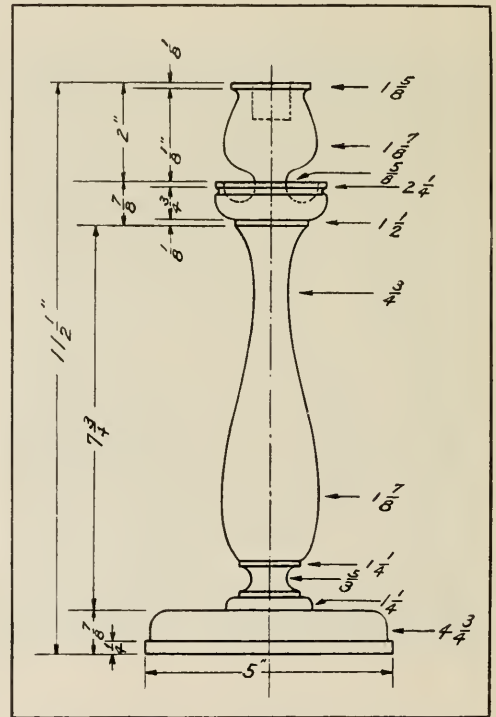
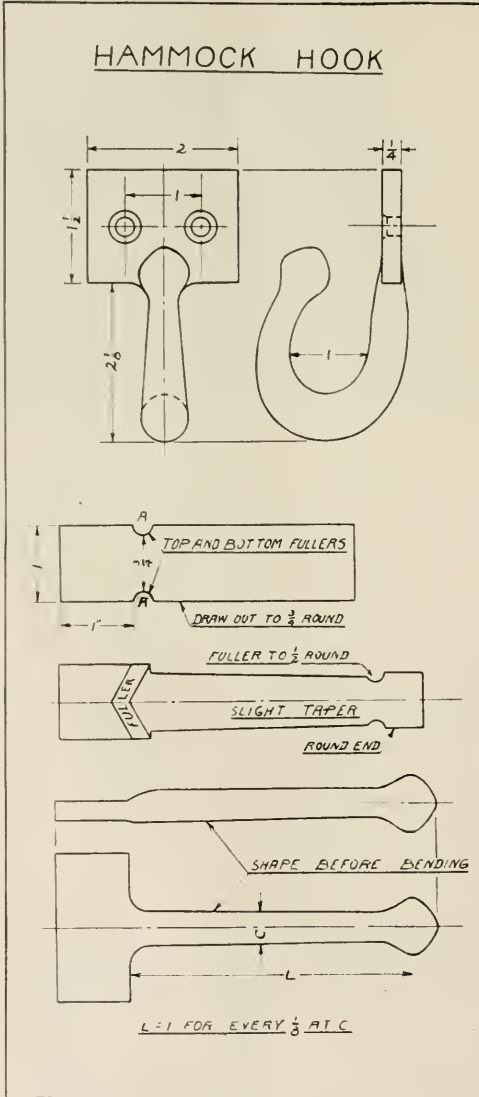

WAX-CATCHING CANDLESTICK DESIGNED BY
PAUL V. WOOLLEY, MUNCIE, IND.

HAMMOCK HOOK

THIS design has been submitted by Griffith E. Owen of the Union High School, Grand Rapids, Michigan.

The steps in forging it are

1. Fuller shoulder at A.
2. Draw shank to 3/4 round.
3. Cut off to approximate length.
4. Make ball and taper at end.
5. Shape flat end.
6. Bend to shape.
7. Drill holes for screws.

less work for you; if you cannot, you may take 1 qt. water to which add 1/2 oz. brown mahogany 1/4 oz. red mahogany, 1/8 oz. bichromate of potash. If you have not the above but have Bismark brown aniline prepare a saturated solution with hot water.

Pour out five small portions. To the first portion add 25 per cent, to the second 50 per cent, to the third 75 per cent, and to the fourth 100 per cent

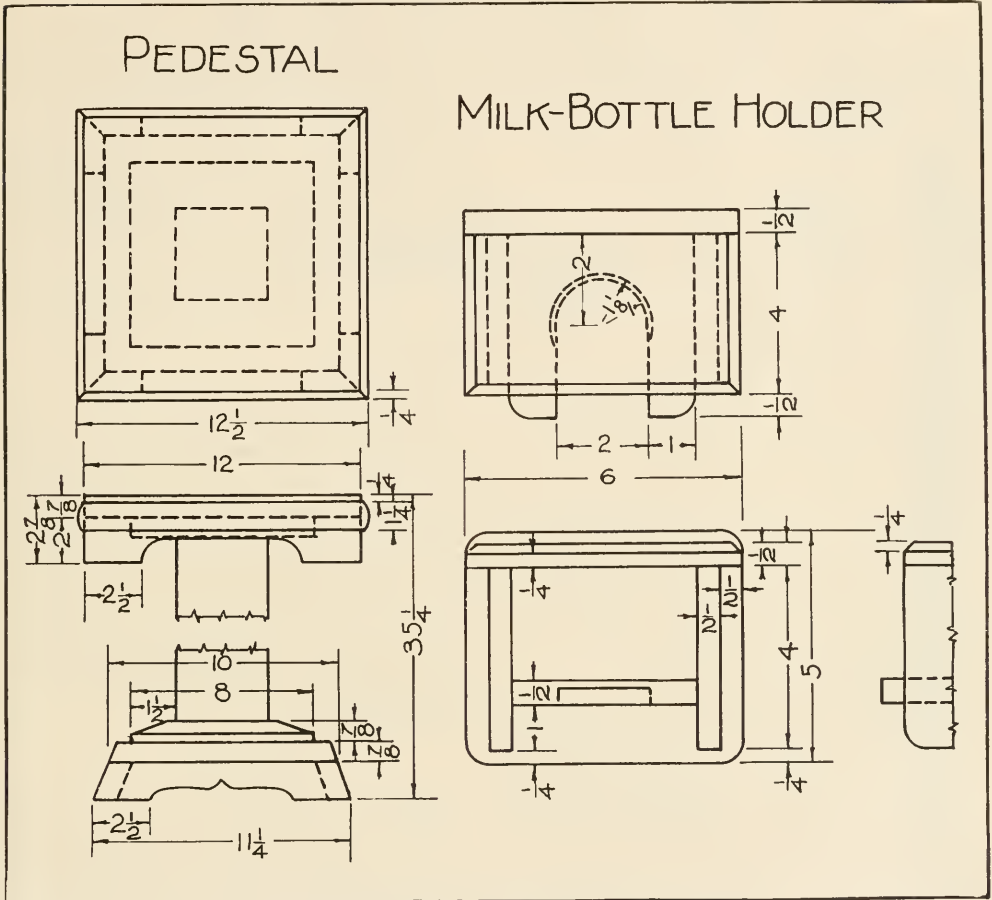

MILK-BOTTLE HOLDER AND PEDESTAL

These two problems were received from Fred A. Campbell, manual training instructor, Owen Sound, Ontario. He says that both of them have been successful problems in his classes. The milk-bottle holder is a Grade VII problem and the pedestal a first-year high school problem.

EVOLUTION OF A SCREW.

SAD FATE OF A "HIELANDER" AND SOME OTHER MEN.
 His iron constitution Rusted by the rain Gradually turned him Into a screw.

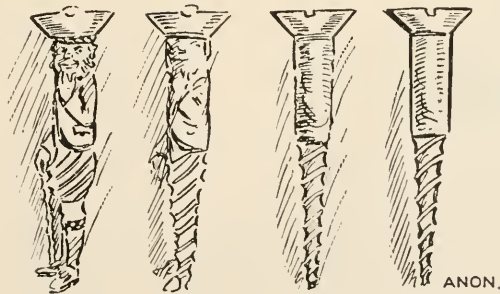

COPIED FROM "MANUAL TRAINING", ENGLAND.

CURRENT PUBLICATIONS

The Welding Encyclopedia. Compiled by L. B. Mackenzie and H. S. Card, of the editorial staff of *The Welding Engineer.* Published by The Welding Engineer Publishing Co., Chicago. Size 6 x 9; 326 pages; 375 illustrations; price \$5.00 postpaid.

This is a reference and instruction book on autogenous welding covering the subject from many different angles. About one-third of the book is made up in the form of a dictionary defining terms and processes and also giving short treatises on methods used in welding. Various sources of heat used in welding, as oxy-acetylene, electric arc, etc., are then discussed. Government, state, and insurance rules for installation and operation of welding equipment are next treated; while the last part is a catalog section in which appear announcements of a large number of manufacturers of welding equipment and accessories. The book will be a valuable asset to the commercial welding shop or to the school where the subject of welding is taught.

Drawing Room Practice. By Frank A. Stanley, editor *Western Machinery World.* McGraw-Hill Book Company, New York, 1921. Size 6 x 9 in.; 253 pages; 487 illustrations; price \$2.50.

This is a text and reference book on the making of various kinds of drawings, from the most elementary instruction in the use of drawing instruments to the complete assembly of working drawings of many types. A chapter on tool drawing, and one on limit dimensions on drawings are features of this book, which, in addition to the well organized material bearing on general drafting practices, should give it an equally warm reception among both the students of drawing and those who are engaged in commercial drafting as an occupation. An abundance of photographic illustrations aid very materially in explaining the principles of drafting set forth in this book.

Machine Drawing. By Carl L. Svendsen, Assistant Professor of Engineering Drawing, Ohio State University. Published by D. Van Nostrand Company, New York, 1921. Size 6 x 9 in.; 216 pages 388 illustrations; price \$2.25.

The purpose of this book, which is a text and problem book for technical students and draftsmen, is to offer a guide for the development of an understanding of the relation of machine drawing to engineering.

The work covered is intended for students who have mastered the elementary principles of mechanical drawing, altho Chapter I deals with elementary principles of drawing for the purpose of review and reference. Taken as a whole, the book presents a thoroughgoing instruction manual on all phases of machine drawing.

Loose-Leaf Laboratory Manual. Report blanks Nos. 1 and 2. By B. D. Burling. The Bruce Publishing Company, Milwaukee, 1921.

No. 1 devotes two pages to an experiment. On these two pages are spaces for records of different sorts and especially a table for test data, a place for statement of theory, and another for the results and conclusions. No. 2 devotes four pages to an experiment, and in addition to the items in No. 1, gives a table for calculated data, and a cross-section sheet for the plotting of curves. These books are therefore adapted to almost any kind of laboratory experimental work.

Forge Note-Book. By Geo. J. Coleman, Lane Technical High School, Chicago, Illinois. Published by The Bruce Publishing Company, Milwaukee, Wisconsin, 1921. Size 9¼ x 5¾ in.; oblong; 26 pages; illustrated; price 35 cents.

This is a reference note-book giving instruction in the fundamental facts about the use of the forge, the names of the forge tools, etc. In addition to this it offers a short discussion of the metallurgy of iron and steel. The latter part of the book contains directions for a number of the most common forging operations, with instruction on hardening and tempering.

RECEIVED

Milk and Its Use in the Home. Farmers' Bulletin No. 1207. Issued by the U. S. Department of Agriculture, Washington, D. C.

Wood for the Nation. By W. B. Greeley, forester. Separate No. 835 from the Yearbook of the U. S. Department of Agriculture, 1920.

A Unit Course in Swine Husbandry. Bulletin No. 68. Issued by the Federal Board for Vocational Education, Washington, D. C.

Experimental Methods and Tests. The spring, 1921, number of *School and Home* published by the Parents' and Teachers' Association of the Ethical Cultural School, New York City.

Announcement of Industrial Teacher-Training Courses in the State Normal and Training School, Oswego, New York.

Better Foremanship. A series of carefully prepared pamphlets. Issued by the American School of Correspondence, Chicago.

Twenty-first Annual Report of the Director of Education, Philippine Islands. Issued by the Department of Public Instruction, Manila, Philippine Islands. This is an interesting, illustrated report giving much information concerning practical education in the Philippines.

LUMBER

JOSEPH N. DION, Pres. & Treas.
EDWIN C. SALVESEN, Secty.
F. FRED TAYLOR, Vice Pres.

Maisey & Dion
Hardwood Lumber



OFFICE AND YARDS.
2349 TO 2423 S. LOOMIS ST.

TELEPHONES: (CANAL 1830
(CANAL 1831
(CANAL 118

CHICAGO.

Dear Manual Training Supervisor:

Is lumber buying one of your WORRIES?

If so, why not eliminate the wear and tear on your nervous system by ordering from us?

During the past seventeen years we have taken care of an ever increasing number of schools to their complete satisfaction.

Our stock includes lumber of all kinds, grades and sizes to meet school needs.

No filling orders in a slipshod or haphazard manner in our institution.

Our yard superintendent exercises close supervision over the SEASONING, KILN DRYING, INSPECTING, MEASUREMENT, AND SHIPMENT of all orders. This insures you mighty good value.

We do not issue stock nor price list, each order is given individual attention. Please advise number of feet and kind of lumber wanted and we will gladly quote you.

Awaiting the opportunity of serving you, we remain,

Respectfully,

MAISEY & DION

J. H. Dion Pres.

MAISEY & DION — HARDWOOD LUMBER
2349 to 2423 South Loomis Street
CHICAGO

OUR NEW
CATALOG
OF
TOOLS
AND
BENCHES

WILL BE READY
IN A FEW WEEKS

We would like to register
your name for a copy.

Simply mention
Catalog No. 235

Since 1848 we have adhered to
one policy—to handle only
the very best in quality

Hammacher
Schlemmer & Co.

Hardware, Tools and
Supplies

New York Since 1848

4th Ave. and 13th St.

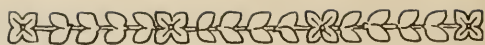

FIELD NOTES—(Continued)

GOVERNMENT NEED FOR WORKERS
IN REHABILITATION

THE United States Civil Service Commission states that there is urgent need for reconstruction assistants and aides in physiotherapy and occupational therapy, trained nurses, and physicians, to serve in hospitals and other establishments of the United States Public Health Service and the Veterans' Bureau, in the care and rehabilitation of men injured in the World War. The Commission has announced that it will receive applications for these positions until further notice. The applicants will not be given written scholastic tests, but will be rated upon their education, training experience, and physical ability.

Full information and application blanks may be obtained from the United States Civil Service Commission, Washington, D. C., or from the Secretary of the Local Board of Civil Service Examiners at the post office or customhouse in any city.

NEW FEATURES
IN CORRESPONDENCE STUDY

THE Industrial Correspondence University of Philadelphia, which is a lately organized school of correspondence, confining itself to industrial subjects only, has announced two rather new features in this line of education which will commend themselves to prospective correspondence students. While the custom of this type of school has been to sell the whole course of instruction and collect the price in full regardless of whether the person buying it would be likely to work thru one-fourth, one-half, or all of the course, this business has now been brought to a more humane level so that the student may buy the instruction a section at a time. If the student cares to continue the study, he will buy another section and then another until the

**Build Your Own
PHONOGRAPH**

Instructive—arouses pupils' enthusiasm—provides one of the best problems in cabinet making.

Let Your Pupils Build
Choraleon Phonographs

We furnish plans, blue prints, motors, tone arms, case material—in fact, everything required. Full instructions. Choraleon's have fine tone. Play any record. Ask for particulars.



CHORALEON PHONOGRAPH CO.
222-7th St., Elkhart, Ind.

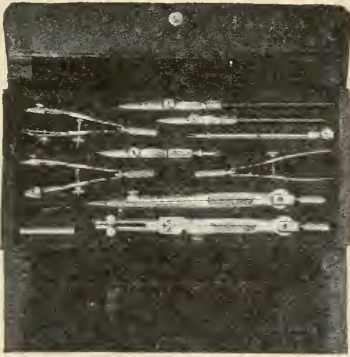

ORDER NOW—DIRECT FROM US
Mechanical Drawing Instruments
 AT OUR ATTRACTIVE WHOLESALE PRICES
 AND SAVE ONE-HALF OF RETAIL PRICES

Set of Instruments as per Photo \$6.00

Construction of Solid Nickel Silver and Steel—Pocket Case 8½ Inches by 4 Inches, and Lined with Velvet.

A Set of Instruments Every Manual Training Student Can Afford—at a Big Saving and Perfect Satisfaction

Send for Catalog on Other Sets and Supplies

National Instrument Company

4700 North Hamilton Ave., Dept. F., Chicago, Ill., U. S. A.

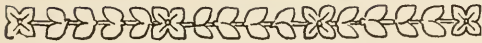

FIELD NOTES—(Continued)

whole course is completed. If he finds it impossible to continue, his financial loss will be much less than under the old method.

As a second feature, this school has made all of its lessons and literature available to anyone who wishes to buy them without having to accept the services of the school in carrying out the work. This will be particularly appreciated by schools which may wish to use this material for the purpose of instruction and reference.

ITEMS OF PROGRESS

A NEW JUNIOR HIGH SCHOOL BUILDING

In Saginaw, Michigan a new junior high-school building of the most modern type is being erected. The estimated cost of the plant is one million dollars. Ample provision has been made in the plans for industrial and home economics activities. Woodwork, forging, general shop work, tinsmithing, and household repairs are among the courses provided for. When this building is completed and equipped, Saginaw will be in the front ranks with reference to a junior high-school organization. Howard Hollenbach, the assistant superintendent of schools is director of manual art.

GLUING CLAMPS



We make the best clamps for every purpose; ask for *Bulletin 11-B*

Steel Bar Wood Bar
 Column Mitre

THE BLACK BROS. CO.
 Mendota, Ill. U. S. A.

Machines and Tools for Sheet Metal Working Courses

We have had years of experience in furnishing complete equipments for Sheet Metal Working Classes in institutions and vocational schools.

Let us quote on the tools and machines that you need. Write for complete illustrated catalog No. 56.

Niagara Machine and Tool Works

Established 1879

BUFFALO, N. Y., U. S. A.

NIAGARA

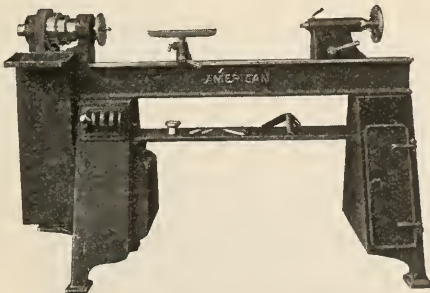

Manual Training Lathe with Motor in Base—24" to 72" Centers

AMERICAN School Equipment

High Quality Machines at Moderate Cost

SAW BENCHES
 JOINTERS
 PLANERS
 BAND SAWS
 WOODWORKERS

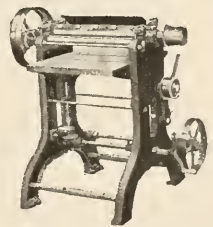

AMERICAN SAW MILL MACHINERY CO.

142 MAIN ST., HACKETTSTOWN, N. J.



Are
You Using the
**French
Drawing Series?**

There is just one reason for the great success of the French Drawing Series—teachableness. These books anticipate the troubles of teacher and student—they are based on wide experience—and they have all been thoroughly tried out in class work before publication. Of the latest number in this series—French and Turnbull's **LESSONS IN LETTERING**—Industrial-Arts Magazine says, "The books appeal to us as the most readily teachable lettering books produced up to this time."

FRENCH and TURNBULL—

Lessons in Lettering. Book I—Vertical. Book II—Slant. 35 cents each; per doz., \$3.60.

A series of practice books with text, examples and exercises. Already in use in 55 schools and colleges.

FRENCH and SVENSEN—

Mechanical Drawing for High Schools, \$1.50. More widely used than all other books of its kind together. Write to us for a list of the schools in your state that are using French and Svensen.

FRENCH and IVES—

Agricultural Drawing and Design of Farm Structures, \$1.75.

FRENCH and MEIKLEJOHN—

Essentials of Lettering, \$1.50.

FRENCH—

Engineering Drawing, \$3.00.

FREE EXAMINATION COUPON

McGRAW-HILL BOOK CO., Inc.
370 Seventh Ave., New York

You may send me on 10 days' approval

.....

.....

I agree to pay for the books or return them, postpaid, within 10 days of receipt.

Signed

School

Official Position

Address

.....

M. T. M. 2-1-22

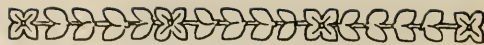

FIELD NOTES—(Continued)

CANTON, SOUTH DAKOTA, TO HAVE NEW BUILDING

The board of Education of Canton, South Dakota, has advertised for bids on a new junior-senior high-school building. The cost of this building will be \$165,000. The plans include rooms for home economics, woodwork, drawing, with a special room for shop work of a more general nature—repair work on farm machinery, gas engine operation and repair, etc. Courses both in home economics and in industrial work will be organized under the provisions of the Smith-Hughes law.

UNION HIGH SCHOOL PROSPEROUS

A good example of the modern spirit of social progress in a rural community is found in the development of the Live Oak Union High School at Morgan Hill, California. In 1905 the number of pupils enrolled was 42; now it is 135. During this period, thru the efforts of progressive citizens who have served on the school board, a bond issue of \$45,000 has made possible the erection of three spacious buildings. The school now has modern facilities for teaching the sciences, a fine gymnasium, a shop 40 by 72 ft. Instruction is given in wood-working, forging, electricity, machine tool work, repairing farm machinery, and especially in automobile and gas engine repair work. Lewis H. Britton is principal of this model school.

NEW BUILDING ADDED AT KANSAS NORMAL SCHOOL

Plans are being completed for a new gymnasium building at The Kansas Manual Training Normal School at Pittsburgh, Kansas. The state legislature recently appropriated \$100,000 for this project.

EXAMINATION FOR TEACHERS ANNOUNCED

An examination for teachers in manual training and domestic science subjects in the elementary schools of Jersey City will be held in Jersey City, Saturday, February 18, for men and women respectively. The salary schedule for these positions

**Give Your Pupils
SHOP-WORK THAT PAYS**

Let the Boys Build Phonographs

Imagine the pride and joy of your pupils in building their own phonographs (equal in quality to high-priced standard machines) either to sell or take home as a source of lasting pleasure. Think how this project will add to your popularity as an instructor. Building phonographs is easy, by our methods, yet it demands precision and delicacy of workmanship, the very points always emphasized in shop practice.

Send 10c for fine illustrated catalog

and full information about our co-operative plan for manual training teachers. We plan the work for you. We supply blueprints, tone-arms, motors, case material and all accessories at lowest prices. Detailed instructions furnished. Materials best obtainable, fully guaranteed. Our machines play any make record. Write us TODAY.

HOOSIER MANUFACTURING & SUPPLY CO.
PHONOGRAPH SUPPLY DEPT.

315 Baldwin Block, Dept. A. Indianapolis, Ind.

CRANE'S "JUNIOR" BENCH SAW

This high grade, accurate and fully guaranteed machine is constructed entirely of metal. It is well adapted to both wood and metal sawing.

Table top is 10" x 13" and can be tilted on either side to any angle up to 5 degrees for drafting patterns, etc. Top can also be adjusted to any height for grooving, etc. Slot is wide enough to accommodate 3-16" grooving cutter. Weight is 40 pounds. Other details on request. I also manufacture a full line of plain and ball-bearing motor-driven bench saws and disc sanders, etc. Send for circulars.

HAROLD G. CRANE,

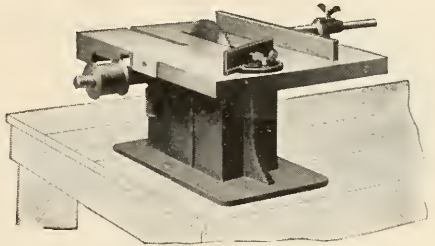

Adrian, Michigan

The Near East Relief

is now feeding 100,000 orphaned children, innocent victims of the Great War. Without American relief they must perish.

Let your school assist in saving a few of these little lives by making known the facts—
They are Human Facts—Vital Facts—Facts involving humanity.

For free literature address

THE NEAR EAST RELIEF
151 Fifth Avenue
NEW YORK CITY

Cushions, Spring Seats Upholstering Supplies

We issue price list which also contains valuable information for Instructors in Manual Arts.

It is free—write for it.

DODGE-DICKINSON CO.
Bloomington, Illinois

SIMPLIFY GRINDING

With Mummert-Dixon Oilstone Grinders. Five wheels for almost every class of grinding. They accomplish the work quickly and accurately. With this machine your students can experience the pleasure of sharp tools.



The Modern
Edge Tool
Sharpening
Machines.

The
Standard
for all
Industrial
Schools

Five
Leading
Features
Coarse Oilstone
Wheel
Fine Oilstone
Wheel
Emery Wheel
Grinder
Cone
Leather
Wheel

Furnished for motor drive or with counter-shaft
Send for full descriptive bulletin

MUMMERT-DIXON CO., Hanover, Pa.

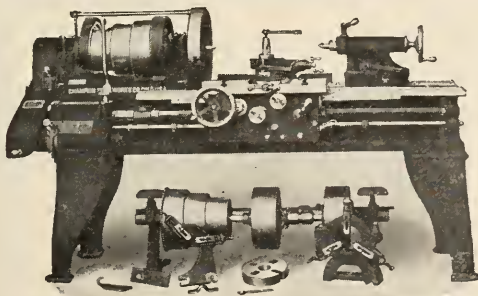

Champion Lathes

A quality engine lathe, accurate, convenient to operate and at a very attractive price to manual training and vocational schools.

Made in four sizes: 13", 15", 17" and 19"

Champion Tool Works

Winton Place

Cincinnati, Ohio

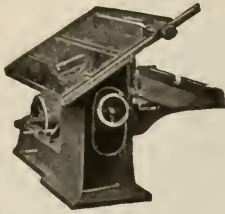

Crescent Wood Working Machines

are the tools your students will eventually use so give them the opportunity now of learning about this splendid line of wood working machinery.

Send today for our catalog of band saws, jointers, saw table, shapers, variety wood workers, planers, planers and matchers, cut off saws, disk grinders, borers, hollow chisel mortisers, Universal wood workers.

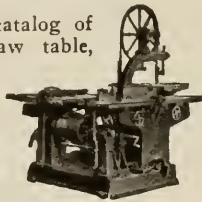

The Crescent Machine Co.

46 CHERRY ST. LEETONIA, OHIO



Manual Training Bench, No. 16

which is furnished with one Abernathy Rapid Acting Vise, and with one drawer.

Ask for our new Catalog No. 27

C. CHRISTIANSEN
BENCH MANUFACTURER

2814 W. 26th St. CHICAGO, ILL.

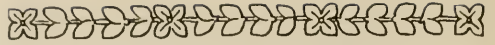

FIELD NOTES—(Continued)

goes to a maximum of \$2600 for men, and \$2100 for women. Examination will be held in the Lincoln High School. Candidates should make application in advance to Ernest B. Kent, director of manual and industrial training.

APPOINTMENTS

ROY B. SMITH who has served as one of the teachers of manual arts in the schools of Little Rock, Arkansas has severed his connection with that institution and is now Training Officer, U. S. Veteran's Bureau. Mr. Smith is located at Waco, Texas.

FRED J. EVANS, formerly connected with the Port Arthur Collegiate, Port Arthur, Ontario, is now in charge of the woodworking department of Sudbury Technical and Mining School, Sudbury, Ontario.

JAMES E. GOFFREY, who has held the position of instructor of printing in the Atlantic City Vocational School has accepted a position with the United Typothetae of America. His position is that of educational director for this organization for central Pennsylvania. The headquarters for Mr. Goffrey's office is 316 Telegraph Building, Harrisburgh.

A CHANGE HAS BEEN MADE in position by Arthur L. Norvell who has been director of manual training in the public schools of Shelby, Montana. He is now director of the department of commerce in the high school of the same city. Mr. Norvell is a graduate with a B. S. degree from the Bradley Polytechnic Institute.

TRADE NOTES

COMMERCIAL EXHIBIT AT MILWAUKEE CONVENTION

THE Milwaukee convention of the Vocational Education Association of the Middle West was a signal success with the exhibitors. Few conven-

Marqueterie, Inlay Borders and Purflings for

Manufacturers and Vocational
Schools

Insets for Trays, Panels, Cabinets, etc. carried in stock.
Natural and Transformed Veneers in great variety.
Lines in Holly, Satinwood, Box, Mahogany and Black

J. BERNARD CO.

422 to 30 East 53rd St. New York

THE SAFETY ELECTRIC GLUE HEATER

is in use in wood-working and print shops all over the United States. The Old way of heating glue over a gas plate or gasoline stove has passed. Modern days demand a more efficient and safe method.

You know how essential it is that your glue be kept and applied at the right working temperature or poor results follow.

The *Moist* heat of the Safety Glue Pot is regulated—It Runs Itself.

Let us send you a descriptive circular.

SAFETY ELECTRIC HEATER CO.
FARIBAULT, MINN.

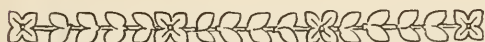

TRADE NOTES—(Continued)

tions are so fortunate in the space available for exhibits. Englemann Hall, in which the exhibits were placed, is a delightful room on the same floor of the Auditorium as Plankinton Hall where most of the meetings were held. Each year finds this convention more popular with commercial exhibitors and this year even adjoining committee rooms and stair landings had to be utilized to care for the increasing members. All spaces were good, both for display, comfort and for convenience.

The exhibit of Fay & Egan Company attracted much attention. Attractive souvenirs, cherished by visitors, were turned to demonstrate their No. 400 Type D. wood lathe. Included in their exhibit was their No. 500 Variety Saw, No. 502 Bench Jointer, and No. 472 Vertical Hollow Chisel Mortiser. The display was in charge of W. J. Hoth and F. T. Crane.

The exhibit of Stanley tools in cabinets, boxes and sets attracted much attention. This was the first convention at which Stanley tools in this new and attractive form have been shown. E. A. Cherry, the originator of Stanley tools in cabinet, was there to explain to visitors their many points of merit.

The American Type Founders Company of Jersey

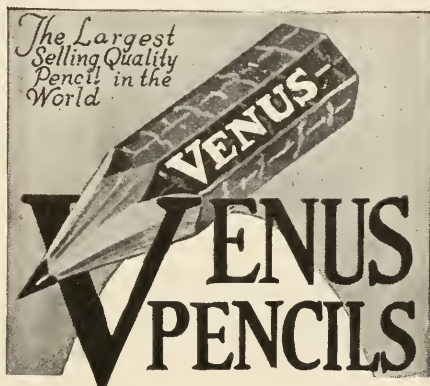

FOR quick rugged sketching or the fine detail of lettering or decoration—there is a VENUS Pencil for every pencil purpose.

17 black degrees, 3 copying

For bold, heavy lines	6B-5B-4B-3B
For Writing, sketching	2B-B-HB-F-H
For clean, fine lines	2H-3H-4H-5H-6H
For delicate, thin lines	7H-8H-9H

Plain Ends, per doz.	\$1.00
Rubber Ends, per doz.	1.20

At Stationers and Stores throughout the World

American Lead Pencil Co.
219 Fifth Ave., Dept. A., N.Y.
and London, Eng.

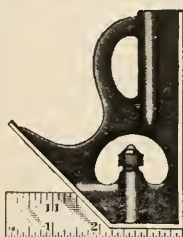

NEW LUFKIN

**“UNIVERSAL”
TRY AND MITRE
SQUARES
FOR WOODWORKERS**

**HIGH GRADE YET POPULAR PRICED
ACCURATE—DURABLE—WELL DESIGNED**

No. 65L—WITH LEVEL

No. 65—WITHOUT LEVEL

Made in 9-inch and
12-inch lengths

Distinct marking; movable yet secure head. Serves also as marking, height and depth gauge, level and plumb, and separate rule. If Unobtainable at Dealers Write Us Direct.

Send for Catalogue

THE LUFKIN RULE CO.

SAGINAW, MICH.
New York

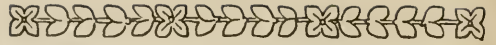

TRADE NOTES—(Continued)

The Experienced TEACHER

Of Mechanical Drawing Desires in the books for student use qualities of

**Thoroness
Simplicity
Ease of progress**

These requirements are all met in a most satisfactory manner in

MECHANICAL DRAWING PROBLEMS

BERG AND KRONQUIST

It also makes for progress by saving time. No long pages of text matter telling what to do—the students understand what to do almost at a glance. There can be no copy work—the problem must be solved by each student. It is progressive, easily so. It offers a wide variety of work not equalled by any other book on mechanical drawing. The technique is of the highest order and conforms thruout to the best practice. For the usual course offered beginners it provides two years of work in one volume, cloth bound, and sells for only \$1.28, with a discount in quantities.

A book of Key Plates showing the correct solution of each problem is available for teachers only. It is in blue print form, bound, and sells for \$2.80.

Other Text Books on Mechanical Drawing

Mechanical Drawing for Beginners
—BAILEY..... 68c

Grammar Grade Problems in Mechanical Drawing—BENNETT 44c

Problems in Mechanical Drawing
—BENNETT.....\$1.20

Mechanical Drafting—MILLER...\$2.00

Write for "Descriptive Catalog."

**The Manual Arts Press
PEORIA ILLINOIS**

City, N. J., displayed their standard equipment—the goods sold to commercial printers.

A new machine on display for the first time at this convention was a Universal Shaping Saw, a new tool of wonderful possibilities in the machine shop. It does the work easier, quicker and with far lower cost than it is done by the usual methods, and effects a great saving of material. It was demonstrated by Mr. Rasmussen and Mr. Ingalls of the Peerless Machine Company of Racine, Wisconsin.

An attractive display was that of the Western Iron Stores, Milwaukee, Wisconsin. It consisted of lathes, shapers, benches and other manual training equipment carried by this firm, and, while not a complete showing of their line, it indicated the ability of this firm to supply school machine shops with all requirements from line shafting to machines and hand tools. The display was in charge of C. F. Zimmerman.

Barnhart Brothers and Spindler displayed printing equipment and supplies featuring their new Superior Print-System Saw. This saw, a necessity in most commercial shops, is a decided convenience and aid in the school shop. If you do not have one

Hard-To-Get Materials

This is the Line you have been looking for

- Unusual Cabinet Hardware
- Chest Trimmings
- Upholstery Supplies
- Cushions
- Mirrors

Catalog to Instructors

**Thurston Manual Training Supply Co.
Jobbers and Manufacturers
ANOKA, MINNESOTA**

"JORGENSEN"

Peerless Hand Screws
are Adjustable

Think what that means in
widening their range of
usefulness.

Steel Spindles

Steel Nuts

Hard Maple Jaws

**Adjustable
Clamp Co.**

216 N. Jefferson St., Chicago

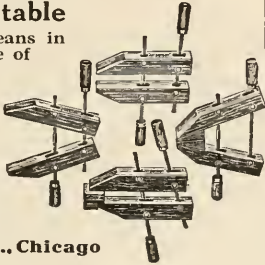

L-U-M-B-E-R

We Specialize in
Manual Training Lumber

No order is too large or too small to receive
our careful attention

John S. Benedict Lumber Co.
419 N. Halsted St. CHICAGO

MAYDOLE HAMMERS

THE WORLD'S STANDARD

Highest Quality Steel Handled Hammers
Guaranteed First-Class in Every Respect

*Booklet of Useful Information
for each student on request.*

The David Maydole Hammer Co.

Norwich, N. Y., U. S. A.



PUPILS SHOP ACCOUNTS

do Not Trouble Instructors Using Our Sys-
tems. Pupils do all the Recording
Accurately and "to date." All
Accounts are Kept

AUTOMATICALLY

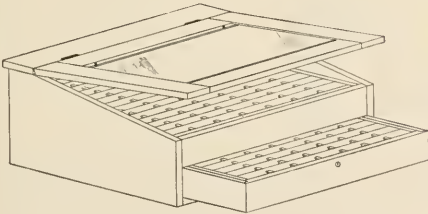

One of our Many Designs of the Industrial
Arts Record. Built to Handle Any
Number of Pupils.

Priced \$15 to \$85 with Liberal Discount
in Quantities.

Let your problem be our burden

MANUAL ARTS SPECIALTY CO.

ATCHISON, KANSAS

"Makers of Shop Efficiency"

SAW TABLES

For MANUAL TRAINING

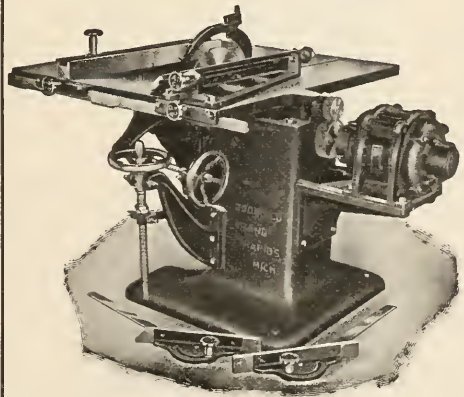

This cut shows our motor driven spiral
gear saw table. No countershaft, no belts.
Tilting or stationary tops. Write for cir-
cular and prices on our entire line. Address

ALEXANDER DODDS CO.

451-453 Monroe Ave., N.W.

GRAND RAPIDS, MICHIGAN, U. S. A.

Shop Problems

No. 8

Now Ready

"SHOP Problems" have been widely used for several years. Printed on tracing paper they can be easily reproduced as often as desired in the school shop. "Shop Problems," numbers 1 to 7, include a wide variety of successful projects in all materials, for all grades and in various subjects. Each Series contains 16 tracings. Series No. 8, just published, contains working drawings of 29 projects, all successful in school use. The projects in Series No. 8 include woodworking, sheet-metal, forging, furniture making, toys, etc. Read the list over; if you find only one or two of immediate use, the Series is worth purchasing at the low price of 35c.

CONTENTS OF SERIES NO. 8:

CAKE TURNER
 COOKIE CUTTER
 PICTURE STAND
 BISCUIT CUTTER
 DOUGHNUT CUTTER
 FLY TRAP
 DRINKING CUP
 MATCH BOX
 PAPER SPINDLE
 MINIATURE ANVIL
 ROCKING CLOWN
 MONOPLANE
 SURPRISE BOX
 LIBRARY LAMP
 HARDIE
 HAMMER
 SAFETY CHAIN CLEAT
 INVALID'S TRAY
 TUB STAND
 HOOK
 EYE BOLT
 CLEVIS
 SHELLAC CONTAINER
 TOY AIRPLANE
 SCOOTER
 TELEPHONE SHELF
 BOOK SEWING FRAME
 WASTE BASKET
 PORCH SWING

If you do not have Series Nos. 1 to 7, order them at the same time. They are uniform in size, etc., and sell at the same price, 35 cents per Series.

The Manual Arts' Press
 PEORIA, ILLINOIS

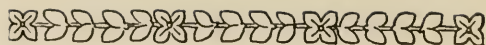

TRADE NOTES—(Continued)

in your shop write to this firm at their Chicago office and ask for complete information.

The Phillip Gross Hardware and Supply Company of Milwaukee had a full display of manual training shop equipment. It included standard makes of small machines, tools, etc. This firm is in position to supply your entire shop requirements of all kinds, including mechanical drawing instruments and supplies. They issue a catalog of 1,400 pages, describing and illustrating their various lines.

Other exhibits of special interest to the manual training instructor and supervisor were:

Oliver Machinery Company, Grand Rapids, Michigan.

American Wood Working Machinery Company, Rochester, N. Y.

Simonds Manufacturing Company, Fitchburg, Mass.

Henry Disston & Sons, Philadelphia, Penna.

Monarch Machine & Tool Company, Sidney, Ohio.

South Bend Lathe Works, South Bend, Indiana.

S. C. Johnson & Son, Racine, Wisconsin.

Wiese Laboratory Furniture Company, Manitowoc, Wis.

No More Loose Handles

Don't take chances with Hammers with ordinary Wedges when you can now secure the **UNCLE SAM BRAND** Hammers with the new **VAUGHAN'S EXPANSION WEDGE**.

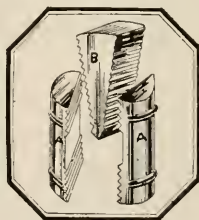

If the handle shows any tendency to become loose simply set the Wedge (B) a notch or two deeper between the pins (A) and a tight handle is assured.

UNCLE SAM HAMMERS are the only Hammers that have been approved by the **UNDERWRITERS' LABORATORIES** and each Hammer has the Underwriters' Label. It took 900 lbs. more pressure to pull the handle through the head with the **VAUGHAN'S EXPANSION WEDGE** than with the Ordinary Wedge. Uncle Sam Hammers are made in all patterns and sizes. Write for description booklet No. 10 which describes this line in detail.

VAUGHAN & BUSHNELL MFG. CO.

2114
 Carroll
 Ave.



Chicago,
 U. S. A.



BOOK NOTES

NOT long ago we asked Mr. Willoughby to tell us how he came to be interested in electricity, and, especially, how he came to write the book "Practical Electricity for Beginners" with so much of the boy-experience atmosphere about it. His reply interested us so much that we think it will interest others also. It explains, at least, in part, the origin of Mr. Willoughby's manner of presenting his subject:—

"Some years ago, when I was a young lad living on a farm and attending a country school I gradually became aware of the fact that it was about time for me to start thinking about learning something that would help me in following up some more or less definite line of work when I should be placed upon my own resources. What this was to be was far from being definite in my mind, and no one seemed to be able to give me any very definite information. I had lived in town when I was small but we had moved to the farm when I was ten years old. Therefore, I had practically no idea of the different kinds of work or the possibilities in the various lines. I had worked on a milk route and on farm, but felt that neither of these suited me.

"Upon completing the eighth grade and entering high school I had no idea of what I wanted to do. Altho I did not quite realize what benefit my training was going to be, I studied hard and learned my lessons well. I took what was called the Latin-scientific course which was entirely academic, since the manual training shop was so small that only a few could be taken care of in it. I was one of the unlucky ones but finally got some woodworking during my last year. I felt that I was not adapted to that work, however.

"Near the end of the course we studied physics and in the book was a rather limited section on magnetism and electricity. This seemed to me the most interesting of all of the work we had, and many of the other boys thought the same as I. The chief trouble seemed to be that the information given was more or less indefinite and the experiments we did were "too deep" and unfamiliar to us and the apparatus used in most cases was of a manufactured type and quite delicate. We did such experiments as the determining of the candle-power of a lamp, etc. Nevertheless, an interest was created and several of us decided to try to learn more about the subject than was given in school.

"I bought two dry cells, a bell and some wire, and took them out on the farm and spent most of my

spare time "tinkering" with them. I placed the bell up stairs where we boys slept and connected it so my father could call us by touching two wires together near the head of his bed. This was too much of a success for us so I tried other stunts such as making a telegraph out of the bell, connecting a clock in the circuit so it would cause the bell to ring at a given time, etc. Finally one of the boys made an induction coil (I don't know where he learned how) and invited me up to see it. I made one shortly after that and used the armature and circuit-breaker of the bell on it. It worked nicely and we boys had a great deal of fun with it. Later, I made a small motor which operated nicely and I devised a reversing arrangement, etc.

"Then I started collecting all of the printed matter available (very limited) and made many other simple devices, but most of these were of no practical value, and when the high school course was completed, I had learned no practical applications and was still at sea as to what to do. My progress in the school had been rather exceptional, so it was suggested by several that I go to college and take up engineering. I had come to believe that an education was a valuable asset, so entered college. I completed the four-year course given, and, by careful observation and by working in shops and for contractors during all of my spare time, learned all that I could about the various lines of engineering work, but the small start I had gotten in connection with the physics work in high school seemed to make that line of work most interesting and I have made a continual study of it since that time. (Fifteen years ago.)

"You will understand, then, that it has been with pleasure that I have started and developed electrical work for boys during the past several years, for I realize the desire that is created by a little touch of the work. In my book, I have tried to give points of interest which are also of practical value and directly applicable to everyday problems. Having completed the study of this book, the boy is in a position to actually earn money by applying what he has learned, and at the same time he has received a foundation upon which to build if he cares to go more deeply into the subject.

"*Practical Electricity for Beginners* furnishes information suitable for a boy in the upper grades, in high school, in continuation school, or in the home which is not only of interest but also of commercial value and directly applicable in the average life of today."

The best is none to good for the boys—

Specify **GREENLEE VISES**

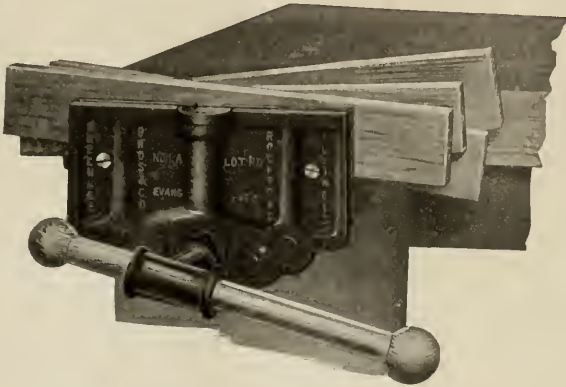

A Greenlee Cushion Grip Vise in action

BECAUSE
they have

Continuous screw action in both directions.

Free turning of the screw in either direction.

Quick action available at any handle position.

A screw not mutilated by long grooves.

A complete nut fully engaging the screw.

Simple, strong and positively connected parts.

Ask for descriptive booklet

GREENLEE BROS. & CO.

Rockford, Illinois



Over 1200 Schools
Use "Oliver" Tools



Woodworking Section, Industrial Shops, Farrel, (Pa.) High School.

"Oliver" Woodworking Machinery

is especially desirable for industrial school or manual training shops.

It is high grade, well guarded, efficient, simple to operate.

OLIVER MACHINERY CO.

Grand Rapids, Mich., U. S. A.

MANUAL TRAINING MAGAZINE

EDITORS CHARLES A. BENNETT, Peoria, Illinois.

WILLIAM T. BAWDEN, Assistant to Commissioner of Education, Washington, D. C.

ASSOCIATE ARTHUR D. DEAN, Professor of Vocational Education, Teachers College, New York City.

EDITORS: FRANK M. LEAVITT, Associate Superintendent Public Schools, Pittsburgh, Pa.

WILLIAM E. ROBERTS, Supervisor of Manual Training, Public Schools, Cleveland, Ohio.

Business Manager: L. L. SIMPSON.

Published monthly by The Manual Arts Press, 237 N. Monroe St., Peoria, Illinois.

Subscription Price, \$1.50; Canada, \$1.80; Foreign, \$2.00. Single Copies, 25 cents; Foreign, 30 cents.

Subscriptions, remittances and manuscripts should be sent to THE MANUAL ARTS PRESS, Peoria, Illinois.

Special Industrial Art Number

CONTENTS

ART IN LABOR (with two photographs).....	<i>Henry W. Kent</i>	295
HOW A GREAT MUSEUM HELPS THE SCHOOLS IN TEACHING FURNITURE MATERIALS (with photograph).....	<i>Frank Hilton Madison</i>	301
SUGGESTIONS FROM OLD FLEMISH WOOD-CARVING (Illustrated).....	<i>Charles A. Bennett</i>	303
CORRELATION OF SHEET-METAL WORK AND ART (Illustrated).....	<i>Florence M. Guenther</i>	310
THE WORK OF ALFONSO IANNELLI (Illustrated).....	<i>Charles A. Bennett</i>	000
EDITORIAL REVIEW FOR THE MONTH.....		316
Training in Art Craftsmanship—To Educate Appreciators—To Educate Workers— Real Experience Essential—More Expert Craftsmen Needed.		
A POINT OF VIEW.....	<i>Arthur Dean</i>	321
WASHINGTON CORRESPONDENCE.....	<i>William T. Bawden</i>	323
Bureau of Education Conferences—Problems of Organization—Sound Principles of Organization.		
IN FOREIGN COUNTRIES.....		324
The Alliance of Art and Industry—Educating Public Taste—Testing Color Vision.		
PROJECTS, PROBLEMS AND NOTES.....		326
Ancient bread cupboards—Old furniture made new—A beautiful old chair—Birthday cake stand—Mirror frame—Mantel clock—Arm rocker—Coat hanger—Why lumber is steamed during kiln drying.		
CURRENT PUBLICATIONS.....		334
FIELD NOTES.....		IV
California Field Notes—Southeastern Items—From the Southwest—Around New York—From New Jersey—Western Arts Association—New Shop Building at Mar- inette, Wisconsin—Eastern Arts Association—Oldest Public Trade School—Meeting of Schenectady Journal Club—Oklahoma Manual Arts Instructors in Conference— Pioneer Machinery Manufacturer Dead—Items of Progress.		
TRADE NOTES.....		XXX
BOOK NOTES.....		XXXIX

This Magazine is kept for sale at McClurg's in Chicago, and Brentano's in New York.



FIELD NOTES

CALIFORNIA FIELD NOTES

INDUSTRIAL ARTS PROGRAM

About three years ago, one of the members of our State Board of Education, Mrs. Agnes Ray, feeling that more attention should be given to art instruction in our public schools, succeeded in getting the Board to approve the idea of securing a state supervisor for the work. At first it was intended to provide a special state supervisor of art, corresponding to the state supervisor of physical education, and to the proposed supervisor of trade and industrial education. But considerations of expense made it necessary for the State Board to conclude that a supervisor should be appointed who would give his attention both to the art instruction and the industrial training aspects of school work. Proposals for the creation of the additional state supervisor were presented to the State Legislature in the form of a bill, and the bill having passed, John C. Beswick was selected by the State Board for the position. Fortunate indeed was the State to have Mr. Beswick selected for the combined position, since he had had experience and training in both the industrial and the art fields, his marked ability in art having been primarily exhibited in the stagecraft courses which he carried on in Los Angeles previous to his becoming connected with the State Office.

It was not, however, until last year that Mr. Beswick was able to give much attention to the art aspect of his duties.

ART EXHIBITS HELD

Before doing any propaganda work, or making new proposals, he visited many establishments scattered over the state that are particularly interested in art as applied to industry. As a result of these visits and his discussions with the heads of such establishments, and with the secretaries of certain prominent commercial organizations, Mr. Beswick made as the initial step proposals for exhibits of objects of artistic worth, coming from manufacturing and commercial establishments, as compared to similar objects made in the public schools.

The first exhibit of this sort was held in Los Angeles. There a large hall was devoted to the exhibit, where at one end were shown the products of commercial institutions and at the other, the work of the schools. As the primary object of this exhibit was to stimulate interest in applied art in our schools and to enlist the active interest

of manufacturers and merchants concerned with house furnishings and art objects, the State Board of Education, thru its Commissioner of Vocational Education, issued special invitations to prominent educators in general administrative, in art supervisory, and in manual training supervisory positions, and to manufacturers and merchants. As a consequence of these invitations sent over the state the applied arts exhibit was most satisfactorily attended, not alone by people located near Los Angeles, but also by educators and commercially interested persons from all parts of the state.

Particular stress was laid by Mrs. Ray upon the desirability of having the presidents of the various Normal Schools attend the Los Angeles exhibit, it being her belief that thru them interest in art education could be stimulated in the teacher training centers of the state, and thus in turn, art would be given more attention thruout the state.

THE OAKLAND EXHIBIT

The Los Angeles exhibit was followed by an exhibit in Oakland. There Frank Cauch, Director of Boys' Vocational Work, was the chief organizer. This exhibit was primarily for the benefit of the schools and industries located in and about the San Francisco Bay region. Whereas in the south the exhibits of the commercial product were put in one part of the room and the school product in another, the exhibit in Oakland was so arranged that the manufacturing and commercial products were shown side by side with the school products, each in a separate booth. Thus, for example, the house furniture offered for sale by the local stores was exhibited in one booth, and in the next was the produce of a similar nature from the schools.

The exhibits both in Los Angeles and in Oakland, included office furniture, household furniture, kindergarten room toys, playground apparatus, art needlework, framed paintings, millinery, costumes, etc., and also the products of applied art possessed by foreigners, showing the art as applied to industry peculiar to their respective countries. It is now planned in this State to have a travelling art exhibit, which may be used in one place and then in another, to illustrate art as applied to commercial products. It is felt over the State that these exhibits have stimulated renewed interest in applied art, and it is the belief of many educators that such exhibits, held from time to time, will help to maintain this renewed interest. It is the belief of the business men who participated in the exhibit that the emphasis on applied art will not alone place

Starrett Thickness Gage No. 71

Made especially for the Automobile Mechanic

Contains six leaves particularly adapted for adjusting motor tappets. Also useful for gaging slots. The six leaves have, respectively, thicknesses of .0015, .002, .003, .004, .006, and .015. Auto drivers have been looking for this tool.

The combination affords scope for gaging dimensions ranging from .0015 to .031. A neat metal case protects the leaves from kinks, and any leaf may be easily replaced by removing the screw stud on which it is pivoted. An eyelet in the case permits the gage to be carried on a ring or hung from a hook. Extra leaves supplied on order.

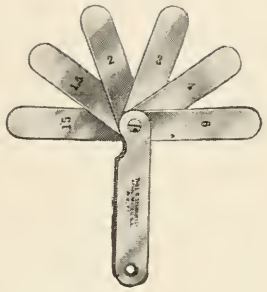

Full details of this new Starrett No. 71 Thickness Gage and other new Starrett Tools are given in Supplement to Starrett Catalog No. 22 "EF" completely illustrated. Write for copy.

THE L. S. STARRETT COMPANY

*The World's Greatest Toolmakers
Manufacturers of Hack Saws Unexcelled*

ATHOL, MASS.

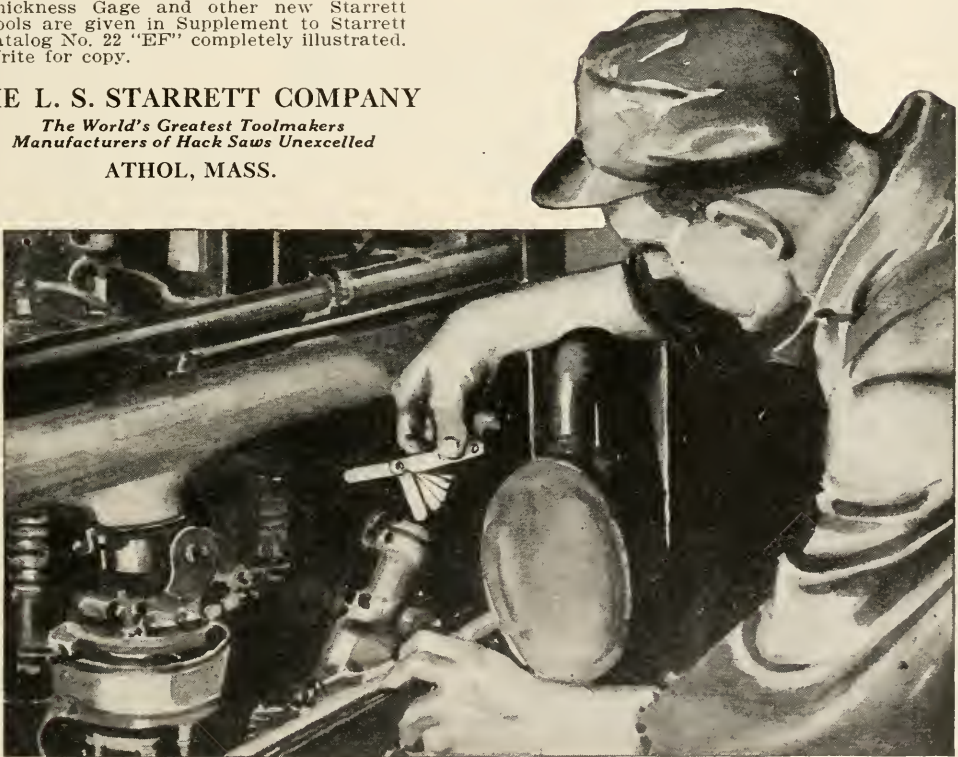

Use Starrett Tools



FIELD NOTES—(Continued)

due stress upon the importance of art in the work of manufacturing, but will also educate the purchasers to the importance of buying things of real artistic worth rather than shoddy products.

—CHAS. A. JACOBS.

SOUTHEASTERN ITEMS

PEOPLE living in the thickly settled centers have access to instruction in many lines of industrial or vocational work. Buildings, equipment, and instructors are available or easily obtained; but this is not true in the sparsely settled regions. The folks, scattered over the isolated coast, wide plains, or almost inaccessible mountains regions are out of range of the many good opportunities found in a densely populated region. They are hungering after opportunities that are being passed by out in the world.

A SCHOOL IN THE BLUE RIDGE MOUNTAINS

A fine example of work with mountain people is being conducted at Crossnore, an isolated mountain village of Avery County, North Carolina, and in the very heart of the Blue Ridge.

"In 1913 there was a little neglected mountain school at the crossing of two mountain roads, at the foot of beautiful hills in the narrow valley of the Linville River, one of nature's most picturesque spots. A spot, too, where the very sturdiest of this pure American stock had lived their simple life in rude cabins, tilled their rock hills and felled giant trees, filling other's coffers, themselves making scant progress towards acquiring the simplest comforts of life. Here in this dilapidated school house, closely resembling a blacksmith shop, the boys and girls of this splendid people got their only "schooling." Three to four months in the fall the school was taught by an older boy or girl, utterly unprepared to teach and incapable of taking the average pupil beyond the fifth grade. So at thirteen the young folks "quit school." The boys went out to work or to the West, but the girls' only outlook was matrimony, and they were carefully trained to feel that they were old maids at sixteen and hopelessly disgraced if not married by nineteen. One handsome, brown-eyed sixteen year old maiden said, "I see no peace at home, because I aint got a man and I'd rather be dead than single at twenty."

Things are different now—Crossnore waked up. Some one pointed the way, and with wonderful spirit for such isolated people, they put their shoulders to the wheel and pushed that little school up the hill. Three hundred children taught by college graduates, children who a few years ago had teachers who could not pass the sixth grade.

Sixty pupils—two of them married—who ten years ago had no hopes of getting beyond the fifth grade are now in an accredited high school. Two new school rooms replaced the old one; the next year a third one was added; the school term lengthened to nine months; two more rooms were added; a little industrial building was provided for manual training and domestic science. A big school house, modern in every respect, has just been finished—fourteen rooms, steam heat, drinking fountains, sewerage, electric lights and bells, and laboratory equipment. A new teacherage, and a model barn for the 75 acre farm are under way.

INDUSTRIAL ARTS WORK

The weaving department was established a little over one year ago. The weaving room has 12 hand looms, and 6 owned by the school are out in homes. The outside weavers received their first training in the school weaving room. The school furnishes the orders and material, gives instructions, and markets the product. This gives work to the mountain women, usually mothers who cannot be away from home, and have no other way to earn a little money. The work has a three-fold effect upon their lives. Their coming in contact with the teacher and the school changes their outlook and ideals; they find life very different when they handle a little money of their own, and the children feel a difference also; the beauty of the product, made under the guidance of trained teachers, creates a desire for better things in their own homes. The homes soon look better and become more attractive and comfortable.

At present, the yarns are purchased already spun, and sometimes dyed; but home made dyes, made from native materials, are used as much as possible. The equipment for dyeing is very primitive, and the work is done under the directions of an old woman, a native of the place; but some of the colors are very beautiful.

The looms are patterned after the old type, but made with more treddles and lighter material. All looms were made at the school. A new building is planned with space for 24 to 36 hand looms. The basement will contain machinery for cleaning, carding and spinning the wool produced by the community.

The amount earned by a weaver depends upon the speed and accuracy of the individual; even the poorest can earn 75 cents per day. The weaving room offers an opportunity for school girls to earn their school expenses. Under the careful direction of the superintendent, Mary M. Sloop, the department is self supporting.



*Academic, Art and Industrial Education
are combined in*
Printing

ENGLISH, spelling, punctuation, paragraphing, correct design, capitalization, harmonious color arrangements, color mixing, and technical processes always coordinate if Printing is used as an educational tool.

In North American schools and institutions, from coast to coast and from Canada to the Gulf of Mexico, instruction by means of Printing is making education a happy and interesting attainment.

Costs of installation, outfit and supplies are usually much lower than those of purely industrial subjects which do not coordinate with academic and art phases.

Teach with Printing

Write for literature, course of study and prices

F. K. PHILLIPS, *Manager*, EDUCATION DEPARTMENT

AMERICAN TYPE FOUNDERS COMPANY

300 COMMUNIPAW AVENUE

JERSEY CITY, NEW JERSEY



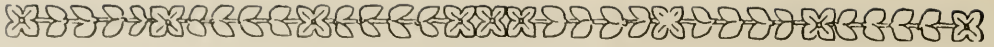

FIELD NOTES—(Continued)

Some of the products are rugs of various kinds, rag carpets, bed spreads (knotted or tufted in wool or cotton), curtains, table covers, towels, table linens, pillows, and dress goods. They are planning to produce woolen home-spun in the near future. "Our aim" at Crossnore is, "To keep alive an almost forgotten art; to cherish in the young people of the mountains a reverence for this art; to provide a means of livelihood and pleasure for women and girls; to furnish homes with beautiful and lasting material."

—FOREST T. SELBY.

FROM THE SOUTHWEST

INDUSTRIAL EDUCATION AT BISBEE, ARIZONA

Industrial education in Bisbee, Arizona, is being conducted along lines which seem to best fit the conditions as found in that section of the West. The courses have not only met with marked success but have produced splendid results, according to Prof. Boss, supervisor of industrial education.

In the school district that comes under his supervision there are three junior high schools, one large Mexican school and a well equipped senior high school.

The work in the junior high school consists of woodwork, concrete construction, sheet-metal, carpentry, applied wood-turning, electricity, and mechanical drawing.

The boy takes work in each one of the subjects mentioned, a record is made of his ability on a pre-vocational record card and this record is then filed with the supervisor.

A record card is provided in every subject and in this way, every boy's record is obtained in each line of work taken up. This record card is used when he enters high school and by it the supervisor is able to determine the line of vocational work best fitted to his needs.

In the Mexican school, cabinet work, sheet-metal, and concrete construction courses are given. These classes are more vocational than pre-vocational as the Mexican boys go to work at an early age and very few of them take the advanced high school work. The same "feeling out" process is used and record card showing the ability of the boy in the subject given, is made out and filed. This record can be used to show the boy's employer the line of work he has shown ability in, thus in many cases the Mexican boy takes up a trade which he likes and becomes a good man for the employer, and a better citizen. The Mexicans take a great interest in the vocational work and under a good instructor remarkable results are obtained.

The senior high school offers printing, including press work, linotype, and advertising. This work is conducted along commercial lines, all the printing for the district being handled by the students.

Woodworking, embracing carpentry, handling of power machinery in cabinet-making and joinery, wood-turning and pattern-making, is offered.

The machine course offers instruction in chipping and filing, operation of lathes, shaper, miller, drill press, grinders, power hack-saw, and planer.

Production of machine parts is covered in this machine shop, including the construction of a small metal lathe, power grinder, turning auto axles, spindles, and the making of tools.

Forge work is given in connection with each course, the practical as well as the theoretical work being followed. Basket-ball frames, center punches, cold chisels, hammers and many other tools are made for the schools thru this department.

The course in auto-mechanics embraces practical experience in construction, operation, and repairs of all makes of cars. The shop is equipped to handle from fifteen to twenty cars. These cars are owned by the schools, high school students, and members of the night school classes.

Scraping bearings, grinding of valves, fitting piston rings, timing valves, battery, coil and condenser testing, wiring up ignition system, disassembling and assembling high tension magnetos, study of clutches, "trouble shooting," and complete overhauling of machines are a few of the things taught in this department.

The drafting department is a most important factor in developing the curriculum. Here the actual study of machines and machine parts takes place. The operation, construction, and general assembly are worked out; drawings, tracings and blueprints are made; thus the boy becomes acquainted with the technical work of the machine, auto, woodworking, and forge shop before he starts the practical, work in them. All working drawings are made in the drafting room, blueprints run and the blue-prints used in each one of the courses.

As this class has had mechanical drawing in the junior high school they do not have to slight the preliminary work in order to do the practical, as geometrical construction, orthographic projection, isometric, oblique, cabinet perspective, and sketching have already been covered before the shop drawing is given.

APPLIED ART AT JOHN TARLETON AGRICULTURAL COLLEGE

Ever since Tarleton has been a state school it has offered a strong course in home economics for

Get Your Copy of This Book

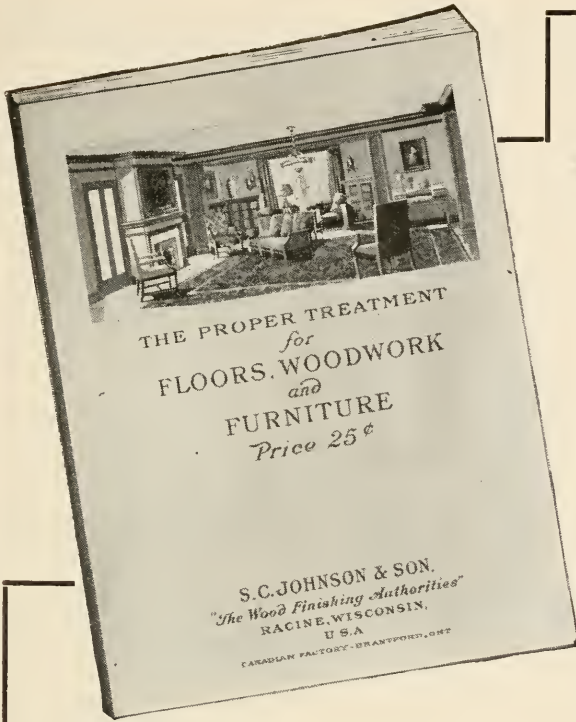

It's the best book ever published on Artistic Wood Finishing and should be in the hands of every Wood Finishing Instructor. It is full of valuable information on finishing all wood—soft and hard. Considerable space is devoted exclusively to the finishing of manual training models. It's the work of experts—illustrated in color.

How To Get It FREE

Write us (mentioning the name of the firm from whom you buy paints, varnishes, etc.,) and we will gladly send you our book "The Proper Treatment for Floors, Woodwork and Furniture" free and postpaid.

JOHNSON'S ARTISTIC WOOD FINISHES

Johnson's Artistic Wood Finishes are particularly adapted for manual training work as they may be applied by the youngest and most inexperienced pupils with good results. Johnson's Artistic Wood Finishes are standard for manual training—they are being used all over the United States and Canada for this purpose.

Our line of Artistic Wood Finishes is complete—it includes:

- | | |
|------------------------------------|---------------------------------------|
| <i>Johnson's Prepared Wax</i> | <i>Johnson's Perfectone Undercoat</i> |
| <i>Johnson's Wood Dye</i> | <i>Johnson's Perfectone Enamel</i> |
| <i>Johnson's Crack Filler</i> | <i>Johnson's Electric Solvo</i> |
| <i>Johnson's Paste Wood Filler</i> | <i>Johnson's Varnish</i> |

You will find this entire line described in our book. Any time specific information is desired, or whenever you want specially finished wood panels, do not hesitate to write us. We solicit correspondence with Manual Training Instructors.

Mail attached coupon for this authoritative book on Wood Finishing.

S. C. JOHNSON & SON, Dept. MT3, Racine, Wis.
"The Wood Finishing Authorities"
 Canadian Factory, Brantford

S. C. JOHNSON & SON

Racine, Wis., Dept. MT3.
 (Canadian Factory, Brantford)

Please send me free and postpaid your authoritative book on Artistic Wood Finishes for use in Manual Training Work.

The best dealer in paints here is.....

My Name

My Address.....

City and State.....



FIELD NOTES—(Continued)

girls. Three years ago applied art was added to the home economics. Since that time this work has been developed to such a point that it is one of the most interesting and popular courses offered for the women.

The course in applied art consists of three years' work. In the first year is offered a thoro course in the principles of art. The second year's work consists in applying to materials the designs worked out in the first year. Some of the processes used are stenciling, block printing, tying and dyeing, batik, enameling on wood, tin, and cloth, and embroidering (wool and silk). On each of these problems special attention is given to good design and harmony in color. Home decoration is the subject in the third year. In this course special consideration is given to the problems that come up in the selection, planning, furnishing, and the making of a home. A study is made of the history of furniture, relating it directly to the girls' needs, as well as ways of making the home more beautiful and liveable. Miss Mattie Walker is in charge of this work.

VOCATIONAL EDUCATION IN EL PASO

J. N. Hall, Director of Vocational Education in El Paso, reports two new classes in printing. Harry Blumenthol, the teacher, has organized a part-time class of apprentices and an evening class of tradesmen. Since September, 1921, this department has added considerable equipment so that it can render efficient service. They have added two up-to-date linotype machines and a cylinder press.

A class in dietetics for nurses has been organized as a part-time class. It is expected that some splendid results will come from this class. Arrangements have been made with a number of stores to put on some part-time classes in retail selling. Mr. Hall is now trying to get a well-qualified teacher to handle this work.

FIRST FOREMAN TRAINING CLASS IN TEXAS

H. M. Robinson, who is with the Northern Texas Traction Company, Fort Worth, has been doing a fine piece of foreman training work with the twenty-four foremen of that company. This is the first foreman training class so far held in Texas. The company officials are well pleased with the results.

—E. A. FUNKHOUSER.

AROUND NEW YORK

THE Board of Examiners of New York City Board of Education are anxious to secure competent teachers of drawing and applied art.

Teachers of drawing are appointed from eligible lists of persons who have passed the tests required by the Board of Examiners. Both men and women are eligible for the examinations.

The high schools employ over one hundred teachers of drawing, and there is at present a considerable number of vacancies. Candidates who receive good ratings upon the examination may expect early appointments to well-paid and permanent positions.

The examination is given on two successive days, and those successful in passing the written and drawing tests are later examined orally in a teaching test given before a class.

Candidates coming from a distance can arrange to have their oral tests given the day following the written examination.

The salary schedule for assistant teachers in high schools, run from \$1,900 to \$3,700 by annual increments of \$150.

The Board of Examiners is empowered to award credit on such schedules for outside teaching experience, and for experience in a professional occupation or in a trade in the cases of appointees to teach a subject related to such occupation or trade. The credit thus given entitles a teacher to a place on the schedule as tho he had served for the period so credited.

Appointments made from eligible lists are temporary, but may, at the close of the third year of continuous satisfactory service, be made permanent. An eligible list is valid for three years.

The art department of the Bushwick High School recently had an exhibition in the foyer of the main entrance. The work represents pencil outline drawings in large, attractive panels, and light and shade executed in pencil and pen and ink sketches.

The third-term work in color, showing color charts, original color schemes, and the matching of color in textile patterns is shown.

DR. HANEY ADDRESSES WOMENS' CLUB OF NEW YORK

Dr. James P. Haney, director of art in the New York high schools, recently delivered an address on the subject of "Art in High School" before the members of the Women's City Club at the Board of Education building. Art has made a great advance in the curriculum of the modern high school. A generation ago the subject of art was unknown in most high schools, and was admitted on sufferance only when it did appear. It was held to be a highly specialized subject, useful only to the pupil gifted with a talent for drawing. The present day curriculum demands art as a required subject of



SCHOOLS AND COLLEGES



THE STOUT INSTITUTE

Summer Session June 26—August 25, 1922

The following Courses are offered

VOCATIONAL EDUCATION—Courses, 7.

For Directors and Teachers of State and Federal Aided Vocational Schools. Degree and Diploma Credit.

Administrative Problems	Principles of Education	Citizenship for Vocational Schools
Org. of Home Economics	Principles of Teaching	Organization of Industrial Arts
	Teaching Vocational and Ind. Classes	

INDUSTRIAL ARTS—Courses, 33.

For teachers and supervisors of Industrial Arts and Manual Training in Elementary and Secondary Schools, Junior and Senior High Schools and for Vocational School Teachers.

Auto Mechanics I, II, and III	Electrical I	Machine Shop I, II, and III
Bricklaying and Concrete	Elements of Woodwork	Mill Work I
Cabinet Making I	Forging I, II, and III	Pattern Making I
Carpentry I	Foundry I	Printing I, II, and III
Drawing, Architectural I, II	Furniture Upholstery	Sheet Metal, I, II, and III
Drawing, Machine I, II	Grade and Prevocational Woodwork	Wood Finishing
Drawing, Mechanical, Elements of		Wood Turning I and II

HOUSEHOLD ARTS—Courses, 24.

For Teachers and Supervisors of Household Arts, for Dietitians and for Institutional Directors.

Cafeteria Management and Cookery	Costume Design	Interior Decoration
Clothing I, II, III, IV and V	Dietetics	Laundrying
Color and Design	Home Management	Millinery
Community Hygiene	Hygiene and Home Nursing	Nutrition
Cookery I, II, III, IV and V	Institutional Organization and Administration	Textiles

DEGREE AND DIPLOMA ACADEMIC WORK AND SCIENCE—Courses, 26.

For Stout two year course graduates and others studying for the Bachelor of Science degree in Industrial Arts or Household Arts and for those studying for the diploma.

Science

Chemistry, Food
 Chemistry, Food Analysis
 Chemistry, Industrial
 Chemistry, Physiological
 Chemistry, Textiles
 Materials of Construction
 Microbiology
 Physics, Household
 Qualitative Analysis

History

History, Modern

Sociology and Economics

Economics
 Home and Social Economics I, II, and III
 Sociology

Psychology and Education

Modern Industries
 Psychology II
 Psychology I (A) I (B)
 Psychology of Childhood

English

English Composition
 English Dir. Readings
 English Literature
 Public Speaking

Mathematics I and II.

PHYSICAL TRAINING—5 Courses

For Athletic Coaches and others interested in athletic games and swimming.

Basket ball coaching	Swimming for men	Swimming for women
Football coaching		Track and Field coaching

For catalog address

L. D. HARVEY, Pres.

THE STOUT INSTITUTE

Menomonie, Wisconsin

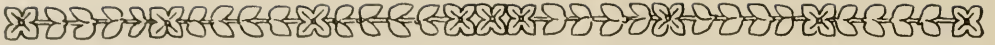

FIELD NOTES—(Continued)

every pupil and looks thru its teaching to see the standards of taste for the community advanced.

"In New York City, the high school art courses are framed to meet two distinct needs. The first is the need felt by the great majority of pupils who have but little talent, but who can be trained in taste. The second, and by far the smaller group, is composed of those who have decided skill of hand and eye and can be trained in technique.

"The first group the art department aims to help thru giving it a higher sense of appreciation, so that later on, as part of the great general public, it will patronize the work of the artists; that is, of the technically talented pupils who will become purveyors of art material to the community."

Dr. Haney referred to this division of the department's work as the training of "the many" and the training of "the few." "In the training of the many," he said, "the pupils are shown that the principles of art touch every individual, from the housewife who must decorate her home to the business man who must dress a shop window or arrange a newspaper advertisement.

"While the training of the many is general, the training of 'the few' is very highly specialized. 'The few' are those who are gifted with natural talent. They can be made into technicians; that is, into artists and skillful artisans.

"Dr. Haney told briefly of the 'Museum Days' arranged by the different high schools, when great groups of pupils numbering four to five hundred in all, visited the Metropolitan Museum or the Brooklyn Institute Museum, and also of the visits of the technical students to business studios where they were shown practical methods in which printing, lithography, and similar arts were carried out. He referred also to the conference plans of the department, whereby each month a meeting was held at which an exhibition of the best work done during the month was shown to all the art teachers of the high schools. These meetings were addressed by prominent artists, and the art teachers were thus kept closely in touch with the work of painters and sculptors in their studios."

—WM. H. DOOLEY.

LABOR UNIONS ASK FOR
MANUAL TRAINING HIGH SCHOOL

AT A MEETING of the Central Labor Union of Washington, D. C. on December 5, a resolution was made petitioning Congress for a new manual training high school for Washington. The need of additional facilities for education in tech-

nical arts was given as the reason for the request made. It was pointed out that the McKinley Manual Training High School is not adequate, either in size or equipment, for the present needs, that the cost that would be involved in rebuilding this school would be out of proportion to the gain which would be made, and that it would be more economical to build another school.

FROM NEW JERSEY

CLASSES were opened the first of the year for the most advanced group of apprentices of Electrical Union No. 52 at the Newark, New Jersey, Evening Vocational School. This provision for instruction adapted to Group A completes the system for apprentices, Groups D, C and B having been under instruction for some time.

The courses of study, as outlined by the local union, consists of instruction and experience with power equipment, such as A. C. and D. C. motors, generators and storage batteries, and auxiliary equipment such as compensators and transformers. The phase of trouble hunting will be considered and a thoro training given in underwriters rules, city and public service regulations relative to the installation of power equipment, various types of switches, meters, circuit breakers, armature coils, etc.

The regular program of the schools is carried on four nights each week. These apprentice courses are conducted Thursday and Friday evenings, leaving Monday and Tuesday evenings for either elementary drafting, or the elementary mathematics of direct current circuits.

SCHOOL CRAFTS CLUB MEETING

Saturday Evening, January 21 was Radiophone night for the members of the New York School Crafts Club. The meeting was held in Newark, New Jersey, and was an unusual one both from the standpoint of attendance and interest displayed. Several hundred men from New York and New Jersey were in attendance.

The meeting which was held at the Newark Technical School was preceded by an inspection of the sending station maintained by the Newark Westinghouse Co. and designated as W. J. Z.

"The Why and How of the Radiophone," was discussed by Rudolph Skrivaneck of the Elizabeth, New Jersey, Vocational School. Mr. Skrivaneck showed a splendid knowledge of his subject and enhanced his talk greatly by a display and demonstration of both commercial and school made instruments.

BOOKS FOR THE CRAFT WORKER

Stenciling—Mickel

Describes the technique of stenciling with water colors, oil colors, oil paints, dyes and crayon on linen, crash, poplin, Rajah silk, burlap, cardboard, unbleached cotton, etc. Many beautiful articles are shown. 85 cents.

Leather Work—Mickel

Gives detailed descriptions of the various processes of working, treating of flat modeling, embossing or repousse, carved leather and cut work. Well illustrated. Twenty useful and beautiful articles are shown. 75 cents.

Art Metalwork—Payne

Treats of the tools and equipments for the work and describes in detail, all the processes involved in making articles ranging from a watch fob to a silver loving-cup. The standard book on the subject. \$2.50.

Clay Work—Lester

A manual for teachers. It covers the study of natural forms, the human figure in relief and the round, animal forms, story illustration, architectural ornament, tiles, hand-built pottery, and pottery decoration. Richly illustrated. 70 cents.

Inexpensive Basketry—Marten

A teachers' manual, presenting in detail the processes of coiled basket construction. Treats of the necessary equipment, and the preparation of raw materials, and outlines a course for grades three to six. 45 cents.

Class Room Practice in Design—Haney

A concise, richly illustrated brochure on the teaching of applied design. 50 cents.

Educational Toys—Petersen

A comprehensive book on toy making for the school or home. Shows 57 toys. Tells how to make each toy, how to finish and color, about the few simple tools and materials required. \$1.80.

Furniture Upholstery—Johnson

Contains detailed, practical instruction telling how to upholster a variety of articles, also how to re-upholster old furniture and how to do spring-edge upholstery work. Describes necessary tools and materials. Abundantly illustrated. \$1.25.

Design and Construction in Wood—Noyes

A book full of charm and distinction. Gives due consideration to the esthetic side of wood-working. It is an aid in the designing of simple projects and articles of furniture. Gives information regarding tools and processes. A pleasing volume abundantly and beautifully illustrated. \$2.50.

Send for our 72 page
"Descriptive Catalog"

The Manual Arts Press

PEORIA - - - ILLINOIS

Schools and Colleges (Continued)

Bradley Institute

Summer Session 1922

First Term June 19 to July 21

Second Term July 24 to Aug. 26

Offers opportunity for study to teachers, supervisors and administrators of the Manual Arts, Industrial Education and Home Economics.

Courses in a wide variety of subjects will be available. Summer credits may be applied toward certificate, A. B. or B. S. Degree.

Send for preliminary announcement and detailed information.

Director Summer Session
Bradley Polytechnic Institute
Peoria, Illinois

University of Wisconsin

Department of Industrial Education
and Applied Arts

Summer Session, June 26-Aug. 4

Classes in Manual and Industrial Arts; Drawing and Painting, Commercial Art, Design, Art-crafts Work, Elementary Hand-work; Vocational and Industrial Education. Special attention to teaching methods. Courses leading to B. S. in Industrial Education or in Applied Arts. Graduate courses

Write for Summer Bulletin

DIRECTOR, UNIVERSITY
MADISON, WISCONSIN

TOOLS

For Manual Training Shops.
Send your inquiries to and get the especially low prices quoted by

MONTGOMERY & CO. Inc.,
105 Fulton Street
New York City



FIELD NOTES—(Continued)

Edwin F. Judd and John M. Dockstader discussed the radiophone as a grammar grade project and demonstrated by means of models what can be accomplished.

February 18, 1922 is the twentieth birthday of the Club and a banquet is being planned for this date.

PENNSYLVANIA SOCIETY FOR VOCATIONAL EDUCATION

The annual meeting and luncheon of the Pennsylvania Society for Vocational Education was held at Altoona, Pennsylvania, December 28, 1921.

Dr. W. G. Chambers presided at the luncheon. The speakers included J. C. Wright of the Federal Board for Vocational Education who spoke on "Vocational Education and Industry" and W. W. Evans, president of the Pennsylvania State Education Association, who took for his topic "Vocational Education for the Rural Districts."

PENNSYLVANIA STATE TEACHERS' ASSOCIATION

The Pennsylvania State Teachers' Association has announced the election of the following officers of the various departments as follows:

Department of Vocational Training and Practical Arts: President, A. S. Hurrell, Pittsburgh; Vice-President, Caroline M. Reddy, Reading; Secretary, Rodney Brace, Homestead.

Department of Continuation Schools: President, Lois Hoyer, Philadelphia; Vice-President, Millicent Leech, Pittsburgh; Secretary, Lillian Connell, Pittsburgh.

Department of Industrial Arts: President, W. M. Davidson, Pittsburgh; Vice-President, Lucy S. W. Wilson.

—ALLEN D. BACKUS

WESTERN ARTS ASSOCIATION
CONVENTION

TEN years ago, May 1912, The Western Arts Association held a most successful session in the city of Cincinnati. It will again be the honor of Cincinnati to have this convention as its guests on May 2, 3, 4, 5, 1922. Cincinnati is peculiarly attractive to the Western Arts Association in that she is a well known center of art, music, and industrial education. Her geographical situation is practically in the center of the territory from which the association's membership is drawn.

The convention and exhibition will be held in the Ohio Mechanics Institute, a building which covers one half a city block, very centrally located, and only a short distance from the hotel and business, and not to forget, the amusement center of

the city. Having the exhibitions and meetings in the same hall will avoid lots of walking and many errors as to direction. A splendid auditorium is at the disposal of the convention for its meetings, and all the class rooms, shops, and the gymnasium will house the exhibitions.

The best speakers that are available will be had for the occasion. There will not be only one good speaker, but an effort is being made to secure the best speaker obtainable for every discussion of importance.

The entertainment committee is hard at work on a program that will please any delegate of the convention. The hotel accommodations are so numerous that they need not be discussed. There is car service to every corner of the city, and plenty of it. All we are awaiting now is the coming of May and to see the record convention of the Western Arts Association for Cincinnati. Let's Go.

—WILLIAM CLUBER.

NEW SHOP BUILDING
AT MARINETTE, WISCONSIN

THE following interesting report has come from G. W. Schefelker, director of manual arts and vocational education Marinette, Wisconsin:

"A new manual training building of modern shop construction is being erected this year at Marinette, Wisconsin. The building is 90 ft. x 120 ft., construction of variegated art brick, tile and concrete, and when completed will be one of the most modern manual arts buildings in the state. Provisions have been made for a large machine shop and tool room, forge room, auto repair shop, three cabinet making rooms, mill room, carpentry shop, tin shop, finishing room, besides the main office, two well equipped recitation rooms and a number of storage rooms.

"The building is designed to take care of about 600 students. All inside walls will consist of large window sashes extending two thirds of the way down to the floor and in addition to this eight large sky lights have been provided thus admitting an exceptional amount of light into all of the shops. All partitions are so designed as to enlarge any of the shops in the future.

"The construction of the roof is such that it will serve as a floor for a second story, whenever it may be necessary to provide for more room. The building is a separate unit located between the junior and senior high schools thus preventing all noise or vibration of the shops from affecting either of the other two units. The structure is absolutely fire proof in every way."

LITTLE GIANT MANUAL TRAINING DEPARTMENT Special Equipment

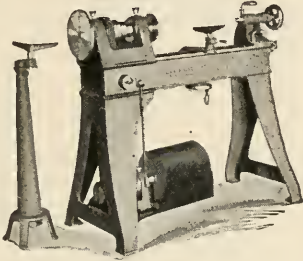

LITTLE GIANT WOOD LATHES

Individual Motor Driven, or Belt Driven from above or beneath.

Furnished with either Bench or Floor Legs. Wide choice of optional tools and equipment. Four speeds.

Many new, exclusive and practical features. All bearings are Hyatt High Duty Roller Bearings which greatly reduce power required. Ball Thrust bearings at all points of end thrust.

Sold on 30 days trial, and GUARANTEED FOREVER against defective material and workmanship.

LITTLE GIANT METAL LATHES

Individual Motor Driven, or Belt Driven from above or beneath.

Furnished with either Bench or Floor Legs. Wide choice of optional equipment. Three speeds.

Many new, exclusive and practical features are also found on our metal lathes. They are fitted to receive attachments for grinding, milling, gear cutting, etc., all of which we will furnish at a small fraction of the cost of a separate machine for such work.

Sold on 30 days trial and GUARANTEED FOREVER against defective material and workmanship.

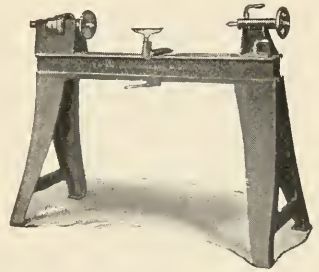

LITTLE GIANT POWER HAMMERS

Individual Motor Driven, or Belt Driven from above. Hundreds of different form-forging dies for instruction purposes.

Standard equipment with leading Technical and Manual Training Institutions.

Sold on 30 days trial, and GUARANTEED FOREVER against defective material and workmanship.



DO NOT OVERLOOK

Metal Working Equipment in your school. Wood can never be made anything else, while metal working and alloying are in their infancy.

The Industrial Leaders of the world, to a very large extent, began as metal workers.

Wood working is artistic, and trains mind, eye and hand to deftness. Metal working does all this, and more. It is also practical, and the graduate invariably finds a position waiting for him, while the wood working department graduate usually takes up something else and his instruction is forgotten.

Little Giant Equipment for Technical and Manual Training Schools consists of a full line of all metal and wood working machinery including accessories and tools for same.

On Motor Driven Equipment, information will be required as to Current, Voltage, Phase and Cycles of Motor.

Our business commenced in January, 1876, more than 45 years ago, and our Little Giant Products are used throughout the world. We are anxious to serve you for we can do it well.

Quotations and descriptive literature can be secured from any jobber, or direct from us.



LITTLE GIANT COMPANY

220 ROCK ST.

MANKATO, MINN., U. S. A.



EASTERN ARTS ASSOCIATION
—EACH AND ALL

THE Eastern Arts Association is to meet in Rochester, N. Y. April 6, 7, 8. This convention seems to promise the usual good things and some unusual features as well. It is not to be held on the Friday preceding Easter, but is to meet in the preceding week, April 6, 7, 8. This is going to give the members a chance to see the Rochester schools in operation. Rochester people declare that Rochester is the best home city in the United States, and we all know that Rochester is famous for its Junior High Schools. The only way to prove the Rochesterites' boast is to test it. The prediction is a record-breaking convention, good fellowship, and professional inspiration.

All exhibits will be centralized in the new Madison Junior High School Building; all general and sectional meetings, as well as all commercial, school, and members exhibits, under one roof. This is unique, in that Rochester is practically offering an E. A. A. club house. The subject of the meeting is "The Place of the Manual, Industrial, Household and Fine Arts in the Junior High School."

Schools, hotels, Chamber of Commerce, and musicians of Rochester are all co-operating in preparing the way for the Eastern Arts Association. Dr. William T. Bawden, Assistant Commissioner of Education, Washington, D. C. will open the convention with a conference. A few of the speakers are: Charles F. Binns, Director, N. Y. School of Clay Working; Arthur D. Dean, Teachers College, Columbia University; Alvin E. Dodd, Chamber of Commerce, Washington D. C.; Hugo B. Froehlich, Director of Manual Arts, Newark, N. J.; M. W. Haynes, United Typothetae of America, Chicago, Ill.; Frank Alva Parsons, President, N. Y. School of Fine and Applied Arts, New York, U. S. A., and Paris, France; William H. Varnum, Department of Applied Arts, University of Wisconsin.

—FRANCES H. BACHELER.

OLDEST PUBLIC TRADE SCHOOL

THE Evening School of Trades, Springfield, Massachusetts, is reported to be the oldest public trade school in America. It was established in 1898, and is thus functioning in its twenty-third year. During all these years this school has had for its aim the advancement of standards of workmanship in the various trades, and the individual efficiency of the working population which it has served

STANLEY

"Bailey" Planes



When properly used, Stanley Tools assure best results. Hence their value and established popularity in the educational field.

Stanley "Bailey" Plane No. 5 (shown above) has rosewood handle and knob, and the knob is of a special design for ease of handling. Frog is adjustable for width of throat opening after removing cap and cutter and slightly loosening screws which clamp frog to base. Smooth bottom. 14-inch jack. 2-inch cutter.

Hardware dealers sell Stanley Tools. Write for complete catalog.



The Stanley Rule & Level Plant

THE STANLEY WORKS

NEW BRITAIN, CONN.

New York Chicago
San Francisco Los Angeles
Seattle

Manufacturers of Wrought Hardware
and Carpenters' Tools

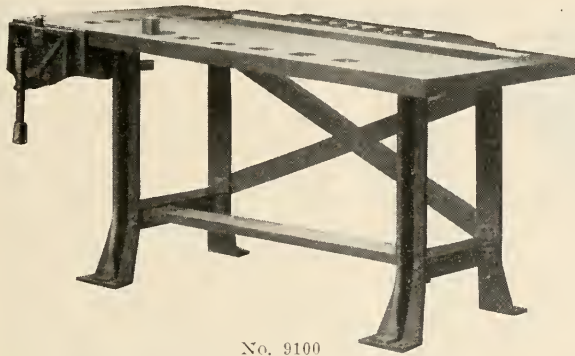

No. 9100

Built To Give Enduring Satisfaction—

Mr. Arthur Kinkade of the Board of Education of Decatur, Ill., writes of the laboratory equipment furnished by us for the new Roosevelt Junior High School:

"The cases, tables, desks and special pieces made by you are, in my judgment, very high quality, indeed. I believe I know cabinet work when I see it, having spent some ten years in the wood-working trade, and I want to say that you have an excellent product."

Consult us when you want standard or built-to-order manual training or laboratory equipment. Keep our catalog on file.

Wiese Laboratory Furniture Co.
ENGINEERS AND BUILDERS
 Factory: Manitowoc, Wisconsin

**WIESE
 LABORATORY
 FURNITURE**

Ask for our new Catalog No. 28

SALES OFFICES:

- 14 E. Jackson Blvd., Chicago, Ill.
- 806 Observatory Bldg., Des Moines, Ia.
- 514 Kemper Bldg., Kansas City, Mo.
- Louisville, Kentucky.
- Otterbein, Indiana.
- 121 Chartres St., New Orleans, La.
- 244 Third Street, Portland, Ore.
- 1610 Bryan St., Dallas, Tex.
- 101 Market St., Harrisburg, Pa.
- 24-26 First Street, S., Minneapolis, Minn.
- 166 Waverly Place, New York, N. Y.
- 310 East Bridge St., Streator, Ill.



High Grade Drawing Instruments

Largest Assortments
Highest Quality
Limited Quantity
100% Value: Order Now!

ASK FOR CATALOGUE

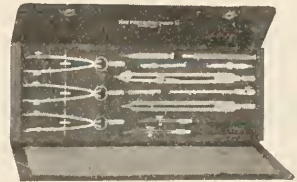

Set No. 55

This Special Set Your Opportunity, \$11.70 Postpaid

Complete Drawing Outfits from \$5.00 Up

THE FREDERICK POST CO.

MANUFACTURERS

319 So. Wabash Ave.

CHICAGO

3635 No. Hamlin Ave.



FIELD NOTES—(Continued)

This year there are 700 students enrolled in the evening classes. Eighteen teachers have been added to the staff of instructors. A course in textile design is offered for the first time. There is also a course in electrical engineering being organized. This course which will extend thru three years will be taught by men who have many years of experience in addition to their scholastic training. A great number of men and women who are unemployed have taken advantage of the slack season and are attending school to equip themselves better for the work in their vocation.

MEETING OF
SCHENECTADY JOURNAL CLUB

MORE than eighty persons, including educators from Oneonta, Troy, Albany, Gloversville, Glens Falls, Amsterdam and other nearby places, were in attendance at the December meeting of the Schenectady Journal Club, whose membership is made up of the male members of the teaching force of the Schenectady Public Schools. The club meets once a month, informally, to listen to a paper on some educational topic prepared by one of its members or some prominent educator outside of the city. A dinner precedes the talk.

Fred B. Reagle, assistant superintendent of schools of Montclair, N. J., and the present president of the Eastern Arts Association, addressed the meeting on this occasion.

He illustrated his talk with lantern slides showing the various types of industrial arts work, and other educational activities carried on in Montclair. He also placed on exhibition examples of pupils' work in clay, wood, cement, metal and reed. Of particular interest were the mechanical toys and different types of machines which had been designed and constructed entirely by the students. Mr. Reagle emphasized the importance and opportunity of co-ordinating practical work of this type with other subjects in the school program. Leon L. Winslow, specialist in art and industrial arts education, led the discussion. Mr. Reagle's talk was intensely interesting and everyone went away feeling that the evening had been well spent.

It is expected that similar gatherings will be held in the other cities of the capital district in the near future. They serve to get the teachers acquainted with each other, promote good fellowship and are helpful professionally.

—EUGENE D. FINK.



Yes—

**FRENCH AND SVENSEN'S
MECHANICAL DRAWING
FOR HIGH SCHOOLS**

(\$1.50)

is more widely used than any other book of its kind.

There's a reason—it's the best book of its kind.

Satisfy yourself—send for a copy on approval—test it out in your own classes.

That's what 600 other teachers did, and that's why the book is in use in 600 schools.

FREE EXAMINATION COUPON

McGraw-Hill Book Co., Inc.
370 Seventh Ave., New York

You may send me on 10 days' approval

FRENCH AND SVENSEN'S
MECHANICAL DRAWING
FOR HIGH SCHOOLS, \$1.50

I agree to pay for the book or return it, postpaid, within 10 days of receipt.

Signed

School

Official Position

Address

M.T.M. 3-1-22

Manual Training Magazine

MARCH, 1922

ART IN LABOR

A CHAPTER ON RESPONSIBILITIES IN OUR SOCIAL SYSTEM

HENRY W. KENT

Secretary, Metropolitan Museum of Art
New York City



ALTHO the following article was written nearly two years ago and presented at the tenth annual convention of The American Federation of Arts, it has not had as wide circulation as it deserves. For that reason, and because it strikes a note that we wish to accentuate, we give it the place of honor in this special number.

—THE EDITORS.

THERE is a certain element of the humorous in our discussing the possibility of introducing art into labor when the colleges and universities, ever regardful of young America, have kicked the oldest of the humanities out of doors. If, however, we believe that matters are ordered for the best in this world, we may nibble as on a crumb of comfort, the thought that while art is one of the humanities, it is a commodity as well. On that score, perhaps, the colleges and universities will admit it to their crowded schedules of study, along with journalism, automobile repairing, and other things. Some of us are prepared to argue the matter, but here, I may be permitted to assume the premises in the case, and to devote my time to a consideration of some of the factors responsible for art in labor.

Let us admit that art is a commodity when properly admixed with manufactures. The French have proved it. They have made it essential to their products. Indeed, they have achieved thru it a national style. Greece did the same, so did Rome, so did Italy once. It is not too much to hope that with

time we may attain to a general recognition of the value of style, and even achieve a national one. In what is called a melting pot, perhaps our many racial qualifications will get smelted into something resembling style. Heaven knows what it will be like, but it is safe to say that it will be something more than a Beaux Arts facade to a building, or a Louis XV room in household decoration. The responsibility for a national style lies upon no one pair of shoulders, but rests upon us all. No great nation has been without it. A manufacturing nation without it would not be above the machines that make her goods. National taste, then, is a national responsibility. Recognition of this fact would result in training. It is an axiom that to train a people requires that they should be taken in hand when young. This is just as true of training in a feeling for style, or art in manufacture, or whatever name you choose to give it, as in a feeling for economy or patriotism. There are sporadic attempts to teach this thing in the schools of some cities thru what in their schedules is called drawing and art, and history of art, but

these are not general and are not very seriously recognized or encouraged by the educational authorities or the Government. There cannot be a general sense of style as a necessity until the need for sound and conscientious teaching of the people when young is understood, and especially until the Government takes a part in the matter, requiring such teaching in all public schools and the establishment of art, trade and design schools maintained by the State.

Associated with this movement are the art, trade and design schools, already established, which independently have been grappling with the problem of supplying trained designers and craftsmen to labor. Their problems are peculiar, chiefly owing to the competition their students encounter in the products of the schools of other countries, especially those of France, thru the purchase by American manufacturers of foreign designs. Their opportunity to show whether their training was as thoro and the qualifications of their students as competent as their European rivals' came with the war, when the supply from abroad in large measure was shut off. It may be questioned whether what I believe to be the general practice of design schools in this country of teaching practical rendering without design are wise ones. But this is their responsibility and we may assume that it will receive attention since it affects their existence. Much has been made clear by the war which before was seen darkly. Theories may now be measured by more definite rules, such as will hereafter be laid down by those who are competent to express opinions, the manufacturers. Technical schools have an opportunity to play a part in manufactures and thru them in the national life never imagined as possible before. Perhaps the time may even come when the professional designer will

be recognized, a measure of honest generosity and justice seldom practiced in this country.

The test of the degree of style possessed by a people lies in what it makes and what it buys. The art sense in purchasing does not lie in what a few sophisticated collectors or its superfluously rich buy. The average home of the man with an average income tells the story. In that home today is found a greater degree of physical comfort—bath tubs, furnaces, electric lights—than ever obtained in the history of the world before, and a degree of aspiration after pleasant things, a striving indeed for "effect," "color schemes," "harmonies," and other things in phrases of the interior decorator and art schools. There is found, also, a seeking to put into practice the triturations taken from certain monthly publications with pages devoted to art in the shops. I am not meaning to under-rate the value of these agencies. They are good. They have done much to encourage a desire for taste in the house, and they have reached many people. Following the old rule for the giving of advice, "First find out what is wanted, and then give it," they have sought to give what they believe would be liked. But they can do better. A liking for pretty things does not constitute taste. Let them set a higher standard on the part of their contributors, especially with regard to the teaching of good and bad styles. A real responsibility is laid upon editor and contributor of such magazines, especially those who serve two masters, advertiser and reader.

I count the responsibility for art of the trade journals, those that serve the trades entirely, as one of the greatest in the country today. They exercise a power behind the throne of labor, and upon them depends to a degree unimagined by most laymen, the oppor-



FIREPLACE IN THE METROPOLITAN MUSEUM OF ART, NEW YORK.

tunity for the preaching of the theories of art in trade. Let them add to their staff people trained in this subject and competent to deal with it.

The present-day interest in objects of decorative art, dyes, and all the things that enter into personal and household furnishings, does not necessarily indicate

a growing intelligence in style or manufactures on the part of the large number of people whom we hear talking about them, but rather a personal interest in their own pocketbooks. European products having been shut off suddenly, people are wondering if the home-made substitutes will be as good as the foreign-

made. There has been magic in the familiar patter of the shop-keeper and the advertiser about "Parisian styles," "London fashions," French this and that, and English the other. Such talk is as old as our grandfathers and their colonial importations, reasonable enough then, when "shiploads just arrived from London" meant a real supply of what could not be obtained at home, but it is doubtful if statistics would not show that we are producing as much and as durable goods, in quantities sufficient to supply all our people, as any that ever came out of France and England. Part of our belief in the supremacy of overseas goods is due to a tradition one hundred and fifty years old, part to the thoughtful intention of manufacturers and shop-keepers alike to keep tradition alive, and part to a real excellence in a small percentage of our imports. A responsibility rests upon the buyer, you and me, to acquaint himself with the market, to learn what an enormous manufacturing people we are, to be intelligent in his demands, and justly critical in his estimates.

It is a fact not to be gainsaid that whatever has been in the past the preponderance of what is to be bought in this country, in the future will be home-made by American machinery.

Little bands of well-meaning people have been telling us ever since the advent of the machine in trade that only hand-made goods could be really excellent, that they alone had the divine afflatus. The monks told us this about printing when Gutenberg invaded their monasteries and took away the occupation of the scribes; we have been told the same things with the invention of almost every new machine. Doubtless there is a value in honest craftsmanship, perhaps even it surpasses the machine, but there is no reason why with the same

amount of brains it should. "Other days, other fashions." We are dealing with fashions for millions of people.

A few rich people furnish their houses with hand-made furniture, rugs, tapestries, drinking and eating vessels, made in Europe before the machine was thought of. Their treasures, following the rule laid down by Time himself, will eventually be bandied back and forth thru the auction rooms, serving a useful purpose as they go in public education in styles, until, eventually, they will find a place in the museum of the future as examples of by-gone arts and industries, models of the taste of their times. To these collectors this country owes a boundless debt of gratitude. Their possessions of documents of such value and such incalculable potentiality in the formation of taste and the modeling of style in our manufactures is among the foundation stones in the fabric we are rearing.

It is a good thing to collect admirable things, but it is a far greater thing to make them. This is the era of the machine. It is with machine-made things that the American of today, certainly of tomorrow, must content himself. The matter with which we are concerned is: Are the products of the machine to be good or bad? It is often debated as to whether improvement in the quality of art in American manufactures is to be the best and most quickly effected by the manufacturer himself or by the people. On the principle that a Government is just as good as the deserts of the people governed, so taste in manufactures is just as good as the taste of the people for whom the objects are made. The manufacturer makes his goods to sell. If their quality is such that they do sell, he is justified in believing that he gives what is wanted. As a matter of fact, the responsibility, however, for the artistic quality in most of our manufactures lies

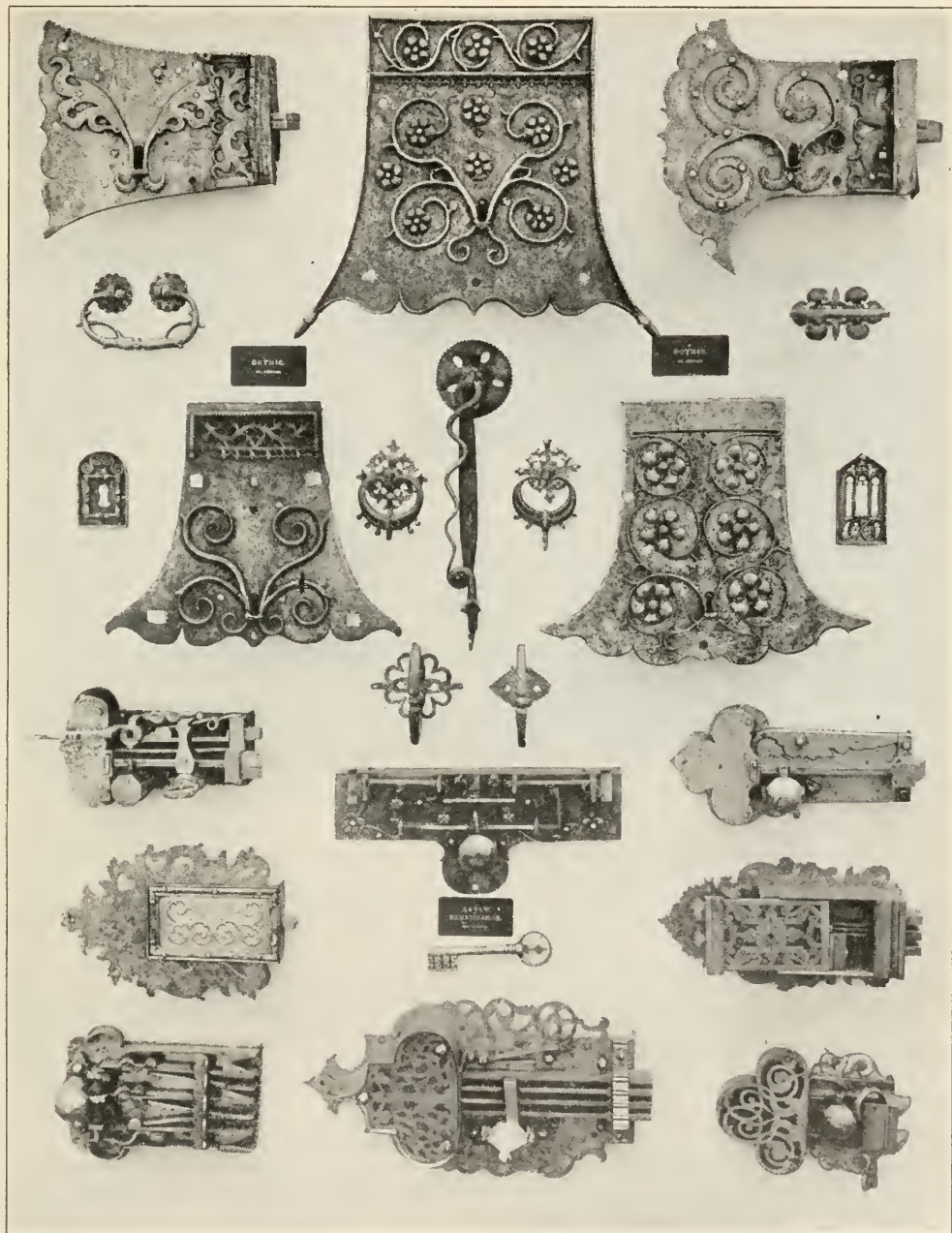

EXAMPLES OF MEDIEVAL METALWORK IN METROPOLITAN MUSEUM OF ART.

not with the maker, but with the middleman who buys the goods from the factory and sells to the consumer. He, it is who tells the maker of this and that what the people want. It is his business to gauge

the taste of the community and it is his risk that is involved. The manufacturer does as he is told.

If the average of taste, style, art, whatever name you choose to give it, in

American-made goods, is low, it is because the average buyer of them is uncritical. As I have said, there is an unusual degree of curiosity nowadays about matters of taste. But curiosity alone never accomplished much except bad manners. Something else is needed to lead people to learn to discriminate. First of all it should be generally understood what art is, that art is worth while, that good taste pays. If there be awakened in the country a sentiment in favor of this, there isn't much doubt but that the manufacturer and the middleman will each try to do his part in the improvement of his output. You can safely leave it to them to do whatever is necessary to that end.

Here is the question: Is the middleman competent to judge? His slogan of "giving the public what it wants," is all right if he is beneficent and all-seeing enough really to know. But there have been doubts expressed as to this omniscience. It is his responsibility to refute his critics. It is easily done, for by his goods ye shall know him.

It is gratifying to learn of movements to federate manufacturers, wholesalers and retailers, designers, interior decorators and publishers to improve public demand and appreciation for home furnishings.

Doubtless they will accomplish much. Their greatest field for accomplishment, however, lies in their power to awaken the Government to a sense of the importance of art in trade, as a national asset. It lies with them to persuade our Government to sponsor such efforts as those recently undertaken by Great Britain in the form of a British Institute of Industrial Art with provision for a permanent exhibition of British work, plans for bringing designers, manufacturers, and distributors together, a bureau of information to give foreign buyers knowledge of English industries, and in general

with the purpose of pushing art in British industries.

There is another element in the education of the people in art which should be mentioned, which is not the least in its responsibility—the public museum. The history of this institution shows it in the past to have been in a formative state to this end. For years its chief aim was the pleasure of the people and the convenience of privileged classes; then it espied its opportunity to help in the education of the people; and now it is coming to recognize the part it has to play in the labor of the people.

The power of its collections to give pleasure thru the transfusion of its objects is increased a hundred fold. The old theory that objects of art in museums were to be seen not touched is rapidly giving place to one of use. Visual instruction is good but tactile instruction is better. Demonstration is needed and the museum has seen the need. No single agency today except the Government has the power materially to aid art in labor to the extent that the museum has. As collector of styles, storehouse of design, demonstrator of taste, and in association with schools, it has a field great indeed.

Some may say, some do say, that this is not the province of art. Such believe that art, like the Lord, "moves in a mysterious way, his wonders to perform." It is doubtful if the Lord does. It is certain that art does not. Art should move in every way it can to help transform the world into a pleasant place to live in. And in this twentieth century it seems clear that one of its most important activities should be a closer alliance with labor. He would be an incurious man who would decline to do his part to bring about this end.

The responsibility for art in manufactures, then, lies upon us all. Every-

body's business is usually nobody's business, but in this case, there is a peculiar responsibility put upon a Federation of the Arts. It is ours to help bring about a national style, to help to set standards

in a public system of education, to encourage home products, and to adopt a broader understanding of them. It may be ours to see art a real power in the manufacturing of the country. Who knows?

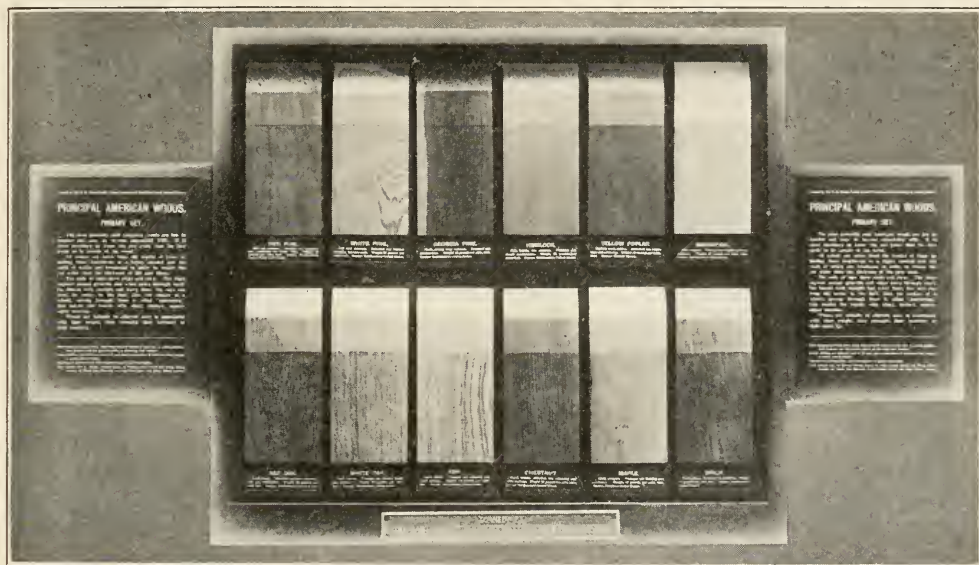

WOOD EXHIBIT SENT OUT FROM THE FIELD MUSEUM OF NATURAL HISTORY, CHICAGO.

HOW A GREAT MUSEUM HELPS THE SCHOOLS IN TEACHING FURNITURE MATERIALS

FRANK HILTON MADISON
Chicago, Illinois

COMING generations of Chicago school children are going to appreciate furniture. They are studying about the materials that go into furniture not merely from textbooks, but from actual specimens. In their classrooms they have exhibits of hard and soft woods, and are taught which of these go into cabinet making. From specimens showing the different raw materials and stages of production they learn how plate glass and mirrors are made, about the abrasives that are used in the wood-working industries, the fibers that are

used as substitutes for curled hair, how leathers are split and treated, about paints, pigments and varnishes and about metals. Their parents, too, learn something of these materials because they see the specimens at community-center gatherings in the school buildings. Inasmuch as other cities are about to adopt the same plan the coming makers, buyers and sellers of furniture will be better educated at the start.

This new and unusual educational work is done by the N. W. Harris Public School Extension of the Field Museum

of Natural History. It has hundreds and hundreds of interesting portable exhibits of economic and natural history specimens which are continually circulating thru the Chicago grammar and high schools and ex-soldiers' continuation schools. An exhibit remains three weeks in a school and is studied in connection with the class work in each room. Duplicate sets of each case make a wide circulation possible.

Modern museum men have realized the possibilities of educating the public, especially the children, about the materials used in everyday life. But unfortunately most persons visit museums in a holiday spirit, devoting most attention to the unique animals and beautiful birds. Altho school children are always admitted free, less than a tenth of the Chicago pupils visit the Field Museum each year. In an address before the National Educational Association, Dr. Frederick J. V. Skiff, director of Field Museum advocated the plan of traveling museums.

Ten years after that address the late N. W. Harris, a prominent Chicago banker made the plan possible by establishing a \$250,000 foundation for the Field Museum to be used for circulating portable exhibits of economic and natural history specimens thru the schools of Chicago. He had consulted leading teachers and sociologists and had become convinced that such a plan would lead children to remain longer in school and thereby become home-loving American citizens and of more worth to themselves and industry when they went to work.

"What would a boy or girl want to know about this?" was the guiding principle for Dr. S. C. Simms, curator of the N. W. Harris Public School Extension in working out this plan to make study attractive. Consequently there are to-the-point labels telling what it is, where it

comes from, how it is prepared and what it is used for—no Latin names of the family to which the specimen belongs.

Learning of the materials that go into furniture is a gradual process—woods come in botany, glass in geology and leather in zoology. Everything starts at the beginning—the raw product—and follows its interesting course to the users. These materials are shown in handsome glass-covered mahogany cases, 24" long, 21" high and of varying depth. Like the merchant's show windows, the "goods" are near the glass where they can be examined. These cases are displayed on special racks in the school-rooms, being transported to the schools in a motor truck with a specially designed body. Specimens are mounted on black-painted thin wooden tablets, usually 3 x 5 inches. Powdered materials are shown in glass-lidded box containers mounted like the wooden tablets. Each specimen is plainly labeled.

Among the hardwoods shown are gum, white oak, maple, chestnut, ash, red oak, birch, Georgia pine, Douglas fir, elm, cherry, and quartered oak. In soft woods there are mahogany, redwood, red cedar, spruce, red pine, cypress, yellow poplar, hemlock, quartered sycamore, basswood and walnut.

More information—but still brief and to the point—is given by large framed descriptive labels at each side of the cases. These labels slide into the cases when they are being transported. Such a label tells the pupil how to know the grain of the lumber, how the lumber is sawed and what "quartering" means.

These attractive cases serve well their prime purpose—to get children interested in the subject. From that point they go on with their teachers to further investigations. When you consider the tendency of the child to air its knowledge at home, real educational work about

the things that go into furniture is being done. The child who has learned something about woods and other materials is going to want a home in which he can use these things when he grows up—which is in a short time. Thus the object of better citizens and better American homes is obtained.

Other cities have taken definite steps to adopt the plan either in museums or schools. One of the government de-

partments shows signs of applying the portable exhibit idea to its extension work. Madame Maria Montessori, the noted authority on child training calls it "a most desirable contribution to school work and education generally." With such cities as Brooklyn, Philadelphia, Pittsburgh, St. Louis, Milwaukee, Cleveland and Los Angeles having shown active interest, its wide-spread adoption is likely.

SUGGESTIONS FROM OLD FLEMISH WOOD-CARVING

CHARLES A. BENNETT

FOR many years it has seemed to me that more teachers would encourage their students to use wood-carving as a means of decorating woodworking projects if they themselves were aware of the possibilities in adapting some of the earlier forms of carving to present-day needs. If the teachers were aware of the ease with which excellent decorative results can be obtained with simple carving, and to what extent the skill required to do such carving is identical with what is taught in most joinery and cabinet-making courses, they could hardly do otherwise than to have beauty spots of carving added to the projects that are taken home by the children. The teachers well know that these visible evidences of skill are going to be kept for years and that the more beautiful they are thought to be the more they will be cherished. In fact, any thoughtful teacher knows that he is in a position to mold the tastes of the people in the homes of the community in which he teaches thru the quality of design and decoration and finish of the projects that he allows to go from his school to the homes of his students.

Among the earlier forms of carving the Flemish of the fourteenth and fif-

teenth centuries is very rich in possibilities. This is especially true of designs developed from Gothic tracery because they fit school conditions so well. In the first place, they are, for the most part, geometric in character, and therefore readily comprehended by students of mechanical drawing. Secondly, the carving consists almost entirely of "grounding out" and carving mouldings. Beyond the making of these mouldings there is hardly any modeling, and, with few exceptions, that is produced by simple cuts. Moreover, no great accuracy is required to produce very pleasing effects. It is a fact that as one studies the carvings of this period as he finds them in the churches and museums of Europe and a few of the museums of this country, he becomes aware of the fact that many of these celebrated examples of carving were not accurately cut except in one particular. The workmen did keep the main lines of the design quite perfect, but the secondary lines and minor details of form were no more accurately done than many a seventh-grade boy could do them. Perhaps, the secret of the charm of many of these old pieces is in the combination of rigid accuracy in the main lines with the free cutting of

the minor parts—freedom, but within the confines of rigid law. This fact suggests to the teacher the most vital element in his teaching of this type of carving: Be sure that the main lines,

we of this generation have found more mechanical means of expressing intricacy and mystery, but we should remember that stamped metal or “composition” ornament, for example, ground out of a



FIG. 1.

which are nearly always geometric, are cut accurately.

Because I believe that most teachers of woodworking look upon such a design as Fig. 1,¹ as being something very intricate and more or less mysterious, I am writing this article, giving the key to the analysis of such designs and suggesting a few of the many possible applications of the elements of such designs to modern shop projects. It is true that

¹The historic examples of wood-carving shown in this article are in the Museum of Fine Arts, Boston.



FIG. 2.

machine by the yard, is not used because it is better than carved wood, but merely because it is cheaper. For this very reason, there is left to the teachers of shopwork the opportunity of holding up a high standard of artistic expression thru carving.

Turning now to the plate of drawings, Fig. 3, in *B*, is shown the main lines of one of the upper panels of Fig. 2. It

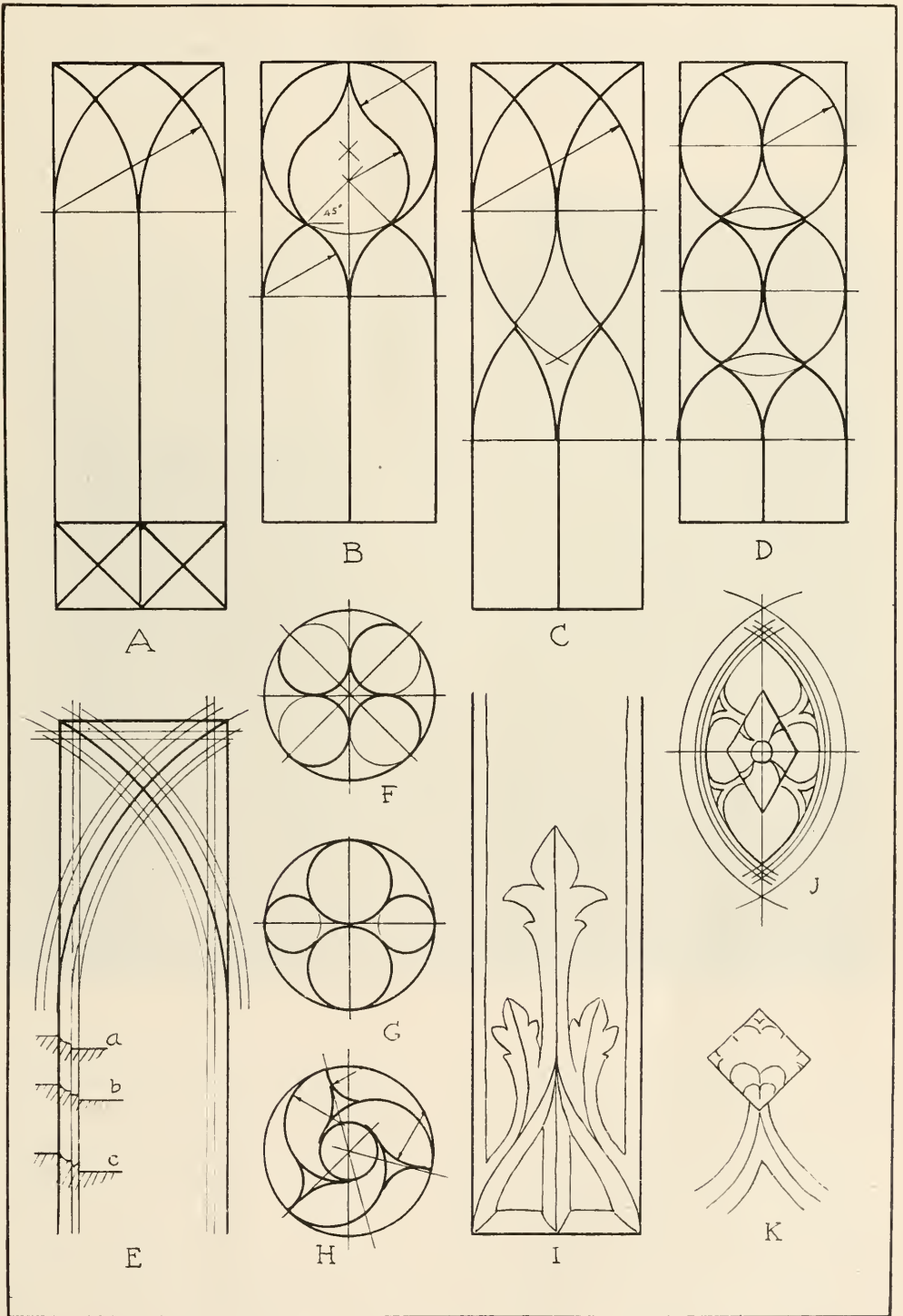

FIG. 3.

should be noticed that these lines are drawn with the compass; the pattern is geometric. These main lines are the high lines of the design; they represent all that is left of the original surface of

shown at *b* is sometimes used, and section *a* may be used in simple applications of tracery forms to good advantage. *C*, Fig. 3, gives a partial analysis of the design shown in Fig. 1, except that the proportions in Fig. 1 are more subtle and the curves are all or nearly all drawn freehand. For these reasons, the design in Fig. 1 is more permanently satisfying than many of the other designs shown in the illustrations of this article. This fact, then, furnishes another suggestion to the teacher: When pupils have suf-

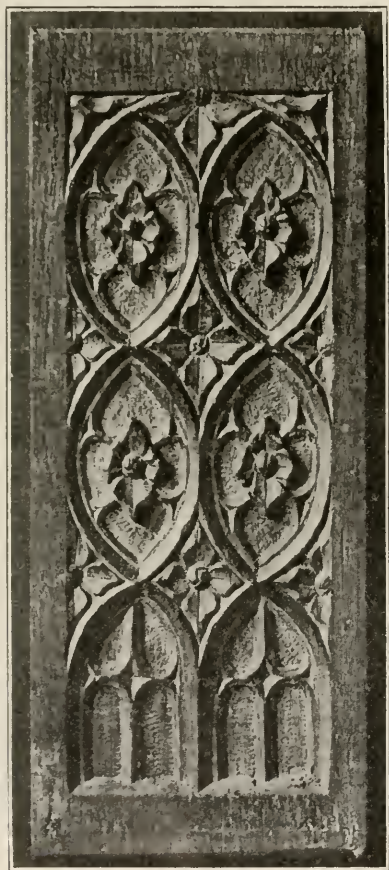

FIG. 4.

the board into which the design is cut. *A*, Fig. 3, represents the main lines of a simpler pattern which is similar to the lower part of *B*.

In order to understand how these patterns are cut, see the detail of the upper part of one side of *A* shown in *E* with lines drawn to indicate the cutting. The section at *c* suggests the common form of the moulding in the Flemish examples shown in this article. The section



FIG. 5.

ficient appreciation of proportion and curvature and enough skill to depart intelligently from the mechanically drawn lines, the results will be more pleasing to the trained eye, and may, therefore, represent a higher form of art, if the main lines are drawn freehand. But I hasten to add that with a very large majority of students as we find them in the manual training and applied art classes, it is better to confine our efforts to getting

results with the mechanically drawn main lines and use the freehand lines only in the drawing of the minor details that do not suffer so much when poorly drawn. Turning again to the plate, Fig. 3, *D* is an analysis of the character-full

circle in Fig. 6 is merely a square modeled with comparatively simple cuts of the carver's gouge. *I* is an unusual variation shown in the lower part of the middle panel in Fig. 8. It is perhaps out of harmony with the best tracery ornament,



FIG. 6.

FIG. 7.

design shown in Fig. 4. On the same plate *J* shows how the moulding lines, the cusps and the rosette may be drawn. In this case, as will be seen, the rosette consists of two equilateral triangles, base to base. The cusps in this case are drawn freehand.

F, Fig. 3, shows the main lines of the top part of Fig. 5; *G* is from Fig. 6 and *H* from Fig. 7. *K* makes it clear that the foliated ornament above the large

but suggests good possibilities to the designer of the present day.

As the purpose of this article is to offer suggestions rather than to give working drawings, and as the important suggestion has been given in calling attention to the analysis of Gothic tracery designs for carving, there remains only to give proof that the first suggestions are practical. Figs. 9 and 11 show book ends designed and made several years



FIG. 8.

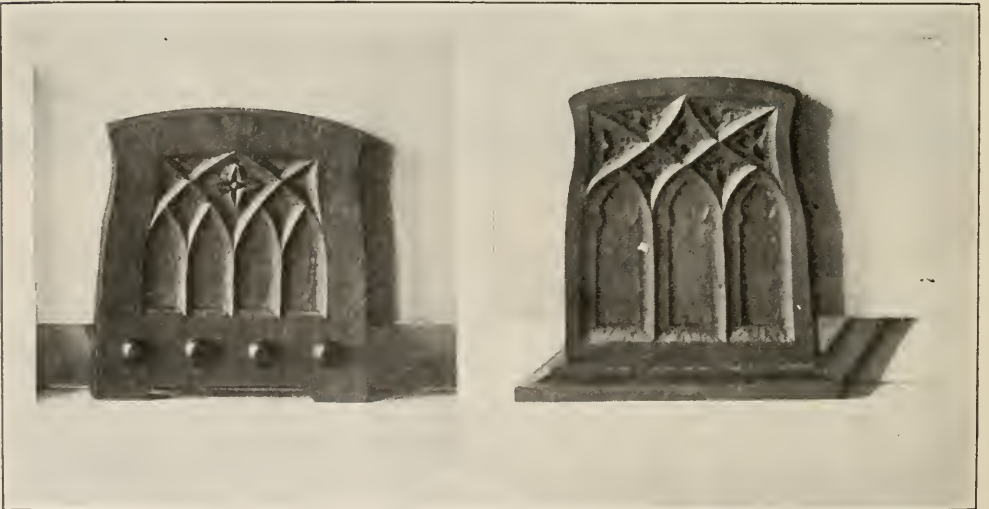

FIG. 9.

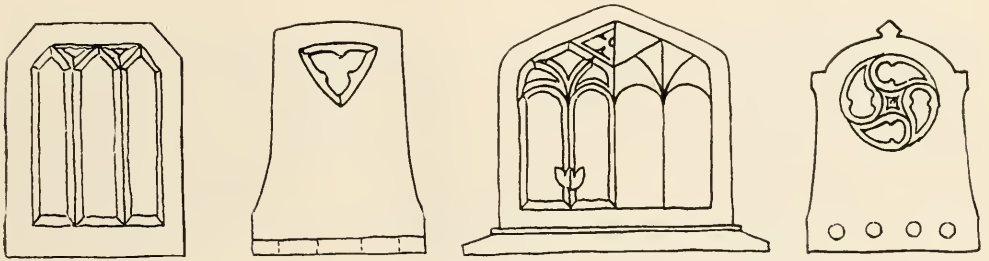

FIG. 10.

ago by normal students at Bradley Institute. The rough sketches in Fig. 10 show other possibilities. Fig. 12 indicates how spots of tracery ornament may be applied to a table and a pedestal. Many other suggestions for application to chests, desks, taborets, tables, boxes, chairs, etc., might be given.

Further details concerning the designs and the carving are given in Chapter VI of *Woodwork for Secondary Schools* by Griffith. Some of the attractive possibilities of perforated tracery designs are suggested by the example from the South Kensington Museum shown on the cover page. This suggestion is worth following out where a perforated design is appropriate, because with a jig-saw, and sometimes with a coping-saw, it is possible to make the perforations quicker than the "grounding out" can be done, and if the main lines of the design are broadened into bands, as in case of the example on the cover page, the strength of the article may not be impaired.

If anyone objects to this style of ornament on the ground that it is ecclesiastical and institutional, it can be pointed out that, while this is true in the United

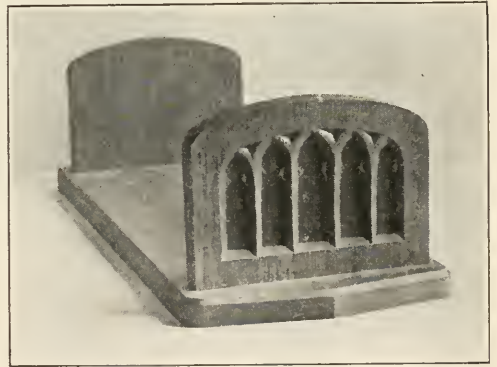

FIG. 11.

States, it is less true in Europe, and we do know that the Gothic is a popular style for school buildings in this country. But the claim for this form of carving is not based on the popularity of Gothic architecture for certain types of buildings, but on the fact that it is an appropriate

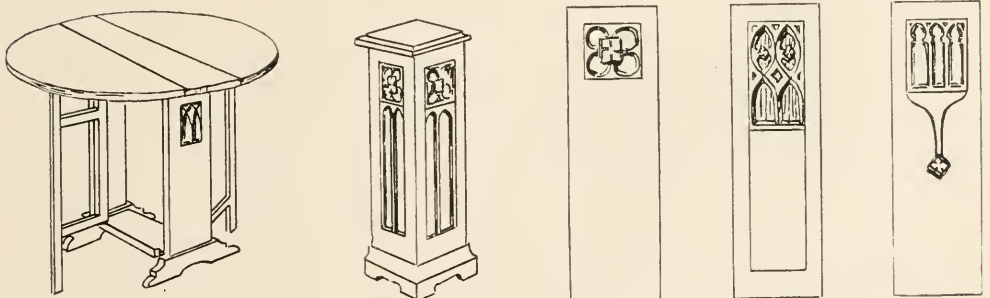

FIG. 12.

means of decorating wood, and that skill required in this type of carving overlaps to a considerable degree the skill required in the usual chisel work in school shops. The great practical difficulty in teaching many types of carving in the manual training shop is that they involve so much time in execution that their value

is questioned, except in the case of a very few advanced students who have a definite bent toward sculpture. The tracery provides a form of carving that was not invented by sculptors, but grew logically and naturally out of the work of the joiners and cabinet makers of the Middle Ages.



CORRELATION OF SHEET-METAL WORK AND ART¹

FLORENCE M. GUENTHER,
Seward Junior High School, Minneapolis, Minn.

DESIGN in connection with sheet-metal work at Seward Junior High School, Minneapolis, is carried on in the art classes. Most of the structural design is embodied in the patterns given the boys by the sheet-metal instructor. A knowledge of that phase of design is obtained, however, in the art classes thru abstract study and not always necessarily thru a specific problem.

This is largely due to the fact that art classes meet in academic rather than in industrial groupings. Therefore it is

deemed wisest to present art work in a more general way, with the cultural purpose in mind; always, however, calling attention to particular application, whenever possible.

So the decorative design is planned for definite projects worked out in the sheet-metal shop. This design, then, is worked out by a whole group, while its application may be carried out by only a few members of that group, and some of another. Designs are planned first, usually in pencil, sometimes with crayon or colored paper. Sometimes the same design is worked out in several different color schemes. All designs, when finished, are sent to the shop for application.

¹ This article is supplementary to the article on "Sheet-metal Work for Junior High Schools, by Charles Aberg, which appeared in the January number of this Magazine.

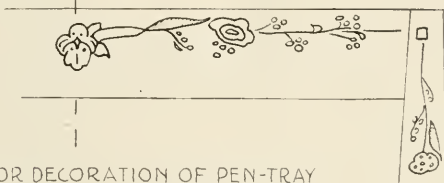
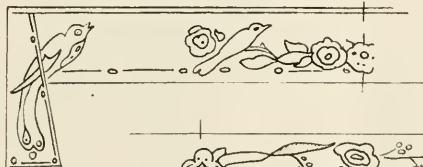

DESIGNS FOR DECORATION OF PEN-TRAY

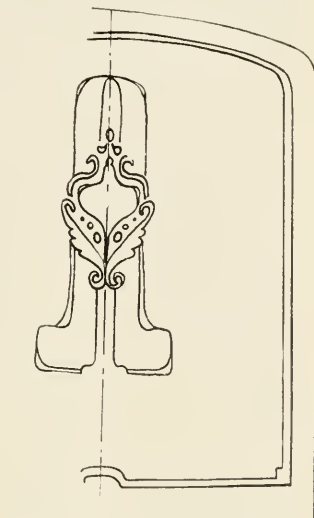

DESIGN FOR BOOK ENDS

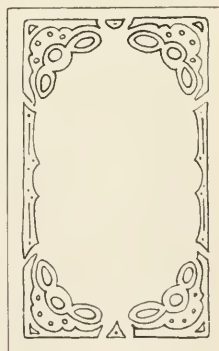
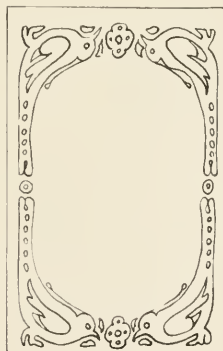
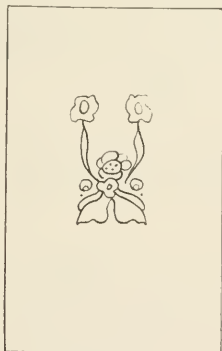
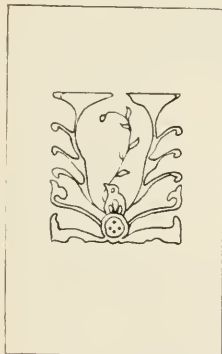

DESIGNS FOR DECORATION OF MATCH-BOX

You may say that a man cannot learn or teach a sense of art as he can learn or teach Greek grammar. That only means that a sense of art is often more difficult to acquire; it does not mean that no effort should be made to acquire it. Anyone who has the desire to do so can work as hard in training his sense of beauty as in acquiring any kind of knowledge; and such training is difficult for us now mainly because we have so long neglected it that we do not know how to set about it.

—THE LONDON TIMES.

THE WORK OF ALFONSO IANNELLI

CHARLES A. BENNETT

IN accordance with my usual custom I spent an hour at the Art Institute the last time I went to Chicago. I was fortunate in being there when the works of Alfonso Iannelli were shown in one of the galleries. This exhibit consisted of casts of sculpture and quite a variety of designs which had been worked out in other materials. I was particularly attracted by a group of photographs showing interior views of a home. First, I was struck with the daring originality of the whole scheme of furnishing, then with the beauty in certain elements of it, and, especially, with the unique character of the furniture. I saw that Mr. Iannelli had used ply-wood in a way to produce results quite out of the usual, yet in harmony with the character of ply-wood itself.

From nobody knows when the cabinet-makers have been limited in their designs by the fact that wood has grain and that it shrinks and swells more across the grain than lengthwise, but here is a designer of furniture who frankly ignores the fact that wood has grain by using ply-wood which shrinks no more one way than the other. He treats wood as though it were metal or paper. And why not, if it be ply-wood? He takes a wide piece and binds it with a narrow strip of thicker wood to finish its edges and give added strength. But this is not all, for he has hit upon the happy idea of using perforations as a means of decoration. He cannot carve ply-wood; inlaying would be difficult; but perforating is most appropriate. Figs. 1 and 2 are two of the photographs that attracted my attention.

Thru the Institute office I made telephone connection with Mr. Iannelli and was invited to visit his studio at Park Ridge. I went out there immediately

and felt well repaid for the trip. Mr. Iannelli is an Italian by birth, tho' thoroly American in sentiment. He is thirty-four years old and just coming into public attention. The display at the Art Institute was his first exhibit, yet he has been designing and making things for a long time. He has worked in several materials; he is a sculptor, metal-worker, commercial designer and architect. Much of his education has been in craft work. He believes that a considerable part of an architect's training should be in shops where he can learn the practical use of various materials. He believes that a designer must know the materials in which his designs are to be worked out. The fact that this is often not true accounts for much poor design as well as some of the slowness of progress toward a distinctively American art. Mr. Iannelli is willing to depart from precedent if he has what he thinks is a good reason for doing so; he dares to ignore the rules of the builders of Europe. The creed of Mr. Iannelli and the group of young craftsmen he has drawn about him is:

We believe that to be truly beautiful an object must have a place in the world and a meaning in human life. It must be conscientiously wrought within the limits of the material at hand to be as harmonious and as fit as the designer can make it.

We believe in original work, untouched by imitation of the art of Europe or of the ancients,—in American art for Americans.

We believe in simplicity, in the elimination of all senseless forms, in an alert, keen, and questioning mind that accepts nothing because it is customary, that abhors all compromise, that applies to everything the acid test of fitness. Amen.

In conversation with Mr. Iannelli I learned that an important part of his work is to take the interior of a room which some other architect may have built and completely equip it with fur-

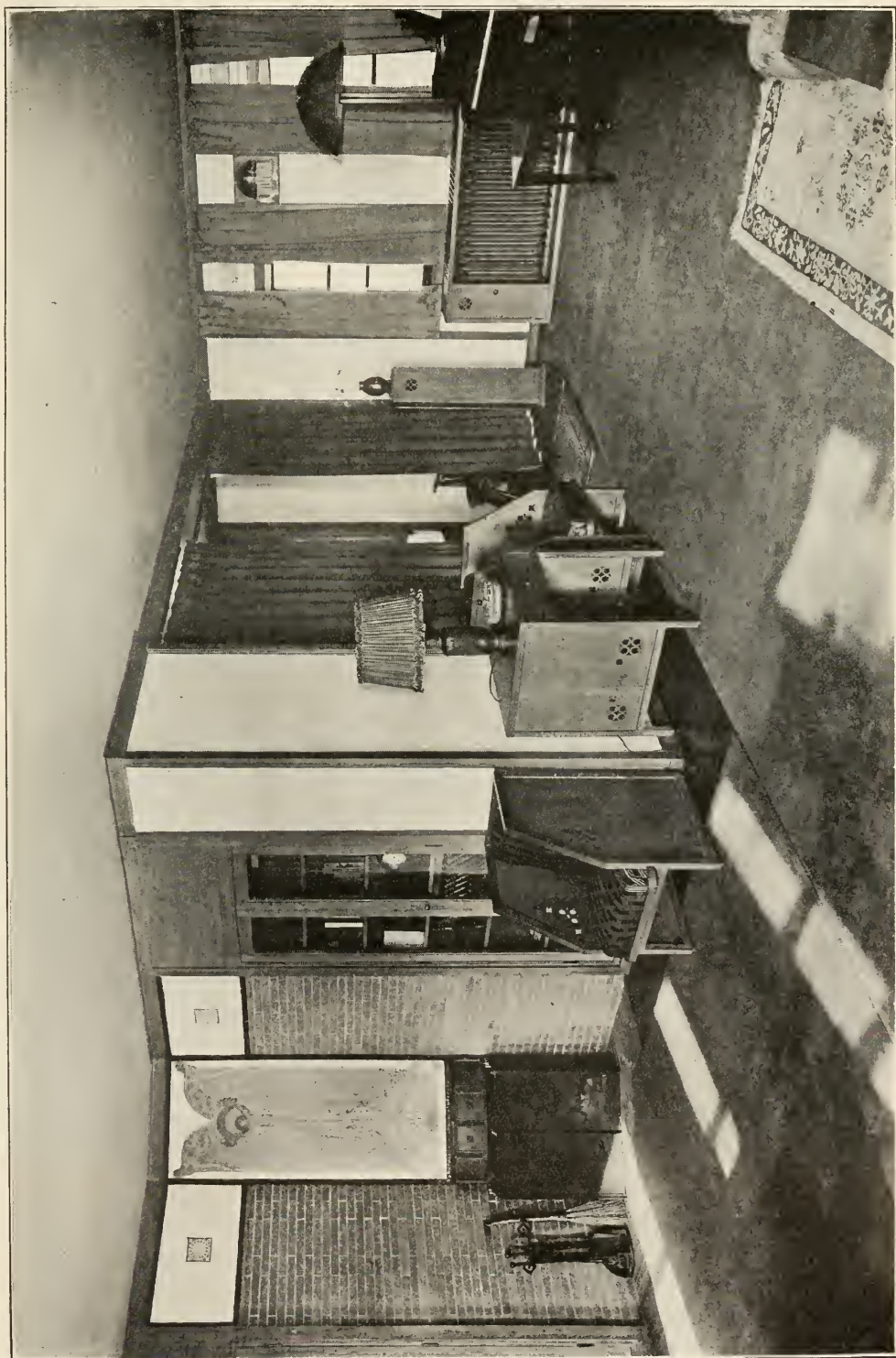

FIG. 1. INTERIOR DESIGNED BY ALFONSO IANNELLI



FIG. 2. DINING ROOM DESIGNED BY ALFONSO IANNELLI.

nishings of his own selection and often of his own design. For example, the rug shown in Fig. 1 was designed by him and then manufactured especially for that particular home. The same is true of the furniture and the various decorative

features of the room. The color scheme of the room and the reflected lights are thoroly studied.

Some of his most beautiful work is in metal. One of his pieces of church silverware has been described as "gorge-

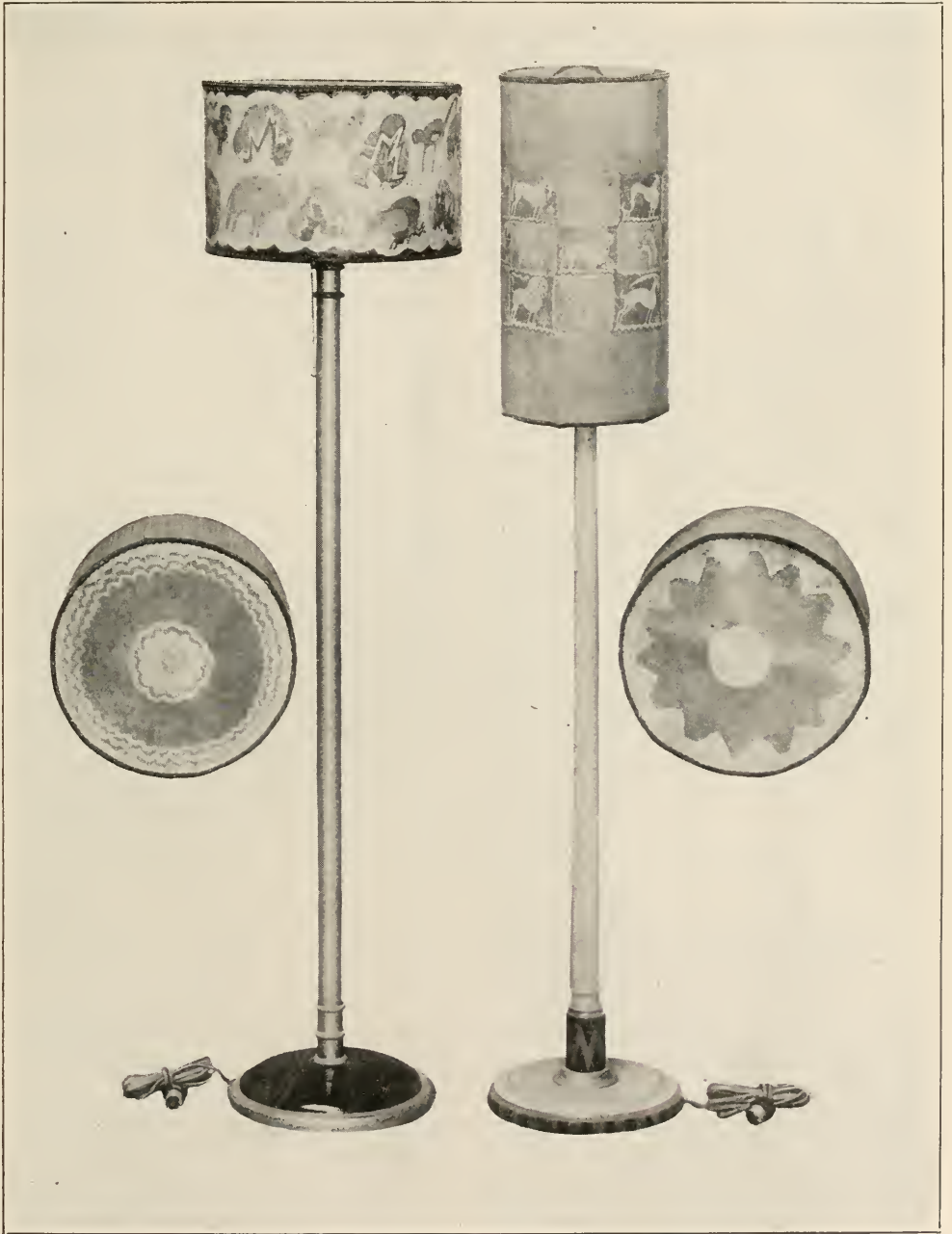
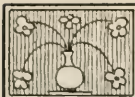

FIG. 3. LAMPS AND SHADES DESIGNED BY ALFONSO IANNELLI.

ously delicate, simple in appearance and significant in design." Along with this work of furnishing complete interior fittings he designs and sometimes makes such objects as the lamps and shades shown in Fig. 3. Nothing seems to be

too humble in its use for Mr. Iannelli to design and make.

This statement and his creed explain why his studio is full of suggestions for teachers of manual arts as well as art craft workers.



EDITORIAL REVIEW FOR THE MONTH

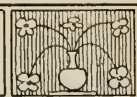

TRAINING IN ART CRAFTSMENSHIP

THERE are two main reasons for training in art craftsmanship: The first is to increase the number of appreciators of art products; the second is to multiply the number of workers who are skilled in art processes.

The appreciators are those who experience satisfaction in beholding or possessing beautiful things made with human hands or with machines under the control of human minds and emotions. They are those who are conscious of the presence of beauty in design, in curve, in color combinations; they are the ones who frequent art museums, who seek out the choicest patterns in textile materials and home decorations; they admire fine buildings and fine books, colorful gradens and pageantry, exquisite jewelry and sculptured marble; they are sensitive to beauty in many forms. The appreciators are the real consumers of art products.

The workers who turn out the art products are relatively few in number but they possess the talent, the taste, the designing ability, the skill of hand, the knowledge of processes that enables them to add beauty to things of utility. They have the power to record some of their emotions in material form so that they can be transmitted to other human beings whose emotions are tuned to catch the message. The worker—the true art craftsman—is the transmitter of the message of beauty, while the appreciator is the receiver of the message. The worker, it is often said, possesses creative skill.

Yet, more and more, it seems to be evident that there is a creative side to the training of the appreciator—the user, the consumer of art. The person who wears beautiful garments or arranges

objects of beauty in decorating a store window or makes use of type and stock ornaments in composing a page of advertising must to some degree be a creative artist. Moreover, in these fields of art activity an adequate degree of appreciation cannot come without the exercise of some creative effort because *appreciation* is not a *general quality* of mind and feeling so much as it is an intellectual and emotional reaction in the presence of *specific types* of art products as jewelry, needlework, wrought iron work, sculptured ornament, mural painting and many others. Art appreciation just as truly as mechanical appreciation, must come from *experience with specific* products, processes and materials.

If this is true, then the problem of training the appreciator or consumer of art products, as well as training the producer of art wares, is solved only by giving the students *experience* in the various materials and processes, the possible forms, colors, arrangement of the several kinds of art products that enter into modern life and living conditions. The appreciation of the art in textiles, for example, cannot come wholly from learning to draw plaster casts of the human figure nor from the pursuit of the ordinary college course in the history of art. It has to come thru experience and study of textile materials and processes and products, and thru the use of textile products and of forms appropriate in textile design and of colors of textile materials. Likewise, appreciation of the fine art of wood-carving cannot come wholly from experience in the painting of landscapes or the study of miniatures. To appreciate art in textiles one must have experience with textiles whatever else he may have that will help enrich his appreciation. To appreciate the art

of wood-carving, one must have some experience with wood-carving.

TO EDUCATE APPRECIATORS

IT follows, then, that to determine what forms of art craftsmanship should be taught to adequately equip art appreciators of today one should seek first to find out what forms of art are found in the life and living conditions of today, rural as well as urban.

A very superficial examination of the streets and the stores of our cities and of the homes in which we live and the clothes we wear will reveal art products which may be classified as follows:—

1. Posters, lettered cards and signs, painted bill-board advertisements, electric signs and transparencies.
2. Stage settings, store window displays, and mural decorations.
3. Printed title pages, Magazine illustrations and display advertisements.
4. Gardens and other products of the art of landscaping thru the planting of shrubs, flowers and trees.
5. Buildings involving the applications of the principles of good architectural construction and decoration.
6. House furnishings—furniture, floor and wall coverings, etc.
7. Clothing and millinery.
8. Photographs and photo-engravings.
9. Pottery, tiles, ornamental work in clay, cement, and other materials.

If these are among the arts of our modern life, and if they are worthy to be continued, and they ought to be appreciated, some experience in these are appropriately gained in school. In fact, the school that trains appreciators of these arts must provide for such experience in its curriculum. Why not? To illustrate: Is there any reason why the fundamentals of the art of landscaping should not be taught in the schools? The pupils of every high school

—rural as well as urban—could profit by a study of this form of art craftsmanship. They would learn the different styles of artistic planting; they would observe the characteristics of the foliage of various trees and shrubs at different times in the year; they would learn the charm of formal planting in emphasizing the characteristics of stately buildings, and, to quote from a professional, “the satisfying beauty of the naturalistic planting which ties together building and grounds, transforming them into a magnificently set jewel.” They would find out that they can play with walks and drives and flower beds and shrubbery screens and tones of berries and seed pods and spots of evergreens in working out the garden of their imagination; they would learn how to paint a picture with masses of foliage and flowers instead of pigments; and while doing so, they would learn those eternal principles of all the space arts: Simplicity, balance, harmony and unity.

As to the possibility of such art training functioning either in appreciation or occupation, there is no question. And what a transformation a single generation would bring in our town dooryards and squares, and in our farm yards, too, if every high school student would learn to apply even a few of the most elementary principles of the landscaping art! A very few students might continue the study in a more advanced school and make landscaping a profession, but this would be only a very few compared with the number who would appreciate the art sufficiently to cause them to employ an expert or use their own hands to beautify their own surroundings.

It would be easy to multiply illustrations. One might say almost the same concerning stage settings and store-window display or house furnishings or clothing and millinery, and so on thru

the list. But this is unnecessary. The point is that for purposes of appreciation as well as for production, training in art craftsmanship must be concrete and practical. Instead of teaching pure design in the elementary or high schools, teach design thru experience in some art, handicraft, industry, or profession. Pure design belongs to the college, not, as a rule, to the schools of lower grade. Instead of long, dry courses in freehand drawing and design, give intensive, short, practical courses in art crafts and occupations. Suppose that a given high school were to offer six of the nine types of work suggested above, and that a given student were to take four of these: for example, posters, printing, landscaping and house furnishings, is it not within the realm of probability that if these were well taught—with some real practical experience in each—he would have acquired more of value in modern life than if he had spent the same time in formal and abstract problems such as have been common in art courses in high schools? It seems to me that this is hardly fair to question. But, superficial work must not be tolerated. He must make posters of commercial value or near-commercial value; he must set type and do real artistic printing; he must make landscaping plans and have a part in carrying some of them thru to reality; he must design and make some real furniture and study its relation to other items of home equipment. The designing must be guided by experience in execution of the designs, as well as the execution be guided by the working drawings.

TO EDUCATE WORKERS

WHEN one comes to the training of the worker in art craftsmanship a new factor enters the problem. All students with normal capacities can be

successful to a greater or less degree in becoming appreciators of art craftsmanship, but a far less number can meet the standard of the successful producer of art goods and wares. To be both artistically and economically successful as a producer is not possible with any large proportion of the students of a given community. And so the question of talent or aptitude or capacity is of first consideration in the training of art producers. If a given school or course is definitely planned for producers then there ought to be some way of reserving that course for students who have the particular qualifications. It is a waste of the time of students and of the money set apart for art education to allow every student who has an impulse toward art to enter upon a vocational course in art without demonstrating in a preliminary "finding" course, which, probably, should be planned fundamentally like a course for appreciators, that he has ability which, if properly developed, will enable him to be successful as an art worker. Just what constitutes success may be difficult to determine and just how to select students wisely may be a hard problem to solve, yet the principle involved is a correct one.

In selecting students it is important that some of the tests consist of real experience in the arts being considered. This is an added reason for having the preliminary course, which is planned for appreciators, consist of real experiences and not merely formal exercises without appreciation or use.

A second element in the training of workers needs emphasis. Any sound course of preparation for workers in the art crafts involves training in processes and the use of materials—actual experience with tools and machines in producing—as well as training in drawing and design. This does not mean that

the worker must necessarily have equal skill in all phases of the art or craft, but it does mean that he must have had fundamental experience in all. To design furniture successfully a man must know the processes of cabinet making including wood-turning, wood-carving, upholstery and wood finishing. To be a wood-turner or a wood-carver of the type that is desired he must know drawing and somewhat of design. No school of art craftsmanship should adopt the extreme sub-division of labor that has become common in many factories. *Indeed, it is believed that many factories would not carry the sub-division so far were they able to secure adequately trained workers,* and that they would have less difficulty in maintaining a high standard of product at less cost if they had more adequately educated workers. When the small shop or the individual craftsman is taken as the unit of production there is no question but that each craftsman must know the whole of his craft. Nothing short of this individual unit is the safe standard for schools to set in many of the art crafts and in others only the relatively few main sub-divisions of the craft should be recognized as a course basis for school training. Specialization should be allowed but never at the expense of foundation experiences in the whole craft. In this way only can America build up a worthy standard of art craftsmanship and an adequate supply of trained workers.

REAL EXPERIENCE ESSENTIAL

IT MAY BE said that there is one fundamental factor in training for both appreciation and production, and that is real experience. We ought not to have to be told by a psychologist that appreciation is based upon experience, yet in many, if not most, school courses we proceed as tho we never heard of such

a fact; we rush students thru superficial courses which tell *about* art and craftsmanship, but give no contact with the real thing itself. At best such courses give only intellectual data which cannot function effectively until illuminated with emotional and added intellectual material that comes only with fundamental experience in the art itself. Yet, if we will but make a few observations we are forced to recognize that real appreciation is a matter of slow growth and comes only as the result of experience. Reading what somebody says of what somebody else did in art means very little in the art development of the reader if he, himself, has not in some vital way come in contact with the essential elements of that particular form of art. One can recall his own experience and realize the truth of the principle involved. He can recall that he never had any adequate appreciation of the beauty of wrought iron work until with hammer and forge and anvil he learned to bend and shape heated iron. He never caught the subtle beauties of a fine example of water-color painting until he had tried his hand with brush and pigments. He never exercised proper discrimination in selecting carved or turned pieces of furniture until he learned some of the niceties of the arts of turning and carving.

Experience is surely the basis of appreciation, tho the schools have not usually recognized this fact. Experience is also essential to skill. This fact is, however, quite generally recognized. The schools concede the fact that experience is necessary to produce effective workers. Perhaps they have conceded too much in this direction, and have mis-applied some of the psychology of habit formation, but that is another story.

To recognize the importance of practical experience with tools, processes, materials, pigments, etc., etc., in the art-

craftsmanship training of both the appreciator and the worker ought to lead to more effectiveness in schools and a higher art standard for the nation.

MORE EXPERT CRAFTSMEN NEEDED

OUR attention has been called to a recent article in the *New York Times* which states that a recent survey of the silver working industry under the auspices of the National Society for Vocational Education revealed the fact that "practically no silversmiths are being trained in this country except as they may pick up knowledge thru experience in the shops." One manufacturer is reported as saying "Unless some way is found to train expert workers in silver, the industry will die out in this country within ten years."

The article then continues as follows:

In olden times the expert workman took young men as his assistants and taught them the secrets of his craft, a "mystery" as it was originally called, thus building up the system of apprenticeship that lasted well into the middle of the nineteenth century. With the invention of machinery, which permitted reproduction in quantity from the original model made by the artist, schools became necessary in order that leaders might be trained as designers and expert craftsmen. To meet this need France had before the war 32 industrial art schools fed from over 200 schools of design; in England there

were 37 industrial art schools, and the South Kensington Museum supplied traveling exhibits to some 350 art schools and 90 county museums; while Germany was credited with 59 industrial art schools, all comparatively new and well equipped.

In the United States there has been no such response. There are in this country only two important industrial art schools, and there is not even one lending museum, tho such an institution would be of enormous value to factories with studios far from art centers and to the smaller cities.

Even cosmopolitan New York City has no great industrial art school. There is no school for jewelers or silversmiths, none for bookbinders, none for lithographers and other workers in the graphic arts, none for wood-carvers and furniture makers. The Board of Education has recently started a textile school in an old building, and it maintains a free evening industrial art school in a building used during the day as an elementary school, and therefore entirely without equipment, so that it is scarcely more than a design school.

There is, however, a sign of stirring to meet this want. The Chamber of Commerce of the State of New York has recently recognized the need for the training of expert designers and craftsmen, and, under the auspices of its committee on education, there have been conferences of representatives from the following industries: Jewelry, silverware, silk, lace, cotton, carpets and rugs, furniture, interior decoration, lithography and wall paper. And it is hoped that out of this movement on the part of those interested on the industrial side and of organizations and individuals interested on the art side there may be developed an industrial arts institute that will help America to adorn and beautify that which enters into the daily life of so many millions.

I believe in art because I believe in richness of life. I believe in art education because there can be no complete education without it. I believe in art education not as another subject added in the curriculum, but as an attitude and a spirit which suffuses the whole. I believe the industries, expressing the fundamental instincts of construction, are its roots; I believe that science and history are its twin stalks; the former developing insight and skill, and the latter giving a sense of value in all which education involves. I believe that the Arts in the broadest sense of the term represent the flower of the plant, not only adding beauty and fragrance, but making possible a rich fruition of democracy's best human institution. I believe that both in education and in life art is present wherever a process calls forth in a single expression the whole nature of the individual, in an attempt to interpret and to satisfy a social need.

—WILL GRANT CHAMBERS.

A POINT OF VIEW

FIVE months with the Rehabilitation service of the U. S. Veterans' Bureau gave, as I anticipated, varied and interesting experiences. Some day someone will write a book on the successes and failures of disabled soldier rehabilitation. The problem has about as many angles as there are men involved. The following illustrations have real meat in them and each tells a story of an immense problem, not as yet, solved.

1. Here is a letter from a totally blind boy who also lost both hands in the explosion of a hand grenade. Before the war he was a machinist. The letter came to me typewritten. There are a few "mistakes." Read it slowly and think of all that is involved. He is the sunniest-faced disabled trainee I ever met. He is as hopeful in all his movements as his letter indicates.

Dear Major Dean:

I was pleased to meet an official of the Veterans' Bureau coming to visit us directly as such. You may be interested to hear something of our work at this, the Red Cross Institute for the Blind.

"We have about one hundred students attending though all are not totally blind. I think that basketry and music are the most popular of the vocational courses offered whereas, I find the pre-vocational work in the academic department most essential as a background for any prospective endeavor. I hope that in our interview, you did not get the impression that I was in training without any definite idea as to my future. The reason that I was so uncommunicative was because I did not know to whom I was talking, my experience with news reporters has made me cautious for my plans are not to be made public property until I am certain of their feasibility. My present intention is to study law as I said in our talk, however, my aim is to become a counsellor-at-law.

On my entering training I was given a special instructor by the Federal Board, also without hands, who was able to understand my position and give me the benefit of his experience. I was unable to do anything for myself prior to coming here; in a short time, I was feeding myself, shaving, combing my hair, brushing my teeth, and, excepting collar, tie and shoes, I dressed myself.

After I had gained my independence this instructor was no longer employed for me.

Though I may not read Braille (Raised Type) I can and do use the Braille writer without any special appliances. My typewriter was a little more difficult. A special attachment was required to make its use possible. During the construction of this, I was taught the keyboard, inserting of paper in machine, folding letters and inserting in envelopes; so that I now handle my correspondence without assistance.

I feel greatly benefited by the advantages and opportunities offered me by this school through your Bureau.

Yours sincerely,

Carl Bronner

2. Here is a story that has a poor beginning and so far no ending. It is a story of governmental ineffectiveness due to careless local supervision. The trainee appears to be a vocational hobo. His wanderlusting has cost the government so far at least \$2,800. He was formerly a street-car man. He started in training for salesmanship, crisscrossed all over the salesmanship road, changed over to music and disappeared. Who and what started him on the vocational road and who and what watched his progress, the Lord only knows. Volumes can be written about such cases. They are too numerous for effective rehabilitation.

"Training authorized on July 14, 1920, for a course in salesmanship at University.

Discontinued training on August 15, 1920 on account of not being physically able to follow course.

Resumed training November 10, 1920, in commercial course in hardware salesmanship.

On November 20, 1920, changed to placement training with ——— as auto accessory salesman.

On January 1, 1921, began training at vocational school as salesman.

On February 18, 1921, entered placement training with ——— Co. as produce salesman.

On March 15, 1921, changed to ——— Company as salesman.

On March 31, 1921, changed to Auto Supply Co.

On April 6, 1921, changed to Electrical Co., as electrician.

On May 20, 1921, changed to local office with objective as violinist.

On May 23, 1921, changed to College of Music in violin lessons. Objective, violinist.

On May 30, 1921, changed course to violin and Harmony.

On June 30, 1921, he disappeared and whereabouts unknown.

3. This* buddy concluded that he would cut himself off the trainee's payroll and go it alone. The letter is addressed to his former supervisor of training. It is a dandy message of courage and promise. One can easily guess that he is not looking for a bonus. But, if he gets one, it is safe to say that the money will go into the bank or be used on the farm.

Dear Sir:

To reply somewhat to your letter of sometime ago not just knowing the date of same as I have been very busy buying stock and getting my home fixed up so I can live. I got a letter from Mr. ——— some time ago but haven't answered it yet. Well now I am going to give you some Ida of what I am doing as they would not give me what I asked for in the as for training and pay I decided to get busy and make my time and money which the good Lord and Uncle Sam has and yet giving me so I got me a farm first, then as follows one cow, 2 hogs, some chickens about 15, and 1 more hog on the 3rd and put it out on half to be fattened, 2 calves, 1 good colt, but seeing it would be some time before the colt could work I got me a good horse and if you could see him and see him do his first work you would think he was sure a 'Dandy' He is only 4 years of age and weights 1300 lbs., and just works as an old horse to a sled, that's all I have tied him to yet. I got me a wagon but have not put him to it yet as he is young and fat and no one to help me hold him. May may work good in it thoe. I just wish you and all the boys could see me on my little farm most all good fruit judges say I'll have \$500 worth of peaches and also raspberries and strawberries and about 100 apple trees of bering age good fencies and good grass as well as good land and don't you just guess at it and say 'Jess is proud of his self' just say right out 'Jess is proud of his self and of his country which he lives.' I am thankful for my help which I have received from you. Mr. and others. Yes, let me say it out loud, May God bless you all. I wish all the

boyd could do as well as I have or even better, and perhaps some is, but I fear some is not looking ahead enough. I want you to give my good wishes and thanks to Mr. or Prof ———. I know you and him both miss me for my growling way, but I was never very well there so you must forget that I would treat you all the very best I could if you would come to see me.

4. This fellow has the right idea. He says "no training school and government pay for me. Give me a farm and I'll either work it or rent it. Anyhow let's clean up this rehabilitation job quickly." He is not "long" on spelling and punctuation. And neither is he "short" on rehabilitation philosophy. If all trainees were like him and it was legal for the Government to meet his request the problem of rehabilitation would be quickly, effectively and economically solved.

Treasury Department
Washington, D. C.

I rec. a letter from the Federal Board a few days ago and they wanted me to come to ——— and take a course of training and they ofered me \$135.00 a month But I cant do it for I would have to broke up a home I have a wife and to little children and I am a renter and I have a crop of wheat saun and a team to tend to and if I broke up it will take all the Board pays me to rent a house and feod me and my famly and whn I got done training I would be worse of then I am now for when I had to go to the army I got my notice only 2 days before I had to go to camp so I had to give away what I had and I have never got as much back again so now I got what up and I am not able to do very much for my self nor no boy else.

But I told the federal Board just to give me the money that they think it would take to give me that training and I would buy the farm I live on and stay at home and if I get so I cant work a toll I could rent my farm then and supart me and my famley a little home would do more good then three times the amount of money would for I can rent it and for my liveing as long as I do live so the Board dont want to do that so I want broke up to take no training so I would like to hear from you at once."

This batch of letters might be extended to cover the gassed man who has great physical difficulty to carry on certain vocational environments, the "shell

shocked," so-called, whose correspondence is often the most shocking thing about him, the psychopathic chap who was not vocationally adjusted before the war and will never be fitted to carry forward, and,

finally, the "mental flatfeets," who cannot stand up to an intellectual task and for whom no amount of intellectual arch supporting will accomplish anything.

—ARTHUR DEAN.

WASHINGTON CORRESPONDENCE

BUREAU OF EDUCATION CONFERENCES

TWO dinner-conferences of specialists in industrial education, under the direction of the United States Bureau of Education, were held during January, in connection with the Kansas City convention of the National Society for Vocational Education, and the Milwaukee convention of the Vocational Education Association of the Middle West. The Bureau has also recently accepted invitations to hold similar conferences in connection with the Rochester convention of the Eastern Arts Association, and the Cincinnati convention of the Western Arts Association.

PROBLEMS OF ORGANIZATION

A CONSIDERABLE number of these conferences have been held, beginning in 1914. The attendance at the Kansas City conference, January 4th, was the smallest except one, but the program was one of the best. The subject was "Problems of Organization in Industrial Education," and the text was a statement made by a prominent educator some time ago that attracted my attention:

In comparison with the outlay which business and industry make for supervision, our school systems are grossly under-manned on the supervision side.

It occurred to me to invite one or two men who have made a conspicuous success in organizing business or industrial enterprises to make an analysis of their administrative machinery, for the purpose of determining what applications might be made advantageously to our

programs of industrial education. The outcome exceeded my expectations, and I was fortunate in securing for this assignment William Pitt, vice-president and general manager of the Irving-Pitt Manufacturing Company, Kansas City, and W. W. Kincaid, president of the Spirella Company, Niagara Falls, N. Y.

Mr. Pitt defined an organization as a machine composed of human elements, designed to achieve a volume of work too great to be accomplished by a single individual without loss of efficiency. There must be, first of all, a clear conception of the task to be performed, and then the elements of which the organization is to be composed must be carefully selected with reference to the special function which each is to discharge, and these elements must be skilfully fitted together.

The manager must give attention to possible sources of trouble, and keep the concern going smoothly. Management seeks to aid subordinates to succeed. A general manager is successful if he makes his subordinates successful.

The manager should give attention to current checking of the working of the administrative machinery, rather than to periodical checking. It is better to have constant checking, analogous to what the medical practitioner calls a "clinical" examination, while the patient is still alive, than to wait for a "post mortem" examination to explain why the business failed.

In our plant we consider that if we can succeed in carrying the individual employee on to higher

and greater usefulness, we shall have discharged a far more important function than the manufacture of any commodity.

Mr. Kincaid began by saying that business, properly conducted, is a great school; and certainly our schools are the greatest business in America. Business men and educators, therefore, have common ground on which to discuss our problems.

He defined a successful administrator as one who can "shed responsibility," and declared that it was this qualification which made it possible for him to be in attendance at this conference, altho president of three organizations.

Referring to education as a continuous, life-long *process*, rather than a *result*, he defined vocational education as "the process of drawing out and developing the capacities of the individual to a point of efficiency, in harmony with his native bent for his particular work." A number of illustrations were given of the ways in which business and industry contribute to this process, and of the importance of efficient administrative machinery. A suggestive plan of co-operative committee organization was explained at length.

SOUND PRINCIPLES OF ORGANIZATION

FOLLOWING these two addresses, Professor K. G. Smith, of the University of Michigan, gave a splendid analysis of the guiding principles of organization. He began by outlining four general principles. Every executive should say to his associates:

(1) I am always glad to listen to criticism, and am not afraid of it; but make your suggestions constructive; do not simply find fault and "knock."

(2) I will not go over your heads in dealing with subordinates; no one of you should attempt to go over the head of any superior; follow the prescribed lines of procedure.

(3) I am a great believer in conferences, but the manager must finally make the decision.

(4) Let no one stand in the way of any individual's advancement; do not withhold information of better opportunities in order to retain any one in the service.

The discussion was ably summarized at the close by M. G. Burton, assistant superintendent of schools, Kansas City. But limitations of space compel me to bring this sketchy account to a close. For the same reason I cannot attempt at this time to write of the very successful conference at Milwaukee, January 11th, where we had the largest attendance of the series, 142, and an excellent program.

IN FOREIGN COUNTRIES

THE ALLIANCE OF ART AND INDUSTRY

IN presenting diplomas to the successful students at the Royal College of Art, London, the Parliamentary Secretary of the Board of Education, J. Herbert Lewis, made a very timely address which has been reported by the *Times Educational Supplement* as follows:

I regard these diplomas as guarantees for the future of English craftsmanship. Students who go out into industry with these diplomas will go out having written upon their minds certain standards of taste and of thoroughness in workmanship from which they will not willingly suffer a lapse. The diffusion of these standards cannot fail to be a means of beautifying our common life and of profit

to our national industries. Late in time we are learning how grossly our fathers erred in postponing beauty to cheapness and commercial convenience. They thought it would pay, and no doubt individually it did pay them. But it wrought a subtle deterioration in the hearts of the people—a heavy devaluation in the real capital of the nation. Let a man approach London from any point of the compass and he will understand what I mean. Goethe said that every one should live in a place containing at least one beautiful building. The object of the Royal College—comprehensive but attainable—should be, and is, to secure that beauty in design, whether for architecture, decoration, or handicraft, and in the practice of art in all its forms, should not be the exception but the rule.

We have spoken of the beautifying of life: we come to the profit of industry. And here I must

pay a tribute on behalf of the Board to the important services rendered by the Principal in creating an *entente* between art and industry. We have long been conscious of too wide a divorce between them; special attention was drawn to the matter in the report of the departmental committee of 1911. They spoke of "the real want of sympathy between the aim of art and the aim of commerce," and some discouraging evidence was cited. All the more credit therefore to Professor Rothenstein for his labors in removing the reproach of that disunion; and it is a source of great satisfaction to learn of his signal success. He has, as I understand, established friendly relations with the Federation of British Industries; he is in a fair way to persuading the industrial world that the college really has something to offer them—something that will increase the value of British goods and make it worth a manufacturer's while to employ South Kensington students. He has already, I am informed, obtained the help of the great federations in finding suitable places for his pupils, a mutual interchange of service which bodes very happily for the future both of the college and of the industries it is eager to help. There may arise out of this incipient alliance a result which many of us have very much at heart—a result which, in my opinion, is essential to the economic progress of this country—namely, the restoration to their ancient dignity of the manual trades of England. I cannot help thinking many persons at present enter clerical occupations, not because they are at all suited for or attached to that very necessary branch, but because they or their parents suppose that some sense of inferiority attaches to the manual trades and that boys and girls who have gone further than their fellows in their education would be wasting themselves and the money spent upon them by reverting to manual occupations. I am afraid that heresy has struck its roots very deep, and for its extirpation much labor and patience will be required. Crafts differ from one another in dignity solely in accordance with the spirit in which they are undertaken. We have only to think for a moment of the artistic heritage of Europe to realize how ludicrously false are the standards of judgment which pre-suppose any inferiority of status in the man who earns his living with his hands. Would anyone look down upon the glazier of Reims or the violin maker of Cremona? What I wish to see established is the conviction that whatever a man is going to be he has a citizen's right to a good general education, and that then it is open to him to enter upon any craft he likes with equal prospects of honor so long as he lives up to the very exacting responsibility of the true craftsman.

EDUCATING PUBLIC TASTE

THE London *Schoolmaster* quotes Lady Rhondda as saying at the opening of the Englishman's Fair at Westminster:

If the public taste is not artistic it is because the art and craft workers have failed in their duty to educate it. The beauty of goods produced in quantities must depend on public taste, but there is a personal touch and individuality about hand-made goods which machine-made goods always entirely lack. In training the public taste, hand and craft workers have a double duty and responsibility.

Then the report goes on to say,

One wonders if her ladyship has been comparing the cheap stamped fingerplates with the hand-made repousse; the cheap furniture smothered with machine-made ornaments with the solid, well-made, designed-for-use articles; the pottery covered with intricate projecting designs, receptacles for dirt, and the simple, plain-curved, useful articles in use by our grandparents. Comparisons cause one to think furiously at times at the utter waste of it all. The tradespeople, who should know, will say that the public demand these trashy, over-ornamented articles, and reject the good and simple, but one is very much inclined to doubt this excuse; for even if one wants the latter variety, more often than not it cannot be obtained. By putting one's ear to the ground one can hear the rumble of revolt against this overdone machine business; there is an awakening of a new appreciation of the simple and useful in the convenience of modern life which promises to sweep away the shop windows full of wasted effort. The handicraft teacher has played, and will continue to play, an important part in inculcating an appreciation of the simple and well made.

TESTING COLOR VISION

THE practice of testing the color vision of all students of art has been adopted by one of the polytechnic schools in England. The students are examined individually previous to entering upon any course of study in which competent judgment on color is essential. Color cards are used. "They consist of a series of lithographed cards having irregular spots of identical shape but different colors." It is said that anyone who can "read" the set may be certain that his color vision is not in any way defective.

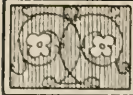

PROJECTS, PROBLEMS AND NOTES

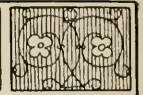

ANCIENT BREAD CUPBOARDS

ON the cover page of the October number was one of the three historic bread cupboards in the transept of St. Albans cathedral in England. The other two of these cupboards are shown herewith. No one is likely to wish to duplicate them

in front, but make it very strong. The hinges must be wrought of good iron and the bolt of the lock must be of iron. Hammer the hinges into beautiful form if you will. Carve the wood if you please, but make the cupboard as beautiful as you can." And so each of these may have been de-

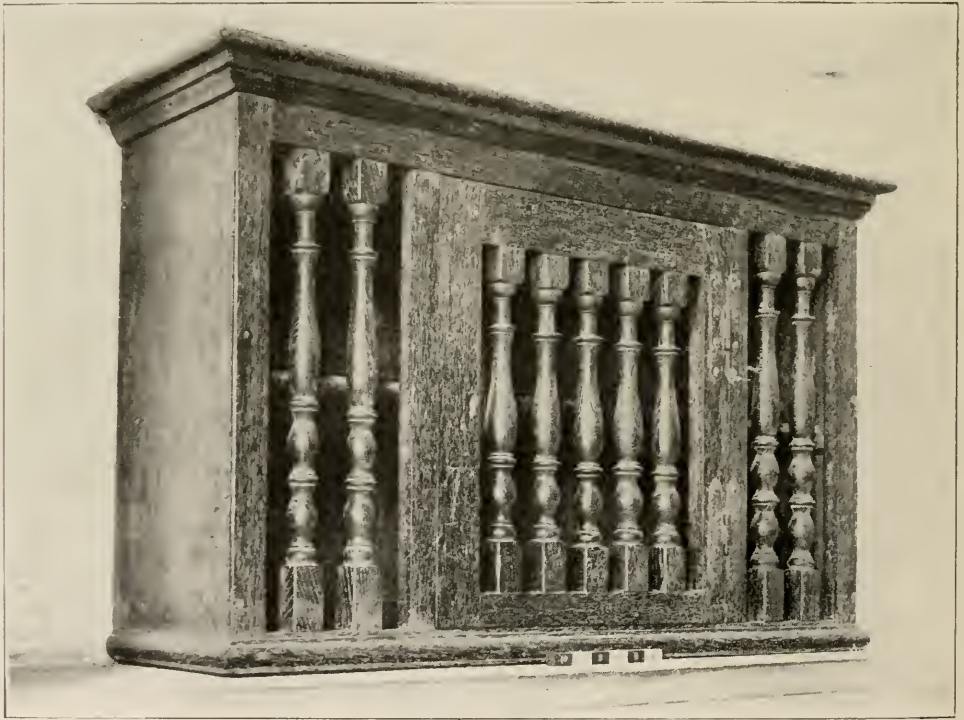

ANCIENT BREAD CUPBOARD IN CATHEDRAL, ST. ALBANS, ENGLAND.

for modern use—certainly not for the same use, because our charitable organizations do not distribute bread in the same way it was done when these cupboards were made, but they are interesting as examples of ancient craftsmanship, and perhaps they may be suggestive to some designer of cabinets or of spindle turning, or of carving or of hardware.

One can easily believe that the good man or woman who founded the bread charity went to three cabinet makers in that charmingly picturesque old city of St. Albans, and said to each, "I commission you to make a bread cupboard for the cathedral. It must be so many inches long, so many inches high and so many inches deep. It must be of oak, and let it have open spindle work

signed and made in a different shop by a different workman.

Or, it may be that one of these was made and used in the early years of the charity, and that as the city grew or times became hard there were more poor people who came to the cathedral to ask for bread, and so more loaves had to be provided and another cabinet and then another to keep them in. In that case, the three may have been made in the same shop by the same designer at different times, and so represent the development or a change in his taste. Perhaps so much bread was required that, in order to prevent crushing the bottom loaves, a shelf was put in two of the cupboards, for it seems clear that in one of them, at least, the shelf was an after-thought and

not a part of the original design. Moreover, it was put in by some one who displayed very little skill or taste in the way he did it.

Above everything else, these cupboards seem to reflect the spirit of the craftsmanship of the period in which they were made. There is nothing about them that suggests the modern factory with its quantity production. They are individual productions, and, with all their inaccuracies and varia-

the beautiful in the old. It remained for Dege of Quincy, Illinois, who has the industrial art, to build the old and pleasing furniture. If you will visit his workshop, you will find him making furniture that appears to be a century old. He needs must use queer tools and with them he turns out the antique so cunningly done as to be pleasing to the eye of the expert. Mr. Dege and his son followed this unusual vocation in Germany. The

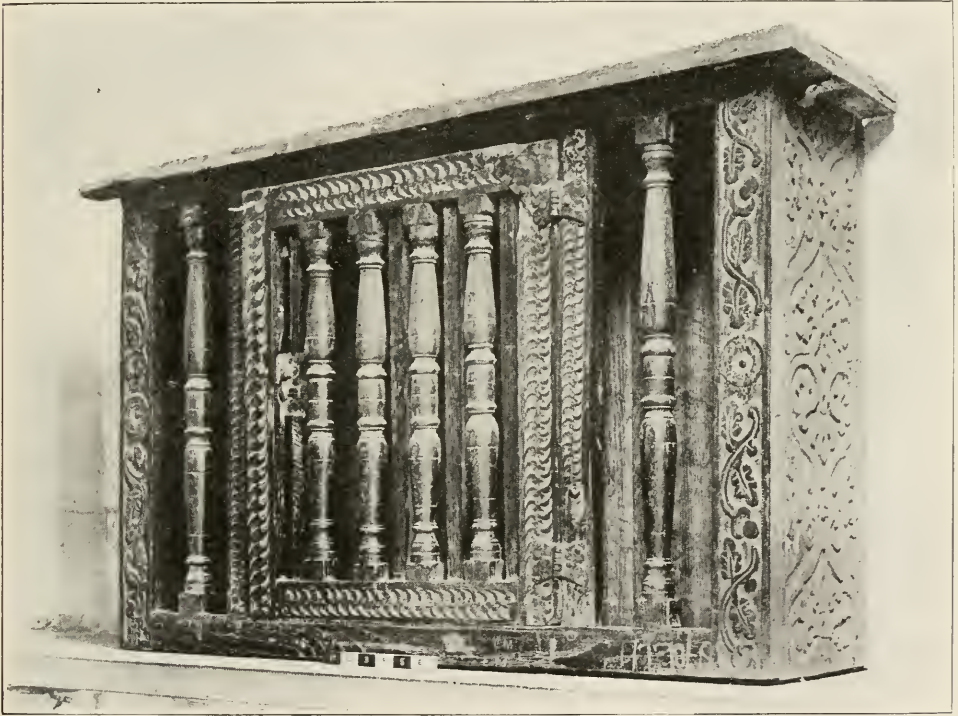

ANCIENT BREAD CUPBOARD IN CATHEDRAL, ST. ALBANS, ENGLAND.

tions from the type forms, they are works of art. The spirit of these cupboards, if not their form, is indeed in manual training shopwork today.

OLD FURNITURE THAT IS NEW

OUR trend towards vocational education not only brings out unused possibilities of childhood but gives inspiration and new life to grown up people. Our complex social life gives to many leisure. Leisure brings study and investigation, which in turn brings back the beautiful of yesterday in the craftsman arts. Old furniture is beautiful not because it is broken or marred, but because of rhythm, line and symmetry. Some of us love

son studied in the art school of Munich where this type of work is made a speciality. The young child is always attracted by unusual tool and pleasing pattern. The boy with an artistic temperament may find great value in copying or reclaiming a bit of colonial furniture. The story of civilization may be read by some thru books and pictures, by others thru the guiding of the hand along the beautiful in the manual arts of yesterday. The accumulated treasures of the craftsman art should find a place in our school. We may have need of the lesson of "progress," but we also need to have our dreams of castles in Spain.

—BYRON COSBY,
Kirksville, Missouri.

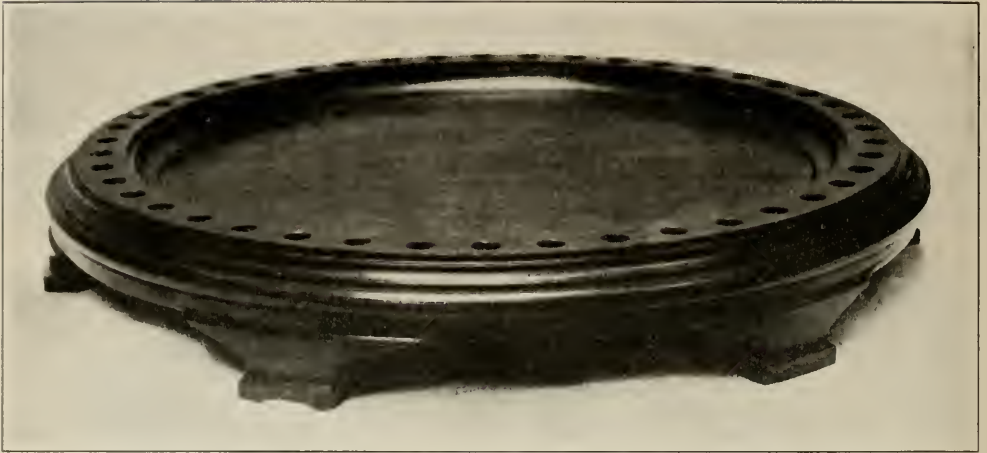

BIRTHDAY CAKE STAND.

A BEAUTIFUL OLD CHAIR

ANOTHER delightful example of Medieval craftsmanship is the chair in the Museum of Fine Arts, Boston, shown in another illustration. Notice especially the turned legs.

BIRTHDAY CAKE STAND

IN THE birthday cake stand we have a thoroughly modern piece. Its use is American; its moulding may be considered European; and its legs Oriental. It is an ingenious application of the forms of past ages and foreign peoples to the social customs of today. It is, therefore, quite "original" because it is a new combination to supply a present need. The plate was designed "to avoid the necessity of putting dripping candles on a birthday cake." As will be seen from the working drawing, it consists of a stand or plate with a removable rim in which are a series of holes to take any number of candles up to forty-four. When it is desired to cut the cake the rim of candles is lifted off.

The plate was made of cherry. The bottom part may be made of one-inch strips glued up with the grain "mixed" to avoid warping. The rim should be made in segments like a pattern.

This stand was the joint work of Thomas H. Ross, pattern making instructor, and William R. Reese, head of the drafting department at the David Ranken Jr. School of Mechanical Trades, St. Louis, Mo.

MIRROR FRAME

THIS is a very small mirror suggested by some of the mirrors of Colonial times. The picture at the top, however, is postcard size. This simple problem has good design possibilities.

MANTEL-CLOCK

THIS working drawing was received from W. W. Scott of Topeka, Kansas. It is a comparatively simple problem with a popular appeal, especially if well finished.

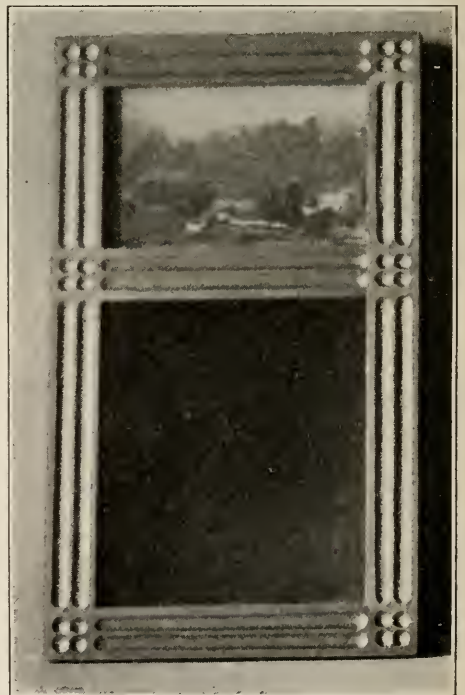

CARVED MIRROR FRAME.



CHAIR IN MUSEUM OF FINE ARTS, BOSTON.

BIRTHDAY CAKE STAND

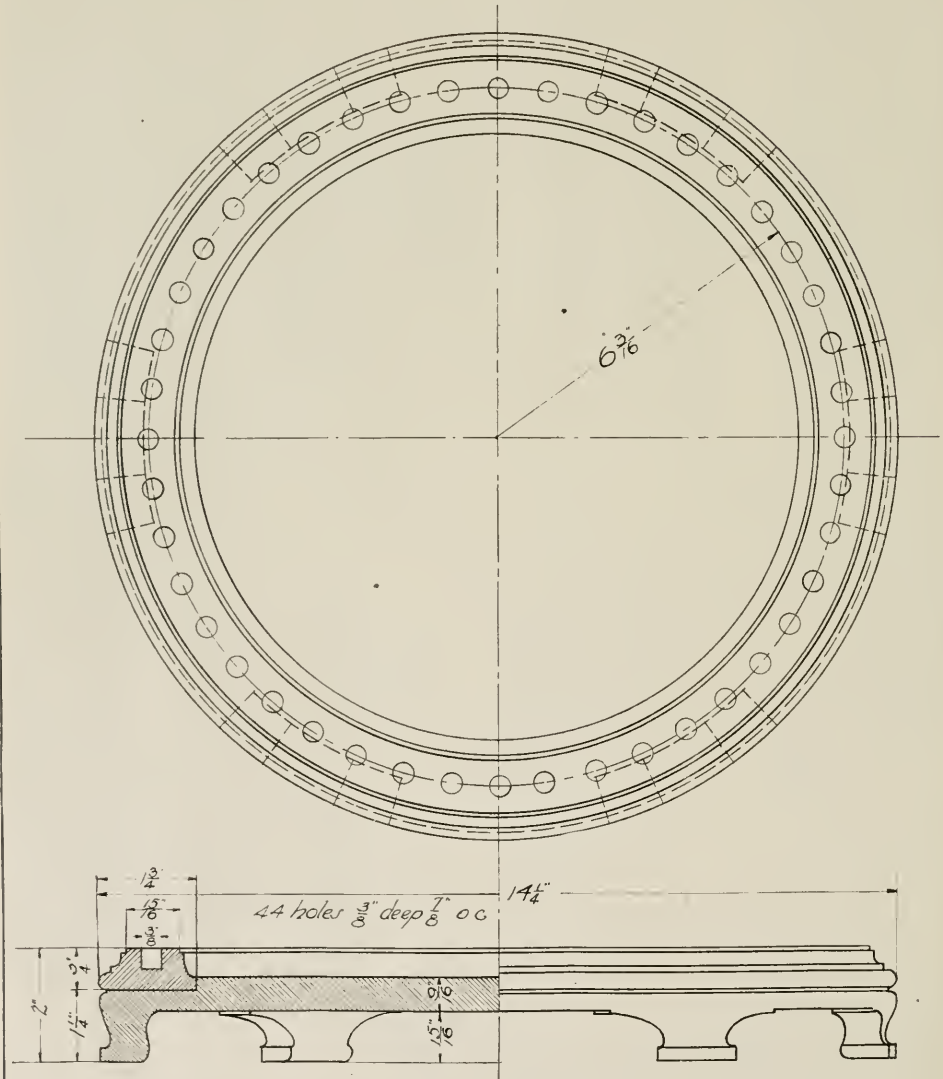

THE DAVID RANKEN JR.
SCHOOL OF MECHANICAL TRADES
DRAWING

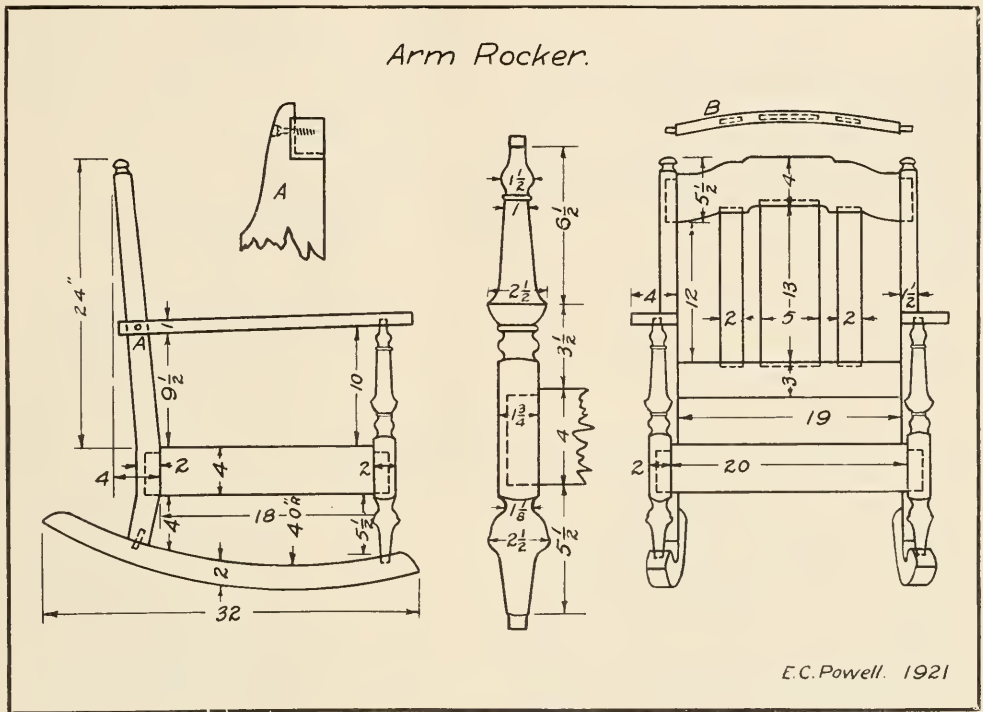

ARM ROCKER

THE accompanying drawing for an arm rocker is a companion piece to the William and Mary bookcase which was published in the August number.

This rocker will be most satisfactory, if constructed of walnut or mahogany; altho cherry or birch may be used. Oak is not a good material for turning, and consequently will not work out as well as a close-grained wood.

If the given dimensions are carefully followed the chair will "hang" well, and will be found very satisfactory as a low, comfortable rocker. It is truly a man's rocker, and the depth of the seat should be reduced to 16" if it is to be made for the comfort of the average woman.

If a low rocker is not desired, the side seat rails may be raised to 5" and 6 1/2", or 6" and 7 1/2" respectively.

When the back rails are curved, as shown at *B*, the tenons should be cut while this piece is of uniform thickness and of squared stock, to insure alignment when the back is assembled. The knobs on the tops of the two back posts are turned separately, and put on like door knobs.

The detail at *A* shows a good form for fastening

the arm to the back post. The screw can be countersunk and plugged, or a "button" placed over the screw head.

An enlarged view of the turned post is given, which needs no explanations. Mortise-and-tenon construction is used thruout, with the exception of these front legs. A dowel is turned on both ends of each leg, and it is fitted into the rocker and arm as shown. A 40" swing has proven to be about right for a rocker of this size. Both back posts and both rockers can be cut from a single board, with a minimum of waste, if care is observed in placing. (The author always uses templates for irregular pieces).

The seat should be upholstered. Most rockers do not have enough spring strength. I get best results when eight 12" coil springs are used. These should be placed in a removable, box, slip-seat frame; three springs at the front, three at the back, and two at the middle. This arrangement will allow for diagonal tying, and works out nicely. A well padded, smoothly fastened leather adds much to the appearance of the cushion.

The ordinary finishes may be used. If varnish is used it should be allowed plenty of time, between coats, for drying, and polished down with the finest sandpaper obtainable, or with steel wool.

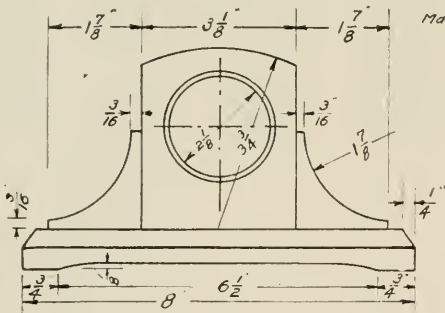
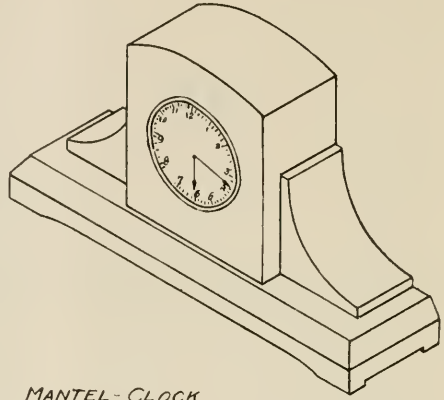
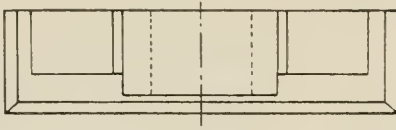

MANTEL-CLOCK.
Material - Walnut or Gum.
Scale - 6"=1'0"

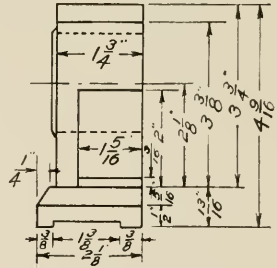

W. W. SCOTT.

COAT HANGER

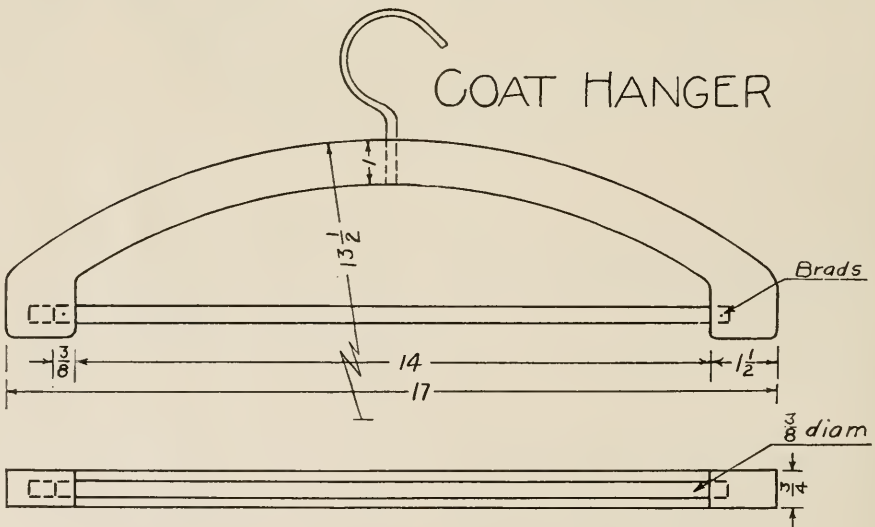

If the finish room is not satisfactory for varnish work, any room may be used, which can be heated to about 90°. If dust settles, it can be vigorously rubbed with fine steel wool, and polished with a good furniture wax.

—E. C. POWELL,
Massillon, Ohio.

WHY LUMBER IS STEAMED DURING KILN DRYING

FROM the questions asked by numerous students taking the short courses in kiln drying at the Forest Products Laboratory, Madison, Wisconsin, it is evident that many who operate kilns and handle lumber do not understand the object of steaming lumber in a kiln. There seems to be a common impression that the purpose of steaming lumber is to "remove the sap." This is far from being the fact, for when lumber is steamed it takes on moisture, as a rule, instead of giving off anything.

The reason for steaming lumber during drying depends on when it is done, but nearly always the treatment is given for one of the following purposes: (1) to heat lumber thru quickly at the start; (2) to relieve stress which otherwise would produce checking, casehardening, and honeycombing; (3) to equalize the moisture content and condition the

lumber ready for use at the end of the run; (4) to kill fungi and insects in the wood.

When lumber should be steamed, how long the treatment should last, and what temperature should be maintained are points which have been determined at the Forest Products Laboratory by experiments on many species of wood. A thorough understanding of the steaming operation is essential because the whole kiln charge can easily be ruined by too severe a treatment. One of the chief needs of many commercial kilns is proper steaming facilities, without which a high degree of success in the artificial seasoning of wood is impossible.

CASEIN GLUES EXCEPTIONALLY DURABLE IN DAMP PLACES

CASEIN glues are as a class more water-resistant than animal and vegetable glues, but they are not, strictly speaking, waterproof. There is no glue that is waterproof in the sense that it is absolutely unaffected by water after a long immersion. Nevertheless, there are casein glues that are so water-resistant that plywood glued with them will withstand soaking for many weeks in water or exposure for many months to a warm, damp atmosphere. Under similar conditions, animal and vegetable glues would lose their strength in a comparatively short time.



COPPER WORK DONE BY STUDENTS AT THE SEWARD JUNIOR HIGH SCHOOL, MINNEAPOLIS.

CURRENT PUBLICATIONS

Drawing from Memory and Mind Picturing. By R. Chatterson-Smith, formerly director of Art Education, Birmingham. Sir Isaac Pitman & Sons, Ltd., London.

Several years ago this Magazine published an account of the remarkable work in teaching memory drawing with reference to commercial art and design which was being done at the Birmingham Art School under the direction of Mr. Chatterson-Smith. This account spoke of his studio of live animals to replace plaster casts of antiques, and of the visits of his students to the museum, followed by the drawing of designs from memory, on the theory that the practical designer and art worker needs to have his mind stocked with form and color concepts which he may apply as readily at any moment as a writer calls up and uses words. The present book is an illustrated exposition of this theory and a study of the psychology of teaching drawing. The editor of the volume speaks of it as a pioneer work covering "new ground, untouched by earlier authorities."

The Graphic Arts. Modern Men and Modern Methods. By Joseph Pennell. The University of Chicago Press. Size $9\frac{1}{4} \times 6\frac{1}{4}$ in.; 315 pages; well illustrated.

This volume is from a report in shorthand of the Scammon Lectures given at the Chicago Art Institute in April, 1920. To say this, is to insure to the reader material of high authority and great value on the subject. This is the sixteenth series of lectures given at the Art Institute under the Scammon Foundation.

This particular series includes the following subjects:

1. Illustration—wood cutting and wood engraving.
2. Illustration—modern methods.
3. Etching—the etchers.
4. Etching—the methods.
5. Lithography—the artists.
6. Lithography—the methods.

Any teacher of printing will be glad to have this book in his library.

The Handicraft of Wood-Carving. By James Jackson with foreword by Walter Crane. Sir Isaac Pitman & Sons, Ltd., London. Size, $8\frac{1}{4} \times 5\frac{1}{4}$ in.; 68 pages; 49 line drawings and 15 halftone illustrations; price, \$2.00.

This book deals with the carving of conventionalized floral forms. It includes chapters on design, wood suitable for carving, tools and how to sharpen them, preliminary exercises, manner of

using tools, etc., and then a series of exercise pieces accompanied by directions for making.

Samplers and Stitches. A handbook of the Embroiderer's Art by Mrs. Archibald Christie. B. T. Batsford, London, and E. P. Dutton & Co., New York. Size 10 by $7\frac{1}{2}$ in.; 142 pages; 239 line illustrations in text and 34 halftone plates; price, 12 shillings net.

In this excellent treatise the author has, not only brought together the ornamental stitches that have been handed down thru the ages from mother to daughter, but she has described them in such detail that the needleworker can reproduce them by referring to the book. The stitches and the methods of making them have been collected from actual embroideries. They have been classified and presented to the reader by means of working diagrams which often show the several stages taken in making a stitch. The samplers suggest how the stitches may be applied.

Pasteless Paper Construction. By Miss S. E. E. Hammond. The Bruce Publishing Co., Milwaukee, 1921. Size $8\frac{1}{2} \times 5\frac{5}{8}$ in.; 48 pages; price, 60 cents.

This book gives a practical course in paper work for the primary grades. It is well worked out, simple, practical and well presented.

One Hundred Loose-Leaf Lessons in Lettering. By Wm. Hugh Gordon. Published by the Signs of the Times Publishing Co., Cincinnati, Ohio, 1920. Size 7 x 11 in.; illustrated; price \$2.00.

This publication consists of one hundred different lessons in lettering with pen and brush. A great number of different treatments of the alphabet is shown with sufficient explanations for most anyone to be able to attempt the reproductions. The music staff with its five lines and four spaces is used very effectively as guide lines for lower case letters.

These lessons should find favor with anyone who wishes to use lettering for sign painting, show card writing, or for other purpose where attractive and decorative lettering is required.

A Day in a Colonial Home. By Della R. Prescott. Edited by John Catton Dana. Published by Marshall Jones Company, Boston, 1921. Size 5 x $7\frac{1}{2}$ in.; 70 pages, illustrated with 27 line drawings and four half-tone plates; price, \$1.25.

This story was written for the purpose of making more real to children of the present generation the living conditions of colonial days—to help them to understand what came before the days of modern home equipment and conveniences.

LUMBER

JOSEPH H. DION, Pres & Treas
EDWIN C. SALVESEN, Secy.
F. FRED TAYLOR, Vice Pres

Maisey & Dion *Hardwood Lumber*



OFFICE AND YARDS,
2349 TO 2423 S. LOOMIS ST

TELEPHONES | CANAL 1830
| CANAL 1831
| CANAL 118

CHICAGO.

Dear Manual Training Supervisor:

Is lumber buying one of your WORRIES?

If so, why not eliminate the wear and tear on your nervous system by ordering from us?

During the past seventeen years we have taken care of an ever increasing number of schools to their complete satisfaction.

Our stock includes lumber of all kinds, grades and sizes to meet school needs.

No filling orders in a slipshod or haphazard manner in our institution.

Our yard superintendent exercises close supervision over the SEASONING, KILN DRYING, INSPECTING, MEASUREMENT, AND SHIPMENT of all orders. This insures you mighty good value.

We do not issue stock nor price list, each order is given individual attention. Please advise number of feet and kind of lumber wanted and we will gladly quote you.

Awaiting the opportunity of serving you, we remain,

Respectfully,

MAISEY & DION

J. H. Dion Pres.

MAISEY & DION — HARDWOOD LUMBER

2349 to 2423 South Loomis Street

CHICAGO

SIMONDS SAWS

For better and smoother work Manual Training and Vocational Schools use Simonds Saws. They are the best, but they cost no more than some inferior saws.

Simonds
Manufacturing Co.

"The Saw Makers"
Fitchburg, Mass. Chicago, Ill.
5 Factories 12 Branches

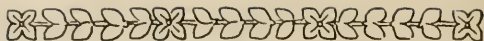

FIELD NOTES—(Continued)

MEETING OF THE VOCATIONAL EDUCATION SOCIETY OF BOSTON

The Vocational Education Society of Boston held its regular monthly meeting at Hotel Avery on Saturday, January 14, with George F. Hatch, the president, in the chair.

After an enjoyable luncheon the members took part in some community singing, after which a business meeting was held. At this time reports of committees were read and discussed, and several new instructors were elected to membership.

The Society has for some time been considering the advisability of becoming affiliated with the National Association for Vocational Education, and this matter was brought up for discussion at the meeting. Prof. John M. Brewer of Harvard College submitted various arguments in favor of affiliation with the national body, and President L. A. Wilson of the National Association for Vocational Education sent a letter in which he outlined the many advantages which would accrue to the Society by reason of such affiliation. After some discussion the matter was referred to the Committee on Education with instructions to report at the next meeting.

Hercules W. Geromanos, formerly Dean of Co-operative Courses of the Boston Young Men's Christian Association, who served as major with the Motor Transportation Corps of the American Expeditionary Forces, and who has just returned to this country after spending eighteen months in a trip around the world, gave a very interesting resume of some of his experiences, his talk being entitled "Some Interesting Views of my Trip Around the World." The speaker has taken a number of photographs on this trip from which some exceedingly interesting lantern slides had been prepared, and with these he illustrated various features of his talk which dealt at considerable length with the habits and customs of people in Canada, China, Japan, Java, India, New Zealand, Egypt, and many other European countries.

Mr. Geromanos stated that at present Germany is giving every evidence of having returned to normalcy in industry. He also exhibited some excellent specimens of handicraft collected during the trip. Prior to this trip Mr. Geromanos spent several years in the service of the United States government in connection with educational matters. It is his expressed belief that vocational education is yet in its infancy, and he predicts remarkable developments in vocational education within the next few years.

—FRANCIS L. BAIN.

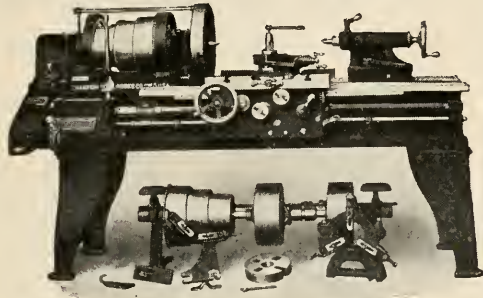

Champion Lathes

A quality engine lathe, accurate, convenient to operate and at a very attractive price to manual training and vocational schools.

Made in four sizes: 13", 15", 17" and 19"

Champion Tool Works

Winton Place

Cincinnati, Ohio

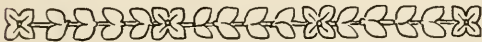

FIELD NOTES—(Continued)

PIONEER MACHINERY MANUFACTURER DEAD

Announcement has just been received of the death of Thomas P. Egan, aged 74 years, president of the world wide known concern of J. A. Fay & Egan Co., Cincinnati, Ohio, manufacturers of the "Lightning" Line Woodworking Machinery. Thomas Patrick Egan was a resident of Cincinnati nearly all his business life. He was born Nov. 20, 1847, in Limerick, Ireland, and when an infant was brought by his parents to Hamilton, Ontario. As a boy, after leaving school he was in the employ of dry goods houses in Hamilton and then in Detroit, but when 16 years old his mechanical bent led him to Cincinnati, where he secured a position in a machine shop. After a few months he changed to the firm of Steptoe, McFarlan & Co., which at that time was one of the heaviest manufacturers of woodworking machinery in the United States. He remained with them 12 years. Early in his employment with this firm he had the misfortune to lose an arm. Up to that time he had been engaged in the manual processes of the shop, but the accident sent him into the office where he studied

The Superiority of "CHAMPION" TOOL HOLDERS

Is the Patented Support

They last longer, will not break in taking heavy cuts or rapid work. The holder does not mash down.

It saves steel by allowing the cutter to be used up closer.

*Also a Complete Line of
"CHAMPION"*

Boring, Planer, Cut-Off, Turning,
Threading Tools, Mandrels,
Lathe Dogs (safety) Vises,
Power Hack Saws, Shop Furniture
High Speed Steels,
Both Square and Bevel Stock, etc.

"Tools of Quality"

SPECIAL PRICES TO SCHOOLS.

Ask for our Full Catalog

**WESTERN TOOL AND
MANUFACTURING CO.**

SPRINGFIELD

OHIO

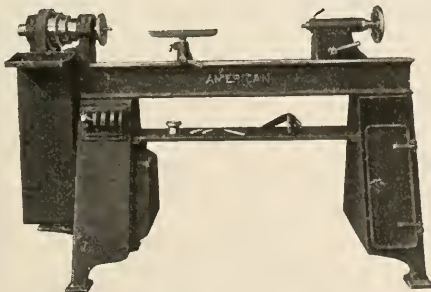

Manual Training Lathe with Motor
in Base—24" to 72" Centers

AMERICAN School Equipment

High Quality Machines
at Moderate Cost

SAW BENCHES
JOINTERS
PLANERS
BAND SAWS
WOODWORKERS

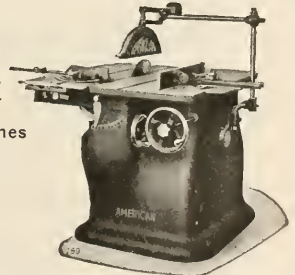

AMERICAN SAW MILL MACHINERY CO.

142 Main St., Hackettstown, N. J.

OUR NEW
CATALOG
OF
TOOLS
AND
BENCHES

WILL BE READY
IN A FEW WEEKS

We would like to register
your name for a copy.

Simply mention
Catalog No. 235

Since 1848 we have adhered to
one policy—to handle only
the very best in quality

**Hammacher
Schlemmer & Co.**

**Hardware, Tools and
Supplies**

**New York Since 1848
4th Ave. and 13th St.**

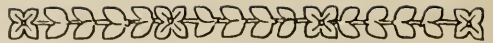

FIELD NOTES—(Continued)

bookkeeping and the technique of the business, which started him on his career of inventor, manager and employer.

In 1874 he decided to begin business on his own account and with two partners opened a little shop, where at first the partners constituted the entire force. Seven years afterward, however, in 1881, the Egan Co. was incorporated with a capital of \$150,000 with Thomas P. Egan, as its president. This enterprise was successful from the first. It was located across the street from the establishment of J. A. Fay & Co., then the most important woodworking machinery establishment in the country, and of which it became a rival. The commercial battle was a warm one, and finally resulted in the consolidation of the two companies in 1893 under the name of the J. A. Fay & Egan Co., of which also Mr. Egan was president. While busily engaged with the multitudinous affairs of his own business, Mr. Egan showed the spirit of a good citizen and was always ready to do his share in any movement for the advancement of the city or of his industry or the country. He was, for example, the organizer and first president of the National Association of Manufacturers, had promoted the export trade of the United States in machinery lines and was active in the citizens' organizations of his own city. He was elected president of the Cincinnati Chamber of Commerce in 1908.

ITEMS OF PROGRESS

A NEW MANUAL ARTS BUILDING

At the Tennessee Polytechnic Institute, Cookeville, Tennessee, a new manual arts building is now being finished which is claimed to be one of the most complete of its kind in the South. Machinery and equipment to the value of \$75,000 have been purchased and are ready for installment. Contracts covering the sum of \$100,000 have been awarded for other buildings to be erected at the same school during the coming year.

AT EVERETT, WASHINGTON

At the Kansas City meeting of the National Society for Vocational Education, an exhibit was made of plans for a seven room bungalow which was built last year by the vocational carpentry class in Everett, Washington. A large photograph showed the completed house with garage and woodshed in the background, all giving the impression of neat workmanship. According to the plan of Louis Jacobson, the teacher in charge of this class, two bungalows will be built this year. The car-

"JORGENSEN" PEERLESS HAND SCREWS

A single clamp will adjust to any of these positions or any modification of them.

Steel Spindles
Steel Nuts
Hard Maple Jaws

**Adjustable
Clamp Co.**

216 N. Jefferson St., Chicago

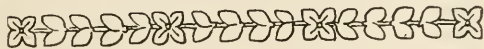
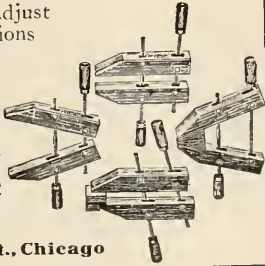

FIELD NOTES—(Continued)

pentry work, and the cement work on the foundation, are done by the students; the owner hires outside help for the other constructions. E. P. Fait is the vocational director of Everett.

INDUSTRIAL REHABILITATION IN ILLINOIS

The last session of the Illinois General Assembly appropriated \$125,000 for rehabilitation work for the biennium to match a like sum apportioned by the Federal Government. This \$250,000 is available for organizing and administering the work of discovering persons who are handicapped in some way or other and providing the training which will remove such handicap. These plans also provide for assisting such persons after their handicap is removed to find remunerative employment. The work is placed under the Illinois Board for Vocational Education. The Superintendent of Public Instruction is the executive officer of the board.

KILN DRYING COURSE FOR HOME STUDY

Since the announcement of the correspondence-study course "Kiln Drying of Lumber" by the Extension Division of the University of Wisconsin less than two years ago, almost 400 persons have

Marqueterie, Inlay Borders and Purflings for

Manufacturers and Vocational
Schools

Insets for Trays, Panels, Cabinets, etc., carried in stock.
Natural and Transformed Veneers in great variety.
Lines in Holly, Satinwood, Box, Mahogany and Black

J. BERNARD CO.

422 to 30 East 53rd St. New York

Prang-

*The standard in school
water colors*

THE story of the development of water color work in the schools is largely the story of Prang School Water Colors.

Sixty-six years ago Louis Prang produced the first satisfactory and inexpensive box of school water colors. The name Prang at once became the symbol of all that was finest in school water colors.

That it remains so today is attested by the fact that school boards of the large cities are specifying "Prang or equal."

Containing from ten to twenty per cent more color pigment than any others, these colors never fail to blend splendidly, making smooth and uniform washes.

If you would prove the statements of some of America's leading color experts, that "there have never been any better school water colors than those of Prang," we will gladly send you a trial box.

THE AMERICAN CRAYON CO.

Established 1835

SANDUSKY, OHIO NEW YORK



THE LIGHT RUNNING TANNEWITZ TYPE "G"

is cutting costs and increasing production in many high grade establishments because of its special improvements.

Solid And Durable.

Frame is an extra large one-piece casting giving extreme rigidity and long life.

Light Running. Aluminum rim wheels, with steel spokes, and ball bearings if desired.

Tilting Table Heavily Ribbed. Adjusts 45 degrees to right, and 5 degrees to left on dovetailed hinges, adjustable for wear.

Wide Range. 37" cutting point to frame and 18" under guide.

Well Protected. Swing- ing wire cage covers upper wheel. Metal doors over lower, giving easy accessibility. Lower wheel equipped with refuse guards. Automatic spring tensioning device prevents breakage of smallest blade.

*Write for our special bulletin
—free for the asking.*

The Tannewitz Works

304 Front Avenue, N. W.
GRAND RAPIDS, MICHIGAN

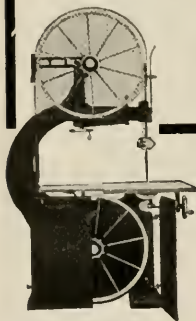

Type "G" Band Saw can be supplied with either motor or belt drive. We can adapt any of our machines to meet your special needs. Write us.

No More Loose Handles

Don't take chances with Hammers with ordinary Wedges when you can now secure the **UNCLE SAM BRAND** Hammers with the new **VAUGHAN'S EXPANSION WEDGE**.



If the handle shows any tendency to become loose simply set the Wedge (B) a notch or two deeper between the pins (A) and a tight handle is assured.

UNCLE SAM HAMMERS are the only Hammers that have been approved by the **UNDERWRITERS' LABORATORIES** and each Hammer has the Underwriters' Label. It took 900 lbs. more pressure to pull the handle through the head with the **VAUGHAN'S EXPANSION WEDGE** than with the Ordinary Wedge. Uncle Sam Hammers are made in all patterns and sizes. *Write for description booklet No. 10 which describes this line in detail.*

VAUGHAN & BUSHNELL MFG. CO.

2114
Carroll
Ave.



Chicago,
U. S. A.

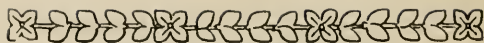

FIELD NOTES—(Continued)

enrolled. This course has been developed thru co-operation of the U. S. Forest Products Laboratory. Men from thirty-seven states of the Union and seven foreign countries have taken up this mail instruction to learn more about the art of operating dry kilns, and the proper handling of lumber in general.

The course consists of ten assignments prepared in a systematic way, taking up the subjects from the structure of wood, its moisture content, shrinking and case hardening, on thru a discussion of the various types of kilns, heat, humidity, circulation, and the operation of kilns. Drying schedules for all of the more common kinds of wood are included.

INDUSTRIAL ARTS MEETING IN SOUTH DAKOTA

The South Dakota Industrial Arts Association held its annual meeting November 21-22 at Huron, South Dakota.

The officers of the association for the coming year are: President, W. M. Phares, Madison; Vice-President, R. F. Grose, Watertown; Secretary and Treasurer, S. R. Harding, Aberdeen.

A resolution was submitted to the committee on the revision of the State Course of Study urging that four years of high-school credit be given for industrial arts and manual training work. Two years only are now allowed in the state of South Dakota.

OREGON INDUSTRIAL ARTS CONVENTION

The Division of Industrial Arts of the Oregon State Teachers' Association met at the Lincoln High School on Friday, December 30 with A. R. Nichols, state supervisor of trades and industries, as chairman. The principal topics for discussion were "Teaching Mechanical Drawing in the High Schools," "Auto-Mechanics as a Manual Training Subject," "The School Man in The Commercial

Cushions, Spring Seats Upholstering Supplies

We issue price list which also contains valuable information for Instructors in Manual Arts.

It is free—write for it.

DODGE-DICKINSON CO.
Bloomington, Illinois

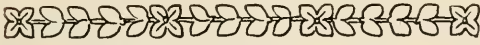

FIELD NOTES—(Continued)

Shop" and "A Course in Household Mechanics for Eighth Grade Pupils."

The men who were scheduled to speak on these topics respectively are: C. E. Platts, The Dalles; E. E. Bergeman, Salem; Darwin G. Thayer, Oregon Agricultural College; and Fred M. Groshong, Portland. Open discussions after each of these talks added much to the value of the program.

FROM AUBURN, MAINE

A report made by Frederick J. Bryant, supervisor of manual arts, Auburn, Maine, to the school board, shows that sixteen new drawing tables were made by the manual arts classes last year and are now in use in the schools. The expense of these tables was \$300 less than the marked price. A wood finishing room has been fitted up so that staining and varnishing can be done successfully. Printing is offered in the Auburn public schools and the classes turn out all the school printing. Stage scenery for the school entertainments has also been constructed by the manual arts students.

MILWAUKEE A LEADER IN VOCATIONAL ATTENDANCE

Thirty-six per cent of all vocational school pupils in the state of Wisconsin attend school in Mil-

CUSHIONS

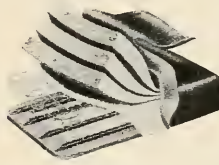

**Stuffed Cushions
Spring Cushions
Upholstery
Supplies**

*Write for Descriptive
Circular and Complete
Information for ordering*

Illinois Valley Awning and Tent Co.

Formerly Kunkle-Karl Co.

102 S. Washington St.

Peoria, Ill.

Give Your Pupils SHOP-WORK THAT PAYS

Let the Boys Build Phonographs

Imagine the pride and joy of your pupils in building *their own phonographs* (equal in quality to high-priced standard machines) either to sell or take home as a source of lasting pleasure. Think how this project will add to your popularity as an instructor. Building phonographs is easy, by our methods, yet it demands precision and delicacy of workmanship, the very points always emphasized in shop practice.

Send 10c for fine illustrated catalog

and full information about our co-operative plan for manual training teachers. We plan the work for you. We supply blueprints, tone-arms, motors, case material and all accessories at lowest prices. Detailed instructions furnished. Materials best obtainable, fully guaranteed. Our machines play any make record. Write us TODAY.

HOOSIER MANUFACTURING & SUPPLY CO.

PHONOGRAPH SUPPLY DEPT.

315 Baldwin Block, Dept. A.

Indianapolis, Ind.

A good Course can be taught best with good lathes

SIDNEY

ENGINE LATHES

Meet school requirements

Complete with all modern
Features and Equipments



GEARED HEAD

10" to 36" Swing

We Manufacture a Complete Line of

WOODWORKING MACHINERY

Including the "FAMOUS 30" UNIVERSAL WOODWORKER

Write for Interesting Descriptive Matter

THE SIDNEY MACHINE TOOL CO. SIDNEY, OHIO

The Student Needs Printing

as much as he needs the alphabet

Q It is as much a part of Education as English, the Rule of Three and History. It is, in fact, a combination of all studies—a practical illustration of all the student learns from teachers and books. It is at once a science, an art and an occupation. It gives him manual, mental and moral training. It helps him form habits of industry, accuracy and taste. It is a joy to the learner and a splendid asset in every relation of life.

Q We supply printing outfits for schools, and give the benefit of our experience and that of schools which have tried out the plan. No school is complete and doing its best work, or near its best work, unless printing is a part of its equipment.

Q Send to us for help in your problem.



Barnhart Brothers & Spindler

Type Founders

Chicago Washington, D. C. Dallas Saint Louis
Kansas City Omaha Saint Paul Seattle

SAW TABLES

For Manual Training

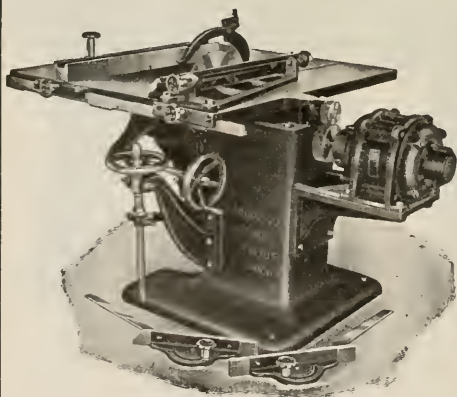

This cut shows our motor driven spiral gear saw table. No countshaft, no belts. Tilting or stationary tops. Write for circular and prices on our entire line. *Address*

ALEXANDER DODDS CO.

451-453 Monroe Ave., N. W.

GRAND RAPIDS, MICHIGAN, U. S. A.

In Gt. Britain: OLIVER MACHINERY Co., Manchester, Eng.

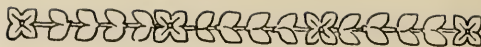

FIELD NOTES --(Continued)

waukee. In the whole state there are 47,985 vocational students. Milwaukee has 17,266 of these. Out of this number 1,443 attend day classes and 5,823 go to night schools. A well developed vocational program in this city under splendid leadership and administration has made this type of training attractive to the people of Milwaukee.

PENSACOLA, FLORIDA ORGANIZES PART-TIME CLASSES

Part-time classes have been organized in Pensacola, Florida, thru the advice of L. S. Green, state supervisor of trade and industrial education. These classes will demand the attendance of all boys over 14 years who have entered industry. The school will call for 144 hours of instruction during the year.

NEW HIGH SCHOOL AT ST. JOHNS, OREGON

Construction has begun on a new high school building at St. Johns, Oregon. The estimated cost of the building is \$240,000. The complete plans call for the erection of four detached buildings, each 50 x 100 feet. One of these will be used by the manual training department and one by the home economics department.

NATIONAL SOCIETY ELECTS NEW MEMBERS OF EXECUTIVE COMMITTEE

The following nine persons have been elected members of the Executive Committee of the National Society for Vocational Education for the ensuing year:

Norris A. Brisco, Director New York University, School of Retailing, New York, N. Y.

Lewis H. Carris, National Committee for Prevention of Blindness, New York, N. Y.

C. R. Dooley, Standard Oil Company, New York, N. Y.

Build Your Own PHONOGRAPH

Instructive—arouses pupils' enthusiasm—provides one of the best problems in cabinet making.

Let Your Pupils Build
Choraleon Phonographs

We furnish plans, blue prints, motors, tone arms, case material—in fact, everything required. Full instructions. Choraleon's have fine tone. Play any record. Ask for particulars.

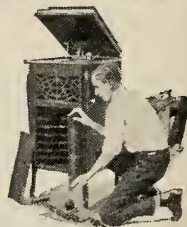

CHORALEON PHONOGRAPH CO.
322-7th St., Elkhart, Ind.

“GLUEY”

“The Perfect Paste”
now used in many
MANUAL TRAINING DEPTS.
in place of hot glue

Clean—Economical—Sticks

GLUEY spreads readily and is always
ready for instant use all ways

Send 10c for full size No. 4 Tube

THE COMMERCIAL PASTE CO.
COLUMBUS, OHIO

Our New Price List Is Out

It has been greatly extended.
No matter where you are lo-
cated there will be something
you must need, either in lum-
ber, panels or veneers.

*If you have not received copy
write us at once.*

Frank Paxton Lumber Co.
Kansas City, Kansas

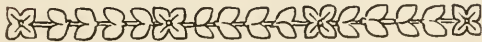

FIELD NOTES—(Continued)

Hugh Frayne, American Federation of Labor,
New York, N. Y.

Louis Moore, Dutchess Manufacturing Company,
Poughkeepsie, N. Y.

Iris Prouty O'Leary, State Department of Public
Instruction, Trenton, N. J.

C. R. Richards, Cooper Union, New York, N. Y.

David Snedden, Teachers College, New York,
N. Y.

George A. Works, N. Y. State College of Agri-
culture, Ithaca, N. Y.

ANNUAL EXHIBIT OF EVENING WORK AT PRATT INSTITUTE

Thursday evening, March 9, will be observed as
“Visitors' Night” in the School of Science and
Technology of Pratt Institute, Brooklyn. From
7:30 to 9:30 o'clock all the shops, laboratories and
drawing rooms of the School will be open to the
public.

This will be the only public exhibition of the work
of the Evening School this year.

VENUS PENCILS

SUPERBLY smooth and satiny,
VENUS best meets every pen-
cil purpose. For the instructor
or art student there is no pencil so
helpful and satisfactory.

17 perfect black degrees.

For bold, heavy lines . 6B-5B-4B-3B

For writing, sketching 2B-B-HB-F-H

For clean, fine lines, 2H-3H-4H-5H-6H

For delicate, thin lines . 7H-8H-9H

Plain Ends, per doz. \$1.00

Rubber Ends, per doz., 1.20



*The largest selling
Quality pencil in
the world'*

*At Stationers and Stores
throughout the World*

American Lead Pencil Co.
219 Fifth Ave., Dept. A., N. Y.
also London, Eng.

MAYDOLE HAMMERS

THE WORLD'S STANDARD

Highest Quality Steel Handled Hammers
Guaranteed First-Class in Every Respect

*Booklet of Useful Information
for each student on request.*

The David Maydole Hammer Co.
Norwich, N. Y., U. S. A.



Hard-To-Get Materials

This is the Line you have
been looking for

Unusual Cabinet Hardware
Chest Trimmings
Upholstery Supplies
Cushions
Mirrors

Catalog to Instructors

Thurston Manual Training Supply Co.
Jobbers and Manufacturers
ANOKA, MINNESOTA

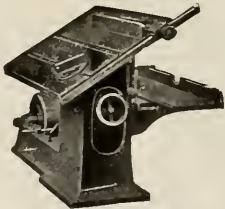

Crescent Wood Working Machines

are the tools your students will eventually use so give them the opportunity now of learning about this splendid line of wood working machinery.

Send today for our catalog of band saws, jointers, saw table, shapers, variety wood workers, planers, planers and matchers, cut off saws, disk grinders, borers, hollow chisel mortisers, Universal wood workers.

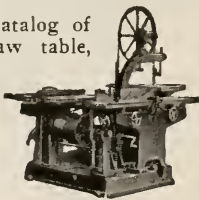

The Crescent Machine Co.

46 CHERRY ST.

LEETONIA, OHIO

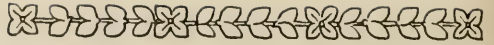

TRADE NOTES

MOTION PICTURE FILM FOR THE
VOCATIONAL MACHINE SHOP

A seven-reel motion picture film which is designed for use as an aid in teaching vocational machine shop practice has been made by the Society for Visual Education, of Chicago. The picture, which is entitled "The Engine Lathe, Its Care and Operations" was taken in the plant of the South Bend Lathe Works under the supervision of experts both in the fields of education and motion picture production.

A committee which made a complete trade analysis of engine lathe operations, selected over two hundred as being most fundamental and valuable ones to demonstrate. These operations were then performed by an expert machinist who carried them thru according to the best standard practice while the camera recorded each movement for reproduction on the screen.

Instructors of machine shop work will find this film to be of great assistance in creating a general interest in the work, in showing the possibilities of the use of the lathe, and in giving actual shop demonstrations to large numbers of students at one time. The picture contains no advertising of any sort. A synopsis of the picture can be obtained free of charge by writing the Society for Visual Education, 806 W. Washington Blvd., Chicago.

NEW BRANCH OF OLIVER MACHINERY CO.

IN order to be of greater assistance to teachers of manual training in the schools in the Northwest the Oliver Machinery Company of Grand Rapids, Michigan, well-known manufacturers of woodworking machinery, have just opened a branch office in Minneapolis. It is located at 716 Lincoln Bank Building, and is known as the Oliver Machinery Company. The territory in the jurisdiction of this branch office includes Western Wisconsin, Min-

L-U-M-B-E-R

We Specialize in
Manual Training Lumber

No order is too large or too small to receive
our careful attention

John S. Benedict Lumber Co.
419 N. Halsted St. CHICAGO



WE ARE GENERAL AGENTS FOR THE WORLD
FAMOUS GENUINE RICHTER

DRAWING INSTRUMENTS

They represent the highest standard in quality
and have no equal anywhere.

Write and give requirements.

*Complete circular showing sets and separate tools
mailed on request.*

U. S. BLUE PRINT PAPER CO.
CHICAGO, ILLINOIS

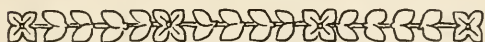

TRADE NOTES—(Continued)

nesota, North and South Dakota, Nebraska and
Western Iowa.

The manager of this office is Mr. George C.
Ramer, a practical man who has had considerable
experience in fitting up and equipping manual training
schools and institutions as well as many industrial shops.

NEW FACTORY

S. C. Johnson & Son, Racine, Wis., have recently
opened a new factory in West Drayton, Middlesex,
England, the firm name of which is S. C. Johnson
& Son, Ltd. Mr. A. B. Carey, who has been with
the domestic firm for nearly 20 years is resident
manager of the new firm. This is a private Company,
registered Nov. 14th, 1921. The capital is
L75,000, (\$375,000.00). The entire line of Johnson's
Artistic Wood Finishes will hereafter be manufactured
in West Drayton. This line includes Johnson's Prepared
Wax, Wood Dye, Floor Varnish, Sani-Spar Varnish,
Perfectone Undercoat and Enamel, Crack Filler,
Paste Wood Filler, Electric Solvo, Varnish Remover,
etc. The English Factory is completely equipped and
the Sales Force thoroly organized.

SIMPLIFY GRINDING

With Mummert-Dixon Oilstone Grinders. Five wheels for almost every class of grinding. They accomplish the work quickly and accurately. With this machine your students can experience the pleasure of sharp tools.



The Modern
Edge Tool
Sharpening
Machines.

The
Standard
for all
Industrial
Schools

Five
Leading
Features
Coarse Oilstone
Wheel
Fine Oilstone
Wheel
Emery Wheel
Grinder
Cone
Leather
Wheel

Furnished for motor drive or with counter-shaft
Send for full descriptive bulletin

MUMMERT-DIXON CO., Hanover, Pa.

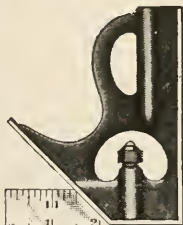

NEW LUFKIN "UNIVERSAL"
TRY AND MITRE
SQUARES
FOR WOODWORKERS
HIGH GRADE YET POPULAR PRICED
ACCURATE—DURABLE—WELL DESIGNED
No. 65L—WITH LEVEL No. 65—WITHOUT LEVEL

Made in 9-inch and
12-inch lengths

Distinct marking; movable yet secure head. Serves also as marking, height and depth gauge,
level and plumb, and separate rule. *If Unobtainable at Dealers Write Us Direct.*

Send for Catalogue

THE LUFKIN RULE CO.

SAGINAW, MICH.
New York



CLASSIFIED ADVERTISEMENTS



Do you want to sell or want to buy some school shop supplies? Do you want to employ a teacher? Do you want a new position? Advertise your wants in these classified columns. Rate 20c a line, minimum \$1.00.

ELECTRICAL PROJECTS

BUILD "PEPCO" ELECTRIC TOASTERS—A useful and attractive project. Buy the parts from the Practical Electrical Project Co., Highland Park, Illinois.

BLUE PRINTS

FREE CATALOG AND SAMPLE—Blue Prints of Agricultural, Furniture Making, Mechanical Drawing, Wood Turning, Forge Work, Pattern Making and Whittling Problems. Make your work more practical. Work from blue prints. Schenke Blue Print Co., 1034 Carney Blvd., Marinette, Wis.

GRANDFATHER'S CLOCK—Blue prints, finishing material and instructions. Also works, dial, weights and pendulum can be purchased from us at surprisingly low prices. Send for particulars of our attractive offer. Clock Company, 1666 Ruffner St., Philadelphia, Pa.

METAL WORKING SUPPLIES

DO YOU TEACH METAL WORK—The education a value of metal construction and metal working is unquestioned. The practical instruction is far superior to wood working. Art and Manual Training easily coordinate in metal work. We have almost all the supplies required and are trying to bring about pre-war prices. Send for our catalog. Lewis & Co., Capitol Station, Box 16, Albany, N. Y.

MANUAL TRAINING LUMBER

YOU CAN SAVE MONEY AND TIME by buying OAK SQUARES and ASH SQUARES in Clear lumber, one to two inches thick and from 15 to 40 inches long. We also specialize in Cedar Chest lumber, Philippine and other Mahoganies. FRANK PAXTON LUMBER CO., KANSAS CITY, KANSAS.

AMERICAN WALNUT LUMBER—We carry a stock of over two million feet of Walnut Lumber, consisting of all grades and thicknesses from $\frac{1}{2}$ " to 4". Due to this large stock we are always in position to supply dry lumber for Manual Training use. Send us your inquiries. Frank Purcell Walnut Lumber Company, 12th Street & Belt Line, Kansas City, Kansas.

AROMATIC TENN. RED CEDAR BOARDS. Small shipments a specialty. Write us for prices delivered at your railroad station. Earthman Lumber Co., Murfreesboro, Tenn.

MORGAN MANUAL TRAINING MATERIALS—A perfect system of dry kiln enables us to give you lumber thoroughly dry. Carrying in stock large quantities of different woods permits us to fill your orders with the best selections. Write, sending us a list of the materials you desire. We will quote you attractive prices. Morgan Company, Oshkosh, Wisconsin.

LUMBER—Maisey & Dion, 2349 to 2423 South Loomis St., Chicago, Illinois, carry in stock a large and diversified stock of MANUAL TRAINING LUMBER. Fifteen years' experience with schools enables us to fill such orders satisfactorily.

MISCELLANEOUS

WOODEN MULTIPLEX PLIERS. One piece of wood containing seven pliers; made by means of a knife; length, four inches; an interesting piece of wood-work. Sent post-paid for one dollar; remit by P. O. order. Address, Museum of Wood, Ingleside, Nebraska.

FURNITURE HARDWARE

FURNITURE HARDWARE AND UPHOLSTERY SUPPLIES for Manual Training. Drawer pulls, costumer hooks, wood knobs, box fittings, tea wagon wheels, electric cluster posts, cedar chest locks, handles, hinges, etc., mirrors, wood dooies, Seng bed equipment, Stanley Tools. Send for Catalog, Ohio Vocational Supply Co., Wapakoneta, O.

BASKETRY

BASKETRY MATERIALS. Reeds, raffia, wooden bases, chair cane, Indian ash, splints, cane webbing, wooden beads, braided straw, rush, willow, pine needles, books, tools, dyes. Catalogue and Directions, 15 cents. Louis Stoughton Drake, Inc., 34 Everett St., Allston, Station 34, Boston, Mass.

PINE NEEDLES FOR BASKETRY. Brown and green, in tied bunches, 30 cents lb. cash, 35 cents lb. credit (not including postage in either case). Tiny cones 15 cents dozen. Large cones 5 cents each. Florence Williamson, Laurel, Mississippi.

REED FOUNDATIONS AND SUPPLIES. Veneered tray bottoms, clear pine bottoms, lamp standards and fixtures, galvanized iron containers, finishing materials, etc. Send for catalogue. The Kessel and Nyhus Co., 910 Westminster St., St. Paul, Minn.

COILED BASKET MAKING is completely treated in the teacher's manual by Marten entitled *Inexpensive Basketry*. It outlines a course for grades three to six, accompanied by a series of excellent photographs showing every process. Price 45 cents. The Manual Arts Press, Peoria, Ill.

ELEMENTARY HANDWORK

TAWIDO LOOMS with four treadles weave from 12" to 20" widths. Desk and Table Looms, 6" to 12". Tapestry loom 34". Shuttles, Yarnwinders, Warp Frames. Instruction in pattern weaving and tapestries. Elma M. De Neergaard, Tawido Looms Studio, 23 Union Square West, New York, N. Y.

EVERYTHING FOR ELEMENTARY HANDWORK—Also for basketry, weaving, bookbinding and chair caning. Mounting boards, Waldcraft dyes, crayons, burlap, scissors, punch and eye sets. Thomas Charles Co., 2249 Calumet Ave., Chicago.

SCHOOL SHOP SUPPLIES

SODERING SUPPLIES, including the famous Allen Non-Acid Sodering Fluxes—in stick, paste, salts and liquid form; handy soder sets, sodering tools, aluminum soder and flux. As pioneers in the development of fluxes that far surpass muriatic acid, in every way, and as the original exponents of non-acid fluxes, the House of Allen has for 25 years maintained a position of leadership in the Arts and Crafts concerned with sodering. Send for our Bulletins L. B. Allen Co. Inc., 4584 N. Lincoln St., Chicago, Ill.

ANNOUNCEMENTS

IT IS NOW POSSIBLE for you to secure the parts necessary to build electric toasters. Write today for circular and price list to the Practical Electrical Projects Co., Highland Park, Illinois.

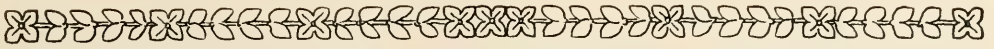

BOOK NOTES

IN a short time—probably early in April—The Manual Arts Press will publish a book of *Working Drawings of Colonial Furniture* by Frederick J. Bryant of Auburn, Maine. So far as we know, Mr. Bryant is the first man to make a study of the simpler pieces of the famous old examples of household furniture and prepare carefully-figured working drawings for students and amateurs. By making use of these drawings it is possible for students to reproduce some of the fine pieces made by the early followers of Chippendale, Hepplewhite and Sheraton. In this collection only such examples are given as can be successfully worked out by students of the high schools and vocational schools. In other words, the very large and complex pieces have been omitted. One may be certain, however, that the original style has been kept, for the author says that nothing has been added to or subtracted from the original measurements.

This collection of working drawings includes several fine old tables and equally good chairs, tall clocks, short clocks, and looking-glasses. If faithfully reproduced, these designs will add beauty and comfort to many homes. Every single one of the pieces is a worth-while project for the school workshop.

AMONG the new books announced by the manual Arts Press the latest to appear is *School Shop Installation and Maintenance* by L. S. Greene, professor of industrial education, University of Florida and state supervisor of industrial education for Florida. This book has just come from the bindery. It covers a new field. It is a book on the engineering side of shop equipments. It is a textbook for teacher-training classes and a handbook for teachers who are in charge of shops. It is what many teachers have been looking for during past years but have never found it. It combines the knowledge of the mechanical engineer, the electrical engineer, the millwright and the shop teacher of experience, and focuses it upon school shop installation and maintenance problems.

Mr. Greene gives us this statement of how he came to write the book:

"While teaching in one of our larger universities, I was called upon to give a course that would deal with the shop installation and maintenance problems of the vocational and manual training teachers.

In organizing my material for instruction purposes, I had much trouble in getting just the information and data I wanted and in the form that I wished it. I had to refer to technical books, mechanical, electrical and engineering handbooks, mill-wrighting books, etc. Other information was

gained from literature of various machinery and tool manufacturers and from talks with experienced and practical mechanics. To this was added what notes I could furnish as a result of my own experiments and experiences. Realizing that there was bound to be a constant need for such information in the training of these teachers, I resolved to put in book form the information I had gained from my study, experiments and experiences and to illustrate such notes in a way to make them clear. As the work upon the book progressed I further realized that such material should also be of value to students in vocational classes, to apprentices, mechanics and particularly teachers of manual, industrial and vocational classes.

"The book is:

"1—A handbook for teachers of vocational and manual training classes.

"2—A handbook for the practical mechanic who wishes plainly written technical information concerning such matters as: (a) installation of shafting and machinery, with tables and rules for figuring speeds, horse-power, etc. (b) belts—their choice, use and care (c) the fitting of edge tools, hand, band and circular saws, etc. (d) babbiting bearings. (e) etc.

"3—A text for use in vocational teacher-training classes in normal schools and colleges.

"4—A book written because of the need of it. The information it contains is a compilation and cumulation of technical information, plainly and simply written, and of practical information the result of the author's own experiences and the experiences of those with whom he has come in first-hand contact.

WE ARE indebted to Francis L. Bain of Boston for the following review:

I have examined Mr. Klenke's recent book entitled *Art and Education in Wood-Turning*, and am pleased to note the evident desire of the author to attempt a wise combination of the fundamentals of constructive design with an interesting and commercially valuable branch of woodworking. Too often it is true that design does not receive its due emphasis in this direction, and because of that fact, opportunities have been lost to attach a greater educational value to such work.

The various processes involved, together with necessary instructions for the same are clearly indicated and are well amplified with illustrations which are well executed. A pleasing variety of articles has been selected, with a wide scope of usefulness indicated, and these conditions unite to make this book very desirable as a student's text.

**"OLIVER"
FORGE EQUIPMENT
CEDAR RAPIDS, IOWA.**

This is just one of many prominent forge shops equipped with "Oliver" Down Draft Forges, Blowers, Anvils, etc. Cast Iron Forges are the best kind to buy.

"Oliver" Down Draft Forges are convenient and economical to operate. They are easy to install. The forge pan and hood are made of heavy cast iron, also the water tank. Such forges far outlast light types.

The engineering features connected with the "layout" for a forge equipment should be



entrusted only to an expert along this line. Our Engineers are at your service for the asking. If interested write the

**Oliver Mach'y Co.
GRAND RAPIDS,
MICH.**



**FOR THE WELL EQUIPPED
MANUAL TRAINING SHOP**

PARKS Jewel

22-in. Band Saw

All Parks woodworking machines are built primarily for experienced carpenters and contractors. They are built to withstand hard usage under all conditions in the shop and on the job. Parks machines in the manual training shop improve student workmanship and hasten proficiency.

**PARKS Jewel
22-in. Band Saw**

\$70.00

Send for illustrated Catalog of Parks Woodworking Machines

The Parks Ball Bearing Machine Co.

1536-46 Knowlton St. Cincinnati, Ohio

Canadian Factory:

200 Notre Dame East, Montreal, Canada

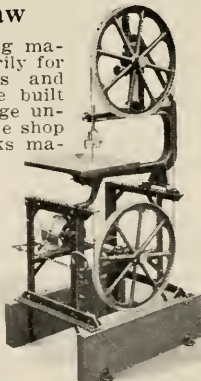

BEST QUALITY OF

DRAWING INSTRUMENTS

Consistent with prices within reach of every student

COMPLETE LINE OF

**T. Squares, Triangles, Scales,
Drawing Boards, Drawing Papers,
Pencils, Thumb Tacks, Etc.**

Ask for Illustrations and Prices

**THE OLD RELIABLE HOUSE
AMERICAN BLUE PRINT PAPER CO.**

445 Plymouth Court, Chicago, Ill.

PARKS

MANUAL TRAINING MAGAZINE

EDITORS CHARLES A. BENNETT, Peoria, Illinois.
WILLIAM T. BAWDEN, Assistant to Commissioner of Education Washington, D. C.

ASSOCIATE ARTHUR D. DEAN, Professor of Vocational Education, Teachers College, New York City.
EDITORS: FRANK M. LEAVITT, Associate Superintendent Public Schools, Pittsburgh, Pa.
WILLIAM E. ROBERTS, Supervisor of Manual Training, Public Schools, Cleveland, Ohio.

Business Manager: L. L. SIMPSON.

Published monthly by The Manual Arts Press, 237 N. Monroe St., Peoria, Illinois.

Subscription Price, \$1.50; Canada, \$1.80; Foreign, \$2.00. Single Copies, 25 cents; Foreign, 30 cents.

Subscriptions, remittances and manuscripts should be sent to THE MANUAL ARTS PRESS, Peoria, Illinois.

CONTENTS

THE PRESENT STATUS OF INDUSTRIAL ARTS EDUCATION IN OUR ELEMENTARY SCHOOLS.....	<i>A. H. Edgerton</i>	335
DESIGNING BIRD HOUSES FOR PARTICULAR OCCUPANTS (Illustrated).....	<i>Emanuel E. Ericson</i>	343
SUPERVISION OF MECHANIC ARTS.....	<i>Max Drucker</i>	346
PROJECT RECORD, THE.....	<i>W. Le Roy Benedict</i>	349
VOCATIONAL EDUCATION PROGRAM AT THE MEETING OF THE DEPARTMENT OF SUPERINTENDENCE.....	<i>Charles A. Bennett</i>	351
THE MILWAUKEE CONTINUATION SCHOOL (Photographs only).....		353
EDITORIAL REVIEW FOR THE MONTH.....	<i>Chas. A. Bennett</i>	356
A National Scheme of Organization of Vocational Teachers and Supervisors—The Origin of the Vocational Education Association of the Middle West—The Vocational Guidance Convention—The Personnel of Smith-Hughes Classes.		
A POINT OF VIEW.....	<i>Arthur Dean</i>	363
A Good Fellow, but—		
WASHINGTON CORRESPONDENCE.....	<i>William T. Bawden</i>	364
Public Duties of the Manual Training Teacher—Manual Training Ideals Are Basic Character Ideals.		
IN FOREIGN COUNTRIES.....		366
Differences of Opinion Concerning Industrial Education for India—The Cultural and the Industrial Value of Handwork—The Aim of Junior Technical Schools.		
PROJECTS, PROBLEMS AND NOTES.....		368
Exhibit of Machine Shop Work—Sewing Box—A Use for the Empty Chalk Box—A Drawing of Every Object?		
CURRENT PUBLICATIONS.....		372
FIELD NOTES.....		IV
From the Southwest—California Field Notes—Southeastern Items—Meeting of Voca- tional Education Society of Boston—Radiophone Construction in Chicago Schools— From Delaware and New Jersey—Around New York—Civil Service Commission Calls for Teachers—Western Arts Association Convention—Oklahoma Manual Arts Instruc- tors' Conference—From Minnesota—Items of Progress.		
TRADE NOTES.....		XXXI
BOOK NOTES.....		XLI

This Magazine is kept for sale at McClurg's in Chicago, and Brentano's in New York.

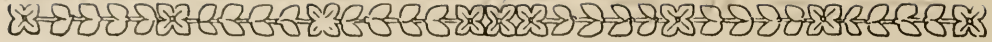

FIELD NOTES

FROM THE SOUTHWEST

KITE TOURNAMENT AT DALLAS

The Dallas City Schools have conducted a kite tournament open to boys and girls of both grades and high school. The tournament was planned to be held the latter part of March under the direction of the manual training teachers of the schools under the supervision of E. M. Wyatt, director of manual training.

The contests which were announced were so varied that no school boy or girl who wishes to enter was left out. The first meeting of the teachers was held the first week in March and details of the tournament were discussed.

There was competition for the largest kite, the smallest kite, the highest flying kite, the highest flying tandem, the most artistic kite, the most original design, a one-eighth mile kite dash, the best kite reel and best photograph taken from a kite. Every kite had to fly in order to be entered in the competition.

The artistic kite contest was under the direction of Miss Lida Hooe, supervisor of drawing in the schools. She advised the contestants regarding the best plans for the designs.

It was believed that some very good aerial photographs would be obtained thru the use of the special camera attachment to the kite line. A number of Dallas firms who have endorsed the tournament were expected to offer a number of prizes.

MEETING OF THE NORTH TEXAS VOCATIONAL TEACHERS' ASSOCIATION

The second meeting of the North Texas Vocational Teachers' Association was held at the North Texas Normal College, in Denton, February 18th, with the president, Hugo J. P. Vitz presiding. The first number on the program was an address of welcome. Following this Professor A. A. Miller, director of commercial arts in the North Texas Normal College, delivered an address on the subject of "Growth in Education." The topic, "The Special Supervisor," was presented by E. M. Wyatt, director of manual training in the Dallas public schools. Next Mr. Martin, of A. and M. College, discussed "The Tendency of Vocational Education at the Present Time."

Some time was devoted to visiting the laboratories of the Normal College, after which a luncheon was served. During this hour there were many short talks upon topics of interest to the members of the association.

The first part of the afternoon session was devoted to sectional meetings held in different buildings.

The following departments compose the Association: Industrial Arts, Agriculture, Applied Arts, Home Economics, and Commercial Arts. All department chairmen reported excellent meetings with good attendance. The next meeting will be held in Fort Worth next fall. The exact date will be announced by the president.

All schools west of the Pecos River in West Texas met at the Sul Ross Normal College located at Alpine on February third. At this meeting the Trans Pecos Division of the State Industrial Arts Association was organized. Harold Brenholtz of Alpine was elected president and O. A. Zimmerman of Ft. Stockton secretary. Meetings will be held annually.

—E. A. FUNKHOUSER.

CALIFORNIA FIELD NOTES

Reading the report of the recent annual convention of the National Society for Vocational Education as made by Mr. Ericson under the title "Outstanding features of National Society Convention" in the recent issue of *Manual Training Magazine* made me think that it might be well this time to write something about the industrial education and vocational training situation in Los Angeles. The report of Mr. Ericson points out that two outstanding subjects of discussion at the recent convention were (1) "the purpose of the organization and administration of part-time schools, and (2) the proper understanding and cooperation between vocational schools and the employers who are to use the human product turned out by these schools."

SHORT UNIT COURSES IN LOS ANGELES

Strange as it may seem, the Los Angeles school authorities long ago recognized the importance of these two issues, and have endeavored to make their schools grow in a direction designed to solve the above two problems. To this end they have laid special stress in the first place upon the development of short unit courses; and as far back as early in 1919 had established in their schools short unit courses in the following subjects: sheet metal work, vocational forge work, machine shop occupations, auto-construction and repair, auto-electrics, mechanical drafting, inside wiring, telephony, oxy-acetelene welding, and plumbing. Since there is just at this time widespread interest thruout the

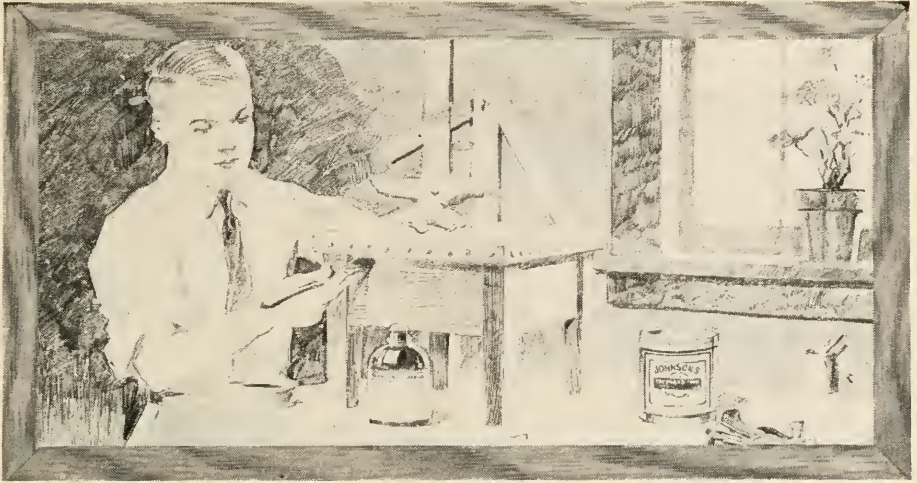

“Simply Stain It—Any Color— with Johnson’s Wood Dye”

JOHNSON’S Wood Dye is just the preparation for staining manual training models. It is very easy to use—goes on like oil without a lap or streak. It is made in thirteen attractive shades—which may be easily lightened and darkened. Complete instructions are given on every label.

JOHNSON’S ARTISTIC WOOD FINISHES

Johnson’s Artistic Wood Finishes are now being used in nine-tenths of the schools in the Country. They are particularly adapted for manual training work as they may be applied by the youngest and most inexperienced pupils with the best results.

The Johnson Wood Finishes most popular among Manual Training Instructors and Pupils are *Johnson’s Wood Dye, Prepared Wax, Under-Lac, Paste Wood Filler, Flat Varnish, PerfectTone Under-Coat and PerfectTone Enamel*. We have a very attractive exhibit of wood panels finished with these products which we are glad to send Manual Training Instructors who will give it wall space in their shop. Write for it.

Beautiful Instruction Book Free

Write for our beautiful new thirty-two page color booklet “The Proper Treatment for Floors, Wood-work and Furniture.” It is full of valuable information on artistic wood finishing. Do not hesitate to send for it. We will gladly furnish it upon request free and postpaid.

S. C. JOHNSON & SON, Dept. M.T.4, Racine, Wis.

“The Wood Finishing Authorities”
CANADIAN FACTORY—BRANTFORD



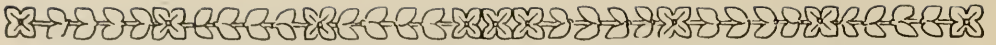

FIELD NOTES—(Continued)

country in the subject of auto-construction, it may be interesting to list the various units which are taken up in this course.

Unit 1. Practice shop work and lectures on frames and axles—14 lessons.

Unit 2. Practical shopwork and lectures on transmissions, clutches, and steering gears—10 lessons.

Unit 3. Practical shopwork and lectures on gas engines, lubrication and cooling systems—20 lessons.

Unit 4. Practical shopwork and lectures on carburetors—10 lessons.

Unit 5. Laboratory testing and experimenting on gas engines—10 lessons.

Unit 6. Sketching, plan reading, and mathematics of the automobile—6 lessons.

Unit 7. Laboratory testing and experimenting on lubrication—5 lessons.

Unit 8. Laboratory testing and experimenting on chassis—5 lessons.

AN OUTLINE OF LESSONS IN SHORT UNIT COURSE

By way of illustration, here is an outline of the various lessons embraced in Unit 3. "Practical shop work and lectures on gas engines, lubrication, and cooling systems."

Lesson 1. Oral instructions: cycle of operations and general theory underlying the operation of gasoline and gas engines.

Lesson 2. Oral instructions: Types of different gas engines, advantages and disadvantages of each.

Lesson 3. Inspect and test crank shaft for straightness, static balance, roundness and taper of pins and journals.

Lesson 4. Fit connecting rod to crank shaft, using bearing scrapers.

Lesson 5. Fit crank shaft to crank case or engine base bearings, using bearing scrapers.

Lesson 6. Inspect and test cylinder bore for smoothness, roundness and taper.

Lesson 7. Inspect valve guides for fit to stems, and valve seats for smoothness and width.

Lesson 8. Inspect pistons and rings, smoothness of piston; clearance in cylinder; fit of piston pin; fit of rings in grooves. Fit new rings in cylinder.

Lesson 9. Inspect, test and fit valve gear and valves. Test cam shaft for straightness and wear on cam or journals.

Lesson 10. Set (or time) valves without reference to marks on gears or flywheels and then check with marks. Set by piston position as well as by angle. Check clearance between tappet or rocker arm and valve stem.

Lesson 11. Disassemble water pump. Polish shaft. Test shaft for straightness and fit of coup-

ling or gears and of paddle. Fit pin to paddle wheel. Repack with graphite coated packing.

Lesson 12. Disassemble one of the several types of gas engines. Overhaul thoroly, assemble and test.

Lesson 13. Remove the carbon from the cylinders of a gas engine by use of oxygen process or scrapers.

Lesson 14. Inspect, grind and adjust the valves of an L-head or a T-head engine.

Lesson 15. Inspect and fit engine bearings without removing the engine from the frame.

Lesson 16. Practice tuning up and locating engine trouble. This practice should be given until students are competent to quickly locate causes of engine failure or of unsatisfactory engine performance.

Lesson 17. Oral instructions: Condition of surfaces and duty which lubricant must perform. Properties of lubricant. Types of oiling systems and causes of imperfect lubrication.

Lesson 18. Drain and flush engine oiling system. Remove and clean oil filter screen or screen and pump.

Lesson 19. Wash out crank case. Blow out all pipes with pressure. Disassemble oil pump and clean.

Lesson 20. Drain, wash out and refill transmission and differential cases with proper lubricant to correct level.

VOCATIONAL TRAINING COURSES

So much for the short unit courses, which have been developed in the Los Angeles schools. They have, however, not stopped with these courses, but are offering many distinctly vocational training courses. Here are some of the courses:

1) Automobile electrical, which includes the occupations of ignition work, electrical engineering, storage battery building and repair, and stage electrical work.

2) Auto-mechanics, which embraces occupations leading to automobile repairing, automobile demonstrating, auto salesmanship, automotive engineering and general mechanics.

3) Machine shop which takes in the occupations of machinist, master mechanic, tool room expert, machine shop foreman, locomotive machinist, and auto machinist.

4) Forging, which embraces blacksmithing, drop forging, heat treating, and oxy-acetylene welding.

5) Trade and commercial art, division of vocations, including such occupations as jewelry design, various phases of commercial art, figure drawing, cartooning, interior decorating, and designing.

LITTLE GIANT

MANUAL TRAINING DEPARTMENT

Special Equipment

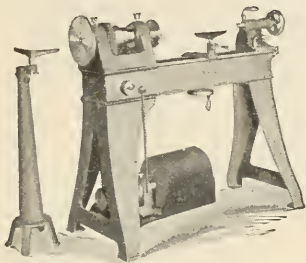

LITTLE GIANT WOOD LATHES

Individual Motor Driven, or Belt Driven from above or beneath.

Furnished with either Bench or Floor Legs. Wide choice of optional tools and equipment. Four speeds.

Many new, exclusive and practical features. All bearings are Hyatt High Duty Roller Bearings which greatly reduce power required. Ball Thrust bearings at all points of end thrust.

Sold on 30 days trial, and **GUARANTEED FOREVER** against defective material and workmanship.

LITTLE GIANT METAL LATHES

Individual Motor Driven, or Belt Driven from above or beneath.

Furnished with either Bench or Floor Legs. Wide choice of optional equipment. Three speeds.

Many new, exclusive and practical features are also found on our metal lathes. They are fitted to receive attachments for grinding, milling, gear cutting, etc., all of which we will furnish at a small fraction of the cost of a separate machine for such work.

Sold on 30 days trial and **GUARANTEED FOREVER** against defective material and workmanship.

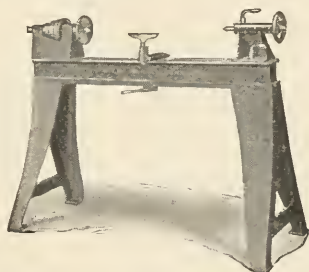

LITTLE GIANT POWER HAMMERS

Individual Motor Driven, or Belt Driven from above. Hundreds of different form-forging dies for instruction purposes.

Standard equipment with leading Technical and Manual Training Institutions.

Sold on 30 days trial, and **GUARANTEED FOREVER** against defective material and workmanship.



DO NOT OVERLOOK

Metal Working Equipment in your school. Wood can never be made anything else, while metal working and alloying are in their infancy.

The Industrial Leaders of the world, to a very large extent, began as metal workers.

Wood working is artistic, and trains mind, eye and hand to deftness. Metal working does all this, and more. It is also practical, and the graduate invariably finds a position waiting for him, while the wood working department graduate usually takes up something else and his instruction is forgotten.

Little Giant Equipment for Technical and Manual Training Schools consists of a full line of all metal and wood working machinery including accessories and tools for same.

On Motor Driven Equipment, information will be required as to Current, Voltage, Phase and Cycles of Motor.

Our business commenced in January, 1876, more than 45 years ago, and our Little Giant Products are used throughout the world. We are anxious to serve you for we can do it well.

Quotations and descriptive literature can be secured from any jobber, or direct from us.



LITTLE GIANT COMPANY

220 ROCK ST.

MANKATO, MINN., U. S. A.



FIELD NOTES—(Continued)

6) Architecture, which embraces buying and selling of furniture and furnishings, contracting in all forms, designing of buildings, gardens, furniture, furnishings, electrical fixtures, etc., and structural engineering as applied to buildings.

7) Mechanical Drawing includes detailing and tracing, machine designing, mechanical drafting, structural drafting, and tool designing.

8) Sheet-metal work takes in the occupations of tin smithing, plate working, light tank building, auto-body work, radiator building and copper smithing.

9) Printing embraces the occupations of hand composition, linotype operating, monotype operating, stereotyping, press feeding, and photo engraving.

10) Pattern making includes wood pattern-making, metal pattern-making, mill working, pattern designing, and furniture making.

11) Foundry embraces general foundry work, cupola tending, foundry foreman, and core making.

12) Electric wiring includes the occupations of housewiring, general electrical work and auto-electrics.

13) Advanced electricity embraces plant electrician, electrical repairing, armature winding, electrical engineering, battery building, and substation operating.

14) Woodwork includes furniture and cabinet making, skilled carpentry, interior finish, mill working, contracting, and building.

There are other vocational courses given such as oil and sugar operation, and industrial chemistry, which have not been listed in these notes.

—CHAS. L. JACOBS.

SOUTHEASTERN ITEMS

The idea of going into a section of country strictly rural, rough and broken, with parts quite isolated, might seem very unattractive to people who were brought up surrounded by the whirling wheels of industry.

Ten years ago when W. C. Wilson, already a veteran in industrial work, left Ohio in response to a call for east Tennessee, he helped to carry a good message and started a great work among the people of that section. Has the effort been worth while? The results speak for themselves. "School terms have increased fifty to one hundred and twenty five per cent; log houses are now extinct; box car houses are being replaced by substantial frame and brick ones; consolidated schools are becoming numerous and popular; every county has one or more high schools; agriculture, home economics, farm shop work, and manual training are found

in eighty per cent of them. Smith-Hughes work is being introduced in many places. Home economics has become the leader in vocational work in the schools. Agriculture ranks next in numbers, auto-work, machine shop, and industrial drawing are the leaders in the city schools, with commercial subjects close second."

NORMAL SCHOOL ACTIVE

The educational forces have been a big factor in the development of the country; and the East Tennessee State Normal has been a strong arm in the work.

The department of manual training has been organized to meet the needs of the particular section—the training of teachers for rural communities. The courses of study, projects, problems and methods have to keep teacher-training in mind at all times. The aesthetic problems peculiar to the city manual training work find little place. The outsider might be struck with the gross materialism of the work; but utility as a power, in this particular work, comes before beauty and the latter will gradually find its place and establish a proper equilibrium. Such problems as an orchard harrow, a wooden silo, a farm gate, fireless cooker, fire place baker, water system, mensuration blocks, laboratory apparatus, and shop equipment readily fit into the community life. A process worth learning may be taught on a project worth having.

"Ninety five per cent of the people of East Tennessee earn their living directly or indirectly by means of their hands. Their material prosperity, their comfort, their very happiness depends upon the skill with which their hands may serve them."

SPECIAL DIPLOMA OFFERED

The department offers work leading to a special diploma in manual training, and courses are elective to all students both men and women, except those enrolled in the primary course. The courses offered are elementary woodwork, mechanical drawing, advanced woodwork, farm mechanics, methods of manual training, and vocational drawing.

The use of native materials is encouraged by word and example. Some woods, thought to be worthless by local people, have been used to make very attractive and useful articles.

To assist the teachers and schools interested in manual training, a neat thirty-two page bulletin, Vol. VI, No. 8, has been issued; it gives a brief survey of work, a suggestive course of study, necessary equipment, and approximate costs.

—FOREST T. SELBY



*Academic, Art and Industrial Education
are combined in*
Printing

ENGLISH, spelling, punctuation, paragraphing, correct design, capitalization, harmonious color arrangements, color mixing, and technical processes always coordinate if Printing is used as an educational tool.

In North American schools and institutions, from coast to coast and from Canada to the Gulf of Mexico, instruction by means of Printing is making education a happy and interesting attainment.

Costs of installation, outfit and supplies are usually much lower than those of purely industrial subjects which do not coordinate with academic and art phases.

Teach with Printing

Write for literature, course of study and prices

F. K. PHILLIPS, *Manager*, EDUCATION DEPARTMENT

AMERICAN TYPE FOUNDERS COMPANY

300 COMMUNIPAW AVENUE

JERSEY CITY, NEW JERSEY





FIELD NOTES--(Continued)

MEETING OF VOCATIONAL EDUCATION
SOCIETY OF BOSTON

The Vocational Education Society of Boston enjoyed one of the most unique and interesting meetings in its history at Fort Banks, a United States Army Post at Winthrop, Mass., on Saturday, February 11, 1922, and in addition to the society members and their friends there were present a number of members of the Manual Arts Club,

"army of invasion" into the post mess hall for "chow." The casualties were few but the army cooks and K. P.'s will not soon forget the nature of the "assault" which was made on them. They rendered valiant service, however, and the army dinner was excellent in every particular, and one not soon to be forgotten by those privileged to enjoy it. The party then "retreated in order" and sought refuge in the post gymnasium, where Major-



A SECTION FROM SEVERAL FEET OF FILM SHOWING MEMBERS OF THE
VOCATIONAL EDUCATION SOCIETY OF BOSTON.

which represents the women teachers of manual training in Boston. Major-General Edwards, affectionately known in New England as "The Daddy of the 26th Division," was the guest of honor.

After arriving at the fort the party was divided into groups of eleven persons each and a guide was provided from the fort for each group who escorted the party to a number of points in the camp. Following this Captain Wallace Hackett directed the party on an inspection trip which embraced the ordnance magazine, defense guns, post schools, etc. Formal guard mount was next observed by the visitors and the usual military salute was fired in honor of the arrival of Major-General Edwards who, with President Hatch of the Society, led the

General Edwards personally met and spoke to each visitor and later made an informal speech which was characteristic of him whom New England's soldiers of the Great War have learned to love and respect so fully. Major French spoke at length of the various activities of the post, with particular reference to the army vocational schools, and President Hatch lent additional pleasure to the occasion by his timely remarks and witticisms.

Then came the showing of some very intimate pictures of army experiences which were taken by some of the men in Major-General Edwards' command, and many of these pictures have never been shown before. After the pictures the hall was cleared and dancing was enjoyed to the ac-

The
Lightning Line
TRADE MARK REG.
LL

An Exceptional Tool for Exceptional Schools

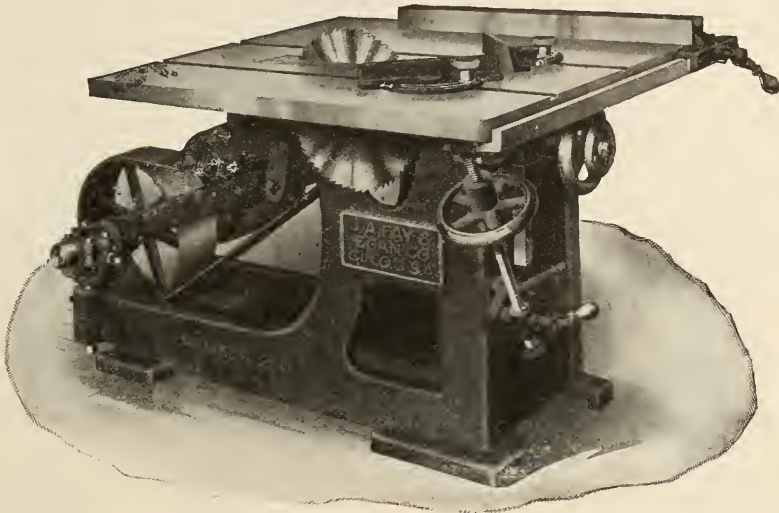

No. 260 "Lightning" Variety Saw

Manual Training instructors find this machine to be exactly as its name implies, as it is capable of doing a great variety of work. Machine is very heavy and possesses many advantages of quick and extremely accurate adjustments, that make it highly valuable in many lines of work.

With a 16" blade it will cut through stock $4\frac{1}{2}$ " thick. It will cut off 15" wide and take 24" between ripping fence and blade. Boring Table 19" long and 9" wide, has vertical adjustment of 9", and horizontal movement of 7".

Write today for Bulletin R-11

J. A. FAY & EGAN COMPANY

ESTABLISHED 1830

World's Oldest and Largest Manufacturers
of Woodworking Machinery

730-750 W. Front St.

CINCINNATI, OHIO



FIELD NOTES—(Continued)

companiment of music furnished by the post musicians, and as a fitting reminder of the unique and enjoyable occasion the entire party was photographed, with "Pop" Edwards and the post mascot in the center, after which those present voted this to be "the end of a perfect day."

—FRANCIS L. BAIN.

RADIOPHONE CONSTRUCTION
IN CHICAGO SCHOOLS

A scheme launched in the Chicago public schools may prove to be the forerunner of revolutionary teaching methods. Indeed, when this new program—which, by the way, is one of radiophone construction and installation—is completely developed, it may make it possible to attend school at home; for a number of schools are already equipped with radiophones and students in the manual arts department are learning how to make receiving sets which they may eventually install in their own rooms. In this way a student could stay in his residence and get most of the value of a recitation and have none of the inconveniences which may come from active participation.

While this speculation may be somewhat visionary, radiophones are very much of a reality in the Chicago schools. Definite plans have been developed and construction has begun on fifty of these radio sets at the Lane Technical High Schools according to a statement made by A. G. Bauersfeld, supervisor of technical work in the Chicago high schools. There is now a set which was made in one of the schools, in operation in Mr. Bauersfeld's office. Two classes of 24 pupils each are engaged in the work at this school. The construction of these sets is introduced as a definitely organized project in industrial education and not as a play activity. The students will make their own plans and blueprints, and otherwise follow a definite line of procedure. A co-operative arrangement has been made by William J. Clark, the radio editor of the Chicago American. This paper is assisting the scheme by giving publicity and by using the prints to educate its readers in radio activity and in encouraging them to make their own sets. The work in the schools is also supported by the Westinghouse Electrical Manufacturing Company. This company offers service by radiophone in the way of entertainments and instruction of various kinds.

FROM DELAWARE AND NEW JERSEY

INDUSTRIAL ARTS IN DOVER, DELAWARE

The industrial arts department of the Dover High School under the direction of Gerald E.

Yeaton is carrying on a wide variety of activities. Mr. Yeaton has not only had experience in high school work but also in the industrial field as apprentice supervisor and teacher of tradework.

The high school course in manual training covers a span of two years, providing that the student cares to go into the study this far, and includes the following: First year fundamentals of mechanical drawing, furniture design and construction, and any maintenance work that may arise.

Last term the boys completed a grand stand in the gymnasium, bicycle racks, typing and book-keeping tables and several other jobs. This year they are preparing to put an entire maple floor in the gymnasium, as well as to construct several flat top desks for the faculty. The second year boys are getting more drawing along trade lines, and practically all the finer points of the carpentry trade.

The mechanical and architectural drawing courses, also in charge of Mr. Yeaton, extend over two terms. The first three months of the term is occupied with correlative work, after which students are allowed to proceed according to their individual ability. Ninety minutes (two periods each day) is devoted to this subject.

The grammar grade manual training course, taking in but the sixth, seventh and eighth grades, owing to lack of room and equipment, is all correlative work until the boys reach the eighth grade, at which time they are allowed to advance on their initiative.

Dover contemplates erecting a five hundred thousand dollar school building sometime in the near future, and at which time it is hoped to be possible to teach more vocational work.

The Dover night sessions are now in full swing, several courses being offered to a most eager public. These courses are mechanical and architectural drawing, shop mathematics and shop work. Record breaking enrollment is also reported in the commercial and home economic evening classes.

MEETING OF THE
ESSEX COUNTY ARTS ASSOCIATION

A meeting of the Essex County Arts Association was held February 16, 1922 at the Burnet Street School, Newark, New Jersey.

Robert A. Campbell, Supervisor of Industrial Education for the State of New Jersey addressed the Industrial Arts section on "Tendencies and Aims in Manual Arts."

The Vocational section listened to Henry Louis Buller, Manager of the Jersey City Typographical Library and Museum on, "The Art of Printing"

"ECONOMY" 12-inch Swing

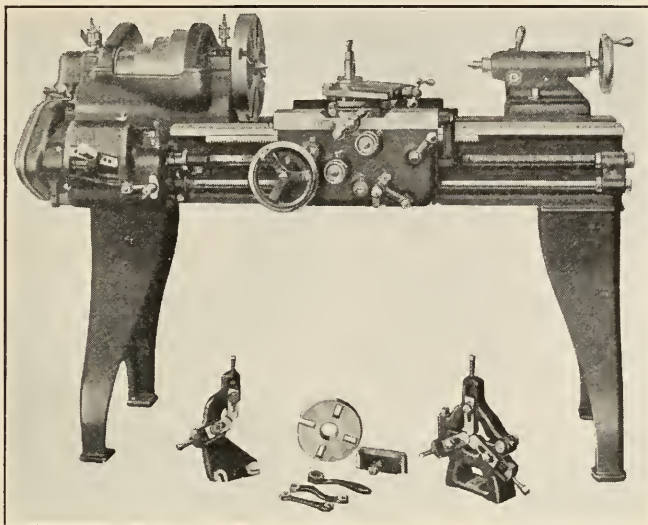

Single Back Geared Quick Change Engine Lathe

THIS lathe is designed especially to meet modern demands in commercial and school shops for a small heavy duty machine. It is high grade and extremely accurate. Before you select or specify for your shop

BE SURE to consider this lathe. Study the specifications and note the many special features of **bed, headstock, tailstock, carriage, apron and gear box.**

*Write today for
Descriptive Circular*

ROCKFORD LATHE & DRILL COMPANY, Rockford, Illinois

Kewaunee

MANUAL TRAINING FURNITURE

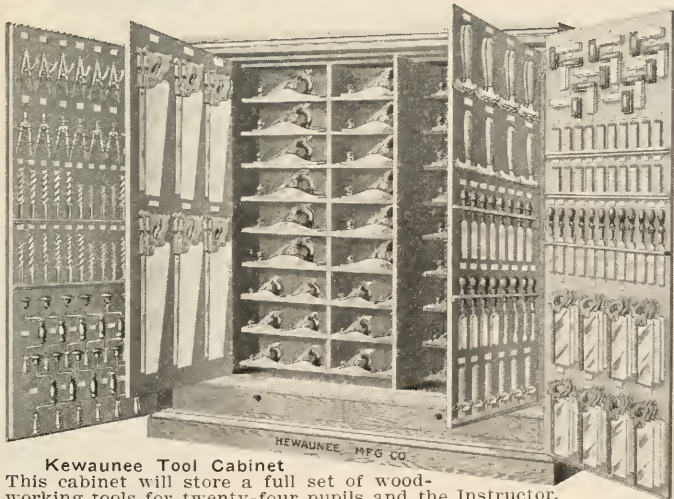

Kewaunee Tool Cabinet
This cabinet will store a full set of wood-working tools for twenty-four pupils and the Instructor. Each space and hook is numbered, and all tools are readily accessible.

In design, material and craftsmanship, Kewaunee Manual Training Furniture conforms to the very high standard of quality exemplified by all other Kewaunee Furniture.

W. A. Brandenburg, President of the State Manual Training Normal School, Pittsburg, Kan., wrote:

"I take pleasure in stating that the Kewaunee school furniture has been used in city schools and in the State Normal College where I have had charge of work for the past fifteen years. I have a high opinion of the quality and practical value of Kewaunee school furniture. I have used it in every department in educational work and have never been disappointed, except with probably one piece, and this disappointment was made good by the company."

Ask for a free copy of the Kewaunee Book. Address all inquiries to the factory at Kewaunee.

BRANCH OFFICES:

Chicago	Little Rock	Jackson, Miss.	Oklahoma City
Houston	Spokane	Columbus	San Francisco
Omaha	Baton Rouge	Denver	Phoenix
Minneapolis	Toronto, Can.	Kansas City	Greensboro, N. C.

Kewaunee Mfg. Co.
LABORATORY FURNITURE EXPERTS

New York Office, 70 Fifth Avenue
111 Lincoln St., Kewaunee, Wis.



FIELD NOTES—(Continued)

and to a discussion of the "Merits and Demerits of Productive Work" in the woodshop by Edgar E. Story of the Newark Boys' Vocational School. William S. Higbie of the Elizabeth Vocational School, Elizabeth, N. J. also addressed this section on the topic of, "Co-operation among Vocational Teachers."

Members of the Fine and Applied Arts Section enjoyed Miss Bonnie E. Snow in a talk on "Art in the Home" and John J. Cronin on "Art in Display."

The Program for the Household Arts Section included a talk by Miss Eleanor Oliver on "Home Making in School" and an open discussion on "How to develop an interest in Budgets in a class."

MANUAL TRAINING DEPARTMENT IN
NEWARK NORMAL SCHOOL

The New Jersey State Board of Education adopted a resolution February 4, 1922 to establish a two year special course in the State Normal School at Newark for training teachers for manual training for elementary and junior high schools.

This course will fill a long felt need and should be of great aid to manual training in New Jersey. Such a course has been urged by school men for some time and an immediate demand for graduates of this course is assured.

This new department will be under the direction of John J. Hatch, formerly supervisor of manual training in the Newark Public Schools and widely known as a man not only of splendid experience and training but as one who has a vision of the future of manual training and the ability to inspire. Several additional teachers will be added to the teaching staff at the Normal School to assist Mr. Hatch in making this department a success.

Salaries in New Jersey are exceptional with the demand for trained teachers far exceeding the available supply. This action of the New Jersey State Board will open up new opportunities for young men desirous of entering the teaching profession and should cause much satisfaction on the part of those interested in and concerned with the future of manual training.

TWENTIETH ANNIVERSARY OF THE
NEW YORK SCHOOL CRAFTS CLUB

A 20th Anniversary Dinner of the School Crafts Club was held at the Stratford House, New York City, February 18, 1922. Past presidents of the Club were guests of honor and responded to toasts. The following ex-presidents were present: Dr. James P. Haney, Austin W. Garritt, Dr. Ernest

B. Kent, Arthur W. Richards, Morris Greenberg, Chas. W. Ledley, Hugo B. Froehlich, John J. Hatch, and Richard Beyer. Communications were read from Wm. F. Vroom, New Brunswick, Canada, Meritt W. Haynes, Illinois, and William Noyes who universally expressed regret that distance made their attendance impossible.

Martin Corcoran, president of the club, presided as toast master.

—ALLEN D. BACKUS

AROUND NEW YORK

PROPOSED CHANGE IN COMPULSORY EDUCATION LAW

Legislation amending the compulsory education law so that after September 1, 1926, no child would receive an employment certificate, who was not a graduate of a public or parochial school and between fourteen and sixteen years of age, was advocated by Miss Jennie U. Minor, assistant secretary of the New York child labor committee, at a meeting of the New York City Principals' Association. Miss Minor said that the public schools were now holding 27,000 children between the age of fifteen and sixteen in school until they were sixteen. She suggested that a special course be provided for those children instead of compelling them to repeat their academic work until they reached the age when they could get their working papers.

To make those children mark time in the grades is a stultifying process. A majority of these children are motor-minded, and should be provided with instruction suitable to their needs.

Miss Minor told the principals that this proposal to amend the compulsory education law was opposed by the school officials of the city because of the physical inability to house the children.

George H. Chatfield, assistant director of attendance, opposed promoting Miss Minor's plan at this time. He referred to the present financial stress and declared that he would not think of increasing the burden of the cost of education until it was possible to see a way out of the present situation, which in his opinion would not be within three years.

Miss Minor's plan, he said, not only would be expensive, as it meant decreasing the size of classes, but the proposal would be followed by another calling for the repeal of the continuation school law. The work of these schools had not yet reached the stage where work could be properly evaluated. Mr. Chatfield felt that if the continuation schools were developed in the proper way, instead of being housed in the oldest and worst



COMPLETE WITH
ALL MODERN
FEATURES AND
EQUIPMENTS
GEARED HEAD

SIDNEY ENGINE LATHES

Meet Every School Shop Requirement

Write for Interesting Descriptive Matter

THE SIDNEY MACHINE TOOL CO.

SIDNEY, OHIO

**Already Adopted
In 70 Auto Classes**

Wright's "AUTOMOTIVE REPAIR"

Volume I—An Instruction Manual of Repair Jobs
for the General Repairman and Owner

By J. C. WRIGHT

Now being used in 70 institutions where automobile courses are given. It is an ideal text for classroom and shop use, covering actual practice, instruction and theory, under one cover.

530 pages. 6 by 9. Profusely illustrated.
Cloth, **\$3.50.**

Send NOW for copies on FREE EXAMINATION.

READY MAY 1st

Volume II
of this book—

REPAIR JOBS FOR

Electrical
Service Men.

56 actual electrical
repair jobs are given

FREE EXAMINATION COUPON

John Wiley & Sons, Inc.,
432 Fourth Avenue, New York City.
You may send me the following on 10 days' approval:

WRIGHT'S AUTOMOTIVE REPAIR

I agree to pay for the book or return it within 10 days of receipt.

Name

Address

If teacher, state school.....

If not teacher, give reference.....

M.T.M. 4-22



FIELD NOTES—(Continued)

buildings in the city, they would prove a valuable adjunct to the school system.

Mr. Chatfield contended that if attendance at school to the age of sixteen was to be made mandatory, state scholarships should be provided for those who would ordinarily have to go to business.

Mr. Chatfield said he had attended the meeting for the purpose of getting the sentiment of the principals of the workings of the present employment certificates law. Miss Olive M. Jones commended the law except so far as it keeps those who cannot qualify, physically, for working papers from going to business. It would be better to permit boys and girls to go to business and earn the money with which to pay for having physical defects remedied instead of being kept in school until the defects are corrected.

Miss Minor replied that these defects should have been corrected during the school life of the child. The reason this was not done, she said, was because the health officer was not empowered to enforce his recommendations. If he could do so, she thought the condition complained of could be avoided.

M. Chatfield differed with Miss Minor and agreed with Miss Jones. He pointed out that the inspection of school children did not take place while they are thirteen or fourteen years of age, but earlier, the object being to save the young child. While this is proper, he said, the work should be extended. The health record of every child, he believed, should be on file in school, and that when a child wanted to obtain working papers this record would be sufficient to enable him to get them.

ART SCHOLARSHIPS GRANTED

Twenty-four industrial art scholarships were awarded to the City High School students by the School Art League during the past year, according to a report recently made on the activities of the organization. Each of these scholarships enabled a talented boy or girl to secure one year's training in a professional art school. Art schools co-operating are the Pratt Institute and the New York School of Fine and Applied Art.

The students who have received scholarships from the School Art League have formed an Alumni. They have raised funds to pay the tuition of several high school graduates each term in recognition of the benefits that they have received thru the League.

Forty-three lectures and meetings were held at the Metropolitan Museum and the Brooklyn Museum, with a total attendance of 19,798.

A bequest of \$2,000 was received from Mrs. Helen Foster Barnett to endow the St. Gauden's medal.

INDUSTRIAL ARTS SCHOLARSHIPS

Fourteen of the most artistically gifted pupils of the high schools have just been awarded industrial arts scholarship by the School Art League. The recipients represent eleven high schools. The winners of the scholarships are to enter upon their advanced work in the New York School of Fine and Applied Art. Each scholarship pays the fees of the student for a year of post-graduate study in costume illustration, commercial designing, textile designing, or interior decoration.

An additional scholarship has also been awarded in the Pratt Institute to a student in the Commercial High School for boys.

SHOP TEACHERS' STUDY GROUPS

A year ago the Associated Teachers of Shop-work of the public schools organized a number of study groups. Among these was a class in construction of model sailing yachts under the leadership of Thomas Darling, teacher of shopwork, and also a student of yacht design. There were twenty men in this class and each completed a model, ten of which were exhibited at the "Motor Boat Show" in Grand Central Palace.

During the present year the second class was organized under the same leader, and thirty-six teachers took up the course. A number of the boats made by this class were also on exhibition. The two classes worked on different models, both of which were especially designed for the purpose by Mr. Darling.

The ultimate object of the study groups is to train the instructors so that they can teach the boys how to make smaller yachts of similar designs. In many of the schools the boys are already at work during their shop period on models of boats. Next year the boys will be organized into boat clubs and compete in races for prizes. It is the plan to interest the boys in this sport, and in boats and shipping generally.

It is planned to establish evening classes for males from sixteen to fifty years of age, in model yacht construction, art metal work, wireless telegraphy, stage setting, wood-carving, and furniture making. The first class to be organized will be the one in model yacht construction under Mr. Darling.

—W. H. DOOLEY.



THE STOUT INSTITUTE

Nine Weeks Summer Session

June 26–August 25, 1922

Regular Session Thirty-Six Weeks

September 11, 1922–June 1, 1923

The summer session gives opportunity for students to secure a full semester's credit in shop or laboratory courses by lengthening the periods for this work during the summer session. A half semester's credit can be secured in five hour academic courses.

Summer Session credits apply on work required for the diploma or degree given by The Stout Institute.

The following groups of courses are offered:

Vocational Education—7 professional courses, 27 shop courses.

Industrial Arts—33 courses.

Household Arts—24 courses.

Science and academic work required for diploma or degree—26 courses.

Athletic Coaching—5 courses.

Catalog giving outlines of courses, schedule of classes for summer session, and full information as to qualifications for entrance, requirements for graduation, and expenses for summer session or academic year, now in press and will be sent to anyone on application to

L. D. HARVEY, President

THE STOUT INSTITUTE

Menomonie, Wis.

The University of Minnesota

SUMMER SESSION 1922

First Term: June 19 to July 29

Second Term: July 31 to Sept. 2

Registration Days June 17 and June 19

COURSES IN

Trade and Industrial Education
Teacher Training
Manual Training

The University of Minnesota will offer a wide variety of courses in the Theory and Practice of Trade and Industrial Education and Manual Training, to both men and women, during its Summer Session.

In cooperation with Dunwoody Institute and the College of Engineering there will be offered approximately fifty shop and trade courses.

Because of its desirable location the University of Minnesota offers a rare opportunity to combine advanced study with a summer of unusual recreational advantages.

For further information or copy of the Summer Session bulletin write to the

Director of the Summer Session
or the Registrar

University of Minnesota

MINNEAPOLIS, MINNESOTA

Bradley Institute

Summer Session 1922

First Term June 19 to July 21

Second Term July 24 to Aug. 26

Offers opportunity for study to teachers, supervisors and administrators of the Manual Arts, Industrial Education and Home Economics.

Courses in a wide variety of subjects will be available. Summer credits may be applied toward certificate, A. B. or B. S. Degree.

Send for preliminary announcement and detailed information.

Director Summer Session

Bradley Polytechnic Institute

Peoria, Illinois

Carnegie Institute of Technology

Summer Session

Courses for Teachers of Manual and Industrial Arts

July 5 to Aug. 12, 1922

Exceptional Shop Facilities

Courses in Manual Arts Education, Woodworking, Cabinetmaking, Sheet Metal Work, Drafting.

Other shops open to teachers—Machine, Patternmaking, Forge, Electric Equipment, Plumbing, Automobile.

Instruction given by regular members of the faculty.

Wide range of subjects offered by other departments.

For catalogue and further information,
address the

REGISTRAR, Box M, CARNEGIE INSTITUTE OF TECHNOLOGY

Schenley Park, Pittsburgh, Pa.

University of Wisconsin

Department of Industrial Education
and Applied Arts

Summer Session, June 26-Aug. 4

Classes in Manual and Industrial Arts; Drawing and Painting, Commercial Art, Design, Art-crafts Work, Elementary Hand-work; Vocational and Industrial Education. Special attention to teaching methods. Courses leading to B. S. in Industrial Education or in Applied Arts. Graduate courses.

Write for Summer Bulletin

DIRECTOR, UNIVERSITY
MADISON, WISCONSIN

School Shop Installation and Maintenance

By L. S. GREENE

Professor of Industrial Education, University of Florida

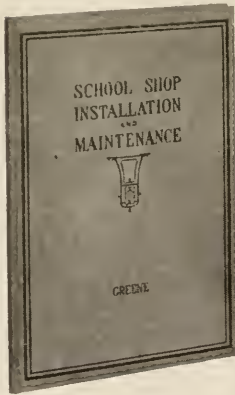

For
Every
Teacher
of
Shop
Work

THIS new book gives selected facts about shop equipment—how to install and maintain properly. It brings together selected facts known to engineers, expert mechanics, and experienced teachers, and presents them so as to be of the greatest help in equipping and caring for school shops. It is, in fact, a hand book of information, rules and methods needed in solving the problems of equipment and maintenance. It gives many facts hard to secure and many more which heretofore could be obtained only thru experience. It shows clearly how to avoid costly mistakes and sooner or later will be worth to the shop teacher many times its cost. *Postpaid, \$1.25.*

The Manual Arts Press
PEORIA, ILLINOIS

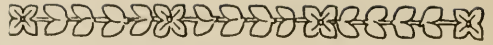

FIELD NOTES—(Continued)

CIVIL SERVICE COMMISSION CALLS FOR TEACHERS

AN OPEN, competitive examination has been announced by the United States Civil Service Commission for the following positions: rehabilitation assistant; teacher of high school subjects; teacher of commercial subjects; teacher of technical subjects; teacher of agriculture; and teachers of trade and industrial subjects. The duties of persons appointed thru these examinations will be to teach disabled soldiers and marines. The examinations may be taken by mail by applying to the Civil Service Commission. Salaries offered in this connection are from \$1,600 to \$2,400. The opportunity to apply for examinations is extended for an indefinite period.

WESTERN ARTS ASSOCIATION CONVENTION

MAY 2, 3, 4, 5, 1922

The Western Arts Association, an organization composed of directors, teachers and others interested in Art, Drawing, Handicraft, Household Arts, Domestic Science, Industrial Arts, and Manual Training will hold its next annual convention in Cincinnati, Ohio on May 2, 3, 4 and 5, 1922.

There will be many exhibits of drawings, paintings, handicraft, arts and crafts, ceramics, gowns, embroidery, woodwork; forging, sheet metal work, printing and all types of work designed and executed by pupils of these subjects in the schools throughout the middle west.

The exhibits will be on display during the convention at the Ohio Mechanics Institute Building, located at Walnut and Canal Streets. This school is one of the finest of its type in the United States.

The building is a modern structure five stories high occupying almost an entire city block.

The convention sessions will be held in the beautiful Emery Auditorium, the home of the Cincinnati Symphony Orchestra. This beautiful auditorium is a part of the Ohio Mechanics Institute Building and has a seating capacity of over two thousand.

Many speakers of national prominence on the subjects of art, domestic science, household arts, industrial arts and manual training will address the convention on topics of current interest to teachers of these subjects. In addition to the general meetings to be held in Emery Auditorium, there will be numerous sectional meetings held, where special subjects will be presented and discussed and round table matters presented for general discussion of those present.

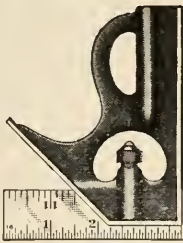

NEW LUFKIN

**"UNIVERSAL"
TRY AND MITRE
SQUARES**

FOR WOODWORKERS

**HIGH GRADE YET POPULAR PRICED
ACCURATE—DURABLE—WELL DESIGNED**

No. 65L—WITH LEVEL

No. 65—WITHOUT LEVEL



**Made in 9-inch and
12-inch lengths**

**Distinct marking; movable yet secure head. Serves also as marking, height and depth gauge,
level and plumb, and separate rule. If Unobtainable at Dealers Write Us Direct.**

Send for Catalogue

THE LUFKIN RULE CO.

**SAGINAW, MICH.
New York**

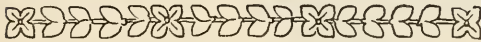

FIELD NOTES—(Continued)

Cincinnati with its surrounding hills is a wonderfully beautiful and picturesque city. It has enviable reputation as a leading art and musical center.

Cincinnati boasts of many wonderful private art collections, a public school system that ranks with the first in the United States, a wonderful park system, an Art Academy and Art Museum that are internationally famous. It is also the home of such noted industrial plants as the Rookwood Pottery, Gruen Watchcase Company, American Book Company and numerous others that are known the world over. All of these attractions and many more will be opened for inspection by the delegates and visitors registering at the convention.

No teacher of any of the subjects previously mentioned can afford to miss this convention. It will not only be profitable from the standpoint of the many new ideas to be gleaned, the acquaintances to be made and the inspiration received, but will assist in work of the specialist to do bigger things in his chosen field of work. The memory of having seen, heard, and observed the work that others are doing in this vast educational field will repay you hundredfold.

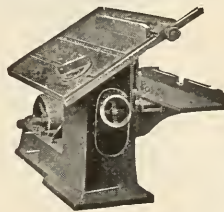

Crescent Wood Working Machines

are the tools your students will eventually use so give them the opportunity now of learning about this splendid line of wood working machinery.

Send today for our catalog of band saws, jointers, saw table, shapers, variety wood workers, planers, planers and matchers, cut off saws, disk grinders, borers, hollow chisel mortisers, Universal wood workers.

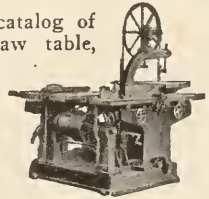

The Crescent Machine Co.

46 CHERRY ST.

LEETONIA, OHIO

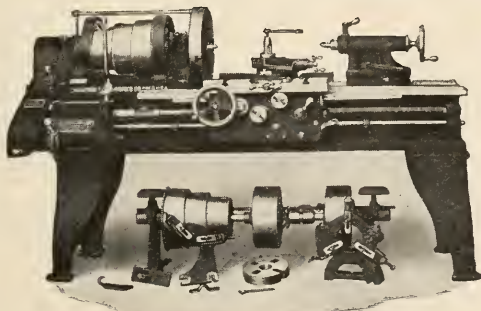

Champion Lathes

A quality engine lathe, accurate, convenient to operate and at a very attractive price to manual training and vocational schools.

Made in four sizes: 13", 15", 17" and 19"

Champion Tool Works

Winton Place

Cincinnati, Ohio

MONARCH
JUNIOR
MOTOR
DRIVE
LATHE

T H E
BIGGEST
LITTLE
LATHE
BUILT

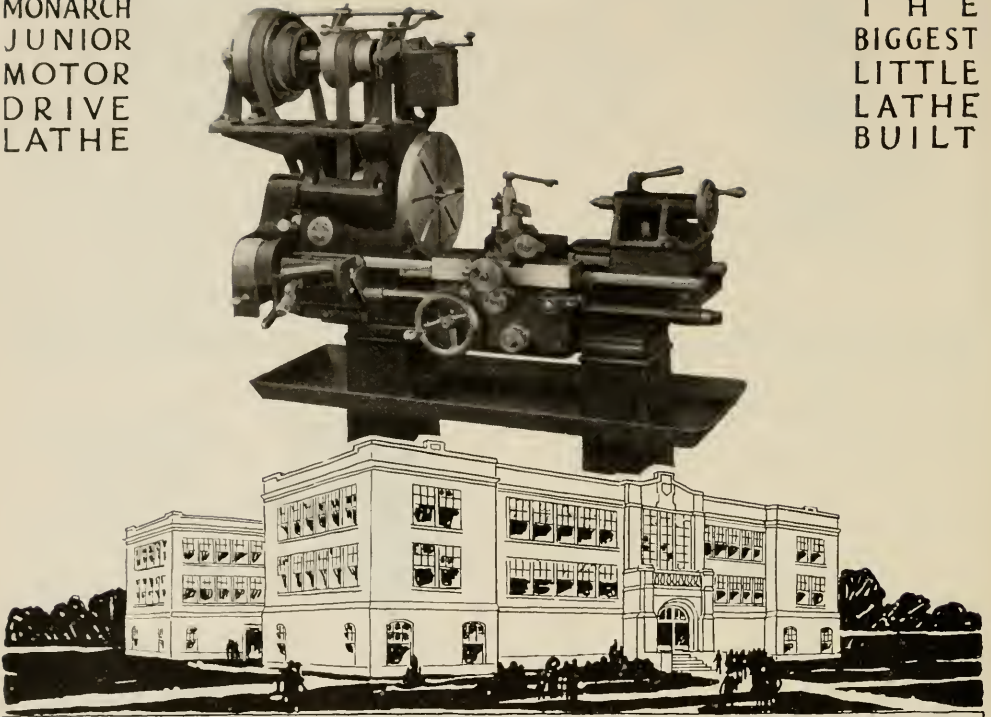

Every Vocational School Should Be Equipped with a Monarch Junior Lathe

The importance of metal working as a part of every young man's educational training cannot be over-emphasized. The trained and skilled specialists in industry of the coming generation will be the product of our vocational training school of today.

In the installation of a metal working department in any school, the first and the most important equipment to be considered is the MONARCH LATHE.

Particularly designed to meet the requirements of Vocational school training after careful study of the conditions and needs that must be met.

THE MONARCH TECHNICAL SERVICE IS FREE

We have a nation wide engineering service who will help you plan a complete metal working department and furnish installation plans for complete equipment together with estimate. We gladly extend this service to you upon request and without charge.

THE MONARCH MACHINE TOOL CO.

203 Oak Street
SIDNEY, O.

Manual Training Magazine

APRIL, 1922

THE PRESENT STATUS OF INDUSTRIAL ARTS EDUCATION IN OUR ELEMENTARY SCHOOLS¹

I. EMPHASIS IN PURPOSE AND CONTENT

A. H. EDGERTON, Assistant Professor, Indiana University

OUR most progressive public school systems now recognize the important need for properly representing, organizing, and offering industrial arts activities in the first six grades of school experience. This notable tendency of the past few years undoubtedly is due in part to the marked change in the purpose, content, and method of the industrial work now given as a means of developing general intelligence and knowledge of the industries during the elementary-school period in much of the best public school curricula. At least, this is the verdict of a large majority (117) of the 141 progressive school systems which have reported recently from 19 different states on the industrial activities now being experienced by their elementary school pupils.

While the emphasis in the work and study in these elementary grades (one to six, inclusive) differs somewhat in keeping with the various types of schools investigated, Table I and Fig. 1 make it evident that *those courses which are designed for studying present-day industries in an elementary way, in order that boys and girls may be more intelligent and appreciative of the conditions, materials, processes, and methods involved in manufacturing the products observed in everyday life, are rapidly replacing the so-called "busy work" or handwork courses,*

many of which have had the doing and making of things as their primary aim or purpose.

This investigation and a number of recent school surveys make it evident that the larger values in elementary industrial arts cannot be realized alone by merely making even useful and serviceable products. If these activities are to continue to occupy an important place in the elementary school program, it is believed by many that they will be expected to share the responsibility with other subjects for *helping pupils to develop appreciative insight and reasoning ability in terms of significant interests and actual life needs.* Both psychology and experience have taught us that children from six to twelve years of age are mainly concerned with the activities and situations in which adults are engaged, rather than in series of exercises, models, or pieces of an abstract nature. Then, too, it is a generally accepted fact today that extended repetition of the same operations and processes causes children of this age to lose interest in their work and also to gain a larger amount of technic in the use of hand tools than is commensurate with the relative value of the time and energy expended. Altho the importance of skill or dexterity is fully recognized as a factor in general elementary education, results of several experiments and observations, which will be given later in these articles, clearly indicate that either one of these will prove of most value when vitalized

¹ This is the first of a series of three articles which are the result of a study of 141 selected school systems.

thru those concrete experiences that stimulate thinking and actually relate to the needs of everyday life.

CHIEF CLAIMS REPORTED FOR OFFERING ELEMENTARY INDUSTRIAL ARTS

In the reports from these 141 school systems, each of which gave its main reason for offering industrial work in the elementary school, the four leading claims, when collated, were found to be given the order of importance shown in Table I below:

ITEM	NUMBER
TABLE I. Listing the Chief Reason for Offering Industrial Arts Instruction in the First Six Grades of Each of 141 Public School Systems.	
1. Giving a basis for judgment in the selection and use of industrial products and service.....	51
2. Developing an appreciation for the economic and social phases of industry.....	39
3. Gaining sufficient experience in industrial processes to meet the pupil's needs and to illustrate the industry.....	32
4. Vitalizing geography, history, arithmetic, oral and written expression, and other subjects in the curriculum.....	19
Total Number Reported.....	141

Altho it was discovered that in a few cases these claims were expressions of future plans rather than the present status and conduct of the work, nevertheless, only about six per cent of these public school systems have made practically no changes in the methods of organizing and conducting their elementary industrial work during the past nine years. On the other hand, *over eighty per cent of these school systems show every evidence of having undergone desirable reorganization in methods and procedure.*

CHANGING TENDENCIES IN METHODS FOR ORGANIZING AND CONDUCTING ACTIVITIES

Industrial arts as an elementary school subject has been well defined as "the distilled experience of man in his resolution of natural materials to his needs for creature comfort, to the end that he may more richly live his spiritual life."² This

resolution of natural materials to man's needs involves the study of our great industrial life. With advancing civilization a highly specialized industrial system has been developed. The finished products by which the needs of man are supplied are the results of complicated manufacturing processes. By means of these processes the raw materials of industry are transformed into the many finished products of varying quality and value required by man. The school work is

necessarily so graded that the simple phases of industrial experience and study may be developed in the lower grades (one, two and three) and the more complex phases taken up in the higher grades (four, five, and six).

The composite of the individual reports in this investigation, as tabulated in Table I, shows that the purpose of the elementary industrial arts in an increasing number of these schools is to provide a background of experience and knowledge, using various types of materials that will enable the pupils to appreciate and understand those industrial processes that supply fundamental needs. The subject-matter is, therefore, in the main, found in a consideration of how man's food, clothing, shelter, utensils, tools, machines, and other utilities are provided. Fig. I gives the total number and per cent of the 141 school systems offering instruction in each type of industrial experience reported. The materials of study

² See Bulletin on "Fundamental Values in Industrial Education," Teachers College, Columbia University, Publication.

ordinarily used are clay, wood, metal, food, textiles, paper, and the like. Aside from the kind of work already indicated, opportunity also is usually given for constructive work from the standpoint of

work should occur whenever it aids most in an understanding of the industry or in making the subject more interesting.

It is generally agreed that the actual "try out" courses for specialized inter-

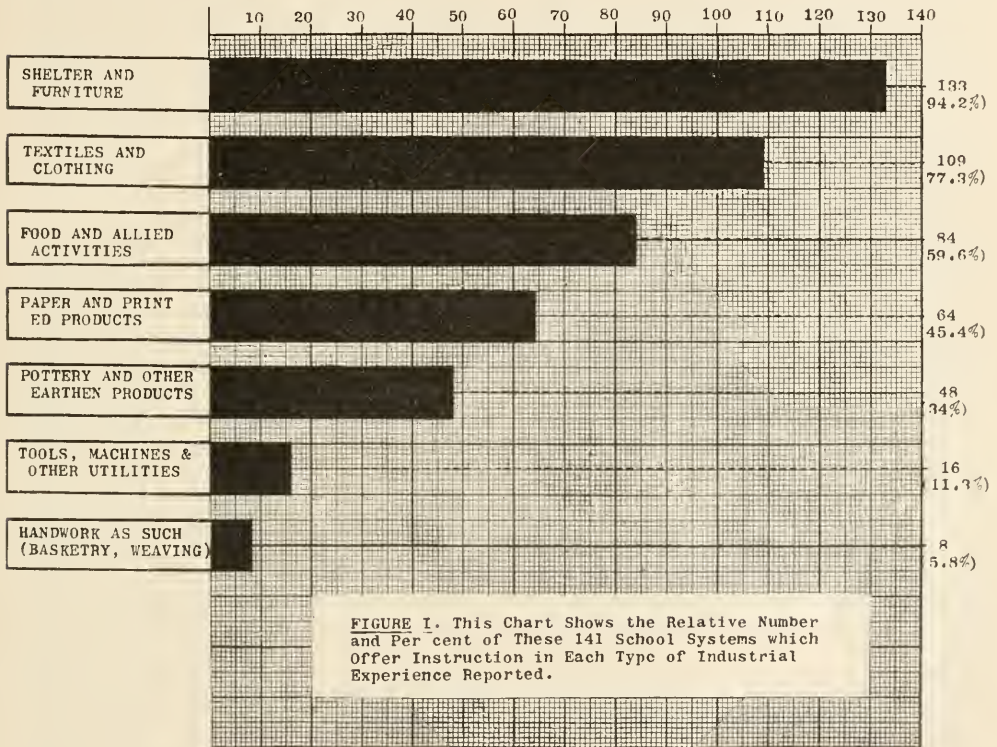

free expression at such stated times as Hallowe'en, Christmas, Easter, and as other occasions dictate.

Manipulative work frequently is given major emphasis as far as the pupils are concerned, for it is believed by a majority (92.7 per cent) of the teachers concerned that the knowledge and appreciation most vital to their boys and girls are secured in this way. Nevertheless, undue stress need not be placed upon this phase of the work if *the problems and projects challenge mental as well as manual activity*. The experience to date indicates that a maximum of time preferably is given to elementary studies of the various industries, and that manipulative

ests and aptitudes, as such, may well be taken up intensively in grades above the sixth.³ Several of these teachers state they believe it is desirable, however, by the time the child reaches the seventh grade (1) that he should have a fairly clear but general understanding of the production in the important industries which are being carried on about him; (2) that he should know something of the persons that are engaged in these industrial pursuits; and (3) that he should be somewhat acquainted with the pos-

³ Edgerton, A. H. "Industrial Arts and Prevocational Education in Our Intermediate and Junior High Schools," *Industrial Arts Magazine*, October, 1921.

sibilities that are open to him in such occupations. Questions concerning sources and preparation of materials, manufacturing processes, and the character and lives of the workers arise in a natural way, and, where these are given proper attention, will contribute materially to an intelligent understanding of present-day industry. Excursions, moving pictures, exhibits, selected readings, and discussions likewise become important factors in the development of this phase of the study.

Leon L. Winslow, who is specialist in drawing and industrial training for the New York State Department of Education, has stated clearly the relation which might well exist between the elementary industrial arts, the so-called fine arts, and other school subjects, as follows:

For the purpose of organization, most of the drawing (art) and construction work done in schools falls to the subject of industrial arts, not because it is a manual subject but rather because it is an industrial subject and because industry deals more with drawing and construction than do history or geography or arithmetic. As phases of school life, drawing and construction are at the disposal of all school studies, but the time has gone by when drawing and manual training can be advantageously regarded as separate subjects in the elementary school course. Either one is but a part of the subject which it is intended to classify and intensify. We therefore, choose to form the new subject of industrial arts by combining drawing and construction with an educative subject-matter relating to industry.

When the industry is once chosen, the class is put to work investigating it, collecting information from all possible sources. Much of the material is obtained thru actual contact with those engaged in it or who handle its product. Some facts will be gleaned from reference books. The topics to be considered will depend upon the information available and the ability of the class. The following outline is helpful in considering what may constitute the subject-matter in each industry studied: (1) The value of the industry to man; how we are affected by it, (2) The evolution of the industry; its story, its heroes of invention (history), (3) Characteristics of the product; what constitutes excellence, (4) Materials employed, where they come from (geography), (5) Processes involved, (6) Tools used, (7) Healthfulness (hygiene), (8) Hours and

wages, (9) The training of the workers, (10) The part played in the industry by arithmetic, (11) The part played by drawing and design, (12) References to the industry found in literature, (13) The industry as depicted in art.

The subject-matter of industrial arts includes such of the principles of art as are involved continually in each industry as it is taken up. Masterpieces in painting and sculpture considered as records made by man at various times and under varying conditions, will be treated from the aesthetic side, primarily. Art instruction will be amply provided for, and yet art will not be considered, as it has sometimes been in the past, as an end in itself.

The handwork is based upon the subject-matter studied and its two kinds: (1) Drawing, including color, representation and design; (2) construction, including the preparation and combination of materials. All projects are considered as means of expressing ideas and feelings gotten from a study of the activities and not merely as pieces of handwork to go along with the various studies. Handwork should always result from a definite purpose calling for it.*

In a few of the schools investigated a special arrangement has been made for the pupils from about eight to twelve years of age whereby they spend part of their time serving as "helpers" or "assistants" to the older pupils. This plan, which obviously offers limited educational value, is intended to give the younger children opportunity to acquire experience thru observation and very elementary participation.

PROPER CORRELATION ENRICHES ELEMENTARY SCHOOL CURRICULUM

It is pointed out by a number of educators that illustrative handwork is not necessarily industrial arts, as the former is mainly a means of arousing interest in and developing geography, history, and other school subjects. That is, they insist that this form of activity rarely deals with the study of the processes involved in changing raw materials into more

*See Bulletin on "Industrial Arts in the Elementary Grades," State Department of Education publication, Albany, N. Y.

valuable products in the industries, and, consequently, it cannot correctly be classified as strictly industrial arts education.

Altho the name of the study, after all, is not of first importance, *there unquestionably is need in elementary education for work and study which involve an elementary interpretation of the many vital but complicated industrial situations, conditions, and relationships that confront all citizens and consumers both early and late in life.* In this connection, the industrial arts problems or projects which are thought out, planned, and developed by the younger boys and girls undoubtedly should be illustrative, at least, in so far as the illustrations help to develop the study of industries. At any rate, one striking feature observed more and more in the elementary industrial arts classes is the fact that this subject correlates easily and naturally with the rest of the school curricula. Much of this valuable work and study is being given during the history, geography, and reading periods. In fact, it is frequently the case that little special time is set aside for this industrial arts work in flexible school programs, because it is so closely interwoven with such subjects as those just mentioned. In order to realize the most value from these studies, however, it becomes necessary for each grade teacher to so acquaint herself with a knowledge of the important industries that she can seize the opportunity to effectively correlate the industrial arts with the other related school subjects.

Professor F. G. Bonser of Teachers College, Columbia University, has called our attention forcefully to this promising tendency in elementary education as follows:

Not only are values developed in relationship to the industries themselves, but the immediate real, tangible materials of these activities and interests centering in everyday use create the needs for and

the problems in most of the other school subjects. They make appreciable a reason for arithmetic and geography and history. Vitaly inherent in them lie the problems of hygiene and sanitation. Much of nature study and science have their very reason for existence as school studies in the industrial problems whose solution is dependent upon them. Indeed, the study of the industries viewed aright is the very foundation upon which any effective organization of elementary education must be based or it will be abstract and remote from life. By the study of clothing materials and processes from the raw textile fibers to finished fabrics and garments; pottery from the clay banks to finished china and other earthenwares; shelter from the forest to completed dwelling houses and their furnishings; or from quarry and mine to completed stone, concrete and steel edifices, large and small; books from the paper mill to the publisher's salesroom; and all of the various important fields of industrial production from raw materials to finished products, from simple, primitive methods to the complex manufacture of the twentieth century, —by such study we have the approach to almost every phase of present-day life with means for interpreting it in terms of economic, esthetic, civic and social values.⁴

The proper teaching of the industrial arts, as already outlined, will not only enrich each closely related subject, but these subjects in turn will vitalize the study of industrial arts.

SUGGESTIVE TYPES OF THESE ELEMENTARY INDUSTRIAL ARTS ACTIVITIES

The following elementary industrial arts units were developed successfully in grades from one to six, inclusive, under the supervision of Miss Rosana Hunter, who formerly was an instructor of industrial arts at Indiana University and at present is affiliated with the Indianapolis, Indiana, Public Schools.

CLOTHING AND TEXTILES (First Grade)

In the first grade the study of textiles was necessarily of a very simple type. The main object was to convey to the children the idea that many of

⁴ Bonser, Frederick G. "Industrial Education in Present School Problems," *School and Society*, August 26, 1916, Vol. IV.

the useful, enjoyable things in life mean work upon the part of hundreds of people, and that the preparation of clothing and like material involves a great industry. Observation of the clothing that each child wore was made—how it was made up of tiny threads woven over and under each other. This same thought was applied to draperies, linen, bed clothing, and other textiles used in the homes. After the children had conceived the idea of what weaving really meant, the question was suggested as to how each tiny separate thread was made. A simple study of single threads of ravelings followed. By untwisting and twisting again to make up a thread, the children were led to see that a thread was nothing more than a number of fibers twisted around each other. A story was then told of the great factories where just such twisting of fibers to make threads was performed. Pictures were brought in to help the children realize that such was the case. All of this finally led to the question as to where the first fibers were obtained, and stories of the sheep, flax and cotton were told. The children developed their own questions and problems, and consequently were most interested in solving and answering them.

After the twisting of threads was understood, the subject of weaving was again taken up. Pictures were used to show how this was done in large industrial plants. Manipulation became an important part of the work at this period. Some small looms were made with the help of the teacher by fastening four pieces of wood securely together in the form of a rectangle and notching the end pieces so that the warp threads could be strung around them. Upon these looms the children wove small rugs for a doll house that had been made by the older pupils. Several children worked upon the same rug, for the method of weaving and not the finished product was the real object in mind. The idea of textiles was further carried out in connection with this doll house by the making of curtains, draperies, and bed linen.

This work was correlated with the story and reading periods by using the stories of the life of the sheep on the ranch, of a cotton plant, of Pippa, of Arachne, and numerous others of this type. In connection with the nature study work, the oriole's nest was observed. The spider was cited as a weaver, and the suggestion that the caterpillar might be called a weaver led to a talk about the silk worm. A window box was obtained and flax seed planted. This was watched with much zest by the children, and when the plants matured they took great interest in seeing how the fiber could be taken from the plant and twisted into threads.

SHELTER—WOOD

(Second Grade)

A study of the wood industry was begun with a socialized recitation about woods or, as we eventually called them, forests. The story of the "Pine Tree" by Hans Andersen was told and the children were helped to realize what was really meant by a forest. Illustrative material in the form of pictures was abundantly used, the children bringing much of this from home.

Eventually the pine tree was singled out as a type and an elementary study was made of it and its characteristics. By story and illustration its life was carried along from the forest until it was cut down by the lumberman and brought to the lumber mill. Then the following steps were brought out, always in a manner that could be understood by the children: the cutting of the great planks from a log, the sawing and planing of the plank in the mill, the final making of the boards into houses, furniture, or other useful articles. The story of the carpenter was introduced here and carried out both in reading and in song. Illustrative material of lumber mills and saw mills was constantly used to impress upon the children the idea that the wood industry is an important part of the world's work.

The manipulative part of the work consisted of the making of a rather crude bird house from material that the children had brought in. The house was built for a wren, consequently it did not call for much material. The project was given the finishing touches by sandpapering and by staining. The latter was done long before it was used in order that the odor might disappear before the birds wished to build. The staining of the house led to a discussion of the grain of wood, and one or two methods of finishing woods as carried on in furniture factories.

PAPER MAKING

(Third Grade)

The manipulative phase of the study of the paper industry consisted of making a small booklet that was used to hold school papers, which the children wished to save. In connection with this booklet, strawboard, cover paper, and binder's cloth were brought under observation. This easily led to a study on the part of the children to find out how books and paper were originally made and how they are made today.

The origin of paper making was taken up thru the story of the keeping of records by the ancient people of Asia, Greece, and Rome. The wax and clay tablets were discussed and their non-durability pointed out. The story of Egyptian paper making from papyrus was developed and this led to the

story of the use of sheepskin, calfskin, flax and cotton fibers for the same purpose. Illustrative material of old pamphlets that had been illustrated and printed by hand was shown. The invention of the printing press and the great demand for paper led up to the present manufacturing of paper.

In connection with the industry of today, the following points were emphasized: the obtaining of rags and the sorting of these, the securing of old paper and the combining of rags and paper, the cutting, mixing, rolling, drying, coloring, and finishing of paper. The difference between blotting paper, writing paper, cardboard, and tissue paper was observed. The making of certain kinds of paper from wood fiber was correlated with the reading period. The children were keen enough to bring up the subject of the making of paper clothing during the last few years.

Some small boys undertook to try paper making at home by pulverizing rags and paper together and by boiling them in a little lye water with rosin to hold the fibers together. The result was a very heavy crude blotting paper that helped much in giving an idea as to how the work is done in the factory. Other children made up charts of samples of different kinds of paper that could be found. These charts were on exhibition in the schoolroom and were viewed with great pride by the makers. Helpful illustrative material for the study of this industry was obtained from the Hampshire Paper Company at South Hadley Falls, Mass., and the Forest Paper Company at Yarmouthville, Me.

FOOD

(Fourth Grade)

In the fourth grade, emphasis was laid upon the preparation of meats, and also of wheat as a cereal for our use. In connection with the former, the life of the rancher was taken up in the geography period. The beef was traced from the ranch to the stockyards and the packing house. Some time was given to the preparation of the meat after the beef was killed. Allen's Industrial Reader was used extensively with this work, and some very good material was obtained from Morris and Company in Chicago. (The latter contains excellent illustrations and carries the work along the different processes of refrigerating, drying, smoking, and canning). The place of this industry in the United States, the approximate number of people employed, and the location of the large stockyards and meat-packing establishments in this and other countries were studied. The story of the raising of sheep for food was taken up in much the same manner as that of the beef.

With the study of the cereal, the story of a grain of wheat was traced from the wheat fields of the northwest to the time when the loaf of bread, or the breakfast food, was placed upon the dining table. Consideration was given to the number of persons employed in this industry and its place in the world's work. Materials obtained from the Washburn-Crosby Company showing a diagram of the milling processes in the flour mill were found helpful. Stories of "How the World is Fed" were read and a comparison was made of the ancient ways of making flour and meal as compared with those of the present. The whole subject was further vitalized by a visit to a small flour mill nearby.

METALS—IRON AND STEEL

(Fifth Grade)

The fifth grade was studying the United States in geography. One of the important natural resources proved to be iron ore. One of the chief industries involved was the transforming of iron into steel. This gave us a splendid opportunity to investigate the iron industry. A study was made of the early discoveries of iron and its smelting by ancient people. The fact was brought out that in the history of civilization a certain epoch was known as the Iron Age, when people first began to substitute iron for wood and stone. The history of the smelting of iron was traced up to the present method of manufacturing. Special attention was given to the difference between the open hearth and the Bessemer furnace. The effect of the iron industry upon civilization in regards to machinery, transportation, building, and tools was noted. Outstanding individuals who had done much to promote the industry were mentioned. The children learned that Neilson, Siemens, and Bessemer had as important an influence upon our lives as did Washington, Franklin, and many other men to whose lives so much time is given in the schoolroom.

By the time this study was completed, the children knew the main facts concerning the history of the iron industry, the names of the men who had promoted the industry, the different kinds of work, and the approximate wage of each worker in the industry. Since the workers of the metal industry are unionized, this led to a slight discussion of the union and its purpose. The discussion of the union led to introductory observations of factory working conditions and workmen's compensation laws.

The manipulative phase of this study of the metal industry consisted of the making of a lead paper weight. This was done by first making the mould of clay. The lead was then melted over a Bunsen

flame and poured into the mould. After cooling, the mould was knocked off and the weight bore the imprint of any shape the mould may have been.

The idea of the work in the mills was made more vital by a set of stereopticon slides that was borrowed from the Illinois Steel Company of Chicago. These slides told the whole industrial story from the raw material to the finished product.

BRICK MAKING

(Sixth Grade)

The study of the clay industry in connection with the making of bricks was brought in thru the geography of Indiana. Since Brazil, Indiana, is a great brick-producing region, our interests were naturally aroused with this kind of work. The making of brick was traced from early Egyptian and Assyrian times up to the present day. Much time was given to the development of this industry in our own country, and this work led to a study of the location of the large brick-producing regions of Indiana and the United States. The study of the processes of the industry involved the production of the raw material, its preparation for use, its tempering, and its moulding. Under the subject of moulding, the soft mud, stiff mud, and dry processes were discussed. Quite a little time was given to the subject of firing, and a visit to a brick kiln was made by the class.

After the class felt that it understood, to some extent, the different kinds of work in connection with this industry, the boys made a study of the approximate wage of the important processes, while the girls collected statistics concerning the number of persons employed and the necessary preparation required of a worker in order to be classed as a skilled workman. Of course, the fact that the workers are unionized was revealed, and, as in the iron industry in the fourth grade, this led to a discussion of factory conditions, hazards of the work, and seasonableness of employment.

The manipulative phase of the work consisted of the making of a small brick in a wooden mould. Each child made a mould and brought in clay for the work. The fact that these hand-made bricks shrank, and were not as large when dry as when wet, led to an interesting discussion as to how much a brick maker must allow for shrinkage. The bricks were not glazed and fired, but the subject of glazing was touched upon and the difference between common, pressed and enamelled bricks was pointed out.

During this study the children kept note-books, so that a definite check was had as to how much they were really learning from the discussions and

readings. Stereopticon slides of other clay industries were also used to aid in impressing upon them the importance of this particular industry.

These brief reports dealing with six distinct units of elementary industrial arts work and study, which were successfully organized and conducted by Miss Hunter, (as well as the several other carefully planned and tried courses, units, and projects that are to appear in the next two articles of this series) were collected for the 1921 Yearbook by the Industrial Arts Committee⁵ of the National Society for the Study of Education. Since it did not prove expedient for the Society to publish Part III of its 1921 Yearbook, which was to have included these suggestive contributions, it has been recommended and urged that, if necessary, this report on promising experiments for developing industrial courses and projects to meet the psychological and social needs of elementary school pupils should be revised for publication in one of the leading current magazines. In order that all concerned might derive the most help from these valuable units and projects, it finally has been decided to present them in connection with the findings and implications resulting from this investigation of 141 public school systems.

While it is encouraging to note these promising results in method and procedure, which tend to show that *we have frequently underestimated the ability of children from 6 to 12 years of age*, it certainly would be unwise at this time to consider any feasible plan for offering elementary industrial arts instruction as more than tentative. These excellent results should at least point the way for further experimentation, which is certain to make more reliable comparisons and measurements possible as the work de-

⁵ This committee was made up of L. A. Herr, G. H. Hargitt, and A. H. Edgerton, chairman.

velops. If elementary industrial arts courses are to continue to occupy an important place in the program for elementary education, these must not only be subjected to the same general tests and judged by the same high standards that

apply to the other elementary school subjects, but the relative possibilities in the different plans for realizing common objectives must be determined more scientifically than heretofore.

(TO BE CONTINUED)

DESIGNING BIRD HOUSES FOR PARTICULAR OCCUPANTS

EMANUEL E. ERICSON

BEFORE an architect begins to work out plans for a dwelling he makes a study of the requirements of the family that is to occupy it. He does not proceed to plan the house for *a* family, but for this particular family's needs and wants. In other words, he consults the people who are to occupy the dwelling to find out what their tastes are, what standards of living they have been accustomed to, whether they want small rooms or large rooms, many rooms or few rooms. No architect could be successful in his profession who failed to take in consideration the requirements of the future occupants of the houses which he designs.

On the other hand there are human dwellings which have been built without any evidence of a previous plan. They are neither beautiful, nor comfortable, nor economical, and were there enough suitable houses in existence, these general ones would be "passed up" for others which had been planned to meet particular requirements.

BUILDING FOR A PARTICULAR BIRD

Many a boy has made bird houses—both at home and in the school shop—and put them up with the expectation that friendly birds would accept his liberal renting offer without delay, but has found to his dismay that when all birds had chosen their summer dwellings, his were left vacant. The reason for this disappointment was largely that the

house was not designed to fit particular needs, and did not suit the requirements of the prospective renters. It was fit for neither bluebird, nor wren, nor martin, nor flicker, nor any other bird which has self-respect enough to require the American standards of living.

A PROBLEM OF DESIGN

Birds, needing only a summer cottage anyway, as a rule, will not accept living conditions as unsuitable as some human beings must. They have been provided for better by nature—they can live in tents, so to speak, and move south for the winter. As a consequence of their advantage, we are obliged to suit their tastes if we desire them as our neighbors.

The boys who would plan and build bird houses with the assurance of having them occupied is in a similar position to the architect mentioned. He must make a study of bird needs and then plan for the needs of a particular bird. This means that if he wants a wren to occupy his house he must not cut the entrance large enough for a blue jay or a sparrow hawk to enter, but he must make it $\frac{7}{8}$ " in diameter so that even the English sparrow is excluded. Or if he will care to try to attract a robin, he will not put in all the walls; for the robin does not fancy having to enter his dwelling thru a hole—he wants to walk erect when entering. Considerable information bearing on the habits and requirements of birds which will make use of

man-made houses as dwellings is now available. Without a study of the subject from the viewpoint of the designer—which is always that of satisfying a need—bird house construction will involve only the squaring of stock and the practice of tool operations, thus depriving the boys of the larger interests and benefits which should come from this activity.

DESIGN IN CONNECTION WITH SHOPWORK

Suppose that instead of handing out blue-prints to the boys in the shop—blue-prints which were made, perhaps, a thousand miles away from the locality in which they are being used—and telling

be possible to attract to this environment. Have them understand that some birds like to build out in the open and want their houses exposed, while others want trees and shrubbery in their surroundings. Give them access to references on this point, and check their conclusions regarding the kind of birds which they expect to attract to the location which they have studied.

(3) Having decided that the environment is suitable for a certain bird, the student may proceed to study the specifications for a suitable dwelling, and work up a sketch. The following references will be found useful here:

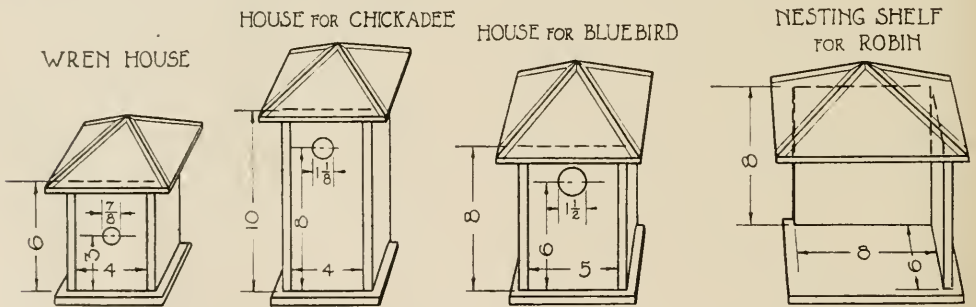

FIG. 1. SKETCHES INDICATING THE NECESSARY CHANGES IN SIZE AND SHAPE OF HOUSES FOR DIFFERENT BIRDS.

the boys to go to work, being extremely careful to use the tools correctly, to square the stock accurately, and to follow the plans scrupulously, that the teacher proceed somewhat as follows:

(1) Talk to the boys about the peculiarities of birds—those birds which are to be found in the particular locality—give out references and reading material so the boys can continue the study after class. The sole job of the teacher here would be to get the boys interested enough to make an investigation and take a lead in further activities.

(2) Suggest to the boys the need of a thoro study of the proposed locations of their bird houses, and have them investigate what kinds of birds it would

Farmers' Bulletin 609 (Bureau of Biological Survey 1917); *Bird Houses Boys Can Build*, by Albert F. Siepert (The Manual Arts Press, Peoria, Illinois); *Attracting Birds About the Home*, Bulletin No. 1 (The National Association of Audubon Societies, 1974 Broadway, New York). A table, which originally appeared in *Farmers' Bulletin 609* and which is reproduced in the other publications mentioned, gives the dimensions required for 27 different birds which will build in ready-made houses. This information is listed under the following headings: floor of cavity; depth of cavity; entrance above floor; diameter of entrance; and height above ground at which to place the house.

THE EXTERIOR OF THE HOUSE

When the correct proportions for the house have been determined, considerable attention should be given to outside appearance, the kind of material suitable for its construction, and the color of the exterior. All these factors are more flexible than those bearing on dimensions, Fig. 1. If the home of the boy is a colonial house, the martin house which is to be put on a pole at the entrance can well partake of the same general appearance, Fig. 2. Or if stucco is used for the home and garage, stucco or certain kinds of roofing makes a suitable exterior finish on the bird houses which are put in open view. On the other hand, some birds—the chickadee for instance—want to be inconspicuous, and requires a house painted in gray or green and put in some secluded spot.

WILL THE BOYS BE INTERESTED?

Not long ago I heard a director of manual arts in one of the larger Mid-Western cities say that he had decided that it would be better to eliminate all woodwork in the schools of that city and use only other kinds of shopwork until a different attitude in the pupils could be developed toward that particular subject. This reminded me of some of my own experience in taking up the responsibilities for the industrial arts work in a small city where the woodwork had fallen into disrepute. Before I arrived, I had a letter from the superintendent saying that manual training was not a popular subject in the school system, and that the only way by which the authorities had been successful in getting an enrollment lately was by purposely arranging conflicts and thus making boys take the work by force of circumstance. Upon examining conditions it was found that there had been a woeful lack of any sort of purpose which the boy could see.

After one year's effort in reorganizing the work and trying to keep the boy in mind, two teachers had to be added to the manual training department and there was a waiting list for some courses.

The argument that has been made that it will not do to spend much time in preliminaries to shop operations presupposes that the preliminaries are not of the right type. If the boy sees the problem or rather, if it is a problem at all to the boy, the time for working it out will not be counted any more than the time it takes to get a rabbit out of a hollow log, or get a kite adjusted so that it will fly.

SEEING SHOPWORK FROM
A NEW ANGLE

With the problem of filling a particular need in mind, the student is likely to go to the shop desirous to do his best to fill that need. He will now work to

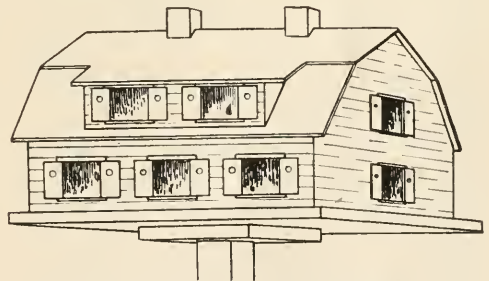

FIG. 2. A MARTIN HOUSE, SHOWING ARCHITECTURAL POSSIBILITIES.

his drawing and specifications not because the teacher told him that he must or his grade would be lowered, but because he is making something which has been designed for a definite end. This gives a new angle to shop operations and makes shopwork easier to teach; design has been brought into play; which is only another way of saying that the student has planned his project to fill a need which he sees and is striving to satisfy.

SUPERVISION OF MECHANIC ARTS

MAX DRUCKER

Instructor in Mechanical Drawing, Bryant High School, Long Island City, N. Y.

AN ARTICLE published some time ago was entitled "Why is a Supervisor?" The question may be answered in a number of ways depending upon the point of view. One statement generally made is that principals may be able to judge and improve the teaching of subjects generally known as the common branches, but that the special subjects are so much more technical in their nature and that the regular teachers are so poorly equipped to teach these special subjects that they require the guidance of a special subject supervisor.

Where teachers are special teachers, supposedly well grounded in the technic of their subjects, we may very well ask "Why is a special subject supervisor for special subjects teachers?" or from the mechanics art point of view "Why have a manual training supervisor for manual training teachers?" Teachers in this kind of work look upon themselves, more or less, as master mechanics; they know their business. Supervisors are expensive. Why have them at all?

There is a very simple answer to this question. Teachers of manual training may be master mechanics but very, very often they are not master teachers. The supervisor must be a man who is a master teacher and an inspiration which will convert teachers into master teachers.

The field of mechanic arts is unique in the fact that its problems are so clear cut. The character of the great body of teachers of mechanic arts is such that supervision in the best sense of the word is urgently needed.

Either by design or because of peculiar circumstances men from the trades rather than men from normal schools have been employed to teach mechanic arts. High school education sometimes has been required, but in many cases this has not

been insisted upon. The general requirements of teachers of shopwork as compared with those for teachers of academic subjects will show how much more in the line of educational foundation must be supplied to the shop teacher after he enters service. Two years of high school as against four years of high school, plus two years of normal school, plus one year of pupil-teaching will leave the shop teacher at a disadvantage in the matter of developing the feeling for educational values as against practical values. Shop teachers are well grounded in their work, but somewhat short on the side of applied psychology and the knowledge of educational aim. It has been said that these men know their subject but do not know the child. Due allowance has always been made for them and when results are satisfactory the means by which they were obtained are not too closely scrutinized. The product, generally the chair or table rather than the by-product, such as honest habits of work and behavior, are given the place of prime importance.

Supervision—the right kind of supervision—must aim to counterbalance this one-sided condition. It must supply the theory which will explain the practice of effective teaching. It must give the teacher a feeling for the larger aims of the work. It must awaken in the mechanic-teacher the desire to know how to teach, in addition to what to teach. It must enable him to distinguish between showing and teaching. It must lead him to experiment in order to find more effective teaching methods. It must give the teacher the ability to judge of the development of the pupil not only by what he produces, but by the habits that are being formed and by the ideals that are being established. Supervision can do all this; supervision that will ac-

comply all this is cheap at any price, even at the price generally paid supervisors of mechanic arts.

There are two classes of mechanic arts teachers that form a large proportion of the staff; the one class, the young men who are "stopping over" in the teaching profession until they can continue their engineering studies, and the other class, the old men "who have arrived," who have given up their trade for the easier and steadier job of teaching. Both of these classes of teachers need supervision in large doses, sugar-coated so as to be pleasant to take, perhaps, but in sufficient quantity to be effective.

The "stop-over teacher" must be made to realize that there is something worth while in the work which requires his best interest and effort. He must be made to feel that the training of the young is a serious problem, worthy of serious study and that the position of teacher of mechanic arts cannot be regarded as a temporary vacation. The supervisors must develop in all young teachers ideals of worth as applied to his own work and to the work of his students. He must establish standards of accomplishment; he must aid in the realization of these standards and applaud the progress of the young teacher toward these ideals.

The older man who has arrived at teaching after a number of years at his trade must be made to realize that his teaching position is not a final resting place. These men are apt to teach year after year with no perceptible change in their work. To them teaching a new class each term is like doing the same job over again from the same plans and specifications and with the same materials at hand. Teaching is not fixed; teaching is alive. The materials are constantly changing and the process of handling the material must constantly be revised. There are new developments every day.

The worth-while teacher will keep in touch with them and assist in carrying them forward by means of testing, experimenting and applying new theories. The supervisor should be the leader and the inspiration in the efforts to keep abreast of the times. He must also be the guide that will control these efforts and keep them in check where checks are needed. He, because of his larger experience, has a broader vision and can give these efforts the direction in which they are to go.

Practically all teachers and especially teachers of mechanic arts require guidance: guidance toward worthy aims, guidance toward self improvement, guidance towards establishing standards of justice, guidance toward effectiveness of method, guidance toward the spirit of helpful co-operation, guidance toward a professional attitude, guidance toward economy of effort, and, above all, guidance toward contentment that comes from the realization of good work well done.

If we have answered the question, "Why is a Supervisor?" we must still answer the question "Who is a supervisor?" Judged by the popularity with the teachers they supervise, it is safe to say that ninety per cent of the supervisors are unfit. Can we, however, determine the fitness of a supervisor by his popularity with the teachers; is this a safe guide? Decidedly, yes. A supervisor who is not welcome in our classrooms, who is regarded as an inspector, who will dissect us and hold up our heinous faults for ourselves and the world to see, who will assume that he knows all and that we know naught, is a repressing influence, a positive danger. To him may be laid a large share of the nervous ailments which have come to be regarded as the vocational diseases of the teaching profession.

Who is a supervisor? Be he supervisor of mechanic arts or of any other subject, he must possess certain well defined qualifications. He must possess tact and sympathy; he must have the ability to call forth the respect and the co-operation of those he supervises; he must know the psychology of human behavior, and be able to appeal to that element in each man which will bring forth spontaneous effort to carry on this work to a successful conclusion. He must know what is to be done, how it is to be done and why it is to be done. He must be able to make his teachers see this. He must establish himself as the source of help to his teachers—the big wise friend to whom the teachers may take their troubles with the assurance that solution can be found there and that it will be gladly given.

Aside from all this the supervisor of mechanic arts must have additional qualifications. He must be a trainer of teachers to a greater extent than other supervisors, because of the qualifications of the available teachers in his field. He must be a man of broad general education. He should know the branches he supervises and the educational possibilities and limitations of these branches. He must be an organizer and an originator because of the continued extension of this kind of work, and he must be progressive and keep in touch with the changes and the developments of this comparatively new and still unsettled phase of educational endeavor.

The supervisor of mechanic arts has a number of specific problems to meet. There are the problems relating to the teachers: His teaching corp is not nearly as homogeneous as to preliminary training and experience as other bodies of teachers. Uniform standards of method and accomplishment and more or less uniform content in the course of study

must therefore be established. The teachers may bring into the system with them the unfortunate attitude which exists in some branches of the trades that it is unwise to share his knowledge with the next man. For this attitude the supervisor must substitute the attitude of co-operation and *esprit de corps*. The teacher must, of course, be given credit for any original bit of information or procedure which is of real worth, but he must be led to spread this among all the teachers.

There are the problems relating to the subject: What branch of the industrial arts can or should be taught in the schools? What parts of these subjects are of greatest educational worth? How can this material be presented so as to make it contribute to the larger development of the child? Shall class instruction or individual instruction be used? What tools may be used by the pupil and what tools would it be unsafe to allow him to use? What degree of perfection must be insisted upon? How can the product be effectively measured? etc., etc.

At every stage of his activities the supervisor will find new and original problems arising from the fact that the subject is new and ever changing. These problems the supervisor or the supervisor and the teacher must solve. The supervisor is the guide. Upon his initiative and resourcefulness, his ability to evaluate, will depend the solution of these and many other problems. Upon him will rest the responsibility for the success or failure of the work.

The supervisor, then, the right kind of supervisor, the guide, the friend, the inspirer, the leader, may be regarded the man of the hour. Let us have him by all means, but let us first make sure that we are rid of the old type of supervisor and that we have the new type.

THE PROJECT RECORD

W. LE ROY BENEDICT

Instructor in

Manual and Mechanic Arts, High School, Cozad, Nebraska

I BELIEVE that it is absolutely necessary for every wide-awake and successful instructor or supervisor of the manual and mechanic arts to have a definite and simple record of everything that is made in the shop, or in the designing room. A successful instructor or supervisor should know every week just what kind of results he is getting from his department. A teacher never knows positively if his work is a success or a failure, unless he knows definitely the results that he is getting in quantity and quality.

A student generally takes home or sells his project after he has made it. Now unless the instructor has a means of keeping a record of the projects made in his department, he soon is mentally at sea as to the number of projects produced by each individual, the time required for the making of each project by each student, the total cost of labor to produce each project, and the total cost of materials in each finished project. It is also highly necessary for the instructor to know exactly, and have on record, all the kind of tools used by each student in the construction of each project.

Every successful instructor or supervisor keeps some sort of project record, in order that he may know at all times the result of student work in his department. But there are many young instructors and supervisors who are not successful at teaching the manual and mechanic arts just because they do not know how to put into practice a little business organization, and also because they are unable to present to their Superintendent or to their Board of Education, from time to time, simple but definite records of the work done in

their department. To know one's department, is to know it well, and records of project work finished, and being finished can not be disregarded.

I am giving below the project record, which I have used with success while teaching in Minnesota and Nebraska. If the reader has no definite project record, let him try this form or a modification of it, and he will know exactly what his department has accomplished from month to month or semester to semester. The instructor or supervisor must remember, however, that to keep a project record of this kind, does not mean extra hard work for him, for the project record is to be made out entirely by each student who is working on a project, after the instructor or supervisor has explained to his students, just exactly how to make out the record. The first six steps of the record and the dimension list of stock is made out by the student when he first begins work on the project. The project record is then handed back to the instructor or supervisor has explained to his students just when he has finished his project, he again obtains his project record and completely fills it out, and also pays for the material he has used. Then the student gives his completed project record to the instructor or supervisor for final correction and to file. The form for these project records is best made on common type-writing paper size 8" by 11". The forms can be printed at any local printing office or very cheaply run off on the school rototype or mimeograph machine. I find that the common letter-filing box that is alphabetically arranged, is satisfactory for keeping the project records.

VOCATIONAL EDUCATION PROGRAM AT THE MEETING OF THE DEPARTMENT OF SUPERINTENDENCE

CHARLES A. BENNETT

TWO sessions of the N. E. A. Department of Vocational Education were held in connection with the convention of the Department of Superintendence in Chicago. These were a little out of the usual, owing to the fact that nearly every speaker whose name appeared upon the program was a city or state superintendent of schools. This was part of the plan of the president of the Department, Wilbur H. Bender, state director of vocational education in Iowa, to attract to the meeting an audience of superintendents. As a matter of fact, the audience of superintendents did not materialize, but most of the speakers did, and they spoke to a good audience of special teachers and supervisors. More than usual, the subjects under discussion had to do with broad general principles and details of administration, rather than with details of courses and methods. On the whole, the program worked out very well because only two topics were assigned for each session, there was plenty of time for discussion, and the supervisors were ready to take advantage of it.

PART-TIME EDUCATION

The first topic was "Part-Time Education." It was frankly admitted by Miss Lulu Auracher, principal of the Continuation School, Des Moines, that not all children are happy to come to continuation school. Why should they be? since "their previous experience in school had given them mental indigestion," said I. S. Noall of Utah. But, he added, "part-time teachers have been able to sweeten the soured attitude." Supervisor Day of East Chicago, Indiana, pointed out that play helped to make the continuation school pupil feel at home. Miss Auracher

said that many girls were held in school by the school activities.

A part-time teacher of ex-service men was quoted as saying, "The ignorance of these men frightens me. They were so illiterate that they could get only a little that was told them and then they twisted it to mean something quite different." When told this, a Federal official replied that he was not afraid of the ones in school, but of the ones just as ignorant who were not in school. This incident was given to emphasize the vital importance of the work of continuation schools from the social and political standpoints. "The opportunity of the part-time school," said Miss Auracher, "is not very considerable except with the right kind of teacher. With the right teacher, it has a great opportunity for service."

K. G. Smith of Michigan would like to see the employers become sharers in giving instruction in part-time schools, and instanced a telephone company in Michigan that gives four hours of instruction a week at its own expense, and under the approval of the local superintendent of schools and the state director of vocational education.

VOCATIONAL EDUCATION VERSUS MANUAL TRAINING

The second topic was "Differentiation between Vocational Industrial Education and General Manual Training or Industrial Arts." This topic was evidently intended to be a "live one," but it proved to be the only "dead one" presented in the meetings of the Department. The first speaker, State Superintendent T. E. Johnson of Michigan, said that education is a single process, that subjects given to students under sixteen years of

age are neither vocational nor cultural but prevocational, that senior high school work is vocational, and that there never could be a dual system because education is a unit.

In the discussion that followed no one took issue with him. Some good things were said, but as a discussion of the topic assigned, they were flat indeed—in fact, they avoided the issue, and it is well they did. This is no time to split hairs and divide, but the time to get closer together. (In fact, I might add that there never was a good time to divide into two camps and fight each other on this question.)

JUSTIFYING ADULT VOCATIONAL EDUCATION

The opening topic of the second session was "Fundamental Problems in Vocational Home Making in the High School." This was well presented by Anna E. Richardson of the Federal Board for Vocational Education and Wylie B. McNeal, state supervisor of home economics in Minnesota.

The final topic of the Department meeting was, "Is Expenditure of City Funds for Evening Adult Vocational Education Justifiable?" Of course, no one expected a negative answer and there was none, but the reasons given were not quite the usual ones or, at least, not in the usual form. Superintendent E. C. Hartwell of Buffalo led in the presentation. After calling attention to the fact that "this country has never dreamed of anything like the present expenditure of public funds"—two or three times as much as three years ago—and that the

people are trying to limit such expenditure, he said, "If an individual really needs a thing he is going to pay for it whether he gets it or not." If he does not pay in the same kind, he does in a different. If he does not pay in money he does in suffering, in privation, or loss of opportunity, or failure to reach the possible goal. "If a city needs adult education it is going to pay for it whether it gets it or not." "Adult education is a well sustained and demonstrated public demand." It is needed. "We must not be unmindful of the great increase in the expense of education, but we must not lean over backwards. I decline to focus all public attention on the expense of the public schools."

Superintendent John H. Beveridge of Omaha was next on the program. Mr. Hartwell had just said that an institution that brings people together for acquaintance is a good common denominator of thought that is needed. Mr. Beveridge said that one of the greatest of our problems is what to do with the leisure hours of individuals who work only seven or eight hours a day. The schools must show such individuals how to spend their non-working hours. Then he added that "*the most satisfying thing in life is the opportunity for self-expression.*" This opportunity the schools can provide thru adult classes.

The same Department officers that arranged this program will hold over until the summer meeting in Boston, so vocational teachers may expect, at least, an equally good program at that time.

I have never seen the advantage of teaching children how to live without teaching them how to make a living

—JOHN CALLAHAN.

THE MILWAUKEE CONTINUATION SCHOOL

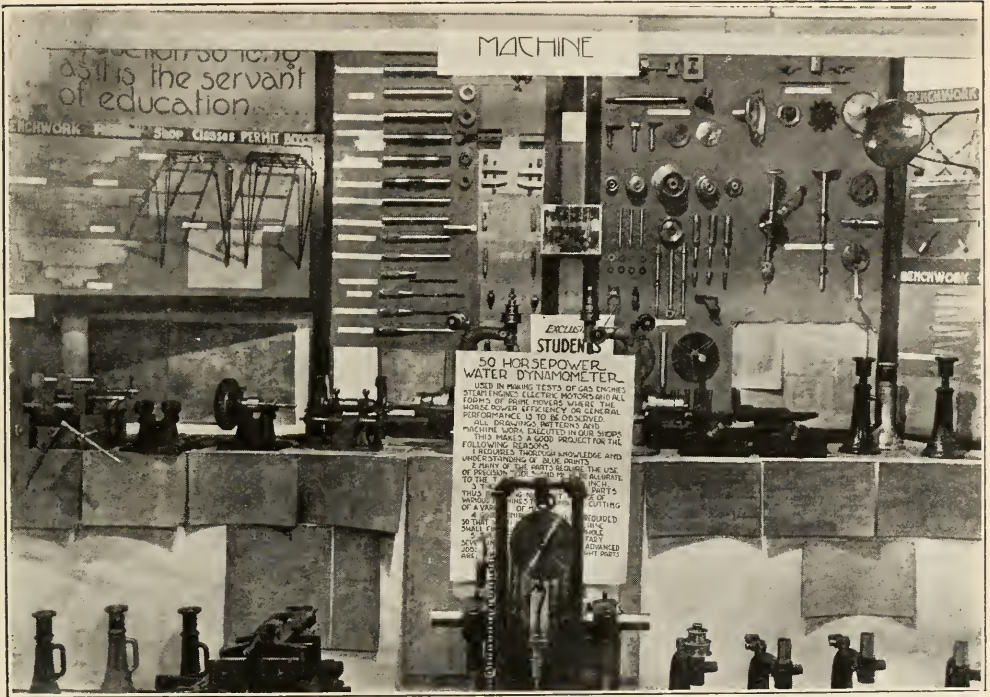
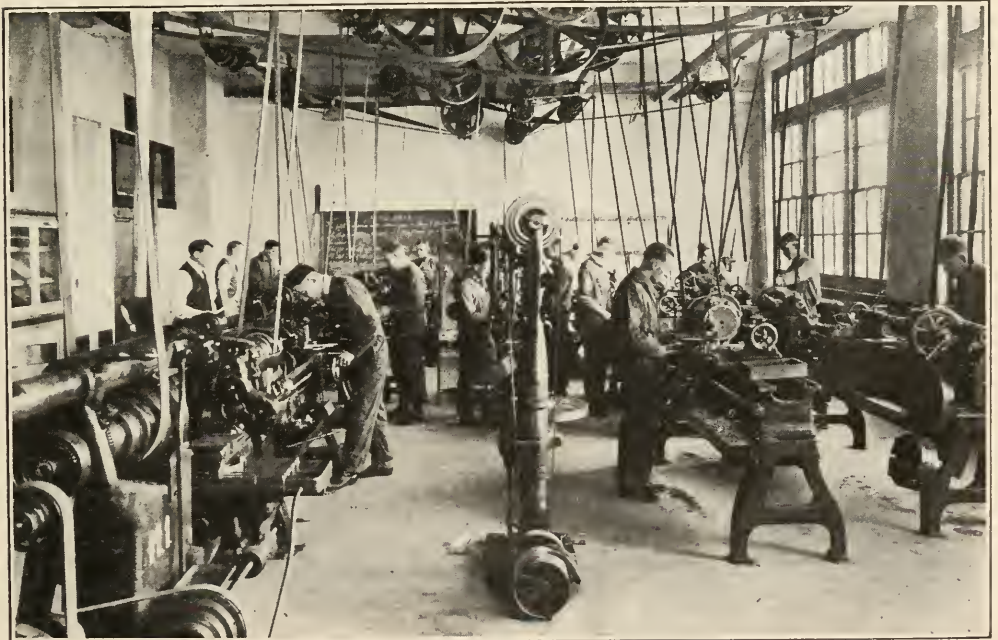

EXHIBIT OF MACHINE SHOP WORK SHOWN AT THE TIME OF THE CONVENTION OF VOCATIONAL EDUCATION ASSOCIATION OF THE MIDDLE WEST



MACHINE SHOP, MILWAUKEE CONTINUATION SCHOOL.

THE MILWAUKEE CONTINUATION SCHOOL



BEFORE AND AFTER IN THE SHOE REPAIRING DEPARTMENT.

PARTS OF A NAILED SHOE



PART OF EXHIBIT SHOWN AT THE TIME OF THE CONVENTION OF THE VOCATIONAL EDUCATION ASSOCIATION OF THE MIDDLE WEST.

THE MILWAUKEE CONTINUATION SCHOOL

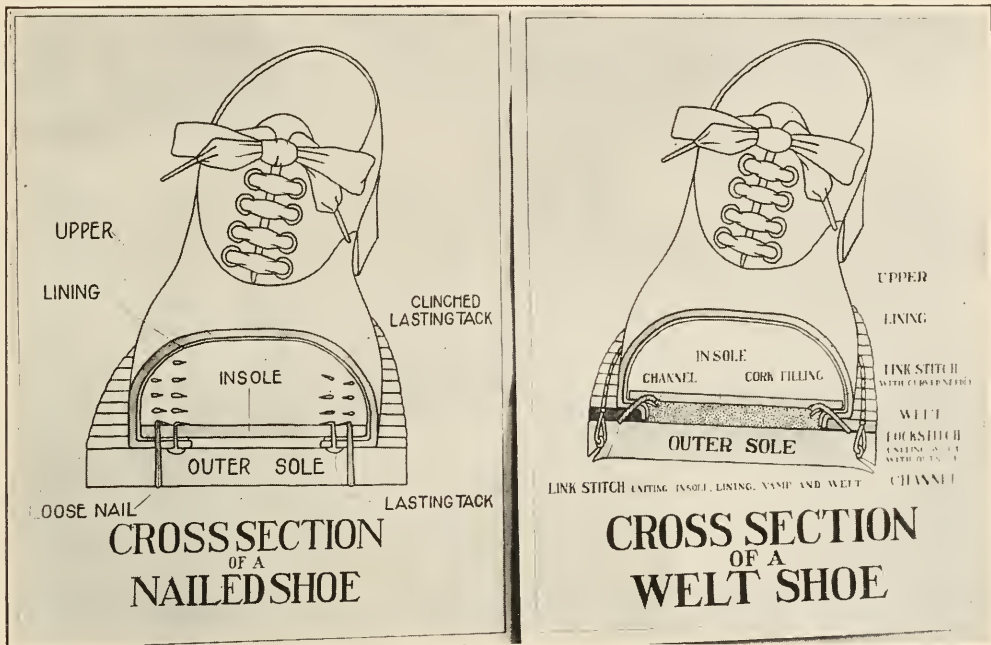

ILLUSTRATIVE CHARTS USED IN SHOE REPAIRING DEPARTMENT.



SHOEMAKING DEPARTMENT.

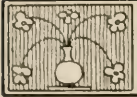

EDITORIAL REVIEW FOR THE MONTH

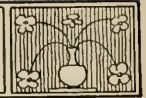

A NATIONAL SCHEME OF ORGANIZATION OF VOCATIONAL TEACHERS AND SUPERVISORS

THERE never was a time when organized co-operation of vocational teachers and supervisors on a national scale was more needed than today. This is said advisedly and with full consideration of the co-operation needed and obtained at the time of the passage of the Smith-Hughes law. The need today is different, but just as great. New problems are at hand, and these are based not merely upon the theory of what should be done, but also and more especially upon experiences in organizing and teaching vocational work during the months since the Smith-Hughes Act became a law. Moreover, these problems are made more difficult by the economic conditions resulting from the World War. Their right solution will require the combined wisdom of the vocational workers of the nation.

It may be pointed out that we already have a national organization for vocational education that did excellent service in helping to pass the Smith-Hughes Act, and that it is doing good service today. This is true, but it is also true that this organization, which at first was supported for the most part by large contributions from men of wealth interested in helping the cause of vocational education, has felt the effect of the withdrawal of these large gifts and has not, on that account, been able to act with such certainty and effectiveness in recent years. It should be added that this withdrawal of large gifts was quite logical after the great original purpose of the society had been accomplished in the passage of the Smith-Hughes Act, and it was also quite logical that the burden of support of the society should be transferred to the men pro-

fessionally interested in the new type of education created by the law. But, the fact that both of these were logical, does not make it any less true that a readjustment of immediate objective and of financial support has made the problem of the society a difficult one.

Meanwhile, there has grown up in the Middle West an organization, full of enthusiasm, which has already accomplished more than its organizers expected. It has kept its membership fee low, thus making its appeal for new members more effective; it has replenished its treasury by securing and keeping the hearty co-operation of the commercial men interested in displaying their equipment and supplies for vocational schools; it has been successful in presenting programs with a sufficient number of new or popular speakers on topics of wide enough interest to keep the attendance growing from year to year, until now it has more than 800 members and an ample working balance in its treasury. It has demonstrated how a regional organization can be developed and maintained at a high standard of efficiency. Moreover, it has done this while the National Society has held its meetings in the territory of the Middle West Association in five out of the six years just passed.

The Mid-Western association was not intended as a competitor of the National Society; many of its most active members are also members of the National Society; but the fact that both organizations have met in the same section of the country so many times has made it necessary for many persons to choose between them when deciding upon their winter programs of conventions. During the past winter, in particular, there has been what amounted to real competition because the dates of the Kansas City and the Mil-

waukee meetings were only a week apart. The result was that the Vocational Education Association of the Middle West drew the larger crowd.

Two propositions seem to stand out as facts:—

First. For the best good of vocational education this competition should not continue.

Secondly. The Middle West association is doing fine work, and should be continued as a regional organization. The meetings of a national organization of the type of the National Society, especially with its new representative system, can hardly be expected to attract the rank and file of teachers from all parts of the country; it must be very largely, so far as attendance is concerned, made up of supervisors and officials of one sort and another. On the other hand, the regional association will attract a larger proportion of teachers, even when both meetings are in the same region, and most surely when the national body meets in a remote region. This seems to be beyond question. Moreover, it is fully believed by many who have studied the question, that a regional association on the plan of the Middle West association is far more inspirational and permanently successful than are the necessarily much smaller state organizations that have been proposed as substitutes for regional societies. With the present state vocational department conferences conducted by state officials it is doubted whether the state is the best unit for the strongest future development. It seems hardly necessary to point out why forty-eight independent and strictly vocational societies would not be as effective in broadening viewpoints, in giving inspiration, in providing an institution which appeals to the teachers as well worth supporting, as

would such regional organizations as the Mid-West association.

If this is true, as we fully believe it is, then the ideal organization of the forces working for vocational education in the United States would be to have several regional organizations—probably from five to seven—covering the entire country. There might be an Eastern, a Southern, a Southwestern, a Northwestern and the Association of the Middle West. Perhaps some other division of the territory would be better.

If this could be brought about, the representative national organization, the present National Society, could hold its convention in turn, or irregularly, with these regional societies. In a measure, it would then be regarded as the guest of some regional society each year. This would not only do away with competition between the National Society and the Mid-West association, but it would enable the National Society to become far more national in character than it is today and it would extend its usefulness. Regional societies would compete for the honor of entertaining the national representative body. And, with five or more vigorous organizations to stand behind the National Society, it could be stronger than ever before, and be better prepared to take the lead in solving the big national problems of vocational education that are before us.

THE ORIGIN OF THE VOCATIONAL EDUCATION ASSOCIATION OF THE MIDDLE WEST

AT ONE of the luncheons held in connection with the Milwaukee convention in January, Albert G. Bauersfeld told the story of the beginning of the Vocational Education Association of the Middle West. He said that one day back in 1914 he and Wilson H. Henderson and William Bachrach had eaten luncheon to-

gether and were standing in front of Henrici's restaurant in Chicago when Henderson, in his characteristic manner, said, "Something must be done about it. Let's go and see Bogan." This was the first definite move.



WILLIAM BACHRACH.

It seems that the idea of forming a Mid-West association was the result of a number of noon-day visits between these three men while they were taking work at the University of Chicago. "The need was felt for a public forum which would be a clearing house for debatable issues on vocational education to meet the requirements of schools located in the states of the Mississippi Valley. While it was recognized that the National Society for Vocational Education was doing pioneering work on the Atlantic Seacoast, there seemed to be consentient thinking that a more intensive program should be carried out in this Mid-West region. At that time there were before us such vital problems as federal aid for vocational education, a unit system or a dual system, conflicting opinions as to

what vocational education would do for capital, labor and the school."

This committee of three waited upon Wm. J. Bogan who immediately agreed to work with them in creating a society. The first meeting was held at the Hotel LaSalle, Chicago, February 5th and 6th, 1915. Thru the co-operation of the *Manual Training Magazine* and other publications a comprehensive mailing list was compiled. A call to arms was sent to all interested in vocational education and the result was a rousing convention with an attendance of about 600. Mr. Bogan was elected the first president of the new organization. Mr. Bauersfeld assumed the responsibility for the finances of the convention. This he accomplished thru the renting of nineteen exhibit rooms at \$50.00 each and thru advertisements in the programs of the convention. Miss Anne S. Davis, now director of vocational guidance in Chicago, was the first secretary. Miss Davis resigned the following year and Mr. Bauersfeld took over her work in addition to his work as business manager. He carried the work of both of these offices for three years, when Leonard W. Wahlstrom was prevailed upon to take over the secretaryship. Mr. Bauersfeld has rendered great service to the Association by remaining at his post as business manager. He has continued his original policy of financing the organization by giving real service to commercial exhibitors on a business basis, and the Association's income from that source has now become more than \$3,000.00 a year. The result of this financing is that the Association is enabled to obtain speakers of national reputation for its conventions, and more recently to inaugurate the publication of a series of monographs on vocational education. Mr. Wahlstrom, even with the greatly multiplied labors of the secretary, has

continued to hold that office to the present time, and at a recent meeting of the Board of Directors, he was unanimously re-elected for the coming year. It is such continuity of efficient service as these two men have rendered that has built up the Mid-West association and will build up any other.

THE NEW PRESIDENT OF THE
MID-WEST ASSOCIATION

THESE historic events are mentioned here in order to give credit to whom it is due and to call attention to the fact that in electing William Bachrach president of the Association for the coming year, the organization has selected not only the man who has been responsible for the building up its department of



LEONARD W. WAHLSTROM

commercial education but also one of the original three men who conceived the Association and gave it its first impulse.

William Bachrach is a graduate of the Chicago public school system, of the Chicago Normal School, of the University of Chicago, and of the Kent College of Law. He therefore holds the

degrees of Ph. B. and L. L. B. He was admitted to practice law in the State of Illinois. At times he has also attended Armour Institute, Lewis Institute and the Central Y. M. C. A. Business School. He taught grade work, manual training, physical training, and commercial work in the Chicago public schools for twelve years. During the past eight or nine years he has supervised the commercial



ALBERT G. BAUERSFELD.

work in the Chicago high schools. He was probably the first city supervisor of general commercial subjects appointed in the United States.

Mr. Backrach has had a rather exceptional experience in organizations and in meeting and working with a great variety of people. He was the organizer, and for five years, the secretary of the Chicago Manual Training Teachers' Club. For two years he was president of the Chicago Normal College Alumni and for one year the president of the Chicago Boys' Workers' Association. He organized the Chicago Board of Education Employee's Band and has been its business manager and secretary for three

years. He was a director of the National Commercial Teachers' Federation for several years. He organized and has been the secretary of the Chicago High School Salesmanship Club since its beginning three years ago. This Club is composed of executives of the largest department stores in the city, and was organized to establish co-operation between the stores and the schools. He was one of the organizers and vice-president for several years of the Employment Advisers' Club, now called the Industrial Relations Club, which is composed largely of employment managers of large firms. He has been chairman of the Educational Sub-division of the Chicago Association of Commerce and chairman of the sub-division at large of the same Association.

With this kind of experience behind him is it any wonder that when the joint meeting with the National Society was held in Chicago, and he was vice-president of the Vocational Education Association of the Middle West, that there developed a saying among the members of the executive committee, "If you want anything in Chicago, Bachrach can get it for you!" All who know Mr. Bachrach realize that he is just the kind of man needed for president of the Association, quite apart from the fact that it was desirable this year to recognize the strong Department of Commercial Education by naming one of its members for president, just as the Department of Agricultural Education was recognized last year in electing Professor J. A. James of the University of Wisconsin. It should be remembered that until last year all presidents had represented industrial education.

ALBERT G. BAUERFIELD AND
LEONARD W. WAHLSTROM

FOR the information of readers who are not personally acquainted with the other two men who have been es-

pecially mentioned as rendering service to the Vocational Education Association of the Middle West, we give the following brief statement:

Albert G. Bauersfeld is a graduate of the Lane Technical High School, the Chicago Normal School, and the Armour Institute of Technology where he received the degree of B. S. He has done special work at Lewis Institute and has done considerable graduate work at the University of Chicago. He taught manual training in the Chicago elementary schools for two years, at the Chicago Normal School for two years, at Stout Institute two years and at the Lane Technical High School for thirteen years. For three summers he did teacher-training work at the Ohio State University. For the past three and a half years he has been supervisor of technical work in the high schools of Chicago.

Leonard W. Wahlstrom graduated at the Moline, Illinois, high school and did his college work at Beloit College, University of Chicago, Cornell University and Teachers College, Columbia University, where he graduated in the course for teachers of manual training in the elementary schools in 1907. He was at one time a teacher and later supervisor of manual training in the grade schools of Indianapolis. Later he was a teacher in the Ethical Culture School, New York City, where he did teacher-training work, giving special attention to methods of teaching shopwork and the development of printing as a school activity. While here he spent three summers in developing manual training in the state of Vermont and later four summers in teacher-training work in the University of West Virginia and one at the University of Illinois. For ten years before the War he was at the head of the Industrial Arts Department of the Francis W. Parker School, Chicago. Since 1918 he has been

in the Rehabilitation Work under the Federal Board for Vocational Education and the Veteran's Bureau. At the present time he is assistant chief of the administration of the Chicago district.

THE VOCATIONAL GUIDANCE CONVENTION

THE National Vocational Guidance Association held its annual convention at the La Salle Hotel, Chicago, February 23 to 25. Prominent in the work of the convention were the president, Miss Helen T. Woolley of Detroit, the secretary, Miss Anne S. Davis of Chicago, and the chairman of the Board of Trustees, Professor John M. Brewer of Harvard University. Among the many speakers were President Walter Dill Scott of Northwestern University; Frank M. Leavitt, assistant superintendent of public schools, Pittsburgh, Pa.; Professor James H. Trufts and Mrs. Anna Y. Reed of the University of Chicago; and Miss Jane Addams of Hull House. On Friday evening the policies of the Association were officially set forth by the president in a very well organized statement.

Mrs. Woolley said that the purpose of the organization was to bring about such conditions in the public schools that children will make a wiser choice of occupation. This would mean certain modifications in present educational practice. She spoke of these under three main headings as follows: (1) The schools must have more accurate knowledge of every child. (2) There must be changes in the school curriculum, including some additions. (3) Our conception of the process of education must be extended beyond the formal school period. Under the first of these she placed mental tests and a system of cumulative records within the school; under the second, changes affecting the treatment of exceptional

children, greater variety of training—wider vocational opportunity, and instruction about all kinds of occupations—not merely facts, but points of view; under the third the importance of keeping the young workers in continuous touch with the schools.

Mrs. Woolley said that the Vocational Guidance Association is primarily interested in general education because the proper guidance must function chiefly thru the public school system.

CONDITIONS OF EFFECTIVENESS IN VOCATIONAL GUIDANCE

ON Saturday morning Miss Grace Abbott, chief of the Children's Bureau, Washington, D. C., discussed the effectiveness of a vocational guidance program in a way that made it an appropriate supplement to the address of Mrs. Woolley. She said it was better for the child when entering industry to have his head filled with fairy tales than with machines and machine processes. She led up to this statement by pointing out that most of the vocational guidance efforts in this country and in Europe have been intended to get children into better jobs. More effort, she said, should be expended in making the job better. "We have a lot of perfectly rotten jobs in this country. These are usually filled by immigrants. If immigration is to be restricted, American children will go into these rotten jobs—and there is an increasing number of such jobs. I am aware of the popular idea of the advantages of a placement bureau, but, if these are all, they are very little." We need to try to make jobs better.

She said that the trade unionist doesn't give much attention to children, nor does the employer. Apprenticeship has been considered with reference to its effect upon "scabbing" rather than upon the children. "Placement bureaus should

control the supply of labor to some extent." Then "we have got to show the employer that we are interested in what happens to the child after he goes to the job." "We must keep in touch with the changes in the program of industry. We need to know not only the tendencies in education, but also in industry." If we know more about the industries, Miss Abbott believes, we will "modify our ideas of preparation for jobs—especially the lower jobs." We will be likely to conclude that learning fairy tales is a better preparation than learning machines.

The list of officers elected for the coming year was headed by Anne S. Davis of Chicago, president; Edward Rynearson of Pittsburgh, first vice-president; Dorothea de Schweinitz, Philadelphia, second vice-president; Elizabeth Cleveland of Detroit, secretary; and Arthur F. Payne of Minneapolis, treasurer.

THE PERSONNEL OF SMITH-HUGHES CLASSES

THE following has been received from Edward S. Maclin, professor of industrial education at West Virginia University. It continues the discussion of a subject that is worthy of still more attention at this time:

In the January *Manual Training Magazine*, Frank C. Vincent makes a strong plea for a square deal for the teacher of vocational subjects so that vocational classes shall not be the dumping grounds for all the school misfits, be these from schools academic, vocational, or otherwise. With his plea all true believers in industrial education should be in hearty accord. The Federal Board for Vocational Education has tried to protect the local teacher against any arbitrary imposition of delinquent students on a Smith-Hughes class. On page 17 of Bulletin No. 1, Statement of Policies, is found this: "XI. Persons for whom vocational education is intended."

"The Federal Board desires to emphasize the fact that vocational schools and classes are not fostered under the Smith-Hughes Act for the purpose of giving instructions to the backward, de-

ficient, incorrigible, or otherwise subnormal individuals; but that such schools and classes are to be established and maintained for the clearly avowed purpose of giving thoro vocational instruction to healthy, normal individuals to the end that they may prepare for profitable and efficient employment. Such education should command the best efforts of normal boys and girls."

The same principle is restated on page 30 in answer to question XX.

No right-thinking individual will gainsay the spirit of this one iota, and the school superintendent who violates it in principle or otherwise does not deserve any aid from any source nor does he deserve to have a true vocational leader on his staff.

The time is not far distant when classes are going to be provided for individuals on the basis of their intelligence. Our tests of general intelligence are becoming so very well standardized that soon the teacher of any vocational subject will rate his pupils on intelligence and those who do not come up to the standard of his trade will be recommended to take one requiring intelligence of a lower degree. If, on the scale of A as high and D as low, a boy of 16 to 18 ranks C, there is no excuse for wasting public money trying to train him for a B grade trade or profession. Such a method of assignment, based on personal interest voluntarily expressed, will solve the trouble advanced by Mr. Vincent. Very few boys 14 to 16 or 18 are so fixed in their minds as to their future occupations but that they can be guided in the choice of a vocation where their grade of intelligence plus their natural interest will enable them to make a fair degree of success in this life.

In every trade there are different degrees of intelligence required for different lines of work. For example: the man who has charge of a steam plant must be of a higher degree of intelligence than is absolutely necessary in the man who handles the scoop in keeping the fires going. In training these two men, the one in charge of the plant would get all that the fireman received plus the additional training which enables him to progress to the higher station in this line of work. It is clearly time wasted to try to train the fireman for the additional duties of engineer when he does not have the intelligence to properly handle the plant. On the other hand, it is just as bad to have a man of high intelligence doing work that a man of lower intelligence can do unless it is necessary in order to progress to the higher levels of the trade. The distribution of intelligence needs to be conserved by trying to get each individual to do the kind of work which he likes and just as high up the scale of industrial performance as his intelligence will permit.

A POINT OF VIEW

A GOOD FELLOW, BUT—

THE lobby of a hotel headquarters of a national convention is not only a place to size up the whys and wherefores of the meeting but it is also the place to get angles on men as well as measures. In the hall itself one may have an expressionless audience which stolidly sits thru the period when the speaker states his "times are changing," "new forces are coming into our school system," "the schools must go to business and not wait" "Let us place our emphasis on the child," etc.

"Great applause," as the audience adjourns to the knockers bench in the lobby. Here the little word "but" has full sway. Brown sits down beside Smith, puts his hand familiarly on the knee of his friend takes a long pull at his cigar, emits a cloud of smoke and says, "Smith what do you think of Bill Jones who spoke tonight?"

The answer comes back, "He is a good fellow, *but*" From this "but" on there is anything from a suggestion that the fellow is a plain ordinary cipher to the implication that he is a candidate for the electric chair. Here are some sample he-is-a-good-fellow-but conversations.

"What do I think of Bill Jones?"
"Well! I'll tell you. He is a pretty good fellow, *but* did you know that seven years ago somebody said (I forget just who it was) that somebody saw him now, of course, there may not be any truth in it, *but*"

Or, "I'll tell you Brown, my opinion of Bill Jones. Personally he is a fine chap, *but*, most of the time he is running on five cylinders and has not found the right mixture in this vocational education business. Of course, I don't claim perfection myself, *but*"

Or, "You have said it Brown. From the way you ask the question I know that you have reason for asking me about Bill Jones. Well, he is all right, *but* I want to tell you that some people are going to find out some day that he never graduated from that teacher training course which he says he did, and that . . ."

Or, "Now I don't want to have my remarks repeated, but as a real friend of mine, Brown, you ought to know about Bill Jones. He is really a mighty good fellow, *but* he needs watching. Now for example"

Or, "You want my opinion of Bill Jones? He is a good fellow, *but* you know he formerly drank. Of course, I don't pretend to be perfect myself, but a school superintendent"

As I have often heard Bill Jones defamed, morally decapitated, professionally electrocuted, and generally consigned to the "demnition bow-wows," it occurred to me for perhaps the first time in my life that the little word "but" has a hidden significance all its own and that its use involved, as a Japanese student once said, "some praise with a faint damn."

I returned from the convention with an early Spring resolution: I will say the worst things I can about a man right at the start, i. e., assuming that it is necessary (which it isn't) to say all the bad things I can; then I will bring in my "but" and say something fine and generous and true. Perhaps I will be fine enough in thought and generous enough in action to soft-petal the harsh things. Anyhow I'll get the bad "buts" out of my system at the start, and ring in the good "buts" as quickly as possible.

For example: "You want my opinion of Bill Jones? Well! I am sorry to say that he drinks like a fish, *but* he is good

to his family, pays his bills, he is the best of friends and minds his own business.

Or, "My notion about Bill Jones?" Well, his knowledge of pedagogy is nil, *but* the way that he can handle that bunch of tough nuts from the river front makes me green with envy."

Or, "Bill Jones, Well! I tell you. To my way of thinking he has a false idea of the purpose of the continuation school, *but* the way those messenger boys crowd around him after he has shown them a wireless receiving set makes me wonder"

Or, finally, "Of course you are right about Bill Jones. He was crooked at one time, *but* I'll tell you that he is going straight now and we ought"

Or, "I tell you that Bill Jones, between ourselves, is no administrator *but* he can handle a school board so that they pick crumbs from his hands and he has the public with him.

Now I am tired of that word "but" unless we use it in the more generous way (assuming that no one is really contented or expects to impress people with his superior judgment of people unless he qualifies always by use of "but").

I am tired of "a good fellow, but." Let's neither "praise with a faint damn" nor "damn with a faint praise." Never "but" a commendatory remark. If we must "but", let's say the worst, and then ring in a hearty "but" of commendation.

—ARTHUR DEAN.

WASHINGTON CORRESPONDENCE

WASHINGTON continues to hold a leading place in the thoughts of the people, because of national and international history which is in the making here, and because of the tremendous importance to everyone of the decisions which are being made, and which yet must be made during the next few months. No one who follows the trend of events can fail to be impressed with the complexity of the situation confronting those who are charged by our form of government with the responsibility for making these decisions.

This is not the proper place to go into these matters, except merely to call attention to the fact that many perplexities beset those to whom we, the people have committed these responsibilities. Well-organized and powerful forces are at work here to exert influence in every possible way. No doubt most of the influence is exerted in legitimate ways, by those who believe that the advancement of the interests they represent is for the good of the country.

The difficulty is that some of the programs thus strenuously advocated are in conflict with one another. At times it appears that certain conclusions and eventualities are at the same time inevitable and incompatible. In some circumstances the situation can be cleared up by securing expression of opinion from elements of the population which are not normally vocal or aggressive in putting forward their views.

PUBLIC DUTIES OF THE MANUAL TRAINING TEACHER

HERE is where education justifies its mission, it seems to me, and makes large demands on every teacher no matter what subject he teaches or what his rank may be. We do not teach manual training, or geography, or chemistry, or Latin primarily, but boys and girls who in a few years will be taking sides on the momentous issues of the day. Any teacher who does not contribute something to the development in his students of the power, *and habit*, of clear, straight

thinking, and the exercise of sound judgment based on thoughtful examination of pertinent evidence, is missing fire on one of the chief obligations of his profession.

The manual training teacher, therefore, should not excuse himself by saying, "I am not interested in politics." It may indeed be permissible for him to subscribe to this declaration in its ordinarily accepted meaning, and it is not incumbent on him as a teacher to be an active partisan campaigner. Nevertheless he should interest himself in public questions, as one of the duties he owes to society in return for the public investment in his own education. He should be known among his boys, as well as among his fellow teachers, as one who is studying such questions as the future responsibilities of the United States in the Pacific, ship subsidies, and adjusted compensation for the boys who wore the uniform, and as one who is trying to form opinions as to the attitude which his representatives in state legislature and congress should take on these and other questions.

MANUAL TRAINING IDEALS ARE BASIC CHARACTER IDEALS

THE manual training teacher is, of course, under no sort of obligation to propagate his own personal conclusions or views on these questions. On the contrary, this must be avoided in the school. Outside of school he enjoys the privileges of any citizen, but because he is also a teacher he must exercise some of these privileges with more than ordinary discretion. It is not only his privilege,

but his duty also, to advocate the intelligent study of these questions, and to offer from time to time suggestions as to source material.

But there is another, and to my mind very important, bearing which the work of the manual training teacher has on his responsibility to the public. The solution of problems in his shop or classroom calls into play certain scientific principles, mathematical laws, the relationship between cause and effect, logical reasoning, and the like. He can render a real service to his students by seizing opportunities to indicate how these same principles and laws find application in the solution of public problems. He can and should make it clear that these are not simply isolated or abstract theories the chief function of which is to furnish material for study in school.

Furthermore, the manual training teacher is continually struggling to build up in his students ideals of craftsmanship, of dissatisfaction with shoddy workmanship, of reliance upon sound construction instead of showy appearance, and so on. These students of today are the world's workers and leaders of tomorrow. Is it too much to hope that some day we may have such wide diffusion of understanding of mechanical principles and of a lively conscience with respect to mutual responsibility that it will be impossible for any one to cover up faulty construction with plaster or defective materials with fresco, and thus lead to the collapse of a building with the resulting loss of life and property damage?

—WILLIAM T. BAWDEN.

INSCRIPTION ON THE FRIEZE OF THE EAST HIGH SCHOOL, CINCINNATI

*To reveal truth and beauty
To develop intelligence and skill
To inculcate social and civic ideals
For a broader and richer personal life.*

—RANDALL J. CONDON.

IN FOREIGN COUNTRIES

DIFFERENCES OF OPINION CONCERNING INDUSTRIAL EDUCATION FOR INDIA

IN FEBRUARY 1921 the Bombay Government appointed a committee to inquire into the present facilities for industrial education and to draw up a comprehensive scheme to meet future needs in India. It seems that the committee was made up of an Indian chairman with five of his Indian colleagues on the one hand and ten European members on the other. As the work proceeded a sharp line of cleavage became apparent between the two groups and so a summary of the conclusions and recommendations have been given out in the form of a preliminary report which is now under discussion.

All the European members represent the management of industries and they believe that their views represent "the emphatic opinion of every employer of labor." Both groups agree that a strong effort must be made to raise the standards of all grades of technical and industrial education and to extend such education as rapidly as industrial and economic conditions will permit. But, as reported in the *Times Educational Supplement*, in the application of this ideal they differ. The European group are convinced that the practical training of boys, youths, and young men should be given whenever possible in workshops and factories under arrangements analogous to the so-called apprenticeship system. The skilled workman can as a rule be efficiently trained in his handicraft only in commercial workshops or by master craftsmen working on their own account. Therefore they do not agree with their Indian colleagues in proposals which would in effect replace the training of skilled artisans in workshops, factories, and under master craftsmen by a training in workshops attached

to technical and industrial schools. They point out that the whole character of technical and industrial education must depend on whether the Government supports this view or that of their Indian colleagues which is that young men can receive an adequate manipulative training in workshops attached to the schools.

The interim report proposes the setting up of middle industrial schools, lower industrial schools, and of supplementary classes or courses in existing educational institutions. In the industrial schools instruction and training would be given, in addition to general subjects, such as languages, mathematics, and science, in mechanics, mechanical drawing, smithy, fitter's work, carpentry; in special trades, and in manufacturing industries.

One of the big questions involved in the discussion is the cost of such schools as are proposed. "Indian financial resources are strictly limited, and to spend money on unsound educational schemes is to encourage, in the long run, reaction from steady progress." The final solution of the problem for India will interest educators in other countries also.

THE CULTURAL AND THE INDUSTRIAL VALUE OF HANDWORK

AT A RECENT meeting of the Educational Handwork Association of England the secretary of the Middlesex Education Committee, B. S. Gott, spoke on "Secondary Education thru Handwork." The following is a newspaper report of his address:

He said that the first steps in educational handwork were no doubt taken in response to the cry that something useful should be taught. Handwork was considered in relation to the promotion of industrial efficiency. It was soon seen, however, to have a cultural and a moral value. In most primary and secondary schools to-day it was taught to children under thirteen or thereabouts as a method, not a subject. Thereafter it became

vocational. There were, both at primary and secondary schools, boys who, voted dull in class, were brilliant in the workshop, and were certainly not below the general level of intelligence. One had to consider the vast body of people needing a good general education to whom the ordinary school curriculum did not apply. For these, handicraft would be of immense benefit—handicraft with a cultural rather than an industrial aim. An institution consisting mainly not of classrooms, but of workshops, would be helpful even to pupils who were not intended for the factory, the object being to provide a good general education in which the use of tools was the means and not the end. The question to be considered was whether they could find in the lathe and the battery a substitute for language and literature, so that there would be no difference culturally between the products of the different types of secondary school.

Teachers of unusual capacity would be needed. They would have to have the cultured outlook of the University man combined with skill in the use of tools. The ordinary craftsman was too affected with the material views of Trade Unionism. The chief advantages of this system would be the discovery of special talents which now lay hidden,

and the prospect of the rediscovery of the spirit of inventiveness.

THE AIM OF JUNIOR TECHNICAL SCHOOLS

AT A MEETING of the Council of the Association of Technical Institutions in England the development and aim of junior technical schools was under consideration, and the conclusions reached were in harmony with the viewpoint of educators generally in America with reference to industrial courses in junior high schools. *The Times Educational Supplement*, in reporting the meeting says in part,

One of the chief recommendations is that these schools should be designated not as preparing for "artisan or other industrial employment or of domestic employment," but as designed to provide a liberal education largely based upon instruction in science and handicraft or commerce, and which may, or may not, prepare for industrial, commercial, or domestic employment.

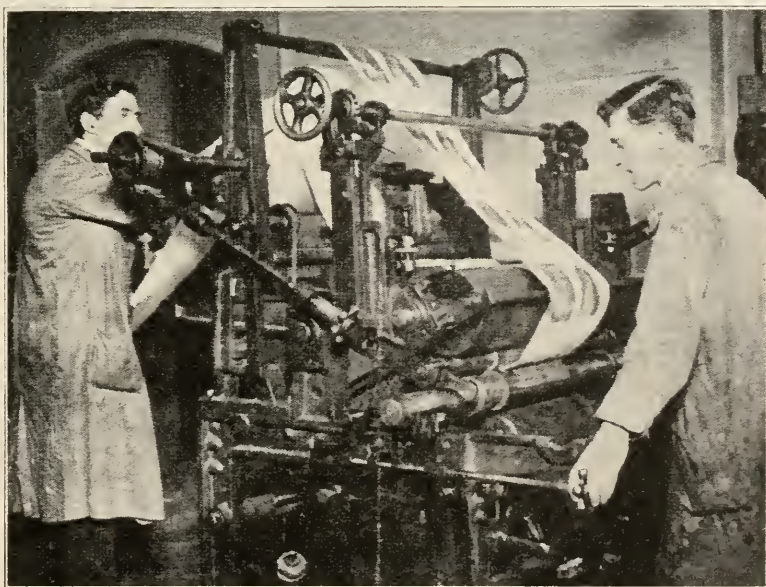

MACHINE PHOTOGRAVURE WORK BEING DONE IN AN
L. C. C. SCHOOL IN LONDON, ENGLAND.



PROJECTS, PROBLEMS AND NOTES

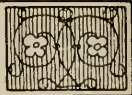
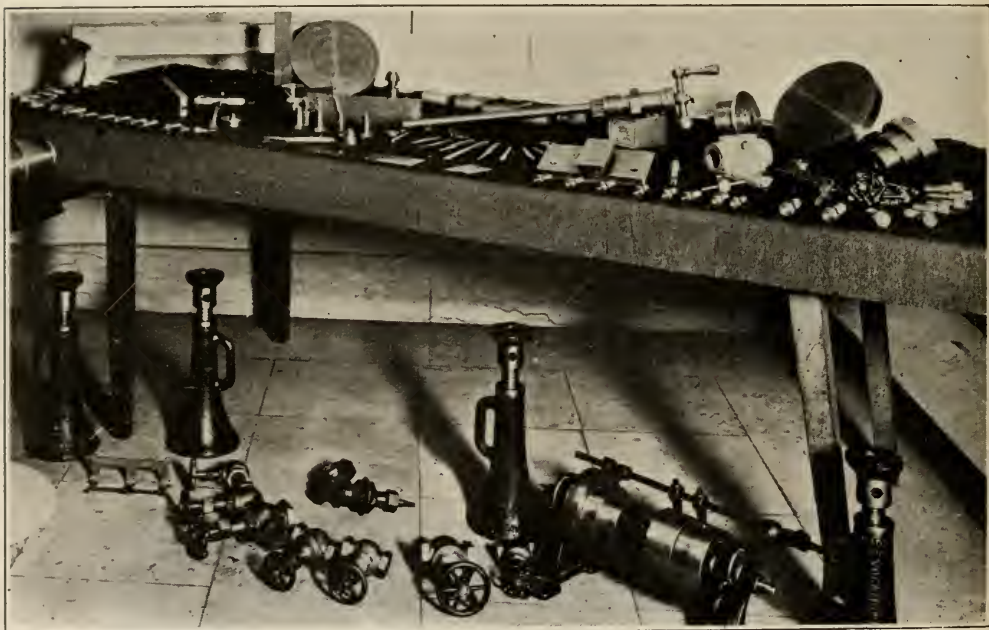

EXHIBIT OF MACHINE SHOP WORK

ACCOMPANYING this item is a photograph of machine shop work taken at the Milwaukee meeting of the Vocational Education Association of the Middle West. It shows part of the exhibit of the vocational school at Green Bay, Wisconsin. When sending us the photograph, Burt Balke, the

of work which for specific reasons must be .875" and has been made .873" is equal to a piece of second hand machinery having had six months or more wear.

"No amount of high finish will compensate for inaccuracies, but accurate work must be thoroly finished. In other words, it must *be* right first and



MACHINE SHOP WORK, VOCATIONAL SCHOOL, GREEN BAY, WIS.

instructor, emphasized so much the importance of thoroughness that we quote a part of his statement:

"All work must be accurately done. No standard but 100 per cent should be even considered. No variations over 1-1000th part of an inch should be permitted to exist in the minds of students as a goal in ordinary work, and no variations over 1-10000th part of an inch for close tool work.

"Of course it is known that many times students do not attain to these standards, and when they fail the work should be immediately scrapped, and in their presence. Schools ought to be standards or models for industries, whereas, they are the tail ends, as a rule, of the whole works, niggardly apeing the industries. When the inspectors in factories making duplicate parts will not tolerate variation over close limits why should a school, which ought to be a model, talk about 64ths of an inch? A piece

must *look* right second. No amount of close work receives its due reward unless it is finished in 100 per cent fashion."

SEWING BOX

Mr. Editor:

This sewing cabinet problem we have been using in the Ottumwa junior high school the last few semesters, and the results obtained have been excellent. I do not claim that the idea is original. It has been modelled on straight lines so that it can be made in the grades as well as high school. Of course, where lathes are accessible turned legs might be substituted. This problem can be used, also, as a "factory plan" problem, and the desired class number made in this way.

I think that the drawing will take care of all necessary dimensions and will not need any ex-

planation. The cabinet, of course, should be made of hard wood, but I have been obtaining satisfactory cabinets with half-inch cypress.

The box should be put together with glue and nails. For finishing, it should be stained the desired color and given four or five coats of shellac. In the case of hard wood the necessary amount of wood filler should be used.

—GLENN H. OSBORNE,
Ottumwa, Ia.

The drawing gives all the detailed information needed for the construction of the rack, which may be made of either $\frac{1}{2}$ " stock or something a trifle lighter.

—F. G. HIGBEE, University of Iowa.

GARDEN TOOL BOX

This is one of the problems that have been found successful in the public schools of Los Angeles, Calif., under the supervision of C. A. Kuncu.



SIXTH GRADE WORK, EAST SIDE SCHOOL, SAGINAW, MICH., WILL J. CRAIG, INSTRUCTOR.

A USE FOR THE EMPTY CHALK BOX

AN empty chalk box provides a convenient sized container for fastenings in the shop: Nails, screws, bolts, nuts, washers, etc., may thus be stored in boxes plainly marked as to size and contents. Moreover, these chalk boxes stack up nicely and make a tidy appearance in the tool-room.

The drawing shows an easily-made and cheap rack for "toting" six of these boxes, arranged in two rows of three each end to end. The rack is light, easily transported, and provides a convenient way for carrying fastenings about. When another assortment of sizes or another type of fastening is wanted the boxes may be removed from the carrier, placed where they belong in storage, and a set of boxes containing the desired type and size of fastening substituted in the carrier.

A DRAWING OF EVERY OBJECT?

Question. Should a student be required to make a drawing of every object before he commences to make the object.—G. C. D.

Answer. No. The carpenter, the brick mason, the pattern maker, the plumber, the machinist and nearly every other mechanic has to work from drawings made by other persons—usually an architect or a machine draftsman. Any vocational course in shopwork should teach students to read standard working drawings by working from them.

The making of working drawings is doubtless a help in learning to read drawings, but only in the elementary stages is it important. In most constructive designing the drawing is made before the object, tho it is often true that the drawing is not complete or correct until it has been tested by its use in construction work.

—C. A. B.

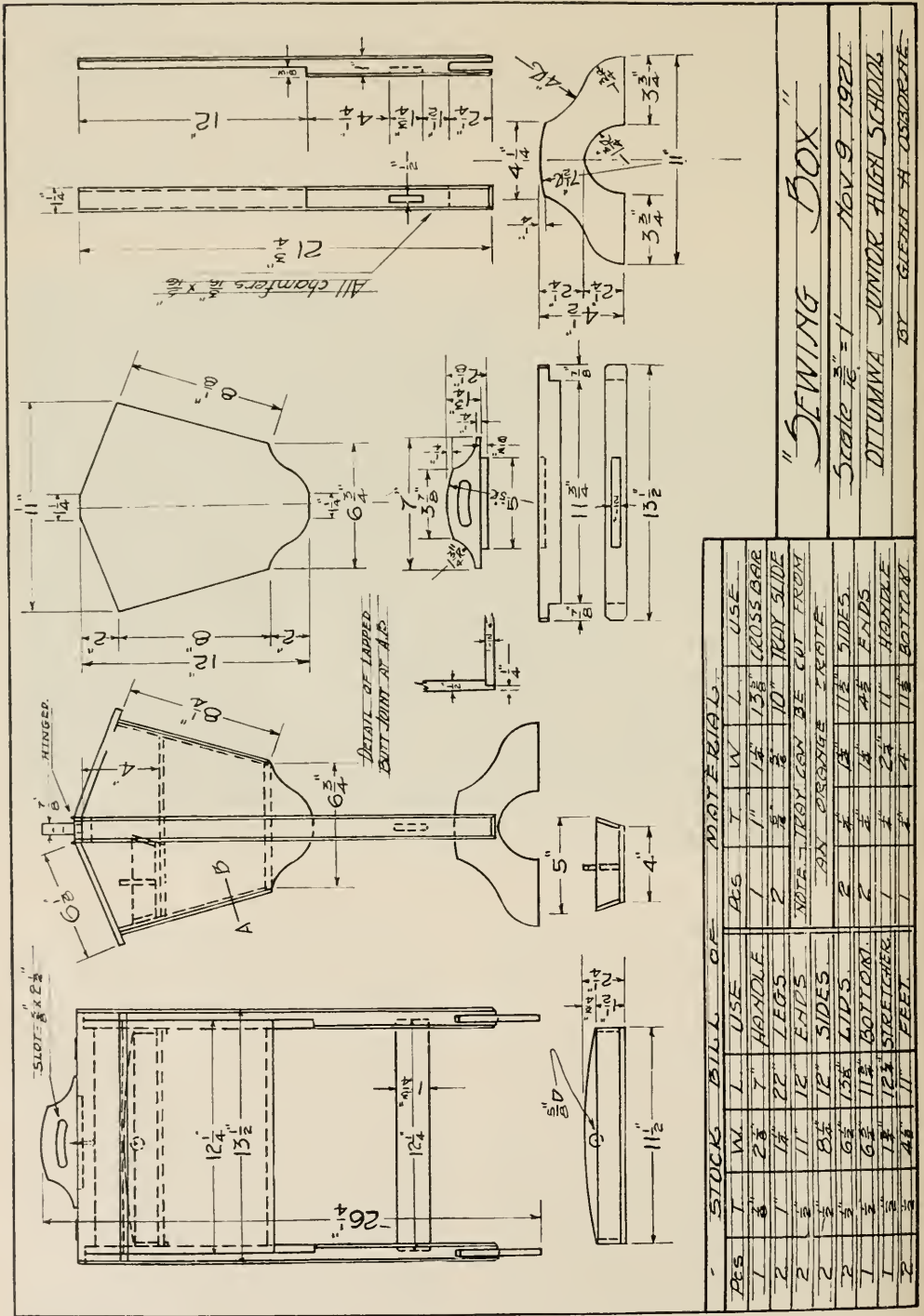

STOCK BILL OF MATERIAL

PES	T	W	L	USE	PES	T	W	L	USE
1	3/8"	2 3/8"	7"	HANDLE	1	1"	1 1/2"	13 1/2"	CROSS BAR
2	1"	1 1/2"	22"	LEGS	2	3/8"	10"	10"	TRAY SLIDE
2	3/8"	11"	12"	ENDS	NOTE: TRAY CAN BE CUT FROM ANY SQUARE PLATE				
2	3/8"	8 1/2"	12"	SIDES	2	3/8"	1 1/2"	12"	SIDES
2	3/8"	6 1/2"	13 1/2"	LIDS	2	3/8"	1 1/2"	11 1/2"	ENDS
1	3/8"	6 1/2"	11 1/2"	BOTTOM	1	3/8"	2 1/4"	11"	HANDLE
1	3/8"	1 1/2"	12 1/2"	STRETCHER	1	3/8"	1 1/2"	11 1/2"	BOTTOM
2	3/8"	4 1/2"	11"	FEET					

"SEWING BOX"
 State 1/8" = 1' Nov 9, 1921
 OTTUMWA JUNIOR HIGH SCHOOL
 BY GLENN A. OSBORN

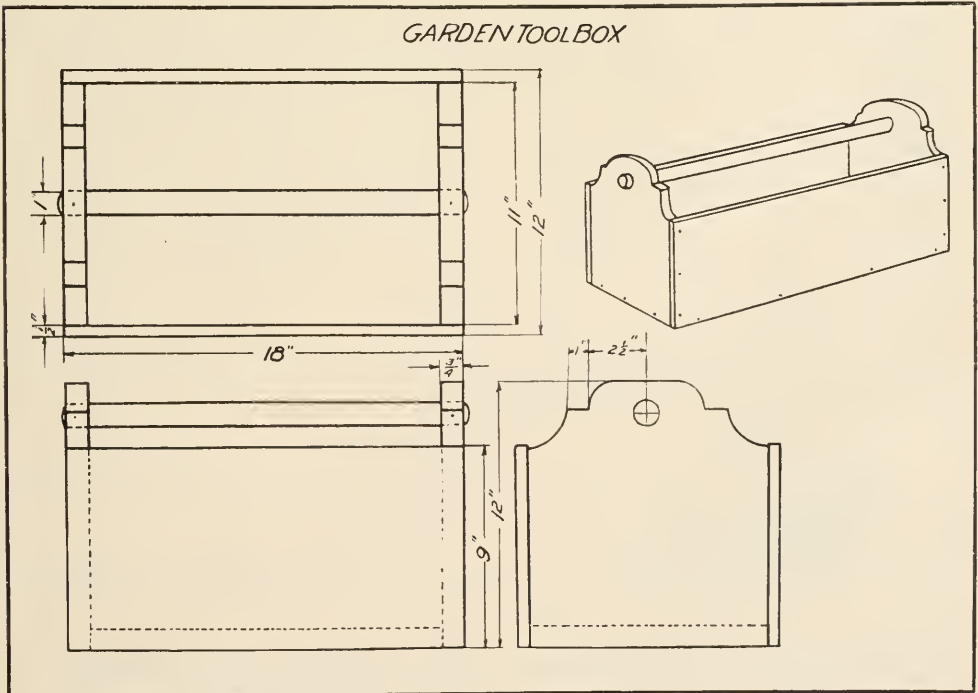
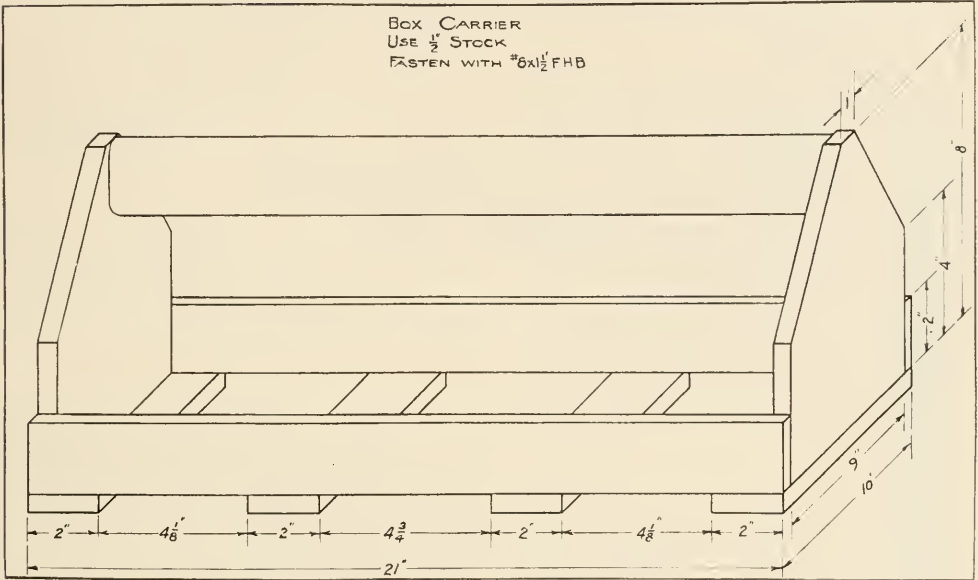

CURRENT PUBLICATIONS

The Foreman and His Job. By Charles R. Allen. J. B. Lippincott Company, 1922. Size, 7½ x 5 in.; 526 pages; price, \$3.50.

This is a companion volume to *The Instructor, the Man and the Job* by the same author. It is a handbook for foremen and for leaders of foremen's conferences. In this book Mr. Allen has brought his unique experience to bear in making an analysis of the job of a foreman in an industrial plant. It treats the subject in detail, discussing the responsibilities of foremen and their relations to the management and to the working force, and especially emphasizing the importance of the human factor. Then the book proceeds to discuss the instructing side of the foreman's job. The book would seem to foreshadow a time to come when foremanship will become a profession, or something approximating it. At least, it will be a more scientifically defined job.

Mechanical Drawing Problems for the Chicago High Schools.

Prepared by a committee of mechanical drawing teachers under the direction of Albert G. Bauersfeld, supervisor of technical work in high schools. Published by the Board of Education, Chicago.

These problems appear in four pamphlets—one for each half-year for the first two years. There is nothing strikingly new about these problems or in their method of presentation. On the other hand, the course is progressively conservative and represents what is generally regarded as the best type of problems for students of this age. The technic is excellent and the drawings are well reproduced.

Opposite each page of problems are notes for the use of students. It is a noticeable fact that these little books are free from the personal idiosyncracies that have characterized some books on this subject. It is clear that an effort has been made to boil the great volume of possible material down to common essentials and then leave the individual teachers to exercise their own personal ideas in teaching the course. The books presuppose that trained teachers will be in charge of the classes.

Farm Blacksmithing. By John F. Friese. The Manual Arts Press, 1921. Size 7⅞ x 5⅜ in.; 92 pages, 30 full-page plates of working drawings and 57 illustration figures. Price, \$1.25.

A textbook and problem book combined, intended for students in agricultural schools and colleges, community high schools, and also for farmers to use at home. It is intended to meet the need for brief yet clear and sufficiently comprehensive description of the several processes most common in blacksmith work on the farm, and consequently in a school for men who are, or are going to be, farmers.

The general scheme of the book is to give a clear dimensioned working drawing of some typical common problem, and then, by means of the text and the illustrations, to tell just how the object may be made with the simple equipment of a farm blacksmith shop. Added sections give special information concerning iron and steel, and hardening and tempering.

Stenquist Mechanical Aptitude Tests. A manual of directions. By J. L. Stenquist. A 21-page pamphlet issued by the World Book Co., Yonkers-on-Hudson, New York. Discusses the purpose and use of the special tests that have been developed by Dr. Stenquist.

RECEIVED

New Spelling Notebook published by the Music Memory Game Company, Chicago. One page is devoted to a word. Space is left for its syllabication, derivation, definition, for its derivatives, synonyms, and for its use.

The Case for the Low I. Q. By John L. Stenquist of the Bureau of Reference, Research and Statistics, public schools, New York City. Reprint from the Journal of Education Research, November, 1921.

A Week's Food for an Average Family. By Carolyn L. Hunt, Specialists in Home Economics. Farmers' Bulletin No. 1228. Issued by the U. S. Department of Agriculture, Washington, D. C.

Agricultural Education. By C. B. Jarvis. Bulletin No. 40, 1921. Issued by the Bureau of Education, Washington, D. C.

Educational Work of the Boy Scouts. By Lorne W. Barclay, Director of Department of Education, Boy Scouts of America. Bulletin No. 41, 1921. Issued by the U. S. Bureau of Education, Washington, D. C.

Wisconsin Journal of Occupational Therapy. Elsa Dudenhofer, 654 Mineral St., Milwaukee, Wisconsin. A new magazine which will be of special help to teachers in this new field of educational effort.

The Story of the Bath. By Edwin L. Barker. Published by "Domestic Engineering," 1900 Prairie Ave., Chicago, Ill.

Public Education in Kentucky. A report of the Kentucky Education Commission. Published by the General Educational Bureau, 61 Broadway, New York.

Child Care and Child Welfare. Prepared by the Children's Bureau in co-operation with the Federal Board for Vocational Education. Bulletin No. 65. Issued by the Federal Board for Vocational Education, Washington, D. C.

LUMBER

JOSEPH H. DION, Pres. & Treas.
EDWIN C. SALVESEN, Secty.
F. FRED TAYLOR, Vice Pres.

Maisey & Dion
Hardwood Lumber



OFFICE AND YARDS.
2349 TO 2423 S. LOOMIS ST.

TELEPHONES: | CANAL 1830
| CANAL 1831
| CANAL 118

CHICAGO.

Dear Manual Training Supervisor:

Is lumber buying one of your WORRIES?

If so, why not eliminate the wear and tear on your nervous system by ordering from us?

During the past seventeen years we have taken care of an ever increasing number of schools to their complete satisfaction.

Our stock includes lumber of all kinds, grades and sizes to meet school needs.

No filling orders in a slipshod or haphazard manner in our institution.

Our yard superintendent exercises close supervision over the SEASONING, KILN DRYING, INSPECTING, MEASUREMENT, AND SHIPMENT of all orders. This insures you mighty good value.

We do not issue stock nor price list, each order is given individual attention. Please advise number of feet and kind of lumber wanted and we will gladly quote you.

Awaiting the opportunity of serving you, we remain,

Respectfully,

MAISEY & DION

J. H. Dion Pres.

MAISEY & DION — HARDWOOD LUMBER
2349 to 2423 South Loomis Street
CHICAGO

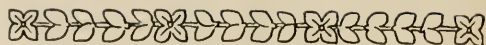

FIELD NOTES—(Continued)

Do not forget the dates of the great convention, Cincinnati, May 2, 3, 4, and 5, 1922.

A descriptive booklet can be had by addressing Louis R. Abbott, 234 North Division Avenue, Grand Rapids, Michigan.

OKLAHOMA MANUAL ARTS INSTRUCTORS' CONFERENCE

A state meeting of the Manual Arts instructors in Oklahoma convened on February 9, 10, 11 in Oklahoma City, in joint meeting with the sixteenth annual convention of the Oklahoma Education Association.

Among the speakers that appeared before that body of men was Chas. W. Briles, state director of vocational education of the state of Oklahoma, who spoke at length relative to the work that has been done in the state under his supervision. Mr. Briles has conducted classes in many parts of the state, especially in the oil and coal centers, along the line of foremanship training. He cited many instances of the success that this type of training has met with, and stated that there is a great future for the man well prepared in this line of work. It is the intention of Mr. Briles to have conducted in this state, at A. & M. College, Stillwater, this summer, a four weeks course in the training of men in vocational education under the Smith-Hughes aid. A large number present expressed their desire to attend this conference. Mr. Briles will be assisted by Professor DeWitt Hunt of Stillwater, and other experts along this line of work.

Mahlon C. Courtney, director of manual arts, Chickasha, and Professor John F. Lance, State Teachers College, Weatherford, read papers on the need of a course of study in manual training. Mr. Courtney made the statement that, a course of study would be an aid to both students and teachers and would bring the high schools closer together. Mr. Lance's paper threw stress on the course of study that would cover prevocational, or finding courses. These courses would be arranged so as to give the student a short course in the many vocations within a period of two years in the high school.

The subject of mechanical drawing was discussed by A. E. Phillips, Oklahoma City, relative to the type that should be taught in the grades, while F. C. McCullough, Tulsa, outlined the course that would meet the demands of the high school. Both of these men have had many years of experience in the trade world as well as in the schoolroom, and in supervision of this subject. These papers



SIMONDS SAWS

Expert mechanics and finest crucible steel make Simonds Saws the best that can be found. Whether it be Band, Circular or Hand Saws you require for the school shop, you will save money and get better results if you equip with Simonds.

They are edge-holding saws that retain their tension and cut fast and smooth.

Write for Catalog

Simonds Manufacturing Co.

"The Saw Makers"

Fitchburg, Mass.

Chicago, Ill.

5 Factories

12 Branches



PRANG - *the mark of perfection in school paints and crayons*

FOR eighty-seven years American Crayon Company products have stood the severe test of universal usage in the schools, playing an important part in the development of school art work.

Prang School Water Colors—manufactured by the American Crayon Company—contain from ten to twenty per cent more color value than any others. Leading color experts say that there have never been any better school water colors than those of Prang. Prang Tempera Colors—opaque water colors which may be had either in jars or tubes—are true and noteworthy for their brilliancy. Particularly adapted for problems in stick printing, toy painting, decorative design and poster work, they are one of the most popular art mediums in the American schools.

Prang Crayograph, a hard, pressed crayon, is an artist's crayon designed for school use. Exceptionally true in color, it gives a flat tone to the drawing. Containing only enough

wax to make it clean to handle, it is far superior to any wax crayon.

Prang Crayonex is the finest of all wax crayons. The colors are brilliant, waterproof, and blend remarkably well for a wax crayon, giving beautiful effects of oil colors. Prang Relievo—a relief paint for decoration—is the newest of the long line of American Crayon Company products. With it can be obtained the beautiful relief effects achieved by the ancient artists. It is an old Venetian formula developed for the use of modern students, designers and craftsmen. Prepared in nine colors and natural, Relievo offers the great advantage of producing color and relief at the same application. It is particularly adapted for school use, for the work may be stopped at any point without injury to the problem. It may be applied to almost any surface. The equipment is small and inexpensive as a small amount will cover a large surface.

Send for Free Copy of the American Crayon Company's New School Material Catalog

▼ *The* ▼
AMERICAN CRAYON COMPANY
SANDUSKY · OHIO ▼ ▼ ▼ ▼ ▼ NEW YORK

Established 1835



**Are
You Using the
French
Drawing Series?**

There is just one reason for the great success of the French Drawing Series—teachability. These books anticipate the troubles of teacher and student—they are based on wide experience—and they have all been thoroughly tried out in class work before publication. Of the latest number in this series—FRENCH and TURNBULL'S LESSONS IN LETTERING—Industrial-Arts Magazine says, "The books appeal to us as the most readily teachable lettering books produced up to this time."

FRENCH and TURNBULL—
Lessons in Lettering. Book I—Vertical, Book II—Slant. 35 cents each; per doz., \$3.60.

A series of practice books with text, examples and exercises. Already in use in 55 schools and colleges.

FRENCH and SVENSEN—
Mechanical Drawing for High Schools, \$1.50. More widely used than all other books of its kind together. Write to us for a list of the schools in your state that are using French and Svensen.

FRENCH and IVES—
Agricultural Drawing and Design of Farm Structures, \$1.75.

FRENCH and MEIKLEJOHN—
Essentials of Lettering, \$1.50.

FRENCH—
Engineering Drawing, \$3.00.

FREE EXAMINATION COUPON

McGraw Hill Book Co., Inc.
370 Seventh Ave., New York

You may send me on 10 days' approval

.....

I agree to pay for the books or return them, postpaid, within 10 days of receipt.

Signed

School

Official Position

Address

.....

M.T.M. 4-1-22

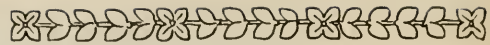

FIELD NOTES—(Continued)

were highly appreciated by the members present, due to the fact that each was a master of his subject and knew what was needed in the average school system in the state.

The subject "What Should be Taught in a High School Automobile Repair Course?" was brought out in a paper well presented by W. C. Bender, director of shops, University Preparatory School.

C. A. Parker, head of the printing department, Oklahoma City read an interesting paper that showed much preparation. Mr. Parker is starting this subject in the high school this year, in Oklahoma City.

"In What Form Should a High School Course of Study be Prepared?" was discussed by Professor L. K. Covelle, Stillwater, who has had charge of the woodworking department in the A. & M. College for a number of years, and from his own experience he gave an interesting discussion relative to his subject.

Officers elected for the coming year were: President, O. M. Martin, director of manual arts, Shawnee City Schools, Shawnee; Secretary-Treasurer, Harry W. McKimney, head of woodworking department, Oklahoma City High School, Oklahoma City.

—HUGH NORRIS,

Director of Manual Arts, Teachers College, Ada, Okla.

FROM MINNESOTA

The many friends of G. A. McGarvey, state supervisor of industrial education, will regret to learn that he is leaving the state department on April 1. They will be pleased, however, in knowing that he may accept a new position with the Federal Board. Details and particulars of the new position are not yet available.

NEW ARTS SOCIETY ORGANIZED

At the last sectional meeting of the Department of Drawing and Design of the Minnesota Educational Association a motion was unanimously

Our New Price List Is Out

It has been greatly extended. No matter where you are located there will be something you must need, either in lumber, panels or veneers.

If you have not received copy write us at once.

Frank Paxton Lumber Co.
Kansas City, Kansas



*Ancient
Greece
Haber*

There is but one master drawing pencil. Some day you will try it, and then, forever after, one name will come quickly to your mind when you think of the best pencil you have ever used. And that name is

DIXON'S ELDORADO

"the master drawing pencil"

To Art Supervisors and Teachers:

Send name, position and address for sample set

Joseph Dixon Crucible Company, Pencil Dept. 19-J, Jersey City, N. J.

Canadian Distributors: A. R. MacDougall & Co. Ltd., Toronto.

A Question

*Are your
pupils
using it?*

The samples will show you why they should.

MADE IN U.S.A.
DIXON'S "ELDORADO" - the

OUR NEW
CATALOG
OF
TOOLS
AND
BENCHES

WILL BE READY
IN A FEW WEEKS

We would like to register
your name for a copy.

Simply mention
Catalog No. 235

Since 1848 we have adhered to
one policy—to handle only
the very best in quality

**Hammacher
Schlemmer & Co.**

Hardware, Tools and
Supplies

New York Since 1848
4th Ave. and 13th St.

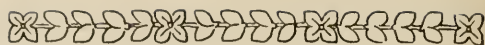

FIELD NOTES—(Continued)

carried that an independent organization fostering art in its every relation to the National life be formed in this state. Officers were elected and chairmen of committees appointed.

The first meeting of this new society was held at the Elk's Club, Minneapolis, on March 14. After a dinner, talks were given by Miss Crawford of the McMartin Advertising Agency, and Mr. Harry Rubins of the John Bradstreet Co., president of the State Art Society. This new organization is worthy of support, and is similar in nature to others in various states.

MR. KAVEL LEAVES DUNWOODY INSTITUTE

To some people in Minnesota the resignation of H. W. Kavel as assistant director of Dunwoody Institute will no longer be news. To many throughout the state and the North it will still be news. Mr. Kavel has been prominently identified with the work at Dunwoody Institute since it was started in the old Central High School building in 1914. He served successively as principal of the school, as assistant director before the war, as acting director during the war, and as assistant director since that time. He took an active part in meetings of vocational teachers on many occasions, was always an active member of The Vocational Education Association of the Middle West, and helped institute and push the Vocational Conference at the annual meeting of the Minnesota Education Association.

He will be associated with E. W. Cameron in the Cameron-Kavel Agency, general agents, in the future. His many friends wish him well in his new enterprise.

NEW COURSE OF STUDY IN INDUSTRIAL TRAINING

A committee appointed by the State Department of Education of Minnesota, consisting of George K. Wells, Homer J. Smith, John F. Friese and Geo. A. McGarvey, are working out a proposed

"JORGENSEN"
PEERLESS HAND SCREWS

A single clamp will adjust to any of these positions or any modification of them.

Steel Spindles
Steel Nuts
Hard Maple Jaws

**Adjustable
Clamp Co.**

216 N. Jefferson St., Chicago

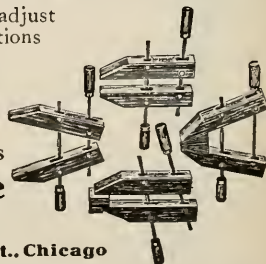

CUSHIONS



Stuffed Cushions
Spring Cushions
Upholstery
Supplies

Write for Descriptive
Circular and Complete
Information for ordering

Illinois Valley Awning and Tent Co.

Formerly Kunkle-Karl Co.

102 S. Washington St. Peoria, Ill.

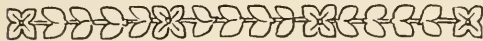

FIELD NOTES—(Continued)

course of study in general industrial training to take the place of the present courses of instruction in manual training and mechanical drawing in the high and graded schools of Minnesota.

Manual training under this new plan will be designated as *general industrial training*. This does not mean, in any sense, that the manual training courses as suggested by the committee, will be of a vocational nature. The aims and purpose will be that of giving general education.

The committee will suggest outlined courses for one, two, and three teacher departments and will include besides courses of instruction, arrangement of rooms and equipment for carrying on this type of instruction. It is hoped that the work of this committee will be completed so that the courses of instruction will be available for the new school year.

INDUSTRY FOR THE BLIND

The Re-education Division of the Minnesota State Department of Education has in its employ a blind man who is investigating the possibilities of placing blind people in industrial plants. This blind man is trying out various operations in such

Give Your Pupils SHOP-WORK THAT PAYS

Let the Boys Build Phonographs

Imagine the pride and joy of your pupils in building *their own phonographs* (equal in quality to high-priced standard machines) either to sell or take home as a source of lasting pleasure. Think how this project will add to your popularity as an instructor. Building phonographs is easy, by our methods, yet it demands precision and delicacy of workmanship, the very points always emphasized in shop practice.

Send 10c for fine illustrated catalog

and full information about our co-operative plan for manual training teachers. We plan the work for you. We supply blueprints, tone-arms, motors, case material and all accessories at lowest prices. Detailed instructions furnished. Materials best obtainable, fully guaranteed. Our machines play any make record. Write us TODAY.

HOOSIER MANUFACTURING & SUPPLY CO.
PHONOGRAPH SUPPLY DEPT.

315 Baldwin Block, Dept. A.

Indianapolis, Ind.

The Student Needs Printing

as much as he needs the alphabet

Q It is as much a part of Education as English, the Rule of Three and History. It is, in fact, a combination of all studies—a practical illustration of all the student learns from teachers and books. It is at once a science, an art and an occupation. It gives him manual, mental and moral training. It helps him form habits of industry, accuracy and taste. It is a joy to the learner and a splendid asset in every relation of life.

Q We supply printing outfits for schools, and give the benefit of our experience and that of schools which have tried out the plan. No school is complete and doing its best work, or near its best work, unless printing is a part of its equipment.

Q Send to us for help in your problem.



Barnhart Brothers & Spindler

Type Founders

Chicago Washington, D.C. Dallas Saint Louis
Kansas City Omaha Saint Paul Seattle

SAW TABLES

For Manual Training

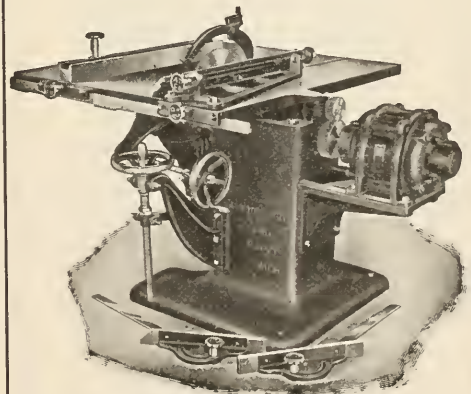

This cut shows our motor driven spiral gear saw table. No countshaft, no belts. Tilting or stationary tops. Write for circular and prices on our entire line. Address

ALEXANDER DODDS CO.

451-453 Monroe Ave., N. W.

GRAND RAPIDS, MICHIGAN, U. S. A.

In Gt. Britain: OLIVER MACHINERY Co., Manchester, Eng.

STANLEY NAIL HAMMERS

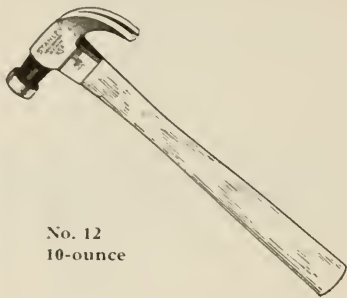

No. 12
10-ounce

Like all Stanley Tools, Stanley Hammers are scientifically made and of enduring quality. Of special steel, carefully forged, hardened and tempered. Handles are selected second growth white hickory. And the claws are designed to bring the pulling strain on body of claw—not on the edge.

No. 12 (shown above) with bell face, round neck and poll, is a popular Hammer.

*Hardware Dealers sell Stanley Tools.
Write for No. 34 Catalog.*

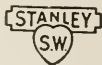

The Stanley Rule & Level Plant

THE STANLEY WORKS

NEW BRITAIN, CONN.

New York Chicago
San Francisco Los Angeles
Seattle

*Manufacturers of Wrought Hardware
and Carpenters' Tools*

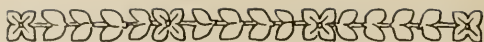

FIELD NOTES—(Continued)

industries as garment factories, auto repair shops, knitting works, paper box factories, small machine parts factories, candy factories and ice cream plants. It is hoped that at the completion of this experiment, at the end of six months, that a report can be made of the possibilities of training blind persons in industrial operations outside of the usual work shops conducted solely for the blind.

This experiment is being carried out in co-operation with the Societies for the Blind of the cities of Minneapolis, St. Paul and Duluth. Splendid co-operation is being given by plant managers and foremen.

—JOHN F. FRIESE.

ITEMS OF PROGRESS

TRADE-SCHOOL STUDENTS BUILD DWELLINGS

The students of the Bridgeport Trade School, Bridgeport, Connecticut, are building this year a six room, two-story dwelling which will be completed in every detail by them with exception of masonry and plastering. The policy of the school is to build one house each year in order to give practical work to the students in carpentry, electricity, plumbing, painting and decoration, etc. The students make out plans, specifications, and estimates for the entire job, and study related problems in connection with the work in construction. This is the eighth dwelling which has been built by this school. The size of the house and the design have been varied from year to year.

JANESVILLE, WISCONSIN, EXTENDS VOCATIONAL PROGRAM

A new high school building which provides unusual opportunities for a vocational and industrial program has been completed at Janesville, Wisconsin. Provision has been made for machine shop practice, auto-mechanics, sheet-metal work, electrical work, printing, cement and concrete construction, woodwork—including pattern making and cabinet making—and drafting. The building is so designed that cars can drive into the auto-mechanics shop and from there into the machine shop. Sheet-metal benches and forges are located in the same room as the machine-shop equipment so that a class can use the different types of tools and machines as the work may necessitate. Ample office and store room has been provided. The school is both a junior and a senior high school. It offers the opportunity for junior high-school students to receive a broad vocational experience while the students of the senior high school have opportunities to specialize in some particular vocational work. J. M. Dorrans is the director of vocational education at Janesville.



THE LIGHT RUNNING TANNEWITZ TYPE "G"

is cutting costs and increasing production in many high grade establishments because of its special improvements.

Solid And Durable.

Frame is an extra large one-piece casting giving extreme rigidity and long life.

Light Running. Aluminum rim wheels, with steel spokes, and ball bearings if desired.

Tilting Table Heavily Ribbed. Adjusts 45 degrees to right, and 5 degrees to left on dovetailed hinges, adjustable for wear.

Wide Range. 37" cutting point to frame and 18" under guide.

Well Protected. Swinging wire cage covers upper wheel. Metal doors over lower, giving easy accessibility. Lower wheel equipped with refuse guards. Automatic spring tensioning device prevents breakage of smallest blade.

*Write for our special bulletin
—free for the asking.*

The Tannewitz Works

304 Front Avenue, N. W.
GRAND RAPIDS, MICHIGAN

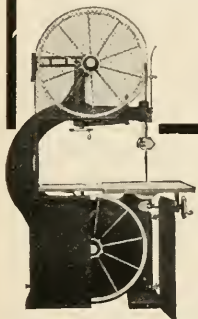

Type "G" Band Saw can be supplied with either motor or belt drive. We can adapt any of our machines to meet your special needs. Write us.

Hard-To-Get Materials

This is the Line you have been looking for

- Unusual Cabinet Hardware
- Chest Trimmings
- Upholstery Supplies
- Cushions
- Mirrors

Catalog to Instructors

Thurston Manual Training Supply Co.

Jobbers and Manufacturers
ANOKA, MINNESOTA

No More Loose Handles

Don't take chances with Hammers with ordinary Wedges when you can now secure the **UNCLE SAM BRAND** Hammers with the new **VAUGHAN'S EXPANSION WEDGE**.

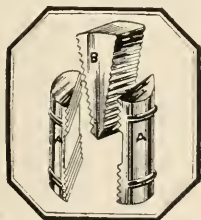

If the handle shows any tendency to become loose simply set the Wedge (B) a notch or two deeper between the pins (A) and a tight handle is assured.

UNCLE SAM HAMMERS are the only Hammers that have been approved by the **UNDERWRITERS' LABORATORIES** and each Hammer has the Underwriters' Label. It took 900 lbs. more pressure to pull the handle through the head with the **VAUGHAN'S EXPANSION WEDGE** than with the Ordinary Wedge. Uncle Sam Hammers are made in all patterns and sizes. *Write for description booklet No. 10 which describes this line in detail.*

VAUGHAN & BUSHNELL MFG. CO.

2114
Carroll
Ave.



Chicago,
U. S. A.



Manual Training Bench, No. 16

which is furnished with one Abernathy Rapid Acting Vise, and with one drawer.

Ask for our new Catalog No. 27

C. CHRISTIANSEN

BENCH MANUFACTURER
2814 W. 26th St. CHICAGO, ILL.



THE WOOD TRIMMER

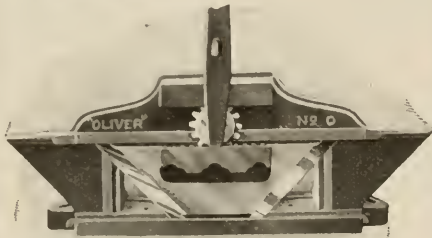

Use the plane and square all day long and you cannot get as perfect a joint as can be made by a few strokes of the Oliver Wood Trimmer.

The Theory and Practice of the Wood Trimmer is explained in our new Bulletin on Trimmers.

Ask for one

Oliver Machinery Co.

Grand Rapids, Mich., U. S. A.

SIMPLIFY GRINDING

With Mummert-Dixon Oilstone Grinders. Five wheels for almost every class of grinding. They accomplish the work quickly and accurately. With this machine your students can experience the pleasure of sharp tools.



The Modern
Edge Tool
Sharpening
Machines.

The
Standard
for all
Industrial
Schools

Five
Leading
Features
Coarse Oilstone
Wheel
Fine Oilstone
Wheel
Emery Wheel
Grinder
Cone
Leather
Wheel

Furnished for motor drive or with counter-shaft
Send for full descriptive bulletin

MUMMERT-DIXON CO., Hanover, Pa.

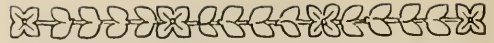

FIELD NOTES--(Continued)

SCHOOL PRODUCTION WORK IN MONTCLAIR

In the manual arts department, Montclair, New Jersey, a number of shop projects have been carried thru on a factory basis and records kept to show whether the work was successful from a purely financial standpoint. One project which was completed consisted of ten woodworking benches.

The cost of these benches is analyzed as follows: 240 ft. lumber at 15c, \$36; boys' labor, \$5.60; ten iron vises, \$32.50; five hours supervision at \$1, \$5; two gross screws, \$1.60; four pounds nails, 30 cents; varnish and oil, \$1.75; five dozen angle irons, \$1.25; total cost, \$84.

According to estimates obtained, these benches would cost \$180 if done commercially.

Other jobs of a similar nature which have been turned out are the making of twenty toy electric motors and ninety baseball bats. The figures of the cost of production of all these show that while the boys have received excellent training under this plan, the work has been done in such a way that it has proved to be commercially profitable.

TEACHING BOYS TO KNIT STOCKINGS

The teaching of knitting of stockings has been introduced as a trade course in the Smith's Agricultural School, Northampton, Massachusetts. Two machines at the cost of \$4,000 each have been installed. The course which has been outlined by Theodore Behringer, the instructor, covers three years and will include every angle of the trade as well as related information regarding raw materials, dyes, etc. The operators will also make a complete study of the very complicated machines used and will be given practice in repair of such machines. Needless to say, Mr. Behringer will not have a wide choice of textbooks to select from for this course. In the absence of such books he has compiled the course from actual experience gained from several years employment in various phases of this industry.

CAREFUL DRIVING CLASS AT
WALTHAM, MASSACHUSETTS

The state of Massachusetts is making an effort to reduce automobile accidents thru the education of car owners and drivers. An evening course of

TOOLS

For Manual Training Shops.
Send your inquiries to and get the especially
low prices quoted by

MONTGOMERY & CO. Inc.,
105 Fulton Street New York City

MAYDOLE HAMMERS

THE WORLD'S STANDARD

Highest Quality Steel Handled Hammers
Guaranteed First-Class in Every Respect

*Booklet of Useful Information
for each student on request.*

The David Maydole Hammer Co.

Norwich, N. Y., U. S. A.

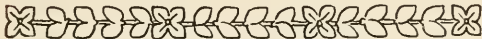

FIELD NOTES—(Continued)

instruction in the mechanism and operation of the automobile is now offered at the Waltham Industrial School by the division of university extension. The class is open to anyone interested and will extend thru ten weeks. Lee L. Smalley, who is the instructor of this class, previously offered a course of similar instruction in Newtonville.

TRADE NOTES

BOY SCOUT TOOL CHESTS

THE development of the Boy Scout Movement has been accompanied by an increased manufacture of several lines of goods in which boys generally are interested. Among these has been a line of tool cabinets manufactured by the Stanley Rule & Level Company. Thirty-one of the sixty-seven badges awarded by the Boy Scouts of America involve the use of tools for doing the things required in passing the tests. This explains in part the growing interest in tools among Boy Scouts. A beautifully illustrated circular will be sent to those writing to the Boy Scout Department, Stanley Rule & Level Company, New Britain, Connecticut.

What a Difference in Manual Training with The RIGHT Knives!

R. MURPHY Stay Sharp Knives for Special Purposes have been the Standard of Enduring Quality and Service for 72 years.

R. MURPHY

◀ *STAY SHARP* ▶

Sloyd and Manual Training, Wood Block, Stencil and Cardboard Knives

are made of the very best English Tool Steel, with Closed Ferrules and Polished Handles, riveted. Tempered by the famous Murphy process.

Here's One of Them →

—a Stencil and Wood Block Knife much in favor with Manual Training Instructors.

Address Manual Training Department

R. MURPHY'S SONS CO.
Ayer, Mass.

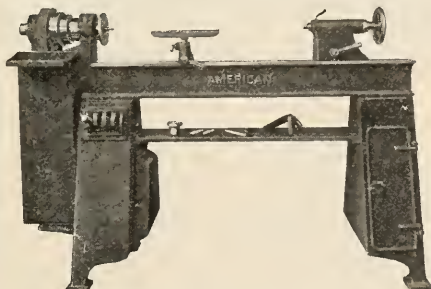

Manual Training Lathe with Motor in Base—24" to 72" Centers

AMERICAN School Equipment

High Quality Machines at Moderate Cost

SAW BENCHES
JOINTERS
PLANERS
BAND SAWS
WOODWORKERS

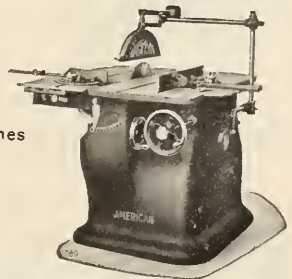

AMERICAN SAW MILL MACHINERY CO.
142 Main St., Hackettstown, N. J.

The Efficiency Grinder
Built Like An Automobile

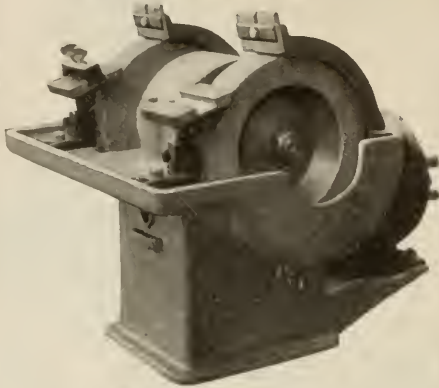

Bronze Bearings throughout. Direct connected motor.

No Power Wiring Required—just plug into any light socket. Ample power—you can't stop it.

Independent Rests. These permit of retaining proper angle between rest and wheel at all times. You cannot grind tools "stubby" as so often happens with a common rest. Each rest is adjusted independently for each wheel, always retains correct angle.

We Furnish Grinding Gauges. Any ten year old boy can grind tools properly on this machine.

Can be furnished in pedestal type. Price reasonable. Quality high. Correspondence is solicited.

EFFICIENCY GRINDER COMPANY
326 W. Washington Av. Madison, Wis.

L-U-M-B-E-R

We Specialize in
Manual Training Lumber

No order is too large or too small to receive our careful attention

John S. Benedict Lumber Co.
419 N. Halsted St. CHICAGO

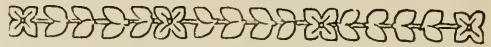

TRADE NOTES—(Continued)

TRY AND MITRE SQUARES WITH LEVEL

Woodworking teachers will be glad to learn that the "Universal" Try and Mitre Square, which was recently brought out by The Lufkin Rule Co., Saginaw, Michigan, is now offered with a level glass.

This square is a popular style with graduated steel blade and movable head. It is made in 9" and 12" lengths.

As now supplied with the level glass it serves also as a plumb, and in many places makes the handling of two tools unnecessary. It is also supplied, if desired, without the level.

MONARCH JUNIOR MOTOR DRIVE LATHE

The Monarch Machine Tool Company of Sidney, Ohio, realize strongly the needs of America for thorough vocational training. They are now, more than ever before, prepared to co-operate with the schools to the end that machines, tools, arrangements and all factors entering into metal working will be the best available. Recently they brought out a new engine lathe called the Monarch Junior Motor Drive Lathe which meets particularly vocational school requirements. A special circular describing this lathe with numerous photographic illustrations

The Real Thing
In Woodworking Machinery
PARKS Four-in-One

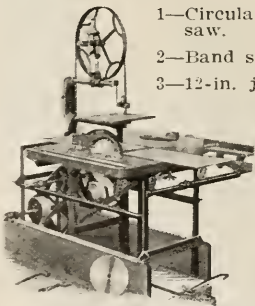

1—Circular rip and cross-cut saw.

2—Band saw.

3—12-in. jointer.

4—Boyer with adjustable sliding table and regulating stop.

Start your students right—

Get a Parks! Price, \$70.00

Send for complete illustrated catalog

The Parks Ball Bearing Machine Co.

1536-46 Knowlton St. Cincinnati, Ohio

Canadian Factory:

200 Notre Dame East, Montreal, Canada

PARKS

"GLUEY"

"The Perfect Paste" now used in many

MANUAL TRAINING DEPTS.
in place of hot glue

Clean—Economical—Sticks

GLUEY spreads readily and is always ready for instant use all ways

Send 10c for full size No. 4 Tube

THE COMMERCIAL PASTE CO.
COLUMBUS, OHIO

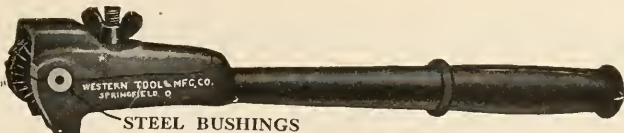

The "Champion" No. 1 Emery Wheel Dresser

Will Outlast a Dozen Cheap Dresser Handles

Handle is made of malleable iron, will not break. Spindle for cutter runs in steel bushings. Easily replaced.

"Tools of Quality" Ask for our Full Catalog

WESTERN TOOL AND MANUFACTURING CO. Springfield, Ohio

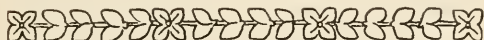

TRADE NOTES—(Continued)

has been published. They have also put out a more complete 12-page circular illustrating their various lathes and showing photographs of numerous installations with a long list of schools where their machines are in daily use. Readers of the *Manual Training Magazine* will find these circulars to contain interesting information regarding machine shop equipment. Copies may be secured by writing the Monarch Machine Tool Company.

USES FOR REDWOOD LUMBER

In looking over the list of "Redwood" booklets issued by the Pacific Lumber Company of Illinois, McCormick Building, Chicago, one is surprised to note the variety of uses for which redwood is adapted. It is used for engineering and industrial products, farm and dairy buildings and equipment, chests, refrigerators, incubators, and furniture frames, in addition to small wood specialties. A booklet describing their 1922 advertising campaign, illustrates many of the uses of redwood. Send for a copy and acquaint yourself with this wood.

Build Your Own PHONOGRAPH

Instructive—arouses pupils' enthusiasm—provides one of the best problems in cabinet making.

Let Your Pupils Build Choraleon Phonographs

We furnish plans, blue prints, motors, tone arms, case material—in fact, everything required. Full instructions. Choraleon's have fine tone. Play any record. Ask for particulars.



CHORALEON PHONOGRAPH CO.
422-7th St., Elkhart, Ind.

Modern Sheet Metal Working Machines

will make your instruction work easier. With Niagara Equipment you awaken that spirit which induces better work.

Niagara lines include every requirement for your course. Get our catalog of Presses, Foot and Power Shears, or Tinner's Tools and Machines.

Niagara Machine and Tool Works

Established 1879

BUFFALO, N. Y., U. S. A.

NIAGARA

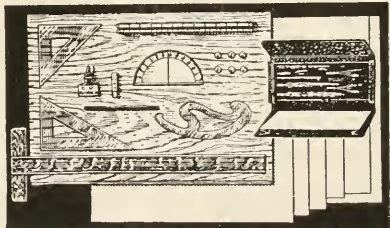

BEST QUALITY OF

DRAWING INSTRUMENTS

Consistent with prices within reach of every student

COMPLETE LINE OF

T. Squares, Triangles, Scales, Drawing Boards, Drawing Papers, Pencils, Thumb Tacks, Etc.

Ask for Illustrations and Prices

THE OLD RELIABLE HOUSE

AMERICAN BLUE PRINT PAPER CO.

445 Plymouth Court, Chicago, Ill.



CLASSIFIED ADVERTISEMENTS



Do you want to sell or want to buy some school shop supplies? Do you want to employ a teacher? Do you want a new position? Advertise your wants in these classified columns. Rate 20c a line, minimum \$1.00.

BASKETRY

BASKETRY MATERIALS. Reeds, raffia, wooden bases, chair cane, Indian ash, splints, cane webbing, wooden beads, braided straw, rush, willow, pine needles, books, tools, dyes. Catalogue and Directions, 15 cents. Louis Stoughton Drake, Inc., 34 Everett St., Allston, Station 34, Boston, Mass.

REED FOUNDATIONS AND SUPPLIES. Veneered tray bottoms, clear pine bottoms, lamp standards and fixtures, galvanized iron containers, finishing materials, etc. Send for catalogue. The Kessel and Nyhus Co., 910 Westminster St., St. Paul, Minn.

COILED BASKET MAKING is completely treated in the teacher's manual by Marten entitled **Inexpensive Basketry**. It outlines a course for grades three to six, accompanied by a series of excellent photographs showing every process. Price 45 cents. The Manual Arts Press, Peoria, Ill.

ELECTRICAL PROJECTS

BUILD "PEPCO" ELECTRIC TOASTERS—A useful and attractive project. Buy the parts from the Practical Electrical Project Co., Highland Park, Illinois.

BLUE PRINTS

FREE CATALOG AND SAMPLE—Blue Prints of Agricultural, Furniture Making, Mechanical Drawing, Wood Turning, Forge Work, Pattern Making and Whittling Problems. Make your work more practical. Work from blue prints. Schenke Blue Print Co., 1034 Carney Blvd., Marinette, Wis.

GRANDFATHER'S CLOCK—Blue prints, finishing material and instructions. Also works, dial, weights and pendulum can be purchased from us at surprisingly low prices. Send for particulars of our attractive offer. Clock Company, 1666 Ruffner St., Philadelphia, Pa.

MANUAL TRAINING LUMBER

YOU CAN SAVE MONEY AND TIME by buying OAK SQUARES and ASH SQUARES in Clear lumber, one to two inches thick and from 15 to 40 inches long. We also specialize in Cedar Chest lumber, Philippine and other Mahoganies. FRANK PAXTON LUMBER CO., KANSAS CITY, KANSAS.

AMERICAN WALNUT LUMBER—We carry a stock of over two million feet of Walnut Lumber, consisting of all grades and thicknesses from 1/2" to 4". Due to this large stock we are always in position to supply dry lumber for Manual Training use. Send us your inquiries. Frank Purcell Walnut Lumber Company, 12th Street & Belt Line, Kansas City, Kansas.

AROMATIC TENN. RED CEDAR BOARDS. Small shipments a specialty. Write us for prices delivered at your railroad station. Earthman Lumber Co., Murfreesboro, Tenn.

MORGAN MANUAL TRAINING MATERIALS—A perfect system of dry kiln enables us to give you lumber thoroughly dry. Carrying in stock large quantities of different woods permits us to fill your orders with the best selections. Write, sending us a list of the materials you desire. We will quote you attractive prices. Morgan Company, Oshkosh, Wisconsin.

LUMBER—Maisey & Dion, 2349 to 2423 South Loomis St., Chicago, Illinois, carry in stock a large and diversified stock of MANUAL TRAINING LUMBER. Fifteen years' experience with schools enables us to fill such orders satisfactorily.

FURNITURE HARDWARE

FURNITURE HARDWARE AND UPHOLSTERY SUPPLIES for Manual Training. Drawer pulls, costumer hooks, wood knobs, box fittings, tea wagon wheels, electric cluster posts, cedar chest locks, handles, hinges, etc., mirrors, wood dowels, Seng bed equipment, Stanley Tools. Send for Catalog, Ohio Vocational Supply Co., Wapakoneta, O.

ELEMENTARY HANDWORK

TAWIDO LOOMS with four treadles weave from 12" to 20" widths. Desk and Table Looms, 6" to 12". Tapestry loom 34". Shuttles, Yarnwinders, Warp Frames. Instruction in pattern weaving and tapestries. Elna M. De Neergaard, Tawido Looms Studio, 23 Union Square West, New York, N. Y.

EVERYTHING FOR ELEMENTARY HANDWORK—Also for basketry, weaving, bookbinding and chair caning, Mounting boards, Waldcraft dyes, crayons, burlap, scissors, punch and eye sets. Thomas Charles Co., 2249 Calumet Ave., Chicago.

UPHOLSTERY MATERIALS

CUSHIONS—You know your cushions will be made right when furnished by the Grand Rapids Cushion Company. Write for estimates on cushions and all kinds of upholstery supplies. Grand Rapids Cushion Company, Grand Rapids, Michigan.

CUSHIONS, APRONS, UPHOLSTERING SUPPLIES. If you make your own cushions we can supply the materials at reasonable prices. If you want complete cushions, we know how to make them, and our prices will interest you. Illinois Valley Awning & Tent Co., 102 S. Washington St., Peoria, Ill.

SCHOOL SHOP SUPPLIES

SODERING SUPPLIES, including the famous Allen Non-Acid Sodering Fluxes—in stick, paste, salts and liquid form; handy soder sets, sodering tools, aluminum soder and flux. As pioneers in the development of fluxes that far surpass muriatic acid, in every way, and as the original exponents of non-acid fluxes, the House of Allen has for 25 years maintained a position of leadership in the Arts and Crafts concerned with sodering. Send for our Bulletins L. B. Allen Co. Inc., 4584 N. Lincoln St., Chicago, Ill.

ANNOUNCEMENTS

IT IS NOW POSSIBLE for you to secure the parts necessary to build electric toasters. Write today for circular and price list to the Practical Electrical Projects Co., Highland Park, Illinois.

SEMI-PRECIOUS STONES

SEMI-PRECIOUS STONES. Large stock of Lapis, Moss Agates, Jaspers, Turquoise, Quartz Amethyst, California Jade, Amazonite, Chalcedony, Abalone Pearl Opals, Abalone Blister Pearls, and many other stones faceted and cabochon always on hand. Special sizes cut to order. Unsurpassed facilities. Memorandum assortments for selection gladly sent to instructors who write us on their letterhead. The Gift Crafters, School Arts Department, Tujunga, California.

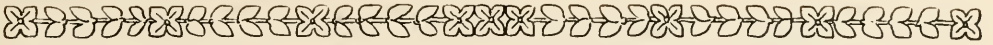

BOOK NOTES

THE order in which new books are expected to appear from The Manual Arts Press is as follows: (1) *Working Drawings of Colonial Furniture* by Frederick J. Bryant. (2) *Sheet-Metal Pattern Drafting and Shop Problems* by James S. Daugherty. (3) *Sewing Machines* by Rosamond C. Cook.

The first of these was described in this column last month, as was also *School Shop Installation and Maintenance* by L. S. Greene which has already been published and is now being distributed. This book is going to answer dozens of questions for teachers who are confronted with the problem of installing new equipment. "If I could have had such a book when I began teaching shopwork I would have avoided some of the mistakes I made in those early days." This is what the older teachers are saying about this book. It is the first time that the knowledge of the engineer and the millwright have been combined with that of the teacher and together put in book form for teachers of limited training and experience.

THERE is every reason to believe that the new book by Mr. Daugherty will be regarded as the standard book on sheet-metal work for vocational schools and other schools that are interested in giving serious attention to the best practice in sheet-metal work. The book is a comprehensive text and problem book, attractively illustrated with photographs and containing excellent working plates. The subject-matter and method of presentation are the outcome of many years of teaching and practical experience in various branches of the sheet-metal industry. The book presents the problems in the proper sequence for successful instruction in pattern drafting. The descriptions are clear and well organized step by step.

In fact, it is hardly necessary to say more than that J. S. Daugherty wrote the book to convince the reader that it is of high grade in everything that an author can contribute to a book, for Mr. Daugherty and his work at Carnegie Institute of Technology are known from one end of the country to the other. His elementary book, which was so well received, was merely the forerunner of what the present volume will be in all that goes to make an excellent working textbook.

It is not yet certain when this book will be ready but probably about the first of May.

Sewing Machines by Miss Rosamond Cook, assistant professor of home economics at the Iowa

State College of Agriculture and Mechanic Arts, is one of those books that has kept growing and growing until now it is far more comprehensive than at first contemplated. While it will be the pioneer book in the field, so far as this country is concerned, it will not have the appearance of a pioneer, but of a well considered, comprehensive, thoro exposition of the sewing machine, and especially suited to school use. Several supervisors who have seen the manuscript, or parts of it, have assured the publishers that they want the book for their high school classes as soon as it can be produced.

It is believed now that the book can be out in time for use in summer schools.

THE following review of *Practical Electricity for Beginners* appeared in the March number of *School News*:

"This book is well named. It is both practical and elementary. It was written for use in the junior high school, grammar grade classes, continuation schools, vocational schools and by the boy in the home. It is extremely practical and deals with the facts of electricity and its useful application in a popular, non-technical and interesting manner. It is arranged for class use, but is well adapted to inspire and instruct in the operation and repair of electrical appliances in the home or wherever found."

JUST after the March number of this Magazine appeared we were asked to recommend a book on wood-carving. We called attention to the English book reviewed in that number, but added that if the information was wanted for use in a school where carving was to be used as a means of decorating woodworking projects, and rather elementary in character, one could not do better than consult Chapter VI in *Woodwork for Secondary Schools* by Griffith. This chapter is entitled "Inlaying and Wood-carving" and contains many practical suggestions for beginners.

A PROMINENT state supervisor of industrial education writes as follows concerning *School Shop Installation and Maintenance* by Greene:

"I feel that this book will render a distinct service to industrial arts teachers in the field. Mr. Greene is to be congratulated upon the very practicable way in which he has organized the material. I am very sure that it will be a valuable reference book for all teachers."

The Steen KEYLESS COMBINATION LOCK



Used and Recommended by

*United States Government
University of Illinois, Urbana
University of Dallas, Texas
Lake County High School, Waukegan
Oberlin College, Ohio
Central High School, Grand Rapids
Michigan Agricultural College
Westminster College*

- For
- Manual Schools
 - High Schools
 - Colleges
 - Gymnasiums

No locker is complete without a STEEN KEYLESS COMBINATION LOCK; the most satisfactory—safe—and durable keyless lock on the market.

With Steen equipped lockers you never have to worry about replacing lost keys or calling the janitor to break open lockers and tool cabinets. ALL possibility of theft is eliminated for the STEEN cannot be opened until the right combination has been completed.

Made in a variety of styles and sizes—there is a STEEN for every locker. We will be glad to send a sample lock for your inspection. Write for the B2 STEEN—and do it NOW.

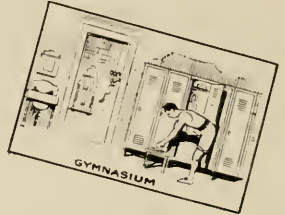
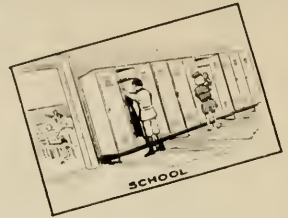

TRIPLE METALS CORPORATION

Dept. B4

WAUKEGAN, ILLINOIS



High Grade Drawing Instruments

Largest Assortments
Highest Quality
Limited Quantity
100% Value: Order Now!

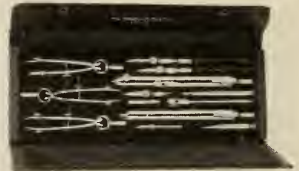

Set No. 60

ASK FOR CATALOGUE

This Special Set Your Opportunity, \$9.75 Postpaid

Complete Drawing Outfits from \$5.00 Up

THE FREDERICK POST CO.

MANUFACTURERS

319 So. Wabash Ave.

CHICAGO

3635 No. Hamlin Ave.

MANUAL TRAINING MAGAZINE

EDITORS CHARLES A. BENNETT, Peoria, Illinois.

WILLIAM T. BAUDEN, Assistant to Commissioner of Education Washington, D. C.

ASSOCIATE ARTHUR D. DEAN, Professor of Vocational Education, Teachers College, New York City.

EDITORS: FRANK M. LEAVITT, Associate Superintendent Public Schools, Pittsburgh, Pa.
WILLIAM E. ROBERTS, Supervisor of Manual Training, Public Schools, Cleveland, Ohio.

Business Manager: L. L. SIMPSON.

Published monthly by The Manual Arts Press, 237 N. Monroe St., Peoria, Illinois.

Subscription Price, \$1.50; Canada, \$1.80; Foreign, \$2.00. Single Copies, 25 cents; Foreign, 30 cents.

Subscriptions, remittances and manuscripts should be sent to THE MANUAL ARTS PRESS, Peoria, Illinois.

CONTENTS

ECONOMIC CIVICS.....	Frank M. Leavitt	373
THE PRESENT STATUS OF INDUSTRIAL ARTS EDUCATION IN OUR ELEMENTARY SCHOOLS.....	A. H. Edgerton	377
TEACHING BATTERY CONNECTIONS (Illustrated).....	W. F. Perry	385
THE EASTERN ARTS CONVENTION.....	Charles A. Bennett	386
EDITORIAL REVIEW FOR THE MONTH.....		390
The Project Problem—Progress in Teaching Shopwork—Vocational Teacher Training in California—A New Supervisor in Minnesota—Manual Training Shop Not a Play Room.		
A POINT OF VIEW.....	Arthur Dean	394
Present Status of Part-time Schools.		
WASHINGTON CORRESPONDENCE.....	William T. Bawden	397
Federal Board for Vocational Education—Financial Support of Vocational Education Largely a State and Local Matter—Foreman Training in Virginia.		
IN FOREIGN COUNTRIES.....		398
Viewpoints Concerning Secondary and Higher Education—Exhibit of Continuation School Work in London—Use of Colored Plaster Casts.		
PROJECTS, PROBLEMS AND NOTES.....		400
A Pantagraph—Chair Lamp—Dancing See-Saw.		
CURRENT PUBLICATIONS.....		405
FIELD NOTES.....		VI
Night Schools at Casper, Wyoming—Minnesota News—California Field Notes— Southeastern Items—Around New York—From the Southwest—Industrial Education in Hawaiian Islands—Homework Among Chicago Invalids—New England Items— New Jersey Vocational and Arts Association—Psychological Corporation Organized —Eastern Arts Going to Providence—Shortage of Teachers in Chicago—Emphasizing Practical Side of Art—Items of Progress.		
TRADE NOTES.....		XXXVI
BOOK NOTES.....		XLV

This Magazine is kept for sale at McClurg's in Chicago, and Brentano's in New York.

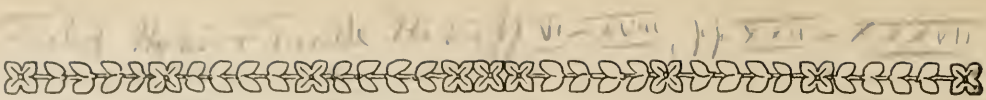

FIELD NOTES

NIGHT SCHOOLS AT CASPER, WYOMING

VOCATIONAL night school classes being conducted at Casper, Wyoming under the general or state supervision of J. R. Coxen, state director of vocational education and the local supervision of J. W. Hoyer, director of industrial arts, have outstripped all competition in enrollment, and the night school at Casper is, therefore, the largest vocational night school in the state. This is a record of which the school authorities in Casper are very proud owing to the fact that this is only the second year that a night school has been conducted there.

GROWTH OF CASPER SCHOOLS

Until last year it was not deemed advisable or even possible to conduct vocational night school classes in Casper on account of the peculiar local conditions. Its rapid growth has made it extremely hard to conduct the schools on account of the changing population. Casper is known as one of the greatest oil towns in the entire U. S. It is extremely doubtful if there is another school district in the U. S., or the world for that matter, which can point to a record of growth in the past ten years equalling School District No. 2, which is the Casper City District. In 1911 with a population of 2800, a school enrollment of 472 and 15 teachers employed, there were two banks in the city with resources of \$1,100,000 and the assessed valuation of the district was \$2,369,394. In the fall of 1921 the population had grown to an estimated population of 25,000, with a school enrollment of 3,796 and over 150 teachers employed; the banking houses meanwhile having increased to seven with resources of over \$11,000,000, and the assessed valuation of the district having shown the marvelous increase to \$52,817,420. This phenomenal growth is very largely due to the discovery of oil in the nearby vicinity and the building of two very large refineries in the city of Casper, with plans going forward for another refinery to be built the coming spring.

NIGHT SCHOOLS IN SECOND YEAR

Last year under the leadership of A. A. Slade, the new city superintendent of schools, night school classes were organized in a few subjects for the first time, in spite of predictions that the people were not interested in night school work and that they would not attend. There was a very generous response from the men employed in the refineries and the work given was very successful and much

appreciated. With the day school enrollment jumping about 50% in the grade schools and 100% in the high school and the necessity of providing more buildings to take care of the large increase in the number of students, Mr. Slade found it impossible to look after the night school this year. In the last two years six new buildings valued at \$650,000, including a new \$250,000 vocational high school building, have been erected and even these new buildings do not adequately take care of the students. In employing the director of industrial arts for the city school system this year, one of the requirements of applicants was the ability to organize and supervise this vocational night school work in addition to the industrial work of the day school. From a large number of applicants, J. W. Hoyer, for the past three years director of the industrial arts department of the Northern Normal and Industrial School at Aberdeen, S. D., was elected to the position and has been in charge of the night school work this year. Under his supervision the vocational night school classes were organized and are being conducted under the auspices of District School Board No. 2 of Casper. These classes met with an immediate response and widespread enthusiasm and appreciation, and the co-operation which is being received from various sources indicate that this night school training will be a great success this year. In this, the second year that classes in vocational training are being offered by Casper schools, an increase of almost 100% over the enrollment of a year ago has been reached.

MANY CLASSES ORGANIZED

As stated above, Casper being an "oil town," the classes which were organized had to meet much more peculiar and special conditions than are found in the average city of 25,000. Many special classes are offered here which will be found only in an oil region. Even the work in such classes as blue-print reading and mathematics have special conditions and problems to meet in this section. Another strange condition is the very small number of foreigners in the city. Recent reports show about 1% of the population to be foreigners, while the percentage of illiteracy is about 2-10 of 1% for the city, consequently the English for foreigners and Americanization classes conducted under the same supervision as the vocational classes are rather small, but enthusiastically attended.

Vocational classes are conducted in three centers as follows: three classes in blue-print reading and



The Precision Tool of a Thousand Uses

THE Common Sense Way--take the machine to the work.



PERFECTLY meets the need in Furniture Factories, Manual Training Establishments, Pattern Shops, and the like for a high grade tool which will perform minor operations with speed and exactness.

What It Is. A motor of ample power is mounted upon a tilting frame and belted to the saw. Motor and saw swivel 45 degrees in either direction, permitting both right angled and oblique cuts to be made with ease.

Thoroughly Well Built. While the TANNEWITZ is by no means a toy, it yet requires less power and less floor space than any other. The safest saw on the market. Designed for accurate workmanship, with more exclusive precision features than any other.

A Tool of Universal Usefulness. The TANNEWITZ Portable plugs into the nearest electric light socket, and is therefore, easily used anywhere.

Fully Guaranteed. We are responsible manufacturers of large and finely adjusted saw benches, and fully guarantee the materials and workmanship of the TANNEWITZ Portable.

Write for our special bulletin or better still, wire us for your trial machine.

THE TANNEWITZ WORKS

304 Front Ave., N. W Grand Rapids, Mich., U. S. A.

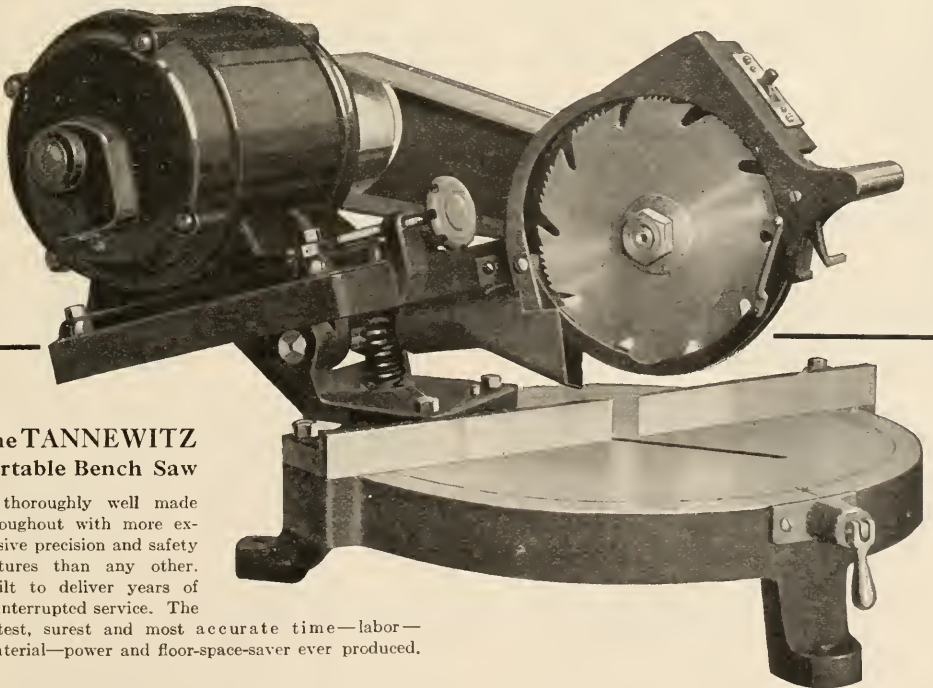

The TANNEWITZ Portable Bench Saw

Is thoroughly well made throughout with more exclusive precision and safety features than any other. Built to deliver years of uninterrupted service. The fastest, surest and most accurate time—labor—material—power and floor-space-saver ever produced.



FIELD NOTES—(Continued)

shop sketching, two in use of the steel square, one in petroleum geology, one in petroleum chemistry, one in lay-out work for boilermakers, one in practical electricity, one in elementary mathematics, two in advanced shop mathematics, one in fundamentals of steam engineering, one in sewing, two in millinery, one in English for foreigners, and one in Americanization, making a total of eighteen classes with an enrollment of over 350. The problem of finding teachers for some of these classes was far from being a simple one, but thru the co-operation of the officers and executives of the Standard Oil Co. and the Midwest Refining Co. employees of those companies were secured for the classes in petroleum geology, petroleum chemistry, layout work for boilermakers, electricity, steam engineering, blueprint reading, one of the advanced mathematics classes, and one of the classes in use of the steel square; while another section of the two last named is taught by one of the contractors and builders of the city. The elementary mathematics and the other advanced mathematics are taught by vocational high-school teachers. One of the millinery classes is taught by one of the domestic arts teachers while the other is under the supervision of a milliner. The sewing class is taught by a former domestic science teacher. The Americanization work is in charge of one of the successful attorneys of the city while the English for foreigners is being cared for by one of the special teachers of the city schools. All of these classes are organized under and meet the requirements of the Smith-Hughes Law with the exception of the English for foreigners and the Americanization work. These two classes are organized under the State Americanization law and are also under the supervision of State Director J. R. Coxen.

Lack of funds and shops prohibited the organization of more classes this year, but it is hoped to have a new high-school building next year (in spite of the fact that the new \$250,000 Vocational High School is being used for the first time this year), which will provide additional shops and laboratories, thus making it possible to offer other lines of work. If present plans can be carried out the Smith-Hughes vocational night school classes in Casper will show another large increase next year.

MINNESOTA NEWS

THE Federal Board for Vocational Education will hold another summer conference at Dunwoody Institute, Minneapolis. It will be in the nature of the one which was so successfully conducted last year. Three or more representatives

are eligible from each state. Charles R. Allen of the Federal Board will have charge of the conference. The first unit, from June 15 to July 15, will be devoted to home economics. The second unit, running from July 15 to August 15, will be devoted to trade and industrial education.

LARGE ATTENDANCE AT NORMAL SCHOOL

The spring term of the Moorhead State Teachers' College finds 108 students pursuing courses in the manual arts department. This includes, besides those enrolled for manual arts teacher training, some who are taking general teacher-training work; and is the greatest number in the history of the school.

MC GARVEY ASSUMES NEW DUTIES

Brief announcement was made last month of the resignation of G. A. McGarvey as supervisor of trade and industrial education of the State Department of Education. Mr. McGarvey will assume his new duties in Washington, April 1. He will be the agent for the Federal Board for sixteen New England and Middle Atlantic states, with headquarters in Washington, D. C. In addition to his duties of inspection, etc., he will be largely engaged in conducting investigations, trade surveys, and the like, in the north-eastern section of the country. His appointment comes as a recognition of his ability in this latter capacity, as shown by some of his work in Minnesota. Mr. McGarvey's many friends in this state, while regretting his departure, will congratulate him on his new appointment.

THE MINNESOTA ART FORUM

The first meeting of the Minnesota Art Forum was held on March 12th in Minneapolis. This organization was formed at the annual meeting of the Minnesota Educational Association in Oct. 1921. At that time the name, Minnesota Art Teachers' Association, was proposed for this new organization, but this name suggested a limitation of membership to those engaged in teaching; whereas the name was to suggest that all makers of artistic products are art teachers as well as those engaged in teaching school.

This new name being more inclusive admits to membership all who are engaged in the advancement of art. Emphasis was placed on appreciation of art in daily life; that the introduction of art to rural communities should not be remote as European art treasures—but an awakening should be made to the beauty abounding in their own environment. When this results in the river front becoming the "front yard," and not the "back yard" or dumping ground;—when bill boards on country roads no

LITTLE GIANT MANUAL TRAINING DEPARTMENT Special Equipment

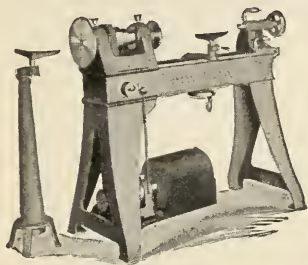

LITTLE GIANT WOOD LATHES

Individual Motor Driven, or Belt Driven from above or beneath.

Furnished with either Bench or Floor Legs. Wide choice of optional tools and equipment. Four speeds.

Many new, exclusive and practical features. All bearings are Hyatt High Duty Roller Bearings which greatly reduce power required. Ball Thrust bearings at all points of end thrust.

Sold on 30 days trial, and **GUARANTEED FOREVER** against defective material and workmanship.

LITTLE GIANT METAL LATHES

Individual Motor Driven, or Belt Driven from above or beneath.

Furnished with either Bench or Floor Legs. Wide choice of optional equipment. Three speeds.

Many new, exclusive and practical features are also found on our metal lathes. They are fitted to receive attachments for grinding, milling, gear cutting, etc., all of which we will furnish at a small fraction of the cost of a separate machine for such work.

Sold on 30 days trial and **GUARANTEED FOREVER** against defective material and workmanship.

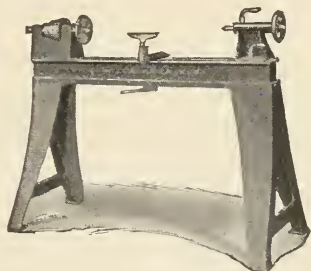

LITTLE GIANT POWER HAMMERS

Individual Motor Driven, or Belt Driven from above. Hundreds of different form-forging dies for instruction purposes.

Standard equipment with leading Technical and Manual Training Institutions.

Sold on 30 days trial, and **GUARANTEED FOREVER** against defective material and workmanship.



DO NOT OVERLOOK

Metal Working Equipment in your school. Wood can never be made anything else, while metal working and alloying are in their infancy.

The Industrial Leaders of the world, to a very large extent, began as metal workers.

Wood working is artistic, and trains mind, eye and hand to deftness. Metal working does all this, and more. It is also practical, and the graduate invariably finds a position waiting for him, while the wood working department graduate usually takes up something else and his instruction is forgotten.

Little Giant Equipment for Technical and Manual Training Schools consists of a full line of all metal and wood working machinery including accessories and tools for same.

On Motor Driven Equipment, information will be required as to Current, Voltage, Phase and Cycles of Motor.

Our business commenced in January, 1876, more than 45 years ago, and our Little Giant Products are used throughout the world. We are anxious to serve you for we can do it well.

Quotations and descriptive literature can be secured from any jobber, or direct from us.



LITTLE GIANT COMPANY

220 ROCK ST.

MANKATO, MINN., U. S. A.



FIELD NOTES—(Continued)

longer destroy the beauty of the natural landscape, —the community will have an appreciation of its own environment and will then be receptive for an appreciation of art beyond its immediate surroundings. The art of the museums is negative in effect;—the masses get their own art out of it. They should be taught the appreciation of great art after awakening to the beauty surrounding their own community. Then will they know that in any way they express beauty they are for this generation carrying on the work of the great art producers of the past. This it is believed to be a great responsibility. The object of this society is therefore the promotion of the Art Ideals thru organized effort of the community.

—JOHN F. FRIESE.

CALIFORNIA FIELD NOTES

FOR over a year now the California State Board of Education thru its Commissioner of Vocational Education, Dr. Edwin R. Snyder, and his assistant, the State Supervisor of Trade and Industrial Education, J. C. Beswick, has exhibited a marked interest in establishing such new vocational courses as the needs of the state demand. To this end, Mr. Beswick, in his travels over the state, has been interviewing the heads of the more important industries in this state, and upon his recommendation, Dr. Snyder has made a personal study of the industries which because of their needs and importance warranted first consideration.

The investigations brought to light the fact that there were two outstanding fields which called for immediate and urgent attention; namely, the work of dental assistant and that of watch repairing. Studies in this state have revealed the fact that there is such a dearth of skilled workers in these fields as to make the situation serious.

WATCH REPAIRING TO BE INTRODUCED

IN THE FIELD of watch repairing the dearth of skilled workmen is exceptionally acute. One of the leading jewelry merchants in the state reported at the time of the investigation that he had been obliged for some time back to refuse to accept for repair all watches not purchased at his store. He predicted that unless some way was found to bring into the field more workers and better training for apprentices, a serious crisis would soon be before us.

As the watch-maker employers are members of the Gold & Silversmiths' Association, that association with headquarters at San Francisco, took it upon itself to request Dr. Snyder and Mr. Beswick

to attend a special committee meeting, at which the matter of public school participation in the training of watch-makers might be discussed. The outcome of the discussions was a decision by Dr. Snyder to guarantee that the state office would help to forward a plan of training and an agreement on the part of the Gold & Silversmiths' Association committee to assist the state office to formulate a recommended course of training. The committee also offered to help any community that signified its desire to establish a course of training for watch-makers, by seeing to it that the necessary equipment is secured at a minimum cost.

COURSE FOR DENTAL ASSISTANTS

IN THE DENTAL field the progress of the work has come to even a more advanced stage. The State Board of Education is now prepared to assist any school in establishing the desired courses for dental assistants. In bringing the work to this stage of advancement, the California Dental Association has been of very material help, and on the basis of its suggestions, Mr. Beswick is making the following recommendations: (a) Persons who may be admitted to the course should have had at least two years of high school work or the equivalent, (b) Or, graduates of grammar school, who can speak English well and are of a relatively high grade of culture, who have had not less than four years of practical experience may be admitted and their experience accepted in lieu of two years high school training. Experience in a dental office, it is recommended, should be given special recognition.

The work of the proposed course may be divided into two major parts—applied work and supplementary work. The applied work, as may be expected, is carried on in dental laboratory and dental office work, and the supplementary work includes general science, physiology and hygiene, and book-keeping and typing. During the second year of the course it is recommended that the student spend a considerable amount of time each week in the practical dental office and laboratory, under supervision, in order that experience may be obtained under practical conditions. The supplementary work of the second year includes such science as is of special value to the dentist, particularly in chemistry and bacteriology. The office practice includes such matters as decorum, management, and business procedure.

It is the hope of the state office that it will not be long before students will elect to enter dental-assistant work upon entrance into the high school

Get Your Copy of this Book

It's the best book ever published on Artistic Wood Finishing and should be in the hands of every Wood Finishing Instructor. It is full of valuable information on finishing all wood—soft and hard. Considerable space is devoted exclusively to the finishing of manual training models. It's the work of experts—illustrated in color.

How To Get It FREE

Write us (mentioning the name of the firm from whom you buy paints, varnishes, etc.,) and we will gladly send you our book "The Proper Treatment for Floors, Woodwork and Furniture" free and postpaid.

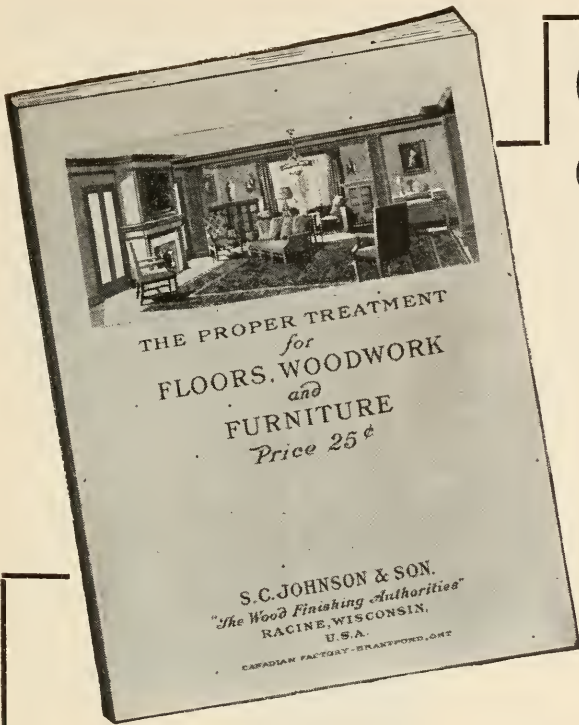

JOHNSON'S ARTISTIC WOOD FINISHES

Johnson's Artistic Wood Finishes are particularly adapted for manual training work as they may be applied by the youngest and most inexperienced pupils with good results. Johnson's Artistic Wood Finishes are standard for manual training—they are being used all over the United States and Canada for this purpose.

Our line of Artistic Wood Finishes is complete—it includes:

Johnson's Prepared Wax

Johnson's Wood Dye

Johnson's Crack Filler

Johnson's Paste Wood Filler

Johnson's Perfectone Undercoat

Johnson's Perfectone Enamel

Johnson's Electric Solvo

Johnson's Varnish

You will find this entire line described in our book. Any time specific information is desired, or whenever you want specially finished wood panels, do not hesitate to write us. We solicit correspondence with Manual Training Instructors.

Mail attached coupon for this authoritative book on Wood Finishing.

S. C. JOHNSON & SON, Dept. MT5, Racine, Wis.

"The Wood Finishing Authorities"

Canadian Factory, Brantford

S. C. JOHNSON & SON

RACINE, WIS., DEPT. MT5.

(Canadian Factory, Brantford)

Please send me free and postpaid your authoritative book on Artistic Wood Finishes for use in Manual Training Work.

The best dealer in paints here is _____

My Name _____

My Address _____

City and State _____



FIELD NOTES—(Continued)

or at least at the beginning of the second year. For them it is recommended that they should take courses in general mathematics, drawing and design, and other handcraft work. The outlined course, as proposed by Mr. Beswick, includes a study of the function of the teeth from the physiological, mechanical, masticatory, and the aesthetic standpoint. It also includes a study of the descriptive anatomy of the various teeth, the arrangement of teeth in the dental arch, and the tissues and gums. Much of this work, it is intended, should be accompanied by drawings, carving, and modeling from specimens of extracted teeth. The dental radiography includes studies in electricity with reference to the various electrical units, as ohms, amperes, volts, watts, the spark gap and tubes, and electro-magnetism, including a study of temporary and permanent magnetism, induction currents, coils, and transformers, and interrupters. This course is designed to include also a study of X-ray tubes, the nature of X-ray and how it is

produced, the installation of X-ray equipment and the making of radiographs. This phase of the work embraces a study of photographic plates and films, the nature of photographic emulsions, and the technique for inter-oral films, which includes the handling of patients and the placing of films. In conjunction with this branch of the work, a study is to be made of the handling of plates with regard to loading, placing, and exposing. Following this, a study is to be made of the dark room, its equipment, materials, and process. The course in dental prosthesis embraces the making of casts and models in various materials, plaster of paris, alabaster stone, etc., the properties of materials both physical and chemical employed when working directly on the patient. This branch of the course embraces also a study of metal dies, both large and small, amalgam dies or models, and wax patterns. It includes also the construction of clasps, the making of plate repair, and the building of crowns.

—CHAS. L. JACOBS.



SHEET-METAL WORK DONE BY STUDENTS OF SOLDIER-REHABILITATION CLASSES IN THE BOSTON TRADE SCHOOL.

IN SCHOOL OR SHOP—this Outfit will Start You Right



In learning to work metals within close limits, here's two good rules for every beginner:

Be sure of your *tools*.

Be sure of your *methods*.

Starrett Tools and the Starrett Book for Machinists' Apprentices will start you out right on both counts.

Copy of Starrett Catalog No. 77 describing and illustrating 2100 fine precision tools—also copy of special Supplement to the Catalog showing latest additions to the Starrett line—sent free on request.

THE L. S. STARRETT CO.

*The World's Greatest Toolmakers
Manufacturers of Hack Saws Unexcelled*
ATHOL, MASS.



Thousands of Young Men Have Bought this Book 180 pages of easily understood information and special tables invaluable to machinists' apprentices and students. Copy sent postpaid to any address, 75 cents.

Starrett Tool Set, No. 901

Especially designed for use by students and apprentices. A thoroughly practical set of fine tools recommended by instructors and master machinists. See the Starrett Catalog No. 77 for details.

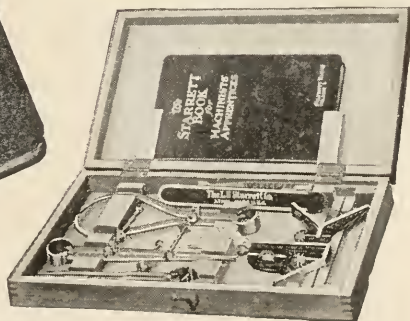

42-307



Use Starrett Tools



FIELD NOTES—(Continued)

SOUTHEASTERN ITEMS

VOCATIONAL WORK IN GEORGIA

THE VOCATIONAL work being done in Georgia is not only state wide, but it is also trade wide in the many lines of instruction in different industries.

The Auburn Avenue School in Atlanta has an enrollment of 400 men, women, boys, and girls. These people are part-time students and are getting training in salesmanship, bookkeeping, filing, business English, spelling, arithmetic, and other specific courses. Each group spends two hours daily under training.

At Porterdale, the Bibbs Manufacturing community, part-time work is conducted in connection with the textile industry. Courses in operations, processes, and calculations in connection with the cotton-mill industry are given in addition to studies in civil government. Manufacturers say that such part-time work is the salvation of the cotton mill. The men need to realize that there is a chance for promotion, and the women need the work for the satisfaction it will give them. At the present time there is not much chance for a woman to be promoted in a cotton mill; but if she is given vocational training, she will work more intelligently and with more satisfaction.

The old Richmond Academy at Augusta opened its doors for evening trade work after a darkness lasting 137 years. O. C. Skinner, who had charge of the evening trade work, but resigned to enter business, has been succeeded by J. E. Eubanks. Augusta has 125 men enrolled in the different night school courses such as auto-mechanics, car inspection, locomotive repairing, boiler work, and electricity. A group of 65 overseers, secondhands, and section men of the four cotton mills meet in a weekly conference similar to a foreman training group.

Savannah has 100 men enrolled in its evening classes. Courses for electricians and boiler-makers are offered in addition to the regular trade classes. C. J. DeMars is local director of the evening trade classes.

The work at the Negro Industrial School prepares the negro boy for productive work. President Wiley expresses it in the following manner. "We don't need German, French, Latin, and higher mathematics out here, we can't use them. A man can learn to be a good tailor, shoemaker, chauffeur, carpenter, and many other things useful. A woman can be a good laundress, seamstress, cook, nurse and other things that our race needs, and can use in the upbuilding of our race."

Other trade classes are being conducted in Columbus, Athens, Lagrange, Macon, Gainsville, Rome, Manchester, New Holland, Reynolds, Rossville, Trion, and Bibbs City.

The total enrollment of all students in the Smith-Hughes classes for last year was 1,711.

—FOREST T. SELBY.

AROUND NEW YORK

WORK of the students of the Manhattan Evening Trade School was displayed on the evening of March 8, and visitors also were given a view of the students at work in the classrooms. The great power machine room on the eighth floor was in operation. There all materials are cut out. Embroidery and all straw operating is also carried on here. The hundred workers admitted have had experience in operating electric-power sewing machines. On the seventh floor most of the drafting and designing is done. No patterns are used, but different kinds of materials are cut and draped on figures and models. Those who have had some experience in dressmaking are enrolled in this course.

On the sixth floor are various novelty classes, including the making of candle and lamp shades in silks, brocades, etc.; also the making of sewed novelties, and all styles of novelty boxes; and French novelties in cretonne, chintz, silks and tapestries. The artificial flower and feather making is an attractive branch which admits beginners.

There are also classes in manicuring, shampooing, scalp treatment, and round curling. The pupils practice on one another. In the department of interior decorating, women in the trade, who wish to have advanced work in color theory, knowledge of fabrics, period furnishing, and various types of decoration are under instruction. The millinery department presented a number of lovely creations turned out by clever pupils.

The drafting and draping for dressmakers is on the fourth floor, and the advanced dressmaking class is on the third floor.

There are in the neighborhood of 1,500 pupils at present in the evening trade school. Free two-hour lessons are given each class twice a week. Muslin and paper are furnished by the school board, but materials are purchased by students either from the school stock or outside stores. When finished, the model belongs to them.

Other trades taught in the school are hand embroidery, batik and dyeing, straw-hat making, salesmanship, textiles, civics, and labor laws, shop English, shop accounting, gymnastics and hygiene,

GRIFFIN COPING SAW BLADES

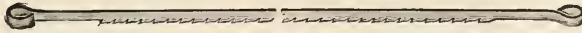

6 inch—Loop Ends

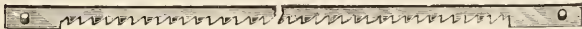

6 1/2 inch—Pin Ends
Also furnished in 6 inch



Manual Training Instructors

endorse the Griffin Coping Saw Blades, because they have successfully stood the most severe tests. The teeth have a distinct "set" for easy clearance. They are carefully hardened and have an

Unusually Good Temper

ALWAYS SPECIFY "GRIFFIN" Coping Saw Blades. Your Dealer will supply you—if not write us.
SALES DEPARTMENT

JOHN H. GRAHAM & CO., 113 Chambers St., NEW YORK
Pacific Coast Office: 268 Market St., San Francisco, Calif.

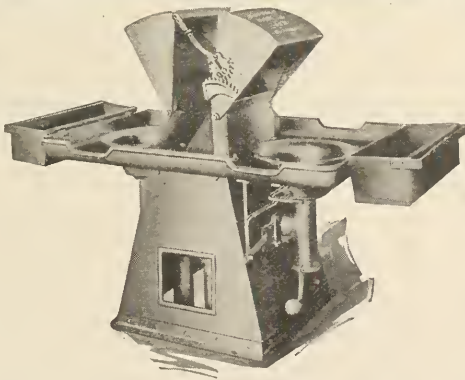

Buffalo

BUFFALO DOWN DRAFT FORGES

The down draft feature places the Buffalo forges in a class by themselves. Draft hoods are made of cast iron which does away with the possibility of corrosion. The use of down draft forges makes possible a gas and smoke free work shop.

Our engineering department is at your service to aid in laying out and recommending the best forge shop equipment to meet your needs. This service is yours for the asking.

Buffalo Forge Company

Buffalo, N. Y.

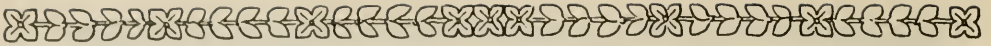

FIELD NOTES—(Continued)

cooking and lunch-room work, and teacher training for industrial schools. On entering each pupil picks out her own line of study. All courses are divided into two units (ten nights in each unit). Five units give a certificate, while the completion of ten units in either one subject or a combination of two subjects, is required for a diploma. No one is admitted who does not meet the requirements of the course for which application is made.

RADIOPHONE DEMONSTRATION HELD

ONE OF THE FIRST demonstrations in wireless telephone operation given in any public school took place at the Brooklyn Continuation School, March 10. The demonstration was introduced by a talk on the theory of the wireless telephone. The electric wiring and installation classes studied the instrument and noted how it was constructed, installed and dismantled. The machine was of a high power type, and was used with an amplifier. Among the stations heard were the United States Navy Yard calling a ship at sea by code, the Bush Terminal signaling, and W. J. Z. Newark music.

GOOD TASTE IN DRESS

GIRLS FROM the local high schools have contributed substantially to the 500 or 600 designs displayed at the exhibition of good taste in dress of young girls, being held at the Art Centre, 65 East Fifty-sixth Street. Among the dresses was one designed by Edith Williams, a seventeen year old student of the Textile High School, and executed by Harry Collins.

There were two exhibits from the Bay Ridge High School. Agnes Steel was the prize winner from this school. Ruth Brandmaker took the Washington Irving High School prize by Hickson for girl about eighteen.

Private and public high schools from different parts of the country sent specimens from their art classes to compete for the prizes in design. The purpose was to encourage the American girl to develop a style of her own, and not copy a European one, which is not as well suited to her style as the American ideas.

NEW YORK TEXTILE SCHOOL

THE NEW YORK Textile School was established about two years ago. The Manufacturers' Association felt a great need of a practical art school, one whose teachers, besides having the academic qualifications should also have trade experience, in order that the pupils could learn the mechanical construction of the machinery, trade colors, etc. In the class of applied design there are graduates from Columbia University, Cornell, and many other institutions that do not have the necessary

looms and machinery for practical work. Many students are sent to the Textile School by manufacturers to acquire the practical side of designing.

—WM. H. DOOLEY.

FROM THE SOUTHWEST

ON FEBRUARY 13, Thomas H. Quigley, federal agent for industrial education, joined N. S. Hunsdon, State Director of Industrial Education, at Houston to go over the work in Texas.

Monday, the 13th was spent in visiting the day, part-time, and evening classes at Houston. The auto-mechanics class at Harrisburg was also visited on the same day. Monday night, Mr. Hunsdon was taken ill and was forced to go home, while Mr. Quigley made the rest of the trip alone.

Tuesday was spent in company with J. O. Mahoney, Supervisor of vocational and evening-school work, at Dallas. Mr. Quigley was very much pleased with the progress being made in Dallas, especially with the part-time work, which has increased greatly this year.

At Fort Worth the foreman training class conducted by H. M. Robinson at the Northern Texas Traction Company offices was visited. Mr. Quigley was pleased with the work of this class, which is the first foreman training class organization in the state.

From Fort Worth the trip was made to El Paso, where on Thursday afternoon, Friday and Saturday, the work of the El Paso schools was thoroly inspected.

Saturday night and Sunday were spent in traveling from El Paso to San Antonio, where the classes were visited on Monday, the 20, in company with Dr. Jeremiah Rhodes, superintendent of schools, and L. W. Fox, city director of industrial education.

On Tuesday, the 21, Mr. Quigley paid a short visit to the State Department of Education at Austin and had a short conference with Miss Blanton, state superintendent of public instruction.

SMITH-HUGHES EVENING-SCHOOL CLASSES IN HOME ECONOMICS, IN HOUSTON

THE FIRST evening-school classes in Houston for home-makers were started when the night schools were first organized about twelve years ago. Two or three neighborhood groups of women were given courses in practical cookery planned on the basis of cooking and serving meals. They were more or less successful according to the length of time the classes held together. The busy days of the Christmas season, rainy nights, lack of an escort, and other reasons were the excuses given for ir-



SCHOOLS AND COLLEGES



THE STOUT INSTITUTE

Nine Weeks Summer Session

June 26—August 25, 1922

Regular Session Thirty-Six Weeks

September 11, 1922—June 1, 1923

The summer session gives opportunity for students to secure a full semester's credit in shop or laboratory courses by lengthening the periods for this work during the summer session. A half semester's credit can be secured in five hour academic courses.

Summer Session credits apply on work required for the diploma or degree given by The Stout Institute.

The following groups of courses are offered:
Vocational Education—7 professional courses,
 27 shop courses.

Industrial Arts—33 courses.

Household Arts—24 courses.

Science and academic work required for diploma or degree—26 courses.

Athletic Coaching—5 courses.

Catalog giving outlines of courses, schedule of classes for summer session, and full information as to qualifications for entrance, requirements for graduation, and expenses for summer session or academic year, now in press and will be sent to anyone on application to

L. D. HARVEY, President

THE STOUT INSTITUTE
 Menomonie, Wis.

The University of Minnesota

SUMMER SESSION 1922

First Term: June 19 to July 29

Second Term: July 31 to Sept. 2

Registration Days June 17 and June 19

COURSES IN

Trade and Industrial Education
 Teacher Training
 Manual Training

The University of Minnesota will offer a wide variety of courses in the Theory and Practice of Trade and Industrial Education and Manual Training, to both men and women, during its Summer Session.

In cooperation with Dunwoody Institute and the College of Engineering there will be offered approximately fifty shop and trade courses.

Because of its desirable location the University of Minnesota offers a rare opportunity to combine advanced study with a summer of unusual recreational advantages.

For further information or copy of the Summer Session bulletin write to the

Director of the Summer Session
 or the Registrar

University of Minnesota
 MINNEAPOLIS, MINNESOTA

Bradley Institute

Summer Session 1922

First Term June 19 to July 21

Second Term July 24 to Aug. 26

Offers opportunity for study to teachers, supervisors and administrators of the Manual Arts, Industrial Education and Home Economics.

Courses in a wide variety of subjects will be available. Summer credits may be applied toward certificate, A. B. or B. S. Degree.

Send for preliminary announcement and detailed information.

Director Summer Session
Bradley Polytechnic Institute
 Peoria, Illinois

Carnegie Institute of Technology

Summer Session

Courses for Teachers of Manual and
 Industrial Arts

July 5 to Aug. 12, 1922

Exceptional Shop Facilities

Courses in Manual Arts Education, Woodworking, Cabinetmaking, Sheet Metal Work, Drafting.

Other shops open to teachers—Machine, Patternmaking, Forge, Electric Equipment, Plumbing, Automobile.

Instruction given by regular members of the faculty.

Wide range of subjects offered by other departments.

*For catalogue and further information,
 address the*

REGISTRAR, Box M, CARNEGIE INSTITUTE
 OF TECHNOLOGY

Schenley Park, Pittsburgh, Pa.

University of Wisconsin

Department of Industrial Education
and Applied Arts

Summer Session, June 26-Aug. 4

Classes in Manual and Industrial Arts; Drawing and Painting, Commercial Art, Design, Art-crafts Work, Elementary Hand-work; Vocational and Industrial Education. Special attention to teaching methods. Courses leading to B. S. in Industrial Education or in Applied Arts. Graduate courses.

Write for Summer Bulletin

DIRECTOR, UNIVERSITY
MADISON, WISCONSIN

School Shop Installation and Maintenance

By L. S. GREENE

Professor of Industrial Education, University of Florida

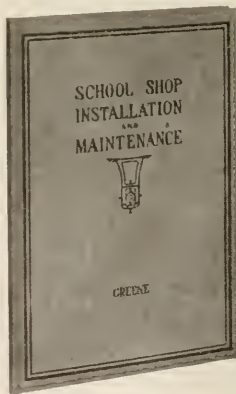

For
Every
Teacher
of
Shop
Work

THIS new book gives selected facts about shop equipment—how to install and maintain properly. It brings together selected facts known to engineers, expert mechanics, and experienced teachers, and presents them so as to be of the greatest help in equipping and caring for school shops. It is, in fact, a hand book of information, rules and methods needed in solving the problems of equipment and maintenance. It gives many facts hard to secure and many more which heretofore could be obtained only thru experience. It shows clearly how to avoid costly mistakes and sooner or later will be worth to the shop teacher many times its cost. *Postpaid, \$1.25.*

The Manual Arts Press
PEORIA, ILLINOIS



FIELD NOTES—(Continued)

regular attendance. In reality they probably needed the very things which are making the courses successful now, namely the short unit course, with its complete body of knowledge and the privilege of dropping out if the next work is not needed, and the added stimulus of beginning new work with the group at regular intervals.

To accommodate young women who were employed during the week, and who could not come at night, Saturday-afternoon classes in cooking, sewing, and millinery were finally started. These have proven so popular that there are many now on the waiting lists and at the request of the members the classes are meeting on Wednesday afternoon in addition to the Saturday afternoon meeting.

INDUSTRIA CLASSES IN HOUSTON PUBLIC SCHOOLS

MR. T. B. FIELDS, supervisor of manual training for the Houston City Schools, reports the following trades as being taught:

(1) Acetylene Welding, with J. W. Barker as instructor. The equipment for this class consists of one Oxweld-cutting, and three Oxweld-welding torches, each equipped with individual reduction valves have been installed. The steel and piping used by this class have been donated so far by firms in Houston that have scrap steel and pipe on hand. This class has done some excellent work and a number of its members are now employed in North Texas where a new oil pipe line is being laid. (2) Another trade class is for sheet-metal workers; this perhaps is the oldest trade class in Houston. It is taught by W. E. Cummings, whose efficient teaching has proved the worth of the class.

Journeymen as well as apprentices attend this class. Master sheet-metal workers are assisting materially in maintaining this class, and the per centage of the attendance is very high. (3) E. A. Prideaux conducts a class in Roof-Framing where excellent work is being done. The men work from blue prints and actually frame roofs of material about one-fourth size. Each rafter however, must be laid out on full size stock to insure the ability of the learner. (4) A class in plumbing and lead burning is conducted by Mr. W. E. Jameson, and is proving to be beneficial to many plumbers who know a part of the trade. The course is divided in three units, soil pipe work, lead pipe, etc., lead burning.

All these classes are conducted in the basement of the City Hall, as there is not sufficient room in any of the public school buildings.

—E. A. FUNKHOUSER.

Manual Training Magazine

MAY, 1922

ECONOMIC CIVICS

FRANK M. LEAVITT

Associate Superintendent Pittsburgh Public Schools

IT MAY BE only an idle dream, but I believe the time is coming when courses of study will be outlined in accordance with principles somewhat at variance with present practices. It seems to me that the outlines of a course of study should include the following:

First, a statement covering the *objectives*, clearly defined and progressively arranged.

Second, directions as to the *methods* of conducting the work of the classes.

Third, a description of the nature of the *activities* which should be expected of the pupils.

Fourth, references to the sources of pertinent *material* in printed form.

Fifth, a statement of the nature and amount of factual *information* which the pupil should be expected to acquire.

While it does not fall within the space limits of this article to present a course of study in economic civics, what I have to say will accommodate itself easily to the outline suggested above.

I take it that this program today implies that economic civics is an integral part of a general social science course, making its own peculiar contribution to the completed product of such a course, namely, a one-hundred-percent citizen.

THE OBJECTIVES

The objectives of a course in economic civics, therefore, are to develop in the individual those interests, ambitions and habits—particularly habits—which will prejudice him strongly in favor of the proposition that a good citizen must be

able to earn an adequate living and thus to become a contributor to the economic stability of his community.

A complete outline of a course in economic civics must subdivide and define this major objective beginning, perhaps, with the purpose of convincing the pupils of the universality of work and the essential divinity of creative effort, and ending with the purpose of leading them to determine that they will choose for themselves the field in which they will make their contribution and not be like "dumb, driven cattle."

Perhaps we might say that a course in economic civics is one phase of vocational guidance, a term which has been misunderstood frequently and misused and misapplied. We should remember that all of our experiences, from infancy to manhood, exercise more or less vocational guidance. Who can measure, for example, the potency of the vocational influence of our ancestors or that of our social environment? We must confine ourselves here to vocational guidance as a school function and, in this relation, it simply means the development of a more intimate, friendly and intelligent co-operation between the schools and that world outside which is to receive, so soon, our school product.

Furthermore, we must try to be reasonable and should remember that social changes come about only gradually. How children distributed themselves last year, as between work and school, or as between the jobs they took on leaving school, is

the best possible index to the way in which other children will act in the year just ahead. Ten years and a world war have not changed greatly the distribution of our young people among the various occupations, as is shown by the 1920 census. We must not expect to revolutionize society immediately, or even quickly by any system of vocational counseling or by giving any amount of vocational information. "The common problem, yours, mine, everyone's, is, not to fancy what were fair in life, provided it *could* be, but finding first what *may* be, to make it fair, up to our means." This is a worthy and an attainable objective.

THE METHODS

So much for the objectives of the proposed course. What, in the main, are the methods by which these objectives may be reached? I have not the temerity to say that I know what are the most effective methods, but the following suggestions are based on the experience of some interested experimenters in this field.

I like to think that words mean something and that, therefore, social science work should be handled as a *science*. Thirty years ago, a scientist and an educator, eminent in his field, said that four words summed up the whole range of the scientific method. These words are, "observe," "record," "collate," "conclude."

We should concern ourselves, therefore, in our course in economic civics, with those social and economic phenomena which are commonly known and which may be *observed* readily by children, but about which they have never been led to think in an unprejudiced and scientific way. It is unnecessary, at this time, to go into details regarding the particular phenomena to be observed, but the range is great, running all the way from personal and family budgets to the

revenue of the United States; from the number of employees in the nearest department store, or factory, or farm, to a study of the United States Census; or from some personally known case of hardship, resulting from the loss of a job, to the national unemployment conference.

Also it is unnecessary to discuss in detail the way in which the children may record and classify the facts which they have observed, or the best methods of reaching pertinent conclusions. These will be more or less obvious if we adhere to the scientific method. It has been observed, also, that social science works thru historical procedure almost entirely and, for our purpose, current history will serve as a guide in these particulars.

PUPIL ACTIVITIES

The important thing, however, is to note how the method suggested above serves to indicate the nature of pupil activities which will result inevitably—the third essential in an outline of a course of study.

While pupils may get much desirable information from printed material, they should be allowed and encouraged to collect facts and figures at first hand. It is remarkable the amount of energy that the average boy will exhibit if given a real "assignment." I remember one boy of about fifteen, a member of a class which had been asked to collect information about some of the railroads entering Chicago. He did not "desist" until he got up to the general manager of the road which he decided to "investigate." It was the road which had the finest station in the city and so appealed to the youngster as being the most worth while. It is safe to say that he got more time and attention and came away with more pertinent information than any one of us would have received if he had gone out on a similar mission.

Perhaps it is unnecessary to say that

it is not the collection of facts that is really important but, rather, it is the habits of mind which this activity engenders, developing a curiosity about things and a power of initiative in satisfying it. It takes us back to the Pestalozzian principle that it is not that children should know the things they do not now know, but that they should behave as they do not now behave. Behavior, not knowledge, is our goal. The class exercise in economic civics, therefore, should serve to *raise* questions rather than to *answer* them. In fact, we do not *know* the answers to many of the questions. And, again, it is not as important to *find* the answer as it is to *seek* it. Dr. Lindley, in his address on "The New Pioneer" said, "The pioneer is one who has a passion for solving problems, not dodging them." Economic civics seeks to develop the pioneer spirit because, after all, each individual life is an adventure into a pioneer situation. It is either that, or it is less than human.

SOURCES OF MATERIAL

Coming to the question as to where to get printed material to be used in such a course, I would suggest that, so far as possible, it should be from sources other than the textbook. Trade literature, magazines, newspapers and government documents are obtainable. It is not necessary or desirable that all pupils make the same studies so long as general principles are made a matter of class discussion.

Reference may be made to textbooks dealing with the subject of vocations or occupations, but it should be clear that to rely on such texts as an important aid in reaching the objectives of this proposed course, or in developing the appropriate methods of conducting it, would be almost in the nature of defeating the very purpose for which the course is given. Such texts must neces-

sarily stress knowledge rather than behaviour and, therefore, tend to develop conservative "dwellers" rather than a race of "pioneers."

FACTS TO BE LEARNED

But the text has its place, tho I believe that what is needed is a laboratory manual rather than a text, giving suggestions regarding work to be done rather than imparting information about work that has already been done by others. I suppose we shall never reach the time when our schools will not demand that the pupils acquire a certain minimum amount of specific information. It is worth while to know a *few* things, even about occupations, and the more effective way to regulate this matter, I presume, will be to settle upon certain texts, or parts of texts, as a statement of the required factual information. It should be observed, however, that this is the last, rather than the first thing to do, the least important, rather than the most important consideration in outlining a course in economic civics.

In this brief outline it is unnecessary to go into details regarding the essential facts to be learned. I presume that these facts would group themselves around such fundamental considerations as the following.

The universality of labor.

Economic wants and how they are satisfied.

Modern industrial conditions affecting vocational choice.

Large scale production and its results, advantages and disadvantages.

Division of labor, specialization and interdependence.

The land and who owns it.

The age-long conflict between capital and labor.

Industrial management.

Modern organization as exemplified in extensive farming, the factory, the railroad and the department store.

The banks and how we use them.

Wealth and poverty, thrift and economy.

Individual and family budgets.

City, state and Federal budgets.

RESULTS TO BE EXPECTED

As pointed out, earlier in this paper, we should try to be reasonable in our expectations. We shall not make the world over, economically or vocationally, by any course of study—at least not within the lifetime of most of us. But since when has the educator refrained from attempting any good thing because it was difficult, or because hope of a signal victory was remote? We are still endeavoring to teach the golden rule and the multiplication table and that a verb must agree with its subject in person and number, altho there seems to be no immediate possibility of becoming one hundred percent efficient in reaching our objectives.

In conclusion, may I venture to mention what appear to be some of the economic rights and duties of a good citizen, and to suggest that we should expect to come as near realizing our aims here as we do in our courses in ethics, mathematics and technical grammar.

The economic duties of a citizen which a student of economic civics should be able to understand:

The right to work and to enjoy the reward of labor.

The right to acquire and protect private property, either real or personal estate.

The right to share in the economy effected by large-scale production and division of labor.

The right to participate in the fixing of the conditions under which he works and the compensation which he receives.

The right of free choice as to what work he will follow.

The right to the same service from public carriers and other public service corporations as any other citizen.

The right to make the most of himself as far as is consistent with the rights of others.

Economic duties of a citizen which a student of economic civics should be able to understand:

The duty to become a self-supporting economic unit—a contributor to social welfare, not merely a debtor.

The duty to try to understand modern economic conditions involving large-scale production, division of labor, evolution of industry, racial problems, wealth and poverty.

The duty to understand and to maintain an open mind toward the fundamentally important problems of capital and labor.

The duty to be thrifty, to save and invest, so as to provide against economic emergency and old age.

The duty to understand the principles of taxation and to play one's full part in providing financial support for the community, be it city, state, or nation.

The education of the human race has been gained through the occupations which it has pursued and developed. They have furnished the stimuli to knowledge and the centers around about which it has been organized. If occupations were made fundamental in education, school work could conform to the natural principles of social and mental development. In short there is nothing of science, history, or art which educational experience has shown to be of worth, which an occupational education would not include.

—JOHN DEWEY.

THE PRESENT STATUS OF INDUSTRIAL ARTS EDUCATION IN OUR ELEMENTARY SCHOOLS¹

II. SUCCESSFULLY CORRELATING AND DEVELOPING UNITS OF WORK AND STUDY

A. H. EDGERTON

Assistant Professor, Indiana University

DESPITE the many encouraging readjustments and tendencies pointed out in the preceding article relative to the purpose and content of profitable industrial experiences in the elementary grades of 141 public school systems, Table II shows that a wide range of opinion still exists as to the actual methods to be employed in realizing any one of these generally accepted objectives. It is to be

are responsible for organizing and conducting the industrial arts activities to select and try out various appropriate methods and practices, as conditions permit, in order that the results may be carefully observed, tested, and compared whenever possible.

It is hoped that the different types of successfully tried units and projects, which are published in the following

TABLE II. 352 GRADE TEACHERS REPORT THEIR RESPECTIVE METHODS FOR CORRELATING THE INDUSTRIAL ARTS TO MAKE ENGLISH (ORAL AND WRITTEN) A TRUE GROWTH OF EACH PUPIL'S EXPERIENCE.*

ITEM	NO.
1. Each pupil is encouraged to become interested in expressing himself in a clear manner during industrial arts talks and discussions.....	126
2. Each pupil is required to write up excursions to industrial plants, make class reports and notes in accepted English for his grade and in a form which has been agreed upon as satisfactory by all concerned.....	98
3. Each pupil studies and, wherever possible, uses accepted business forms and practices to become familiar with the related commercial aspects of the various industries.....	83
4. Each pupil is taught to select and evaluate the most important information from the selected readings:	
a. Those readings which are assigned for the purpose of giving definite information and attendant technic directly related to the construction work done.....	45
b. Those readings which do not directly affect the construction work, but give understanding, insight, and inquiring attitudes of mind in connection with occupational activities in every day life.....	34
	79

hoped that the time is not far distant when careful study and impartial experimentation may aid us in determining the comparative values of our most feasible methods by fairly and thoroly testing them in some definite way. However, until more accurate means have been devised for ascertaining the truth (facts, rather than mere opinions) regarding *what and how pupils from approximately 6 to 12 years of age can learn most effectively and economically*, it behooves those who

manner by special request, will prove sufficiently suggestive to challenge a large number of teachers to try them out as stated or in modified form. These accurately reported units of work have been collected intentionally from individuals having somewhat varied points of view and experience, with the thought that the results obtained and the means employed might interest those concerned and encourage further experimentation with the several plans for realizing common aims or purposes.

¹The first of the series was offered in the April number of this magazine.

*These numbers will total more than 352, as several teachers reported more than one method.

CONTRIBUTIONS TO AND FROM CLOSELY RELATED SUBJECTS IN THE ELEMENTARY SCHOOL CURRICULUM

The far-reaching possibilities in enriching the elementary school curriculum by properly correlating the industrial arts activities with such closely related tool and content subjects as English, geography, history, nature-study, arithmetic,

relative worth in each specific case. It likewise was observed that the content of these closely related subjects was greatly vitalized by utilizing the industrial arts work. Table II indicates a number of these relationships which 352 grade teachers utilized in order to help pupils make their oral and written speech more effective. Altho each subject must

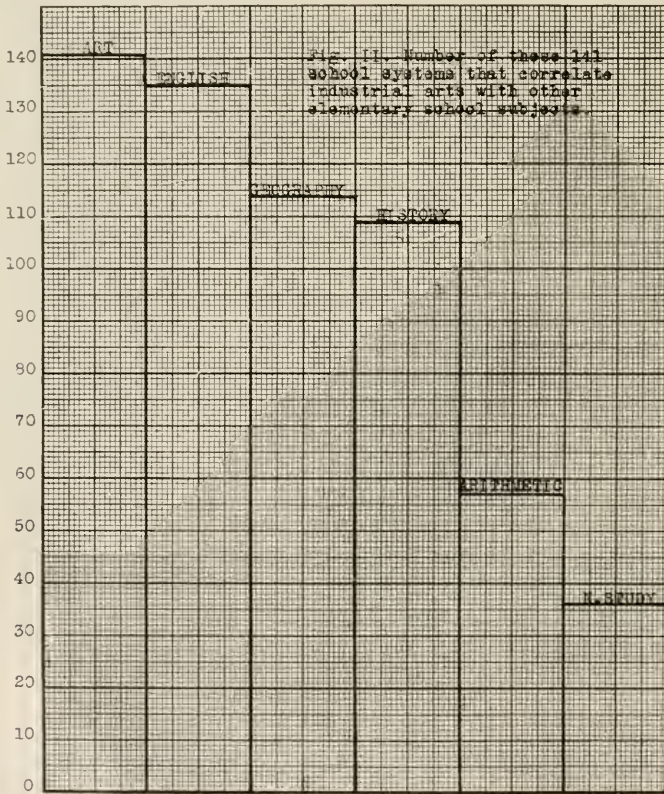

FIG. 2.

and the fine arts were suggested in the introductory article. Figure 2 shows the number of school systems attempting such correlations. In the most effective teaching of this nature observed, each subject was studied and developed in terms of its relationship to fundamental needs. The industrial activity was not only emphasized and conducted in its true perspective, but it was utilized to an extent that could be justified by its

have its own objectives and subject-matter in the classroom, and naturally will subordinate the other in its emphasis at times, nevertheless, any one of the subjects mentioned will lose much of its inherent value provided it neglects to utilize the other subjects advantageously to enrich its own particular aspect of the study.

The following widely varied reports are suggestive of a few of the valuable

correlations which have resulted from resourceful teaching.

MAKING A HOME—GRADE I

EDITH M. PARSONS

Teacher at Youngstown, Ohio

This undirected community work was carried out by a first-grade class of forty foreign children, most of whom were from crowded and unkept homes. My aim was to derive as much pleasure and profit for these children as possible; while the children desired to model a home and its environments.

Conversation first took place concerning the home and uses of furniture. As there were no furniture stores near enough for us to visit, I put colored furniture plates, catalogs, and magazines in convenient places, for the pupils' inspection. After many suggestions and discussions the following was decided upon by vote: (a) Size of house, (b) its color, (c) the kind of furniture, (d) the kind of floor and wall coverings, (e) the place of the garden, (f) the decoration of the front yard, (g) who was to make each part.

The educational values realized from this study were briefly as follows:

1. Language—Conversation and criticisms.
2. Number—counting, costs, and measuring.
3. Nature study—seeds and germination; the value of rain, air, and sunshine; the value of toads, snakes, and insects that live in gardens.
4. Health—value of foods grown in a garden; ventilation and cleanliness in home keeping.
5. Citizenship—voting and cheerfully abiding by the decision of the majority.
6. Writing—the necessary work in planning, costs, and the like.

Equally important with the above were the following social adjustments:

1. Added ability to work together.
2. The appreciation of the good work of another.
3. The ability to take and give criticism.
4. The ability to help one another.
5. The creation of a feeling of responsibility for a completed task.
6. Concentration and independence of thought.

CLOTHING AND TEXTILES —GRADES I AND II

PEARL G. CANDEE

Supervisor of Industrial Arts, Niagara Falls, N. Y.

In the public school, we can no longer separate art and industry from their proper relation to every subject taught in the elementary grade curriculum. During the past two years Niagara Falls has introduced problems in industrial arts into its grade school course of study, endeavoring to give the

child some knowledge of the industry studied and the direct relation of arithmetic, geography, drawing, and other subjects to it. For instance, the making of designs for silk material is preceded by all of the appropriate knowledge obtainable about the silk industry. The following is a typical outline for one subject (textiles), which was used in grades I and II last year.

Grade I.

(a) Discussion of clothing to be worn at various times of year, as to kinds, material, color, etc.

(b) Paper dolls were cut from patterns. Costumes for summer, winter, fall, and spring were made from colored construction paper and trimmed (original designs).

Grades II.

(a) Discussions of clothing worn by people of various lands included

1. Of what the materials are made.
2. How the materials are obtained.
3. Where the materials are obtained.
4. The color combinations used.

(b) Paper dolls were cut from patterns. Costumes representing children of various lands were made from colored construction paper.

(c) This study was correlated with story illustrations and geography.

FOOD AND TEXTILES—GRADES I AND II

CARRIE R. HARMON

Supervisor of Industrial Arts at Lockport, New York

We feel that the industrial arts plan is of greater value than the former courses in drawing and construction work because, first, a new interest is created in the manufactured articles all about us and in all industry; second, in the appreciation of what is good in design in the manufactured articles; third, in the appreciation of the masterpieces in painting and song related to each industry that is studied; third, through its correlation with other subjects in the curriculum, increasing the interest in those subjects. It also increases the interest of the parents in the work of the school, as the children solicit them for information about the subject being studied and for magazines from which to cut pictures to illustrate their subjects.

In each subject in every grade, representation, design, color, and the construction work are included as before. Under food, the studies include the source of supply, the cost, the nutritive value and, in some classes, the method of preparation, setting the table properly, and the artistic arrangement of flowers to adorn it. In the second grade, dishes were recently cut from paper and the napkins arranged on the paper table cloth in their proper places. The proper amount of and the right kind

of food were discussed with them. "A quart a day on every child's tray" is illustrated by posters, as we are at present having a "Milk Week" campaign to show the value of milk to all, and its cheapness as compared with other foods.

Textiles studied for two months included work as follows: first grade, wool; second grade, cotton; third grade, silk; fourth grade, linen; fifth grade, cordage; sixth grade, dress design. The first grade was able to tell the steps in the process of making cloth from the shearing of sheep to the dyeing of the wool or cloth.

We have used as reference books for these studies the booklet "From Wool to Cloth" which is published by the American Woolen Company and sent free to schools, "How the World is Clothed," and other books that were loaned to us by the State Department of Education at Albany, New York.

In the first grade, sheep are cut from paper and mounted on the booklet covers or they are included in posters, or a nursery rhyme such as "Little Bo-Peep" is illustrated. Color and design are included in single form by the stick printing of a design on the booklet cover, or in making a design for a woven rug. Bright-colored yarn in one or more of the six colors is sewed on burlap in the darning stitch. This year, instead, we are making little woolen booties woven on cardboard looms.

ILLUSTRATIVE PROJECTS—GRADE III

GEORGIA AMES KELLEY

Teacher at Hillside School, Berkeley, California

The objective of this project, which was worked out at the Hillside School, was the study of Eskimo life thru the making, dressing, and housing of an Eskimo doll. In order to secure a background for the project, the teacher and third-grade children first secured pictures, books, and relics of Eskimo life. These books and pictures were placed on the reading table, where the children might have access to them at any time after the prescribed work had been completed. During the language period, the facts gleaned thru the silent reading, were presented and discussed by the children. These discussions were in the form of socialized recitations, as the initiative was taken by the children. They also criticized and judged the value of the material presented. During these discussions, the children not only helped correct the poor English by substituting the correct forms, but they also commended excellent forms of expression.

The next step was the organization, on the part of the class, of all the material under a few topics: 1. The country, its climate, resources, etc. 2. The people, their homes, clothing, occupations, etc. 3. The present compared with the past. The

class then divided itself into groups in relation to the topics in which the different individuals were most interested. Each group worked by itself to organize the material of the particular topic into a complete story. This story was afterwards presented to the class, sometimes by members of the group and sometimes by one child whom they chose. Members of the class then wrote compositions and stories upon the various topics. This involved the use of many new words, which the children had selected from day to day and placed upon the blackboard for reference. Besides this fact material, stories, poems, and songs about Eskimo life were collected, and many of them were learned.

During the entire period (about six weeks), the construction work, involved in the completion of the project, was carried on. At each stage of progress, the work of the individual members and of the groups was presented for criticism and suggestion, and the class decided on the final products to be used. The manual work was surprisingly good for such young children. Practically all of the subjects in the curriculum for the third grade were taught thru this project. In fact, the arithmetic was the only subject for which extra work was provided. The children were keenly interested and attacked each new problem, whether it was constructing bases for the Eskimo houses in the manual training room or learning a list of difficult words, with equal enthusiasm and determination.

I. The making and dressing of an Eskimo doll was carried out involving:

1. Studies of pictures and representations of Eskimo life.
2. Modeling an Eskimo doll (a study in proportion).
3. Constructing a doll from brown ticking (designing, cutting, and sewing).
4. Planning the clothes for the doll (cutting patterns).
5. Selecting materials and the making of clothes (overhand stitch used, suggested by primitive method of sewing skins).

II. The making of an Eskimo house consisted of:

1. Studies of pictures of Eskimo houses.
2. Drawing pictures of these on paper and the blackboard.
3. Modeling the house in sand, or from modelling, etc.

III. A sand-table representation of an Eskimo village by the class, included:

1. The original plans which were drawn on paper and transferred to a board. (Each child explained his particular plan to the class. These plans were then dis-

cussed and the best one retained as a working basis. This plan was kept on the board until the sand-table representation was completed).

2. The composition of the representations included:
 - a. Landscape, houses, and people.
 - b. Water, boats, etc.
 - c. Animals, dog-teams, etc.

IV. Individual representations were also made on a smaller scale.

1. A program for the parents which was arranged by the children. (It included a complete unified review of the subject, thru poems, songs, compositions and stories, conducted in the same way as the daily recitations).
2. An exhibit showing all the things made and collected. (These were arranged by the children, who acted as guides to the visitors).

RELATED PROJECTS—GRADE III

GEORGIA AMES KELLEY

Teacher at the Hillside School, Berkeley, California

The objectives of another project were to put content, thru actual experiences, into the terms "cost," "selling price," "loss and gain," and also to test the knowledge of all the addition and subtraction combinations, if possible. The class was studying a community, i. e. small town and farms. It was suggested that the class build a town so that they might buy and sell the different commodities necessary to daily life. Out of this suggestion grew an elaborate community, a town and adjoining farms. The farm produce, cattle and hogs, sheep, poultry, etc. were sold to the markets, and they, in turn, re-sold them to the consumers. The town bank loaned the money to carry on these enterprises, and also took deposits of money. There were public markets, a candy store, a grocery store, a bakery, and real estate firms. Adjoining the town were a chicken ranch, a hog ranch, a dairy, and a fruit and vegetable farm.

For the construction of the town and farms, the class divided itself into groups according to the enterprise which they wished to carry on. The children worked out their own ideas, constructing the stores, furniture, and the articles to be bought and sold. They laid out the farms, built the houses, and made the animals, people, etc. Catalogs were consulted as to fair selling prices, and prices were plainly marked on everything. Posters were used to advertise special sales. Large quantities of money of all denominations were made for the use of the bank. During the arithmetic period,

actual buying and selling was carried on. Each group selected one of its members to "keep shop," while the others went out to trade. At the end of the period, each child figured up his transactions to see what his profits or losses were and settled his account at the bank. Some of these problems were written on the board and the entire class aided in their solution.

The following subject correlations were involved:

I. The industrial arts studies included cardboard and paper construction, woodwork, modeling, sand-table representations, drawing, painting, and printing.

II. The arithmetic work included problems in addition, subtraction, multiplication, fractional parts, U. S. money, reading and writing, and making correct change. This work helped the pupils to understand and use such terms as "cost," "selling price," and "profit and loss."

III. The language work included:

1. Oral expression, thru discussion of project, names for towns, stores, and farms, stating of problems, etc.
2. Written forms in making out bills, writing advertisements, etc.

SHELTER AND FOOD—GRADE IV

MRS. LOIS COFFEY-MOSSMAN

Instructor of Elementary Education
Teachers College, Columbia University
New York City

A group of fourth-grade children in New York City studied the Virginia colony. In reading the simple stories written about these colonists, it seemed that the children were not aware of the real life problems involved. So the teacher questioned them as to what the colonists ate and the sort of houses in which they lived. It was found that most of these children had never seen shingles on a house and had little or no notion as to what a log is. A small model of a log cabin was brought into the room and left where it might be examined by them day after day whenever time availed. This led to questions about making trees into logs and boards. To answer these satisfactorily pictures of trees, lumber camps, and saw mills were used.

At first these children thought that probably sufficient flour was brought in the ship in which the colonists came to this country to supply them indefinitely with bread materials. When some notion of the size of the ship was obtained by comparing it with ships anchored in the Hudson River, they were forced to find another source of bread for these pioneers. They found that corn was secured from the Indians and made first into meal and then into bread. But these children had never

seen ripe corn. A few ears were secured and it was interesting to see their eagerness to help shell it, or even to get a kernel in their hands.

This shelled corn was ground into meal by the pupils and then made into corn bread, the bread being mixed in the classroom and baked in a neighboring oven. Finally the bread was eaten with honey, and thus the children gained some notion of a number of the difficulties which confronted the Virginia colonists.

ILLUSTRATIVE PROJECTS

—GRADES IV AND V

CARRIE B. FRANCIS

Supervisor of Industrial Arts, Indianapolis, Indiana

The fourth and fifth grades in the Ralph Waldo Emerson School of Indianapolis worked out an interesting project during the spring semester, 1920. This project was based on the geography work of the schools with two specific purposes in view; first, to enable the child to translate into terms of his own experience something of the life and conditions of the people whom he was studying, and, second, to stimulate an increased interest in the other subjects correlated with the work.

The story of the project developed was as follows: "An American child was sitting beside the fireplace in his own home. As he sat there, he fell asleep and dreamed a wonderful dream. He was in a great airplane and as he sailed along he saw many strange and curious sights. The child first visited the frozen north, where he saw massive icebergs, the brilliant northern lights, all the strange animals, the snow houses, and Esquimos, who live in them.

"Next he visited a farm in the Temperate Zone. From there he was quickly transported to Japan amid the beauties of the cherry blossoms and the gorgeous, gayly dressed Japanese. In striking contrast, he soon saw the more somber colorings of an Arabian desert with its white gowned Arabs and slow-moving camels. But, most delightful of all, he found himself in the depths of a dense jungle, where he saw peering out from the tall grass all the animals that gave him such thrills when the circus came to town."

The boys in their manual training classes made all of the animals, homes of the peoples, vehicles of transportation, and the like for each scene of the dream. The girls in the sewing classes costumed clothes-pin dolls for the homes. In the art classes, cut-paper landscapes were made to show the settings for the scenes. The pose work was based upon the people living in these homes. At the end of the semester, large stages, replicas of the landscapes, were made, and homes, animals, people, etc. were

placed in their individual settings with the American child in the plane above them flying from the North Frigid Zone to the Torrid Zone.

This work and study aroused the keenest interest and much enthusiasm, which was felt not alone by pupils in the schoolroom, but also by the parents in the homes. This interest in the work served to bring the school and the home in much closer touch with each other. As the grades worked together on this problem, a splendid co-operative spirit was developed. This co-operative spirit should tend to broaden the child's interpretation of life and aid him to more wisely adjust himself to the outside world.

A CORRELATED FOOD PROJECT

—GRADE V

MABEL HUTCHINS

Teacher of Industrial Arts

Grand Rapids, Michigan

This project consisted of the cooking and serving of a Colonial luncheon as part of the Tercentenary Celebration of the Landing of the Pilgrims. It is one example of the natural correlation of industrial arts with the other subjects. The industrial arts included work and study resulting in the pouring and dipping of tallow candles, making soap, investigating Colonial foods, their food values, and composition, cooking utensils and dishes, planning a balanced menu for a luncheon, and finally cooking and serving it correctly. Related art problems consisted of charts showing composition of typical foods, cut-paper designs for table-top and hand-lettered menu and place cards.

The history work involved an intensive study of the Colonial Period and the development of cooking methods; the language work included the writing of papers on the subject-matter, and oral compositions on the lantern slides; the geography studies helped the children to realize the sources of typical foods, the difference between Colonial and modern methods of transportation, and the interdependence of the nations; while the arithmetic was vitalized by practical problems in marketing, comparing costs of food and fuels, figuring food values, averages, and percentages.

In the hygiene class early methods of sanitation were compared with modern methods, the value of food to the body was emphasized, and (along with the making of soap) personal cleanliness was taught. The related science allowed time for simple chemical tests for food elements; the nature study was responsible for classifying the kinds of food native to the community, and a consideration of agriculture was made to allow for a study of the methods of production. Finally, the children were taught table manners, table service, and courtesy.

CLASS PROJECTS—GRADE VI

A. A. CAIN

Ethical Culture School, New York City

At the Ethical Culture School, New York City, we have found that a study of the elements of electricity interests the pupils of our sixth grade. A choice is permitted in making a motor, telegraph, Bell telephone, wireless telegraph, or electric toaster. Men whose names are prominent in the field of electricity are studied and as much information as possible collected. This also creates a keener interest in the geography work when transportation, and modern facilities for travel are discussed.

Subjects are related in many ways, and the teachers in the different departments assist one another as occasions arise for developing some part of the work to a point of greater educational value. To illustrate this, I shall refer to a particular case. The sixth-grade class teacher had reached the point in geography where travel and lumber are associated. One of the shop teachers had been interviewed and arrangements were made for a talk on lumber, concerning where some of the common kinds grow, how to tell the different kinds, and something about the commercial lumber industry in general. This information cleaned up some mathematical difficulties by pointing out the sizes of boards and the commercial methods for figuring costs. At the same time, the shop benefited by showing the pupils the structural elements of wood, as there is seldom time during shop periods for such discussions.

From our experiments, it would seem that the work has a much greater educational value when there can be the closest possible relationship between the activities of the classroom and the work of the shop.

STIMULATING A STUDY OF
ARCHITECTURE—GRADE VI

L. A. HERR

Supervisor of Elementary Industrial Arts
The Lincoln School, New York City

Thru the study of medieval history and a trip to the Metropolitan Museum, the sixth-grade class became interested in historic ornament. They decided to make some of the most typical and beautiful of the historic forms in plaster. The aim was to make these as true to the best examples as possible. Both teacher and pupils collected drawings and pictures from which each pupil made a choice of the particular ornament he wished to make. Borders such as egg and dart, the bead and button, and the guilloche were the choice of

the majority of the pupils, altho some selected different kinds of ornament.

The work fell into three natural divisions, namely:

- (1) Modeling of the desired form in clay;
- (2) The making of a plaster mold from the clay model;
- (3) The making of the finished cast from the mold.

Each pupil began by making a full-sized pencil sketch of the form which was used as a guide in the modeling. When the forms had been partially built up, several pupils cut templates to assist them in securing greater accuracy in their work. In preparing the temporary walls about the forms and in mixing and pouring the plaster, the pupils obtained good results by working in small groups and assisting each other. This work led to an extended study of architecture from the classic to the modern period. This study of architecture was successfully carried on by means of class discussions, sketching, lantern slides, and visits to typical buildings.

RELATION BETWEEN
CONSTRUCTION PROBLEMS AND
INTELLECTUAL CONTENT

The majority of the primary teachers report that they experience little difficulty in stimulating their pupils to select and develop suitable construction problems to aid in the elementary industrial arts studies. On the other hand they have observed that the ability of these younger children to understand is usually far greater than their technic. While a much greater degree of precision and accuracy can be encouraged beyond the third grade, it is exceedingly important for all teachers of elementary industrial arts to distinguish clearly between those manual aspects of the work which are intended primarily to result in motor skill (power over technic) and those which contribute mainly to general mental development.

Mrs. Coffey-Mossman, Instructor in Elementary Education at Teachers College, Columbia University, has referred to the relation which might well exist between the subject-matter and the construction work as follows:

To be worthy of a place in the school program, industrial arts should be able to show that it has a body of thought of its own. Some have regarded it as merely the handmaiden of the other school subjects to make them clearer and more interesting. If this is true, the work should be embodied in the respective subjects, just as maps, charts, lantern slides, and stereographs are used now. But industrial arts has a subject-matter of its own. It is a study which has to do with the activity of the race in transforming raw materials to meet definite needs. . . . The growth of the race in developing better ways of meeting these needs; the materials which have been found best suited to the needs; the limitations, the qualities, the methods of producing, and the supply of these materials; the devices for making the things needed with their underlying scientific principles; and the effect upon man both of making and of using these products constitute a rich field of human activity worthy of study.

The making of a thing best enables one to understand it. To study the need as a problem until one can invent a way to meet the need is good, but the child cannot, in his short life, rediscover all the ways in which man has met these needs. He should then make the projects involved in his study whenever there is no easier way to get the idea as clearly as he should have it. This will necessitate evaluating every project upon the worth of the idea which it gives, upon the amount of time required, and upon the possibility of a quicker way of securing the idea—thru reading about it, being told, seeing pictures, or seeing some one else make it. If the "inner felt" series of sensations of which Professor James speaks is the only way to get the correct idea, then take the time for making the project. Projects in this subject exist then for the sake of clarifying ideas and giving the child a real understanding and appreciation of the industrial activity."^{*}

^{*}Coffey-Mossman, Lois, "The Organization of the Curriculum in Industrial Arts in the Elementary School," Bulletin of the Teachers College Alumni Conferences, Columbia University, New York City, 1913, pp. 80-81.

Nearly all of the teachers questioned on this subject disagree with the following statement, which was made recently by one of our well known educators: "The educational value is meagre in most of the so-called elementary grade industrial work, because it is relatively devoid of intellectual content." Invariably, they have stated that thru the group and individual projects, several of which are included in these articles, they are demonstrating daily the presence of such intellectual content by having the pupils not only participate in manipulative work, but also gain an intelligent appreciation of what the various problems, methods, and conditions mean in terms of historical development, social worth, scientific changes, and industrial growth. In other words, these purposeful activities are constantly challenging the pupils to think, speak, write, and read, as well as to use materials and tools to construct serviceable and interesting products.

After reading these suggestive reports dealing with the purpose, content and method of various correlated units and projects, we must agree that the teachers concerned are seriously attempting to adapt both the construction work and the subject-matter to *those situations and responses which promise most in determining social conduct, thru the development of proper habits, attitudes, and appreciations.*

(To be continued)

TEACHING BATTERY CONNECTIONS

W. F. PERRY

FOR some time past, the writer has been working out various methods whereby subjects in Ohm's Law may be "put over" to members of the class in such a manner as to leave a lasting impression upon their minds. This paper will deal with the teaching of the connecting of cells in various combinations.

The material required for the teaching of this lesson requires nothing more than four wooden sticks, each being about $\frac{1}{2}$ " square and approximately 6" long.

The first battery connection to be considered is the series connection. It is well to impress upon the class members that the word series is not wholly an electrical term, but is used in their everyday conversations on other than electrical subjects; viz., a series of ball-

and the width; it is just three times the length of one of the sticks and exactly the same width, Fig. 2.

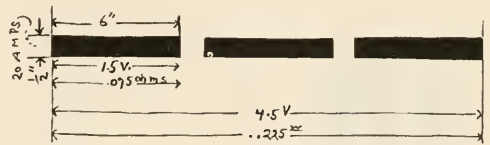

FIG. 2.

This is the "jumping-off point," and it is but a simple matter to explain that the single stick represents a single cell of battery. Its length represents the voltage as well as the internal resistance, and its width represents the current capacity of the cell. Having related these terms, again place the sticks, "one after the other," and ask the class to think in electrical terms and give the total output in volts, amperes and the resistance in ohms. There can be no doubt as to a great number of the answers being correct. This illustration should be followed with a number of practice problems on this type of connection.



FIG. 1.

games, and such like. They should thoroughly understand that the word means "one after the other."

Sketch on the board three series-connected cells, as in Fig. 1, giving the data regarding one of the cells, E, I, R. Give the boys a chance to think by asking them what the total output of the cells will be when connected in this manner. The answer naturally will be somewhat varied—a few of them showing, however, evidences of real thought. Take the sticks; give the dimensions of any one of them. Place them end to end, or, in other words, one after the other. Question the class as to the total length of wood and its width. Everybody has become interested because he has suddenly discovered that there really is something concerning this problem about which he knows. Everybody knows the length

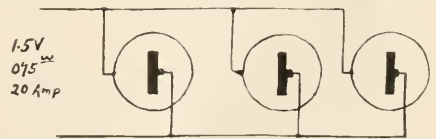

FIG. 3.

When the first type of connection has been well mastered, the boys are ready for the next combination; viz., the multiple connection. Explain that the word multiple should always convey to the mind the phrase "side by side." Make a sketch of three cells connected in multiple, as in Fig. 3, giving the data of one cell. Place the sticks "side by side" and ask for the total dimensions. They are the same length as that of one stick, but three times the width of one,

Fig. 4. Thinking again in terms electrical, show that the voltage of the three cells would be no greater than that of one cell while the width or capacity

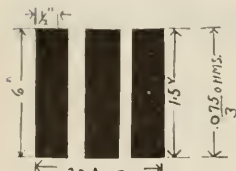

FIG. 4.

would be multiplied by three. Owing to the fact that there are three multiple paths over which the current may travel, the total resistance has become equal to the resistance of one cell divided by three or approximately $\frac{1}{3}$ of the resistance of one of the cells.

Practice problems of multiple battery connections should be given until this method has been well enough learned to proceed with the next combination, namely, the series multiple connection.

Sketch, as in Fig. 5, the connections of four cells. Have the boys consider the problem in hand and give opinions as to what the output may be. Place

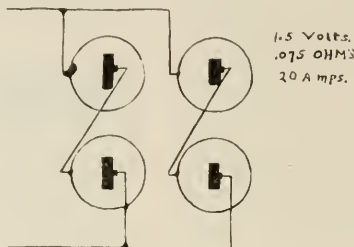

FIG. 5.

sticks as in Fig. 6, and again relate the lengths and widths with voltage, resistance and amperage. The problem has become very simple. The total length

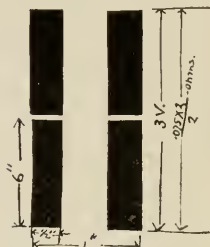

FIG. 6.

being twice that of one stick, therefore, the voltage will be twice that of one cell. The total width is twice that of one stick, therefore, the amperage capacity is twice that of one cell. The total resistance in this combination becomes twice the resistance of one cell divided by two.

The writer has found that the use of this method brings excellent and lasting results. It is, however, quite possible that other instructors have already made use of such an idea. If any reader has been angling about for a good method by which to "put over" these lessons, let him try this one.

THE EASTERN ARTS CONVENTION

CLARLES A. BENNETT

AFTER several years of absence from the meetings of the Eastern Arts Association I attended the convention at Rochester, April 6th to 8th. As might be expected I found myself making comparisons with meetings previously attended. I recognized the fact that the organization is now much larger than it used to be, and the interests more varied. In the old days when Henry Turner Bailey, Walter Sargent, James Hall and Dr. James P. Haney were the leading spirits, all the members had more in

common. There were few sub-divisions, never more than two sections, and all the members seemed to be fairly well acquainted with each other, or in a fair way of becoming so. Now, with the sections on art, industrial arts, elementary industrial arts, household arts, part-time education, and vocational education, the Association is made up of groups that are not much acquainted with each other, and seem to have very little in common except the spirit of educational progress and loyalty to the organization. This

diversity of interests seems to be a necessary result of expansion, but it was clear that the officers planned several events to help break over these lines of separation and make for solidarity and for mutual acquaintance. The same policy pursued further will probably yield still greater results.

One of the noticeable facts concerning the convention was the persistently aggressive work being done by the secretary, Frank E. Mathewson, who has carried on a campaign of advertising in which he and his teachers and pupils at the William Dickinson High School of Jersey City addressed 12,000 envelopes and sent out 42,000 pieces of printed matter. If Mr. Mathewson can be induced to continue such a campaign thru a series of years and, if the officers continue the policy of building up the Association that was carried forward by President Reagle and his associates this year, the Eastern Arts Association will multiply its power and influence many fold.

For the manual arts and industrial teacher the city of Rochester is a particularly fortunate place to hold the convention, because of its large number and variety of school shops. There were two large modern junior high schools, a pre-vocational school for sub-normals, a continuation school, the famous Shop School, and the shops of the Mechanics Institute. All these could be seen in operation by visitors.

THE PROBLEMS OF THE JUNIOR HIGH SCHOOL

The program of the convention was so varied, and so many sections were in session at one time, that no one person could do more than get a single cross-section of it. My cross-section might be called a junior high school cross-section, for at almost every session I attended the problems of the junior high school came in for a major part of the discussion. The

background for the discussion of this topic was laid at the first session by the address of Professor Arthur Dean entitled "Dedicated to the Spirit of Adolescent Youth." He was followed in the same session by Arthur Irving, principal of a junior high school in Springfield, Massachusetts, who gave an address on "Organization of the Arts in a Junior High School." Then came two industrial arts sectional meetings devoted entirely to junior high school problems and a considerable part of an evening program. The art and household arts sections also discussed junior high school problems more than those of any other single section of school work. It might be presumed, therefore, that the arts in the junior high school were approached from about every possible angle. This seemed to be true. Some of the viewpoints seemed ultra-conservative, while others were progressive enough to suit the most radical. Still others were indefinite enough to please everybody, except possibly, the critical university professor and the fellow who discounts the value of inspiration and social and intellectual contacts, and comes to a convention expecting to have handed out to him a program of projects and methods just suited to his own community. But the major part of the discussion was sane and forward-looking and helpful.

To me the big out-standing idea of the convention was that the junior high school must be a school especially adapted to dealing with children of the adolescent period. It must be different from the grades below it and certainly different from the senior high school above it. To merely adopt a departmental scheme of teaching is not to make a junior high school—far from it. The junior high school is a new type of school based upon what modern psychology and child study have shown to be natural periods

of development of normal children. In order to be this, it must provide for the activities, the development of varied interests, the freedom for expression, the sympathies that are needed during this period to insure the best development. Such a school must, therefore, make extensive use of the industrial arts.

Speaking on this side of junior high school work, Arthur Dean emphasized the great importance of the right kind of teachers. He insisted that it takes a *real man* to fire the imagination of adolescent youth and that anything less will not solve the teaching problem of the junior high school.

He added that it also takes a *real teacher*. He said that in the past we have too often had normal courses to learn how to teach, but not how to teach boys and girls. Much of the industrial arts work is now what he called "motivated book work." "There is no use in trying to motivate a study of the process of getting flour from Minnesota." He said, "Go on a hike, and all the rest is added." He recommended the formation of clubs to stimulate freedom of choice in activities and pointed to the Washington Junior High School of Rochester as an admirable example. Here, there are sixty-five such clubs, and definite school time is given each week for the meeting of these clubs. He recognized that it is impossible to do just the same thing in all sorts of places, but the spirit can be the same. The smaller the community, the larger the opportunity for the industrial arts teacher. As an example of excellent work in a small community, he pointed to St. Johnsbury, Vermont, where the teacher of industrial arts is also the scout master and where the work of the school is found all over the community. In such a case, the equipment of the school is not merely in the school building, but

partly in the homes and elsewhere in the community. The community environment is the workshop, not merely that part of it which is under the school roof.

He commended the practice of recognizing special accomplishment. He approved club insignia and honorable mention badges. "The psychology of the age is to work for recognition. The adolescent period is the button period. (Adults are in the money period). There must be recognition in the form of badges and the like. It wouldn't be a junior high school if you had the most wonderful printing plant in the world and didn't have a school paper, with an editorial staff, business manager, advertising manager, and all the rest. In a junior high school study is minimized and activity is stressed." Information must be "interlocked with social and spiritual growth."

William R. Ward of Trenton, New Jersey, spoke very effectively on the "Co-ordination of Academic Work and Shopwork." He first declared that it is of great importance that the teachers of academic work and of shopwork recognize their common problems and mutual responsibility. Secondly, he recommended conferences of teachers to map out work and fix objectives. Thirdly, and with emphasis, he recommended that teachers visit each other's classes. He would have teachers spend three periods a week in such visiting. In this way the academic teachers get information that helps them in co-ordinating their work with the shopwork and the teacher of shopwork gets methods, and learns the limitations of some of his pupils.

Arthur Irving said that when his school first started, the idea prevailed that those students who couldn't do anything else went into the industrial arts course. After a while more students were found

in industrial arts courses, and now there are about 50 per cent more in this course than in any other. In fact, 45 per cent of the entire school are now in that course. He pointed out that one of the great advantages of the industrial arts course in his community was that it was an effective "finding school" and that the

practical arts work has developed in each child an appreciation of his own worth."

Following the discussions of the spirit and methods of the junior high school came a session devoting considerable attention to the practical details of courses and equipments. Robert A. Campbell, assistant supervisor of industrial education in the state of New Jersey, spoke of the danger of over-equipment. He thought it unfortunate to equip a shop entirely at one time. He would like to see an equipment grow as the need grows. He was certain that subjects other than woodworking should be taught. He seemed to be favorable to a "composite shop" under certain conditions, but he said 18 boys is enough for one teacher to handle in such a shop.

The climax of my interest in this session was reached when Edwin F. Judd of Montclair, New Jersey, who was introduced as "the electrical wizard in school work," told us about the work of his "wireless club" of 46 members and described the wireless apparatus made by pupils in the Montclair school shops. This wireless work, and the inter-school boat races and boat construction also described by Mr. Judd, seemed to embody the very spirit of the junior high school as described at the first session of the convention. A significant fact about all these discussions was that the words "vocational" and "prevocational" were not used. Instead of these the vocabulary of the speakers was well stocked with such words as "adolescent," "activities," "clubs," "hikes," "normal development." How I wished that G. Stanley Hall, John Dewey and William Hawley Smith could have been present! Their souls would have rejoiced. They would have realized that their bearing witness to the truth had not been in vain.



POSTER USED IN ADVERTISING THE CONVENTION.

students who do go from this school to the vocational school go with a definite aim.

The junior high school certainly does hold many pupils in school longer than they would be if there were no such school. But, in addition to this, thru the industrial arts the pupils learn something of the value of work; they learn that for each one there is a kind of work in which he can be successful. "The



EDITORIAL REVIEW FOR THE MONTH

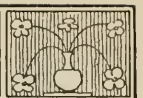

THE PROJECT PROBLEM

LAST November there appeared in this Magazine an article on "The Project Problem" by Allen D. Backus, which has attracted widespread attention. Among the letters that it has called forth are the following:—

Dear Mr. Editor:

In the November issue of *The Manual Training Magazine* I read with interest the article under the title of "The Project Problem," and felt constrained to write an expression of somewhat different views.

The writer of the article makes it plain that any successful manual training teacher should have well founded convictions on the question of whether the pupils should all be *compelled* to work on the same problem or whether each should be *permitted* to select his own problem under guidance.

I believe with the writer that it would be assuming a great deal to say that one was infallible in his particular choice of method; but the sequence of his argument savors of an attack upon the teacher of the "individual method," and infers that such a teacher is incompetent to do otherwise.

From my experience I have observed that many teachers take the line of least resistance and this is found in the group problem. I have taught both ways, and do so yet when a real project presents itself. I find it much easier, from the teacher's standpoint, to teach a class when all are making the same problem than when many problems are being made. The work is more mechanical and requires less thought on the part of both teacher and pupil.

The question is asked; "Why should one boy develop his initiative thru the making of a chair while another develops his thru the making of a table?" The answer is that the boy should be influenced to make something for which he has a definite use and if he is required to make the same project as every other boy he and his "three" brothers may overstock the home with toy airplanes or some other "pet hobby" of the teacher who has an iron clad course of problems.

I feel that no course should be outlined that does not permit of flexibility, as sometimes the project is the result of a real need in the home or schoolroom, and just as in anything else that we learn, there are certain principles that must be followed, and after they have been grasped they may be applied to any project.

My experience has taught me that the teaching difficulty lies not in the making of projects but in teaching principles. It is an accepted fact that the school is the place where a child should be taught to think, and whether it be manual training or some other subject, if the pupil is not taught to think his way out of difficulties, there is something wrong with the method used. It is no easy matter to teach a boy to use his head, but I contend that the individual project is a greater means to that end than the one problem method. I don't know that I can offer any authority upon either method but observation and experience have taught me that the boy is much more dependent upon himself if his problem is different from the others. The fact that the "education of grammar school boys" is involved makes it much more urgent that they realize that they are learning principles and not problems. It is true that the selections of the first boys in the class are suggestive for the other fellows, but the teacher who is "up and ready" can influence a new design on the same thing that will cause much thinking on the part of the boy.

Reference was made to the boys who must stand and wait for the teacher of the individual project method while he is giving some other boy a little attention; I am wondering what is done to take care of the variation in speed that is found in any group of boys when the same problem is being made by all. Because a teacher can influence the boys to imagine they like the thing they are making is no argument that the method is the better method.

I thoroly believe that some teachers can use either method and get results, but I am firmly convinced that more teachers would fail if they tried to present the "individual method" than if they tried to teach the "same problem" method.

The argument in favor of the "one problem" method was once presented to the writer by a teacher who used it for years, his chief defense was "It is easier for the teacher."

The advocate of the "one problem" method has said that "the teaching of many things thru the project method is one of the duties of the shop instructor." My contention is that the project method requires that a real need exist, and where the need exists thinking will be required to bring about results. If every teacher of shop or other room will do his part to create thinking among pupils the other things will care for themselves nicely. All this talk about filling a class with "a love for the thing they are doing" and "weaving

around it stories of romance and industry," particularly if they can see no need for the project, reads well in a magazine article but looks different in a manual training shop.

Inference is made that many individual projects have nothing in common: All projects involve *tool processes*, and certainly one cannot hope to teach much more than the intelligent use of these processes toward useful ends.

The acquisition of skill is very limited in the brief time allotted to manual training and therefore the short time in the shop should be spent directing the thoughts of the pupils toward doing something worth while and making something useful.

In conclusion I must agree that the welfare of the boy should be uppermost in the mind of the teacher and, because I agree with this sentiment, I must still continue to advocate the individual method as the better for developing individuality.

J. F. DENNIS,

Instructor of Manual Training,
Public Schools, Wilkes-Barre, Pa.

My dear Mr. Editor:

I am so favorably impressed with the article, "The Project Problem," by Supervisor Allen D. Backus of Newark, New Jersey, in the November issue of your magazine that I am impelled to write you my commendation of it. Very frankly, I do not find much in the industrial magazines of the country on the theory and method of teaching that I can unreservedly commend. I have felt all along that the educational magazines which deal with the teaching of industrial subjects have been leading us "amuck" by advocating methods which are wholly impractical and unworkable under the average schoolroom conditions. Seeing so much that I cannot agree with, I feel that it is proper to encourage the writer of an article which argues such sound educational principles.

In the average sized manual training class the individual project method is unworkable and the wonder is that school men have not learned that long ago. It is physically impossible to deal singly with the members of a class. While the teacher is helping one boy to a clear idea of his special problem, the nineteen other boys are apt to be on the "waiting list" with the resulting chaos so often seen in industrial classes.

Mr. Backus is quite right in saying that it is rare that a boy does *not* want to make what the rest of the class is making. I have tested this out thoroly on a large number of manual training students, and I have learned that the average boy would rather work on an exercise similar to that which the others of the class are making than to work out a special model. If some of the educators

of this country would get into actual contact with classroom work they would find that many of the finely spun educational theories which they insist are right are often wholly wrong, and this doctrine of the individual project on the basis of personal interest is one of them.

My experience in teaching a few thousand boys leads me to say that fully 95 per cent of them prefer the class model to the individual project. I am sure this holds good thruout the junior high school years.

It is distressing to contemplate the great waste of time and the resulting chaos which the individual project method involves. I think that the industrial teacher could well learn from the academic teachers in this respect. There is no more reason why each one in a manual arts class should be working independently of every other member than a class of the same size in biology should be cut up into units, some studying zoology, some physiology and some bacteriology, and all grouped in the same recitation.

Moreover, it is wholly unnecessary that individualism should characterize industrial teaching. From the standpoint of interest it is certainly not needed. From the standpoint of strong, systematic teaching too much individualism is certainly a very great handicap.

If we do the most effective teaching we must systematize our work, and that precludes the individual project save in the advanced classes of the senior high school.

Very truly yours,

E. L. STEENROD,

Instructor, Manual Arts,
Parker High School, Dayton, Ohio

PROGRESS IN TEACHING SHOPWORK

ANOTHER letter came to the office of this Magazine recently which deserves more than passing notice. It was from one of our re-discovered long-time friends. For twenty-three years Charles F. Thorpe of Los Angeles, California, has been a constant reader of the *Manual Training Magazine* and he has kept his volumes unbroken all this time. In the letter referred to Mr. Thorpe says,

"While attending our Los Angeles State Normal School I became very much interested in our phase of school education and took advantage of your Magazine for new ideas, inspiration, and guidance. After serving my year's apprenticeship in the city schools at Whittier, California, where I began with

cardboard construction, using Trybom's book as a guide, I went to San Francisco for over six years, when Cree T. Work was just organizing the manual training instruction. Mr. Work was fresh from Columbia University and I owe a debt of gratitude to him. Manual training was just beginning to break away from the influence of the sloyd school and we were actually making usable things. The schools were very much bound up with a course of joints and were always getting the boys ready to make something they never made."

These last sentences will suggest to some other "honor-roll" readers that there has been substantial progress in manual training during these twenty-three years. To the earnest worker changes seem to take place very slowly, but when it is possible to compare the questions under discussion and courses given twenty years ago with those of today, progress is clearly evident.

VOCATIONAL TEACHER TRAINING IN CALIFORNIA

IT IS generally conceded that, educationally speaking, California stands near the top of the list of progressive states, but it is not so generally known what a far-reaching program of vocational education is being built up in the state under the commissioner of vocational education, Edwin R. Snyder, nor to what extent he is being backed up by the University of California. It was only a few years ago that Robert J. Leonard was taken from Indiana to become director of the division of vocational education at the University of California. A little later he took from Indiana his former assistant, Edwin A. Lee, who had just served as president of the Vocational Education Association of the Middle West. And last summer he called back to the Pacific Coast, Ben W. Johnson, who was then state supervisor of industrial education and city director of vocational education in Wilmington, Delaware. Mr. Johnson was formerly in Federal Board work in San Francisco.

He is now the University's supervisor of classes for teachers of trade and industrial subjects, and has immediate direction of the work in the San Francisco Bay region, while John G. Miller is in immediate charge of similar work in the Los Angeles district. Working with the latter center is an extension center at San Diego, and with the San Francisco center there are extension classes at Stockton and at San Jose. Thus a comprehensive program of training vocational teachers is supplementing the industrial arts teacher training of the state normal



DEAN M. SCHWEICKHARD

schools. In this way California is planning for its future work in vocational education.

Some Eastern and Middle State friends of Mr. Johnson regretted very much that he should be tempted back to the Pacific Coast, tho that was to be expected because several previous efforts had been made to hold him on this side of the Rockies without results.

Years ago Mr. Johnson was one of the students in Dr. C. M. Woodward's

manual training school in St. Louis. Then he went to Oberlin College and from there to the saw mills of the far Northwest. Before long he went into school work and gradually built up the manual arts instruction in the city of Seattle until it became famous thruout the country. He started some of the very first industrial work centers in grammar schools which just preceded the coming of the present junior high schools. His interest in new educational problems has always been keen and it is not strange that, after working on problems all the way from the kindergarten to the trade school, he should now be engaged in the greatest problem of all—the preparation of teachers who will make or break the future success of vocational education. For after all, the greatest handicap that any new department of school instruction encounters is a shortage of competent teachers. Mr. Johnson is an inspiring leader and will do a great work in this new field.

A NEW SUPERVISOR IN MINNESOTA

DEAN M. SCHWEICKHARD, who for the past two years has held the office of director of industrial and vocational education in the public schools of Clinton, Iowa, has been appointed supervisor of industrial education for the state of Minnesota.

Mr. Schweickhard graduated from the State Normal School at Mankato, Minnesota, in 1912, and taught manual arts in the same state for two years. After this he entered the College of Engineering of the University of Minnesota for one year, during which time he taught classes in the Minneapolis night schools. In 1916 he received the degree of Bachelor of Arts from the University of Wisconsin, having majored in industrial arts. During the war Mr. Schweickhard served as an instructor of machine gunnery in the

School of Aeronautics at the University of Illinois. Previous to accepting the position which he is now leaving, he was for a time assistant professor of industrial arts at Purdue University.

Mr. Schweickhard will assume his new duties about June 15.



BEN W. JOHNSON.

MANUAL TRAINING SHOP NOT A PLAY ROOM

PART of still another letter bearing on methods of teaching is given below:

My dear Mr. Editor:

I am forced to write you and tell you how much I enjoyed the article of the month in your Magazine—"The Boy's Course or the Teacher's Course" by Frank W. Cheney. To my mind it seems the most sensible article that I have read in a magazine on the subject for some years. I hope that it will be, or rather that it is, the result of a reaction of the sober after-thought of teachers in woodworking.

It seems to me that we ought sooner or later to face the fact that woodworking, like arithmetic, is made up of a number of elementary facts to be mastered; that no course is a course unless it covers the ground; that the manual training shop is not a play room in which the main object is to cater to the savage instincts of the boy and to the demands of the principal to make an "exhibit."

ORVILLE J. GRISIER,
Instructor of Industrial Arts,
Aurora Schools, Colorado.

A POINT OF VIEW

PRESENT STATUS OF PART-TIME SCHOOLS

NO! I am not ill. I haven't indigestion. No one or nothing has come into my life to cause pessimism. I can prove an alibi.

But, I am professionally sick at heart. And it is over the present status of the continuation and part-time schools. Theoretically, they offer bread and wine; that is, nourishment and stimulant. Practically, and generally speaking, they give stones and water; that is, nothing plus a forced cold plunge.

There is no use mincing matters. The best work is in Wisconsin and Boston. The reasons are Cooley and Evans. The fair-to-middling work is wherever those in charge have caught the spirit of these two men. The poor work is everywhere else. Such do not know where they are going, and they are not even on the way. They cross the pedagogical road with about the same amount of gray matter and forethought as a hen in front of a car.

Here is a movement full of possibilities that is going to the "jolly bow-wows." It is in the hands of people who lack imagination. It affects employers who lack interest. It is given to pupils who do not want it. It is taught by teachers who do not know what they are doing or why they are doing it. It is suffered to live by superintendents who have not either courage to kill it or brains to breathe the breath of life into it.

You doubt me. I can tell you facts. Not one, but a hundred. In one school the trade preparatory work is only wood-work. (What would we do without our old standby?) In another, the "shop arithmetic for the boys" consists of using Dooley's "Shop Mathematics for the Girls." (Nothing against my friend Dooley, who is the New York correspondent for the *Manual Training Maga-*

zine.) In another, the boys get bench-work in wood when every member of the class whom I interviewed wanted something else and had excellent reasons for his desires. In another, the "industrial hygiene" consisted of reading a series of "health books" adapted to fifth graders. In another, a mixed group from all lines of employment were given algebra of the $(x^2 + 7x + 12)$, $(a^6 + a^4b^2 + a^2b^4 + b^6)$, $(a^2 + b^3)^5$ order. (And this was in a building in which is located the office of one of the best (supposedly) directors of vocational education.) In another, the supervisor told me that the continuation school pupils were a nuisance. "Why!" he said, "a girl came to me and informed me that she had just 62 hours to stay with me. Now, what can I do with her in 62 hours?" In another, some of the children travel ten miles to attend the "plunge" and to get the "stones." If they are absent they are hailed before the police courts. Yet, in this same city there are thousands who are not obeying the law at all. (A case of penalized for good intentions and bad practice, and set Scot-free for bad intentions and no practice.)

But why go on! It sounds like a dirge and reminds one of the funeral of a man of unsocial habits where no one could be induced to officiate and where the friends of the departed remained silent until one spoke up and said, "Anyhow, he was a *good* drinker."

Now theoretically, why is the continuation and part-time movement a good thing? *First*, because it provides for "learn and earn." *Second*, because youth (boys in this case) want to be a part of the work-a-day world. *Third*, because the school alone can never provide the type of productive instruction that commercial and industrial life offers. *Fourth*, because the mental school sponge of

youth, saturated as it is by constant pouring in, needs squeezing and working between the fingers of actual accomplishment in order to have the efficiency one expects and gets by using a bathing sponge.

These points are equally good. There may be more. The last one is especially good. I believe in useful labor. I endorse work where there is an objective, especially when the subject can see that objective. To go to school forever is not to get an education. To work forever without knowing what it is all about is to miss something. To have your mind filled by working your mind, to have the liquids of thought and feeling poured into the mental sponge, to have the hand of expression and experience press and work the sponge is to get the most out of education. The school end of the continuation system plus the work end equals education, or $S+W=E$.

An all-day school of the regular book order has the equation $S=E-W$; that is, it is educational minus the values of useful work. Just work alone for youth has the equation $W=E-S$; that is, it is educational (perhaps) but it lacks the values which are included in schooling. Those who would raise the compulsory school age regardless of labor values are in error. Those who would hold youth in a bookfull-laborless school are at fault. Those who would try to make the school alone truly imitative of production are counting chickens from wooden eggs.

Now practically, why are we failing in this continuation and part-time movement? *First*, because we jammed thru a law without knowing what we were up against. *Second*, because we took the idea from Germany where it works, and put it into America where it does not work. (Note that Milwaukee and Cincinnati have a large German-American population, and that here the work is

good.) *Third*, because we half-heartedly execute what we whole-heartedly legislated. *Fourth*, because we have little or no separation in classes of youth by occupation, and hence, little real correlation. *Fifth*, because we have mighty few teachers who can teach youth. (They teach subjects only.) *Sixth*, because the movement is attempting to teach too much; that is, it aims at trade extension, trade preparatory, continuance of elementary and secondary subject-matter, industrial and personal hygiene, related subjects, economics, industrial laws and "such other subjects as may elevate the mental, vocational and spiritual aspects of working young people."

Ye gods and little fishes! (nearest New England approach to profanity). A program for 4 hours a week! It is a comparatively simple matter in Germany. For example, there is a group of lens-grinding apprentices working in a shop. They come to a school for a few hours a week and receive technical and related subject-matter in a working laboratory which has the atmosphere of a lens factory, and are taught by a man who carries the atmosphere of a teacher-technician. The same holds true of individual classes for machinist helpers, office assistants, messenger boys, waiters, etc. Germany is an industrial nation. We are a live-by-wit nation. The German boy and girl stay put." The American youth never stays thru his "put" and is constantly moving on. Germany has "crafts." We have "industries." Germany has continuation schools. We have time-servers in a cold plunge.

Now, what are going to do about it? That is easy to answer. Unless these schools improve we are going to give them up. Should we? No. Will we? Yes. It's easy to give them up and, unless they are better, it will be best to do so, and substitute a junior high school

system for children up to the age of sixteen. This latter system to care for the needs of adolescent youth, to provide vocational information, and to assist towards vocational direction (notice my wording of the last).

I think I can see the handwriting on the wall. There is to be in America a more earnest endeavor to save the children from what Martin of Massachusetts in 1906 called the wasted years (14-16). This State Commission, of which he was the secretary, wanted to save these working children by sending them to vocational schools. This movement has resulted in prevocational, intermediate industrial, industrial and vocational schools, which, frankly speaking, is still a struggling proposition.

The 1920 continuation movement which swept the nation (i. e. swept the legislative halls through the efforts of Lewis Carris) was intended to return the 14-16 working youth to school for a few hours a week. At best it seems to be a struggling proposition. Instead of wasting their two years in work, children now waste their hours in continuation schools. Of course, if the junior high school is to spell waste both in the school idea and in the work ideal, then there is no hope for the 14-16 either in school or in work. The 14-16 year old child is still a problem whether he is in a poor day school, in a poor job or in a poor continuation school.

Now, if we are to keep the continuation and part-time education, I most earnestly suggest that we clear the decks of all rubbish and start again. My program must be briefly stated. *First*, a division into two general types of work: (a) 14-16 for the continuing of the educational ideals of general education, (which include occupational and personal hygiene, personal and community citizenship, a vocational living, and assistance in vocational choice) (b) 16-18 part-time work

where there is a much closer co-ordination between work experience and book studies than is possible in the (a) type. *Second*. Extension of compulsory time of attendance of such pupils. (Wisconsin has the right idea.) *Third*. Give more of the school work in the shops and stores and offices where young people are employed. *Fourth*. Recognize that the work done by some youth in some occupations is educative because of the organization and the nature of the work and excuse such youth from attendance at compulsory classes. *Fifth*. For the 14-16 group find teachers of boys and girls who know adolescence and who can keep live things alive instead of attempting by special training to learn how to make dead things live—even an animated skeleton will not interest youth. (Such teachers are not practical tradesmen or inexperienced females. They are 100% people who hate "Regents," outlines, examinations, courses and supervisors.) Unfortunately, they have already left the public school system. *Sixth*. Make the schoolrooms attractive with something more than sunlight, plants or Greek temples. They need mottoes, exhibits, experiments, newspapers, commercial prints, etc. *Seventh*. Stir youth. Do not squeeze it. Never mind about information "which you can use sometime." Give them something they can use now. *Eighth*. For the 16-18 old youth segregate groups into the various major occupations and correlate with a vengeance. Get the blue-prints, materials, exhibits, trade papers, experiments, etc., for adequate co-relating.

And when it cannot be done right, give it up. We cannot hope to succeed in this most important work by merely passing legislation and writing a few state bulletins. Come now. Let's quit our bluffing. Some one will soon call us.

—ARTHUR DEAN.

WASHINGTON CORRESPONDENCE

FEDERAL BOARD FOR VOCATIONAL EDUCATION

IN JANUARY I reported the resignation of Mr. Carris, and the next month I should have mentioned the fact that, at the January meeting of the Federal Board for Vocational Education J. C. Wright, was appointed acting administrative head. Mr. Wright continues also as chief of the industrial education service, and will hold both positions until the election of a director, which will probably occur at the April meeting of the Board.

Another appointment, effective March 1st, was that of I. S. Noall as associate specialist in industrial education, who was formerly state supervisor of trades and industries in Utah. Mr. Noall's work will be chiefly in the field of the continuation school, and to this he brings valuable experience from a state which has one of the most comprehensive plans of compulsory school attendance. Some sort of public supervision over children of school age is exercised thruout the entire twelve months of the year in Utah.

In a recent discussion of the future of the continuation school Mr. Wright made the interesting statement that the real problem is in the small community. The large city school system, if it decides to have continuation schools at all, can organize them on a basis permitting the employment of an expert as director and a staff of trained teachers, and provision of necessary buildings and other facilities. The continuation school in the small town, however, can often have but one or two teachers; its support is not always vigorous or intelligent; and the general atmosphere of the school system is frequently unsympathetic toward experimental work of any kind.

OTHER CHANGES IN PERSONNEL

GEORGE A. MCGARVEY, who has been for several years a member of the staff of the Minnesota state department of education, has accepted an appointment as regional agent of the Federal Board for the North Atlantic states, effective April 1st.

Charles R. Allen resigned as special agent, March 20th, to take a permanent position at Dunwoody Institute, Minneapolis. Dr. "Charlie" Prosser and "Charlie" Allen, the team that played many successful engagements together when the early history of industrial education was in the making, are united once more.

Frank Cushman, until recently regional agent for the North Atlantic states, has been transferred to the Washington office, and will carry on the work Mr. Allen started in foreman training.

Miss Carrie A. Lyford, supervisor of home economics at Hampton, Institute, Virginia, has been employed by the Federal Board to make a special study of home economics in schools for Negroes. She will spend three or four months visiting schools in the Southern states. Miss Lyford was director of home economics in the Illinois State Normal University, at Normal, Illinois, and later specialist in home economics in the U. S. Bureau of Education, before going to Hampton Institute three years ago.

The chiefs of the various services of the Federal Board now are: J. C. Wright, acting administrative head and chief of the industrial education service; Dr. C. H. Lane, agricultural education; Earl W. Barnhart, commercial education; Anna E. Richardson, home economics; John Kratz, industrial rehabilitation.

FINANCIAL SUPPORT OF VOCATIONAL
EDUCATION LARGELY A STATE
AND LOCAL MATTER

MR. WRIGHT called my attention the other day to some figures in the last annual report of the Federal Board, which show the proportions of the funds for vocational education which come from federal, state, and local sources, respectively. In 1920-21 the following amounts were spent for vocational education under the provisions of the Smith-Hughes Vocational Education Law:

Local expenditures	\$5,182,818.	48.7
State appropriations	3,086,680.	29.0
Reimbursement from federal funds	2,380,353.	22.3
TOTAL	\$10,649,852.	100.0

A little less than one-half of the funds, therefore, came from local communities, and a little more than one-fifth from Federal appropriations.

FOREMAN TRAINING IN VIRGINIA

A PROGRESSIVE step has been taken by the Virginia state department of education, in the appointment of I. R. Anderson as special agent for the promotion of foreman training in industrial establishments. Mr. Anderson comes to Virginia from one of the DuPont plants. He was one of the three men who, with Charles R. Allen, made the original experiment in the Harrison plant in Philadelphia in 1918, and he has been engaged in this type of work continuously since.

—WILLIAM T. BAWDEN.

IN FOREIGN COUNTRIES

VIEWPOINTS CONCERNING SECONDARY
AND HIGHER EDUCATION

THE Labor Party in England is protesting against the proposal of the Government to cut educational expenditures one-eighth. A demonstration against such action was held early in March by the Workers' Educational Association and representatives of workers' organizations, trade unions, co-operative societies, educational bodies and teachers. In an address Arthur Henderson warned the Government against proposed economies in secondary education. He pointed out that in the last eight years the number of pupils on the rolls of secondary schools has nearly doubled. He said that some persons seem to regard this sign of educational awakening on the part of democracy as a national disaster, and stand ready to deliver a blow of the axe in the hope of checking this movement of intellectual emancipation of the worker's child.

A few days later Sir Robert Blair, the

chief education officer of the London County Council, discussed the Labor Party program at University College. His statements concerning the item on secondary education are reported as follows by the *Times Educational Supplement*:

In regard to secondary education, which the Labor Party proposed should be free, he said he had never been able to reconcile himself personally to free secondary education. He held that provision should be made for all children capable of profiting, but he held equally that there were many children who were not capable of profiting by an education up to 18 years of age, and there were some not capable of profiting by an education up to 16 years. He maintained that for those the continuation school, with part work and part school, gave both pupils and teachers an opportunity of beginning again and trying to find an education along different lines.

Viscount Haldane addressed a meeting at the King's College Education Society recently and is reported thus:

Lord Haldane said he did not think we should get a fully intelligent nation, and as a consequence a fully intelligent Government, until we got the influence of the university student permeating the

whole nation. The universities were to-day rising to a new function in the nation. A great change had come over the people; class barriers were disappearing, and the people were claiming the same rights, at all events, as regards knowledge. The working classes were becoming keen about the higher knowledge. They were beginning to realise that the important thing in life was the mind, and with this came the claim for the higher knowledge. He saw in the future a class of university student who would find a career in the missionary effort of going out into the industrial centers and preaching the higher knowledge to the workers. It would be a new kind of work, akin to that of the clergy, but would be pursued from the standpoint of the university. With a democracy such as he had in view, the workers would earn not only better wages, but there would be fewer strikes and lock-outs and disturbances, and the productivity of the nation would increase.

EXHIBIT OF CONTINUATION SCHOOL WORK IN LONDON

EARLY in March an exhibition of the work of the pupils in the London day continuation schools was held in the Whitechapel Art Gallery. This exhibition was held to counteract the influence of many mis-statements that had been made concerning the aim and the character of the instruction given in these schools. It had been said that these schools do not teach anything useful.

The exhibition gave the school authorities an opportunity to emphasize certain facts concerning these schools: (a) They are for students who are not well served by the ordinary curriculum, (b) "Practical work—the education of children thru their creative propensities—is probably more educational for most children than is brain work pure and simple," (c) Vocation-finding rather than vocational training is an aim of such schools.

The following is quoted from a newspaper report of the exhibit:

Many of the first batch of young persons were

indifferent, and sometimes unruly. The principals report now that these traits have disappeared, that there are no disciplinary difficulties, and that all new entrants readily form courteous and studious habits, owing partly to the impressions passed on to them by the young persons who have left the schools and partly to the bearing and example of these senior students. Every week sees many additions to the list of employers who are cooperating with the schools and are selecting their employees from the schools. The appointment to the school by the Ministry of Labor of an employment officer has also been a great asset in enlisting the good will of parents. Principals take pains to make the school hours elastic enough to meet industrial requirements, and their efforts in this direction are appreciated. It is true, of course, that the cleverest children leave the elementary schools for central and secondary schools. But there are many others who have ability without the examination temperament, and it is for this type of young person for whom the day continuation schools offer many educational opportunities. There are 35 day continuation schools in London.

It might be mentioned that in America, at least, not all young persons who have "ability without the examination temperament" are found in continuation schools.

USE OF COLORED PLASTER CASTS

ACCORDING to *The Schoolmaster*, one English school has departed from the usual practice of using only white plaster casts for study in art classes. Instead, they have colored the casts so that they will appear more nearly in the original colors.

Casts of Gothic stonework, for example, are tinted with a light stone color. Casts of wood-carving are most unreal when still white, but effectively imitate wood when skilfully treated. The close approximation to actual reality thus gained adds to the students' realization of the varied treatments of ornament, as suitable for specific materials. Some Greek and Egyptian specimens have been restored in full color, and have an excellent effect. Perhaps the most interesting casts are some from old heraldic subjects, which, with the true colors blazoned on them, shows heraldry as it really was.

Another pessimist is the pupil who nails as well as glues his dovetails.

—THE SCHOOLMASTER.



PROJECTS, PROBLEMS AND NOTES

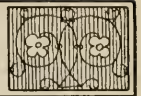

A PANTAGRAPH

IN the making of many articles such as coping-saw toys, it is often necessary to enlarge or reduce drawings. A device for doing this is shown in Fig. 1. This pantagraph can be made in the shop as well as used in the shop. The framework is pivoted about a point *a*. The pivot is a spike driven up thru a scrap of 2" x 6", with another small piece of 2" stuff serving as a washer to hold the framework at the right height. The whole framework is then free to move about this pivot. At *b*

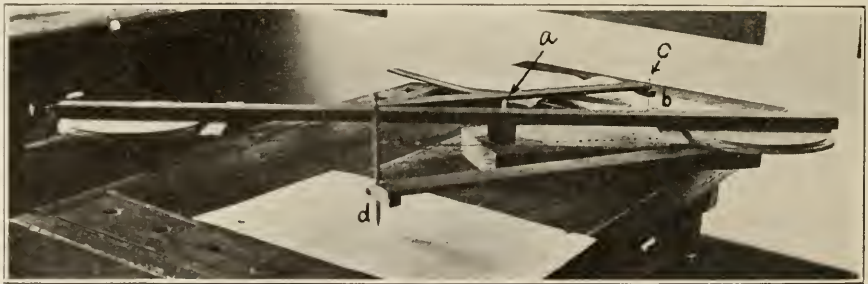

FIG. 1.

is the drawing to be enlarged or reduced, over which the tracing point *c* moves. The pencil *d* traces on paper the outline followed by the tracing point.

Figures 2 and 3 give an idea of the general appearance of the device from the top and the bottom. The main bar, *a*, has attached to each end, a disk *b* and *b'*, made up of two circular pieces of $\frac{1}{4}$ " lumber: a smaller one serving as a pulley, a larger one as a flange. A wire, *c*, passes over the smaller part of each disk, as a belt passes over two pulleys. The wire passes entirely around the smaller part, a loop being brought thru a hole and anchored as shown at *d*, Fig. 3. It is very important that there should not be any slipping of the wire on the disk. It is held in place by the outer part of the disk, the flange, and by tin guides attached to the crosspieces *e*. The disks are free to rotate, and by means of the wire belt, are compelled to rotate together.

Screwed to these disks, are two arms, *f* and *f'*, Fig. 3. Two blocks, *g* and *g'*, carry the pencil and tracing point, and may be attached to either arm at any of the points 1" apart. The arms are offset from the center line of the bar, so that pencil and tracer may be on the center line. It is important

that these points *move* on the center line of the disks, as they are changed to new locations, and not simply *be* on that line at a given setting.

In order to keep the wire taut, and the arms parallel, two turnbuckles, *h* and *h'*, Fig. 2, are necessary. These can be made from an old bicycle spoke and two battery thumb-nuts, as shown in Fig. 4. The threaded end of the spoke is cut off to a suitable length and an eye bent in the end. A thumb-nut is next slipped over the end, and the nipple screwed on so that its small end slips into

the thumb-nut. It is then soldered to the latter. From the remaining part of the spoke a yoke is formed, with an eye in one end, and the two free ends opposite bent so they may be soldered to a second thumb-nut as shown. When the threaded part of the spoke, *a*, Fig. 4, and the yoke, *b*, are held from turning, the nut, *c*, may be turned to either take up or loosen the wire. Picture wire was used as a belt.

In using the pantagraph, the blocks with pencil and tracer are screwed to the arms so that the ratio of the distances from their centers to the centers of the disks will be the same as the desired ratio of reduction or enlargement. If enlarging, the pencil will be placed at the greater distance. The bar is then pivoted at a point such that the distances from it to the centers of the disks shall be in the same ratio as the arms. Such holes may be drilled to suit the builder, as at A-J in the working drawing. When these conditions are met, the pencil, pivot, and tracer will always be in the same straight line no matter how the disks may be rotated. Drawings may be copied the same size if the bar is pivoted at its center, and the arm lengths made equal.

If the ratios of the arm lengths, and the pivoting

point, are not made equal, some very interesting, and occasionally useful results may be obtained. As an illustration of this, the following will serve: It was desired to make use of several sizes of French

ed with files. The ratios of arms and pivoting distances were then made to be different and some very different and useful shapes obtained. The variety of shapes thus obtained is almost unlimited, be-

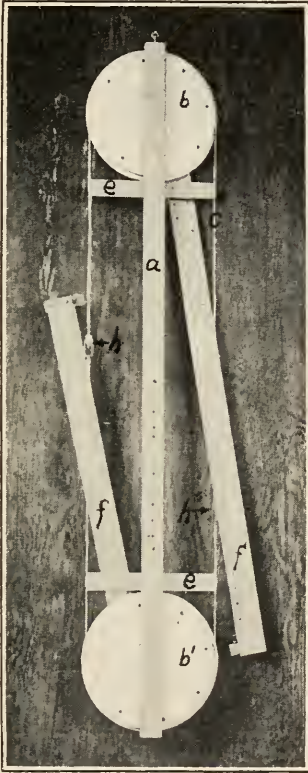

FIG. 2.

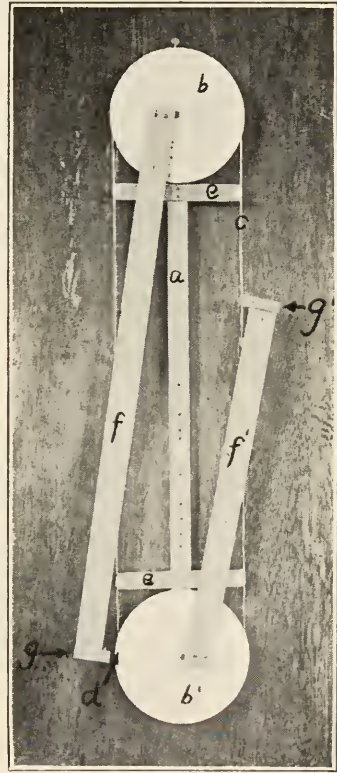

FIG. 3.

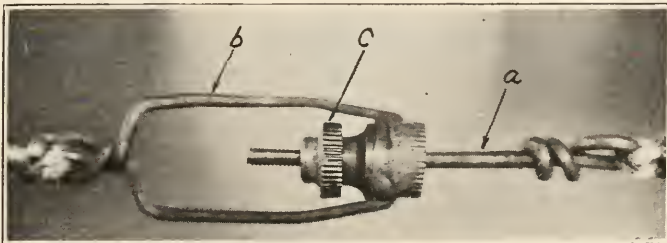
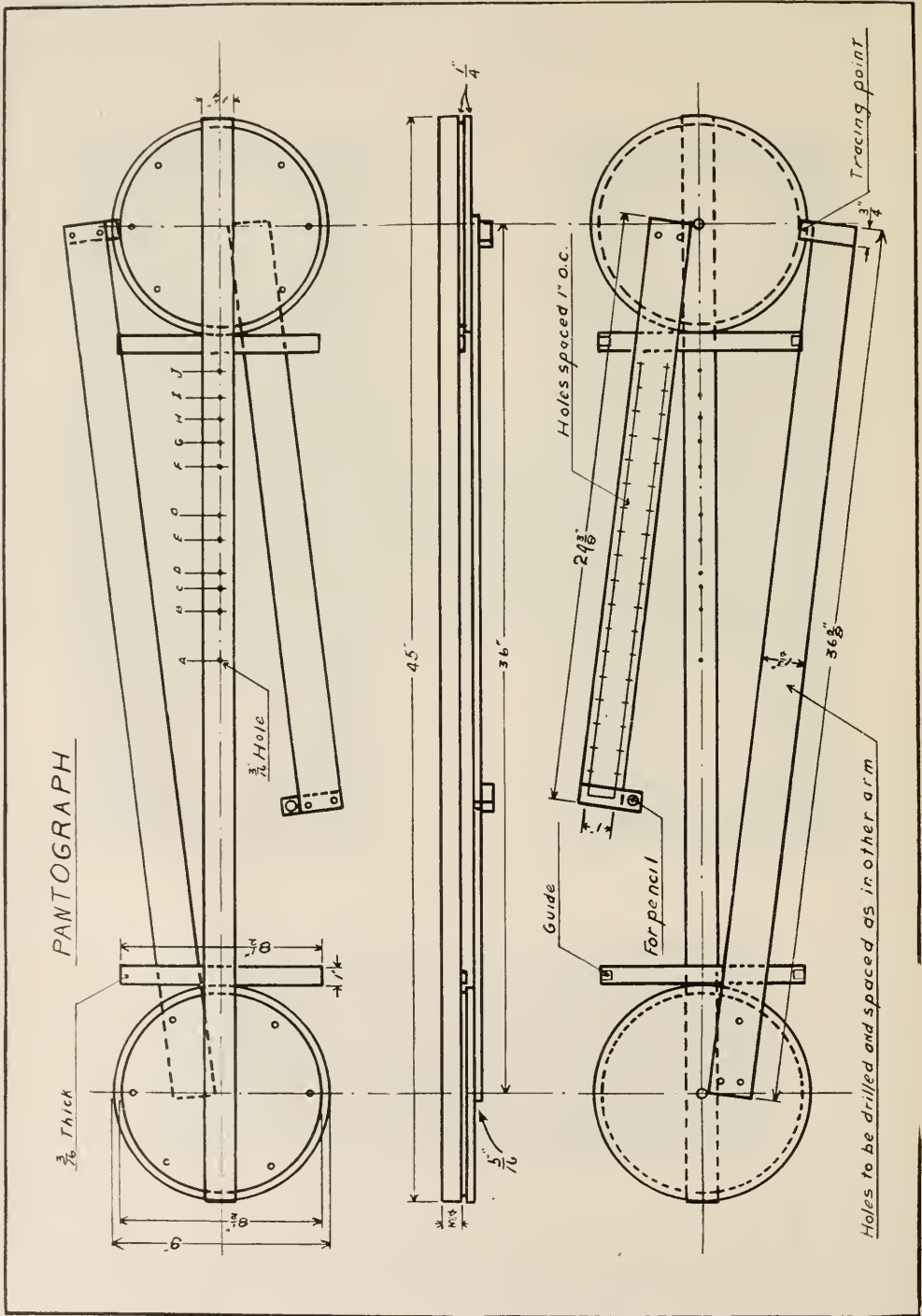

FIG. 4.

curves for the drawing of the lines of a model boat. To buy such a set was considered too expensive. So an ordinary curve was tacked down to a drawing board, and by means of the pantograph several enlarged outlines were traced off on galvanized iron, to be cut out with snips and cold chisel, and smooth-

cause the initial position of the arms, when beginning these unequal ratio tracings, has a great effect on the final result, as well as the different combinations of ratios.

—R. W. WAGNER,
Consolidated School, Webb, Ia.



CHAIR LAMP.

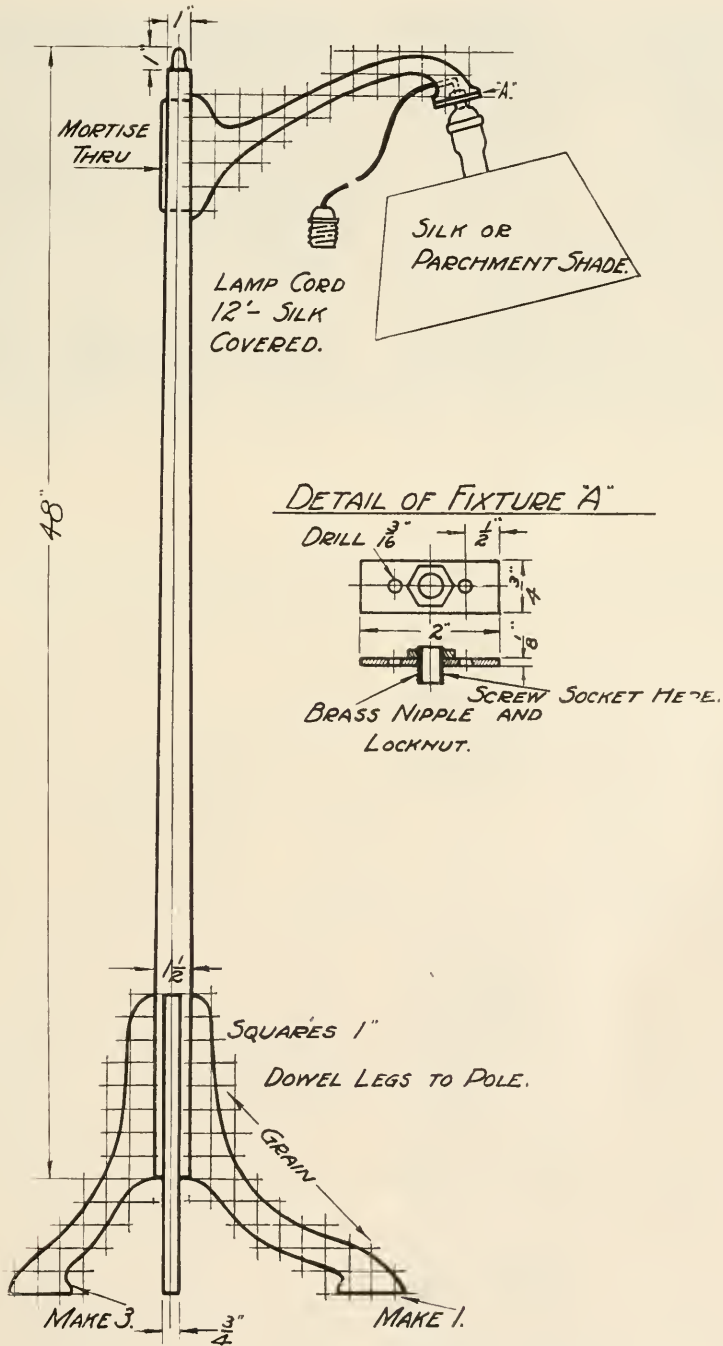

HAROLD R. WISE.
INSTRUCTOR IN WOODWORKING
PROVIDENCE, R.I.



HAROLD R. WISE OF PROVIDENCE, R. I. HAS FOUND THE DANCING SEE-SAW TO BE A VERY DESIRABLE GRAMMAR- GRADE PROBLEM. WHEN MADE FOR THE KINDERGARTEN CHILDREN IT SEEMS TO MEET THE WILLIAM MORRIS DEFINITION OF ART; IT GIVES JOY TO THE MAKER AND TO THE USER.

DANCING SEE-SAW.

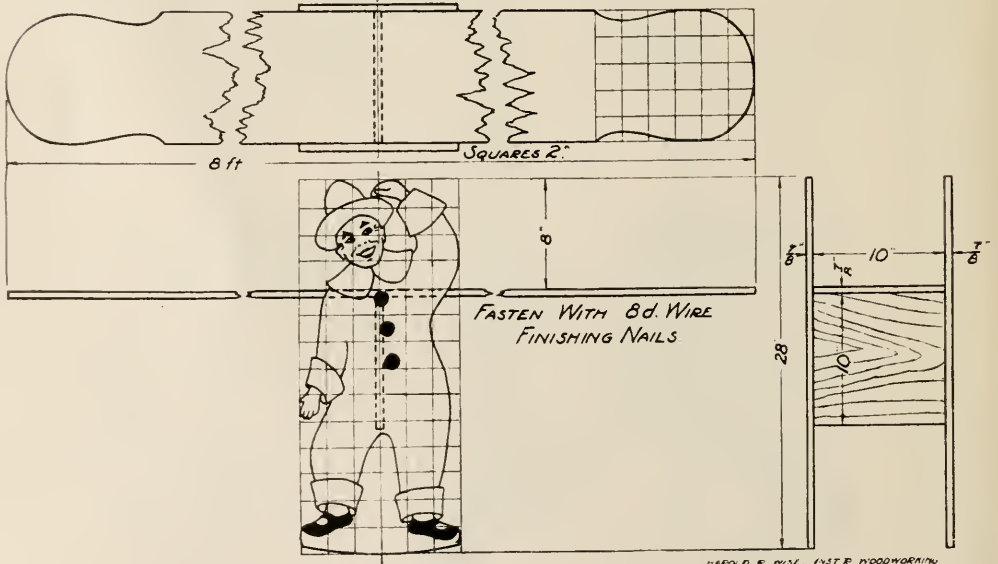

HAROLD R. WISE, INST. IN WOODWORKING
 PROVIDENCE R. I.
 11.26.21

CURRENT PUBLICATIONS

Mechanical Drawing. A first year course by Willard W. Ermeling, Ferdinand A. P. Fisher, and George G. Greene, all instructors in Chicago high schools. The Bruce Publishing Company, Milwaukee, 1921. Size $6\frac{3}{8} \times 8\frac{1}{4}$ in. oblong; 80 pages, paper cover; price, 45 cents.

This book is a compilation of problems, notes and various devices which the authors have found desirable to place in the hands of first-year high school students in teaching mechanical drawing. In general, the methods suggested and the problems given are in accord with good current practice in teaching the subject. Some of the illustrative devices are quite new, and very suggestive. These devices, rather than the problems, give special character to the book.

Wood-turning. By William Fairman. J. B. Lippincott, Philadelphia. Size $5 \times 7\frac{1}{4}$ inches; 150 pages.

This is one of the "Woodwork Series" of English books issued by the Lippincott Company. Probably American readers will find their chief interest in the chapters on spiral turning, not often treated in books on turning, and the one suggesting designs for table legs, columns, posts, spindles, finials, etc.

Electrical Equipment of the Motor Car. By David Penn Moreton and Darwin S. Hatch. Published by the U. P. C. Book Company, 243-249 West 39th St., New York, 1920. Size 5×7 in.; 466 pages; 360 illustrations; price \$3.50 postpaid.

The purpose of this book is to discuss comprehensively all the various lighting, starting, and ignition systems that are used on the different cars now on the market.

The first chapter deals in a practical way, with the fundamental facts bearing upon the service of electricity, such as electrical circuit, amperes, electrical pressure, etc., in order to give the average reader a basis for the interpretation of the discussions which follow. Particular emphasis is laid on the many electrical systems used in the Ford car.

In the back part of the book are more than one hundred wiring diagrams for various cars.

How to Teach Agriculture. By Ashley V. Storm, professor of agricultural education, University of Minnesota and Kary C. Davis, Knapp School of Country Life, George Peabody College for Teachers. J. B. Lippincott Co., Philadelphia, 1920. Size $8\frac{1}{4} \times 5\frac{1}{2}$ in.; 434 pages; 223 illustrations.

This is a handbook for teachers of agriculture in all kinds of schools, from the one-room building to the normal school, and a textbook for prospective teachers in teacher-training courses. The book is the outgrowth of many years of experience in teach-

ing and a careful study of the needs in this field. The eighteen chapters in the book begin with four on teaching agriculture in general. These are followed by chapters on the special departments of agriculture, such as agronomy, animal husbandry, dairying, etc. The twenty-four pages of Chapter X are devoted to "How to teach Farm Mechanics, Engineering and Shopwork."

Coal Manual. By F. R. Wadleigh. Published by *National Coal Mining News*, 834 Union Trust Bldg., Cincinnati, Ohio. Size, $6 \times 4\frac{1}{2}$ in.; 84 pages; price, \$2.50.

This handbook is intended to supply the need for accurate knowledge regarding coal. It is intended for salesmen as well as buyers and users of coal. It gives facts concerning the structure and chemistry of coal and its geographical distribution. It discusses such subjects as samples and sampling, analysis, ash, clinkers, sulphur in coal, the various uses of coal, coke, gas manufacture, boilers and furnaces, suggestions for firing, stokers, combustion, etc., etc.

Such a manual ought to find a place in industrial school libraries.

Dangers and Chemistry of Fire. In two volumes: One for primary schools, the other for grammar schools. By Dr. Clarence Mavis, late pyrologist to the State Fire Marshal of Ohio. Prepared under the direction of Vernon M. Riegel, state superintendent of Public Instruction, Columbus, Ohio. Size of each, $9 \times 6\frac{1}{4}$ in.; 78 and 87 pages respectively.

These books were prepared to meet the requirements of a state law in reference to fire lessons and fire drills in public schools. They discuss a great variety of details in a series of lessons on such subjects as, carelessness with matches, the kerosene lamp, kindling a fire, fires from chimneys, leaking gas, fighting fire, electricity, etc. These are lessons in applied science that every child needs to know but often does not.

A Course in Mechanical Drawing. By Louis Rouillion, director of Mechanics Institute, New York City. The Norman W. Henley Publishing Company. Size $6\frac{1}{2} \times 7\frac{3}{4}$ in., oblong. Price, \$1.50. This is the fifteenth edition, revised and enlarged, of a book first published in 1896.

RECEIVED

Wisconsin's Educational Horizon. A series of pamphlets on education including such subjects as the following: *Technical and Trade Training Through the Continuation School*, by Edward A. Fitzpatrick; *The Rehabilitation of the Handicapped*, by George

H. Hartridge: *Two Courses in Woodwork*, by Edward A. Fitzpatrick. *Handicrafts in Construction Schools*, by Jennie McMillin Turner and Edward A. Fitzpatrick: *Fundamentals of the Construction and of the Course of Study*, by Edward A. Fitzpatrick: *Shop Education*, by Edward A. Fitzpatrick. This series of pamphlets will be of special interest to many teachers and superintends of vocational education.

The Detroit Educational Bulletin, No. 5, June, 1921. A Preliminary Study of Standards of Growth in the Detroit Public Schools. By Paul C. Packer and Arthur E. Mehlman, with an introduction by Stuart A. Courtes.

Vol. 5, No. 1. "The University and Education." A discussion of the significance of the new school of education. University of Michigan, an education in the state.

Proceedings of the First Pan-Pacific Educational Conference, Honolulu, August, 1921. Dr. Frank F. Bunker, Secretary, Bureau of Education, Washington, D. C.

Principles and Vocational Rehabilitation. Published by the State Industrial Accident Commission. Frank H. Stephens, Director of Vocational Rehabilitation, Corvallis, Oregon.

Education in Forestry. Proceedings of the Second National Conference, New Haven, Connecticut, December 1920. Bulletin No. 44, 1921. Issued by the U. S. Bureau of Education.

Public Education in North Carolina. A report of Public Schools Commission of North Carolina. Published by the General Educational Board, 70 Broadway, New York, New York.

The Intermediate School in Detroit. By Charles L. South, Arthur Mehlman and H. R. Hartridge. December number of the Detroit Educational Bulletin published by the Board of Education, Detroit, Michigan.

Part-Time and Combination Schools. Annual Report issued in Part-Time Education Series No. 4 by the Division of Vocational Education, University of California. This includes *Part, Single Week Combination School of Eugene, Ten Experiments in Voluntary Combination Schools in England, German Combination Schools, Compulsory Trade Combination School of Munich*, and a short list of publications on part-time combination schools report.

Federal Catering Technique. A course of instruction for use in public schools by candidates for certification. Part I prepared by Raymond F. Case. Published by the U. S. Department of Labor, Washington, D. C.

Foreign Condition of American Education. By W. J. O'Brien. Bulletin No. 4, 1921. Issued by the U. S. Bureau of Education, Washington, D. C.

Some of the Things the Cleveland Public Schools are Doing in Art. By Helen M. Fiedler, Supervisor of Art in Public Schools. A Bulletin issued by the Board of Education, Cleveland, Ohio.

Some and Best Parts. Circular No. 190, Illinois, 1922. Issued by Francis G. Blair, Superintendent of Public Instruction, Springfield, Ill.

Preparation of Teachers of the Social Studies for the Secondary School. By Edgar Dawson. Bulletin No. 3, 1922. Issued by the U. S. Bureau of Education, Washington, D. C.

Salaries of Administrative Officers and Their Activities in School Systems of Cities of 25,000 Inhabitants or More. By Walter S. Deffenbaugh. Bulletin No. 30, 1921. Issued by the U. S. Bureau of Education, Washington, D. C.

Vocational Courses in the Los Angeles City High Schools. School Bulletin No. 41. A descriptive course of study of the vocational subjects taught in the junior and senior high schools.

Vocational Accounting Tests of General Mechanical Ability. By Julia L. Stranquist. Issued by C. H. Stetson Company, Chicago, Ill. Description and manual of directions for using the tests.

Training for Vocational Guidance. Report of the Committee on Training for the Vocational Guidance for Juveniles, National Vocational Guidance Association. Issued by the American Association of Social Workers, 130 East 22nd Street, New York.

Departments of Manual Training. This bulletin describes a course for the preparation of teachers for elementary schools and junior high schools at the State Normal School, Newark, New Jersey, for the year 1922-23.

Guiding Course in Hydraulic Machinery for Junior High Schools and Part-Time Schools. By Earl L. Beitel and J. H. Trybom. Bulletin No. 214, 1922. Issued by The State Board of Control for Vocational Education, Lansing, Michigan.

The Cost and Utilization of Power in Farm Work: Factors for Control. By H. R. Tolley and L. A. Reynolds. Bulletin No. 267. Issued by the U. S. Department of Agriculture, Washington, D. C.

Chimneys and Fireplaces. By A. M. Daniels. Farmers Bulletin No. 1230. Issued by the U. S. Department of Agriculture, Washington, D. C. This little pamphlet tells how to build chimneys and fireplaces.

Brief Against the Study of Latin and Greek. By Lamar T. Beman. Reprint from *The Study of Latin and Greek in The Handbook Series* by The H. W. Wilson Company, New York City.

The Conversation Schools of New Jersey, 1921. Issued by the Department of Public Instruction, Trenton, New Jersey.

"A very treasure chest of color"

So happily has the box of Dixon's Colored Pencils been described. For within each wooden casing is contained potential beauty—awaiting the touch which will release such tones and shades as best express your mood.

Strong, virile, primary colors and every delicate hue are there. And such is the quality of manufacture that, with Dixon's "Best", the colors seem to flow and blend on paper as readily as with tube or brush.

In every pencil you will find the velvety smoothness, the perfect balance and quick response to the lightest touch which every artist seeks.

*To art Supervisors
and Teachers:*

*Send name, position
and address for
sample set.*

DIXON
"BEST"
COLORED PENCILS

JOSEPH DIXON CRUCIBLE CO.
Pencil Dept. 18-J. Jersey City, N. J.



*—and they
won't break
easily!*

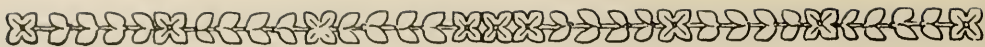

INDUSTRIAL EDUCATION IN THE HAWAIIAN ISLANDS

THE American Legion of the Hawaiian Islands has taken a special interest in the development of manual and industrial subjects in the public schools. A committee of Legion members with Frank E. Midkiff, Oahu, as chairman, has made a comprehensive study of the industrial needs of the islands, and has found that there is an insistent demand by the public in general for an expansion of industrial education.

As a consequence of this condition the committee has recommended that the American Legion, Department of Hawaii, create and foster a bill to extend and improve industrial education in the public schools. The following needs have been listed as those which require immediate attention.

(1) More emphasis on industrial education in the public schools. An increase in the time available for this subject is recommended as a remedy.

(2) More specific industrial and agricultural training of industrial teachers at the normal school. A larger faculty, more buildings, more equipment, and more grounds for the normal school, in addition to higher entrance requirements for this school, are suggested remedies for filling this need.

(3) Securing and retaining competent teachers of specialized subjects. A change in the system upon which salary schedules are based is recommended as a means of interesting well-qualified teachers.

(4) Improvement of teachers now in the field. Larger summer school appropriations, more general attendance, and more emphasis on industrial education in the summer school curriculum are the suggestions made for improving the teachers.

(5) Increased co-operation between educational and industrial interests of the communities. More emphasis should be given to prevocational education, Hawaiian agriculture, and part-time education.

(6) Adequate number of buildings for industrial work. Special appropriations for each island are recommended to fill this need.

(7) The establishment of territorial nautical school. The people of the islands are naturally adapted to nautical activities; the location warrants the establishment of such a school.

The committee is working in close connection with the industrial supervisors of the islands, the Y. M. C. A., and other agencies interested in the problem. Frank S. Pugh, who is the supervisor of the island of Kauai, is also a member of the Legion

committee. The additional supervisors are R. C. Bowman, Maui; John A. Perreida, Oahu; and Frederick A. Claws, Hawaii; Benj. O. Wist, principal of the Normal School; Kenneth G. Bryan, principal of the Territorial Trade School.

HOMEWORK AMONG CHICAGO INVALIDS

OPPORTUNITIES for a brighter outlook on life are being offered the crippled people of Chicago thru what is known as the Vocational Society for Shut-Ins. This society is a civic organization supported by membership-fees and donations. Its aim is to discover the incapacitated and shut-in people and to open to them the possibilities of purposeful, remunerative, and wherever possible, curative employment in their homes.

The society seeks to discover these people thru twenty or more existing agencies such as the Red Cross, United Charities, hospitals, Visiting Nurses Association, Y. W. C. A., etc., and also the news papers. A recent report shows that 160 active workers are now turning out salable products in the way of basketry, needlework, weaving, woodwork, certain types of office work, etc. The following paragraph from the report will suggest to the readers something of the activities of this society.

"A message comes from Mrs. A., for instance. The Vocational Director calls upon her and finds a woman of twenty-five, a victim of infantile paralysis, completely bed-ridden, although able to use her hands a little, and desperately in need of funds. Her case is made an individual one and studied from every angle. She is supplied with materials and taught to make salable articles.

"Her work is graded and priced according to its merit and the length of time involved in its production and in this manner Mrs. A. is taught the fundamentals of business. The finished article finds a ready market, when displayed at the Vocational Society for Shut-Ins' work room, 60 West Washington Street, or at the frequent sales held in the homes of the Society's friends and supporters. The first money Mrs. A. receives for her work changes her entire outlook on life. She is no longer a consumer only, a burden—she is a producer. This fact alone is of vital concern to society at large."

DELGADO TRADE SCHOOL PROSPEROUS

The Delgado Trade School, New Orleans, which has been open less than a year, already has more than 700 students enrolled, according to a recent report from the principal, E. G. Martin.

Frank Paxton Lumber Co.

Kansas City, Kansas

We carry the most complete stock of domestic and foreign woods suitable for Manual Training

Glue with "GLUEY"

IT STICKS TIGHT

Many Manual Training Departments now find greater satisfaction in using this clean, efficient, and very economical paste. Unlike hot glue, it is always ready to use and can be applied without any disagreeable muss.

Send 10 cents for a sample tube of our GLUEY No. 4.

THE COMMERCIAL PASTE CO.
COLUMBUS, OHIO

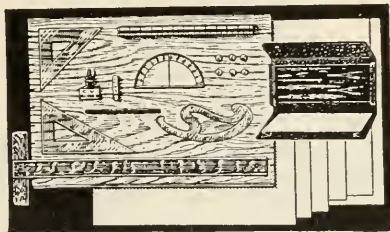

BEST QUALITY OF DRAWING INSTRUMENTS

Consistent with prices within reach of every student

COMPLETE LINE OF

T. Squares, Triangles, Scales,
Drawing Boards, Drawing Papers,
Pencils, Thumb Tacks, Etc.

Ask for Illustrations and Prices

THE OLD RELIABLE HOUSE
AMERICAN BLUE PRINT PAPER CO.
445 Plymouth Court, Chicago, Ill.

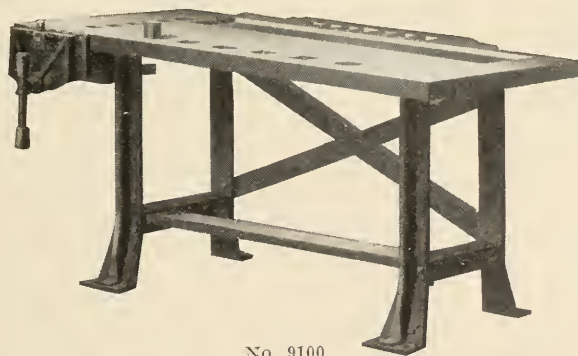

No. 9100

Built To Give Enduring Satisfaction—

Mr. Arthur Kinkade of the Board of Education of Decatur, Ill., writes of the laboratory equipment furnished by us for the new Roosevelt Junior High School:

"The cases, tables, desks and special pieces made by you are, in my judgment, very high quality, indeed. I believe I know cabinet work when I see it, having spent some ten years in the wood-working trade, and I want to say that you have an excellent product."

Consult us when you want standard or built-to-order manual training or laboratory equipment. Keep our catalog on file.

Wiese Laboratory Furniture Co.
ENGINEERS AND BUILDERS
Factory: Manitowoc, Wisconsin

WIESE LABORATORY FURNITURE

Ask for our new Catalog No. 28

SALES OFFICES:

14 E. Jackson Blvd., Chicago, Ill.
806 Observatory Bldg., Des Moines, Ia.
514 Kemper Bldg., Kansas City, Mo.
Louisville, Kentucky.
Otterbein, Indiana.
121 Chartres St., New Orleans, La.
244 Third Street, Portland, Ore.
1610 Bryan St., Dallas, Tex.
101 Market St., Harrisburg, Pa.
24-26 First Street, S., Minneapolis, Minn.
166 Waverly Place, New York, N. Y.
310 East Bridge St., Streator, Ill.



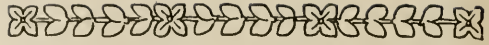

FIELD NOTES—(Continued)

NEW ENGLAND NEWS

THE Vocational Education Society of Boston met at Wentworth Institute on Saturday, April 1, by invitation of Prof. A. L. Williston, who was also largely instrumental in providing for a much-appreciated luncheon. This luncheon was enjoyed also by the Manual Arts Club of women teachers of manual training in Boston, which was a guest on this occasion.

After the luncheon Prof. Williston welcomed the two societies in his usual, appropriate manner and offered the facilities of Wentworth Institute freely both on this and similar future occasions.

Frank M. Leavitt, associate superintendent of schools, Pittsburgh, formerly director of manual arts in the Boston Schools and a former president of the Boston Manual Training Club, then referred in a happy vein to past experiences here, after which he gave a very interesting resume of vocational and related work in the Pittsburgh schools.

Elmer W. Greene, of the Institute, then furnished an interesting description of the new school of photo-engraving which is being conducted in this institute, and amplified his remarks with an exhibit of monochrome and color plates pertaining to this work.

EXHIBITIONS HELD

Wentworth Institute has recently held its eleventh annual exhibition of electrical work, plumbing, pattern making, machine shop practice, forging, foundry practice and core making, power plant work, applied science, drafting, mathematics, etc. The new departments with their fine problems in graphic arts, photo-engraving and linoleum block printing proved to be particular attractions on this occasion.

On March 27th, Franklin Union, of Boston, held an "open house and inspection night" which afforded ample opportunities for the examination of students' work. An interesting demonstration of wireless telephone was also given at various times during the evening's program.

EXPERTS ON VOCATIONAL GUIDANCE MEET

A MEETING of the New England Vocational Guidance Association was held at the Boston University, March 11. Among the speakers on the program were Miss Mary Anderson, director of the Women's Bureau, United States Department of Labor, Washington, D. C.; E. S. Riley, vocational counselor, Lawrence, Massachusetts; and Dr. Payson Smith, commissioner of education of Massachusetts. The speeches presented many phases of the problem of vocational guidance. The following is quoted from Dr. Smith's address:



Prang Tempera Colors—
the perfect medium for school
design work

SINCE design work has taken such an important place in school art courses, Prang Tempera Colors have come into wide use.

Made of the finest of materials, they give rich, velvety effects in intensely brilliant tones, and may be applied without danger of clouding or glazing.

Their popularity among art teachers and students alike is due largely to these things:

To their subtle differences in color tones;

To their capacity for remaining intimately mixed, both while in use and while standing unused from one day to another;

To their adaptability for use on paper, cardboard, wood, modeling clay and a variety of other surfaces;

To the fact that they will not crack nor mold nor mildew.

Made in the largest and most thoroughly equipped factories of their kind in the world, Prang Tempera Colors are products of an unsurpassed manufacturing skill. They may be obtained in opaque glass jars and in tubes, the full palette of colors giving all the elasticity needed for the finest work.

THE AMERICAN CRAYON COMPANY
ESTABLISHED 1835
SANDUSKY · OHIO · NEW YORK



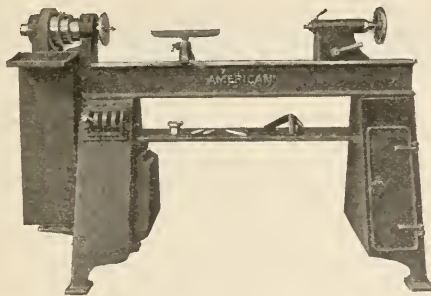

Manual Training Lathe with Motor
in Base—24" to 72" Centers

AMERICAN School Equipment

High Quality Machines
at Moderate Cost -

SAW BENCHES
JOINTERS
PLANERS
BAND SAWS
WOODWORKERS



AMERICAN SAW MILL MACHINERY CO.
142 Main St., Hackettstown, N. J.

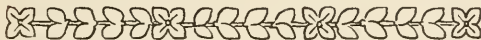

FIELD NOTES—(Continued)

THREE PROBLEMS OF EDUCATION

"There are three outstanding problems of education. One of these problems is the determination of our educational aims. It is of enormous importance in all our educational work, whether it be that implied in a single recitation, or in the laying down of a course of study, or in making a large program of education that we should know what it is we are after. In education, as in other things, and more in education I think than in other things, we have in a measure failed because we have not always been clear as to our aims. Every subject must be tested in the light of what it has to produce in the education of the individual and the welfare of the group.

Another thing which must call for much serious thought is the making of our educational systems more flexible so that the individual and his needs may be served. We must bear in mind that the large educational result that we are after, the large social aim that we achieve, is going to be reached finally thru the unit, the individual, rather than thru the group. Thus we are not going to improve citizenship except as we improve the citizen.

Hard-To-Get Materials

This is the Line you have
been looking for

Unusual Cabinet Hardware
Chest Trimmings
Upholstery Supplies
Cushions
Mirrors

Catalog to Instructors

Thurston Manual Training Supply Co.

Jobbers and Manufacturers
ANOKA, MINNESOTA



WE ARE GENERAL AGENTS FOR THE WORLD
FAMOUS GENUINE RICHTER

DRAWING INSTRUMENTS

They represent the highest standard in quality
and have no equal anywhere.

Write and give requirements.

*Complete circular showing sets and separate tools
mailed on request.*

U. S. BLUE PRINT PAPER CO.
CHICAGO, ILLINOIS

Two More 'Cass' Books

Published by Wiley

TECHNICAL MATHEMATICS

By Harry M. Keal

Head of Mathematics Department,
Cass Technical High School, Detroit.

Nancy S. Phelps

Grade Principal, Southeastern
High School, Detroit, and

Clarence J. Leonard

Instructor in Mathematics,
Cass Technical High School.

Volumes I and II Are Ready

Volume I represents the first three semesters' work, the equation being the main topic.

278 pages—478 by 7—148 figures, cloth.

Volume II takes up the work of the fourth and fifth semesters, developing the triangle and breaking the line between plane and solid geometry, covering the latter as far as spherical geometry.

271 pages—478 by 7, 307 figures, cloth.

Volume III will be published during the summer. Oblique triangulation, the geometry of the sphere, and the necessary practice in logarithms and the slide rule are given.

These books fit the student for engineering colleges, and the students who have been through this series have been uniformly successful in such college work.

Send for Vols. I and II—TODAY

WILEY FREE EXAMINATION COUPON

John Wiley & Sons, Inc.,

432 Fourth Avenue, New York City.

You may send me the following on 10 days' approval:

I agree to pay for the books or return them within 10 days of receipt.

.....

.....

Name

Address

If teacher, state school

If not teacher, give reference

M. T. M. 5-22

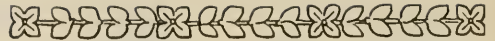

FIELD NOTES—(Continued)

"Moreover, organization in itself has no power to educate. It will be useful only as it may increase in one way or another the opportunity of the teacher to do better work. But we must not rely too much on organization for educational results. We are perhaps likely to forget the auto-cracy which comes from the false point of view that people must think alike and act alike. There may be something very cruel and restrictive in such an attitude, especially toward education. Progress has come, in the first place because some individual has thought in advance of others, and then that individual has won a minority to his way of thinking and that minority in time has won a majority. I am not so clear that we ought to talk one hundred per cent opinion. One hundred per cent opinion may in the long run to some extent stop progress. But I must not go into this in detail, altho it interests me exceedingly.

"The third problem is the problem of your immediate interest and that is the problem of adjustment—the problem of adjustment of these young people to the industrial, social, and political society of which they are to be a part. Both the individual and the group are best served when each unit is in the place where it fits best.

THE PROBLEM OF FINDING A VOCATION

"If you were to ask me what people are just now most entitled to sympathy, I should say it is a young man who is trying to find his work and trying to find out how he can get into that work. And older men are very likely not to understand. The fathers are rather out of patience with their sons and are likely to say, 'When I was that boy's age, I had some idea what I wanted to do.' They may have forgotten their own struggles while conditions have greatly changed. I have been told that in normal times there are in Greater Boston 25,000 young men between the ages of 17 and 21 who are drifting from place to place testing themselves out, trying to find the work for which they are best qualified and often misunderstood and condemned by the people in whose employ they are. And when they try to get into the door of industry they do not know how to open it, and when it is opened, the people they find inside are rather critical and disposed not to understand them. Your purpose, which is that of bringing together the world of education and the world that lies outside, is one that must be realized if we are going to help effectively the young men, and young women too, of this present time and thus serve the community. This very great problem of adjustment rests upon education."

—FRANCIS L. BAIN.

SYRACUSE



No drill better known—None does better work

The "Syracuse" is the original wood boring drill—known and used by mechanics "who know" since 1878. Made of special steel and so tempered that contact with nails, screws or metal won't injure it. The "Syracuse" is forged hot, the grain of the steel thus following the twist making a stronger drill than when milled. Teach your students to know good tools and how to use them.

SPECIFY SYRACUSE DRILLS IF YOU WANT THE BEST

Write today for descriptive booklet

SYRACUSE TWIST DRILL CO., Syracuse, N. Y.

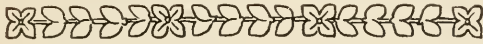

FIELD NOTES—(Continued)

MEETING OF THE NEW JERSEY VOCATIONAL AND ARTS ASSOCIATION

THE Sixth Annual Meeting of the New Jersey Vocational and Arts Association was held in Newark, New Jersey, March 24 and 25.

Miss Griselda Ellis, President of the Association, was not able to attend the meetings on account of illness. The Vice President, Arthur F. Hopper presided.

OPENING MEETING

The convention opened in the auditorium of the Central High School, Friday afternoon. Hugo B. Froehlich of Newark welcomed the convention to the city. The meeting which followed took the form of a supervisors' and teachers' conference with John J. Hatch of the New Jersey State Normal School, Newark, New Jersey, acting as Chairman. This conference took place at the request of the State Department of Education in order that certain problems which seem to require special effort in their solution might be placed before the supervisors and teachers of the state. The following program had been arranged by the State Department: "General Problems of Home Economics," by Mrs. Iris Pronty O'Leary; "Some Problems of

Sloyd Knives and Other

The right tools are recognized as essential in Manual Training. The several shapes and sizes of R. MURPHY Stay Sharp Knives made for this very purpose by makers of knives for special purposes for over 72 years, are alone in their class.



Manual Training Knives

The R. MURPHY Stay Sharp Manual Training, Sloyd, Wood Block, Stencil and Cardboard Knives are made of the very best English Tool Steel, with Closed Ferrules and Polished Wood or Rubberoid Handles, Riveted. Tempered by the famous R. MURPHY process since 1850.

**The Standard of Enduring Quality
R. MURPHY**

TRADE **STAY SHARP** MARK

**Sloyd and Manual Training Knives
"Made Sharp to Stay Sharp"**

R. MURPHY'S SONS CO., Ayer, Mass.

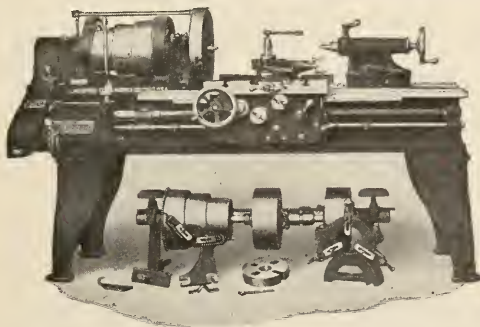

Champion Lathes

A quality engine lathe, accurate, convenient to operate and at a very attractive price to manual training and vocational schools.

Not the Cheapest, But One of the Best.

Made in four sizes: 13", 15", 17" and 19"

Champion Tool Works

Winton Place

Cincinnati, Ohio

SIMONDS SAWS

For better and smoother work Manual Training and Vocational Schools use Simonds Saws. They are the best, but they cost no more than some inferior saws.

Simonds
Manufacturing Co.

"The Saw Makers"
Fitchburg, Mass. Chicago, Ill.
5 Factories 12 Branches

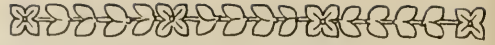

FIELD NOTES—(Continued)

Industrial Arts Education," by Robert A. Campbell; "Home Economics in Elementary Schools," by Miss Clara H. Kranter; "Training of Industrial Teachers," by J. Gould Spofford; "Some Problems in Industrial Education," by John J. McCarthy; and "Some Continuation-School Problems," by E. A. Reuther.

ANNUAL DINNER

Friday evening a "get-together dinner" was held with a large number in attendance. Besides splendid music provided by the Fawcett Industrial Arts School Orchestra every one enjoyed the addresses given by Dr. David B. Corson, superintendent of the Newark Schools and by Wesley O'Leary, assistant commissioner of education for New Jersey. Dr. Corson gave a message of inspiration to industrial-art teachers. He highly commended the marriage of the utilitarian to the idealistic as is provided for in the newer conception of industrial arts. In this address emphasis was placed upon the effect such subjects have in the development of honor, sincerity, and patriotism.

Mr. O'Leary discussed some of the most vital criticisms of vocational and industrial arts activities which are being heard today. These criticisms were not only brought out but suggestions as to greater efficiency were made and much of a practical nature was offered in Mr. O'Leary's address.

ROUND TABLE MEETINGS

On Saturday morning the convention assembled at 9:30 and after a short general meeting divided itself into sectional meetings. The following sections were provided: Prevocational and Manual Training; Household Arts; Girls Vocational Schools; Boys Vocational Schools; Vocational Academic Subjects; Sub-Normal Classes; Art; Agriculture and School Gardens; and Continuation Schools.

LUNCHEON

A "keep-together luncheon" was held Saturday afternoon at 1:00 o'clock.

The speakers at the luncheon were E. Allen Smith, Rotarian, who spoke on "Self Analysis" and Dr. Fred S. Shepherd who discussed the place of Industrial Arts in the school curriculum.

—ALLEN D. BACKUS,

A PSYCHOLOGICAL CORPORATION ORGANIZED

THE Psychological Corporation has been incorporated under the laws of the State of New York. The second article of its charter reads:

"The objects and powers of this corporation shall

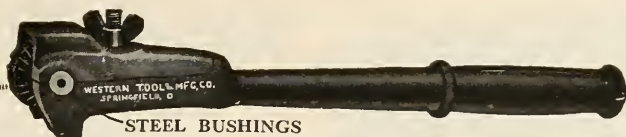

STEEL BUSHINGS

The "Champion" No. 1 Emery Wheel Dresser

Will Outlast a Dozen Cheap Dresser Handles

Handle is made of malleable iron, will not break. The spindle on which the cutters run is of steel. The bushings in which the spindle runs, are also of steel. Easily replaced.

"Tools of Quality" Ask for our Full Catalog

WESTERN TOOL AND MANUFACTURING CO. Springfield, Ohio

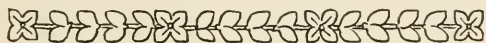

FIELD NOTES—(Continued)

be the advancement of psychology and the promotion of the useful application of psychology. It shall have power to enter into contracts for the execution of psychological work, to render expert services involving the application of psychology to educational, business, administrative and other problems, and to do all other things, not inconsistent with the law under which this corporation is organized, to advance psychology and to promote its useful application."

So far as is known, this is the first corporation organized under the provisions of the business-corporation laws of any state whose objects are the advancement of science and whose earnings must be devoted to scientific research. There are, of course membership and charitable corporations not for profit and exempt from taxation, but the Psychological Corporation proposes to earn by its services the money that it will use for psychological organization and research.

Dr. J. McKen Cattell, who is the president of the corporation, recently made the following statement:

"It is desirable that the general public shall have some means of learning what psychology can and

INTRODUCING THE C Y M A

Combination
COMPASS and
DIVIDER
with 2 Divider Points
—a Lead and a Pen

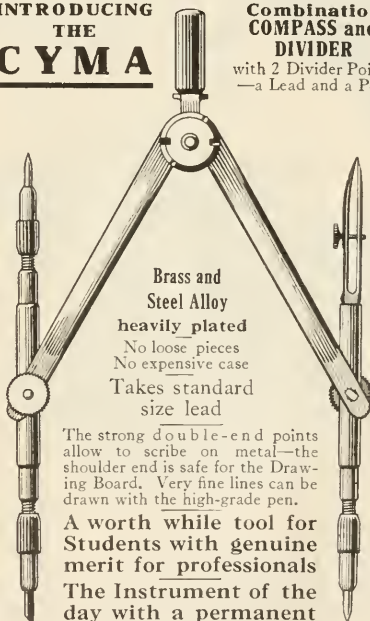

Brass and
Steel Alloy
heavily plated
No loose pieces
No expensive case
Takes standard
size lead

The strong double-end points allow to scribe on metal—the shoulder end is safe for the Drawing Board. Very fine lines can be drawn with the high-grade pen.

A worth while tool for
Students with genuine
merit for professionals
The Instrument of the
day with a permanent
future

Sample sent on 10 days approval
or upon receipt of \$1.00

EDGAR BOURQUIN

Manufacturer and Importer

1347 Main Street, Waltham, Mass.

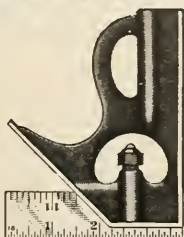

NEW LUFKIN

"UNIVERSAL"
TRY AND MITRE
SQUARES
FOR WOODWORKERS

HIGH GRADE YET POPULAR PRICED
ACCURATE—DURABLE—WELL DESIGNED

No. 65L—WITH LEVEL

No. 65—WITHOUT LEVEL

Made in 9-inch and
12-inch lengths

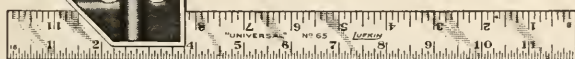

Distinct marking; movable yet secure head. Serves also as marking, height and depth gauge, level and plumb, and separate rule. If Unobtainable at Dealers Write Us Direct.

Send for Catalogue

THE LUFKIN RULE CO.

SAGINAW, MICH.
New York

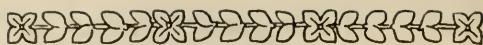

FIELD NOTES—(Continued)

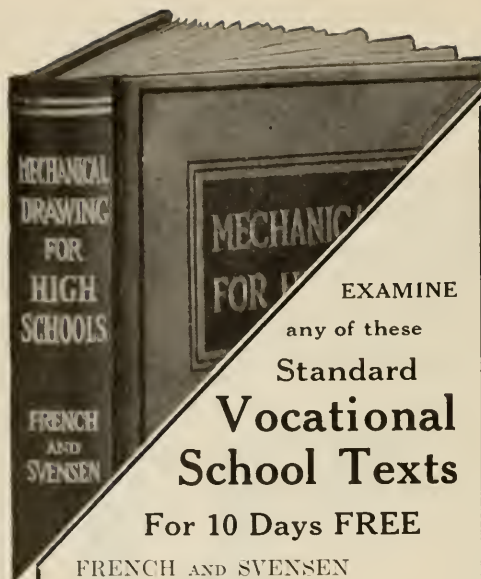

EXAMINE
any of these
Standard
Vocational
School Texts

For 10 Days FREE

- 1 FRENCH AND SVENSEN
Mechanical Drawing for High Schools.....\$1.50
The standard textbook—more widely used than all other books of its kind together. A real text, covering two years' work and providing an adequate supply of varied problems.
- 2 LONGFIELD
Sheet Metal Drafting.....\$2.25
A good textbook on fundamental principles.
- 3 FRENCH AND TURNBULL
Lessons in Lettering
Book I, Vertical, \$3.60 per doz.
Book II, Slant, \$3.60 per doz.—A series of practice books with text, examples and exercises.
- 4 STANLEY
Drawing Room Practice.....\$2.50
A complete textbook on machine shop drawing practice.

FREE EXAMINATION COUPON

McGRAW-HILL BOOK CO., Inc.
370 Seventh Ave., New York

You may send me on 10 days' approval

.....
.....

I agree to pay for the books or return them, postpaid, within 10 days of receipt.

Signed

School

Official Position.....

Address

.....

MTM 5-1-22

what it can not do, and who can and who can not do it. An organized group of psychologists, whose standing is recognized, can exert a useful influence at the present time."

The directors of the Psychological Corporation are: James R. Angell, Yale University; W. V. Bingham, Carnegie Institute of Technology; J. McKeen Cattell, The Psychological Corporation; Raymond Dodge, Wesleyan University; S. I. Franz, Government Hospital for the Insane; G. Stanley Hall, Clark University; H. L. Hollingworth, Barnard College, Columbia University; Charles H. Judd, University of Chicago; William McDougall, Harvard University; W. B. Pillsbury, University of Michigan; Walter Dill Scott, Northwestern University; C. E. Seachore, University of Iowa; Lewis M. Terman, Stanford University; Edward L. Thorndike, Teachers' College, Columbia University; E. B. Titchener, Cornell University; Howard C. Warren, Princeton University; Margaret Floy Washburn, Vassar College; John B. Watson, The J. Walter Thompson Company; R. S. Woodworth, Columbia University; R. M. Yerkes, National Research Council.

EASTERN ARTS ASSOCIATION
GOING TO PROVIDENCE

PROVIDENCE, Rhode Island, has been announced the meeting place for the fourteenth annual convention of the Eastern Arts Association in 1923. The dates for the meeting have not yet been determined. This year's convention, which has been pronounced the most successful ever had by the association, was held in Rochester, New York, April 6, 7, 8.

The officers for the coming year are as follows:

President: Frances H. Bachelier, Hartford Public High School, Hartford, Connecticut.

Vice-President: Edward H. Reuther, State Department of Education, Trenton, New Jersey.

Treasurer: A. H. Wentworth, New Haven Connecticut.

Secretary: Frank E. Mathewson, Jersey City, New Jersey.

Members of the Council (for Three Years.)

Augustine F. Rose, Rhode Island School of Design, Providence, Rhode Island.

Frederick W. Putnam, Technical High School, Providence, Rhode Island.

E. A. Cherry, Representing Commercial Exhibitors of the E. A. A., Stanley Rule and Level Company, New Britain, Connecticut.

CUSHIONS

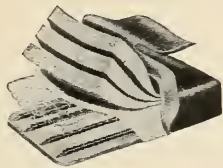

**Stuffed Cushions
Spring Cushions
Upholstery
Supplies**

*Write for Descriptive
Circular and Complete
Information for ordering*

Illinois Valley Awning and Tent Co.

Formerly Kunkle-Karl Co.

102 S. Washington St. Peoria, Ill.

"JORGENSEN" HAND SCREWS

Withstand the
abuse of inex-
perienced hands.

Steel Spindles
Steel Nuts
Hard Maple Jaws

**Adjustable
Clamp Co.**

216 N. Jefferson St., Chicago

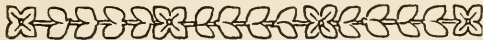

FIELD NOTES—(Continued)

SHORTAGE OF TEACHERS IN CHICAGO SCHOOLS

THE eligible lists of qualified teachers of special subjects in both the elementary and high schools have been practically exhausted. Examinations will be held for candidates for certificates to teach in the public schools of Chicago on June 26, 27, and 28th. Anyone interested may write to the Board of Examiners, 460 South State Street, Chicago, for a circular of information, and an application blank. A booklet of former questions will be furnished if 10c is enclosed.

Frequently teachers are assigned immediately after an examination. At other times they are obliged to wait some time before their names are reached on the list.

Candidates for elementary manual training, and printing certificates are required to show credentials covering high school graduation and two years of special training.

Candidates for limited certificates in High Schools for such subjects as mechanical drawing, machine shop, blacksmithing, foundry, woodworking, electrical construction, sheet metal, printing, and auto-

SAW TABLES

For Manual Training

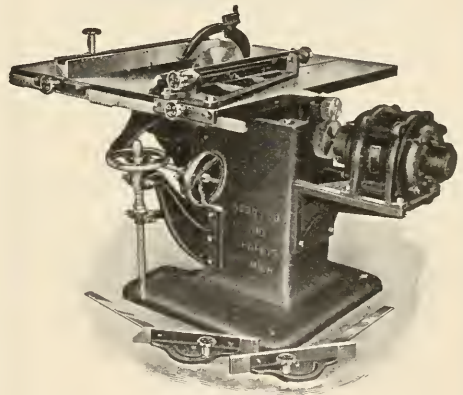

This cut shows our motor driven spiral gear saw table. No countshaft, no belts. Tilting or stationary tops. Write for circular and prices on our entire line. *Address*

ALEXANDER DODDS CO.

451-453 Monroe Ave., N. W.

GRAND RAPIDS, MICHIGAN, U. S. A.

In Gt. Britain: OLIVER MACHINERY Co., Manchester, Eng.

MAYDOLE HAMMERS

THE WORLD'S STANDARD

Highest Quality Steel Handled Hammers
Guaranteed First-Class in Every Respect

*Booklet of Useful Information
for each student on request.*

The David Maydole Hammer Co.

Norwich, N. Y., U. S. A.



TOOLS HARDWARE AND SUPPLIES

Is the title of our New
317 Page Catalog and
which is of interest to
every Manual and Voca-
tional Training Director.

When asking for Copy please
specify Catalog No. 239

**Hammacher
Schlemmer & Co.**

New York Since 1848

4th Ave. and 13th St.



FIELD NOTES—(Continued)

mechanics are required to have at least a high school education and three years of special training in their major subject.

A ten-year salary schedule is maintained in both the elementary and high schools; the range of the former being from \$1475.00 to \$2250.00, while the limited certificate high-school schedule ranges from \$1600.00 to \$3000.00.

EMPHASIZING THE PRACTICAL SIDE OF ART

SPECIAL emphasis will be given to industrial art at the thirteenth annual meeting of The American Federation of Arts which will convene at Washington on May 16 to 20. One full day's program will be devoted entirely to the discussion of various phases of art in relation to industry. The following topics are a few of those listed, the discussion of which will emphasize the practical side of art: "Industrial Art as a National Asset;" "Industrial Art as a Personal Responsibility;" "The Craftsman Today—His Relation to the Community;" "The Machine and Design—Quantity Production;" "Art and the Printing Press;" "Building Up the Local Society of Craftsmen."

There are now 277 affiliated chapters of The American Federation of Arts, representing forty states.

OILY RAG CAUSES FIRE IN SCHOOL

A fire which originated in lockers containing students' shop clothes recently broke out in the Boys' Trade School, Worcester, Massachusetts. Spontaneous combustion of oily rags or clothing is thought to be the origin of the blaze which did a damage estimated at about \$500.

Build Your Own PHONOGRAPH

Instructive—arouses pupils' enthusiasm—provides one of the best problems in cabinet making.

Let Your Pupils Build
Choraleon Phonographs

We furnish plans, blue prints, motors, tone arms, case material—in fact, everything required. Full instructions. Choraleon's have fine tone. Play any record. Ask for particulars.



CHORALEON PHONOGRAPH CO.
522-7th St., Elkhart, Ind.

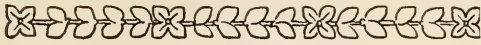

FIELD NOTES—(Continued)

ITEMS OF PROGRESS

WOMEN'S CLUBS INTERESTED IN TRADE SCHOOL

PLANS are being made in the state of Alabama to raise the sum of \$30,000 for the Alabama School of Trades at Ragland. The women's clubs thruout the state are working in connection with the exchange clubs of the various communities. It is expected that the full amount will be obtained within a short time.

BUILDERS' ASSOCIATION
STANDS FOR INDUSTRIAL SUBJECTS

In Portland, Oregon, where a proposal has been made to curtail school expenses in a certain district thru a reduction in the courses in drawing, shop work, and commercial studies, the Association of Building and Construction has presented resolutions opposing any reduction in these subjects. It has been pointed out that there is a great shortage of skilled workers of all building crafts and that boys need to be encouraged to take up such studies as may lead to these crafts.

HOUSTON EVENING SCHOOL PROGRAM

The curriculum of the evening schools of Houston, Texas, has been increased during the second semester. The courses now offered are drafting and cutting men's clothing, estimating for carpenters and builders, blue-print reading, electricity, how to burn fuel oil economically, mathematics for machinists, sheet-metal drafting and shop-practice, plumbing, roof framing, and oxy-acetylene welding.

PROGRESS OF YOUNGSTOWN INSTITUTE

Thirty-three years ago the beginning of the school which is now the Youngstown (Ohio) Institute of Technology was made in the Y. M. C. A. headquarters of that city. The school has grown constantly since that time and has now an enrollment of over 2,000 students. Of this number 1,600 are attending the evening schools in which a great variety of subjects are being taught. The name of

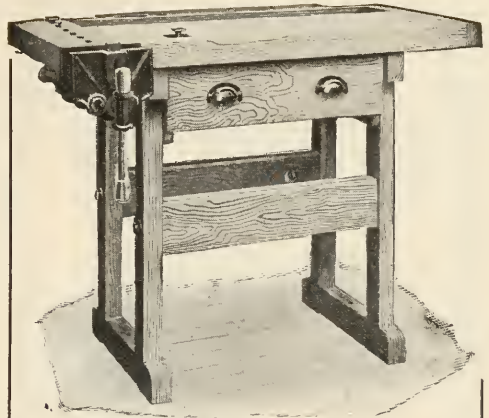

Manual Training Bench, No. 16

which is furnished with one Abernathy Rapid Acting Vise, and with one drawer.

Ask for our new Catalog No. 27

C. CHRISTIANSEN

BENCH MANUFACTURER

2814 W. 26th St. CHICAGO, ILL.

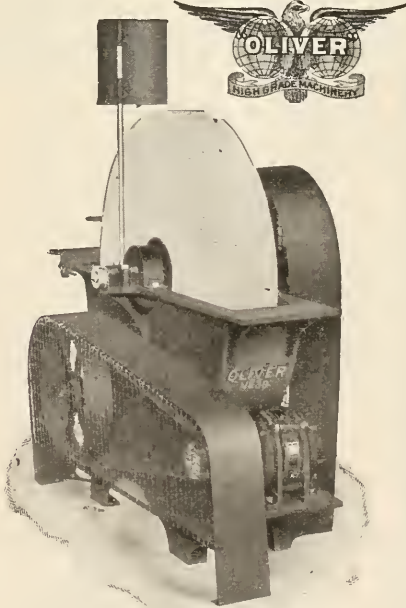

No. 39-C Motor Drive Grindstone
Have you a catalog of "Oliver" Quality?
Woodworking Machinery
OLIVER MACHINERY COMPANY
Grand Rapids, Mich., U. S. A.

L-U-M-B-E-R

We Specialize in
Manual Training Lumber

No order is too large or too small to receive our careful attention

John S. Benedict Lumber Co.
419 N. Halsted St. CHICAGO

STANLEY "EVERLASTING" CHISELS

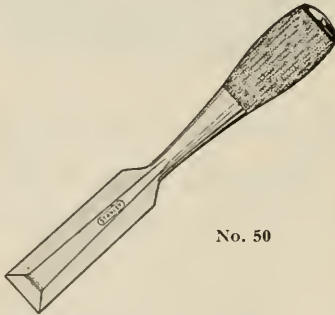

No. 50

Stanley "Everlasting" Chisels have made good with the carpenters—hence their value and popularity in the educational field.

They are made in two styles, with beveled and square edge. No. 50, shown above, is representative of the line.

Head, shank and blade are forged from one piece of tool steel, insuring strength, durability and providing for maximum efficiency.

Handle of selected hickory, well finished and fitted snugly into ferrule. Special patented construction prevents handle from splitting.

Write for Stanley Tool Catalog, 15E



The Stanley Rule & Level Plant

THE STANLEY WORKS

NEW BRITAIN, CONN.

New York Chicago San Francisco
Los Angeles Seattle

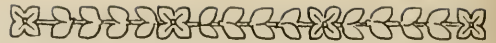

FIELD NOTES—(Continued)

the school has been changed a number of times to better express the scope of its services. In 1916 it was named the "Youngstown Association Schools." Last year, after further expansion of the program of the school, the name "Youngstown Institute of Technology" was adopted.

FIELD DAY AT HOUSTON, TEXAS

There is one day each spring for which the boys of Houston make great preparation. It is the day of the annual kite tournament. This tournament which is held under the auspices of the Department of Recreation and Community Service has come to be more than a day for the boys. It has developed into an event to which a great crowd of people, both young and old, gather, in order to observe and enjoy the skill and ingenuity of the boys as expressed in the construction and the flying of their kites.

This year the tournament was held on March 11. All kites entering the competition must be home made. Gold, silver, and bronze medals were awarded to the winners.

MERCHANT TAILORS BOOST TRADE SCHOOL

The New Orleans Merchant Tailors' Association at a recent meeting assigned themselves definitely to the task of backing the courses in tailoring which are now given at the Delgado Trades School. This is one of the few schools in the United States where tailoring of men's clothes is being taught.

BOYS HELP WOUNDED SOLDIERS

A class of boys in the George W. Morris School, Louisville, Kentucky, have been busy sawing out in the rough a large number of toys to be sent to the convalescent soldiers at the United States Marine hospital. This gives the soldiers an opportunity to turn out some useful work within the limits of their physical ability. Miss Elizabeth Green is the teacher of this aggressive group of boys.

NEW HIGH SCHOOL IN ATLANTIC CITY

Contract has been awarded for the erection of a new high school building in Atlantic City which is claimed to be one of the finest in the United States. The estimated cost of building and equipment is \$1,600,000. The building covers approximately 175 x 300 feet and is four stories high. It contains 140 recitation rooms and an auditorium having a seating capacity of 2,500. Generous provisions have been made for manual training shops, laboratories, boys' and girls' gymnasiums, and swimming pool.

TOOLS

For Manual Training Shops.
Send your inquiries to and get the especially
low prices quoted by

MONTGOMERY & CO. Inc.,
105 Fulton Street New York City

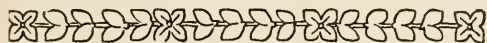

FIELD NOTES—(Continued)

CELEBRATED TWENTY-SEVENTH ANNIVERSARY

On March 11, the twenty-seventh anniversary of the founding of the Emmerich Manual Training High School of Indianapolis was celebrated. In connection with this celebration was announced the official opening of a new building containing a modern gymnasium, auditorium, kitchens, and a luncheon room which will seat 950 persons. This school, which was organized in 1905 by Chas. E. Emmerich, who was also its first principal, has long been one of the manual training high schools well known among students of education.

PARKS FOUR-IN-ONE

does anything in manual training
wood-working

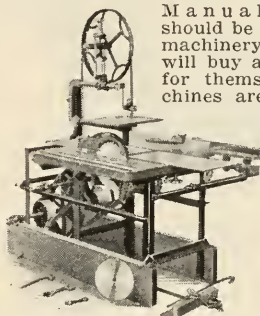

Manual Training Students should be trained on practical machinery — the type they will buy and use in business for themselves. Parks machines are practical, strong, durable, efficient. Practical carpenters, contractors, and cabinet-makers use and endorse them. Four-in-One complete—circular rip and cross-cut saw, band-saw, jointer and borer

\$225.00

Send for catalog.

The Parks Ball Bearing Machine Co.

1536-46 Knowlton St. Cincinnati, Ohio

Canadian Factory:
200 Notre Dame East, Montreal, Canada



Specialists in Manual Training Lumber

Maisey & Dion
Hardwoods
KILN DRIED AND AIR DRIED
OFFICE & YARDS 2349 TO 2423 So. LOOMIS ST.
TELEPHONES
CANAL 1830
CANAL 1831
CANAL 118

CHICAGO
THE
Great Central Market

The Boy Agriculturist, published by the St. Charles [Ill.] School for Boys, says:

"As an evidence that the printing trade is one of the best bets at this school we sent out several boys last month and all are at good jobs, and making from \$16.00 to \$35.00 per week."

The school printing plant gives valuable practical, educational knowledge that fits its students for positions inside printing industries as well as for other activities in life. A knowledge of the Printing Art lends dignity to the consideration of the problems of the world and helps to solve them.

We can equip any school with
print plants

BARNHART BROTHERS & SPINDLER

Chicago Washington Dallas Saint Louis
Kansas City Omaha Saint Paul Seattle

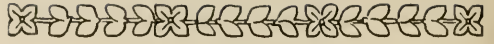

TRADE NOTES

A NEW SERIES OF TYPE FACES

THE interest in printing as a school subject is greater today than ever. Barnhart Brothers & Spindler, Chicago, announce the Cooper Series of type faces, a new Roman letter designed by Oswald Cooper, which lends itself to display advertising in a very satisfactory manner. Their "Advance Pocket Specimen" of this new type gives practical examples of its use for advertisements, job work, and book making. Ask them to send you a copy.

EXTENT OF WIESE LINE

A small circular just received from the Wiese Laboratory Furniture Company, Manitowoc, Wisconsin, gives one a very clear idea of the extent of their line. It includes standard or built-to-order furniture for manual training, home economics, physics, chemistry, biology, and agricultural departments of schools and colleges, in addition to furniture for hospitals and industrial plants. A complete catalog will be sent to any of our readers who request it.

A SUBSTITUTE FOR HOT GLUE

"Glue" Paste, as its name indicates, is characterized by adhesive qualities which have won for it a wide use in the schools. The manufacturers recommend it as a substitute for hot glue in the manual training shops. It is manufactured by The Commercial Paste Company, Columbus, Ohio. Full information concerning this product will be sent to those interested.

SPECIAL CATALOG FOR SHOP TEACHERS

Hammacher, Schlemmer & Company have just issued Catalog No. 565, which has been compiled principally for schools and small users of wood-working tools and supplies. However, it is sufficiently comprehensive to serve as an abridgment of their large complete catalog. It illustrates and describes all the hand tools used by woodworkers, metalworkers, machinists, auto mechanics and plumbers, and in addition it includes the large variety of supplies necessary for these forms of shopwork. Like all catalogs issued by this firm, it is well organized and fully illustrated. It is of convenient size, and an asset to every school shop. Readers of the *Manual Training Magazine* will be furnished a copy upon request.

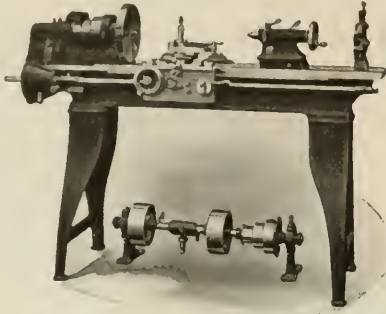

"Oliver" Engine Lathes

10-12-16-18-26-30-inch

"Oliver" Engine Lathes will appeal to you because they are well designed and built of best materials.

Accuracy and workmanship guaranteed. "Oliver" Lathes are simple yet built with various drives. Cone or Geared Head. Furnished with full tool room attachments if desired.

Oliver Machinery Co.

Grand Rapids, Mich., U. S. A.

SIMPLIFY GRINDING

With Mummert-Dixon Oilstone Grinders. Five wheels for almost every class of grinding. They accomplish the work quickly and accurately. With this machine your students can experience the pleasure of sharp tools.



The Modern Edge Tool Sharpening Machines.

The Standard for all Industrial Schools

Five Leading Features
Coarse Oilstone Wheel
Fine Oilstone Wheel
Emery Wheel
Grinder Cone
Leather Wheel

Furnished for motor drive or with counter-shaft
Send for full descriptive bulletin

MUMMERT-DIXON CO., Hanover, Pa.

A. R. VINNEDGE & CO.

SPECIALISTS IN

MANUAL TRAINING LUMBER

Write for our prices

2060 Clybourne Avenue
CHICAGO

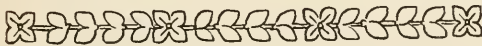

TRADE NOTES—(Continued)

LARGE HACK-SAW CHARTS

The Simonds Manufacturing Company of Fitchburg, Mass. and Chicago, Illinois, have recently put out a large hack-saw chart. This chart gives information relating to both hand sawing and power machine sawing. It also presents a condensed table showing the correct sizes of blades to use for cutting various metals and of various shapes. The table is arranged to apply to hand blades and machine blades of the several weights. It is of value where there is a machine shop department of considerable importance, especially where power hack-saw machines are in operation, as the chart gives some of the most useful and concise hints regarding the proper operation of blades in such a machine. The Simonds Manufacturing Co., will send one free to any supervisor or director who has charge of such a machine shop.

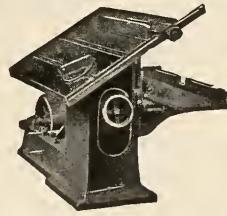

Crescent Wood Working Machines

are the tools your students will eventually use so give them the opportunity now of learning about this splendid line of wood working machinery.

Send today for our catalog of band saws, jointers, saw table, shapers, variety wood workers, planers, planers and matchers, cut off saws, disk grinders, borers, hollow chisel mortisers, Universal wood workers.

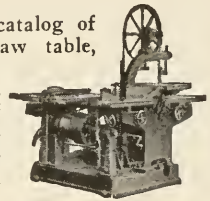

The Crescent Machine Co.

46 CHERRY ST. LEETONIA, OHIO

No More Loose Handles

Don't take chances with Hammers with ordinary Wedges when you can now secure the **UNCLE SAM BRAND** Hammers with the new **VAUGHAN'S EXPANSION WEDGE**.

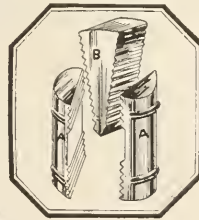

If the handle shows any tendency to become loose simply set the Wedge (B) a notch or two deeper between the pins (A) and a tight handle is assured.

UNCLE SAM HAMMERS are the only Hammers that have been approved by the **UNDERWRITERS' LABORATORIES** and each Hammer has the Underwriters' Label. It took 900 lbs. more pressure to pull the handle through the head with the **VAUGHAN'S EXPANSION WEDGE** than with the Ordinary Wedge. Uncle Sam Hammers are made in all patterns and sizes. Write for description booklet No. 10 which describes this line in detail.

VAUGHAN & BUSHNELL MFG. CO.

2114
Carroll
Ave.



Chicago,
U. S. A.

Give Your Pupils SHOP-WORK THAT PAYS Let the Boys Build Phonographs

Imagine the pride and joy of your pupils in building their own phonographs (equal in quality to high-priced standard machines) either to sell or take home as a source of lasting pleasure. Think how this project will add to your popularity as an instructor. Building phonographs is easy, by our methods, yet it demands precision and delicacy of workmanship, the very points always emphasized in shop practice.

Send 10c for fine illustrated catalog

and full information about our co-operative plan for manual training teachers. We plan the work for you. We supply blueprints, tone-arms, motors, case material and all accessories at lowest prices. Detailed instructions furnished. Materials best obtainable, fully guaranteed. Our machines play any make record. Write us TODAY.

HOOSIER MANUFACTURING & SUPPLY CO.
PHONOGRAPH SUPPLY DEPT.

315 Baldwin Block, Dept. A. Indianapolis, Ind.



CLASSIFIED ADVERTISEMENTS



Do you want to sell or want to buy some school shop supplies? Do you want to employ a teacher? Do you want a new position? Advertise your wants in these classified columns. Rate 20c a line, minimum \$1.00.

BASKETRY

BASKETRY MATERIALS. Reeds, raffia, wooden bases, chair cane, Indian ash, splints, cane webbing, wooden beads, braided straw, rush, willow, pine needles, books, tools, dyes. Catalogue and Directions, 15 cents. Louis Stoughton Drake, Inc., 34 Everett St., Allston, Station 34, Boston, Mass.

REED FOUNDATIONS AND SUPPLIES. Veneered tray bottoms, clear pine bottoms, lamp standards and fixtures, galvanized iron containers, finishing materials, etc. Send for catalogue. The Kessel and Nyhus Co., 910 Westminster St., St. Paul, Minn.

WOODWORKING MACHINERY

WE HAVE THE FOLLOWING USED WOOD AND METAL WORKING MACHINERY FOR SALE, all in very good condition. Four—"Oliver" under drive 12" speed wood lathe. One—Steploe Shaper 16" cut. Six—Double Down draft forges "Buffalo." Address—Faribault Asso. Schools, W. E. Peik, Supt.

ELECTRICAL PROJECTS

BUILD "PEPCO" ELECTRIC TOASTERS—A useful and attractive project. Buy the parts from the Practical Electrical Project Co., Highland Park, Illinois.

BLUE PRINTS

FREE CATALOG AND SAMPLE—Blue Prints of Agricultural, Furniture Making, Mechanical Drawing, Wood Turning, Forge Work, Pattern Making and Whittling Problems. Make your work more practical. Work from blue prints. Schenke Blue Print Co., 1034 Carney Blvd., Marinette, Wis.

GRANDFATHER'S CLOCK—Blue prints, finishing material and instructions. Also works, dial, weights and pendulum can be purchased from us at surprisingly low prices. Send for particulars of our attractive offer. Clock Company, 1666 Ruffner St., Philadelphia, Pa.

MANUAL TRAINING LUMBER

YOU CAN SAVE MONEY AND TIME by buying OAK SQUARES and ASH SQUARES in Clear lumber, one to two inches thick and from 15 to 40 inches long. We also specialize in Cedar Chest lumber, Philippine and other Mahoganies. FRANK PAXTON LUMBER CO., KANSAS CITY, KANSAS.

AMERICAN WALNUT LUMBER—We carry a stock of over two million feet of Walnut Lumber, consisting of all grades and thicknesses from 1/2" to 4". Due to this large stock we are always in position to supply dry lumber for Manual Training use. Send us your inquiries. Frank Purcell Walnut Lumber Company, 12th Street & Belt Line, Kansas City, Kansas.

AROMATIC TENN. RED CEDAR BOARDS. Small shipments a specialty. Write us for prices delivered at your railroad station. Earthman Lumber Co., Murfreesboro, Tenn.

MORGAN MANUAL TRAINING MATERIALS—A perfect system of dry kiln enables us to give you lumber thoroughly dry. Carrying in stock large quantities of different woods permits us to fill your orders with the best selections. Write, sending us a list of the materials you desire. We will quote you attractive prices. Morgan Company, Oshkosh, Wisconsin.

LUMBER—Maisey & Dion, 2349 to 2423 South Loomis St., Chicago, Illinois, carry in stock a large and diversified stock of MANUAL TRAINING LUMBER. Fifteen years' experience with schools enables us to fill such orders satisfactorily.

FURNITURE HARDWARE

FURNITURE HARDWARE AND UPHOLSTERY SUPPLIES for Manual Training. Drawer pulls, costumer hooks, wood knobs, box fittings, tea wagon wheels, electric cluster posts, cedar chest locks, handles, hinges, etc., mirrors, wood dowels, Seng bed equipment, Stanley Tools. Send for Catalog, Ohio Vocational Supply Co., Wapakoneta, O.

ELEMENTARY HANDWORK

TAWIDO LOOMS with four treadles weave from 12" to 20" widths. Desk and Table Looms, 6" to 12". Tapestry loom 34". Shuttles, Yarnwinders, Warp Frames. Instruction in pattern weaving and tapestries. Elna M. De Neergaard, Tawido Looms Studio, 23 Union Square West, New York, N. Y.

EVERYTHING FOR ELEMENTARY HANDWORK—Also for basketry, weaving, bookbinding and chair caning. Mounting boards, Waldcraft dyes, crayons, burlap, scissors, punch and eye sets. Thomas Charles Co., 2249 Calumet Ave., Chicago.

UPHOLSTERY MATERIALS

CUSHIONS—You know your cushions will be made right when furnished by the Grand Rapids Cushion Company. Write for estimates on cushions and all kinds of upholstery supplies. Grand Rapids Cushion Company, Grand Rapids, Michigan.

CUSHIONS, APRONS, UPHOLSTERING SUPPLIES. If you make your own cushions we can supply the materials at reasonable prices. If you want complete cushions, we know how to make them, and our prices will interest you. Illinois Valley Awning & Tent Co., 102 S. Washington St., Peoria, Ill.

SCHOOL SHOP SUPPLIES

SODERING SUPPLIES, including the famous Allen Non-Acid Sodering Fluxes—in stick, paste, salts and liquid form; handy soder sets, sodering tools, aluminum soder and flux. As pioneers in the development of fluxes that far surpass muriatic acid, in every way, and as the original exponents of non-acid fluxes, the House of Allen has for 25 years maintained a position of leadership in the Arts and Crafts concerned with sodering. Send for our Bulletins L. B. Allen Co. Inc., 4584 N. Lincoln St., Chicago, Ill.

ANNOUNCEMENTS

IT IS NOW POSSIBLE for you to secure the parts necessary to build electric toasters. Write today for circular and price list to the Practical Electrical Projects Co., Highland Park, Illinois.

SEMI-PRECIOUS STONES

SEMI-PRECIOUS STONES. Large stock of Lapis, Moss Agates, Jaspers, Turquoise, Quartz Amethyst, California Jade, Amazonite, Chalcedony, Abalone Pearl Opals, Abalone Blister Pearls, and many other stones faceted and cabochon always on hand. Special sizes cut to order. Unsurpassed facilities. Memorandum assortments for selection gladly sent to instructors who write us on their letterhead. The Gift Crafters, School Arts Department, Tujunga, California.



BOOK NOTES

A NEW edition of *Carpentry* by Professor Ira S. Griffith of the University of Wisconsin has just been completed. A few of the pages in Chapter IV have been revised and now include the important addition of a purely graphic solution for problems of roof framing which has recently been worked out by this author. For certain problems, such as uneven pitches and octagon roofs, such a solution has decided advantages.

An illustrated method of laying out curvilinear hips and valleys, and a number of drawings showing standard methods of framing various dormers are other additional features which will make this edition of *Carpentry* of increased value.

HERE are some of the comments on *School Shop Installation and Maintenance* by Greene that have come from state supervisors of industrial education:—

"There is great need for such a book at this time."

"I feel that this book will render a distinct service to industrial arts teachers in the field. Mr. Greene is to be congratulated upon the very practical way in which he has organized the material. I am very sure that it will be a valuable reference book for all teachers."

"There is no doubt that there is need in the teaching profession of just such a book as *School Shop Installation and Maintenance*, as problems of equipping and maintaining school shops are at the root of successful accomplishment on the part of pupils and teachers alike. The book should have a place in the library of all teachers and supervisors of industrial education, and it might well be used as a text in certain courses in the industrial teacher-training institutions."

"I believe that it will be of greatest use to shop teachers as a handbook, and to teachers of vocational teacher-training classes. The chapters on babbitting and belting appeal particularly to the teachers of vocational agriculture for application in farm machinery."

"The little volume should prove of great help to teachers and supervisors of vocational and manual training work. You are rendering a great service to the profession in bringing forth books of this character."

"He has contributed a valuable work, and I shall take pains to bring it to the attention of our teachers in both the continuation and industrial schools."

"We shall take pleasure in commending this work to teachers of trade subjects in the state. It will

serve in all cases as an interesting reference and in many cases as an auxiliary text in trade courses."

THE April number of *Normal Instructor and Primary Plans* contained this review of *Practical Electricity for Beginners* by Willoughby:

"Nowadays, when electricity has become commonplace in small villages as well as in cities, and is even proving its usefulness on the farm, the average householder will find it desirable to be acquainted with the elementary principles, a knowledge of which is required in making minor repairs. Then, of course, there are boys in every community who have a bent toward things scientific and who are especially fascinated by electricity. To either the adult or the boy this text will prove useful in promoting familiarity with such facts as the beginner may be able to grasp."

THE Australian magazine *Life*, published in Melbourne, has reviewed Klenke's *Art and Education in Wood-Turning* as follows:

"The Manual Arts Press, of Peoria, Illinois, specializes in the publishing of textbooks for teachers—compact both in size and style, finely printed and excellently illustrated. The last one noted was on forge work for the farmer. The latest is *Art and Education in Wood-Turning*, by W. W. Klenke. Altho there are several works on this subject now available, this volume pays special attention to the art side of wood-turning. Mr. Klenke is a successful teacher, and his book meets all requirements as a text and manual, giving ample information in a thoroly satisfactory form regarding wood-turning technic. Any amateur and most professionals will find something of value in this little book, which is published in the States at 'one dollar forty.'"

CRITICS who see school shopwork from the art standpoint often deplore the fact that so much furniture that is made by students is not good in design. They are offended at many of the amateur efforts at designing. And they think that Mission furniture is crude and heavy. They say, "Why not have the pupils reproduce the period furniture of our forefathers? Then, when the work is done, they will have something worth keeping." It is just this viewpoint that has called forth the new book by Frederick J. Bryant, *Working Drawings of Colonial Furniture*. This book is just ready for distribution by The Manual Arts Press. It ought to be of real service to many teachers.

Kewaunee

MANUAL TRAINING FURNITURE

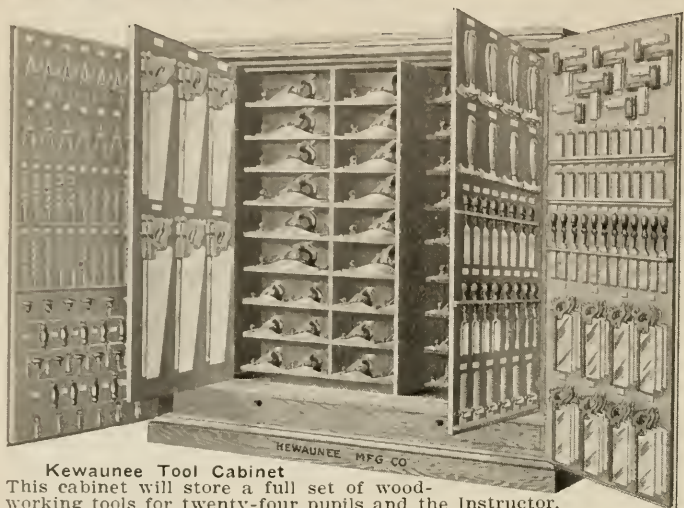

Kewaunee Tool Cabinet

This cabinet will store a full set of wood-working tools for twenty-four pupils and the Instructor. Each space and hook is numbered, and all tools are readily accessible.

BRANCH OFFICES:

Chicago
Houston
Omaha
Minneapolis

Little Rock
Spokane
Baton Rouge
Toronto, Can.

Jackson, Miss.
Columbus
Denver
Kansas City

Oklahoma City
San Francisco
Phoenix
Greensboro, N. C.

Kewaunee Mfg. Co.
LABORATORY FURNITURE EXPERTS

New York Office, 70 Fifth Avenue
111 Lincoln St., Kewaunee, Wis.

In design, material and craftsmanship, Kewaunee Manual Training Furniture conforms to the very high standard of quality exemplified by all other Kewaunee Furniture.

W. A. Brandenburg, President of the State Manual Training Normal School, Pittsburg, Kan., wrote:

"I take pleasure in stating that the Kewaunee school furniture has been used in city schools and in the State Normal College where I have had charge of work for the past fifteen years. I have a high opinion of the quality and practical value of Kewaunee school furniture. I have used it in every department in educational work and have never been disappointed, except with probably one piece, and this disappointment was made good by the company."

Ask for a free copy of the Kewaunee Book. Address all inquiries to the factory at Kewaunee.

The best is none too good for the boys—

Specify GREENLEE BITS AND CHISELS



No. 12 EXTENSION LIP AUGER BIT



No. 230 SOCKET FIRMER CHISEL

The Greenlee Bits are accurate in size with well formed cutting edges and spurs.

Chisels are light weight, tempered to give strength and toughness to withstand bending strains.

Both Bits and Chisels are highly finished and are sharpened ready for use.

They are quality tools and are guaranteed against all imperfections.

A Complete line of both Tang and Socket Chisels in various lengths, also Auger Bits, Car Bits, etc., with different forms of twist and types of cutting edges.

Ask for our complete catalog.

GREENLEE BROS. & CO.

Rockford, Illinois.



“Oliver” Variety Saw Benches

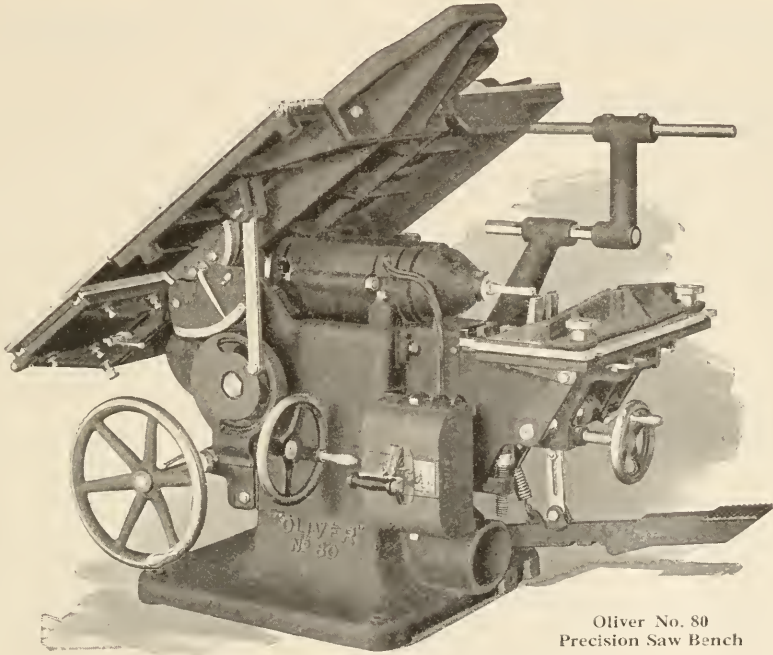

Oliver No. 80
Precision Saw Bench

“Oliver” Variety Saw Benches are built in several distinct types and sizes, each having various belt or motor drives applicable. Equipment and attachments to suit varying requirements supplied.

The No. 80 Motor-Arbor Saw Bench illustrated is the “last word” in saw bench design and construction. It is built with or without mortising and boring attachment, with plain or patent ball-bearing sliding table section.

Full details upon request.

Oliver Machinery Co.

Grand Rapids, Mich., U. S. A.

THIS MAGAZINE

WILL BE ENLARGED WILL BE ENRICHED
WILL HAVE A NEW NAME

BEGINNING WITH THE NEXT NUMBER

Hereafter the page size of this Magazine will be 9x12 inches and its name will be *Industrial Education Magazine*.

During the past twenty-three years it has rendered a special professional service to teachers and supervisors of school shopwork and mechanical drawing by reflecting the best thought on manual and industrial education and by publishing practical details of projects, courses of instruction and methods of teaching. With a better organization and increased facilities it will render the same type of service in the future, but better and on a broader basis. The new plan will make it possible for the Magazine to be of specific help to teachers engaged in the newer lines of shop teaching, whether in schools for vocational or general education.

The staff of editors will be strengthened by the addition of Lewis Gustafson, superintendent of the David Ranken, Jr. School of Mechanical Trades, St. Louis. During the past fifteen years Mr. Gustafson has been building up one of the very strongest trade schools in the United States and, during that time, has been a frequent contributor to the literature of industrial education. He is a graduate of Lewis Institute, and the University of Chicago and before he went to the David Ranken School he was an assistant professor at Lewis Institute. His editorial writings are sure to be a valuable contribution to the Magazine.

A notable feature of the new volume will be a series of studies of men in the profession, written by Arthur Dean. This will be in addition to Mr. Dean's regular contribution of "A Point of View." These studies will give facts now known to only a few persons, but which ought to be known to many. They will reveal some of the difficulties that have been overcome in this field and how; they will make it clear why some men stand high in the estimation of their co-workers. These articles will be an inspiration to the younger men in the profession; they will help to develop professional spirit. And surely, no one is as well qualified to do this as is Mr. Dean.

Among other articles for early publication are:

"The Place of the Industrial Arts in Elementary Schools," by Dr. F. G. Bonser of Teachers College, Columbia University.

"The Problem of Vocational Guidance in Correspondence Schools," by James McKinney, Educational Director, American School of Correspondence.

"A Study in the Correlation of General Intelligence and Progress in Learning Machine Shop Work," by Verne A. Bird, Director of Vocational Education, Utica, New York.

"A Course of Study in Shoe Repairing," by Harry E. Wood, Director of Manual Training, Indianapolis, Ind.

The most distinctive feature of the Magazine in the new form will be a group of departments which will give each month to the special teachers of the newer lines of shopwork just what some of them have been wanting—*more practical suggestions concerning projects, organization of subject-matter, equipments and methods of teaching.*

Among those who will contribute to these departments are:

Printing

- L. S. Hawkins, United Typothetae of America, Chicago.
E. E. Sheldon, The Lakeside Press, Chicago.
Ralph W. Polk, Robidoux Polytechnic School, St. Joseph, Missouri.
Katharine M. Stilwell, University of Chicago.
Lucy Matthews, Bowen High School, Chicago.

Electrical Work

- George A. Willoughby, Arthur Hill Trade School, Saginaw, Mich.
J. B. Scott, Hackensack, New Jersey.
W. F. Perry, Lyceum Hall Prevocational School, Boston.
F. G. Becker, Washington School, Cincinnati.
H. T. Thomson, Vocational School, Hammond, Ind.

Metalworking

- Edward Berg, Washington High School, Milwaukee.
Jacob Rindsberg, Rothenberg School, Cincinnati.
E. D. Soderstrom, A. & M. College, Stillwater, Oklahoma.
John Bowman, Jefferson, Jr., High School, Rochester, New York.

Mechanical Drawing

- William R. Reese, David Ranken School of Mechanical Trades, St. Louis.
Alfred W. Duwelius, Chairman of Committee on Mechanical Drawing Course, Cincinnati.
W. W. Sturtevant, South High School, Minneapolis.
Franklin G. Elwood, Instructor in Architectural Drawing, Mooseheart, Illinois.

Auto Mechanics

- Arthur Nelson, David Ranken, Jr., School of Mechanical Trades, St. Louis.

Auto Mechanics

- J. C. Wright, Director, Federal Board for Vocational Education, Washington, D. C.
D. R. Hoover, High School, Ann Arbor, Michigan.
Ray F. Kuns, Principal of Automotive Trade School, Cincinnati.
M. McElhiney, Emerson School, Gary, Indiana.

Farm Mechanics

- E. W. Lehmann, University of Illinois, Urbana.
Sherman Dickinson, University of Minnesota.
F. E. Armstrong, University of Idaho.
A. E. Brandt, Oregon Agricultural College.
V. A. Cory, Director of Industrial Training, Fairmount, Minnesota.
Mack M. Jones, University of Missouri.

Woodworking

- Victor J. Smith, Sul Ross State Normal College, Alpine, Texas.
E. H. Smith, Carnegie Institute of Technology, Pittsburgh.
Kenneth R. La Voy, High School, Hudson, N. Y.
E. C. Powell, High School, Massillon, O.
DeWitt Hunt, A. & M. College, Stillwater, Oklahoma.
J. I. Sowers, Vocational Director, Vincennes, Indiana.
Lee M. Klinefelter, Maury High School, Norfolk, Virginia.

Plans and Equipments

- J. H. Trybom, Department of Industrial and Manual Arts, Detroit.
Elmer W. Christy, Supervisor of Industrial Arts, Cincinnati.
W. R. Bussewitz, Supt. of Public Schools, Horicon, Wisconsin.
J. Douglas Wilson, Junior College, Riverside, California.

As in the past, the Magazine will contain news items from its special correspondents in different parts of the country, as well as trade notes, book notes, and brief reviews of current publications.

How to File a Saw

A Lesson in Outline

The only equipment necessary for filing saws consists of a clamp and files. To give the best working position, the top of the clamp should be on line with the operator's elbows.

Filing Cross-Cut Saws

The filer stands to the left of the clamp and at the point of the saw. He holds the file in the gullet of the first tooth and at a right angle to the side of the blade. Then, turning the point of file about 45 degrees toward the handle of the saw, he works in that direction against the front or the cutting-edges of those teeth set toward him (every other one).

After every alternate tooth has been filed to a uniform angle and bevel, the saw is reversed in the clamp. He proceeds to file the alternate teeth on this side, again beginning with the

first tooth set towards him at the point of the saw.

It is essential that the filer place the edge of the file well into the gullet between the teeth, letting the sides of the file find their own bearing against the front and the back of the teeth. The angle of the file thereby becomes the same as that of the teeth and the original shape is maintained.

To determine the correct position in which to hold the file, select a tooth of correct shape in the saw (there are almost always some unused teeth near the handle-end) and fit the file into the gullet. Such teeth will also serve as a guide for shape and bevel.

Filing Rip Saws

A rip saw has its cutting edge at right angles to the fibre of the wood. Consequently, the rip saw should be filed straight across.

File every alternate tooth one side, then turn the saw and, from the op-

posite side file the remaining teeth.

With the exception that rip teeth are filed straight across, the process of setting and filing a hand saw for ripping, is exactly like that of filing a hand saw for cross-cutting.

This outline gives only a few of the important points in filing a saw. The Disston "Saw, Tool and File Book" contains complete information, not only on filing saws, but on the general care and use of saws, tools and files. Write to Department M, and a copy will be sent you without charge.

Henry Disston & Sons, Inc.

Philadelphia, U. S. A.

The July issue of the Manual Training Magazine will explain "Why we give away books."

MANUAL TRAINING MAGAZINE

EDITORS CHARLES A. BENNETT, Peoria, Illinois.

WILLIAM T. BAWDEN, Assistant to Commissioner of Education Washington, D. C.

ASSOCIATE ARTHUR D. DEAN, Professor of Vocational Education, Teachers College, New York City.

EDITORS: FRANK M. LEAVITT, Associate Superintendent Public Schools, Pittsburgh, Pa.

WILLIAM E. ROBERTS, Supervisor of Manual Training, Public Schools, Cleveland, Ohio.

Business Manager: L. L. SIMPSON.

Published monthly by The Manual Arts Press, 237 N. Monroe St., Peoria, Illinois.

Subscription Price, \$1.50; Canada, \$1.80; Foreign, \$2.00. Single Copies, 25 cents; Foreign, 30 cents.

Subscriptions, remittances and manuscripts should be sent to THE MANUAL ARTS PRESS, Peoria, Illinois.

CONTENTS

NEW YORK CITY TEXTILE HIGH SCHOOL.....	<i>W. H. Dooley</i>	407
THE PRESENT STATUS OF INDUSTRIAL ARTS EDUCATION IN OUR ELEMENTARY SCHOOLS, III.....	<i>A. H. Edgerton</i>	413
THE WESTERN ARTS ASSOCIATION.....	<i>Emanuel E. Ericson</i>	422
PHOTOGRAPHS FROM EVERYWHERE.....		426
EDITORIAL REVIEW FOR THE MONTH.....		427
Death of William Hawley Smith—Another Point of View—The Continuation School —Professor MacDonald to go to the Ohio State University.		
A POINT OF VIEW.....	<i>Arthur Dean</i>	430
The Rochester Convention and the Rochester Schools.		
WASHINGTON CORRESPONDENCE.....	<i>William T. Bawden</i>	433
Army Training Plans—Important Changes in Personnel.		
PROJECTS, PROBLEMS AND NOTES.....		436
Examination in Forge Practice—Rocking Duck—Making Cheap Ornamental Hinges —Novelty Windmill and Weather Vane.		
CURRENT PUBLICATIONS.....		440
FIELD NOTES.....		VI
Pennsylvania and New Jersey—Industrial Work in New Orleans—Boys Operate Model School—California Field Notes—Around New York—Minnesota Notes— Printing Teachers in Session—Farm Shop Exhibits in Georgia—Requirements for Manual Training Certificates in Oklahoma—Twenty-fifth Year of Bradley Institute —Summer Conference at Dunwoody Institute.		
TRADE NOTES.....		XXVIII
BOOK NOTES.....		XLI

This Magazine is kept for sale at McClurg's in Chicago, and Brentano's in New York.

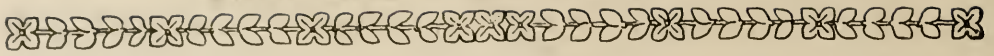

FIELD NOTES

PENNSYLVANIA AND NEW JERSEY

MEETING EDUCATIONAL ASSOCIATION OF
WESTERN PENNSYLVANIA

THE spring meeting of the Educational Association of Western Pennsylvania was held in the Schenley High School at Pittsburgh. There was an unusually large attendance in the Industrial Arts Section and the program was exceptionally rich.

L. H. Dennis, director of vocational education in Pennsylvania, gave an address on what is being done in this state in vocational education. This address was illustrated by a number of charts.

Edward T. Franks, of Owensboro, Kentucky, member of the Federal Board for Vocational Education, delivered an address on the crying need for a more intensive training of the farmers of tomorrow.

"Only by an intensive program of vocational training of the farmers of tomorrow can we avert a serious agricultural retrogression in the coming generation," declared Mr. Franks, who described the results now being achieved along vocational lines by the operation of the Federal Smith-Hughes act.

Mr. Franks explained the program of Vocational Education which the Federal Board in conjunction with the states is now promoting.

"At the time of the passage of the Vocational Education Act in 1917, the evidence at the Congressional hearings indicated that only one per cent of those engaged in agriculture were technically trained. Now agricultural instruction is being made available to all the children of the farms thru the public schools. It is recapturing their interest in agriculture as a dignified profession. And if it does not have the effect of completely stemming the exodus to the cities, it is increasing the productivity of those who remain. It is teaching them how to make two blades to grow where before there grew but one."

The speaker referred to the national movement for the conservation of national resources, and made the following statement: "Conservation of national resources is one of our greatest national problems, but the supreme problem of all is the loss of man-power which we are suffering from the working of unskilled and untrained labor."

A description of the work of vocational training which is now being conducted by the Board and the states among trade and industrial workers was also given.

"Vocational education is an inexorable economic necessity if our industries are to stand the test of international competition," declared Mr. Franks. This follows from our wage-rates. When it is realized that an ounce of gold buys only 17.22 hours of labor in America, as against 50.16 hours in Great Britain, 95.5 hours in Japan, 117.31 hours in France and 201.55 hours in Germany, it will be apparent how great is the margin which we must make up by superior efficiency. To give only one illustration: Thermos bottles which are made in Germany at a production cost of only nine and one half cents, cost to produce in the United States, \$1.013. Only vocational education with its result of a more skillful and productive body of industrial workers can overcome such an economic handicap."

Vocational education means a greater income to skilled labor, Mr. Franks declared, and he instanced the fact that an increase of even ten cents per day in labor wages owing to vocational skill, applied to the 41,609,192 people engaged in gainful pursuits would mean an increase of \$4,161,919. in the nation's daily pay-roll, and a resultant economic betterment thruout our entire system.

He appealed to his hearers to give their full cooperation to the efforts of the Federal and State Boards along such vocational lines. Under the Vocational Educational Act, Congress has this year appropriated a grant of \$4,120,833 to be apportioned among the states by the Federal Board for Vocational Education to support vocational education work in the public-school systems. These grants are allowed the states on condition that each state or local education board expend an equal amount upon vocational schools.

At the close of the year ending June 30, 1921, the number of Federal aided vocational schools in Pennsylvania numbered 406 with a total enrollment of 52,815 vocational pupils.

SCHOOL CRAFTS CLUB VISITS PAINT FACTORY

The regular April meeting of the School Crafts Club of New York scheduled to be held April 22, 1922 was given over to an inspection of the Sherwin-Williams Company paint factory in Newark, New Jersey. This company is the largest manufacturer of paints, varnishes, stains, and colors for the printing trade in the world and this trip provided an exceptional opportunity for the members to see the inside of the making of these materials so commonly used.

The Sherwin-Williams Company not only opened their entire plant to the club but also provided



Bird House Building Contest, Jones School, Chicago—Photo by Int. Film Service.

Minds and Blades of Lifelong Keeness

The imagination and creative ability of this boy—like that of many others in Manual Training Classes—is stimulated by building from his own designs. Here he is taking part in the bird-house competition of the American Forestry Association.

What an inspiring impulse is given to the designer who is able to carry out his ideas with tools of the Quality that Helps “the Young Idea” to Win!



FOR MANUAL TRAINING

have been long recognized as “the standard of enduring quality.”

The Sloyd Knife shown in the picture is highly appreciated by Manual Training Instructors and Pupils. So are the R. MURPHY Stay Sharp Manual Training Knives, Wood Block Knives, Stencil and Cardboard Knives. So are the R. MURPHY Stay Sharp Shoe Knives and many others of the R. MURPHY Knives used by expert craftsmen since 1850.

Write for full information to Manual Training Department.

ROBERT MURPHY'S SONS CO.

Ayer, Mass.





FIELD NOTES—(Continued)

guides who intelligently explained the various processes of manufacture.

FAWCETT SCHOOL OF INDUSTRIAL ARTS
EXHIBITS WORK

The Fawcett School of Industrial Arts, Newark, New Jersey held its annual exhibition April 26-28, 1922. It was evident from the students work which was on display that a very high standard is being maintained in this school.

Forty-three students of the Fawcett School were graduated the evening of April 25. These graduation exercises marked the fortieth anniversary of the institution.

Hugo B. Froehlich is principal of the school.

SCHOOLMEN'S WEEK, UNIVERSITY OF PENNSYLVANIA

The Ninth Annual Meeting of Schoolmen's Week was held at the University of Pennsylvania April 20-22, 1922. The attendance broke all previous records.

A joint meeting of the Metropolitan Arts Association of Philadelphia and of the Industrial Arts and Vocational Education section of Schoolmen's Week was held April 20. This meeting was well attended and the following program was presented: "Organization of the Course of Study in woodwork for the Intermediate Grades," A. Adele Rudolph, Supervisor of Industrial Arts, Philadelphia; "Recent Tendencies in Industrial Education in Pennsylvania," Dr. F. T. Struck, assistant director of vocational education for Pennsylvania; "The Intensive Course in the Industrial Arts," Allen D. Backus, Newark, New Jersey.

Mr. M. M. Walter, director of vocational education, Coatesville, Pennsylvania acted as chairman of this meeting.

—ALLEN D. BACKUS.

INDUSTRIAL WORK IN NEW ORLEANS

JOHN L. PEARCE, supervisor of manual training in the New Orleans City Schools, gives the following interesting sketch of the work in New Orleans:

"Manual Training was established in the Orleans Parish Schools during the session 1911-12. At that time the work was given to the boys of the seventh and eighth grades and was optional. After some two years this work was made a part of the course of study and all pupils were required to take it along with their other studies. Up to the present year the work has been given in only the seventh and eighth grades but during the present session it was extended so as to include the sixth grades.

"The department was opened with three centers and two instructors who were required to cover the

entire city. It now consists of nineteen white and two colored centers in which are employed one supervisor and twelve white teachers and three colored teachers

"The classes are held for ninety minute periods and each pupil is given one lesson per week. Each teacher handles fifteen classes per week.

"The projects are much the same as those seen thruout the various states. The sixth grade 'B' pupils construct first a broom holder of one or another of two designs. This project together with the making of a mechanical drawing of the same article, and the necessary tool and technical instruction usually requires the entire semester or term. The pupil is then given a simple tabouret design as a model from which he gets general dimensions and which he takes as a pattern for a mechanical drawing. The pupil is permitted in this project to vary the design in an effort to assist him in developing his powers of design. This project is completed, stained, varnished, and polished in the sixth 'A' grade by the average pupil.

"In the seventh grade the pupil is permitted to choose a project embodying mortise and tennon joints. In the choice of this project the instructor permits the selection of only such a project as in his judgment is within the ability of the pupil and the time in which he has to complete it.

"During the first half of the eighth grade the pupil is required to construct, either in a group or alone, some project for his own or the school system in general. These projects vary from the simplest shelf to more complicated projects such as cabinets and desks.

"The latter half of the eighth grade is devoted to a course in home mechanics. In this class are solved many of the problems that confront the average house holder. The pupil is instructed to bring his own particular problem to class where it is solved for the entire group.

"In addition to the white centers we have centers for colored pupils. Our colored high school is equipped with power driven machinery. Here many projects are developed and the student given the best possible instruction and practical experience.

"In addition to the woodworking shops we have just equipped one of our centers with a printing press at a cost of over one thousand dollars. This equipment was a gift to the school from the parents club of the school. In this shop all the stationery of the school, tickets, cards, and a school paper are printed."

—E. A. FUNKHOUSER.

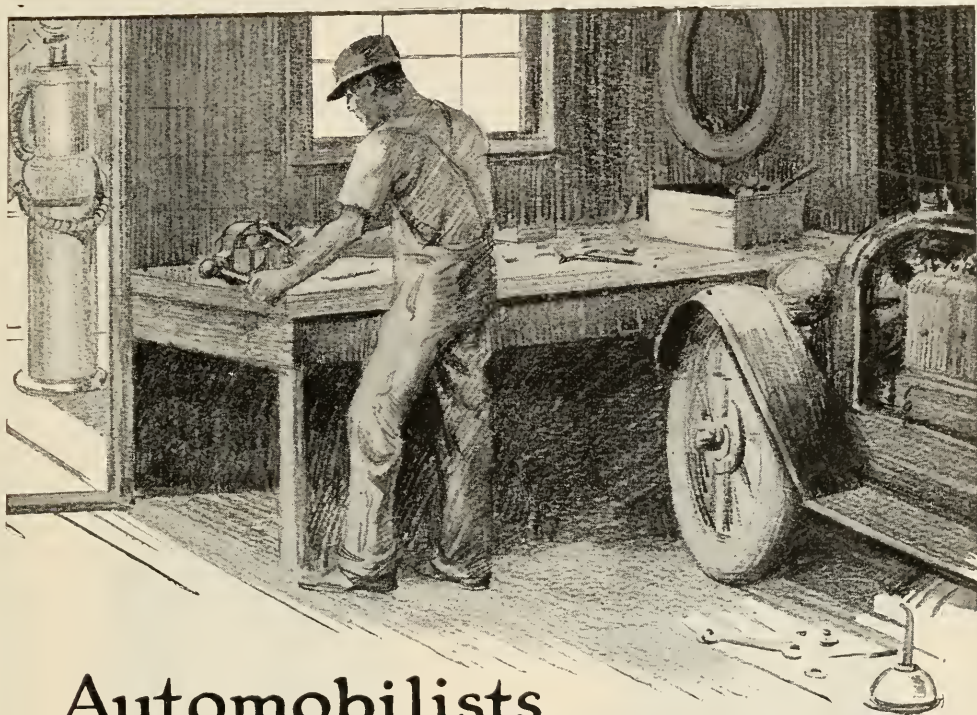

Automobilists and Motor Mechanics

Starrett



Thickness Gage No. 71

Contains six leaves particularly adapted for adjusting motor tappets. Also useful for gaging slots. The six leaves have, respectively thickness of .0015, .002, .003, .004, .006 and .015. Auto mechanics have been looking for this tool.

who know Starrett Tools prefer them for their superior quality, more efficient design, greater durability and dependable precision.

When they buy Starrett Tools they know they're getting value for every penny spent. Illustrations and complete descriptions of the entire Starrett line of fine tools are given in the Starrett Catalog No. 22 "EF" and Special Supplement of new tools. Copies free on request.

THE L. S. STARRETT CO.

*The World's Greatest Toolmakers
Manufacturers of Hacksaws Unexcelled
ATHOL, MASS.*

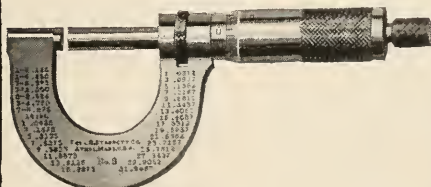

Starrett



T-Handle Tap Wrench No. 93

An extremely handy tool for holding practically all small tools to be turned by hand. New clamp construction insures firm grip on tool. Heat treated jaws guarantee durability.



Use Starrett Tools



FIELD NOTES—(Continued)

BOYS OPERATE MODEL SCHOOL

THE accompanying photographs are those of Elton Heglund, of the West Intermediate School, and Basil Melville, of the East Intermediate School, of Jackson, Michigan. These boys were selected to represent their respective schools at the National Sheet-Metal Contractors Convention and



ELTON HEGLUND, OF THE WEST INTERMEDIATE SCHOOLS, JACKSON, MICHIGAN

Exposition which was held in Cadle Auditorium, Indianapolis, Indiana, May 15 to 19. The boys worked in the model school shop during the convention.

Thru their superior ability and workmanship these boys won this opportunity in competition with the other boys of the sheet-metal classes. The plan of sending these boys to the convention was made possible thru the interest and co-operation of the sheet-metal contractors of the city with the sheet-metal departments in the school.

The total expenses of the boys, while attending the convention were defrayed by the Jackson Local Organization. The sheet-metal work in the Jackson Schools was installed thru the influence of the Jackson Sheet-Metal Contractors Association.

The course of study in the schools consists of the making of kitchen utensils, blow-pipe and furnace construction eave troughing and cornice work and problems involving triangulation.

The work of the West Intermediate School is under the supervision of Fred L. Barnum and that of the East Intermediate, of Deyo B. Fox.

CALIFORNIA FIELD NOTES

CO-OPERATION OF INDUSTRY AND SCHOOLS

RECENTLY a special meeting was called in San Francisco by the Industrial Relations Association of California to discuss a matter which has long needed serious and competent discussion, namely: "Co-operation between our schools, business, and industry." The speakers at this meeting, which was more in the nature of a mass meeting than a regular gathering, included persons of this state whose opinions on the subject are most highly valued. Among the speakers were our State Superintendent Will C. Wood, who made an address on the topic, "How Can the Business Men



BASIL MELVILLE, OF THE EAST INTERMEDIATE SCHOOLS, JACKSON, MICHIGAN

of California Co-operate with the California School System to the Increased Advantage of Both." Among the other speakers were the President of Stanford University, Raymond Lyman Wilber; Professor H. R. Hatfield, of the University of California; Alfred J. Esberger, a member of the newly created, board of education of the San Francisco Schools; R. B. Hale, the Senior member of Hale Brothers, which is one of the largest department stores of San Francisco; and Dr. B. M. Rastall, who some time ago made an industrial survey of the "San Francisco Metropolitan District" under the direction of the San Francisco Chamber of Commerce, for the purpose of determining what extension of industry might profitably be under-



*Academic, Art and Industrial Education
are combined in*
Printing

ENGLISH, spelling, punctuation, paragraphing, correct design, capitalization, harmonious color arrangements, color mixing, and technical processes always coordinate if Printing is used as an educational tool.

In North American schools and institutions, from coast to coast and from Canada to the Gulf of Mexico, instruction by means of Printing is making education a happy and interesting attainment.

Costs of installation, outfit and supplies are usually much lower than those of purely industrial subjects which do not coordinate with academic and art phases.

Teach with Printing

Write for literature, course of study and prices

F. K. PHILLIPS, *Manager*, EDUCATION DEPARTMENT

AMERICAN TYPE FOUNDERS COMPANY

300 COMMUNIPAW AVENUE

JERSEY CITY, NEW JERSEY





FIELD NOTES—(Continued)

taken in the district bordering on the San Francisco Bay. The meeting was arranged by V. T. Fisher, the executive secretary of the Industrial Relations Association.

REAL CARPENTRY IS BEING DONE IN SCHOOLS

All over the State, teachers of carpentry are endeavoring to get away from the model-house type of carpentry instruction, which has been common in the past, and still prevails to a large extent. In its endeavor to promote this type of carpentry instruction, the State Office is suggesting that school authorities should endeavor to find some local person who would be willing to advance the money necessary for the purchase of a building-lot somewhat near the school and for the payment for material. Or, if such a person can not be found, it is recommended that the local Chamber of Commerce or some civic organization be invited to advance the money. That practical carpentry can be satisfactorily done, and that plans for providing the lot on which to build and the material with which to do the building can be realized, is being demonstrated very definitely at the little city of Exeter. Here John R. Altucker, the instructor, is just completing a second house and is about to begin a third. Every aspect of the construction and finishing is done by the students under Mr. Altucker's instruction and direction. This statement does not apply, however, to the plumbing and electric wiring which may not be done by the pupils because these two phases of building construction are required by law to be done by licensed tradesmen.

WHITTIER GIVES SPECIAL ATTENTION TO OCCUPATIONAL INSTRUCTION

The Whittier State School is an institution designed to take care of the "problem child" of our state. The children are committed to the school by some superior court in the state. Their training, so far as schooling is concerned, may be divided into two branches—academic and vocational. For the senior group of the school, comprising over two-thirds of the boys, the vocational instruction is given a most prominent place. In fact, educationally considered, the Whittier State School is held to be primarily a vocational school. It is held that this particular feature of the work is what distinguishes the educational policy of the school from that which prevails in the regular public school. The vocations which are taught embrace: building trades, including carpentry, cab-

inet-making, painting, and plumbing; machinery trades, covering blacksmithing, machine shop work, icemaking, power-house, and automobile work in garage; printing trades, embracing book-binding, typography, platen presswork, and time-keeping; and also several aspects of culinary trades, musical occupations, and ranch occupations.

To determine in which one of these general divisions of vocational activity a given pupil should be assigned, dependence is placed upon a plan of vocational guidance. The plan consists first of finding the qualifications and interests of the boys. The data obtained includes the boy's previous educational training, his intelligence level and his ability, the home from which he comes, and the opportunities in the place to which he will return after leaving the school. Together with this is considered the boy's statement as to the trade in which he is or might be interested. This data is considered by a committee consisting of the school principal, the chief supervisor, the farm manager, the school superintendent, and the assistant superintendent, meeting as a guidance committee. The decision of the committee, is, however, tentative until after the boy has been tried out in the vocational work. Should he prove unfit for the work, he is then tried out in some other field; and transfers are made as often as necessary to locate the individual to best advantage. At times transfers are made not necessarily because of lack of ability on the part of the pupil, but primarily because of lack of interest.

The method of instruction thruout the vocational work is on the apprenticeship basis. Men in charge of the work, tho rated as instructors, are in reality production men in their particular occupations. The work which these men and their apprentices do is of the type needed in the institution. The boys act as helpers to the instructors, and do the work under their supervision, while the instructors at the same time carry along the necessary amount of actual production themselves. In this way the instructors act in the capacity of masters, teaching their apprentices very much as did the masters of the great guilds in England during the Elizabethan era. Thus, the apprenticeship in Whittier is real old-time apprenticeship, involving instruction in the practical methods of the trade, while work is done on productive tasks in the course of which work whatever theoretical explanation is given arises out of the immediate work in hand.

—CHAS. L. JACOBS.

The Peer of All Manual Training Band Scroll Saws

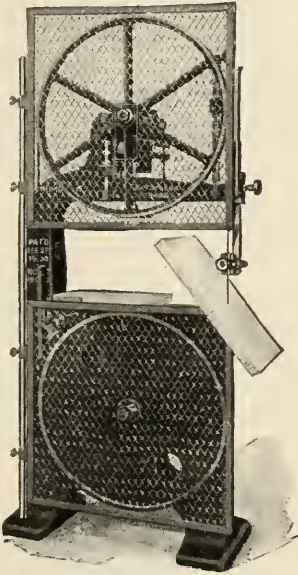

Showing Wire Mesh Guards over both
Wheels and Table Angled.

No. 155 "Lightning" Pat. 30-inch Band Scroll Saw

Hundreds of manual training school officials throughout the country have conceded that the Fay & Egan No. 155 Band Scroll Saw is the Standard Saw for manual training purposes. No other 30" saw can equal it in amount of work produced and low up-keep cost.

Its patented construction permits the use of the thinnest blades at high speeds without danger of breaking.

*Write for Descriptive Bulletin M-3 explaining
the wonderful advantages of the No. 155*

J. A. FAY & EGAN COMPANY

ESTABLISHED 1830

World's Oldest and Largest Manufacturers
of Woodworking Machinery



730-750 W. Front St.

CINCINNATI, OHIO

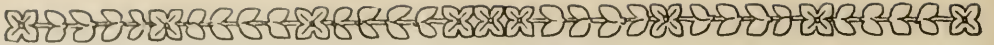

REVISED LIST OF MEMBERS
EDUCATIONAL PRESS ASSOCIATION OF AMERICA

1922

President—ARTHUR H. CHAMBERLAIN, San Francisco, California
Secretary—GEORGE L. TOWNE, Lincoln, Nebraska
Treasurer—M. P. HELM, Indianapolis, Indiana
Executive Committee { HENRY G. WILLIAMS, Columbus, Ohio
 CHAS. F. PYE, Des Moines, Iowa

MEMBERS

MAGAZINE	EDITOR
<i>American Education</i> , Albany, New York	C. W. BLESSING
<i>American School</i> , Milwaukee, Wisconsin	C. G. PEARSE
<i>American School Board Journal</i> , Milwaukee, Wisconsin	W. C. BRUCE
<i>Colorado School Journal</i> , Denver	D. R. HATCH
<i>Administration and Supervision</i> , Baltimore, Maryland	} H. E. BUCKHOLZ
<i>Journal of Educational Psychology</i> , Baltimore, Maryland	
<i>Educator-Journal</i> , Indianapolis, Indiana	M. P. HELM
<i>Florida School Journal</i> , Zephyrhills, Florida	P. W. CORR
<i>Journal of Education</i> , Boston, Massachusetts	A. E. WINSHIP
<i>Kansas Teacher</i> , Topeka, Kansas	F. L. PINNETT
<i>Kindergarten-Primary Magazine</i> , Manistee, Michigan	J. H. SHULTS
<i>Manual Training Magazine</i> , Peoria, Illinois	CHAS. A. BENNETT
<i>Moderator-Topics</i> , Lansing, Michigan	W. T. BISHOP
<i>Missouri School Journal</i> , Jefferson City, Missouri	A. S. LEHR
<i>Midland Schools</i> , Des Moines, Iowa	CHAS. F. PYE
<i>National Geographic Magazine</i> , Washington, D. C.	GILBERT H. GROSVENOR
<i>Nebraska Teacher</i> , Lincoln	GEORGE L. TOWNE
<i>New Mexico Journal of Education</i> , Santa Fe, New Mexico	
<i>Ohio Educational Monthly</i> , Columbus, Ohio	J. L. CLIFTON
<i>Ohio Teacher</i> , Columbus, Ohio	HENRY G. WILLIAMS
<i>School Index</i> , Cincinnati, Ohio	H. L. SENGER
<i>Pennsylvania School Journal</i> , Harrisburg, Pennsylvania	
<i>Popular Educator</i> , Chicago, Illinois	E. S. SMITH
<i>Primary Education</i> , Boston, Massachusetts	MRS. WHITING
<i>Porto Rico School Review</i> , San Juan, Porto Rico	CAREY HICKLE
<i>School and Home Education</i> , Bloomington, Illinois	GEORGE BROWN
<i>School Century</i> , Oak Park, Illinois	GEORGE W. JONES
<i>School Science and Mathematics</i> , Chicago, Illinois	CHAS. SMITH
<i>School News</i> , Taylorville, Ill.	L. L. PARKER
<i>School News</i> , Newark New Jersey	JOHN C. EVANS
<i>Sierra Educational News</i> , San Francisco, California	ARTHUR CHAMBERLAIN
<i>Southern School Journal</i> , Lexington, Kentucky	R. S. EUBANK
<i>Southern School Work</i> , Alexandria, Louisiana	C. R. REAGAN
<i>South Dakota Educator</i> , Mitchell, South Dakota	F. L. RANSOM
<i>Texas School Journal</i> , Dallas, Texas	H. T. MUSSELMAN
<i>Utah Educational Review</i> , Salt Lake City, Utah	L. E. COWLES
<i>Wisconsin Journal of Education</i> , Madison, Wisconsin	W. N. PARKER

LITTLE GIANT

MANUAL TRAINING DEPARTMENT

Special Equipment

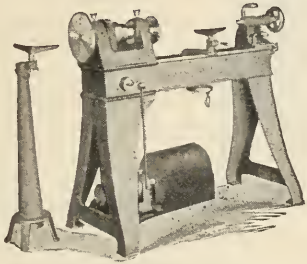

LITTLE GIANT WOOD LATHES

Individual Motor Driven, or Belt Driven from above or beneath.

Furnished with either Bench or Floor Legs. Wide choice of optional tools and equipment. Four speeds.

Many new, exclusive and practical features. All bearings are Hyatt High Duty Roller Bearings which greatly reduce power required. Ball Thrust bearings at all points of end thrust.

Sold on 30 days trial, and **GUARANTEED FOREVER** against defective material and workmanship.

LITTLE GIANT METAL LATHES

Individual Motor Driven, or Belt Driven from above or beneath.

Furnished with either Bench or Floor Legs. Wide choice of optional equipment. Three speeds.

Many new, exclusive and practical features are also found on our metal lathes. They are fitted to receive attachments for grinding, milling, gear cutting, etc., all of which we will furnish at a small fraction of the cost of a separate machine for such work.

Sold on 30 days trial and **GUARANTEED FOREVER** against defective material and workmanship.

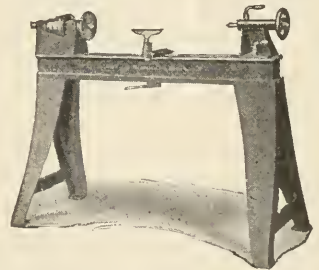

LITTLE GIANT POWER HAMMERS

Individual Motor Driven, or Belt Driven from above. Hundreds of different form-forging dies for instruction purposes.

Standard equipment with leading Technical and Manual Training Institutions.

Sold on 30 days trial, and **GUARANTEED FOREVER** against defective material and workmanship.



DO NOT OVERLOOK

Metal Working Equipment in your school. Wood can never be made anything else, while metal working and alloying are in their infancy.

The Industrial Leaders of the world, to a very large extent, began as metal workers.

Wood working is artistic, and trains mind, eye and hand to deftness. Metal working does all this, and more. It is also practical, and the graduate invariably finds a position waiting for him, while the wood working department graduate usually takes up something else and his instruction is forgotten.

Little Giant Equipment for Technical and Manual Training Schools consists of a full line of all metal and wood working machinery including accessories and tools for same.

On Motor Driven Equipment, information will be required as to Current, Voltage, Phase and Cycles of Motor.

Our business commenced in January, 1876, more than 45 years ago, and our Little Giant Products are used throughout the world. We are anxious to serve you for we can do it well.

Quotations and descriptive literature can be secured from any jobber, or direct from us.



LITTLE GIANT COMPANY

220 ROCK ST.

MANKATO, MINN., U. S. A.



FIELD NOTES—(Continued)

AROUND NEW YORK

THE convention of the Workers' Education Bureau, a nation-wide organization devoted to the distribution and the organization of labor education, began on Saturday morning, April 22. At a meeting of the Teachers' Union on Friday evening, April 21, held in the Ceremonial Hall of the Ethical Culture Society, an address was given by Spencer Miller, secretary of the Workers' Educational Bureau, on the problem of the workers' education.

SCHOOL ART LEAGUE ACTIVITIES

The School Art League is seeking thru a special committee to enlist the co-operation of a number of commercial concerns employing designers, in its scholarship plan. The committee has sent out a letter to the trade asking each concern to contribute \$100 a year to enable two high school graduate pupils—one in February and one in September—to go to an art school for an additional year of intensive training in industrial art.

In asking support of its scholarship plan, the letter of the committee emphasizes the following facts:

1) This country lacks industrial art workers, and will continue to lack them until there is more and better training. The high-school system in New York City is now carefully sifting out all boys and girls who show decided talent. It is for the ultimate benefit of the industries that this is being done. No elaborate argument is needed to urge the wisdom of assistance in every possible way by the industries.

2) Post-graduate courses in industrial arts have been awarded thru the School Art League to over 150 boys and girls, graduates of city high schools. Many of these young people are now in the trade doing excellent work. The number to be aided is growing larger as the high schools develop this special training of gifted pupils. There are twenty-seven high schools in the city, and if each school sent forward but one pupil a term, fifty-four scholarships would have to be provided each year for these talented boys and girls. The League at present is taking care of about thirty-five graduates. It needs your help to assist other students.

3) The successful operation of this plan has been proved by the League, which has been awarding these scholarships for the last ten years. It is a co-operative plan whereby the art schools make a special rate for tuition. The high schools graduating the pupils contribute a share thru their school activities to help forward their gifted mates, and the balance is raised by the School Art League.

NEW YORK TO BE WORLD CENTER OF SALESMANSHIP

At the second annual dinner of the New York University School of Retailing, the co-operation of the merchants of the city with the New York University in making New York the world center of retail salesmanship and education was discussed. The members included business men, educators and students. Various phases of the problem in hand were presented by Percy S. Strauss, vice-president of R. H. Macy & Co.; Colonel Friedsam, president of B. Altman & Co.; Chancellor Elmer Brown of New York University; Dean John Withers of the New York University School of Education; Dr. Norris Briscoe, director of the School of Retailing. Samuel W. Reyburn, president of Lord and Taylor, was Toastmaster.

Both Colonel Friedsam and Mr. Strauss emphasized the need for a more intelligent personnel in the great department stores. Altho 95% of the great retail merchants are men who have had no more than an elementary school education, Colonel Friedsam stated that conditions in the business world are changing, and that the college man is becoming more and more of an asset. "The college man's aversion for retail-selling work," he said, "is rapidly disappearing."

"Retail-selling problems have become so complete," declared Dr. Briscoe, "that trained minds are an imperative necessity. The old school of experience was too long and too expensive. In the new school we try to link together the classroom and the store, and to eliminate the haphazard and imperfect process of learning the business."

Chancellor Brown pointed out that the institution of the School of Retailing is only a part of New York University's ambitious program. "We are trying to bring education into closer touch with the daily affairs of humanity. In carrying out this plan we hope to finally knit together the social and industrial forces of this great city, and the educational energy of New York University."

Dean Withers dwelt upon the importance of vocational education in the problem of world reconstruction. "Ten millions of producers have been killed," he said. "Men must be trained to take their places. But we must also educate the people to buy the things that are produced. This is the special service of the retailer. More money is spent today on travelling salesmen than on school teachers. We must teach men to be skilful in some occupation, to use the product of others, and to co-operate."

"Vocational education," said Mr. Reyburn, "must take the place of the old system of apprentice-

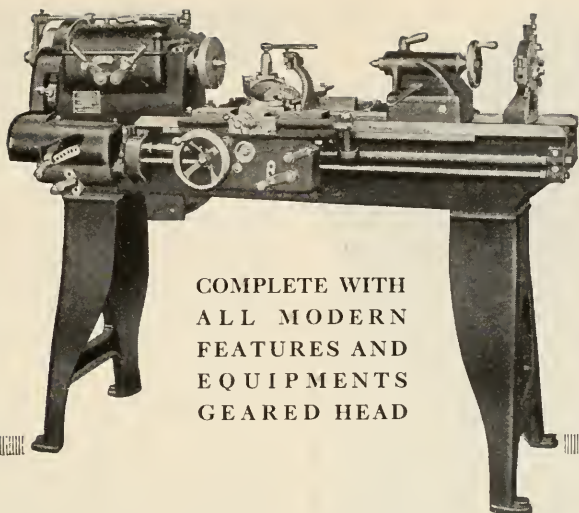

COMPLETE WITH
ALL MODERN
FEATURES AND
EQUIPMENTS
GEARED HEAD

SIDNEY ENGINE LATHES

Meet Every School Shop Requirement

Write for Interesting Descriptive Matter

THE SIDNEY MACHINE TOOL CO.

SIDNEY, OHIO

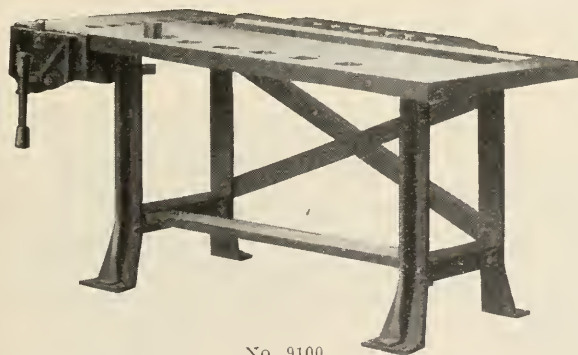

No. 9100

Built To Give Enduring Satisfaction—

Mr. Arthur Kinkade of the Board of Education of Decatur, Ill., writes of the laboratory equipment furnished by us for the new Roosevelt Junior High School:

"The cases, tables, desks and special pieces made by you are, in my judgment, very high quality, indeed. I believe I know cabinet work when I see it, having spent some ten years in the wood-working trade, and I want to say that you have an excellent product."

Consult us when you want standard or built-to-order manual training or laboratory equipment. Keep our catalog on file.

Wiese Laboratory Furniture Co.
ENGINEERS AND BUILDERS
Factory: Manitowoc, Wisconsin

WIESE LABORATORY FURNITURE

Ask for our new Catalog No. 28

SALES OFFICES:

14 E. Jackson Blvd., Chicago, Ill.
806 Observatory Bldg., Des Moines,
Ia.
514 Kemper Bldg., Kansas City, Mo.
Louisville, Kentucky.
Otterbein, Indiana.
121 Chartres St., New Orleans, La.
244 Third Street, Portland, Ore.
1610 Bryan St., Dallas, Tex.
101 Market St., Harrisburg, Pa.
24-26 First Street, S., Minneapolis,
Minn.
166 Waverly Place, New York, N. Y.
310 East Bridge St., Streator, Ill.



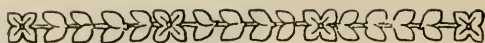

FIELD NOTES—(Continued)

ship which has fallen into disuse. Groups of merchants, acting thru the universities and schools, can make the student an effective agent for carrying on the world's work."

More than 200 students are attending classes at the School of Retailing, which was made possible thru the co-operation of twenty-three of the larger retail houses of the city. Policies of the school are largely determined by an advisory council of store executives.

—W. H. DOOLEY.

MINNESOTA NOTES

DEAN M. SCHWEICKHARD, of Clinton, Iowa, has been appointed supervisor of trade and industrial education of the state board of education. Mr. Schweickhard succeeds G. A. McGarvey, whose resignation the board accepted. The new appointee will assume office June 15. He has for some time been director of industrial arts and vocational education at Clinton, Iowa.

TWO DINNER CONFERENCES

Two dinner meetings of those interested in industrial and manual arts were held during the annual schoolmen's week held at the University

(Continued on page XXII)



See these books for 10 days FREE

Good's Ford Car, Truck and Tractor Repair, \$2.00.

Dawes' Direct Currents, \$4.00

Dawes' Alternating Currents, \$4.00.

Longfield's Sheet Metal Drafting, \$2.25.

Palmer's Practical Mathematics. Part I, Arithmetic with Applications, \$1.25. Part II, Geometry with Applications, \$1.25. Part III, Algebra with Applications, \$1.25. Part IV, Trigonometry and Logarithms, \$1.25.

Croft's Practical Electricity, \$3.00.

Hobbs, Elliott and Consoliver's Gasoline Automobile, \$3.00

Moyer's Gasoline Automobile, \$2.00.

Burghardt's The Lathe, Benchwork and Work at the Forge, \$2.25.

Colvin and Stanley's American Machinists' Handbook, \$4.00.

Seaton's Concrete Construction for Rural Communities, \$2.25.

FREE EXAMINATION COUPON

McGraw-Hill Book Co., Inc.
370 Seventh Ave., New York

You may send me on 10 days' approval

I agree to pay for the books or return them, postpaid, within 10 days of receipt.

Signed

School

Official Position

Address

M.T.M. 6-1-22

Carnegie Institute of Technology Summer Session

Courses for Teachers of Manual and Industrial Arts

July 5 to Aug. 12, 1922

Exceptional Shop Facilities

Courses in Manual Arts Education, Woodworking, Cabinetmaking, Sheet Metal Work, Drafting.

Other shops open to teachers—Machine, Patternmaking, Forge, Electric Equipment, Plumbing, Automobile.

Instruction given by regular members of the faculty.

Wide range of subjects offered by other departments.

For catalogue and further information, address the

REGISTRAR, Box M, CARNEGIE INSTITUTE OF TECHNOLOGY

Schenley Park, Pittsburgh, Pa.

No More Loose Handles

Don't take chances with Hammers with ordinary Wedges when you can now secure the **UNCLE SAM BRAND** Hammers with the new **VAUGHAN'S EXPANSION WEDGE**.

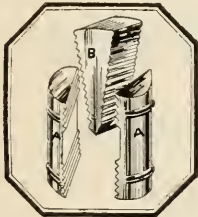

If the handle shows any tendency to become loose simply set the Wedge (B) a notch or two deeper between the pins (A) and a tight handle is assured.

UNCLE SAM HAMMERS are the only Hammers that have been approved by the **UNDERWRITERS' LABORATORIES** and each Hammer has the Underwriters' Label. It took 900 lbs. more pressure to pull the handle through the head with the **VAUGHAN'S EXPANSION WEDGE** than with the Ordinary Wedge. Uncle Sam Hammers are made in all patterns and sizes. *Write for description booklet No. 10 which describes this line in detail.*

VAUGHAN & BUSHNELL MFG. CO.

2114
Carroll
Ave.



Chicago,
U. S. A.

Specialists in Manual Training Lumber

Maisey & Dion Hardwoods

KILN DRIED AND AIR DRIED

OFFICE & YARDS 2349 TO 2423 So. LOOMIS ST.

TELEPHONES

CANAL 1830

CANAL 1831

CANAL 118

CHICAGO

THE

Great Central Market

"ECONOMY" 12-inch Swing

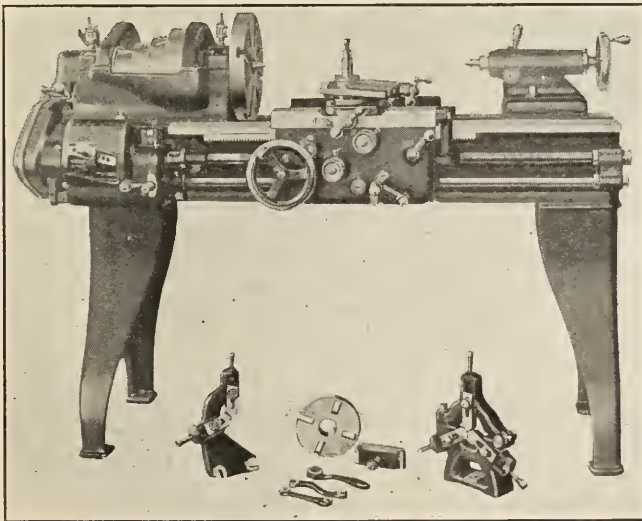

Single Back Geared
Quick Change

Engine Lathe

THIS lathe is designed especially to meet modern demands in commercial and school shops for a small heavy duty machine. It is high grade and extremely accurate. Before you select or specify for your shop

BE SURE to consider this lathe. Study the specifications and note the many special features of bed, headstock, tailstock, carriage, apron and gear box.

*Write today for
Descriptive Circular*

ROCKFORD LATHE & DRILL COMPANY, Rockford, Illinois

Manual Training Magazine

JUNE, 1922

NEW YORK CITY TEXTILE HIGH SCHOOL

W. H. DOOLEY

Principal

THE New York City Board of Education has recently established a unit technical high school to meet the educational needs of the leading industry of the city. Since this is the first unit vocational high school—that is the first technical high school devoted to a single industry—in the country, it may be well, first, to discuss the importance, aim and value of such a school.

According to recent census reports and surveys made by the trade organizations, New York City is the largest distributing and selling point for textiles in the world. It is, in addition, the style center of the country, and a growing manufacturing center for the highest grades of textiles, such as outer knitted fabrics, garments, upholstery, carpets, dyestuffs, laces, etc. The following represents some of the leading trades:

- Upholstery trades.
- Wholesale and retail dry goods trades.
- Wholesale and jobbers of woolen goods.
- Wholesalers and jobbers of cotton goods.
- Converters of cotton goods.
- Wholesale and retail trade.
- Retailers in fibres—cotton, wool, linen, silk, etc.
- Knitting and sweater manufacture (over 500 small mills in the city.)
- Carpet and rug manufacture.
- Dye manufacture.
- Wholesale dealers of dyes.
- Handicraft textile trades.
- Clothing trades.

The number of people employed in the textile branches is 694,438 compared

with 251,895 engaged in the combined metal trades and 93,750 engaged in the woodworking trades. The textile trades represent the most and leading lines of business in the community, and contribute a large part of the money raised by taxation.

Recent investigations show that most of the experts in the textile lines in New York are born and trained in Europe. This does not mean necessarily, that people of foreign birth are more intelligent or better adapted to the work than our men and women, but it does indicate that their education has afforded opportunity for them to prepare specifically for the textile trades. Can it be that our educators have not seen the possibilities of textile work or have considered it a subject unworthy of study and research? Certain it is, that heretofore our schools and colleges have not offered a sufficient number and variety of courses along this line to make it possible for students to specialize in textiles.

The subject of textiles is rich in opportunities for the application of mathematics, chemistry, physics, biology, economics, etc. Every fabric is carefully laid out on paper with definite specifications as to weight, raw material, size of yarn, construction, sizing, and dyeing, according to the use for which the fabric is intended. Each specification may be varied to meet draping qualities, power to resist friction or textile strength and to sell at a price within the reach of a certain class of consumers. The value of textile material in education was recognized many years

ago by one of the leading educators and psychologists, Dr. John Dewey. Of all the factory industries in this country today, the only one that has successfully applied technical education to the trade is the textile industry.

As has been applied, foreign countries long ago recognized the importance of textiles in meeting the educational needs of that industry. As far back as the cloth-worker guild, opportunity was afforded for the training in textiles. Later well-equipped textile schools were established over Europe to train young people in the arts and applied science of textiles. Later such schools were established in the United States. Since there are different grades of textile industries there must be different types of schools to meet the needs. Textile schools may be of the following types: college grade, secondary or high school grade, and intermediate or trade (continuation) school grade. Practically all institutes in this country which provide textile education aim to be of collegiate grade like the Lowell Textile School and the Philadelphia Textile School. They provide a training for students over eighteen years of age who have had a high school education or its equivalent. (This is due to the fact that, at the time textile schools were established in the early eighties, they were patterned after the technical schools of the time, such as the institutes of technology, which were of college grade. The secondary school of mechanic or technical arts had not at this time been established.)

Up to the establishment of the New York City Textile School two years ago, little, if any, effort had been made to supply textile education of a secondary grade. It is true there were high schools of the mechanical trades (machinists, electricians, etc.), but little had been done in the textile trades. The textile trade

school offers short unit courses of instruction in operating machines. Sometimes short day courses are also offered. The Textile School was organized by the Board of Education in response to a united demand of the following textile organizations: Silk Association, Upholstery Association, Sweater and Knit Goods Association, Cotton Converters Association, United Dress Waist League, Federation of Art Societies, chemical and dyestuff trade, the millinery and retail dry goods associations, working in harmony with the United Textile Workers of America.

The New York City Textile High School is a vocational school of high-school grade. That is, it prepares boys and girls directly for the textile grades, while in age of pupils, length of courses, and preparatory requirements it corresponds to other high schools. This requires four-year courses, following the completion of an eight-year elementary course, and strictly speaking, should include pupils fourteen to eighteen years old. In this School the course of study is divided into two parts. The first, a two-year's preparatory course offering a foundation of academic and technical subjects, aims to develop general and industrial intelligence. The second part is distinctly vocational. Experience shows that textile education taught to those under sixteen years of age is not very effective, that it is better to give all general educational work first and intensive vocational work in the last two years, rather than to distribute the textile work over the four years. The vocational work is divided into courses to meet the needs of the various branches of the textile industry, as, General Textiles, Marketing of Textiles, Textile Manufacturing and Engineering, Textile Chemistry and Dyeing, Costume Design, Applied Textile Design.

SUBJECTS		Required or Elective	Weeks	Lessons per week	SUBJECTS		Required or Elective	Weeks	Lessons per week	SUBJECTS		Required or Elective	Weeks	Lessons per week
GENERAL COURSE IN TEXTILES					MARKETING OF TEXTILES					MANUFACTURING AND ENGINEERING				
DESIGN COURSE (Costume and Applied Textile)					CHEMISTRY AND DYEING									
English	English	R	40	4	English	English	R	40	4	English	English	R	40	4
Algebra	Algebra, Arithmetic	R	40	5	Algebra	French	R	40	5	Algebra	Algebra	R	40	5
Foreign Language	Foreign Language	E	40	5	Foreign Language	Civics	E	40	5	Biology	Biology	E	40	5
Civics	Civics	R	40	4	Civics	Mechanical Drawing	R	40	4	Foreign Language	Foreign Language	R	40	5
Science	Stenography and Typewriting	E	40	5	Shopwork	Science	R	40	5	Civics	Civics	R	40	4
Biology	Bookkeeping	E	40	5	Science	Science	E	40	5	Science	Science	E	40	5
	Science	E	40	5										
English	English	R	40	4	English	English	R	40	4	English	English	R	40	4
Geometry	Geometry	E	40	5	Geometry	Geometry	R	40	5	Geometry	Geometry	E	40	5
Foreign Language	Foreign Language	E	40	5	Foreign Language	History	E	40	5	Foreign Language	Foreign Language	E	40	5
History	History	R	40	5	History	Mechanical Drawing	E	40	5	Chemistry	Chemistry	R	40	5
Science	Stenography and Typewriting	R	40	5	Shopwork	Physics	R	40	5	History	History	E	40	5
	Bookkeeping	R	40	4										
	Science, Raw Material	R	40	5										

VOCATIONAL DEPARTMENT

English	English	R	40	4	English	English	R	40	4	English	English	R	40	4
Chemistry	Chemistry	R	40	5	Chemistry	Chemistry	R	40	5	Physics	Physics	R	40	5
Physics	Physics	R	40	5	Physics (advanced)	Museum Work	R	40	5	Qualitative and Quantitative Analysis	Qualitative and Quantitative Analysis	R	40	10
Drawing, Design	Economics	R	40	5	Textile Subjects, (Carding, Spinning, Weaving)	Applied Tex. Design	E	40	18	Dyeing	Dyeing	R	40	6
Textile Subjects	Textile Subjects, (Carding, Spinning, Weaving, Cloth Analysis)	R	40	16		Costume Illustrating	E	40	9	Organic Chemistry	Organic Chemistry	R	40	6
						Costume Cutting	E	40	9	General Textiles	General Textiles	R	40	5
English	English	R	40	4	English	English	R	40	4	English	English	R	40	4
Amer. Hist., Civics	Amer. Hist., Civics	R	40	5	Amer. Hist., Civics	Amer. Hist., Civics	R	40	8	Amer. Hist., Civics	Amer. Hist., Civics	R	40	5
Drawing, Design	Salesmanship	R	40	5	Advanced Mathematics	Museum Work	R	40	5	General Textiles	General Textiles	R	40	5
Cost Accounting	Period Decoration	R	40	5	Textile Subjects (Weaving, Dyeing, Finishing)	Textile Subjects	R	40	20	Quantitative Analysis	Quantitative Analysis	R	40	10
Textile Subjects (Weaving, Dyeing, Finishing)	Textile Subjects (Weaving, Dyeing, Finishing)	R	40	16		Applied Tex. Design	E	40	18	Organic Chemistry	Organic Chemistry	R	40	6
						Costume Illustrating	E	40	9	Dyeing	Dyeing	R	40	6
						Costume Cutting	E	40	9			R	40	6

The General Textile Course aims to provide a general knowledge of textiles, and is adapted to the boy and girl who desires to enter the textile world but has no definite plans as to the specific branch. That is, it is planned for the pupil who desires a broad general training in the practice and theory of cotton, woolen, worsted, silk yarn and fabric manufacture. Among the subjects considered are weave, formation, analysis of fabrics, knitting, warp preparation and weaving, cotton yarn manufacture, woolen and worsted yarn manufacture, silk yarn manufacture, chemistry, dyeing and finishing.

The Marketing of Textiles is the most popular course in the School. This is not surprising, when one considers that the selling of textiles is the largest field in the city. The distinction of textiles is becoming very exacting. Years ago, people purchased and sold textiles on name, but to-day, due to competition, there is an ever-increasing demand to buy and sell on merit alone. All this means that every purchasing and selling agent must know textiles sufficiently well to bring to their selection fine discriminations in the form of selling points. The purpose of the course in the marketing of textiles is to fit young men and women for responsible positions in the wholesale and retail textile trades, where it is necessary to have a knowledge of the construction of all kinds of textiles as well as a knowledge of period decorations.

The Textile Manufacturing and Engineering Course aims to give a training that will prepare young men to enter either the manufacturing or power department of a textile mill, and later rise to responsible positions as overseers, superintendents, etc. This course differs from the general course in textiles by devoting more time to the operating, repairing and mechanism of weaving,

knitting and finishing machines. In other words, it is intended for those who desire to enter the productive side of the industry. The production of textiles depends to a large extent, not only on the skill of the operators, but also on the speed of the machines and the efficiency of the mechanical devices used in preparing the raw material. Thus, the content of this course is quite different from that of the marketing course where emphasis is placed on the finished fabric, with only such knowledge of manufacturing as is necessary to understand the defect in fabrics, and such "finishes" on fabrics as increase or decrease the value. The manufacturing course does not deal so much with the finished cloth as with the layout of the mill, power, transmission, etc.

Textile Chemistry and Dyeing gives that theoretical and practical training which should enable young men or women to find employment as assistants in textile and dye laboratories, conditioning and testing houses and mills.

Costume Design offers a thoro training in both the practice and the theory of costume designing. It includes costume sketching, costume draping, costume cutting, pattern cutting and grading, fashion illustrations and knowledge of dress materials. Pupils completing this course find opportunities as costume designers, costume drapers, graders, and fashion illustrators.

The course in Applied Textile Design covers all branches of woven and printed textile design. In addition to regular designing, students have an opportunity to place their designs on fabrics, and see the possibilities and limitations of the manufacturing operations. This enables them to draw their designs more intelligently. This course prepares people for positions as assistant designers in mills and textile houses.

Three types of instructors are employed—academic, technical and vocational teachers. The academic teacher is a regular high school instructor with a sympathetic attitude to vocational work. The technical instructor is the instructor of applied sciences, mathematics, and design. He is usually a graduate of a college-grade technical school with some textile experience. The vocational instructor is a practical man or woman with textile experience.

The hours and discipline of the vocational department approach those of business and industry. Pupils attend from nine to four; instructors are on duty until five o'clock.

The School has up-to-date equipment of textile machinery, including dye laboratory, testing laboratory, all varieties of looms and knitting machines, yarn manufacturing as well as finishing machines.

The only two academic subjects in the vocational courses during the last two years are English and American history. Thus, while the School aims to produce efficient workers, it shares with all schools the responsibility of training boys and girls to become useful, intelligent citizens, who know how to enjoy their leisure and obtain honest joy out of life, and be of sincere service to family, friends and country.

The importance of physical education is recognized, and time is provided for physical training and also organized athletics. Besides the regular classes, additional opportunity is afforded those students who find relaxation and aesthetic pleasure in music—vocal or instrumental—to attend musical clubs from four to five o'clock. Other clubs such as engineering, science, salesmanship, etc., are conducted during the same hours.

The Board of Regents of the University

of the State of New York has approved the above course of study and has recognized the school as a technical school of high-school grade. The New York Textile High school is to be found on the list of approved schools. Regents' diplomas are issued to those who pass the Regents' examinations in English, chemistry or physics, algebra or geometry and American history. Without much difficulty, it is possible for pupils of unusual ability to enter a higher technical school or college or college for advanced work in chemistry, dyeing or other textile courses. The higher institutions give credit for work given in the School.

In connection with the Textile High School there is conducted an evening textile (trade) school for men and women engaged in the textile business. The following unit courses are offered two evenings a week for thirty weeks: woolen and worsted fabrics, cotton converting, general cotton manufacturing, broad silk, ribbon manufacture, pile fabrics, plain and dobby weaving and loom fixing, Jacquard weaving and loom fixing, textile mathematics and accountancy, fabric analysis, general textiles, operating and repairing knitting machines, textile testing, interior decorating, hand decorated fabrics, textile chemistry, experimental dyeing, upholstery fabrics, mending knitted fabrics, textile design, fashion designing, costume design, costume draping, garment design, window draping, textiles for cutting up trade lace and embroidery design, textile millwrighting.

The evening trade classes are conducted somewhat differently from the day classes. The adults, who constitute the evening classes, work in the textile trades during the day and come to evening school with an intensely practical aim, so are unwilling to study systematically the whole subject of textiles as younger pupils in day school do. Evening classes

demand that the teacher lead directly to the specific things they want to know. To illustrate: Cotton converters are not interested in the mechanical principles of the loom, but do want to discuss the different methods of finishing cloth. Therefore, an evening trade school must offer short definite courses, each meeting some definite educational need of the trade. The instructors are usually practical men and women with considerable trade experience. Store and shop practice is used in applying the principles.

The students are classified, as far as possible, according to their trades. For instance, there is a class in broad silk fabrics, and another for narrow (ribbon) silk fabrics. The knitting machine operators form a class, and the salesmen of knitted fabrics another. The first class emphasizes the operation and repair of the machine, while the second brings out

selling points of the different knitted fabrics, and only such knowledge of the operation of the machines as is necessary to show the difficulties of manufacture which contribute to defects of the fabric.

In some respects these classes resemble quite definitely the organization of the old trade guilds of a few centuries ago. Each guild was formed for social intercourse and mental stimulus. Each trade had its own guild. The daily trade experience of each member became the property of all members. Today workmen have common trade experiences and interests. The evening students, grouped according to their occupations, have an opportunity for interchange of ideas and experiences. The teacher acts as director of the discussions and draws from the students their trade experiences, and thru the expression of these, solves the problems which arise.



COMMERCIAL ART ROOM, MILWAUKEE CONTINUATION SCHOOL

THE PRESENT STATUS OF INDUSTRIAL ARTS EDUCATION IN OUR ELEMENTARY SCHOOLS

III. METHODS OF OFFERING PROJECT-PROBLEM INSTRUCTION

A. H. EDGERTON, Chief of Vocational Information Division, Detroit, Michigan

INDUSTRIAL EXPERIENCES INVOLVE THREE CLOSELY RELATED ELEMENTS

AS previously indicated, varying degrees of emphasis are being given to the relative values of construction work and subject-matter by the six elementary grades in the school systems investigated. Nevertheless, with few exceptions, these 352 teachers report that they recognize the need for having the industrial arts experiences give some attention to each one of the following closely related elements:

- (1) *Motor expression* as a means of stimulating interest and mental activity, and of developing the muscles and senses to a reasonable degree (dexterity and discrimination);
- (2) *Information* regarding common industrial materials, processes, products, and developments to make pupils conscious of important divisions and relationships in their complex social environment;
- (3) *Situations* involving some understanding of the human factors (problems, conditions, and meanings) in the workaday world to encourage thoughtful appreciation of the possibilities for social service and individual expression.

In the teaching of industrial arts and related subjects, it is not uncommon to observe two widely divergent methods of learning in different elementary schools within the same school system, and even in different classrooms within the same building. Several of the grade and special teachers still follow the traditional method of assuming almost the entire responsibility for originating and announcing the object of the lesson, for making the plans, and for asking the pupils to assist in the execution of these. However, a large majority of the teachers concerned in this investigation report that, whenever possible, they encourage the pupils to set up purposes and to think out and develop plans on their own initiative.

PROJECT-PROBLEM METHOD OF LEARNING AND OF INDUSTRIAL ARTS INSTRUCTION

The project-problem method of learning is favored in principle by approximately 91 per cent of the special and regular elementary school teachers in the 141 school systems studied. This generally recognized method, which has received such wide interpretation recently, preferably involves the conscious setting up of specific purposes by the pupils, the making of plans to realize these purposes, the execution of the plans developed, and, if possible, the appraisal of the results obtained. As would be expected, a considerable difference of opinion exists among these teachers as to the amount of responsibility in purposing and planning which can be profitably transferred from the teachers to the pupils. On the other hand, nearly all of these teachers seriously believe that *industrial experiences should not merely limit pupils to either narrow or imposed tasks in handwork, but should offer sufficient opportunity for understanding and appreciating the worth of each activity and interest*, as well as for allowing some freedom in meeting the difficulties which arise in developing their own problems. While it is important that the pupils learn to follow directions and to conscientiously and accurately perform those tasks which are assigned to them, it is agreed that these *requirements should not be over-emphasized to the sacrifice of that development in initiative which makes for the proper expression of personality in either group or individual projects.*

Director H. G. Lull of the Kansas State Normal School, Emporia, Kansas, has suggested the following method of procedure in project teaching: "The procedure, of course, will vary with the nature of the project, yet there are certain

principles to be observed in the initiation of all projects. In the first place, the teacher should recognize the principle that the pupil's natural and relatively unhampered attack upon the lesson is an essential condition of successful learning. By natural attack is not meant the absence of definite purpose in the attack nor of guiding suggestions by the teacher, but it does imply the removal of authoritative directions and prescriptions into the background. In the second place, the teacher and the pupils must recognize the following requirements as absolutely essential in starting a project: First, the pupils must work as a social group, in closest co-operation with one another; second, they must find a worthy purpose and make plans to realize it; third, as far as possible, they should make a tentative outline of the project as a means of guiding the individuals of the class in their study; and fourth, they should distribute the work of the project among themselves, which is to be done in the following study (or work) period."⁶

It is encouraging to note that this form of purposeful teaching—call it whatever you may choose—not merely recognizes the existence of knowledge, thinking power, and skill, as such, but places a premium on their proper expression and use without neglecting the physiological and psychological factors of child development. When properly conducted with respect to the needs and interests of the boys and girls, who have much work in common at this age, group and personal planning and experimenting occupy an all-important place in the industrial arts projects and problems. Dr.

John Dewey has referred to these promising industrial activities as "ideal occasions for sense-training and discipline in thought." In continuing his discussion on "The Psychology of Occupations," he states: "Because the ordinary lessons in observation have no particular motive, there is no outlet beyond themselves. If there are no real needs and motives for doing a thing, sense-training becomes a mere gymnastic, and easily degenerates itself into knacks, or tricks, in observation. This means that it is a mere excitement of the sense organs. Normal thinking arises to meet some difficulty, but reflecting is the best way to overcome it. This should lead to planning for results to be reached. Certain steps and order are necessary."

BRIEF REPORTS ON SUCCESSFUL INDUSTRIAL ARTS PROJECTS AND PROBLEMS⁷

The following reports on the several types of successfully tried projects should prove suggestive to all teachers and administrators who have the responsibility for developing industrial arts activities in grades one to six, inclusive.

TYPES OF FIRST, SECOND, AND THIRD GRADE WORK

A PLAYHOUSE PROJECT—GRADE I

L. A. HERR

Supervisor of Elementary Industrial Arts
The Lincoln School, New York City

The first grade made a playhouse, using a piano box for a beginning. In planning the various features of the house, the class worked as a group. In executing the plans agreed upon in these group discussions, smaller groups chose different tasks. Freedom to shift from one type of work to another was encouraged so that every child gained many kinds of experience.

⁶Lull, H. G. "The Project Method of Learning," Kansas State Normal School publication; also see Kilpatrick and others. "Dangers and Difficulties of the Project Method and How to Overcome Them—A Symposium," Teachers College (Columbia University) Record, Vol. 22, pp. 283-322.

⁷It is appreciated that an elaboration of the details involved in each one of these units would be both interesting and profitable if the space could permit; however, the contributors have usually indicated that they will answer specific questions regarding their procedure and results.

Working in this way, a new floor was laid and paint was applied to the inside walls and ceiling. Measurements for a rug were taken and after its size had been determined and the material selected, weaving was begun on a hand-made loom. At first the work was done in the simplest way, neither heddle, batten, nor shuttle being used. After the pupil had gained some experience, these features were then added. While this work was in progress, another group made furniture consisting of four chairs and a table; another made draperies for the windows; still another made clay dishes to be used in future social functions to be held in the house.

Thus it will be seen that in the working out of this project and the different problems involved, the pupils gained firsthand experience with important building material, with clay as a potter's material, and with textile materials. While the dominant interest of the class was in the making and the using of these products, much information concerning the character and the qualities of the materials, as well as the methods of converting these usable articles, came as a by-product and formed a basis for further study.

BOOKS AND OTHER RECORDS—GRADE II

LEON LOVAL WINSLOW

State Department of Education, Albany, N. Y.
(Formerly in Charge of Industrial Arts at the
State Normal College, Bowling Green, Ohio)

In the second grade, a preliminary observation was made of our school books, involving the story of how we came to have books; tradition by word of mouth, covenants, the scroll, the folded sheet, laced sheets, the book; the bookbinder and the materials which he uses: paper, leather, cloth, thread, glue, paste; the tools necessary for simple book-making; pencil, ruler, scissors, and how they are used; and the care of books. Single-signature, flexible-covered pamphlets were made by each child to be used for picture study illustrations.⁸ Fastening together in an attractive way the drawings made in the course, and making a simple-line cover design with appropriate, lettered titles, also were satisfactorily accomplished by the pupils in this grade.

CORN PROJECT—GRADE II

NELLIE MAE LOCKHART

Washington School, Youngstown, Ohio

The purpose of this project was to show the children the great value of corn and to emphasize

the extent to which it is used in their everyday lives. We first compared the Indian methods of preparing corn with our modern methods. In order to accomplish this, some of the children ground corn between stones as the Indians did; while others brought in cornstalks and pictures of modern machinery. We then talked of the growth and care of corn. The pupils drew pictures of it and of the farmer at work. Some of the children who lived on farms made silos and told interesting stories of the preparation of corn for the silo.

Next, we studied the different products of corn and mounted many of them on a large chart. Samples of these products were brought in or, where these were not obtainable, the children read advertisements and mounted the pictures selected. Health posters and illustrated booklets comparing the food values of corn with other foods were made and taken home. After studying these products, we took up other uses of corn. To their surprise, they found they could make baskets, dolls, brooms, and the like from the husks. All thru this work, we tried to discover the time and interpret the value of the work done by farmers and manufacturers in preparing corn and its products, so that we as consumers might receive the benefits. In this way, the children found plenty of interesting material for reading, arithmetic, language, spelling, drawing, health talks, and constructive work.

Some of the activities displayed on the large class poster were as follows:

- | | |
|--------------------------|--------------------|
| 1. Dolls. | 10. Corn meal. |
| 2. Brooms. | 11. Mazola oils. |
| 3. Corn-cob pipes. | 12. Corn starch. |
| 4. Baskets. | 13. Corn flakes. |
| 5. Paper pulp. | 14. Chicken corn. |
| 6. Silos. | 15. Hominy. |
| 7. Health booklets. | 16. Popcorn. |
| 8. Karo syrup and candy. | 17. Popcorn balls. |
| 9. Corn bread. | |

We had expected to make candy from the corn syrup, to pop corn, and to make popcorn balls, but we lacked the necessary equipment at school.

POTTERY AND CHINAWARE—GRADE III

EFFIE ALEXANDER

Primary Supervisor, Adrian, Michigan

The teacher's general aim was to arouse or increase the interest of her third grade children in some of the common manufactured products in everyday use, and to show them how these things are the result of interesting industrial processes. It seemed desirable to lead the pupils to appreciate the skill and perseverance of the laborers, and the dependence of one worker upon others. In order

⁸Winslow, Leon L. Chapter 4 on "The Interpretation and Appreciation of Pictures" in bulletin on "Art and Industrial Arts," published by State Dept. of Education, Albany, N. Y.

to accomplish these ends, it was decided to consider how pottery was once made by hand and how it is made in the factories today. The pupils wished to learn how pottery is made in order to make bowls in which to put the bulbs that they were going to give their mothers. The illustrative material used in this study consisted of pictures of the potter's wheel, pictures of the potter at work, pictures of the kiln, pictures of pottery, pictures of Indian women decorating pottery, plaster-of-paris molds for castings, and Indian pottery and baskets.

The reference books used most freely were: *Elementary Industrial Arts*, by Leon L. Winslow; *Makers of Many Things*, by Eva March Tappan; Edson-Laing Readers, Book Three; *Indians of the Southwest*, by Pliny Goddard; and *The World Book*.

The general arrangement of the ten lessons, which were developed with interest and satisfactory results, was as follows:

- I. Story of the way in which the Indians made pottery.
Pictures of Indian pottery.
- II. How pottery is made today.
Picture of potter's wheels.
Pictures of potters at work.
Pictures of a kiln.
Showing plaster-of-paris molds.
- III. Cutting of silhouettes.
Study of designs from pictures, pottery, and baskets.
- IV. Making units and placing designs on silhouette.
- V. Beginning bowl: making bottom and putting on one coil.
- VI. Finishing building up bowl.
- VII. Smoothing bowl; getting it ready for decoration.
- VIII. Scratching design of border on bowl with a sharp nail.
- IX. Firing pottery out-of-doors in a large iron covered kettle.
- X. Smoothing and polishing bowl with sand-paper.

CONCURRENT RELATIONS OF SHOP AND ACADEMIC SUBJECTS—GRADE III

A. A. CAIN

Instructor Ethical Culture School,
New York City

At the Ethical Culture School frequent conferences occur between class and shop teachers for the comparison of notes, exchange of ideas, and rearrangement of outlined-plans of work, in order that shop projects and academic subjects may each be filled with the most vital interests of the other.

We endeavor to carry out this scheme of work from the kindergarten thru each of the grades. The following brief sketch of the work in several of the grades may illustrate the methods used.

In the kindergarten and primary grades, we strive to acquaint the children with a few simple tools and technicalities. As soon as they can hammer in a nail without its bending, and actually make a saw cut fairly straight, the class and shop teachers confer, after which there may be conferences with the children to discover the trend of interests. In the third grade, this year the children have decided to make additions to their furnishings in the way of flower boxes, folding stools, and a play house. The flower boxes have already been made in the shop. Their color scheme and decorations are being planned in the art periods. Other problems will develop in a similar way. The arithmetic of the grade is being applied to planning a zinc lining for the boxes. This requires application of the knowledge of addition for determining the length and width of the lining. (Also see fourth grade projects.)

TYPES OF FOURTH, FIFTH, AND SIXTH GRADE WORK

INDIVIDUAL PROJECTS—GRADE IV

CHARLES RICHARDS

Director of Manual Arts

Ethical Culture School, New York City

The Mechanic Arts Department, of the Ethical Culture School, is at present striving to get light on the problem of how best to gain in its shopwork those deep-seated, thoughtful, self-active interests, that the boys have shown in wireless work, aeroplane making, and all work which they have, themselves, adopted for the time being, as hobbies. It is well known that a hobby receives absorbing attention. What should we do to secure the same results in our regular shop work?

First came the suggestion that the pupils be allowed to choose their own individual projects regardless of any general class subject, rather than to have a common project chosen by the teacher. Then it was suggested that a subject like electricity or the boat-making industry be adopted and that, within the boundary of the subject, the pupil should have a free choice of a project.

For the past few years, the primary grades have had a very free choice of work. Last year in the fourth grade, we tried the second suggestion referred to above. The subject was the shipping industry. It was the bond that held the class in common. The boats resulting from this undertaking surprised us all. Every boy was anxious to build a boat according to his own idea. They

brought in ideas from models which they had seen in the parks and stores. They also delved into our shop library. Then in short talks we discussed, planned, and finally, in incredibly short time, produced boats of which the seventh or eighth grades could well be proud. Besides the boat, they gained spontaneously that vital subject-matter that tends toward an understanding and appreciation of progress in the world in which they live. The plan was pronounced a success by all, and is being repeated this year.

CLASS PROJECTS—GRADE IV

A. A. CAIN

Ethical Culture School, New York City

In grade four, at the Ethical Culture School, New York City, we strive, so far as is possible, to begin the class project work. For the past two years it has been boat study and construction. The history studied in the grade centers about the Greeks, the Norsemen, the Vikings and the explorers of various centuries. This offers a splendid chance to create interest in getting information on the various types of boats used by the peoples that are being studied and on the evolution of design in boat building. Written articles on the information found also are asked for in connection with the English work of this grade.

FOOD PROJECT—DIFFERENCE BETWEEN FLOURS—GRADE V

MRS. LOIS COFFEY-MOSSMAN

Instructor of Elementary Education
Teachers College, New York City

During the war a fifth grade group of children took some time in discussing the problem of getting adequate food. The discussion led to the problem of getting flour to make bread. Several children said they did not like rye and barley bread. One boy announced that his mother had quit making bread because she could not buy wheat flour, and she could not make good bread from the flour she could get. Out of these and similar remarks grew a feeling that there is a difference between wheat flour and other kinds. The teacher told them that she had read that there was a difference which could be found by washing each flour in water and comparing the results.

Accordingly four bowls of water were procured and also four pieces of cheese cloth. In one piece, double thickness, was placed a quantity of about two tablespoonfuls of wheat flour; the edges of the cloth were drawn together and secured with a rubber band, so that there was formed a small, loose bag of flour. Similarly rye, barley, and corn flour were placed in cheese cloth. These were

washed each in a separate bowl, by gently shaking back and forth in the water. Each of the four children undertook to care for one bag, washing it often during the day. The teacher washed a bag of wheat flour, at home, to be sure there would be some properly prepared.

The following morning the class met to examine the bags. Before opening them the children stated that they expected to find the following:

1. The wheat flour would be sticky because they had found it so in making flour and water paste.

2. The corn meal would be like wet sand. They could make no prophesy as to the barley and rye.

Then they proceeded to open the bags in this order: barley, rye, corn meal, and wheat. The rye and barley were slightly sticky, the water in each case being somewhat milky. The corn meal was like wet sand, not sticky. The wheat was a gray, sticky lump, and the water was very milky. The teacher then told them she had a bag of wheat flour she had washed at home, and opened it. The lump was more definite and stretched like rubber or chewing gum.

In response to the exclamations, "What is it?" it was developed that that was what was left after the starch was washed out into the water. The teacher supplied the name, gluten, telling them it is the protein of wheat.

Having found this difference, the class exchanged ideas until they agreed to the inferences that the gluten must do two things for the bread:

1. Keep it from crumbling by holding it together;
2. Hold in the gases developed in making the bread ready for baking, thus making the bread light.

To verify these inferences, they made two pans of corn bread, using the same recipe in each with the exception in the second instance of substituting, for half the corn meal, wheat flour. They baked the bread in a neighboring oven, the mixing having been done in the classroom.

On the basis of their inferences, they expected to find (1) the all-corn-meal bread thinner, because the gases had escaped and thus the batter was not lightened; (2) the all-corn-meal bread much more inclined to crumble.

When the bread was brought back to the room, the inferences were found to be correct, the bread containing wheat was twice as thick as the other and held together much more firmly.

ILLUSTRATIVE PROJECTS—GRADE V

CARRIE B. FRANCIS
Supervisor Industrial Arts
Indianapolis, Indiana

The 5A grade, at School Number 45, built a "Japanese Village," under the direction of Miss

Charlotte Thomas. This was based on their geography and correlated with art, spelling, composition, and arithmetic. The aim of this work was to give the children a means of expression that would develop their initiative and originality, and also acquaint them with the world around them thru their efforts to express their ideas and interests in concrete form.

From their homes and from the public library, these children brought books and pictures illustrating Japanese life and custom. They talked with people who had visited Japan, some of whom came to the school and told the class about Japan and its customs. The pupils decided the essential features of the village, which was to be staged on the sandtable. Various parts of the village were worked out as group problems. The children took the initiative in deciding what should be made, how it should be made, the proportions and the materials to be used. In several instances, different ways had to be tried before a successful one was worked out. Accuracy of representation, proportionate relation, color value, suitability of material, and artistic effects were some of the things for which the groups worked.

Entrances to the village were made attractive by the torii. The streets, which were ornamented with stone lanterns made of clay, were made life-like by the jinrikisha and the tea and vegetable peddlers with baskets hanging from their shoulders. These were made of wood and painted in characteristic colors. An interesting part of the village, leading to the temple, was an arbor covered with wisteria. The figure of Buddha was modelled in clay by a boy who had never before done any successful handwork. He asked that he might do all the modeling. The bridge over the canal was a troublesome problem, as a proper curve for the bridge seemed impossible. One day a boy brought a coat hanger from home, because he thought it had a curve that would give the proper construction to the bridge. From this, they worked out the curve of the bridge. One prominent feature of the village was the tea house decorated with lanterns and oriental curtains, which were made from small kindergarten splints. To find a material for the roof, which was pliable enough to be shaped and would also suggest tile, required some experimenting. Corrugated paper, painted and shellacked to stiffen it, was found to be most successful.

The teachers felt that the work vitalized the academic subjects; that the child's freedom of expression, his self-direction, and his responsibility for his work helped to develop interest, originality, initiative, and independence in the class work.

RELATED PROJECTS—GRADE V

GERTRUDE A. BEERS

Miami University, Oxford, Ohio

A fifth grade geography problem on the study of corn furnished a basis for a unit of work in food products manufactured from this cereal. In getting the material ready, each child made a booklet into which he pasted pictures from advertisements of every kind of corn product that could be found, such as cornstarch, oil, syrup, meal, breakfast-foods, etc. This booklet brought in the art problems of proper mounting of pictures and a cover design in which the corn plant was used as the motif.

It was next planned to make hominy. The class met out-of-doors to gather wood for a fire, which was to give the ashes for the lye. A cupful of sifted ashes to a quart of boiling water gave enough lye for the amount of corn used. The corn was boiled in the lye until the hulls loosened, then it was rubbed between cloths to take off the hulls. After being thoroly washed, the hulled corn was boiled until each grain was tender.

A party was now in order, so a committee was appointed to arrange the tables. The hominy was served with cream and sugar. Whittier's Corn Song, which had been memorized in the literature work, was recited at the beginning of the feast.

MAKING VASES OF CLAY—GRADE VI

MRS. LOIS COFFEY-MOSSMAN

Instructor of Elementary Education

Teachers College, New York City

It was a sixth grade class. A friend had brought in some flowers for the room—yellow nasturtiums. There was a nondescript collection of vases, red glass of inartistic shape, pottery of good design. There was one Chinese bowl, low and spreading, of the sort for pansies. In deciding which was the more suitable for the nasturtiums, there was not much difficulty in eliminating the red vase, or the low Chinese bowl. In the discussion of the various vases it became apparent that the children had little or no notion of what material the vases were made. Finally, some ventured that they thought the Chinese vase was made of clay.

This did not seem clear to many, so the teacher asked, "What is clay?" A number replied, "It's putty." Others thought it was wax and some suggested the word moldolith.

To clear their thinking, some native clay was brought into the classroom. The children were unconvinced that it was clay, asserting it was soft rock. Some was put into water and the effect noted. Similarly some *soft* clay was treated. Further, to bring out the notion, a piece of the

"rock" was rubbed between the fingers and the children saw it was really a powder. This brought out the teacher's knowledge of how the potter wedges his clay to make it more plastic by reducing the amount of air between the particles. The *Book of Knowledge* and encyclopedias were consulted, finding that clay was the result of "disintegration of feldspar." This needed explanation, so the story of the great glacial period was discussed.

Then one thoughtful child said he could not see how a bed of clay could be laid down free from rock and sand and gravel, since the glacier caused all this material to be mixed in the rushing waters flowing away. To answer, some clay, sand, pebbles, gravel, and rocks were put into a milk bottle with water. They were thoroly mixed into "muddy water." The children easily inferred that the rock and gravel would go to the bottom when the bottle had stood for a time. They were not sure what would "come down" next. In the morning distinct layers were to be seen below the clear water, the top layer being clay. The conclusion was drawn that a bed of clay is laid down only when water, muddy with clay, stands quiet for some time.

The bringing of clay into the room for answering these questions, together with the remarks made by the teacher about the plastic quality of clay as she had found it in making vases, furnished stimulus to lead some of the children to ask if they could try to make vases. The lack of zinc closets and the hot dry weather furnished much difficulty in handling the clay, which served to strengthen the notions of plasticity already brought out. Before the making had progressed far, the children began asking how the vase could be made so water would not soften it. This necessitated explanation of firing and the use of the kiln. The children wanted to know if they could fire their vases and glaze them. When green ware, biscuit ware, and glaze ware were clear terms, the children saw that more than one firing was necessary, and then they thought out the fact that the first firing needed to be the hottest. Soon the question came: "How does the man know how to control the heat?" A "cone" was brought to the room and its use explained. A trip was made to the kiln to take the green ware to be fired.

When planning for the glaze making, questions were numerous. "What makes the color?" "How do you put the design on?" The teacher had not felt it advisable to plan to mention underglaze decoration, but the question came and had to be answered. Then they wanted to know how the pattern is put on the sets of china so uniformly. This necessitated explaining the methods used in factories today. A trip was made to pottery shops

to see the wheel method by kick wheel and by electric power wheel.

The third method of making vases—by the use of plaster-of-Paris molds—was taken up in the classroom, using a borrowed mold. It was unfortunate that time did not permit making a mold. The use of the plaster-of-Paris mold involved noting the utilization of the property of plaster-of-Paris in absorbing water but rejecting the clay contents of the water.

When the vases were nearly ready to go to the kiln—that is, after the children became interested in expressing their ideas of beauty by impressing the clay, shaping it to their liking, the teacher read to them Henry Van Dyke's "A Handful of Clay." A little of the history came incidentally, but time prevented getting a clear notion of the contributions and characteristics of the various nations in the field of pottery.

It may be of interest to note that these children, so full of questions about the facts of pottery making, seemed quite uninterested in hearing the myth of Grandmother Kaolin read to them.

CLOTHING—GRADE VI

HELEN B. GOVER

Supervisor Elementary Industrial Arts
Passaic, New Jersey

Two of the most surprisingly successful projects come in the fifth and sixth years at Passaic. The first is a work-apron for school use, for which the patterns are measured and cut by each pupil. The sewing is done by machine. The second is a study of dyes. Various articles such as table-runners, neckties, aprons, and collars are the means of using some kind of textile decorations. Stenciling, tied-and-dyed work, wood-block printing, and embroidery call for the mixing and use of simple dyes, and the dyeing seems to form an unending source of delight on the experimental side, some rather interesting results having been obtained. In both of these problems the boys are more interested than the girls. The detailed work and study included:

I. *Subject-matter:*

A. Linen:

1. Industry in Europe and United States.
2. Processes of manufacture.
3. Advantages of linen over other materials.
4. Ways of adulterating linen.

B. Summary of study of four fibers:

1. Origin. 2. Uses. 3. Tests for presence in fabrics.

C. Dyes:

1. Sources of dyes in ancient times.
2. Vegetable dyes of colonial days.

- 3. Modern coal-tar dyes:
 - a. Comparison in price and quality with earlier dyes.
 - b. Problems of manufacture, German dyes, New American industry.
- 4. Ways of using in textiles:
 - a. Dying cloth in the piece.
 - b. Dying the yarn.
 - c. Printing patterns.
 - d. Earlier methods.

The important methods, which these teachers are stressing in approaching their so-called occupational studies, may be roughly classified as (1) *industrial*, (2) *neighborhood*, (3) *evolutionary*. Fig. III shows the number and per cent of teachers using each method of approach. The teachers who use (1), which is re-

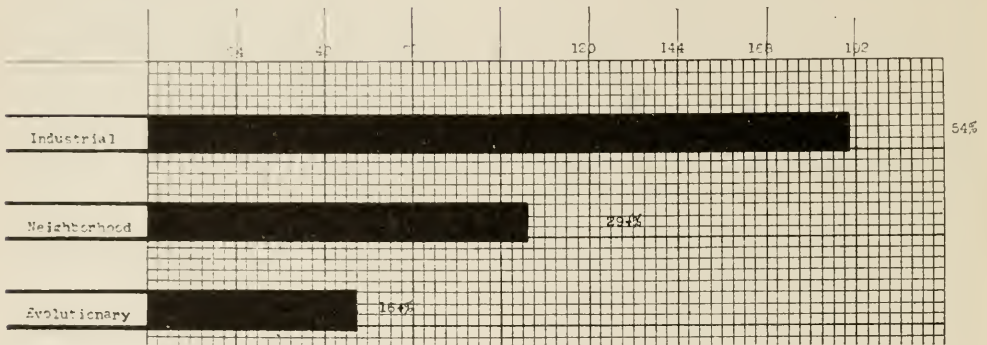

FIG. III. CHART SHOWING RELATIVE NUMBERS OF THESE 352 TEACHERS STRESSING EACH GENERAL METHOD OF APPROACH TO OCCUPATIONAL STUDIES.

- D. Rubber clothing:
 - 1. Crude rubber industry.
 - 2. Goodyear and the development of the rubber industry
- II. *Projects*:
 - A. Flax processes.
 - B. Testing cloth for various fibers by simpler methods.
 - C. Aprons, runners, and ties, tied and dyed in colonial fashion.
 - D. Chart of the rubber industry;
 - Collection of rubber to show development from sap to finished product.

VARIABILITY IN METHODS OF APPROACHING AND OFFERING INDUSTRIAL STUDIES

Although the method of approach to these industrial arts studies varies somewhat in the different school systems, *the majority of the teachers are now making specific attempts to establish identity between the school experiences and the occupational activities in everyday life.* In fact, over one-half of the teachers definitely stated that these reproduced forms of occupational work make strong appeals to the spontaneous interests of their elementary grade children.

ported more frequently than both of the other methods (in approximately 54 per cent of the cases), believe that the pupils should understand the industries of today and become appreciative users of products and service. The teachers who use (2), which is reported by over 29 per cent of the cases, insist that it is wrong to have the industrial studies take the pupils beyond the first-hand experiences of the immediate neighborhood or locality. While the teachers who use (3), which represents over 16 per cent of those questioned, urge that the proper appreciation of our industrial development can be realized only by having the pupils evolve the study from the simple activities of primitive man to the complexities of the present time.

In spite of this marked difference in opinion as to the best approach for the study of industrial arts, *94.7 per cent of these teachers are committed to giving some time to a general understanding of the materials, processes, and problems involved in*

changing raw materials into more valuable commercial products. Nearly all of them also state, with varying degrees of emphasis, that *the industrial work might well be considered as a means for enriching or vitalizing several of the other school subjects.*

A wide range of opinion likewise exists as to the period above the third grade when the work of boys and girls should be differentiated. In the 141 school systems investigated the practices vary decidedly, especially in the fifth and sixth grades. Nevertheless, most teachers seem anxious to offer types of group and individual experiences which will respect all levels of general and semi-specialized abilities. Nearly 41 per cent of the schools reporting state that the industrial arts work is offered in common to girls and boys thruout the first six elementary grades, implying that they are alike in more ways than they are different, altho the individual differences and capacities are usually considered in the projects and problems developed. Over 29 per cent of these schools offer separate courses in the sixth grade, several claiming that the natural differences in the interests and aptitudes of boys and girls, even of this age, warrant this differentiation. Approximately 22 per cent of the schools begin differentiating their industrial arts courses in the fifth grade. However, only 7 per cent of these schools make any attempt to separate boys and girls for this work below the fifth grade.

PREPARATION FOR AND SUPERVISION OF ELEMENTARY INDUSTRIAL ARTS INSTRUCTION

It is interesting to note that a large proportion—over 83 per cent—of the teachers represented by this investigation received no special training for giving instruction in industrial arts in their respective teacher-training institutions. On the other hand, it is encouraging that 127—or approximately 36 per cent of the

total 352 teachers—report that they have since voluntarily improved their classroom work by becoming familiar with the recent developments in elementary industrial arts instruction thru summer courses, extension classes, and the like.

The amount and kind of supervision which exist in connection with the industrial arts activities also differ materially. *Over 88 per cent of these school systems report that the supervision is merely nominal, so far as improvement of classroom instruction is concerned.* Teachers report the greatest help and supervisors the best results where the specialists take the attitude of assisting the grade teachers, who naturally should have the better knowledge of their pupils' qualities. While it seems that several of the grade teachers are not sufficiently interested in the actual construction work to develop their own technic along with the pupils, a greater number of those who were not prepared reported that they have gradually taken over the responsibilities of giving the entire instruction, thus relieving the specialists for other duties.

GENERAL SUMMARY

Finally, over two-thirds of the special teachers and supervisors of industrial arts questioned agree with the large number of classroom teachers that, in general, *the attendant skill and the related information acquired thru the elementary school period—for pupils ranging from approximately 6 to 11 years, inclusive—are to be justified mainly by resulting growth in thinking power and industrial intelligence.* In other words, they are, in the main, quite convinced that *situations, projects, and problems should provide the kinds and qualities of knowledge, thinking power, and skill (or dexterity) which will help pupils to establish those habits and attitudes that contribute most to their daily conduct as intelligent consumers and citizens.*

THE WESTERN ARTS ASSOCIATION

EMANUEL E. ERICSON

CINCINNATI, the "Queen City" on the "Beautiful Ohio," has again been the proud host of the Western Arts Association. Those who attended the convention there ten years ago no doubt visited the schools at that time, as we visited schools this time. They no doubt came away with the feeling that they had seen a modern school system from which they had received much inspiration and had learned many lessons just as this year's delegates feel that they have been fully repaid for their time and expenditures by their visit to the schools alone.

There is much evidence pointing to the fact that the Cincinnati schools are not lagging behind the best with reference either to buildings or quality of instruction given. Those who spent the most time in a study of the school system as a whole came away with an equal admiration for both of these aspects, while those who made their visits more casual received a lasting impression of the magnificent buildings and equipment. The reason for the effectiveness of the public schools of Cincinnati can well be understood from a statement by Superintendent B. J. Condon: "Cincinnati has freed its school board from political control, and its schools from tradition. We are looking toward the future."

Aside from the Ohio Mechanics Institute, in which the meetings were held, and which is worthy of all the pride the people of Cincinnati have in it, the East Side High School was the building most visited by the delegates. This building, of which a photograph appears on the first cover page, was pronounced ideal by all. The natural beauty of the landscape, the architectural individuality of the

building, the athletic field and the stadium building, the athletic field and the stadium, the large industrial building, and withal the wonderful equipment of the whole school are equally worthy of the admiration which was expressed.

Many other schools are worthy of special mention. Lack of space forbids a description of them at this time. Each school was obviously organized and operated for the sole purpose of serving the type of pupils in attendance. The visitors were impressed with a most striking flexibility of organization to fit local conditions, and yet, with the harmony which was evident thruout.

NATIONAL ART EMPHASIZED

Making art education practical was one of the strong notes of the convention. Speaking on the topic, "Industrial Art as a National Asset," Richard F. Bach, associate in industrial art, Metropolitan Museum of Art, New York City, made a strong plea for a distinctly national American design. He emphasized the need for a more general education in design, pointing out the fact that the buyer of goods must use the same type of thinking as the designer, and that, consequently, he needs the same type of art training as the one whose business it is to create the things which he is expected to buy.

The speaker stated that design has acquired a new meaning since the era of quantity production, and that the designer now needs a training which recognizes this fact. A mistake in design is more fatal when a large number of articles are to be turned out than if only one article is to be made. He emphasized the necessity of giving the designer

training in the shop where articles are made so that he may understand the process of manufacture.

Mr. Bach pointed out the fallacy of depending upon Europe for the design of American goods and of attaching particular value to an article because it carries an European name when we can easily obtain in America designs which much better fit our needs. We are selling our raw material to Europe at a low price and then buying finished articles at a high price. He gave figures to show that the United States sells 2,000 pounds of goods for \$100; England 1,000 pounds for \$100; France 400 pounds for \$100; and Germany only 30 pounds for the same sum. It is evident that this practice is depleting our resources and is supporting industrial art and skilled labor abroad.

Another fact brought out is that the United States has altogether eighteen schools of industrial art, while in Europe, Germany alone has fifty-nine such schools. This condition should prompt the business interests of our country to definite action so that more opportunity may be given to develop in America what we now pay high prices to obtain from Europe; namely, industrial design and skilled labor involved in working out this design.

RECOGNIZING THE INDIVIDUAL DIFFERENCES IN EDUCATION

Of more than usual interest to every educator present was an address on "The Education of the Abnormal Child" by Dr. Henry H. Goddard, director of the Bureau of Juvenile Research, Columbus, Ohio. In this address was emphasized the fact that, in the main, the people of today are following the traditions of previous years. The differences in human beings have not been recognized. The idea has been that education would overcome all individual differences.

Dr. Goddard based his discussion largely upon the data compiled from the intelligence tests which were given to 1,700,000 men in the military service during the World War, stating that the distribution of intelligence among these men would be representative of all our people. These tests show that there are 70 million people in the United States who have not enough capacity to finish high school. He showed that it is our duty to provide other means of education for these people and not try to force them to take academic work. "Some things that don't come out of books are educative," said the speaker. "The reasons why people of little capacity give us trouble is that we have made a botch of their education," was another significant statement.

Dr. Goddard stated further that we have tried to educate all the students to become college presidents, and, when they didn't follow our plan, they had no education for anything else. He said that the further down the scale of intelligence a person is, the more need there is for concrete education, and that "morons can get along in this world, provided they have some sort of an education." Again, "a Ford functions well according to its capacity, but you can't make it function like a Cadillac." That the public school has tried to do this was very plainly indicated. (Of course, we should like to assume that he was speaking of the academic regime, for surely no manual arts teacher has ever been guilty of such improprieties of conduct.)

That Dr. Goddard considers that woodwork is not a profitable subject to teach pupils of low mentality will be welcome news to many manual arts teachers who have been trying to make this fact understood by principals and superintendents. "No feeble-minded boy will ever make a living by making furniture,"

but "he might make good as assistant janitor," were statements in this connection.

MANUAL ARTS AND VOCATIONAL EDUCATION

Many of the members of the convention had looked forward to the discussion of topics pertaining to the relation of manual arts to vocational education. Speaking on the topic "To What Extent is the Distinction Between Manual Arts and Vocational Education Justifiable," Frank Leavitt, associate superintendent of schools, Pittsburgh, made it clear at the beginning, that he was not interested in a controversy over terms. Referring to the members of a junior orchestra composed of more than one hundred children of the grade schools of Cincinnati, whose musical program had preceded the speaker, he asked the question: "Who shall say whether the musical education of these children is vocational or general?" He then said that "whether a course is vocational or cultural depends wholly upon the use the students will make of the things they learn." While recognizing the worthy features of the Smith-Hughes Law, which has now been in operation for five years, the speaker stated that within his observation not a great number of so-called vocational students have gone into the vocations which they have studied. In the light of this experience the question whether it is justifiable to separate the classes and call one vocational education and the other manual arts takes on a deeper significance. That we can not predetermine the future action of boys and girls, but that *the duty of the schools is to give a varied experience to a large number, rather than a specialized experience to a few*, was strongly emphasized.

That there are some subjects which are vocational for some students and others which have larger vocational value for

other students was again brought out by J. D. Diehl, assistant principal, Boys' Technical High School, Milwaukee, who spoke on the topic "Keeping the Door of Opportunity Ajar." To show how varied the vocational applications of a subject may be, he told of a dentist in Chicago who had recently explained to him in great detail how he benefits daily in his dental work from a course in pattern making which he took in high school. Boys should not be kept on a trade in the junior-high school, however, according to Mr. Diehl, but should have the opportunity to shift about from one subject to another and thus the door of vocational opportunity would be kept open to him.

THE JUNIOR HIGH SCHOOL

As might be expected, the junior high school came up for discussion. Frank J. Pickell, assistant superintendent of schools, Cleveland, whose topic was "Manual Arts in the Junior High School," treated this subject somewhat from the administrator's viewpoint. He asked the pointed question: "Why do we put manual arts in the junior high school?" Every teacher of this subject in the junior high school should certainly be ready to answer this question. Mr. Pickell went on to show the difference in cost between the manual arts work and the academic work, pointing out that manual arts subjects must be justified on their merit or be removed.

Two statements were given in justification of the manual arts: (1) the manual arts in the junior high are justified because they help to explore children's talents and help to broaden their education, and (2) they will help to make all the children of all the people appreciate all the problems of the people. The second statement carried out in more detail would mean that the boy

who later is to become the employer or manager will better understand his employees because he has rubbed elbows with them in the school shop where their problems were common ones. That some quantity production work should be done in the junior high school, and that this work should tie up with as many different departments as possible, was another conviction expressed. A book which had been written and printed by the public school pupils of Cleveland, was exhibited as a result of such correlated activities in the school.

BUSINESS MEETING

At the final business meeting of the Convention the following resolution was unanimously adopted:

WHEREAS, the development of art in its relation to industry is a matter of National importance,

Be it resolved that this Association express its commendation of the attitude of the United States Bureau of Education toward the movement for the promotion of art in industry and for its publication of the pamphlet *Industrial Art as a National Asset*, and that this Association feverently hopes

that the Bureau may be provided with funds which will enable it to occupy its proper position of leadership in this movement for art education which is essential to the best future development of American industry.

The following officers were elected for the coming year:

President, Miss H. Estelle Hayden, supervisor of art, Des Moines, Iowa.

Vice-President, George H. Hargitt, Teacher of Manual Arts, St. Louis, Mo.

Secretary-Treasurer, L. R. Abbott, supervisor of industrial arts, Grand Rapids, Mich.

Carl T. Cotter, the retiring president, was elected to the Council.

Resolutions of thanks and appreciation were unanimously adopted, mentioning especially the efficient work done during the past year by the president and the secretary-treasurer of the Association, and by William H. Vogel, chairman of the local committee and his immediate co-workers, Miss Charlotte M. Ullrich, Charles Boebinger and Elmer Christy.

We must not forget that machine-made industrial arts can be beautiful. They must be beautiful if American manufacturers are to win supremacy or even hold their own, in the international competition which is following the war. We have a great opportunity but that alone does not mean success. When the choice is between two manufactured articles equally well made, at the same price, it is fairly safe to say that preference will be given by people of taste to the one which has in addition the quality of beauty. It is this plus quality of artistic worth which we must have more and more abundant in our American manufactures.

—JOSEPH BRECK.



EDITORIAL REVIEW FOR THE MONTH

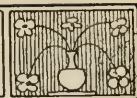

DEATH OF WILLIAM HAWLEY SMITH

ON THE eighth of May, at his home in Peoria, William Hawley Smith, author of "All the Children of All the People," passed out of this life. He was seventy-seven years old. Ever since an attack of influenza two years ago his health has gradually failed. Six weeks ago his condition became serious.

While Mr. Smith's activities were not, strictly speaking, in the particular field of educational effort which this Magazine represents, he contributed much to it, because he was one of the men who helped to create it and he has always been enthusiastic over its development. It is a remarkable fact, however, that while Mr. Smith rejoiced in the early efforts to teach by means of handwork—to learn by doing, in the school as well as in real life—he was not satisfied with many of the earlier applications of that principle because he saw more clearly than most of us that any system that treated all children just alike would not be satisfactory. He was constantly preaching flexibility of organization to meet individual needs. Probably the most fundamental idea that he contributed to education was what he termed his "born short and born long" theory.

On account of his remarkable insight into human nature, and consequently into problems of education, he was able to point out facts of vital importance before they were demonstrated by the present generation of scientists. It is the old story of seer and scientist: the seer declares the new truth and the scientist comes along with his method and apparatus and verifies it. William Hawley Smith was, indeed, an educational seer and more than most other men, also, he

had the ability to present what he saw in popular and convincing form.

About 1879, when Mr. Smith was superintendent of schools in Mc Lean County, Illinois, he wrote a story entitled "Dick" for Scribner's magazine which attracted considerable attention. In 1883 his friend, John W. Cook, then editor of the Illinois Schoolmaster, asked Mr. Smith to write an educational story. The result was "The Evolution of Dodd," which has never ceased to be popular, its sale in book form having passed the million mark. This book, together with many minor writings and two or three other books outside the educational field, prepared him for his greatest contribution to educational literature, "All the Children of All the People," which appeared in 1912.

But it is impossible for those who knew Mr. Smith at all well to think of him as an educator in any narrow sense. His versatility, as well as his insight into human nature, was remarkable. Preacher of liberal Christianity; a long-time investigator of the science of psychology, especially in its relation to subnormals; a humorist and entertainer of rare ability, having won his reputation in several years of traveling with Bill Nye; a literary leader in his own community, and the friend of Walt Whitman, James Whitcomb Riley, Bob Burdette and also of a score of literary lights of a later day; a neighbor with open house to every congenial spirit; a friend of anyone who needed advice and inspiration, often giving himself more freely than his strength would warrant; and always a teacher in the broader significance of that term.

Many of us in Peoria will miss his

"dropping in" and his delightful telephone calls. Whenever he caught a new idea or heard a good story he could not keep it to himself; he had to share it with others. I recall a characteristic incident:

One evening I was sitting in my study and the telephone rang. I answered, and the familiar response came "William Hawley." This was his message: "I found something today, I want to tell you. It's a darkey's prayer: 'O Lord, we know mighty little. You know our necessities. Bless us to suit yourself. Amen.' What do you think of that? Didn't he get it about all in?"

This is the kind of treats he gave his friends, and one of his closest friends says that she never heard Mr. Smith say an unkind word about anyone. Apparently the good he found in people outweighed the bad, or, more likely, the bounds of his sympathy were never reached.

Yes, William Hawley Smith has passed on, but his influence is as great and as far-reaching as in his most active days when he was entertaining thousands of people with good humor that was also good preaching in company with Bill Nye.

ANOTHER POINT OF VIEW

AS IS well-known to the readers of these pages, it is the policy of this Magazine to encourage real discussion of debatable topics in its field. The editor, whose duty it is to accept or reject contributions, always welcomes different viewpoints. The discussion on the "Project-Problem" in the May issue is an evidence of this fact. This same policy applies to contributions from readers and from members of the editorial staff alike.

The following reaction to Mr. Dean's discussion of "Present Status of Part-Time Schools" in our May issue is from

a member of the editorial staff—Frank M. Leavitt, associate superintendent of public schools, Pittsburgh, Pa.

THE CONTINUATION SCHOOL

WE FIND it extremely difficult to get Mr. Dean's "Point of View" as revealed in the May issue of the *Manual Training Magazine* and we hope that our readers will not receive the impression that his opinions are shared by the full editorial staff.

It seems to us that Mr. Dean's article is decidedly inimical to the continuation school movement for the following reasons.

First, it furnishes arguments, even if spurious ones, to those employers who object to the continuation school program because it interrupts their own plans for the employment of juvenile workers.

Second, it will tend to support the feeling of indifference toward the continuation school which is now held by so many of the teachers in the regular schools. It is most desirable that these teachers be brought to understand the continuation school in order that they may so prepare those children who leave their classes to go to work that they will make the best possible use of the opportunities offered for continued education.

Third, it will tend to confuse and mislead that large body of students of vocational education who, in scores of universities, are studying the problems of part-time education, and will lead them to minimize the significance of the tremendous progress which this type of education has made during the past decade.

Fourth, it may even bring something of discouragement to the teachers in the continuation schools who, working in a pioneer situation, are struggling to-

ward a fuller and better interpretation of the part-time plans.

While it is difficult for us to understand just what Mr. Dean is attempting to accomplish by means of his article, it would seem to indicate that he wishes to convince his readers of the essential truth of the following statements:—

First, that the principle of the continuation school is wrong or, at least, that it is inappropriate to the ideals of the American school system as now administered.

Second, that the proposition of the further education of working children is so difficult to understand that, had it not been for Mr. Cooley and Mr. Evans, there would have been no continuation schools in the United States which could be rated as even "fair-to-middling."

Third, that the movement is headed in the wrong direction and is likely soon "to go to the jolly bow-wows" because there are so few people connected with the movement who have insight regarding its possibilities and energy enough to carry out progressive policies.

Fourth, he seems to give the impression that four hours a week only are allowed for the continuation school, apparently ignoring the fact that many such schools have eight hours a week—practically one-third as much time as is afforded by the elementary school.

In his remarkable discussion, he seems to have set himself squarely at variance with the two men whom he is pleased to recognize as being the only men in the country who can be considered authorities on the continuation school movement. We doubt seriously whether either Mr. Evans or Mr. Cooley can subscribe wholeheartedly to the implication of Mr. Dean's article that the continuation schools on the whole are failing and are in danger of being given up entirely.

The course of study which Mr. Dean

outlines for boys and girls between fourteen and sixteen is practically identical with the program which has been followed for two or three years in certain continuation schools and which is now the confessed program of at least one entire state, a fact which Mr. Dean seems to have overlooked. The article



D. J. MAC DONALD

makes several other statements which would have been more accurate two or three years ago. It seems to us, on the whole, that Mr. Dean is not justified in making such sweeping and dogmatic statements regarding the practices in continuation schools.

—FRANK M. LEAVITT.

PROFESSOR MAC DONALD TO GO TO THE OHIO STATE UNIVERSITY

PROFESSOR D. J. MacDONALD of the University of Cincinnati has just been called to the Ohio State University at Columbus, where he will take charge of a new department to be known as the Vocational and Commercial Education Department. From this center all the teacher-training work of the state in the field of trades, industries and commerce

will be conducted, with the exception of what is done in "the Cleveland territory," which includes Akron, Youngstown and other sizeable cities in the north-eastern part of the state. This means, then, that Professor MacDonald will continue to work in the Cincinnati district but will greatly enlarge his field of effort and the scope of his activities, and have his headquarters at the State University. He is looking forward to starting some genuine research work in the field of industrial education which will yield practical results in teaching. The training of teachers of commercial subjects also presents a large problem that will require its full share of his attention.

The promotion of Professor MacDonald was recognized by his co-workers in Cincinnati in a most appropriate way a few days ago when he came to the end of his year's work in training leaders for foremanship classes. The representatives of the twenty-three co-operating machine tool plants presented him with a very fine traveling bag and their good wishes for success in the larger work in prospect.

Professor MacDonald's record is a very consistent one and fairly typical of that of men in similar positions. After attending a district school in Pureau

County, Illinois, he taught for four-and-a-half years in the same county. Then he completed his academic course and his college course, receiving his A. B. degree at Leander Clark College in Iowa in 1905. The following year he took his Master's degree at the University of Iowa, and won a fellowship in education. For two years more he was a graduate student in education and psychology at Iowa.

After teaching mathematics for a year at Muscatine, Iowa, he went to the University of Colorado, where he was instructor in education and psychology and assistant inspector of high schools. From there he went to Teachers College, Columbia University where he was granted a scholarship in School Administration for the year 1911-12.

Then followed a year of teaching at Cornell College, Iowa, four years as head of the pedagogical work and instructor in evening schools for training vocational teachers at the State Normal School at Buffalo, one year as associate professor of vocational education, Indiana University, and the last four years as professor of Vocational Education at the University of Cincinnati.

He will begin his work at the Ohio State University on the first of July.

Skilled workers are the greatest asset for the creation of wealth that any nation possesses.

—JOHN J. TIGERT.

A POINT OF VIEW

THE ROCHESTER CONVENTION AND THE ROCHESTER SCHOOLS

THE steam car is filled with old men. The train speeds past old houses. The cities have old names: Hamburg, Hudson, Troy, Oneida, and Syracuse. The soil is old. The hills are old. Only the water is new in that ancient river, Hendrick Hudson, and only the children are new on the old streets.

We pass old school houses with old ideas and new school houses with old ideas. The discredited Erie Canal is on our left. A new canal, little used, criss-crosses our railed track. The Empire State Express, snail-like, crawls, now, as always, thru the same main street of Syracuse.

Along the line breweries have been Volsteded, foundries Pittsburghed, brick yards concretized. A state alive in spots and dead elsewhere.

New ideas of Beechnut products at Canojoharie, Library Bureau at Ilion, Franklin autos at Syracuse, General Electric at Schenectady. New York the City of Myriad Lights behind, Rochester a City of Vision ahead. The occasion is the thirteenth Convention of the Eastern Arts Association. The purpose is friends and ideas.

I knew it was to be a good convention. Reagle of Montclair, Mathewson of Jersey City, Barker of Rochester, and the 1923 President, Miss Bachelor of Hartford laid the foundation by an attractive program, extensive advertising, close followup and adequate local arrangements.

But I am writing of Rochester—A City of Vision. I can get a town's number as soon as I step off the train or enter its hotel. The hotel, streets, and station of a city collectively give the coefficient of efficiency of its school system.

Rochester! Home and work-place of George Eastman who has not only kodaked the country with his cameras but has kodakized his earnings into the Eastman School of Music, Mechanics Institute, Rochester University, and (under the name of Mr. Smith) the Massachusetts Institute of Technology. A man of millions who is trying to die poor in wealth and rich in reputation. One of the greatest business educators in America.

"Picture Ahead" is his highways and by-ways slogan. Picture ahead indeed! as I anticipate the meeting in this progressive city. All in all, Rochester has a wonderful school system. It is a city of fine civic spirit. It has had, and has, unusual school men and women: Carroll, Miss Harris, Fletcher, Moulthorp, Weet, Glass, Miss Lucas, Miss Benedict—and James Barker. It has its Mechanics Institute with its memories of Murray, Gibson, Barker, and Farnum.

It was an Eskimo Pie meeting (that little oblong block of ice cream covered with chocolate is paying to its inventor a weekly royalty of \$30,000 on the basis of five cents a dozen cakes. "Cover ice cream with chocolate!" Ridiculous, the inventor was told. Chocolate will not stick to ice cream.) In other words the meeting had novelty, perfect assimilation of two things which once did not stick, i. e., art and manual training, palatableness and calories.

Eastern Arts Association! Manual, industrial, household, and graphic, and all the other arts including the art of expressing a professional spirit. The attendance was large. The luncheons and dinners of class and territorial groups were many. The commercial exhibits seemed to me to lack punch. The professional exhibits on the art side were

high in quality. On the manual side there was a lack in quantity (perhaps because no exhibit can show the real product, i. e. boys and girls; perhaps because the day of the "model" having passed, it is impossible to send by express the "project").

As to the program itself, I will not discuss it. It was a good one, however, and extremely well supported in the various sectional meetings by good attendance and new ideas. The whole spirit of the meeting in one respect was unlike Eskimo Pie. The inventor of this pie states "it is possible to leave a bar exposed in a warm room for as long as thirty minutes before it will melt." I have seen Eastern Arts and manual training meetings in the past where one could expose a story or an idea for 90 minutes and it wouldn't even start to melt. The Eastern groups are catching some of the virility and humaneness of the Western groups. Keep it up!

I visited several schools. The part-time school has great merit. The school shows real organization and a teaching method worthy of imitation. The work for commercial people was really rather extraordinary. The work in the two junior high schools attracted a great deal of attention and deserved it. If there is anything in school work which requires a real man or woman as administrative head or teacher it is in these "spirit of adolescent youth" schools. I shall not attempt to describe them. Producing their courses of study and outlines of subject-matter would not tell the story. The spirit of the project method, extra-mural activities, clubs (Washington Junior High has 65 of these clubs), hall exercises, bulletin board notices, community associations, gang groupings, etc., etc.—it is these which make a *junior* high school instead of a junior *high* school. (Congratulations for

Boston for putting in the discard the term junior high school and for substituting intermediate or middle school). They are indeed, middle schools—standing between the kidlet that was and youth that is to be. "The twelve to fifteen year old boy acts like a kid but wants to be treated as a man" is the first principle to lay down before you build your junior high school course of study. The second principle is to watch the pedagogy of the Boy and Girl Scout movement and "go and do likewise."

The Rochester Shop School has greatly improved. It was one of the first schools in the country of the vocational order. The electrical work appealed to me greatly. I suspect, because it is so poorly done in so many places. I wondered while there if the school was not moving in the direction of a secondary school. Its above-the-average work in science, drawing, and mathematics, coupled with the fact that it takes only graduation from the eighth grade, gives it the standing of high school grade. The school showed a better quality of correlation and shop product than apparently is possible in a regular high school with an industrial course where the course is *correlated with credits* for high school diploma rather than correlated with industry. Principal Bennett is a student, worker, and opportunist.

But it is of the Prevocational School for Boys, I would write. This is the school which exhibited some very superior furniture at the Atlantic City meeting of the N. E. A. Its principal is F. E. E. Raab who has written a manual on the "Manufacture of a Teacher's Flat Top Desk" for the American Woodworking Machinery Company. I well recall Raab when he was a teacher of woodwork in the old Rochester Shop School which was one of the first vocational schools in the country organized on a state aided

basis. He had a group of human odds and ends as the vocational schools had in those days and do even now. I had expected to see the usual layout of machinery and tools and the customary models and projects. But Raab was different. Being a practical furniture worker and business man he assumed that he had been engaged to turn out furniture and workers in furniture. He therefore organized his shop on a productive basis by arranging his machines, lumber rack, benches, and floor space to produce and to teach. He had hot and fresh glue, dry lumber, sharp tools, and system. Not knowing any better he started the boys to making desks for teachers, book cases for library books and cabinets for school rooms. Making them in numbers, he naturally made them as in his own business. Having required in the past that workmen do a good job from start to finish he naturally followed the same course in the school. The result was not only a large quantity of equipment for the schools but a quality of workmanship which had no equal in any school in America.

When the school changed over from a school of mental dubs to a school of high school calibre, Raab and the boys did similar good work. Some visitors at the time said that the good work was due to the high type of pupil.

Now Raab is principal of this "pre-vocational school." It is misnamed or rather perhaps, I should say, Raab has deliberately misunderstood what a "pre-vocational school" should be. He ought to be making excuses and say "I cannot do good work because I am in a pre-vocational school and have only boys with me who have a sixth grade or less education." And that is all that he has nowadays—the discards, misfits, and those

who would otherwise be in the human scrap heap. But Raab as of old, seems to assume that he has to make desks and boys regardless of the mental quality of his material. I believe that he is making better desks than ever. I know he is making better boys than ever because they grin when he goes thru the shops. Write to the A. W. W. Machinery Company to see how he does it.

The training problem for the mentally below par is an interesting and vital one. Shall we give them gardening, chair caning, cabinet work, cobbling, and other trades of the craft order or shall we offer training in work which may become, when one is skilled, practically automatic? Raab hopes to open a shop in button turning, a trade which would fall in the second group. At the same time both of us are puzzled by the fact that mentally dull boys are doing as good work in such skilled trades as printing and sheet-metal work, as those who are mentally sound.

James F. Barker, assistant superintendent of schools in charge of Vocational Activities, and I judge of all other activities which no one else wants, at the convention was "Jimmie" as Mathewson was "Frank" and Reagle was "Major." They were a fine trio. The Eastern Arts Association was near death until these fellows got out the pulmotor and pumped oxygen into the patient. The New Jersey crowd are a lively group. They dominated the meeting on the foreign soil of New York.

May we trust in Providence (R. I.) for the next meeting with Rose as host, Bachelor as helmswoman and Mathewson as the man "who had rather be secretary of the E. A. A. than anything else" and we like him all the more for it.

—ARTHUR DEAN.

WASHINGTON CORRESPONDENCE

ARMY TRAINING PLANS

IT IS expected that the summer of 1922 will be "the liveliest season for the regular army, the organized reserves, and the national guard in time of peace in this country." A program of intensive military and vocational training has been projected, covering practically all branches of the service and all types of vocational activity carried on in the army.

The plans which have been prepared contemplate the training of approximately 30,000 citizen soldiers in a number of selected centers, including representatives of the national guard, reserve troops, civilians, and the reserve officers' training corps. The extent to which these plans can be carried out depends on the action taken by Congress on measures now pending, which will fix the size of the appropriations and the personnel of the army for the coming fiscal year. Regardless of the limits which may be set, however, the Department has determined to go as far as possible in offering opportunities for training to civilians.

VOCATIONAL TRAINING CENTERS

DURING the period from June 15 to July 27 training camps will be conducted as follows: infantry officers, at Edgewood Arsenal; engineers, at Camp Humphreys, Virginia; coast artillery, at Fort Monroe, Virginia; motor transportation officers, at Camp Holabird, Maryland; ordnance officers, at Aberdeen Proving Grounds, Maryland; medical officers, at Carlisle Barracks.

From July 27 to August 26 civilian training for residents of the Third Corps Area, which includes Pennsylvania, Maryland, Virginia, and the District of Columbia, will be conducted as follows: infantry, cavalry, field artillery, and medical corps, to the number of about 2,000, at Camp

Meade, Maryland; engineering, at Camp Humphreys, Virginia; air service, at Langley Field, Virginia; coast artillery, at Fort Monroe, Virginia. Similar provision will be made in the other corps areas.

Units of the national guard in the various states will be accommodated at convenient points for shorter periods, with opportunity for drill and appropriate field maneuvers.



JOHN C. WRIGHT, who has just been appointed director of the Federal Board of Vocational Education, Washington, D. C., is a native of Indiana, altho for nearly 20 years he has been a resident of Kansas City, Mo. He is a graduate of the State Normal School, Emporia, Kansas, and also of the University of Missouri, with the B. S. and M. A. Degrees from the latter. He began teaching in a rural school in Kansas, later serving as principal and superintendent of schools. From 1904 to 1918 he was connected with the public schools of Kansas City, Mo., as high school teacher and principal, and for five years as director of vocational education. He came to the Federal Board at the time of its organization in 1917, on leave of absence from Kansas City for the first year, and during the past three years has served as chief of the Trade and Industrial Education Service.

STUDY OF OCCUPATIONS

THE vocational training program of the army is being developed in close relation to conditions and demands of civil life, with the end in view of making as much as possible of the training which the individual receives in the army function outside when he leaves active military service. Certain occupations are practically the same in the army and in civil



JOHN A. RANDALL, newly elected president of Mechanics Institute, Rochester, N. Y., is a native of Maine, and a graduate of Wesleyan University, Middletown, Conn. After teaching one year in Cheltenham Military Academy, he went to Pratt Institute, Brooklyn, N. Y., where he served for eleven years, being promoted a number of times until he reached a position as head of a department. He then became service engineer for a large corporation in Toledo, Ohio, from which position he was brought to Washington, shortly after the outbreak of the war, to be the secretary of the advisory board of what is now the Operations and Training Division of the General Staff.

life, and in certain others the common elements constitute a considerable proportion of the whole. It has been deemed desirable, therefore, to adopt uniform, or

at least consistent, terminology, trade processes and methods, and methods of instruction, so far as possible.

The army maintains a civilian advisory board, with Dr. Charles R. Mann as chairman, and a staff of experts representing extensive experience in civilian industrial and manufacturing establishments, as well as in public and private institutions conducting various types of vocational education, especially industrial education. This vocational education staff has been endeavoring to make available to the army the experience of the vocational education movement in civil life. Some opposition and some scepticism have had to be met, since army traditions are deep-rooted and influential.

Certain definite steps have been taken, however, and the military authorities now recognize the significance of civilian vocational training in the building up of an efficient army, and much progress is being made in the application to army requirements. Dr. Mann talked very interestingly, a few days ago, of a series of conferences with representatives of the various branches of the service, which have for their object agreement upon a statement of the minimum specifications for the occupations required.

The first step was to define the qualifications and duties of the basic private which are common to all services, and then the additional items applicable to each service, respectively. Three classes of private are defined: combat, limited service A, limited service B.

The next step was to take up the various trades, such as chauffeur, plumber, and so on. For example, the *skill* needed for the discharge of the duties of the "basic chauffeur" was tentatively stated to be as follows: in addition to the requirements of the basic private, demonstrated ability to: inspect, care for, and clean his vehicle; drive a truck or pas-

senger car; make minor emergency repairs; read and use a road map; determine whether his vehicle is operating normally. In addition to the *knowledge* required of a basic private, he should be able to demonstrate a working knowledge of: the principal parts of his vehicle, and their functions; general traffic regulations, and rules of the road; effects on parts of mistreatment or neglect.

Later studies will determine special additional requirements adapted to the duties of chauffeurs assigned to various branches of the service. So far as possible, all of these statements are drafted in terms of the related civilian occupations.

IMPORTANT CHANGES IN PERSONNEL.

TWO important changes are to be reported this month. On Monday, April 10th, the Federal Board for Vocational Education appointed J. C. Wright to the position of director, to succeed Lewis H. Carris, who resigned in January. On Monday, April 3d, the Board of Trustees of Mechanics Institute, Rochester, New York, elected J. A. Randall to the position of president, to succeed Mr. Farnum who resigned several months ago to return to Massachusetts. Mr. Randall will continue for the present as secretary of the War Department advisory board, taking active charge as president of Mechanics Institute in September.

—WILLIAM T. BAWDEN.

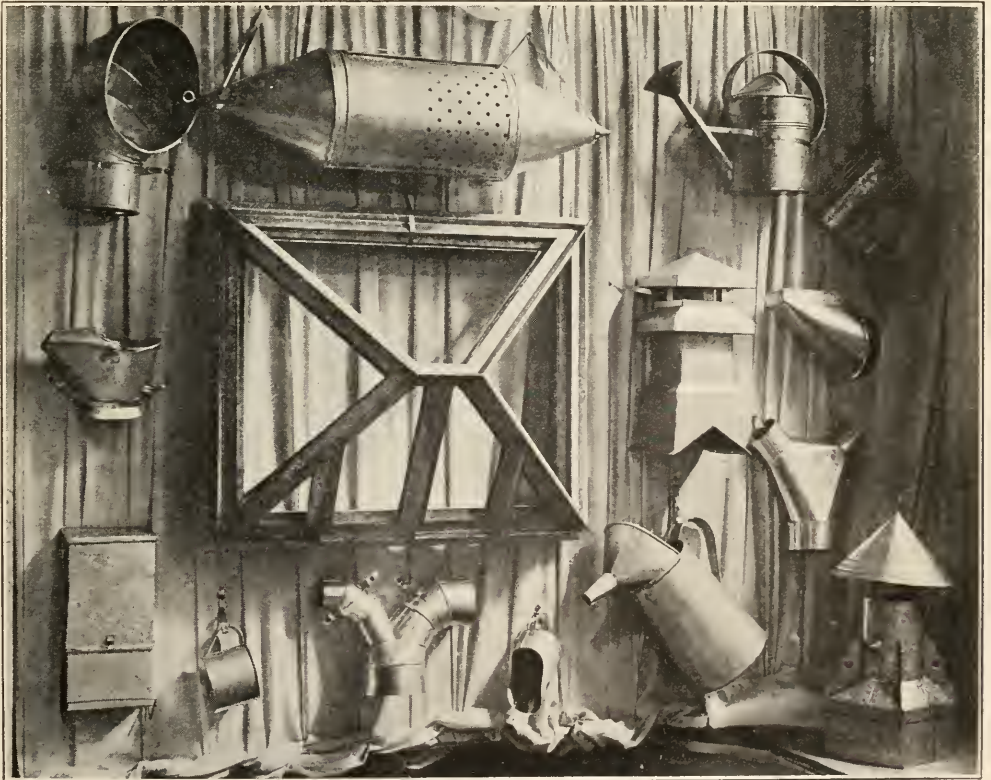
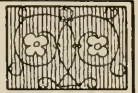

EXHIBIT OF SHEET-METAL WORK, MILWAUKEE CONTINUATION SCHOOL, SHOWN AT CONVENTION OF VOCATIONAL EDUCATION ASSOCIATION OF THE MIDDLE WEST.



PROJECTS, PROBLEMS AND NOTES



EXAMINATION IN FORGE PRACTICE

FIRST SEMESTER, 1921-22

Given to Junior College Students at Grand Rapids, Michigan by Griffith E. Owen, Time allowed, 3 hours.

I. *Welding.*

- (a) Name and illustrate the modern methods of welding.
- (b) Sketch and describe the common welds (scarfs).
- (c) Sketch and describe the special welds (scarfs).

II

- (a) Why do we use a flux in welding?
- (b) What is the method of using flux?
- (c) What is the scarf?
- (d) What precautions are necessary to prevent the formation of scale?
- (e) What difference is there between the welding characteristics of steel and of iron?

III. *Materials.*

- (a) What are the materials most commonly used in forging?
- (b) Describe each of the above.
- (c) Illustrate the several methods used for testing the materials.
- (d) Describe the conditions necessary for building and keeping a good fire for (1) welding (2) high-speed steel work.
- (e) Name and explain the methods and necessities of case hardening in iron and soft steel.

IV. *Carbon Tool Steel.*

- (a) What is meant by the refining heat?
- (b) What is meant by the recalcrescent condition of heated steel?
- (c) (1) What are the disadvantages of using carbon tool steel for machine tools?
(2) The advantages?

V.

- (a) Name the two laws to have in mind while hardening steel.
- (b) Name the colors that come to polished steel during the hardening process.
- (c) Explain the operations of (1) hardening (2) tempering.
- (d) How would you harden a reamer?
- (e) How would you harden a milling cutter?
- (f) Name the methods of annealing carbon tool steel.

VI. *Treatment of high-speed steel.*

- (a) How should high-speed steel be heated?

- (b) How should high-speed steel be cut to required length.

- (c) How do we harden high-speed steel?
- (d) How do we anneal high-speed steel?

VII.(a) What are the combinations of metals (alloys) used in high-speed steel?

- (b) State which of the above are used to give the steel the following qualities:
 - (1) Higher heat resistance.
 - (2) Ductility.
 - (3) Chief factor in control.
 - (4) To prevent from cracking.
- (c) (1) What are the disadvantages of using high-speed steel machine tools?
(2) What are the advantages?

VIII Compute the length of stock required for

- (a) Link 3" long, 2" wide, $\frac{3}{8}$ " stock.
- (b) Ring 3" diameter, $\frac{1}{2}$ " stock.
- (c) 1" standard hook.
- (d) Width of bolthead for $1\frac{1}{2}$ " bolt.



CARPENTRY CONSTRUCTION MODEL
DUNWOODY INSTITUTE, MINNEAPOLIS

ROCKING DUCK

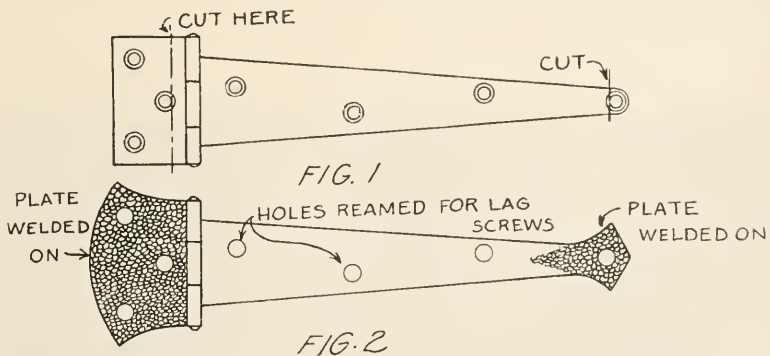
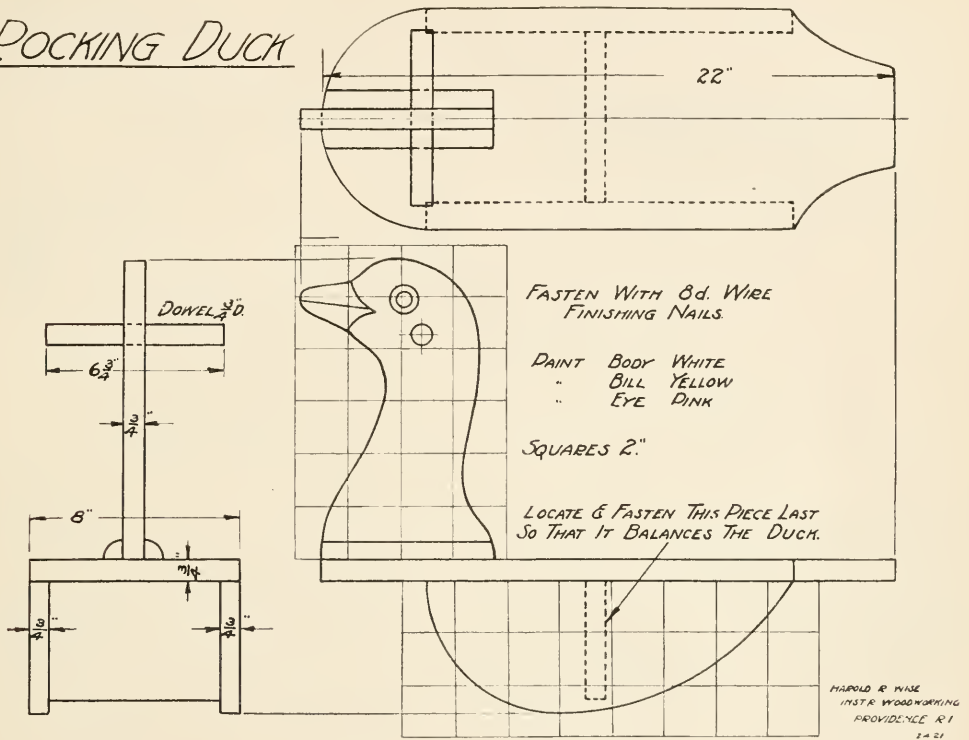

MAKING CHEAP ORNAMENTAL HINGES

MANY times it is desirable to use an ornamental hinge when a big outlay of money is not justified. The making of such hinges is a project which furnishes a ready method of producing cheap ornamental hinges.

Use a pair of T-hinges having straps about 14

inches long. Cut the tip of the strap behind the screw hole, and likewise the T-plates as shown in Fig. 1. To these cuts weld suitable iron plates which are trimmed to suitable ornamental designs, and peened to receive the finish. Bore holes to receive lag screws.

—EDWIN M. LOVE.

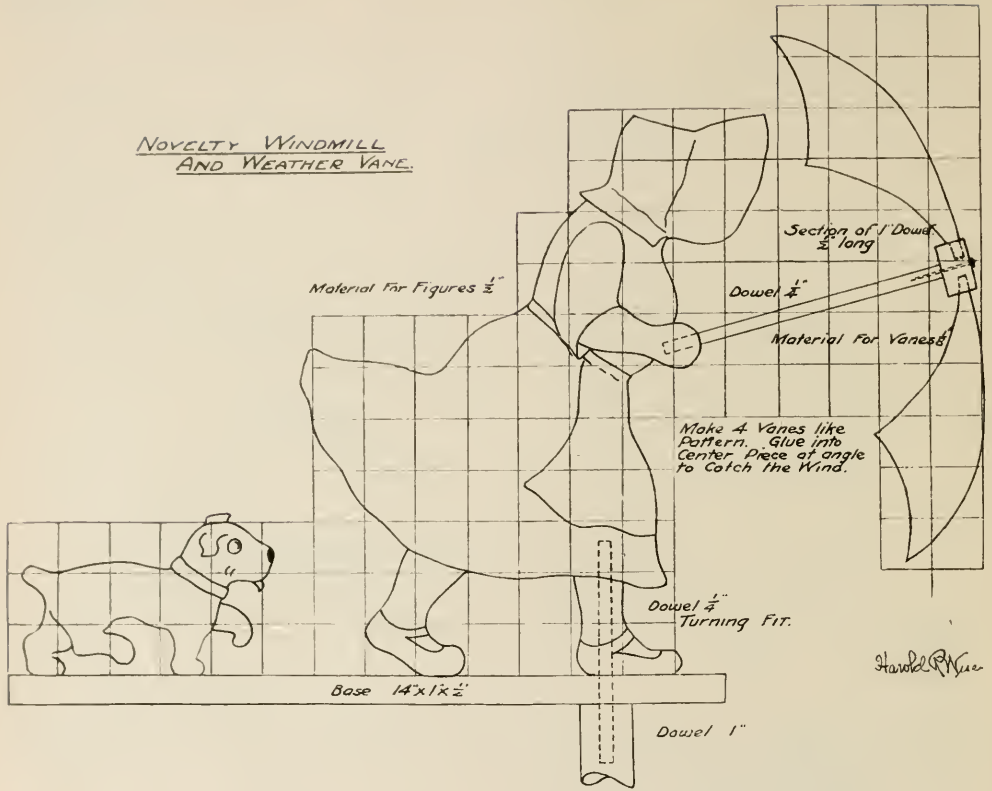

WINDMILL DRAWING CONTRIBUTED BY HAROLD R. WISE, PROVIDENCE, R. I.



PROJECTS MADE BY EIGHTH GRADE BOYS, LILINOKALANI SCHOOL, HONOLULU
ANTHONY C. PEREIRA, INSTRUCTOR.

WINDMILL

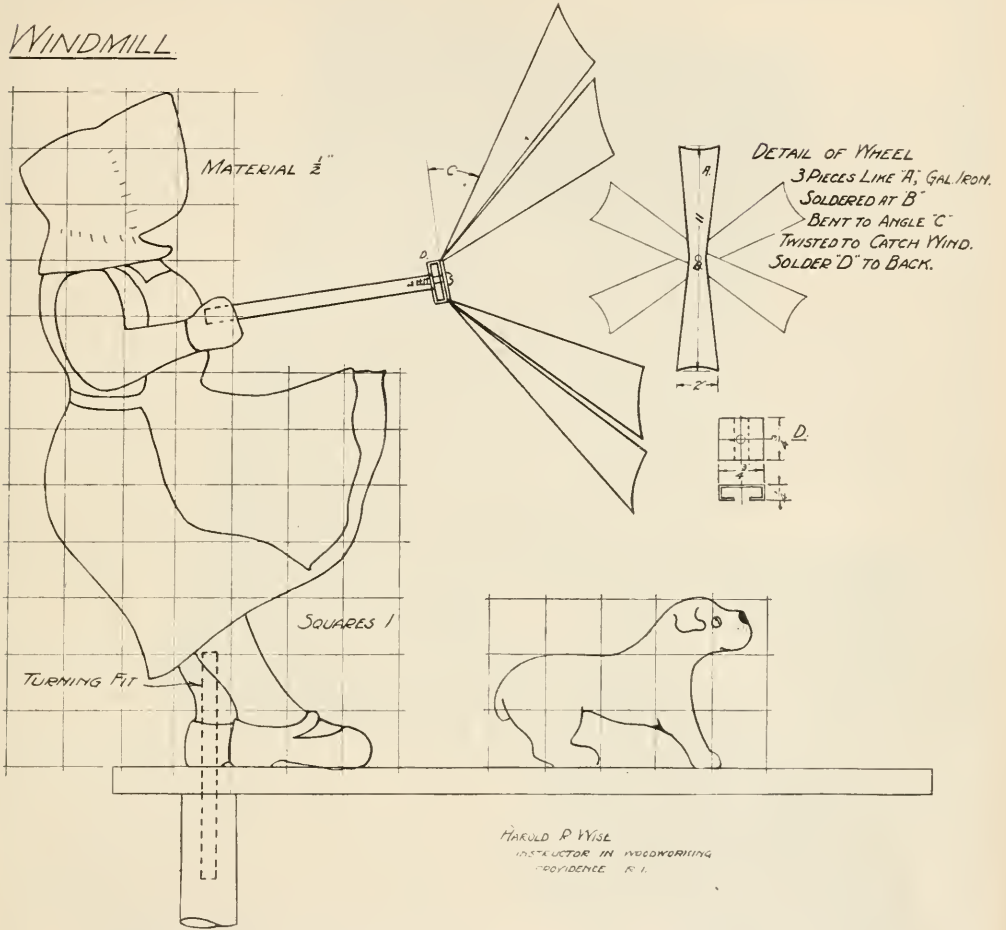

WINDMILL DRAWING CONTRIBUTED BY HAROLD R. WISE, PROVIDENCE, R. I.



LILINOKALANI SCHOOL, HONOLULU, HAWAII
J. A. WILSON, PRINCIPAL.

CURRENT PUBLICATIONS

Fundamentals of Practical Mathematics. By George Wentworth, David Eugene Smith and Herbert Druery Harper. Ginn & Company, Boston, 1922. Size $5\frac{3}{4} \times 7\frac{1}{2}$ in.; 202 pages.

This book has several noteworthy features. In the first place, it is prepared by men, two of whom have long stood at the head of the group of writers on mathematics.

In the second place, these men have been studying the changing conditions in mathematics teaching which has come about, owing to the development of vocational education and the introduction of industrial arts into general education. They have come to the conclusion that "the most usable type of book should be based upon the assumption that the student has had a good course in elementary arithmetic, including the simple graph, but is in need of a brief review and that such a book should contain those basic principles which the student must know, whatever special vocation he is to follow.

In the third place, the book includes about thirty-five full-page plates, most of them blueprints, giving practical data such as is common in the industries and giving it in almost the same form as it appears in the industries.

Whether the book proves to be the best book for classes that have been known as "shop mathematics" or not, it seems to mark another stage in the development of mathematical teaching in public schools.

Construction of Radio Phone and Telegraph Receivers for Beginners. By M. B. Sleeper. Norman W. Henley Publishing Co., New York, 1922. Size $7\frac{3}{4} \times 5\frac{1}{8}$ in.; 142 pages; paper cover; price, 75 cents.

Radio apparatus is developing so rapidly at the present time that no book can contain all the latest developments, but this little book gives a great deal of text information and some working drawings and photographic illustrations that will be of real help to the amateur who wishes to construct some of his own radio apparatus. The eighteen chapters in the book cover the various phases of the subject.

American Private Schools. Published by Porter Sargent, 14 Beacon Street, Boston. Size, $7\frac{1}{4} \times 5$ in.; 896 pages; price \$4.00.

This is the seventh edition of an annual critical directory of private schools and summer camps. In the fore part of the book are the following interesting chapters: "Review of the Educational Year," "The Situation in the Colleges," "Education in Europe," "Recent Educational Literature."

RECEIVED

Report of the Annual Convention of the National Vocational Guidance Association. Bulletin No. 3, May 1922. Anne S. Davis, president, 460 So. State St., Chicago.

The David Ranken Jr. School of Mechanical Trades. St. Louis. Thirteenth annual catalog, 1922-23.

Higher Standards for Teachers of Industrial Subjects. Organization of Industrial Material in Individual Units. The Contribution of Correspondence-Instruction Methods to Industrial Education. Helping the Shop Teacher Through Supervision. By William T. Bowden. Industrial Education Circulars No. 7, 8, 9, and 10, respectively. Issued by the U. S. Bureau of Education, Washington, D. C.

Tests in Manual Subjects. By D. J. Mac Donald, Professor of Vocational Education, University of Cincinnati.

Part-Time and Continuation School News Notes. A periodical issue by the University of California, Berkeley, California.

Art and Industrial Arts. A handbook for elementary teachers, prepared by Leon Loyal Winslow. Published by the University of the State of New York Press, Albany. Provides some unusual material in connection with the general topic of industrial arts.

Standard Apprenticeship Courses for Printers. Outline of Lessons. Compiled and published by United Typothetae of America, Chicago.

The Case of the Low I. Q. By John L. Stenquist. Reprinted from *Journal of Educational Research*. Published by C. H. Stoelting Company, Chicago.

Report of Conference on Improving Foremanship. Issued by The Wheeler, Osgood Company, Tacoma, Washington. This conference was held under the auspices of the State Board for Vocational Education, and The Wheeler, Osgood Company, and is one of a series of conferences being held for the improvement of foremanship.

General Construction Safety Orders.

Trench Construction Safety Orders.

Air Pressure Tank Safety Orders.

Engine Safety Orders.

General Safety Orders.

Woodworking Safety Orders.

Workmen's Compensation, Insurance and Safety Laws. A series of pamphlets issued by the Industrial Accident Commission of the State of California, Los Angeles.

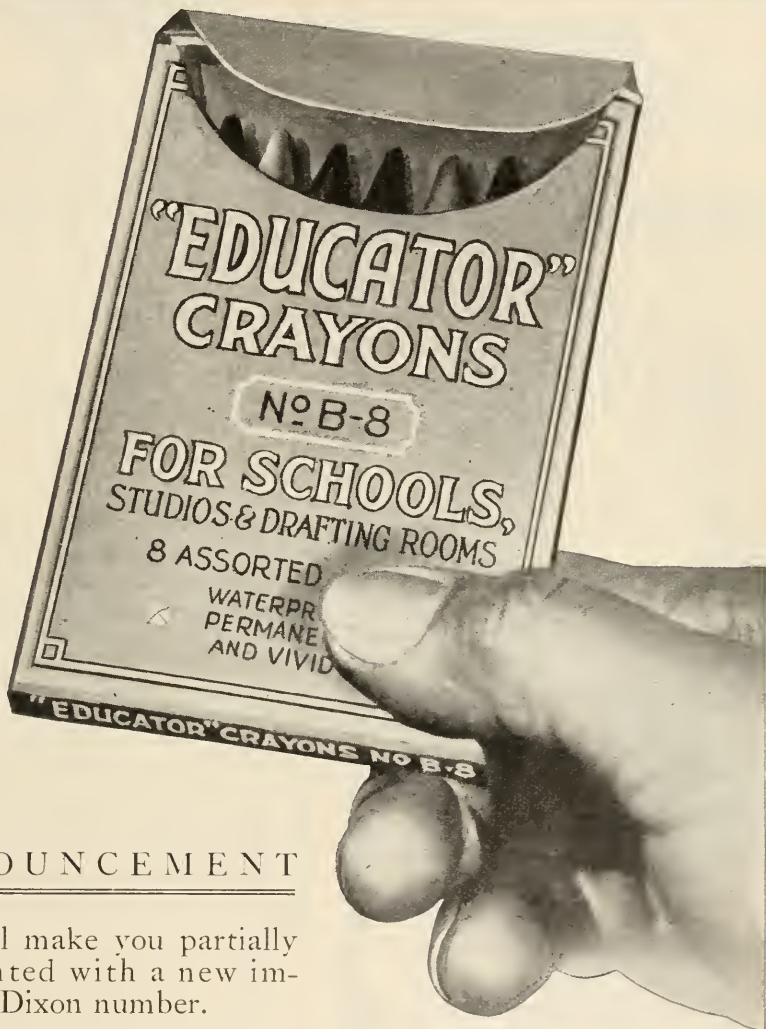

ANNOUNCEMENT

This will make you partially acquainted with a new important Dixon number.

It is a wax crayon you will want to become fully acquainted with.

Its name is "Educator".

The eight-color assortment is now ready.

Shall we send you samples?

JOSEPH DIXON CRUCIBLE CO.

Pencil Dept. 19-J

JERSEY CITY, NEW JERSEY

TOOLS HARDWARE AND SUPPLIES

Is the title of our New
317 Page Catalog and
which is of interest to
every Manual and Vocational
Training Director.

When asking for Copy please
specify Catalog No. 239

**Hammacher
Schlemmer & Co.**

New York Since 1848

4th Ave. and 13th St.



FIELD NOTES—(Continued)

of Minnesota, April 11-15. The first was held at the Minnesota Union with Professor Arthur F. Payne as chairman. James A. Starkweather, assistant superintendent of schools, and director of vocational education, Duluth, spoke first. He took a long look into the future to see where vocational education would be, and what it would be. George M. Brace, supervisor of manual training, St. Paul, spoke of the new methods of testing for vocational ability.

The second meeting was held the following evening, April 12, at Dunwoody Institute, with James A. Starkweather in charge. Arthur F. Benson, principal of the Jordan Junior-High School, Minneapolis, was the first speaker. He spoke of place, value, and function of the practical arts in the junior-high school. A try-out or exploratory course in typewriting was strongly advocated as an additional course in the practical arts. He would place it there both as a highly interesting manipulative subject and as an exploratory course. He considers it highly successful in the latter case if it should do no more than eliminate that subject from the thoughts of many who might otherwise embark on much longer courses. The value of music was placed very high. In English and history the student's brain should not be a storehouse of interesting but valueless information, but the subject should be presented so that the child would be responsive and enjoy the subject to the full while he was pursuing it, postponing highly technical and minute details to later years.

COMMITTEE ON INDUSTRIAL TRAINING REPORTS

John F. Friese, director of manual arts, St. Cloud, speaking for the Committee on syllabi in General Industrial Training, appointed by the state department, gave a preliminary report of the work done by this committee. Complete outlines of courses of study for the various kinds of shopwork and drawing for the different grades were suggested. Methods, equipments, schedules, bibliographies and sundry helps will be included in the final report. The syllabi were prepared for what was designated as a "typical Minnesota high school." This is a school in a city of not more than 6,000 population, with a one or two-teacher manual arts department, and usually not more than two rooms, containing a minimum of 1,000 square feet. The large composite general shop was strongly advocated.

R. T. Craigo, principal of Dunwoody day school, told of the methods followed in that trade school

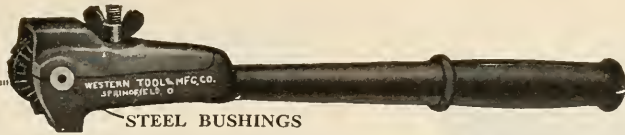

The "Champion" No. 1 Emery Wheel Dresser

Will Outlast a Dozen Cheap Dresser Handles

Handle is made of malleable iron, will not break. The spindle on which the cutters run is of steel. The bushings in which the spindle runs, are also of steel. Easily replaced.

"Tools of Quality" Ask for our Full Catalog

WESTERN TOOL AND MANUFACTURING CO. Springfield, Ohio

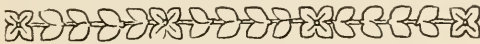

FIELD NOTES—(Continued)

in teaching related subjects. The teacher, and the particular phase of related matter, determines whether that material would be taught in the shop with equipment around, or in a classroom. Both methods are followed successfully. Student helpers or monitors are frequently used to help the instructor with the related work.

—JOHN F. FRIESE.

PRINTING TEACHERS IN SESSION

"THE education department of the United Typothetae of America is in sympathy with the movement that printing instruction to apprentices be given in the public schools, provided, that the aim of the course is clearly defined, that a practical printer is employed as the instructor, and that this instructor is a good teacher and capable of imparting his knowledge to boys."

This was the keynote of Layton S. Hawkins, formerly head of the Federal Board for Vocational Education, and now director of the education department of the United Typothetae of America, in his address before the New York—New Jersey Chapter of the National Association of Printing

PARKS Jewel

22-in. Band Saw Machine

Particularly adapted to Manual Training School Requirements

Not an expensive machine—but a thoroughly practical band saw. Best construction throughout. Two-inch angle-steel frame, rigidly bolted, practically vibrationless. No repairs—nothing to get out of order.

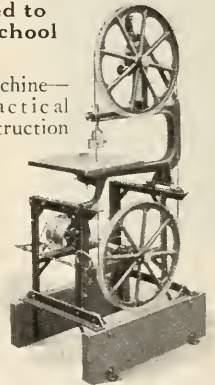

Price \$70.00

Send for Complete Catalog of Parks Machines

The Parks Ball Bearing Machine Co.

1536-46 Knowlton St. Cincinnati, Ohio

Canadian Factory:
200 Notre Dame East, Montreal, Canada

PARKS

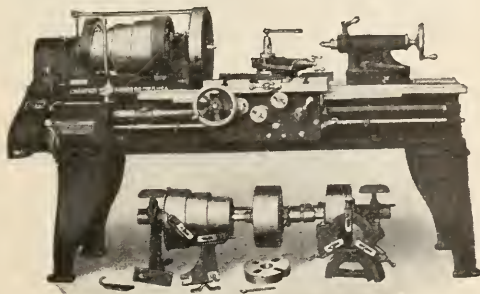

Champion Lathes

A quality engine lathe, accurate, convenient to operate and at a very attractive price to manual training and vocational schools.

Not the Cheapest, But One of the Best.

Made in four sizes: 13", 15", 17" and 19"

Champion Tool Works

Winton Place

Cincinnati, Ohio

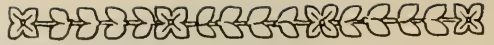

FIELD NOTES—(Continued)

Teachers at their semi-annual meeting in New York City, Saturday, April 29.

Following his statement that the aim of the course of instruction shall be clearly defined, Mr. Hawkins said that at the very beginning the school should decide what type of instruction is to be given. "Will it be manual training, prevocational or vocational?—and after that is decided upon, plan your course accordingly." He said he sometimes pictures printing instruction as going through a funnel-like process, containing a number of sieves. The top one holding the manual training school, under that the prevocational, under that the vocational, and finally thru the spout or nozzle, an entry to the industry. And from the present condition of the industry, he was of the opinion that in the past the wrong kind of sieve has been used. However, he expressed a belief that things are turning to the better.

Production in the school print shop is another difficulty that presented itself during his study of the situation. While he was not entirely opposed to having some practical printing jobs done in the school shop, he said, in too many cases the school shop was used by some boards of education as a commercial print shop, and unless a particular printing job fits into the instructor's course, it should not be done in the school print shop.

On the matter of placing boys in the industry, he said the employing printers in a number of cities are going directly to the vocational schools for their apprentices, and in many cases the boys are given credit for their training received in the school. Incidentally, he said he is an advocate of the five-year apprenticeship period. In concluding, he expressed hope that the situation will soon be in a better state of affairs than ever before.

The short business meeting which followed the address included the election of officers and appointment of committees. The officers elected for the ensuing year are: George T. Middleton of Hackensack, N. J., president; Arnold Levitas of New York City, vice-president; David Daniels of Newark, N. J., secretary-treasurer.

—DAVID DANIELS,

West Side School, Newark, N. J.



**Vol. II
Is Ready**

**WRIGHT'S
AUTO-
MOTIVE
REPAIR**

For the Electrical Service student; the service station man specializing in electrical work, and the owner who does his own repairing. Full details of 56 jobs given, with necessary theory.

+17 pages. 6x9. 405 figures. \$3.00

**Wright's
Automotive Repair**

Vol. I, for general repairmen, is now in use at 72 schools—\$3.50.

FREE EXAMINATION COUPON

John Wiley & Sons, Inc.
432 Fourth Avenue, New York City.

You may send me the following on 10 days' approval:
Wright's Automotive Repair—Vol. I—Vol. II

I agree to pay for the book or return it within 10 days' of receipt.

Name

Address

If teacher, state school

If not teacher, give reference

M.T.M. 6-22

TOOLS

For Manual Training Shops.
Send your inquiries to and get the especially low prices quoted by

MONTGOMERY & CO. Inc.,
105 Fulton Street New York City

L-U-M-B-E-R

We Specialize in
Manual Training Lumber

No order is too large or too small to receive
our careful attention

John S. Benedict Lumber Co.
419 N. Halsted St. CHICAGO

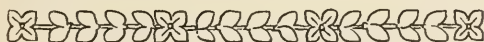

FIELD NOTES—(Continued)

FARM SHOP EXHIBIT IN GEORGIA

One of the most interesting exhibits at the South-eastern Fair was that of the vocational agriculture departments of the high schools of the state. The Fair Association gave prizes of \$250.00 to the schools, and the first place, which carried a prize of \$75.00 went to Stone Mountain school. In this exhibit was a wagon box just as good as any wagon box that ever came out of a wagon factory.

The exhibits consisted of self feeders for hogs, dry mash hoppers, trap nests, single trees, hammer handles, corn drying racks, creosoted fence posts, brooders, and other useful farm equipment.

—FOREST T. SELBY.

REQUIREMENTS FOR MANUAL TRAINING CERTIFICATES IN OKLAHOMA

A DEFINITE set of regulations governing the issuance of certificates to teachers of manual training in the state of Oklahoma have been adopted by the State Board of Education, as reported by Hugh Norris of Ada, secretary of the Industrial Education Association of Oklahoma. As a prerequisite for a life certificate after this year the

Build Your Own PHONOGRAPH

Instructive—arouses pupils' enthusiasm—provides one of the best problems in cabinet making.

Let Your Pupils Build
Choraleon Phonographs

We furnish plans, blue prints, motors, tone arms, case material—in fact, everything required. Full instructions. Choraleon's have fine tone. Play any record. Ask for particulars.



CHORALEON PHONOGRAPH CO.
622-7th St., Elkhart, Ind.

The American Crayon Company

Established 1835

SANDUSKY, OHIO

NEW YORK

Blackboard Chalks	Art Materials
Waltham	Prang Water Colors
Hygieia Dustless	Prang Pastello
Dovercliff Dustless	Prang Crayograph
Sterling	Prang Crayonex
American	Prang
Colored	Paper Pencils
Chalk	Prang Reliefo

Kroma Paste

We shall be glad to send
you booklets describing
these materials more fully

The Boy Agriculturist, published by the St. Charles [Ill.] School for Boys, says:

"As an evidence that the printing trade is one of the best bets at this school we sent out several boys last month and all are at good jobs, and making from \$16.00 to \$35.00 per week."

The school printing plant gives valuable practical, educational knowledge that fits its students for positions inside printing industries as well as for other activities in life. A knowledge of the Printing Art lends dignity to the consideration of the problems of the world and helps to solve them.

We can equip any school with
print plants

BARNHART BROTHERS & SPINDLER

Chicago Washington Dallas Saint Louis
Kansas City Omaha Saint Paul Seattle

Pamphlets for Home Study

Wiley Publications

THE Division of University Extension, Massachusetts Department of Education, **James A. Moyer**, Director, has brought out in pamphlet form, instruction material for **home study for class and correspondence** instruction, and for the Bureau of Navigation, U. S. Navy. Short descriptions of the three sets of pamphlets already published are given below.

Practical Steam Engineering

Of practical assistance to men employed in engine and boiler rooms. Sufficient theory is given to explain common causes and effects in steam engineering.

In 20 Assignments, each bound separately—paper—\$2.50.

Practical Electricity

Including material taken from **Timbie's 'Essentials of Electricity.'** A course in the practical applications of electricity.

In 20 Assignments—7 pamphlets—\$3.00.

Marine Steam Turbines

Treats the principal features of construction, method of operation, and the proper care of marine steam turbines.

In 31 Assignments—(4 now ready—25 cents each).

WILEY FREE EXAMINATION COUPON

John Wiley & Sons, Inc.,
432 Fourth Avenue, New York City.

You may send me the following on 10 days' approval:

I agree to pay for the books or return them within 10 days of receipt.

Name

Address

If teacher, state school

If not teacher, give reference

M. T. M. 6-22

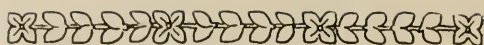

FIELD NOTES—(Continued)

manual training teachers must have completed 64 semester hours of college work, half of which must be shopwork and drawing. The regulations prescribe specifically the type of shopwork which the teacher must have and how many hours of each kind, and the same is true of the types of drawing required. Schools which do not insist on these requirements when hiring teachers for industrial work will lose their affiliation with the state. Temporary certificates may be granted, provided the teacher takes advantage of summer schools to obtain additional credits.

The Industrial Education Association of Oklahoma has been actively engaged for some time in promoting the setting up of standards for teachers in this field claiming that such standards will greatly increase the general effectiveness of the industrial program in the state.

TWENTY-FIFTH YEAR OF BRADLEY INSTITUTE

AS PART of a celebration in recognition of the twenty-fifth anniversary of the founding of the Bradley Polytechnic Institute, Peoria, Illinois, there was held, on April 28 and 29, an educational conference to which were invited the high-school principals and superintendents from the area surrounding Peoria.

At a banquet which was held on the evening of April 28, and which was presided over by Dr. Theodore Burgess, president of the Institute, speeches were made by Professor E. H. Cameron, department of education, University of Illinois; Dr. Claude A. Phillips, Dean of Faculty, State Teachers' College, Warrensburg, Missouri; and E. C. Fisher, superintendent of schools, Rock Island, Illinois.

Dr. Anna Y. Reed, formerly head of the Junior Section of the United States Employment Service, and now connected with the University of Chicago, was one of the speakers at the conference. Her topic was "Educational Responsibility for Problems Involved in Junior Employment." At a noon meeting, Mrs. Reed met with a group of local business men who are interested in the vocational guidance movement, at which time she spoke on the principle of interviewing young people with regard to their vocation. She pointed out strongly the necessity of winning the confidence of the young person before any effective advice can be given, and related some instances from her varied experience to show how a business man or woman can be of great help to the young people provided their confidence is first obtained.

THE
SYRACUSE
NAIL SETS

Are the Standard of the World

THEY are the best that high grade material and experience can produce. Made of Twist Drill Steel, with both ends tempered. The bodies are *knurled* and the points *cupped*. Finely blued the full length.



THE NOROL

has flat sides and cannot roll away

*Specify "Syracuse" Nail Sets
if you want the best.*

Write today for our descriptive booklet.

SYRACUSE TWIST DRILL CO.

SYRACUSE, NEW YORK



Any "Oliver"
Vise is a
Bargain

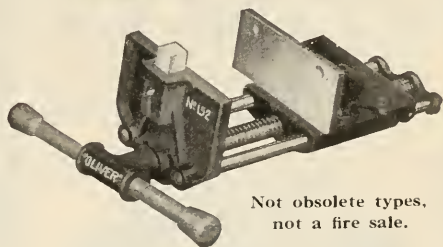

Not obsolete types,
not a fire sale.

They are built in large quantities and by jigs and fixtures the production costs are such as to permit marketing at bargain prices.

"Oliver" Woodworking Vises are —

1. Well designed
2. Strong
3. Well built
4. Parts interchangeable
5. Continuous screw or rapid acting.

Oliver Machinery Company
Grand Rapids, Mich.

SAW TABLES

For Manual Training

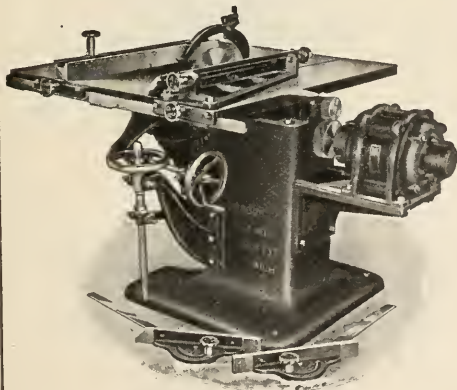

This cut shows our motor driven spiral gear saw table. No countshaft, no belts. Tilting or stationary tops. Write for circular and prices on our entire line. *Address*

ALEXANDER DODDS CO.

451-453 Monroe Ave., N. W.
GRAND RAPIDS, MICHIGAN, U. S. A.

In Gt. Britain: OLIVER MACHINERY CO., Manchester, Eng.

**Clear Redwood
at Attractive Prices**

THE desirability of clear Redwood for making bird houses, coat racks, book cases, tool boxes, trays, cabinets, chests, etc., is thoroughly appreciated by instructors in manual training and industrial arts.

Our extensive re-manufacturing operations provide an immense stock of thoroughly seasoned and dried clear Redwood 3 to 9 feet long, 1", 1 1/4", 1 1/2" and 2" thick, widths 3" to 6", which can be had at attractive prices.

*Send us your specifications and we
shall be glad to send you free Red-
wood samples and quotations.*

THE PACIFIC LUMBER CO. of Illinois
2090 McCormick Bldg. • 846 No. 40 Rector St. Bldg.
Chicago New York City

The Pacific Lumber Co.
Redwood

*The Largest Manufacturers and Distributors of
California Redwood*

STANLEY Tool Chests

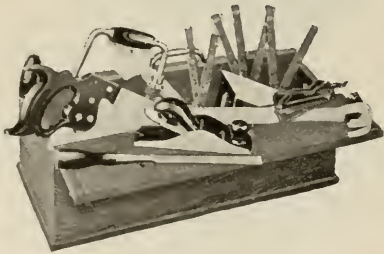

No. 888 "D"

INSTRUCTORS: Tell your boys who graduate this month, they can purchase Stanley Tools in Chests—the same tools with which they have been working during their school year.

Assortment "D" (shown above) contains a complete set of wood-working tools that will give good service for many years to come. They are tools to make things with, of a quality and accuracy that manual training graduates and skilled artisans will take real pride in owning.

Ask your hardware dealer to show you Stanley Tool Chest No. 888, Assortment "D"



The Stanley Rule & Level Plant
THE STANLEY WORKS
NEW BRITAIN, CONN.

New York Chicago San Francisco
Los Angeles Seattle

*Manufacturers of Wrought Hardware
and Carpenters' Tools*

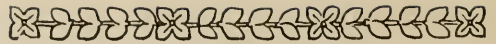

FIELD NOTES—(Continued)

SUMMER CONFERENCE AT DUNWOODY INSTITUTE

THE Federal Board for Vocational Education will carry on a series of summer conferences on foremanship training and foreman-conference training, from July 17 to August 12, and a special conference on home economics training from June 12 to July 7. These Federal-Board conferences will be held at the Dunwoody Institute, but are entirely under the control of the Federal Board for Vocational Education, and admission to them must be secured thru application to the State Board for Vocational Education in each state.

A large number of other conferences are to be offered by the institute. For these application should be made directly to the school.

TRADE NOTES

COMMERCIAL exhibits at the Western Arts Association meeting held in Cincinnati, May 2-5, constituted an interesting and important part of the convention. The opportunity to examine such a wide range of school-shop equipment and supplies greatly serves the interests of teachers and supervisors.

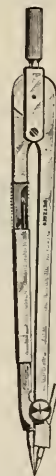

*For preliminary
work in drawing*

these unique compasses have met with great favor for school use because of their general utility.

Student "Solid" Compasses

are nickel silver, 5 inches long, durable and well constructed. An extra lead is contained in a recess, protected by a sleeve, on one of the legs. Singly on card.

1292. Compasses, as above, Dz. cds., \$3.00
1292B. Same, but with lead box, " " 3.50
1292L. Lead box, with extra leads, Dz., .50

EUGENE DIETZGEN CO.

Right goods at right prices
continuously since Year 1885

Branches:
Chicago New York
New Orleans Pittsburgh
San Francisco



Sales Offices:
Philadelphia Washington
Factory:
Chicago, Illinois

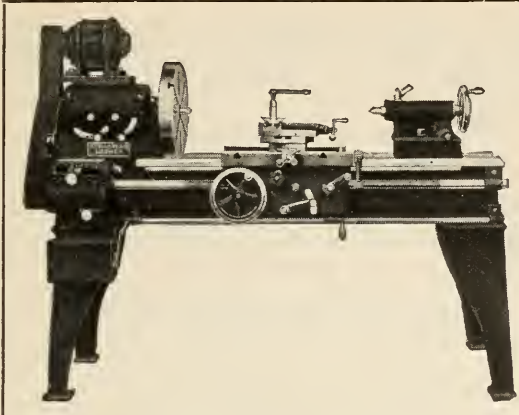

SEBASTIAN LATHES

Teach your students on a standard engine lathe backed up by 35 years of exclusive lathe building experience. 13-15-18" swing. All types.

Send for catalogs.

The Sebastian Lathe Co.
100 Culvert St.
Cincinnati, Ohio, U. S. A.

SIMPLIFY GRINDING

With Mummert-Dixon Oilstone Grinders. Five wheels for almost every class of grinding. They accomplish the work quickly and accurately. With this machine your students can experience the pleasure of sharp tools.

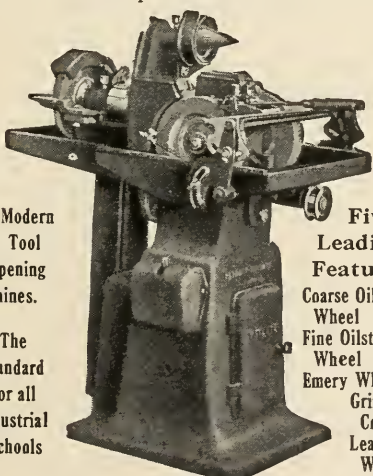

The Modern
Edge Tool
Sharpening
Machines.

The
Standard
for all
Industrial
Schools

- Five
Leading
Features**
- Coarse Oilstone Wheel
 - Fine Oilstone Wheel
 - Emery Wheel
 - Grinder Cone
 - Leather Wheel

Furnished for motor drive or with counter-shaft
Send for full descriptive bulletin
MUMMERT-DIXON CO., Hanover, Pa.



FOR WIDE RANGE The Tannewitz Type "F"

Variety Saw Bench with Tilting Table

Long Life And Accuracy are guaranteed by the extra heavy, hollow cast base which protects the working parts.

Motor is Wound Directly On Arbor eliminating belts, pulleys, etc., and saves floor space.

A Very Wide Range. Cuts off 18" and rips 24". A thoroughly efficient set of gauges is provided.

Heavy Tilting Table. Hung on machined dovetailed hinges adjustable for wear. Tilts and locks almost instantly. Elevates and locks for accurate grooving.

Very Safe. Door on dust chute covers saw but permits quick access. Steel Splitter Guard, Adjustable Cage Guard and Safety Switch.

*Why buy more than one machine?
Write now for special literature.*

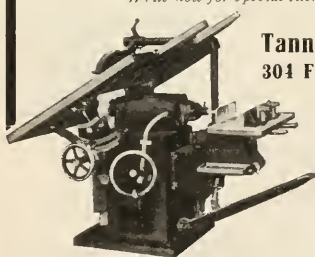

The
Tannewitz Works
304 Front Ave. N.W.

Grand Rapids, Michigan

The table area of Type "F" Variety Saw Bench is exceedingly large.

Frank Paxton Lumber Co.

Kansas City, Kansas

We carry the most complete stock of domestic and foreign woods suitable for Manual Training

"JORGENSEN" HAND SCREWS

Withstand the abuse of inexperienced hands.

Steel Spindles
Steel Nuts
Hard Maple Jaws

Adjustable Clamp Co.

216 N. Jefferson St., Chicago



SIMONDS SAWS

For better and smoother work Manual Training and Vocational Schools use Simonds Saws. They are the best, but they cost no more than some inferior saws.

Simonds
Manufacturing Co.

"The Saw Makers"
Fitchburg, Mass. Chicago, Ill.
5 Factories 12 Branches

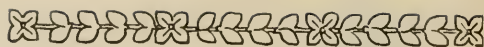

TRADE NOTES—(Continued)

PRINTING EQUIPMENT EXHIBITS

The rapidly growing interest in printing as a school subject makes printing equipment exhibits an attractive center. Frank K. Phillips, of the American Type Founders Company, who has done so much to popularize this subject, had an exhibit which included a Chandler-Price Press, Pearl Press, American School Case Rack, Poco Proof Press, Official Hand Lever Press, and a Boston Stapler. The booth was decorated with a handsome copper colored bust of Benjamin Franklin. At the close of the convention this bust was turned over to E. E. Cristy, supervisor of industrial arts in Cincinnati, who in turn will give it as a prize in a local printing contest.

ANOTHER interesting printing exhibit was that of Barnhart Brothers & Spindler, Chicago. Their exhibit consisted of a complete school equipment including a press, latest improved type-cabinets, imposing stone, and a stereotype equipment arranged especially for school purposes. They had on exhibit also one of their Superior Point-System Saws. In addition there were many beautiful examples of well-composed pieces of printing.

EXHIBITS OF WOODWORKING MACHINERY AND TOOLS

Since woodworking constitutes such a large part of school shopwork, it is to be expected that exhibits of equipment for this work will be centers of interest. The American Woodworking Machinery Company, Rochester, had four machines on exhibit, including mortiser, lathe, universal saw, and jointer. This firm is distributing a unique piece of printing entitled "On the Manufacture of a Teacher's Flat Top Desk." It describes and illustrates every operation involved in the manufacture of this necessary piece of school furniture. Teachers who have not received a copy of this booklet, should send for it at once.

Give Your Pupils SHOP-WORK THAT PAYS

Let the Boys Build Phonographs

Imagine the pride and joy of your pupils in building *their own phonographs* (equal in quality to high-priced standard machines) either to sell or take home as a source of lasting pleasure. Think how this project will add to your popularity as an instructor. Building phonographs is easy, by our methods, yet it demands precision and delicacy of workmanship, the very points always emphasized in shop practice. *Send 10c for fine illustrated catalog*

and full information about our co-operative plan for manual training teachers. We plan the work for you. We supply blueprints, tone-arms, motors, case material and all accessories at lowest prices. Detailed instructions furnished. Materials best obtainable, fully guaranteed. Our machines play any make record. Write us TODAY.

HOOSIER MANUFACTURING & SUPPLY CO.
PHONOGRAPH SUPPLY DEPT.

315 Baldwin Block, Dept. A.

Indianapolis, Ind.

MAYDOLE HAMMERS

THE WORLD'S STANDARD

Highest Quality Steel Handled Hammers
Guaranteed First-Class in Every Respect

*Booklet of Useful Information
for each student on request.*

The David Maydole Hammer Co.

Norwich. N. Y., U. S. A.



Hard-To-Get Materials

This is the Line you have
been looking for

Unusual Cabinet Hardware
Chest Trimmings
Upholstery Supplies
Cushions
Mirrors

Catalog to Instructors

Thurston Manual Training Supply Co.

Jobbers and Manufacturers
ANOKA, MINNESOTA

Crescent Wood Working Machinery

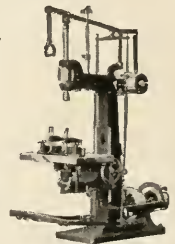

is substantially built and if your students are given an opportunity to become familiar with the quality of this splendid line of wood working machinery, the knowledge will be valuable to them in later years when they are placed in positions of responsibility in Industrial Plants.

Send today for catalog telling about our splendid line of band saws, saw tables, shapers, jointers, variety wood workers, planers, cut off saws, disk grinder, post borer, hollow chisel mortiser, universal wood workers.

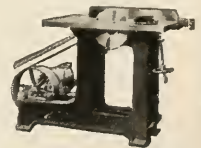
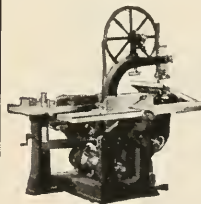

**The Crescent
Machine Co.**

46 Cherry St. Leetonia, O.



NEW **LUFKIN**

HIGH GRADE YET POPULAR PRICED
ACCURATE—DURABLE—WELL DESIGNED
No. 65L—WITH LEVEL No. 65—WITHOUT LEVEL

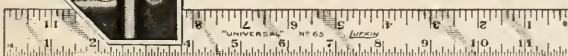

Distinct marking; movable yet secure head. Serves also as marking, height and depth gauge, level and plumb, and separate rule. *If Unobtainable at Dealers Write Us Direct.*

Made in 9-inch and
12-inch lengths

Send for Catalogue

THE LUFKIN RULE CO.

SAGINAW, MICH.
New York

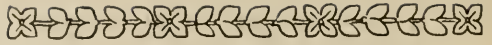

Industrial Arts

In Our

Elementary Schools

By A. H. EDGERTON
Assistant Professor Indiana University

A DEPENDABLE presentation of industrial arts teaching. It is based upon a survey of 141 school systems and includes signed statements from supervisors and teachers giving the results of their experiences. It presents a fund of information as to, What to teach in grades I to VI; How to teach it; How to correlate with other subjects in the elementary school curriculum.

It deals with a wide variety of educational material, including:

Clothing and textiles — shelter — wood — paper making — food — metals, iron and steel — brick making — home making — pottery and chinaware — individual projects — class projects — illustrative projects, etc.

Here is the answer to the often asked questions, Are the older lines of work adequate to meet new conditions, and new educational ideals? Are the proposed changes practical?

**A STOREHOUSE OF FACTS
AND SUGGESTIONS FOR
TEACHERS IN GRADES
I to VI.**

*Bound in heavy paper.
Postpaid, 50 cents.*

The Manual Arts Press
Peoria, Illinois

OLIVER MACHINERY COMPANY, Grand Rapids had a representative exhibit of woodworking machinery for school shops, which included their No. 766 jointer, No. 80-D variety saw bench, No. 91-D mortiser, one 10" x 4'-3" all-steel, geared-head, screw-cutting engine lathe, one 12" x 5'-3", cone-head, screw-cutting, engine lathe, standard counter-shaft drive. Both lathes were equipped with Oliver selective change gear. All machines displayed were of the latest improved types, showing exclusively the direct connected motor drive.

VISITORS were much interested in the extra smooth surfacing done by the No. 500 Variety Saw, shown in the exhibit of Fay & Egan Co., Cincinnati. This firm displayed also their No. 400-D lathe and No. 502 bench jointer.

THE PARKS BALL BEARING MACHINE COMPANY, Cincinnati, had several of their woodworking machines on exhibit, including the "Jewel" 22-inch band saw, "Progress" 16-inch turning lathe and new rapid hollow-chisel mortiser. This firm makes quite a line of moderate priced woodworking machinery, all of which is fully described in Catalog C, a copy of which will be forwarded upon request.

ONE OF THE SPECIAL features of the exhibit of The Stanley Works, New Britain, Connecticut, was their No. 5¼ plane. This plane is unique, in that it can be used in both the grammar grades and high school. It is the outgrowth of discussions which E. A. Cherry has conducted with prominent shop teachers all over the country, each contributing suggestions for securing a perfectly balanced plane to be placed in the hands of students. Anyone who is not acquainted with this plane, may write The Stanley Works, New Britain, Connecticut, and receive literature describing it fully.

THE EXHIBIT of Henry Disston & Sons, Philadelphia, consisted of a full line of saws, tools, and files for school shops. A very helpful booklet entitled "The Disston Saw, Tool, and File Book" was distributed to visitors. A copy of this should be in the library of every school-woodworking shop; in fact, every high-school student in wood-working would no doubt be glad to have a copy, as it contains so much valuable information. Furthermore, with a copy of this book in the hands of students the instructor could hold them responsible for better care of their tools.

IN THE EXHIBIT of Simonds Manufacturing Company, Fitchburg, Massachusetts, prominence was given to their large hack-saw charts, a copy of which will be sent to directors of machine shops. Along with other literature, an interesting booklet

A. R. VINNEDGE & CO.

SPECIALISTS IN

MANUAL TRAINING LUMBER

Write for our prices

2060 Clybourne Avenue
CHICAGO

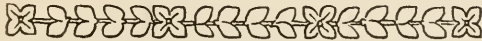

TRADE NOTES—(Continued)

describing the manufacture of a circular saw was distributed.

S. C. JOHNSON & SON, Racine, Wisconsin, were acquainting the wood-finishing teachers with their varnishes, enamels, and undercoats. As manufacturers of dyes and fillers, this firm has long been known in the school field; their varnishes are considered excellent for rubbing and polishing, and readily gives students training in the technique of this form of wood finishing. To those requesting it, they will be glad to send a beautiful poster displaying their various finishes.

DRAWING ROOM AND ELEMENTARY HANDWORK SUPPLIES

In addition to the foregoing, the following drawing room and elementary handwork supply firms were well represented with attractive exhibits: Frederick Post Co., Chicago; American Crayon Co., Sandusky, Ohio; U. S. Blue Print Paper Co., Chicago; Joseph Dixon Crucible Co., Jersey City; Milton Bradley Co., Philadelphia; and Thomas Charles Co., Chicago.

CUSHIONS

TENTS

AND

CAMPING EQUIPMENT

for your
Vacation Trip

Illinois Valley Awning and Tent Co.

102 S. Washington St.

Peoria, Ill.

LEWIS TILTING CUPOLA FURNACE

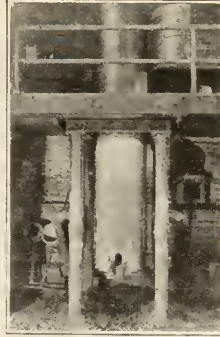

Specially
Designed
For
Technical
Schools and
College
Foundries

A thoroughly practical Cupola for the melting of cast-iron, giving the same results and phenomena as a large Cupola.

THE BABY BUNTING OF THE FOUNDRY WORLD

Economical in the use of fuel and time—can be operated by the average student without great difficulty.

Cupola can be daubed, bottom rammed in, fire started and heat taken off, and bottom dropped all inside of a two-hour period.

Nothing better for school foundries. Send for descriptive circular and prices to

GEORGE A. ROSS

Lewis Institute Bldg., 1951 W. Madison Street
Chicago, Illinois

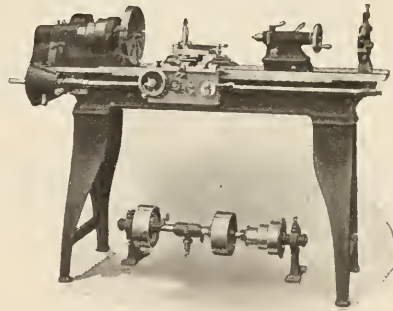

“Oliver” Engine Lathes

10-12-16-18-26-30-inch

“Oliver” Engine Lathes will appeal to you because they are well designed and built of best materials.

Accuracy and workmanship guaranteed.

“Oliver” Lathes are simple yet built with various drives. Cone or Geared Head. Furnished with full tool room attachments if desired.

Oliver Machinery Co.

Grand Rapids, Mich., U. S. A.



CLASSIFIED ADVERTISEMENTS



Do you want to sell or want to buy some school shop supplies? Do you want to employ a teacher? Do you want a new position? Advertise your wants in these classified columns. Rate 20c a line, minimum \$1.00.

BASKETRY

BASKETRY MATERIALS. Reeds, raffia, wooden bases, chair cane, Indian ash, splints, cane webbing, wooden beads, braided straw, rush, willow, pine needles, books, tools, dyes. Catalogue and Directions, 15 cents. Louis Stoughton Drake, Inc., 34 Everett St., Allston, Station 34, Boston, Mass.

REED FOUNDATIONS AND SUPPLIES. Veneered tray bottoms, clear pine bottoms, lamp standards and fixtures, galvanized iron containers, finishing materials, etc. Send for catalogue. The Kessel and Nyhus Co., 910 Westminster St., St. Paul, Minn.

BASKETRY—Pine Needles, brown and green, tied bunches, 30 cents pound, (postage extra); 35 cents pound, delayed payments. Tiny Cones 15 cents dozen. Florence Williamson, Culleopa, Tennessee.

ELECTRICAL PROJECTS

BUILD "PEPCO" ELECTRIC TOASTERS—A useful and attractive project. Buy the parts from the Practical Electrical Projects Co., Highland Park, Illinois.

BLUE PRINTS

FREE CATALOG AND SAMPLE—Blue Prints of Agricultural, Furniture Making, Mechanical Drawing, Wood Turning, Forge Work, Pattern Making and Whittling Problems. Make your work more practical. Work from blue prints. Schenke Blue Print Co., 1034 Carney Blvd., Marinette, Wis.

GRANDFATHER'S CLOCK—Blue prints, finishing material and instructions. Also works, dial, weights and pendulum can be purchased from us at surprisingly low prices. Send for particulars of our attractive offer. Clock Company, 1666 Ruffner St., Philadelphia, Pa.

FURNITURE HARDWARE

FURNITURE HARDWARE AND UPHOLSTERY SUPPLIES for Manual Training. Drawer pulls, costumer hooks, wood knobs, box fittings, tea wagon wheels, electric cluster posts, cedar chest locks, handles, hinges, etc., mirrors, wood dowels, Seng bed equipment, Stanley Tools. Send for Catalog, Ohio Vocational Supply Co., Wapakoneta, O.

ELEMENTARY HANDWORK

TAWIDO HAND LOOMS. Write for catalogue describing what I believe is the best 20" Table Loom on the market. Elna M. De Neergaard, Inventor and Maker of Tawido Hand Looms and Fixtures. 45 West 8th Street, New York City, New York.

EVERYTHING FOR ELEMENTARY HANDWORK—Also for basketry, weaving, bookbinding and chair caning. Mounting boards, Waldcraft dyes, crayons, burlap, scissors, punch and eye sets. Thomas Charles Co., 2249 Calumet Ave., Chicago.

MANUAL TRAINING LUMBER

YOU CAN SAVE MONEY AND TIME by buying OAK SQUARES and ASH SQUARES in Clear lumber, one to two inches thick and from 15 to 40 inches long. We also specialize in Cedar Chest lumber, Philippine and other Mahoganies. FRANK PAXTON LUMBER CO., KANSAS CITY, KANSAS.

AMERICAN WALNUT LUMBER—We carry a stock of over two million feet of Walnut Lumber, consisting of all grades and thicknesses from 1/2" to 4". Due to this large stock we are always in position to supply dry lumber for Manual Training use. Send us your inquiries. Frank Purcell Walnut Lumber Company, 12th Street & Belt Line, Kansas City, Kansas.

AROMATIC TENN. RED CEDAR BOARDS. Small shipments a specialty. Write us for prices delivered at your railroad station. Earthman Lumber Co., Murfreesboro, Tenn.

MORGAN MANUAL TRAINING MATERIALS—A perfect system of dry kiln enables us to give you lumber thoroughly dry. Carrying in stock large quantities of different woods permits us to fill your orders with the best selections. Write, sending us a list of the materials you desire. We will quote you attractive prices. Morgan Company, Oshkosh, Wisconsin.

LUMBER—Maisey & Dion, 2349 to 2423 South Loomis St., Chicago, Illinois, carry in stock a large and diversified stock of MANUAL TRAINING LUMBER. Fifteen years' experience with schools enables us to fill such orders satisfactorily.

SCHOOL SHOP SUPPLIES

ALLEN SODERING FLUX—Experimenting to see which is really the best flux is not necessary—in fact it is a waste of time. This point has been decided not only by Expert Chemists, but by the largest users of Flux, both in the United States and Europe. Our flux will solder any metal to any other metal so that it will stay. Our Alumi Soder will solder Aluminum. The U. S. Government uses it and it works. The Government won't have anything but the best. L. B. Allen Co., Inc., 4884 N. Lincoln St., Chicago, Ill.

UPHOLSTERY MATERIALS

CUSHIONS—You know your cushions will be made right when furnished by the Grand Rapids Cushion Company. Write for estimates on cushions and all kinds of upholstery supplies. Grand Rapids Cushion Company, Grand Rapids, Michigan.

CUSHIONS, APRONS, UPHOLSTERING SUPPLIES. If you make your own cushions we can supply the materials at reasonable prices. If you want complete cushions, we know how to make them, and our prices will interest you. Illinois Valley Awning & Tent Co., 102 S. Washington St., Peoria, Ill.



CLASSIFIED ADVERTISEMENTS



TOY CONSTRUCTION

MANUAL TRAINING OUTFITS AND ACCESSORIES for toy construction. Circular free. Working drawings with instructions for making twenty toys, 45 cents. Woodcraft Shop, 31 South 3rd Ave., Mount Vernon, N. Y.

POTTERY SUPPLIES

COMPLETE POTTERY SUPPLIES and equipment for Schools, Studios and Laboratories. Write for new pamphlet. Wm. W. Wilkins, Lewis Institute, Madison and Robey St., Chicago.

PRINTING SUPPLIES

EMPIRE TYPE FOUNDRY, manufacturers of metal type, wood type, printers' supplies. Delevan, N. Y.

ELECTRIC TOASTERS

"PEPCO TOASTERS are practical and attractive and can be easily built with parts furnished by the Practical Electrical Projects Co., Highland Park, Illinois. Write today for circular and price lists.

BRASS AND COPPER

BRASS AND COPPER WORK—The only complete line of supplies for teaching the fundamental principles of working metal, (shaping, construction and decoration), sheet copper, brass, silver, wire, tools, solders, stakes, hammers, etc. New price list for catalogs Nos. 10 and 12 are now being mailed to our regular mailing list. Write us if you do not receive yours. Order for next fall's supplies should be placed early this year as our business is increasing very rapidly and we want to avoid delays. Lewis & Co., Box 16, Capitol Station, Albany, New York.

ANNOUNCEMENTS

IT IS NOW POSSIBLE for you to secure the parts necessary to build electric toasters. Write today for circular and price list to the Practical Electrical Projects Co., Highland Park, Illinois.

Teaching Manual and Industrial Arts

By IRA S. GRIFFITH

*Professor of Industrial Education,
University of Wisconsin*

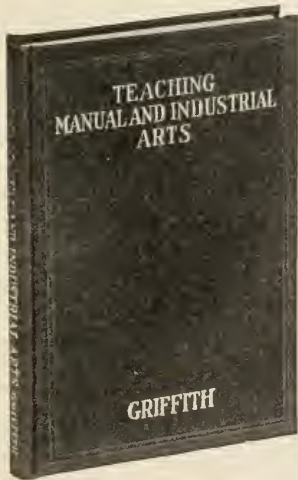

THIS VALUABLE BOOK sets forth clearly the best results of modern psychology as applied to the teaching of the manual and industrial arts. It is essentially a textbook for use in normal schools and colleges by prospective teachers, but is well adapted for reference use by all manual and vocational teachers now in service.

It presents the philosophy of teaching manual and vocational education in terms of psychology, social science and economics.

To the thoughtful teacher, whether beginner or experienced supervisor, this book is of special value. The student of general education, administrator or educational expert who is fair to himself and the manual and industrial arts will find new light in its discussions and to them it will prove a valuable source of information about the educational theory and practice.

Price, postpaid, \$2.00. Discount in Quantities

THE MANUAL ARTS PRESS

PEORIA - - - ILLINOIS



TEACHERS' AGENCIES



Why Join Us? A Bureau for Specialists—no elementary school subjects. The position you want, or nothing to pay. Manual Arts teachers placed in the best schools in America. Half of the State Universities selected our candidates. Emergency positions open. For a choice position, now or later, write us.

SPECIALISTS' EDUCATIONAL BUREAU **ODEON BUILDING**
ST. LOUIS, MISSOURI

TEACHERS NEEDED DAILY FOR BEST SCHOOLS

DENVER, COLORADO **FIISK TEACHERS AGENCY**
M. E. SHUCK, Ph. D. 1919, Manager (Experienced Educator)
Boston, New York, Pittsburg, Birmingham, Portland, Berkeley, Los Angeles

ALBERT TEACHERS' AGENCY 25 E. Jackson Boulevard, CHICAGO

37th year. Teachers of Manual Training and all Vocational work much in demand. Free registration. Best schools our clients. **Real Service.** Booklet free.

Other Offices: 437 Fifth Ave., New York; Symes Bldg., Denver; Peyton Bldg., Spokane

Vocational Teachers

Eventually you'll join our Exchange. Because we successfully promote Manual Training and Vocational Teachers to **Better Positions.**

FREE ENROLLMENT—ALL OFFICES—REGISTER NOW

WESTERN TEACHERS' EXCHANGE

CHICAGO, ILL. **DENVER, COLO.** **MINNEAPOLIS, MINN.** **BERKELEY, CALIF.**
Peoples Gas Bldg. Gas & Electric Bldg. The Plymouth Bldg. Berkeley Bank Bldg.

WE PLACE YOU IN THE BETTER POSITIONS



Our Reputation is National Our Service Unexcelled

Attention: Minimum requirements for registration two years work above the high school.

Branch Offices:

KANSAS CITY, MO., 230 RIALTO BUILDING
PORTLAND, OREGON, N.W. BANK BUILDING
MINNEAPOLIS, MINN., LUMBER EXCHANGE
LOS ANGELES, CALIF., PACIFIC MUTUAL BUILDING

WM. RUFFER, Ph. D., Manager
W. B. Mooney, A.M., Field Representative



YOUR OPPORTUNITY!!

Advancement offered in all types of educational positions. Our highly specialized service is fashioned for your promotion. Personal interest in each member a keynote. Surely, this is the agency you are looking for.

A. P. GODDARD *The coupon mailed today will bring you a "Free List of Vacancies"*
PRESIDENT

EDUCATORS-AGENCY

19 SOUTH LA SALLE STREET

ROOM 1421 Y. M. C. A. BLDG - CHICAGO, ILLINOIS

NAME _____

ST. & NO _____

CITY _____ STATE _____

M.T.

CLAY WORK

By KATHERINE MORRIS LESTER



A Manual and a practical help to teachers in acquiring the technique of clay working. It gives detailed descriptions of the processes of working and illustrates the work of pupils from ten to twelve years of age in the public schools.

POSTPAID, 70 CENTS

THE MANUAL ARTS PRESS
PEORIA, ILLINOIS



TEACHERS' AGENCIES



CLARK TEACHER'S AGENCY ^{33rd} YEAR

Each Office Has the Records of All—Address the Nearest—Free Registration

Chicago,
Steinway Bldg.

New York,
Flatiron Bldg.

Baltimore,
110 E. Lexington St.

Columbus, Ohio,
Ferris Bldg.

Minneapolis,
Globe Bldg.

Kansas City, Mo.,
New York Life Bldg.

Los Angeles,
California Bldg.

Spokane, Wash.,
Chamber of Com. Bldg.

NORTHWESTERN TEACHERS AGENCY

BOISE, IDAHO,
R. R. Alexander, Mgr.

DENVER, COLORADO,
S. S. Phillips, Mgr.

We Put the Ambitious Teacher—**THE COMER**—In touch with
the Boards **WILLING TO PAY**

ALL THE WEST AND ALASKA

ENROLL NOW

REGISTRATION FREE

NATIONAL EDUCATIONAL AGENCY

1215 STATE LIFE BUILDING INDIANAPOLIS, INDIANA

OUR MOTTO—SERVICE. We have openings ALL THE TIME for well-trained and progressive teachers. We will give intelligent service in finding the place for which you are best fitted.

Write us concerning the subject and salary desired and we will put you in immediate touch with calls corresponding to your desire.

MARY FRANCES WILSON.

Excellent Vocational Positions Open, for immediate appointment and for September, Salaries and location very desirable. No fee unless appointed, and NO REGISTRATION FEE.

Write today. OSWEGO TEACHERS AGENCY Box 27E, Oswego, N. Y.

INTERSTATE TEACHERS AGENCY

60 North Fitzhugh St., Rochester, N. Y.

Secures Positions in all Parts of the United States
for Teachers of Manual Arts

Write Today for Information

Apply today to

Represent this Magazine while you attend Summer School. An attractive proposition for one student in each school. Write at once before your school is taken.

THE MANUAL ARTS PRESS, Peoria, Illinois

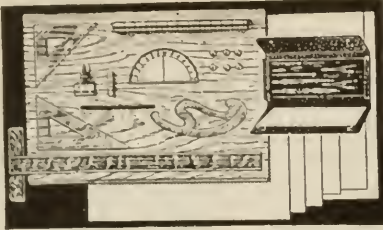

BEST QUALITY OF
DRAWING INSTRUMENTS

Consistent with prices within reach
of every student

COMPLETE LINE OF

T. Squares, Triangles, Scales,
Drawing Boards, Drawing Papers,
Pencils, Thumb Tacks, Etc.

Ask for Illustrations and Prices

THE OLD RELIABLE HOUSE
AMERICAN BLUE PRINT PAPER CO.
445 Plymouth Court, Chicago, Ill.



**Manual Training
Bench, No. 16**

which is furnished with one Abernathy Rapid
Acting Vise, and with one drawer.

Ask for our new Catalog No. 27

C. CHRISTIANSEN
BENCH MANUFACTURER
2814 W. 26th St. CHICAGO, ILL.

Buffalo Combination Woodworker

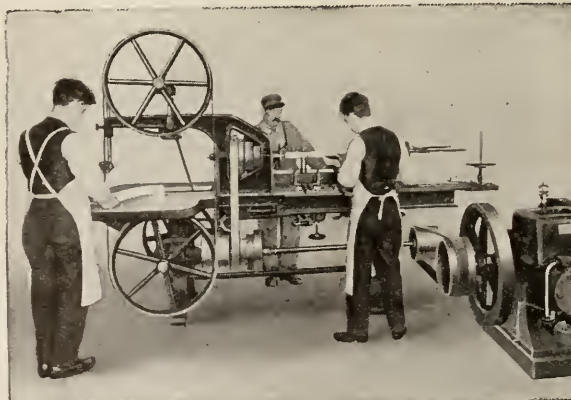

Twelve
machines
in one

Three
men
can work
at one
time
without
inter-
ference

With this machine it is possible to give a complete training in woodworking
without an elaborate machine equipment.

Bulletin 360 will show how a small appropriation
can be made to work wonders.

BUFFALO FORGE COMPANY
BUFFALO, NEW YORK

INDEX TO ADVERTISEMENTS

	PAGE		PAGE
<i>Band Saws</i>		South Bend Lathe Works	
The Crescent Machine	3rd Cover	
Co.	xxx1	Champion Tool Works, xxiii	
The Parks Ball-Bearing		American Wood Working	
Machine Co.	xxiii	Machinery Co., 4th Cover	
Oliver Machinery Co.		J. A. Fay & Egan Co.	xiii
.....i, xxvii, xxxiii		Little Giant Co.	xv
American Wood Working		Oliver Machinery Co.	
Machinery Co., 4th Cover	i, xxvii, xxxiii	
<i>Benches</i>		<i>Lumber</i>	
Kewaunee Mfg. Co.	xlii	Maisey and Dion.	xix
C. Christiansen.	xxxvii	Frank Paxton Lumber	
<i>Books</i>		Co.	xxix
McGraw-Hill Co.	xviii	John S. Benedict Lumber	
John Wiley & Sons, xxiv, xxvi		Co.	xxv
The Manual Arts Press.	ii, xxxii, xxxv, xxxvi, xxxvii, xl	The Pacific Lumber	
<i>Cabinet Hardware</i>		Co.	xxvii
Hammacher, Schlemmer		A. R. Vinnedge & Co.	xxxiii
& Co.	xxii	<i>Metalworking Tools</i>	
Thurston Manual Training		The L. S. Starrett Co.	ix
Supply Co.	xxx1	Vaughan & Bushnell Mfg.	
<i>Clamps</i>		Co.	xix
Adjustable Clamp Co.	xxv	Hammacher, Schlemmer &	
<i>Crayons</i>		Co.	xxii
American Crayon Co.	xxv	Little Giant Co.	xv
<i>Drawing Supplies</i>		Western Tool and Manu-	
American Blue Print		facturing Co.	xxiii
Paper Co.	xxxviii	<i>Mortisers</i>	
Eugene Dietzgen Co.	xxv	J. A. Fay & Egan Co.	xiii
<i>Drawing Instruments</i>		Oliver Machinery Co.	
Eugene Dietzgen Co.	xxviiii, xxvii, xxxiii	
American Blue Print		<i>Pencils</i>	
Paper Co.	xxxviii	Joseph Dixon Crucible	
<i>Forges</i>		Co.	xx1
Buffalo Forge Co.	xxxviii	<i>Phonographs</i>	
<i>Foundry Equipment</i>		Choraleon Phonograph	
George A. Ross.	xxxiii	Co.	xxix
<i>Furniture Designs</i>		Hoosier Manufacturing	
Choraleon Phonograph		& Supply Co.	xxx
Co.	xxix	<i>Planes</i>	
Hoosier Manufacturing &		The Stanley Rule & Level	
Supply Co.	xxx	Plant.	xxviii
<i>Hammers</i>		Vaughan & Bushnell	
Vaughan & Bushnell Mfg.		Manufacturing Co.	xix
Co.	xix	<i>Printing Outfits</i>	
The David Maydole		Barnhart Bros. &	
Hammer Co.	xxx1	Spindler.	xxv
<i>Hard-to-get Materials</i>		<i>Rules</i>	
Thurston Manual Training		Lufkin Rule Co.	xxx1
Supply Co.	xxx1	The Stanley Rule & Level	
<i>Jointers</i>		Plant.	xxviii
American Wood Working		<i>Sanders</i>	
Machinery Co., 4th Cover		J. A. Fay & Egan Co.	xiii
J. A. Fay & Egan Co.	xxiii	<i>Sawing Machinery</i>	
Oliver Machinery Co.		Oliver Machinery Co.	
.....i, xxvii, xxxiii	i, xxvii, xxxiii	
<i>Knives</i>		Alexander Dodds Co.	xxvii
R. Murphy's Sons Co.	vii	The Crescent Machine	
<i>Laboratory Furniture</i>		Co.	xxx1
The Kewaunee Mfg. Co., xlii		The Tannewitz Works.	xxix
Weise Laboratory Furniture		The Parks Ball Bearing	
Co.	xvii	Machinery Co.	xxiii
<i>Lathes</i>		J. A. Fay & Egan Co.	xiii
The Monarch Machine		<i>Saws</i>	
Tool Co.	xx	Henry Disston & Sons.	iv
The Sidney Machine		Simonds Manufacturing	
Tool Co.	xvii	Co.	xxx
Rockford Lathe & Drill		<i>Schools and Colleges</i>	
Co.	xix	Carnegie Institute of	
		Technology.	xviii
		<i>Teacher's Agencies</i>	
		Clark Teacher Agency xxxvii	
		Interstate Teachers	
		Agency.	xxxvii
		Specialists' Educational	
		Bureau.	xxxvi
		Oswego Teachers' Agency	
		xxxvii
		Albert Teachers' Agency	
		xxxvi
		Fisk Teachers' Agency, xxxvi	
		Western Teachers'	
		Exchange.	xxxvi
		Rocky Mt. Teachers'	
		Agency.	xxxvi
		Educators-Agency.	xxxvi
		National Educational	
		Agency.	xxxvii
		Northwestern Teachers	
		Agency.	xxxvii
		<i>Tool Grinders</i>	
		Mummert-Dixon Co.	xxix
		<i>Type</i>	
		American Type Founders	
		Co.	xi
		<i>Upholstery</i>	
		Thurston Manual Training	
		Supply Co.	xxx1
		Illinois Valley Awning &	
		Tent Co.	xxxiii
		<i>Vises</i>	
		Greenlee Bros.	xlii
		The Western Tool &	
		Manufacturing Co.	xxiii
		<i>Wood Finishes</i>	
		S. C. Johnson & Son	
	2d Cover.	
		<i>Woodworking Machinery</i>	
		Little Giant Co.	xv
		J. A. Fay & Egan Co.	xiii
		The Sidney Machine Tool	
		Co.	xxvii
		Oliver Machinery Co.	
	i, xxvii, xxxiii	
		Alexander Dodds Co.	xxvii
		The Crescent Machine	
		Co.	xxx1
		The Parks Ball Bearing	
		Machine Co.	xxiii
		American Wood Working	
		Machinery Co., 4th Cover	
		The Tannewitz Works, xxix	
		<i>Woodworking Tools</i>	
		Henry Disston & Sons.	iv
		R. Murphy's Sons Co.	vii
		The L. S. Starrett Co.	ix
		Vaughan & Bushnell	
		Mfg. Co.	xix
		The Stanley Rule &	
		Level Plant.	xxviii
		Hammacher, Schlemmer &	
		Co.	xxii
		Montgomery & Co.,	
		Inc.	xxiv
		Greenlee Bros.	xlii
		Mummert Dixon Co.	xxix
		Simonds Manufacturing	
		Co.	xxx
		Syracuse Twist Drill	
		Co.	xxvii

A Text for Every Grade

FOR SEVENTH AND EIGHTH GRADES

- Woodwork for Beginners—GRIFFITH.....32 cents
A successful text for grade classes. (Also in cloth at 50 cents).
- Grammar Grade Problems in Mechanical Drawing—BENNETT.....36 cents
A successful text and the only one published for grade classes.

FOR GRAMMAR GRADES OR JUNIOR HIGH SCHOOLS

- Workshop Note Book—Woodworking—GREENE.....22 cents
A text and note book combined—Full of helps, ideas and suggestions.
- Tool Processes in Woodworking—LAUGHLIN.....76 cents
A text and reference book especially suited to ambitious boys.
- Essentials of Woodworking—GRIFFITH.....\$1.24
The standard textbook for beginning classes.
- Mechanical Drawing for Beginners—BAILEY.....44 cents
Condensed yet simple treatment of fundamentals.
- Problems in Mechanical Drawing—BENNETT.....\$1.20
Unsolved problems—good selection—carefully graded.
- Practical Electricity for Beginners—WILLOUGHBY.....\$1.00
Fundamental facts in very simple form with application to common electrical articles.

FOR HIGH AND VOCATIONAL SCHOOLS

- Woodwork for Secondary Schools—GRIFFITH.....\$2.00
Most complete and comprehensive textbook on woodworking ever published.
- Carpentry—GRIFFITH.....\$1.50
A textbook on frame house construction for students and apprentices.
- Mechanical Drawing Problems—BERG & KRONQUIST.....\$1.28
A wonderful collection of problems admirably presented. Covers two years work.
- Mechanical Drafting—MILLER.....\$2.00
Practical drafting room practice for advanced students.
- Elementary Forge Practice—HARCOURT.....\$1.50
Good clear text—well selected projects with the best presentation available in textbook form.
- Elementary Machine Shop Practice—PALMATEER.....\$1.50
Practical text, not too advanced and not too elaborate.
- Sheet Metal Pattern Drafting & Shop Problems—DAUGHERTY.....\$2.50
A complete, practical course by an authority.

*Ask for catalog describing our complete line of text
and reference books on industrial education.*

THE MANUAL ARTS PRESS

PEORIA, ILLINOIS



BOOK NOTES

THE series of articles by A. H. Edgerton that have been running in this Magazine during the past three months have proven to be so valuable that they are now being issued in pamphlet form by The Manual Arts Press under the title *Industrial Arts in our Elementary Schools*. This pamphlet will be ready for use about June 10th—in time for summer-school classes. For several years there has been a great deal of experimenting going on in the teaching of industrial arts in the lower grades. There has been a feeling that the older lines of work were not adequate to meet new conditions, including new educational ideals. On the other hand, there has been a great deal of doubt whether many of the proposed changes in this section of school work were practical under ordinary public school conditions. Professor Edgerton's articles constitute the best answer to these doubts that has been formulated, because they show what particular kinds of work have been done successfully. They are based on a summary of answers from 141 school systems and are made up quite largely from signed statements made by teachers in various schools. The pamphlet is a storehouse of suggestions for teachers in grades from I to VI inclusive.

THERE is a constant demand for more problems in woodworking for use in the grammar grades and in the high schools. The idea that it is undesirable to have pupils make "the same old models" year after year has come to prevail, but the teacher who has large classes and many of them—who has not been able to get his school principal to adopt the intensive plan of Newark, New Jersey—finds difficulty in providing a sufficient number of new problems himself or in getting the boys to provide them, without interfering with the orderliness and progress of his instruction, and so he looks about for some new publication to give him help. For such teachers The Manual Arts Press has good news. There is now going thru the process of editing an exceptionally fine collection of problems by Harold R. Wise of Providence, Rhode Island. As is already known to readers of this Magazine, Mr. Wise is an excellent draftsman and designer of woodworking projects. He is also a thoro teacher and a student of educational methods. His new collection of problems will be a worthy successor in the line started by M. W. Murray in his *Problems in Woodworking* and followed a few years later by Ira S. Griffith in

Projects for Beginning Woodwork and Mechanical Drawing. This new series by Mr. Wise will reflect some of the changes in grammar grade woodwork that have taken place since the other two were issued. The book will be ready in time for use in September. Probably it will be completed in July.

IT seems to be true that there are many more teachers in the grammar grade woodworking classes who would like to use a text-book than can induce their boards of education to adopt a satisfactory book. The reason the boards refuse to adopt a text-book is usually because books cost money and the board is neither willing to spend the required money nor to force the parents to pay it. To meet this situation The Manual Arts Press has issued a paper covered edition of Griffith's *Woodwork for Beginners* which it now offers for 32 cents, with the usual discount in quantities. It still has the hard bound edition at 50 cents, but if wear is not a serious consideration, and if the teacher will guard against the misuse of a paper-bound volume, he can have the very great help of this excellent book at such a low cost that it would seem the expense should no longer prevent its use. If a teacher can have in the hands of each pupil this new edition of Griffith's *Woodwork for Beginners*, and at each bench a copy of Bennett's *Grammar Grade Problems in Mechanical Drawing*, and the new book of problems by Harold Wise, he will be well equipped with grammar grade text material at the lowest cost.

THE following is from a review of Greene's *School Shop Installation and Maintenance* in the May number of the *School Review*:

"Professor Greene in a new book brings together, for the first time, material selected from technical sources and from his own experience which will be of distinct value to school authorities responsible for the installation of a new shop equipment or with the reorganization of old equipment.

"As a result of the author's efforts there is presented an ample collection of valuable data and calculations required to install successfully the various metal and woodworking machines. Practical problems involving the use of such data are brought up, and solutions worked out. The use of complex formulas has been avoided, and those which are given are amplified in such a way as to make them readily usable."

GREENLEE No. 560



An Ideal Jointer for Cabinet or Pattern Shop

Can be mounted on a bench or furnished with pedestal base as shown. The latter arrangement is very convenient for motor drive, and provides a splendid piece of equipment when fitted with safety knife guard and wire mesh belt guard.

The head is of the safety cylindrical type with 6½-inch knives. The tables are 41½ inches long overall and 8 inches wide.

Greenlee machines are built for real service in commercial shops. That is why they are most satisfactory for school purposes.

Ask for circulars on Jointers, Mortisers, Tenoners and Variety Saws

GREENLEE BROS. & CO. ROCKFORD, ILL.

Kewaunee

Manual Training Furniture

TH**ERE** is a great difference in Manual Training Furniture, as any instructor will admit who is familiar with Kewaunee. When once installed, the superiority of Kewaunee is readily recognized by pupils as well as teachers.



A recent letter from E. M. Block, Supt. of Schools, Healdton, Okla., follows:

"We installed the Kewaunee furniture in our Domestic Science and Manual Training departments in September, 1919. Soon afterwards the building with all the furniture was destroyed by fire. We liked Kewaunee furniture so well that when our new building was ready to be equipped, we did not consider any other sort. All of our Science departments are equipped with Kewaunee furniture because we are convinced that it is the best. We heartily recommend it to any Superintendent or Board of Education desiring a high grade of furniture."

Kewaunee Laboratory Furniture is built for the better schools. If you are planning new equipment, ask for a copy of the Kewaunee Book. It is FREE. Address all inquiries to the factory at Kewaunee.

Kewaunee Mfg. Co.
LABORATORY FURNITURE EXPERTS

111 Lincoln St., Kewaunee, Wis.
New York Office, 70 Fifth Avenue

Branch Offices:

Chicago Minneapolis Kansas City Columbus Denver
Baton Rouge Houston Little Rock Spokane Phoenix
San Francisco Omaha Oklahoma City Jackson, Miss.
Albuquerque Salt Lake City Toronto Greensboro, N. C.

