

**UNITED STATES
CIVIL DEFENSE**

**Interim Guide for
the Design of Buildings
Exposed to Atomic Blast**

TM-5-3



P.D.
FCD 1.6/3;
5-3/2

FEDERAL CIVIL DEFENSE ADMINISTRATION

Interim Guide for the Design of Buildings Exposed to Atomic Blast is one in a series of technical manuals prepared by the Federal Civil Defense Administration. These manuals provide detailed technical or specialized information in particular fields of civil defense.

This publication, intended primarily for architects and engineers, describes briefly the effects of atomic explosions on buildings; suggests methods of increasing the strength of new buildings; and points out hazards which should be considered in the design of shelter areas in buildings.

Observations of damage at Hiroshima and Nagasaki indicate that a number of relatively inexpensive structural details can be adopted in new construction to increase blast resistance of buildings and, at the same time, offer more protection to occupants and critical equipment and materials. Further, there are a number of incidental hazards that can be reduced or eliminated.

Since recommended loadings are based on current knowledge and subject to change by additional experience, this publication can be considered only a guide until more complete design information is available.

This manual is based primarily on material contributed by Dr. Robert J. Hansen of the Massachusetts Institute of Technology and Dr. Merit P. White of the University of Massachusetts in cooperation with Mr. Sherwood B. Smith, Technical and Scientific Advisor, Armed Forces Special Weapons Project, Department of Defense. Grateful acknowledgment is made for this work and for the contributions of a panel of specialists which reviewed the material in this publication. (See inside of back cover.)

From the collection of the

Prelinger
Library

San Francisco, California
2008

Interim Guide for the Design of Buildings Exposed to Atomic Blast is one in a series of technical manuals prepared by the Federal Civil Defense Administration. These manuals provide detailed technical or specialized information in particular fields of civil defense.

This publication, intended primarily for architects and engineers, describes briefly the effects of atomic explosions on buildings; suggests methods of increasing the strength of new buildings; and points out hazards which should be considered in the design of shelter areas in buildings.

Observations of damage at Hiroshima and Nagasaki indicate that a number of relatively inexpensive structural details can be adopted in new construction to increase blast resistance of buildings and, at the same time, offer more protection to occupants and critical equipment and materials. Further, there are a number of incidental hazards that can be reduced or eliminated.

Since recommended loadings are based on current knowledge and subject to change by additional experience, this publication can be considered only a guide until more complete design information is available.

This manual is based primarily on material contributed by Dr. Robert J. Hansen of the Massachusetts Institute of Technology and Dr. Merit P. White of the University of Massachusetts in cooperation with Mr. Sherwood B. Smith, Technical and Scientific Advisor, Armed Forces Special Weapons Project, Department of Defense. Grateful acknowledgment is made for this work and for the contributions of a panel of specialists which reviewed the material in this publication. (See inside of back cover.)

UNITED STATES CIVIL DEFENSE

INTERIM GUIDE FOR
THE DESIGN OF BUILDINGS
EXPOSED TO ATOMIC BLAST



FEDERAL CIVIL DEFENSE ADMINISTRATION
(Technical Manual)

UNITED STATES GOVERNMENT PRINTING OFFICE : JUNE 1952

CONTENTS

<i>Chapter</i>	<i>Page</i>
1. Effects of an atomic explosion	1
Air blast	1
Radiation	2
Comparison of building types	4
The design problem	8
2. Methods for making structures stronger	11
Advantage of consistent strength	11
Design for lateral and vertical blast loads	11
Relation between static strength and dynamic behavior	15
Influence of shape and size of structure	19
The effect of internal pressure	20
3. Minimizing hazards	24
Utilities	24
Ceiling fixtures and other missiles	24
Fire	24
Radiation	25
Glass	25
Exits	26
4. Design of protected areas in buildings	27
Location	27
Blast and debris walls, and horizontal slabs	27
The protective core	28
Conclusions	29
<i>Appendix</i>	
Official civil defense publications	31

EFFECTS OF AN ATOMIC EXPLOSION

1.1 When an atomic bomb explodes, a tremendous amount of energy is released in an extremely short time. If the bomb explodes in air, this energy appears as kinetic energy transmitted to the surrounding air, and radiant energy in such forms as gamma rays, nuclear particles, and heat. A bomb exploding underground or underwater transmits much of its kinetic energy to the surrounding medium while some is given to the air above the point of explosion. The relative amount transmitted depends on the depth at which the bomb detonates. Underground structures may be damaged by pressures transmitted through the earth. Those extending above ground will be shaken, as in an earthquake, and also will be subjected to air blast. Underwater explosions will produce strong shock waves.¹

Air Blast

1.2 Energy released from an air-bursting atomic bomb produces a powerful pressure wave which travels radially from the center of explosion, enveloping all objects in its path. The intensity of pressure diminishes with distance from the point of explosion. For the nominal 20-KT bomb (equivalent to 20,000 tons of TNT), the blast effects are still severe at a mile; will damage houses at more than 2 miles; and are detectable for several miles from the point of explosion. In figure 1, the pressure-time curve of the blast wave shows an initial abrupt rise in pressure, gradually decreasing to zero in about 1 second, and then a much less intense suction phase lasting for several seconds. The effect of such a pressure wave on a building is that of a heavy blow followed by a more or less steady force. This force acts first on the side of the building nearest the explosion; then, as the blast wave passes, on the remaining sides and roof, creating a giant squeeze. After the front of the blast wave has passed over the building there remains a drag force on the structure, directed away from the point of explosion. The drag force is the result of the very strong wind that follows the shock front, and decreases to zero when the blast pressure becomes zero. At the start of the suction phase, the force on the building reverses direction and acts toward the point of explosion. Figure 1 also shows the damage that may be inflicted on two types of buildings. Deflections of the framed building are exaggerated for purposes of illustration.

¹ *The Effects of Atomic Weapons*, Department of Defense and Atomic Energy Commission, June 1950.

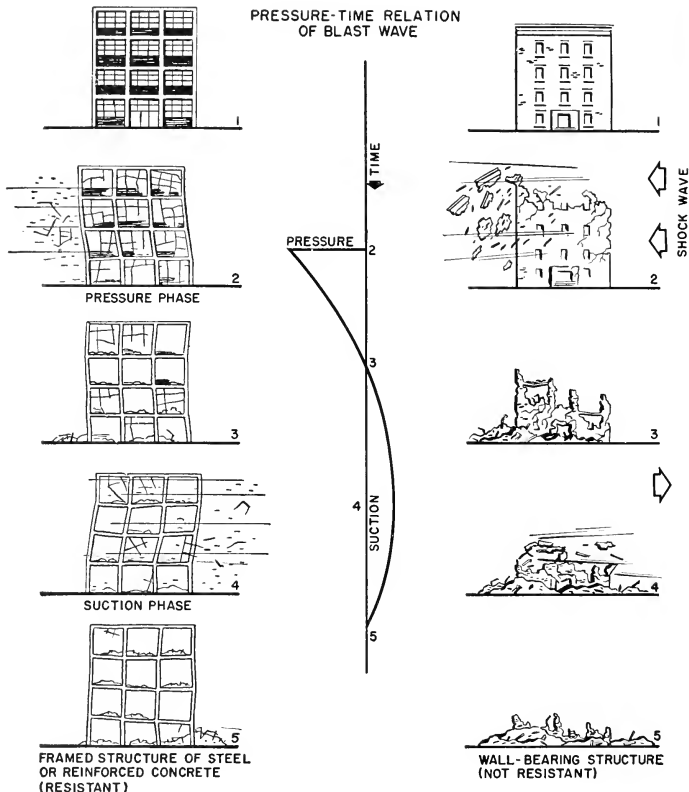

FIGURE 1.—Relative resistance of two types of structures to atomic blast.
(Taken from civil defense manual, State of Massachusetts.)

Radiation

1.3 Nuclear radiations released in an atomic explosion have no damaging effect on buildings but may be harmful to exposed persons. Figure 2 shows that at 3,000 feet from an airbursting nominal atomic bomb these radiations will prove fatal to about 50 percent of human beings even when shielded by 12 inches² of concrete. If no shielding is provided, the radiation dose at about 4,200 feet is sufficient to cause fatal injuries to about 50 percent of human beings exposed. Beyond 7,000 feet, however, the nuclear radiation dose is virtually harmless to people.

²This dimension is the slant thickness along a line to the point of burst.

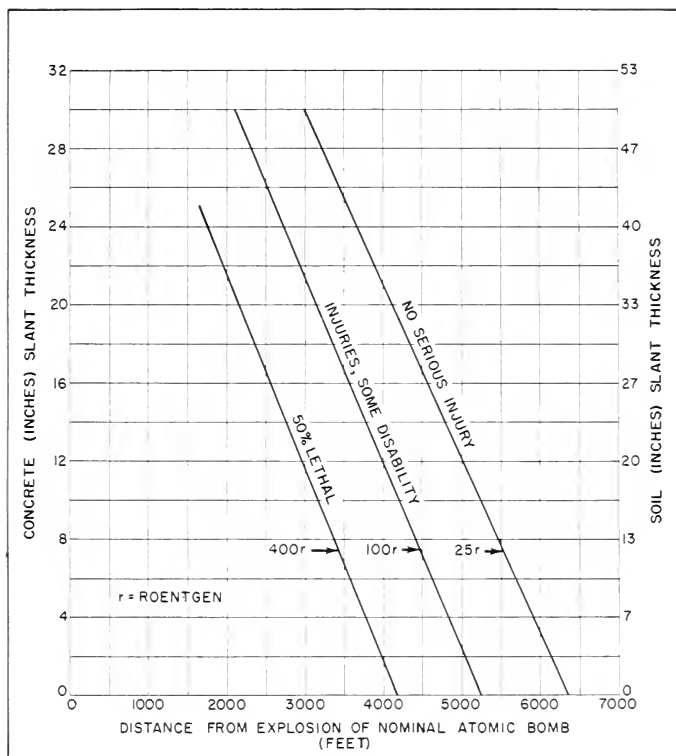

FIGURE 2.—Reduction of nuclear radiation hazard by shielding.

1.4 Thermal radiation from an atomic explosion constitutes a serious hazard for people in unshielded areas. However, the amount of protection required for shielding is small, and almost any non-transparent material is adequate.

1.5 Heat radiated from the explosion travels with the speed of light, striking all exposed objects in the line of sight from the explosion. This heat, or flash, will char wood surfaces at distances up to two miles from the point of burst and set highly flammable materials afire. Ignition of paper, light cotton cloth, and other similar materials is possible, but the burning of such objects will not cause a mass fire unless it can spread to other combustible materials.

1.6 In addition to fires initiated directly by thermal radiation, there exists another grave fire danger. As demonstrated at Hiroshima and Nagasaki, fires can be set and spread by secondary effects.



FIGURE 3.—Light, steel-frame industrial building, 1,800 feet from ground zero (ground point directly beneath the explosion). Corrugated iron roof and wall sheathing were stripped by the blast, and the combustible contents destroyed by fire.

such as overturned furnaces and stoves, electrical short circuits, and broken gas lines.

Comparison of Building Types

1.7 The records of damage at Hiroshima and Nagasaki show clearly the manner in which building types vary in their ability to resist the blast and fire effects of an atomic explosion. (See figs. 3, 4, 5, and 6.)³ Ability to resist lateral forces, to accept plastic deformation (i. e., beyond the elastic limit), and to withstand fire are the most important criteria for structural adequacy. In addition, the necessary material thickness to shield people against deadly nuclear radiation is a prime factor. The resistance of a building to lateral and vertical loads depends not only on the massiveness of the structure but also on the resilience and ductility of the frame, the strength of the beam and column connections, the number of supports in addition to those required for stability, and the amount of diagonal bracing or stiffening afforded by walls, partitions, and floors.

1.8 The most resistant buildings are steel- or reinforced-concrete-framed fireproof structures. The least resistant are shed-type com-

³These illustrations are reprinted from *The Effects of Atomic Weapons*, Department of Defense and Atomic Energy Commission, June 1950.

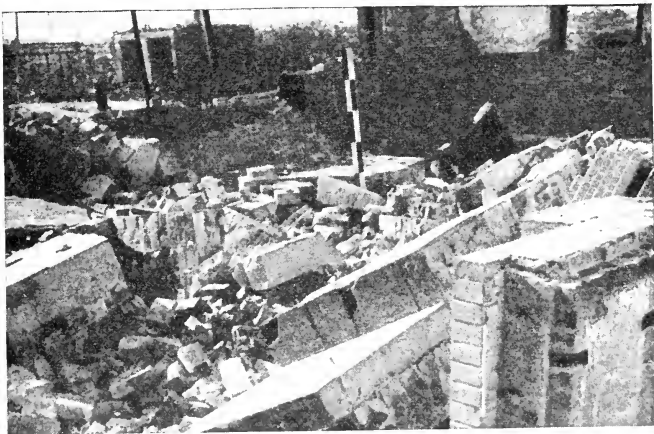
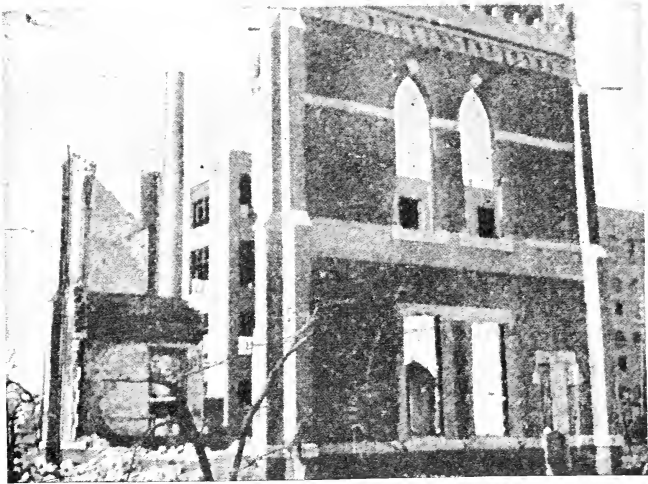

FIGURE 4.—*Upper photo:* Building with load-bearing walls, 5,200 feet from ground zero. Load-bearing wall away from the blast collapsed. *Lower photo:* Interior of same building, showing damage from blast and fire.

mercial or industrial structures having light frames with long span beams, and certain types of lightly built residential structures. Well-constructed and braced wood-frame residences show good resistance to blast from high explosive bombs, and, presumably, to blast from

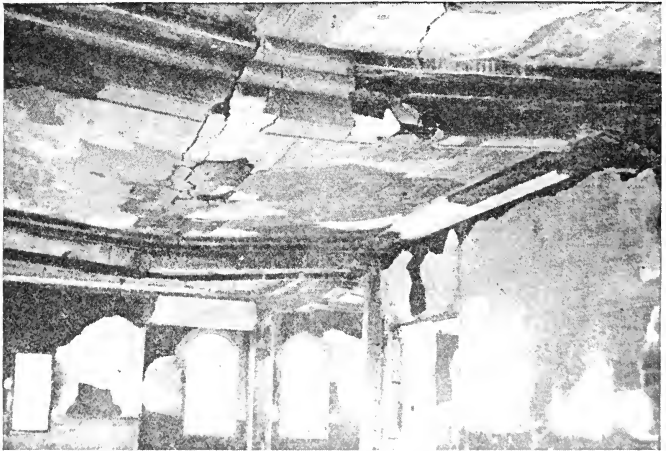
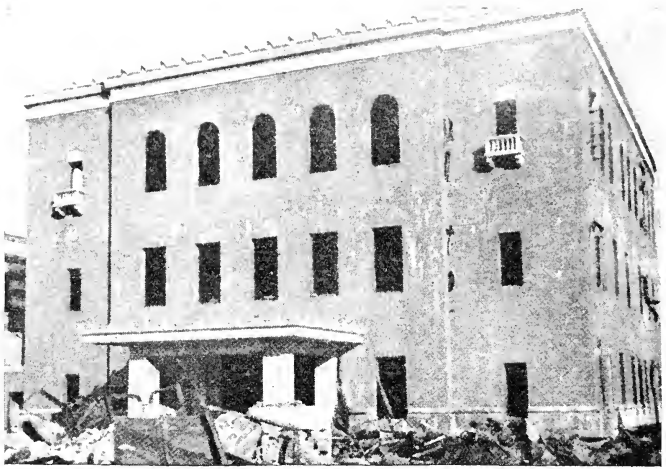

FIGURE 5.—*Upper photo:* Reinforced-concrete framed building, 700 feet from ground zero, 2,100 feet from point of explosion; external walls of concrete with brick tile facing intact. *Lower photo:* Interior of same building burned out; note sagging of roof and spalling of plaster by fire.

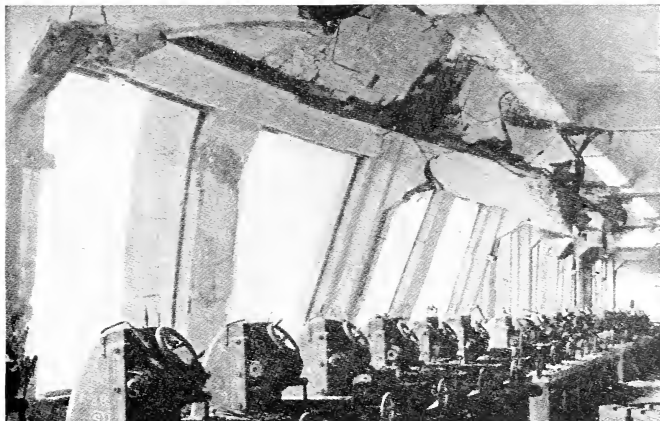

FIGURE 6.—Second floor of reinforced-concrete framed building, 1,900 feet from ground zero, showing fractured third-floor beams, and failure of columns at windows.

atomic bombs. The blast resistance of wall-bearing⁴ structures is very poor, as a result of lack of resilience and relatively low strength under lateral loads. Estimates of the comparative strength of buildings can be obtained from figure 7 which shows damage effects on various types of buildings in relation to distance from ground zero.

1.9 The order of preference for blast resistance is roughly as follows:

(a) *Reinforced-concrete and heavy steel-framed multistory buildings designed for wind or earthquake resistance.*—These buildings have continuous connections from columns to beams and slabs, either by means of reinforcing steel or by riveted or welded connections. All parts of the structure are, therefore, rigidly connected. Masonry curtain walls may be expected to fail, unless they have been reinforced and tied to the structural frame. Japanese earthquake-resistant design requirements are more severe than those in the United States because of more frequent and violent earthquakes in that country. Consequently, multistory buildings in Japan are more resistant than similar types of structures in this country.

(b) *Industrial buildings with continuous steel frames rigidly connected and strongly braced in all directions.*—These buildings are likely to have light coverings, such as corrugated sheets, which may easily be blown away or broken.

⁴ The terms "masonry" or "masonry walls" when used in this manual refer to walls of unreinforced brick, tile, or blocks.

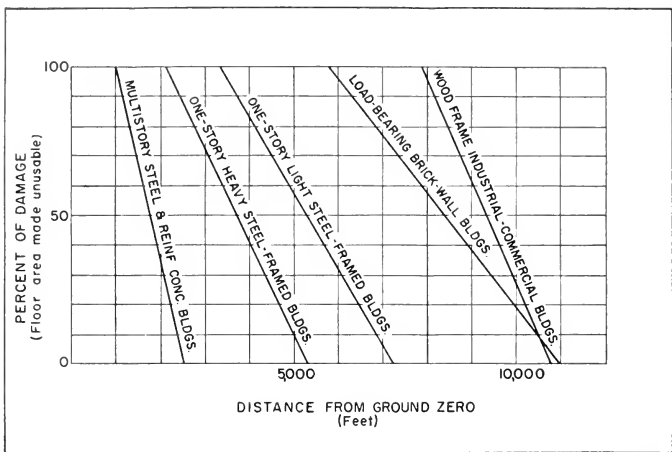

FIGURE 7.—Damage at Hiroshima and Nagasaki from nominal atomic bomb. (Reprint from Engineering News Record, 26 Jan. 1950.)

(c) *Strongly braced wooden frame houses that are relatively low and wide.*—Diagonally sheathed houses are relatively strong. Corner braces are helpful, but many are so poorly placed and connected that their value is doubtful. Large glass areas are vulnerable but in shattering may lessen the load on the structure.

(d) *Light shed-type commercial and industrial buildings with long-span trusses and beams, light columns, and little lateral bracing with large areas exposed to blast.*—These buildings are easily pushed over.

(e) *Masonry wall-bearing structures with ordinary floor, beam and column, or bearing partition construction.*—These buildings are especially vulnerable to blast.

(f) *Tall, light wood-frame buildings such as three-decker flats.*—Height, lack of strong frames, and poor bracing in the walls make these buildings especially vulnerable to blast and fire.

The Design Problem

1.10 The dynamic nature of blast loading and the resulting structural response makes the design of a building to resist blast effects a new and difficult problem. The purpose of this manual is to indicate the general nature of the problem resulting from an atomic explosion, and the general steps that engineers can take until a more complete design manual is available.

1.11 As described previously, the blast from an atomic explosion applies a very large force very suddenly to the side of a structure facing the blast. The pressure on this side then drops very rapidly while the other sides and roof of the structure acquire smaller loads.

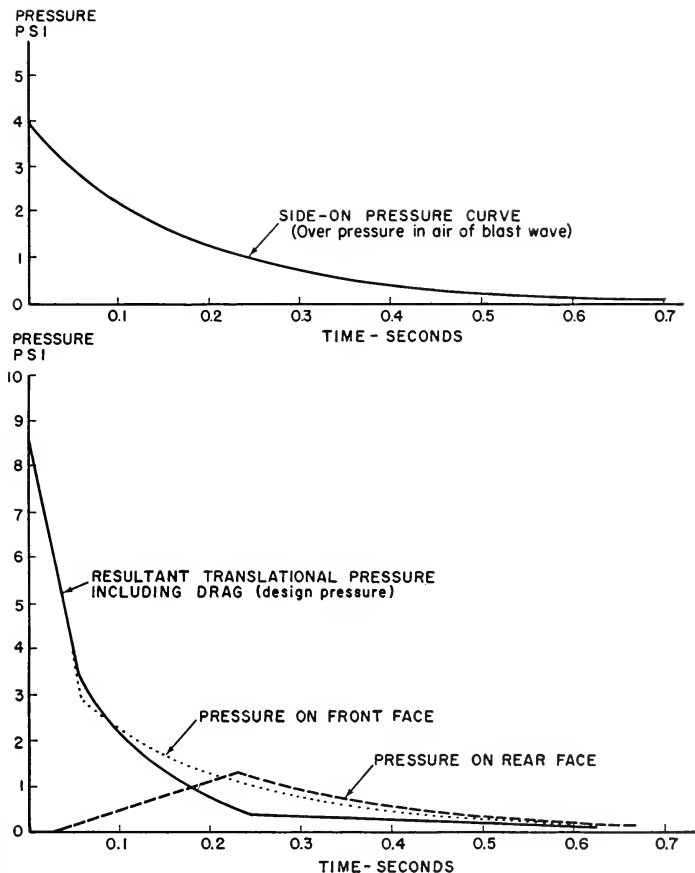

FIGURE 8.—Pressure curves for hypothetical structure.

The wind which follows the shock front exerts drag or aerodynamic forces on the structure. The loading is affected by the intensity of the shock wave (depending on the location and the strength of the explosion), the size and shape of the structure, and the behavior of the structure, that is, whether or not there are windows or breakable panels in the walls. The prediction of the actual forces and their time variation is too complicated to be discussed in a manual of this limited scope.

1.12 Figure 8 illustrates estimated idealized dynamic loading patterns for a two-story hypothetical structure—40 feet deep and 24

feet high, and of length at least twice the height—located in the 4-psi region of a nominal atomic bomb blast. The response of the structure to these dynamic loads is difficult to calculate. Because the intense initial loading is of very short duration, its effect is very much less than if it were to remain on the structure indefinitely. An analysis based on dynamic behavior is needed for a complete study of structural response to blast loads. In practice, consideration of plastic structural action is frequently necessary and introduces another complication into the design problem. Such calculations for pressure levels of 2.5, 3.4, and 4.7 psi have been made for the structure described in paragraph 2.20 and shown in figure 11. The results are discussed in "Relation Between Static Strength and Dynamic Behavior", page 15.

METHODS FOR MAKING STRUCTURES STRONGER

Advantage of Consistent Strength

2.1 The aim of blast-resistant construction is to minimize damage to structures and to offer partial or complete protection to occupants and contents of buildings from the blast, radiation, and fire effects of an atomic explosion.

2.2 Estimates of damaging effects of the bomb must be made and considered in the design problem. Since all the effects and possible hazards cannot be delineated with any high degree of accuracy at this time, the best that can be done is to describe the more important effects and hazards and suggest possible solutions.

2.3 No weak structural element should be present which will permit collapse before other parts of the structure are brought to full capacity. The following paragraphs in this chapter describe considerations that should be taken into account.

Design for Lateral and Vertical Blast Loads

OVER-ALL STRENGTH

2.4 The principal effects of blast on a structure are horizontal loading on the side facing the explosion, and to a lesser extent on the other sides, and vertical loading on the roof. The actual loads are of short duration but their effects are generally equivalent to those of steady loads of much smaller intensities acting laterally and vertically. This is approximately the situation with respect to earthquake-resistant design. Although an earthquake exerts dynamic forces on structures, the complicated seismic forces should be replaced in the design problem by empirical static loadings which can be treated by the usual methods of structural analysis. Structures designed by this method are of consistent strength and have resisted earthquake loadings satisfactorily. Structures designed without provision for wind loads ordinarily will be of inconsistent strength for lateral loadings, such as those resulting from atomic explosions. Since wind forces do not have much effect on the design of members, even those structures designed for nominal wind load may be of inconsistent strength, except in especially tall structures and in localities where wind forces are large. Therefore, the resistance of most structures is not uniformly consistent, since certain parts are much weaker than others. Earthquake-resistant buildings at Hiroshima and Nagasaki effectively resisted blast loading. Thus,

for increasing blast resistance, a design procedure somewhat similar to seismic design is tentatively recommended.

2.5 There are certain important basic differences between the problems of seismic design and blast design. Generally, an earthquake produces forces that increase with an increase in the weight of a structure. Consequently, earthquake-resistant structures, especially tall buildings, should be made as light as possible. On the other hand, for blast resistance, mass is helpful and reduction of weight generally undesirable. A comparison of the approximate design methods for blast- and earthquake-resistant structures shows that over-all seismic loads are proportional to weight, while over-all blast loads are proportional to the areas exposed.

2.6 Another difference between seismic and blast design is the treatment of individual members and their relation to the structure as a whole. In seismic design, the same lateral force factor—ratio of load to weight—is used for each element as for the entire structure, except that factors are made larger for the higher stories of multi-story buildings and for especially dangerous elements, such as chimneys or parapets. In blast design, only those elements exposed to unbalanced forces are affected. Moreover, the equivalent loading can be expected to depend on the character of the loaded element—quick-acting members, such as walls or slabs, will be subjected to larger unit loadings than the structure as a whole.

2.7 In the design of framing and roof, the equivalent static lateral forces recommended in table 2, page 30, should be applied successively to all faces of the structure, since blast may come from any direction.⁵ These loads are treated essentially like wind loads. They are assumed to act on exterior walls and to be transferred from these walls to the floor and roof systems. Floors and roof are treated like very deep beams loaded in the horizontal plane by the forces from the front walls and supported by bents or shear walls at certain intervals. (See fig. 9.) Bents or shear walls, in turn, transfer loads that they receive from floors and roof to the foundation. Working stresses allowed for wind loads should be used when the resistance is being calculated.

⁵ Normally, a structure whose framing members are designed to resist a lateral force corresponding to 90 psf actually will have much greater lateral resistance, due to the contributions of partitions, etc. The amount of these contributions is difficult to estimate. The recommended 90 psf for over-all structural design is of the same order of magnitude as the seismic loadings used in designing Japanese structures that showed good resistance to the Hiroshima and Nagasaki bombs. The designer must realize that he can increase or decrease the resistance of a building by using larger or smaller design loads than those recommended. The use of lateral loads in the design will result in fairly consistent strength among the various elements of the structure and permit greater distortion without collapse. The building should be designed to resist some lateral load applied successively to each side.

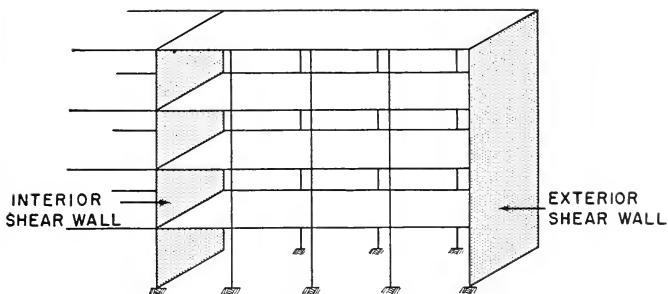

FIGURE 9.—Shear walls.

2.8 A design developed on this basis will give reasonable probability of survival (partial damage) to structures more than one-half mile from a 20-KT atomic bomb. A more powerful bomb will cause damage over a greater distance. However, doubling the power of the bomb will not double this distance, but will increase it only by about 25 percent.

2.9 Information in the preceding paragraphs can be applied to certain types of industrial buildings provided they contain a sufficient number of permanent partitions. Industrial structures of the mill-building type will be considered separately because of their importance and special features. Ordinarily, these structures have generally light walls and roof coverings and fairly long spans, and few, if any, shear-resistant walls and partitions. If the framing is heavy with moment-resistant connections, this type of building will be quite blast resistant. If the framing is light, the building will have little lateral strength.

2.10 Damage to lightly framed mill buildings can be reduced by:

(a) Using light, breakable wall and roof coverings such as asbestos or gypsum sheet, in preference to metal or masonry.

(b) Placing shear panels, diagonal bracing, knee braces or moment connections in all bents.

(c) Bracing horizontally in the plane of the eaves or roof.

2.11 The blast load on the framing will be reduced in proportion to the amount of frangible wall and roof coverings removed by the blast. Therefore, when such coverings are used, as in mill buildings, the applicable design loadings listed in table 2, page 30 should be decreased by 25 percent. On the other hand, if the wall and roof coverings are of high strength and designed to remain in place, the blast loads on the framing will be severe. For such cases, the applicable design loading listed in table 2 should be increased by 50 percent.

DESIGN OF INTERIOR AND EXTERIOR WALLS

2.12 The various elements of the load-carrying system must be designed for the recommended loads with consideration being given to possible reversal of loading. Actually, exterior walls do not receive the full blast loading unless they are windowless. If they have windows, or even if they fail during loading, their loads will be transferred to the interior walls, so that the effect on the structural frame is not greatly changed unless *all* walls normal to the blast fail immediately. If so desired, exterior walls can be designed to carry the blast load. Interior partitions may need to be designed to remain in place. This will be necessary if the area behind a partition is to be used as a shelter. Although the interior wall loading is somewhat smaller than the exterior wall loading, it will act longer and should be assumed the same. A lateral design load of 150 psf should be assumed in designing interior and exterior walls, except those walls that are not intended to remain in place.⁶ Use allowable stresses specified for wind loads. The walls must be tied to the floors and roof so that separation does not occur.

HORIZONTAL-PLANE BRACING

2.13 Normally, a reinforced-concrete floor will be strong enough to resist bending in its plane. Two possible weaknesses in the floor system that must be avoided are buckling of the floor slab and failure of the floor at a construction joint. Buckling caused by horizontal loading from the outer wall along the edge of the slab can be prevented by stiffening the floor slab in this region. This can be accomplished by a rib-type floor with ribs running perpendicular to the outer wall. Construction joint failure is avoided by extending slab reinforcing steel through the joint a distance sufficient to develop its full strength. Floors must be tied into shear walls. (See fig. 9.) The roof system may require special attention. A reinforced-concrete roof slab supported on beams may solve the problem. A steel truss or diagonal bracing system in the horizontal plane at roof level will also serve. This truss or bracing system can be designed for 90-psf loads transferred from the exterior wall.

VERTICAL-PLANE BRACING

2.14 Shear panels or bents are the most critical elements of the structural system. They must be adequate to carry lateral and vertical blast loads transmitted by floors and roof, in addition to normal live and dead loads.

⁶ Structural elements such as panels, beams, or slabs, being small and light, will react more quickly to dynamic loads than will the structure as a whole. Consequently, for a loading such as shown in fig. 8, the equivalent static pressure on a beam or slab will be considerably greater than that on the structural frame which, reacting more slowly, is subjected to a smaller average pressure.

2.15 A number of structures in Hiroshima and Nagasaki designed for earthquake resistance, presumably for lateral loads of about one-tenth of the gravity load, showed good blast resistance. The most resistant of these structures were built with what amounted to shear walls as exterior walls. (See fig. 5.) These walls furnished a great deal of resistance in addition to that provided by the framing. For this reason, shear walls—exterior and/or interior—are strongly recommended for use whenever possible to supply resistance to lateral loads.

2.16 Shear walls can be of reinforced concrete, brick or other materials of adequate strength.⁷ The resistance of shear walls to lateral loads can be computed by multiplying the total horizontal cross-sectional area of the wall by the unit stress in shear allowed for wind.⁸

2.17 Normally, such a shear panel will fill the area between two columns and two floor slabs. There is no reason why the panels should not contain openings for doors and windows, providing the net horizontal cross section is used in calculating strength. If shear panels are used they should be used consistently throughout a structure, although it is reasonable to allow for the contribution of framing to the total resistance. If possible, panels in successive stories should be located so that there is a continuous line of panels from foundation to roof. However, framing can be used instead of panels in the upper stories if loading conditions permit. Shear panels need not be placed at all bents or between all columns in one bent, but they should be spaced not more than 100 feet apart in each story. They should be as symmetrically placed as possible in each structure. If an expansion joint is used in a floor, a shear panel should be placed on each side of the joint.

2.18 Lateral resistance also can be furnished by moment-resistant column-girder connections or by diagonal bracing in bents. (See fig. 10.) Since this kind of lateral strengthening is believed to be less satisfactory than shear walls, the latter are recommended for structures where practicable.

Relation Between Static Strength and Dynamic Behavior

2.19 Only when complete design procedures are available, and when all effects of an atomic bomb can be described quantitatively, can the architect or engineer know exactly the cost of installation or the increase in blast resistance resulting from the use of moment-resistant connections or shear walls. For blast-resistant multistory buildings,

⁷ Reinforced concrete is considered the best material for this purpose.

⁸ Shear panels so designed may be too thin for easy construction and must, therefore, be thickened accordingly.

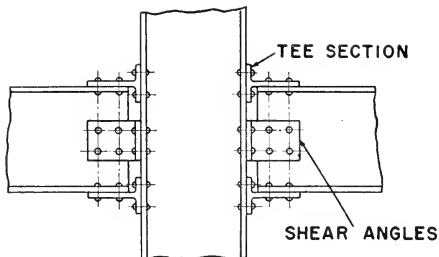

RIVETED MOMENT RESISTANT CONNECTION

NOTE:

Welded connection may be substituted for riveted type.

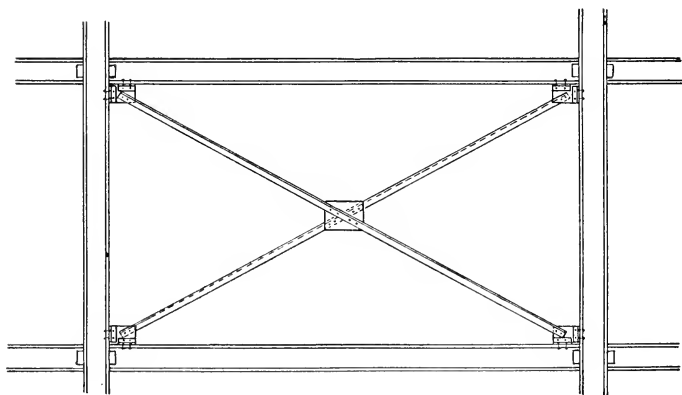

DIAGONAL WIND BRACING

FIGURE 10.—Methods of increasing lateral strength of a building.

the increase in general construction cost (without plumbing, heating, lighting, ventilating and approach work) should be about 3 percent, although it may vary according to the type of construction.⁹ How-

⁹ Two reinforced-concrete frame buildings were designed for conventional loads and for recommended blast loads. Building "A" is an 11-story building with floor plan dimensions of 158' x 190'. Building "B" is a 9-story structure of irregular floor plan with narrow wings. The increase in general construction cost for building "A" amounted to 2.2 percent, and for building "B" 3.8 percent.

ever, the cost will be much higher for strengthening industrial buildings that have permanent siding, because of their light weight and large area. Anything that can be done to give a structure consistent strength as suggested earlier in this chapter, and anything that can be done to increase its strength, particularly against lateral loads, will improve its ability to survive atomic blast.

2.20 An analysis has been made of a hypothetical structure under static and dynamic loads to show the magnitude of improvement that can be expected for various degrees of lateral strengthening. The structure considered is a two-story steel-framed building, two bents of which are shown in figure 11. The frame and floor systems of this building were designed to carry a 100-psf live load on the second floor and a roof load of 50 psf. Three conditions of static lateral strength were considered. Structure A has its girders pin-connected to columns which are continuous. The column-footing connections are capable of developing 50 percent of the moment capacity of the columns. This structure can carry a static lateral load of 20 psf on the front face of the building, without exceeding the allowable wind stress of 27,000 psi in the steel.

2.21 In addition to the lateral strength of structure A, structure B has column-girder connections capable of developing 50 percent of the moment capacity of the columns. Under these conditions of design, the building is capable of carrying a lateral load of 53 psf on its front face, without exceeding the allowable wind stress of 27,000 psi in the steel.

2.22 Structure C is identical to structures A and B except that the column-girder connections and column-footing connections are moment-resistant and capable of developing 100 percent of the moment capacity of the columns. This structure can withstand a lateral load of 106 psf on its front face, without exceeding the allowable wind stress of 27,000 psi in the steel.

2.23 The three buildings are assumed to be located at such distances from ground zero that each suffer the same permanent deflection. The distances from ground zero then give a measure of each building's resistance to this hypothetical blast and illustrate what gains can be made by increasing the lateral strength.

2.24 In this study the hypothetical structures are so placed that the dynamic load causes a permanent deflection of about 8½ inches at roof level.

2.25 With this criterion of equal deflections the following results were obtained:

(a) Structure C, the strongest, would be placed at about 6,200 feet, or at a pressure level of 4.7 psi (676 psf).

(b) Structure B, of medium strength, would be placed at about 7,200 feet, or at a pressure level of 3.4 psi (490 psf).

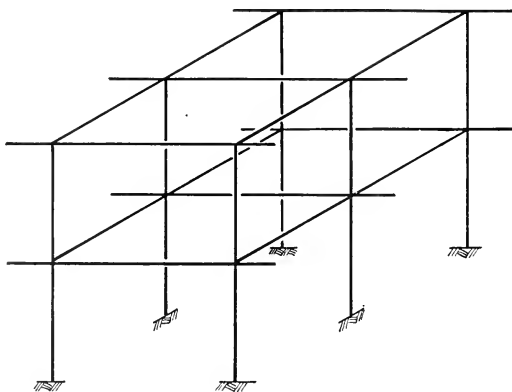
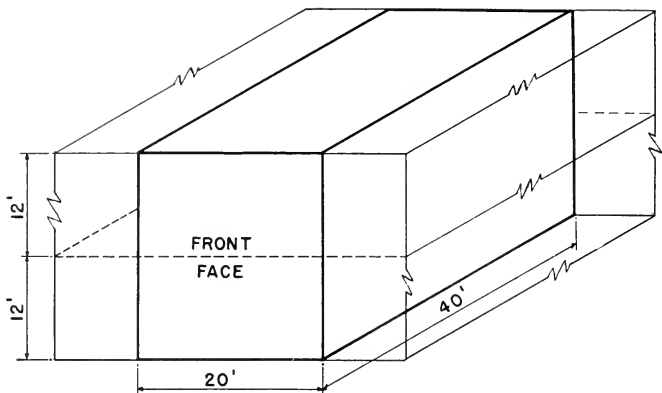

FRAME*

FIGURE 11.—Hypothetical structure (A, B, and C).

(c) Structure A, the weakest and perhaps the most conventional structure, would be placed at about 8,500 feet, or at a pressure level of 2.5 psi (360 psf). These results are summarized in table 1.

2.26 In considering the preceding analyses the following facts must be noted:

(a) A permanent deflection of about 4 inches per story in a framed structure is less than deflection at collapse.

(b) The actual strength of most buildings, because of the contribution of walls and partitions, is considerably greater than the calculated strength of the framing.

TABLE 1.—*Design static lateral strength and blast pressure levels for 8 $\frac{1}{2}$ -inch permanent deflection (20-KT bomb)*

Structure	Static lateral strength psf	Blast pressure level		Distance from ground zero (feet)
		psi	psf	
A.....	20	2.5	360	8,500
B.....	53	3.4	490	7,200
C.....	106	4.7	676	6,200

2.27 Equal or greater gains in dynamic strength can be made by other methods of increasing lateral resistance. Shear walls and diagonal wind bracing are the most effective common methods, but even interior partitions can be helpful if they are able to resist shear.

Influence of Shape and Size of Structure

2.28 Damage to structures depends not only on the type of structure but also to some extent on its shape and size. Stacks, for example, have a favorable shape and size and may survive a blast when surrounding buildings that are inherently stronger are levelled. This dependence on shape and size results from the effects of blast loading and from the strength of the structure.

BLAST LOADS

2.29 The greater the area of the face of the structure toward the blast, the greater are the forces that act on the structure as a whole. Further, the durations of these forces vary somewhat with the structure's dimensions. Consequently, the necessary strength of the bracing or shear panels resisting the blast loading will depend mainly on the area of the structure exposed to the blast and, to a less extent, on the structure's length measured in the direction of travel of the blast wave. In the present treatment this second effect will be neglected. Normally, of course, a structure must be designed to resist blast coming from any direction.

STRENGTH

2.30 Usually, the resistance or strength of a building will depend to some extent on its shape and on the orientation of the building with respect to the direction of blast. In a rectangular framed building the columns are generally oriented with their stronger axes

parallel to the long dimension of the building. Thus, for blast loads—other things being equal—the columns should be turned to provide greater resistance to blast on the long side.

ADVANTAGES OF SYMMETRY

2.31 Symmetry and simplicity in plan will make it easier to determine blast loads and resisting forces. If the structure is symmetrical, the lines of action of the loads and the resisting forces automatically will coincide. Unless they coincide, there is a tendency for the structure to rotate as well as to deflect. By this rotation, the bracing or shear walls on one side are deformed more than those on the other and tend to fail first. Under equal blast load and structural resistance of its components, an unsymmetrical building has a smaller overall resistance.

DIRECTION OF LOADING

2.32 Although the exact direction of the blast is impossible to predict, the most probable direction can often be logically assumed. For example, there may be only one probable target point in the vicinity of the structure. However, if the aiming point is within one-half mile, all directions should be considered as equally probable because of possible bomb aiming errors. If the potential aiming point is at a distance greater than one-half mile, primary loading should be expected to occur on the side toward the predicted target. Orienting the structure with the smaller projection facing the probable target point may be desirable.

The Effect of Internal Pressure

2.33 Except in the case of a blast-resistant windowless building, any blast wave that reaches a building will penetrate to its interior through openings, such as windows and doors and collapsed curtain walls. The resulting pressure is not necessarily of extreme danger to people. Human beings can endure pressures of about 35 psi for short periods without severe injury. The blast wind which is strong enough to throw people around and create and propel missiles, is somewhat more hazardous. Of greater importance structurally, however, is the effect of the resulting internal pressure on the building.

EFFECT ON PARTITIONS AND FLOORS

2.34 Generally, the pressure that develops inside a building is not much less than the pressure that is applied to the front wall. (See fig. 12.) This internal pressure is capable of breaking down doors, interior partitions, and exterior walls, turning them into dangerous missiles. For this reason, a lightweight partition exposed directly to blast from the outside is not sufficient protection for personnel.

2.35 Since the internal pressure must escape through existing openings or through others that it makes, it often acts for a longer period. This, combined with the fact that the internal pressure is apt to be considerably larger than the external pressure, except on the front wall, explains why the walls of buildings frequently blow outward. The internal pressure also acts on floor slabs and partitions. If the pressures in two adjacent stories are equal, the forces acting on the intervening floor slab are equal and in balance. If, however, the pressure enters one story but not the next, the unbalanced pressure may cause the floor to fail. Where space beneath the ground floor does not contain openings or breakable panels amounting to at least 20 percent of the lower story wall area, the ground floor should be designed for a live downward load of 100 psf. Similar unbalanced forces act on any partition that separates a vented from an unvented region. Allowance must be made for this effect. Avoiding the use of unvented regions as much as possible is the simplest solution. Recommended design live loads are given in table 2. Details of design should be investigated for reversal of loading.

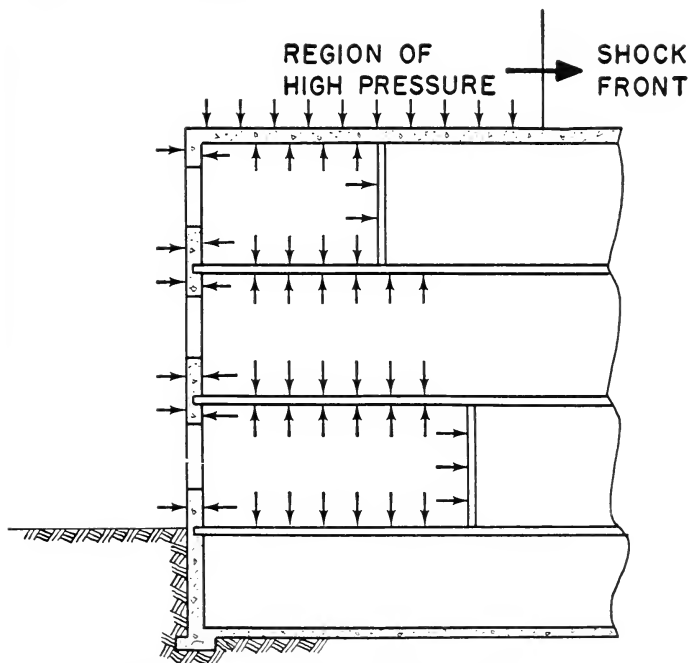

FIGURE 12.— Pressure on exterior and interior walls and slabs.

2.36 In buildings designed with completely enclosed horizontal and vertical pipe galleries and shafts, the use of breakable panels or openings at reasonable intervals—about 25 feet apart and amounting to 20 percent of the area—will permit venting and in general will tend to avoid damage.

ELEVATOR SHAFTS AND STAIRWELLS

2.37 Elevator shafts and stairwells present other problems, especially since shelter areas may be adjacent to them. Frequently, elevator shafts extend beyond the roof to a penthouse, and therefore may admit blast pressure and be subjected to large internal forces. If the region just outside the shaft is somewhat shielded from pressure (as may happen at some distance from the outside walls in a large building) the walls of the shaft can be blown outward. To avoid damage to shaft walls and danger to persons sheltered near them, the walls should be designed to withstand a pressure of 150 psf from either side. In addition, a resistant cover may be provided to reduce pressures within the shaft and thus prevent damage to elevators. (See fig. 13.) The cover may consist of a reinforced-concrete slab at the top of the shaft with holes for the various cables. Absolute air-tightness is not required. A design load of 150 psf is recommended for elevator shaft covers.

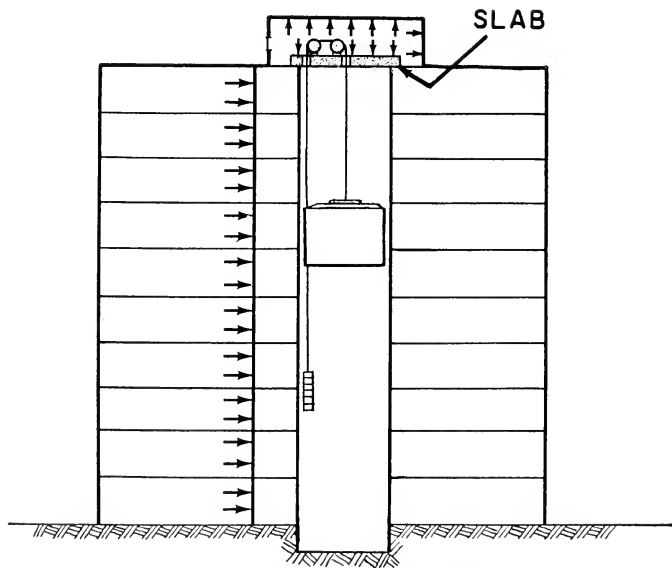

FIGURE 13.—Elevator shaft protection.

GENERAL CONSIDERATIONS

2.38 In general, venting is more easily permitted than prevented. Venting of adjacent spaces in a building results in more or less equilibrium of the forces on the intervening panels or slabs. Perfect venting of all parts of a building is seldom possible although it can be approached. For example, a building with a fairly strong frame and very light breakable panels that form the outer walls, partitions, and roof will be difficult to damage seriously. Blast will strip the panels from the frame but will exert relatively small forces on the frame itself. If venting is not possible, or will be incomplete, it is necessary either to design members and panels to withstand large pressure loads or to expect damage. Damage to partitions is frequently not serious and can be accepted. Damage to floor slabs is serious enough to require attention.

2.39 Panels that can be loaded by blast should be either very weak or very strong. Weak panels encourage venting, break without exerting large forces on the rest of the structure and generally produce less dangerous fragments at failure than do heavier walls. A wall strong enough to remain in place produces no fragments; may not require replacement; and is strong enough to strengthen the structure, especially when acting as a shear wall. On the other hand, a heavy but weak wall, such as masonry, transmits large forces to the rest of the structure before it fails and produces dangerous missiles when it does fail. Therefore, preferred materials for walls and panels are either lightweight, relatively frangible sheets such as gypsum and asbestos, or reinforced concrete that is well tied to the rest of the structure.

2.40 The best kind of wall or partition to use will depend mainly on the function of the structure and on its type. If the contents need no special protection from blast or from the elements, the use of lightweight, breakable walls and partitions which can be replaced easily and cheaply may be more economical. In this case the frame of the building need only be strong enough to withstand the breaking force of the panels and the forces of blast and wind. However, if the contents need protection, the walls should be designed to remain in place. The rest of the structure—floors, transverse walls, and frame—must be capable of resisting the loads that will be applied. Blast-resistant walls, while they have the disadvantage of increasing the loading on the frame, have the advantage of serving as shear walls to resist blast loads from other directions.

MINIMIZING HAZARDS

Utilities

3.1 In new construction, potential shelter areas should be kept free from hazards if feasible. Many basement corridors or passageways would afford a high degree of protection with minimum hazard if overhead steam, water, and gas pipes were protectively housed. A still higher degree of protection can be obtained if pipes are located away from shelter areas and away from areas where they are likely to be damaged, such as exterior walls above ground.

3.2 For existing buildings, one safety measure is the installation of valves, so that in event of attack, pipes and containers can be made safe and pressures removed. In certain cases this may not be practicable because of installation cost and excessive periods of shutoff. An alternative is the installation of valves that are normally left open but which can be closed by a warden or other official if there is a break. Another possibility is the construction of partitions separating the shelter area from the utilities. None of these measures is entirely effective. However, the danger is not believed to be serious enough to warrant such strong measures as relocating the utilities or forbidding the use of an otherwise suitable area for shelter.

Ceiling Fixtures and Other Missiles

3.3 Ceiling fixtures, hung ceilings, and poorly supported partitions and other structural elements may be loosened and thrown about by blast. The same is true of certain exterior attachments, such as parapets and ornamental brick or stonework. Effort should be made to minimize, eliminate, or otherwise avoid all such hazards, particularly in or near shelter areas.

Fire

3.4 Following an atomic attack, fires started by short-circuited electric wires and overturned stoves and heaters can result in a severe conflagration or even a fire storm. Generally, conditions for a fire storm depend on a city's characteristics and on the number of fires compared to the number of effective fire fighters. A dangerous condition exists when the building density of an area is more than 20 percent.¹⁰ The presence of processing or storage areas containing

¹⁰ Building density is the ratio of total ground area of buildings to total area.

large quantities of highly combustible or explosive materials is also dangerous. Although an ordinary automobile service station does not fall in this category, an oil storage depot does.

3.5 Outside of removing enough structures to form firebreaks, little can be done to reduce the hazard of a highly susceptible area. Generally, important new construction should not be undertaken in such areas.

Radiation

3.6 In an atomic attack nuclear radiation is a serious danger. Protection against it is furnished only by distance or material interposed between the source and the person. Thermal radiation also is dangerous. The carrying power of thermal radiation is greater than that of nuclear radiation, and severe burns to exposed persons are possible at distances up to 2 miles from the burst. Protection against thermal radiation can be furnished by almost any material, except clear glass. Nuclear radiation, however, can be stopped only by relatively large amounts of material. The protection furnished depends mainly on the weight of the material. A hundred pounds of concrete gives about the same protection as a hundred pounds of lead distributed over an equal area. The most economical materials to use for protection of persons are earth and concrete. Figure 2 shows the slant thickness of earth or concrete required for different degrees of protection against radiation from a 20-KT bomb explosion. A reasonable degree of protection is given by 18 inches of concrete or by 30 inches of earth, $\frac{1}{2}$ mile from ground zero.

3.7 A potential shelter area above ground level in a building should be in the interior of the building, partly to lessen the danger from flying debris and partly for protection against radiation. Tall neighboring buildings will afford additional protection. Shelter areas in basements at least 80 percent below ground level have fairly good radiation protection. Since overhead as well as side lateral protection is needed, the total thickness of floors and walls through which the radiation must pass to enter the shelter area is important.

Glass

3.8 In the area surrounding ground zero—possibly up to 200 square miles—window glass will be broken and projected at high velocities causing many serious casualties. Various measures can be taken to reduce the damage caused by flying glass. Heavy fireproofed cloth curtains securely fastened over windows at both top and bottom will catch some fragments. Hardware cloth of one-fourth inch mesh will stop larger fragments.

Exits

3.9 Since evacuation of shelters may be necessary immediately after attack, adequate exits must be provided. The designer must consider the possibility that exits, particularly in wall-bearing buildings, will be blocked by debris. If a part of a building is demolished, passage through that part to an exit may be impossible. Therefore, every building with shelter areas should have adequate exits on at least two sides. Strengthening the building frame near the exit also may be advisable.

DESIGN OF PROTECTED AREAS IN BUILDINGS

Location

4.1 Generally, the best protection is in the interior of a building below the three highest stories. If the area is intended as a shelter for persons, both radiation shielding and blast protection are necessary. For radiation shielding, the total thickness of walls and total thickness of floor and roof slabs should be equivalent to about 18 inches of concrete. Adjacent tall buildings may contribute to this total. For blast, the shelter floor, roof, and walls must be strong enough to resist pressure and debris loads. Only blast and debris protection are needed for equipment or records and can be provided near exterior walls or on top stories.¹¹

Blast and Debris Walls, and Horizontal Slabs

4.2 Reinforced-concrete walls give the best protection. They must completely enclose the area to be protected although they need not be continuous. Adequate openings for entrance and exit must be provided. There is considerable advantage in leaving enough openings so that pressure equalization is quickly achieved on both sides of every wall. This equalization can be accelerated by leaving openings in the upper parts of the walls, provided there is no danger of missiles being driven through the openings. There should be at least two entrance-exit openings for each area and more than two if the areas shelter more than 50 persons. These openings must be arranged to minimize the danger of debris entering the shelter area. One of the simplest ways of doing this is to place a baffle in line with the doorway as shown in figure 14. A similar arrangement with the baffle outside is equally effective. No doors should be used on openings unless provision is made to keep them open during attacks.

4.3 Blast walls must be designed to stay in place. This requires that they either be keyed to the floors below and above or supported by the columns of the building. In new construction the former method is recommended although both are possible.¹²

4.4 The actual process of designing a wall or slab for a particular dynamic loading condition is beyond the scope of this manual since it involves a prediction of the intensity and duration of the forces:

¹¹ *Shelter from Atomic Attack in Existing Buildings, Part I—Methods for Determining Shelter Needs and Shelter Areas, TM-5-1 and Part II—Improvement of Shelter Areas, TM-5-2.* FCDA.

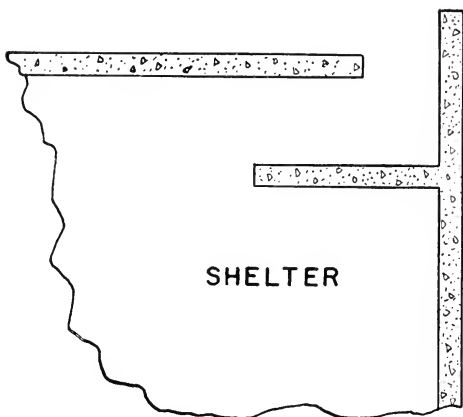

FIGURE 14.—Baffle for shelter area.

the behavior of the loaded member while deforming beyond the elastic limit; and the dynamic response of the loaded member to the predicted forces. However, as an interim procedure, blast walls and horizontal slabs of 8-inch thick concrete, reinforced with a minimum of $\frac{5}{8}$ -inch rounds at 6 inches o. c., or equivalent area, in each face are recommended. This is the minimum requirement for normal story heights. If possible, walls should be continuous with the floor slabs above and below, and reinforcing bars should be well anchored to adjoining members. Alternately, the walls may span horizontally between columns. A doubly reinforced slab with reinforcing extending in both directions in each face could be used. However, it is simpler to have the wall reinforced to span one way.

4.5 Tying blast walls to horizontal slabs above and below stiffens and strengthens the stories in which they are placed and may eliminate entirely the need for any additional shear resistance at those levels. In short, they function as shear walls.

The Protective Core

4.6 If blast walls are placed at corresponding locations in all stories of a building, the result essentially is a structure within a

¹² In existing buildings it will be difficult to pour concrete very close to a ceiling and extremely difficult to connect the wall to the floor slab above. A possible alternative is to use walls about 7 or 8 feet high which must then span horizontally between columns. Although such a wall is weaker than one with supports at top and bottom it is easier to construct and has the advantage of almost immediate pressure equalization.

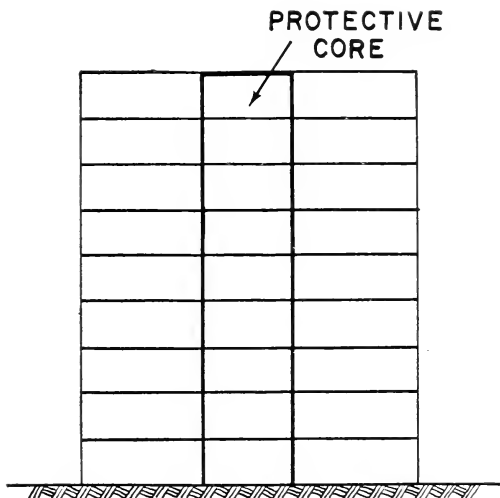

FIGURE 15.—Protective core in a building.

structure which may be called the protective core. (See fig. 15.) This core can be designed for two primary functions:

(a) Defining relatively safe areas that can be used for shelter or vital storage.

(b) Furnishing shear resistance to the building as a whole. The design of various elements of the core follows steps already outlined. Individual panels should be at least 8 inches thick reinforced to withstand blast loading from either direction. Blast forces on the structure as a whole are replaced by a set of equivalent static loads which produce shears in all stories.

4.7 In addition, the core must provide sufficient radiation protection and be designed for easy and rapid access, with provision for excluding debris. Stairs should be placed in the core and means arranged for leaving the building directly from the core, particularly if fire is a special hazard.

Conclusions

4.8 In most cases resistance of buildings to blast loads can be improved by various simple and relatively inexpensive measures. The principal goal is to give reasonably consistent strength to the various elements of a structure and to the structure as a whole. Table 2 shows tentatively recommended design live loads for all conventional building types. Structures designed to provide adequate

resistance for these loads are expected to have a reasonable chance of survival at distances more than one-half mile from a 20-KT atomic bomb. If the resistance is provided by shear walls, damage will be greatly reduced. The complete design of the structure must be based on a combination of blast load and dead load, as well as upon the other combinations of loading specified by the applicable building code. For the blast plus dead load combination, use allowable stresses specified for wind.

4.9 Slight deviations from the design loads recommended in table 2 may be desirable for reasons of economy or geographical location.

TABLE 2.—*Recommended design live loads for blast*

Structural members	Equivalent static load
Structure as a whole (framing, vertical and horizontal bracing, footings, etc.).	90 psf on vertical surfaces; 70 psf downward on roof.
Roof and ground floor (slabs and beams). (See pars. 2.34–2.35.)	100 psf vertically downward; 70 psf upward.
Other floors (except shelter area)-----	70 psf from either side.
Walls—interior and exterior (except exterior of shelter areas and those walls expected to fail).	150 psf from either side.
Slab covering stairwell or elevator shaft-----	150 psf down.

4.10. In general, continuity should be supplied where possible, particularly in principal members. Walls and partitions should be either strong enough to have a good chance of survival or weak enough to fail without endangering the rest of the structure or its contents. Loosely attached fixtures, suspended ceilings and all other possible sources of flying debris are undesirable in general, and should be excluded.

OFFICIAL CIVIL DEFENSE PUBLICATIONS

The following Federal Civil Defense Administration publications are on sale by the Superintendent of Documents, Washington 25, D. C. (Order blanks are supplied for your convenience at the back of this book.)

1. *United States Civil Defense*, 1950, 25 cents, 168 pp. The national plan for organizing the civil defense of the United States.

Administrative Guides

1. *Civil Defense in Industry and Institutions*, Pub. AG-16-1, 1951, 25 cents, 64 pp. Plans for organizing and administering civil defense self-protection programs for the Nation's industrial plants, office and apartment buildings, and other institutions.
2. *The Clergy in Civil Defense*, Pub. AG-25-1, 1951, 10 cents, 12 pp. Guide for the clergy of all faiths for determining their place and function in civil defense.
3. *Emergency Welfare Services*, Pub. AG-12-1, 1952, 20 cents, 62 pp. Guide for developing a program to meet the multiple welfare problems that would arise from enemy attack.
4. *Engineering Services*, Pub. AG-13-1, 1952, 15 cents, 25 pp. Assists State and local civil defense directors in planning and establishing their engineering services.
5. *Fire Services*, Pub. AG-9-1, 1951, 15 cents, 27 pp. Basic guide to assist States and communities in planning, organizing, staffing, and operating an expanded fire-fighting service during periods of war emergency.
6. *Health Services and Special Weapons Defense*, Pub. AG-11-1, 1950, 60 cents, 264 pp. Methods for organization of all basic health and special weapons defense (atomic, biological, and chemical warfare) for State and local civil defense programs.
7. *Police Services*, Pub. AG-10-1, 1951, 20 cents, 48 pp. Basic guide for State and local civil defense officials in organizing and directing police civil defense services.
8. *Principles of Civil Defense Operations*, Pub. AG-8-1, 1951, 20 cents, 48 pp. Basic guide in planning and organizing for mutual aid and mobile support operations.
9. *The Rescue Service*, Pub. AG-14-1, 1951, 15 cents, 32 pp. Basic guide for State and local civil defense officials in organizing rescue services and training rescue teams.

10. *The Supply Service*, AG-6-1, 20 cents, 50 pp. Assists State and local civil defense directors and supply officials in establishing adequate supply programs.
11. *The Warden Service*, Pub. AG-7-1, 1951, 20 cents, 48 pp. Basic guide for civil defense directors and supervisory wardens in selecting, organizing, training, and equipping the warden service.

Public Booklets

1. *Duck and Cover*, Pub. PA-6, 1951, 5 cents, 14 pp. Cartoon instruction for children on what to do in case of atomic attack.
2. *Emergency Action to Save Lives*, Pub. PA-5, 1951, 5 cents, 32 pp. Practical instructions for the untrained person on the emergency care of injured people.
3. *Fire Fighting for Householders*, Pub. PA-4, 1951, 5 cents, 32 pp. Basic information for the householder on how fires start, how they can be prevented, and how to fight fires.
4. *This Is Civil Defense*, Pub. PA-3, 1951, 10 cents, 32 pp. Highlights of the national civil defense program and the part the volunteer must play to make civil defense a success.
5. *What You Should Know About Biological Warfare*, Pub. PA-2, 1951, 10 cents, 32 pp. Techniques of personal survival under biological warfare attacks.
6. *Survival Under Atomic Attack*, 1950, 10 cents, 32 pp. Techniques of personal survival under atomic bomb attacks.

Technical Manuals

1. *Blood and Blood Derivatives Program*, Pub. TM-11-5, 1952, 40 cents, 179 pp. Describes Federal, State, and local organization and operation of a civil defense blood program.
2. *Civil Defense in Schools*, Pub. TM-16-1, 1952, 15 cents, 32 pp. A guide and reference for local and State superintendents of schools in organizing and operating programs for the self-protection of schools, their physical facilities, staff, and students.
3. *Organization and Operation of Civil Defense Casualty Services*, Part III—*Medical Records for Casualties*, Pub. TM-11-3, 1952, 15 cents, 31 pp. Recommends medical records and forms for uniform use by all States in the handling of casualties resulting from enemy attack.
4. *Outdoor Warning Device Systems*, Pub. TM-4-1, 1951, 15 cents, 36 pp. Data for planning, procuring, and installing public warning device systems for civil defense.

5. *Radiological Decontamination in Civil Defense*. Pub. TM-11-6, 1952, 15 cents, 31 pp. Provides information for all radiological defense personnel and serves as an operations manual for decontamination crews.
6. *Shelter from Atomic Attack in Existing Buildings*, Part I—*Method for Determining Shelter Needs and Shelter Areas*, Pub. TM-5-1, 1952, 20 cents, 53 pp. Instructions, forms, and recommendations for use of civil defense directors, survey teams and their supervisors, and technically qualified personnel in conducting a shelter survey.
7. *Shelter from Atomic Attack in Existing Buildings*, Part II—*Improvement of Shelter Areas*, Pub. TM-5-2, 1952, 15 cents, 26 pp. Offers suggestions to architects and engineers for improving certain shelter areas.
8. *The Nurse in Civil Defense*, Pub. TM-11-7, 1952, 20 cents, 52 pp. Assists key civil defense nurses in planning and operating State and local nursing services.
9. *Water Supplies for Wartime Fire Fighting*, Pub. TM-9-1, 1951, 10 cents, 16 pp. Program for increasing available water supplies to meet the needs of emergency water-supply operations during wartime.

Other Publications

1. *Annotated Civil Defense Bibliography for Teachers*, Pub. TEB-3-2, 1951, 20 cents, 28 pp. Aid for teachers in locating publications for use in civil defense planning and instruction in schools.
2. *Civil Defense Against Atomic Warfare*, 1950, 10 cents, 24 pp. Lists sources of unclassified scientific and technical data useful as background information in planning civil defense against atomic bombing.
3. *Civil Defense and National Organizations*, 10 cents, 15 pages. Outlines the need for civil defense and informs national organizations how they can participate in the program.
4. *Civil Defense in Outline*, 1951, 35 cents, 41 pp. Guide for the use of organizations in their national and State civil defense programs.
5. *Civil Defense Nursing Needs*, Pub. VM-1, 1952, 15 cents, 17 pp. Outlines program for increasing nursing services to ensure an adequate supply of nurse power in the event of attack or disaster.
6. *Damage from Atomic Explosions and Design of Protective Structures*, 1950, 15 cents, 32 pp. Describes damage from blast to various types of structures and buildings, and suggests design of building construction to resist these effects.

7. *Fire Effects of Bombing Attacks*, Doc. 132, 1950, 15 cents, 48 pp. Summarizes data on World War II bombing attacks and suggests a method of appraising fire susceptibility of cities to minimize the effects of mass fires.
8. *Interim Civil Defense Instructions for Schools and Colleges*, Pub. TEB-3-1, 1951, 30 cents, 32 pp. Guide for educational administrators in planning immediate civil defense training and education programs.
9. *Medical Aspects of Atomic Weapons*, 1950, 10 cents, 24 pp. Medical and biological aspects of injuries resulting from atomic bomb explosions and their treatment.
10. *The Warden's Handbook*, Pub. H-7-1, 1951, 15 cents, 34 pp. Basic reference aid for the block warden.
11. *The Staff College*, Brochure, 1952, 10 cents, 15 pp. Describes courses, registration procedures, and nature of facilities of FCDA Staff College at Olney, Maryland.
12. *Annual Report for 1951*, 1952, 30 cents, 108 pp. Comprehensive report to the President and Congress on the FCDA program during 1951.
13. *National Civil Defense Conference Report*, May 1951, 45 cents, 73 pp. Transcript of the National Civil Defense Conference, held in Washington, D. C., on May 7 and 8, 1951.
14. *Civil Defense Household First Aid Kit*, Leaflet, 1951, \$1.50 per 100 copies. Lists first-aid items for a family of four or less; gives items to be stocked, quantity, substitutes, and uses.
15. *Atomic Blast Creates Fire*, Leaflet, 1951, \$1.50 per 100 copies. Instruction to householders on how to reduce fire hazards and prevent fires in the home.
16. *Air-Raid Alert Card*, \$1.50 per 100 copies. Instruction card on what to do in case of an atomic bomb attack.



PANEL MEMBERS

GEORGE H. FIELD, *Building Contractor.*

HARRY L. BOWMAN, *Atomic Energy Commission.*

LEO H. CORNING, *Portland Cement Association.*

ROBERT CORSBIE, *Atomic Energy Commission.*

JOHN W. DUNHAM, *Public Buildings Administration.*

ERIC L. ERICKSON, *Bureau of Public Roads.*

FRED R. FLETMEYER, *Associated General Contractors.*

JEWELL M. GARRELTS, *American Society of Civil Engineers.*

RICHARD S. GREEN, *Public Health Service.*

JOHN D. GRIFFITHS, *American Institute of Steel Construction.*

DOUGLAS E. PARSONS, *American Concrete Institute.*

FREDERIC A. PAWLEY, *American Institute of Architects.*

SHERWOOD B. SMITH, *Department of Defense.*

CDR. G. L. WALLING, *Bureau of Yards and Docks, United States Navy.*

