



This is a digital copy of a book that was preserved for generations on library shelves before it was carefully scanned by Google as part of a project to make the world's books discoverable online.

It has survived long enough for the copyright to expire and the book to enter the public domain. A public domain book is one that was never subject to copyright or whose legal copyright term has expired. Whether a book is in the public domain may vary country to country. Public domain books are our gateways to the past, representing a wealth of history, culture and knowledge that's often difficult to discover.

Marks, notations and other marginalia present in the original volume will appear in this file - a reminder of this book's long journey from the publisher to a library and finally to you.

### **Usage guidelines**

Google is proud to partner with libraries to digitize public domain materials and make them widely accessible. Public domain books belong to the public and we are merely their custodians. Nevertheless, this work is expensive, so in order to keep providing this resource, we have taken steps to prevent abuse by commercial parties, including placing technical restrictions on automated querying.

We also ask that you:

- + *Make non-commercial use of the files* We designed Google Book Search for use by individuals, and we request that you use these files for personal, non-commercial purposes.
- + *Refrain from automated querying* Do not send automated queries of any sort to Google's system: If you are conducting research on machine translation, optical character recognition or other areas where access to a large amount of text is helpful, please contact us. We encourage the use of public domain materials for these purposes and may be able to help.
- + *Maintain attribution* The Google "watermark" you see on each file is essential for informing people about this project and helping them find additional materials through Google Book Search. Please do not remove it.
- + *Keep it legal* Whatever your use, remember that you are responsible for ensuring that what you are doing is legal. Do not assume that just because we believe a book is in the public domain for users in the United States, that the work is also in the public domain for users in other countries. Whether a book is still in copyright varies from country to country, and we can't offer guidance on whether any specific use of any specific book is allowed. Please do not assume that a book's appearance in Google Book Search means it can be used in any manner anywhere in the world. Copyright infringement liability can be quite severe.

### **About Google Book Search**

Google's mission is to organize the world's information and to make it universally accessible and useful. Google Book Search helps readers discover the world's books while helping authors and publishers reach new audiences. You can search through the full text of this book on the web at <http://books.google.com/>

NYPL RESEARCH LIBRARIES



3 3433 06633665 6



3-VBA

Intern













# INTERNATIONAL LIBRARY OF TECHNOLOGY

A SERIES OF TEXTBOOKS FOR PERSONS ENGAGED IN THE ENGINEERING  
PROFESSIONS AND TRADES OR FOR THOSE WHO DESIRE  
INFORMATION CONCERNING THEM. FULLY ILLUSTRATED  
AND CONTAINING NUMEROUS PRACTICAL  
EXAMPLES AND THEIR SOLUTIONS

PLANT ANALYSIS  
DISTEMPER COLOR  
BOOKCOVER DESIGNING  
CARPET DESIGNING  
OILCLOTH AND LINOLEUM DESIGNING  
WALLPAPER DESIGNING  
THE AMERICAN VIGNOLA  
COLOR HARMONY

NEW YORK  
98665X PUBLIC  
LIBRARY

SCRANTON:  
INTERNATIONAL TEXTBOOK COMPANY

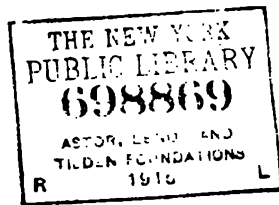

Copyright, 1901, 1905, by INTERNATIONAL TEXTBOOK COMPANY.

Entered at Stationers' Hall, London.

**Plant Analysis:** Copyright, 1905, by INTERNATIONAL TEXTBOOK COMPANY. Entered at Stationers' Hall, London.

**Distemper Color:** Copyright, 1905, by INTERNATIONAL TEXTBOOK COMPANY. Entered at Stationers' Hall, London.

**Bookcover Designing:** Copyright, 1905, by INTERNATIONAL TEXTBOOK COMPANY. Entered at Stationers' Hall, London.

**Carpet Designing:** Copyright, 1905, by INTERNATIONAL TEXTBOOK COMPANY. Entered at Stationers' Hall, London.

**Oilcloth and Linoleum Designing:** Copyright, 1905, by INTERNATIONAL TEXTBOOK COMPANY. Entered at Stationers' Hall, London.

**Wallpaper Designing:** Copyright, 1905, by INTERNATIONAL TEXTBOOK COMPANY. Entered at Stationers' Hall, London.

**The American Vignola:** Copyright, 1902, by Wm. R. Ware. Copyright, 1904, by INTERNATIONAL TEXTBOOK COMPANY.

**Color Harmony:** Copyright, 1901, by INTERNATIONAL TEXTBOOK COMPANY. Entered at Stationers' Hall, London.

All rights reserved.

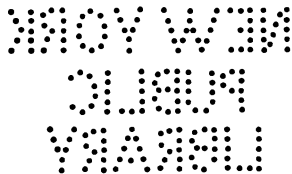

PRINTED IN THE UNITED STATES.



23073

## PREFACE

---

The International Library of Technology is the outgrowth of a large and increasing demand that has arisen for the Reference Libraries of the International Correspondence Schools on the part of those who are not students of the Schools. As the volumes composing this Library are all printed from the same plates used in printing the Reference Libraries above mentioned, a few words are necessary regarding the scope and purpose of the instruction imparted to the students of—and the class of students taught by—these Schools, in order to afford a clear understanding of their salient and unique features.

The only requirement for admission to any of the courses offered by the International Correspondence Schools, is that the applicant shall be able to read the English language and to write it sufficiently well to make his written answers to the questions asked him intelligible. Each course is complete in itself, and no textbooks are required other than those prepared by the Schools for the particular course selected. The students themselves are from every class, trade, and profession and from every country; they are, almost without exception, busily engaged in some vocation, and can spare but little time for study, and that, usually outside of their regular working hours. The information desired is such as can be immediately applied in practice, so that the student may be enabled to exchange his present vocation for a more congenial one, or to rise to a higher level in the one he now pursues. Furthermore, he wishes to obtain a good working knowledge of the subjects treated in the shortest time and in the most direct manner possible.

In meeting these requirements, we have produced a set of books that in many respects, and particularly in the general plan followed, are absolutely unique. In the majority of subjects treated the knowledge of mathematics required is limited to the simplest principles of arithmetic and mensuration, and in no case is any greater knowledge of mathematics needed than the simplest elementary principles of algebra, geometry, and trigonometry, with a thorough, practical acquaintance with the use of the logarithmic table. To effect this result, derivations of rules and formulas are omitted, but thorough and complete instructions are given regarding how, when, and under what circumstances any particular rule, formula, or process should be applied; and whenever possible one or more examples, such as would be likely to arise in actual practice—together with their solutions—are given to illustrate and explain its application.

In preparing these textbooks, it has been our constant endeavor to view the matter from the student's standpoint, and to try and anticipate everything that would cause him trouble. The utmost pains have been taken to avoid and correct any and all ambiguous expressions—both those due to faulty rhetoric and those due to insufficiency of statement or explanation. As the best way to make a statement, explanation, or description clear is to give a picture or a diagram in connection with it, illustrations have been used almost without limit. The illustrations have in all cases been adapted to the requirements of the text, and projections and sections or outline, partially shaded, or full-shaded perspectives have been used, according to which will best produce the desired results. Half-tones have been used rather sparingly, except in those cases where the general effect is desired rather than the actual details.

It is obvious that books prepared along the lines mentioned must not only be clear and concise beyond anything heretofore attempted, but they must also possess unequalled value for reference purposes. They not only give the maximum of information in a minimum space, but this information is so ingeniously arranged and correlated, and the

**indexes** are so full and complete, that it can at once be made available to the reader. The numerous examples and **explanatory** remarks, together with the absence of long **demonstrations** and abstruse mathematical calculations, are of great assistance in helping one to select the proper **formula**, method, or process and in teaching him how and when it should be used.

Four of the volumes composing this library are devoted to the subject of architectural and decorative design. This volume treats specifically of design as applied to definite purposes and the use and treatment of special mediums required to execute designs for the several purposes set forth. Considerable attention is given to the Analysis of Plant Forms in order to reduce them to a conventionalized representation that can be reproduced with propriety, either by weaving or printing. Opaque water color, transparent water color, and other mediums are considered, as each is best adapted to the purpose required, and the technical details in the manufacture of bookcovers, carpets, wall-paper, etc., that are likely to govern or influence the designer, are fully set forth. In *The American Vignola* are treated the proportions of classic details according to Vignola, but based on a new and simplified arrangement which adopts them readily to modern measurement. In *Color Harmony* is treated the theory of coloring as applied to art and architecture.

The method of numbering the pages, cuts, articles, etc. is such that each subject or part, when the subject is divided into two or more parts, is complete in itself; hence, in order to make the index intelligible, it was necessary to give each subject or part a number. This number is placed at the top of each page, on the headline, opposite the page number; and to distinguish it from the page number it is preceded by the printer's section mark (§). Consequently, a **reference** such as § 16, page 26, will be readily found by looking along the inside edges of the headlines until § 16 is found, and then through § 16 until page 26 is found.

INTERNATIONAL TEXTBOOK COMPANY.



## CONTENTS

---

	<i>Section</i>	<i>Page</i>
<b>PLANT ANALYSIS</b>		
Introduction . . . . .	5	1
Conventionalism . . . . .	5	2
Nature Study . . . . .	5	13
Outlining and Rendering . . . . .	5	15
Decorative Treatment . . . . .	5	22
Conventionalization . . . . .	5	27
<b>DISTEMPER COLOR</b>		
Classes of Color . . . . .	6	1
Color Matching . . . . .	6	9
Color Harmony . . . . .	6	13
Classification . . . . .	6	14
Spectrum Scales . . . . .	6	14
Difference Between Mixing Colored Lights and Colored Pigments . . . . .	6	18
Classification of Color Harmonies . . . . .	6	22
Color Schemes From Nature . . . . .	6	29
<b>BOOKCOVER DESIGNING</b>		
Bookbinding . . . . .	7	1
Early Stages of the Art . . . . .	7	1
Tools . . . . .	7	3
Early Influences and Styles . . . . .	7	5
Modern Bookbinding . . . . .	7	22
Making the Bookcover Cartoons . . . . .	7	31
Classes of Bookcovers . . . . .	7	32
Tooled Bookcovers . . . . .	7	32
Printed Bookcovers . . . . .	7	35



<i>BOOKCOVER DESIGNING—Continued</i>	<i>Section</i>	<i>Page</i>
Preparing the Drawings . . . . .	7	38
Designs for Zinc Etchings . . . . .	7	41
Paper Covers . . . . .	7	42
Requisites in Doing Successful Bookcover Designing . . . . .	7	46
Book Plates . . . . .	7	47
Style of Rendering . . . . .	7	56
Lettering . . . . .	7	56
<b>CARPET DESIGNING</b>		
Brussels and Wilton Carpets . . . . .	8	1
Designing . . . . .	8	5
Oriental Rugs . . . . .	8	19
<b>OILCLOTH AND LINOLEUM DESIGNING</b>		
Printing Oilcloths . . . . .	9	1
The Printing Process . . . . .	9	3
The Designs . . . . .	9	6
<b>WALLPAPER DESIGNING</b>		
Manufacture of Wallpaper . . . . .	10	1
Preparing the Design . . . . .	10	12
Principles of Wall Decoration . . . . .	10	22
<b>THE AMERICAN VIGNOLA</b>		
The Five Orders . . . . .	11	9
Introduction . . . . .	11	9
Mouldings, Plate I . . . . .	11	13
The Orders . . . . .	11	17
Vignola's Orders, Plate II . . . . .	11	27
The Tuscan Order, Plates III and IV . . . . .	11	29
Table of the Tuscan Order, Plates V, VI, and VII . . . . .	11	30
The Doric Order, Plates VII, VIII, IX, and X . . . . .	11	30
Table of the Doric Order, Plates VII, VIII, IX, and X . . . . .	11	38
The Ionic Order, Plates VIII and IX . . . . .	11	39

CONTENTS

v

<b>THE AMERICAN VIGNOLA—Continued</b>	<i>Section</i>	<i>Page</i>
Table of the Ionic Order, Plates XI, XII, and XIII . . . . .	11	46
The Corinthian Order, Plates X and XI . . . . .	11	47
Table of the Corinthian Order, Plates XIV, XV, and XVI . . . . .	11	52
The Composite Order, Plates XII and XIII . . . . .	11	53
Table of the Composite Order, Plates XVII and XVIII . . . . .	11	57
Geometrical Relations . . . . .	11	57
Drawing . . . . .	11	65
The Greek Orders . . . . .	11	75
Pilasters, Plate XVI . . . . .	11	85
Pedestals, Plate XVI . . . . .	11	87
Attics . . . . .	11	91
Pediments, Plate XVII . . . . .	11	92
Intercolumniation, or the Spacing of Col- umns, Plate XVIII . . . . .	11	96
Doric Intercolumniations . . . . .	11	98
Superposition, Plate XVIII . . . . .	11	99
Other Cornices and String-Courses . . . . .	11	102
 <b>COLOR HARMONY</b>		
Introduction . . . . .	12	1
Primary Colors . . . . .	12	3
Secondary Colors . . . . .	12	4
Position of Colors in the Chromatic Scale . . . . .	12	4
Neutral Tints . . . . .	12	7
Producing Harmony . . . . .	12	7
Making a Color Card . . . . .	12	9
Plate, Historic Ornament . . . . .	12	11
Plate, Natural Forms . . . . .	12	21

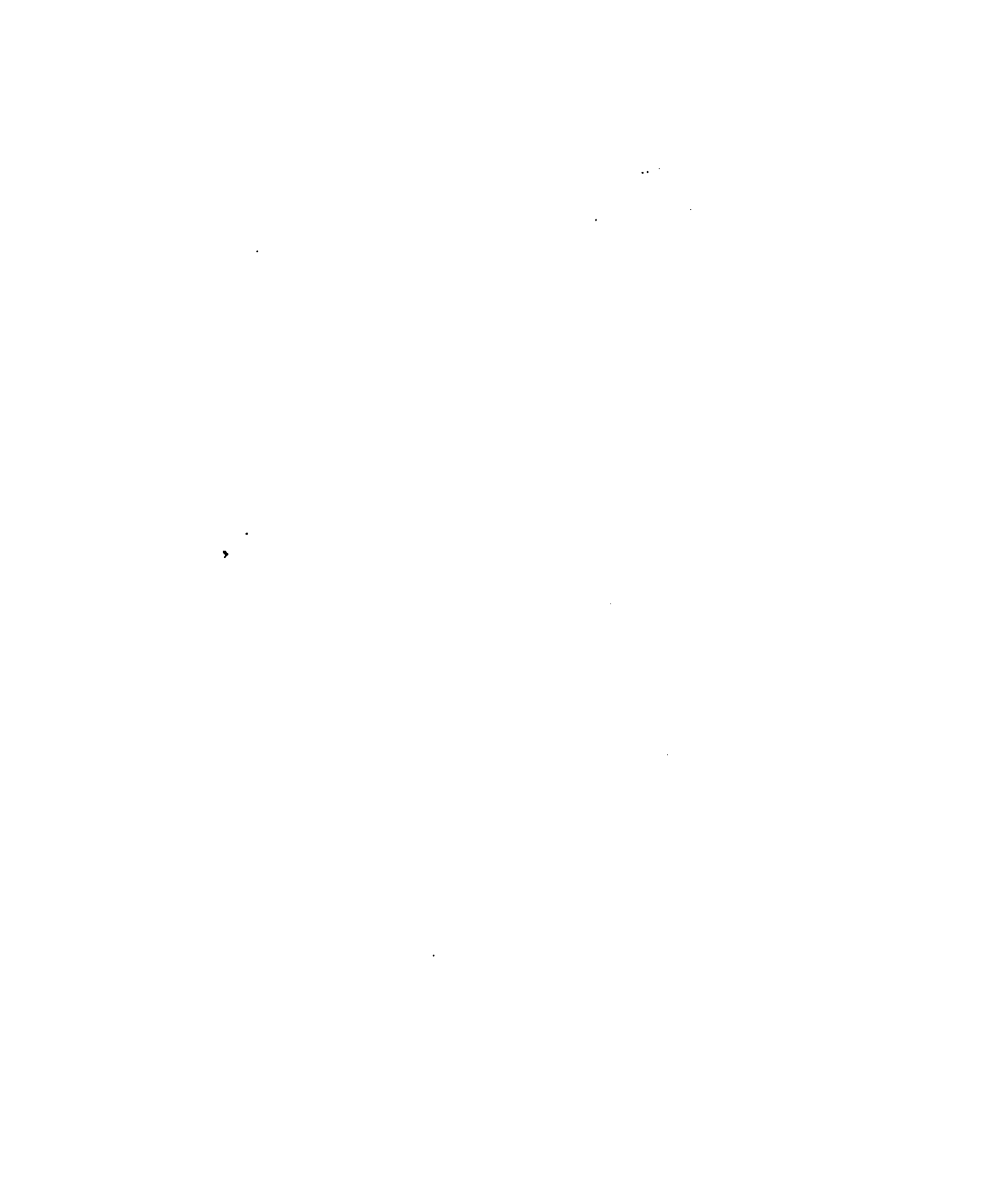

# INDEX

**NOTE.**—All items in this index refer first to the section and then to the page of the section. Thus, "Attics 11 91" means that attics will be found on page 91 of section 11.

	<i>Sec.</i>	<i>Page</i>		<i>Sec.</i>	<i>Page</i>
<b>A</b>					
Abacus, Explanation of . . . . .	11	10	Blocks, Explanation of . . . . .	11	18
American Vignola, The . . . . .	11	9	"    Outline . . . . .	9	1
"    Wilton rugs . . . . .	8	22	"    Preparing the . . . . .	9	1
Analogous harmony . . . . .	6	23	Blue and yellow colors . . . . .	12	4
Analysis of white light . . . . .	12	2	Bookbinding . . . . .	7	1
"    Plant . . . . .	5	1	"    Characteristics of		
Analytic study of plants . . . . .	5	14	Italian . . . . .	7	7
Arcade, Explanation of . . . . .	11	12	"    Early stages of the		
Arches, Explanation of . . . . .	11	12	art of . . . . .	7	1
Architrave, Explanation of . . . . .	11	12	"    18th century . . . . .	7	21
Architraves, Drawing of . . . . .	11	69	"    Heraldry in . . . . .	7	8
Artificial light on colors, Effect of . . . . .	6	12	"    Modern . . . . .	7	22
Astragal, Explanation of . . . . .	11	14	"    Origin of . . . . .	7	1
"    "    "    . . . . .	11	19	"    Tendency of early . . . . .	7	12
Attics . . . . .	11	91	Bookcover cartoons, Making the . . . . .	7	31
<b>B</b>					
Balusters . . . . .	11	88	"    design, Character of . . . . .	7	1
Balustrades . . . . .	11	88	"    "    Early influ-		
Band, Explanation of . . . . .	11	14	ences and		
Base of walls . . . . .	11	10	styles of . . . . .	7	5
Bead, Explanation of . . . . .	11	14	"    "    Evolution of a . . . . .	7	88
Beam, Explanation of . . . . .	11	12	"    "    Grolier style of . . . . .	7	5
Bed mould, Explanation of . . . . .	11	18	"    "    Jansen style of . . . . .	7	19
Bedroom wallpaper . . . . .	10	32	"    designing . . . . .	7	1
Bell of the capital, Explanation			"    designing, Requisites		
of . . . . .	11	19	for successful . . . . .	7	46
Binding, Character of modern . . . . .	7	22	"    designs governed by		
"    Cloth . . . . .	7	25	the tools, Early . . . . .	7	8
"    Extra . . . . .	7	25	"    designs, Origin of		
"    Half . . . . .	7	25	French tools for . . . . .	7	4
"    Hand and machine . . . . .	7	29	style of Louis XIV . . . . .	7	18
"    Mosaic . . . . .	7	19	"    of Margaret of		
"    Process of . . . . .	7	23	Valois . . . . .	7	17
"    Whole . . . . .	7	25	"    styles of Henry II and		
Bindings, Character of early . . . . .	7	2	Henry III . . . . .	7	17
"    Cheaper . . . . .	7	28	"    "    of Le Gascon and		
"    Classification of . . . . .	7	24	De Thou . . . . .	7	16
"    Derome . . . . .	7	20	Bookcovers, Classes of . . . . .	7	32
"    of different countries,			"    Francis I . . . . .	7	15
Comparison of . . . . .	7	22	"    Printed . . . . .	7	35
Black, Use of . . . . .	12	7	"    Tooled . . . . .	7	32
			Book plates . . . . .	7	47
			"    "    General types of . . . . .	7	50

	<i>Sec. Page</i>		<i>Sec. Page</i>
Broken spectrum colors, A working scale of . . . . .	6 21	Color, Red . . . . .	12 5
Brussels and Wilton carpets . . . . .	8 1	" scheme, Advantage of a good . . . . .	6 13
Building, Explanation of . . . . .	11 9	" schemes, Classification of . . . . .	6 14
		" " from nature . . . . .	6 29
		" " Natural forms that furnish . . . . .	6 29
<b>C</b>		" sense a necessity, Good . . . . .	6 9
Cap. Explanation of . . . . .	11 10	" Tertiary . . . . .	12 4
Capitals and bases, Drawing . . . . .	11 71	" The problem of . . . . .	8 4
" Explanation of . . . . .	11 10	Colored lights and colored pigments, Difference between mixing . . . . .	6 18
Carpet designing . . . . .	8 1	Colors . . . . .	9 16
" weaving, Frames for . . . . .	8 8	" Applying distemper . . . . .	6 8
Carpets, Brussels and Wilton . . . . .	8 1	" Blue and yellow . . . . .	12 4
" that may be formed into rugs, Designing . . . . .	8 13	" Contrast of . . . . .	12 10
Cartoons, Making bookcover . . . . .	7 31	" Effect of artificial light on . . . . .	6 12
Catering to the public . . . . .	9 10	" for wallpaper printing . . . . .	10 7
Cavetto, Explanation of . . . . .	11 14	" Grinding . . . . .	6 4
Chart, Making a color . . . . .	6 7	" in chromatic scale, Position of . . . . .	12 4
Choice of designs, Freedom in . . . . .	10 37	" most needed . . . . .	6 4
Chromatic scale, Position of colors in . . . . .	12 4	" Necessary proportions of . . . . .	12 7
Classes of bookcovers . . . . .	7 32	" of spectrum, Formation of . . . . .	12 3
" " color . . . . .	6 1	" Preserving the ground . . . . .	6 6
" " designs . . . . .	5 5	" Primary . . . . .	12 3
" " " . . . . .	9 13	" Secondary . . . . .	12 4
Classification of bindings . . . . .	7 24	" Semineutral . . . . .	12 5
" " color harmonies . . . . .	6 22	" Table of contrasts of . . . . .	6 17
" " " schemes . . . . .	6 14	Column, Explanation of . . . . .	11 10
" " wallpapers . . . . .	10 30	Columniation, Styles of . . . . .	11 96
Cloth binding . . . . .	7 25	Combinations of three hues, Table of . . . . .	6 28
Colonnade, Explanation of . . . . .	11 12	Comparison of bindings of different countries . . . . .	7 22
Color . . . . .	9 12	Complementary harmony . . . . .	6 23
" Artificial . . . . .	12 2	Composite Order . . . . .	11 21
" card, Making a . . . . .	12 9	" " Plates of the . . . . .	11 53
" chart C, spectrum scales, Preparing the . . . . .	6 14	" " Table of the . . . . .	11 57
" " Making a . . . . .	6 7	Congé, Explanation of . . . . .	11 14
" Classes of . . . . .	6 1	Contrast of colors . . . . .	12 10
" Distemper . . . . .	6 1	" Simultaneous . . . . .	6 16
" Distinction between transparent water color and distemper . . . . .	6 1	Contrasted harmonies . . . . .	6 23
" Green . . . . .	12 6	Contrasts of colors, Table of . . . . .	6 17
" Handling . . . . .	6 4	Conventional forms for designs, Evolving . . . . .	5 5
" harmonies, Classification of . . . . .	6 22	" rendering, Exercises in . . . . .	5 14
" harmony . . . . .	6 13	" units . . . . .	5 30
" " . . . . .	12 1	Conventionalism . . . . .	5 2
" inspiration, Sources of . . . . .	6 14	Conventionalization . . . . .	5 27
" matching . . . . .	6 9	Corinthian Order . . . . .	11 21
" Nature of . . . . .	12 1	" " Plates of the . . . . .	11 47
" Orange . . . . .	12 5	" " Table of the . . . . .	11 52
Color perception, Requisite in training . . . . .	6 30	Cornice . . . . .	11 10
" Perfect green . . . . .	12 6	" Explanation of horizontal . . . . .	11 92
" " orange . . . . .	12 5		
" Purple . . . . .	12 6		

INDEX

ix

	<i>Sec.</i>	<i>Page</i>		<i>Sec.</i>	<i>Page</i>
Cornice, Explanation of raking . . .	11	92	Designs, Freedom in choice of . . .	10	37
Cornices and string-courses . . .	11	102	" governed by the tools,		
" Drawing of . . . . .	11	67	Early bookcover . . .	7	3
Corona . . . . .	11	10	" Making the working		
Cover, Decorating the . . . . .	7	26	drawings of wallpaper	10	16
" design, Character of the . . .	7	26	" Modern . . . . .	7	26
" designs for zinc etchings . .	7	41	" Obtaining suggestions		
Covering material . . . . .	7	25	for . . . . .	8	18
Covers, Magazine . . . . .	7	30	" of wallpaper for special		
" Materials for . . . . .	7	28	rooms . . . . .	10	28
" Paper . . . . .	7	29	" Planted . . . . .	8	10
" " . . . . .	7	42	" Prices paid for wallpaper	10	20
Cyma, Explanation of . . . . .	11	14	" Rendering of . . . . .	10	19
" recta, Explanation of . . .	11	14	" Salable . . . . .	9	23
" reversa, Explanation of . .	11	14	" Sources of ideas for . . .	9	21
Cymatium, Explanation of . . . .	11	15	" The . . . . .	9	6
<b>D</b>					
Decastyle . . . . .	11	99	Die, Explanation of . . . . .	11	10
Decorating the cover . . . . .	7	26	Dining-room wallpaper . . . . .	10	31
Decoration, Principles of wall . .	10	22	Distemper color . . . . .	6	1
Decorative treatment . . . . .	5	22	" colors, Applying . . .	6	8
Denticulated Doric . . . . .	11	33	Distinction between transparent		
Derome bindings . . . . .	7	20	water color and distemper color	6	1
Design, Character of bookcover . .	7	1	Distyle . . . . .	11	99
" Evolution of a bookcover . .	7	38	Ditriglyph . . . . .	11	99
" for wallpaper, Laying out			Dodecastyle . . . . .	11	99
the . . . . .	10	12	Dominant harmony . . . . .	6	23
" " " Preparing			Doric, Denticulated . . . . .	11	33
the . . . . .	10	12	" intercolumniations . . . .	11	96
" Limitations of field of . . .	7	14	" Mutualy . . . . .	11	33
" Novelty of . . . . .	7	29	" Order . . . . .	11	21
" paper . . . . .	8	3	" " Plates of the . . . . .	11	30
" Preparing the . . . . .	9	14	" " Table of the . . . . .	11	38
" Propriety of . . . . .	7	27	" " The Greek . . . . .	11	76
" Tastes of different locali-			Drawing Plate, Title: Historic		
ties in style of . . . . .	10	27	Ornament . . . . .	12	11
Designer, Knowledge of styles			" " Title: Natural		
" necessary to the . . . . .	7	21	Forms . . . . .	12	21
" must be observant of			" the orders, General pro-		
public wants, Wall-			portions for . . . . .	11	65
paper . . . . .	10	45	Drawings as instruments of con-		
Designing . . . . .	8	5	" construction . . . . .	11	12
" Bookcover . . . . .	7	1	" Names of parts of . . . .	11	12
" carpets that may be			" of wallpaper designs,		
formed into rugs . . . . .	8	13	Making the working . .	10	16
" Oilcloth and linoleum . . .	9	1	" Preparing the . . . . .	7	38
" Requisites in success-			<b>E</b>		
ful bookcover . . . . .	7	46	Early bindings, Character of . . .	7	2
" Wallpaper . . . . .	10	1	Eaves . . . . .	11	10
Designs, Classes of . . . . .	5	5	Echinus, Explanation of . . . . .	11	19
" " . . . . .	9	13	Effects of artificial light on colors	6	12
" Evolving conventional			Elements of ornament . . . . .	5	1
forms for . . . . .	5	5	Ends . . . . .	8	2
" for rugs, Popular . . . . .	8	16	Enneastyle . . . . .	11	99
" " zinc etchings, Cover . .	7	41	Entablature, Explanation of . . .	11	12
			Entasis, Explanation of . . . . .	11	20

	<i>Sec.</i>	<i>Page</i>		<i>Sec.</i>	<i>Page</i>
Epistyle, Explanation of . . . . .	11	12	Inlay work . . . . .	9	5
Extra binding . . . . .	7	25	Intercolumniation, Explanation of plate of . . . . .	11	96
Extrados, Explanation of . . . . .	11	12	Intercolumniations, Doric . . . . .	11	98
<b>F</b>			Intrados, Explanation of . . . . .	11	12
Face, Explanation of . . . . .	11	14	Ionic Order . . . . .	11	21
Fanfares . . . . .	7	17	"    "    Plates of the . . . . .	11	39
Fascia, Explanation of . . . . .	11	14	"    "    Table of the . . . . .	11	46
Fillet, Explanation of . . . . .	11	14	"    "    The Greek . . . . .	11	79
"    Split . . . . .	11	92	"    "    volute, The . . . . .	11	61
Finishing . . . . .	7	23	Italian bookbinding, Characteris- tics of . . . . .	7	7
Floor . . . . .	11	10	<b>J</b>		
"    covering designs, Principles governing . . . . .	9	11	Jansen style of bookcover design	7	19
Forecasting styles of wallpaper . . . . .	10	20	"    "    "    design, Revival of the . . . . .	7	27
Forming new patterns . . . . .	8	15	<b>K</b>		
Forwarding . . . . .	7	23	Kitchen wallpaper . . . . .	10	32
Frames . . . . .	8	8	<b>L</b>		
Francis I bookcovers . . . . .	7	15	Lean-to . . . . .	11	9
Frieze, Explanations of . . . . .	11	12	Lettering . . . . .	7	56
<b>G</b>			Library wallpaper . . . . .	10	31
Gable . . . . .	11	9	Light, Analysis of white . . . . .	12	2
Geometrical relations of the orders	11	57	"    and shadow, Relation of . . . . .	12	2
Glass and other aids, Use of the repeating . . . . .	5	32	"    on colors, Effect of artificial	6	12
Greek Doric Order, The . . . . .	11	75	"    Standard of . . . . .	12	1
"    Ionic Order, The . . . . .	11	79	"    waves . . . . .	12	1
"    Orders, The . . . . .	11	75	Lines at 45 degrees . . . . .	11	59
Green color . . . . .	12	6	"    "    60 degrees . . . . .	11	60
"    "    Perfect . . . . .	12	6	<b>M</b>		
Grinding colors . . . . .	6	4	Machine binding, Hand and . . . . .	7	29
Grolier style of bookcover design	7	5	"    printed papers, Difference between hand-printed and . . . . .	10	6
Ground colors, Preserving the . . . . .	6	6	"    printing . . . . .	9	4
<b>H</b>			"    "    of wallpaper . . . . .	10	3
Half binding . . . . .	7	25	Magazine covers . . . . .	7	36
Hall wallpaper . . . . .	10	30	Manufacture of wallpaper . . . . .	10	1
Hand and machine binding . . . . .	7	29	Materials for covers . . . . .	7	28
"    printed and machine-printed papers, Difference between	10	6	Medium to be used in specific cases . . . . .	6	2
"    printing . . . . .	9	3	Metope, Explanation of . . . . .	11	36
"    "    of wallpaper . . . . .	10	1	Mixing colored lights and colored pigments, Difference between . . . . .	6	18
Harmonies, Contrasted . . . . .	6	23	Modern bookbinding . . . . .	7	22
Harmony, Analogous . . . . .	6	23	Modillions, Explanation of . . . . .	11	13
"    Color . . . . .	12	1	Monotriglyph . . . . .	11	99
"    Complementary . . . . .	6	23	Mosaic binding . . . . .	7	19
"    Dominant . . . . .	6	23	Moulding, Explanation of thumb . . . . .	11	14
"    Producing . . . . .	12	7	Mouldings . . . . .	11	18
Heptastyle . . . . .	11	99	"    Styles of . . . . .	11	17
Heraldry in bookbinding . . . . .	7	3	Mutulary Doric . . . . .	11	33
Hexastyle . . . . .	11	99	Mutules, Explanation of . . . . .	11	18
Hip . . . . .	11	9			
Horizontal cornice, Explanation of	11	92			
"    valley . . . . .	11	9			
Hue or tone, Ways of changing the	6	10			

INDEX

xi

N		Sec.	Page	Sec.		Page
Natural forms on ornament, Influence of . . . . .	5	11	Pilasters, Explanation of plate of . . . . .	11	85	
"    "    that furnish color schemes . . . . .	6	29	Plans, sections, elevations, and perspective views, Subdivision of drawings into . . . . .	11	12	
Nature of color . . . . .	12	1	Plant analysis . . . . .	5	1	
"    study . . . . .	5	13	"    life, Studies of . . . . .	5	18	
Necking, Explanation of . . . . .	11	19	Planted designs . . . . .	8	10	
Neutralize, Meaning of . . . . .	12	5	Planting, Meaning of . . . . .	8	9	
Neutral tints . . . . .	12	7	Plants, Analytic study of . . . . .	5	14	
O				Plinth, Explanation of . . . . .	11	20
Octastyle . . . . .	11	99	Popular designs for rugs . . . . .	8	16	
Oilcloth and linoleum designing . . . . .	9	1	Portraiture not aimed at . . . . .	5	28	
Oilcloths, Printing . . . . .	9	1	Post, Explanation of . . . . .	11	10	
Orange color . . . . .	12	5	Preserving the ground colors . . . . .	6	6	
"    "    Perfect . . . . .	12	5	Prices paid for wallpaper designs . . . . .	10	20	
Order, The Greek Doric . . . . .	11	75	Primary colors . . . . .	12	8	
"    "    "    Ionic . . . . .	11	79	Principles of wall decoration . . . . .	10	22	
Orders, Five . . . . .	11	21	Printed bookcovers . . . . .	7	35	
"    General proportions for drawing the . . . . .	11	65	Printing, Hand . . . . .	9	8	
"    Geometrical relations of the . . . . .	11	57	"    Machine . . . . .	9	4	
"    Proportions of the . . . . .	11	27	"    of wallpaper, Hand . . . . .	10	1	
"    The . . . . .	11	17	"    "    "    Machine . . . . .	10	8	
"    "    five . . . . .	11	9	"    oilcloths . . . . .	9	1	
"    "    Greek . . . . .	11	75	"    process, The . . . . .	9	8	
Oriental rugs . . . . .	8	19	Problem of color, The . . . . .	8	8	
Originality an essential . . . . .	9	23	Process of binding . . . . .	7	28	
Ornament, Elements of . . . . .	5	1	Profile, Explanation of . . . . .	11	14	
"    Influence of natural forms on . . . . .	5	11	Proportioning of masses, Influence of . . . . .	6	27	
Outline blocks . . . . .	9	1	Proportions, Importance of proper "    of colors, Necessary . . . . .	12	7	
Outlining and rendering . . . . .	5	15	Propriety of design . . . . .	7	27	
Overelaboration to be avoided . . . . .	5	17	Purple color . . . . .	12	6	
Ovola, Explanation of . . . . .	11	14	R			
P				Raking cornice, Explanation of . . . . .	11	92
Paper covers . . . . .	7	29	Red color . . . . .	12	5	
"    "    . . . . .	7	42	Rendering, Exercises in conventional . . . . .	5	14	
"    Design . . . . .	8	3	"    of design, Style of . . . . .	7	56	
Parapet, Explanation of . . . . .	11	10	"    "    wallpaper designs . . . . .	10	19	
Parapets . . . . .	11	88	"    Outlining and . . . . .	5	15	
Parlor or drawing-room wallpaper . . . . .	10	30	"    Simplicity and freedom of . . . . .	5	15	
Patterns, Forming new . . . . .	8	15	Repeating glass and other aids, Use of . . . . .	5	22	
"    Styles of . . . . .	9	6	Repeats, Standard . . . . .	8	12	
Pedestal, Explanation of . . . . .	11	10	Reproduction of Persian rugs . . . . .	8	21	
Pedestals, Explanation of plate of . . . . .	11	87	Reproductive processes necessary, Knowledge of . . . . .	7	81	
Pediments, Explanation of plate of . . . . .	11	92	Revival of the Jansen style of design . . . . .	7	27	
Pentastyle . . . . .	11	99	Ridge . . . . .	11	9	
Perfect orange color . . . . .	12	5	Rollers for machine printing, Method of making the . . . . .	10	4	
Persian rugs, Reproduction of . . . . .	8	21	Roofs, Shapes of . . . . .	11	9	
Pick . . . . .	8	2				
Pier, Explanation of . . . . .	11	10				



	<i>Sec.</i>	<i>Page</i>		<i>Sec.</i>	<i>Page</i>
Rugs, American Wilton . . . . .	8	22	Tints, Formation of neutral . . . . .	12	7
" Oriental . . . . .	8	19	" Neutral . . . . .	12	7
" , Reproduction of Persian . . . . .	8	21	Tooled bookcovers . . . . .	7	32
Rules . . . . .	8	3	Tooling, Modern tools and . . . . .	7	32
<b>S</b>			Tools and tooling, Modern . . . . .	7	32
Salable designs . . . . .	9	23	" for bookbinding . . . . .	7	3
Scotia, Explanation of . . . . .	11	14	" " bookcover design, Origin of French . . . . .	7	4
Secondary colors . . . . .	12	4	Torus, Explanation of . . . . .	11	14
Securing the sheets . . . . .	7	23	Treatment, Decorative . . . . .	5	22
Semineutral colors . . . . .	12	5	Triads . . . . .	6	27
Shadow . . . . .	12	2	Tristyle . . . . .	11	99
" Relation of light and . . . . .	12	2	Tuscan Order . . . . .	11	21
Shaft, Explanation of . . . . .	11	10	" " Plates of the . . . . .	11	29
Shanks, Explanation of . . . . .	11	36	" " Table of the . . . . .	11	30
Sheets, Securing the . . . . .	7	23	Tympanum, Explanation of . . . . .	11	92
Simultaneous contrast . . . . .	6	16	<b>U</b>		
Sketch should represent finished object, Submitted . . . . .	6	2	Units, Conventional . . . . .	5	30
Soffit, Explanation of . . . . .	11	12	<b>V</b>		
Space filling . . . . .	5	27	Valley, Horizontal . . . . .	11	9
Spandrel, Explanation of . . . . .	11	12	Vault, Explanation of . . . . .	11	12
Spectrum colors, A working scale of pure . . . . .	6	19	Vertical lines . . . . .	11	63
" Formation of colors of . . . . .	12	3	Vignola, The American . . . . .	11	9
" hues, Table of com- bined pairs of . . . . .	6	26	Vignola's Orders, Plate of . . . . .	11	27
" scales . . . . .	6	14	Volute, The Ionic . . . . .	11	61
" The . . . . .	12	3	<b>W</b>		
Split fillet . . . . .	11	92	Wall decoration, Principles of . . . . .	10	22
Stamping and printing processes, Various technical . . . . .	7	35	Wallpaper, Bedroom . . . . .	10	32
Standard repeats . . . . .	8	12	" designer must be ob- servant of public wants . . . . .	10	45
Studies of plant life . . . . .	5	18	" designing . . . . .	10	1
Study, Nature . . . . .	5	13	" designs for special rooms . . . . .	10	28
Stuffing warp . . . . .	8	2	" " Prices paid for . . . . .	10	20
Style of design, Tastes of different localities in . . . . .	10	27	" " Rendering of . . . . .	10	19
" " wallpaper, Examples of prevailing . . . . .	10	43	" Dining-room . . . . .	10	31
" " " Forecasting . . . . .	10	20	" Forecasting styles of . . . . .	10	20
Styles of patterns . . . . .	9	6	" Hall . . . . .	10	30
Superposition, Explanation of plate of . . . . .	11	99	" Hand printing of . . . . .	10	1
<b>T</b>			" Kitchen . . . . .	10	32
Table of combinations of three hues . . . . .	6	28	" Library . . . . .	10	31
" " combined pairs of spec- trum hues . . . . .	6	26	" Machine printing of . . . . .	10	3
" " contrasts of colors . . . . .	6	17	" Manufacture of . . . . .	10	1
Tænia, Explanation of . . . . .	11	19	" Parlor or drawing- room . . . . .	10	30
Tertiary color . . . . .	12	4	" Preparing the design for . . . . .	10	12
Tetrastyle . . . . .	11	99	" printing, Colors for . . . . .	10	7
Threads, Warp . . . . .	8	2	Wallpapers, Classification of . . . . .	10	30
Thumb moulding, Explanation of . . . . .	11	14	Walls, Base of . . . . .	11	10

# INDEX

xiii

	<i>Sec.</i>	<i>Page</i>		<i>Sec.</i>	<i>Page</i>
Warp, Stuffing . . . . .	8	2	Wilton rugs, American . . . . .	8	22
"    threads . . . . .	8	2	Working drawings of wallpaper		
Ways of changing the hue or tone	6	10	designs, Making the . . . . .	10	16
Weft . . . . .	8	2	"    scale of broken spec-		
White light, Analysis of . . . . .	12	2	trum colors, A . . . . .	6	21
Whole binding . . . . .	7	25	"    "    of pure spectrum		
Wilton carpets, Brussels and . . . . .	8	1	colors, A . . . . .	6	19



# PLANT ANALYSIS

---

## INTRODUCTION

1. In preparing a design for any purpose whatsoever, one must have a type or form on which to base it. These types are usually considered **elements of ornament** and may be divided, generally speaking, into two distinct classes—the artificial and the natural—and although these are subdivided into three classes, it is not necessary to enumerate them except as they appear.

A designer should have clearly before his mind the general characteristics of the type or form or element of ornament on which he is to base his design, and should be able to work intelligently from this point to the completion of his design. In order to do this, it is necessary that he shall have studied the designs of others and be able to analyze them for their good points, or to criticize their poor points. If he has these designs close at hand when he is working out a design, they may be of assistance to him, but under no circumstances should he copy the idea or the details of another design, as by so doing he becomes a simple machine and an imitator and tends to destroy his own originality and make himself dependent on the originality of others.

While many designers depend entirely for their motifs on the efforts of some one else, the successful designers are those that are independent of such methods and take their inspiration directly from nature. It is not unusual to see the carpet designer appropriate the work of the wallpaper designer without considering the fitness of the pattern to its application or purpose. On the other hand, the average wallpaper designer tends to get into a rut and make his design simply

variations of the designs of others, instead of inventing them himself. In recent years there have been many publications of plant studies and other floral forms that furnish motifs on which designs will be built, and though excellent in themselves these motifs are public property and are sought and seized by so many designers that they soon become commonplace and we see them applied to all sorts of things.

It is a waste of time for any designer to learn to apply the designs of others; the factory does this, and it is useless to waste time copying designs that have already been manufactured, except where such copying may be required to learn the technique. If the American designer could be thoroughly impressed with the uselessness of adapting the designs of others, the leading manufacturers and merchants of this country would not go abroad for their designs, as they do at present.

The designer must be able to draw and to color, and must understand the principles and elements of design; then, with the requisite material to build up a pattern, he can create one that is entirely and exclusively his own. Suggestions may be drawn from the great historic styles of conventional ornament, but they must be used with the greatest judgment in all fields of design. But the great fountain head for inspiration is nature, in all its forms. Nature furnishes an inexhaustible supply of material that can be suited to any purposes of design whatsoever. However, in adapting nature forms to the purposes of design they must always be more or less conventionalized.

---

#### CONVENTIONALISM

**2. Definition of Conventionalism.**—One of the greatest difficulties that the beginner in design experiences is the proper appreciation and application of *conventionalism* in his work. To the untrained mind, conventionalism is symbolic of stiffness, but nothing could be further from the truth. Simply stated, **conventionalism** consists in adapting the form to the purpose and material for which the

design is made; it is a simple treatment of natural forms made necessary by the simple laws of beauty.

A certain amount of naturalistic rendering can be combined with conventionalism in some instances, whereas in others the conventionalism can be carried to so severe an extent that the natural form on which it is based is entirely lost. The designer can adapt to his purpose a form in nature, but can conventionalize it so that it no longer represents the form. However, it will be ornamental and therefore worthy of its own existence. The Egyptian lotus, as seen carved and painted on the walls of the tombs and temples, is sufficiently like a lotus to call to mind the flower, and we accept it as a decoration and do not criticize it as a portrait. On the other hand, the Greek anthemion is a similar decoration, but entirely free from any suggestion of the honeysuckle or other type on which it may have been based. The former is a case of conventionalism that does not destroy the type; the latter, a case where conventionalism has been carried so far that the original motif has become extinguished.

**3.** In this age, the artist and the manufacturer are inclined to be carried away by skill in handiwork, to the exclusion of proper brain application. The evidence of skill in a finished fabric is entirely out of place, unless the skill is intimately associated with the design. We see the weaver and the loom fixer delighted as they display to us in triumph what appears to be a very commonplace portrait or engraving executed in monochrome. It is a picture, but woven on the loom. Infinite pains have been taken to arrange the machine and details of the harness or jacquards to produce something that is entirely out of place and outside of the province for which the loom was invented. If a picture were wanted, an infinitely better picture could have been produced by other means; and if a fabric were wanted, a superior fabric could have been woven with a more conventional design. Here we have but a poor imitation of the engraver's art executed by the weaver. What would we say were the



FIG. 1

problem reversed, and the engraver should execute his pictures to appear as though they were composed of silk or cotton? In either case the fabric is useless for what it is, and unsuitable for what it imitates.

Any object of art should appear exactly and honestly to be just what it is, and to be most pleasing and satisfactory it must present the appearance of having been produced with great ease, and not with infinite pains. The simpler the appearance of a design, usually the more brain work is spent in making it. The loom has a legitimate province that should not be lowered or degraded by making it produce freaks. Conventionalism, therefore, consists in preparing natural forms to suit them to the material in which they are to be executed.

**4. Classes of Designs.**—Designs in general can be divided into three classes: (1) those that are purely naturalistic and reproduce pictorially the form or type on which they are based, as shown in Fig. 1; (2) those that are semiconventional or decorative—a combination of naturalistic rendering with but slight modification, in order that it may be printed, woven, or stamped on the fabric which receives it without pretending to be different from what it is, as shown in Fig. 2; (3) those that are purely conventional, and do not pretend in any way to represent the natural form on which they are based, except to recall it to the mind, as shown in Fig. 3.

**5. Evolving Conventional Forms for Designs.**—The evolving of conventional forms from nature requires not only ingenuity but also a very good sense of what is fitting in design. It necessitates an artificial training in contradistinction to nature treatment that is a mere copying of a natural form. Conventional rendering is a step in advance of nature rendering, although many persons, ignorant of the principles of art and design, are inclined to look on it as a degrading of nature's forms to suit the necessities of machinery printing or weaving, and consequently an improperly trained designer endeavors to disguise the fact that his





FIG. 2

design is made by the machine and tries to represent it as a piece of hand work. This is entirely a wrong idea; just as wrong as the rendering of a picture would be in a piece of textile fabric. Machine work at its best does not possess the soul and individuality of hand work, and often a mediocre piece of machine work is better than an excellent reproduction of hand work, since it tells the truth. Nature furnishes us with an abundance of raw material that is acted on by the lines of the artist and transmuted into ornament. It cannot be accomplished without taxing the highest intellectual faculties that the designer possesses—his powers of invention and creation. It will be observed in the study of historic ornament that each period when ornamental design reached a high standard has been marked by a more than ordinarily popular existence of the standard of the most cultivated artists; and so, should the public become so trained that its taste is in accordance with that of the best artists, we shall again have the period of perfect and universal art similar to that which existed in Greece during the age of Pericles.

In purely naturalistic design, irregularity or diversity of arrangement is aimed at; the simulation of the picturesque element in nature is what the designer strives for. He endeavors to duplicate light and shade effects, dainty gradations of color, peculiar and even decided forms of leaf and flower, and to counterfeit the original in every detail. When such an artist endeavors to apply his talents to designing, his productions are in no way suited for the purpose because they are not fit for printing or weaving by mechanical means, and as a consequence the highest grade of mechanical skill and machinery is required to produce them. This is a direct waste of good energy. A student, especially a beginner, should avoid rendering purely naturalistic designs. There is plenty of opportunity to dispose of designs that are less beautiful in artistic merit and call for less skill and inventive genius in manufacture. The designs that the manufacturer most desires are those that are beautiful in themselves and require the least effort in converting into a finished fabric.



FIG. 3

6. Lewis F. Day, one of the greatest English designers, says in his textbook on ornamental design: "To introduce an element into ornament is simple enough. The difficulty is to know just how far it should be allowed to go. It is so fascinating, so seductive, so self-satisfying that it threatens the very existence of decorative art, yet where shall we draw the line? It is as difficult to make ornament natural enough to satisfy the public as it is to modify nature to sufficiently please the ornamenters. Good art and nature are always encroaching one on the other, as the sea upon the shore and the shore upon the sea. In every generation the coast rectifies itself, and every day tides vary. It becomes, therefore, quite impossible to define rigidly the elements of nature and of art in ornament. The cautious man will always keep carefully within bounds, the adventurous will as surely be attracted by the beauties that belong to the border land, and the very sense of danger will quicken his delight in them."

William Morris, the celebrated craftsman and writer, says: "Beauty combined with invention and founded upon careful observation of nature is the mainspring of decorative design. If a design is not beautiful it has no right to exist; if it is not inventive it becomes wearisome; and if it is not founded upon observation of nature, it is not likely to be either beautiful or inventive."

In Fig. 4 are represented several of Mr. Morris's designs, and one can see that he was frequently attracted by beauties that belong to the border land between nature and invention. There is much to be studied concerning this so-called border land, which really embraces what was previously referred to as a decorative treatment of natural forms. This border land is not a safe ground for the student, especially the beginner, to study, but it is a sort of middle ground between purely naturalistic rendering and the conventional rendering, on which the skilled designer and the unskilled public can meet and both experience a certain amount of satisfaction. The inexperienced public requires a design that is a counterfeit of nature, the cautious designer prefers a design that pretends to be nothing more than what it is,



FIG. 4

but is in itself beautiful. The designs on this so-called middle ground imitate nature sufficiently to suit the public and at the same time call on the designer to use all his ingenuity and powers of invention in conformity with the laws of beauty. During every period of history imitative ornament has been popular with the people at large. It is doubtful whether at any time pure ornament, as such, has been popular. A comparative small minority of highly cultivated artists may have imposed their tastes on a people for a time, or a deep religious belief may have sufficed to counteract the natural leaning toward natural forms; but for all that the leaning is natural.

**7. Influence of Natural Forms on Ornament.**—In no case is pure ornament entirely independent of nature, as nature is the source of all ornament that is beautiful in form. If it were not for the influences of nature in natural forms, man's imagination would be incapable of producing the grace, the growth, the flow of line and delicacy that delight us in a satisfactorily executed design. These influences are usually undetected and indirect, so indirect in fact that the majority of persons do not feel them at all. But if the masses are to be led to ultimately appreciate ornament in its purest sense, they must be led gradually to the style of decoration that is distinctly allied to imitation.

The approach to ornament, pure and simple, for its own sake must be gradual and cautious, for if the departing from imitation be too sudden the minds of the masses will not grasp the situation and will give up their progress of improvement and go back to their old naturalistic renderings. At the present time there is being introduced into this country a very powerful influence on design, usually called *L'Art Nouveau*, a French term meaning new art, although as a matter of fact there is nothing new about it. Its origin in France and Germany was probably due to a revulsion of feeling against the continuous copying of old conventional styles.

**8. L'Art Nouveau** is simply an attempt to create something fresh and original and inspired by nature. Like

everything new and popular, it has been greatly abused by its improper application to architectural forms without proper thought. The inventors or creators of L'Art Nouveau went to nature for their inspirations, whereas many of the so-called designs executed in this style are simply copies of other designs without any direct inspiration of nature at all. Notwithstanding this, we find the graceful lines and the novel arrangements of the masses that especially adapt this style of decoration to surface work. It resembles strongly the Japanese method of working and has undoubtedly been inspired somewhat by this nation, who are very close students of nature and have shown an especial appreciation of the decorative in nature. They have taught us how to group and compose new forms effectively, both in groups and as single objects, and this without any violation of the laws of proportion, balance, and harmony, by the use and application of the subtle curves and arrangements that discerning students ever find in nature. In other words, the Japanese are noted for instilling into their designs natural curves without copying the plant itself nor yet departing entirely from the naturalistic rendering.

While we will never arrive at any definite agreement with the public concerning how much naturalistic rendering shall be included in a design and to what extent natural forms shall be conventionalized, we must be assured that the designer, to make any progress in originality, must be inventive and ingenious, and must draw inspiration from nature.

### NATURE STUDY

9. Although the subject of this Section is plant analysis, it must not be confused with botanical analysis. In the present case we are concerned simply with the appearances and general aspects of the plant and its various parts in so far as they can be used as ornament. We are not concerned with the functions of these parts nor with the physiological relations, as in the study of botany. In studying plant analysis, we must take into consideration the leaves and the blossoms as well as the general growth and characteristics of growth that are observable in the plant. This means that we must study the character of the stems, their manner of branching, the attachment of the leaves and the blossoms, and the general appearance of the roots.

A maple tree is essentially different in appearance from a poplar tree; this we are able to recognize at once owing to its difference in growth. Closer inspection shows a difference in the form and color of the leaves, in the manner in which the leaves branch from the stems, etc. It is not these minor differences, however, that enable us to determine, at a glance, the difference between two kinds of trees. In the smaller growths, such as shrubs, vines, and single flowers, we are not so familiar with the characteristic differences as to be able to recognize at a glance one plant from another, unless it be in blossom or unless its characteristic feature be very evident. The ordinary student, however, must give attention to these characteristic features and intelligently apply them in his decorated designs without violating any natural law but simply applying natural laws to decorative purposes. In order to accomplish this, a series of drawn studies should be made of flowers and of leaves, not only singly, but also in clusters. Positions of various parts should be changed, care being exercised to so arrange them that the views will bring into prominence the most characteristic details of each plant.



**10. Analytic Study of Plants.**—In making analytic studies of flowers, the blossom should be first drawn as it appears in nature, accompanied by two or more leaves. It should then be pulled apart and each petal drawn separately. The removal of the petals may leave naked the calyx and pistils, which also should be studied. The part remaining after all the petals have fallen from natural causes is frequently as interesting as the entire blossom. Here is the matured seed vessel from which the infant plant will eventually spring; therefore, here is the material for a new series of study and endless changes may be expressed from the sprouting of the seed to the matured fruit. This in its application to design may form the theme of the entire design more prominently than the characteristics of the flower itself. A growing plant is full of interest, a growing design is likewise full of interest, and the subject on which a design is placed can be delicate or strong.

The designer must be so familiar with various types of plant that he can draw them from memory or construct them in detail from scanty and hurriedly made notes.

**11. Exercises in Conventional Rendering.**—As an exercise in this branch of study, arrange on a sheet of drawing paper a series of drawings of any simple plant arranged somewhat as shown in Fig. 5. These should be drawn carefully in pencil and then filled in with flat washes of color and outlined with a heavy dark line laid on with a small brush. No attempt at light and shade should be expressed, although more than one tone may be employed in order to express the different parts if it is necessary in order to make the rendering more intelligible.

No attempt should be made to maintain a continuous wash from one part to another. For instance, where two sides of a leaf are expressed, the rib down the center can best be expressed by leaving a narrow stripe of the white paper. The colors used need not necessarily be the exact shades that indicate the plant nor even the color of the blossoms, as these are decorative studies and not portraits of the flower,

FULLER  
ACTING  
THE



8-55

FIG. 5

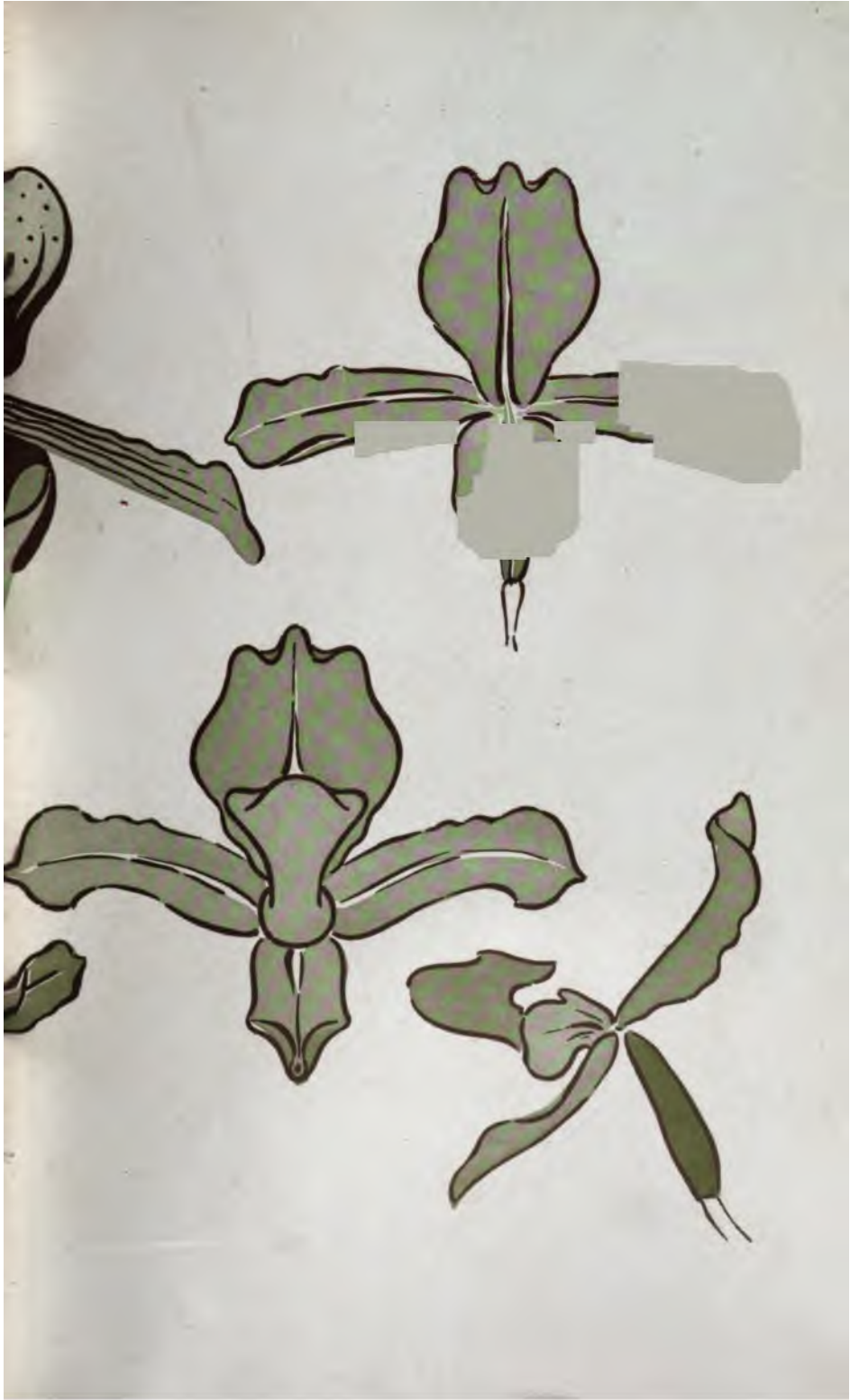

10  
A  
TH. DEB

and the student must learn at once that in using a given plant as a basis of design he is at perfect liberty to represent the conventional form of that plant in any color he chooses. In wallpaper, carpet, and other mechanically reproduced designs, we frequently see flowers and their leaves expressed in two tones of the same color or in tones of different colors, neither of which is the characteristic color of the original flower or leaf. Without proper thought this may seem at first incongruous, but in this independence of color scheme lies the key to conventionalism. We adopt a floral form because it is beautiful; we adapt it to the purpose of design by reducing it to a conventional form and it then no longer becomes a naturalistic flower and need no longer possess a naturalistic color. If we make a drawing or a painting of any natural scene in pencil or in India ink, or in brown sepia, the finished sketch is pleasing to the eye and no one demands that the tree should be green and the sky should be blue, because we recognize that the drawing is made in sepia or in black and white. On the other hand, when we reproduce a conventionalized floral form in a carpet or in a wallpaper, no one should demand that the roses should be red and the leaves should be green, for he should understand that this is a decoration and not a portrait.

Adherence to the positive colors expressed in nature is the cause of many unsatisfactory designs, and the beginner can do better work when he realizes that his color harmony is independent of his basis of design.

---

#### OUTLINING AND RENDERING

**12. Simplicity and Freedom of Rendering.**—Let the outlines in all drawings of plant analysis be bold and free. Do not attempt to make them stiff, symmetrical, or thin and unvaried in width. Let them break at intervals where it is convenient to stop the end of a stroke. Let all drawings be truthful, and if a line is drawn in two strokes with a brush or pencil, do not make it appear as if it were drawn in one stroke. Observe, in Fig. 6, a Japanese drawing of the leaf

and fruit of the native currant. No attempt has been made here to detail each form laboriously. The whole is sketched in rapidly but skilfully, and expresses in the outline and veining of the leaf, in the jagged irregularity of the stem, in the peculiar clustering of the fruit and the curling of the



FIG. 6

tendrils, all the characteristics of this plant. The American grape is similar to it and possesses similar characteristics, except the bunches of the fruit are different in form.

The student should make a series of not less than ten studies like that shown in Fig. 5, using a separate type of

plant for each study. The work can be varied from time to time by indicating the effect of light and shade by using two tones, each tone, however, being expressed as an independent wash from its neighbor and not as a blending of one tone into another. Great care must be exercised or the study will degenerate into a naturalistic treatment. Do not forget the purpose for which the study is being made. When pictures are wanted, take the time to make good shaded drawings with pencil or water color; but in studying plant analysis for design purposes, bear in mind that the design represents characteristics common to every plant of its kind and not the characteristics of some individual specimen. In rendering the views of the leaves in Fig. 5, the back of the leaf, where it shows in the side view, could be rendered a lighter or a darker color than the front of the leaf, as this would likely be the case in nature, or one side of the leaf might be lighter and darker in color than the opposite side, the line of demarcation being expressed by the vein. These two sides could be expressed in different tones, but this should be characteristic of all leaves and not expressed to represent any particular specimen.

**13. Overelaboration to Be Avoided.**—The noticeable inferiority in the work of beginners is an evidence that much time has been spent in elaborating some unnecessary and useless detail, such as the accidental discoloration of a flower or a leaf, or the worm eaten parts of a plant, while he has overlooked other details that are characteristic of the growth itself. Worm holes are not a detail of plant study from an art standpoint. If a design were to include insect life as well as plant life it might be well to express the details arising from the relations of one to the other, but accidental formations, discolorations, and deformities form no part of the conventionalizing of natural forms.

The drawing may express the fullness of life and vigor of the plant. Specimens for study should be typical of the species, and should be gathered while they are in full maturity and in the best of condition. Many plants wither



almost immediately after being cut; these should, as frequently as possible, be studied while growing.

Another characteristic of the beginner's work is his tendency to exaggerate details. His tendency in drawing a small object is to make it too small and of a large object to make it too large. Large, vigorous leaves and blossoms are frequently perched on the end of a thin, puny stem that in reality would not be able to transmit sap enough to support them. The tendency in the other direction is far more commendable if not carried to excess. The stem can afford to be thickened in plant analysis beyond its natural form and large leaves and flowers may be reduced. In the analysis of small flowers it is far better that they should be drawn on a larger scale than on their own or a smaller scale. A magnifying glass will assist the student in this work.

**14. Studies of Plant Life.**—Studies of stems, both soft and woody, should be made by themselves. Tendrils and seed cupules of various kinds should also be studied. These forms are not so interesting to the designer and are apt to be overlooked, or when introduced into a design are badly expressed owing to the fact that the designer has not given them proper attention. Practical work of this kind will fix in the mind the important relation that these forms bear to the character of the whole plant. Fig. 7 illustrates some studies of this character executed by students in design. Studies of this character should be frequently made and preserved for future reference.

In Fig. 8 is shown an analysis of the common dandelion. This simple little flower is rich in suggestion and the various renderings of it in this illustration serve to emphasize its characteristics. Note the beautiful rendering of the sharply indentated leaf, the delicate, crystal-like, globular enclosure of the seed vessel, the simple, star-like expansion of the full blossom, and the relation of light and shade values in the conventional cluster including all three forms. The light and shade here is not natural but conventional; the background leaves are lighter than the foreground leaves and

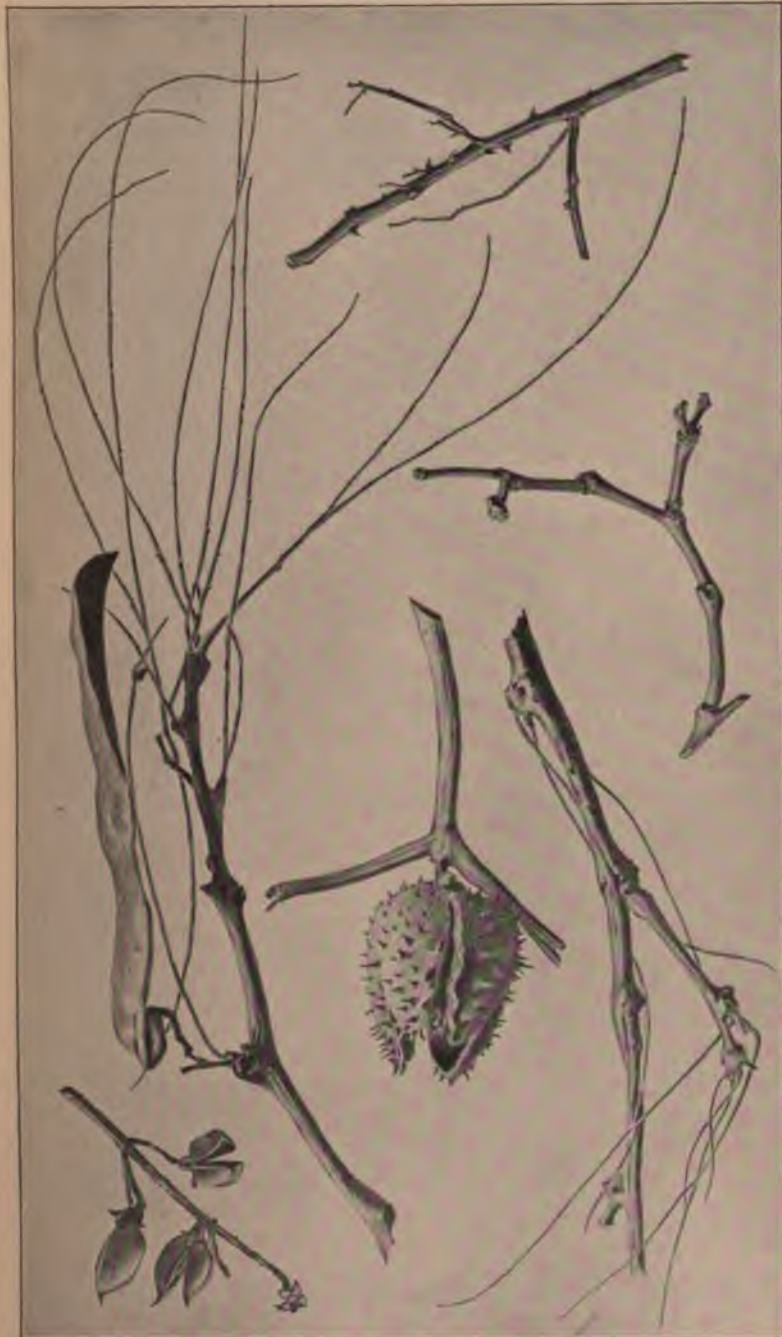

FIG. 7



FIG. 8

show their positions by contrast of color. The stems are occasionally expressed by a darker tone and equally often by a lighter tone or a strip of white showing through. No attempt has been made at portraiture, but simply a record of the characteristics of the plant. It may be pointed out again right here that drawing bears the same relation to design that writing does to literature; each is a method of making a record of what we see or what we think. If one could write out the details of a flower and express it to his fellow creature as well as by drawing, writing might be the medium of expression instead of drawing. Nations that possess no simplified form of handwriting convey their ideas to one another by means of drawings, an abundance of which are found in the hieroglyphs of Egypt. Therefore, studies like those shown in Fig. 8 should simply be graphic records of facts. Fig. 9 shows the further application of such graphically recorded facts in a design wherein the sinuous character of the natural stem



FIG. 9

growth is taken advantage of to fill the spaces between the *spots* formed by the blossoms. It is easily recognizable that Fig. 9 is not a portrayal of nature, but it possesses all the characteristics of the natural growth.

In Fig. 10 is shown another study by a student wherein the

application of the natural form to various purposes is illustrated. In the upper left-hand corner is a naturalistic rendering or portrayal of the scarlet nasturtium. The form of the blossom and bud together with the stems and leaves are clearly illustrated, while just below them the conventional rendering of the blossom and leaves shows their reduction to conventionalized forms for the purposes of design. Rosettes are made up of the details of the growth. Suitable ornamental forms for borders or panel decorations are made up of combined leaf and blossom effects, while at the lower right-hand corner the bud, the blossom, the soft twining stems, and flat, nearly circular, leaf are combined in a regular pattern that expresses in the most conventional manner the principles of growth rather than the character of the flower itself.

Every plant is just as worthy of study as the nasturtium, though some lend themselves more readily than others to application in decorative design. These, therefore, are more frequently seen in design. The most prominent in these characteristics is the rose, both the single wild rose and the double or cultivated rose. The former of these is easy to draw, exceedingly adaptable to any kind of decorative treatment, and is therefore more prominent than any other floral form in our modern decorative motives. The poppy seems to be next in favor, and this admits of even a wider diversity of treatment than does the rose, owing to the greater variety in the form of the leaf and the flower, but it is more difficult to draw and therefore does not find so much favor with the unskilled. But the iris, peony, thistle, daffodil, hollyhock, and numerous other bold, striking flowers are frequently seen in modern decorative designs and lend themselves readily to decorative treatment.

#### DECORATIVE TREATMENT

##### 15. Some Examples of Decorative Treatment.

The designs executed by William Morris, Fig. 4, are characteristic of the peculiar decorative treatment that was strongly influenced by the Gothic style of architecture in England. It is based on the old Gothic tapestry and mural

THE NEW YORK  
PUBLIC LIBRARY  
ASTOR LENOX  
TILDEN FOUNDATION







ASTEC LENOX  
THE LENOX COMPANY

decorations, and severely conventionalizes the forms that it borrows without servilely imitating nature. In Fig. 9 and also in Figs. 11 to 13, however, are shown some modern designs based on the so-called L'Art Nouveau, which, as said



FIG. 11

before, has undoubtedly been influenced by the study of Japanese art. One can see that, although these ideas are borrowed from nature, nothing has been directly copied. Invention has been employed to give a fanciful effect. In Figs. 9

and 11 noticeable features are introduced into the decorative marking of both the leaves and the flowers, regardless of light or shade, in order to give effect. The growth has been



FIG. 12

arbitrarily arranged and many examples of L'Art Nouveau are extremely sinuous. Note how cleverly the different forms are grouped—the flowers, stems, and leaves are arranged in masses, showing much thought and skill. In this we find

what is distinctly a composition and not an attempt to throw bunches of flowers together at haphazard, as is characteristic of many naturalistic renderings.



FIG. 13

Where an all-over pattern is desired, as in Fig. 9, note that it is obtained by a clever manipulation of the forms, the main lines being bent and twisted to fill in and balance the space they will occupy. This fanciful, free, and apparently

simple treatment of plant forms can be secured only after a long, close study of nature and the handling of forms. Where one is thoroughly familiar with a plant, he can arrange it as he chooses, but his decorative sense must direct him regarding what points to emphasize in order to bring out the character and enhance the interest.

The student should frequently plan for himself exercises in this line of work. For instance, taking a nasturtium, the growing plant if possible, he should arrange it within a given space, such as a diamond or lozenge shape, 12 inches high by 6 inches wide, grouping the stems and leaves and blossoms as suggested by the manner of growth. The stem lines should be sketched in first and the flowers and leaves arranged on them to form interesting groupings. If attempts to acquire the spirit expressed in L'Art Nouveau should be made, it will be obtained in a short time. Note that the nasturtium stems are full of virile curves and may be effectually arranged in harmonious groups; avoid the extremes of making them look like a tangle of snakes or a mass of worms. Harmonious lines need not necessarily be parallel; they may radiate, be in contrast, or irregularly cross one another.

The same theory of the pleasing groupings of lines in stripes or in checks applies to the grouping of stem lines in a design. Monotony must be avoided by judicious variation in the spacing of sets of parallel or nearly parallel lines.

Space may be filled fully or partially by the unit of the design. If a few flowers are used, they should be used to balance well in the allotted space. By balancing, we do not necessarily mean that they should be symmetrical. It is far better that the arrangements should not be alike on both sides of a center line, as in Fig. 12. The rendering of the design should be of the simplest character, light and shade being totally ignored, but the form, the characteristic marking and veining should be emphasized and made the strongest element of the design.

The lozenge form most readily permits of broad groupings, particularly the forms near the center and the departing

of the detail toward the ends. Units of this character should be composed in variously proportioned spaces; square, oblong, circular, elliptical, triangular, etc., as well as in spaces that have no given geometrical form. The student should make a number of arrangements of various plants in the manner described above and should be ever on the alert to catch suggestions from, and see decorative possibilities in, every growing thing. He should also study designs that he finds about him and endeavor to analyze their principle of construction and put himself through the same problem that the designer before him did in exercising them.

#### CONVENTIONALIZATION

**16. Space Filling.**—For further exercise, the student should construct symmetrical figures suggested by the form of some simple flower, such as the common daisy, the oxeye daisy, dandelion, rose, or any convenient vegetable form.

In Figs. 14 and 15 are shown sixteen conventional designs based on the common daisy. Each of these is the work of a different student working on the same problem. Symmetry and balance are evident. The subject of this problem was the same in each case, and the different forms herewith shown are simple examples of the variety of solutions that can be arrived at in a single problem design when worked out by different individuals. Observe the variety in the treatment of different parts in the form of the ornament as a whole. Each form can be considered as a unit for repetition in the complete design, and these varieties show the opportunities for the almost endless chain of design based on a single flower or type. In considering any one of these balances as a unit in the design, due consideration should be given to the character and form of the space that is to be occupied, and for practice work it is wise to make repeated conventionalized forms of the same flower, basing them on some definite geometrical shape that the design is to fill. For instance, we have an equilateral triangle, the lozenge shape composed of two equilateral

triangles, the square, and the rectangle, each of which is frequently used in designs as a basis on which the repeat is arranged.

In filling these spaces, the designer must possess inventive genius; he must be original, independent, and daring, and he must be a close student of nature in order to combine these traits successfully in a given design. A man that happens to be possessed with instinct of design, but does not possess a thorough knowledge of nature, can hope to produce nothing more than an incongruous and irrational design; on the other hand, a man that is well acquainted with the details of nature, that has been a student of nature and is sufficiently daring and independent to depart from nature for good decorative reasons, is almost certain to be successful as a designer.

**17. Portraiture Not Aimed At.**—Suppose that one has a particularly difficult form to adapt in order to fill the proper space. It must be bent or twisted or curtailed until it fits. The problem here is to fit the space. The weak designer declines to bend his type because it does not bend in nature, or he declines to curtail it because it is natural that it should be extended, and the result is his decoration is sacrificed to his nature knowledge and the design becomes weak and lacking in decorative expression.

This gives some idea of the degree to which we may depart from portraiture of nature when we enter into the purely conventional treatment. The designer should make up his mind that so long as his designs do not overstep the bounds of good ornament and enter the realm of absurd and incongruous decoration, his fancy for decorative element may be as extreme as he chooses to make it. Therefore, one's imagination should be given free rein, and he should borrow his elements for their beauty and distort them, if necessary, to study them to his purpose, so long as he does not produce absurdities. The common swamp flag or the cattail grows perpendicularly; we never see them curved gracefully in nature and their only departure from the vertical



FIG. 14



is where the reed or leaf becomes broken. But if this type is desired as a decorative element to fit the space, we can bend the cattail or curve its leaves gracefully or arrange them as though unrelated to the ogee curve, so long as they suit the purpose and space for which they are intended. But to have them growing horizontally from the sides of the surface or diagonally out of the corners, or from the top downwards, would be to overstep the bounds of conventionalism and therefore would be an absurdity.

**18. Conventional Units.**—It should be borne in mind that the conventional units that we have at our disposal are the bilateral, the rosette, and the scroll. In the first, the design is symmetrical each side of the vertical line; in the second, it radiates in all directions from a central spot; and in the last, it evolves from a center. In the application of our previous suggestion, the cattail could not, with reason, be designed as a rosette, nor as a scroll; therefore, it must be based on some bilateral arrangement. Therefore, the designer should content himself with these simple units and not endeavor to break away from them and establish new ones, but accept the limitations and make the most of the type at his disposal. These forms are fixed, and variety is gained by giving freshness to the detail and interest to the handling.

This principle of ringing changes with a few simple forms is not confined to the subject of design. We find in the greatest dramas numerous plots based on familiar household tales and historic facts that never lack interest and originality.

The student should endeavor to picture his design mentally before any effort is made to place it on paper. He should see the form as a whole and roughly sketch it symmetrically on both sides of the vertical line. With the main lines in place, he may work up the details somewhat, and when thoroughly satisfied with this he should draw the whole and structural lines very carefully in on the left side of the vertical line, after which the drawing on the right side of the line may be erased



A piece of tracing paper is then laid over the left side of the figure, a vertical line drawn down the center and the whole carefully traced by means of a finely pointed soft-lead pencil. The paper should then be turned over and the lead lines transmitted to the right side of the figure by gently rubbing on the back of the paper with the forefinger nail. The right side can then be penciled in carefully and the whole drawing cleaned up and finished. With more skill in drawing one can draw both sides, freehand, securing the balance by means of eye measurement or scaling by compasses. The tracing method is the practical one because it is quicker as a rule, but it should not be resorted to on all occasions as it is good practice to duplicate two sides of the drawing entirely freehand. Symmetrical figures, the two sides of which are drawn freehand, are freed from mechanical inaccuracies and therefore are somewhat enhanced in value, and the best designs that are built on the symmetrical vertical always show a slight variation between the two sides indicative of the fact that they have been made freehand.

#### **19. Use of the Repeating Glass and Other Aids.**

In studying the effect of symmetry, a small strip of mirror or looking glass is useful. When laid along the edge of the design at an angle of  $90^\circ$ , it will enable the designer to study the effect of two sides of the design when completed. Two such strips of glass, whose ends come together, can be laid over a design, or the portion of a design, and a continuous circular design repeat obtained so as to convert any article or series of articles into a decorative rosette.

When the figure is carefully outlined it should be washed in with color or distemper, either in black and white or in some simple tints of body color, the best results being obtained by the beginner, however, by simply using several shades of gray.

It is a well-known fact that certain seasons or periods lean particularly to some historic style. Certain designers also show a decided inclination to work in a certain historic style, and likewise the student will find himself particularly inclined



(a)



(d)



(b)



(e)



(c)



(f)

to follow out a certain character of designing that either corresponds to a historical style or is characteristic of himself. The relation of this personal characteristic to a historic form may be entirely arbitrary and it may be due to the fondness of the student for that particular style of art. When one is working intentionally to obtain a historic effect, the spirit of the period represented should ever be borne in mind, no matter what may be the type from which the design is conventionalized. Although the Mohammedan religion forbids the representation of any living form, there is no reason why a modern Moorish designer should not draw his idea from any natural form. The character of the construction of the ornament and the handling of the color will determine the Moorish feeling, whereas the originality of the design may depend entirely on the ingenuity of the designer to apply some modern form to the historic Moorish construction. In a similar manner, modern floral fruit and vegetable forms can be applied to any style of historic ornament, if the student bears in mind the character of the style and endeavors to work in sympathy with it.

In Figs. 16 and 17 are shown several examples of conventional work executed by students of the Industrial Art School of Philadelphia. (*b*) and (*k*) are very barbaric in style, whereas (*e*) and (*j*) are strongly Romanesque in character. The fact that (*b*) and (*k*) are barbaric does not count against them, and the student whose work might be so classed should not feel discouraged, as it is far better that his designs be classed under the barbaric styles than to have them unclassifiable at all. As long as he possesses the fertility of invention, and continues the practice of conventionalization, he will overcome the limitation of his skill and be certain to show gratifying improvement.

Referring back to Figs. 16 and 17, one finds in (*h*) and (*i*) suggestive motives of L'Art Nouveau, while (*a*) and (*d*) are more Gothic in character, somewhat after the style of Morris. Exercises of this character should be practiced frequently; the circle, hexagon, triangle, and the lozenge shape being used as governing forms. The drawings should be about



(a)



(b)



(c)



(d)



(e)

FIG. 17

6 inches in diameter, or even more, and each should be carefully worked out in this practice work, as neatness and accuracy of execution can be acquired only by constantly practicing it in daily exercises.

Finally, the student of plant analysis should endeavor to become possessed of the knowledge of plant forms and methods of growth so that he can at any time not only sketch them from memory, but accommodate them to any form of surface or character of material. In making plant forms for practical design, the designer must bear in mind the material in which the design is to be executed and not design for stone carving that which is best suited for relief in wood, or design for carpet that which can better be reproduced as wallpaper. Every material and every method of manufacture has its limitations, and it is to adapt the natural forms to the limitations of these methods of reproduction that the designer must resort to conventionalism.

# DISTEMPER COLOR

---

## CLASSES OF COLOR

**1. Distinction Between Transparent Water Color and Distemper Color.**—Designs for furniture, interior decorations, and carpets, or for wallpaper and other printed fabrics, are usually rendered in water color, but water-color paints may be divided into two classes; namely, the transparent and the opaque. The *transparent water colors* are supplied in small cakes or pans, and simply require moistening to be made ready for use. They may be regarded, as a rule, as simply a series of stains that are spread on a surface to give it color without destroying the characteristics of that surface in any way. *Opaque water color*, usually called *tempera* or *distemper*, consists of an opaque pigment that, when spread over a surface, destroys all the characteristics, or markings, and leaves, when dry, a color or tone characteristic of the paint itself.

Wallpaper is printed in distemper, and consequently wallpaper designs are executed in this medium. Oilcloth, however, is printed in oil paint, but the designs are usually made in distemper, as it dries quickly and is easier to handle than oil paint. Designs for textiles and printed fabrics are made in distemper for the reason that it is easy to handle and at the same time, being opaque, covers, to a certain extent, the guide lines of the point paper on which it is laid and leaves the finished design similar in appearance to the finished fabric. That is to say, that in laying out a design for a carpet one uses cross-section, or point, paper, and must consider each line of squares on the paper as representing a line of warp or weft in the finished fabric. By laying out

*For notice of copyright, see page immediately following the title page*



the design with this consideration in mind, in distemper, the designer obliterates all the guide lines and his finished design appears as the finished fabric.

Designs for jewelry and enamel work are occasionally executed in oil color, although both water color and distemper are sometimes used. Designs for stained-glass windows, china decoration, and other ceramics are most easily rendered in transparent water color.

**2. Medium to Be Used in Specific Cases.**—Every designer, no matter what line of work he selects, should be able to execute his designs readily in the medium best suited to the purpose. To some purposes distemper lends itself very readily, while in other cases transparent water color is superior. In making designs for stained-glass windows and other ceramics, it is necessary that the color should be transparent, as the mineral paints with which the final fabric will be executed or painted must be transparent to show the texture of the material. Designs for silverware and certain forms of jewelry are sometimes executed in transparent color, particularly where the design includes some form of glass or enamel.

When a designer lays out a design for any given article or utensil, he is at liberty to use any medium for the purpose. Pencil drawings, pen-and-ink renderings, water-color or monotint washes, distemper or oil, are at his disposal, and there are no hard and set rules that necessitate his using any one of these mediums at any time. His judgment must be keen, however, and he must determine at the outset which medium is best suited for the purpose; for, should he represent in monotint that which could be better expressed in color, or should he represent in water color something that could be more suitably rendered in distemper, his design is likely to be misjudged and fail in its mission.

**3. Submitted Sketch Should Represent Finished Object.**—One point that the designer should thoroughly comprehend is that in preparing a design for a special purpose, it very seldom occurs that the design submitted to

the prospective purchaser resembles in any way the practical design or working drawing that is given to the craftsman by which he is to manufacture the article.

Should a designer be called on to present a sketch for a silver vase, he will probably find that the prospective purchaser expects to see a picture of the vase very much as it will appear when completed; he should, therefore, as far as possible, make his sketch a finished picture. However, when his design has been accepted and he turns it over to the silversmith to work into a reality he must not present to him a picture, unless he intends to leave it to the silversmith to work out the details. The working drawings must give accurate representations of the sections and repoussé work, in order that they may be suitably executed in accordance with the original intentions.

A design for a chair or piece of furniture should represent, in form and texture, the character of the finished work as it comes from the manufacturer's hands; and on a private order the prospective purchaser expects to be able, from the sketch, to determine the kind of wood, the color and style of upholstery covering, and the general appearance and style of the chair. However, when the design is accepted, the designer makes a working drawing, which goes into the shop, that shows simply how the article shall be put together, what precaution shall be taken to secure strength, how deep the carving shall be cut, if there be such, and in what direction the grain shall run in those pieces where there may be some uncertainty. It will be seen from this that a design for any object must necessarily be made in two forms, or possibly rendered in two mediums.

In order to represent all the conditions of wood grain, upholstery, etc. in the chair, one may use transparent water color to get a proper effect; whereas, a working drawing can be rendered simply in pencil and on brown paper, not only because such paper is much less expensive, but also because it is much more durable and better suited for shop handling.

The same fact is true of the silver vase, the original design for which may be rendered in water color, distemper,

or oil and submitted on a fine quality of drawing paper or canvas in order that it may make the best impression on the person that has ordered it, and it need not necessarily be more than one-quarter to one-half its actual size; as it will thus appear in detail as if observed in reality from a certain distance. The working drawing turned over to the silversmith need not present any of these artistic details, but must be rendered so as to give exact dimensions, accurate sections, and absolute form. These drawings, like those for the chair, can be drawn on coarse paper and in pencil only.

**4. Handling Color.**—Transparent water color is very easily handled where plain washes are required, but one must determine at the outset what color he will use, for having once laid a wash over a given surface the power to change it is very limited. With distemper, however, the case is different; the color being opaque, can be changed almost unlimitedly, for after it is dry it can be scraped off and another color laid in its place, or the second color can be laid over the first in some instances without the slightest difficulty.

**5. Colors Most Needed.**—A convenient lot of colors to use are the following: Turkey red, chrome yellow, ultramarine blue, chrome green, burnt sienna, raw umber, burnt umber, cremnitz white, and yellow ocher. It is wise to have, in addition to this combination of colors, a quantity of Antwerp blue and carmine in powder form, so as to vary the hue of the foregoing colors by admixture. Most of the distemper colors used by designers are put up in small glass jars.

**6. Grinding Colors.**—In their raw state these colors are usually insufficiently ground, and having no size mixed with them possess no adhesive quality. Therefore, if applied in design they will, when dry, brush off like so much powdered chalk. It is therefore necessary that they be reground, when needed, by means of a muller and a ground-glass slab. During the grinding process a little gum arabic is added to the paint and thoroughly ground up with it in order to give it the necessary sizing and adhesive quality. During the operation,

it is convenient to have a small sponge and a palette knife, so that the ground color may be scraped up with the latter and deposited in the ointment pots or small dishes that are used to hold the finished color, while the former may be used to squeeze a few drops of water occasionally as more paste or powder is added to be ground.

NOTE.—The colors furnished with the I. C. S. outfits are ground ready for use.

In grinding the color, it is quite important to get a sufficient amount of size mixed with it to make it adhere properly to the surface to which it is applied, and to get no more than is sufficient. Too little will cause the color to blur and brush off, and too much will make it sticky and very difficult to manipulate.

One way to determine this is by testing. A certain quantity of color may be mixed under the muller and ground with gum arabic. Experiments should then be tried with it to see whether it flows properly and adheres satisfactorily. A small space may be painted on a small piece of paper and permitted to dry while the grinding proceeds, or if the paint is sufficiently ground it may be quickly dried by heat. When thoroughly dry it should remain fixed, even when rubbed briskly with the dry finger or a soft eraser; but if it appears shiny when dry, too much gum arabic has been mixed with it, and more color should be ground in, in order to reduce the proportionate amount of size.

Colors ground with an insufficient quantity of gum dry absolutely flat and without streaks, and beginners are likely to be misled with the pleasing appearance presented under these conditions; while too much gum causes the color to dry in streaks and to scale off and crack. Therefore, frequent experiments in artificial drying should be tried, in order to get satisfactory results.

Different colors require different amounts of size. Dark colors, such as ultramarine blue, require more size than the lighter colors, such as chrome yellow and white; therefore, no rule can be laid down as to the exact amount of size that is necessary.

The grinding should be accomplished by a slow, rotary motion of the muller, grasping it as illustrated in Fig. 1. The more carefully the color is ground, the more easily can it be manipulated with the brush. It must be perfectly



FIG. 1

smooth and free from lumps or grit, and with a little experience one can learn to judge of its condition by the way it feels under the muller or in the brush when applied, although at first the designer should always test it and permit it to dry. Powdered colors require moistening before they are ground.

**7. Preserving the Ground Colors.**—After the color is ground it should be put away in jars with screw caps, and if too thin for use the jars may be left open until the moisture has evaporated and the color is of the consistency of a thick paste. If the colors become entirely dry, however, they must be removed from the jars and *reground with water*. This can be done immediately before using, as after they have been once ground the second grinding will be a very short operation.

The greatest care should always be exercised to keep the colors clean, and where a mixture of two or more colors is required the brush should not be dipped into the jar. A certain amount of color should be removed from the jar to the ground-glass slab and mixed with whatever other color is desired, stirring with the palette knife until they are thoroughly united.

In removing the colors from the jars, either for direct application to a design or for mixing with other colors, it is always well to stir them thoroughly, as the size is likely to settle at the bottom.

**8. Making a Color Chart.**—The student, after reducing his colors to the proper consistency, should lay out Color Chart A, similar to Fig. 2. First, the six colors should be spread on six squares measuring 1 inch each, as shown on the left side of the diagram at (*a*) in the order indicated; namely, commencing at the top with turkey red, then chrome yellow, ultramarine blue, raw sienna, burnt sienna, and burnt umber. In column (*b*), a series of five squares should each be covered with a mixture of turkey red with each of the other five colors, commencing with yellow. In column (*c*), four squares should be drawn showing mixtures of yellow with each of the four colors beneath it; and in column (*d*), three squares showing a mixture of blue with each of the three colors beneath it. In column (*e*), each of the colors in column (*a*) is mixed with a quantity of black, which dulls the tone; while in column (*f*), each of the colors in column (*a*) is mixed with white, which lightens the tone and converts the colors into mere tints. This chart should be drawn on a good quality of Whatman's paper or cardboard,  $7\frac{1}{2}$  inches by 10 inches. The squares are  $\frac{1}{2}$  inch apart horizontally,  $\frac{5}{8}$  inch apart vertically. When finished, this chart should be preserved and sent in to the Schools for criticism and suggestion, as directed hereafter.

In using the mixed distemper color for a design, a sufficient quantity should be taken with the palette knife to about half fill an ointment pot; this should be placed in the center

of the ground-glass slab, with a small quantity of gum arabic in solution. The gum-arabic solution should be as thick as it can possibly be made, for if it is too watery the paint will spread out on the slab while grinding and require constant attention to keep it under the muller. Certain colors are more troublesome in this respect than others, particularly white, chrome yellow, black, and raw sienna; but if the jars containing these colors are allowed to stand open for a time the pigment will thicken, and this difficulty can be obviated to a certain extent. In opening a jar of color, any free water that is found on the surface should be poured off before taking out the paint to grind.

**9. Applying Distemper Colors.**—Distemper colors are all opaque and have considerable body; therefore, they cannot be washed over a square in the same manner that transparent water color can, but are laid like oil paint. When dry, it is highly desirable that they present a perfectly smooth, dull surface, without indications of brush marks.

The prepared color should be applied with ordinary water-color brushes, preferably sable brushes, as they are exceedingly elastic and come readily to a point. Red sable brushes, Nos. 6 and 7, are a necessity for wallpaper and carpet designing, but for the latter purpose the sharp points should be burned off by touching them to a hot iron. Care should be taken that the end be burned perfectly square and of the proper width or bluntness to fit the checks in the design paper. For very large surfaces, such as background tints in wallpaper designing, the sponge may be used, or a large camel's-hair brush. In fact, the designer should learn early in his efforts to exercise his ingenuity and take advantage of every medium he possibly can to secure the desired effects, or to save time in laying in his work.

When the color is mixed to about the consistency of cream and painted over a surface with reasonable rapidity, it will usually dry perfectly flat without indications as to what direction the strokes of the brush were used to make it. It occasionally appears somewhat streaked in drying, but it



FIG. 2. COLOR CHART A



THE NEW YORK  
PUBLIC LIBRARY  
ASTOR LENOX  
TILDEN FOUNDATION

will dry out very satisfactorily if it has been mixed to the proper consistency.

In case of error, the color can usually be washed or scraped off, the former method being advisable where there is any considerable quantity. To wash it off, a small sponge should be wetted with clean water and the whole surface of the paint moistened; then, by rubbing from the edge of the paint toward the middle, on all sides, the color can be washed up into a central puddle, taken up with a palette knife, and at last taken out entirely. In doing this, rinse the sponge frequently, so that it will not soil the paper as it passes over it.

Care should be taken in handling distemper, to see that it is evenly worked up to the edges of the surface it is to cover, and frequent practice on smaller squares than these is desirable, as in designing for textile fabrics the squares on the design paper are sometimes as small as  $\frac{1}{16}$  inch. To evenly work up the edge of small squares, it is sometimes desirable that a small but firm, broad stroke be passed around the sides of the square to define the edges, and that the center be then washed over and filled in. Where the space is large or complicated, it is better that the color should be carried along the edges and over the surface at one time in precisely the same way that a wash would be applied.

---

### COLOR MATCHING

**10. Good Color Sense a Necessity.**—The designer should always be able to match color accurately, for he is frequently called on to execute designs that call for the use of materials or fabrics having certain colors. Many persons have color perception developed to a greater degree than others, while a few persons possess no color perception whatever, and are said to be **color blind**. Color blindness is a very serious drawback to a designer and prevents his working, except in a very limited field. However, considerable practice is required to train the perceptive faculties of a person with normal eyesight so that he can readily detect what colors or shades or tones exist in a certain fabric before him.

In Fig. 3, Color Chart B, is shown a chart of color matching; its dimensions are the same as the other chart— $7\frac{1}{2}$  inches by 10 inches. The exercise consists in matching the color of five pieces of material of varying hues and textures.

The student should obtain some colored goods, such as woolens, cottons, silks, velvets, etc., and endeavor to mix colors to match them exactly, making selections of at least five different colors and pinning them to a paper, as shown in Color Chart B; then draw beside them a square representing the color. This will necessitate frequent testing of the color on a separate piece of paper, and the addition thereto of other color until the required shade is attained. One must learn to see whether the color applied to these individual squares requires more blue, more yellow, or more red. In selecting the colored goods to match in this exercise, it is best to select such as possess colors that combine agreeably and at the same time make as great a variety of color as possible.

The desired mixture should be made with as few colors as possible, and when the proper tint is painted on a separate piece of paper and allowed to dry one can readily judge whether it is too light or too dark, too intense or too neutral, or whether it leans too much or too little to some decided color. As it is very much easier to lighten a tone than to make it darker, it is always best to err on the safe side and start in with a color that is somewhat darker than the one to be matched, and to gradually lighten and decrease its intensity by adding some of the lighter colors with which it is to be mixed, or by adding white, as the case may require.

For instance, if the color to be matched is a blue-violet, start with ultramarine blue and a little carmine until the required color is obtained, and add to this a sufficient quantity of white until the proper tint is reached. If only a small amount is needed, the white may be added to the pure color before it is mixed.

**11. Ways of Changing the Hue or Tone.**—The addition of white to any color not only lightens it but

# COLOR MATCHING



8 56

FIG. 3. COLOR CHART B

T 1111  
P 1111  
1111  
1111

changes its hue somewhat, making it colder or bluish; this can be counteracted by the addition of a little yellow or other warm color. It will also be noticed that the addition of white or black diminishes the intensity of a color. This is occasionally annoying when one needs a very light or dark, but still very intense color to match, and the combination of colors will not produce it with the addition of the black or white pigment. When the nature of the color to be matched permits it, a dark color can be heightened by the addition of some lighter color instead of white; and a light color may be modified by a darker one, where not far removed from itself in point of hue, instead of mixing it with black.

Thus, burnt umber may be heightened by the addition of chrome yellow, and burnt sienna with chrome yellow and turkey red, without losing any of their intensity. Chrome yellow may be reduced with brown or burnt sienna, or by the addition of both red and blue, instead of mixing it with black.

Where it is desired to mix a bright green with either yellow or blue in order to change its hue, it is best to use Antwerp blue, as this has a tendency toward green, and not to use the ultramarine, which has a tendency toward purple. Ultramarine blue, however, is the best to use for violet, and when mixed with turkey red or carmine makes a rich color. Turkey red mixed with yellow makes a better orange than carmine and yellow; and so, the designer will learn from time to time that certain combinations of similar colors produce entirely different results.

**12.** Considerable practical experience is necessary to enable the designer to judge the amount of color necessary to prepare in any case, and the beginner usually wastes much material in this way, until his judgment is well trained. In mixing color to go over a certain space, it is always better to have too much than too little, as it is a tiresome and tedious job to have to match color, as is the case where one stops to mix more color because the supply has become exhausted.

Shiny stuffs, such as satins and silks, that show light and shade are more difficult to match than dull goods. In matching colors in such goods, they should be held in a very strong light and the general color effect studied with the eyes partly closed.

**13. Effects of Artificial Light on Colors.**—Colors can never be matched satisfactorily by artificial light, and it should be taken into consideration at all times in preparing a design that although it may be designed and manufactured by daylight it is likely to be seen in the finished fabric by gaslight or lamplight, under which circumstances its color values might be materially changed. Lamplight or gaslight varies from yellow to orange-yellow, and viewed under these conditions, colored designs will present exactly the same appearance as though their colors had been mixed with yellow-orange before they were applied to the paper. The yellows in the design become scarcely visible, and red and orange become materially heightened under the influence of the yellow light. The cold reds tending to purple lose their purplish hues, and the pure blues and those tending to violet become much more violet. The greenish blues, such as Antwerp blue, become still greener and blue violet is very much dulled in hue, while red violet becomes slightly redder.

The yellows and blues seem to suffer most under yellow artificial light, as the yellow becomes entirely canceled or absorbed by a light of its own color, and the blue is largely neutralized by a light that is complementary to its hue. Therefore, one can see that it is practically impossible to match colors by artificial light.

### COLOR HARMONY

**14. Advantage of a Good Color Scheme.**—It is of vast importance that the designer be able to work out a satisfactory color scheme in any of his designs, even though the manufacturer reserves the privilege of changing this color scheme to suit his own requirements. A good color scheme gives much personal satisfaction to the designer. It makes a good impression on the manufacturer to whom the design is submitted, and, consequently, may assist in its sale. No matter how satisfactory the original color scheme may be, the product will usually be reproduced with a number of color arrangements that are dictated by the experience of the color man in the factory.

The manufacturer's facilities for obtaining a variety of color schemes quickly are much greater than those of the designer. The wallpaper manufacturer can order his operator to touch his printing block to any particular slab of color, or to vary the color on that slab or in the troughs of his printing machine. Or, the textile manufacturer can load his frames or his shuttles with different colors of yarn and try the effect of a pattern under different conditions, whereas the designer must work out his color scheme mentally and laboriously paint it on his pattern. Therefore, it behooves the designer to select for his pattern such a color scheme as will show his design to the best advantage, as it is difficult for him to work out more than one.

The method of the manufacturer of trying different color schemes involves an element of chance that makes it very fascinating. It is not unlike looking into a kaleidoscope wherein we see an endless variety of geometrical effects, but occasionally strike a combination that is much more interesting in form and color than the others. Thus the manufacturer experiments until he finds the combination that suits him best.



### CLASSIFICATION

**15.** All schemes of color can be divided into five general classes; namely, bad, inoffensive, satisfactory, attractive, and commanding. A practical working system of color harmony—one that can be calculated mathematically to give the proper hues, tones, and quantities of various colors—has never been invented. Each designer is dependent on his own color perception to secure his harmonies.

**16. Sources of Color Inspiration.**—We have but three sources from which to draw all color inspiration. First, the scientific analysis of light, which is the source of all color, from which we get the spectrum; second, various combinations of color seen in nature; and third, the combinations of color that have been used throughout all ages in the best periods of decorative art and architecture. From these sources various rules have been deduced that give valuable aid in practical work. These rules not only help one to form intelligently and to judge his own color scheme, but they also give him the key to the solution of numerous different color schemes for the same subject and assist him to judge which one to select.

---

### SPECTRUM SCALES

**17. Preparing the Color Chart C, Spectrum Scales.** With this Section the student is furnished with a book of colored papers representing the eighteen colors in the spectrum scale with two tints and two shades of each color. These papers are to be used as hereinafter directed to prepare charts which will serve him in solving problems in *Color Harmony*, which charts he is to preserve for use throughout the study of this Section, and then send in for correction and criticism with his answers to the Examination Questions.

Designers deal almost exclusively with positive color, and for that reason a thorough, practical working knowledge of the spectrum scale is indispensable. The analysis of

white light gives us the purest scale of colors that can be studied, and the best way to study them is to make charts for one's personal use.

Color Chart C should consist of six spectrum hues with twelve intermediate hues, making eighteen hues. To prepare such a chart, take a piece of bristol board about

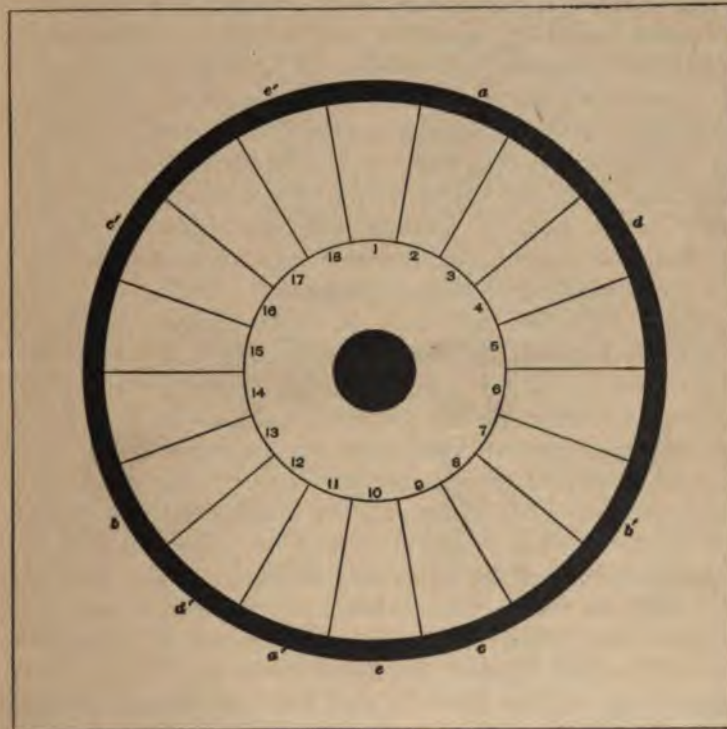

FIG. 4. COLOR CHART C

$7\frac{1}{2}$  inches by 10 inches and inscribe thereon a circle with a radius of  $3\frac{3}{8}$  inches. Divide this circle into eighteen equal parts, as shown in Fig. 4, and draw lines from the points of subdivision toward the center until they intersect with the circumference of a second circle whose radius is  $1\frac{5}{8}$  inches. Number these sections from 1 to 18, commencing with the one at the top, as shown in Fig. 4. From a piece of paper

cut a pattern representing one of the eighteen sections laid out on the cardboard. Now, from the book of colored papers, pieces should be cut to mount on the diagram so as to form a scale of spectrum colors in the order that they are used in the book, commencing with violet-red, which is pasted on section 18 and proceeding to the right to red on 1, orange-red on 2, red-orange on 3, orange, etc. throughout the scale, omitting the tints and shades. A black circle around the outside,  $\frac{1}{4}$  inch wide, and a small black circle in the center, 1 inch in diameter, will complete the diagram and render it suitable for use. Next, mark on the diagram the colors orange-red, blue, and yellow-green,  $a$ ,  $b$ , and  $c$ , and their complementary colors, blue-green, yellow, and violet,  $a'$ ,  $b'$ , and  $c'$ . Orange and green should now be marked  $d$  and  $e$ , and their complementary colors, green-blue and violet-red, respectively,  $d'$  and  $e'$ .

It will be noted that there is an insufficient number of gradations between the blue and green to furnish complementary colors for all the primary shades between the red and yellow, and that there are not enough shades between green and yellow to act as complements to those lying between blue and red; but the correct position of the six missing colors can be easily determined by looking on the opposite side of the chart in the proper position. For instance, the complementary of 1, which lies between  $e'$  and  $a$  at the top, must be some color between  $e$  and  $a'$  at the bottom of the chart; also, the complementary of 3, which lies between  $a$  and  $d$ , must be found between  $a'$  and  $d'$ . In making use of the chart in this way the student at once becomes conscious of what is known as *simultaneous contrast*.

**18.** *Simultaneous contrast* is that peculiar power of one color to affect its adjacent colors with a complementary hue. First, each section of colors appears to be more or less graded in tone, being apparently darker toward the edge that approaches a lighter color. Second, there is considerable gradation of hue between the two edges of each section; this phenomenon becomes more apparent the longer the chart is

TABLE I  
CONTRASTS OF COLORS

Color	Tinged With Complement of		Appearance
	Color	Composition of Color	
Red	Orange	Green-blue	Purplish
Orange	Red	Blue-green	Yellowish
Red	Yellow	Blue	Darker and purplish
Yellow	Red	Blue-green	Brighter, slightly greenish
Red	Blue	Yellow	Brighter and more orange
Blue	Red	Blue-green	Brighter and slightly greenish
Red	Blue	Green-red	More intense
Blue-green	Red	Blue-green	More intense
Red	Violet	Yellow-green	Brighter and more orange
Violet	Red	Blue-green	Bluish
Orange	Yellow	Blue	Duller and redder
Yellow	Orange	Green-blue	Lighter greenish
Orange	Green	Violet-red	Deeper orange
Green	Orange	Green-blue	Slightly bluish
Orange	Green	Blue-orange	More intense
Green-blue	Orange	Green-blue	More intense
Orange	Violet	Yellow-green	Lighter and yellowish
Violet	Orange	Green-blue	More bluish
Yellow	Green	Violet-red	Duller and more orange
Green	Yellow	Blue	More bluish
Yellow	Green	Blue-orange	Brighter and more orange
Green-blue	Yellow	Blue	Brighter and more blue
Yellow	Blue	Yellow	More brilliant
Blue	Yellow	Blue	More brilliant
Green	Blue	Yellow	Yellowish green
Blue	Green	Violet-red	More violet
Green	Violet	Yellow-green	More yellow
Violet	Green	Violet-red	Redder violet
Yellow-green	Violet	Yellow-green	More brilliant
Violet	Yellow	Green-violet	More brilliant
Blue	Violet	Yellow-green	Lighter, slightly greenish
Violet	Blue	Yellow	Red violet
Violet	Violet	Red-green	Duller and more blue
Violet-red	Violet	Yellow-green	Duller and more red

studied, and is particularly apparent in hues 12 and 13, which appear decidedly bluer on the lower side than on the upper, where they seem to approach a greenish hue.

From this law of simultaneous contrast we know that each color possesses the power of affecting its immediate surroundings with a slight touch of its complementary hue, which is lighter and much more intense than the pigments used to represent this complementary color. Thus, when blue and yellow are placed next to each other, the blue affects the yellow with a yellowish tinge that is much brighter and more intense than the yellow itself; and we have, in consequence, an increase both in light and saturation. The yellow, on the other hand, tinges the blue with a more intense blue, and a mutual increase in brilliancy is the result. When two colors close together in the scale, such as orange and yellow, are placed next to each other they tend to impoverish or reduce the intensity of each other. The reason for this is that the orange sends over to the yellow a tinge of greenish blue, which being nearly complementary to the yellow and acting in the manner of mixing the colored lights, tends to make the yellow paler and slightly greener, while the yellow sends over to the orange a tinge of blue that neutralizes the yellow in the orange and makes it appear duller and redder. These two examples give, perhaps, the extremes of good and bad effect, but Table I gives the changes due to simultaneous contrast when two colors are placed next to each other.

#### DIFFERENCE BETWEEN MIXING COLORED LIGHTS AND COLORED PIGMENTS

**19. Applications to Various Lines of Work.**—While mixtures of colored lights produce the same effect, to a certain degree, as the mixture of colored pigments, certain combinations are so much different in degree that the effect appears entirely different. Complementary pairs of colored lights, when combined, produce *white*, while complementary pairs of colored pigments produce a neutral gray, but **neutral**

gray can be considered the same as white under a low degree of illumination. There are exceptions to these conditions, however. In pigments, a mixture of blue and yellow produces green instead of gray, while in colored lights taken from the spectrum, a combination of blue and yellow produces white; a mixture of red and green pigment produces gray, but a combination of red and green light produces yellow.

These points are of special importance to the designer in all lines of work, but especially to the textile designer whose pattern is built up of various colored threads, or yarns, that are brought to the surface of his fabric in small dots or fine lines of color. These colors lying adjacent to one another obey the same laws of combination as do mixtures of colored lights but do not reach the same degree of brilliancy. Thus, a surface covered with alternate blue and yellow dots, where these colored threads come to the surface, would not appear green, as one might suppose, but a very light gray. It will therefore be well to bear in mind what these combinations present. Assuming that the ends are viewed in an average light, we find that alternate threads of red and yellow-green appear dull yellow; alternate threads of violet and yellow-green appear blue-gray; alternate threads of violet and yellow appear light red-violet, and alternate threads of red and blue appear light violet-red. In every case where the colors used for such a combination are complementaries of each other, or where they approach the complementary colors, the combination produces a gray varying with the tints of the complementaries combined. Thus, alternate threads of red and blue-green, of yellow-green and violet, and of yellow and blue appear neutral gray; as will also one thread of orange to three of green-blue, or one thread of green to two of violet-red.

#### 20. A Working Scale of Pure Spectrum Colors.

In Fig. 5 is shown a chart of spectrum scales presenting two tints and two shades of each of the eighteen hues. In Fig. 5 the positions for the tints are shown at  $T_1$  and  $T_2$ , while the shade rows are indicated at  $S_1$  and  $S_2$ , with the pure

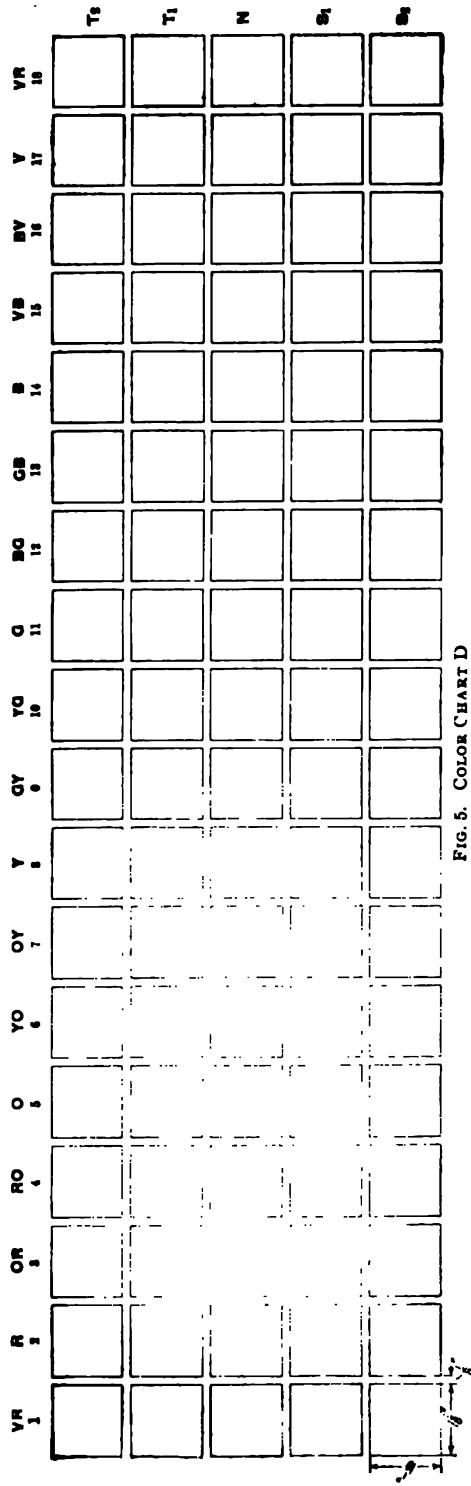

FIG. 5. COLOR CHART D

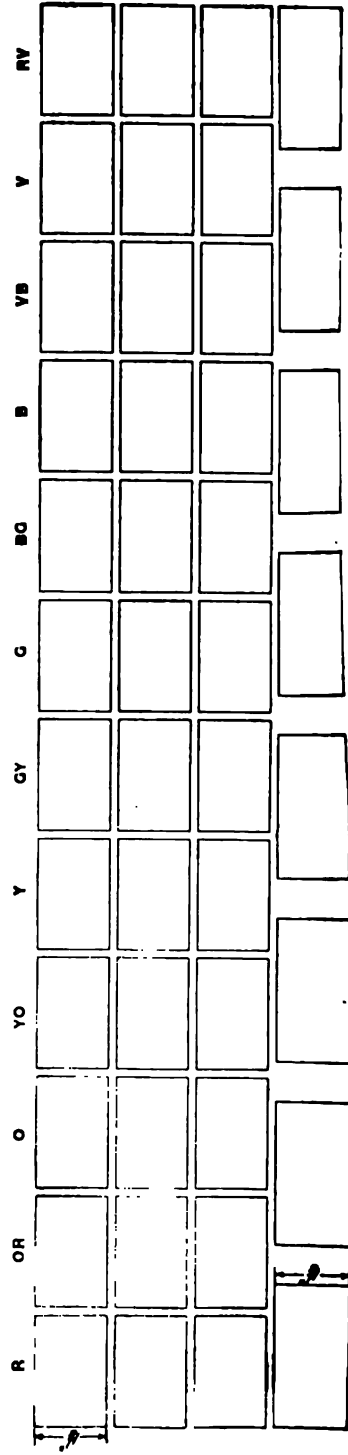

FIG. 6. COLOR CHART E

spectral colors at *N*, which stands for Normal. The tints are formed by the addition of white to the color, while the shades are formed by the addition of black. Such a chart as this should be possessed by each student in order that he may familiarize himself with the peculiarities of these color harmonies and color contrasts. In the center of a sheet of cardboard  $7\frac{1}{2}$  inches wide and 26 inches long, a space  $6\frac{1}{2}$  inches by  $22\frac{3}{8}$  inches should be marked off. The squares containing the colors are  $1\frac{1}{8}$  inches on the side and spaced  $\frac{1}{8}$  inch apart; they should be drawn in pencil. Here we have the eighteen scales of the spectrum, from violet-red at one end to red-violet at the other, and five tones in each scale, arranged vertically, the pure color occupying the center of each column with the two tints above and the two shades below. The colors are cut from the sheets of paper in the same order as they come in the color book, and after the squares are cut and mounted on the card they should be left under a weight until thoroughly dry. When thoroughly dry, cut the scale in three sections between orange and yellow-orange, and between green-blue and blue. After cutting, the pieces should be replaced and secured by means of a piece of tape as a hinge, so that the chart can be folded down to the standard size.

Such a scale as this makes an excellent working scale of colors that can be kept for reference purposes for an indefinite time, unless left exposed to strong light, which will tend to fade some of the colors, particularly the violet-red and green.

**21. A Working Scale of Broken Spectrum Colors.** In Fig. 6, Color Chart E, is shown a scale of *broken spectrum hues*. By *broken hues* we mean spectrum colors that are modified by the addition of both black and white. Such modification has the effect of graying the color or making it less intense by the addition of neutral gray. It will be borne in mind that a mixture of black and white produces a neutral gray, that the addition of white to the pure color reduces the color to a tint, while the addition of black produces a shade,



and the addition of black and white together produces a broken hue by the introduction of gray to the color.

In the color book are found three tones each of twelve of the broken spectrum hues. These should be arranged on a card  $7\frac{1}{8}$  inches by 26 inches, together with the eight grays, as shown in Fig. 6. The inner space containing the colors measures  $4\frac{7}{8}$  inches by  $19\frac{5}{8}$  inches and the colored slips are  $1\frac{1}{8}$  inches wide by  $1\frac{1}{2}$  inches long, with a space of  $\frac{1}{8}$  inch between them, except between orange and yellow-orange and between violet-blue and blue, where the space may be increased to  $\frac{1}{4}$  inch so that the chart may be cut and folded in the same manner as Color Chart D. The gray slips are 2 inches long by  $1\frac{1}{8}$  inches wide with  $\frac{1}{8}$  inch between them.

In working out a color scheme, these two charts may be used in conjunction, and the color arrangement of a special design may be effected by selections from each. The broken colors are far easier to combine harmoniously than the pure spectrum colors, but practice is necessary in order that one may become familiar with both scales, and the ability to intelligently combine them gives one the greatest freedom in polychromic design.

— — — —

#### CLASSIFICATION OF COLOR HARMONIES

**22.** To the textile worker and designer, a system of classification in color harmony is a matter of the greatest importance. Various authorities have endeavored to establish one that would embrace, under a limited number of heads, every possible combination. The object of this is to enable one person to communicate to another the exact shade of color referred to by means of a symbol or a name, so that samples of colors need not be furnished in each particular case in order to properly execute a given design.

A more comprehensive classification than most of these has been prepared by Henry T. Bailey; it includes all colors under the following five heads: **Contrasted, dominant, complementary, analogous, and perfected.**

1900

THE  
PUBLIC  
ACT  
TILG

Examples of  
Contrasted  
Dominant  
Complementary  
Analogous  
and  
Perfected  
Harmony





FIG. 9



FIG. 10



FIG. 11

1000

In *contrasted harmonies*, color is opposed to non-color; or active color is opposed to passive color, such as a spectrum color opposed to black, white, gray, silver, or gold. Fig. 7 illustrates contrasted harmony where it shows two tones of red contrasted with gray and white.

*Dominant harmony* is where different tones are combined in one color scale, as shown in Fig. 8. Combinations of this kind are termed self-color, as they consist of a variation of similar colors but of different tones. In this figure, six tones of yellow have been employed to produce this effect.

*Complementary harmonies* is where complementary colors are contrasted; that is to say, where orange is contrasted with blue, red with green, etc. In combinations of this character it is desirable that tones should be opposed to one another as well as colors or there is an unpleasant effect of movement in the color called *dancing*. Red and green possess this peculiarity to a very marked degree, particularly when the hues are actually equal in tone. Tints of one hue opposed to shades of the opposite will overcome this difficulty, and the introduction of several tones of the same color will tend to lessen it, as shown in Fig. 9, where two tones of blue outlined in green are contrasted with two tones of orange-yellow, thus forming a complementary harmony.

*Analogous harmony* is formed by combining tones of analogous colors; that is, colors that stand near one another in a spectrum scale, such as yellow, green-yellow, and orange-yellow, or blue, green-blue, and violet-blue. Such combinations are usually better when contrasted in tone, though the intervals should not be too great, and the effect may be seen in Fig. 10 where tones of broken green, green-yellow, and orange are employed with great softness of effect.

*Perfected harmony* is where analogous colors are combined with the complementary of the *key color*—by key color we mean the color that they possess in common. For example, orange-yellow and yellow-green are combined in contrast with blue—blue being the complementary of the key color; yellow is common to both the other colors, as shown in Fig. 11. Perfected harmony exists also in combinations

where two sets of analogous colors are complementary to each other. It is a complementary harmony of much greater latitude as it takes in colors on either side of the opposing pairs; for instance, the group surrounding yellow is opposed to the group surrounding blue.

By this system of classification of color harmonies, the student is not possessed of the mere mechanical means for the formation of the best color combinations, but rather is given a suggestion as to what constitutes a safe combination of colors in the direction of harmony.

Knowledge of this character is of the utmost importance to the student as he uses positive color for the first time, as it gives him a firm understanding by which he may proceed and prevents wild and erratic attempts to produce effects without knowing the reason or the theory. It is an acknowledged fact that some persons seem to be possessed naturally with a color sense so that they can make good combinations and satisfactory harmonies without any apparent effort, while others of apparently equal intelligence seem utterly helpless when confronted with the color problem, and if left to themselves frequently make the most inharmonious combinations without apparently being able in any way to avoid this bad practice.

**23.** Students of color harmony should make several schemes of color, illustrating the five classes of color harmony. Probably the most useful exercise is the attempt to classify, under each of the different heads above set forth, such color combinations as are observed in nature and in applied color. Color Chart D of spectrum scales, together with Color Chart E, presents an almost inexhaustible source of color schemes.

First, the five tones in the scale of any hue furnish satisfactory dominant harmonies or self-color combinations, and these tones can be extended unlimitedly by the admixture of black or white.

Second, the block of fifteen tones formed by fifteen consecutive columns furnishes excellent material for analogous

harmonies. But it is by no means necessary that one should confine himself strictly within the limits set forth, as further variations of light and shade are always permissible by the good judgment of the student. In combining colors that are closely related to each other, it is a good rule to bear in mind that it is bad practice to combine a shade of a bright color with a tint of a dark color, as this destroys the characteristics of the two colors. Such combinations should be so graded that the bright color will always be the lighter and the dark color the darker of the two. For instance, dark shades of orange with pale tints of red, or shades of yellow with tints of green, make a very bad combination.

Third, the scales of the pairs of colors, numbers 1 and 11, 3 and 12, 5 and 13, 8 and 14, and 10 and 17, when combined, form complementary harmonies. In employing combinations of this character it must be borne well in mind that they always involve a contrast of the warm and cold colors, as the colors from 1 to 10 are warm and those from 11 to 18 are cold. The warm colors advance and make themselves conspicuous, while the cold colors are retiring and tend to withdraw toward shadows. The latter effect is more strongly marked where combinations of colors between 3 and 8 are effected with those from 12 to 16. Where a design is executed in a reddish orange on a blue background, it will stand out and appear to detach itself from the ground and give forwards an effect that is particularly noticeable in designs for stained glass, where the lead lines increase the effect of difference in plane between the two colors. This is an exceedingly important point in the consideration of backgrounds; for, as a rule, dark cold colors make satisfactory backgrounds for patterns in warm hues, and dark warm colors are satisfactory as backgrounds when the pattern is in light cold hues. But if the intensity of the background and the pattern is about equal, the warmer colors advance and the cold colors retire. The greens found at *d*, *a'*, *e*, and *c*, in Color Chart C, and their complementaries *d*, *a*, *e'*, and *c'* are the most difficult to manage of any pairs. Their contrasts are hard if used full strength,



but are satisfactory when reduced to shades, tints, or broken colors. Blue and yellow make a brilliant combination and are used more extensively than any other colors in decorative design. Next to these, in point of general use, we find the green-blue contrasted with orange and then violet

TABLE II  
COMBINED PAIRS OF SPECTRUM HUES

Hue	Combined With	Effect	Hue	Combined With	Effect
2	1 or 3	good	7	12 or 13	fairly good
2	4, 5, 6, or 7	bad	7	14 or 15	very good
2	8, 9, or 10	moderate	7	16 or 17	good
2	11	{powerful but harsh	7	18 or 1	fairly good
2	12 or 13	fair	7	2, 3, 4, or 5	bad
2	14 or 15	very good	8	7 or 9	good
2	16, 17, or 18	bad	8	10, 11, or 12	bad
3	2 or 4	good	8	13	moderate
3	5, 6, or 7	bad	8	{14, 15, 16, or 17	very good
3	8, 9, or 10	moderate	8	18	good
3	11 or 12	{powerful but harsh	8	1, 2, or 3	moderate
3	13, 14, or 15	very good	8	4, 5, or 6	bad
3	16	moderate	10	9 or 11	good
3	17, 18, or 1	bad	10	12	fair
5	4 or 6	good	10	13	not good
5	7, 8, or 9	bad	10	14, 15, or 16	good
5	10 or 11	fairly good	10	17, 18, or 1	very good
5	12, 13, or 14	{very good (powerful)	10	2, 3, or 4	moderate
5	15, 16, or 17	fairly good	10	5, 6, 7, or 8	bad
5	18	moderate	11	10 or 12	good
5	1, 2, or 3	bad	11	13, 14, or 15	bad
7	6 or 8	good	11	16, 17, or 18	moderate
7	9, 10, or 11	bad	11	1, 2, or 3	harsh
			11	4, 5, 6, or 8	fair
			11	7 or 9	bad

contrasted with greenish yellow. As a general rule, true complementaries make a better appearance than colors only approximately so, but modifications in the tone of a color make no difference in its relation to its complementary color. Thus, any tone in the yellow scale is complementary to any tone in the blue scale.

Fourth, a selection of hues from any block of fifteen tones formed by three consecutive columns of the chart, when combined with the complementary of the key color, forms a perfected harmony. For example, a selection made from the block 7, 8, 9, including colors from each of the scales, combines with hues in scale 14. This class of harmonies can be made exceedingly effective by including the colors lying on either side of the complementary hue, thus contrasting two sets of analogous hues, as 7, 8, 9 with 13, 14, 15, or 4, 5, 6 with 12, 13, 14.

**24.** In Table II, combinations of pairs of spectrum hues will be found useful in connection with the chart of spectrum scales.

It will be seen by Table II that, as a rule, the best colors to combine to give color are those a little beyond the complementary of that color. For instance, No. 3 combines best, not with 12, but with 13, 14, and 15, the best combination being with 14. It is well to observe, too, that the perfected harmonies involve the use of the best combinations.

**25. Triads.**—Up to the present we have considered only combinations of two hues. Let us now look into the combination that can be effected with three hues, commonly termed **triads**.

**26. Influence of the Proportioning of Masses.**—The success of these combinations is dependent as much on the proportioning of the masses as on the hues themselves. Some colors combine harshly if used in equal masses, but if skilfully proportioned one to the other, the harshness is overcome and a satisfactory harmony produced. Any of these combinations can be varied unlimitedly by the introduction of several tones of the various colors given, or by

combining these colors with neutrals—black, white, gray, or gold—using these neutrals in outlines or in small masses in order to emphasize the effect.

These hints on color harmony are given, not as hard and fast rules by which one can mathematically calculate

**TABLE III**  
**COMBINATIONS OF THREE HUES**

Hue	Combined With	Hue	Combined With	Hue	Combined With
1	{ 1 8 13	7	{ 5 11 17	13	{ 4 10 S. 2 15 T. 1
2	{ 2 10 14	8	{ 6 S. 1 10 S. 2 15 S. 2	14	{ 1 8 Br. Green
3	{ 2 7 14	9	{ 5 Br. Blue M 6 T. 2	15	{ 16 T. 2 5 S. 1 10
4	{ 3 11 16	10	{ 2 S. 1 Br. Blue D 9 S. 2	16	{ 3 S. 2 7 12 T. 1
5	{ 3 8 14	11	{ 1 5 T. 2 13	17	{ 3 9 S. 2 13 S. 2
6	{ 5 12 18	12	{ 7 T. 1 11 S. 2 17	18	{ 11 S. 1 6 T. 2 1 T. 2

exactly what is required in each instance, but as suggestions on lines along which he can experiment and effect combinations that are efforts in the right direction and likely to lead to success.

In making these experiments it should be borne in mind that one must study the relations of colors to each other very closely, both in pairs and in triads, before any attempt

is made to more complex arrangements. Red and blue used together in their full strength are harsh, and tints and shades of these colors should be experimented with as well as combinations of each of them with another color until one is thoroughly familiar with the mental effect that is produced by the combinations of certain shades, tints, and hues. Combinations of three colors can then be experimented with, increasing the intensity of one over another in order to give it prominence. But the mind should be thoroughly familiar with the effect that one color has on another before complex arrangements requiring two or more colors in combination with neutrals or with shades of other colors are attempted.

#### COLOR SCHEMES FROM NATURE

##### **27. Natural Forms That Furnish Color Schemes.**

There is probably no more fruitful source of color ideas than nature itself. The colorist awake to his studies can see in every object before him combinations of lights and shades, tints and tones, that in themselves are pleasing. Observe, for instance, the beautiful blending of color in the rainbow. The several spectrum colors are here softened by the atmosphere, modified from simple contrast, and blended one into the other to form a beautiful arch that is not harsh in any of its combinations, as the effect is softened by atmospheric influence. However, it is not with such brilliant subjects as this that the colorist is to deal in studying nature for color schemes. We have in all objects a range of color effects that is so varied that in two examples of the same subject we find separate ideas. In the sky, in the water reflecting the sky, in the earth and all vegetation growing therefrom, we find a myriad of forms and suggestions abundant in color that is wonderfully harmonious and wonderfully fit. While it seems scarcely necessary to enumerate the natural forms from which one might draw a color inspiration, a few of them might be pointed out as follows: Flowers and leaves, fruits and vegetables, insects, such as butterflies, dragon flies, bees, etc., the plumage of birds, the coats of animals, shells, fish,

metals, minerals of all kinds, and all articles that have been affected in color by age, action of the elements, or heat. Gold, silver, copper, brass, bronze, and steel furnish a multitude of suggestions for color schemes, particularly when color-tarnished, oxidized, or discolored through unequal heating. The same object will never produce the same effect under precisely similar conditions.

Figs. 7, 8, 9, 10, and 11 clearly illustrate that the general appearance of a design is materially affected by changing the color scheme, and therefore one should always alter his color scheme either in arrangement or in depth of tone in order to produce the best effects.

The success of a color scheme depends as much on the proportion as on the combination, and in changing a scheme of color from nature that is particularly pleasing, one must be learned to be able to estimate, as nearly as possible, the proportions in which nature has used the various colors in order to produce the apparent effect, and also the arrangement of the hues and direct digression in order to blend one color into another, as an unwise combination of these will be very likely to result in a direct reversal of the end sought.

In Fig. 12 is shown a suggestion for a block of squared paper about  $2\frac{1}{2}$  inches each side. This is subdivided at intervals of  $\frac{1}{4}$  inch so as to make a series of 100 squares, 10 on each side. Thus, in analyzing a color scheme, the percentage of each color, tint, and shade can be estimated and painted with brush on the series of squares in order to produce a proper record. In Fig. 12, the scheme is from a butterfly's wing. Experiments of this kind are very interesting and exceedingly valuable in training the mind, not only to appreciate color, but to appreciate its proportion.

**28. Requisite in Training Color Perception.**—The first requisite in training the color perception is that the student should use color constantly, and become thoroughly familiar with it. He should avoid all combinations that he knows to be bad color and not attempt brilliant strokes of color. The combinations of color that appear soft and



1955  
PUBLIC  
TRUST

unpretentious are the ones he should study most closely, while glaring figures in brilliant hues should be strenuously avoided either as subjects of study or experiment until a thorough appreciation of color harmony is understood.

**29.** Careful consideration of the standard combinations will so train the eye that it will soon be able to "feel" the harmony or discord of a combination without reasoning out the theory, just as the ear will recognize a harmony or discord in music without realizing the intervals. The experienced colorist will conceive a mental picture of the way he wants his design to appear and will work out the design accordingly. The inexperienced designer is likely to endeavor to work up a color scheme by experiment—this almost invariably results in disaster. A color scheme should be worked out mentally as a whole, each hue having its value and proportion and the whole general effect clearly understood so that the designer has but to work it out on his cartoon.





# BOOKCOVER DESIGNING

---

## BOOKBINDING

---

### EARLY STAGES OF THE ART

**1. Character of Bookcover Design.**—The modern designer of bookcovers, book plates, and other productions of the printing press is confronted with a problem entirely different from that demanding solution by the designer of repeating ornament. Bookcover designs usually contain, first, the title of the book, and second, some piece of characteristic ornament that is in harmony with, or symbolic of, something contained in the book itself, or the subject on which it treats, or of the series or set of which it is a unit. A book plate differs from a bookcover in the fact that it usually faces the title page and its elements are characteristic of the owner of the work, and are not associated with any detail in the narrative. The initial letters that are sometimes used to head the chapters may be associated with the same ideas as the cover, or they may consist of simple abstract ornament in no way associated with the chapter that they introduce.

It should be borne in mind, however, that while harmony of idea is not demanded, discord must be avoided, and a book the contents of which is suggestive of classic history or art could not be printed with initial letters designed in the Gothic style, except through a violation of the fundamental principles of design.

**2. Origin of Bookbinding.**—It must also be borne in mind that every device of a utilitarian character had at the

time of its origin a primitive form, and the associations of this form, from its origin to the present day, have had more or less influence on the character of its design. The old methods of engrossing on parchment facts for preservation, made these documents very rare and valuable, and the scrolls on which they were usually written were wound around a stick and placed within a metallic tube in order to preserve them. The makers of these metallic tubes, usually silversmiths and goldsmiths, therefore were in reality the first bookbinders. In later periods, pages were engrossed similar to those in our paper books and bound together to form a volume not unlike our common books of today. But still the binder was employed only to sew the pages together, and the silversmith and goldsmith did the elaborate work of designing and fitting it to the book. Naturally, these volumes were a very expensive lot of documents and could be possessed only by the most wealthy.

The introduction of printing and the printing press brought books within the reach of every one and revolutionized book printing, bookbinding, and bookcover designing.

**3. Character of Early Bindings.**—In the earliest times of bookbinding, the work of the cover was in the hands of the leather worker and the goldsmith, as the bookbinder, as understood by us at the present day, had not then come into existence. Rare and beautiful volumes, representing hours and hours of laborious productions of the scribes and the artists, were incased in befitting covers of gold and silver or ivory, and frequently enriched with precious stones. Such volumes were obtainable only by the king, or, possibly, the library of a church or monastery.

When princes and nobles took an interest in matters literary, as they did at a subsequent time, manuscripts became more common, and these costly bindings were superseded by bindings of velvet and satin and, afterwards, by leather. The invention of printing, making books producible in a large quantity, made a still less expensive material desirable, and leather formed the binding material of nearly all books,

but the decorative work was carried out on its surface in gold leaf and enamel colors.

During the time of Charles VIII and Louis XII in France, many books were collected for the royal library, and Anne of Brittany, who was the wife of each of these monarchs and shared with them the love of literature, bought and ordered specially printed volumes for her library.

**4. Heraldry in Bookbinding.**—It will be necessary to consider only a few of these early bindings in order to obtain an idea of the great pains that was taken with this class of work, and to understand that the style of ornament prevailing in each particular period influenced bookcover design more than did the contents of the book itself. The fact that the books were bound individually and not in numerous quantities, led each king or queen to stamp on the cover his or her coat of arms or initials, and this serves to identify many volumes for us at the present day.

Stamping the owner's coat of arms or initials on the cover of a book was in reality the prototype of our modern book plate, for the book plate stamped on or in a book is usually placed there as a mark of ownership rather than in any way relative to the subject bound.

---

#### TOOLS

**5. Early Designs Governed by the Tools.**—To fully understand the character of early bookcover designs in leather and gold, it must be borne in mind that the limits of the design were governed very largely by the *tools* in use by the leather worker. This term **tools** refers to the implements on the end of which little devices, or ornaments, are cut; each tool is separately used to transfer the design to the leather.

When leather was first used as a bookcover material, most of the work was done in the monasteries, as there were no regular binderies at that time. The designs that these monks and craftsmen invented were made up largely of motives borrowed from manuscript, initial letters, etc., and from

carvings in wood and stone that they would naturally observe in the various churches and monasteries.

**6. Influence of Increase of Binding on Character of Design.**—The love of learning and the spread of books became so important, however, that the monastery workshops were unequal to the task, and leather workers of all sorts were pressed into service to bind the numerous books that were springing into existence. Saddlers, harness makers, and even bootmakers were called on to do the work, and the new trade of bookbinding was influenced not only by their skill as craftsmen, but also by the character of the tools that they had been using in their various crafts, and to a certain extent by the designs that they had used for years in the ornamentation of boots, saddles, and harnesses for royal personages. The artisans themselves were humble men, few knowing even how to read and write, and we therefore find the earliest leather bindings stamped with devices that are in no way relevant to books or book work, but that have become characteristic of bookbindings of the present day simply on account of this original association.

The binder being familiar with the extent to which he could interchange his tools, conceived the general scheme of his cover decoration, then by a combination and repetition of the forms on these tools created his design. These designs therefore varied according to the fertility of the mind of the designer and the prevailing tastes of succeeding periods of time. It is necessary, therefore, that familiarity with these tools should be possessed by the student in order that a real understanding of bookcover designing may be attained.

**7. Origin of French Tools.**—In the period of Louis XII of France, the forms of the tools used were borrowed from Italian devices, wherein arabesque figures were stamped in black on white paper; but the French worker soon learned that this heavy black mass, though suitable to a white page, was utterly unsuited for stamping in gold on the cover of a book. It therefore was usual to stamp the devices in outline, or sometimes in outline with the interior slightly

shaded, or *azured*, as this form is technically known, thus giving the binder not only a means of varying the weight of his device but also a variety by a combination of which strength or lightness was acquired.

These tools in their three forms are illustrated in Fig. 1, where at (a) are shown the tools as derived from Italy in their solid form, at (b) their variation by simply the use of outline, and at (c) their further variation by the shading of the outline in order to give a little more strength. The

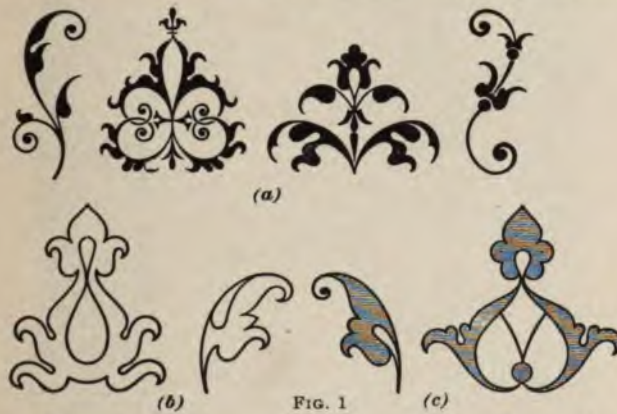

form of these devices is plainly borrowed from the arabesques of Italy, and, separated from the elaborate interlacings with which they were there associated, show their outline to be distinctively of oriental or Arabian origin, from which they derived their name as *arabesques*. These simple devices connected by a long line of scrolls and interlaced bands formed the entire theme of bookcover design during the first period of the French Renaissance.

#### EARLY INFLUENCES AND STYLES

**8. Groller.**—The styles of bookcover design that prevailed in different periods, unlike the style of ornament that is characteristic of each period, usually take their names from their designers rather than from the ruling monarch. For instance, many of the bookcovers made during the reigns

of Louis XII and Francis I are designated as the *Grolier style*, inasmuch as the art was introduced into France from Italy by a great collector of books, named **Grolier**; this style includes both the prevalent character of binding found in Italy and a later style in France.



FIG. 2

Grolier assisted in the production of many volumes that were printed on the press of Aldus Manutius, a celebrated Venetian printer, and in recognition of his services many volumes were beautifully bound for Grolier's own library. In the year 1545, Grolier obtained the position of Treasurer-General in France, and held it until his death, in 1565, thereby

establishing his great library of three thousand volumes of fine Italian bound books in the heart of France, near Paris.

These books were mostly bound in morocco, the finest skins for which were procured from the Orient, though a few were covered with calfskin, the earlier works possessing the characteristics of the Italian Aldine press, the later ones being modified under the influence of binding in France.



FIG. 3

**9. Characteristics of Italian Bookbinding.**—In Fig. 2 is shown a binding in the Italian style on a book printed in Venice in the year 1525. This shows the characteristics of this Italian work and the form of arabesque patterns that were introduced into France during the reign



of Louis XII. Here are seen the impressions of the tools of the Aldine press, pointed out in Fig. 1 (a), united with the scrolls and arabesque panel ornament characteristic of the Italian Renaissance. In Fig. 3 is shown another design from Venice bound for Grolier, whereon a panel is left in the middle that subsequently might receive a coat of arms.



FIG. 4

Here the tools are still similar to those used on the Aldine press and give a fair idea of the style of book design when first introduced into France.

10. In Fig. 4 is illustrated a book that was bound under orders of Henry II for Diana of Poitiers to be placed in her

library, and stamped on its cover are the interwoven initials H and D indicative of these two names, while in the upper right-hand and lower left-hand corners of the central panel are the three intertwined crescents of the coat of arms of Diana. The cover of this book was of citron morocco and is a characteristic binding of this period, 1545.

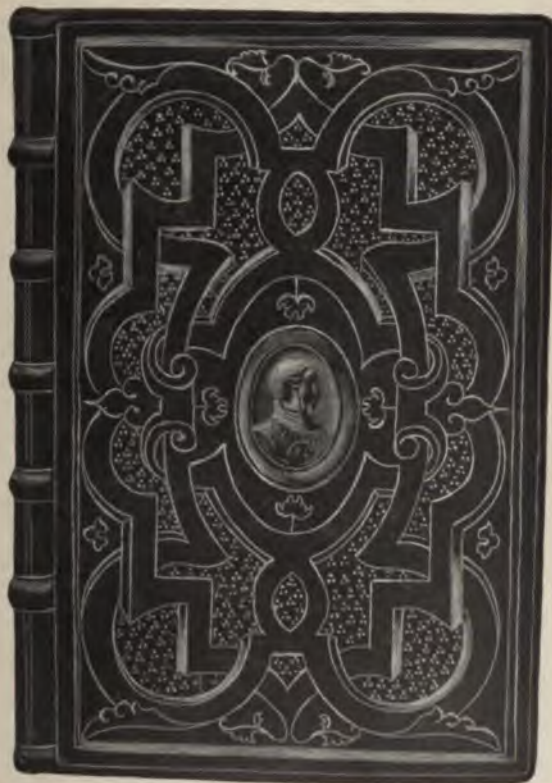

FIG. 5

11. The bookcover shown in Fig. 5, bound in 1556 by Henry II, shows a type of ornament entirely different from the previous example, and in the center is a raised medallion with a profile portrait of the king himself. This cover was of brown morocco leather with painted bands and gilt

trimmings; except the portrait, no initials or other devices were placed on the outside of it.

**12.** The bookcover shown in Fig. 6 was bound in 1562 for Katherine de Medici, and the coat of arms on its center was that of her family. The back of the book was ornamented in each panel with a crowned K, the initial of her



FIG. 6

name, and the whole was executed in dark blue, green, and gold on leather of olive morocco; however, the central oval panel around the coat of arms was painted red.

**13.** In Fig. 7 is shown a design executed in brown morocco for Henry III, with gilt ornamentation including

the cipher initials of the king and queen and the coat of arms in the center. It will be observed that the ciphers and fleur-de-lis forming the ornament on this design partake of the character of a spot and powder design limited at the angles by especially designed corner pieces.

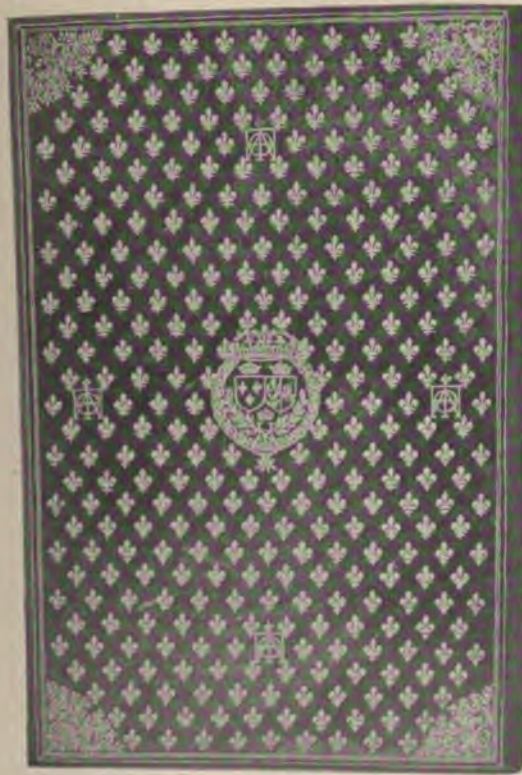

FIG. 7

14. In Fig. 8 is shown a design executed in red morocco for Henry IV, in 1604, the central ornament being composed of his coat of arms; in the outer limits of the border surrounding it are found his initials intertwined with those of his queen, Margaret of Valois.

15. The change in the character of design at this period can be readily compared by reference to Fig. 9, which is a

design in brown calf executed for Margaret of Valois, 27 years before that shown in Fig. 8. The tendency throughout—simplicity rather than complicity—is well illustrated.

**16. Tendency of Early Bookbinding.**—The earliest efforts to enclose books in suitable and appropriate bindings tended to make those bindings and cover designs more

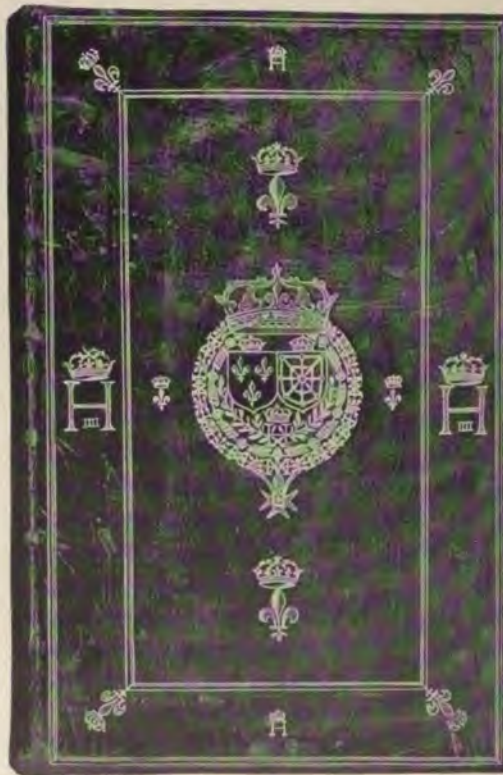

FIG. 8

characteristic of the owner of the book than of the book itself, and each design being executed but once, and that on the bookcover itself, rendered it advisable to spare no money in order that the quality of the cover should be suitable with the value of the work it protected. At the

present day, however, we have an entirely different proposition; our books are printed in editions varying from one thousand to ten thousand copies, and some limited editions of a few hundred copies. Our cover designs must therefore be reduced to the limitations of practical printing and at the same time be suitable and attractive. Some of these covers

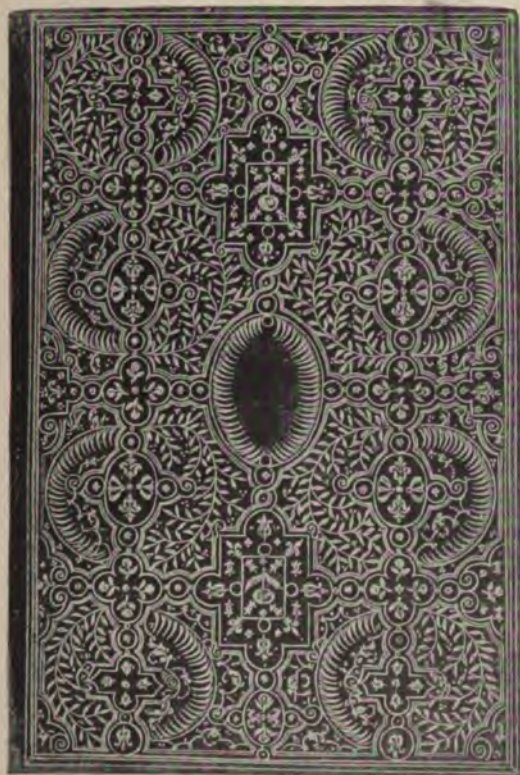

FIG. 9

are printed on paper, others on cloth, others on parchment, and a few, even at the present day, on leather. In most cases, these covers are backed up with a heavy cardboard or pressed-paper filling, and the material, as well as the design, serves not to protect the book, but to ornament its outside, the true cover being the binding material itself.

**17. Limitations of Field of Design.**—The designing of bookcovers is practically unrestricted. There are no considerations of proportion concerning its dimensions that need in any way affect the relative details of the work. The design may be executed in black and white, in gold, or



FIG. 10

in color, the only considerations necessary being the expense of production and the handling of the material in a manner suitable for the die press.

Certain classes of bookcover design require an imitation, perhaps, of what has been done in the past, such as the examples shown; other classes may require the enclosure

of the cover in a border with corner pieces, in which case the design may partake of the character shown in Fig. 48 of *Practical Design*; a simple design in appropriate historic letters would also be perfectly proper without any ornament whatsoever, or, possibly, this style of letter with a slight interweaving of historic ornament. In any case, the designer is left almost entirely to the dictates of his own ideas influenced by the character of the book for which he is to design, and a few suggestions is all that will be necessary in order that he should learn to apply the principles of design to this class of work.

18. In Fig. 10 is shown a binding executed for Grolier, in which the lightening of the tool effect by means of outlining is very apparent; a heavy black interlaced pattern is stamped on the leather, the background is powdered, and the tools outlined in gold and their interior powdered. The Italian motto, "Io. Grolierii et Amicorum," is stamped on nearly all of Grolier's books and, in reality, represents his book plate.

19. **Francis I Bookcovers.**—During the reign of Francis I, the influence of French taste on bookbinding is seen by the introduction of powdered devices for books.

In Fig. 11 is shown a powder effect within the dolphin device and the fleur-de-lis are alternated vertically and horizontally; this device in varied forms was very popular in subsequent periods, as may be seen in Fig. 12, which was a binding for Louis XIII, wherein the powder effect is secured by means of the fleur-de-lis and the crowned L. Other devices



FIG. 11

were used in powder effects and also interwoven in arabesque design, as the double H of Henry II, the interwoven crescents



of Diana of Poitiers, and the H C, and L A for Henry and Catherine, and Louis and Anne of Austria, in their respective reigns.

**20. Le Gascon and De Thou.**—After the time of Grolier, whose name is associated with all French bookbinding, up to the period of Charles IX, Le Gascon and De Thou



FIG. 12

appear prominently as book collectors and influencers of bookcover design. Jacques August De Thou was appointed to the custody of the books in the library of Henry IV, and it is to him that we are indebted for the preservation of nearly the entire library of Katherine de Medici.

**21. Styles of Henry II and Henry III.**—It was after the reign of Charles IX that a change of style began to take place in French bookbinding. The sides of a book were divided into small compartments by geometrical lines, and though at first these compartments were devoid of ornament, during the reign of Henry III they were occasionally filled with a stamp representing the crucifixion. Henry II frequently bound books for himself on which he stamped the triple crescent of the coat of arms of Diana of Poitiers; but his son, Henry III, took life more sadly and decorated his covers with religious subjects and skulls until after he became king, when the designs became more cheerful, as shown in Fig. 7.

**22. Style of Margaret of Valois.**—Margaret of Valois, sister of Henry III, bound her books with a powder design composed of marguerites or roses enclosed in ovals of conventional leaf-like forms. She also endeavored to relieve the restraint caused by the regular framework by entirely filling its spaces with foliated figures and a multitude of vines that were extremely graceful.

**23. Fanfares.**—The style of binding found on the books of De Thou is termed **fanfares**, on account of that word appearing prominently in the title of one of the earliest volumes bound in this style. They furnished models for other books, and a binder known as *Le Gascon*, who was probably an apprentice of the binders that worked for De Thou, introduced them into his designs extensively. In fact, the execution of this style of binding made Le Gascon the most prominent person in bookbinding after the days of Grolier. But it must be remembered, however, that Grolier was a book collector and not a binder and that through his efforts a style was developed that made a great binder like Le Gascon a possibility.

**24.** In Fig. 13 are shown the tools used in the execution of these fanfare covers, all of which, except the little branches, are azured or ruled with a light surface tinting. Le Gascon developed these tools into still lighter forms, by dotting their outline so as to make it as delicate as possible,

as shown in Fig. 14. He developed great individuality, but always employed the stiff framework of the fanfare on important bindings. His style gradually developed, however, and the reduction of the Aldine tools to the dotted outline is characteristic of his work and gives a remarkable brilliancy of effect to the best of his bindings.

**25. Style of Louis XIV.**—The beginning of the reign of Louis XIV, when Le Gascon was binder to the king, might be considered the period of the highest development of French literature. In bookbinding, however, it was literally a golden age, as the application of heavy stamps and gilding rendered the bindings



FIG. 13

less delicate than their predecessors and in certain instances positively vulgar in their glitter. The royal arms were stamped on the covers in exaggerated proportions, and heavy borders of gold in geometrical patterns were printed around the edges. These borders, being printed from revolving wheels, were absolutely uniform and lost the charm that is ever characteristic of purely freehand work. In some examples, where the courtiers followed the style set by the king, a border varying in width from 1 to 3 inches was run around the book by means of one of these wheels. Sometimes there would be two or three narrow borders, one within the other, usually with a heavy corner piece to mark the return, but very frequently without any attempt at a corner piece at all, allowing the corners to take care of themselves where the ruled work stopped. Sometimes the entire side of the book would be engraved in this incongruous style of repeating ornament, making the bookbinder a mere machine without an opportunity to exercise skill or taste and rendering all books so alike in character as to make them appear commonplace.

As a consequence, we find no great bookbinder in France during this period, and the reign of Louis XIV, grand as it may have been politically and artistically, developed no great book lover like Grolier or bookbinder like Le Gascon. The tools used by Le Gascon (then called "tools of the 17th century") were still in use and have remained in use to the present day, and form the stock in trade of the best binders at the beginning of the 20th century.

**26. Jansen Style.**—It was due to this elaboration and overgilding that the reaction known as the **Jansen style** took place. This consists of soberly bound volumes absolutely devoid of gilding on the sides, and depending for their beauty on the character of the leather itself. These books were bound better, in a technical sense, than the earlier ones, regardless of the fact that as works of art the covers of the earlier books are more interesting. But the binders of books were giving more attention to keeping the leaves intact and enclosing them in a proper protecting cover than to placing the leaves in a haphazard manner in an elaborately decorated portfolio.

**27. Mosaic Binding.**—Some binders, however, were still interested enough to keep up the traditions of Le Gascon, and shortly after the death of Louis XIV a new style of leather binding sprang into existence as the work of Padloup; this is the **mosaic binding** and is certainly the most elaborate and remarkable of its kind. Its chief characteristic is that it is in several colors, formed by different leathers inlaid within one another.

The bindings in Grolier's time, too, were of polychromic decoration, but the colors were painted on them with somber tinted enamels. But it remained for *Nicholas Padloup*, in the reign of Louis XV, to introduce the style of work shown in Fig. 15, which has since become characteristic of him. In this example, bound for the Duchess of Orleans, the



FIG. 14

center quarterfoils were red on a ground of deep olive green and the rest of the binding was a brown leather sharply outlined in bright gold.

28. **The Deromes.**—Contemporary with the bindings of Padloup were those of the **Deromes** (a number of brothers, the most prominent of whom was known as the *younger*

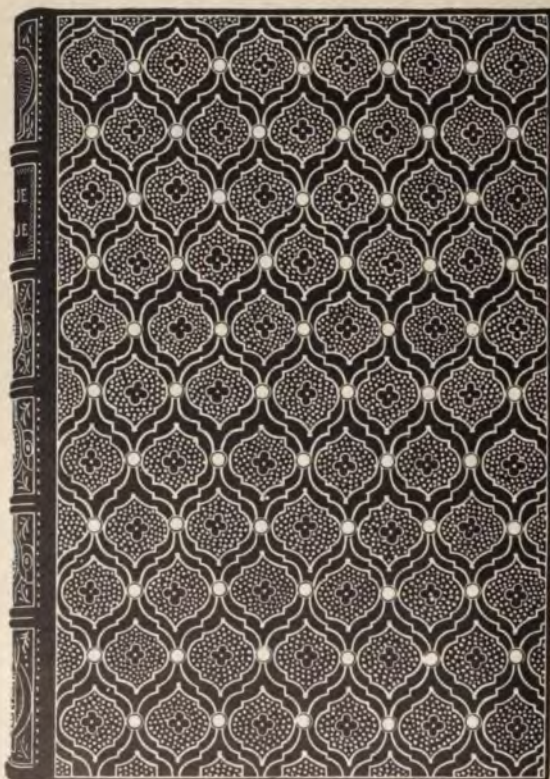

FIG. 15

*Derome*). The characteristic binding of Derome is entirely different from that of Padloup, and as all the mosaics of this period were attributed to Padloup, Derome gets credit for all bindings wherein a tool is used representing a bird with outstretched wings, thus giving a lightness and vivacity to

the design. Derome's covers usually consisted of a lacelike foliated border suggestive of wrought-iron work, as in Fig. 16, from which he undoubtedly borrowed ideas, as the 17th century smithery work had reached a high scale in art



FIG. 16

in France. These openwork borders were heavily tooled, and the motives borrowed from the ironwork of the period were capable of immense variation, so that of Derome's bindings it is not likely that there are two exactly alike. The tools used by Derome are shown in Fig. 17.

**29. 18th Century Bookbinding.**—In the 18th century, the designs became heavy. Padloup and Derome had no successors of importance, and the few new tools possessed nothing of importance or interest; they serve only as a key to the period of certain bindings, if the student chooses to so use them at the present day. The development of the book-cover from its earliest condition to its present form should be thoroughly understood if one desires to design book-covers intelligently in the present period.

**30. Knowledge of Styles Necessary to the Designer.**—In bookbinding, as in everything else, one style was evolved from another. The Aldine press in Italy, being the pioneer printer of ornament, produced the style that was taken by Grolier to France and developed there into a French style. Then followed the powdered styles and the brilliant fancies of Le Gascon, which in turn gave

place to the mosaics of Padloup and the vigorous borders of Derome.

Throughout all, the key to the period of each binding is the style of the tool used; and a knowledge of the characteristics of these tools, whether used in the present day for an imitation of antique bindings or for the study of antique bindings to locate their periods, is essentially important.



FIG. 17

**31. Comparison of Bindings of Different Countries.**—The art of book-binding was developed to a higher point of excellence in France than in any other country. True, it originated in Italy, but Italy was soon outstripped by France in style and ingenuity, while Germany attempted to do no more than paste an ornamental book plate inside of a volume, acknowledging thus her lack of skill to adorn the volume externally. To Germany, therefore, we owe the invention of the book plate.

Only one great binder appeared in England during this period and even he cannot be compared with his contemporaries in France.

#### MODERN BOOKBINDING

##### 32. Character of Modern Binding.

It must not be supposed that the binding of books in individual copies, the covers of which are ornamented with particular devices, has been confined entirely to antiquity. It is quite customary at the present day to bind books with covers to suit their owner or match the general bindings of his library. In fact, nearly all French and German books and a large number of those published in England are bound in paper only, so that the purchaser may have them placed in covers that satisfy his taste.

The designing of bookcovers, then, even at the present day, may require a theme that can be neither executed by hand on leather work or duplicated on the press. As the former is a higher branch of the art and is more closely allied with the practice of the past, it will be considered first, but let us look first into the general process of binding a book, as the designer of the cover must be familiar with the details through which the volume passes before it reaches his hands for completion.

**33. Process of Binding.**—In bookbinding there are two separate and distinct operations, usually termed *forwarding* and *finishing*. **Forwarding** consists in the assembling of the leaves and the preparation of the book for its cover, the putting on of that cover and the completion of the book ready for its exterior decoration. **Finishing** consists in the decoration of the cover and of the back of the book; forwarding, therefore, is a mechanical process; finishing, an artistic one.

It has been expressed as the opinion of one of the most prominent binders of the day, that a book neatly and cleanly covered is in a very satisfactory condition without any finishing or decorating, and that many people are in accord with this idea is evinced by the fact that so many books are bound in plain leather without any decoration on their exteriors except a device or title by which they can be recognized. It will be remembered that the Jansen books, described in Art. 26, consisted simply of a well forwarded book with a minimum amount of gilding on its cover, and in some cases none at all.

**34. Securing the Sheets.**—In modern bookbinding, the first operation of the binder is to fold all the printed sheets into a section and to gather these sections together in regular order so as to form the volume. After this, the sections are taken one at a time, placed in a frame to hold them, and then sewed, with a continuous thread, backwards and forwards through their backs, thus uniting them and at the same time securing them to upright strings that are fastened in the sewing frame across the backs of the sections,



as shown at *a*, Fig. 18. As a matter of fact, after the completion of this process, the book is "bound," and all that is subsequently done to it is for the purpose of protecting this binding. The decoration of the latter part of the work, to make it beautiful as well as useful, brings the element of design into bookbinding.

The book is now ready for the forwarder, who completes the work of binding to the pasting on of the cover. The back of the book *b* is made by him and rounded to shape; the millboards *e* that are to form the covers are carefully squared and secured by leather or cloth bands to the sheets that are sewed in.

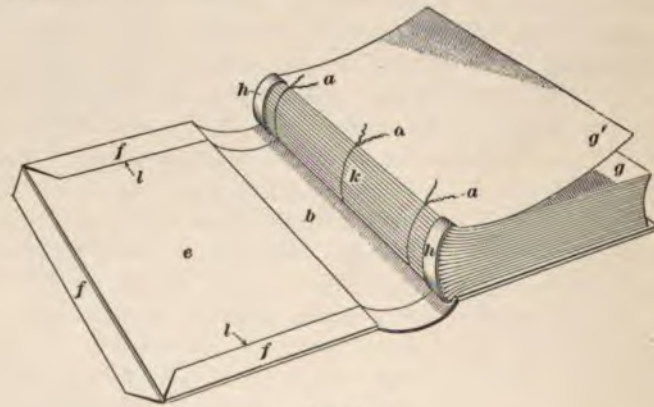

FIG. 18

The sides of the volume are thus protected by millboards, usually termed "boards" for brevity, which are themselves protected, as shown at *f*, by a covering of leather, vellum, or silk, as of old, or of linen or paper, in most modern work. The edges of the volume are protected by the projection of the boards, while the upper edge is cut smooth, and sometimes gilded to prevent damage from the accumulation of dust.

**35. Classification of Bindings.**—This protecting cover over the boards, and the extent to which it is subsequently decorated, determines the character of binding under which the book is classified. In modern binding there

are four classes—*cloth binding*, *half binding*, *whole binding*, and *extra binding*. In **cloth binding**, the cover is made separately from the book and encloses it after the entire book is sewed. In **half binding**, the cover is made for each individual book as before, but the boards are not entirely covered with the leather, silk, or other material that protects it, but the forepart is covered with something else; books bound in this manner are usually termed *half morocco* or *half calf*, according to the material. In **whole binding**, the boards are entirely covered with the leather or other material of the binding and are commercially termed *full morocco* or *full calf*. In **extra binding**, the whole surface, or such a portion of it as is desirable, is decorated in gold or enamel color. Where a book is to be extra bound, the processes tending to the assemblage of its parts are gone into somewhat more in detail. After the sections are folded, the end leaves *g'* at the front and back of the volume are added to protect the most exposed pages. Then the sections are sewed, as before, and the volume passed into the hands of the forwarder, who makes and shapes the back of the book, attaches the boards, and laces them to the ends of the strings *a* to which the forms have been sewed. After the edges have been colored or gilded, which is usually done at this stage, the head-band *h* is sewed in at the head and tail, and the back *k* lined with cloth or leather to keep the head-band in place and strengthen the back.

**36. The Covering Material.**—If leather is now applied to cover the book, its edges must be carefully shaved off in order to make no ridge at *l* where the edges fold over on the inside; and after being pasted securely to the cover, the depression caused by the overlap is filled with an evenly cut piece of paper so that it may be perfectly smooth to receive the first or last end paper *g'*, which is cut to shape and pasted down, leaving only the leather borders of the boards uncovered. This completes the forwarding of the volume; the finishing on the leather consists of a decoration, in gold, with the tools that have been described.

**37. Decorating the Cover.**—The method of operating the tools and applying the decoration is very simple. The pattern, having been drawn on paper, is marked on the leather after it has been washed with vinegar and water. The white of an egg, which has been well beaten up and allowed to stand, is carefully penciled over the pattern, after which it is generally wiped with oil. Gold leaf is now applied with a pad of cotton wool, and the pattern, plainly visible through the gold leaf, is pressed into the leather with the tools heated to a temperature of a little over 200°; the waste gold is then removed by rubbing with an oiled rag.

**38. Character of the Cover Design.**—The design must be one that can be executed conveniently with the means at the finisher's command; that is, by means of the tools with which he does the embossing. It is an unfortunate fact that at the beginning of the 20th century nothing has been developed toward a new style of bookbinding characteristic of the present age. Grolier lived in the 16th century and Le Gascon in the 17th century, and even in the 18th century we have the mosaic borders of Padloup and the heavy lacework borders of Derome borrowed from or inspired by wrought iron, and yet the most beautiful bindings that we find executed in the 19th century are simply imitations of those that preceded them. Even in France, where bookbinding was developed and has flourished to such an extent, we have nothing worthy of consideration during the past century, for the French Revolution and the long succeeding wars not only prevented further development of the art, but even caused the traditions to disappear.

The foremost bookbinder of the 19th century was Trautz, a German; his work caused the French to regain some of their former enterprise. The chief beauty of the work of Trautz is its conscientiousness; he always did his best, and being a student of ancient methods, revived the tools of Le Gascon, Derome, and Padloup.

**39. Modern Designs.**—In individual bookbinding of the present day, it is very hard to direct the student on what

lines to follow. Many binders are content to follow identically the styles of Grolier, Padloup, and Derome, but this is altogether wrong, as they are out of sympathy with modern advancement. They may be more perfect in design than anything that has recently been created, but to persist in using them is as unreasonable as to confine our designs of art and architecture to the early Greek, for a man's residence today is a thing he requires for his modern wants, however imperfect it may be, and is far better than the style of the early Greek, which is unsuited to his purpose, though beautiful.

**40. Propriety of Design.**—It should always be borne in mind that there should be some propriety of scheme in the design of a binding, and though it is not necessary that a volume on botany should be decorated with floral forms, it is proper that there should be some association between the title, the binding, and the interior of the book. One expensive volume on the subject of glass making was once bound in covers that contained glass panels enameled in color; this is carrying the subject of harmony between title and cover to an extreme that is ridiculous, as glass is naturally highly inappropriate for a bookcover.

**41. Revival of the Jansen Style.**—In a majority of books bound, the Jansen idea of morocco seems to prevail, and few persons except those that are the fortunate possessors of an elaborate library care for individual designs. The demand is growing, however, and the propriety of materials should always be considered. American binders have taken the lead, to a certain extent, in giving a variety of leather to bookbinding and other purposes, but they have not given altogether proper thought to the propriety and application of the leather to the book bound. The binding of prayer books in snake skins is certainly not a very appropriate combination, although this material would be very suitable to the weird uncanny tales of Edgar Allen Poe. The use of alligator, kangaroo, dog, cat, rabbit, fox, sheep, bear, and such skins gives a variety from among which will be found some one more appropriate than all others, as

there are over a hundred kinds of leather that at present are used in the manufacture of pocketbooks, bags, card cases, etc., and all may be used in the binding of books.

**42. Materials for Covers.**—Bookcovers need not necessarily be confined to leathers either. Fragments of tapestry, old silk, brocades, velvets, etc. will enter with great propriety in the designs of certain bindings. A treatise on the upholsteries and decorations of certain periods of art may be suggestively bound in some of the prevailing brocades that were used for upholstery work. The history of tapestry and tapestry weaving suggests some ideas for the cover highly appropriate for this work, and the consideration of the history and development of lace making not only suggests a material that might appear in the cover design, but also suggests a pattern that could be traced out on a leather cover and tooled as in the old methods. A treatise on book plates or bookbinding should certainly be bound in a material that is in harmony with this subject, and a design after the pattern of Le Gascon, or the earlier practice, as seen in results from the Aldine press, would certainly be suitable to the occasion if not carried too severely on the lines of the original. In the same manner, the mosaic bindings of Padloup and the heavy wrought-iron suggestions of Derome may each be pressed into service to be appropriated on certain occasions and for certain purposes and used intelligently in their places.

**43. Cheaper Bindings.**—Leather is very little used for modern bookbinding, and consequently the designers of bookcovers must, as a rule, take into consideration the adaptability of another material. Stamped cloth is the more common material for this purpose nowadays, and the old leather-work designs have been superseded by free and traditional ornament in some way associated with the subject of the volume. There is practically no limitation in the execution of the designs, inasmuch as machinery has been so improved that a pattern may be stamped on the side and back of a bookcover in as many colors as the designer can

use to advantage or the publisher is willing to pay for. A modern bindery with steam power is capable of binding the entire edition of any one work—amounting even to several thousand copies—in the course of 24 hours.

**44. Hand and Machine Binding.**—Here, then, is one strong and essential difference between hand bookbinding and machine bookbinding. In the former the book is bound and then decorated by hand, while in the latter the cloth or other material that is to form the cover is made and decorated apart from the book itself and afterwards fastened in place. Hand work is a slow process, and machine work is a rapid one; in the former the designer really executes the design on the cover, while in the latter he may never see the cover, and simply designs the dies to be used.

**45. Novelty of Design.**—In the attempt to secure novelty of design, a great effort has been made to find special cloths for covering materials for special books, and canvas, burlap, calico, and silk have each been used to advantage, under some circumstances. The special fitness of the association of certain goods, or of the pattern of them, has been used to advantage for certain bookbindings. A book entitled "Gowns and Frocks in Colonial Days" was very appropriately bound in the figured calico characteristic of that period, while another book devoted to the interests of yachts and yachting was bound in ordinary sail canvas, on which was imprinted a line of signal flags bearing the devices of the different yachts of prominence described in its pages. Here, at once, are suggested two styles of treatment—one, wherein the binding material itself is suggestive of the propriety of its use, and the other, where this suggestion is added or increased by the printing on the material of certain characteristic devices, as the signal flags above referred to.

**46. Paper Covers.**—Paper-covered books are of two kinds—one where the edition is valuable and the paper cover is simply put on to protect the volume until its owner shall decide to bind it in leather or other permanent material, while other paper-covered books are usually so bound for

cheapness, and particularly books of the fiction class that are usually read and tossed aside after one reading. From a commercial standpoint, however, the covers of these latter are of as much importance to the designer as the most elaborately tooled leather cover designed in the style of the 16th century.

**47. Magazine Covers.**—Paper covers, in the case of a magazine, must be so characteristic that the magazine is readily recognized by its cover; in the case of a novel, it must be striking in order to catch the eye of the purchaser as it lies on a stand; in some cases it is highly important that it should be symbolic, especially where the subject treated is a religious or political one, in order that the person interested may, from a glance at the design of the cover, form some idea of the material within. In each case, it lies entirely with the designer to decide and settle the material, color, design, and treatment in each individual case, and on the judicious decision of any one of these points frequently depends the success or failure of the entire design.

The styles of design that publishers take to can only be learned by experience, but in cost of production there is little difference between one design and another, except when color is used. A complicated design in black and white will cost no more to print than a simple one, but if one or more colors are introduced, the entire edition will have to go on the press a second time, and perhaps a third, while a die will have to be cut for each printing, thereby increasing the expense accordingly.

### MAKING THE BOOKCOVER CARTOONS

**48. Requirements of Bookcover Designs.**—Modern bookcover designs do not follow closely the styles of the ancient historical bookcovers, owing to the great change in the methods of manufacture. It is necessary, however, that the designer should be familiar with the historical styles in order that he may introduce a historical character into his modern work when the circumstances require it. In submitting a bookcover design to a publisher, there are three things that will determine its practical value: First, its originality; second, the expense of its reproduction; third, its technical perfection.

If the design is not original and attractive, it has no value whatever, no matter how cheap its reproduction may be or how perfect the drawing. If the design be excellent in character, it may be so expensive in reproduction that the excellence of the design is entirely counteracted, for there are limits in every case to the expenditure that can be afforded in the reproduction of even the most attractive covers. A design may be original, simple, and inexpensive to reproduce, yet utterly worthless, owing to the fact that the designer has not properly considered the technical limitations that are concerned in its reproduction.

Occasionally an author may select a design, and, being unfamiliar with the difficulties to be encountered in its execution on the finished book, may overlook some of the foregoing details, but his publisher is sure to discourage its use; and though the design may have been ordered and paid for, its impracticability will prevent the author from again employing the same designer. Such a design, therefore, does the designer more harm than good.

**49. Knowledge of Reproductive Processes Necessary.**—While the originality of a design and the skill of its



execution are of great importance in assuring its acceptance, it is necessary that the drawing be technically correct in every detail and that it can be used by the publisher without the slightest alteration to suit it to commercial requirements. The prospective bookcover designer must therefore give careful attention to the commercial requirements and limitations in the reproduction of modern bookcover designs, and he must be practically familiar with every detail of the processes that a design passes through, from the time the cartoon leaves his hands until its counterpart appears on the finished book.

---

#### CLASSES OF BOOKCOVERS

**50.** Bookcovers, in general, may be divided into two classes: the *tooled bookcover* and the *printed bookcover*. The tooled bookcover is entirely hand work, the printed bookcover entirely machine work, the former being the ancient and historical method, the latter the modern commercial method.

Tooled bookcovers are rarely used at the present day except for rare editions of historical works, or for single books that are bound for individuals. Designs for the imitation of tooled covers to be executed by a printing process are made in precisely the same manner as other printed designs hereinafter described, but designs for actual tooling are usually made by the craftsman himself and executed by him on the finished leather binding.

---

#### TOOLED BOOKCOVERS

**51. Modern Tools and Tooling.**—The tools used in modern bookbinding vary in form and design from those used in historical binding, as shown by comparing the impressions in Fig. 19 with Figs. 1, 11, and 14, but are often combined with the historical designs to fulfil some modern requirement. Each tool consists of a brass form, or stamp, in the end of a wooden handle, that is heated and pressed into the leather to form a detail of the design. The flowing lines connecting separate details are executed

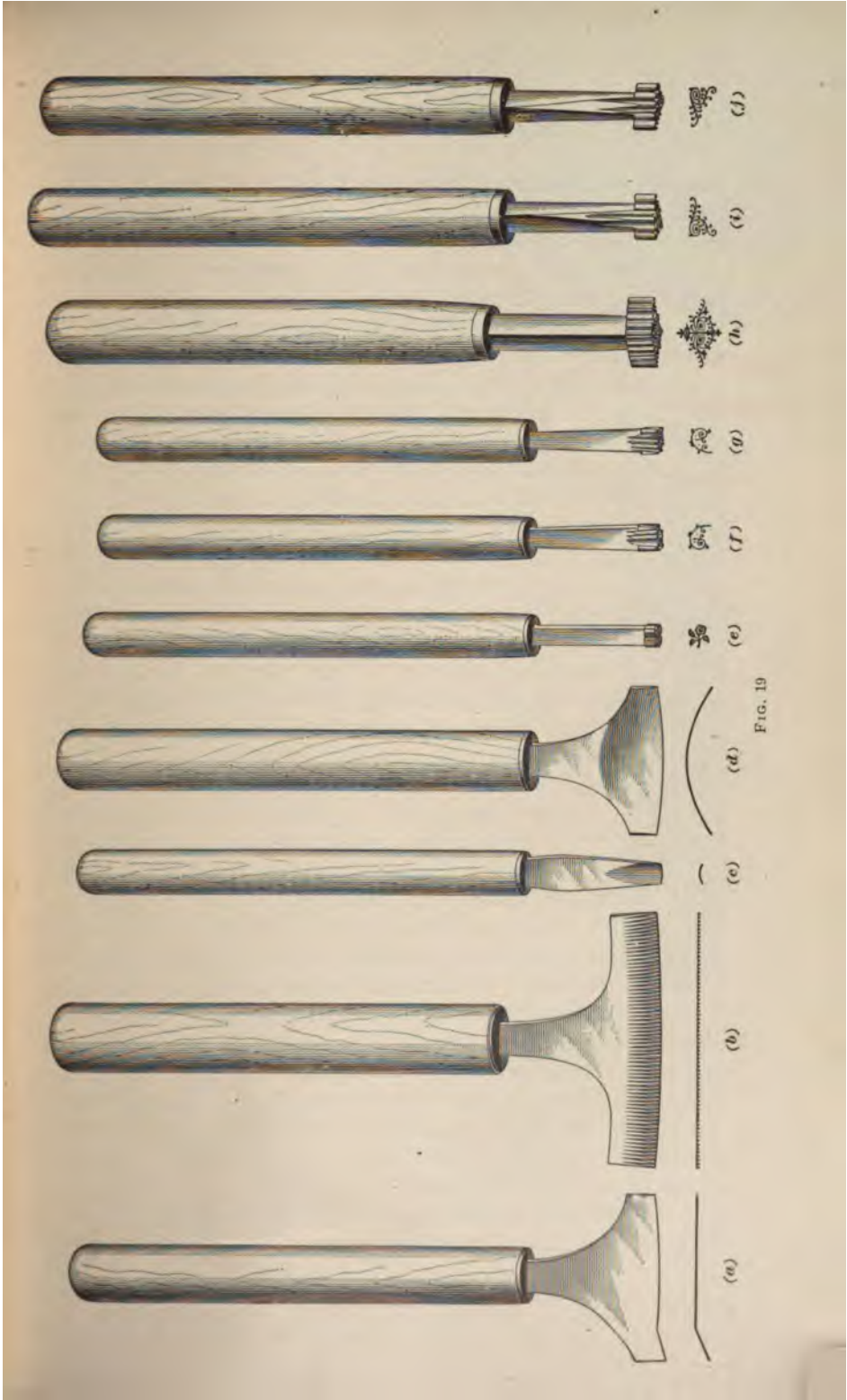

with curves similar to those shown at (*d*), varying in form so that the lines can be carefully followed and the design worked out in detail.

The forwarded and finished book, complete in its leather cover, is turned over to the craftsman for tooling. He sketches his design in pencil on thin paper, working up all the curves for the entire cover very accurately, and when completed mounts it on the book by means of a little paste at the corners. With his tools heated to a temperature somewhat over 200° he then presses these pencil outlines through the paper into the leather, using different tools in order to form the outlines and especially made devices, if necessary, to carry out certain details of ornamentation.



FIG. 20

In Fig. 20 is shown a modern tooled book back executed with the tools shown at (*b*), (*h*), (*i*), and (*j*), in Fig. 19. It will be observed that comparatively few tools were required to do this work. Long flowing lines can be made by a combination of *gouges* (*d*) or curved tools, and the devices can be repeated frequently by several *stamps* containing such ornaments as are required.

After the design is executed, the paper is removed from the leather, and if the work is to be further ornamented with gold leaf, further tooling will be necessary.

Where the plain design is pressed into the leather it is called *blind tooling*; where gilded, it is usually referred to as *tooled in gold*. Where gold is to be applied to the cover, a *size* composed of albumen or other fluid material is applied over the entire design with a fine camel's-hair brush, and when dry, small pieces of gold leaf are laid over the depressions caused by the blind tooling, and with the tool reheated are forced into the depressions already formed, to which they adhere, owing to the presence of the size. When the entire cover is gilded, the surplus gold leaf is wiped from the surface with a piece of oily cotton, and the leather cover

*tooled in gold* is complete. On the back of the book the title is impressed in a similar manner by means of brass letters set in forms with wooden handles similar to those on the tools. Lines emphasizing the structural character of the *bands* along the binding are impressed with straight-line tools. Small ornaments in the panels formed on the back by these bands are stamped with single tools or occasionally with combinations of several tools, but the character of a properly tooled book is entirely that of the craftsman that executes it.

In commercial work, an entire cover is occasionally stamped in gold as an imitation of tooling and the back alone hand-tooled, and in some instances the entire cover, including the back, is stamped at one time, in imitation of tooling. In such commercial work as this the cover is made and stamped before it is applied to the book, whereas in the true hand-tooled work the book is bound first and the tooling executed afterwards.

While the designer for this class of work has to exercise his ingenuity to make his work entirely original and in accordance with modern ideas, yet a thorough familiarity with historic styles of book tooling will be of the greatest value.

---

#### PRINTED BOOKCOVERS

**52. Various Technical Stamping and Printing Processes.**—**Printed bookcovers** offer the greatest opportunity for designers, as it is commercial work that presents the greatest field for this class of craftsmen. Printed bookcovers are executed on paper, parchment, cloth, canvas, leather, and sometimes even on wood. These covers are printed or stamped with a special press using brass dies, zinc plates, or electrotypes, according to the character and quality of the work required. The designer must know which of these methods is to be used when he prepares his design, as its commercial practicability depends almost entirely on this knowledge. Where brass stamps are used, the design is cut into thick brass plates in high relief and stamped

directly on to the cloth or leather on the die press. As the cutting of these plates is accomplished largely by hand, their cost is great.

It is occasionally necessary, for small editions, to use zinc plates, made by a photographic process, to stamp the design.



FIG. 21

Zinc being softer than brass, it is less durable, and soon becomes worn, so that the printed design loses sharpness at the edges. Therefore, the designer must embody in his design such a character of line and mass as will not become seriously impaired when these edges become indistinct.

# A · S · V · M · M · E · R · I · N · R · V · R · A · L · E · N · G · L · A · N · D B · Y · R · O · Y · R · A · N · D



FIG. 22

The wear is not so great on the brass dies in high relief, and can be rectified somewhat by grinding down the die after its surface shows the effect of frequent compression; but the relief in the zinc plates is so slight that a new etching is necessary as soon as the wear becomes serious.

For this reason, printed bookcovers must never be executed in fine or delicate lines with the intention of showing fine gradations of shade or softness of detail. Bold conventional forms with large masses properly distributed give the best effect and produce the most durable dies. A design like that shown in Fig. 21 might be very satisfactory for a conventional illustration within the book, but should be reduced to the form shown in Fig. 22 before it will be acceptable for a cover design.

Where a design is executed in more than one color, a separate die is necessary for each color, and a separate printing for each die; therefore, the cost of reproduction is multiplied accordingly. The fewer colors used to produce a good design, other things being equal, the more attractive will be the design to the purchaser, on account of the cheapness of its reproduction.

---

#### PREPARING THE DRAWINGS

**53. Evolution of a Bookcover Design.**—The cartoon, or original drawing, for a bookcover design is submitted to the prospective purchaser as a finished representation of the design itself after it has been applied to the book, whatever may be its cover material. If the volume be an octavo, 6 inches by 9 inches—such as the I. C. S. Reference Library—a piece of paper, canvas, or leather is cut to exactly this size and mounted on heavy cardboard considerably darker in color than the cover itself. This represents the plain bookcover on which the design is to be executed in pen and ink, black and white wash, water color, distemper, or crayon, according to the medium best suited to represent the finished cover. The back of the book (not the reverse cover, but the back on which the title is printed) is laid alongside the cover design in the form of a long strip

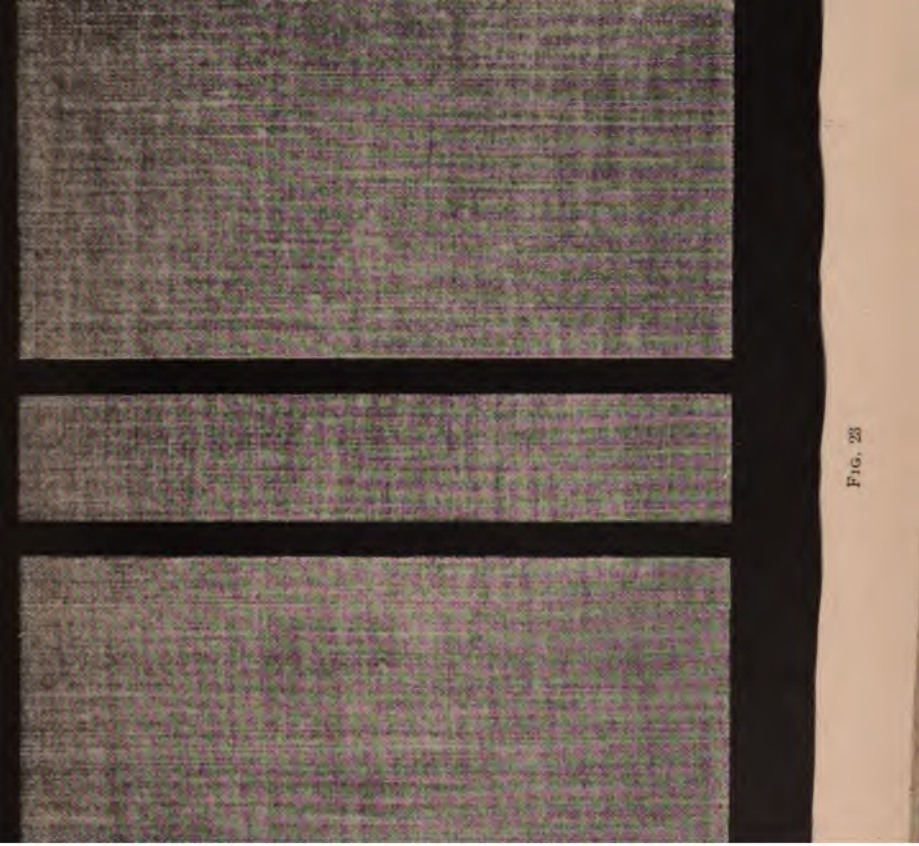

Fig. 23



of paper, cloth, or leather, the exact height of the book and of a width corresponding to its thickness, on which is to be shown the character and distribution of the design on this portion. If the design on the reverse cover of the book is different from that on the front cover, it also is laid out along the side of the book back, as shown in Fig. 23.

With this material cut to the required size and representing the blank form to be decorated, the designer makes a preliminary sketch, full size, of the cartoon, simply feeling for graceful lines, and roughly plotting in the masses. This roughly plotted scheme simply suggests the character of the lines and the proportioning of spaces, as shown in Fig. 24, where the ornament is indicated by a few bold lines, the lettering simply indicated in a blocked space, and the general distribution of the work laid out in pencil on ordinary brown paper or tracing paper, in order to get a pleasing proportion of the design and background. This can then be worked up into general detail with color effects suggested in broad even tones, as shown in Fig. 25, but with no attempt toward the completion of the detail. Having worked this up to the required degree, a piece of tracing paper may be laid over the rough drawing, and the principal features of the design traced from the rough sketch and afterwards carefully and accurately worked up, as shown in the outline pencil drawing, Fig. 26. If the design of the cover be symmetrical, a center line can be drawn from top to bottom and only one-half of the design need be traced on the tracing paper, as this can afterwards be transferred to the other half, forming a completed symmetry. This tracing should be transferred to the blank cover shown in Fig. 23 by means of transfer carbon paper. This can be obtained in several colors, and a tint should be selected that will just show dimly the outlines when transferred on the finished fabric, so that there will be no danger of these outlines becoming obtrusive in the finished cartoon. If the fabric be light in color, such as white paper or light cloth, the tracing itself may be used as a transfer paper if the pencil with which it is executed has been sufficiently soft.

It is best usually to make the letters of the titles on a separate paper and transfer them separately unless the designer is expert in this line of work, and can safely work them out on his original sketch. Having the outline and lettering transferred, the design should be painted in bold flat tints. Where cloth, leather, or heavy paper is the material of the binding, the colors should be Chinese white, distemper, oil color, or gold, according to the circumstances. The edges of the ornament must be clean cut, sharp, and in every respect a representation of what will appear on the finished die, and when the entire cartoon is complete it should be carefully protected by a sheet of thin paper pasted at one edge that will preserve it from injury. Fig. 27 shows the completed cartoon, which is an exact representation of the finished bookcover.

A cover of this character when purchased by the publisher is turned over to the die cutters; they select each color and cut the die therefor without separate drawings, but it is always advisable to submit with the design a table of colors consisting simply of a series of small squares about  $\frac{1}{2}$  inch, each representing an individual color used in the design, so that there can be no mistake as to the number of dies required.

#### DESIGNS FOR ZINC ETCHINGS

**54.** When zinc etchings are to be made for printing on cloth or paper covers, the original design submitted to the publisher is executed in precisely the same manner as where brass dies are the means of reproduction, but the design must be carried further and a separate drawing made for each zinc block that is to produce a color. After the cartoon is complete, the designer must prepare on white bristol board a silhouette of each part of the design that is to be printed in a separate color. These silhouettes should be made about two or three times as large as the reproduced cover demands. Thus, a book 6 inches by 9 inches will require a drawing 12 inches by 18 inches, or larger, in order to get the best results.

To insure accuracy in these plates, a large sized drawing should be made of the entire design, and the section representing each color should be carefully traced, transferred to the bristol-board sheet, outlined, and inked with black drawing ink. In Fig. 28 is shown a bookcover in three colors made with three impressions from zinc plates. The drawing for each of these colors is shown in Figs. 29, 30, and 31, Fig. 29 having been used for the red, Fig. 30 for the buff, and Fig. 31 for the black.

Occasionally where gold is to be used in a design, zinc plates are prepared for it also, but as a gold application requires an exceedingly heavy pressure it is customary to make electrotypes of the plates so that the duplicates can be obtained when the ones in use become worn.

#### PAPER COVERS

**55.** Periodicals, magazines, catalogs, and certain cheaper forms of books are bound in **paper covers**, the printing of which is usually done from zinc plates made from pen-and-ink drawings or block drawings, as above described. Paper covers can also be executed in three-color half tone, which requires simply a photographic reproduction on three plates based on the color theory, and—with a combination of red, yellow, and blue inks—will effect sufficient variation in color to depict any multiple color design. Designs of this character require accurate printing so that the parts represented by two or more colors register exactly. The designer in executing this class of work should bear in mind that as the selection of color values is of a mechanical character, the human eye cannot make a proper analysis of the color combinations without the aid of chemistry. He should execute his designs with the simplest combinations of color possible. Tones that can be effected by a combination of two colors should be used as much as possible, and attempts at great brilliancy or naturalism should be avoided, giving preference to the conventional forms and the flatter tones, to insure good reproduction.

# CATALOG



## POSTER EXHIBITION

TWO HOUR SKETCH CLUB

THE PUBLIC  
PUBLISHED  
1811



# POSTER EXHIBITION

FIG. 29

THE UNIVERSITY OF  
PUBLIC LIBRARY  
APR 19 1965  
YIC 1000



# POSTER EXHIBITION

FIG. 29





FIG. 30

THE NEW YORK  
PUBLIC LIBRARY  
ASTOR LENOX  
TILDEN

Work of the  
ART and  
CRAFTS  
CLUB





THE NEW YORK  
PUBLIC LIBRARY  
ASTOR LENOX  
TILDEN FOUNDATIONS

APR 19 1954  
T. H. M.  
T. H. M.



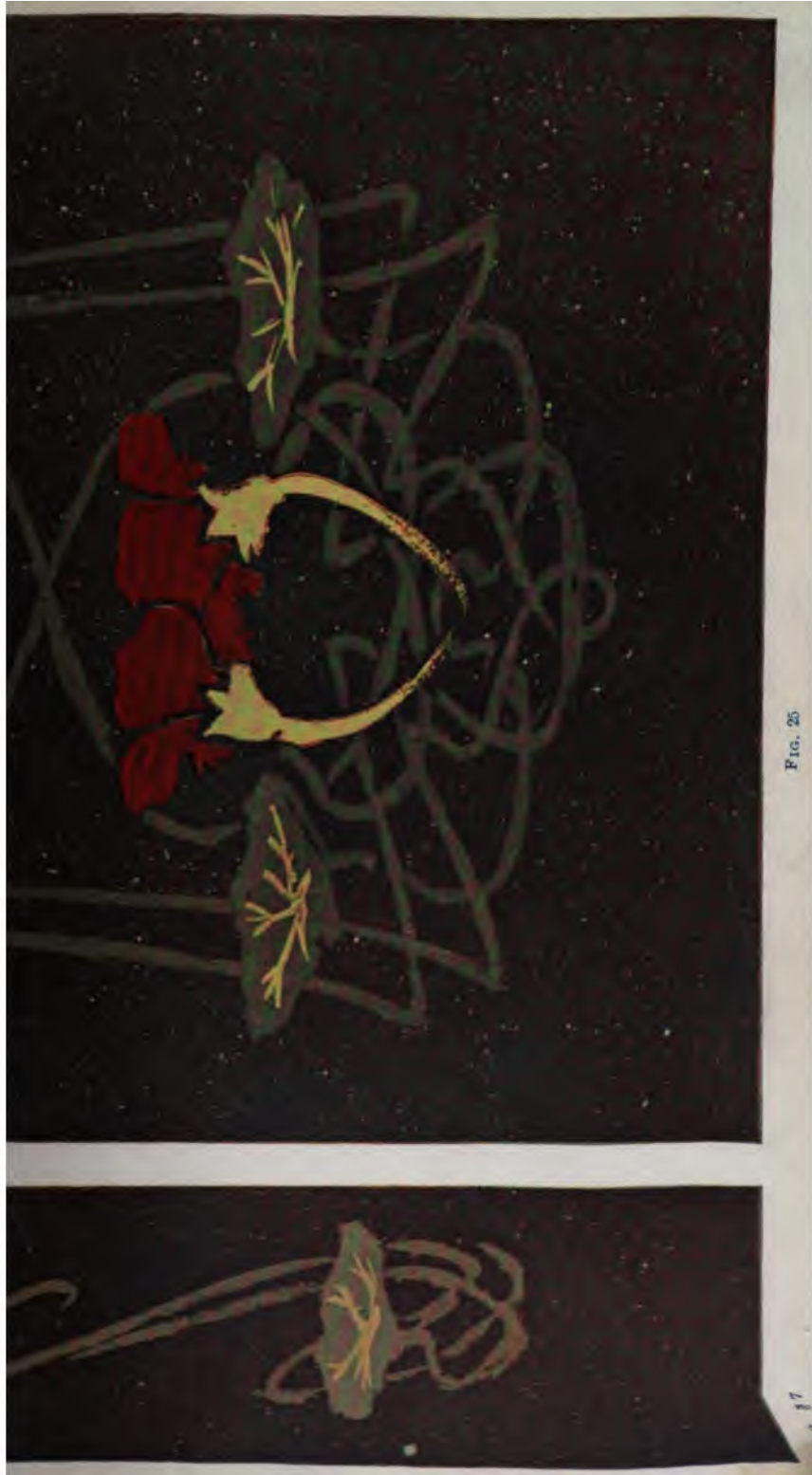
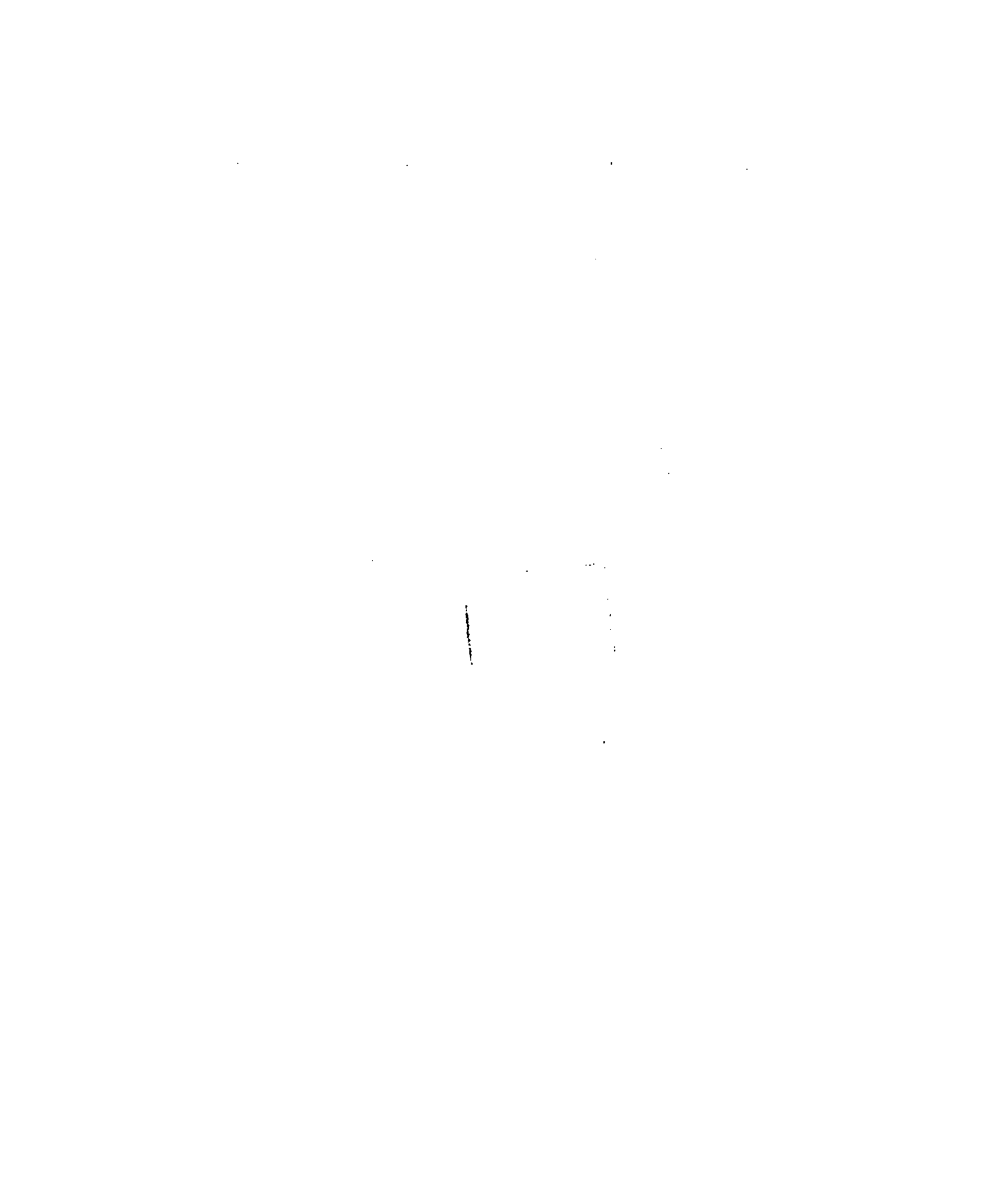

Fig. 25

17





THE NEW YORK  
PUBLIC LIBRARY  
ASTOR LENOX TILDEN FOUNDATION  
1900



*Work of The*  
**ARTS and**  
**CRAFTS**  
**CLUB**

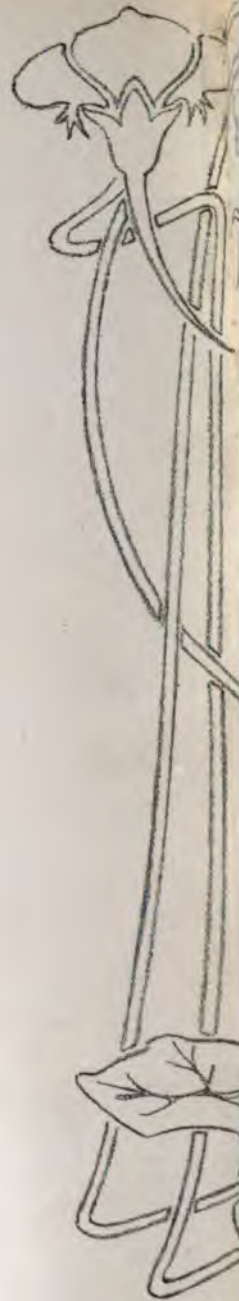



*Work of The*  
ARTS and  
CRAFTS  
CLUB



THE NEW YORK  
PUBLIC LIBRARY  
ASTOR, LENOX  
TILDEN FOUNDATION

THE  
TILDEN  
TILDEN





FIG. 27





# CATALOG



**TWO HOUR SKETCH CLUB**

FIG. 31

8-9

Covers executed in black and white are drawn one and one-half to two times the size of the finished product, in precisely the same manner as illustrations are made for the text. They may include any variety of conventional or naturalistic rendering that may be desired, as the reproduction is absolute and there is no uncertainty as to what the result will be when the plate comes from the photoengraver.

Bookcovers designed in half tone may be made from wash drawings but should be preferably executed in distemper, composed of Chinese white mixed with ivory black to give it depth of color, to which a sufficient amount of Indian red has been added to give it a decided reddish tone. This is of vast importance, as in the process of photoengraving the reddish value in the drawing produces greater contrast than grade values that tend toward blue; a mixture of some inks with Chinese white produces a grade value of a bluish tone that looks perfectly well in the original drawing but reproduces with little contrast. In order to avoid such discrepancies, it is best that all distemper color applied to the shaded drawings possess a decidedly red tone, as there can be no question as to how it will appear in the finished tint.

---

#### REQUISITES IN DOING SUCCESSFUL BOOKCOVER DESIGNING

**56.** The commercial success of the bookcover designer depends on his own individual characteristics and the impression he makes on his prospective purchaser, quite as much as on his skill as a designer and his talent as a draftsman. There is a certain element of egotism in every individual, and the designer must appeal to that element when he submits his cartoon to the publisher. For this reason it is advisable for the designer to come in personal contact with the person in the publishing house that makes the decisions as to what designs shall be used and what shall not be used in the ornamentation of certain books. This acquaintanceship will soon apprise the designer of the character of the work that will appeal to this publisher and he can work up his schemes

accordingly. All designs must be executed with mathematical accuracy, and must be neatly and carefully mounted so as to show them off to the best advantage, as a prospective purchaser will consider the design attractive to the public in the same proportion as it is attractive to himself.

In making a design for any especial title, the designer must not lose sight, in his endeavor to fit the design to the title, of the individuality and attractiveness of the bookcover. The attractiveness of the cover may lead the reading public to study the title after they have been attracted by the design. A glance into a bookstore window where many books are displayed for sale will reveal the fact that there are many designs there that attract attention over and above other designs, not that they are especially beautiful, but are certainly more prominent. If, in addition to this, the design is in harmony with the title and suggests interesting subjects between the covers, it is likely to assist in the sale of the book, and probably appealed to the publisher when he selected it.

The novice in designing should analyze every bookcover and bookcover design that he sees, not with a view to copying the idea, but to the end of learning what was in the designer's mind when he conceived it; also, what there was to it that induced the publisher to use it. This analysis should not only be made from an artistic standpoint, but also from the practical side of the printer, die cutter, photoengraver, and others concerned in its reproduction. An analytical study of this character will also train the inexperienced designer to detect the defects in printing books from old dies, and the deterioration in design due to worn edges on the plates and blocks will be readily observable.

---

#### BOOK PLATES

**57.** A **book plate** is a little device or label executed for the individual owning the books in which it is pasted as an indication of such ownership. The design for a book plate is usually personal in character and is especially suited to the person for whom it is executed.

The book-plate idea is an old custom, but such a one that with the increasing publication of books during the present century it has become very popular. Its origin is somewhat uncertain, but, as suggested hereinbefore, it was probably due to the practice of royal personages who stamped a coat of arms on everything they possessed and thus gave a distinctive character to their particular libraries. In foreign countries, a coat of arms usually forms a part of the device, and the



FIG. 32

book-plate design is frequently transmitted from generation to generation, thus playing a part in family history. In Italy and France, where books were bound in a most costly manner, it was customary to stamp this coat of arms on the outside cover, but in Germany, where the binding was simpler and more substantial, there were no outside marks of distinction and the label was placed within the cover, and so in the early part of the 15th century we find that book

plates had their origin, and it is not unlikely that the first designer of book plates was Albert Durer. A more modern reason for the existence of a particular class of book plates is found in their use as a suggestive hint to borrowers that the book belongs to the individual named.

It is an interesting fact concerning these early book plates that some of them took on a most serious character, while others took suggestive designs or quotations in a lighter vein. The first mission of the book plate is clearly to express ownership, and therefore the modern design should be sufficiently characteristic to remind one at once to whom the book belongs.



FIG. 33

Much criticism has been expressed against the custom of introducing the owner's name in a rebus or sort of puzzle, as in Fig. 38, or of expressing it in a foreign language, or of making quotations relative to the owner's library that are unintelligible to English-speaking persons. This, however, is largely a matter of taste. One's book plate is his own property and may be designed to suit the individual; so long as the design is appropriate it matters not what may be its historic style or language. However, where a book plate is simple in character and contains no characteristic feature to make it distinctive, the owner's name should be conspicuous

and plain. After this consideration comes the question of beauty or interest, which is of equal importance both to the owner and the designer.

**58. General Types of Book Plates.**—Generally speaking, designs can be divided into four general types: the *heraldic*, as in Fig. 32, consisting of crests, designs in armor, and traditional family devices; the *allegorical*, which represents conventionally some symbol or device associated with the individual or his library, Fig. 33; the *conventional*, which introduces a purely decorative idea whose sole purpose is to render the design unique and beautiful, Fig. 34; and the *pictorial*, Fig. 35, which includes designs representing definite ideas associated with the owner or his library, comic situations, or crude representations. The propriety of each class of design to the individual must be judged by the designer, unless direct instructions for the character of the design are given by the owner, and one must bear in mind that these devices, being strictly personal, must be thoroughly appropriate to the books for which they are designed.

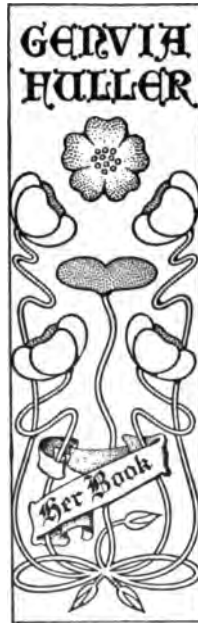

FIG. 34

The character of these books is not limited to their literary standpoint, as the same books in the libraries of different individuals will assume, from the book-plate standpoint, an entirely different character. A rare book of religious character will naturally possess a different character in the library of the religious person than it would in the library of the book collector who made a specialty of collecting rare volumes; to one it is a book of solemn and sacred importance, to the other it is a curiosity forming a part of a collection of curios, and in designing a book plate for either person due



FIG. 35



FIG. 36



consideration would have to be given to the individual rather than to the library.

**59.** Book-plate designs may vary extremely in character according to the books in which they are placed and the persons to whom they belong. In foreign countries where family crests, coats of arms, and other insignia are considered of importance, it is frequently customary to embody



FIG. 37

these in a design. Other book collectors seem to prefer a simple device based on some personal characteristic, and occasionally a simple illustration based on some grotesque idea. A few illustrations of these will serve better to indicate the variety of ideas that contribute to these marks of possession.

In Fig. 36 is shown a reproduction of an engraved book plate based on a heraldic design of the 16th century, while in

Fig. 37 is an 18th century design showing the influence of the rococo style of ornament for the decoration of this period. A more modern English plate is that of Walter Crane, designed by himself, which consists of a pun on his name, shown in Fig. 38, while that of Alma Tadema, the artist, represents an easel in the form of his initials, Fig. 39.



FIG. 38

Fig. 40 was designed for Rider Haggard, the author, and consists of Egyptian hieroglyphs descriptive of his works. In Fig. 35 is shown a book plate, the characteristic feature of which is a detail taken from one of Scott's novels, the scene being associated with Kenilworth. In Fig. 33 is a form of design based on an Egyptian idea and represents an

Egyptian Diety holding separate Superstition and Wisdom, while Fig. 34 is a simple floral design intended purely for



FIG. 39

ornamental purposes and suggesting no allegorical idea whatsoever. The book plate shown in Fig. 41 was designed



FIG. 40

for a lady about to take up her residence in Japan, and was intended for a label for only such books as she might take with her or bring back, the association being entirely with this event. Fig. 34 shows a design based on a conventionalized floral form borrowed from Fig. 10, *Plant Analysis*. Fig. 42 shows an adaptation of the conventionalized dandelion arranged to fill the space and render ornamental what would otherwise be a simple label. These designs are

introduced here to show the application of ideas derived from natural forms to simple design purposes.

Thus it will be seen that, while the book plate is personal in character, it does not necessarily partake of any distinct individuality that applies exclusively to one individual. While a similarity of book plates may be accidental, it does not necessarily follow that one is more unsuitable to its



FIG. 41



FIG. 42

purpose than another, simply because in the mind of the observer its direct relation to the owner cannot be determined. In the majority of cases, the owner himself is the best judge of the suitability of the book plate, and while the artist may find it necessary to submit a number of sketches in order to get the owner's ideas, the latter is always to be the judge of what is to be preferred.

#### STYLE OF RENDERING

**60.** Like every other class of design, book plates should be rendered in the medium and method best suited to each individual case. The majority of them are probably etchings on zinc from pen-and-ink drawings printed in plain black on a white label. Exceptions to this rule may arise by the introduction of two or more colors (as was the case in Figs. 34 and 42 where the conventional leaf forms were printed in green), and in certain individual instances where a three-color half tone might be used, or even the lithograph, to represent the design in many colors. The method of drawing for zinc work is precisely the same as that for general illustrating or for paper bookcovers. Certain conditions may demand that the design should be conventionally rendered, but no attempt at pictorial detail or local shading, similar to Figs. 21 and 35, should be made, but a pictorial rendering like that shown in Fig. 22 is perfectly proper when circumstances demand it.

Simplicity should always be borne in mind as the most desirable characteristic in the rendering, and the simplest method of rendering a chosen design is always the best. Designs that are to be reproduced in half tone should, in nearly all cases, be severely conventional, as the soft effects obtained by this method of reproduction are likely to render a pictorial effect so soft that it is not well suited to so utilitarian a purpose as a label.

---

#### LETTERING

**61.** In all classes of bookcover, book-plate, and poster designs too much care cannot be given to the subject of lettering. A mistaken idea prevails in the minds of many artists that so long as the general design is well conceived and executed, the lettering is of secondary importance, and other still less experienced people incline to the belief that better lettering can be supplied by the printer than can be drawn by the artist. All this is decidedly wrong; in many

respects the lettering is the most important part of the design—at least if it is so considered there will be little danger of the artist falling short in this particular. It should be borne in mind that the essential feature in the book-cover, book plate, or poster is usually the purpose for which it is made and the subject that it represents, and this is expressed in the printed matter impressed on it. This, if for no other reason, should settle the question of the inadvisability of careless lettering. The arranging, proportioning, and spacing of letters in a design should be as much the subject of study as the distribution of any other ornament, and after it is generally sketched in it should be carefully outlined and worked up to the last detail.

Letters that appear in the finished print to be carelessly or sketchily rendered are usually the result of greater care than those that are exact and uniform. Original ideas in letter forms require particular attention in order that their parts may be balanced well, and in many cases it is far better to exaggerate the characteristics of a letter in the direction that it ought to go than it is to fall short in the slightest degree in the proper proportioning. Take ordinary printed letters, for example such letters as B, E, and S in the capitals, and while they appear to be exactly uniform at top and bottom, it may be easily discerned by turning the print upside down that the lower portion of the letter is considerably larger than the top, and by an experiment in drawing one readily learns that to proportion one of these letters exactly symmetrical so as to make its top and bottom equal in size gives it a top-heavy appearance that is very unsatisfactory. This defect is not so prominent in the lower-case letters, but a common error here is to make the stroke of the d and t quite as high as those of the other long letters, thereby throwing them out of proportion. It is well, however, in all cases not to make the lower-case letters perfectly circular or elliptical, but rather to give the round ones an oval shape with the larger portion at the bottom. In lower-case letters like the French Roman and the Medieval Roman alphabets this peculiarity is very marked. The

lower portion of the c, e, o, etc. is considerably wider than the upper portion, and in the letter s this particular is strongly emphasized.

It is found desirable in many cases to give a careless or artistic effect to the rendering of the letter so as to detract from it the appearance of having been rendered mechanically. The novice is inclined to the belief that this appearance is given to it by actual carelessness in the drawing, whereas, as a matter of fact, more skill is required in the rendering of this style of letter than of one that is perfectly clean cut in its outline. For bookcover work it is better that all rendering should be freehand, including both the lettering and the ornament, except in such instances where a decidedly stiff and mechanical appearance is intended, and to render this effect most forcibly each letter should be carefully outlined with a pen and the solid portions filled in with a coarser pen or a fine brush. This method of outlining serves the double purpose of producing a clean even edge to the finished letter and of enabling the designer to preserve a uniformity of width in the stems and strokes that can be better judged when these details are in outline than when they are drawn solid.

While the designer may exercise the greatest liberty in the choice, style, and formation of letters, in order to design original lettering he should study the characteristics of the simple alphabets. A thorough knowledge of the proportions of the light antique Egyptian and the Medieval and light French Roman should enable him to design other letters in accordance with the proper proportions without in any way indicating that he copied some certain style.

**62.** A standard style may be varied somewhat without in any way destroying its individuality. For instance, the light antique Egyptian may be extended or contracted so that the same height of letter may fill a longer or shorter space. This will change the slant of the sides of the A, W, and V, but in the letters H and M the extension may be effected by inclining the sides somewhat, thereby preventing a squatty

appearance to the letter. In the letter N, the left stroke only should be inclined in order to preserve the appearance of stability. The details of this alphabet may also be somewhat exaggerated; the horizontal strokes of the A, E, F, and H may be raised or lowered considerably where it is desired to severely conventionalize the letter, and the upper loop of the B, P, and R may be materially diminished in height. The same liberties may be taken with the light French Roman but with less freedom, while the Medieval Roman is best kept in its standard form without alteration.

The Gothic alphabet offers the greatest opportunities for variation of any, while at the same time it is one of the most severely conventional. The left stroke of the A, terminating as it does in a large disk, may be carried still lower and under the right stroke with perfect propriety. In a similar manner, the curved stroke of the H may be swept under the vertical stroke, and the J may be constructed with a vertical stem similar to the I. The W is often designed as an inverted M, and the U as a symmetrical letter, both of its sides similar to the curved stroke in the W. The T is frequently drawn with a vertical stroke and horizontal cross-piece similar to the upper part of the letter F, while the Y may partake of the same characteristics as the U and V when it occurs in the same lettering.

Whatever is done in the way of lettering should be done with the greatest accuracy and care, as no design, no matter how well executed, can be accepted by a careful purchaser if the lettering is not as carefully thought out as the rest of the motive.





# CARPET DESIGNING

---

## BRUSSELS AND WILTON CARPETS

---

### INTRODUCTION

1. When one has acquired the theoretical idea of the application of natural forms to design, it is necessary that he should understand the mechanical limitations of certain forms of machinery or methods of production in order to fit himself to design for some specific purpose. The preparation of a design for a carpet or other woven fabric differs in no way from the preparation of a design for a piece of silverware, except so far as the mechanical limitations of the methods of reproduction are concerned. Both may be based on the same natural type severely conventionalized to suit the material and the machinery that are to produce the result, and the more intimate the designer is with the limitations of these methods of production, the better and more economical can he design for some specific purpose.

Many of the most practical carpet designers learn their craft while helpers in the designing room of a factory, and although this is an admirable way of acquiring the practical experience necessary to a good design, it has the disadvantage of being a tedious process, as manufacturers are usually slow in recognizing the artistic ability of employes occupying subordinate positions. A man with original ideas and ability as a draftsman and designer can train himself, in a few months, to occupy the position of a first-class carpet designer by studying mechanical limitations of a certain kind of manufacture. The helper in the design room

COPYRIGHTED BY INTERNATIONAL TEXTBOOK COMPANY. ALL RIGHTS RESERVED

learns only the practical side and is kept copying the ideas of others, so that his own individuality is never expressed. He soon becomes a mere machine, and therefore is in the worst possible condition to become a successful designer.

The head of such a designing department usually is a graduate of a technical school, and he is apt to keep to himself much of the theory of design and at the same time make little effort to absorb the practical side from his helper.

The public designer, however, must understand both the theoretical and practical side. He must thoroughly understand his craft, possess inventive genius, and thoroughly understand the practical and economical sides of mill work in the production of his fabrics.

**2. Wilton and Brussels carpets** are so closely related in structure that they may be considered as one, the designs being made for each in exactly the same manner. They are manufactured in several grades and called by various names, but in the mills and in the wholesale trade are usually designated as *five-frame*, *four-frame*, or *three-frame*, depending on their coloring. These terms must be thoroughly understood, as they not only govern the color combinations in the carpet, but also, to a certain extent, the quality.

A careful examination of the back of Brussels or Wilton carpet will show that it is composed of a harsh fabric of linen, cotton, or other inferior material, the smaller threads intersecting the heavier ones at right angles and forming little squares exactly corresponding to those on the design paper. The threads running across the carpet are the *weft*; each is inserted in its place by 1 *pick* on the loom or one trip of the shuttle across the warp. The heavier threads running lengthwise of the carpet are the *warp threads* or the *ends*. Three of these are within each small square visible on the back of the carpet; two, called *chain warps*, form the thin longitudinal lines of the square, while the third and thicker one, called the *stuffing warp*, fills the mesh left by the section of the chain warps and the weft. This stuffing warp helps to give solidity and stability to the fabric. Besides

these warps, there are observable bits of colored worsted yarn that have been crowded through the backing. These worsted yarns are run lengthwise of the ends and are therefore warp threads, and it is their loops that are brought to the surface of the carpet to produce the pattern.

**3. Rules.**—In weaving body Brussels, a plain wire **rule** is inserted under the pile warp at each pick, which, when pulled out, leaves the loops as woven. In Wilton carpet, however, the end of the wire is sharpened so as to form a projecting knife blade, which, when drawn out of the loop, cuts their tops and leaves a soft velvet-like effect.

The loop of the Wilton carpet is larger, or higher, than that of the Brussels; therefore, the Wilton carpet contains a larger percentage of worsted and is proportionately more expensive. But the cut loop and the greater percentage of worsted required by the difference in length of the loop are the only differences between Brussels and Wilton carpet.

All the warp threads are fed into the loom from the back, the chain loops are wound on one large reel, called a *beam*, and the stuffing warp wound on another reel or beam. The colored warps forming the face of the goods, usually termed the *pile warp*, are wound on separate bobbins or spools.

**4. Design Paper.**—Designs for all woven fabrics are rendered on a squared paper, such as shown in Fig. 1, which is a full size section of a piece of **design paper** used for the designing of Brussels carpet.

The weaver, in reproducing his design on the loom, must have before him a working drawing, or diagram, that can be easily translated on his loom, by means of a pattern-controlling mechanism, into a design in carpet. Every line of squares lengthwise of the paper represents one or more of the warp threads, which run lengthwise of the fabric and are termed *ends*; while each line of squares across the paper represents a weft thread, which runs across the fabric and is termed a *pick*. In this Section the term *pick* will always refer to a single cross-thread and the term *end* to a single warp thread.

The design paper, when purchased by the designer, is usually in *cloth size*, that is to say, it is full size, the design on the paper being the same size as the design on the finished fabric. Cloth size for Brussels and Wilton carpet is 27 inches ( $\frac{3}{4}$  yard) wide, and as in Brussels carpet there are 8 ends to the inch; the full width of the carpet contains 216 ends. The length of the paper varies, as it is governed

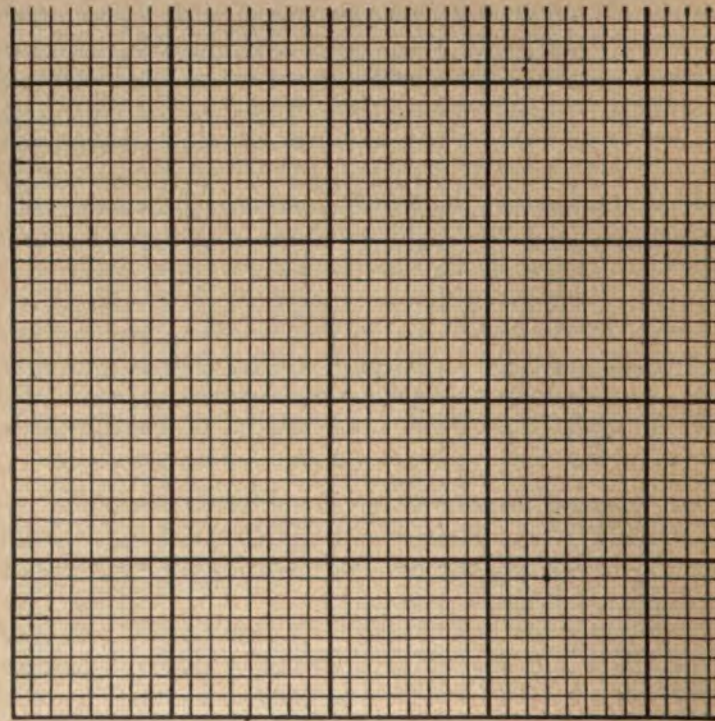
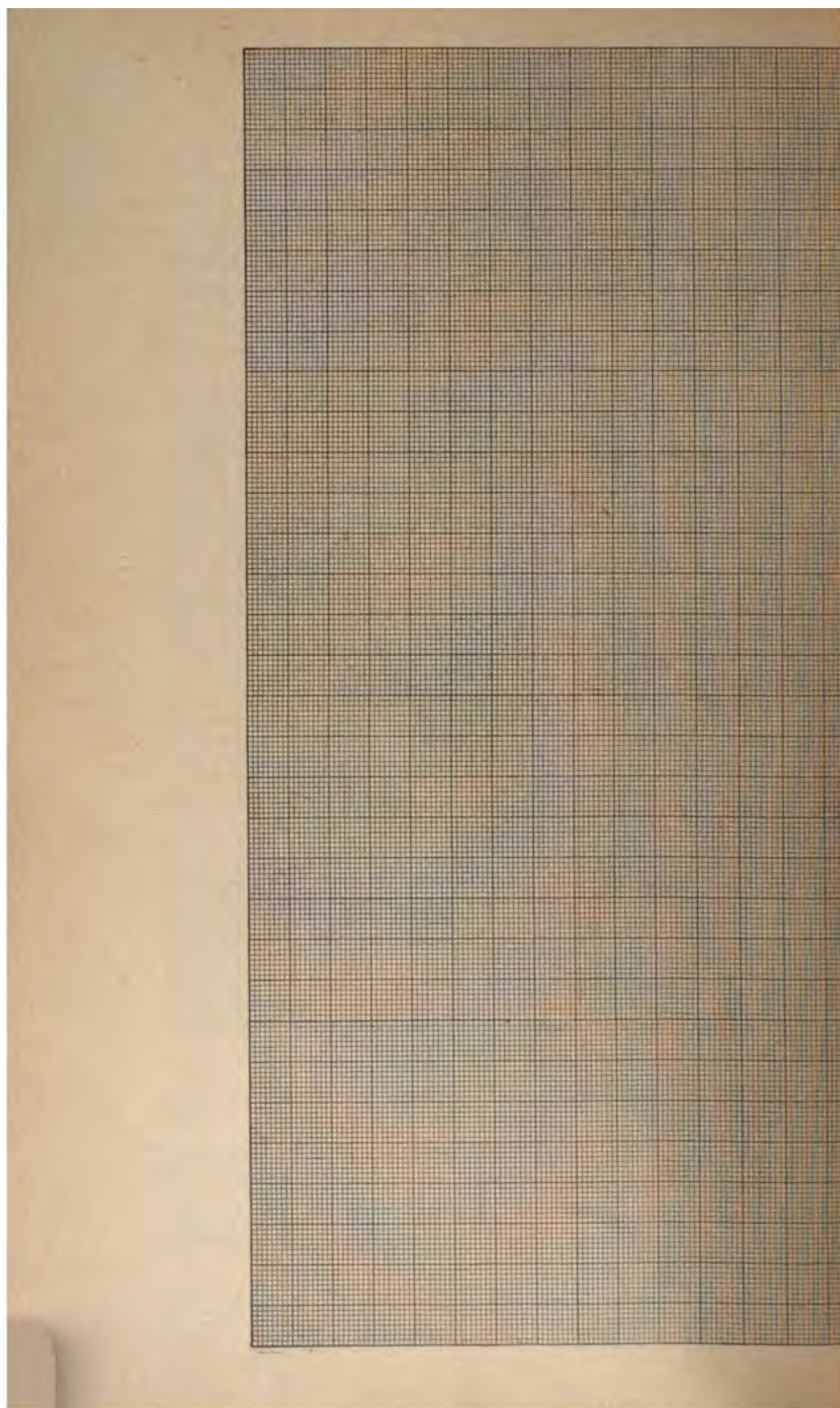
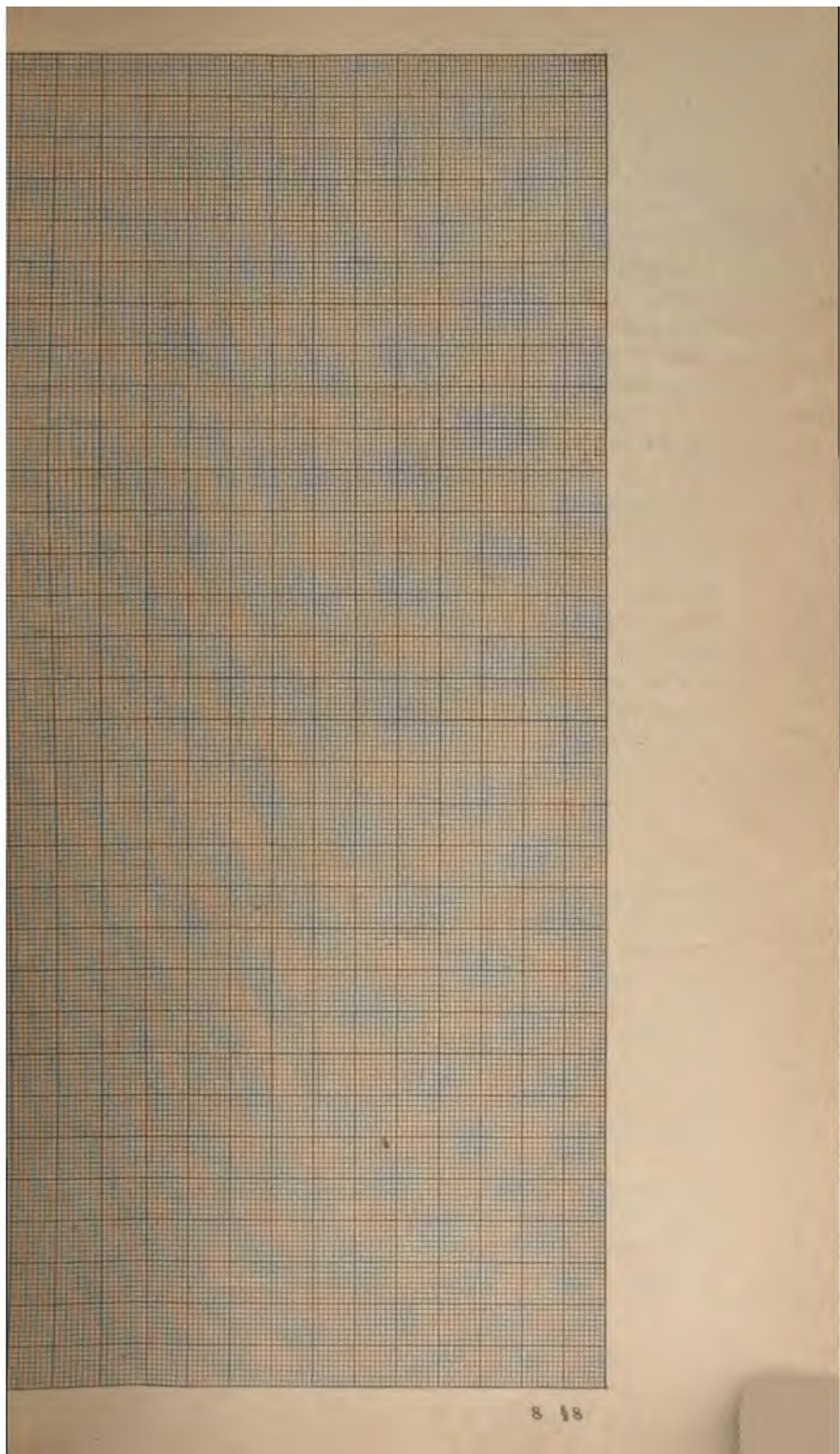

FIG. 1

by the length of the repeat. The squares are grouped into larger squares, each of which is known as a design, and a pattern in which the repeat is based on a 27-inch square, as in Fig. 2, is known as a 32 design wide by 32 design long. Each of these designs is divided into 64 smaller squares; these small squares are the ones that are of most

Y  
100









practical use to the designer and to the weaver; the larger ones are emphasized simply to enable the designer to count the smaller ones better in spaces divided accordingly. Multiplying 32 designs in width by 8, the number of squares in each design, we have 256 small squares in the width of the paper, which corresponds with the number of loops placed side by side in the standard width of Brussels carpet.

Each square in the design paper, therefore, corresponds to one loop of thread in the pile of warp that comes to the surface of the loom and forms the carpet. In other words, each row of squares across the carpet represents 1 pick. The fineness or coarseness of the pick depends on the number of picks to the inch, ordinary Brussels carpet being made with 9 picks to the inch, while exceedingly fine carpet has as many as 13. As each pick appears as a row of loops, the various colored yarns brought to the surface unite to form the pattern or design, and it is therefore evident that each square on the design paper must be accounted for by the designer to the weaver, so that the loom may be arranged to bring to the surface at the proper point the proper color of yarn.

---

#### DESIGNING

5. The experienced designer usually roughs out his sketch directly on the design paper, using for this purpose charcoal or crayon and, at the beginning, giving no heed whatsoever to cross-sections or squares. Long sinuous curves with free open drawing indicate the general trend of the main features of the design, and finely drawn details are worked up afterwards. In doing this, the designer never loses sight of the fact that in his completed work the lines and figures must be represented by a series of checkers, and he instinctively avoids such geometrical forms as are too minute to be boldly expressed in this manner. Long delicate curves extending in a horizontal direction are impossible, as they must necessarily be made up by a series of long straight lines separated from each other just 1 pick; bold decided curves, however, may be

drawn in almost any direction. In Fig. 3 are shown examples of both good and bad renderings of curves, which serve well to illustrate this point. On one side are shown the outlines of the forms that are to be represented, while on the other side are the results of these curves worked out on the squares.



FIG. 3

After the figures are drawn in with charcoal, the design is **ticked in**; this consists of indicating, by little spots of color, what areas are to be filled in with the different colors. The color scheme of the design must be decided on beforehand and the figures carefully outlined, and the color of each indicated by a touch of the proper tint. The experienced

designer will make use of the checker effect to get the best possible drawing.

Different designers use different methods of starting the work, and each student must determine for himself, after some practice, which method will best attain the proper results. Some designers carefully draw out the figures, in pencil, before filling in with color; others start in with the color and "feel" for a pattern and the color scheme at the same time. In Fig. 4 is shown a design commenced in this manner; the main figures have been "roughed out" in charcoal and afterwards ticked in with dark blue; then the different areas are filled in roughly with the local color. These trial color areas should be washed in with thin color so that the ruled lines are not obliterated, and the colors can then be altered without the application of two coats of the heavier opaque color, which would be likely to chip off if the design were much handled.

The figures drawn in outline on the design paper are likely to appear much more perfect than when filled in with color; therefore, it is advisable to "rough in" the general design in color as it brings to light at once any bad drafting and gives the designer an opportunity to remedy this defect before it is too late.

In the factory, where the busy designer has a number of helpers, he would not carry his design quite as far as is shown in Fig. 4, but after roughing it out would hand it over to the helper, trusting to him to carry out the effect and color scheme that he has indicated by ticking in.

For *ticking in* and "*putting on*," it is well to use old or worn red sable brushes, or new ones whose points have been purposely cut off, or burnt off by touching them to a red-hot iron, to fit the size of the checks.

The use of large squares in the design can be observed in the bold treatment of the pattern shown in Fig. 4, as the designer can here tick in only one-half of each of the figures so that a helper can reproduce the other side by counting the squares. The beginner, however, must learn to carry out his entire pattern from start to finish in general scheme,

as shown in Fig. 4, and to finish it up himself. The length of the repeat in Fig. 4 is 27 inches, the pattern being a drop repeat, and the large figure drawn in the center with a repetition of one-quarter of it at each corner is 27 inches square. There are five colors intended, as shown in the illustration.

**6. The Problem of Color.**—To the designer of Brussels and Wilton carpets, the problem of color is of the greatest importance.

The colored yarns are brought to the surface where required by means of the Jacquard machine, which governs each end of warp yarn. The proper colors are raised at each pick to allow the passage of the shuttle carrying the weft thread, and the insertion of the wire rule over which a loop of the particular color is formed. The insertion and withdrawal of the wires is performed automatically by the loom by means of a contrivance called the **wire motion**.

**7. Frames.**—The spools of worsted are inserted in racks, called **frames**, a separate frame being required for each color or set of pile warp threads. Fig. 4 shows a design for a five-frame Brussels or Wilton carpet. Any of the five colors—red, gold, sage, dark blue, and ecru—that appear throughout the width, can be traced so that it will be found somewhere in the repeat to occupy each of the 256 squares that extend across the ruled paper. If this carpet were woven in only one color, it would require 256 warp threads of this color to be wound at the back of the loom; this would make one full frame, as each frame contains 256 bobbins, holding 256 pile warp threads. As these warp threads are consumed in the weaving with unequal rapidity, according to the frequency with which the different threads are drawn to the surface to form the pattern, it is impracticable to wind them all on one big bobbin or beam. The pattern shown in Fig. 4, however, calls for five colors; therefore, we must have a frame with 256 bobbins on it for each individual color. A five-frame Brussels carpet, therefore, has  $5 \times 256 = 1,280$  colored warp threads fed into the

fabric constantly at the back of the loom. At each pick, 256 ends of warp thread are raised and a wire thrust under; then the weft thread binds them into place and 1 pick of the pattern is formed. The remaining 1,024 colored warp yarns are hidden and lie idly in the body of the pattern, giving this carpet the name of *body Brussels*.

This is the principle of the five-frame weave; the four-frame weave requires  $4 \times 256 = 1,024$  ends, and the three-frame, 768 ends, etc. Thus we see that the five-frame carpet has 256 more ends of warp in its body than a four-frame, and 512 more ends than a three-frame. It is evident, then, that the former is much heavier and contains much more material than the latter, and is therefore costlier, regardless of the character of the pattern.

As far as the simple process of weave is concerned, each one of the 1,280 strands in the five-frame carpet could be a different shade, but the color effect in such a case could not be conceived, as there would be simply a blending of all in one. Where each frame contains a different color, as in Fig. 5, the pattern can be formed by bringing the colored warps to the surface in different quantities and having them distributed on different spools, according to the quantities in which they are required.

**8. Planting.**—This does not necessarily restrict the designer to the employment of the same number of colors in his pattern as the number of frames in his loom, and on this variation of the color scheme depends the important details of the design. The designer's ingenuity is taxed to produce the best arrangement of comparatively few colors to produce the best results. The designer may use six or seven colors in a five-frame fabric, but to do this he must make use of the system known as **planting**, which means the introduction of two or more colors in one frame so that each will contribute its share to the fabric without interfering one with another. Each of the five frames could be a planted frame if desired, but as a rule three or four of the frames are **run full** in solid color and the remainder are planted.

It is necessary for the designer to arrange below his design the plant or gamut of colors, showing exactly how many ends of each color is used in each frame, as shown in Fig. 5. The plant is laid out on a separate strip of paper, and as the colors are painted in on the design they are arranged in their proper places on the plant, so that when this plant is submitted to the weaver he is able to arrange his bobbins on the frames accordingly.

In Fig. 5, the design contains eight colors—black, red, dark gold, green, green-blue, pink, light gold, and ecru. The only full frames are the black and red, as shown by the solid lines across the plant. The dark gold is somewhat less than a full frame, 16 ends being vacant, as shown at (*a*). The green-blue is planted with green in the next frame but this is not full, 16 ends being vacant at (*b*), 12 at (*c*), and 13 at (*d*). In the next frame, the pink and the light gold are planted, 3 ends being vacant at (*e*), 16 at (*f*), and 25 at (*g*). In the five frames 102 vacant ends are shown, but as this example shows only one-half of the design, there would be 204 vacant ends altogether.

Should this carpet be woven with the seven colors mentioned, omitting the ecru, it would not be a full five-frame value, although five frames were used; therefore, a sixth frame is introduced in which a sufficient number of ends of ecru are used to make up for the missing ends in the other frames, namely, 102 in this half pattern or 204 in the full width.

This would make a six-frame fabric so far as the weaving is concerned, but only a five-frame fabric so far as the finishing part of it is concerned. Thus you see that the designer left 204 vacant ends in the width of his design so that he could finally introduce an extra color, and a tracing of the ends as they extend through the pattern would easily illustrate how these colors have been balanced and worked out.

**9. Planted designs** possess mechanical limitations that must be understood by the designer. One cannot bring out a planted color throughout the design at any place he

chooses, as he can with the color from a full frame. Planted colors exist in those ends only in front of which they are placed, and they cannot be brought up in the design where these ends do not pass. For it can be seen that the planted warp threads exist in the fabric as a series of longitudinal stripes, and the order of these stripes cannot be disarranged to bring the colors to the surface elsewhere. The designer must, therefore, keep this limitation in mind and exercise care and ingenuity not to reproduce a distinctly striped effect. An ingenious designer will so arrange his figures and distribute his colors that the finished design will give no indication of the fact that the colors have been planted. The employment of planted colors in Brussels carpet is sometimes referred to as *chintzing*, and it is possible to make every one of the 256 bobbins a different color.

While it is never necessary that every bobbin should carry a different colored yarn, the fact that such can be the case enables us to make a kind of pattern known as the chintzing pattern, where natural floral forms are woven with some attempt to reproduce their effects in color, light and shade, etc., as shown in Fig. 8. This involves the fullest knowledge and ability in making planted designs, as a great variety of colors in the different forms of ornament and effects of shading in the color is produced by arranging, side by side, various tones in the same frame. A flower can thus be produced with four or five tones of yellow, where beside it you will find one with several tones of blue, and another in red, etc.

These colors run in line from the top to the bottom of the floral design, variety being possible only laterally; thus, flowers coming in the same vertical line can be alike in color. Small sections of color can be brought to the surface from other frames and form accents to strengthen the drawing, to break up large masses, and otherwise improve the general effect, and there are endless opportunities and possibilities in this connection wherein the designer can exercise his ingenuity and skill.



**10.** In Fig. 6 is another example of planting where the red, blue, sage, and ecru, and the three tones of dark brown have been introduced in the pattern, making the total number of colors seven. It will be observed, too, that neither the red nor the ecru extend over the full width of the border. All the middle tone of the brown is planted with red, but by carefully observing one can see that nowhere in the pattern do these colors come in the same vertical line. All the dark brown that appears on the outer edge of the border between (*a*) and (*b*) is planted with the red, and all the dark brown between (*b*) and (*c*) is planted in blue, while that which refers to the inner edge of the pattern is planted with the ecru. We thus have planting of one color on three frames, the dark brown existing with the red, blue, and ecru.

**11.** For a beginner, the five-frame plan of design affords a problem of sufficient difficulty, and he should not concern himself with planting colors until he acquires a thorough working knowledge of the changes that can be effectuated in five-frame designs.

Here, he must not only employ five colors, but he must employ them in such a manner that the best effect can be obtained in their proper combination. If, in working on the five-frame plan, only four colors appear with prominence, and the fifth color comes to the surface in isolated spots, it is evident that there are many ends on the fifth frame that are being woven into the carpet without doing any service other than to add to its body. Under such conditions the designer would be producing only a  $4\frac{1}{2}$ -frame effect while giving a five-frame quality, and his design would therefore be considered defective, as he is not getting the most from his five frames.

**12. Standard Repeats.**—The usual standard for a repeat in Brussels and Wilton carpets is 27 inches, although carpets are woven a full yard in width for stairs and halls. Stair carpets are occasionally woven with two side borders and a filling, while the same border is sometimes woven separately to be attached to the regular hall carpet designed to match the filling of the stairs.

Stair carpets are also made in widths of  $\frac{1}{2}$  and  $\frac{5}{8}$  yard, with borders to match, and the fillings are woven in various widths, such as  $\frac{3}{8}$ ,  $\frac{1}{2}$ , and  $\frac{5}{8}$  yard. The border shown in Fig. 6 is woven on 216 ends, making it about  $\frac{5}{8}$  yard wide when executed on  $8 \times 8$  paper. In length, it repeats once in 128 picks, or  $\frac{3}{4}$  yard, but the same design can be extended to 256 picks by changing the color arrangement in the large figures alternately, thus giving it a repeat of  $\frac{3}{4}$  yard. Repeats can be woven in various lengths up to  $1\frac{1}{2}$  yards, under which conditions very broad and bold effects may be obtained.

A long repeat is usually arranged on a drop pattern, so that there may not be too much waste in getting the goods to match properly when a carpet is fitted.

A small pattern that is so designed that it cannot be matched in less than a yard is an unprofitable design for the retail dealer to carry, and a thoughtful designer must take this into consideration, as it is likely to prevent the disposal of his design. Such designs have been made by thoughtless designers and manufactured by unobserving manufacturers, and often have been sold to retail dealers, the defect remaining unknown until the cutter would endeavor to fit a room, when he would find that a yard or more in each length would have to be wasted in order to secure a satisfactory repeat.

**13. Designing Carpets That May Be Formed Into Rugs.**—Carpets are frequently made in patterns that are to establish uniformly sized rugs. The usual sizes of Brussels rugs are 6 feet by 9 feet, 8 feet 3 inches by 10 feet 6 inches, and 9 feet by 12 feet. Wilton rugs are made in the same sizes, as well as 36 inches by 63 inches, 36 inches by 72 inches. One style of Wilton rugs, known as *hall runners*, are 3 feet by 9 feet, 3 feet by 12 feet, and 3 feet by 15 feet. A Brussels or Wilton rug, 9 feet by 12 feet, is made up of four strips, each 12 feet long and 27 inches wide, which are sewed together. The two outer strips contain the side border and its return on the corner, and usually a part of the filling, unless the border is 27 inches wide. The two

inner strips finish out the borders across the ends and also the fillings.

In designing a rug of this character, the designer must prepare his design for one-quarter of the entire space, which will require four sheets of cloth-sized paper. The width of the design will contain 512 ends, an equivalent of  $1\frac{1}{2}$  yards, while the length will include 648 picks at 9 picks to the inch, or 72 inches. Thus, one-half of the length and one-half of the width of the rug is expressed in the design, and the duplication of these details is effected through the mechanical devices in the loom. The designer need not concern himself about this detail, however, but must arrange his design in such a manner that the figures expressed in the rug will turn over and match properly. The design is usually executed at the lower left-hand corner of the rug, and the four pieces of paper are laid out as though they were one sheet, the proper number of ends and picks being accurately accounted for.

**14.** As it is desirable that rugs of this character should appear as if made of one piece, rather than of several pieces sewed together, the skilful designer schemes out his pattern so that the seams are hidden as much as possible. The first seam passes directly through the center of the drawing and can be used as a center line on which the figures duplicate or repeat to form the symmetrical devices on each side. If a 27-inch border is used, this seam can be hidden by the line of the border itself where it unites with the rug. A small wandering all-over pattern is most effectual for hiding the seam where it is desired that it should be suppressed, and a plain ground or filling is most likely to bring it into prominence. Where a plain ground is desired in the rug, as a whole or in a portion of the border, it is best that some of the design should extend beyond the seam at the end of the rug where the side borders and end borders unite, as the most objectionable place for the seam to show itself is at this point.

Designs for rugs smaller than 9 feet by 12 feet are adapted from the 9 ft.  $\times$  12 ft. pattern. In rugs 8 feet 3 inches

by 10 feet 6 inches, the two outside strips are  $\frac{5}{8}$  yard instead of  $\frac{3}{4}$  yard, making a reduction of  $4\frac{1}{2}$  inches from the previous border from each side of the rug, or 9 inches in the entire width. If the pattern permits, this diminution in size is removed from the filling of the rug and the border is left as it was originally designed for the 9 ft.  $\times$  12 ft. size.

Sometimes a border is composed of a number of subdivisions, so that when the smaller rug is prepared one of the subdivisions is omitted from the border, thus making it narrow. The two middle widths for the filling of the rug are left  $\frac{3}{4}$  yard wide, and the length is reduced by dropping  $\frac{1}{4}$  yard from the filling; though, if  $4\frac{1}{2}$  inches has been dropped from the border, only  $4\frac{1}{2}$  inches need be dropped from the filling.

In the next smaller size, 6 feet by 9 feet, the side strips are  $\frac{5}{8}$  yard in width and the length is reduced an even yard. In making these corrections, care should be taken that no redesigning is necessary, as much trouble and expense can be saved by the observance of this rule.

**15. Forming New Patterns.**—Occasionally it becomes necessary that an entirely new pattern be drawn, but this rarely involves more trouble than the copying of the original design, with the omission of certain details and the alteration of others.

This practice of redrafting a design does not require the skill and experience of the head designer, but its easy accomplishment can be effectuated only through the forethought of the head designer in the planning of the original 9 ft.  $\times$  12 ft. rug. In this he has given due consideration to the separate sizes and has planned his border and filling so they can be cut down to the standard sizes without materially detracting from the general effect of the design.

In redesigning or redrawing the smaller sizes, it is nearly always necessary that there should be a reduction in the scale of the ornament, and as the beginner is likely to omit much of the detail in order to effect this reduction, the work requires the services of a more experienced man than does

the reducing of the larger sizes. In this work the designer should be able to reproduce the original design on a smaller scale without losing the general effect and general appearance of the original.

The hall runners and other 1-yard-wide sizes are usually woven in one piece and are executed on the design paper accordingly. The 9 ft. × 12 ft. rugs have been woven in one piece also, but they are very expensive and have not as yet come into general use.

**16. Popular Designs.**—The most popular designs for rugs at the present time are oriental patterns, which have succeeded entirely the floral patterns that were so popular a few years ago. Many of the latest carpet designs are deliberate copies of oriental rugs that have been rendered from high-priced originals and reduced to mechanical methods of weaving without losing the color effect and general appearance of the original. The machine-woven carpets can never compete closely with the hand-made article of the Orient, as they are bound to be lacking in that charm and variety of color that is characteristic of oriental rugs. Skilful designers, however, by the careful planting of colors, succeed in obtaining a richness of effect that is strongly suggestive of oriental motives. This is usually effected by using a number of colors that are equal in tone but different in color, the amount of difference in color varying with the design, some being widely different while others are only slightly different. Good effects have been produced by introducing green and bluish gray in the same frame, and also green and blue with very little or no contrast of tone. Some patterns produce a pleasing effect by the introduction of a very small quantity of bluish green in order to break the monotony of the background of a rather warmer green.

The most popular carpets at the present time are those in bright oriental colorings, such as that shown in Fig. 7, rich reds, deep blues, and gold being the most prominent in this scheme, while small quantities of green, turquoise, pink, ecru, orange, yellow, white, and black are introduced to give

YOUNG  
PUBLICATIONS  
1957

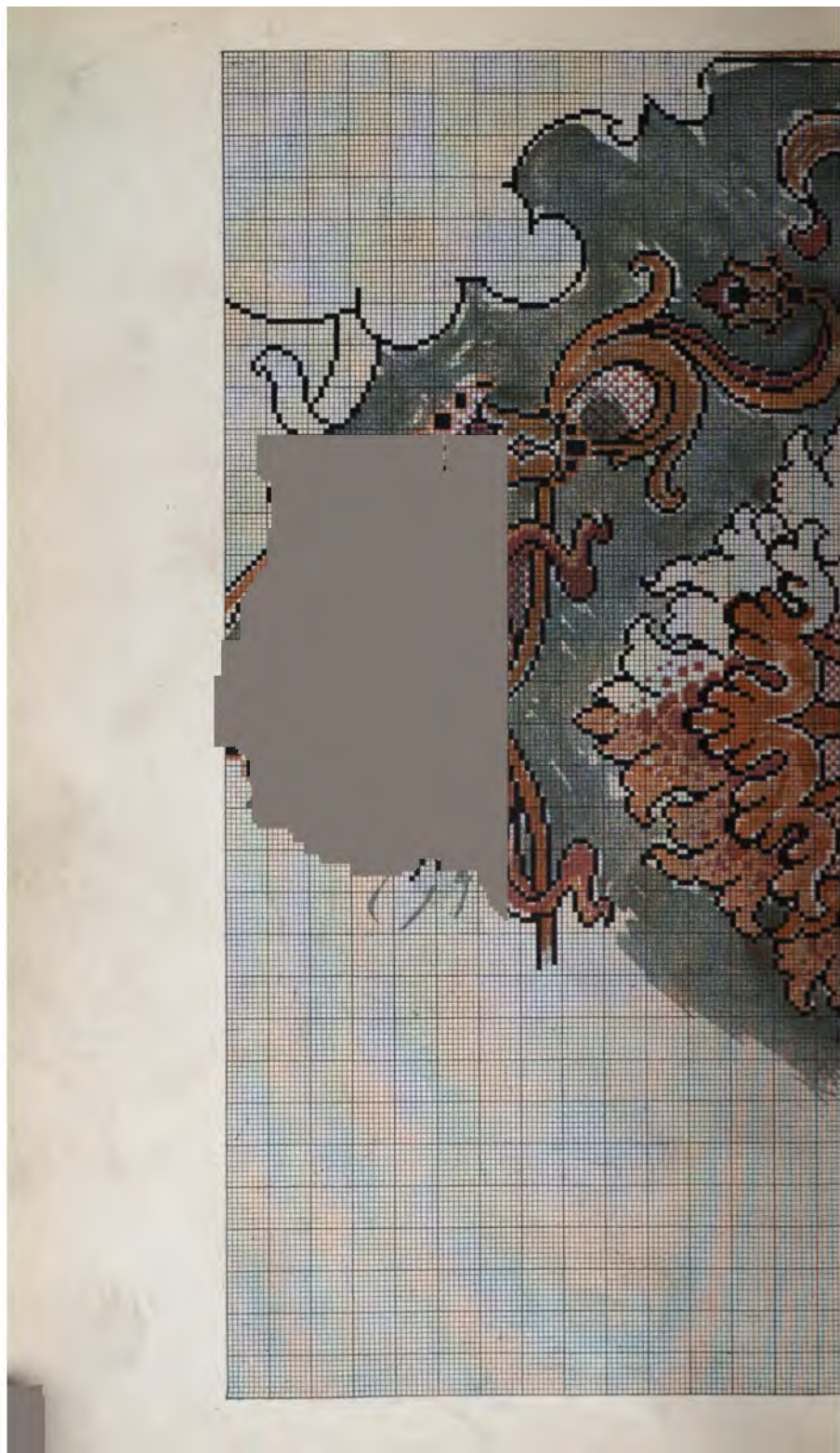

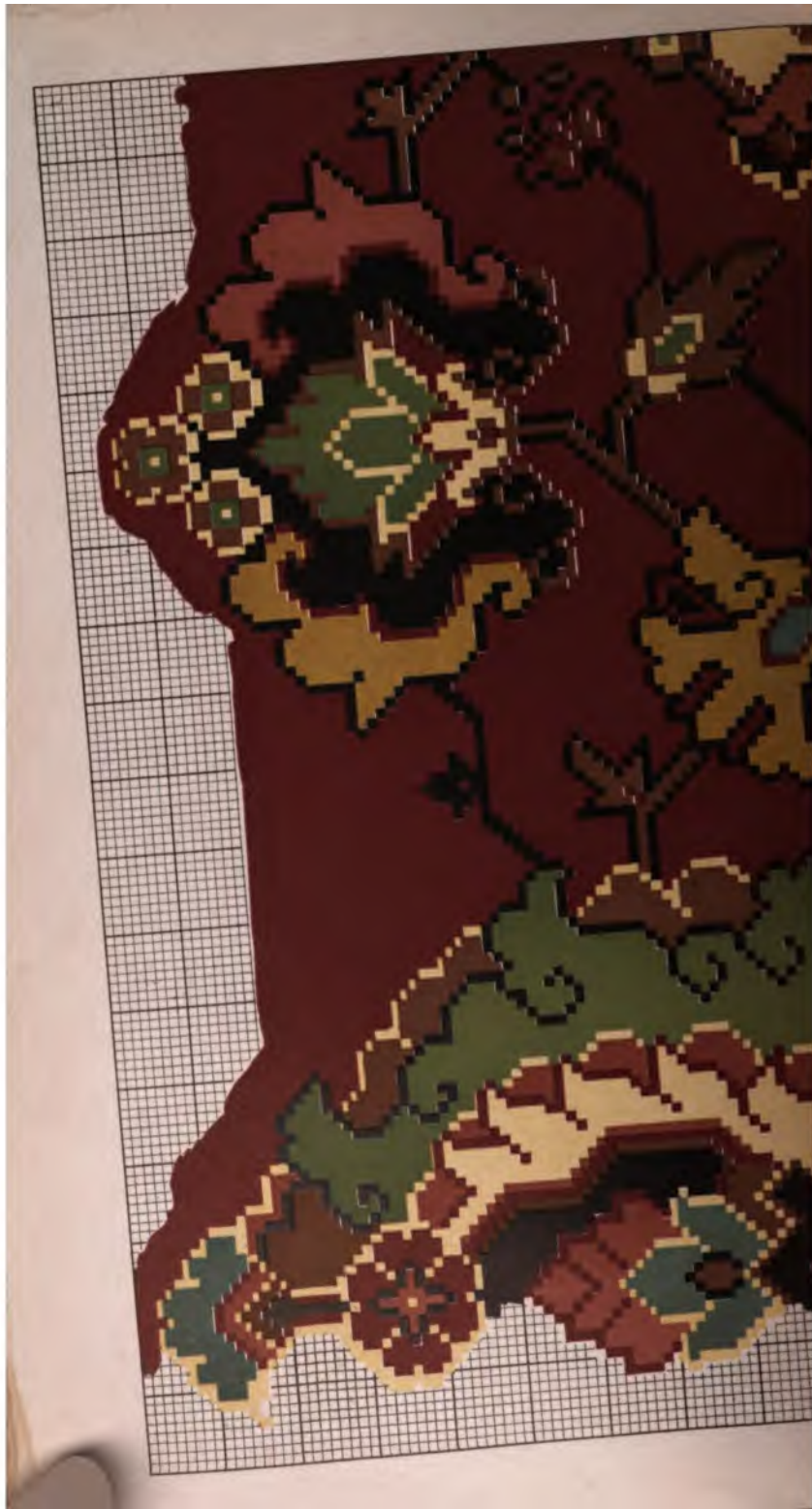

FIG. 4



1977

THE NEW YORK  
PUBLIC LIBRARY  
ASTOR LENOX  
TILDEN FOUNDATION



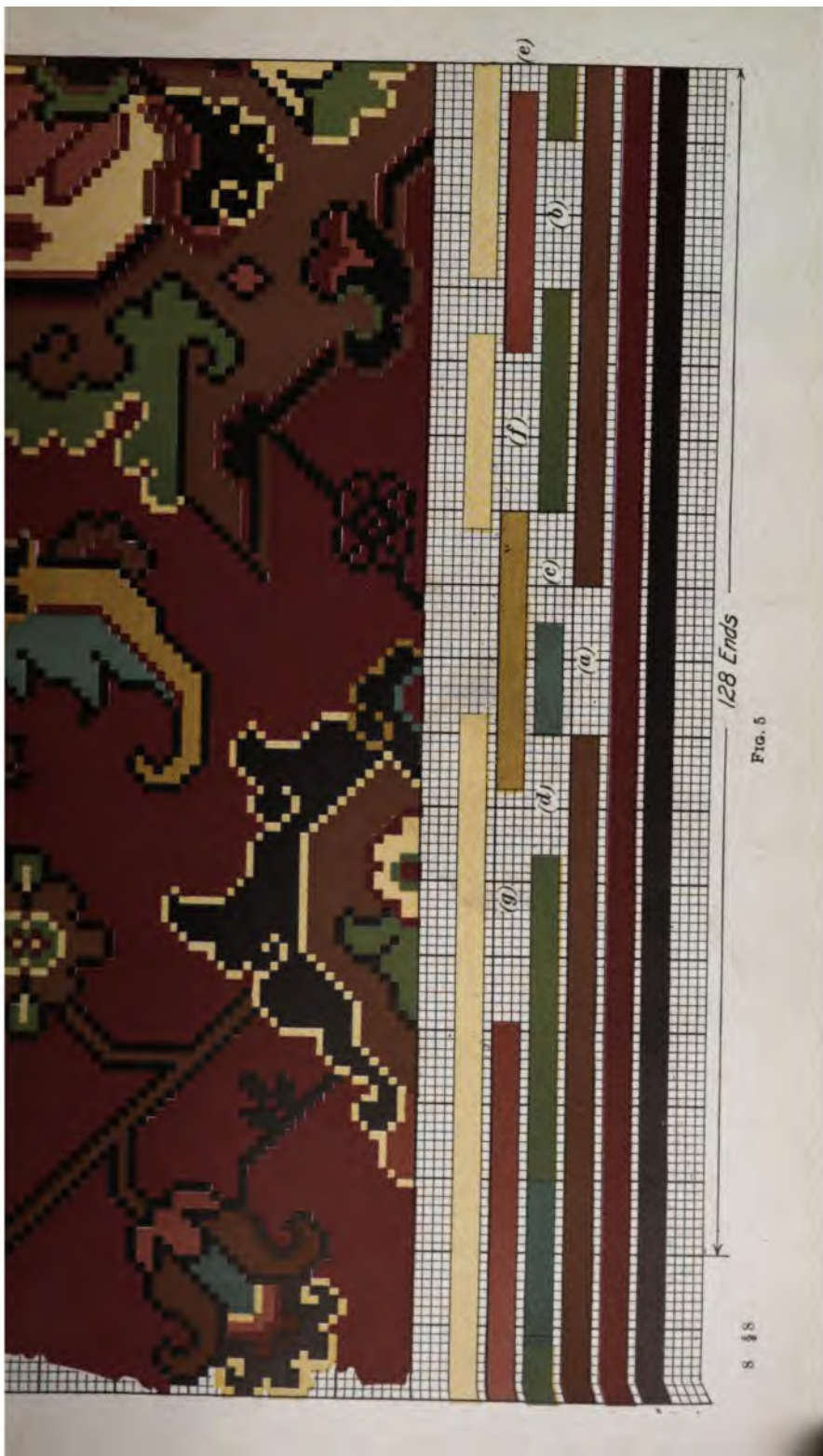
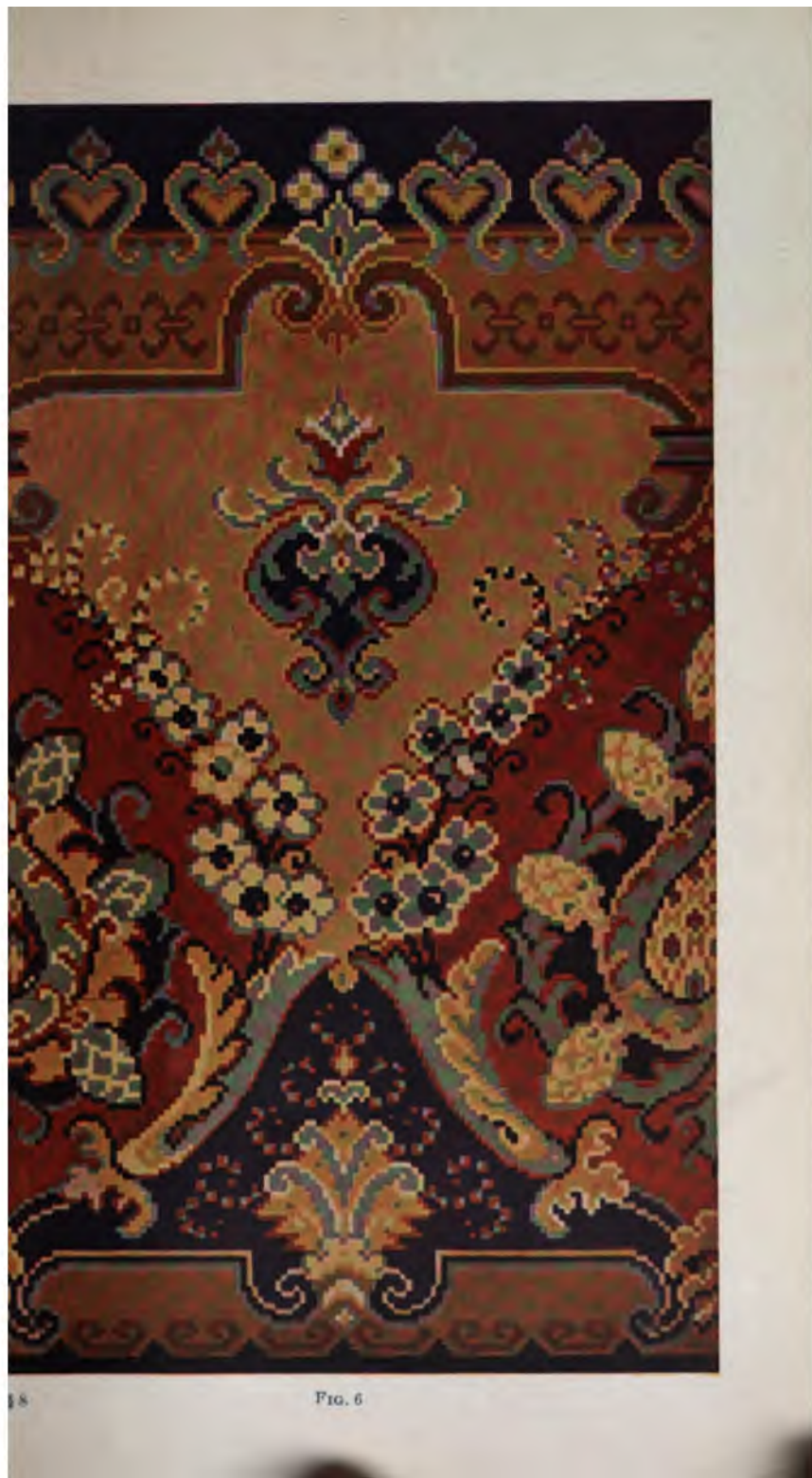

FIG. 5

100



THE NEW YORK  
PUBLIC LIBRARY  
ASTOR LENOX  
TILDEN FOUNDATION

THE NEW YORK  
PUBLIC LIBRARY  
ASTOR LENOX TILDEN FOUNDATIONS  
100 N. 5th St. New York, N.Y.







FIG. 7

THE NATIONAL  
PUBLIC HEALTH SERVICE  
AT THE HEADQUARTERS  
THE NATIONAL BUREAU OF HEALTH



FIG. 8





THREE  
FOUR  
FIVE  
SIX  
SEVEN  
EIGHT  
NINE  
TEN

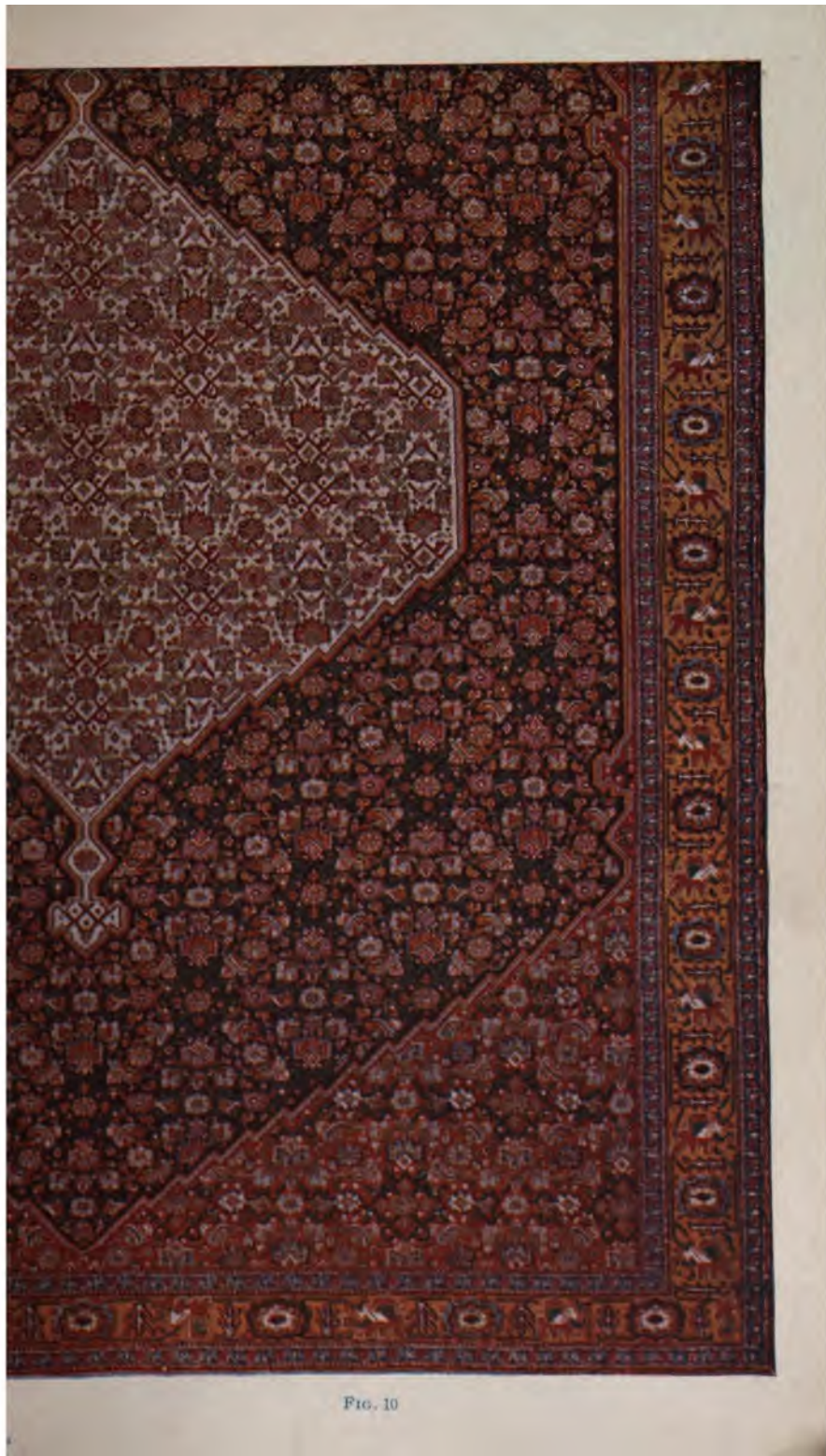

FIG. 10



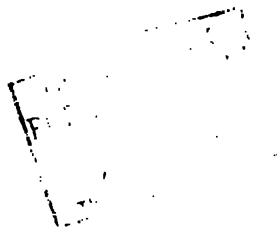
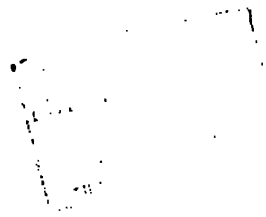



FIG. 11









7  
PUBLI  
ACQUIS  
TH 10 2









FIG. 15



variety. Floral patterns are still produced for cheaper grades of carpet, and even for some very expensive ones, an example of which is shown in Fig. 8.

In Fig. 8 is shown the modern Wilton border woven by one of the leading American manufacturers. It is a naturalistic arrangement of peonies and daisies, and strong in relief against the rich green ground. Although this is a remarkable example of what can be accomplished in weaving with five frames and a system of planting, it is a most extravagant realistic design, especially for a Wilton carpet, owing to the great waste of material. It would be interesting to work out the plant of this pattern, involving as it does twelve to fifteen colors, and it is a typical example of the amount of ingenuity and skill that the craftsman can waste in producing a pattern difficult to weave and expensive to reproduce without in any way being appropriate to its purpose.

Compare Fig. 9 with Fig. 8 and observe the contrast. Fig. 9 is a Morris design adapted to Wilton carpets. There are but four colors—two blues, two yellows, a red, and a green. The flowers in the pattern are honestly conventionalized to suit them to their purpose, the effect thereby being rendered perfectly flat and thoroughly suitable for a floor covering. It is not a pattern that would attract the public at first sight, but the public taste is growing in this direction, and the use of such patterns trains one to appreciate them and gives a feeling of satisfaction that can never be attained by such floral designs as were shown in Fig. 8. As public taste is improved the designer of conventional patterns will increase in popularity, and however great may be his skill as a weaver, the producer of patterns such as Fig. 8 will find his services less and less in demand as time goes on.

The better class of dealers, however, do not carry this line of goods, and the public is becoming rapidly educated in the theories of design and is able to appreciate the inappropriateness of floral designs of this character. The wide-awake carpet designer must keep himself posted concerning the demands of the public, and, like designers in other fields, he must anticipate the wants of the average buyer.

**17. Obtaining Suggestions for Designs.**—Students that know nothing about carpets, and carpet designers from a practical standpoint, should embrace every opportunity to go over the stock of a good retail dealer and learn, in connection with these, the character of designs that are most popular, and study at the same time the designs of wall-papers, furniture, and other elements of interior decoration that are presenting themselves in the market. Public taste first expresses itself in architecture and then in design, and from the character of furniture that we find exhibited in the windows we can determine the styles of carpets and wall-papers that will soon be in demand. The reason for this is very easily understood. The intelligent purchaser endeavors to furnish his house with various articles that are in accordance with the general style of architecture of his house, and as it is easier to express certain set forms and set styles in furniture one usually selects his floor coverings and wall coverings to match his furniture rather than to select his furniture to match the coverings.

With the delicately carved and simply modeled furniture that was characteristic of the earliest Renaissance, we find delicate arabesques adapted from carvings decorating the walls; and as the later Renaissance introduced the absurdity of Rococo ornament in furniture, accompanied by elaborate carving and much gilding, we find likewise reproduced in meaningless wall decoration and elaborate pilaster ornament, an excess of meaningless forms everywhere. With the period of the Empire that followed these absurdities, and the return of classic models and simple, severe furniture, with occasional ornaments and festoons carved and gilded, we have wall decorations of the same severe character corresponding with it in style. Likewise, at the present day with the introduction of the severe "Mission" furniture, and the later reproductions of furniture on the Gothic model, our wall decorations tend to tapestry effects based on Gothic ideas, and our floor coverings occasionally become simple and severe in design so as to be in harmony with their surroundings.

### ORIENTAL RUGS

18. The patterns characteristic of oriental rugs are seriously imitated with more or less success. In the Wilton carpetings produced by the modern loom, the carpet designer endeavors to secure, with the means at his disposal, the effect of bloom characteristic of the old oriental hand weaving. This can never be fully accomplished, owing to the limitations of the five frames and the planting. But inspirations can be drawn from the study of oriental patterns and worked up by the skilful designer into something that is suitable for modern weaving without being a direct imitation. Oriental rugs are hand made. Men, women, and even children are engaged before the loom tying, by hand, the tufts of dyed yarn that are to form the pattern of the finished fabric. These yarns, in the best quality of rugs, are dyed with a vegetable dye that is permanent and unchanging throughout centuries, except so far as it acquires a softening effect that delightfully blends one color into another. These rug weavers receive a mere pittance of a few cents per week for their services, and in oriental countries a carpet that may have taken over a year to weave does not represent any large amount of money to the weaver; and sells for what would be considered an absurd price in this country.

Commercialism of late years has entered the far East, however, and rugs are now made there with aniline dyed wools that fade and lose their freshness without acquiring the soft bloom so characteristic of the antique goods.

Every country in the old world had some particular guild of craftsmen that characterized the country, and the guild of most importance in oriental countries was that of the dyers. The dyers were divided into different classes according to the colors they could dye, and they lived in colonies regulated by the convenience of water facilities in applying

their craft. The dyes were applied by dipping the skeins of yarn in successive solutions alternately, and not by mixing the dyes to form a color as in modern times. The exact method of doing this was one of the guild secrets, as was also the length of time it should hang in the sun to dry and soften. There are no books of recipe for these dyes, but each dyer has a mental list of various shades that he can compound at a moment's notice in order to satisfy the demand. The skill of these dyers can be judged when we understand that one of them, blindfolded, can run his hands over a rug and describe the pattern accurately from the feeling of the different colors in the wool, so familiar is he with the effect of the dyes on the fabric.

The imitation of the ancient dyes by the modern products of coal tar has degenerated the rug industry materially, as has also the demand in Europe and America for oriental fabrics, and the Wilton rug woven on the loom is in many respects preferable to what are apparently genuine oriental fabrics, but which are in reality cheaper imitations of the ancient goods woven expressly to sell in European and American markets. In many new fabrics that come from out-of-the-way parts of the Orient, the dyes and wool are found to be thoroughly up to the old standard, but the majority of importations are sadly inferior to what we are led to believe is the characteristic quality of an oriental rug. The reputation of Persia rested on its rugs, and there was at one time a law that forbade the introduction into that country of chemical agents to be used as dyestuffs, and any dyer convicted of using aniline in his craft was sentenced to have his right hand cut off. Whether the law was enforced or not, consignments of aniline-dyed rugs continued to pour out of the country. On January 1, 1900, the Shah of Persia issued an edict, and had it printed in French as well as in Persian, in order that its circulation might be satisfactory, forbidding the use of aniline dyes in rugs and carpets; forbidding the introduction of aniline dyes into the kingdom either in dry or liquid form; forbidding the exportation of rugs dyed by any aniline process, and a number of other details all pertaining directly

to the maintenance of the high quality of Persian carpets. Notwithstanding all this, the market is still flooded with spurious imitations of antique rugs that have undoubtedly been woven by hand in Persia.

**19.** There is probably no article of household use of which the public is so generally ignorant as oriental rugs and their imitations. Rugs are classified under different names that usually indicate the city or community from which they come rather than any specific details regarding their manufacture. However, they are recognized usually by details of texture in the wool, the character of the knot employed to tie it, the material of the warp and weft, the length of the pile, etc.

A genuine oriental rug is usually a written page of history. The design is the development of a symbolism that has been handed from generation to generation, and that probably originated in Babylon or India many centuries ago. This inherited symbolism is the leading characteristic of all oriental designs, but the application of these designs to modern service requires their alteration to suit the mechanical limitations of the loom, and the designer can best serve his purpose by adapting the spirit that enters into these designs rather than the geometrical construction or outline itself.

**20. Reproduction of Persian Rugs.**—In Figs. 10, 11, and 12 are shown three reproductions made directly from the finest quality of Persian rugs. Fig. 10 is what is known as a Sehna, which is one of the finest qualities of hand-made carpets. The design in the body of this rug is what is known as the "Herati" pattern, or more commonly the "fish" pattern. It varies in size and method of treatment in different forms of rugs and is derived probably from ancient Chinese heraldic devices. The "fish" pattern is simple enough in itself and is admirable in its ground-covering qualities, as it works itself into an even bloom that conveys no definite idea of a fixed pattern but presents a satisfactory effect to the eye. The beauty of rugs of this character lies in the subdivisions of their color scheme, and in this manner



the three sections of the ground are brought out by changing the color scheme of this pattern, which is uniform throughout the entire body. In the center medallion the colors are particularly soft, and when looking at it with partly closed eyes the divisions of the pattern can be clearly studied, while the colors melt into soft grays that are almost a monotone tint and yet are vibrating with color.

In Fig. 11 is shown a Kermanshah rug. The designs of the Kermanshah rugs run to floral patterns. The texture is looser than the average Persian rug, and the influence of Turkish ornament is very apparent. The colors are rich and in good taste, and the effect of pattern is much more prominent than in the Sehna rugs. The warp of Kermanshah rugs is occasionally cotton, and the pile is tied with a Turkish knot, showing the influence of the latter country. The palmette and rosette forms that enter into the design are characteristic of oriental patterns and undoubtedly have been derived from similar patterns that existed in antiquity.

In Fig. 12 is a Feraghan rug, which shows an open or spread-out form of the "fish" pattern in the corners of the body. This, on comparison with Fig. 10, will show the effects that can be produced with this simple design by changing its color scheme and the elements of its application. The Feraghan rug in Fig. 12 is a modern rug. As in the ancient examples, the "fish" pattern was worked out over the entire center field, with the exception of small triangular corner pieces, as shown in this example. The characteristics of the ancient pattern have been carried out. The border is typical of the antique Feraghan rug, but the solid red center and the medallion are modern introductions due probably to an attempt to save labor and produce in less time and with less skill sufficient rugs to supply the market.

**21. American Wilton Rugs.**—In Figs. 13, 14, and 15 are shown three examples of ordinary Wilton rugs of American manufacture, 10 feet by 12 feet. They are all five-frame fabrics woven with conventional colors, namely red, blue, gold, ecru, and green. The borders in each case

are three-quarters of a yard wide, as can be seen by the seam, which falls exactly on the inner edge and thereby is entirely hidden.

These three examples undoubtedly owe their designs to inspirations derived from oriental patterns, but the coloring and general effect is far inferior to the softness of the Persian rugs, as may be seen by comparing any of them with Fig. 10. In general effect, they lack the treatment of the hand-woven rug and express emphatically the hardness of a machine-produced carpet. The limited range of color, necessitated by the loom, prevents that soft bloom that is so characteristic of the oriental fabric. Compare the body of Fig. 10 with its imitation in Fig. 13, and observe how the Herati pattern assumes a machine-like and geometrical grouping in the Wilton rug that does not exist in its oriental prototype.

In the finer grade of Wilton rugs, many colors are introduced by planting, and the effect is thereby much improved, but this is a characteristic that is affected by style in carpets and varies with seasons. At the same time, designs that present the softness of bloom characteristic of oriental fabrics are not popular owing, probably, to the fact that recent events in the world's history have filled the popular mind with a desire for brilliancy and loudness of color. In rug design, as in everything else, public taste is affected by entirely outside influences, and the relations of this country with some foreign power, be it oriental or occidental, are likely to bring some particular style into popularity and thereby affect all design.

22. In Figs. 14 and 15 will be found many forms similar to those in the oriental patterns, Figs. 11 and 12. The borders and medallions in the center appear to have been copied directly from some oriental example, although they may have been worked out from several sources of inspiration, but they lack entirely the spirit of the original fabric and fail to present that delicacy of tone that is the chief beauty of a Persian rug.

The designer of modern rugs and carpets must admit that with the means at his command the original effects cannot be successfully imitated, and while a conscientious study of oriental patterns is of the greatest value to the designer, he should not be led to the extreme of endeavoring to reproduce them, as the most successful efforts in this line must necessarily fall below the originals. But a proper adaptation of this system of space filling is far superior to the gaudy naturalistic floor coverings that are so frequently seen in the modern carpet store.

# OILCLOTH AND LINOLEUM DESIGNING

## PRINTING OILCLOTHS

### INTRODUCTION

**1. Preparing the Blocks.**—In Fig. 1 are shown four blocks of an eight-color pattern. All the forms that are to be represented in one color in the finished design are traced on one block. The superfluous wood is then cut away, leaving the desired form in relief. This operation is

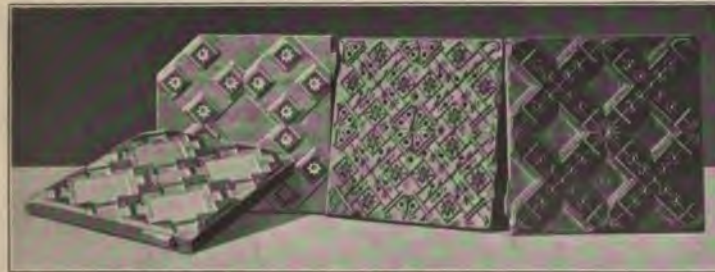

FIG. 1

then repeated on another block for another color, and so on throughout the pattern until each detail of the design is provided for.

Where the colors come together, the edges are apt to be blurred and ragged; therefore, **outline blocks** are prepared, usually in metal. These are printed last and even up the rough edges, as they contain only the outlines of the figures. They give a finish to all the forms and make them stand out

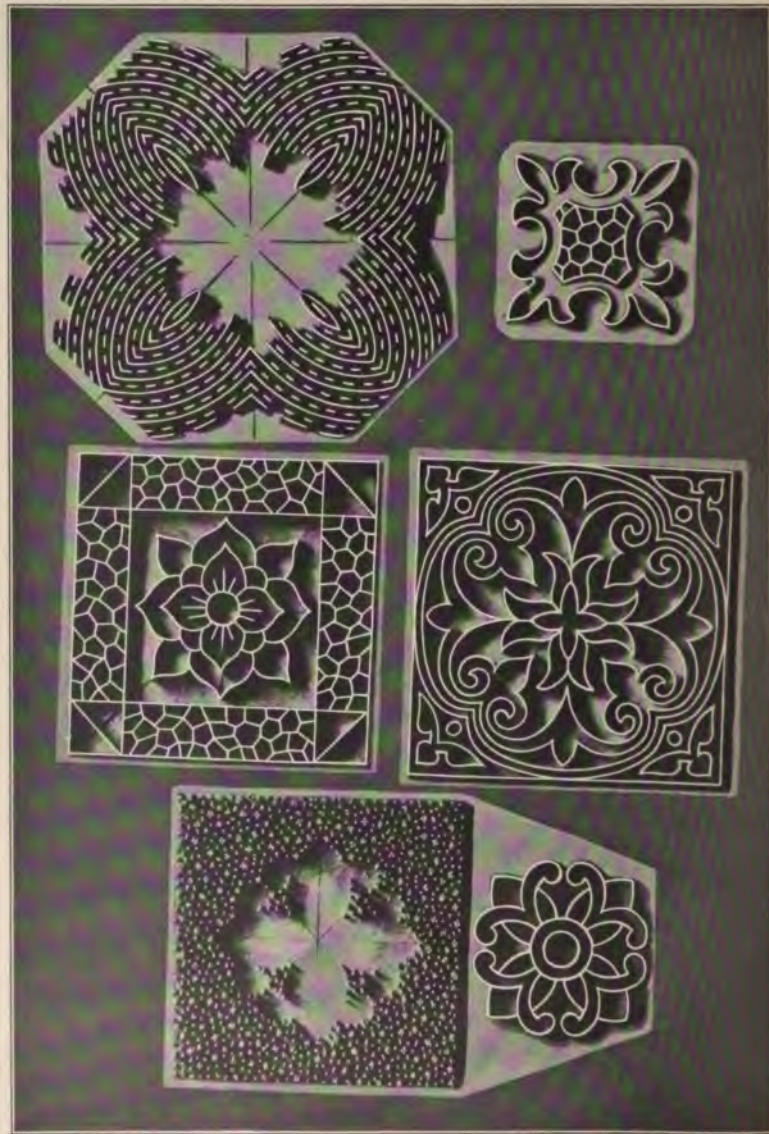

FIG. 2

sharply and clearly. It does not necessarily follow that these outline blocks are a different color from the colors printed on the design. Sometimes they make a black outline around certain details, and at other times they are the same color as one of the two adjacent forms that they even up. It is necessary, however, for the designer to bear in mind that an outline block must be cut for every design of oilcloth, whether it is executed in two colors or ten. A two-color design requires three blocks, the third block being an outline block. Fig. 2 shows several examples of outline blocks.

The matrix, or mold, for these metal blocks is made by burning the lines, or forms, into a wooden block to a depth of about  $\frac{3}{16}$  inch, by means of tools heated by electricity. Probably, in time, metal blocks will entirely supersede wooden ones. The matrix having been made, any number of castings can be taken from it, affording duplicate blocks for the different printing machines, and permitting the same pattern to be printed on different machines at the same time, while old or worn-out blocks can easily be replaced.

#### THE PRINTING PROCESS

**2. Hand Printing.**—When oilcloth is printed by hand, the design is usually manipulated by two men. The prepared jute burlap, which forms the backing, is rolled about a rod at one end of a long, low table beside which the two men stand. Immediately behind them is a rack to hold the different blocks required to print the pattern and slabs or pads containing the different colors. The color, which consists of oil paint, is spread evenly over the pad and the blocks are lifted from the rack and pressed on the color pad, and then transferred to the surface of the cloth and pressed firmly into place. In this manner, each successive color is applied to the design until all but the outline blocks have been used.

At this stage of the work, a plain **mash block**, as it is called, is laid over the surface of the oilcloth and heavy pressure exerted, which forces the design and color firmly

against the fabric. The use of the mash block also tends to spread the color somewhat and destroy the evenness of the edges, but the application of the outline block trues up these edges and makes the forms clear-cut. On the sides of each block are fastened small wooden projections and a screw head to act as a guide in printing the pattern, so that each form will fall in its proper place.

When one set of impressions is complete, the fabric is moved forwards, on the table, a proper distance and the next section is printed; and so the operation is repeated over each section of cloth, until the end of the roll is reached. The printed cloth as it proceeds from the end of the table is carried over long, low drying racks, where it remains for several days until the surface is perfectly hard and dry.

**3. Machine Printing.**—Oilcloth printed by machinery is similar in process of manufacture to that made by hand, and there is so little difference in the quality of the finished fabric that it is likely that machine work will supersede hand work entirely in the near future.

In the oilcloth-printing machine, the material is, as before, passed over a long, low table with a metal top. Above this, the different printing blocks are set at regular intervals, each with a roller carrying color immediately beneath it. The rollers revolve constantly in a trough containing the paint, and as the blocks are raised from the cloth after impressing their design, these color rollers pass under them and distribute the color across their surfaces. While this is being done the fabric moves forwards the proper distance on the table, so that in each case the impression made by one block falls into position to receive the proper impression from the next block beyond. Thus, the blank fabric fed into one end of the machine from a large roll emerges from the other end entirely printed, the outline block being the last of the entire series, as in hand printing.

The blocks for machine printing are much larger than the blocks for hand printing as they extend the full width of the material, and in this way very large orders may be turned

out in a very short length of time. Hand work, however, is still used where samples are being made up or new goods are being prepared for the market.

4. **Inlay Work.**—The only difference between ordinary linoleum and oilcloth lies in the preparation of the fabric on which the design is printed. However, the linoleum, known as **mosaic**, or **inlay**, wherein the design extends all the way

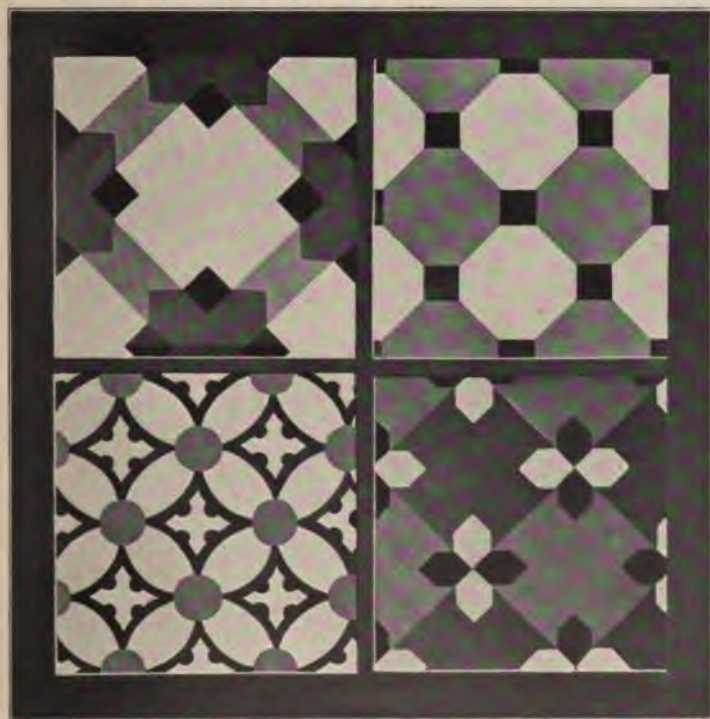

FIG. 3

through the goods, differs from oilcloth in the method used in its printing. The fabric will therefore wear and preserve continuity of design until the prepared surface is worn clear through.

Mosaic linoleum is prepared by first cutting pieces of colored linoleum pulp, by means of dies, and arranging them



side by side on the raw jute burlap, thus forming a sort of tile pattern in different colors. The burlap and pulp are passed under a heavy heated plate, which is brought down on them with a tremendous pressure, literally welding the parts into one homogeneous mass and uniting them perfectly with the burlap backing.

A process producing similar results is one wherein the dry pulp in granular form is sprinkled on the burlap backing through a series of stenciled plates or patterns, after which it is submitted to heavy pressure and heated as before, and thus becomes a solid fabric.

Inlay linoleum is much more expensive than painted goods, on account of the intricacies of its manufacture, but it has many advantages, as the pattern will not disappear until the burlap is worn through, and this will require a much longer time than the simple burlap prepared with paint. The inlay linoleum is not so attractive, however, to the designer, for the limitations of the present method of manufacture impose such decided restrictions that one can work out nothing but very simple patterns. Fig. 3 illustrates four patterns of inlay linoleum that show precisely to what extent designs can be varied in this method of manufacture.

---

## THE DESIGNS

**5. Styles of Patterns.**—There is practically no limit to the kind of pattern that the manufacturer of oilcloth and linoleum can successfully reproduce in printing. Sample books from the different factories show a great variety of styles, from the simplest diaper pattern in two or three colors to elaborate floral scrolls in imitation of wallpaper and carpet designs, printed in six or eight colors, as clumsy and ungraceful as they are inappropriate.

In Fig. 4 four of these elaborate patterns are shown, but it should be borne in mind that their appearance is greatly improved by photographic reproduction, as the varying contrasts of color and shiny surface of the paint are thereby lost. There is no doubt that the simple diaper



(a)



(b)



(c)



(d)

FIG. 4

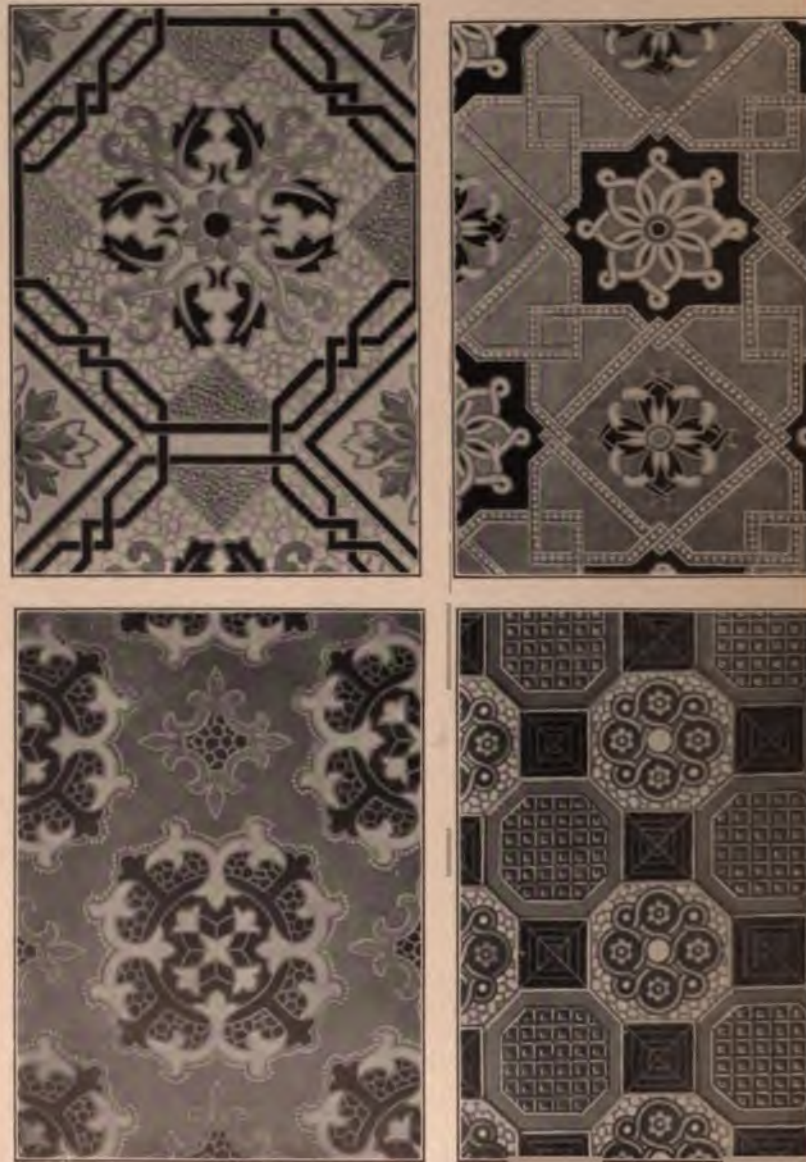

FIG. 5

patterns shown in Fig. 5 are far more suitable for this class of work than the elaborations shown in Fig. 4.

The simple mosaic work represented in Fig. 6 at (b), (c), and (d) is a very popular style of design; this illustration shows what a great variety in so simple a pattern can be obtained by the judicious use of proper colors. Of these designs (a) and (c) were executed by Philadelphia manufacturers, but (b) is the work of a British firm.

Almost every manufacturer runs a pattern similar to these, for the reason that it is one of the best "sellers" ever produced, and for a similar reason the simple tile pattern illustrated in Fig. 6 (c) can be found among the products of nearly all manufacturers. It is a well-known fact in the trade that whenever a given pattern attains an unusual sale, all the enterprising manufacturers will copy it, making but slight modifications, in order to each get his share of the trade.

The oilcloth designer never knows when his pattern is going to make a hit. He



(a)

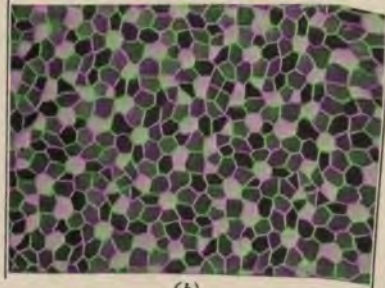

(b)



(c)



(d)

FIG. 6

may be well pleased with his design and feel that it is bound to meet the public approval, but his opinion must not only be assured by the public themselves but also by the majority of the buyers in the manufacturing establishment where he proposes to sell his design, as every person connected with the manufacture of the goods, from the superintendent to the order clerk, will have a personal opinion as to the value of the design and prophesy its success or failure according to his own ideas.

**6. Catering to the Public.**—Widely different patterns frequently attain remarkable successes and sell in larger quantities than other designs that are on the market at the same time, thus necessitating the manufacture of millions of yards of one pattern throughout a period of several years. It is naturally the desire of manufacturers to become possessors of patterns that please the public in this manner, as it simplifies matters for them materially. It is the aim of every designer to prepare patterns that will be good sellers, and to avoid submission of patterns that are not likely to sell well. The successful oilcloth designers whose goods are most sought after, are those whose patterns most frequently attract the public and cause a sufficient run of one kind of goods to make it worth while to buy the designs and prepare them for printing.

Designers, manufacturers, and salesmen all admit that they have never been able to analyze the public taste sufficiently to determine just what the qualities are that cause a pattern to be popular. Fortunately, however, for the designer, one thing is certain, and that is that the public is very fastidious and demands a large number of designs from which to select, and consequently the manufacturer is making up new designs and getting out additional sample books every season. The poor sellers are withdrawn from the market and the good sellers are pushed, and the spaces in the sample books left by the removed examples are filled with new designs that the manufacturer hopes will bring better returns. Occasionally, the same pattern is printed in

many different colors, in order that the public may not be confined to one scheme of coloring.

#### **7. Principles Governing Floor-Covering Designs.**

The artistic principles governing designs for floor coverings apply to oilcloth and linoleum quite as much as to carpet, mosaic work, and parquetry. Oilcloth designing affords a most excellent opportunity for the application of these principles, as the limitations of its manufacture and the space usually allotted for the repeat, being simply 9 inches, tend to prevent the designer from producing coarse and sprawling patterns. This should be particularly considered, as the tendency among some carpet designers is far too strong in this direction.

The rules governing a design for floor covering are few. First of all, the design should be such that the floor appears flat. Any tendency to show an undulating or coarsely interwoven element is not only out of place, but annoying. Any attempt to show a modeled or rounded surface or lumpiness, or arrangement of colors that produces the effect that some parts are lower than others, is bad in design and will surely condemn the goods. In a floor covering, the feeling of stability is paramount, as one does not wish to feel that there are even imaginary obstacles in the way or unknown depths into which one might fall through jagged holes.

This principle is constantly violated by designers of carpets; therefore, we frequently see patterns of floor coverings representing large bunches of elaborately modeled flowers and leaves, or occasionally animals and landscapes, so realistically treated that one would almost suppose the designer was trying to impress the user and observer that they were intended to be hung on the wall as decorative elements rather than spread on the floor as utilitarian details. The effect that a pattern impresses on one in a dimly lighted room when he views it with partly closed eyes is almost identical with the constant impression that is unconsciously produced on us at all times when the object is in our full field of vision, even though we do not really

look at the object at the time. If one walk across a dimly lighted room where one of these distracting patterns covers the floor and if in so doing he partly closes his eyes, a feeling of uneasiness and uncertainty immediately takes possession of him. The effect is not restful, and the pattern is therefore not a good one to have around. If this test be tried on such ideal floor coverings as the best oriental rugs or good mosaic and tile effects, there is not the slightest uneasiness; and, even though the pattern possess decided contrasts in light and shade or color, there will be a feeling of restfulness as one melts into the other and produces a delightful unity of effect. Floor coverings that stand such a test as this also fill another and important office, namely, that of being a proper background for objects in the room, such as furniture, etc.

8. A most important part in the general effect is produced by **color**, although in the manufacture of oilcloths this detail is practically taken out of the designer's hands as the manufacturer is likely to accept a design executed in one set of colors and print it entirely different. There should, however, be a definite intention on the part of the designer in the color scheme of his design, and he must determine whether he wants to produce the general effect of a neutralized bloom or blending of all the colors, or to contrast some strongly with others; and the fact that the designer cannot control perfectly the colors that his design is to be printed in should make him all the more careful of making the design interesting in point of form and arrangement.

It is worthy of note that designs such as those illustrated in Fig. 6 do not violate any of the rules set forth for floor coverings, although they are great sellers. It cannot be argued from this that the public is any more familiar with the rules for floor coverings than it is with other details of fine art, but there is no doubt that a sufficient number of the public have that feeling of uneasiness in the presence of a bad pattern to cause the rush in favor of the better goods.

There is nothing in these designs to positively recommend them in beauty of color or design, and their good qualities are of a negative character; that is, they possess no forms of sufficient importance to make one stop and think whether or not he likes them. A shrewd housekeeper buys them because they are not loud or offensive, they do not show dust, and they are easily patched. There is another class of buyers, smaller in number than the former, that want a design that is positively interesting in form and color; some of these rush to the elaborate floral effects illustrated in Fig. 4, while others satisfy their desires and taste by a design that fulfils all the requirements of a good floor covering. It is the public that buys, and the manufacturer must prepare goods to suit all classes.

**9. Classes of Designs.**—The designer must be able to produce three classes of designs: (1) designs that are good floor covering, pleasing in form, and harmonious in the theory of design, to suit the public that is educated and knows what a design should be; (2) where elaborate floral devices in bunches or strewn in garlands form the principal theme in loud and contrasting colors, that a certain number of uneducated people can best get their money's worth in noise and brilliancy; and (3) a class of design for the great middle class that knows these florid and ostentatious designs are in bad taste, but that does not feel itself equal to the appreciation of the first lot and therefore must be content with simple, inoffensive patterns like Fig. 5, whose main virtue lies in the fact that even though one cannot say they are good, he cannot say they are very bad.

The majority of oilcloth patterns are made by public designers or designers for the trade, a large number of whom are women. Some manufacturers employ special designers, but even in such cases they buy of outside designers when the designs suit their purpose. The price of an oilcloth design is standard—\$10. If the manufacturer wants a design at all, he pays \$10 for it, no matter whether the



designer be a beginner or one well known. If he does not want it, he has his reasons and will not take it at any price.

**10. Preparing the Design.**—Designs should be made on a good quality of white drawing paper, and should exactly repeat within a 9-inch square. There may be more than one repeat in this square, but no matter how many there are the above conditions must be fulfilled, or the design cannot be reproduced. The drawing paper must be carefully stretched, and when the design is entirely completed, the paper should be cut from the board, leaving a 1-inch margin or blank on the lower and right-hand sides, but should be trimmed close to the pattern on the other two sides. This is done in order that the prospective purchaser may view the pattern in his double mirror, which shows a complete set of four repeats surrounded by a white border.

Every designer should have a similar mirror for testing his patterns. It consists of two pieces of looking glass arranged at right angles, so that when the design is placed in the angle it may be seen repeated in each direction. The mirror is also useful for the construction of certain geometrical units used in reproduction, as a number of remarkable forms can be obtained by arranging a few abstract forms in the angle between the two glasses.

**11.** The colors used in designs may be checked off on the margin at the upper right-hand side, but the little blocks containing these color checks should be free from the edges of the design. A  $\frac{1}{4}$ -inch to  $\frac{1}{2}$ -inch block for each color is sufficient, and black and white count as colors and must appear in the scale.

Usually, one color is employed for the outline, but any color or black or white may be used. If two colors are used in the outline, let it be for some good reason and explain the reason, or the block cutter will probably reduce the design to one color in order to save the cost of the extra block. The outline is necessary to clean up the printing, and it frequently helps the appearance of the design on paper. Therefore, in finishing up a design, care should be taken as to the

color and placing of the outlines, in order to get the best effect possible.

In Fig. 7 is shown a design, drawn by a student, that is not properly outlined. The large circles are outlined but the cross form is not, and in Fig. 8 the simple rosette in the center is outlined, but the interlacing circles are not.



FIG. 7

Where it is desirable to avoid the effect of an outline, it can be applied in the same color as the form around which it is placed, thereby fulfilling the printer's requirements of a clean edge but not appearing in the finished goods. In Fig. 9, however, it will be observed that all the outlining is properly considered and that each color in

juxtaposition with another color is separated therefrom by a black outline.

The outline should be firm and well considered. It must neither be thin and wiry nor thick and clumsy so as to be misconstrued into a detail of design. Oilcloth design does not admit of minute details. Every element introduced must be large enough to admit of a strong outline, or it cannot

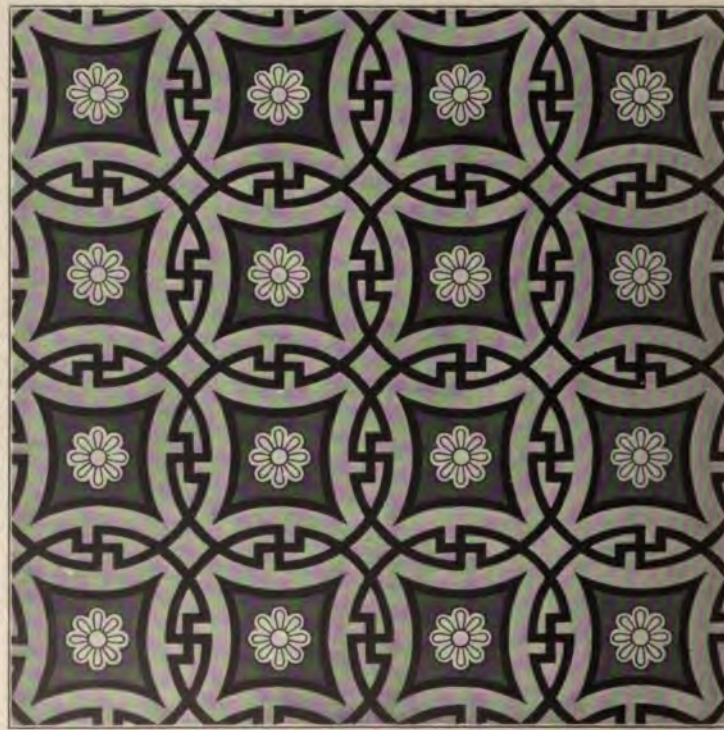

FIG. 8

be properly printed. However, where designs are made for inlay linoleum, outlines are useless and out of place.

**12. Colors.**—In all printed fabrics, whether wallpapers, oilcloths, or linoleums, the manufacturer desires to get a maximum effect with a minimum cost of production, and as each additional block means additional cost it is certainly

Important that as few colors as possible be made to serve the given purpose. All other things being equal, the designer that can handle his designs in four colors and produce the appearance of six by skilful repetition or juxtaposition in dots and lines stands the best chance of disposing of his work. On the other hand, if a manufacturer takes strongly to a design he is likely to spare no pains or

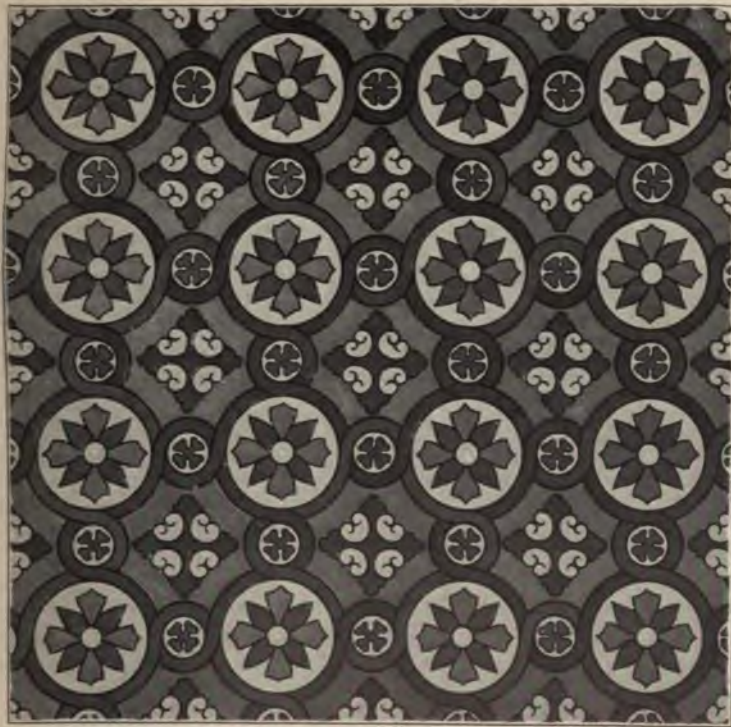

FIG. 9

expense to reproduce it satisfactorily, even making two blocks at times for the printing of one color if, by so doing, a better effect can be obtained.

In color effects for linoleum design, the golden brown of the linoleum pulp is made use of very frequently as the fundamental tone of the design. This color can be imitated

on the palette by a mixture of burnt umber and raw sienna. Considerable variety of effect in color and in texture may be obtained by working over this ground color by hatchings or by representing on it geometrical forms or spots.

In Fig. 10 is shown a popular pattern that is composed entirely of lines and spots printed in five colors on a ground of linoleum color, which is, in reality, the color of the prepared and painted burlap. This background of linoleum color forms the principal color scheme in the circular spots and also shows around the smaller spots, which only partly



FIG. 10

cover the spaces formed by the intersections of the crossing lines.

Notwithstanding the fact that this pattern has been a good seller and therefore a profitable one to the manufacturer, it is best as a general rule to avoid preparing designs that introduce large circular forms. Such patterns seldom take with the public, and the fact that this pattern did so is an exception to the general rule, and goes to show the uncertainty of popularity in designs. Even though the designer might succeed in creating another design based on circles that would be destined to meet with public favor, he will experience difficulty in getting the manufacturer to accept

it on account of his prejudice against circular forms. Therefore, in suggesting to the designer that he avoid circular forms in his designs, a purely business consideration is set before him and not one based on any theory of art or design.

Designs like those shown in Fig. 7 appeal strongly to the student, as, by an interlacing of circular forms, he is able to produce interesting geometrical combinations that work themselves out with little mental effort. This style of design is rapidly drawn, and the application of other circular forms to fill the larger and intervening spaces is readily suggested by the character of the space to be covered. However, the design shown in Fig. 8, though still based on the circle, is better in market value, as the circle is broken by its geometrical combinations with straight lines. While the pattern itself is not greatly unlike that shown in Fig. 6, the ingenious interlacing of circles adds to the interest and helps to overcome the prejudice that is naturally felt against circular forms. In Fig. 9, the circular forms are not objectionable at all. There being two sizes of them prevents the predominance of the larger circle, and the happy relations of the colors relative to the background and geometrical figures reduces the entire design to one of color effect, rather than geometrical combination.

13. Figs. 7, 8, and 9 were made by students working on practically the same problem; that is, an oilcloth design based on circles in combination with geometrical forms. These three designs illustrate how three different designers can draw three separate ideas from the same material, and it is not unreasonable to say that the relative value of these designs is exactly proportional to the amount of study and brain work the designer has put into his drawing.

In Fig. 7, the designer has attacked the problem by swinging together a number of circles to cover his space and filling in the space that they failed to cover with a simple geometrical form. He did not consider that the average manufacturer is opposed to designs based on coarse

circles, and therefore the circular element in his design is the most prominent.

In Fig. 8, the designer has evidently considered the fact that the manufacturer is opposed to circular forms and has endeavored to disguise his circular forms by breaking them with simple interlacings where they intersect. He has failed, however, to disguise them satisfactorily, because the circular forms on this design are red and the background against which they appear is green. By this strong contrast the conspicuousness of the form is increased, and although the design is better and shows more care and thought than Fig. 7, it is still too evident that the circle is the fundamental principle of its construction.

In Fig. 9, the considerations are entirely different; the designer has evidently carefully thought over his problem. According to the problem, he must use circles and he may use other geometrical forms. He knows that the manufacturer is opposed to circular forms and attempts to disguise them. Large circles tangent to the small circles are used, with intervening spaces filled with rectangular forms, the outlines of the rectangular forms being composed of arcs of broken circles. Everywhere throughout the design is the evidence of variety and contrast of curve, so that the attention is distracted from the circular forms in the general effect of the whole. Having accomplished this, the designer has evidently given considerable thought to his color combinations and has been careful that while the adjacent colors harmonize satisfactorily they do not contrast so strongly as to give undue evidence to the predominance of the circle; and where the circular form is conspicuous, it is not too large nor too prominent to appear to dominate the design.

It is interesting also to note in connection with these three designs the fact that was pointed out in Art. 11, namely, that Figs. 7 and 8 are not properly outlined, while Fig. 9 is. The designer that best understood the conditions of the problem was the one that was most careful to execute his design not only in accordance with the limitations of the problem, but in full accordance with the

limitations of the printing machinery and the demands of the manufacturer.

14. **Sources of Ideas for Designs.**—In historic ornament, much profit can be derived from a careful study of diaper patterns, particularly those characteristic of the Oriental and Gothic styles, as these styles are based on geometrical principles, and therefore well suited, with slight



FIG. 11

modifications, to print in the geometrical manner required for oilcloth and linoleum. It should be borne in mind, however, that in borrowing forms and ideas from historic ornament one must be careful in his selection, as symbols and elements may be taken that are highly unsuited to the design of floor coverings. We find much in



the history of ornament associated with religious ideas, and throughout all time the greatest perfection in ornament has been in some way associated with some intellectual conception of a religious idea. For instance, it is a well-known fact that the cross emblematic of Christianity enters largely into historic wall decorations in the Gothic style. This should be most carefully used in oilcloth design, and must surely be of such a form as not to suggest the slightest symbolism, for one large class of buyers would reject it as a symbol of Christianity, while another large class would reject it as too sacred to walk on.

It is always possible to create new designs based on well-known arrangements of geometrical lines, and the combination of geometrical forms and severely conventionalized floral forms may produce an endless variety of design combined with a large degree of originality.

Fig. 11 is a design, by a student, based on simple tangent circles cleverly broken by severely conventionalized leaf forms. It requires but little study to observe that this design is strongly Gothic in feeling, and but a variation of many Gothic diapers exhibited in the mural paintings of the Decorated Period.

Close adherence to geometrical diaper patterns will prevent the student from getting far astray in oilcloth design. Sprawling scrolls and attempts at naturalism, as shown in Fig. 4 (*a*) and (*b*), should always be avoided, for even though one of these designs is occasionally put out by a manufacturer, they are all bad for a student to strive for as they are inappropriate and inartistic; and despite the vulgarity of public taste, the proper and artistic forms are the ones that survive. Naturalistic renderings of floral and vegetable forms suggest a delicacy of handling entirely out of harmony with printing in heavy oil paints. The principal aim of the purchaser is to secure a design that is interesting and will wear well; the finer the lines the more the design will be affected by wear, and the longer the design wears the more popular will be its sale; therefore, the more successful will be the designer.

Adaptations of the forms so popular in L'Art Nouveau have found their way into oilcloth design, but have not attained any great popularity in this field. It is probable that this is due to the fact that the character of this style is not yet thoroughly understood by the public, and that the oilcloth designer has not yet been able to reconcile it properly with the limitations of oilcloth manufacture. It is to be hoped, however, that this will soon be attained, and the designer that is first able to popularize this style is sure to find a ready market for his designs.

**15. Originality an Essential.**—All designers should avoid the error of presenting to the manufacturer a design that is partly copied or suggested from the design of some other manufacturer, or from sample books. The experienced manufacturer will detect the fraud at once. He is experienced in buying designs and has devoted considerable time to the study of designs shown in the sample books of his rivals. He has watched the market to know what designs are good sellers and what are poor ones, and if he decides to deliberately copy a popular design of some other manufacturer, he will do it, with a perfectly clear conscience, by buying a sample of the goods themselves and handing it to his block cutter to vary sufficiently to make the design his own property. The manufacturer, therefore, will not buy designs that suggest in the slightest degree some other popular pattern. It is necessary to point this fact out very strongly, because young designers very frequently present for sale to manufacturers, designs that have already been on the market, or are but a slight variation from an existing pattern.

**16. Salable Designs.**—A design, in order to be salable, must be thoroughly practical and must contain some good points of its own aside from its practicality, or the manufacturer will not go to the expense of having the blocks cut. An infinite amount of variation can be played on certain geometrical forms that have been made use of throughout all history for surface decoration; but it should be borne in

mind that many of these have been used so often, with slight variations, that they have become thoroughly exhausted, and the designer should not be despondent if some of his first patterns submitted to the manufacturer were rejected on the ground that the same pattern had been manufactured before.

A design that may be entirely original with the designer may be based on certain geometrical lines that make its general form so familiar to the manufacturer that he is convinced that he has seen practically the same thing before, and in such a case the effect on him, whether right or wrong, is precisely the same as though he actually had seen it before.

The successful oilcloth designer must be wide awake. He must be able to turn over every ornamental form in his mind and decide if that can be applied successfully to oilcloth, and if so, how. He must understand well the principles of his craft, keep constantly in touch with the best things that are being done, follow carefully the public taste and keep in advance of it. He also must not be led into the following of the style or manner of other designers because they are successful, for the details of all their designs that cause them to be successful are the only details of those designs that cannot be copied; that is, the individuality of the man that made them. It is the individuality of the designer that characterizes his work, in the same manner as it is the individuality of the individual that characterizes his handwriting. The same idea can be conveyed by several people in several styles of writing or methods of expression, but one of these persons will express it better, write it better, or state it more clearly than the others, and it is the individuality of this person that impresses itself in his writings.

In the same manner, several designers may take the same idea and work it into a design and get several different results, one of which will be better than the others. It is the individuality of this one designer that has brought his design into prominence compared with the others, and one cannot copy that design, and vary it somewhat in order to

**§ 9 OILCLOTH AND LINOLEUM DESIGNING 25**

disguise the theft, without destroying the originality of the original designer and substituting the personality of the copyist, thereby probably destroying the popular value of the design itself. A person that is weak enough to copy the design of another, rather than invent work of his own, will impress his weakness on his copy of the design to such an extent as to neutralize entirely the strength of the original. Therefore, it should ever be borne in mind, to create all designs from original motives and to carry them out without thought of other existing patterns.



# WALLPAPER DESIGNING

---

## MANUFACTURE OF WALLPAPER

1. In **wallpaper design**, it is necessary that the student should possess some familiarity with methods of manufacture, and should have a fair practical knowledge of the limitations that are imposed by the nature of the machinery and the methods of its operation. The designs that are most salable to the manufacturer are those that are executed with six or eight colors and present the effect of ten or twelve colors. In estimating the number of colors on a paper a light background is never included, as this is put on the paper by a special grounding machine before the regular printing is done. Gold should be used sparingly, as it not only materially increases the cost of the paper, but also adds to the difficulties of its manufacture.

2. **Hand Printing.**—In the printing of wallpaper, each color or tint is applied by means of a separate block or roller—blocks being used for hand printing and rollers for machine printing. In **hand printing**, a rectangular block is cut so that its surface presents, in relief, the elements of all parts of the design that are in one color or tint. The paper, which is in a continuous roll, is at the end of a long table, by which the printer stands, the paper being at his right. Behind him and also to his right are placed the tray of color and the color pad on which he places his block, holding it by means of one or two handles on the back. He carefully transfers the block to the surface of the paper where it is printed by pressure effected by means of a long wooden elbow that the printer pulls straight, so as to brace the block against the paper with a thrust of the wooden elbow against

*For notice of copyright, see page immediately following the title page*

the ceiling. The block, in printing, marks on the edge of the paper a guide so that the following block may be placed

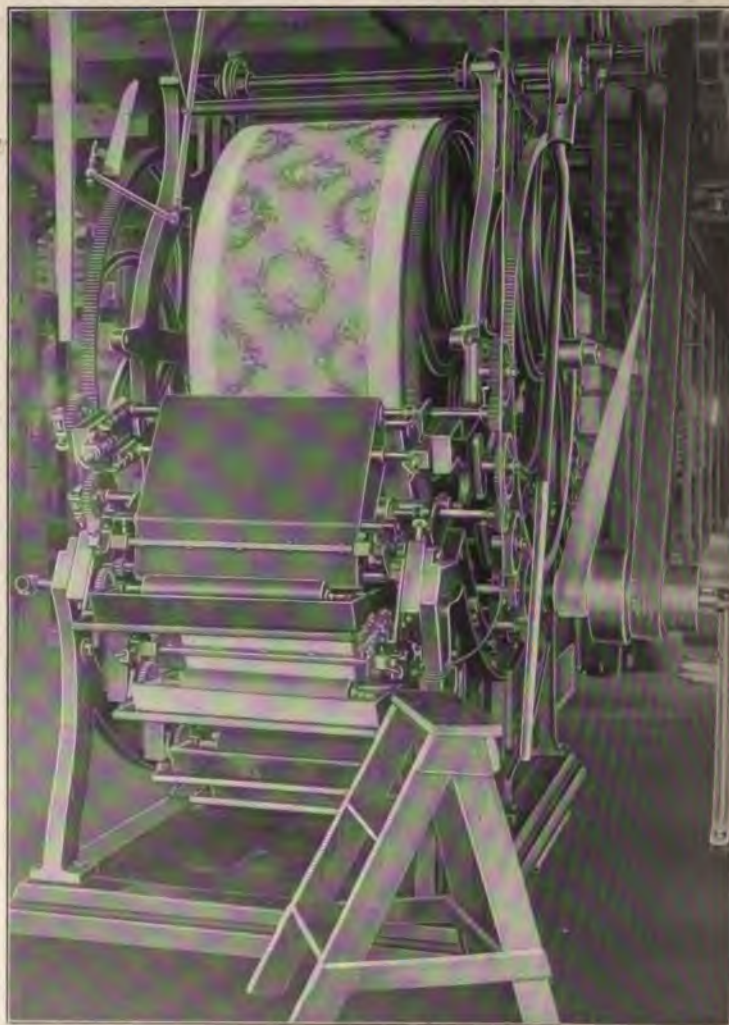

FIG. 1

so as to impress the second color in its proper place. As the block is printed, the paper is moved along one repeat and

carried over cross-bars, or sticks, in long loops or folds so as to dry thoroughly before it is rolled up to pass through the process again for the printing of the second color. Each color is thus applied successively until the entire surface of the paper is impressed with the design, and for each color applied the paper passes under the printer's hands and is impressed with a separate block.

Although the finest wallpapers are printed in this way, most of the hand-printed papers are imported from Europe. A few American manufacturers produce hand prints that compare very favorably with the imported article, but the price is so high and the demand for high-priced paper so limited, that most wallpaper designers in this country confine themselves to the preparation of designs for machinery production.

**3. Machine Printing.**—In machine printing, each section of color or tint is printed from a separate roller; while the paper moves around a large drum, Fig. 1, it

comes successively in contact with each color roller before the previous color has dried. This causes machine-printed papers to blend their colors and prevents the clean, sharp distinction of outline that is characteristic of the hand-printed



FIG. 2



papers. Some wallpapers are printed in two colors only—one the background and the other a diaper or other surface design—these are printed from a single roller as the background is printed by a separate machine. In Fig. 2 are shown several wallpaper rollers, each of which presents a complete design; whereas in Fig. 3 are shown a number of rollers where each



FIG. 3

presents but a fraction of the design, the entire twelve rollers being necessary to complete the pattern in its several colors.

**4. Method of Making the Rollers.**—A very important detail in the process of machine-printed paper is the preparation of the rollers so that they will exactly imprint all the details of the pattern in the successive colors and present a harmonious whole.

This work is executed by skilled workmen and is often a slow and tedious process. The rollers are made from maple logs turned exactly to the required size, which is regulated by the length of the repeat. Where a design

calls for a number of colors, each roller must be turned to exactly the same diameter, within the minutest fraction of an inch, before the design can be executed on its surface. After being turned to the required size, the

rollers are painted white, and, when dry, are given a traced impression of the entire pattern. Upon each roller is then marked its part of the pattern; and it is then given to the block cutter. The smallest details on these surfaces are made of solid pieces of brass, formed to the proper shape by being drawn through steel dies. These are then driven into the surface of the roller at the proper places. Circular dots, etc. are made of brass wire cut in pieces  $\frac{1}{2}$  inch or less in length, and with the sharpened end driven, with a hammer, into the roller at the required point. Larger surfaces are outlined with thin strips of brass that are skilfully filed and bent to the required forms, and then sharpened on the lower edge so as to be driven into the wood after the outline has been cut in with a knife or a chisel. This outline of brass is driven firmly and solidly into the wood, somewhat less than  $\frac{1}{4}$  inch of its length being left above the surface. When this work is complete, the spaces within these brass outlines are filled with heavy felt that has been soaked in hot glue. When the felt and glue dries, it forms a hard and perfectly solid printing surface within the brass outline.

The rollers are then placed on a lathe and trued up, or ground, to the finished diameter, which makes their circumference exactly equal to the repeat on the paper. When all the rollers have passed through these processes and are finished to the exact circumference, they are ready for the printing machine.

5. In Fig. 1 is shown a machine on which an eight-color ceiling paper is being printed. The paper is fed in at the bottom and on the opposite side of the machine, from whence it passes around a large drum, as shown, and comes in contact with the various color rollers, after which it passes off at the top of the machine with the paper completely printed.

The strip is then carried, in long loops, over a coil of steam pipes by means of which the colors are thoroughly dried before the paper reaches the opposite end of the long building, where it is rolled up by machinery and so cut that each roll contains exactly the same amount.

**6. Difference Between Hand-Printed and Machine-Printed Papers.**—Having considered the two methods of manufacture, let us observe the difference in the appearance of hand-made paper and machine-made paper. Compare Fig. 4 with Fig. 5 and observe that, while the details of the former are perfectly sharp and distinct, and probably



FIG. 4

determine accurately the appearance of the designer's originality, the tones are softened in Fig. 5 so that one blends into another very much as in ordinary water-color painting; these facts should be taken into consideration by the designer. Where the design is of a severely conventional character, sharp distinctness being required between the

THE  
PUEB  
TH





FIG. 6

8 \$ 10

THE  
PUB

ART

several figures, he should prepare his design for the hand process, but where he requires a particularly realistic effect—a blending of natural forms one into the other, a softness of



FIG. 5

detail that leads the eye from one color to another without any definite point of transition—the machine-printed paper will give better satisfaction.

**7. The Colors.**—The colors with which the printing is done are composed of a mixture of the required pigment



ground in water and thickened with glue and dextrine. They must be of such consistency that they do not blur or blend one into another to any great extent, and at the same time they must be thin enough to flow readily from the surface of the felt belts and properly cover the rollers.

The colors are supplied to each roller by means of felt belts that are so adjusted that they pass through troughs containing the color and distribute it accurately to the printing rollers so that each receives just the proper amount. This is determined by experiment, as the belts are readily adjusted to change the amount of color being fed, and should it be found that as the paper passes through the machine too much or too little is being distributed, the belts can be adjusted in position so as to vary the amount.

It is evident, too, that as the amount of color can be varied as it is distributed on the rollers, and that the amount of blurring and softness of effect can be regulated by the quantity of size or glue that is mixed with it, quite a variety of effects in design can be obtained where the designer understands the possibilities of these color mixtures in manufacturing details. In many machine-printed papers that possess a number of colors, this blurring is very conspicuous and is frequently a means of rendering the paper more interesting than it would be where each detail was in sharp outline.

A designer, however, should always bear in mind that his design must be executed so that a distinct outline can be observed between each color and its neighbor. His mental conception of the finished paper may be one of softness and freedom from graduation from one part into another, but his execution of the design must not show any uncertainty as to where one color stops and another begins. If such uncertainty exists, the block cutters will never be able to get the repeats of their patterns cut accurately. All shading from one part into another is accomplished by means of planes of color, or gradual steps from one tone into another, as shown in Fig. 6, which is a reproduction of a student's exercise, and should be practiced repeatedly with different forms.



FIG. 7.

It is absolutely necessary for the designer to be thoroughly familiar with this technique as well as with the details of manufacture, for on this depends the practical value of the paper, and, outside of its merit as to design, its entire selling quality. The character of this technique can best be obtained by copying examples of any good designs. Hand-printed papers are admirable for this work when they can be obtained, and, when they cannot, it is best to use as copy some good quality of printed cotton goods, such as cretonne



FIG. 8

or sateen, as in most of these goods the printing is much more clearly defined than on machine-printed paper. The student, after practicing these copies, should endeavor to translate some floral form from nature into a suitable wallpaper design, and where floral forms cannot be obtained, photographs of them are next to be desired, such as is shown in Fig. 7. In practicing all these exercises, as well as in making practical designs for wallpaper printing, it is best to proceed in the order of the depth of the tone, painting the

lightest masses first and proceeding in the order of their depth to the darkest until the whole pattern is finished.

For instance, the tone *a* in Fig. 8 would be the first one painted; it might extend over the entire form of the leaf and the darker tones be placed over it, but this is hardly necessary, as it can be carried a slight distance under the limits of the tone *b*, while *b*, when laid, can be carried a short distance under the tone *c*, and *c* under *d*. When the design is executed on the printing machine, this is the order in which it will be printed to produce the most desirable effect, as it can be seen that should there be a slight discrepancy in the register between these colors, the darker color will obliterate the lighter one, and thereby present a more even appearance than if a light color overlapped a dark one and caused a grayish tone in the outlines. Therefore, if the designer observes this rule in preparing his design, he will find that much trouble will be saved in its reproduction and his ability will be much appreciated therefor by the manufacturer. Very small high lights are usually painted on top of other water colors for convenience, but it is best to leave these in painting the dark colors, as it adds materially to the convenience of the color printers.

Where an outline is used to distinctly emphasize the edges of the form it is better that it should be dark, for light outlines do not clearly express themselves.

When gold is used on a design, it should be arranged so as to fall entirely clear of any color, and whether executed as an outline to some form or in masses, it should be distinct in its own particular shape so that there may be no difficulty in getting the block that is to determine its printing on the wallpaper. Gold is not printed directly from a roller, as are the colors, but as the paper passes through the printing machine, the last roller with which it comes in contact impresses its design on the general surface in varnish that is much slower drying than the water colors with which the rest of the paper is printed. After all the water color has dried, this sizing of varnish is still sticky, and gold or bronze powder sifted over the paper will adhere to this

sizing while it may be brushed off the rest of the paper. It is evident, therefore, that there must be distinctness of outline so that the surface covered by this varnish may be clearly determined and may not overlap any of the forms that are to be executed in the water color.

---

### PREPARING THE DESIGN

**8. Laying Out the Design.**—Assuming that the width of a repeat of the wallpaper has been determined to be 18 inches, the designer first considers the lengths of repeats that are most convenient in ordinary reproduction; these are  $11\frac{7}{8}$  inches,  $12\frac{3}{4}$  inches,  $14\frac{3}{4}$  inches,  $17\frac{3}{4}$  inches,  $18\frac{3}{4}$  inches,  $21\frac{3}{4}$  inches, and  $23\frac{3}{4}$  inches. He then lays off the required dimensions of the width of the paper and the repeat, in the center of a large sheet of Manila or brown-detail paper, leaving an 8-inch or 10-inch margin all around the design. This margin permits sufficient freedom for the designer to draw in his general idea and indicate a portion of the repeat of all four sides. This large surface can be considered as a portion of the wall on which the designer is then arranging his paper. The leading lines should be sketched in with crayon or charcoal passing throughout the repeat to the very limits of the paper unless the design is to be composed of small geometrical figures, when the general effect of the design can be observed in smaller compass.

If charcoal is used and the lines are sketched very lightly at first, they can be easily erased, in order to make changes, by means of a small piece of chamois leather; if crayon is used, the lines may be erased with a piece of rye bread.

The arrangement of a large floral design, such as shown in Fig. 9, requires much thought and study in order to arrive at a fixed and satisfactory composition. A designer very rarely conceives a whole pattern in detail before executing part of it on paper. He may picture before his mind a few leading lines and general effects of floral forms that he is desirous of using, and he may have a mental picture of



FIG. 9

whether the finished pattern is to present an all-over, a spotted, or a powdered effect, but his ideas may change as he works up the design, for as he pursues his way in his first preliminary sketches, new suggestions will come to him as the lines multiply and the general structure of the design is mapped out.

After thus beginning it is comparatively easy to alter and work out the structural lines until they are pleasing, and the details can still more easily be supplied. The designer should



FIG. 10

never attempt the slightest detail, however, until he is thoroughly satisfied with the general character of his composition.

As objectionable spotting or lining cannot be easily determined when the drawing is in outline only, the general forms should be darkened or spotted by means of charcoal or crayon, as shown in Fig. 10, where a dandelion has been conventionalized and taken as the motive.

By this method of procedure, the design has practically been proved on the wall surface before any of its details are elaborated. This avoids much waste of time and is the only safe way for a beginner; for the composition that is



FIG. 11

commenced with detail and worked into structural principles afterwards is almost invariably a weak design that is unsatisfactory and unsalable. Detail takes time, and when



it is fully drawn out at first, one rarely has the patience and determination to rub out the unsatisfactory elaborations and to do the work over again to eliminate the faulty points. Therefore, every designer making repeating patterns, should have before his mind constantly the following rule: *Never draw an elaborate detail before knowing exactly where each part of it should be placed.*

When the satisfactory arrangement of the general repeat and the adjustment of the forms are determined, the detail of one complete repeat of the design should be drawn within the outlines of the original plot that was laid in the center of the paper. Where important forms are cut in two by the lines of the repeat, as is the case in the design shown in Fig. 9, the entire form should be drawn at that point to insure absolutely perfect matching when the design is repeated. Fig. 10 is from a working drawing rendered in water colors by a student of the Ecole Guerin at Paris. It is an arrangement of poppies and their leaves decoratively treated and cleverly grouped in strong masses on a drop-pattern repeat. The entire composition is bold and simple, the strong effect being obtained absolutely by means of flat washes of color. In Fig. 11 is shown a design based on the conventionalized form of the closed gentian. The trumpet flower is similarly treated in Fig. 12 and the Zinnia in Fig. 13, while the arrow-head is shown in Fig. 14. These designs were executed by students of the School of Industrial Art at Philadelphia, and show to what extent simple forms may be conventionalized from the natural objects.

**9. Making the Working Drawings.**—In designing wallpaper, the color scheme should first be tried, to determine its value and the effect. After this has been finally decided and the working drawing is entirely completed, the design should be transferred for its final painting to a sheet of stretched drawing paper that has been coated with a background color. If the design is a large one, such as shown in Fig. 9, at least 3 or 4 inches should be shown beyond the repeat on all sides, while with smaller designs a



FIG. 12

number of complete repeats should be worked out. The stretched drawing paper on which the working drawing is executed should be large enough to permit a clear margin of at least 4 inches all around the finished design. Some designers



FIG. 14

make a margin of 6 or 8 inches on large patterns, and render this margin in a flat color that harmonizes or contrasts agreeably with the color scheme of the design itself. This border serves the simple purpose of framing the picture. The effect is still more striking when the design is separated from this border by a heavy line of contrasting tone or color that is lighter or darker than the border itself, as the case may require. The object of this should be obvious. It is the designer's desire and intention to show his work to the best advantage in submitting it for sale; and any detail that he can add to his finished design that will make it more presentable, is a perfectly legitimate way to commend his efforts to the attention of the prospective purchaser. Neat, accurate work is absolutely necessary. The color scheme should be definitely determined on before the final painting is commenced.

make a margin of 6 or 8 inches on large patterns, and render this margin in a flat color that harmonizes or contrasts agreeably with the color scheme of the design itself. This border serves the simple purpose of framing the picture. The effect is still more striking when the design is separated from this border by a heavy line of contrasting tone or color that is lighter or darker than the border itself, as the case may require. The object of this should be obvious. It is the designer's desire and intention to show his work to the best advantage in submitting it for sale; and any detail that he can add to his finished design that will make it more presentable, is a perfectly legitimate way to commend his efforts to the attention of the



FIG. 13

paper, and every form of economy in printing a design is a point in favor of the designer.

**11. Prices Paid for Designs.**—The prices paid for designs vary from \$20 to \$50 for each single pattern; combination patterns of ceiling, frieze, and side wall are worth from \$50 to \$60, according to the design. The cheaper grades of paper are usually produced in sets of three pieces, but the more expensive ones are produced only as side-wall papers, or occasionally in combination of side wall and frieze.

Fig. 4 is reproduced directly from a design executed by a prominent wallpaper designer of Paris, and purchased from him by a Philadelphia firm. In effect, it is a tapestry design of the period of Louis XIV, arranged in 18-inch repeats as a drop pattern. It contains twelve colors very skillfully placed so that each touch of color is very clearly defined.

In Fig. 5 is shown a piece of printed wallpaper that, compared with the design in Fig. 4, gives a clear idea of the comparative amount of surface that must be covered in the original design in order to insure the proper repeat in the finished article. In running this pattern on the machine, twelve arrangements of color are produced in order to suit the varying conditions and demands of the public taste. The original design was executed in several tones of olive, blue, brown, and red, as marked on the rolls in Fig. 3. The network of black lines that gives the finished paper the appearance of woven tapestry was applied after the design was completed on the wallpaper printing machine by another machine used exclusively for this purpose. These lines are not indicated on the original design, as each manufacturer usually possesses a variety of rollers that give any desired tapestry effect.

The price paid for the design in Fig. 4 was \$40, but the cost of preparing the rolls and other details for its printing possibly exceeded \$500 before one roll of the finished product could be taken from the machine.

**12. Forecasting Styles.**—The immense expense incurred in reproducing a design requires that the buyer of

the wallpaper manufacturing company be particularly careful in the selection of his patterns. There is always an uncertainty as to the tenor of public feeling, and even the experienced design buyer cannot tell in advance whether his judgment is going to bring profit or loss.

Men with years of experience draw their own conclusions and make prophecies as to the popularity and failure of certain styles, and these conclusions usually determine whether they will purchase or reject certain designs submitted to them. The designer, therefore, must not consider that the refusal of his design always indicates its unsuitability or impracticability or lack of merit, as the wallpaper-design buyer is influenced by many more things than artistic merit. He knows more of the public taste than the designer, and he determines by a judgment that amounts almost to intuition, what is destined to become a good seller in the wallpaper market and what is not destined to become popular in the public eye. These are the details that to him determine the value of a design.

It may be well to quote in this connection an editorial that appeared in the *Wallpaper News and Interior Decorator*: "It is sometimes possible to tell in advance what general styles of wallpaper will be popular during a coming season, but it was never more difficult than this season. The reason for this is that there will probably be a greater variety of popular goods than ever before. The old oriental tapestry that had such a run has given place to a wide variety of fabric effects of different kinds. Crown effects are being employed in many different ways. Panelings are found in every line this year.

"There seems to be a revival of interest in Gothic, especially in furniture, and wallpaper and other furnishings usually follow the lead of furniture. The "Mission" style of furniture was rather severe, and though the Gothic is built on the same straight lines it is more decorative and hence better suited to our modern taste.

"As far as wallpapers are concerned there is little Gothic on the market, and designers and manufacturers at the

present time would do well to suit the style. Tapestry and heraldic effects come probably the nearest to Gothic. What one should consider is that there is a demand for something that will harmonize with the beautiful Gothic furniture that is now being placed on the market."

From this, the student will see that much valuable information can be obtained by reading the trade papers that deal with the subjects of wallpaper and furniture design or interior decoration. Such hints as the foregoing are invaluable when obtained in time, and a comparison of the facts set forth in this editorial quoted above with the new styles that appear in the following seasons indicates somewhat that the trade papers keep in touch with what is about to be done.

**13.** Following the foregoing description of prevailing styles and coming styles, Fig. 15 shows a design representing the crown effect characteristic of the French style, dividing the wall into panels crowned by masses of flowers. Fig. 16 shows a panel effect on the side wall over which is placed a conventional landscape frieze that makes a very effective design for a severely conventional room, such as a library, and one in which severe Gothic furniture can be placed with great satisfaction. In Fig. 17 a strong effect is obtained by arranging the Louis XIV tapestry, shown in Fig. 5, in a panel with a specially designed border, showing what can be accomplished by using existing styles for severely conventional wall treatment when specially designed styles to suit certain conditions do not already exist.

---

#### PRINCIPLES OF WALL DECORATION

**14.** While all six sides of a room must be carefully considered in preparing the general decorative scheme, the four side walls and ceiling will admit of much more liberal and free treatment than the floor. The side walls of a room must usually be considered as a background to the other fittings; were this not the case, any reasonable type or

element of design might be represented in the decoration. As a usual thing, the side walls and their decoration must be considered in connection with the furniture, carpets, hangings,



FIG. 15

pictures, and other elements of the furnishings. Therefore, a conspicuous floral pattern is always bad. Such designs can never hold one's interest long. The senses



soon become weary of them and after a while the presence of its self-asserting decorative elements becomes positively irritating and annoying.

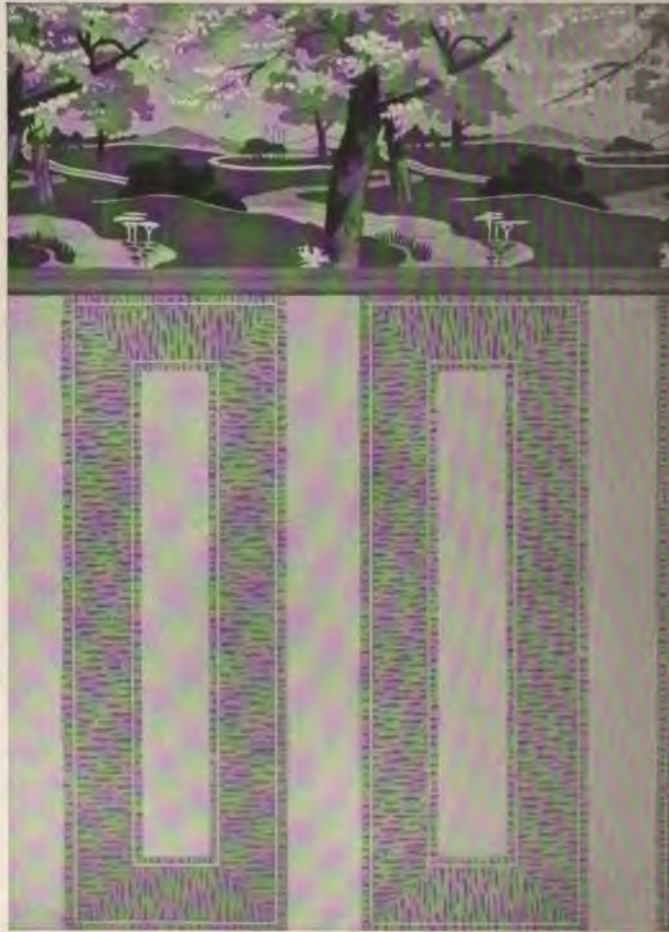

FIG. 16

Designs for wall decoration can be cheerful and even gay, but they should never be boisterous. The public's constant demand for novelty leads the designer to execute exaggerated floral effects with the idea of attracting the public

eye and making the paper salable; but such designs are popular on the market for but a short time, for when they are imposed on people of refined tastes their production is soon discontinued. The effect of novelty can be easily satisfied within the bounds of good taste, and it is the



FIG. 17

realization of this fact that enables the French and the English designers to create patterns that are more eagerly sought by American manufacturers than are the usual American patterns. The foreign designers have become better

acquainted with the principles of artistic design; and, while they are producing quite as many novelties as American designers, they confine these novelties within the bounds of good taste. These designers command suitable prices, and at the same time educate the people that use their designs to appreciate the value of good work, and thereby raise



FIG. 18

the artistic standard of the entire community. It is but a few years since decorative art has been systematically taught in this country, and American designers should soon compete with, if not excel, on equal grounds, their foreign competitors. The art schools throughout the country are teaching hundreds of students to design properly. The best manufacturers in the country are printing hundreds of designs every year that are educating the people to a higher

standard of art. The time, therefore, should not be far distant when none but good designs will be accepted by the mass of the people, no matter whether they are made by Americans or Europeans, or whether they are high-priced or low-priced; for a principle of good design can be applied to paper costing 25 cents per roll just as well as to paper costing \$2.50 per roll.

It is every designer's duty, no matter what may be his branch of art, always to do the best he can and never give to the public or to his client a design of which he cannot approve. If the people to whom he is catering possess vulgar taste, it is his duty to educate them by giving them good designs, for as soon as their taste becomes refined they will accept none but the best, and if he has been in the habit of giving them inartistic designs, they will abandon him as soon as they know better.

The paper hanger of the present day is frequently the middle man between the manufacturer and the purchaser. He presents to his customers a few styles from which is selected the paper that will be hung in a room; if he possesses no taste, his selection of papers tends to degrade the taste of his clients or to prevent their advancement in artistic ideas. It is as much the paper hanger's duty to become educated in design as it is the designer's, but when so educated he usually terms himself an interior decorator. He dictates largely to the tastes of the people and creates a demand on the manufacturers and designers; therefore, the designer should use every endeavor to improve the taste of the paper hanger in order that his own advanced ideas may be appreciated by the public. Owen Jones, a well-known writer, in "Grammar of Ornament" states: "No improvement can take place in the art and taste of the present generation until all classes, including artists, manufacturers, and the general public, are well educated in art and the existence of general principles is fully recognized."

**15. Varying Tastes of Different Localities.**—In some sections of this country there is a lingering fondness

for the Colonial style of architecture. In other sections the Colonial style has been revived after other styles have been tried and abandoned. During the few years immediately following the Spanish-American War, public taste took a decided trend to the Spanish styles of decoration; all of these are suggestions to the designer and interior decorator of the styles he should study in order to satisfy public taste without producing incongruous combinations. With the revival of the Colonial style of architecture, certain enterprising manufacturers incurred considerable expense to carefully uncover some of the ancient papers on the walls of old Colonial houses and to employ designers to prepare exact reproductions of them. The enterprising designer makes himself so familiar with the prevailing styles that he can produce new and original designs in the spirit of the old style. Copies of antique patterns are not new designs, and the designer who permits himself to degenerate to the copyist cannot expect to advance in his profession.

Fig. 18 is a design worked by a student from a piece of 16th century Italian arabesque; Fig. 19 is a pattern worked out by a student, the original idea of which was taken from the embroidery on a priest's robe made in the 16th century.

In Figs. 20 and 21 are shown two patterns that can be classed in the Colonial style; characteristic of these daintily colored stripes were bouquets or garlands of flowers in imitation of the old brocades. In modern work, these patterns are imitated occasionally in cretonnes and are singularly appropriate for this style of wall decoration. Fig. 20 is from the French hand-printed paper, while Fig. 21 is a design by a student taken from a piece of old silk in the Pennsylvania Museum. This adoption of old silk and tapestry designs to modern wallpaper is frequently made by designers in producing patterns in very historic styles, and is of particular value when it is necessary to give various cloth and tapestry effects.

**16. Designs for Special Rooms.**—The demand for designs suitable to special rooms is becoming more and



FIG. 19

more marked. People of wealth frequently order special wall coverings made exclusively for their own houses, and as the middle class of people endeavors to imitate the tastes and manners of the wealthier classes, it is necessary that the designer should endeavor to please this class, for the manufacturers depend on the middle class for the sale of the bulk of their goods. This tendency is the cause of the existence of such designs as the crown frieze, paneling in imitation of wood or leather, etc. These designs have been properly applied and appropriated to a room, giving them much the appearance of having been designed to fit that especial room, and consequently are sought after by persons that desire these individual effects in imitation of the wealthier classes.

The designer and the interior decorator must have a definite idea as to the kind of pattern that is appropriate for an individual room. The former must be able to invent, and the latter to select, designs suitable to the different rooms of an ordinary house, from the parlor to the kitchen and bath.

**17. Classification of Wallpapers.**—The manufacturer classes his various papers under headings that represent the rooms for which they are appropriate, and he endeavors to have as wide a variety as possible in the several designs included in each class. In the average city house, there should be sufficient contrast and harmony of tone and design from one room to another to prevent a feeling of monotony, as one goes through the house, without too great an impression of variety; the following styles are suggested as appropriate:

1. *The Hall.*—The hall should be rich and cheerful in color though not necessarily brilliant, unless the hall is very dark. The pattern should be old but subdued in effect; it should be dignified and rather pretentious in drawing, severely conventional, suggestive of direct mural paintings in panels, or of cloth or tapestry effects.

2. *The Parlor or Drawing Room.*—The parlor or drawing room should be stately and pretentious in its pattern but in

coloring more delicate than the hall; the tints should be lighter. Renaissance scrolls are frequently employed in rich embossed effects as are also suggestions of materials such as silk, velvet, etc. However, many dainty naturalistic effects are used in parlor decoration, particularly in small houses. The parlor or drawing room is essentially an assembly room for stage or dress occasions; it is used almost exclusively in the evenings and its paper should be considered so as to delicately harmonize with the suggestiveness of evening dress and dainty surroundings. It is usually the most pretentious room in the house and calls for an excellent quality of goods, showing skilful and chaste, rather than old and aggressive, designs. The ceiling should usually be papered in plain tints or hand-decorated in distemper.

3. *The Dining Room.*—The dining room should be cheerful in color and designed rather architecturally in subdivision, with a plain dado in wood or panel effect and fanciful frieze in tapestry effect with landscapes or figures. The side wall between the dado and frieze may be in plain colors or in panels, but when panels are used in the side walls they should be avoided in the dado. The entire side wall may be omitted in the frieze treatment and its panels may be extended entirely to the ceiling, filling them completely with a tapestry effect repeated at intervals. The ceiling is often left plain or rendered in distemper to harmonize with the side-wall treatment, or it may be papered suggestive of wood paneling or embossed leather. Frequently a bronze effect is attempted, tufted at intervals with metallic buttons.

4. *The Library.*—The library should be rich but subdued in color, in tapestry or fabric effects if possible, and in any case suitable to the style of furnishings; of these the prevailing taste is Gothic, Italian, Renaissance, Flemish, Elizabethan, Empire, etc. Other rooms on the first floor of the house are usually morning rooms, reception rooms, or, possibly, breakfast rooms, each of which should be rather more delicate in furnishing than the parlor and dining room, as they are essentially rooms that are used in daytime and



their decorative elements should be so considered. Papers are seldom specially designed for the three last-named rooms, but the decorator is frequently called on to make selections for them and his judgment should be governed accordingly.

5. *The Kitchen.*—The essential point in a kitchen wall covering is utility, something that will reflect much light



FIG. 20

and keep clean. The ideal wall covering for a kitchen would be tiles or enamel brick; therefore, wallpaper patterns that are geometrical in design, suggestive of tile or brickwork, are entirely suitable, and designs of this character can be obtained in varnished papers, which are washable and can be kept nearly as smooth and clean as tile itself.

6. *Bedrooms.*—Bedrooms should contain delicate bright

designs in cheerful decorative or naturalistic patterns of flowers. Stripe effects with floral details, such as are shown in Figs. 20 and 21, are exceedingly popular, but the frieze treatment should always be included, as the appearance of the stripes running from the ceiling to the floor is decidedly distasteful.

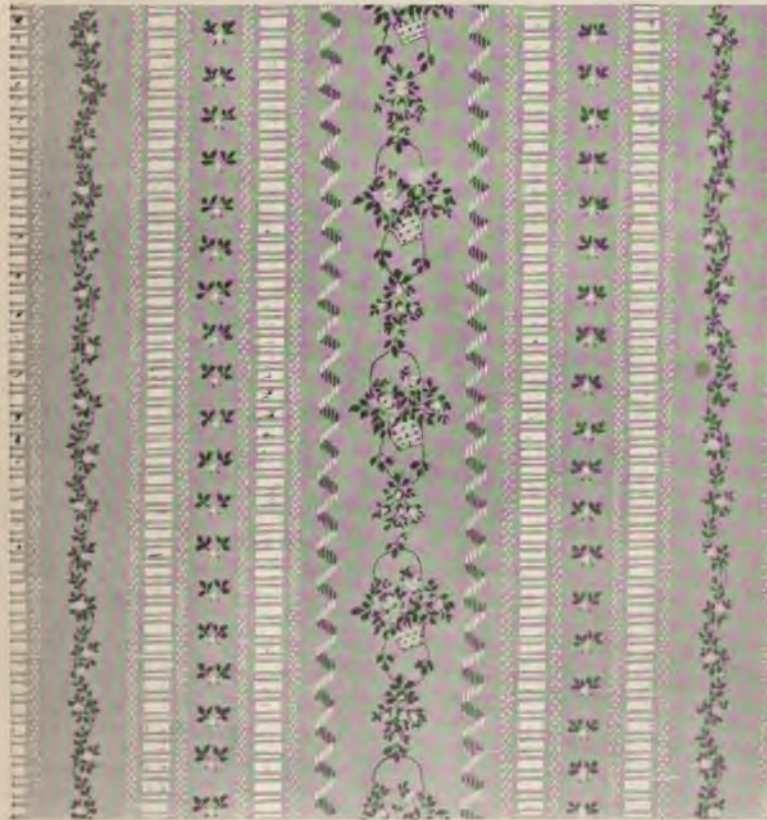

FIG. 21

An exceedingly popular treatment for bedrooms and sitting rooms consists of a subdivision of the wall into three parts, the lower two-thirds of which is covered with a plain tint or two-tone stripe, and the upper parts with a rather large and

brilliantly designed floral pattern. A two-tone green stripe for the lower portion with a poppy frieze is very popular for bedrooms, as poppies are symbolic of sleep. But other



FIG. 22

combinations can be used, such as a two-tone yellow under a frieze of lilacs or Wistaria.

7. *Children's bedrooms* have been given special attention by the designer and the decorator. Considerations of the

lively imagination that children possess have been expressed in wallpaper design, as the child mind is likely to convert everything about it into a topic of conversation or wonder;

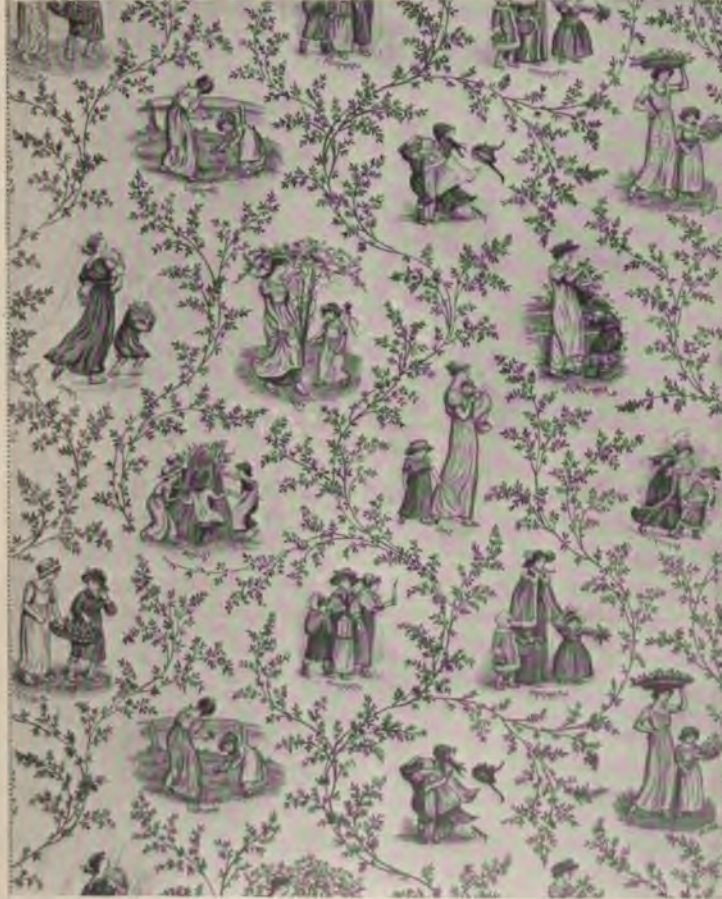

FIG. 23

therefore, to please these infant fancies the English manufacturer has reproduced illustrations of Mother Goose melodies in a wallpaper pattern, which is reproduced in Fig. 22; while in Fig. 23 is a design indicative of the different months of the year, suggested by drawings by Kate Greenway. The

propriety of these elements in wallpaper design, from an artistic standpoint, is hardly to be considered, since the decorative element in this case is subordinated to the educational and recreative element that must exist in the nursery.

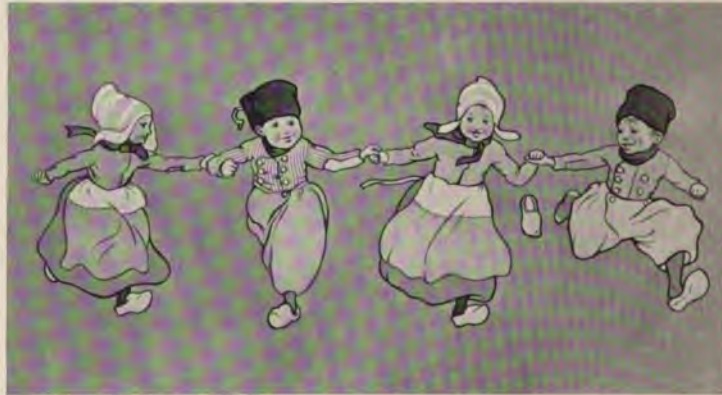

FIG. 24

A more decorative treatment is shown in Fig. 24, which is a wallpaper pattern entitled Snapping the Whip. Nothing could be jollier or merrier than this continuous series about the nursery walls, repeating, as it does, the same individual



FIG. 25

every fourth figure, and an immense field of decorative design is opened up by these suggestions. Another design of the same character is shown in Fig. 25; it portrays characters from the story of The Pied Piper of Hamelin.

**18. Freedom in Choice of Designs.**—The process of manufacture of wallpapers imposes very little restraint on the designer. He is free to adopt any idea or type for the subject of his design, and to this excessive license is due the existence of many exceedingly inartistic patterns that are perpetrated in the name of wall coverings.

There is probably no branch of design that permits the craftsman to enter so unrestrainedly into naturalistic patterns as wall decoration. Such patterns are not difficult for the manufacturer to reproduce. The paper hanger buys them and thereby makes them good sellers, and uneducated people purchase them because the flowers look "so natural," without considering whether this naturalistic appearance is an element of good design or not. The French and American designers are most largely responsible for this class of work, for among them are found many clever craftsmen who allow their skill to eclipse their good taste. The patterns invented by the French are exceedingly elaborate and the execution of the work is of marvelous excellence.

Fig. 26 illustrates an elaborate French pattern that required thirty-five impressions to reproduce. French designs are used to a large extent by American designers in the following manner: An elaborate pattern, such as that shown in Fig. 26, is copied and simplified in color and detail so that a fair reproduction of it may be printed in less than half the original number of colors. Thus the hand-printed paper of France becomes the machine-printed paper of America. This may seem easy at first, but it requires much ingenuity and is usually the work of a large class of craftsmen who are clever in execution but who possess little inventive ability and power to originate new designs.

Fig. 27 is an American design, printed by a New York firm, using twelve colors on a plain white ribbed paper, in the form of a spot pattern composed of bunches of pink primroses and cream-colored narcissus. This is a side-to-side repeat of two distinct groups of flowers forming alternate horizontal bands. Each repeat is arranged



FIG. 26



FIG. 27



within a space 18 inches by  $21\frac{7}{8}$  inches. This pattern is an example of the style of naturalistic treatment that should be studiously avoided by the beginner. The best critics characterize this style of rendering as bunches of flowers thrown



FIG. 28

at the wall. They have the appearance of cut flowers and their separate stems are painfully evident. It should be borne in mind that the delicate portrayal of a series of branches over the entire wall is likely to become monotonous. The side walls of the room would be inappropriate

for such delicate details in reality; therefore, the real appearance of the flowers should be avoided and they should be rendered with delicate conventional treatment that does not pretend to be a counterfeit of nature. Where a naturalistic rendering is attempted, a treatment like that shown in Fig. 28 is much more suitable. This is a French hand print, and the effect produced is that of a mass of green foliage entirely covering the wall, emphasized here and there by spots of sunlight and bunches of brilliant blossoms. The idea indicated in this pattern can be carried out to an almost unlimited extent with any other plant growth without in any way violating any strict principles of design or of the nature of the growth.

Rococo effects in connection with naturalistic flowers, Fig. 15, have always been popular, particularly in cheap papers with plenty of gold. These suit the taste of a certain class of people, and together with certain gaudy floral patterns they find a ready sale in the decorative treatment of small houses that are built by the block and literally papered by the wholesale. They form easy patterns for the paper hanger to select, and usually suit a class of people that look for brilliancy rather than harmony of effect. The best way to overcome the demand for such patterns is to educate the people to appreciate better and simpler patterns.

The scale of the pattern and the repeat should undoubtedly be in accordance with the size of the room in which they are to appear. A large pattern, such as shown in Fig. 9, though entirely appropriate and harmonious in a large room, would be greatly out of place in the ordinary living rooms of a small house.

In Fig. 29 is shown a French pattern designed for the market in 1904, and though not extreme in design possesses no great dignity or originality. The color effect, however, is very pleasing and there is little tendency for it to become monotonous, as the design is so severely conventional. Fig. 30, another design from the same source, consists of an almost childish conception of a mixture of tree



FIG. 29

foliage and huge sunflowers, and a variety of small flowers and grasses in conventional perspective.

Exaggerated floral effects, such as prevailed in French designs a few years ago, are fast disappearing, and public taste seems to be gradually improving.



FIG. 30

**19. Examples of Prevailing Styles.**—Effects in single color or two or more tones are apparently much more in demand now, and English designs are undoubtedly far in advance, in taste and artistic merits, of most of the French or American patterns. Fig. 31 shows a pattern, called *Courtland*, which is an English hand print.



FIG. 31

This is an arrangement of decorative lilies and leaf scrolls, rendered in a color scheme composed of blue and green-gray with a touch of dull yellow in stems and stamens. There are several impressions in all and the pattern is very skilfully treated. The flowers are very large, the original measuring more than 8 inches across, and the color rendering is so delicate that it makes a perfectly satisfactory wall covering and an excellent background, possessing not a harsh line or conspicuous tone. In Fig. 32 is an English lithographed wallpaper in graded tones of red, green, yellow, and brown, in which an effect is obtained as though it were executed by hand. This is an effect obtained in lithographed papers only.

In some of the higher-grade papers, stencil plates are used and the colors are applied with a brush, the harsh outlines being removed while the color is still wet, after the plate has been lifted. The effect of this is to produce a paper where the colors are graduated one into another, similar to that shown in Fig. 32. But these results are obtained only after great expense and tedious manipulation.

#### **20. Designer Must Be Observant of Public Wants.**

The successful designer must keep in touch with the times, must be constantly alert for suggestions, must observe foreign patterns that use particular processes, and endeavor to work up similar patterns suitable to American processes. Manufacturers work up their designs a year or more in advance of the market. In August of each year, the wallpaper men gather in New York to show their new goods to sell to jobbers all over the eastern part of the country. Sometimes, later in the year, they gather in other large cities for a similar purpose, and all experimental patterns must be out for execution at that time. Prevailing indications of modern treatments suggest: First, different developments of the crown frieze effect popular at the present time, executed both in natural growth and in conventional and decorative floral and landscape arrangements; second, decorative series, consisting of frieze, landscapes, etc., in

imitation of mural paintings; third, small conventional diaper patterns in fabric effects with borders to match. New designs for cheaper patterns in entire sets will be in demand as usual; the styles of these remain about the same.



FIG. 32

The designer should always consult his local dealer, look over his newest stock, and make every effort to learn what is being done in the designing world. Those situated in large cities have an advantage on account of the greater

variety displayed, and the opportunity of observing the latest novelties and finest goods.

The experienced designer would do well, when convenient, to submit his designs to some local dealer, explaining his idea of the use of the design and asking advice as to a probable buyer among manufacturers. The designer must be particularly sure before submitting a design for sale that it is technically correct for reproduction. No matter how good a design is it will not be accepted if it cannot be printed, as manufacturers have no time to redraw patterns. Certain advice from a manufacturer or an established designer would be most valuable, but it is not easily obtained even in communities where both manufacturers and designers abound. The former are usually too busy to enter into details, and the latter, jealous of their calling, are not anxious to explain the facts. But occasionally a wallpaper manufacturer will observe merit in a designer's work, although he is not anxious to purchase the design, and will suggest to the designer lines whereon he should work in order to arrive at more popular results.



1

2

3

4

5

6

7

8

9

10

11

12

13

14

15

16

17

18

19

20

21

22

23

24

25

26

27

28

29

30

31

32

33

34

35

THE  
AMERICAN VIGNOLA

---

PART 1  
THE FIVE ORDERS

---

BY WILLIAM R. WARE

FORMERLY PROFESSOR OF ARCHITECTURE IN MASSACHUSETTS INSTITUTE OF  
TECHNOLOGY AND IN COLUMBIA UNIVERSITY

THIRD EDITION

---

SCRANTON  
INTERNATIONAL TEXTBOOK COMPANY  
1904

## NOTICE

The elements of architecture according to the proportions first established by the Italian architect, Giacomo Barozzi da Vignola, in the year 1563, have become identified with that writer's name, so that at the present time the term "*Vignola*" is almost universally used to indicate a treatise on the five orders of Classic Architecture. This Instruction Paper is a reprint of Part I of *The American Vignola*, prepared by Professor Ware for the especial use of American students.

Copyright, 1902, by WILLIAM R. WARE

---

Copyright, 1904, by INTERNATIONAL TEXTBOOK COMPANY

---

All rights reserved

## PREFACE TO THIRD EDITION

---

This edition of "The American Vignola" is a reprint of the first and second editions, with a few changes and extensions of the text suggested by the author. The text illustrations have been redrawn, and have been enlarged so as to be of more practical value to the student. The volume has been reduced to octavo size, and the plates have been inserted on guards. It is hoped that the advantages gained by these changes will be apparent to those students for whom this book is especially published, and that suggestions for further improvement will be submitted to the publishers as they may occur to the reader.

INTERNATIONAL TEXTBOOK COMPANY.

---

## PREFACE TO FIRST EDITION

---

In January, 1859, I went from Mr. Edward Cabot's office in Boston, where I had been for two or three years, to join the little company of half a dozen young men who were studying architecture in the Studio Building in Tenth Street, under the inspiration of Mr. Richard Hunt. Mr. Hunt had just returned from Paris and was eager to impart to younger men, though we were not much his juniors, what he had learned in the *École des Beaux-Arts* and in work upon the New Louvre. We had all, I believe, had more or less of office experience, but those were the days when the Gothic Revival was at its height, and Mr. Hunt found most of us unfamiliar with Classical details and quite unskilled in their use. I, at any rate, knew hardly a touch of them, and I remember well the day when, as I was carefully drawing out a Doric Capital according to the measurements given in my *Vignola*, Mr. Hunt took the pencil out of my hand and, setting aside the whole apparatus of *Modules* and *Minutes*,

showed me how to divide the height of my Capital into thirds, and those into thirds, and those again into thirds, thus getting the sixths, ninths, eighteenth, twenty-sevenths and fifty-fourths of a Diameter which the rules required, without employing any larger divisor than two or three.

It seemed as if this method, so handy with the Doric Capital, might be applied to other things, and I forthwith set myself to studying the details of all the Orders, and to devising for my own use simple rules for drawing them out. The present work presents the results of these endeavors. Experience in the class-room has, meanwhile, amplified and extended them, and they have at many points been improved by the suggestions of my colleagues.

I am particularly indebted to Professor Hamlin and to Mr. W. T. Partridge for some ingenious applications of the 45-degree line to the Doric Entablature and to the Corinthian Capital, and for an analogous employment of the 60-degree line.

Finding that the plates in which, for the convenience of my own students, I have embodied these results are somewhat in demand by others, I now publish them in the present volume, adding such text and marginal illustrations as the subject matter seems to require. The plates have been drawn out for me anew by Mr. Partridge, as have also most of the Illustrations. The rest have been taken from standard publications, especially from Bühlmann's "*Architecture of Classical Antiquity and the Renaissance*," which has furnished twenty-six of the figures.

The forms and proportions here set forth are, in the main, those worked out by Giacomo Barozzi da Vignola and first published by him at Rome in the year 1563, as those which, in his judgment, best embodied the best practice of the ancient Romans. Other systems have been presented by Alberti, Palladio, Scamozzi, Serlio, Sir William Chambers, and others. But Vignola's Orders have generally been accepted as the standard. His works have been frequently republished, and recourse must be had to them for minute information in regard to details. But the dimensions given

in this book, and the methods of determining them here described, will suffice for the execution of all drawings and designs which are made to a small scale.

This volume is concerned only with Columns, Pilasters and Entablatures, Pediments, Pedestals and Balustrades. The employment of these Elements in the Composition of Doors and Windows, Wall Surfaces, external and internal, Staircases, Towers and Spires, Arches and Arcades, Vaults and Domes, and other architectural features, will, I hope, at a later day be made the subject of a separate treatise which will be the natural sequel to this one.

After the chief part of this volume was in press my attention was directed to a somewhat similar work by the celebrated James Gibbs, the architect of St. Martin's-in-the-Fields and of St. Mary-le-Strand. He published in London, in 1732, a series of plates showing the Orders and their applications with a brief descriptive text. The title page reads: "Rules for Drawing the several Parts of Architecture in a more Exact and Easy Manner than has been heretofore Practiced, by which all Fractions, in dividing the Principal Members and their Parts, are Avoided." The book begins with an *Address to the Reader* which opens as follows:

"Upon examination of the common ways of drawing the Five Orders of Architecture, I thought there might be a method found out so to divide the principal Members and their Parts, both as to their Heights and Projections, as to avoid Fractions. And having tried one Order with success, I proceeded to another, till at length I was satisfied it would answer my intention in all; and I doubt not but that the Method here proposed will be acknowledged by proper Judges to be the most exact, as well as the easiest, that hath as yet been published."

I find on examining the plates that, though they follow an entirely different system, they have anticipated some of the methods of the present work.

WILLIAM R. WARE.

October 1, 1902.

SCHOOL OF ARCHITECTURE, COLUMBIA UNIVERSITY.

1

# THE AMERICAN VIGNOLA

---

## THE FIVE ORDERS

---

### INTRODUCTION

1. A **building** is a shelter from rain, sun, and wind; this implies a *Roof*, and *Walls* to support it. If the walls entirely enclose the space within, there are *Doorways* for access, and *Windows* for light. Roofs and walls, doors and windows are the essential features of buildings.

2. **Roofs** may be flat, sloping, or curved. A roof with one slope is called a *Lean-To*, Fig. 1. When two sloping roofs rest upon parallel walls and lean against each other, they meet in a horizontal *Ridge*, Fig. 2, at the top, and form a *Gable* at each end. Roofs that rise from the same wall in

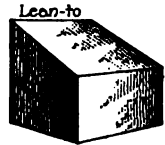

FIG. 1

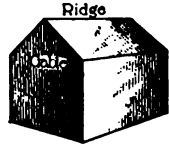

FIG. 2

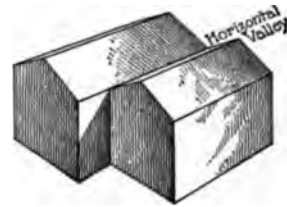

FIG. 3

opposite directions form a *Horizontal Valley*, Fig. 3, at the wall. If the walls make a projecting angle, the roofs intersect in an inclined line called a *Hip*, Fig. 4. If the walls meet in a reentering angle, the inclined line of intersection is called



a *Valley*. Circular walls carry conical, Fig. 5 (a), or domical roofs, Fig. 5 (b).

If there is more than one story, the flat roof of the lower story becomes the *Floor* of the story above. If the roof extends beyond the wall that supports it, the projection is



FIG. 4



FIG. 5 (a)



FIG. 5 (b)

called the *Eaves*, Fig. 6. If the wall also projects, to support the extension of the roof, the projection is called a *Cornice*, Fig. 7. The principal member of a cornice, which projects like a shelf, is called a *Corona*, Fig. 8.

**3.** Walls are generally made wider just at the bottom, so as to get a better bearing on the ground. This projection is the *Base*, Fig. 9. A similar projection at the top is called a *Cap*, or, if it projects much, a *Cornice*, as has been said. A low wall is called a *Parapet*. A short piece of wall about as long as it is thick is called a *Post*, and if it supports something, a *Pedestal*, Fig. 10; the part between its Cap and Base



FIG. 6



FIG. 7

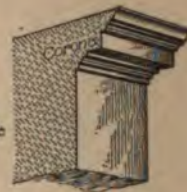

FIG. 8

is then the *Die*. A tall post is called a *Pier*, Fig. 11, if it is square, and a *Column* if it is round. Caps of piers and columns are called *Capitals*, and the part between the Cap and the Base, the *Shaft*. The flat upper member of a Capital is called the *Abacus*.

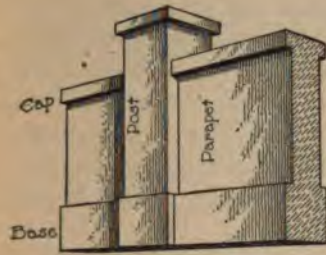

FIG. 9



FIG. 10

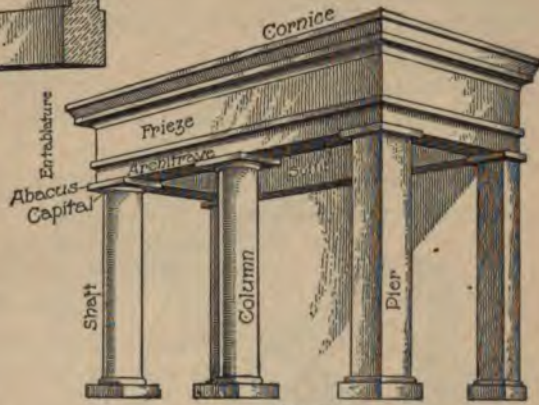

FIG. 11



Colonnade

FIG. 12



Arcade

FIG. 13

4. A beam that spans the space between two piers or columns, or between a pier or column and a wall, is called an *Architrave*, or *Epistyle*. Above it, between the Architrave and the Cornice, there is generally a little strip of wall called the *Frieze*. Architrave, Frieze, and Cornice constitute the *Entablature*. A series of columns is called a *Colonnade*, Fig. 12. The spaces between piers or columns are sometimes spanned by *Arches*, a series of which is called an *Arcade*, Fig. 13.

The space between two walls is sometimes covered by a sort of continuous arch, called a *Vault*, instead of by a floor or roof, Fig. 14.

The under surface of a beam or architrave is called its *Soffit*, and the same name is used also for the *Intrados*, or under surface of an arch or vault. The upper surface, or back of an arch, is called the *Extrados*, and the triangular space of wall above is called a *Spandrel*.

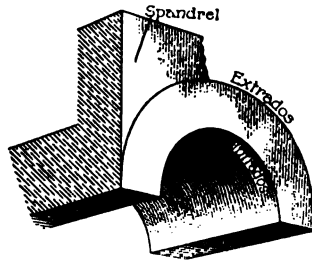

FIG. 14

The Wall, the Pier, and the Column, with or without a Pedestal, constitute the chief supporting members; the Frieze and Cornice, with the roof that rests upon them, constitute the chief part of the load they carry. The Architrave, the Arches, and the Spandrels form part of the load, relatively to what is below them, but are supporting members relatively to what is above them.

5. Besides being valuable as a shelter, a building may be in itself a noble and delightful object, and architects are builders who, by giving a building good proportions and fine details, and by employing beautiful materials, make it valuable on its own account, independently of its uses. Their chief instruments in this work are **Drawings**, both of the whole building and, on a larger scale, of the different features that compose it and of their details, which are often drawn full size. These drawings comprise *Plans*, *Sections*,

*Elevations, and Perspective Views, Fig. 15.* They serve to explain the intention of the architects to their clients and to their workmen.

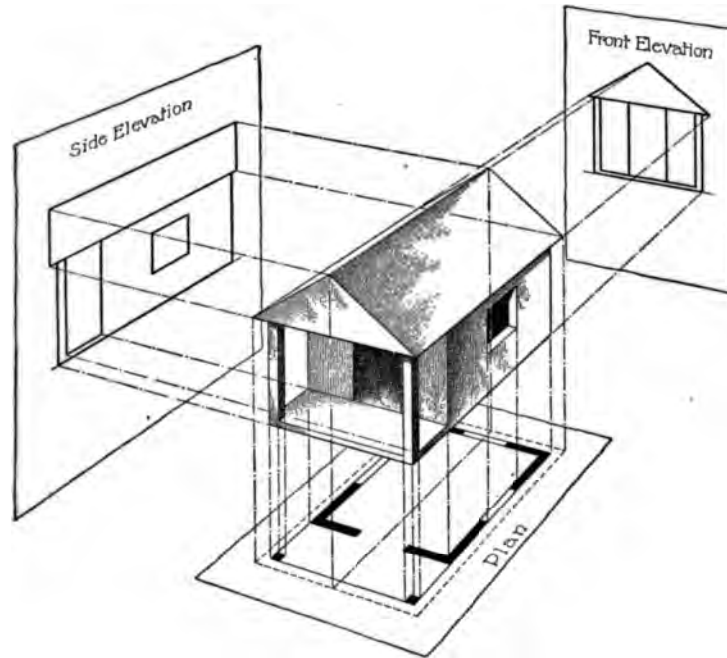

FIG. 15

### MOULDINGS—PLATE I

6. The simplest decorative details and those that are most universally used in buildings are called **Mouldings**.



FIG. 16



FIG. 17



FIG. 18

They are plane or cylindrical surfaces, convex, concave, or of double curvature, and they are sometimes plain and sometimes enriched by carving. They are called by various

technical names: Greek, Latin, Italian, French, and English. The cross-section of a moulding is called its *Profile*.

A small plane surface is called a *Band*, *Face*, or *Fascia*, Fig. 16, and if very small a *Fillet*, *Raised* or *Sunk*, Fig. 17, *Horizontal*, *Vertical*, or *Inclined*.

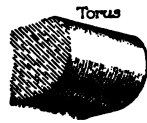

FIG. 19

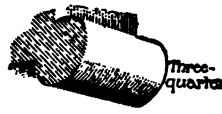

FIG. 20



FIG. 21

A convex moulding is called an *Ovolo*, Fig. 18, *Torus*, Fig. 19, or *Three-Quarter Moulding*, Fig. 20, according to the amount of the curvature of its profile. A small Torus is called a *Bead*, Fig. 21, *Astragal*, or *Reed*, and an elliptical one, a *Thumb Moulding*, Fig. 22. Concave mouldings are, in like manner,



FIG. 22

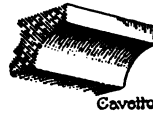

FIG. 23

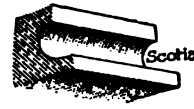

FIG. 24

called *Cavetto*, Fig. 23, *Scotia*, Fig. 24, or *Three-Quarter Hollow*, but the term *Scotia* (darkness) is often used for any hollow moulding. A Cavetto tangent to a plane surface is called a *Congé*, Fig. 25.

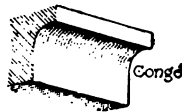

FIG. 25



FIG. 26 (a)

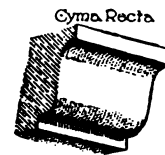
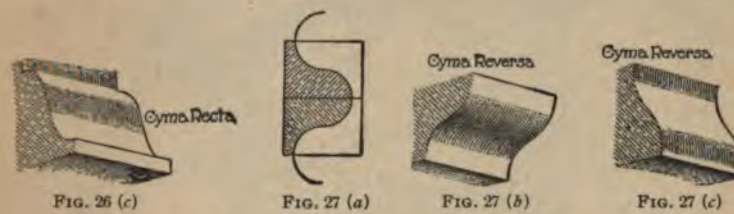

FIG. 26 (b)

A moulding with double curvature is called a *Cyma*, or *Wave Moulding*. If the tangents to the curve at top and bottom are horizontal, as if the profile were cut from a horizontal wavy line, it is called a *Cyma Recta*, Fig. 26; if vertical, as if cut from a vertical line, a *Cyma Reversa*, Fig. 27. The *Cyma Recta* is sometimes called *Cyma Reversa*, Fig. 26 (c), when

it is turned upside down. But this leads to confusion. The Cymas vary also, Fig. 28, in the shape and relative size of their concave and convex elements. A small Cyma is called a *Cymatium*. A small moulding placed above a Band, or any larger moulding, as a decoration, is also called a *Cymatium*, Fig. 29, whatever its shape.



When a convex and a concave moulding, instead of being tangent, come together at an angle, they constitute a *Beak Moulding*, Fig. 30.

Some architectural features, such as Bases, Caps, and Balusters, consist entirely of mouldings. Others consist mainly of plane surfaces, mouldings being employed to mark the boundary between different features, as between the Architrave and Frieze, or between different members of the same feature, as



between the Shaft of a column and its Capital, Fig. 31. In these cases the mouldings, since they occur on the edges of the stone blocks, indicate, while they conceal, the position of the joints of the masonry. Mouldings are often placed also in the internal angle where two plane surfaces meet, as is the case between the Frieze and the Corona of the Cornice, and under the Abacus of the Capital. When placed upon the external angle formed by two planes, they are, in the Gothic

Styles, Fig. 32, often cut in, so as to lie down below the surface of both planes; but in the Classical Styles, they pro-

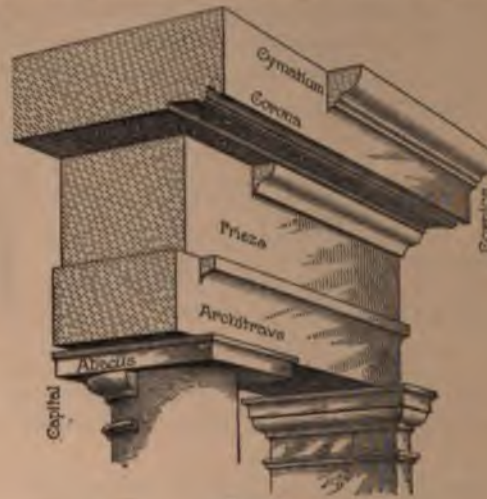

FIG. 31

ject beyond the plane of one of the surfaces, like a little cornice, as is often seen in the Abacus of a Capital.

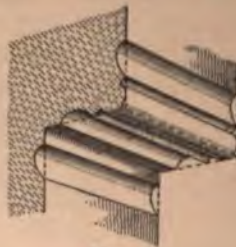

FIG. 32



FIG. 33

Horizontal Mouldings, separating plane surfaces, are called a *String Course*, Fig. 33.

#### TABLE OF MOULDINGS, PLATE I

*Plane*.—Face, Band, or Fascia; Beveled, Inclined, or Splay Face; Fillet, vertical, horizontal, or beveled, Raised or Sunk.







*Convex*.—Ovolo, or Quarter Round; Torus, or Half Round; Thumb Moulding, or Elliptical Torus; Three-Quarter Round; Bead, Astragal, or Reed; Three-Quarter Bead.

*Concave*.—Cavetto, or Quarter Hollow; Congé; Half Hollow; Scotia; Three-Quarter Hollow.

*Double Curvature*.—Cyma Recta; Cyma Reversa; Cymatium; Beak Moulding.

Besides the differences of size and shape already mentioned, and indicated in the table, mouldings of the same name differ in the kind of curve they employ. They may be arcs either of circles, ellipses, parabolas, or hyperbolas, or of any other curve.

**7. Styles.**—Different systems of construction have prevailed among different races, some employing only the Beam and Column, some also the Arch and Vault. In the choice of mouldings, also, some have adopted one set of forms, some another. The forms employed by the Greeks and Romans constitute what are called the Classical Styles; those used in the Middle Ages, the Byzantine, Romanesque, and Gothic Styles. Some of the Gothic mouldings have special names, such as Boltel, Scroll, etc.

At the close of the Middle Ages, about 400 years ago, the Classical styles were revived, as the Medieval styles have been during the last hundred years. Both are now in use. The styles of Egypt, India, and China are employed only occasionally and as a matter of curiosity.

---

#### THE ORDERS

**8.** In the Classical styles, several varieties of Column and Entablature are used; these are called the **Orders**. Each order, Fig. 34, comprises a Column with Base, Shaft, and Capital, with or without a Pedestal, with its Base, Die, and Cap, and is crowned by an Entablature, consisting of Architrave, Frieze, and Cornice. The Entablature is generally about one-fourth as high as the Column, and the Pedestal one-third more or less.

The principal member of the Cornice is the Corona, Fig. 35. Above the Corona, the Cornice is regularly terminated by a member originally designed to serve as a gutter to receive the water running down the roof. It generally consists of a large Cyma Recta, though the Ovolo and the Cavetto are often used. It is called the *Cymatium*, in spite of its large size, and whatever its shape.

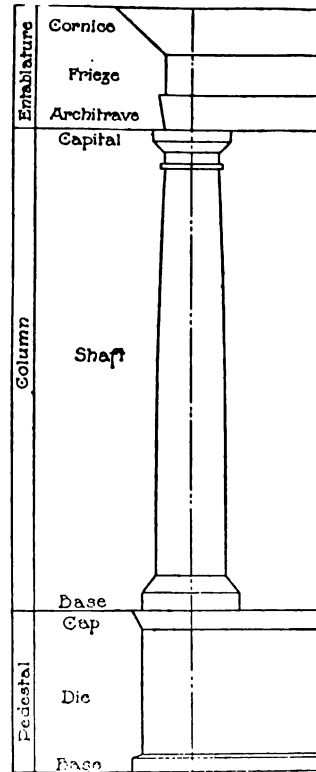

FIG. 34

NOTE.—The word *Cymatium* thus has three meanings: (1) A small Cyma; (2) a small crowning member, of whatever shape, though it is most frequently a Cyma Reversa; (3) the upper member of a Cornice, occupying the place of a gutter, whatever its shape, though it is generally a large Cyma Recta. In Classical Architecture, the Cyma Recta seldom occurs, except at the top of the Cornice and at the bottom of the Pedestal.

It would seem as if a cornice that occurs at the top of a wall and carries the edge of a roof would properly have a Cymatium, this being the place for a gutter, and that Cornices used as String Courses, half way up a wall, would

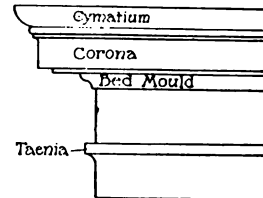

FIG. 35

naturally be without this member. But the significance of the *Cymatium* has frequently been overlooked, in ancient times and in modern. Many Greek temples have a *Cymatium* on the sloping lines of the gable, where a gutter would be useless, Fig. 120, and none along the Eaves, and in many modern buildings the cornices are crowned by large *Cymatia* in places where there are no roofs behind them.

The Corona is supported by a Moulding or group of Mouldings, called the *Bed Mould*. A row of brackets, termed *Blocks*, Fig. 36, *Modillions*, or *Mutules*, Fig. 37, according to their shape, resting on the *Bed Mould* and supporting the soffit of

the Corona, is often added. At the top of the Architrave is a projecting moulding that, when square, is called a *Tenia*, and the face of the Architrave is often broken up into two or three Bands or Fascias, Fig. 38.

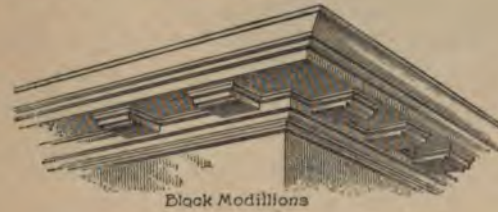

FIG. 36

The Abacus of the Capital also has a sort of bed mould beneath it, which, when convex, is called an *Echinus*, Fig. 39, from the sea shell, Fig. 40, which it resembles in shape.

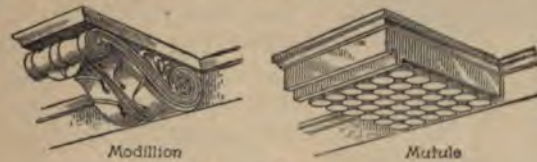

FIG. 37

The little Frieze below it is called the *Necking*. But if the bed mould under the Abacus is concave, it dies into the necking like a large Congé, and the two together constitute the



FIG. 38

*Bell* of the Capital, Fig. 41. The Abacus is square in plan, but the Echinus, or the Bell below it, is round, like the column.

At the top of the shaft is a member called the *Astragal*, consisting of a Bead, Fillet, and Congé. It has a flat surface

on top, as wide as the projection of the Congé, Fig. 42. At the bottom of the shaft is another Congé, below which is a broad fillet called the *Cincture*, Fig. 43. The Base generally

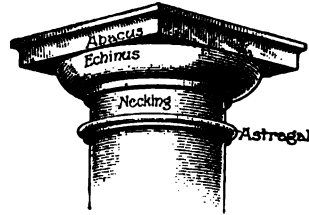

FIG. 39



FIG. 40

has, below the base mouldings, a plain member called the *Plinth*, which is square in plan like the Abacus.

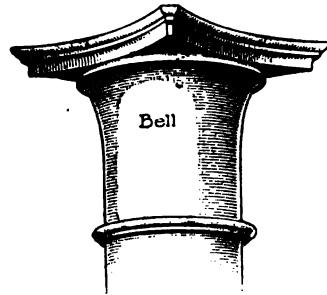

FIG. 41

The Shaft diminishes as it rises, Fig. 44, the upper diameter being only five-sixths of the lower, and the outline is not straight, but curved. This curve, which is called the *Entasis*, or bending, as of a bow, generally begins one-third of the way up, the lower third being cylindrical. The Entasis is not to be confounded with the *Diminution*, which is generally one-sixth, the upper diameter being five-sixths of the lower.

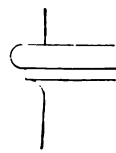

FIG. 42

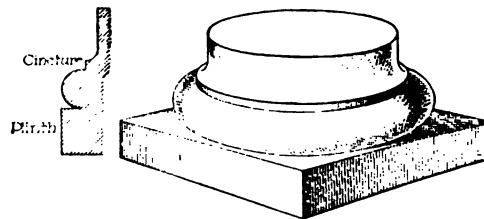

FIG. 43

Generally, the Pedestal also has a Corona and Bed Mould, but no gutter, above the Die, and a Base Moulding and Plinth below it.

9. In the choice and use of mouldings, the tastes and fashions of the Greeks and Romans were quite contrary to those of their successors in the Middle Ages. The Ancients preferred to use vertical and horizontal surfaces at right angles to each other, and seldom used an oblique line, or an acute or obtuse angle, as the Gothic architects did. They also preferred the *Cyma Reversa*, seldom employing the *Cyma Recta*, which in the Middle Ages was rather the favorite. Moreover, as has been said, the Gothic architects, in decorating a corner or edge, often cut it away to get a moulding, but the Ancients raised the moulding above the plane of the surface to which it was applied. In the composition and sequence of mouldings also, the Classical architects generally avoided repetition, alternating large and small, plain and curved, convex and concave. The convex and concave profiles seldom describe an arc of more than 180 degrees, and except in the case of the *Beak Moulding* and of the *Bead*, mouldings are always separated by *Fillets*. When a moulding is enriched, it is generally by carving ornamental forms, Fig. 45, upon it that resemble its own profile. The Greeks frequently employed elliptical and hyperbolic profiles, while the Romans generally used arcs of circles.

Among the Greeks, the forms, Fig. 46, used by the Doric race, which inhabited Greece itself and had colonies in Sicily and Italy, were much unlike those of the Ionic race, which inhabited the western coast of Asia Minor, and whose art was greatly influenced by that of Assyria and Persia. The Romans modified the *Ionic* and *Doric* styles, Fig. 47, and also devised a third, which was much more elaborate than either of them, and employed brackets, called *Modillions*, in the *Cornice*. This they called the *Corinthian*, Fig. 48. They used also a simpler Doric called the *Tuscan*, Fig. 49, and a cross between the *Corinthian* and *Ionic* called the *Composite*, Fig. 50. These are the *Five Orders*. The ancient examples

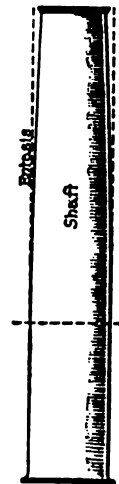

FIG. 44

vary much among themselves and differ in different places, and in modern times still further varieties are found in Italy, Spain, France, Germany, and England.

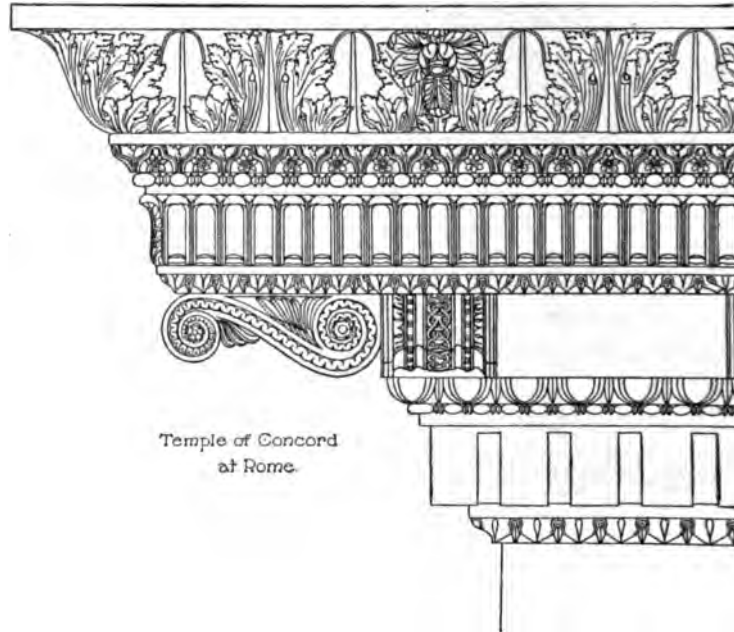

FIG. 45

The best known and most admired forms for the Orders are those worked out by Giacomo Barozzi da Vignola, in the 16th century, from the study of ancient examples. The Orders that are shown in the large plates almost exactly follow Vignola's rules.

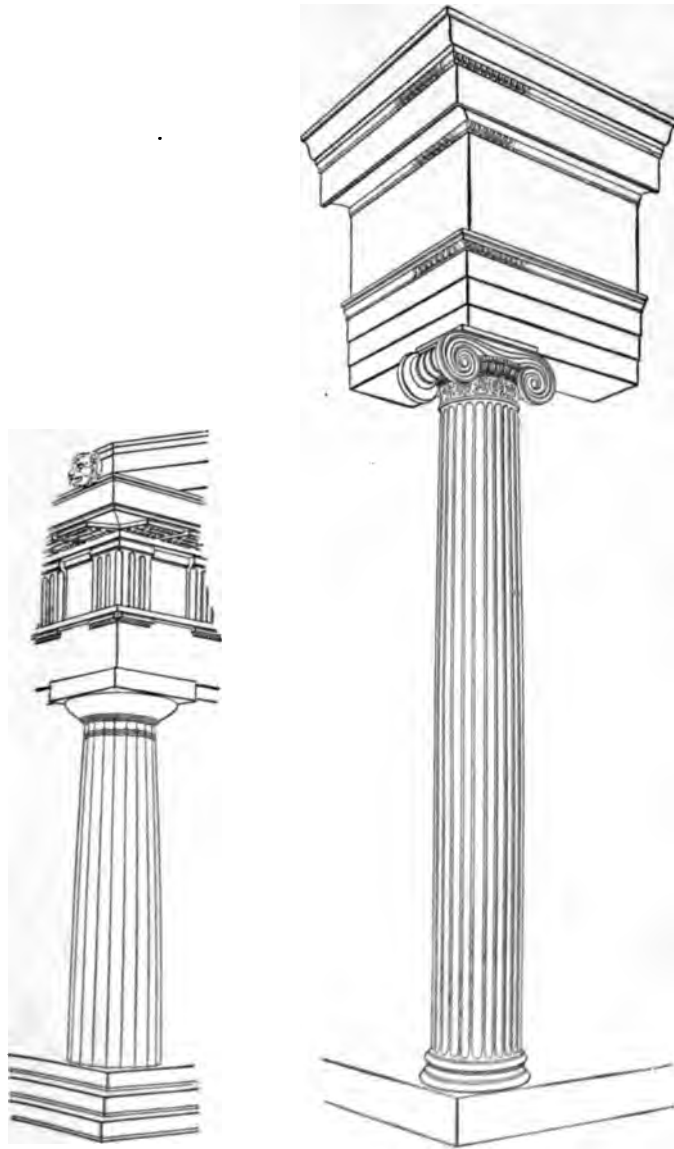
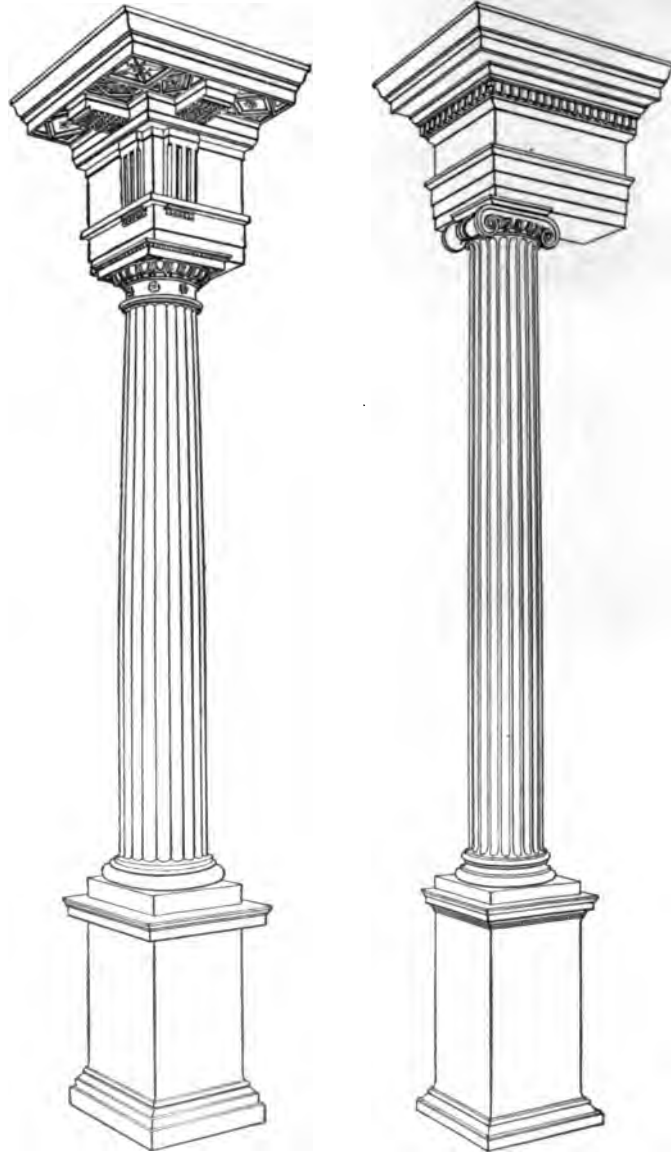

FIG. 46





Doric

Ionic

FIG. 47

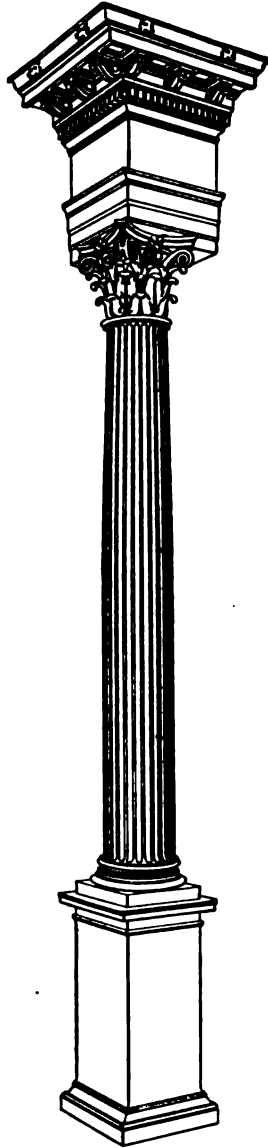

Corinthian  
FIG. 48

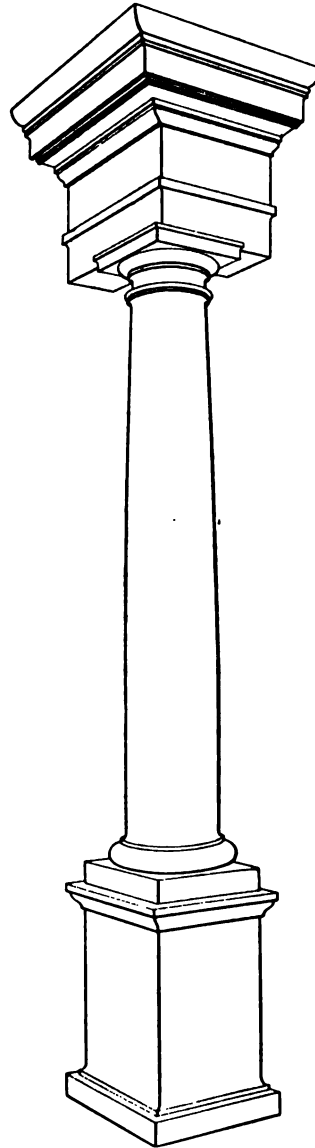

Tuscan  
FIG. 49

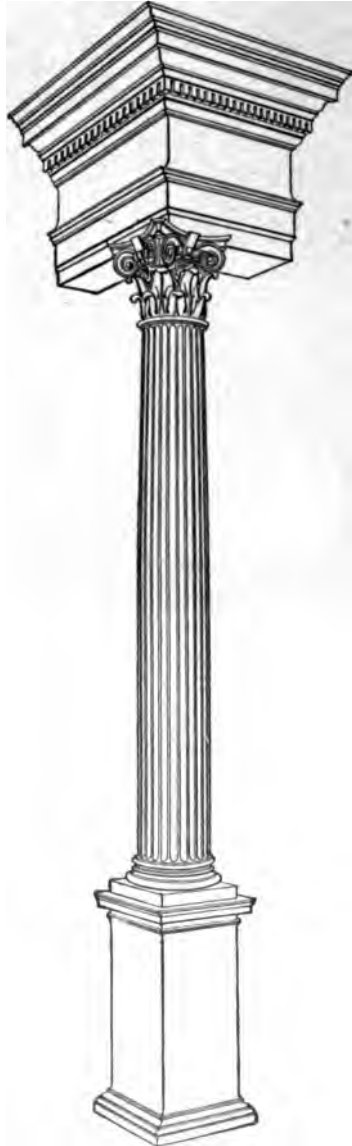

Composite

FIG. 50

Handwritten scribbles or marks in the center of the page.

# COMPARISON

TYPE OF ORDER	NAMES OF FEATURES		GREEK DORIC	TU	
	ENTABLATURE 1/4 to 1/5	CORNICE <small>GMATIUM CORONA BED MOULD</small>	2	1/2	
		FRIEZE		3/4	
		ARCHITRAVE <small>TÆNIA</small>		3/4	
	COLUMN 1	CAPITAL <small>ABACUS ECHINUS NECKING ASTRAGAL</small>	4-6	1/2	7
		SHAFT			
		BASE <small>CINCTURE BASE MOULD PLINTH</small>		NONE	
		PEDESTAL 1/3 ±		NO PEDESTAL BUT THREE STEPS THE STYLOBATE	
	DIE <small>CORONA BED MOULDING</small>				
	BASE <small>BASE MOULD PLINTH</small>				

# THE ORDERS

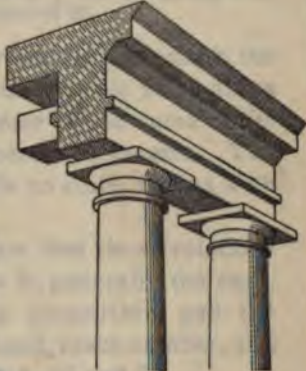
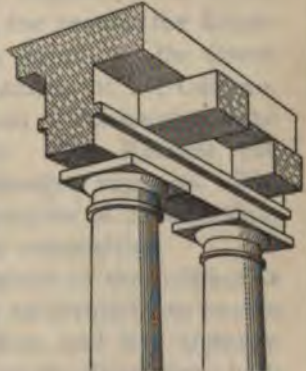
DORIC		IONIC		CORINTHIAN COMPOSITE		PERSPECTIVE VIEW		
2	3/4	2 1/4	7/8	2 1/2	1		 <p>FROM WITHOUT</p>	
	3/4		6/8		3/4			
	1/2		5/8		3/4			
8	1/2	9	1/3 <small>(1/2)</small>	10	7/6	 <p>FROM WITHIN</p>		
	7		8		8 1/3			
	1/2		1/2		1/2			
ONE NINTH THE HEIGHT OF THE PEDESTAL								
PEDESTAL 1/3 [VIGNOLA]								
TWO NINTHS THE HEIGHT OF THE PEDESTAL								

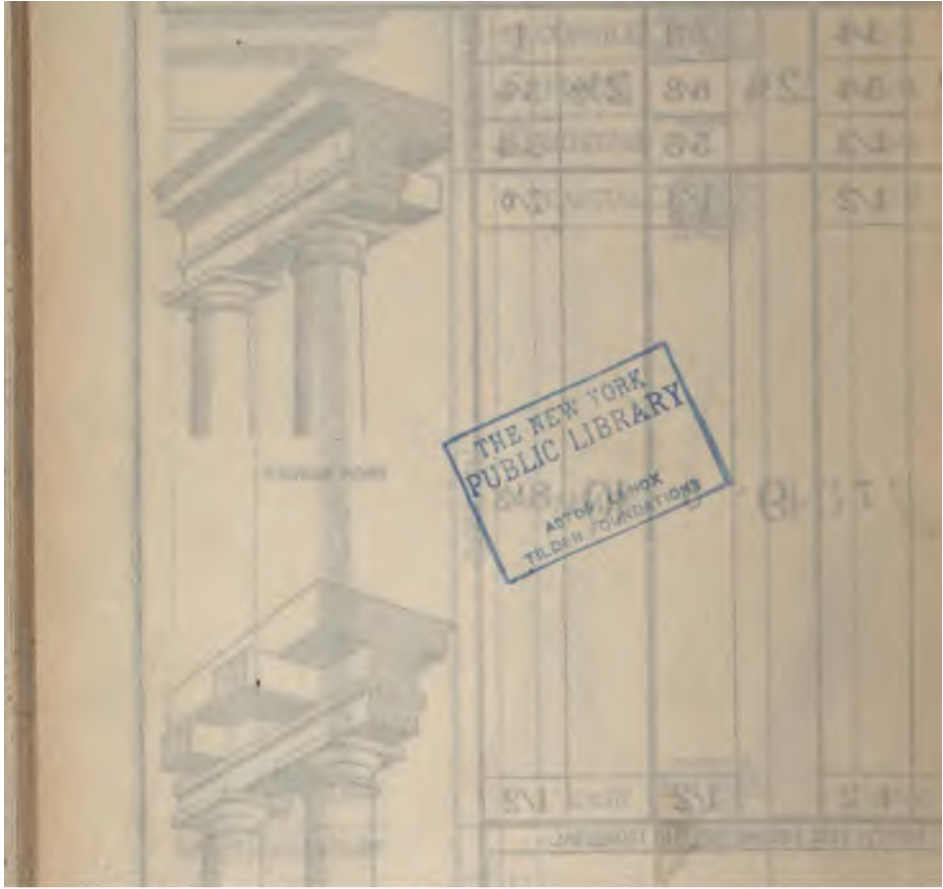

## VIGNOLA'S ORDERS—PLATE II

10. *Plate II* shows the proportions of the Orders according to Vignola, in terms of the lower diameter of the columns. These vary in height from seven Diameters to ten.

NOTE.—It is worth noting that, in ordinary handwriting, the T, for Tuscan, looks like a 7; D, for Doric, like an 8; I, for Ionic, like a 9; Co, for Corinthian and Composite reminds one of 10.

The Entablature is in all of them ordinarily one-fourth the height of the column, but it is sometimes made as small as one-fifth. The projection of the Cornice is the same as its height, except in the Doric Order, where it is greater. The lower band of the Architrave is made to come in line with the upper face of the shaft.

But it is only when seen in elevation that these relations obtain. When seen in perspective, as is generally the case, the cornice appears much larger, in proportion, and the frieze and architrave, being foreshortened, much smaller, and the architrave overhangs the shaft, Figs. 53 and 57.

In the Greek Orders, the Column is from five to ten Diameters in height and the Entablature always about two Diameters. In the Greek Orders, accordingly, the taller the Column, the lighter the Entablature, relatively; but in the Roman Orders, the taller the Column, the heavier the Entablature, actually. It follows that the weight of the Greek Entablature is proportioned to the diameter of the Column, irrespective of its height; of the Roman to the height of the Column, regardless of its diameter. The Romans put the least weight on the shortest and strongest supports. The Greek plan shows more regard to principles of construction, the Roman to principles of decorative composition.

Vignola used half of the lower diameter of the Column as his unit of measure, or *Module*. This he divided into twelve Parts for the Tuscan and Doric Orders, and into eighteen Minutes for the others, and he gives all the dimensions both of the larger members and of the mouldings in terms of Modules and Parts, or Minutes, sometimes using even the quarter Minute, or one one-hundred-and-forty-fourth of a



Diameter. But it is equally practicable and more convenient to use the whole Diameter as a unit of measure, dividing it only into Fourths and Sixths, and occasionally using an Eighth or a Twelfth.

In Plates IV, VI, VII, IX, XI, and XIII, the first column on the left shows the vertical dimensions as given in Plate II.

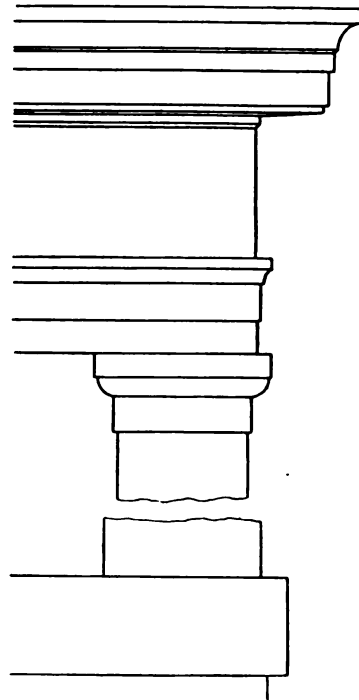

Temple of Pnyx

FIG. 51

In the second column, these divisions are subdivided into equal parts, the third column giving a further division of the dimensions thus obtained. Most of these dimensions can be stated in terms of sixths or fourths of the Diameter, as appears in the Tables. This analysis does not reach the smaller details, the shape and size of which must be learned by observation. Indeed, all these forms should be made so familiar that they can be drawn accurately from memory, these arithmetical relations being used only to test the accuracy of the result, or to discover how much the proportions adopted in any given case differ from the regular type. For Vignola's Orders are to be regarded

only as an admirable standard that may be safely adopted when there is no occasion to do anything else, but which is to be departed from and varied whenever there is any reason for doing so. Vignola obviously so regarded them. He did not himself adhere closely to his own rules, or generally adopt his Orders in his own work. His Doric and Ionic are to be found, however, in the Villa Caprarola.



THE NEW YORK  
PUBLIC LIBRARY

ASTOR, LENOX  
AND TILDEN  
FOUNDATIONS

SECTION OF COLUMN AND BASE

SECTION OF COLUMN AND BASE

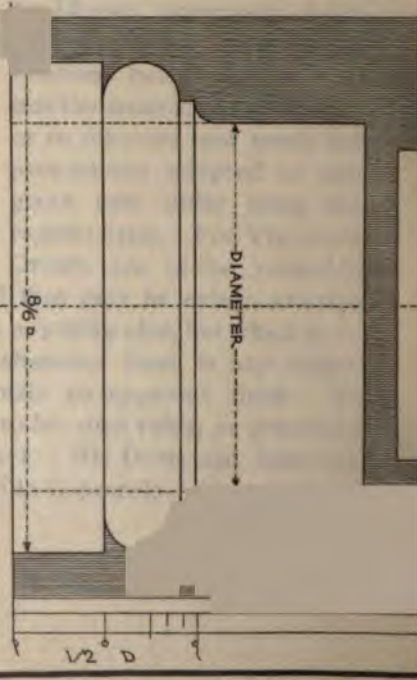
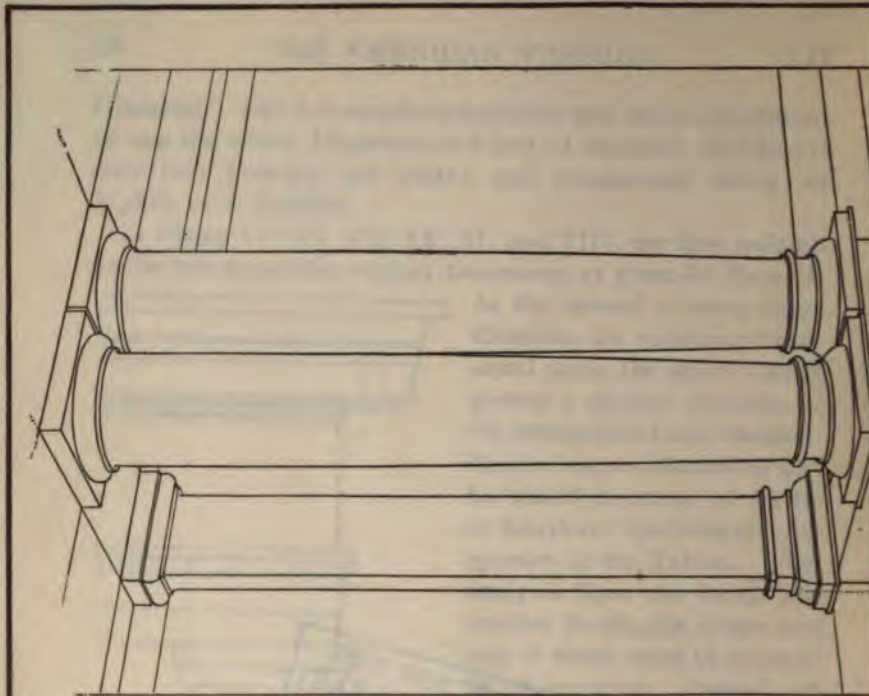

ELEVATION OF CAPITAL AND BASE

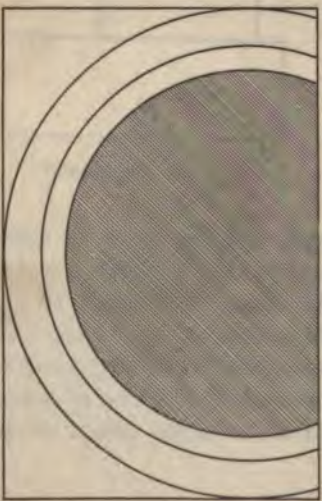

PLAN OF BASE

# TUSCAN ORDER

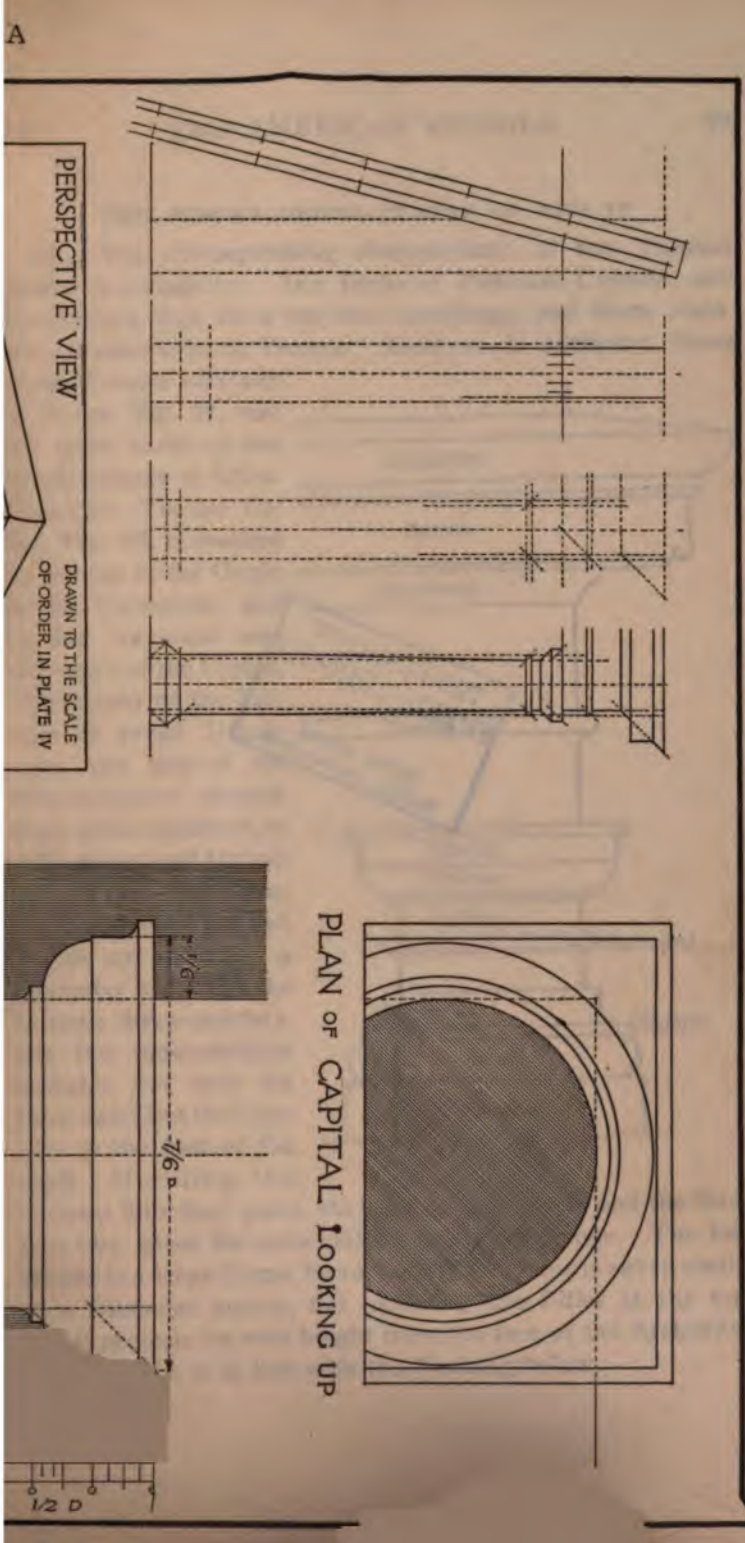

A

TUSCAN ORDER

THE NEW YORK  
PUBLIC LIBRARY  
ASTOR LENOX  
TILDEN FOUNDATIONS



PLATE 10



## THE TUSCAN ORDER—PLATES III AND IV

11. The distinguishing characteristic of the **Tuscan Order** is simplicity. Any forms of Pedestal, Column, and Entablature that show but few mouldings, and those plain, are considered to be Tuscan. Such are, in antiquity, those of the Temple of Piety in Rome, Fig. 51, and the lower order of the Amphitheater at Arles. Vignola's Tuscan Order, Fig. 52, is marked by the use of the Ovolo in the Cymatium, and by the frequent employment of the Congé. The height of the Column is seven Diameters and that of the Entablature accordingly seven-quarters, or a Diameter and three-quarters. The Base, Capital, Architrave, and Frieze are each half a Diameter high, and the Cornice three-quarters. But this measurement includes not only the Base itself, but the Cincture at the foot of the shaft. Dividing the

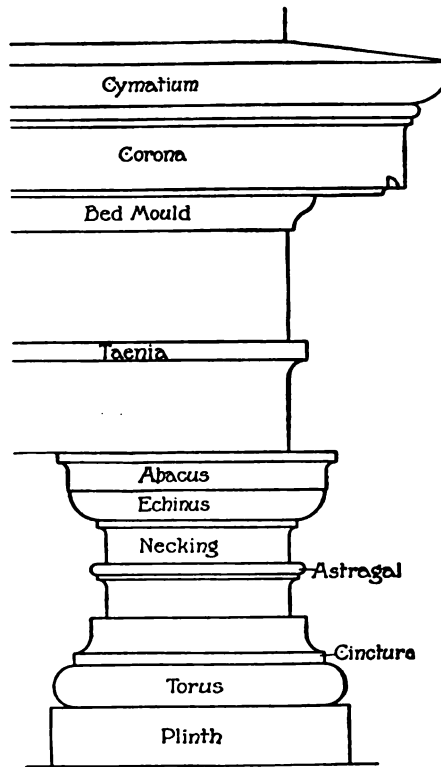

FIG. 52

Cornice into four parts, the Capital into three, and the Base into two, gives the principal horizontal divisions. The Bed Mould is a large Cyma Reversa. The Abacus is seven-sixths of a Diameter across, not including the Fillet at the top, and it projects its own height from the face of the Architrave above, which is in line with the Necking below.

All the principal dimensions can be expressed in terms of fourths and sixths of the lower Diameter of the Shaft.

Vignola makes the width of the Plinth a little greater than this, and sets the Bed Mould up one-twelfth, making the Frieze wider and the Corona narrower.

TABLE OF THE TUSCAN ORDER—PLATES V, VI, AND VII

$\frac{1}{4} D$	equals	height of Plinth.					
$\frac{2}{3} D$	equals	<table style="border-collapse: collapse; margin: 0;"> <tr> <td style="border-right: 1px solid black; padding-right: 5px;">height of Cornice.</td> <td rowspan="2" style="font-size: 2em; padding: 0 5px;">}</td> </tr> <tr> <td style="border-right: 1px solid black; padding-right: 5px;">projection of Cornice.</td> </tr> </table>	height of Cornice.	}	projection of Cornice.		
height of Cornice.	}						
projection of Cornice.							
$\frac{1}{3} D$	equals	<table style="border-collapse: collapse; margin: 0;"> <tr> <td style="border-right: 1px solid black; padding-right: 5px;">height of Necking.</td> <td rowspan="3" style="font-size: 2em; padding: 0 5px;">}</td> </tr> <tr> <td style="border-right: 1px solid black; padding-right: 5px;">height of Echinus.</td> </tr> <tr> <td style="border-right: 1px solid black; padding-right: 5px;">height of Abacus.</td> </tr> </table>	height of Necking.	}	height of Echinus.	height of Abacus.	
height of Necking.	}						
height of Echinus.							
height of Abacus.							
$\frac{1}{2} D = \frac{2}{3} D$	equals	<table style="border-collapse: collapse; margin: 0;"> <tr> <td style="border-right: 1px solid black; padding-right: 5px;">height of Base, including Cincture.</td> <td rowspan="4" style="font-size: 2em; padding: 0 5px;">}</td> </tr> <tr> <td style="border-right: 1px solid black; padding-right: 5px;">height of Capital.</td> </tr> <tr> <td style="border-right: 1px solid black; padding-right: 5px;">height of Architrave.</td> </tr> <tr> <td style="border-right: 1px solid black; padding-right: 5px;">height of Frieze.</td> </tr> </table>	height of Base, including Cincture.	}	height of Capital.	height of Architrave.	height of Frieze.
height of Base, including Cincture.	}						
height of Capital.							
height of Architrave.							
height of Frieze.							
$\frac{5}{8} D$	equals	upper Diameter of Shaft.					
$\frac{6}{8} D$	equals	lower Diameter of Shaft.					
$\frac{7}{8} D$	equals	width of Abacus.					
$\frac{8}{8} D$	equals	width of Plinth.					
$\frac{1}{12} D$	equals	width of Tænia.					
$\frac{1}{8} D$	equals	<table style="border-collapse: collapse; margin: 0;"> <tr> <td style="border-right: 1px solid black; padding-right: 5px;">height of Astragal.</td> <td rowspan="2" style="font-size: 2em; padding: 0 5px;">}</td> </tr> <tr> <td style="border-right: 1px solid black; padding-right: 5px;">projection of Astragal.</td> </tr> </table>	height of Astragal.	}	projection of Astragal.		
height of Astragal.	}						
projection of Astragal.							

THE DORIC ORDER—PLATES VII, VIII, IX, AND X.

12. The distinguishing characteristics of the **Doric Order**, Figs. 53 and 54, are features in the Frieze and in the Bed Mould above it, called *Triglyphs* and *Mutules*, which are supposed to be derived from the ends of beams and rafters in a primitive wooden construction with large beams. Under each Triglyph, and beneath the Tænia that crowns the Architrave, is a little Fillet called the *Regula*. Under the

1950



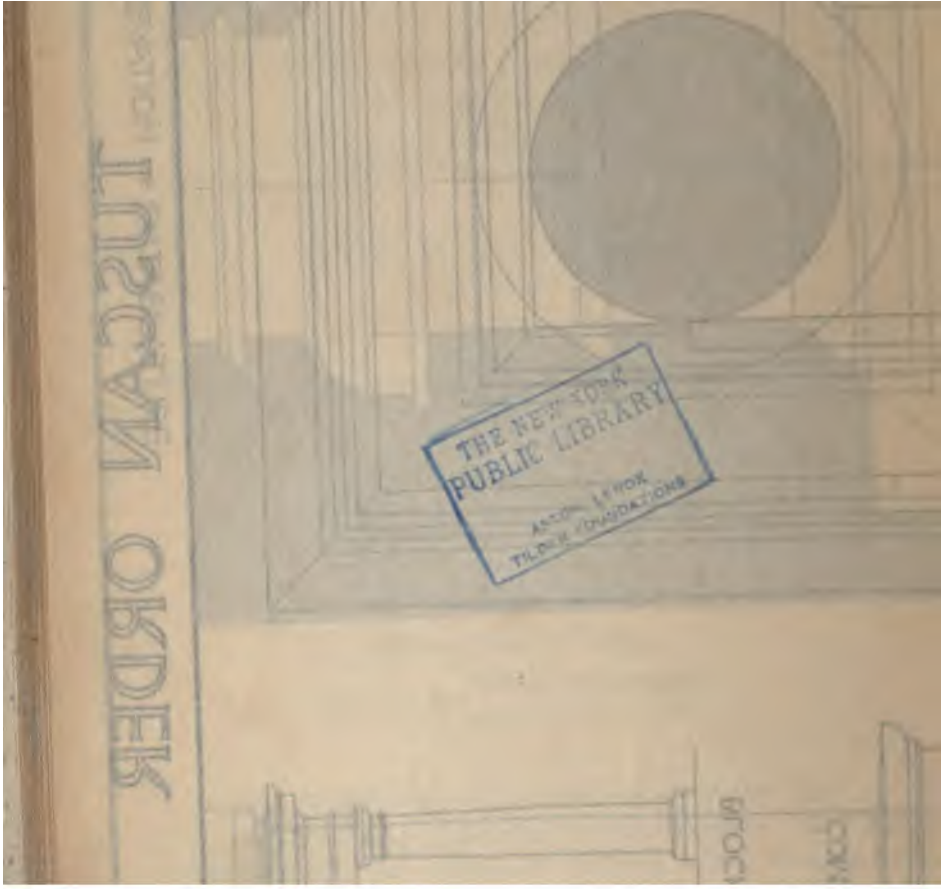

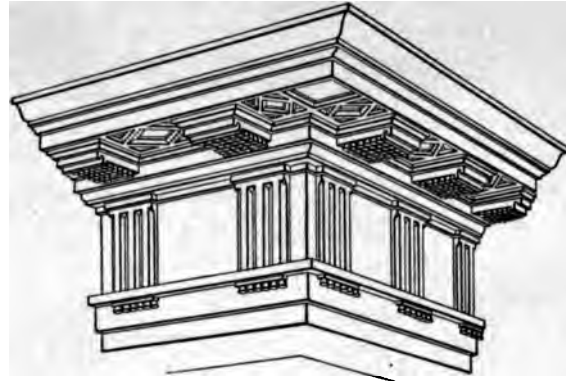

FIG. 53

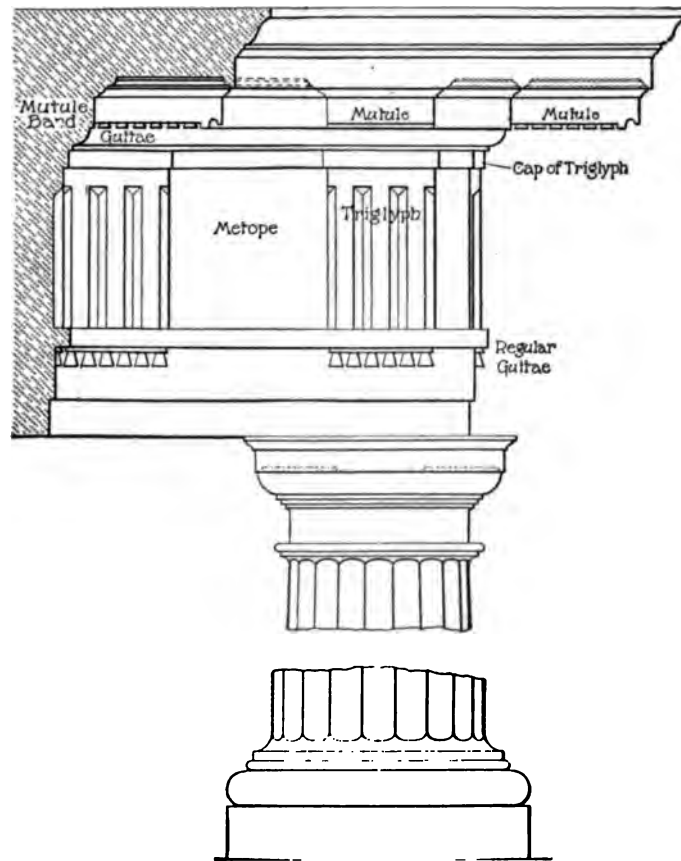
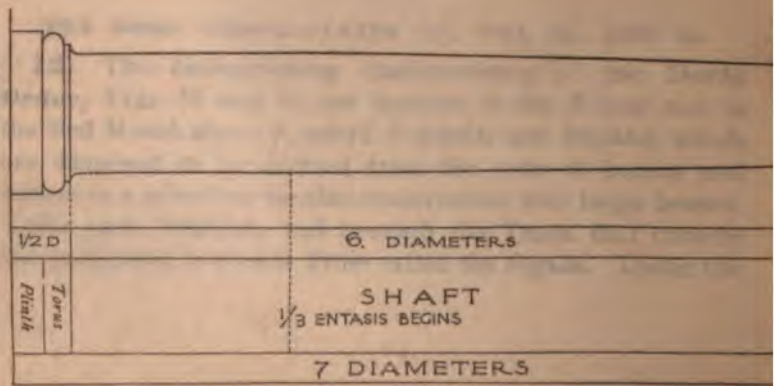
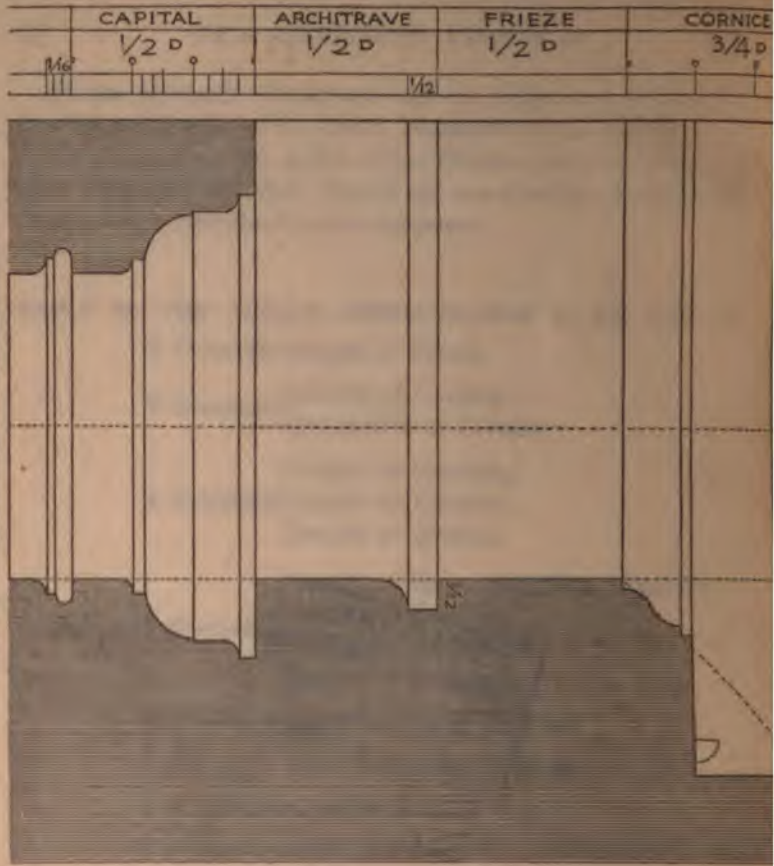
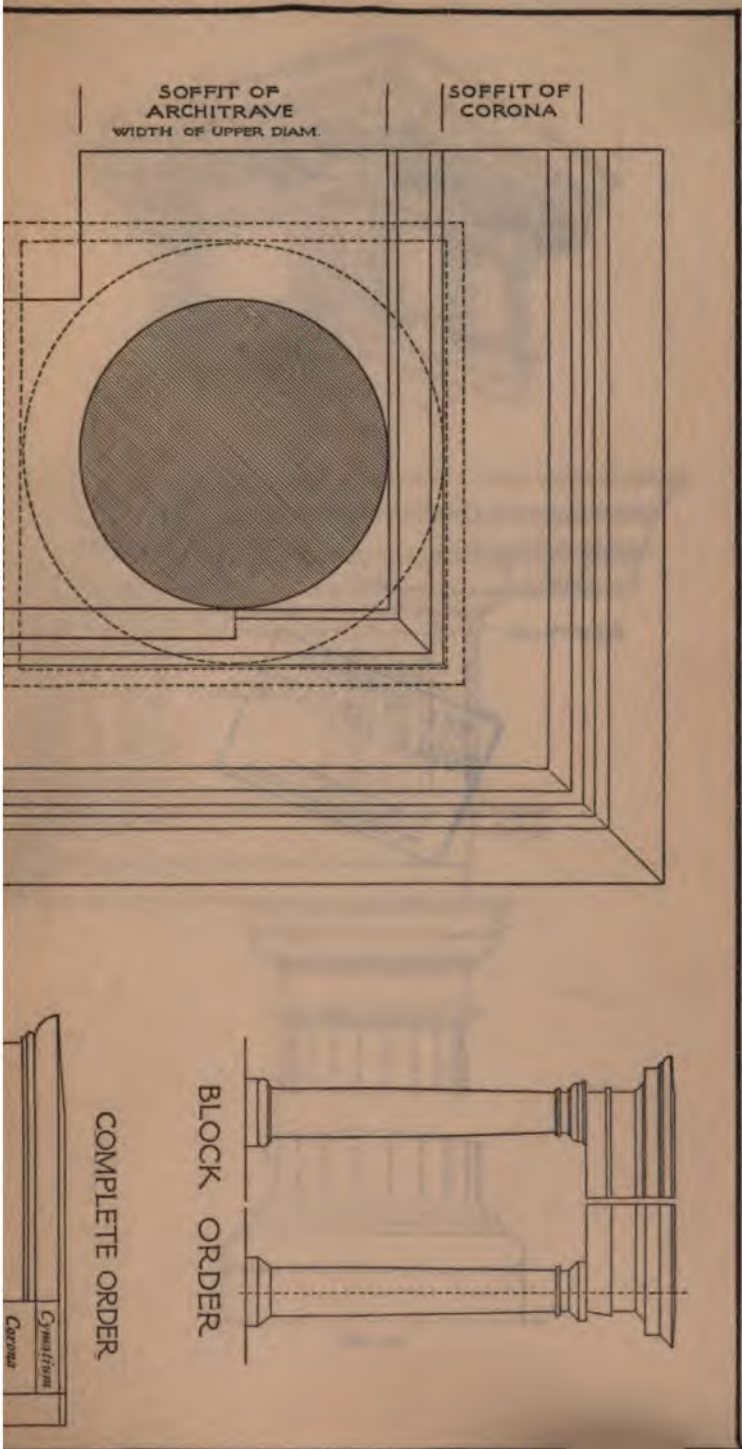

FIG. 54

ELEVATION of ENTABLATURE



# TUSCAN ORDER



INSCANI ORDER

THE NEW YORK  
PUBLIC LIBRARY  
ASTOR LENOX  
TILDEN FOUNDATIONS

BLOCH

COM

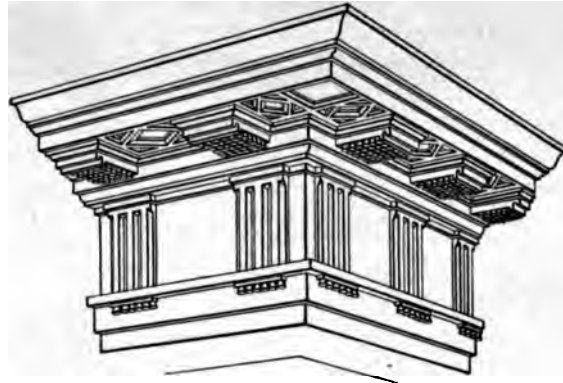

FIG. 53

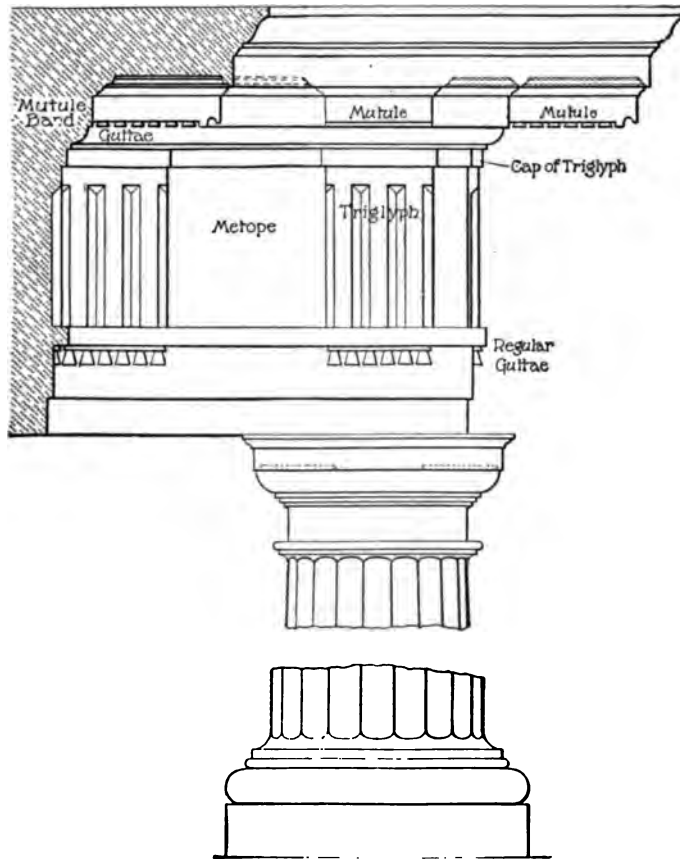
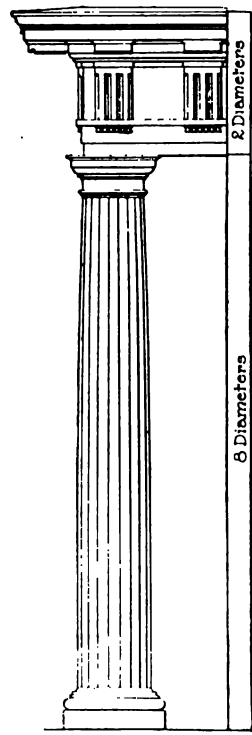

FIG. 54

Regulae are six long drops, called *Guttæ*, which are sometimes conical, sometimes pyramidal. There are also either eighteen or thirty-six short cylindrical *Guttæ* under the soffit of each *Mutule*. The *Guttæ* are supposed to represent the heads of wooden pins, or treenails.



Mutular Doric

FIG. 55

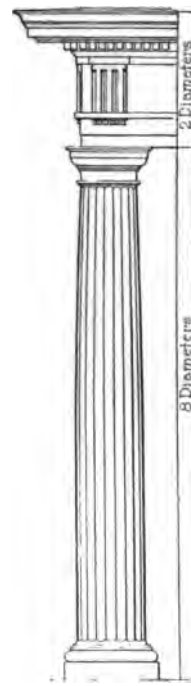

Denticulated Doric

FIG. 56

Two different Doric Orders are in use, the *Mutular*, Figs. 53, 54, and 55, and the *Denticulated*, Figs. 56, 57, and 58. They differ chiefly in the cornices. In both of them the height, of three-quarters of a Diameter, is divided into four equal parts, the upper one embracing the gutter, or Cymatium, and the Fillet below, the next the Corona and the small Cyma Reversa, or Cymatium, above it. But the Bed Moulds

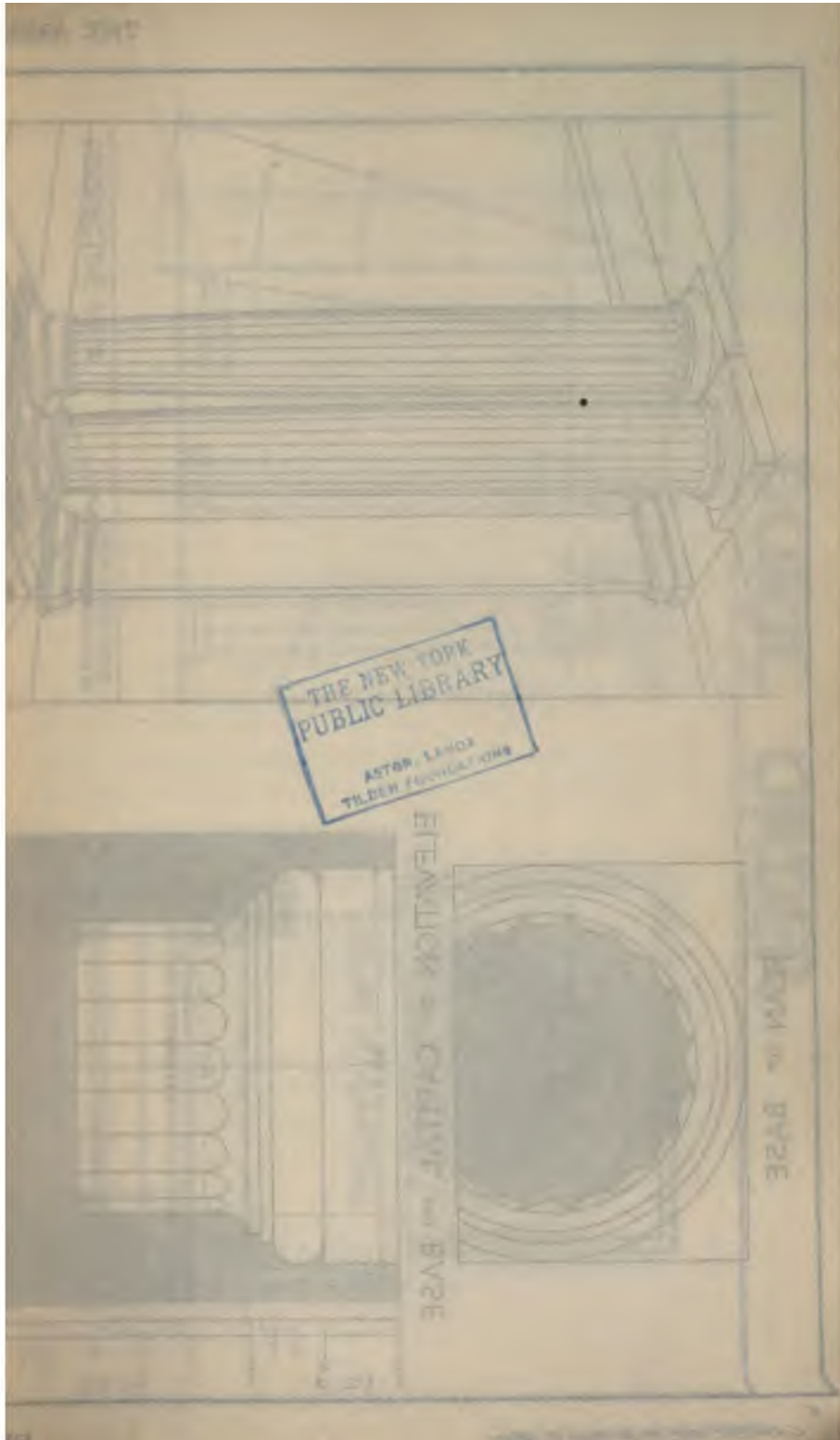

THE NEW YORK  
PUBLIC LIBRARY  
ASTOR, LENOX  
TILDEN FOUNDATION

ELEVATION & CAPITAL OF THE BASE

VIEW OF THE BASE



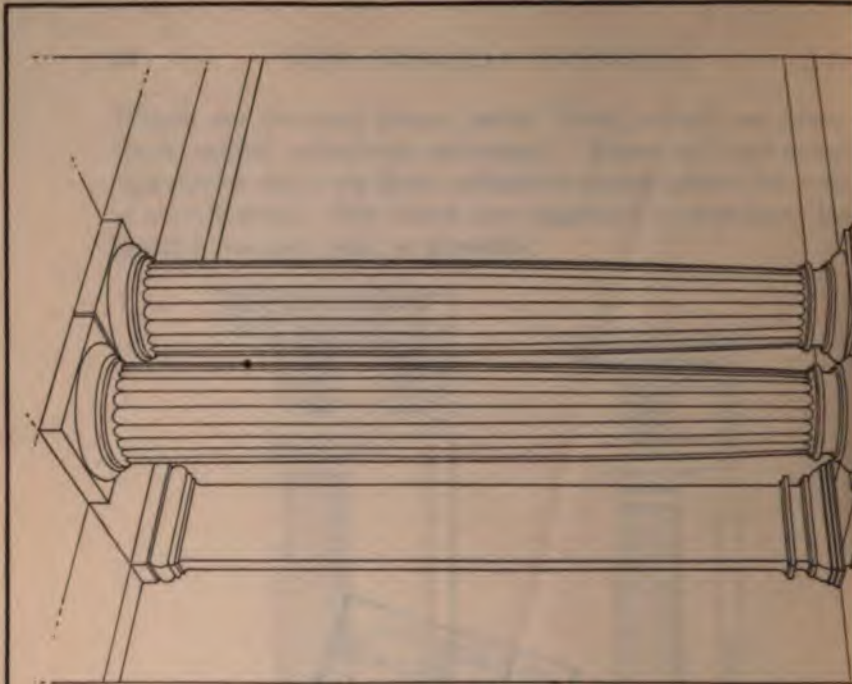

ELEVATION OF CAPITAL AND BASE

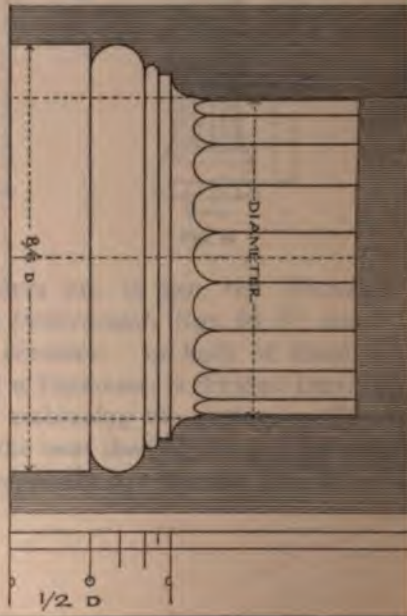

PLAN OF BASE

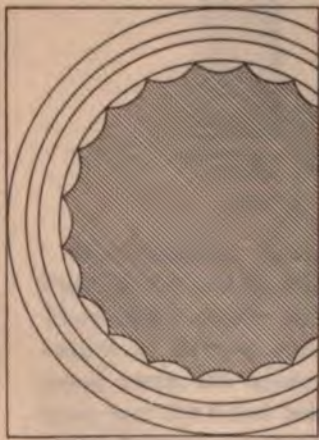

# DORIC ORDER

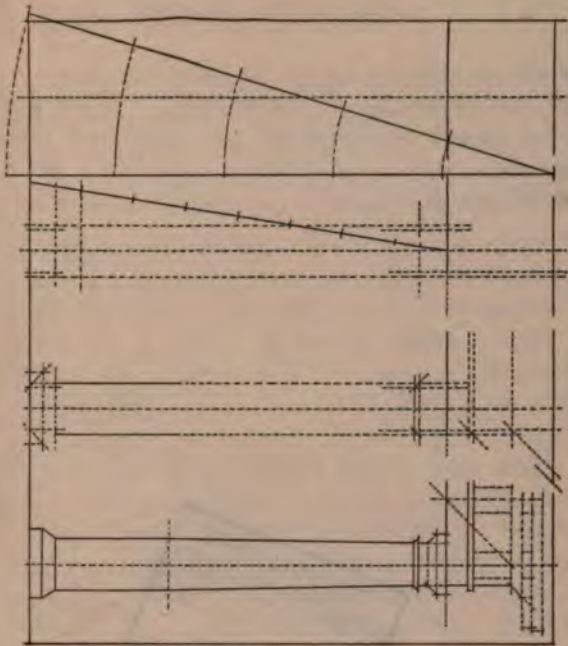

PERSPECTIVE VIEW



DRAWN TO THE SCALE  
OF ORDER IN PLATE VI



PLAN OF CAPITAL

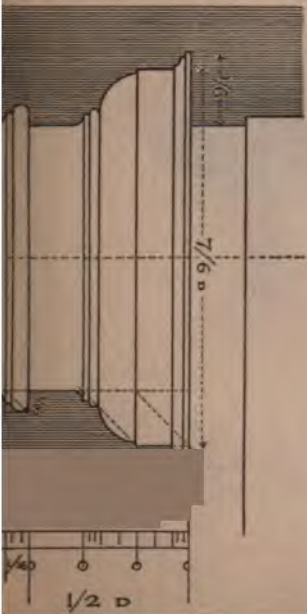

PLA

mal 7

DORIC ORDER



THE NEW YORK  
PUBLIC LIBRARY  
ASTOR, LENOX  
TILDEN FOUNDATIONS



PLAN OF



are unlike. In both of them, the lower member of the Bed Mould is a broad fillet, a sort of Upper Tænia, called the *Cap of the Triglyph*. This, unlike the Tænia below, breaks around the angles of the Triglyph, serving as a sort of crowning member, or cymatium, to both the Triglyph and the Metope.

**13.** In the **Mutulary Doric**, above the Cap of the Triglyph, is a narrow fillet that does not break around the angles and accordingly shows a broad soffit over the Metopes and at the corner of the building. These two fillets occupy the lower half of the lower quarter of the cornice. The upper half of the lower quarter, above this little fillet, is an Ovolo, and above this, the second quarter of the Cornice is occupied by a broad Fascia, called the *Mutule Band*, upon which are planted the Mutules, one over each Triglyph, which are half a Diameter wide, like the Triglyphs below them. They are broad, low, oblong brackets, crowned with a Fillet and Cyma Reversa, which also crown the Mutule Band between the brackets. On the soffit of each Mutule are thirty-six Guttæ and a drip moulding.

**14.** In the **Denticulated Doric**, Figs. 56, 57, and 58, the place of the Fillet and Ovolo above the Cap of the



FIG. 57

Triglyph is taken by a large Cyma Reversa, the soffit of which is wider over the Metopes than over the Triglyphs, as

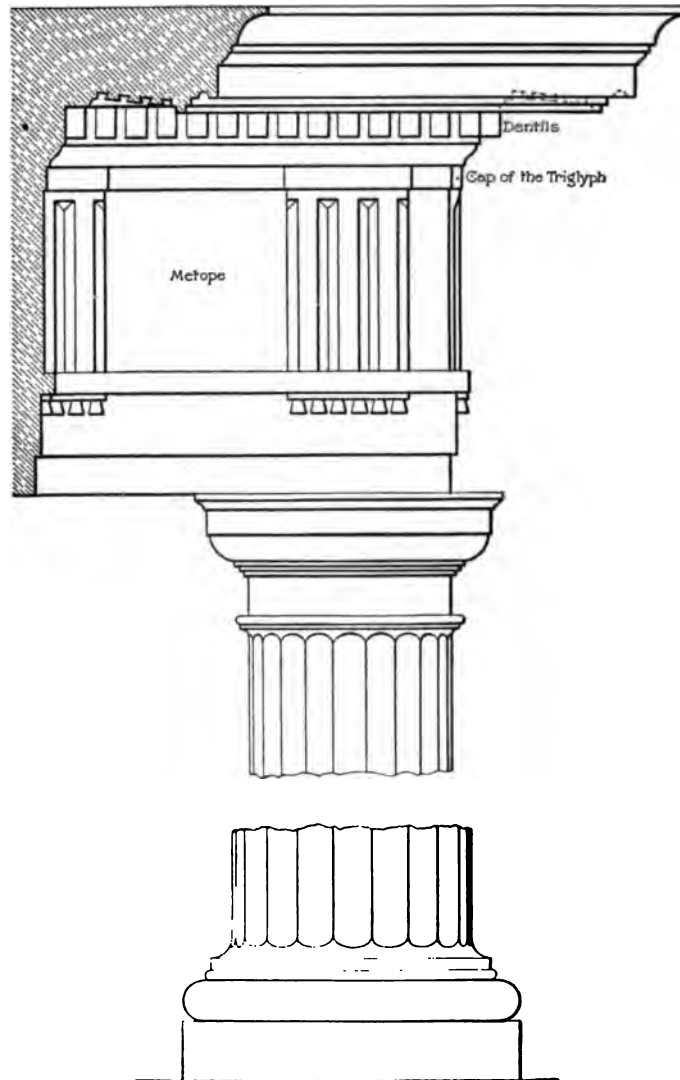

FIG. 58

is that of the small Fillet in the Mutulary. Above this moulding is a band like the Mutule Band, but instead of brackets, extending out under the Corona, it bears a row of small blocks, like teeth, called *Dentils*. These are one-eighth of a Diameter high, and are set one-eighth of a Diameter from center to center, or edge to edge. If this last dimension is divided into thirds, two of these go to the Dentil, and one to the space between it and the next one. This space is called an *Interdentil*, which is accordingly one twenty-fourth of a Diameter wide. The Dentil is thus one-eighth of a Diameter long and one-twelfth wide, or half a sixth, or of the proportions of two to three, like the Triglyph. The face of the last Dentil on the corner and the side of the first one around the corner come together in elevation without any Interdentil, giving the appearance of a *Double Dentil*, for the Dentils are square in plan and the side is just as wide as the face.

As the Triglyphs are a Diameter and a quarter on centers, or ten-eighths, there are ten Dentils to each Triglyph and Metope.

A Dentil comes just over the axis of each Column and there are three Dentils between the one over the corner Column and the Double Dentil on the corner, the farther edge of the third one being just over the face of the Frieze, or five-twelfths of a Diameter from the axis of the Column.

The last Dentil, or first half of the Double Dentil, is centered over the outer face of the bottom of the shaft, Fig. 92.

The Dentils constitute the upper member of the Bed Mould. They leave the chief part of the Corona unsupported, but the soffit of the Corona, which is slightly inclined, recalling the slope of the rafters, is not so wide as the soffit of the Mutulary Doric, owing to this encroachment of the Dentils. The Mutules, which are very shallow, have, accordingly, only eighteen Guttæ in place of thirty-six; that is, three rows, instead of six. There is also a Mutule over each Metope, as well as one over each Triglyph.

Vignola gives his Denticulated Doric a large Cavetto for a Cymatium, or gutter, instead of a Cyma Recta, and supports

the Echinus of the Capital by three fillets, instead of by a Fillet and Bead, Fig. 58.

The Triglyphs are three-quarters of a Diameter high and half a Diameter wide, Fig. 59. This width is divided into three parts, called *Shanks*. Each Shank, or *Femur*, is beveled on the edge nearly up to the top of the Triglyph, making in all two channels and two half channels. Each Shank is one-sixth of a Diameter wide and each beveled face a quarter of a sixth. The plain face of the Shank is, accord-

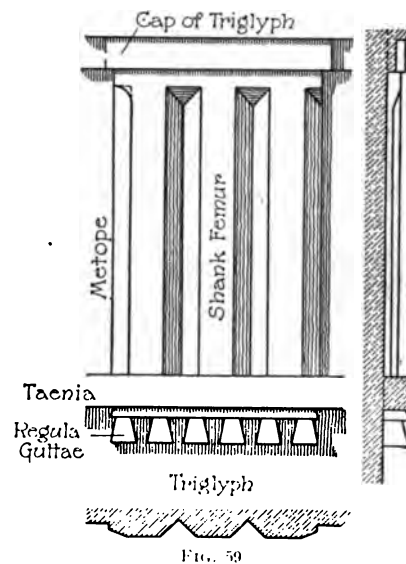

FIG. 59

ingly, one-twelfth, and just as wide as the channel. These are almost the only beveled faces to be found in the whole range of Classical Architecture, though beveled fillets are not uncommon. The two full channels are generally cut in at an angle of 45 degrees, but the two half channels on either side are shallower, and do not reach the face of the Frieze.

The Triglyphs come just over the Columns. The portion of the Frieze between the Triglyphs is called a *Metope*. It is ex-

actly square, being three-quarters of a Diameter wide. The fragment of a Metope between the last Triglyph and the corner of the Frieze is one-sixth of a Diameter wide. The face of the Metopes comes over the lower band of the Architrave, and that of the Triglyph projects slightly beyond the face of the upper Band.

The Column is eight Diameters in height, the Base, Capital, and Architrave each half a Diameter, the Frieze and Cornice each three-quarters. The total projection of the Cornice, including the Cymatium, is one Diameter. The



ELEVATION OF CLASSICAL ORDER

THE NEW YORK  
PUBLIC LIBRARY  
ASTOR LENOX  
TILDEN FOUNDATIONS

W. W. BENTLEY  
ARCHITECT  
NEW YORK



ELEVATION OF ENTABLATURE

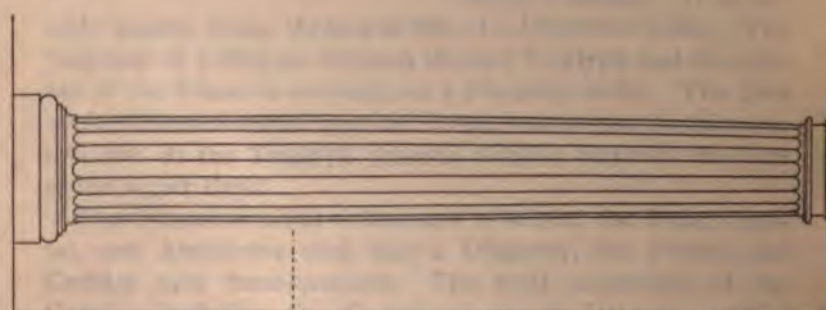
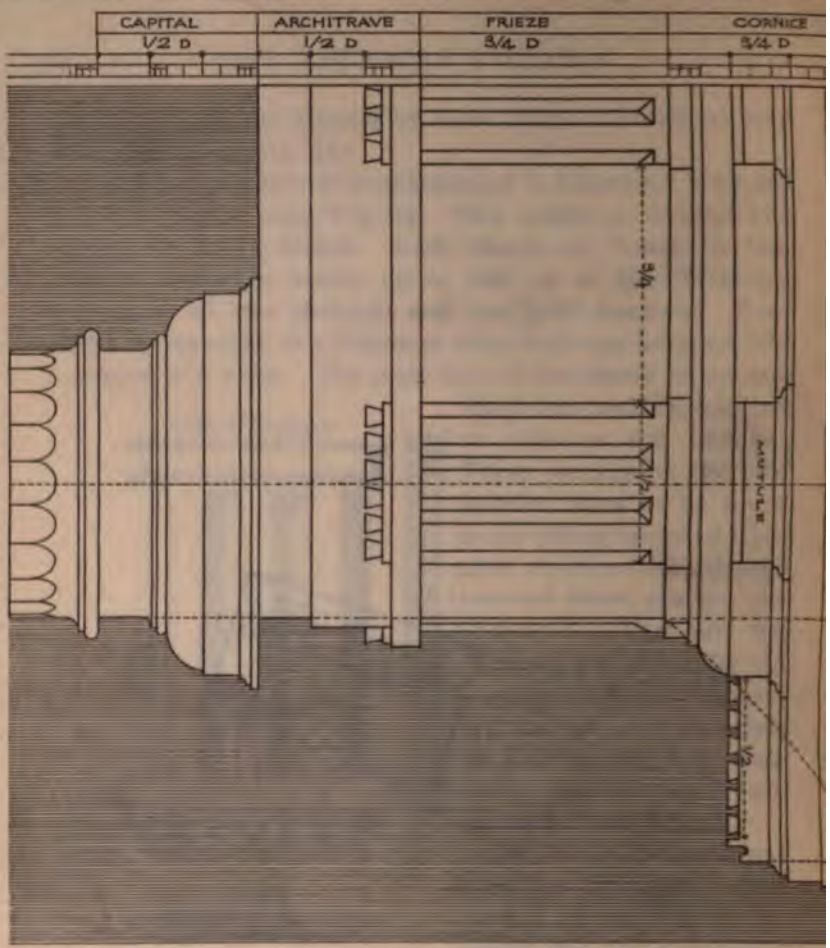

Torus  
 Plinth  
 STRAIGHT 7 DIAMETERS  
 ENTASIS 8 DIAMETERS  
 Abacus  
 Architrave

PLAN of ENTABLATURE LOOKING UP

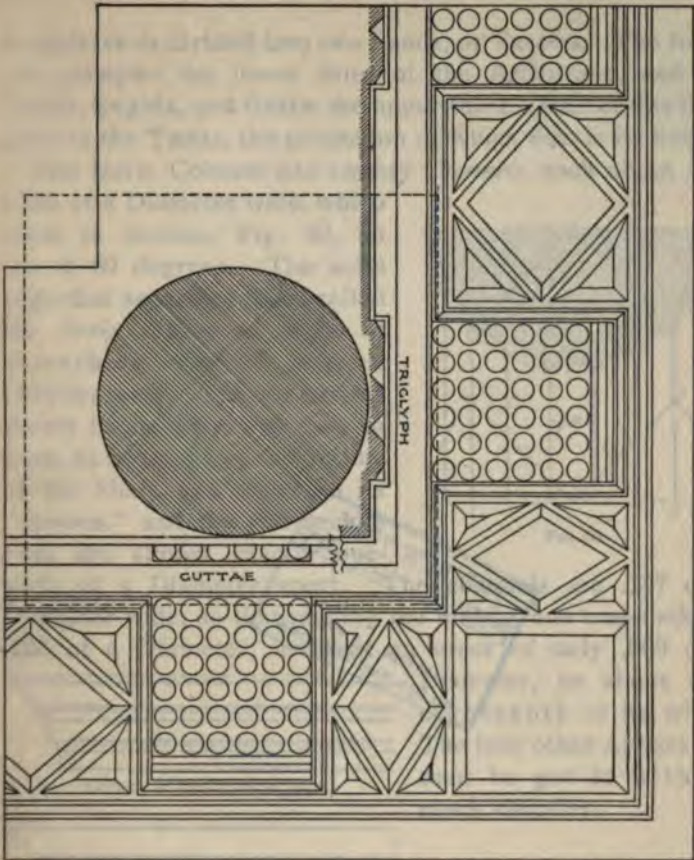

BLOCK ORDER

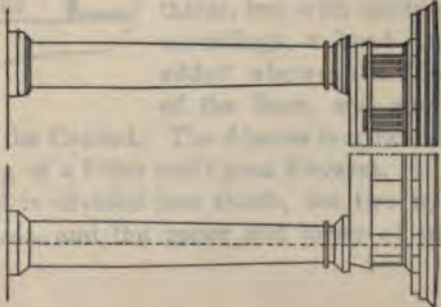

COMPLETE ORDER



- Gymnium
- Corona
- Maubia
- Red Mensid
- Mitoge
- Triclypha

DORIC ORDER

THE NEW YORK  
PUBLIC LIBRARY  
ASTOR, LENOX  
TILDEN FOUNDATIONS

Architrave is divided into two Bands, or Fascias. The lower one occupies the lower third of the Architrave, and the Tænia, Regula, and Guttæ the upper third. Half of this third goes to the Tænia, the projection of which equals its height.

The Doric Column has twenty Channels, each about one-sixth of a Diameter wide, which show in section, Fig. 60, an arc of 60 degrees. The solid edge that separates them, called the Arris, makes an angle of something over 90 degrees (102 degrees). The ten Arrises shown in elevation are easy to draw, as two come on the outline of the Shaft, two come on its "corners," and the two middle ones are almost exactly one-sixth of a Diameter apart.

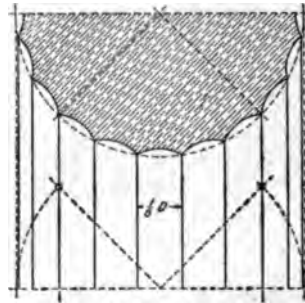
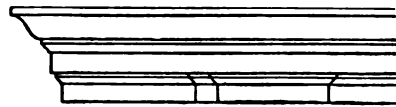

FIG. 60

The channels are .157 of a Diameter wide, so that making the middle one one-sixth, or .166 of a Diameter, involves an error of only .009 of a Diameter, or about one-eighteenth of its width. The four other Arrises can then be put in without much difficulty.



Cornice of the Basilica Julia

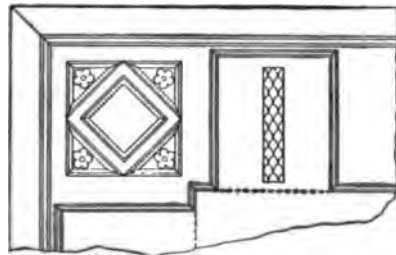

FIG. 61

below the Echinus of the Capital. The Abacus is crowned by a cymatium consisting of a Fillet and Cyma Reversa. If the height of the Capital is divided into thirds, the two upper thirds again into thirds, and the upper and lower of these

15. The Doric Base and Capital, Figs. 54 and 58, are divided, like the Tuscan, into halves and thirds, but with additional mouldings, a bead being added above the Torus of the Base, and another

still again into three equal parts, all the horizontal lines of the Capital will be determined, as shown in Plate V.

Vignola's Denticulated Doric is imitated closely from the Doric Order of the Theater of Marcellus, and the Mutulary, which he has been thought to have invented, seems to have been derived from the Doric Order of the Basilica Julia, Fig. 61. There are no Roman Doric temples.

TABLE OF THE DORIC ORDER—PLATES VII, VIII, IX, AND X

$\frac{1}{2} D$ equals	{	height of Frieze. height of Cornice. projection of Corona (Denticulated). projection of Mutule (Mutulary). width of Metope.
$\frac{1}{2} D$ equals		height of Plinth.
$\frac{1}{2} D$ equals	{	projection of Plinth. projection of Abacus. height of Abacus. height of Necking. height of Echinus and Bead. height of Lower Band. height of Guttæ, Regula, and Tænia. width of Shank. width of Corner Metope.
$\frac{1}{2} D = \frac{2}{3} D$ equals	{	height of Base, including the Cincture. height of Capital. height of Architrave. width of Triglyph.
$\frac{1}{2} D$ equals		height of Dentils.
$\frac{1}{2} D$ equals	{	width of Dentils. height of Tænia. projection of Tænia.
$\frac{1}{2} D$ equals	{	height of Astragal. projection of Astragal.
$\frac{1}{2} D$ equals		width of Interdentils.



THE NEW YORK  
PUBLIC LIBRARY  
ASTOR, LENOX  
TILDEN FOUNDATIONS

ELEVATION OF ENTABLATURE

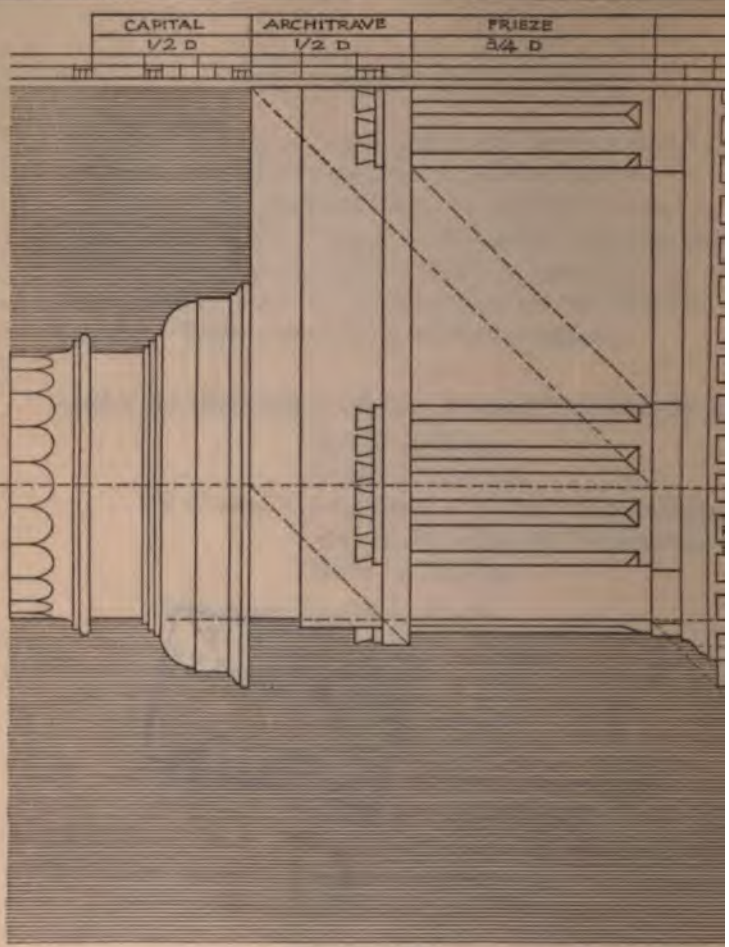

# DORIC ORDER [DENTICULATED]

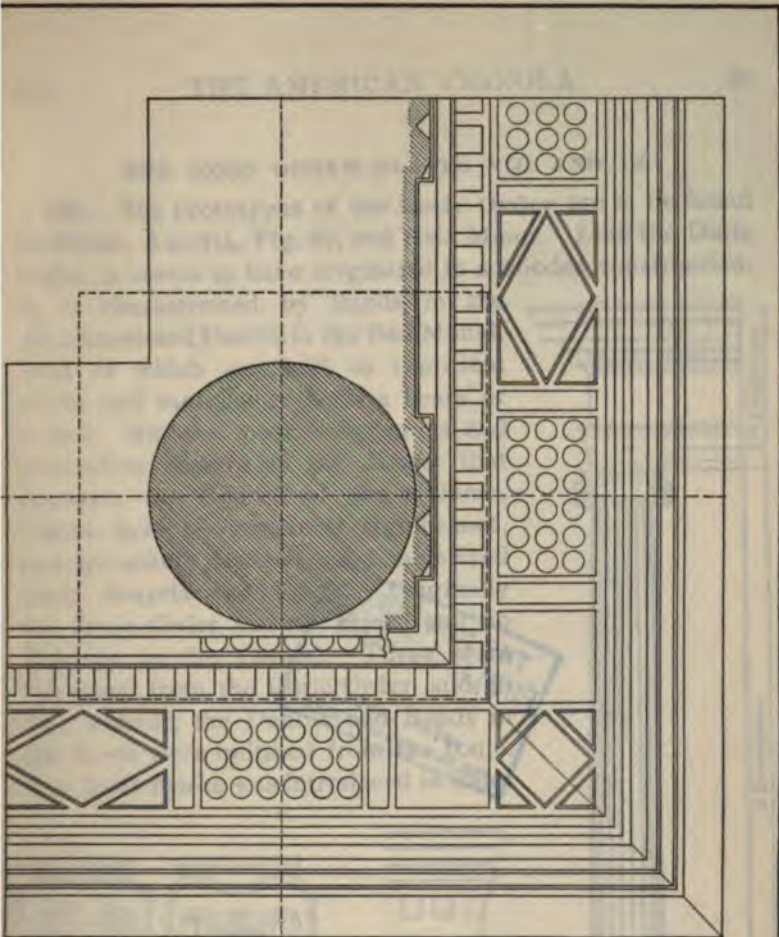

PERSPECTIVE VIEW

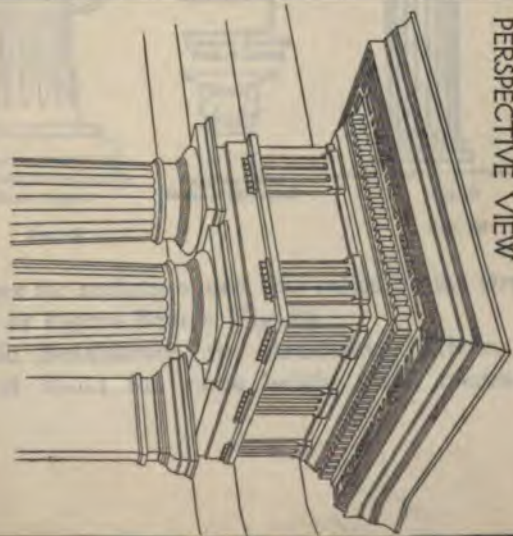

COMPLETE ORDER

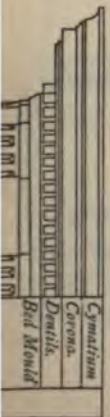





THE IONIC ORDER—PLATES VIII AND IX

16. The prototypes of the **Ionic Order** are to be found in Persia, Assyria, Fig. 62, and Asia Minor. Like the Doric Order, it seems to have originated in a wooden construction. It is characterized by Bands in the Architrave and Dentils in the Bed Mould, both of which are held to represent sticks laid together to form a beam or a roof. But the most conspicuous and distinctive feature is the *Scrolls* that decorate the Capital of the Column. These have no structural significance, and are purely decorative forms derived from Assyria and Egypt. Originally the Ionic Order had no Frieze and no Echinus in the Capital. These were borrowed from the Doric Order, and, in like manner, the Dentils and Bands in the Doric were imitated from the Ionic. The Ionic Frieze was introduced in order



Ionic  
FIG. 63

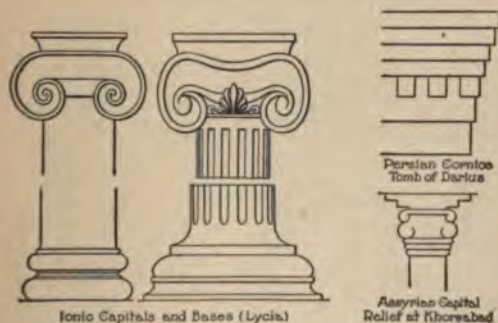

FIG. 62

to afford a place for sculpture, and was called by the Greeks the *Zoöphorus*, or Figure Bearer, Fig. 64.

In the Ionic Entablature, the Architrave, Frieze, and Cornice are of about the same height, each measuring

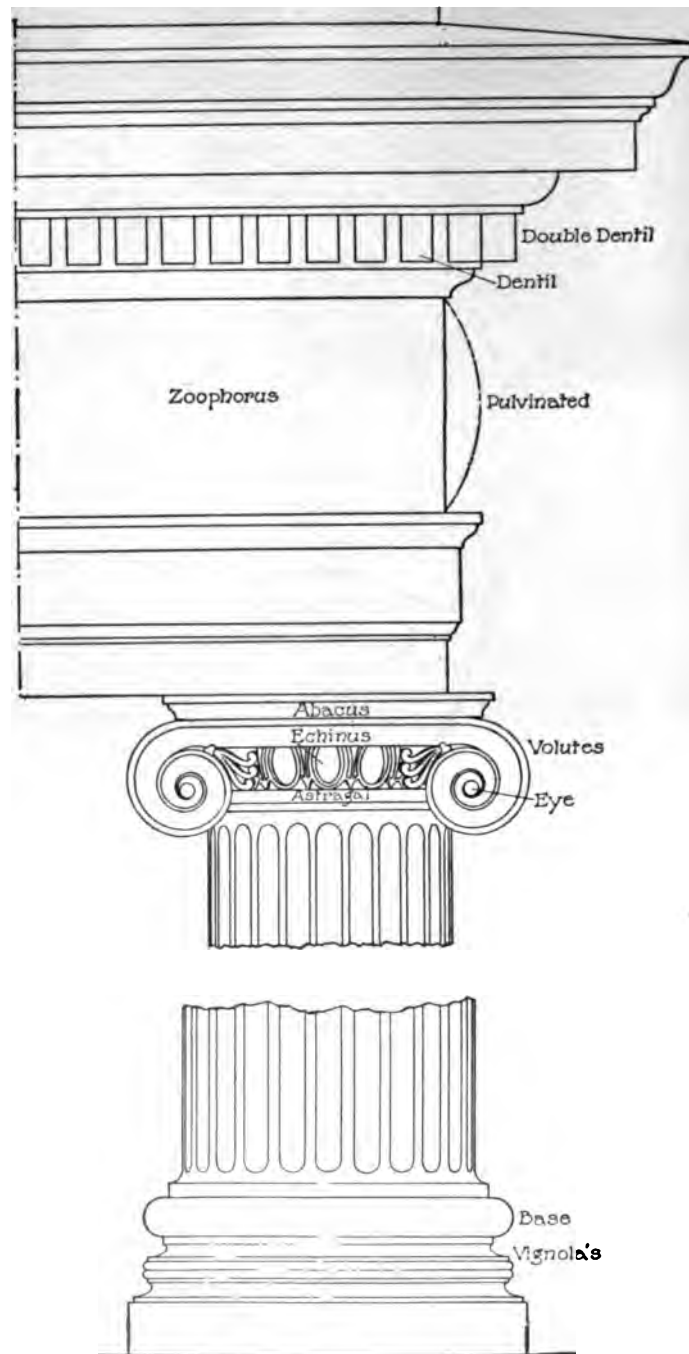
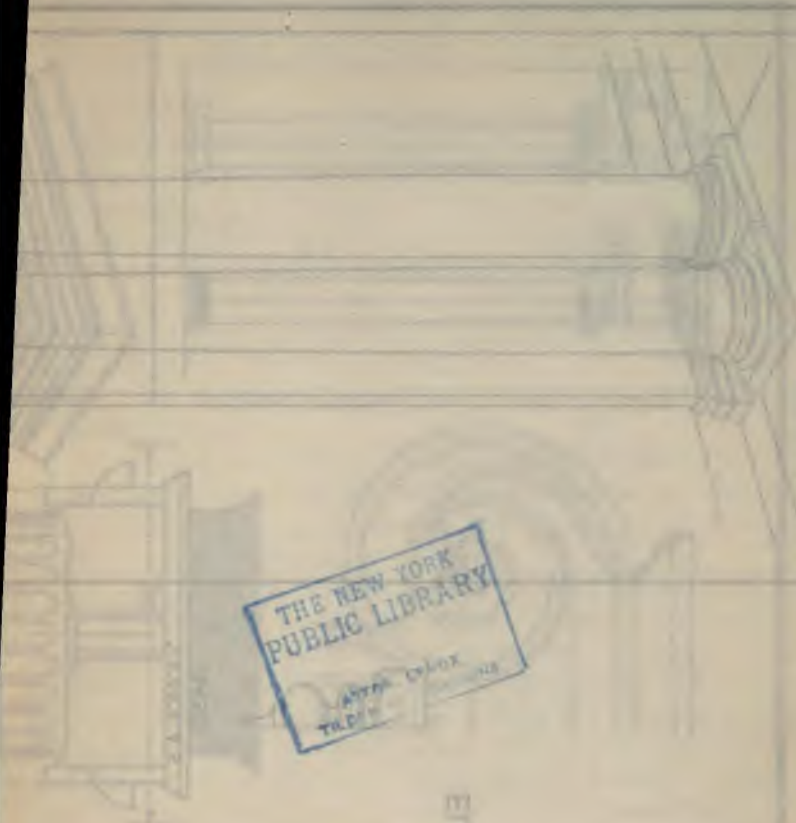

FIG. 64

SEA BUT

PERSPECTIVE VIEW



THE NEW YORK PUBLIC LIBRARY  
ASTOR LENOX TILDEN FOUNDATION

SECTION OF CAPITAL

SECTION OF COLUMN

BASE

ELEVATION OF CAPITAL

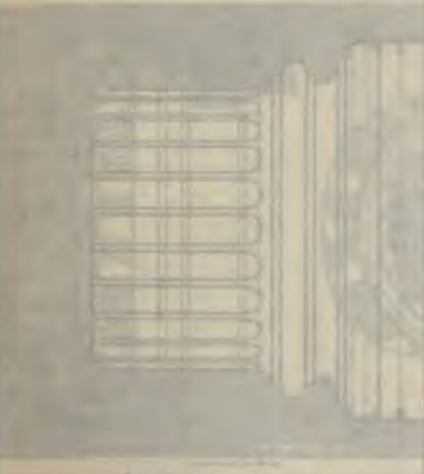

REV

PERSPECTIVE VIEW

DRAWN TO THE SCALE  
OF ORDER IN PLATE IX

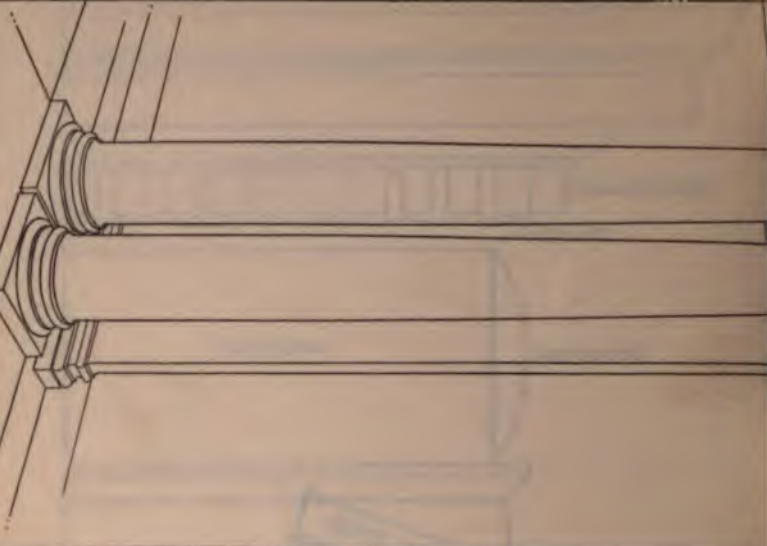

VIGNOLA'S  
BASE

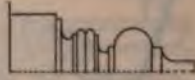

ELEVATION OF CAPITAL BASE

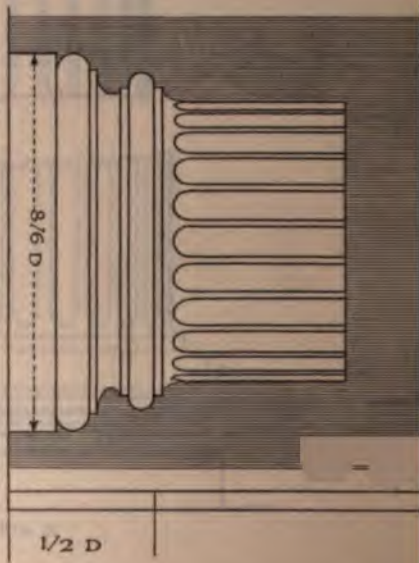

PLAN OF BASE

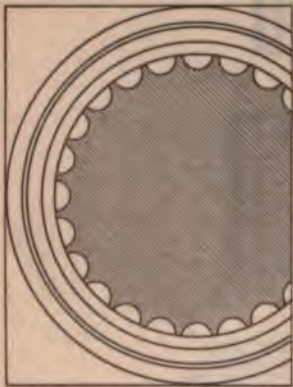

# IONIC ORDER

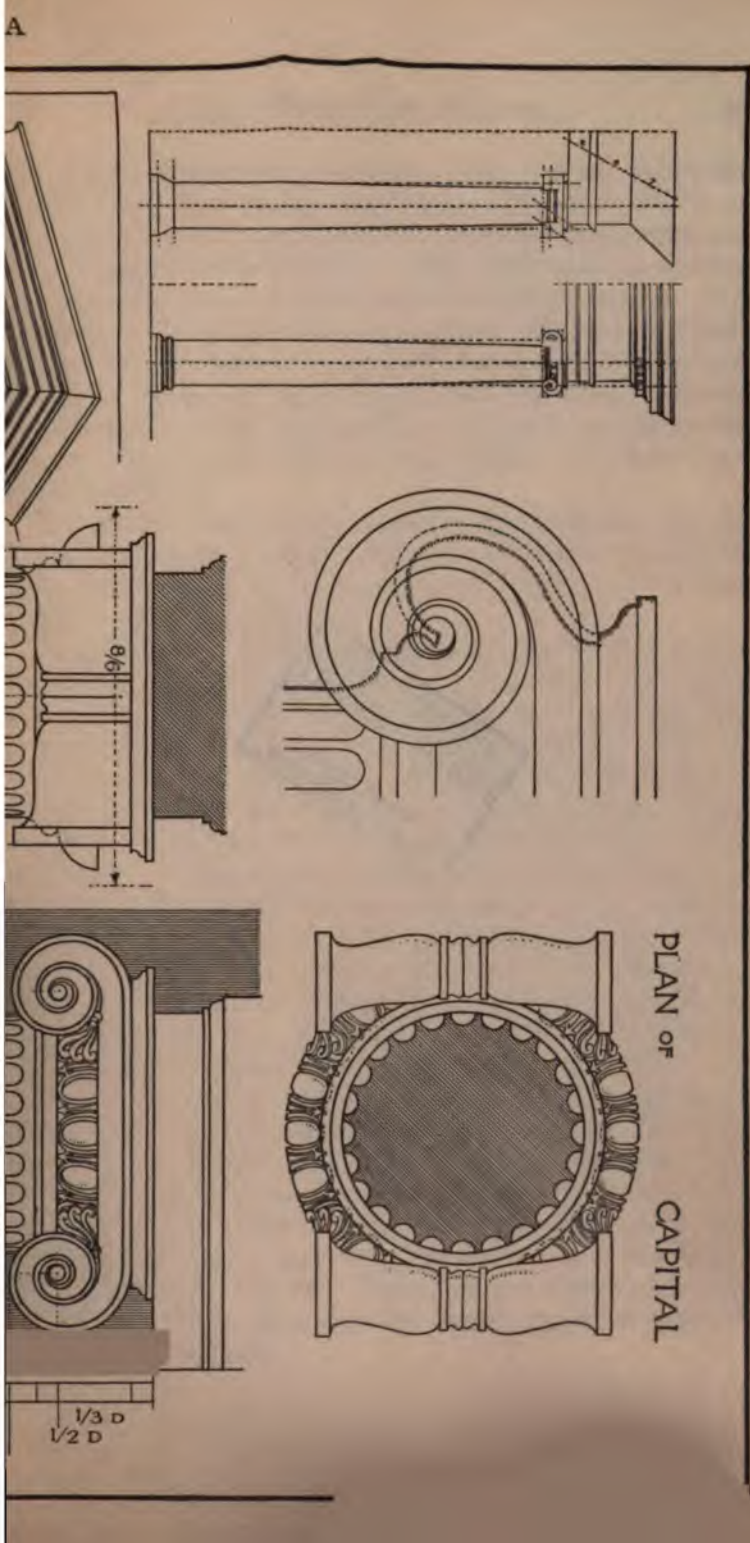



about three-quarters of a Diameter. But Vignola makes the Architrave a little smaller and the Cornice a little larger, so that they measure, respectively, five-eighths, six-eighths, and seven-eighths of a Diameter. The Architrave is divided into five parts, each an eighth of a Diameter in height. The upper one is occupied by a large Cyma Reversa and Fillet, which take the place of the Doric Tænia. Below are two fascias, or bands, of equal height, each measuring a quarter of a Diameter. The lower one is crowned by an Ovolo and Fillet. The French often use three bands, as in the Corinthian Architrave.

The Ionic Frieze is plain, except for the sculpture upon it. It sometimes has a curved outline, as if ready to be carved, and is then said to be *Pulvinated*, from *Pulvinar*, a bolster, which it much resembles.

The Cornice is much like that of the Denticulated Doric, which was derived from it, but has no Mutules. The upper half, as in the Doric, is taken up by the Cymatium and Corona, and the lower half by the Bed Mould. This is divided into four equal parts, of which the upper one is given to an Ovolo, the lower to a Cyma Reversa and Fillet, and the two middle ones to a Dentil Band and Fillet. Upon this band are planted the Dentils, which are one-sixth of a Diameter high, and are set one-sixth on centers, or on edges, instead of one-eighth, as in the Denticulated Doric. Two-thirds of this sixth go to the width of the Dentil and one to the space between, or Interdentil. The Dentil is, accordingly, one-ninth of a Diameter wide, and the Interdentil one-eighteenth, instead of a twelfth and a twenty-fourth. A Dentil is put on the axis of a column, and an Interdentil comes just over the outer line of the Frieze. There is, apparently, a Double Dentil on the corner, the outer face of which is two-thirds of a Diameter, or four-sixths, from the axis of the column. The first half of it, as in the Denticulated Doric, comes over the outer face of the lower end of the shaft, Fig. 93. There are two Dentils between the one over the column and the Double Dentil, in place of three, as in the Doric.



The Ionic Capital, like the Doric, has an Echinus and an Abacus crowned by a Cyma Reversa and Fillet. But generally it has no Necking, and it is, accordingly, only two-sixths of a Diameter in height, or one-third instead of one-half. Both the Echinus and the Cymatium that crown the



FIG. 65

Abacus are larger than in the Doric, and the face of the Abacus smaller, and the Echinus projects in front of the Abacus, instead of being covered by it. The Abacus and its Fillet extend beyond the Echinus on either side, and are curled up into the Scrolls, or *Volutes*, Fig. 65, the whole height of

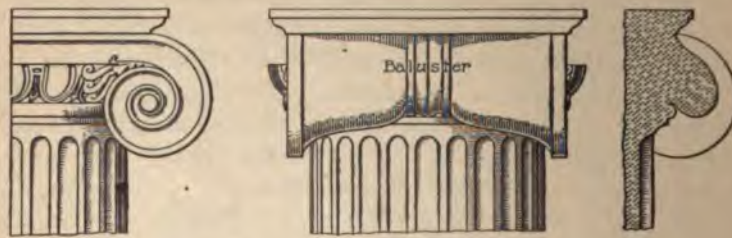

FIG. 66

which is a half Diameter, measuring down from the Architrave. The *Eyes* of the Scrolls are one-third of a Diameter from the top, on the line separating the bottom of the Capital from the top of the Astragal that crowns the Shaft. They are just one Diameter apart on centers, coming over the

outer lines of the lower end of the Shaft, and the inner edges of the Scrolls are two-thirds apart. The Echinus is generally carved with Eggs and Darts, three of which show between the Scrolls, the next one on either side being hidden by sprigs of Honeysuckle Ornament. These Scrolls, Fig. 66, show on the sides a series of mouldings called the *Baluster*, or *Bolster*. The term Abacus is generally held to apply only to the *Cyma Reversa* and *Fillet*, above the Scrolls.

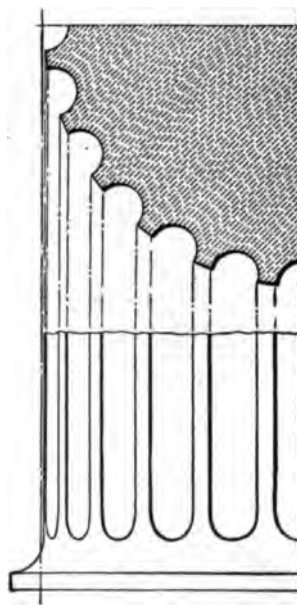

FIG. 67

The Shaft of the column is ornamented with twenty-four *Flutings*, Fig. 67, semicircular in section, which are separated not by an *Arris*, but by a *Fillet* of about one-fourth their width. This makes the *Flutings* only about two-thirds as wide as the *Doric Channels*, or about one-ninth of a *Diameter*, instead of one-sixth. Four-fifths of one-twenty-fourth of the circumference is .106 of a *Diameter*, while one-ninth of the diameter is .111, a difference of less than a twentieth.

The typical Ionic base is considered to consist mainly of a Scotia, as in some Greek examples, Fig. 69. It is common,

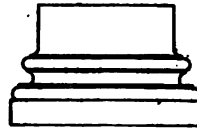
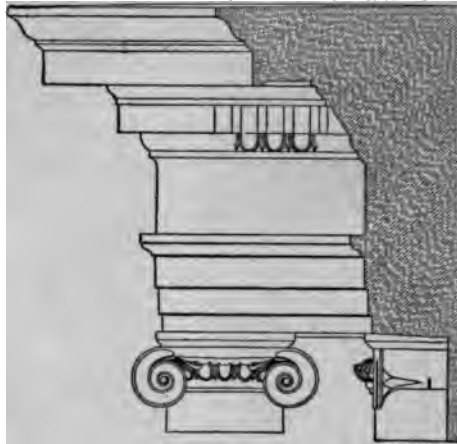
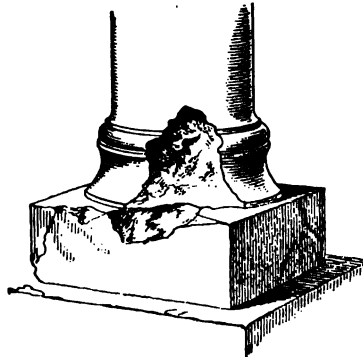
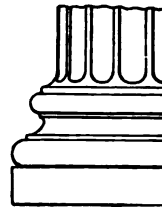

FIG. 68



Base of Choragic Column (Athens)

FIG. 69



Attic Base

FIG. 70

however, to use instead what is called the *Attic Base*, Fig. 70, consisting of a Scotia and two Fillets between two large

THE VA

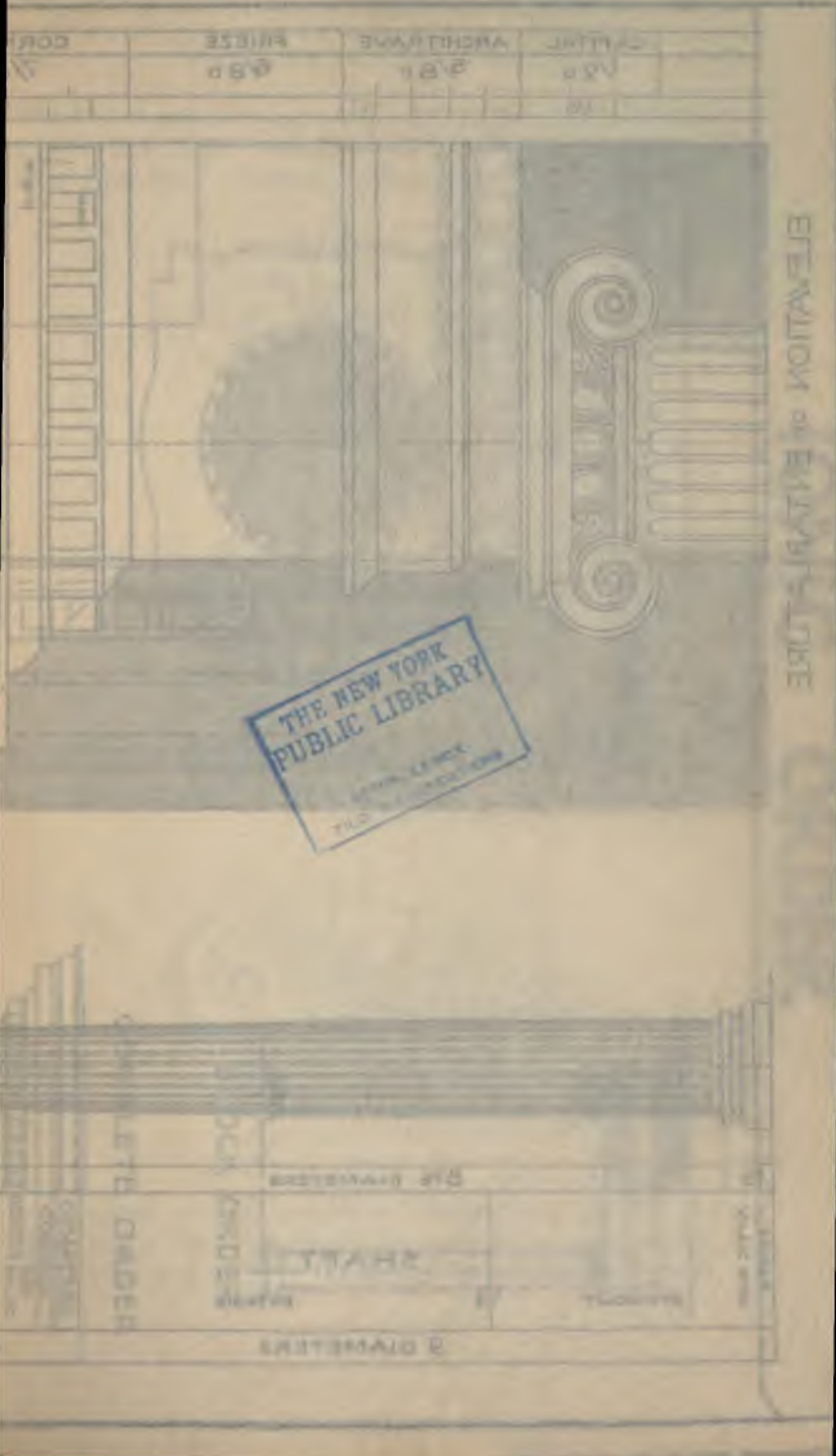

ELEVATION of EGYPTIAN TEMPLE

THE NEW YORK  
PUBLIC LIBRARY  
ASTOR, LENOX,  
TILDEN FOUNDATIONS

3 DIAMETERS

2 DIAMETERS

1 DIAMETER

1/2 DIAMETER

ELEVATION OF ENTABLATURE

CAPITAL	ARCHITRAVE	FRIEZE	CORNICE
$\frac{1}{2}D$	$\frac{5}{8}D$	$\frac{6}{8}D$	$\frac{7}{8}D$
$\frac{1}{3}$			

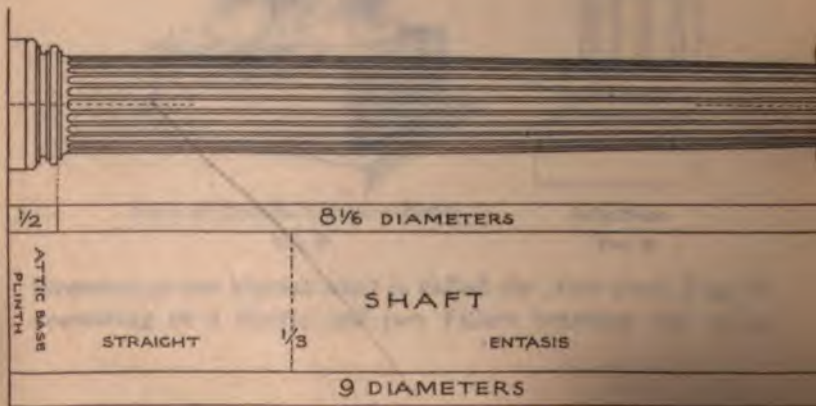
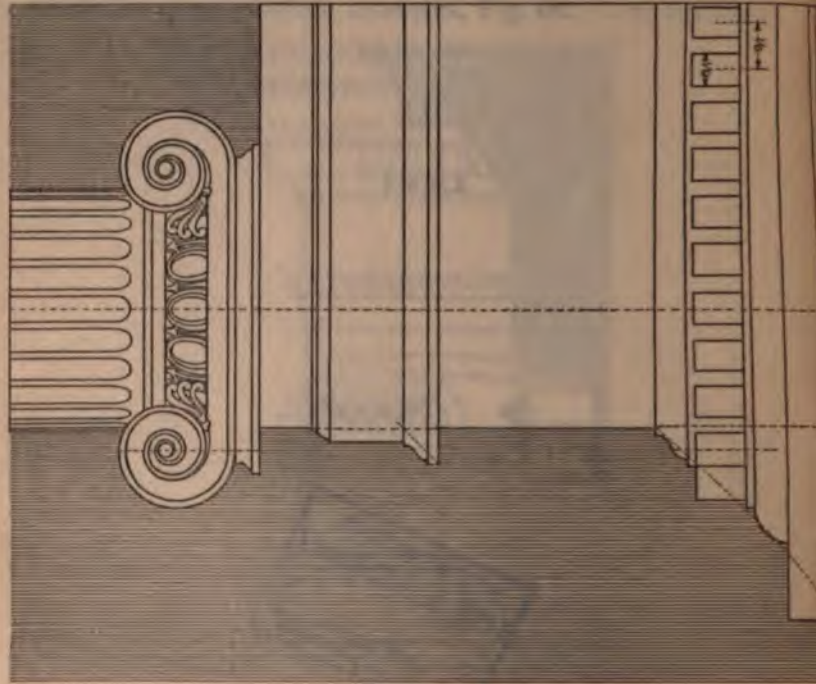



# IONIC ORDER



THE NEW YORK  
PUBLIC LIBRARY  
ASTOR, LENOX  
TILDEN FOUNDATIONS

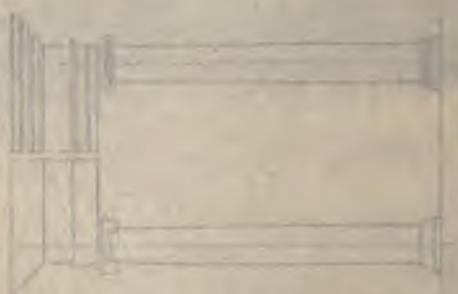

COMPLETE ORDER  
BLOCK ORDER

IONIC CAPITAL	1/2
IONIC COLUMN	1/2
IONIC ABACUS	1/2
IONIC CAPITAL	1/2
IONIC COLUMN	1/2
IONIC ABACUS	1/2

Toruses, mounted on a plinth, the whole half a Diameter high. The Plinth occupies the lower third, or one-sixth of a Diameter. Vignola adopted for his Ionic Order a

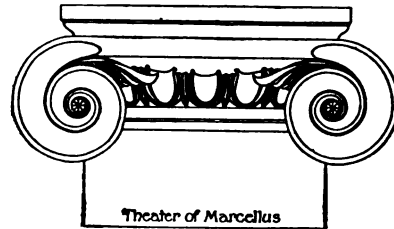

FIG. 71

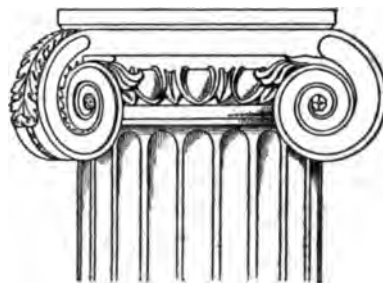

FIG. 72

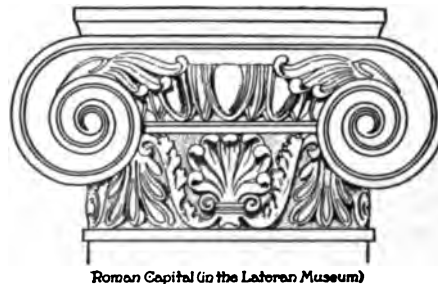

FIG. 73

modification of the Attic Base, substituting for the single large Scotia two small ones, separated by one or two Beads and Fillets and omitting the lower Torus, Fig. 64.



principal ancient examples of the Ionic Order in Rome are those of the Theater of Marcellus, Fig. 71, and the Temple of Fortuna Virilis, Fig. 72.

The Ionic Capital sometimes has a necking like the Doric, which is then generally decorated, Fig. 73. Sometimes, also, the four faces of the Capital are made alike, double scrolls occurring at the corners, where they project at an



Scamozzi Capital

FIG. 74

angle of 45 degrees. In this case there is no Baluster, and the Capital resembles the upper portion of a Composite Capital. It is then sometimes called the Roman Ionic Capital, or the Scamozzi Capital, Fig. 74, from the name of the architect Scamozzi, who frequently employed it.

Almost all the dimensions of the Ionic Order can be expressed in terms of sixths of a Diameter, as appears in the following Table:

**TABLE OF THE IONIC ORDER—PLATES XI, XII, AND XIII**

$\frac{5}{6} D$  equals height of Architrave.

$\frac{2}{3} D = \frac{4}{6} D$  equals height of Frieze.

$\frac{1}{3} D$  equals { height of Cornice.  
projection of Cornice.

$\frac{1}{6} D = \frac{1}{6} D$  equals height of each Band.

$\frac{1}{6} D$  equals { projection of Plinth.  
height of Plinth.  
height of Dentils.  
distance of Dentils, o. c.  
projection of Abacus.

$\frac{1}{2} D = \frac{1}{2} D$  equals height of Capital.

$\frac{1}{2} D = \frac{1}{2} D$  equals  $\left\{ \begin{array}{l} \text{height of Base.} \\ \text{height of Scrolls.} \end{array} \right.$

$\frac{2}{3} D = \frac{1}{3} D$  equals  $\left\{ \begin{array}{l} \text{distance between Scrolls.} \\ \text{distance from Axis to outer face} \\ \text{of Double Dentil.} \end{array} \right.$

$\frac{1}{2} D$  equals upper Diameter.

$1 D = \frac{1}{2} D$  equals  $\left\{ \begin{array}{l} \text{lower Diameter.} \\ \text{distance of Eyes of Scrolls, o. c.} \\ \text{length of Baluster.} \end{array} \right.$

$\frac{2}{3} D$  equals width of Abacus.

$1\frac{1}{2} D = \frac{2}{3} D$  equals  $\left\{ \begin{array}{l} \text{width of Plinth.} \\ \text{width of Echinus (minus).} \end{array} \right.$

$1\frac{1}{2} D = \frac{2}{3} D$  equals width of Scrolls (minus).

$\frac{1}{2} D$  equals  $\left\{ \begin{array}{l} \text{width of Dentil.} \\ \text{width of Fluting.} \end{array} \right.$

$\frac{1}{12} D$  equals  $\left\{ \begin{array}{l} \text{height of Astragal.} \\ \text{projection of Astragal.} \end{array} \right.$

$\frac{1}{12} D$  equals width of Interdentil.

---

THE CORINTHIAN ORDER—PLATES X AND XI

17. The three distinguishing characteristics of the Corinthian Order, Fig. 75, are a tall bell-shaped Capital, a series of small brackets, called *Modillions*, that support the Cornice instead of *Mutules*, in addition to the Dentils, and a general richness of detail, which is enhanced by the use of the *Acanthus leaf*, Fig. 76, in both Capitals and *Modillions*.

The height of the Cornice, Fig. 77, is divided into five parts. The two lower and the two upper parts resemble the lower and upper halves of the Ionic Cornice. The middle fifth is occupied by a *Modillion Band*, which carries the *Modillions*, or brackets. These, as well as the *Modillion*

Band, are crowned by a small Cyma Reversa. They consist of a double scroll, below which is an Acanthus leaf. Each Modillion is half a Diameter long, one-fifth high, and as wide as a Dentil and two Interdentils; that is to say, two-ninths of a Diameter. They are set two-thirds of a Diameter on centers, one being over the axis of the corner Column, and one over the outer face of the Double Dentil. The soffit of the Corona between the Modillions is occupied by a sinkage with mouldings, called a *Caisson*, in the middle of which there is a large *Rosette*.

As the Modillions are two-thirds of a Diameter on centers, or four-sixths, and the Dentils are one-sixth, on centers, it follows that there are four Dentils to each Modillion; i. e., a Dentil under every Modillion, and three between. As in the Ionic Order and in the Denticulated Doric, the last Dentil, which is the first half of the Double Dentil, is centered over the face of the lower Diameter of the column, Fig. 94.

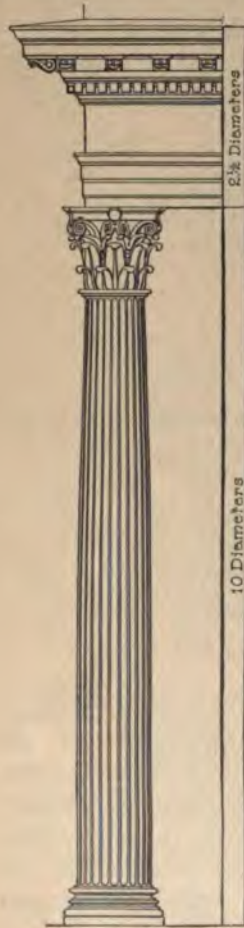

Corinthian

FIG. 75



FIG. 76

The Architrave, which is three-quarters of a Diameter high, has three Bands and a large cymatium, which is as wide as the first Band. The two lower Bands occupy the

PLATE III



THE NEW YORK  
PUBLIC LIBRARY  
ASTOR LENOX  
TILDEN FOUNDATION

TEMPORARY ORNAMENTAL BASE

PLATE III

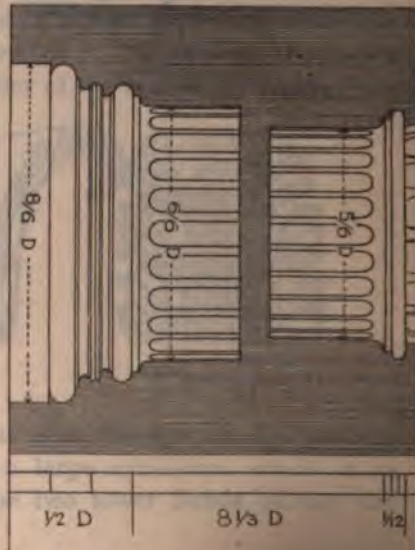
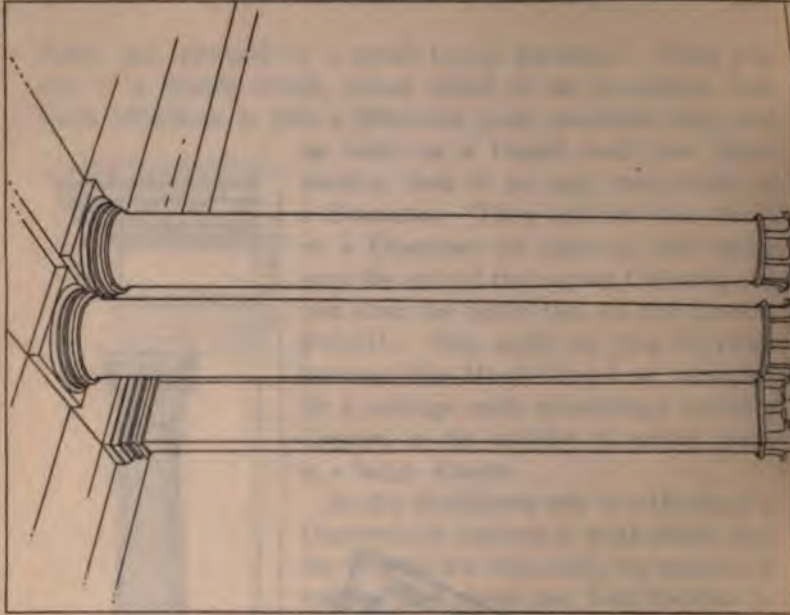

ELEVATION OF CAPITAL AND BASE

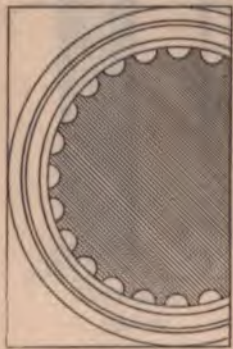

PLAN OF BASE

# CORINTHIAN ORDER

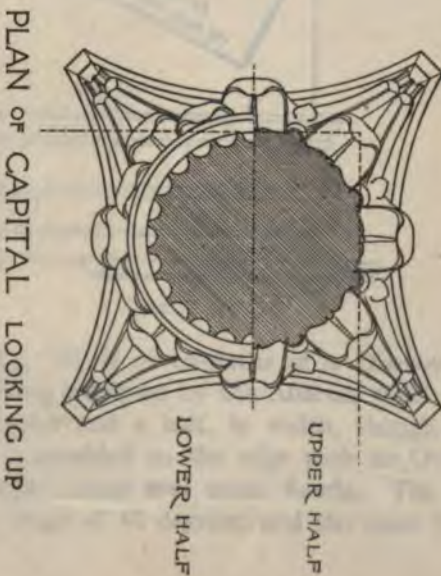
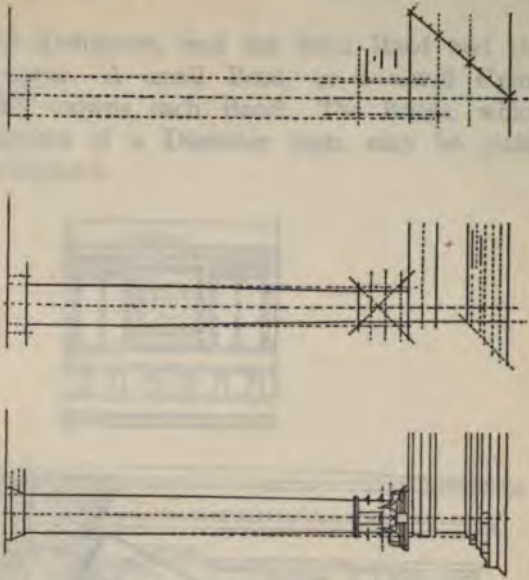

PLAN OF CAPITAL LOOKING UP

PERSPECTIVE VIEW



DRAWN TO THE SCALE OF ORDER IN PLATE XI

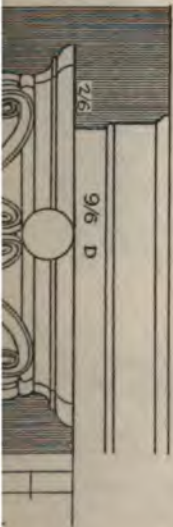



lower half of the Architrave, and the third Band and the cymatium the upper. A small Bead, or a small Cyma Reversa, generally crowns each Band. The Frieze, which is also three-quarters of a Diameter high, may be plain, pulvinated, or sculptured.

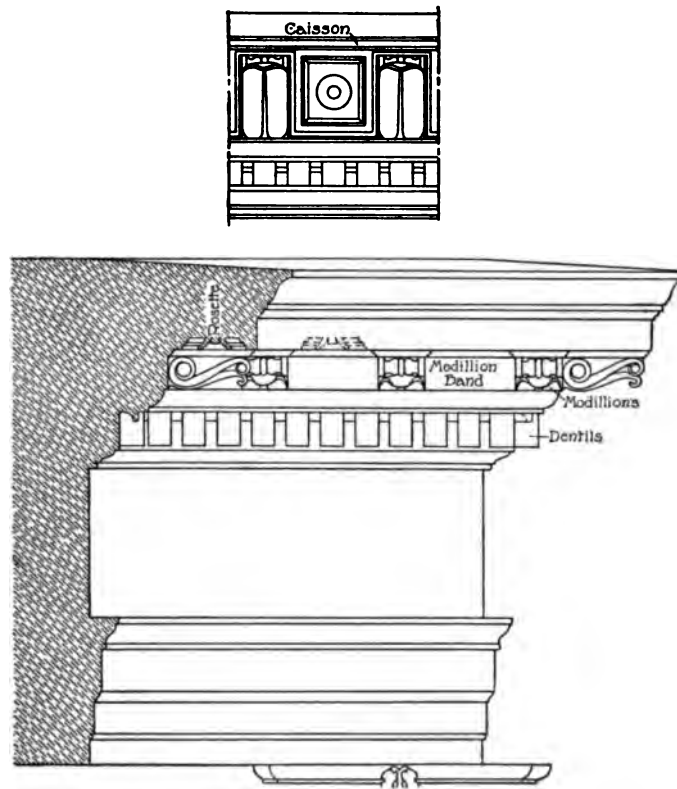

FIG. 77

The Capital, Fig. 78, is seven-sixths of a Diameter high, the upper sixth being taken up by the Abacus, which is nine-sixths, or a Diameter and a half, in width, though it does not look so. It is moulded on the edge with an Ovolo and Fillet above a large Congé and small Fascia. The corners are cut off at an angle of 45 degrees, and the sides hollowed



out in a curve of 60 degrees. The width across from curve to curve is seven-sixths of a Diameter. Each face of the Abacus bears a flower, called the *Fleuron*, that springs from a small bud above the middle leaf.

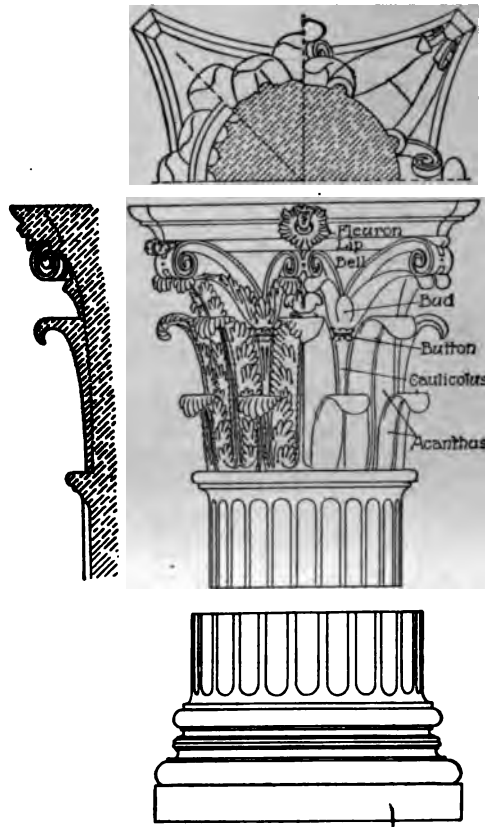
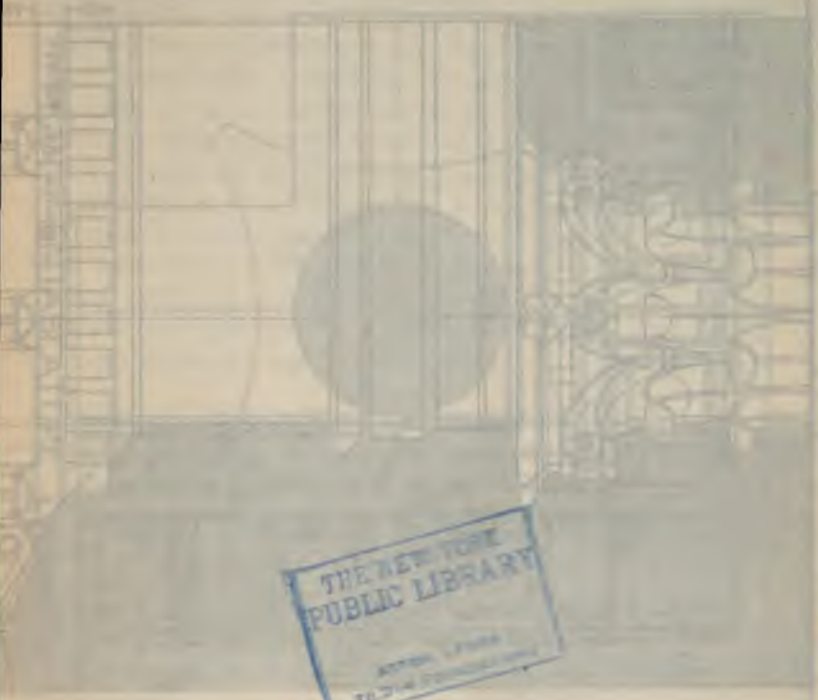

FIG. 78

The *Bell* of the capital, Fig. 79, is one Diameter high, or six-sixths; it terminates under the Abacus in a Beak Moulding called the *Lip of the Bell*, which measures seven-sixths of a Diameter across, its greatest projection coming just under the least projection of the upper line of the Abacus. The lower two-sixths are covered by a row of eight Acanthus

THE NEW YORK PUBLIC LIBRARY

ARCHITECT	ARCHITECT	ARCHITECT	CAPITAL
W. B. MERRILL	W. B. MERRILL	W. B. MERRILL	W. B. MERRILL



THE NEW YORK  
PUBLIC LIBRARY  
ASTOR, LENOX  
TILDEN FOUNDATIONS

ELEVATION OF THE COLUMN CAPITAL



W. B. MERRILL ARCHT. N. Y.

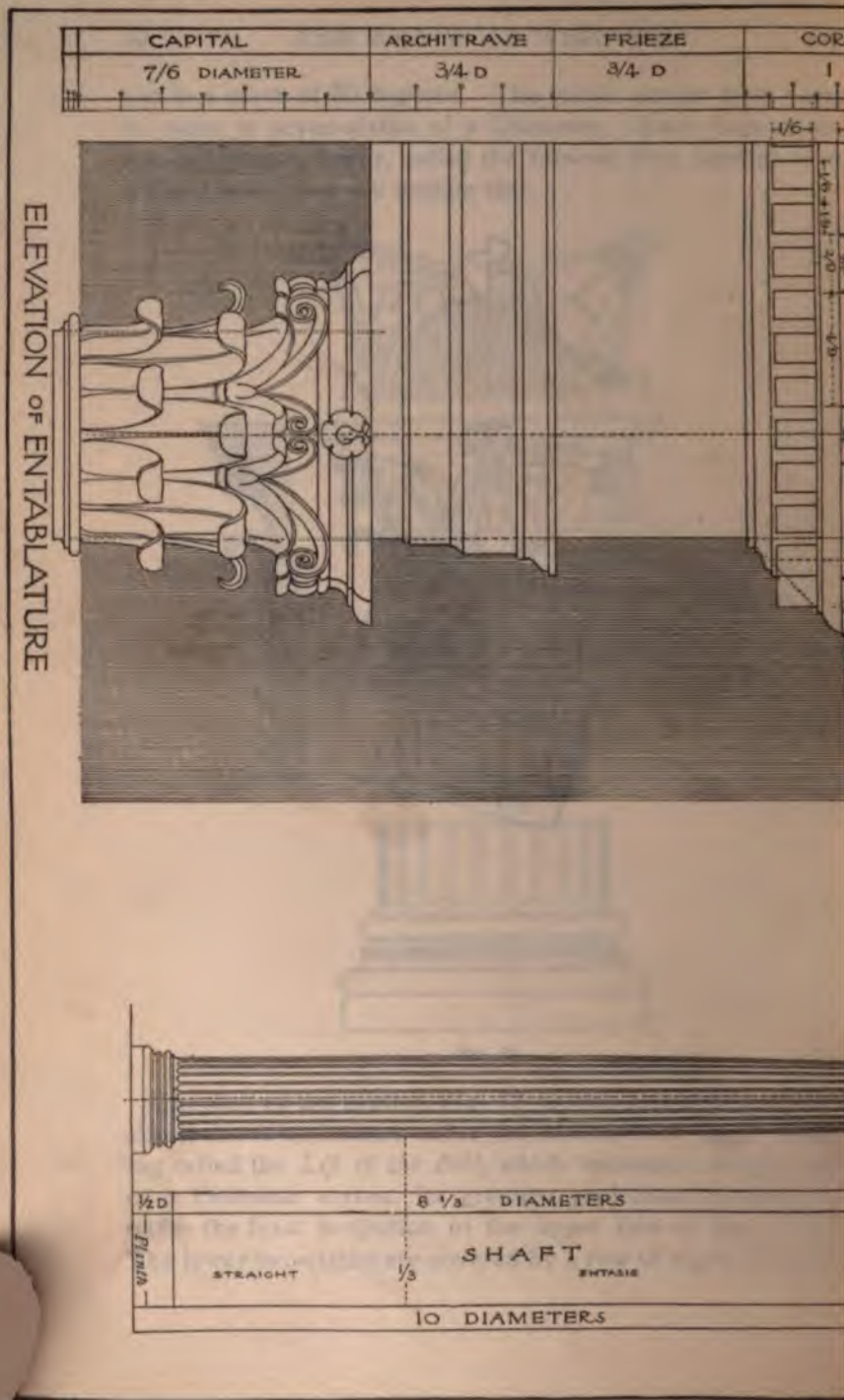

ELEVATION OF ENTABLATURE

# CORINTHIAN ORDER

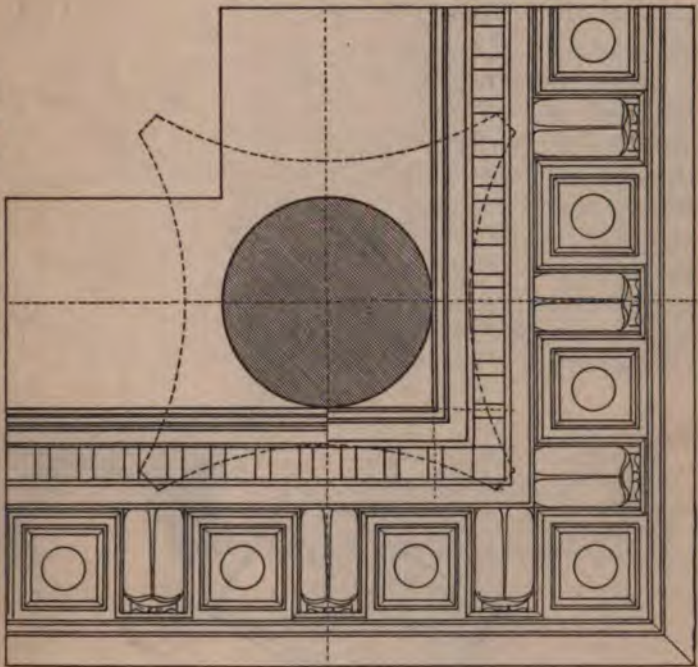

PLAN of ENTABLATURE LOOKING UP

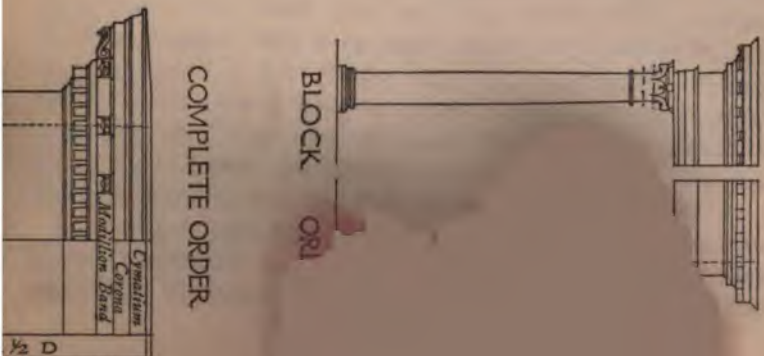

COMPLETE ORDER

1/2 D

IOLA

Compton



leaves, which bend down at the top to the extent of half a sixth, or a quarter of their own height. The next two-sixths show a similar row of eight leaves, set alternately with those below, four facing the sides of the Capital, and four the corners. Like those of the first row, they spring from the Astragal at the top of the Shaft, and the mid-rib of each leaf shows between two lower leaves, it being really four-sixths high. These also bend down half a sixth. Between the eight leaves of the second row are eight *Caulicoli*, or cabbage stalks, which terminate in a *Button*, upon which rests a sort of *Bud*, which divides into two leaves. These turn right and left, the larger one toward the corner of the Capital, the smaller toward the side or front under the

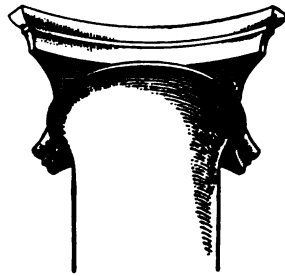
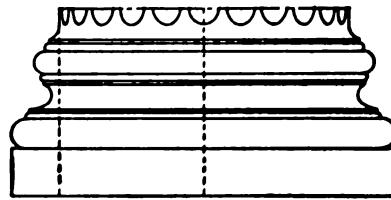

FIG. 79



Palladio's Corinthian Base

FIG. 80

**Fleuron.** From each *Bud* rise also two scrolls, or *Volutes*, one of which runs out to support the projecting corner of the *Abacus*. The other, which is smaller and does not rise higher than the *Lip* of the *Bell*, supports the *Fleuron*. Sixteen leaves of a third row curl over under these sixteen volutes, making with them eight masses of ornament, one on each corner of the column, and one in the middle of each side. These give in plan an eight-pointed star, each point consisting of a large leaf, two small leaves, two *Volutes*, and above them, either the *Fleuron* or the horn of the *Abacus*. Between them is seen the *Bell* of the *Cap*, with its *Lip*.

Here, again, the *Attic Base* is commonly used, but sometimes, especially in large columns, a base is used that resembles *Vignola's Ionic Base*, with two *Beads* between the

Scotias, except that it has a lower Torus, Fig. 78. Palladio used a very elegant variety of Attic Base, enriched by the addition of Beads and Fillets, Fig. 80. The Shaft is fluted like the Ionic shaft, with twenty-four semicircular flutings, but these are sometimes filled with a convex moulding, or *Cable*, to a third of their height, Fig. 75.

Almost all the buildings erected by the Romans employ the Corinthian Order.

TABLE OF THE CORINTHIAN ORDER—PLATES XIV,  
XV, AND XVI

$\frac{1}{4} D$ equals	{	height of Architrave. height of Frieze.
$1 D = \frac{1}{4} D$ equals	{	height of Cornice. projection of Cornice.
$\frac{1}{4} D$ equals	{	projection of Plinth. height of Plinth. height of Lower Band. height of Dentils. distance of Dentils, o. c.
$\frac{1}{2} D = \frac{2}{3} D$ equals	{	height of Leaves. projection of Abacus.
$\frac{1}{2} D = \frac{2}{3} D$ equals		length of Modillions.
$\frac{2}{3} D = \frac{1}{3} D$ equals	{	distance of Modillions, o. c. distance from Axis to face of Double Dentil.
$\frac{2}{3} D$ equals		upper Diameter.
$1 D = \frac{2}{3} D$ equals	{	lower Diameter. height of Bell. height of Cornice. projection of Cornice.
$\frac{2}{3} D$ equals	{	height of Capital. width of Abacus (least). width of Lip of the Bell.

- $1\frac{1}{3} D = \frac{8}{6} D$  equals width of Plinth.  
 $1\frac{1}{2} D = \frac{9}{6} D$  equals width of Abacus (greatest).  
 $2 D = \frac{12}{6} D$  equals width of Abacus (diagonal).  
 $\frac{1}{6} D$  equals width of Dentil.  
 $\frac{2}{6} D$  equals width of Modillion.  
 $\frac{1}{12} D$  equals width of Interdentil.  
 $\frac{1}{12} D$  equals  $\left\{ \begin{array}{l} \text{height of Astragal.} \\ \text{projection of Astragal.} \end{array} \right.$   
 $\frac{1}{6} D$  equals height of Modillion.

THE COMPOSITE ORDER—PLATES XII AND XIII

18. The Composite Order, Fig. 81, is a heavier Corinthian, just as the Tuscan is a simplified Doric. The chief proportions are the same as in the Corinthian Order, but the details are fewer and larger. It owes its name to the Capital, Fig. 82, in which the two lower rows of leaves and the Caulicoli are the same as in the Corinthian. But the Caulicoli carry only a stunted leaf-bud, and the upper row of leaves and the sixteen Volutes are replaced by the large Scrolls, Echinus, and Astragal of a complete Ionic Capital, with four faces like Scamozzi's. A Composite Capital thus has two Astragals, if the lower be included, but this properly belongs to the shaft. The Scrolls are nearly half a Diameter high, covering up half the Abacus and coming down so as to touch the second row of Acanthus leaves. They measure fully nine-sixths across, and are only three-sixths apart, or half a Diameter, instead of four-sixths, as in the Ionic.

Vignola's Composite Entablature, Fig. 82, differs from his Ionic chiefly in the shape and size of the Dentils. They are larger, and are more nearly square in elevation, being a fifth of a Diameter high, and one-sixth wide, the Interdentil being one-twelfth, and they are set one-fourth of a Diameter apart, on centers. The last Dentil, or first half of the Double Dentil, is centered over the outer face of the Column, at the



bottom, as in the Corinthian, Ionic, and Denticulated Doric, Fig. 95. The outer face of the Double Dentil is three-quarters of a Diameter from the axis of the Column, and

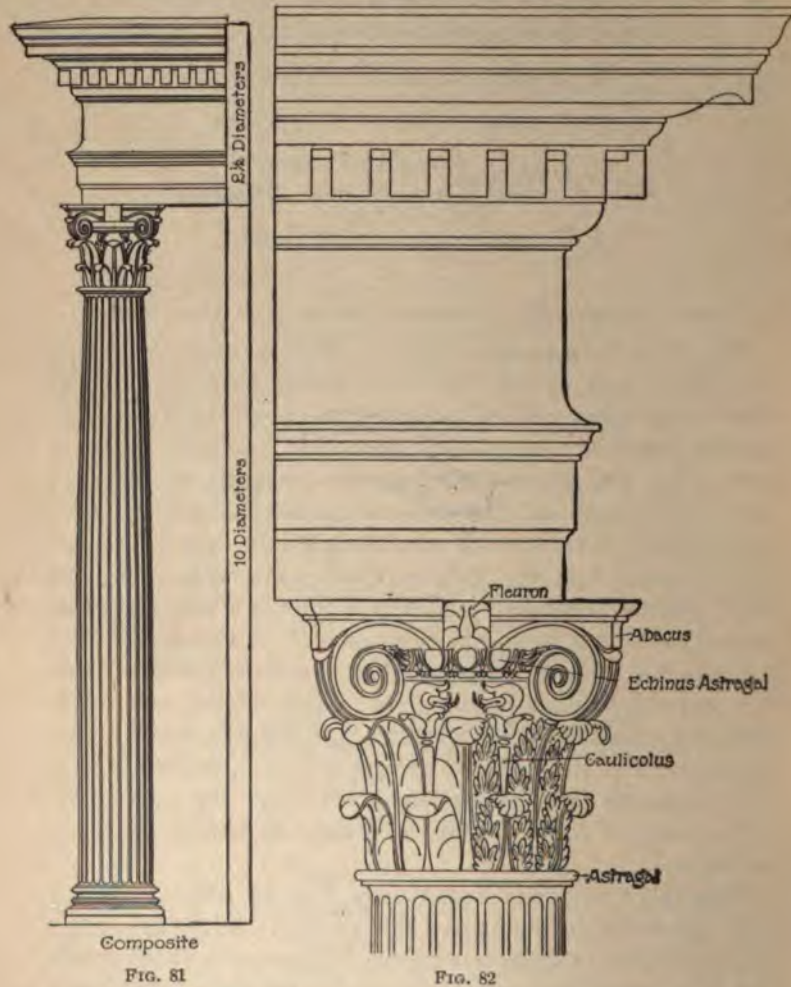

there is only one Dentil between the Double Dentil and the one over the axis, against two in the Corinthian and Ionic, and three in the Denticulated Doric. The Frieze terminates



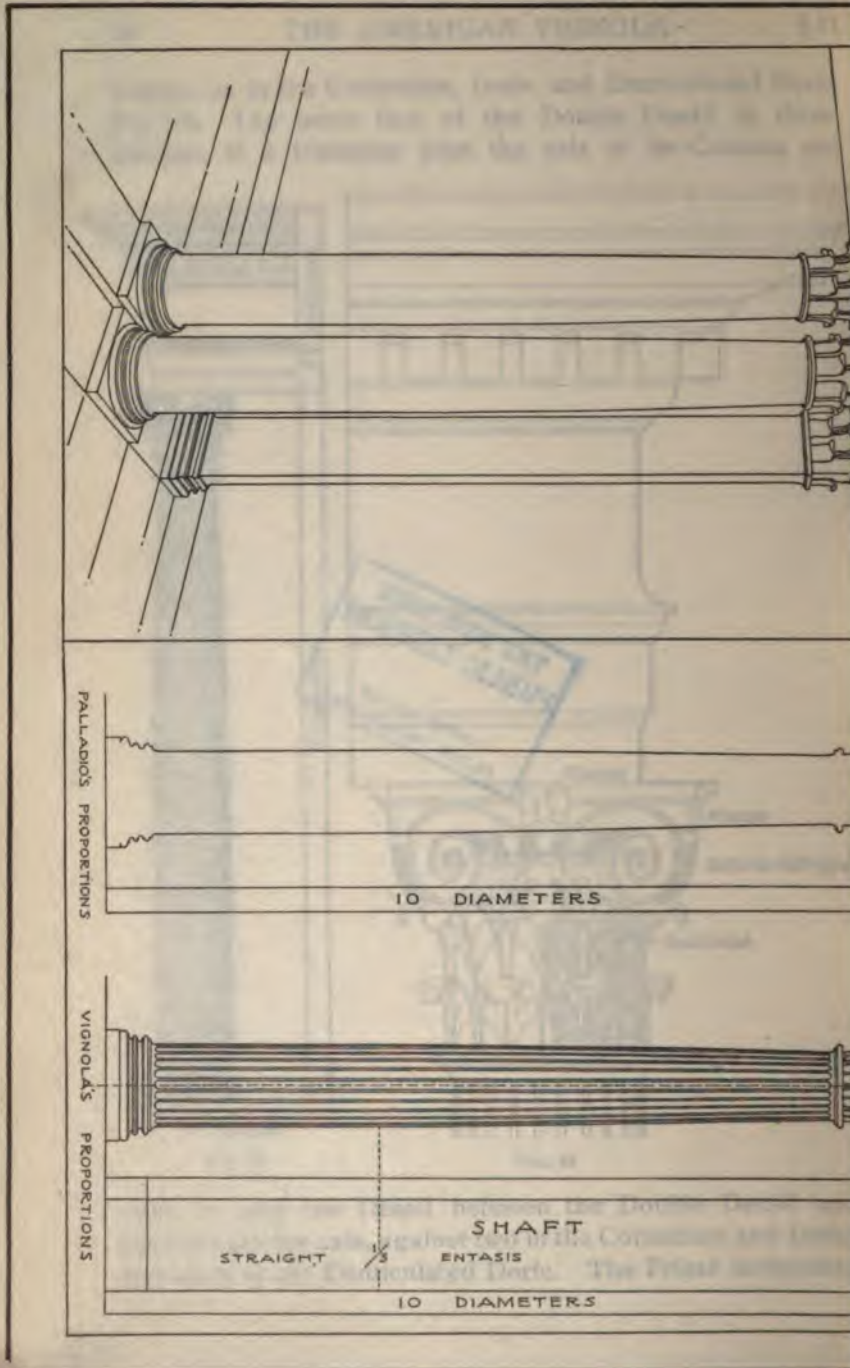

# COMPOSITE ORDER

AFTER VIGNOLA

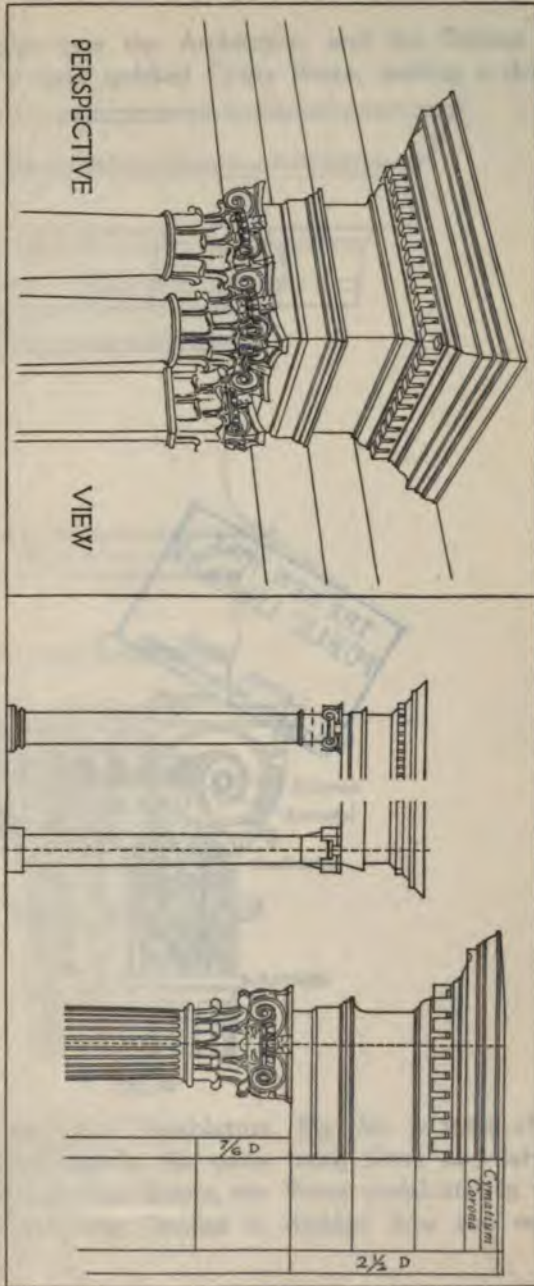

AFTER PALLADIO



LA



in a large Congé over the Architrave, and the Corona is undercut with a large quirked Cyma Recta, making a drip.

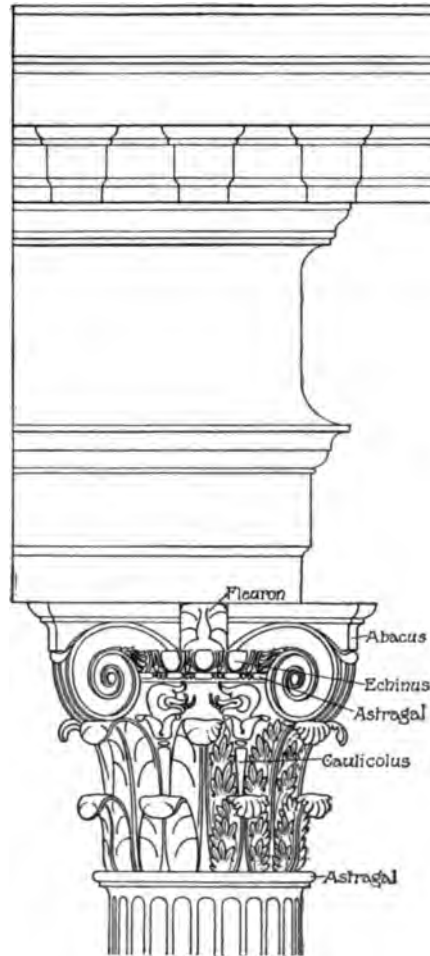

FIG. 83

Palladio's Composite Entablature, Fig. 83, is more characteristic than Vignola's, the parts being fewer and larger. The Architrave has two Bands, the Frieze terminates in two large Congés, and the Corona is divided into two equal

parts, each half a Diameter high. The upper half is shared about equally by the Cymatium and the Corona, and the lower half is almost entirely taken up by a series of large brackets, or blocks, a third of a Diameter high, and one-fourth wide, divided into two Bands. The inner face of the Double Block comes just in line with the Frieze below, Fig. 102. The bands and mouldings that decorate the Blocks are continued between them.

These dimensions apply to Palladio's entablature where it is made of the same size as Vignola's, that is to say, a quarter of the height of the column, or two Diameters and a half. But Palladio himself made his Composite entablature only two Diameters high, or one-fifth the length of the column, cutting down the Frieze to half a Diameter, the Architrave to two-thirds, and the Cornice to five-sixths. If the dimensions of Palladio's Cornice given in the table are, accordingly, taken from the upper diameter of the shaft instead of from the lower, they will exactly conform to Palladio's own usage.

The Block entablature used by Scamozzi for his Composite Order is even less than two Diameters in height, and this seems to have been the case also with the entablature of the Olympiæum at Athens, which Palladio is thought to have imitated.

The mouldings below the Blocks are often made to project more than in Palladio's example. This increases their distance apart, on centers, since one must still come over the axis of the column and the one on the corner must be as far out as the end of these mouldings. The Blocks also vary considerably in length in different examples.

The upper part of the Composite Capital, as has been said, is often used alone as a variety of the Ionic Capital.

The Composite Capital is employed in the Arch of Titus in Rome, and elsewhere, with a Corinthian entablature, and the Block Cornice occurs in the so-called frontispiece of Nero, as well as in the temple at Athens, in connection with a Corinthian Capital.

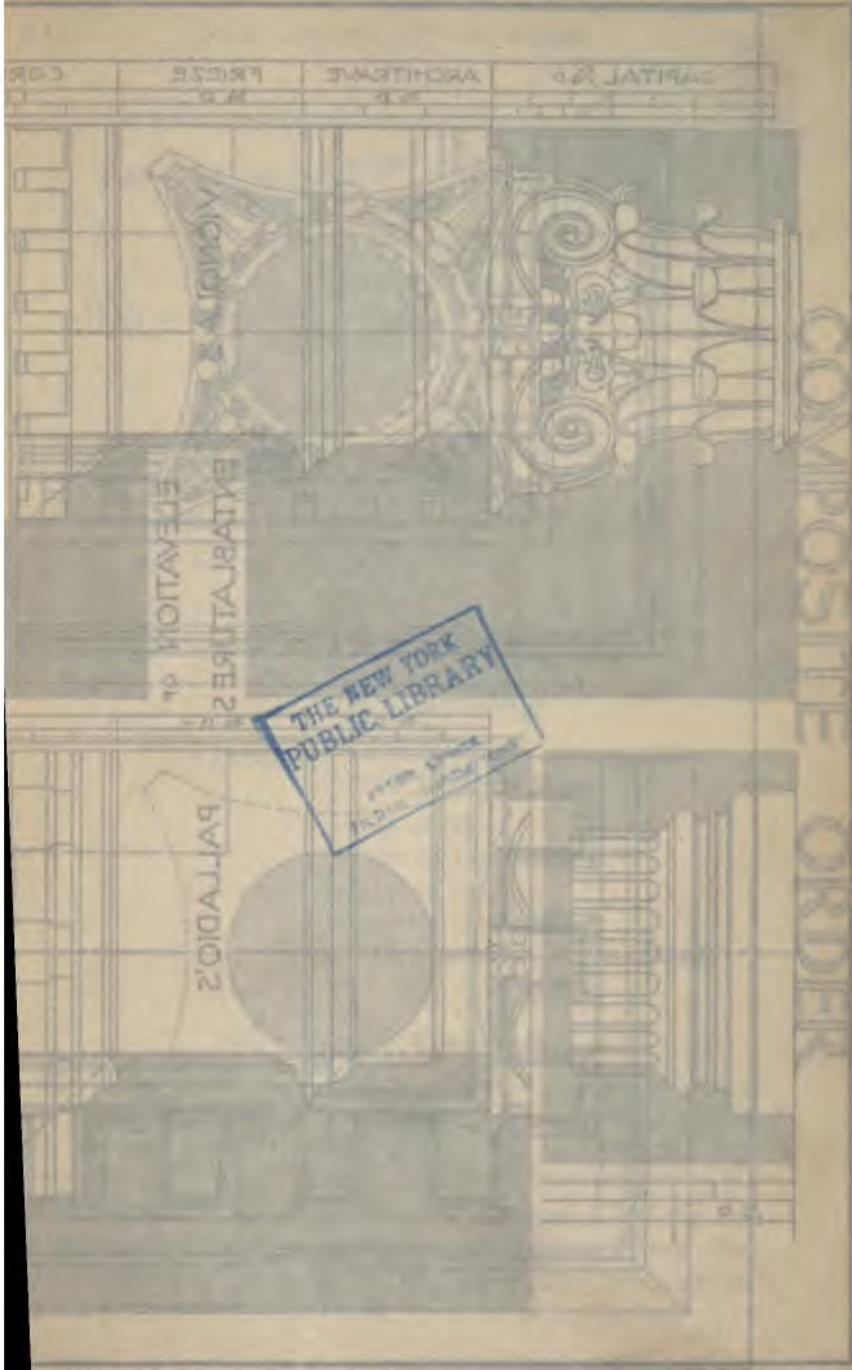

THE NEW YORK  
PUBLIC LIBRARY



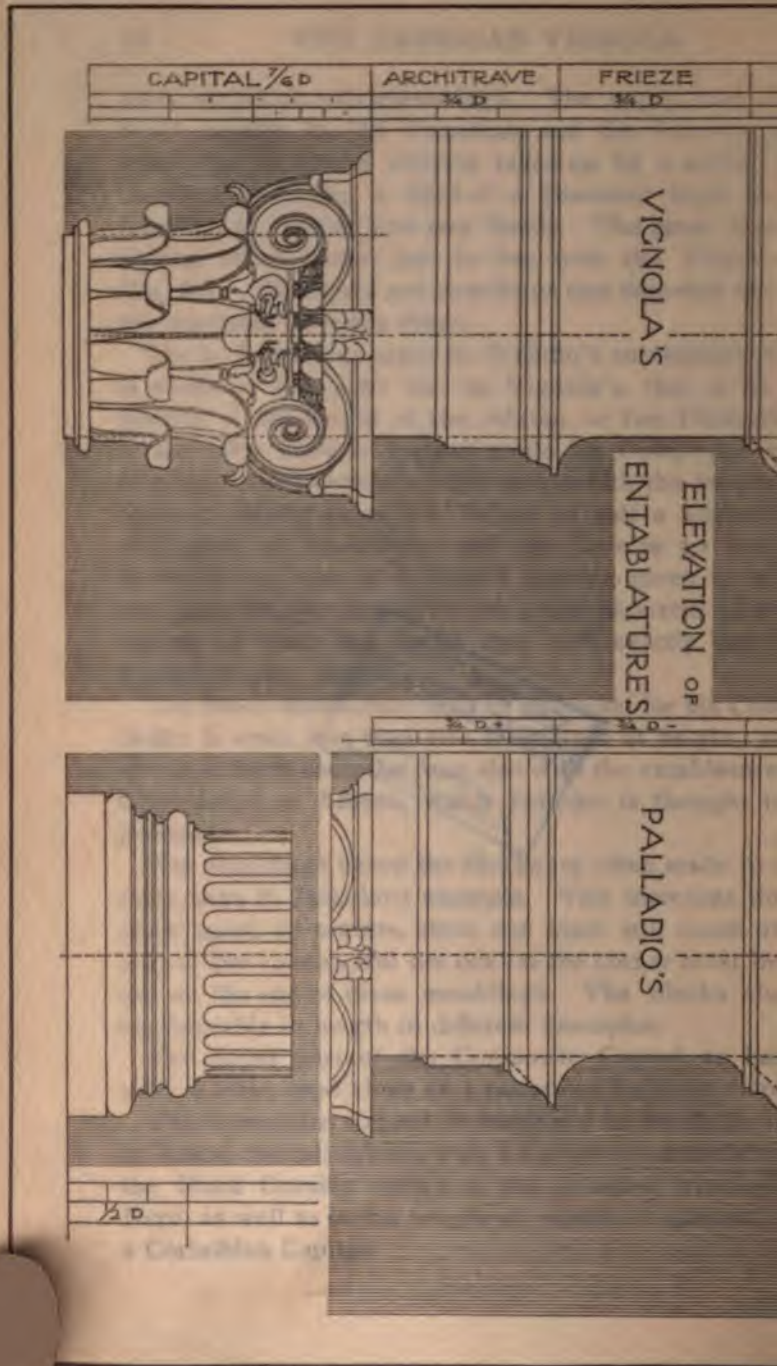

# COMPOSITE ORDER

PLAN OF ENTABLATURES LOOKING UP

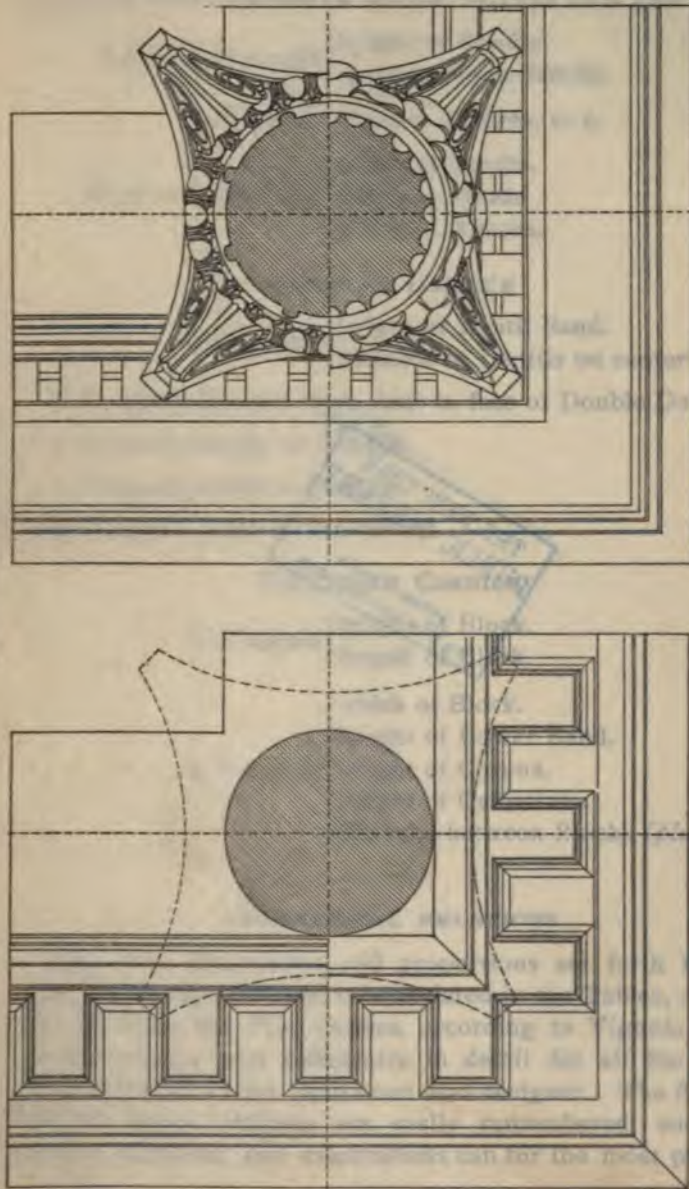

COMPOSITE ORDER

THE NEW YORK  
PUBLIC LIBRARY  
ASTOR LENOX  
TILDEN FOUNDATION

PALMERS



## TABLE OF THE COMPOSITE ORDER—PLATES XVII AND XVIII

$$\frac{1}{2} D = \frac{2}{3} D \text{ equals } \begin{cases} \text{height of Scrolls.} \\ \text{space between Scrolls.} \end{cases}$$

$$\frac{1}{3} D \text{ equals distance of Eyes, o. c.}$$

$$1\frac{1}{2} D = \frac{2}{3} D \text{ equals } \begin{cases} \text{width of Scrolls.} \\ \text{width of Plinth.} \\ \text{width of Abacus.} \end{cases}$$

## VIGNOLA'S CORNICE

$$\frac{1}{2} D \text{ equals } \begin{cases} \text{height of Dentil Band.} \\ \text{distance of Dentils on centers.} \end{cases}$$

$$\frac{1}{3} D \text{ equals distance from Axis to face of Double Dentil.}$$

$$\frac{1}{2} D \text{ equals height of Dentils.}$$

$$\frac{1}{2} D \text{ equals width of Dentils.}$$

$$\frac{1}{4} D \text{ equals width of Interdentil.}$$

## PALLADIO'S CORNICE

$$\frac{1}{2} D \text{ equals } \begin{cases} \text{height of Block.} \\ \text{length of Block.} \end{cases}$$

$$\frac{1}{2} D \text{ equals } \begin{cases} \text{width of Block.} \\ \text{height of Lower Band.} \\ \text{height of Corona.} \\ \text{height of Cymatium.} \\ \text{distance between Blocks (plus).} \end{cases}$$

## GEOMETRICAL RELATIONS

19. The dimensions and proportions set forth in the previous paragraphs, and recapitulated in the Tables, enable one to draw the Five Orders, according to Vignola, with great accuracy and sufficiently in detail for all the ordinary purposes of the draftsman and designer. The figures for the larger features are easily remembered, and the smaller divisions and subdivisions can for the most part be

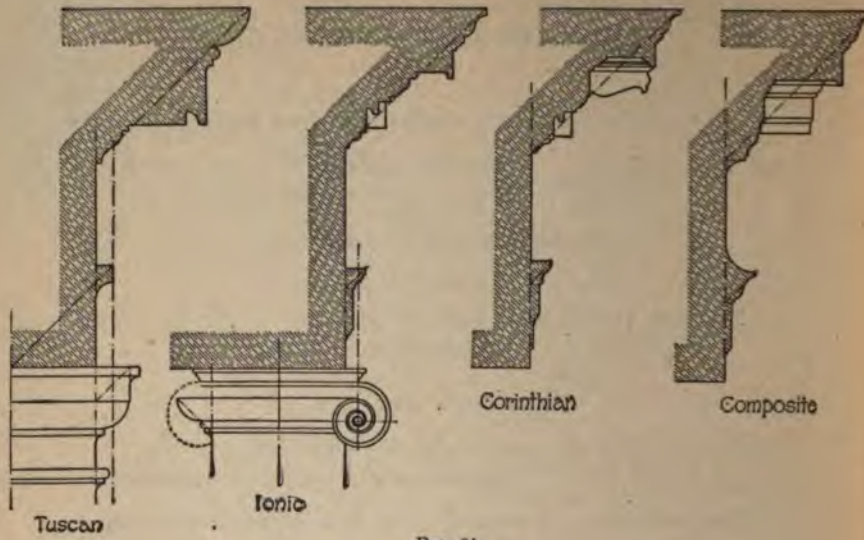

FIG. 84

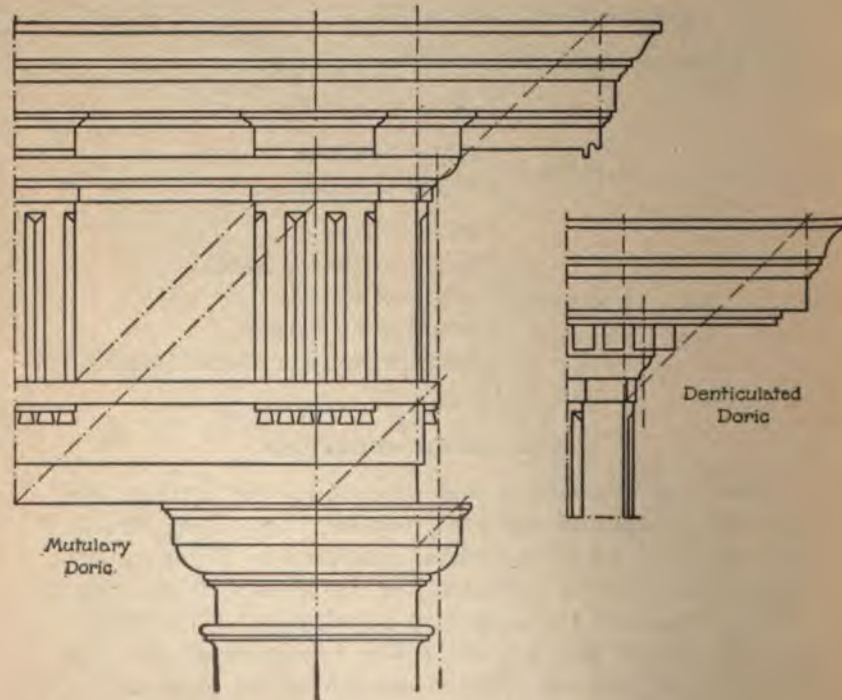

FIG. 85

obtained by dividing the larger into two, three, four, or five equal parts.

But besides these arithmetical proportions some geometrical relations may be pointed out, which are calculated greatly to facilitate the work of draftsmanship, drawing being naturally more closely related to Geometry than to Arithmetic.

**20. Lines at 45 Degrees.**—The proportions of any figure that is as wide as it is high, and which can accordingly be included within a square, are most easily determined by drawing the diagonal of the square, that is to say, by drawing a line with a 45-degree triangle. Such figures are, as is shown in the Illustrations, the projections of:

1. The Echinus, in the Tuscan, Doric, and Ionic Capitals, Figs. 84 and 85.

2. The Abacus, in the Tuscan and Doric Capitals, Figs. 84 and 85.

3. The Astragal, in all the Orders, Fig. 86.

4. The Architrave, including the Tænia, in the Tuscan and Doric Orders, counting from the axis of the Column, Figs. 84 and 85.

5. The Tænia itself, and the Cymatium that takes its place, Figs. 84 and 85.

6. All the Cornices, except the Doric, Fig. 84.

A line drawn at 45 degrees through the Doric Cornice from the top of the Frieze gives, where it cuts the upper line of the Cornice:

1. The face of the Corona, in the Denticulated Doric, Fig. 85.

2. The face of the Mutule in the Mutulary Doric, Fig. 85.

A line drawn at 45 degrees through the Doric Architrave and Frieze, from a point on the axis of the Column and of the Triglyph, taken either at the bottom of the Architrave or at the top of the Frieze, gives the axis of the next Triglyph, and so on, Fig. 85.

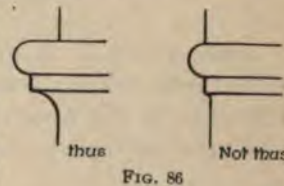

FIG. 86

A 45-degree line also gives:

1. The Shape of the Metope, Fig. 85.
2. The Caps of the Pedestals, except the Tuscan, Fig. 87.
3. The Plinths of the Doric and Attic Bases, Fig. 87.

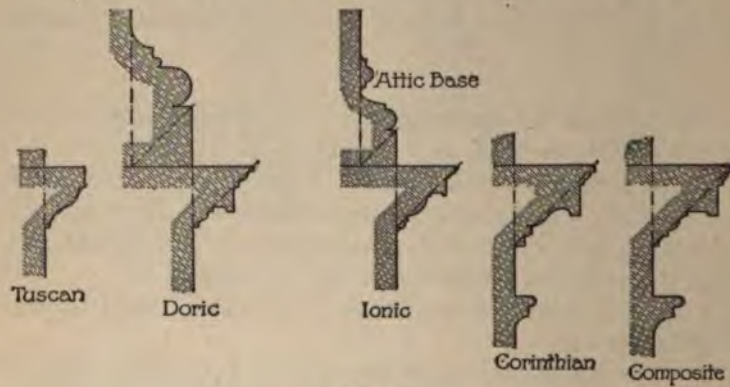
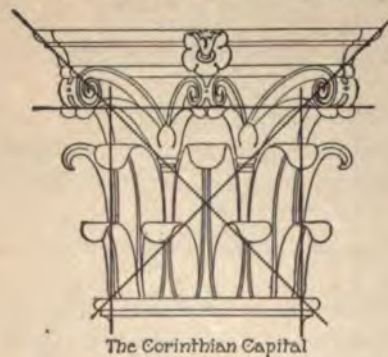

FIG. 87

Lines drawn at an angle of 45 degrees across the Corinthian Capital from the extremities of its lower diameter give the width of the Abacus, Fig. 88.

Where they cut the line of the upper diameter of the shaft, extended, they give the depth of the Scroll, Fig. 88.



The Corinthian Capital  
FIG. 88

**21. Lines at 60 Degrees.**—In like manner, lines drawn at an angle of 60 degrees through the Bed Mould of the Ionic Cornice from a point on the axis of the Column, taken either on the upper line of the Frieze or on the upper edge of the Dentil

Band, give, where they touch the upper line of the Frieze and the upper line of the Dentil Band, the Axes of the Dentils, and the outer face of the Double Dentil, Fig. 89.

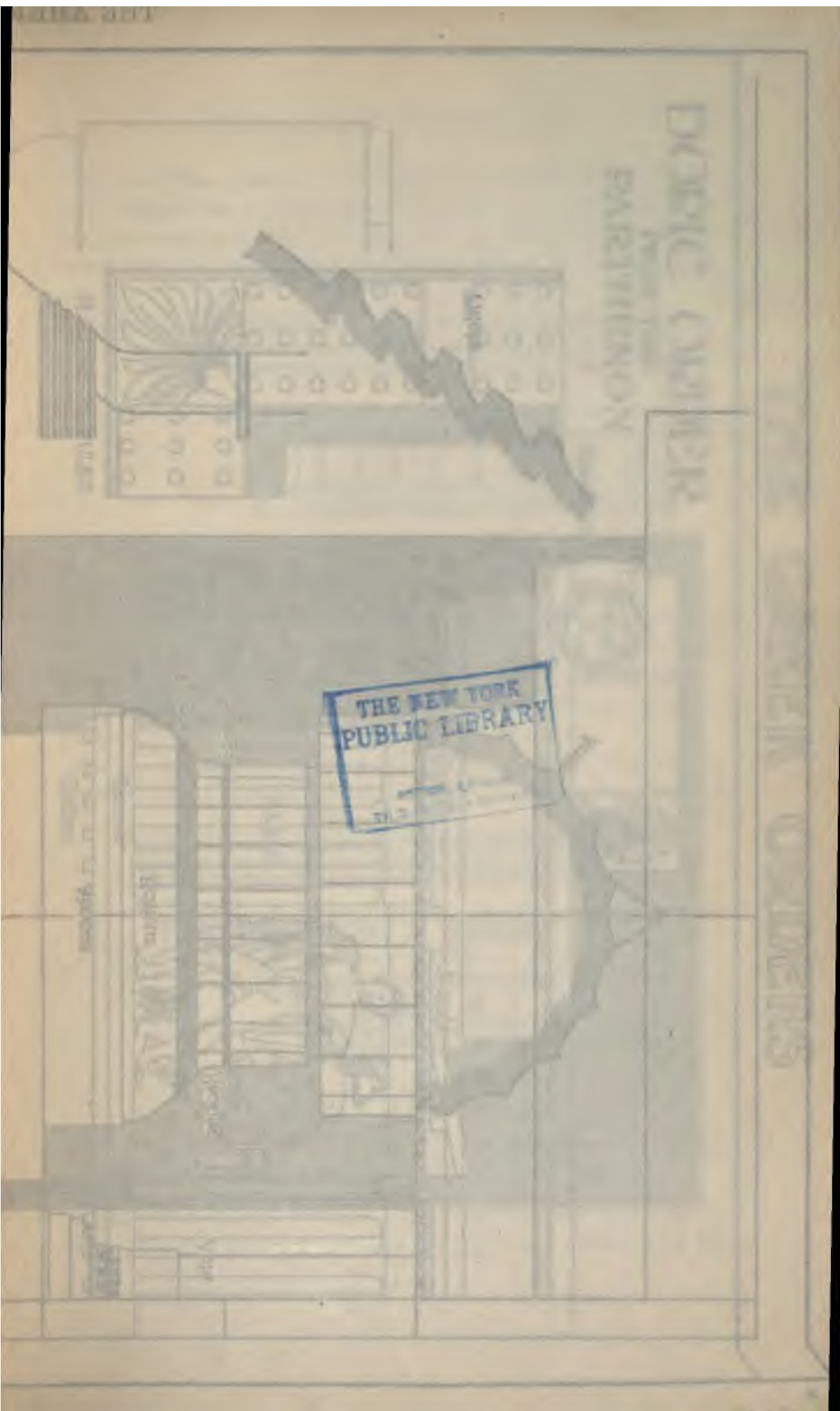

DOMIC CHAMBER  
PARTITION

THE NEW YORK PUBLIC LIBRARY

THE NEW YORK  
PUBLIC LIBRARY

100 000



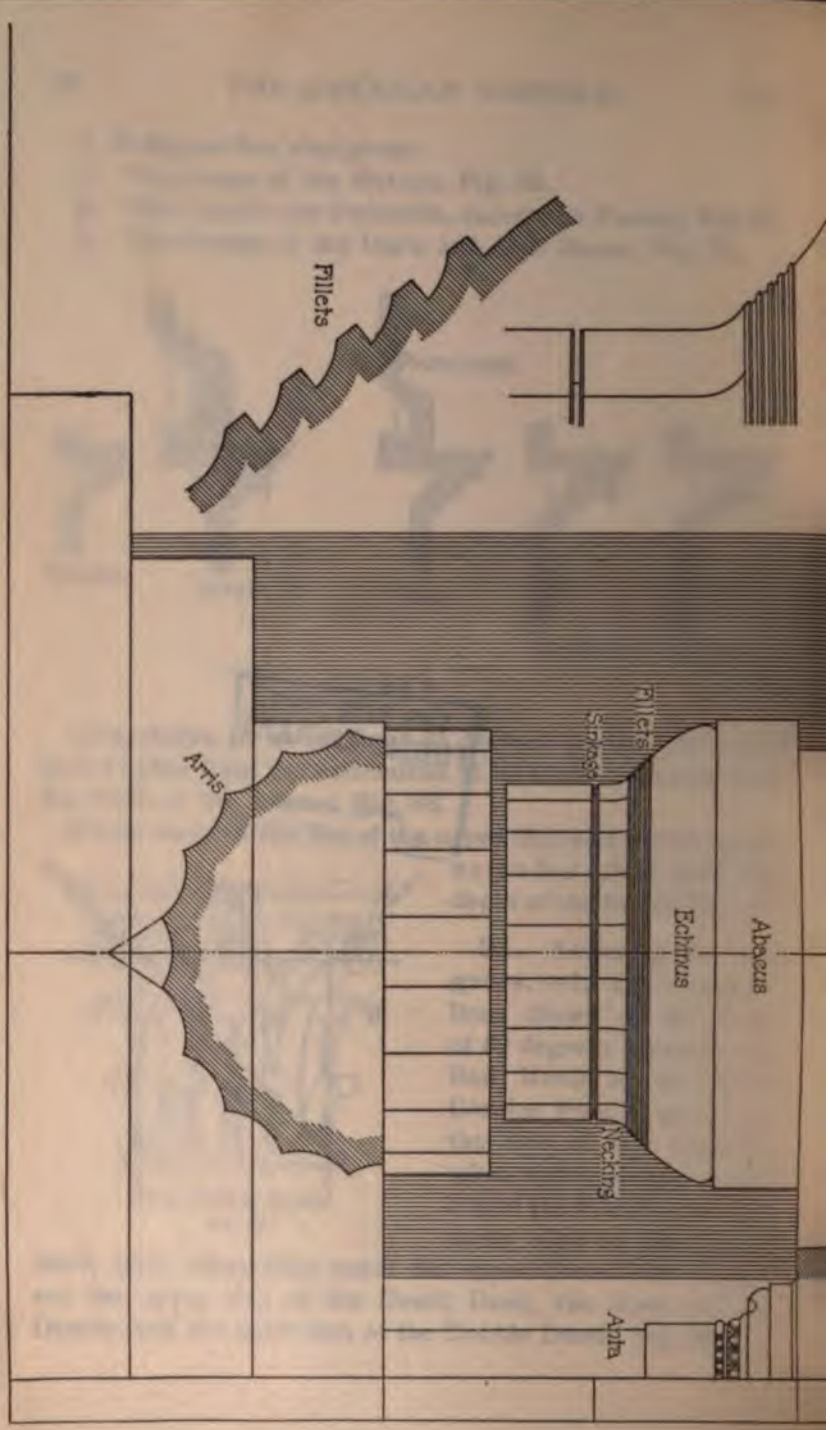

# THE GREEK ORDERS

## DORIC ORDER FROM THE PARTHENON

Gymnasium

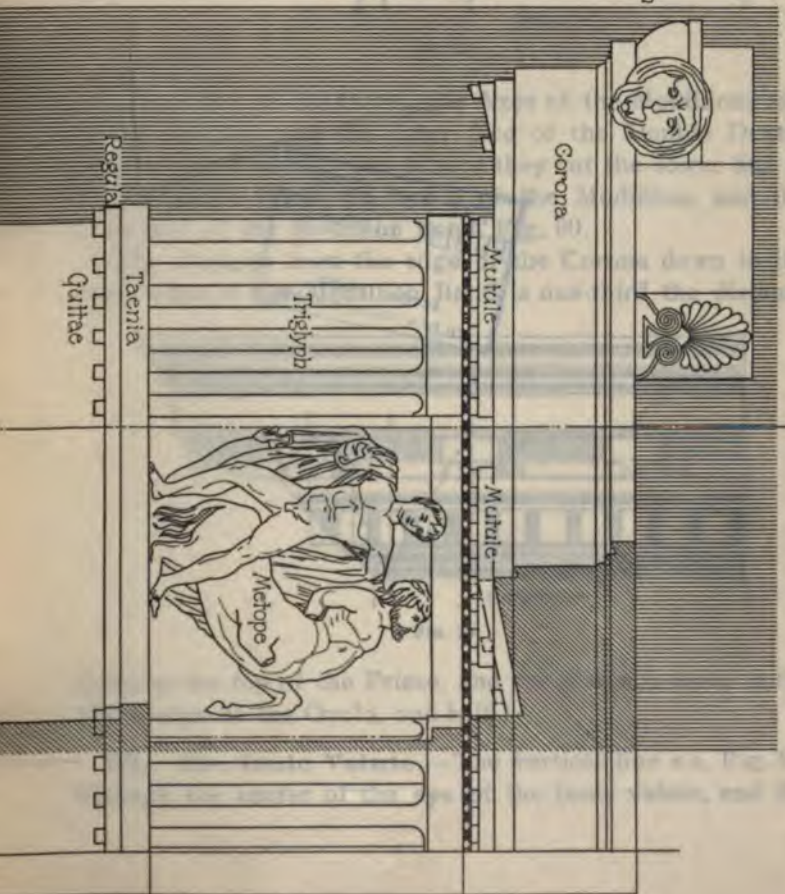
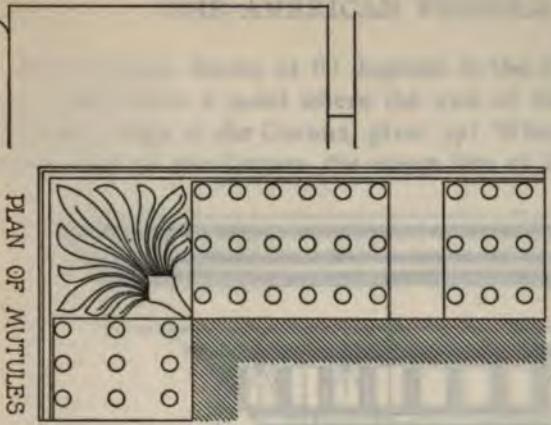



Similar lines drawn at 60 degrees in the Corinthian Cornice, taken from a point where the axis of the Column cuts the lower edge of the Corona, give: (*a*) Where they cut the lower edge of the Corona, the upper line of the Frieze, and

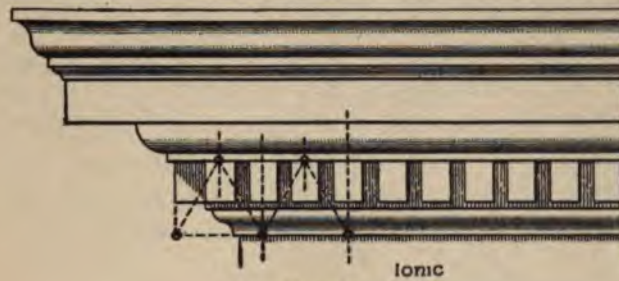

FIG. 89

the lower line of the Ovolo, the Axes of the Modillions and of the Dentils, and the outer face of the Double Dentil, very nearly, Fig. 90. (*b*) Where they cut the lower line of the Modillion Band, the width of the Modillion, and the outer face of the Modillion Band, Fig. 90.

(The distance from the edge of the Corona down to the lower edge of the Modillion Band is one-third the distance

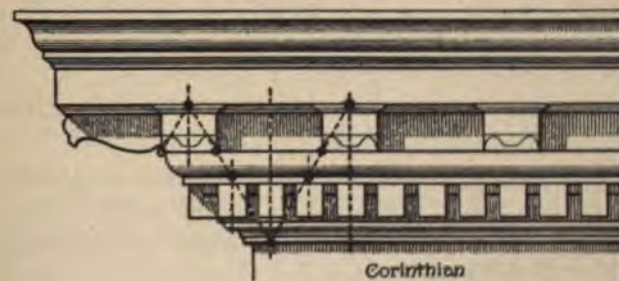

FIG. 90

down to the top of the Frieze, and the distance down to the lower edge of the Ovolo, one-half.)

**22. The Ionic Volute.**—The vertical line *ab*, Fig. 91, through the center of the eye of the Ionic volute, and the

horizontal line  $cd$ , will mark in the circumference of the eye the four corners of a square within which a fret may be drawn whose angles will serve as centers, from which the curves of the volute may be described mechanically. The sides of the square above referred to should be bisected, and through the upper points thus located a horizontal line  $ef$  should be drawn. Now, with  $eg$  as a radius, the arc  $gf$  may be drawn as the first section of the volute. Now, through the point  $h$ , where the line  $ef$  bisects the

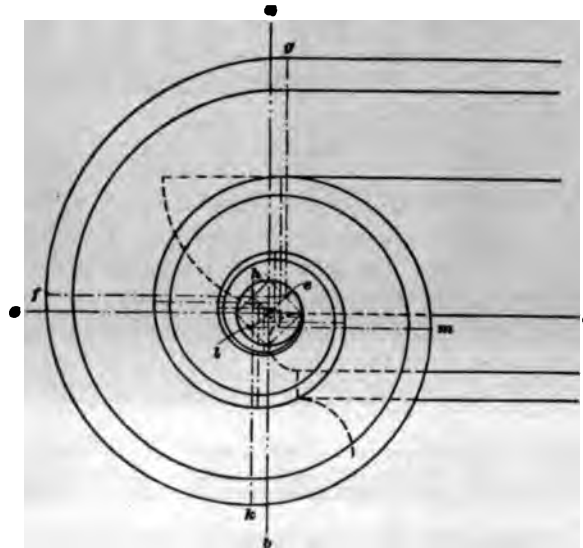

FIG. 91

side of the square, a vertical line  $hk$  should be drawn, and with  $hf$  as a radius the arc  $fk$  may be struck. From  $h$  and  $e$  lines should be drawn at 45 degrees, intersecting at the center of the eye, and the line extending from  $h$  to the center should be divided into three equal parts, through which the corners of the inscribed fret will turn. The point  $l$  on the line  $hk$ , marking the lower left-hand corner of the inscribed fret, is located  $\frac{2}{3}$  of the distance between  $h$  and the point where  $hk$  bisects the lower side of the square.  $l$  then forms the center for the arc  $km$ , and the rest of

the volute is described from centers found at the angles of the inscribed fret.

**23. Vertical Lines.**—The outer line of the upper Diameter of the Shaft gives, in all the Orders, Figs. 84 and 85, the face of the lower band of the Architrave, and the face of the Frieze.

In the Denticulated Doric, it gives, Fig. 85, the outer face of the first Dentil, next the Double Dentil.

In the Ionic and Corinthian Orders, it gives the axis of the first Interdentil.

The outer line of the lower Diameter of the Shaft, produced upwards, gives, Figs. 84 and 85:

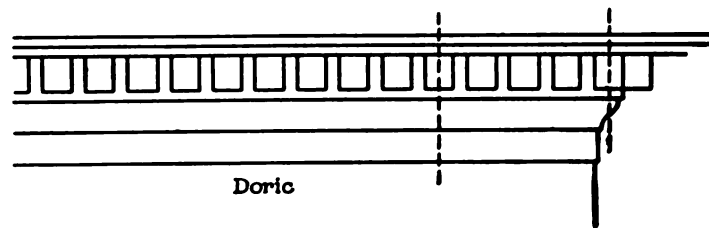

FIG. 92

1. The projection of the Astragal, in all the Orders, except the Tuscan and Doric.

2. The projection of the Tænia, in the Tuscan and Doric.

3. The projection of the Fillet, in the Bed Mould of the Mutulary Doric, Fig. 85.

4. Twice the projection of the Triglyph, which is seen in profile.

5. Half the projection of the Tuscan Bed Mould, of the Tuscan and Doric Abacus, and of the Doric Mutule Band.

It also gives the Axis of the Extreme Dentil, or first half of the Double Dentil, in the Denticulated Doric, Ionic, Corinthian, and Composite Orders, Figs. 92, 93, 94, and 95, and the position of the Eye of the Ionic Scroll, which is on a level with the bottom of the Echinus, Fig. 91.

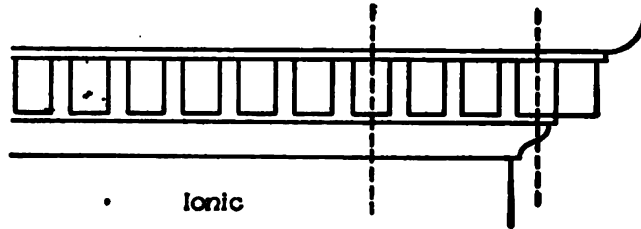

Ionic

FIG. 93

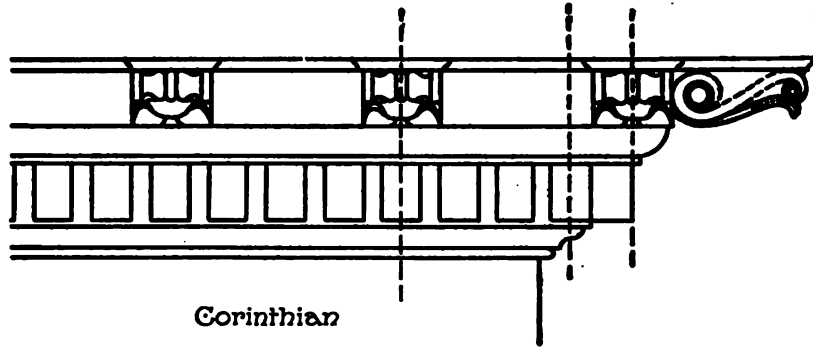

Corinthian

FIG. 94

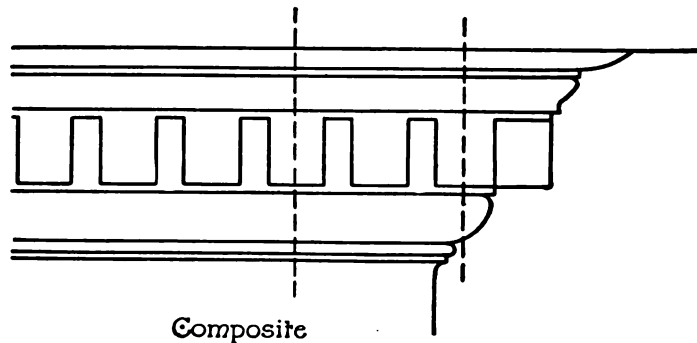

Composite

FIG. 95

## DRAWING

**24. General Proportions.**—Since the relative size of all the parts, in Vignola's Orders, is fixed, any of them can be drawn out in accordance with these rules, if a single dimension is determined. The width of a Dentil or the length of a Modillion suffices to determine everything else. But the data generally given are either the lower Diameter of a Column, the height of a Column, or the whole height of the Order, with or without a Pedestal.

I. If the lower Diameter is given, the procedure is as follows, Fig. 96: Divide it in two, draw the axis of the Column, and then divide each half into three equal parts, Fig. 109; this gives the scale of sixths. Divide in two the two outer sixths; this gives the upper Diameter of the shaft, which is five-sixths. Lay off on the axis the height of the Column—by Diameters, 7, 8, 9, or 10—and of the Entablature, which is one-fourth the height of the Column. Mark the height of the Base, half a Diameter, or three-sixths, and then that of the Capital, two-, three-, or seven-sixths.

Then divide the total height of the Entablature into seven, eight, eighteen, or ten equal parts, according as it is Tuscan, Doric, Ionic, or Corinthian, or use halves, quarters, or eighths of a Diameter, and mark the heights of the Architrave, Frieze, and Cornice, drawing horizontal lines through the points of division. (Fig. 96 illustrates this procedure for the Tuscan Order.) Then carry up, vertically, the outer lines of both the upper and the lower Diameters of the Shaft, drawing from the point where the line of the upper Diameter cuts the lower edge of the Cornice a line at 45 degrees to determine the projection of the Cymatium, or that of the Mutule or of the Corona.

Add one-third of the height of the Column for the Pedestal. Divide this into three equal parts, taking the upper third of the upper third for the Cap, and the lower two-thirds of the lower third for the Base. Vignola makes the Base of the Pedestal only one-ninth of the height of the Pedestal instead of two-ninths as here determined.



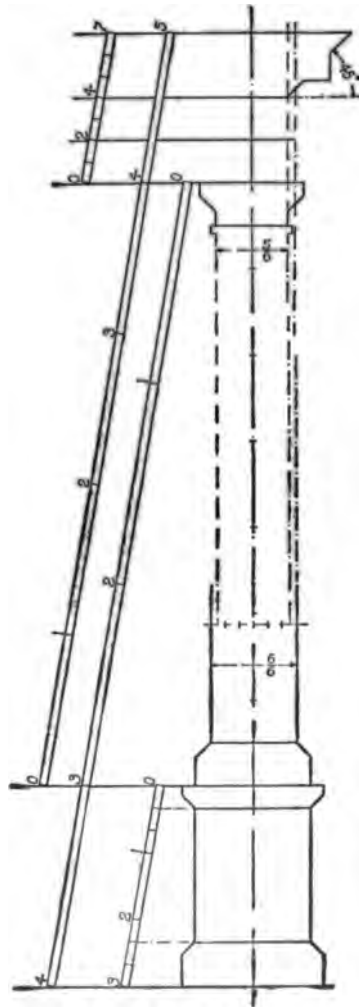

FIG. 96

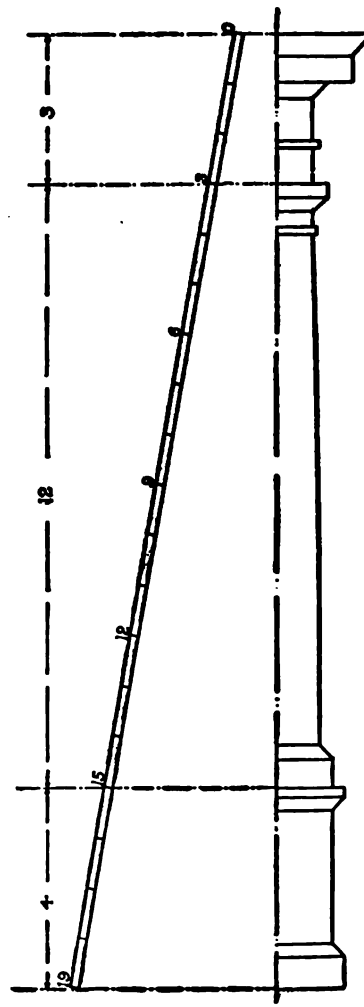

FIG. 97

II. If the height of the Column is given, a fourth part of this added at the top gives the height of the Entablature, and a third part added below gives the height of the Pedestal, Fig. 96. One seventh, eighth, ninth, or tenth of the height of the column gives the lower Diameter of the Shaft. The drawing may then be carried forwards as above.

III. If the total height of the Order is given, without the Pedestal, a division into five equal parts gives four parts for the Column and one for the Entablature, Fig. 96.

If there is a Pedestal, and it is of the regular height of one-third the height of the Column, the division of the total height must be into nineteen equal parts, four of which go to the Pedestal, twelve to the Column, and three to the Entablature, Fig. 97.

The lower Diameter can then be obtained from the height of the Column, and the drawing completed, as above.

NOTE.—The division of a given dimension into equal parts may be effected with the dividers, or, more easily, by using a scale of equal parts that are the same in number as the desired subdivisions, but a little larger, and holding this scale obliquely between the extreme limits of the space to be divided, Figs. 96 and 97. The division of vertical dimensions into five, seven, eight, nine, ten, eighteen, or nineteen equal parts, as here required, is thus easily accomplished. To insure accuracy, the lines marking these divisions should be horizontal, not normal to the direction of the scale.

**25. Cornices.**—The Tuscan Cornice may be drawn by dividing its height into quarters, as is done in the figure, giving the upper quarter to the Ovolo and the lower to the bed mould, and the middle half to the Corona, Bead, and Fillet, Fig. 98. A 45-degree line gives the projection of the Bed Mould, Ovolo, and the Cornice itself.

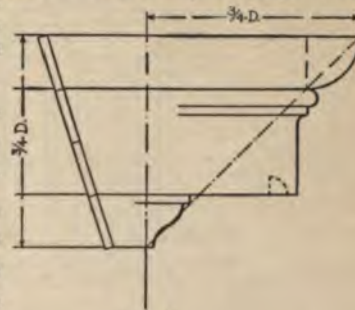

FIG. 98

The Doric Cornice is also divided in four equal parts, the upper one comprising the Cymatium and Fillet, the next the Corona and the small Cyma Reversa above it, the third the Mutules (or the Dentils with the Mutules above them),

...er one the Bed Mould, including the cap of the  
h, which is narrower in the Mutulary Doric than  
in the Denticulated by the  
width of the Fillet above  
it, Figs. 99 and 100.

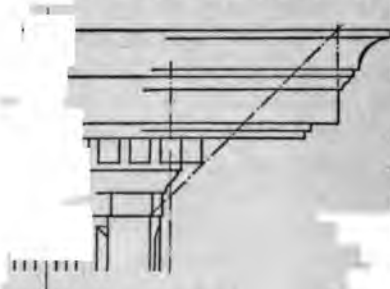

FIG. 99

eze. res the axes of  
are drawn next.  
and tæniæ, then the Mut

A 45-degree line drawn  
outwards from the middle  
of the top of the Abacus  
gives, where it cuts the  
lower line of the Frieze, the  
projection of the Tænia.  
A similar line, where it  
cuts the upper line of the  
Triglyph, Fig. 85. The  
their Cap, and the Regula  
e Dentils.

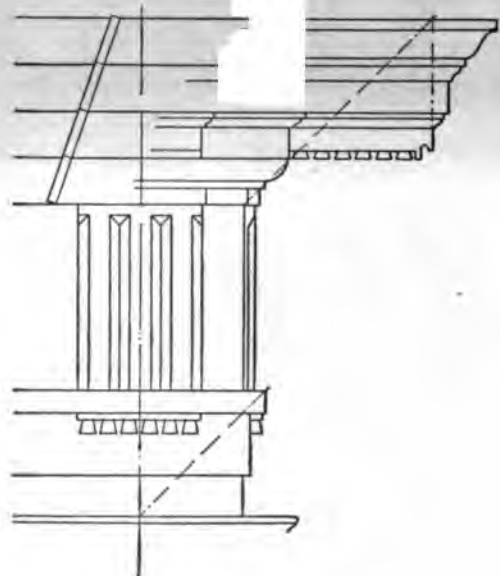

FIG. 100

In the Doric Order a line at 45 degrees drawn from the  
bottom of the Cornice gives the face of the Corona in the

Denticulated Doric, the face of the Mutule in the Mutulary; in the other Orders, a similar line gives the projection of the Cymatium, Figs. 99 and 100.

In putting in Dentils, draw first the one over the Axis of the Column, then the Double Dentil, the first half of which is centered over the lower face of the Column, and then the intermediate ones, three, two or one, according as the Order is Doric, Ionic, Corinthian, or Composite, Figs. 92, 93, 94, and 95. The Interdentil is half the width of the Dentil, except in the Composite.

One Corinthian Modillion comes over the axis of the corner column and one over the outer face of the Double

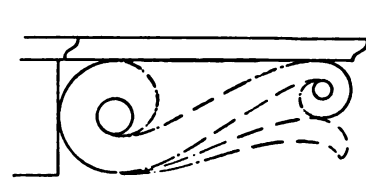
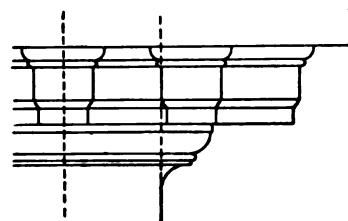

FIG. 101

Dentil, Fig. 94. In drawing the side of a Modillion, put in first, at the outer end, a semicircle half its height and one at the inner end nearly the whole height; then the rosettes, one twice as large as the other; then the connecting curves, and finally the leaf beneath, Fig. 101.



Composite

FIG. 102

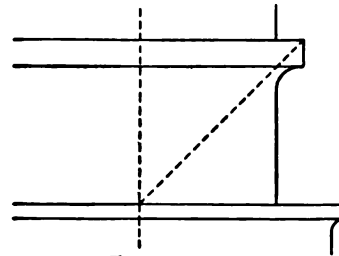

Tuscan

FIG. 103

In Palladio's Composite Cornice, one block is set over the axis of the column, and the double block at the corner has its inner face on a line with the face of the Frieze below. The blocks are about half a Diameter o. c., the interblock being one-twenty-fourth of a Diameter wider than the block itself, Fig. 102.

**26. Architraves.**—The Tuscan Architrave, Fig. 103, has but one fascia or band, the Composite two, Fig. 107, and

the Corinthian three, Fig. 106. The Doric has sometimes one, but generally two, Fig. 104, and the Ionic has generally two, Fig. 105, but sometimes three. The lower band is always the narrowest and is set on a line with the face of the shaft below and of the Frieze above.

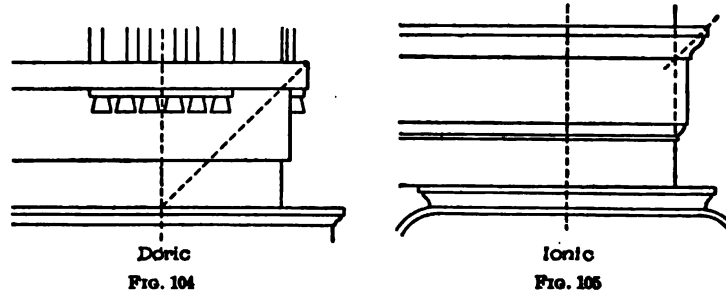

All the Architraves have a Cymatium, or crowning member, which in the Tuscan and Doric is a broad Fillet, called the Tænia, and in the Ionic and Corinthian is a large Cyma Reversa, surmounted by a Fillet and generally supported by a bead. The lower bands often have, as a Cymatium, a small Cyma Reversa, Bead, or Ovolo, and all three bands are sometimes sloped backwards, as in the Entablature of the

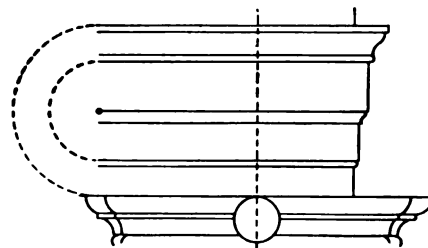

Corinthian  
FIG. 106

porch of the Pantheon in Rome, Fig. 108, so as to diminish the projection of the crowning mouldings, which generally have a projection, beyond the face of the Frieze, equal to their height.

The Tuscan Tænia has beneath it the characteristic Tuscan congé, Fig. 103. Beneath the Doric Tænia, and directly under each Triglyph, Fig. 104, is a narrow Fillet, which sometimes has a beveled face, called the Regula, beneath which are the six Guttæ. These are sometimes frustra of cones, as in the Greek Order, sometimes of

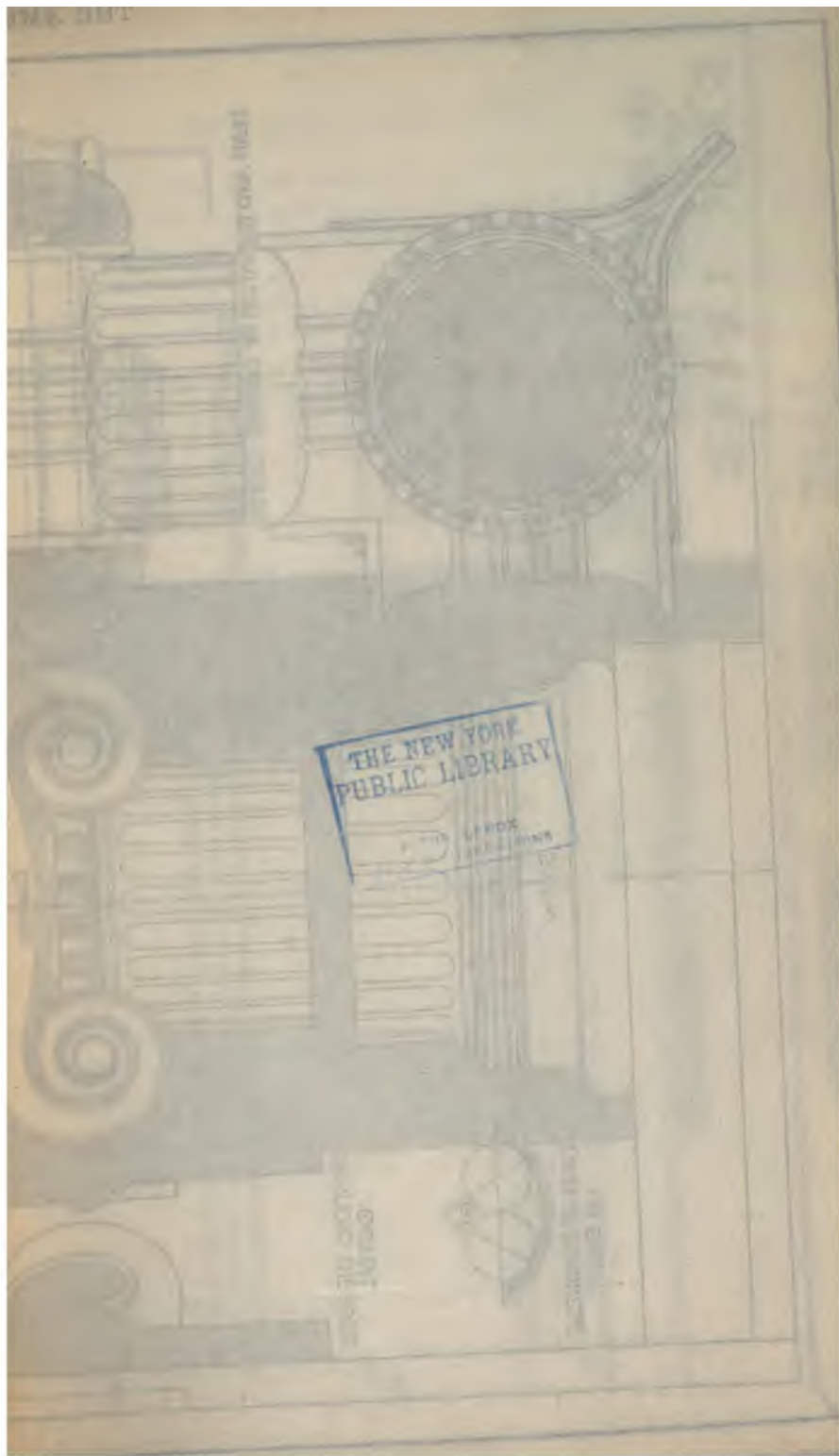

THE NEW YORK  
PUBLIC LIBRARY  
ASTOR  
LENOX  
TILDEN  
FOUNDATION

PLAN AND ELEVATION OF CORNER CAPITAL

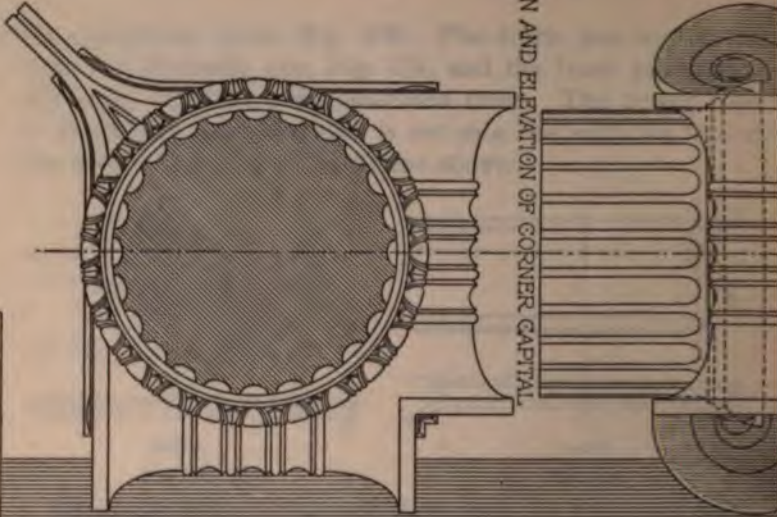

SECTIONS THROUGH CAPITAL

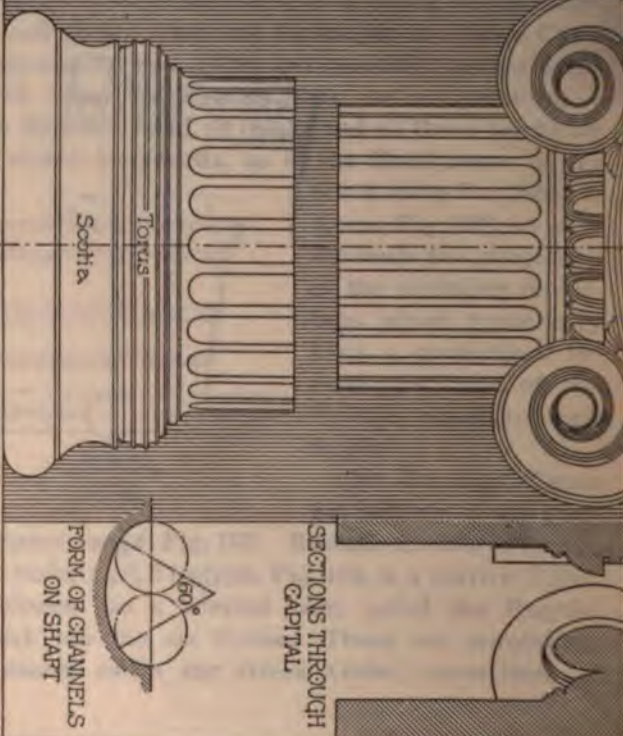

FORM OF CHANNELS ON SHAFT

# IONIC ORDER FROM THE TEMPLE ON THE ILLISSUS

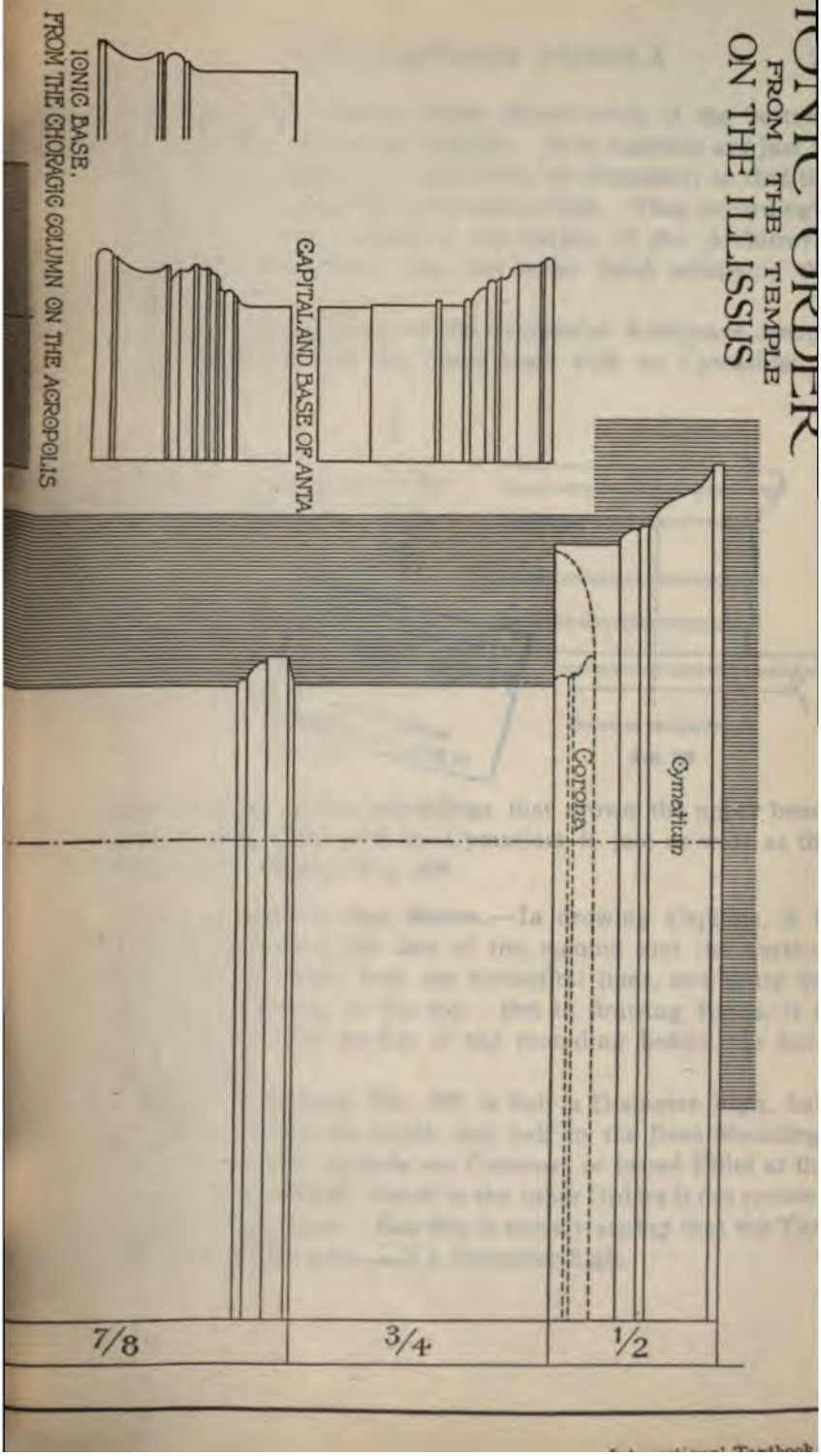

IONIC BASE,  
FROM THE CHORAGIC COLUMN ON THE ACROPOLIS

CAPITAL AND BASE OF ANTA

7/8

3/4

1/2





pyramids. The Guttæ, which almost touch at the bottom, are twice as high as the Regula. Both together are just as high as the Tænia, or one-twelfth of Diameter, so that the three are one-sixth of a Diameter high. They accordingly occupy the upper third of the height of the Architrave, which is three-sixths high, the lower band occupying the lower third.

The two lower bands of the Corinthian Architrave occupy half its height, and the lower band with its Cymatium is

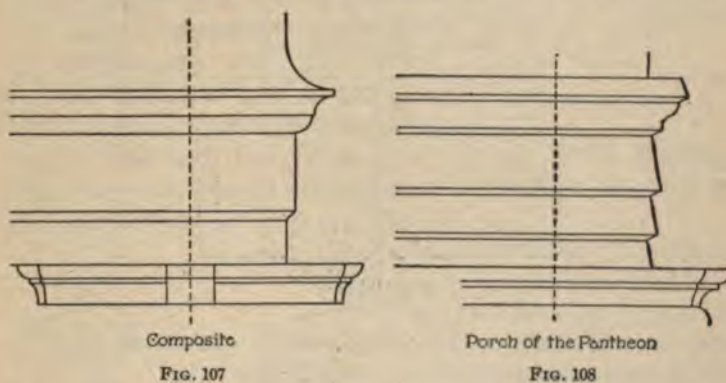

just as wide as the mouldings that crown the upper band. The second band with its Cymatium is just as wide as the third band without, Fig. 106.

**27. Capitals and Bases.**—In drawing Capitals, it is best to put in first the axis of the column and the vertical faces of the Shaft; then the horizontal lines, and lastly the profile, beginning at the top. But in drawing Bases, it is best to put in the profile of the moulding before the horizontal lines.

The Tuscan Base, Fig. 109, is half a Diameter high, half of which goes to the Plinth and half to the Base Moulding, which is made to include the Cincture, or broad Fillet at the bottom of the Shaft, which in the other Orders is not counted as part of the Base. But this is merely saying that the Tuscan Base is not quite half a Diameter high.

All the other Bases, including the Attic Base, are just half a Diameter high. All the Plinths are eight-sixths wide and one-sixth high, except the Tuscan and Doric, which are

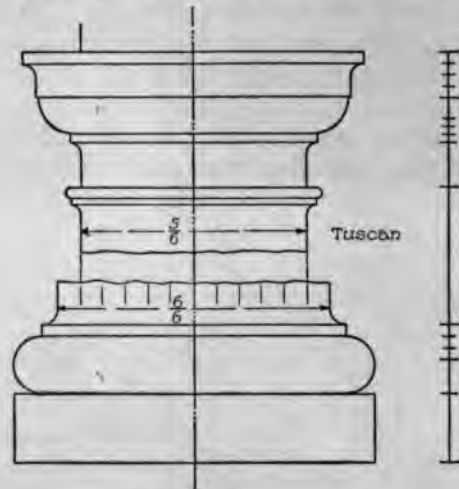

FIG. 109

one-quarter of a Diameter high. It is not worth while to define the proportions of the other Bases.

The Tuscan Capital, Fig. 109, is half a Diameter high, or three-sixths, the upper sixth comprising the Abacus with its Fillet, the middle sixth the Echinus and the Fillet below it, and the lower sixth the Necking. The upper Fillet is a

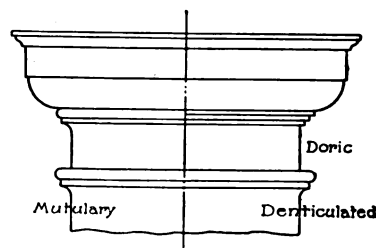

FIG. 110

quarter of a sixth wide, the lower one a sixth of a sixth. The Abacus is seven-sixths wide; i. e., it projects one-sixth on each side beyond the upper diameter of the Shaft.

The Doric Capital, Fig. 110, is also three-sixths of a Diameter high, the two upper sixths being divided into thirds, and these again into thirds, to give the height of the smaller mouldings. The Denticulated Capital generally has three Fillets, the Mutulary, a Bead and Fillet.

The Astragal, which in the other Capitals is one-twelfth of a Diameter high, or half a sixth, is in the Tuscan and Doric Orders one-fourth smaller, or one-sixteenth of a Diameter, the Bead being one-twenty-fourth of a Diameter high, or a quarter of a sixth. In drawing the Astragals, draw first the horizontal line at the top, which occupies two-thirds of the projection, otherwise the Congé below is apt to be slighted. The Bead and Congé should have their full measure of 180 degrees and 90 degrees, Fig. 111.

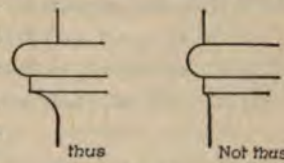

FIG. 111

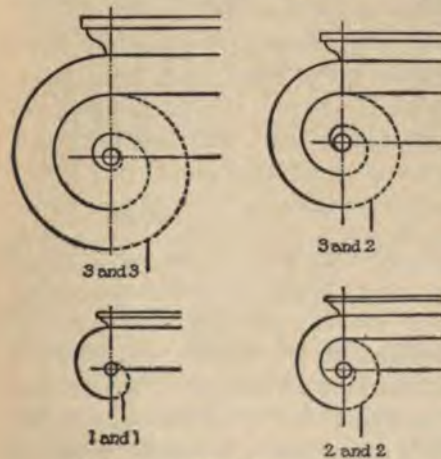

FIG. 112

The Ionic Capital, which is one-third of a Diameter in height, or four-twelfths, is also divided into three parts, but unequally. The Abacus occupies the upper quarter, or one-twelfth, and had better be put in first. The Echinus occupies rather more than half of the remaining space, namely, five-ninths. In the Composite Capital, the Abacus occupies the upper sixth, and a little more, and the Echinus and the Astragal the next one, Fig. 82.

The Eyes of the Ionic Scroll are in line with the top of the Astragal and with the lower Diameter of the Column, and should be put in first, Fig. 112. The Scrolls make three

complete turns and finally are tangent to the upper side of the eye. They can best be drawn by putting in first three semicircles on the outer side, and then three smaller ones on the inner side. In working on a small scale, two semicircles on each side will suffice, or three on the outer side and two on the inner, as in the plates. But one is never enough. The Eyes of the Composite and of the Roman Ionic Capitals are set nearer together, Fig. 82.

In drawing a Corinthian Capital, Fig. 113, it is best to put in first the Astragal and the lower line of the Architrave, carrying up on each side the outer lines of the Shaft; then the Abacus, Fleuron, and Scrolls. The double scroll at the corner falls just outside these vertical lines. It appears

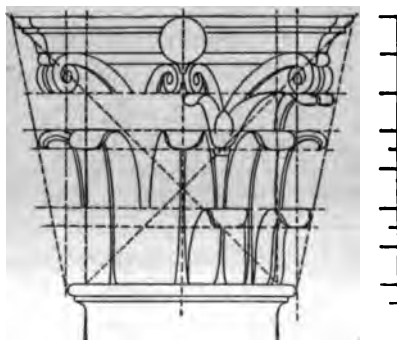

FIG. 113



FIG. 114

slightly elliptical in shape, not circular, and the outer scroll is more elliptical than the inner, being more foreshortened. The small scrolls under the Fleuron are also foreshortened into ellipses. Then the five leaves of second row, the middle one in elevation, the two side ones in profile, and the other two at 45 degrees, carrying down the mid-ribs to the Astragal. Their tips turn down half a sixth, those of the corner leaves coming just on the outer lines of the upper shaft. Of the four leaves of the lower row, the two inner ones occupy the spaces between these mid-ribs, and the ends that turn over fall entirely within the outline of the lower parts. The two outer leaves extend on either side slightly beyond the width of the shaft below, and their tips fall just

outside the lower line of the leaves, being about six-sixths of a Diameter apart. They accordingly come just over the outer lines of the lower Diameter, just as the tips of the corner leaves above them come on the lines of the upper Diameter.

A line drawn tangent to the Astragal and to the Abacus is also tangent in all three rows of leaves, very nearly. The Caulicoli, the Buttons, the third row of leaves, and the lower parts of the Volutes follow, in this order.

The smaller the scale of the drawing, the more straight and upright should the Acanthus leaves be made, Fig. 114.

---

#### THE GREEK ORDERS

**28.** Although the different examples of the Greek Doric and Ionic Orders differ considerably among themselves, both in the proportions of the Columns and in the treatment of details, the proportions of the Entablature are tolerably uniform and are, in general, the same for both Orders, the Architrave and Frieze being both about three-quarters of a Diameter in height and the Cornice about half a Diameter, Figs. 115 and 122. The Entablatures, as has been said, are about two Diameters high, however tall or short the Columns may be. Their chief characteristic is the height of the Architrave and the shallowness of the Cornice. The Diminution and the Entasis of the Columns begin at the bottom of the Shaft.

**29. The Greek Doric.**—The Greek Doric, Plate XIV, has no Base, the Shaft standing upon three large steps, the upper one of which is called the *Stylobate*, Fig. 115. It has generally twenty Channels, Fig. 116, which are generally elliptical in section, but some small Columns have only sixteen, or even, as at Argos, fourteen, Fig. 117. In a number of examples, an Arris instead of a Channel comes on the axis of the Column, as is seen both at Argos and at Assos, Fig. 118. Instead of an Astragal, a groove, or *Sinkage*, separates the Shaft from the Necking of the Capital, and the Channels



FIG. 115

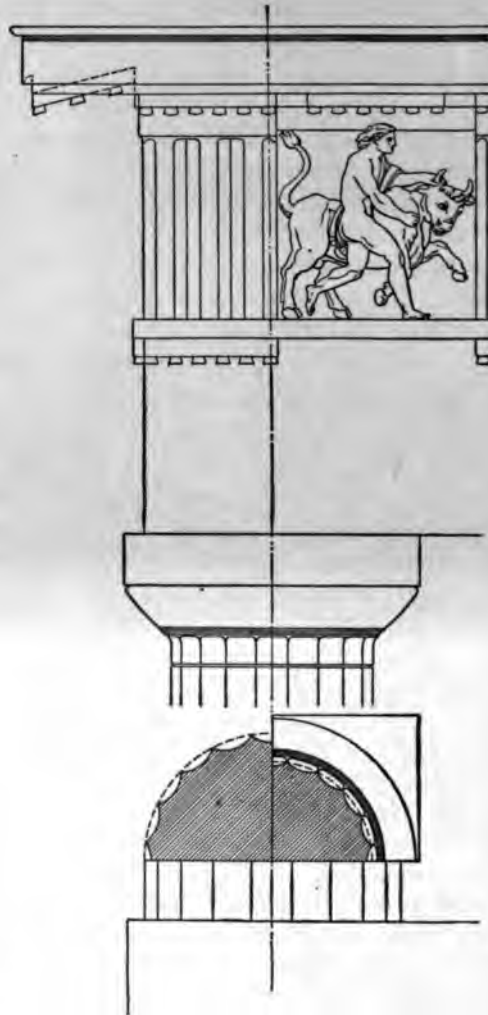
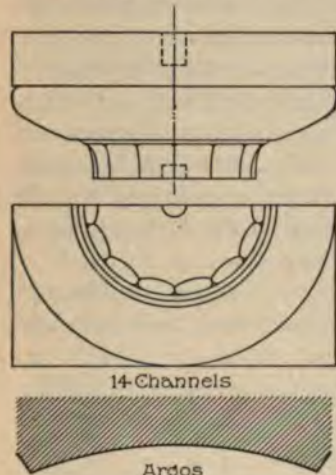

FIG. 116

are carried past it quite up to the Fillets at the base of the Echinus, Fig. 116. These Fillets vary in number. They are not vertical on the face, but follow and continue the



14 Channels

Argos

FIG. 117

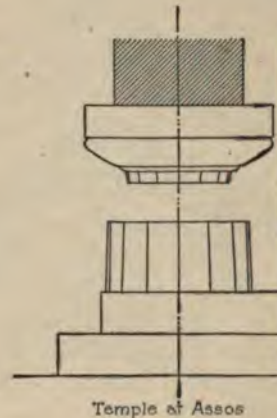

Temple of Assos

FIG. 118

slope of the Echinus, and their upper surfaces are also beveled, Fig. 119. The Echinus itself has an elliptical or hyperbolic profile, the earlier examples being the most convex and the later ones hardly differing from a straight line. The Abacus has no mouldings.

The Architrave also is plain, and is crowned by a Tænia, below which is a broad Regula and six short Guttæ. In the earlier examples, the face of the Architrave is set just over and in line with the upper Diameter of the Shaft, but in the later ones it overhangs, coming over the lower Diameter, and the Echinus is made steeper, as well as straighter, as has been said, as if to support it.



FIG. 119

The Triglyphs in the Frieze are shorter and broader than in the Roman Doric, and are set flush with the Architrave



below, the Metopes being set back. They are also thicker than the Roman Triglyphs, and the Channels are deeper, those at the edges cutting back at an angle of 45 degrees, the others generally at 60 degrees, and they run nearly up to the broad Fillet, or Band, that constitutes the Cap of the Triglyph.



FIG. 120

This is only as wide as the Triglyph itself, not breaking round the corners, and it is not continued between the Triglyphs, the Cap of the Metopes being narrower.

As in Vignola's Denticulated Doric, the Mutules on

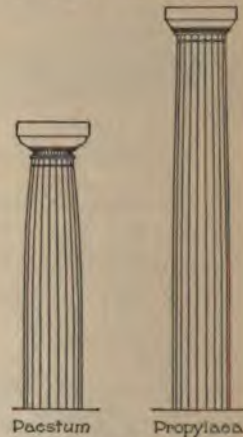

FIG. 121

the Soffit of the Corona slope up, and have only eighteen Guttæ, and they occur over the Metopes as well as over the Triglyphs, Fig. 120. The Mutules are thicker than those in the Denticulated Doric, though not so thick as in the Mutulary. The Cymatium generally consists of an elliptical Ovolo and a Fillet, the Soffit of which is beveled. But different examples vary in almost every one of these particulars.

At the corner of a building the Triglyphs are set, not over the axis of the Column, but at the extreme end of

the Frieze, two coming together and making a solid block. As the Metopes do not vary in size, being nearly square, this brings the three corner columns nearer together than the others.

In the best Greek examples the columns all slope in a little, so that the corner column, which is a little bigger than the others, has its inner face nearly vertical. The horizontal lines curve slightly, being convex up, the vertical faces incline a little, either out or in, and the mouldings are, as has been said, generally elliptical or hyperbolic in section, rather than arcs of circles.

The Columns vary in height from about five to eight Diameters, the earlier ones being the shortest, and the Entasis, or Curvature in the outline of the Shaft, and the Diminution in the width of the Shaft, from bottom to top, which sometimes amounts to one-third of the Diameter, are much more pronounced in the earlier examples than in the later ones, Fig. 121. This seems to show that the original of the Doric column was not a wooden post, as has been thought, nor a pile of masonry, but a piece of rubble work, probably, like the rubble walls, covered with stucco.

**30. The Greek Ionic.**—The general proportions of the Greek Ionic Entablature, Plate XV, are, as has been said, about the same as in the Doric, but the Columns are more slender, varying from about seven Diameters in height to more than ten, and the Architrave, Frieze, and Cornice are often made very nearly equal in height, Fig. 122.

The Base is like the Attic Base, except that the Scotia is larger, constituting the principal feature, that the upper Torus is larger than the lower one, that the Fillet above the Scotia projects as far as the face of this Torus, and that there is no Plinth. As the base is still half a Diameter high, the upper Torus and Scotia are very much larger than in the Roman Attic Base. The lower Torus is sometimes very small indeed, and is occasionally omitted altogether, as at Samos, Fig. 123, and in one of the Choragic columns on the south side of the Acropolis at Athens, Fig. 69.

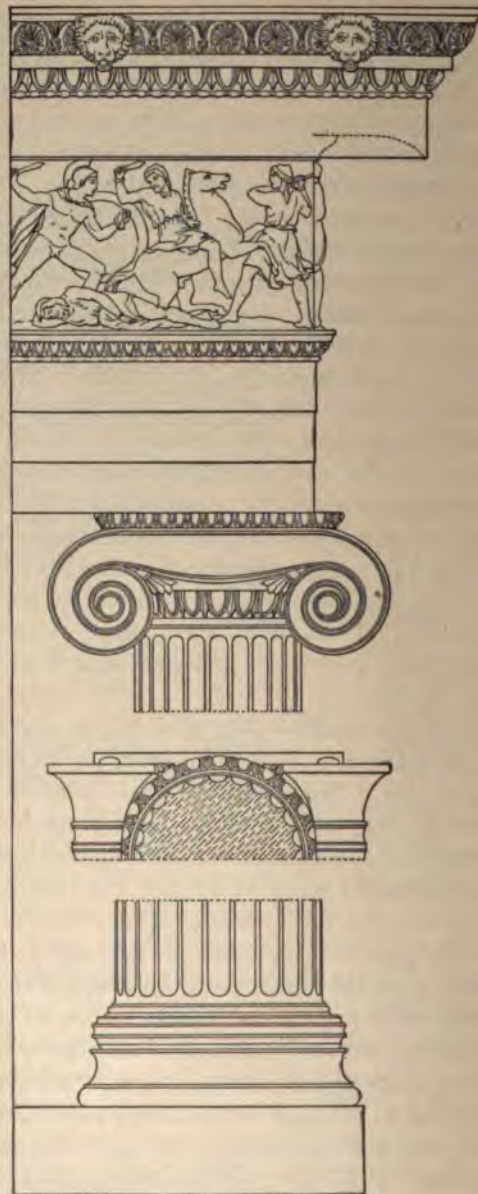

FIG. 122

The Shaft is fluted just as in the Roman Ionic, having twenty-four channels, and the Capital resembles, in general,



FIG. 123

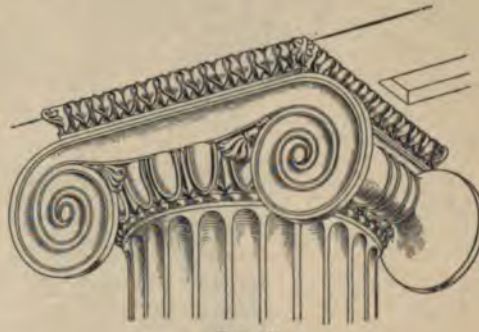

FIG. 124

Vignola's Capital with Balusters. But the Scrolls are much larger, measuring a full diameter and a half from side to side, and two-thirds of a Diameter from the Architrave to the bottom of the curve. The Capital, measured from the Architrave down to the Astragal, is half a Diameter high, instead of a third, the Abacus is very small, consisting generally of a single Ovolo, and the *Cushion* between the Abacus and the Echinus very wide, its lower outline being curved downwards, Fig. 124. The sprigs of honeysuckle, accordingly, do not cover the eggs and darts, five of which are visible between the Scrolls, instead of three.



FIG. 125

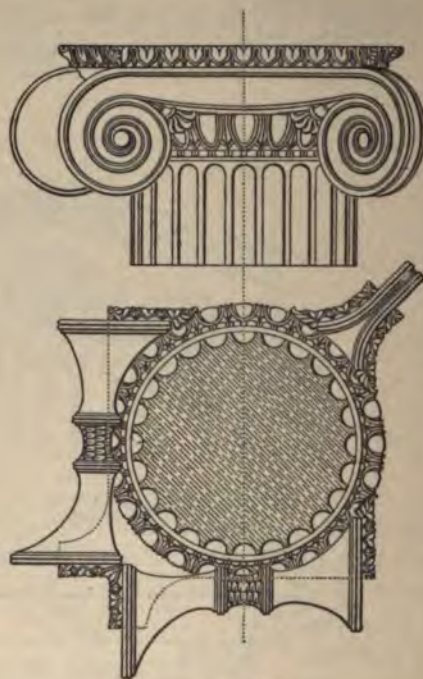

FIG. 126



FIG. 127

The Architrave is sometimes plain, sometimes divided into two or three bands. The Frieze, or Zoöphorus, is wide, and the Bed Mould that crowns it is often countersunk into



FIG. 128



FIG. 129

the Soffit of the Corona, so that it does not show in elevation, Fig. 122. It is noticeable that though Dentils are, historically, a distinctively Ionic feature, they are omitted in many Greek examples. The Cymatium is a large Cyma

Recta, and has a Fillet and Bead below it, which is sometimes undercut, so as to make a little Beak Moulding.

But here, as in the Greek Doric, there is a great variety in the details of different buildings.

The four faces of the Capital are sometimes made alike, with double Scrolls on each corner, as in the Roman Ionic,

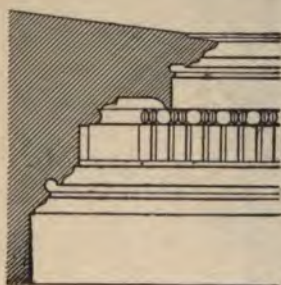

FIG. 130



FIG. 131

and these Scrolls are sometimes connected under the Abacus by a continuous curve, convex up, instead of by a horizontal line, Fig. 125. Sometimes a corner column shows Scrolls on



FIG. 132

the two outer faces and Balusters on the two inner ones, the double scroll on the corner projecting at 45 degrees, Fig. 126. Some examples have a wide Necking, adorned with the honeysuckle ornament, below the Echinus, Fig. 127.

A few Corinthian Capitals are to be found in Greece, but the buildings in which they occur are in other respects Ionic, or even Doric, Fig. 128.

In the later Greek colonies in Southern Italy are found interesting varieties of all the Orders.

Their most marked peculiarity is the treatment of the details, Fig. 130. The Triglyphs and Dentils are long and slender, and the mouldings refined in outline and sometimes

STATES



REVISED BY  
DIRECTOR



THE NEW YORK  
PUBLIC LIBRARY  
ASTOR, LENOX  
TILDEN FOUNDATION



REVISED BY  
DIRECTOR

THE NEW YORK PUBLIC LIBRARY

ASTOR, LENOX, TILDEN FOUNDATION



# PEDESTALS

*International Textbook Company  
Scranton, Pa.*

## THE AMERICAN VIGNOLA

*Copyright, 1904, by William R. Ware  
Copyright, 1904, by International Textbook Company*

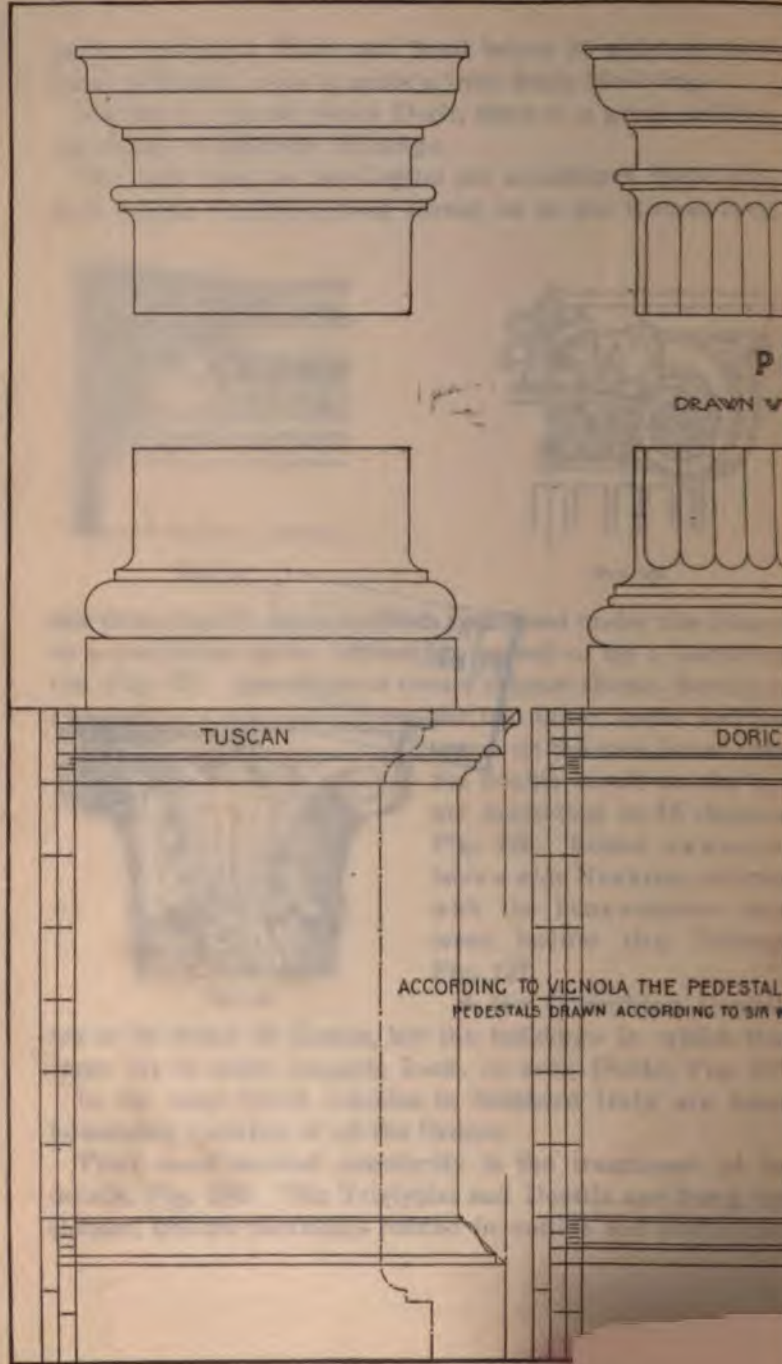

# D PILASTERS



## PILASTERS

UPPER DIAMETER EQUAL  
LOWER DIAMETER



ATTIC  
BASE-

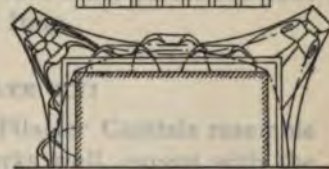

PLAN OF CORINTHIAN PILASTER CAPITAL  
DOTTED LINE SHOWS LIP OF BELL

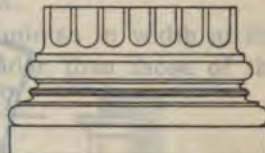

IONIC

## PILASTERS

THE HEIGHT OF THE COLUMN, IT IS FREQUENTLY LESS  
ES. DOTTED LINES SHOW VIGNOLA'S PROFILES



CORINTHIAN AND COMPOSITE



separated by deep grooves, rectangular or circular, which are not to be mistaken for mouldings. The Architraves lose their importance, the Ionic Scrolls are often diminished in size, and the egg-and-dart moulding is changed into what are sometimes called *Filberts*, Fig. 130. The Corinthian Capitals receive a local development quite unlike that which was finally adopted in Rome itself, as may be witnessed at Tivoli, Fig. 131, Pompeii, and Herculaneum, Fig. 132. Since the revival of Greek architecture other variations have appeared in France, Germany, and Italy.

PILASTERS—PLATE XVI

31. The Romans made their Pilaster Capitals resemble those of the Columns. This works well, except with the Ionic Capital, in which the projecting Echinus presents an almost insuperable difficulty, Fig. 133.

As *Pilasters* do not generally diminish in width at the top, their Capitals are one-fifth broader than those of the

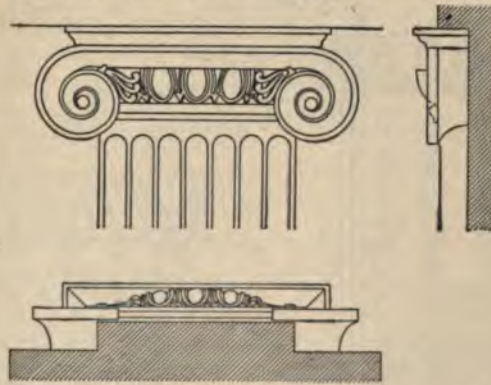

FIG. 133

Columns. But Pilasters are often made half a sixth narrower than the Columns at the bottom, and half a sixth wider at the top, having thus a uniform Diameter of five-sixths and a half. In the Corinthian Pilaster Capital, the extra space is taken up by making the leaves a little broader, and setting them farther apart, Fig. 134.



Column



Pilaster

FIG. 134



Column



Pilaster

FIG. 135

Pilasters generally project from the wall a quarter of their diameter, but sometimes have to be made thicker in order to receive string courses or other horizontal mouldings that they cut across. If made much thicker than this, they are apt to look thicker than the columns alongside them, and piers always do, noticeably enhancing the slenderness of the columns near them.

The Greeks gave their Pilasters Bases like those of the Columns, but Capitals of their own, composed of a series of mouldings, Fig. 135.

Pilasters are preferable to half columns, which always look smaller than they are, and have a mean appearance. Moreover, any mouldings that they interrupt seem to cut them in two, Fig. 136. In these respects, three-quarter columns are better, though they are apt to look clumsy, and they inevitably make an awkward junction with the wall behind them. They also make it uncertain which is the principal supporting member, the wall or the column.

#### PEDESTALS—PLATE XVI

32. As has already been said, a short Pier is called a Post, and, if it supports something, a Pedestal, and the Pedestals that support Columns are generally made one-third the height of the Column. The Cap is one-ninth the height of the Pedestal, and generally consists of a Bed Mould and Corona.

There is no Cymatium, a gutter being obviously out of place, but the Corona is crowned by a fillet and small Cyma Reversa. The Base, which is two-ninths of the height of the Pedestal, or, according to Vignola, only one-ninth, like

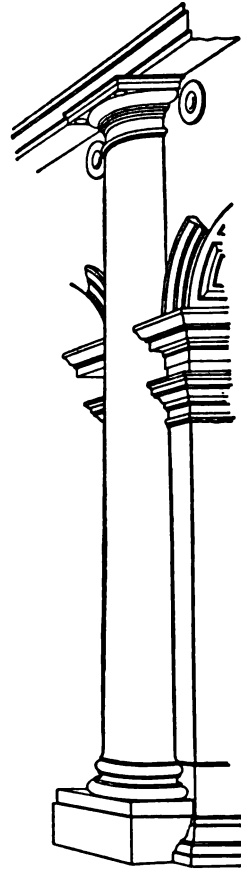

From the Farnese Palace

FIG. 136

the Cap, consists of a Plinth and Base Mouldings, among which a Cyma Recta is generally conspicuous, with a Torus below it.

The mouldings, in both Cap and Base, are fewer and consequently larger and simpler in the Tuscan and Doric Orders than in the Ionic and Corinthian, the Tuscan, according to Vignola, having no Corona, and the Corinthian a Necking and Astragal. The Cap projects less than its own height,

in many examples, and the Plinth just as much as the Corona.

But Pedestals vary greatly both in their proportions and in their mouldings.

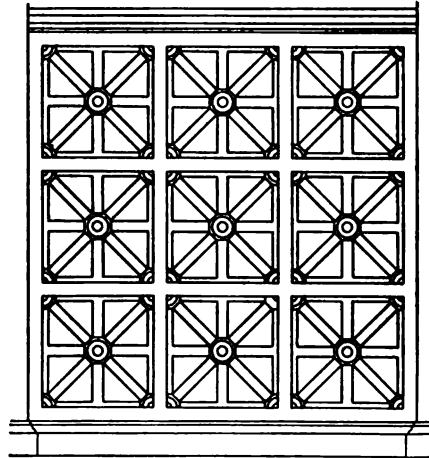

FIG. 137

either case the wall or parapet has a Cap and Base, which may or may not be like those of the Pedestals or Posts. A similar strip of wall, with the wall continued above the Cap, is called a *Continuous Pedestal*, Fig. 143. This often occurs between the Pedestals that support Pilasters.

**34. Balustrades.**—In antiquity, Parapets were often pierced by triangular penetrations, apparently in imitation of wooden fences, Fig. 137. But in modern times the openings in Parapets are generally filled with a sort of colonnade of dwarfed columns called **Balusters**. These frequently occupy the whole space between one Post or Pedestal and the next, forming a **Balustrade**, Fig. 138. If the distance is great, so that the Cap has to be made of several lengths

**33. Parapets.**—A wall low enough to lean upon is called a **Parapet**, and whether low or high is often strengthened by occasional Posts or Pedestals, sometimes of the same height, sometimes higher. In

of stone, a block called an *Uncut Baluster* is placed under the joint. Not more than a dozen Balusters should occur together without such interruption. Against the Pedestal

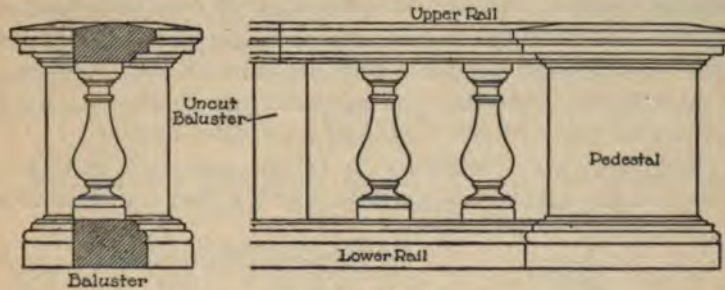

FIG. 138

is often set a *Half-Baluster*, or, which is better, half of an *Uncut Baluster*, to support the end of the *Upper Rail*, Fig. 139.

**35.** The Cap and Base of the Pedestals, or of the Parapet or Continuous Pedestal, are called in a Balustrade the *Upper* and *Lower Rails*.

The Baluster supports the *Upper Rail* as a Column supports an Entablature, and stands upon the *Lower Rail* as upon a Stylobate, Fig. 139. It has its own Cap, the height of which, including the

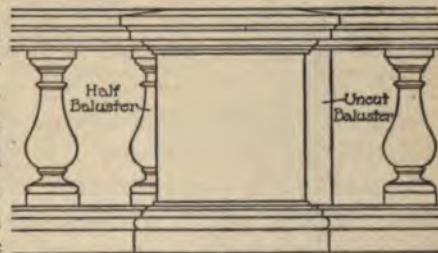

FIG. 139

Astragal, is one-quarter the height of the Baluster, and which consists of a plain Abacus, Echinus, and Fillet and Necking. These three members are of equal height, as in the Tuscan and Doric Capitals.

The Base of the Baluster is also one-quarter its total height and resembles the Attic Base. The Scotia, as in the Greek Attic Base, is generally made the principal member.

Between the Cap and Base is the Shaft, or *Sleeve*, which has the outline of a Quirked Cyma Reversa, the greatest diameter, or *Belly*, coming at about one-fourth of its height,



or one-third the height of the Baluster, Fig. 140. Its width at this point is also one-third the height of the Baluster, as is also that of the Plinth of the Base, exactly, and the width of the Abacus, almost. The Necking is less than half as wide. The point of contrary flexure in the Cyma Reversa is half way between Cap and Base, or between the Upper and Lower Rails. But these proportions are made somewhat lighter for use with the Ionic and Corinthian Orders.

The Rails are sometimes, in height, one-sixth and two-sixths of the space between them, like the Cap and Base of a

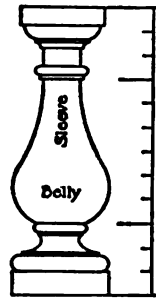

Baluster  
FIG. 140



FIG. 141



FIG. 142

Continuous Pedestal; but they are often made much heavier, even one-third and one-half.

Instead of the Cyma Reversa, a Beak Moulding is often used, Fig. 141, and other variations are frequent. Of these, the most important is the so-called *Double Baluster*, which consists of two small Balusters, set together base to base, Fig. 142. Vignola also used a high block under the Plinth. Balusters are often made square in section, like piers, instead of round, like columns.

Balusters are set about half their height apart, on centers.

A Balustrade, like a Parapet, is intended to lean upon, and should not be more than about 3 or 4 feet high. While, therefore, Columns and Entablatures are proportioned to the size of the buildings in which they occur, varying in height from 10 or 12 feet to 50 or 60, Balustrades, like steps, are proportioned to the size of the human figure, and in large buildings

are relatively much smaller than in small ones. They thus serve, as do steps, and as does the human figure when introduced into a drawing, to indicate the scale of a building.

But in very large buildings balustrades have sometimes been made of colossal dimensions, that on the top of the front of St. Peter's, for example, being about 8 feet high.

#### ATTICS

**36.** When a Parapet is placed on top of an Entablature it is called an Attic, that is to say, an "Athenian" story,

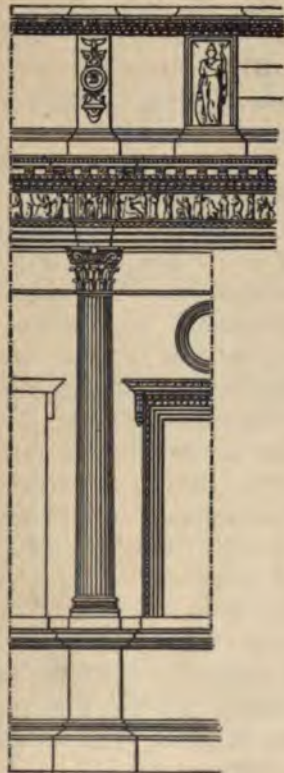

FIG. 143



FIG. 144

Fig. 143. Like Pedestals, Attics vary much in size and in architectural treatment. They are generally made about a

quarter as high as the order below, and should not be more than a third, and they should have a high Plinth, or even a double Plinth, Fig. 144, so as not to be too much hidden by the projection of the Cornices on which they stand.

The place of an Attic is often taken by Balustrades, Fig. 145, which also should have high Plinths, below the lower rail.



FIG. 145

#### PEDIMENTS—PLATE XVII

37. The Gable upon a Classical building is called a **Pediment**, Fig. 146. It consists of a triangular piece of wall, called the *Tympanum*, which is in the same plane as the Frieze below; of a *Horizontal Cornice*, which divides the Tympanum from the Frieze; and of two pieces of inclined cornice that surmount the Tympanum. The inclined, or *Raking Cornice* is like the cornice that crowns the

wall on the sides of the building, but the Cymatium is a little wider. The Horizontal Cornice has no Cymatium, and generally terminates in a Fillet, called the *Split Fillet*, which divides at the angle where the two Cornices come together.

If the Cymatium is a Cavetto, the under side of the Fillet beneath it is beveled, either on the rake or along the wall; if it is an Ovolo, the same thing happens to the Fillet above it, Fig. 147. With the Cyma Reversa both occur, with the Cyma Recta, neither, the fillets having no soffit. This is one of the reasons for employing this moulding in this place.

When a Cyma Recta is used in the Cymatium, it occurs in four different forms, Fig. 148; viz.: (1) the profile of the moulding along the wall; (2) the profile of the raking moulding;

CLASSIC IONIC



ROMAN IONIC



THE NEW YORK  
PUBLIC LIBRARY

ROMAN CORINTHIAN



THE NEW YORK PUBLIC LIBRARY  
ASTOR LENOX TILDEN FOUNDATION  
1054 FIFTH AVENUE  
NEW YORK, N. Y.

Copyright, 1902, by William R. Ware  
Copyright, 1904, by International Textbook Company

THE AMERICAN VIGNOLA

International Textbook Company  
Scranton, Pa.

GREEK IONIC

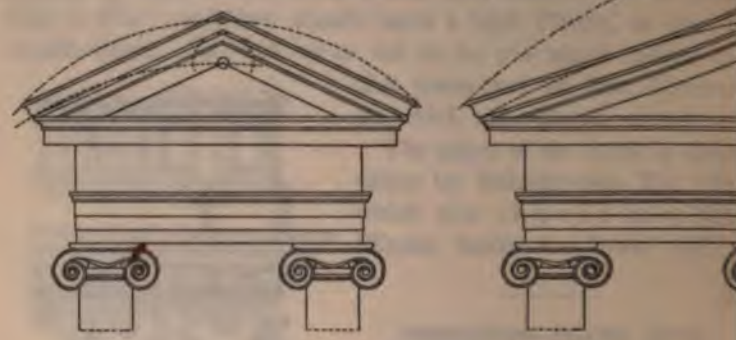

ROMAN IONIC

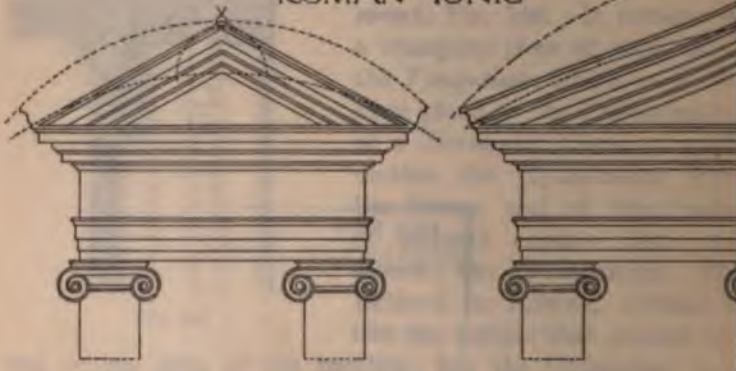

ROMAN CORINTHIAN



# MENTS

COARSE DOTTED LINE SHOWS  
RULE OF "VIGNOLA"

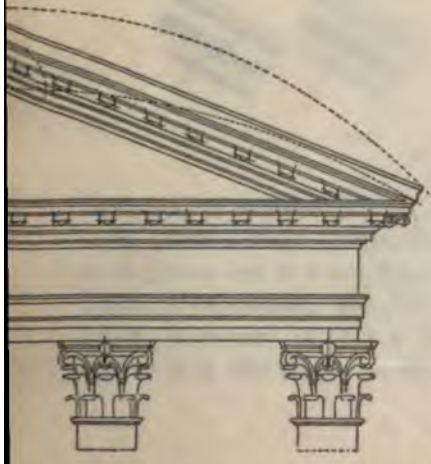
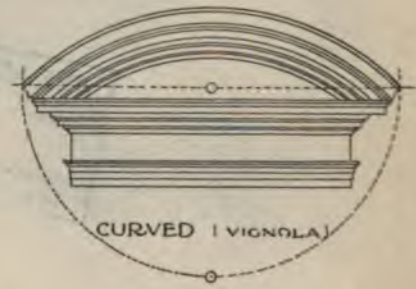
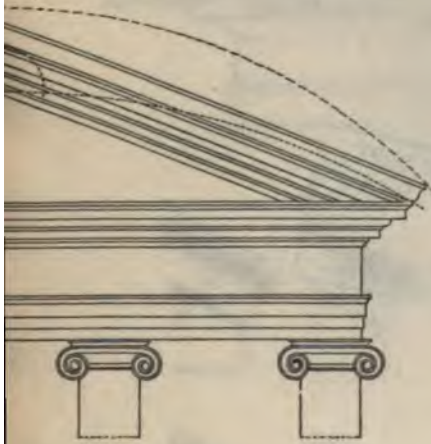
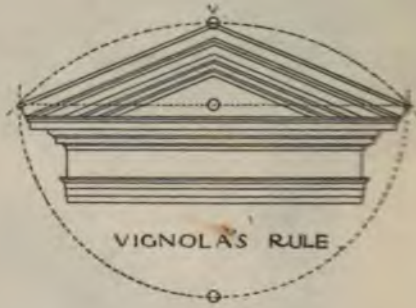
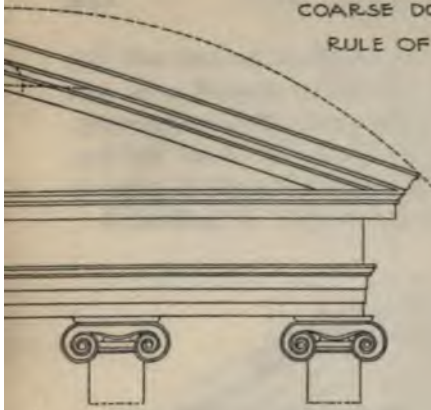

BROKEN PEDIMENT



(3) the line of intersection of these two mouldings, which lies in a vertical plane, set at 45 degrees; (4) the line of intersection of the two raking mouldings at the top. (1),(2), and (4) have the same projection but different heights; (1) and (3) have the same height but different projections.

According to Vignola, the obtuse angle at the top of the

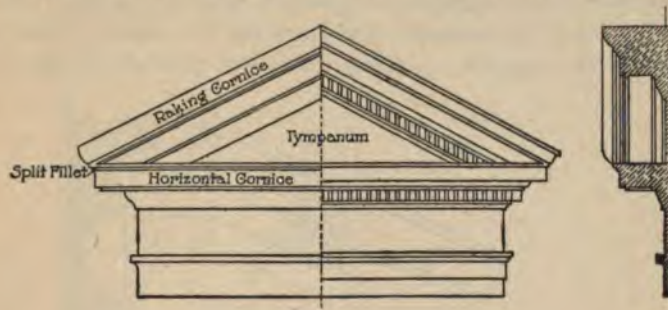

FIG. 146

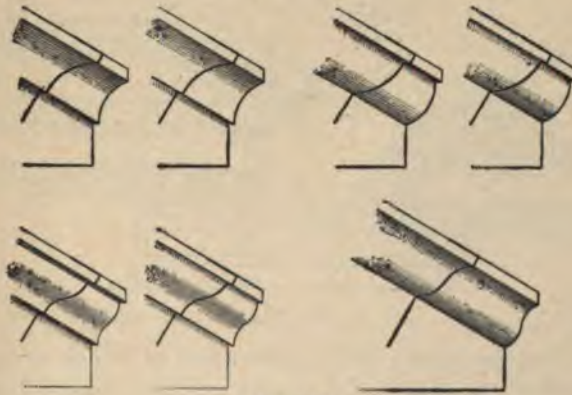

FIG. 147

Pediment is included within an arc of 90 degrees; it accordingly gives a slope of  $22\frac{1}{2}$  degrees. This is a good rule for most cases; but if a building is high and narrow, the slope needs to be steeper, and if it is low and wide, flatter. Inasmuch, however, as, for a building of a given width, the higher it is, the larger is the scale of the Order employed



and of all the details of the Order, it follows that, for a given width of front, the larger the mouldings are, the steeper must be the slope.

Upon this is founded the following rule for the slope of Pediments, devised by Stanislas L'Eveillé, Fig. 149: Taking the upper line of the Horizontal Cornice as one side, construct below it an equilateral triangle, and taking the vertex of this triangle as a center, and its sides as a radius, describe an arc of 60 degrees. Taking, then, the summit of this arc

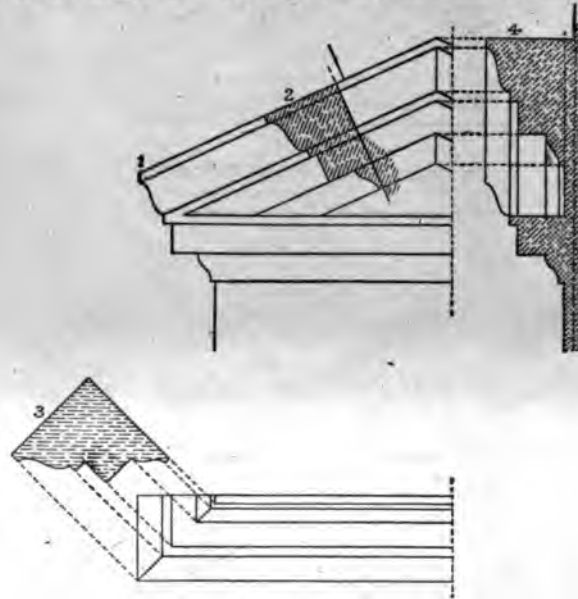

FIG. 148

as a center, describe a circle, the radius of which is equal to the width of the horizontal cornice. Lines drawn from the extremities of the Corona tangent to this circle will give the upper line of the Raking Corona. It is obvious that the larger the cornice, relatively to the length of the front, the steeper will be the slope. It is also plain that this rule gives steeper Pediments for the Corinthian and Ionic Orders than for the Doric and Tuscan, and for the Roman Orders than for the Greek, the cornices being wider.

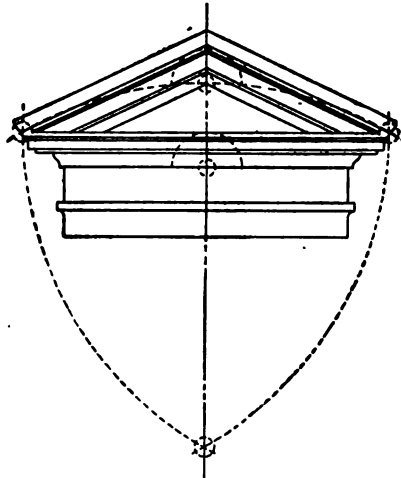

FIG. 149

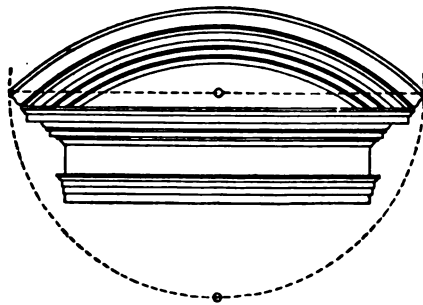

FIG. 150

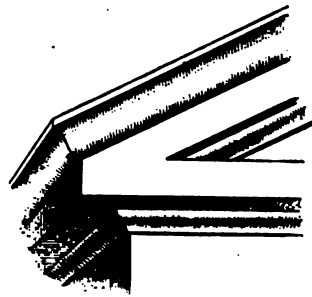

FIG. 151

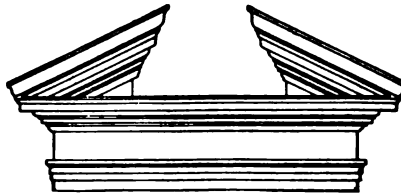

FIG. 152

Circular, or *Curved, Pediments* have a sweep of 90 degrees, Fig. 150, starting at an angle of 45 degrees.

When pediments are used merely for ornament the upper part is sometimes omitted, giving a *Broken Pediment*, Fig. 152.

If the moulding that crowns the Corona is omitted, the faces of the three Coronas are continuous, Fig. 151. This was exemplified in antiquity by the recently discovered Treasury of the Cnidians at Delphi.

---

#### INTERCOLUMNIATION, OR THE SPACING OF COLUMNS—PLATE XVIII

38. The space between the two columns, measured just above their bases, is called an *Intercolumniation*. It is one Diameter less than their distance apart on centers, or on edges.

Columns are said to be *Coupled*, or to have a *Pycnostyle, Systyle, Diastyle, or Arcostyle Intercolumniation*, according as they are set close together, or are one, two, three, or four Diameters apart, as nearly as may be; i. e., about one, two, three, four, or five Diameters on centers. The *Systyle* and *Diastyle* are the most usual, with an *Intercolumniation* of two or three Diameters. But *Coupled Columns* cannot be nearer than one and one-third Diameters, on centers, instead of one Diameter, on account of the projection of their bases, and in the Ionic, Corinthian, and Composite Orders, not nearer than one and one-half Diameters, on account of the projection of their Capitals. The *Intercolumniation* of *Coupled Columns* is accordingly one-third or one-half of a Diameter, or even a little more, to prevent the Bases or Caps from actually touching.

So also the *Pycnostyle Intercolumniation* is made one and one-fourth Diameters, instead of one Diameter (i. e., two and one-fourth Diameters o. c., instead of two), to avoid crowding. The ancients thought that even the *Systyle columns*, with an *Intercolumniation* of two Diameters, came too near together, and preferred what they called the *Eustyle Intercolumniation*, of two and one-half Diameters (or three and

SUPERPOSITION OF INTERCOLUMNS

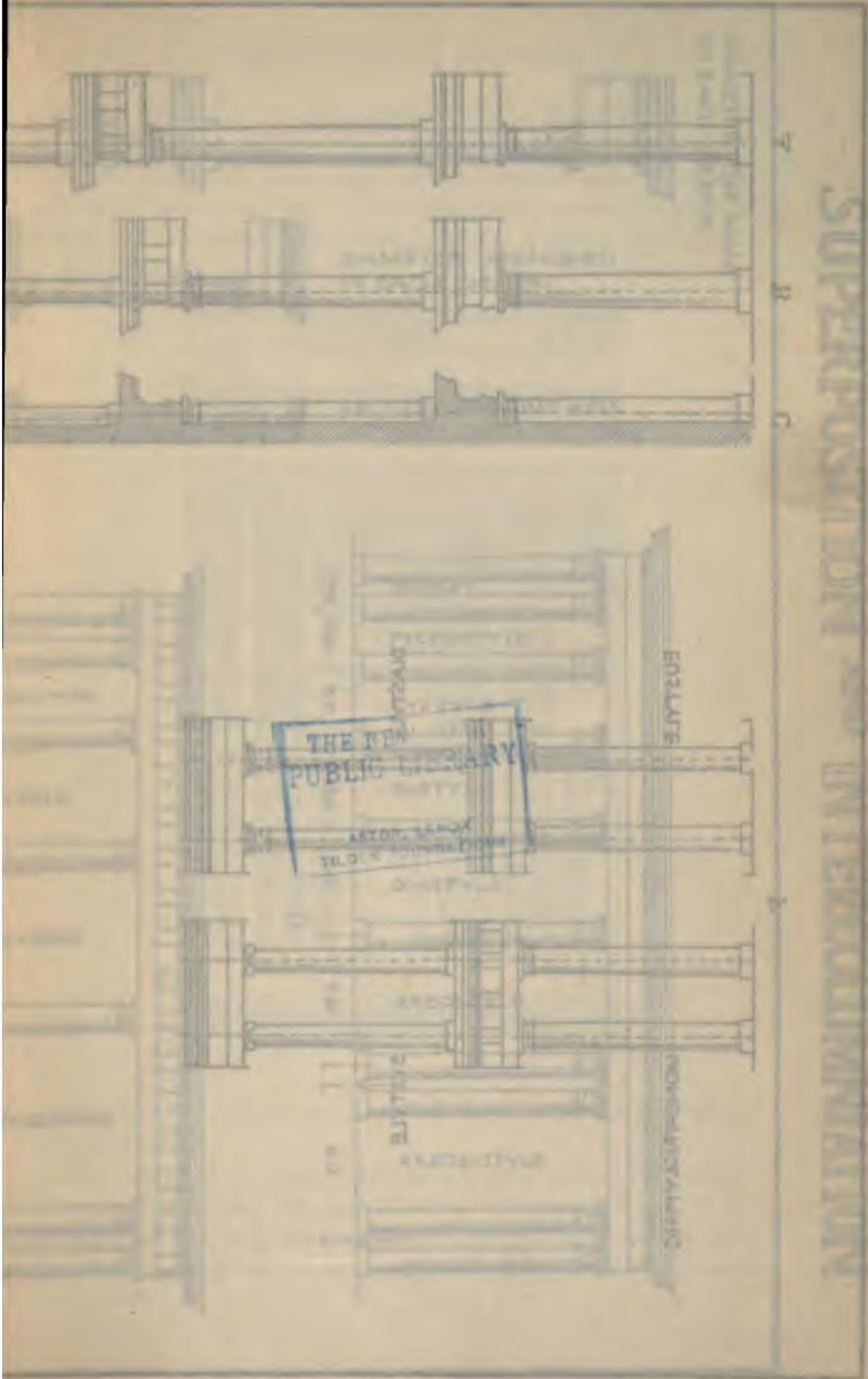

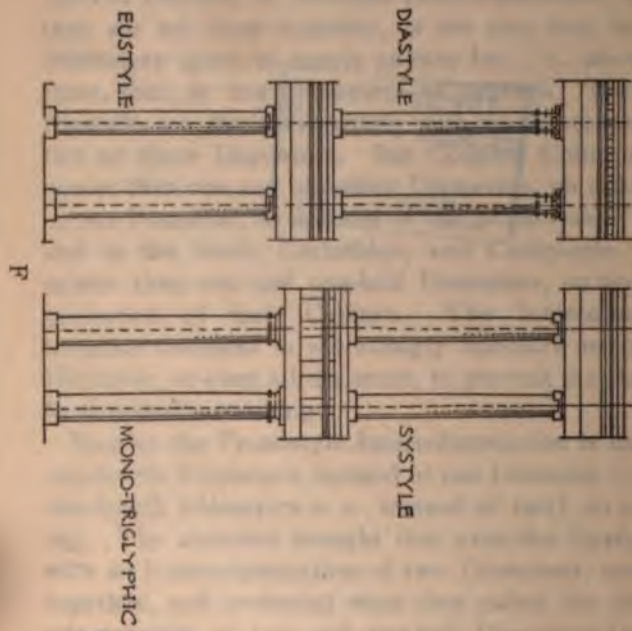
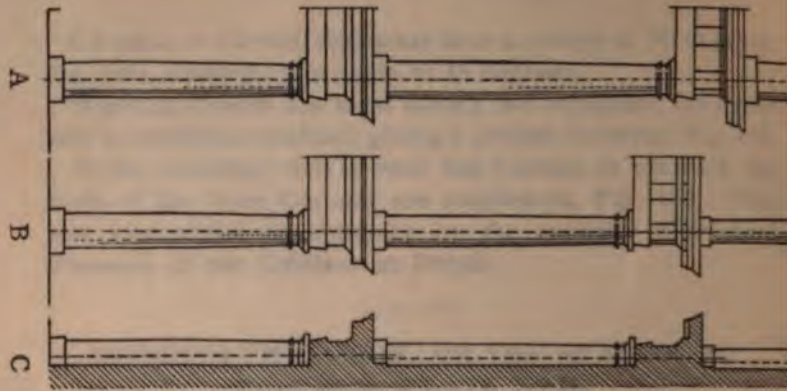

TOLA

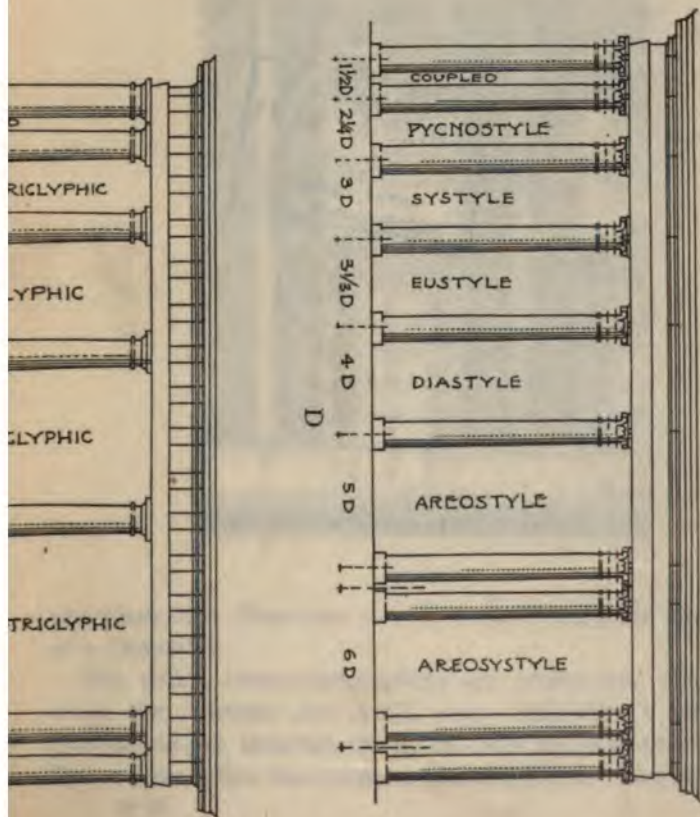
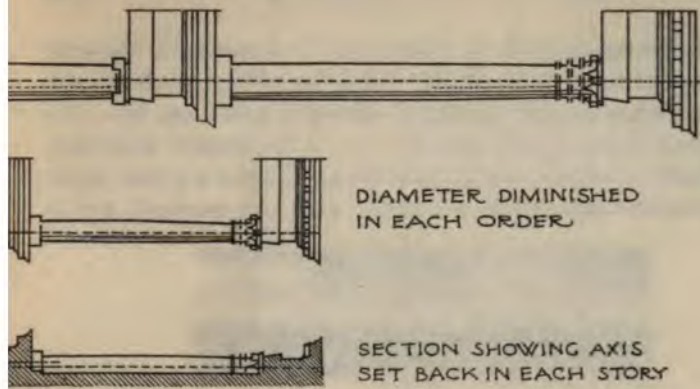

PERPOSITION AND INTERCOLUMNIA

SECTION THROUGH WALL  
SEE BACK OF PAGE 250

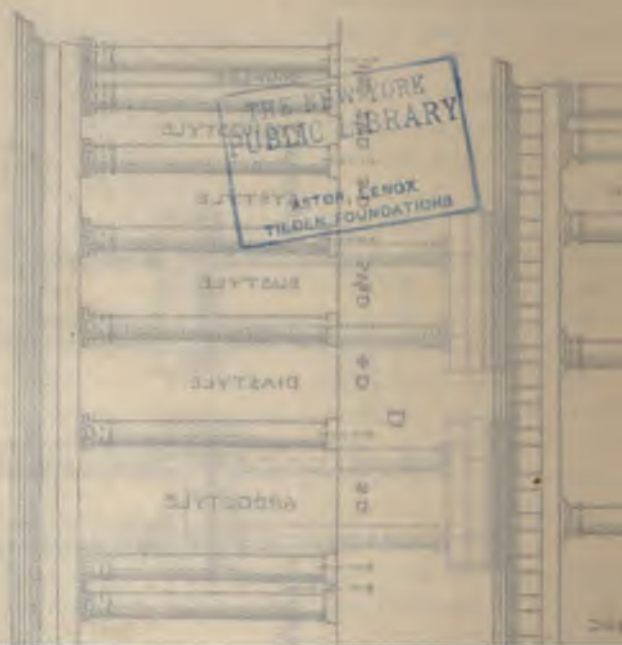

one-half Diameters o. c. in place of three Diameters). But the moderns prefer to make the Eustyle Intercolumniation two and one-third Diameters (setting the columns three and one-third Diameters o. c.), as this brings every Column in Ionic and Corinthian colonnades exactly under a Dentil, and every alternate one just under a Modillion, the Dentils being



FIG. 153

one-sixth of a Diameter o. c. and the Modillions two-thirds of a Diameter.

The wider Intercolumniations are preferable, obviously, when the columns are small, since otherwise it might be difficult to get between them, and the Systyle, or even the Pycnostyle, when the columns are very large, since otherwise



it might be difficult to find stone architraves long enough to span the interval. But the ancients used Tuscan Columns chiefly with wooden architraves, setting them as much as seven Diameters apart, which is called *Tuscan Intercolumniation*, and which makes the space between the columns about square. In modern times, also, an arrangement of coupled columns has been employed, called *Areostyle*, the columns being set half a Diameter apart, and the space between the pairs of columns made three and one-half Diameters. This is greater than the Diastyle Intercolumniation and less than the Areostyle by half a Diameter. From the axis of one pair of columns to that of the next pair the distance is six Diameters. If in a Systyle Colonnade, with the columns three Diameters on centers, the alternate columns are moved along till they nearly touch the intervening ones, the result is an Areostyle Colonnade. This was first used by Perrault in the Eastern Colonnade of the Louvre, Fig. 153.

In actual practice these rules for Intercolumniation are seldom exactly followed.

#### DORIC INTERCOLUMNIATIONS

**39.** In the Doric Order, since the Columns come exactly under the Triglyphs and the Triglyphs are one and one-fourth Diameters o. c., as on edges (the width of the Triglyph being one-half of a Diameter and that of the Metopes three-fourths of a Diameter), the distance of the Columns on centers must needs be a multiple of one and one-fourth Diameters.

This makes the coupling of Doric Columns difficult, since, even if the Bases touch, the distance between axes is still one and one-third Diameters, which is more than that of the Triglyphs by one-twelfth of a Diameter. This slight discrepancy can, however, be got over by making each Base a trifle narrower, or the Triglyphs and Metopes a trifle wider, or by putting the Columns not exactly under the Triglyphs, or by employing all these devices at once.

If the Columns are set under alternate Triglyphs so that there is one Triglyph over the intervening space, their

distance apart o. c. is two and one-half Diameters. The Intercoluniation is then one and one-half Diameters, and is said to be *Monotriglyph*. This is the most common arrangement. But if the scale is small, it is usual, at least at the principal entrance of a building, to have two Triglyphs over the opening, the Columns being three and three-fourths Diameters on centers. The Intercoluniation is then two and three-fourths Diameters, and is called *Ditriglyph*. Still wider spacing is employed when the Architraves are of wood.

When two, four, six, eight, ten, or twelve Columns are used in a Colonnade or Portico, it is said to be *Distyle*, *Tetrastyle*, *Hexastyle*, *Octastyle*, *Decastyle*, or *Dodecastyle*, according to the Greek numerals. Examples are found at Argos, Assos, Thoricus, and Pæstum of façades with an odd number of columns, three, five, seven, and nine, a column instead of an intercoluniation coming on the axis, giving *tristyle*, *pentastyle*, *heptastyle*, and *enneastyle* porticos. But in all these cases the entrances were apparently on the sides of the buildings, where there was an even number of columns.

---

#### SUPERPOSITION—PLATE XVIII

**40.** *Superpositton* is the placing of one Order above another, as in the Roman Amphitheaters and in many modern buildings of several stories. The more solid forms of the Tuscan and Doric are naturally placed below, and the Ionic and Corinthian above. The Composite is sometimes placed below the Corinthian, as being more vigorous. But in high buildings it is generally placed on the top story, its large details being better seen at a distance than are those of the more delicate Order.

Even when the same Order is employed in the different stories it is advisable to have the upper Columns of smaller diameter than those below, and all the dimensions diminished accordingly, for the sake of lightness. But it is still more so when different Orders are superposed, for otherwise the Doric and Corinthian stories would overpower the Tuscan and Ionic ones beneath. It is usual, accordingly, to make



FIG. 154

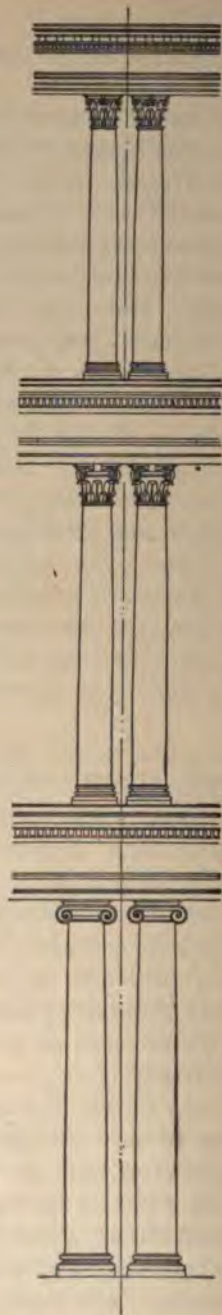
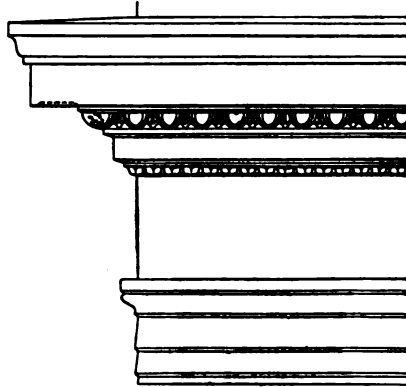

FIG. 155



FIG. 156

the lower diameter of each Shaft equal to the upper diameter of the Shaft below it, as if they were all cut from a single piece of tapering stone. This makes the scale employed in the second story five-sixths of that used in the first; in the third, twenty-five thirty-sixths, or about two-thirds; in the fourth, about three-fifths, and in the fifth about one-half, if the Five Orders are employed in regular sequence; this makes the relative height of the Orders in the successive stories to be as 7,  $6\frac{2}{3}$ ,  $6\frac{1}{2}$ ,  $5\frac{5}{8}$ , and 5, very nearly. The actual height of the stories themselves may be somewhat modified by the use of plinths and pedestals.



From the Pantheon, Rome

FIG. 157

This system of Superposition makes the distance apart of the Columns in each story, when expressed in terms of their own Diameter, six-fifths of that in the story below. A Eustyle Intercoluniation in one story thus exactly produces a Diastyle Intercoluniation in the story above, and a Doric Monotriglyph Intercoluniation, a Systyle.

$$\left(\frac{6}{5} \times 3\frac{1}{2} = 4; \frac{6}{5} \times 2\frac{1}{2} = 3\right)$$

Coupled Columns set one and one-third Diameters apart, on centers, in one story, are, in the story above, one and three-fifths Diameters o. c., and in the third story nearly two Diameters o. c. This does very well for a sequence of Doric, Ionic, and Corinthian, Fig. 154. But if the lower Columns

are Ionic or Corinthian those above had better be set nearer together, the axis of the Intercolumniation only being preserved, Fig. 155.

With this exception, Superposed Columns are set so that their axes are in the same vertical line, when seen in elevation. But in profile, as seen in section, the upper ones are set back, the wall against which they stand generally growing thinner as it goes up, Fig. 156. Since the Columns themselves also grow smaller, it would not do to leave too much space behind them. The slightly pyramidal effect that this gives to a building of several stories is of value, preventing it from looking top-heavy and high-shouldered.

#### OTHER CORNICES AND STRING-COURSES

**41.** The Five Orders worked out by Vignola are generally accepted as a standard, though they are seldom exactly followed in practice, modern as well as ancient

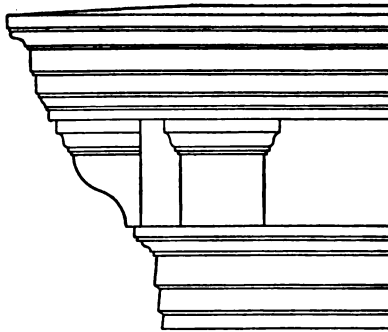

From the Fourth Order of the Coliseum

FIG. 158

examples exhibiting a great variety in the forms and proportions of the parts. But familiarity with them is of great service in designing, since they can safely be employed on all ordinary occasions, and in the earlier stages of architectural composition. Other types of nearly equal merit have been published by Alberti, Palladio, Serlio, Scamozzi, Sir

William Chambers, and others, and a great variety of cornices, both with and without friezes and architraves, have been employed in ancient and modern times to crown and



From the Villa Caprarola,  
by Vignola  
FIG. 159

protect walls that were not decorated with columns or pilasters.

Many of these show Blocks or Modillions without any Dentil Course below, as on Palladio's Composite Cornice, and in many of them the Dentil Course is plain, forming

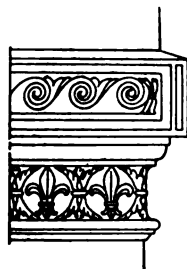

From the Farnese Palace  
By San Gallo

FIG. 160

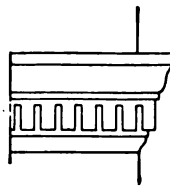
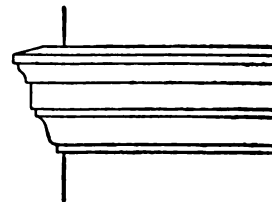

FIG. 161



String-Course from the Strozzi Palace

FIG. 162

what is called an *Uncut Dentil Course*, Fig. 157. In others, the brackets that support the Corona are brought down so as to occupy the Frieze, Fig. 158. The most important of

these is Vignola's so-called *Cantilever Cornice* used by him at Caprarola, Fig. 159. It seems to have been suggested by the *Mutules* and *Triglyphs* of his *Mutulary Doric*.

Cornices, and indeed full Entablatures, are often used as *String-Courses* to separate stories, as in the Roman Amphitheaters. But it is customary to use, instead, a lighter

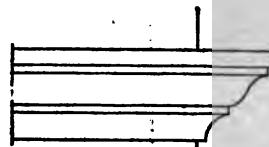

String-Course from the Palazzo Grandi  
By Bramante

FIG. 163

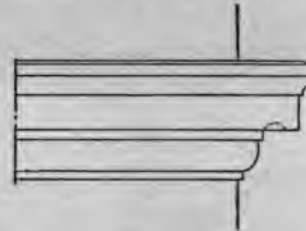

String-Course from the Sacchetti Palace  
By San Gallo

FIG. 164

form, of small projection, somewhat like the cap of a pedestal, in which the *Cymatium* and *Bed Mould* are often omitted, and the *Corona* itself sometimes diminished to a mere *fillet*, Figs. 160 to 162.

# COLOR HARMONY.

---

## INTRODUCTION.

**1. Nature of Color.**—Before taking up the subject of color harmony, it is necessary for the student to know something of the nature of color in its abstract sense. That is to say, he must learn, first, to consider color as a natural sensation in the same way that he comprehends the sensation of heat and of cold. When we consider that we have five senses—the senses of sight, of hearing, of touch or feeling, of taste, and of smell—we must understand that there is no sensation outside of our individual selves. To make this clearer, let us take an example. We all know that the sense of hearing, or the sensation of sound, is due to the vibration of the drum of the ear and that where there is no ear present to receive these vibrations that are transmitted through the air there is no existing sound.

In a similar manner, we can study the sensation of light. The effect of light is produced by the vibration of what are usually termed **light waves**, and these vibrations affect the retina of the eye to produce the sensation of light somewhat after the manner that the vibrations of the air affect the drum of the ear and produce the sensation of sound.

**2. Standard of Light.**—The scientific theory of light does not concern us in this subject of color harmony, except so far as an analysis of light gives us the phenomena of color. It must be borne in mind that we must have a

*For notice of copyright, see page immediately following the title page*



standard of some kind to go by at all times, and if we take clear sunlight as a standard and call that *white* light, we have a standard with which we can make comparisons.

**3. Shadow.**—Shadow is produced by varying the degree of light. If an object is equally illuminated on all sides it possesses no shadow, but where the light falls upon it from one direction some parts of it are illuminated more than others and the object, if opaque, interferes with the passage of light and casts a shadow. Shadows vary in degree from a slight diminution of the power of the direct light to utter darkness.

**4. Relation of Light and Shadow.**—The relation of light and shadow to color is a very important one, and it must be borne in mind that color is a sensation produced by certain conditions of light and outside of those conditions does not exist at all. To make this clearer, let us assume that we have a red card hanging in a room. Now, as long as that room is illuminated, no matter in how slight a degree, the card remains red, but as soon as the room is in utter darkness the card is no longer red because the sensation of the red color is produced by the reflection of the light from it, and if there is no light to reflect, there is no color there.

**5. Analysis of White Light.**—An analysis of white light will show that it is composed of a combination of seven separate colors, violet, indigo, blue, green, yellow, orange, and red. These colors vary in quantity to form white light, and colored lights can be mixed in such proportions that they will produce white light. An illustration of the analysis and decomposition of light may be seen in the rainbow, where the sunlight passing through drops of rain is refracted and broken up into its several colors. A more satisfactory decomposition of light can be obtained by means of a glass prism, when the colors appear much clearer.

**6. Artificial Color.**—The only method that we have of producing the sensation of color with any degree of

permanency is by means of pigments or dyes. If we stain a piece of paper or fabric with a certain dye, or if we paint on its surface with a pigment, we produce on that paper the sensation of a given color. This is due to the fact that the pigment or dye has the mechanical or chemical quality of absorbing all the color rays that compose the white light except the particular color that it reflects back to the eye, and thus produces that sensation. If we paint on the paper with red and set it in the light, we know that the pigment is absorbing the violet, indigo, blue, green, yellow, and orange rays and is reflecting back to the eye only the red, hence, the sensation of red.

---

#### PRIMARY COLORS.

**7. The Spectrum.**—The seven colors mentioned above are called the **spectrum**, which varies with different kinds of light, such as sunlight, gaslight, lamplight, etc. That is to say, that the seven colors composing them vary in proportion, but are constant for the same kind of light. It is found that green, violet, and orange can be produced by the mixture of other colors, and if we subtract these from our spectrum, as well as the indigo of which we will learn more later on, we will reduce our colors to three—red, yellow, and blue. These three colors are termed the **primary colors**, inasmuch as they cannot be divided into any other colors and exist by themselves as a standard from which all other colors and shades can be theoretically made. Red and yellow make orange, blue and yellow make green, red and blue make violet.

**8. Formation of Colors of Spectrum.**—Now, it may be assumed that when we paint on a card or surface with green paint, that card absorbs all the colors of the spectrum, except the yellow and the blue and these it reflects to the eye, producing the sensation of green. The proportion of each of these colors, yellow and blue, that is reflected will determine the quality of the green that appears on the surface. For practical purposes it can be assumed that the

colors of the spectrum are really red, yellow, and blue, and that the colors orange, green, and violet consist of an admixture of the adjacent colors, inasmuch as the orange occurs between the red and yellow and the green between the yellow and blue. Therefore, we will confine our studies to these three colors for the present.

**9.** The ancients seemed to possess a very practical idea of these colors and their harmony with one another, inasmuch as all the earliest, and from an artistic standpoint, highest quality, of ornament and decoration were executed in the three primary colors, and the secondary, or mixed, colors were not introduced until the art of the various periods began to decline.

---

#### SECONDARY COLORS.

**10.** The secondary colors are green, orange, and violet and they vary in shade or tint according to the proportion of the admixture of the two colors composing them, whereas the primary colors are standard and do not vary. A mixture of two secondary colors gives us what we term a **tertiary** color, or one composed of four primaries. This may seem somewhat obscure at first, inasmuch as we have but three primaries, but in a tertiary color some one of the primaries must exist twice. If we mix green and orange we will get a brown tint in which there is nearly twice as much yellow as there is of either of the other primaries, and while it contains nothing but the three primary colors we call it a tertiary color because it is in reality composed of four ingredients.

---

#### POSITION OF COLORS IN CHROMATIC SCALE.

**11. Blue and Yellow.**—Of the three primary colors blue possesses that quality that is technically known as "coldness" in color, and if we adopt a chromatic scale, that is, a color scale, wherein the various colors are related to one another in the same manner that the various degrees of light and shade are related to one another from most

brilliant sunlight to absolute darkness, we will find that blue in the color scale will be nearest black or darkness. That is to say, that blue is the least obtrusive of all the colors, and when used in a design or decoration is the least conspicuous. Blue bears exactly the same relation to absolute darkness or black that yellow does to brilliant light or white. The palest shade of yellow is nearly white; the darkest shade of blue (indigo) is nearly black.

**12. Red.**—Yellow and blue, then, will occupy the extreme ends of our color scale, and all other colors will be arranged between them in the order of their brilliancy or obtrusiveness. Red, therefore, will stand between these two extremities; in other words, red is intermediate between black and white or between light and shade. Hence, red has a double power in its mixtures, for by union or mixture with yellow it becomes a warm and conspicuous color, but combined with blue it recedes and becomes colder and retiring. It is preeminent with all colors, forming with yellow the secondary color orange and its close relatives scarlet, etc., and with blue the secondary purple with its allies violet, crimson, etc. It gives warmth to all colors but particularly to those that already possess a proportion of yellow to some degree.

**13. Orange.**—Of the secondary colors the first in relation to light and warmth is orange. Such a compound of red and yellow as will, in an equal quantity of either surface or intensity, neutralize a perfect blue is termed a *perfect orange*. By **neutralize** is meant to offset completely in intensity or prominence. The proportions of such a compound are very important and consist of five parts of perfect red and three parts of perfect yellow. An increase of red causes the color to approach scarlet; an increase of yellow causes it to approach a lemon yellow. A mixture of orange with green forms the tertiary color called citrine, and with purple it produces russet. By degrading its brilliancy with black it forms what are termed **semineutral** colors, which we will discuss hereafter.

**14. Green.**—Green in the general scale of colors, so far as relation of light and shade are concerned, occupies the middle position, but in the secondary colors it is second. It is composed of the extreme primaries yellow and blue. A *perfect green* consists of three parts of yellow and eight parts of blue in equal intensities and this perfect green will neutralize a perfect red in the proportion of 11 : 5. Of all compound colors green is the most effective, distinct, and striking, and contrasts beautifully with the other primaries and secondaries and is the most abundant color found in nature. Mixed with orange it produces the tertiary citrine, and mixed with purple it produces the other extreme of tertiary, olive.

**15. Purple.**—Purple, the third and last of the secondary colors, is composed of five parts of red and eight parts of blue. Such a purple will neutralize a perfect yellow in the proportion of 13 : 3. As said before, with green it produces olive, and with the other tertiary, orange, produces russet. It is the coldest of the secondary colors and nearest black in respect to light and shade. It is a receding color and possesses many of the qualities of blue in this respect. Next to green, purple is the most pleasing of the contrasting colors. It has long been emblematic of royalty, probably on account of its rareness in a pure state in nature. Purple when inclined to red takes the name of crimson, and falling back toward blue becomes violet.

**16.** These six colors constitute the entire gamut or chromatic scale with which all tints and shades are represented. As said before, mixed with black they form semi-neutral tints. If we consider a color scale beginning with the palest yellow and ending in the darkest blue, we have the extremes of light and shade producible by pure color. On the other hand, if we have a parallel scale beginning with the purest white and ending in the deepest black, we have the extremes of light and shade producible with all the colors, or in other words, producible with white light.

## NEUTRAL TINTS.

**17. Formation.**—In nature we have several neutral tints that are produced by reducing the intensity of light on the color. It may be that the object that presents a neutral tint to the eye does so by absorbing the seven colors of the spectrum to a certain extent and reflecting only a small portion of the ingredients necessary to give it its tint. This has the same effect on the eye as though the object were in shadow. If we take a tree trunk the bark of which is brown, we can assume that only a portion of the red, yellow, and blue constituting that color is reflected, and that it is in reality the same as the tertiary color russet in deep shadow.

**18. Use of Black.**—As black is our means of producing the effect of shadow, we can produce the semineutral colors by mixing black with the secondary and tertiary colors. By doing this, we simply are mixing shade with them and in this way get a new series in the scale of color compounds, having black for its basis. These same neutral tints are termed brown, maroon, and gray. They are far inferior in point of color to any of the primaries or their direct combinations, but they are of the greatest value inasmuch as they exist in nature in so large a proportion that they serve as a background against which the more brilliant colors contrast.

## PRODUCING HARMONY.

**19. Necessary Proportions of Colors.**—In decorative effects all colors must be mixed so as to neutralize one another, and reducing all colors to the perfect primaries, we find that where these three colors exist they should be in the proportion of three parts of yellow, five parts of red, and eight parts of blue. It will be remembered that yellow is the warmest of the colors and blue the coldest and that red lies intermediate between them. It will be evident from the above proportion, too, that on a given surface it requires

as much blue as there is red and yellow combined to produce harmony.

**20. Importance of Proper Proportions.**—These figures are of vast importance in color harmony, although in general practice it is not possible to mix them in these absolute proportions, but it is possible to train the eye so as to appreciate proportions when the color appears on a surface. If we have a figure or a decoration on which it is desired to express three colors, it can be divided according to the area of its several parts and the three colors laid in the proportion of three parts of yellow, five parts of red, and eight parts of blue, thus producing harmony. Or, if there are but two colors, such as red and green, the green should be such a mixture of blue and yellow as will give us the necessary contrasting color with red. The aim should be at all times to keep this mathematical proportion and to vary the tint or intensity of one of the colors in order that it will harmonize with the other two.

**21.** It will be remembered that the Moors in decorating their walls with the elaborate geometrical color devices characteristic of their art practiced this color harmony with the greatest of skill. They reduced the quantity and intensity of red in their decorations, because yellow was replaced by gold leaf and the gold leaf had a reddish tinge. In the same way, the modern artist, where he uses a combination of a primary and a secondary color or of two secondary colors, reduces those colors as nearly as possible so that in the entire general surface of the decoration there will be the proper relation of 3, 5, and 8 in the yellow, red, and blue. There are many ways of accomplishing this, and it depends in each case on the design to be executed as to how it can be best carried out.

**22.** The student first studying the subject of design practices "spotting" or "space relation" by dividing up surfaces in order that he may become skilled in judging the amount of light and shade that is required to produce the

most pleasing effect. When he advances to color work he must bear in mind the spotting, inasmuch as a red figure on a green ground has the effect of a spot, but the shade of his red and the quality of his green must also be considered, in order that the entire surface covered will be harmonious in the admixture of his color.

#### MAKING A COLOR CARD.

**23.** In order to appreciate this proportion, the student should draw on a sheet of paper a number of small squares, each about  $\frac{1}{8}$  or  $\frac{1}{4}$  of an inch on the sides, as shown in Fig. 1, and then paint in his three colors, yellow, red, and blue, and

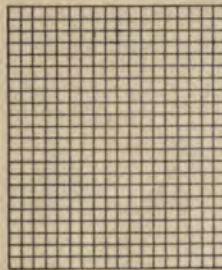

FIG. 1.

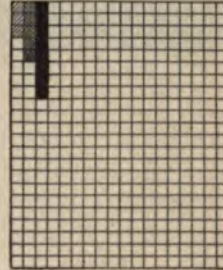

FIG. 2.

streak or stripe over each set of squares so that the relative proportion of 3, 5, and 8 of each color is maintained, as shown in Fig. 2. In this way he will associate in his mind the relative value of each color to the other.

He should then construct three squares similar to Fig. 3 that bear the same relations to one another that the three lines do in Fig. 2. This can be done approximately; by making the middle square  $1\frac{3}{8}$  inches on each side, he will give it an area of very nearly 3 square inches. The next square should be  $2\frac{7}{8}$  inches on each side, in order that its entire area may be 8 square inches, and the circumscribed area around the center square should be 5 square inches. The extreme outside square must be 8 square inches larger than the one within, or 16 square inches in all, and 4 inches on each side



will fulfil this condition. The outside square being painted blue, the middle square red, and the inner square yellow, will then present the colors in their relative proportions.

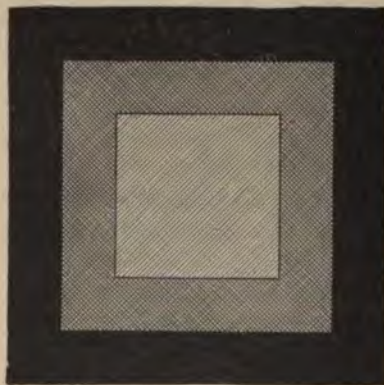

FIG. 3

Three concentric circles whose diameters are  $4\frac{1}{2}$  inches,  $3\frac{2}{10}$  inches, and 2 inches will give us the same proportions.

**24.** A number of figures can be constructed on this basis, where the colors interlock more so as to distribute the different colors in smaller quantities and at the same time preserve their relative proportions.

For instance, let us assume that we have a wall decoration where the repeat is 18 inches square, and the ground color consists of a perfect red, while the figure consists of a vine whose color is formed by a mixture of three parts yellow and eight parts blue. In such a pattern the area of the vine should be not less than  $\frac{11}{16}$  of the entire repeat and the background  $\frac{5}{16}$ —so that the relation will be 11 to 5. In other words, the entire area of the repeat being 324 square inches, the vine should occupy a little more than 220 square inches and the ground about 100 square inches. Or if the background were blue and the design upon it were executed in orange, an equality of area could exist between the figure and the background in order to preserve the relation of three parts yellow, five parts red, and eight parts blue in the design. Constant practice on figures that will show this color relation is of the greatest value and utmost importance.

**25. Contrast of Colors.**—After painting the colors in their relative values several times, the student should hold the paper at a distance and become accustomed to all the

THE NEW YORK  
PUBLIC LIBRARY  
ASTOR LENOX  
TILDEN FOUNDATIONS



Fig. 1.



Fig. 2.



Fig. 3.



Fig. 4.

Hi  
O



Fig. 6.

Present



Fig. 7



Fig. 8.



Fig. 9.

THE NEW YORK  
PUBLIC LIBRARY  
ASTOR LENOX  
TILDEN FOUNDATIONS

colors when properly blended, and then he should make similar attempts at coloring by contrasting red and green, blue and orange, yellow and purple, etc., using the secondary colors in as nearly their proper mixtures as he can make them. With liquid colors it is a difficult thing to exactly mix any two colors in any exact proportions, but with powdered colors a given quantity of each can easily be measured and the two mixed together to form a desired tint. However, this is not necessary in practice, as the trained eye is of more value than any mechanical arrangement.

**DRAWING PLATE, TITLE: HISTORIC ORNAMENT.**

**26.** With this understanding of the relative values of colors, we again take up the subject of *Historic Ornament* and execute Plate 1 with these ideas in mind. There is nothing on this drawing plate with which the student is not already familiar, each of the figures having been illustrated in *Historic Ornament*, and being reproduced only to show the effect of color and to give the student practice in same.

The finished drawing plate is to be 13 in.  $\times$  17 in., inside the border line, the same as the previous plates, and the figures

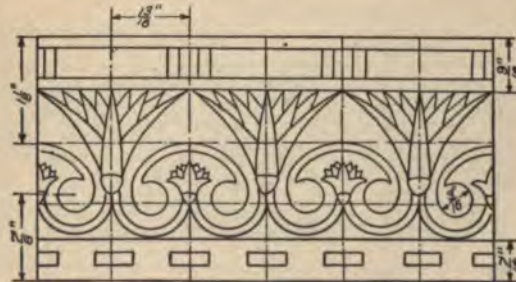

FIG. 4.

must be enlarged to give that proportion. Figs. 1, 2, 3, and 4 are each  $4\frac{3}{8}$  inches in length and  $2\frac{1}{8}$  inches in width, as

shown in Figs. 4, 5, 6, and 7, of the text. Figs. 5, 6, and 7, of the drawing plate, are  $2\frac{9}{16}$  inches in width and  $5\frac{1}{8}$  inches

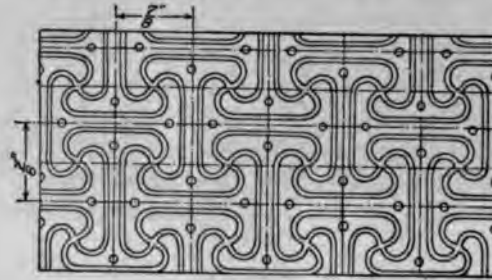

FIG. 5.

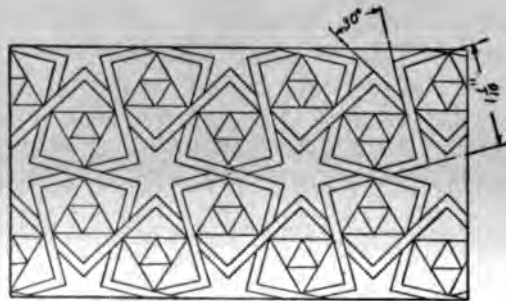

FIG. 6.

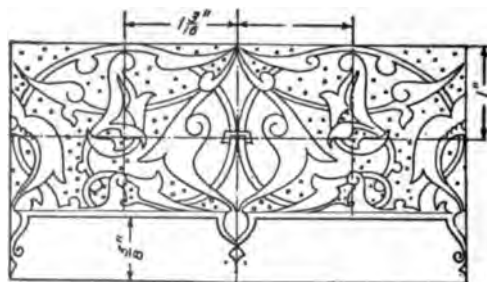

FIG. 7.

in length. Figs. 8 and 9 are  $4\frac{3}{8}$  inches in width and of a height corresponding to the neighboring figures, as shown.

The location and proportion of the individual parts are shown in Figs. 8, 9, and 10, of the text, while Figs. 4, 5, 6, and 7,

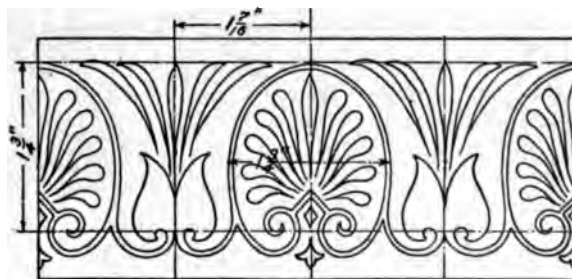

FIG. 8.

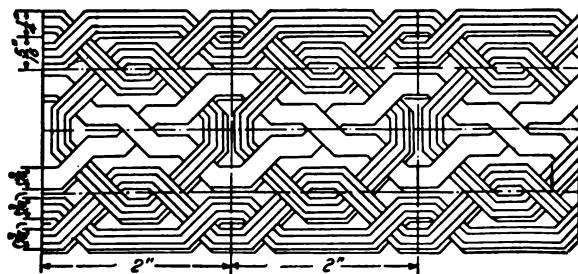

FIG. 9.

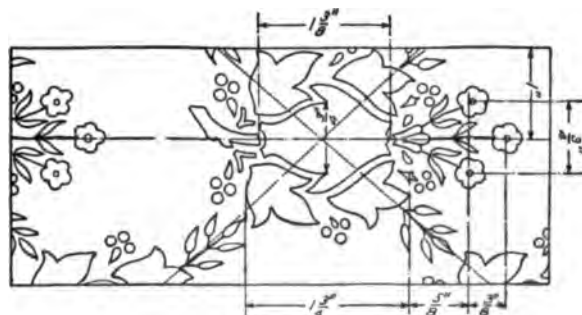

FIG. 10.

of the text, are the outlines of Figs. 1, 2, 3, and 4, of the drawing plate.



**27.** The student will construct these figures in pencil without any further directions, and Figs. 1, 2, 3, and 4 may then be outlined, in waterproof ink, but with a very fine line, as shown on the drawing plate. Figs. 5 and 7 should be sketched in pencil, but not outlined in ink. Figs. 6 and 8 should be carefully drawn in pencil and inked in, but Fig. 9 should not be inked in, except around the gold portion, until all the color work is finished. All inking in should be done with the T square and ruling pen, where possible, and the greatest care should be used to see that the drawing is as perfect as possible before the work of coloring is commenced.

**28.** In applying color to this plate, the student should match the original tint as closely as possible, and in order to do this it will be necessary for the color to dry on a sample piece of paper, which he can lay over the original and determine the degree or intensity of his shade.

**29.** The background of Fig. 1 is a creamy tint produced by a very thin wash of yellow orange—so light, in fact, is this tint that the other colors may be applied on top of it without its materially affecting them. The reds produced in Figs. 1 and 2 are formed with a slight addition of yellow to the pure red color. The tint is what is usually termed red orange and is of a class of red orange bordering on red; that is to say, there is an excessive red in it, making it approach the scarlet in hue. The student should mix his color and try it on a separate piece of paper, permitting it to dry, and then compare it with the original by laying his colored paper alongside of the original for comparison. The yellow in Fig. 1 is pure yellow and may be painted directly, without any admixture, care being taken that it is mixed in good body so as not to appear too pale. The blue in Figs. 1 and 2 is a greenish blue and is produced by mixing with pure blue a very slight suggestion of yellow, and applying the color in a thin wash. The green is a yellow green produced by mixing a thin wash of blue with a rather strong

wash of yellow. The central portions of the red and blue figures in Fig. 2, being shaded slightly, appear darker than the body of the figures, and this shaded effect may be produced by a very slight wash of a weak solution of black.

**30.** The principal difficulty in Fig. 3 lies in its geometrical construction rather than in its coloring. This construction, however, can easily be worked out by reference to Fig. 6, of the text. The red in Fig. 3 is produced by the addition of a trifle more yellow than was used in Figs. 1 and 2, but the yellow in Fig. 3 is a pure yellow, and the black absolute in color, which makes it easily applied.

**31.** In drawing Fig. 4, the blue background should be painted first with a shade of blue to which the slightest suggestion of yellow has been added to give it a greenish tinge, but the addition of this yellow must be almost imperceptible, producing a blue precisely similar to that shown in Fig. 2, but darker in color. Two or three washes of the blue in Fig. 2 should produce a blue such as shown in Fig. 4—one being a light, and the other a dark tint of the same color. The red is the same as that in Fig. 3. The green of Fig. 4 is a light yellow green produced by adding, gradually, small quantities of blue to a rather pale wash of yellow. The light tint forming the background at the bottom of Fig. 4 is a light orange in a very pale wash, produced by adding the slightest suggestion of red to a thin wash of yellow.

After these colors are all washed on, the student should apply his gold in precisely the same manner as his color, being careful to get it thick enough to cover the white background and appear opaque. The outlines of certain figures may then be emphasized by means of a pen charged with black ink, and the black portions of the design inked in with waterproof ink, while the white spots in the various portions may be produced by means of Chinese white.

**32.** In drawing Fig. 5, it will be found best to wash in the entire rectangle with the orange background color, as shown, and then to lay the other colors over it. This

background is composed of the same ingredients as the lower part of Fig. 4, but is slightly darker. In any case, do not get it any darker than is shown on the original drawing plate, as it will be less of an error to make it lighter than to make it darker. The red in the strokes of the Greek ornament is very nearly a pure red, but it has a slight addition of yellow, bringing it toward the scarlet, but the student should bear in mind that the orange background already contains some yellow and this will affect the color. Experiments should be made with this on a separate piece of paper before these strokes are put in. The blue is a greenish blue produced with the slightest suggestion of a yellow admixture. The outlines of the details of this figure should be drawn sufficiently strong in pencil, so that when the background wash is put on they will show clearly and enable the student to follow them closely.

**33.** Fig. 6 is a Moorish design constructed on geometrical lines, as shown in Fig. 9, of the text. Its three colors—red, gold, and blue—are very nearly pure colors, although the blue contains a slight suggestion of yellow carrying it somewhat toward the green, but not as much yellow, even, as the blue in Fig. 5. Yellow is also added to the red, inasmuch as the gold, which takes the place of yellow in this design, is of a reddish tinge, and the addition of yellow to the red background produces a harmonious effect.

**34.** Fig. 7 is a Gothic design wherein the background is composed of two shades of an orange red. The color should be mixed to the lighter tint and washed rapidly and evenly over the background throughout all portions except where the green exists. While the paper is still wet, the darker portion should be washed in so that it will cloud away into the ground and will not show any distinct or sharp outline. The green is a yellow green produced by the addition of blue to a medium wash of yellow and should be applied in as even a tint as possible so as to show a sharp, clear outline and contrast with the red background. The white flowers may be put in with Chinese white after the ground is dry,

as well as the yellow blossoms by means of Chinese white tinted with pure yellow or a light orange.

**35.** The essential characteristic in Fig. 8, which is a Byzantine design, is the background, as the Byzantine blue is a very difficult shade to produce. It is a greenish blue, but depends for its quality not only on the quantity of yellow that is mixed with the blue to give it the greenish tinge, but also on the thickness of the wash. The student should make repeated trials of this color on separate pieces of paper

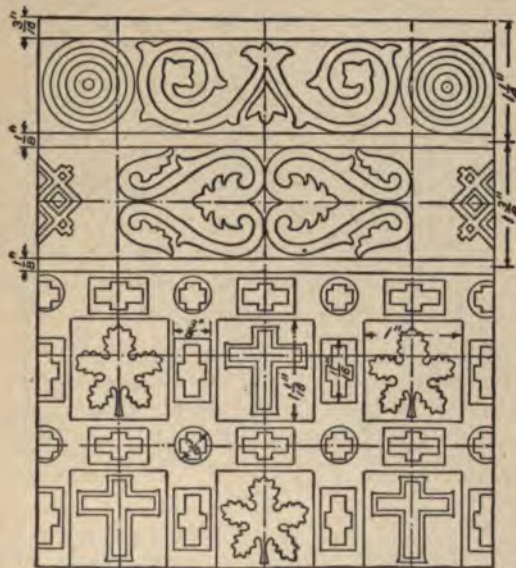

FIG. 11.

until the desired tint is obtained. The green of the leaves, and the upper part of the design, may be carried out with the same color as was used for Fig. 7, and the red is the same red that was used in Fig. 3. The last color to be applied should be the gold, and care should be taken that this does not overreach on any of the color work so as to impair the quality of the outlines. The dimensions for outlining Fig. 8 will be found on Fig. 11, of the text.

**36.** Fig. 9 is a Gothic design taken from a stained-glass window, and although the general dimensions are given in Fig. 12, of the text, the student must lay out the greater part of it freehand. The background of the figure is the same as in Fig. 1. There are several shades of red, blue, orange, and green in this figure, and care should be taken



FIG. 12.

to represent each color with a separate wash as simple as possible. Mix the red and blue to the proper tints first and then paint in the red portions of the design. Both of these colors will require a slight addition of yellow to give them the proper tinge, as neither of them is absolutely pure. The green is a yellow green and therefore should be produced by the mixture of an excess of yellow in the color.

**37.** In working with water color the student will find that he depends very largely on the white drawing paper

showing through the color to produce a desired effect. A thin wash of color will produce a light shade of that color, because the white of the paper shows through, and therefore in a drawing similar to Fig. 9 the skilful designer frequently lays the color on rather heavily and while it is still wet removes portions of it in different places to diminish the strength of the coating and permit the white paper to show through, thus giving the effect of lighter tints. This removal is accomplished by wiping the brush nearly dry and applying it in little touches here and there where it is desired to have the color removed. The surplus color will run up into the hairs of the brush, but can be wiped out of it from time to time. In a similar manner, the practical designer frequently produces effects of shadow or shaded backgrounds, such as is shown in Figs. 2 and 7, by darkening certain portions of the paper with color before any part of the design is colored in. The slightly shaded effect at the center of the red and blue figures in Fig. 2, and the clouded background in Fig. 7 can be produced by painting in the darker portions on the white paper before the figure itself is washed in. An even tint of color is then washed over the entire surface, and the light color shows where the white paper reflects through most strongly, and the darker tints are produced where the paper surface has been stained or colored purposely.

**38.** The title on this drawing plate is in the Old English alphabet, and the student may draw the same between two pairs of horizontal lines spaced  $\frac{1}{2}$  inch apart to limit the top and the bottom of the letters. The upper one of this set of horizontal lines should be  $1\frac{1}{4}$  inches below the border line, and the two lines of letters should be spaced  $\frac{1}{2}$  inch apart. The letters are colored with the same tint of red as is shown in Fig. 1, and the device in the background is of the same tint of blue as was used in Fig. 8. Where the letters reach over on the blue background figure they should be outlined with a fine line of Chinese white, and the letters themselves should be outlined with waterproof black ink before any

coloring is done. After inking in the border line, the student should place his name and class number and letter



FIG. 18

in the lower right-hand corner of his plate, and the date in the lower left-hand corner, as usual.

11-11-11





Fig. 1.



Fig. 2.



Fig. 3.



Fig. 4.



# FORMS



Fig. 6.



Fig. 7.



Fig. 8.



Fig. 9.

THE NEW YORK  
PUBLIC LIBRARY

ASTOR, LENOX  
TILDEN FOUNDATIONS

**DRAWING PLATE, TITLE: NATURAL FORMS.**

**39.** The figures on this plate, with few exceptions, are very similar to figures already executed by the student in his freehand drawing exercises; therefore, it will be unnecessary to particularize concerning the details of the drawing itself. The central panel represents a pattern for wall paper executed on the principle demonstrated in *Freehand Drawing* on Drawing Plate, title, Applied Design.

In executing the figures on this colored plate, the student should begin with the central panel. Draw it according to the dimensions in Fig. 13, of the text, and locate it, in the middle of the plate horizontally with its top line  $1\frac{1}{4}$  inches below the upper border line. The other figures may then be located on the spaces to the right and left of the central panel according to the measurements given in the text cuts.

**40.** Having carefully drawn all the details and having located each leaf and petal in pencil on the central panel so that the relation of figure and background is properly defined, the student may proceed, with Fig. 1, according to the measurements shown in Fig. 14 and color it as follows: The petals of the geometrical delineation of the daisy are painted in even tints of a yellow orange, while the center is a dark brown obtained by mixing all of the colors in the following order. First, obtain a purple by the mixing of

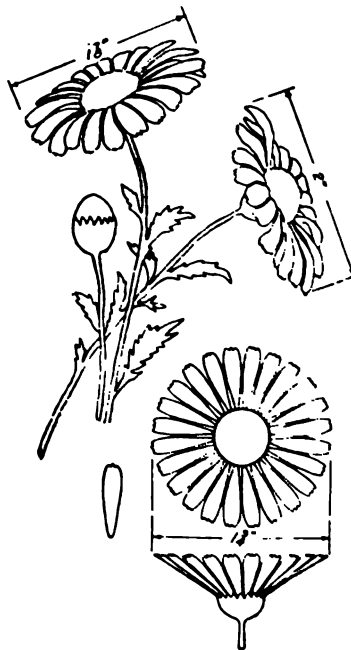

FIG. 14.

the red and blue, then, a rather dark orange by the mixture of the red and yellow. When the purple and orange are combined they will form a brown that may be tempered with one color or the other to bring it up to the proper tint. The naturalistic rendering of the same flower above may be colored with the same tints, and the shading effected by laying the tint heavier over the darker portions, the effect of light and shade being produced by the transparency of the color showing the light paper from beneath.

**41.** Fig. 3 is shown in outline in Fig. 15, of the text. This figure shows the colored rendering of the single carnation drawn in pencil heretofore, and the tint of the petals may

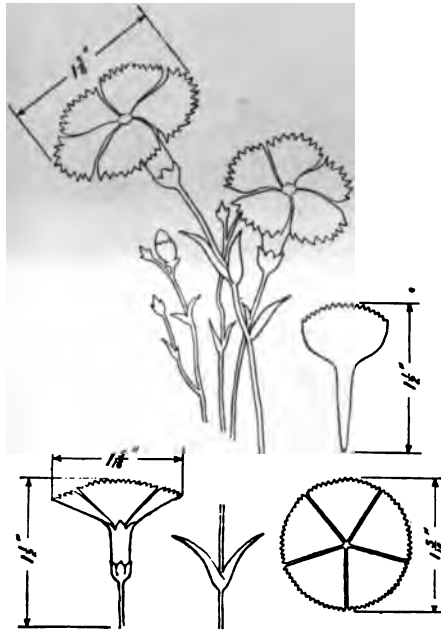

FIG. 15.

be obtained by means of a very light wash of the red. It may be here pointed out that the term pink, which is the color of these petals, usually refers to a mixture of red and white, but in water-color work we depend on the transparency of the color to show the white paper through the pink in order to produce the desired effect. In opaque color, of which we will have occasion to speak hereafter, pink is obtained by mixing the white pigment directly with the red color. The

tints in Figs. 3 and 4 are precisely the same, except that the shaded proportions of Fig. 3 are produced by laying the color heavier on these parts while the wash on the petal is

still wet, thus causing it to shade in and blend itself into the general tint. Details *a*, *b*, *c*, and *d* of Fig. 4 should be washed in in absolutely flat tints corresponding to the body tints in Fig. 3.

**42.** Fig. 6, the dimensions of which are shown in Fig. 16, is rather more difficult to render; the principal color, however, is a yellow orange, which can be obtained by making up a wash of yellow and mixing with it the slightest suggestion of red. The dark portions of the wings of the insect may be put in with rather a heavy wash of brown mixed in the same manner as the brown for Fig. 1. Or, if unsatisfactory results are obtained from this method, a wash of black, or India ink may be introduced, although the latter method is entirely unnecessary as a very dark brown may be obtained by mixing the three colors liberally and permitting the blue to dominate. The blue spots in the lower portions of the wings may be produced by laying a wash of blue over the yellow that already forms the body wash of the figure, the spots being

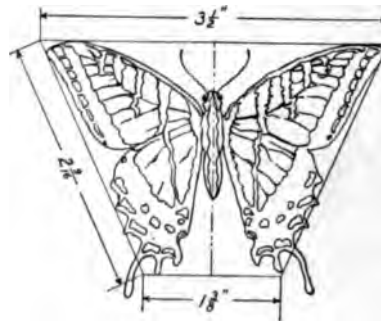

FIG. 16.

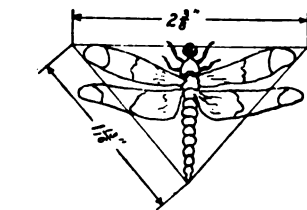

FIG. 17.

a greenish blue, and the wash of pure blue on top of the yellow being sufficient to produce the desired tint.

**43.** In Fig. 7 we have a dragon fly whose outline is shown in Fig. 17. Its color is a blue green composed of a mixture of yellow and blue in proportions that can be best determined by experiment. The shaded portions of the wings are produced by the addition of a brown wash

mixed as for the shading of Fig. 6 but much lighter in its consistency.

44. With Fig. 8 much difficulty is likely to be experienced unless great care is taken. All the details should be carefully drawn in pencil according to measurements given in Fig. 18, and then the dark portions of the figure shaded in with a wash of brown mixed precisely in the same manner as for Fig. 6. This wash will form the top of the head, the ends of the mouth, the shade along the back and into the ribs of the fins, and also the small crescents suggesting

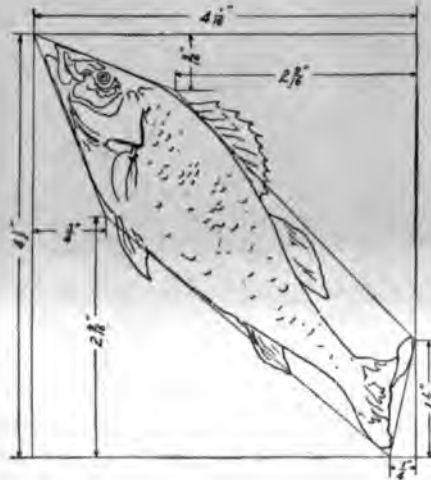

FIG. 18.

the shape and position of the scales. In the last case, however, the wash should be very thin in order not to be too prominent. The entire figure may then be washed over with a light orange tint similar to the orange used in Fig. 6. The green tint along the back and under the fin may be laid while this orange wash is still wet, by overlaying a wash of purple to

which a little yellow may be added to preserve the green. The fin itself is of a green color but possessing much less yellow, and may be formed by adding a little blue to the tint already obtained along the back. The under side of the fish, exclusive of the fins, may be tinted with a light wash of purple, allowing it to run up on the side so as to form the two or three alternate stripes of yellow, as shown. The salmon color that tints a portion of the sides and the lower fins is obtained by laying a thin coat of orange shaded

slightly with pure red. Experiment with these colors and comparison with the original drawing will indicate to the student the simplicity with which these details will be carried out.

**45.** Fig. 9 consists apparently of three colors, but in reality of only two. The brown mixed for Fig. 6 may be used with an addition of blue to form the black of the upper portion of the wings. The red is obtained by adding to a thin wash of this same brown a considerable quantity of plain red and tempering it with yellow to bring it to the proper tint, while the brown in the lower wings consists of a thin

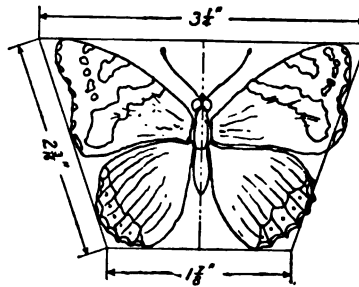

FIG. 19.

wash of the same brown to which some blue has been added with enough yellow to produce the particular tint. The outline of this figure is shown in Fig. 19.

**46.** It will be evident to the student that all these figures must be drawn separately and experimented on before he attempts his drawing plate, and in Figs. 1 to 4 both the geometrical and the natural rendering of the forms have been given in order that the flat tints may be applied to the former to secure the color and the shaded tints to the latter to secure the effect. In Figs. 6 to 9, the student has worked over a flat tint in each case, the whole figure being laid out in an even tone and the shading put in afterwards. This is the principle on which he should work for all water-color drawing. If he is desirous of rendering in water color some natural form that has not come under his notice in these studies, he should go back to the principles given in *Frechand Drawing* to make the first pencil sketch. He can then analyze this form and put it in a geometrical position and color it with flat tints. He can then proceed with his



natural rendering and shading, as illustrated here. A principle that applies to one thing applies to all, and there should be no more difficulty in rendering the naturalistic drawing of a rose or chrysanthemum than in these simple forms here, after the student has applied the principles he has studied and has endeavored to put them into practice.

**47.** In drawing Fig. 5, the student will adapt to the conditions of repeating ornament a natural form and work its rendering under the limitations of the wall-paper printing machine. In this work the background represents the color of the paper itself, and every tint or shade, as well as every separate color, must represent an additional pigment in the printing of the figure. In this figure there are five colors, practically, besides the background, although theoretically there are but two—green and red—but inasmuch as the student is working for practical purposes he will, after drawing this figure in pencil outline, render it with five separate colors mixed as follows: The background consists of the lightest possible wash of a salmon pink, composed of orange to which a little red has been added, so that when applied over the white paper the effect of pink with a yellowish tinge is obtained. While this is drying, the student may mix two shades of green and two shades of red with a sufficient quantity of Chinese white to produce an opaque pigment. The amount of color can be determined only by experiment. The amount of Chinese white should be sufficient to render the applied color absolutely opaque and no more, and should be of a similar consistency with the color on previous plates that were rendered in black-and-white only, where the darker portions were mixed with Chinese white to give them body.

In this figure the student can use pure red for the darker color of the chrysanthemum and mix it until the color remains the full depth when dry. This same color, with the addition of a little yellow and more Chinese white, will form the lighter tint of red. The light green is formed in the same manner by mixing the desired tint of green with

Chinese white until, after application, it dries out to the lighter tint shown on the drawing plate. Then, a darker tint of green should be mixed by adding more color and a slight suggestion of brown in order to produce the shadow.

**48.** The whole drawing may now be colored in with the lighter tints of mixed colors, each petal of the chrysanthemum being made by means of a single stroke of the brush charged with the lighter color of red. The green leaves should be washed in with the green, the point of each leaf lobe being the subject of one brush stroke and all brought together in the middle and painted down until they reach the stem. After this is dry, the darker colors may be touched on, as shown, to produce the shaded effect, but the brushes should be washed out so that there will be no contamination of tints or colors, and the darker color may be painted over the lighter. The veining of the leaves and the shading of the stems may be effected with the same dark color of red as was used for the shading of the petals of the chrysanthemum.

**49.** If, in mixing these colors, there is any tendency for them to powder or scale off, the addition of a few drops of gum arabic or mucilage to the mixed color will prevent the difficulty and bind the colors together. Chinese white is sometimes called zinc white, and is in reality an oxide of zinc. This zinc oxide can be purchased in powdered form at any paint store, and mixed up to form the white that may afterwards be used for body color, as follows: First, shake it up in a bottle with a large quantity of water until it is thoroughly mixed, then stand the bottle aside for several days until all the zinc white has settled to the bottom. The clear water on top of the pasty mass should then be poured off and a small quantity of glue or mucilage added in order to hold the particles together after it is applied to any surface. This white paste may then be mixed with water colors or powdered colors, such as are used for fresco work, and will in every way fulfil the requirements demanded in these exercises.

1

2

3

4



Vertical line of text, possibly a page number or header.









