



This is a digital copy of a book that was preserved for generations on library shelves before it was carefully scanned by Google as part of a project to make the world's books discoverable online.

It has survived long enough for the copyright to expire and the book to enter the public domain. A public domain book is one that was never subject to copyright or whose legal copyright term has expired. Whether a book is in the public domain may vary country to country. Public domain books are our gateways to the past, representing a wealth of history, culture and knowledge that's often difficult to discover.

Marks, notations and other marginalia present in the original volume will appear in this file - a reminder of this book's long journey from the publisher to a library and finally to you.

### **Usage guidelines**

Google is proud to partner with libraries to digitize public domain materials and make them widely accessible. Public domain books belong to the public and we are merely their custodians. Nevertheless, this work is expensive, so in order to keep providing this resource, we have taken steps to prevent abuse by commercial parties, including placing technical restrictions on automated querying.

We also ask that you:

- + *Make non-commercial use of the files* We designed Google Book Search for use by individuals, and we request that you use these files for personal, non-commercial purposes.
- + *Refrain from automated querying* Do not send automated queries of any sort to Google's system: If you are conducting research on machine translation, optical character recognition or other areas where access to a large amount of text is helpful, please contact us. We encourage the use of public domain materials for these purposes and may be able to help.
- + *Maintain attribution* The Google "watermark" you see on each file is essential for informing people about this project and helping them find additional materials through Google Book Search. Please do not remove it.
- + *Keep it legal* Whatever your use, remember that you are responsible for ensuring that what you are doing is legal. Do not assume that just because we believe a book is in the public domain for users in the United States, that the work is also in the public domain for users in other countries. Whether a book is still in copyright varies from country to country, and we can't offer guidance on whether any specific use of any specific book is allowed. Please do not assume that a book's appearance in Google Book Search means it can be used in any manner anywhere in the world. Copyright infringement liability can be quite severe.

### **About Google Book Search**

Google's mission is to organize the world's information and to make it universally accessible and useful. Google Book Search helps readers discover the world's books while helping authors and publishers reach new audiences. You can search through the full text of this book on the web at <http://books.google.com/>

B 427570



THE GIFT OF  
Mrs. J. H. Dietz

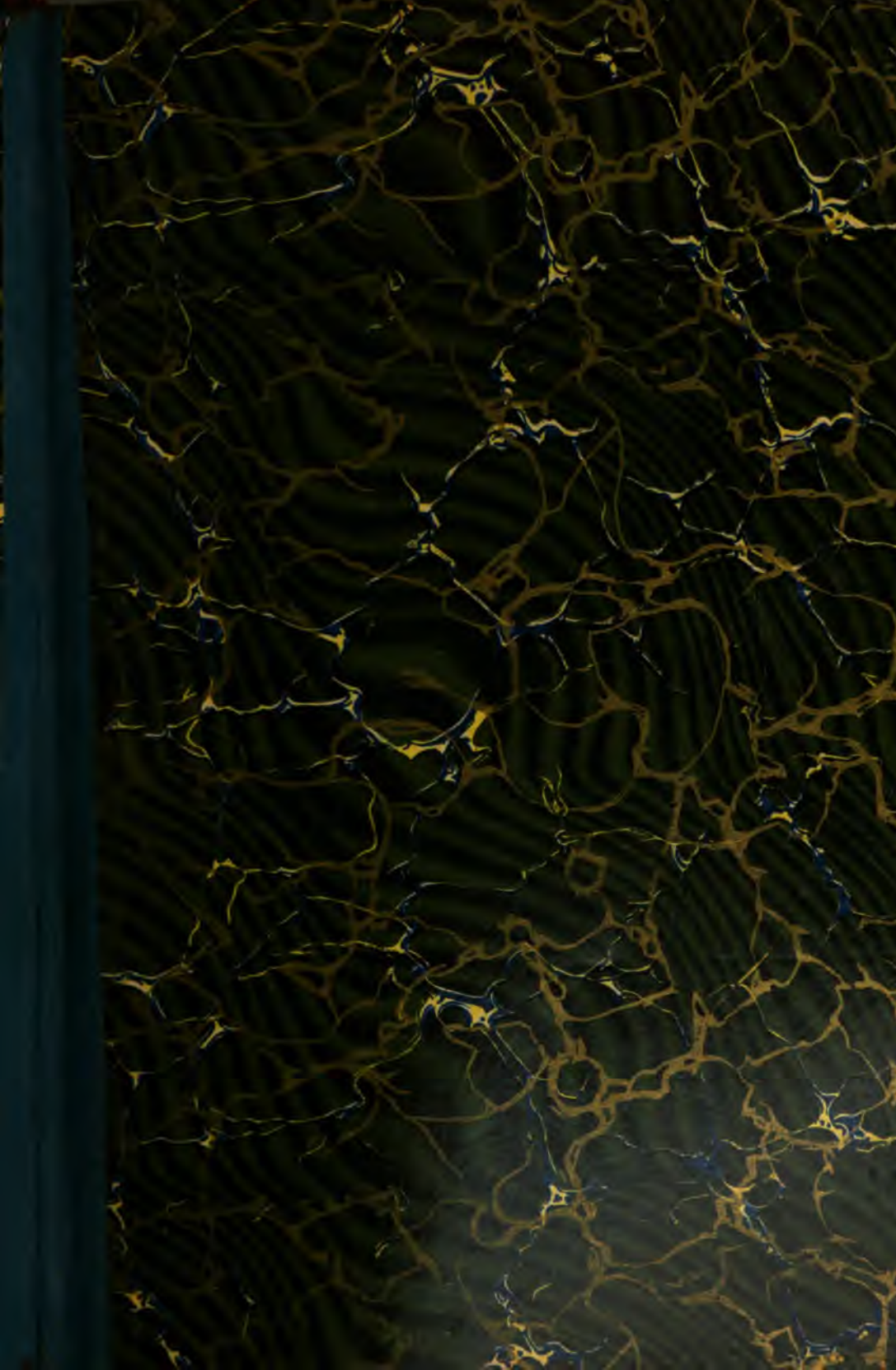

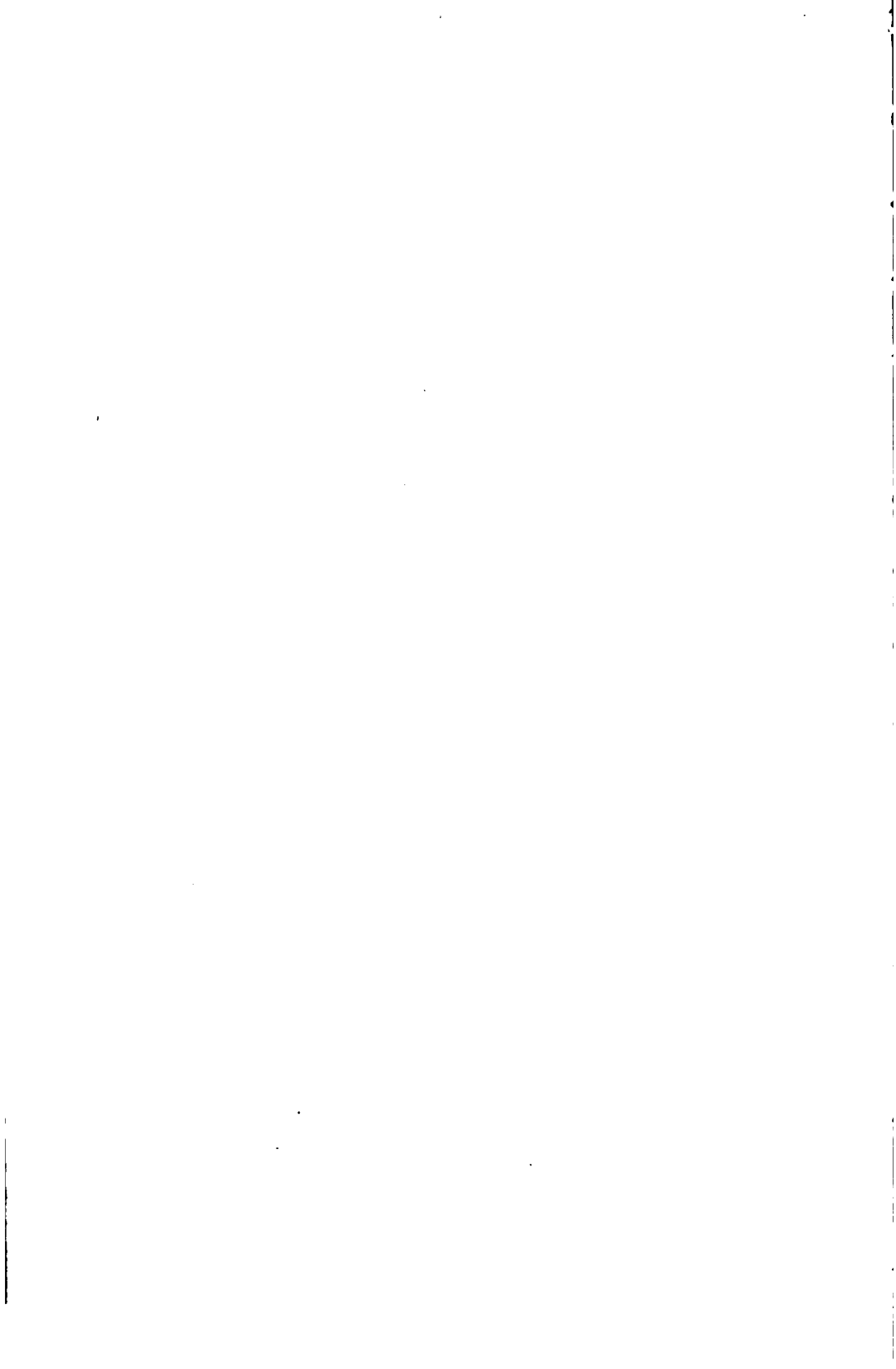

T  
7  
I61  
V.37

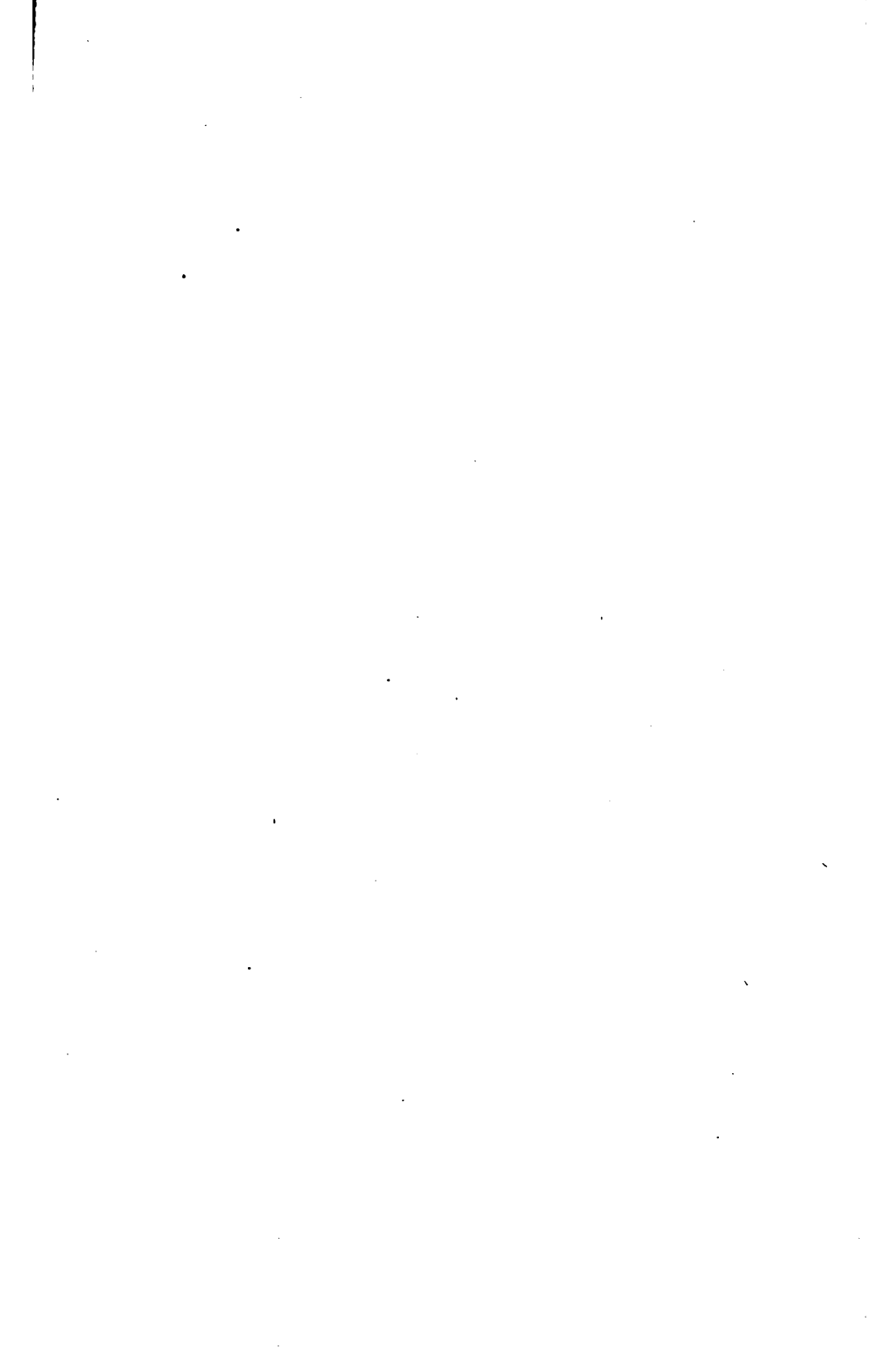

# INTERNATIONAL LIBRARY OF TECHNOLOGY

A SERIES OF TEXTBOOKS FOR PERSONS ENGAGED IN THE ENGINEERING  
PROFESSIONS AND TRADES OR FOR THOSE WHO DESIRE  
INFORMATION CONCERNING THEM. FULLY ILLUSTRATED  
AND CONTAINING NUMEROUS PRACTICAL  
EXAMPLES AND THEIR SOLUTIONS

GASES MET WITH IN MINES  
MINE VENTILATION  
ECONOMIC GEOLOGY OF COAL  
PROSPECTING FOR COAL AND LOCATION  
OF OPENINGS  
SHAFTS, SLOPES, AND DRIFTS  
METHODS OF WORKING COAL MINES  
ELECTRIC HOISTING AND HAULAGE  
ELECTRIC PUMPING, SIGNALING AND  
LIGHTING  
ELECTRIC COAL-CUTTING MACHINERY



SCRANTON:  
INTERNATIONAL TEXTBOOK COMPANY



Copyright, 1898, 1899, 1900, by THE COLLIERY ENGINEER COMPANY.  
Copyright, 1903, by INTERNATIONAL TEXTBOOK COMPANY.

---

Gases Met With in Mines: Copyright, 1894, 1897, 1900, by THE COLLIERY ENGINEER COMPANY.

Mine Ventilation: Copyright, 1895, 1897, by THE COLLIERY ENGINEER COMPANY.

Economic Geology of Coal: Copyright, 1893, 1895, by THE COLLIERY ENGINEER COMPANY.

Prospecting for Coal and Location of Openings: Copyright, 1893, 1895, by THE COLLIERY ENGINEER COMPANY.

Shafts, Slopes, and Drifts: Copyright, 1893, 1897, by THE COLLIERY ENGINEER COMPANY.

Methods of Working Coal Mines: Copyright, 1897, by THE COLLIERY ENGINEER COMPANY.

Electric Hoisting and Haulage: Copyright, 1900, by THE COLLIERY ENGINEER COMPANY.

Electric Pumping, Signaling, and Lighting: Copyright, 1900, by THE COLLIERY ENGINEER COMPANY.

Electric Coal-Cutting Machinery: Copyright, 1900, by THE COLLIERY ENGINEER COMPANY.

---

All rights reserved.

*187a*

BURR PRINTING HOUSE,  
FRANKFORT AND JACOB STREETS  
NEW YORK.

1  
2  
3  
4  
5  
6  
7  
8  
9  
10  
11  
12  
13  
14  
15  
16  
17  
18  
19  
20  
21  
22  
23  
24  
25  
26  
27  
28  
29  
30  
31  
32  
33  
34  
35  
36  
37  
38  
39  
40  
41  
42  
43  
44  
45  
46  
47  
48  
49  
50  
51  
52  
53  
54  
55  
56  
57  
58  
59  
60  
61  
62  
63  
64  
65  
66  
67  
68  
69  
70  
71  
72  
73  
74  
75  
76  
77  
78  
79  
80  
81  
82  
83  
84  
85  
86  
87  
88  
89  
90  
91  
92  
93  
94  
95  
96  
97  
98  
99  
100

## PREFACE

---

The International Library of Technology is the outgrowth of a large and increasing demand that has arisen for the Reference Libraries of the International Correspondence Schools on the part of those who are not students of the Schools. As the volumes composing this Library are all printed from the same plates used in printing the Reference Libraries above mentioned, a few words are necessary regarding the scope and purpose of the instruction imparted to the students of—and the class of students taught by—these Schools, in order to afford a clear understanding of their salient and unique features.

The only requirement for admission to any of the courses offered by the International Correspondence Schools is that the applicant shall be able to read the English language and to write it sufficiently well to make his written answers to the questions asked him intelligible. Each course is complete in itself, and no textbooks are required other than those prepared by the Schools for the particular course selected. The students themselves are from every class, trade, and profession and from every country; they are, almost without exception, busily engaged in some vocation, and can spare but little time for study, and that usually outside of their regular working hours. The information desired is such as can be immediately applied in practice, so that the student may be enabled to exchange his present vocation for a more congenial one or to rise to a higher level in the one he now pursues. Furthermore, he

wishes to obtain a good working knowledge of the subjects treated in the shortest time and in the most direct manner possible.

In meeting these requirements, we have produced a set of books that in many respects, and particularly in the general plan followed, are absolutely unique. In the majority of subjects treated the knowledge of mathematics required is limited to the simplest principles of arithmetic and mensuration, and in no case is any greater knowledge of mathematics needed than the simplest elementary principles of algebra, geometry, and trigonometry, with a thorough, practical acquaintance with the use of the logarithmic table. To effect this result, derivations of rules and formulas are omitted, but thorough and complete instructions are given regarding how, when, and under what circumstances any particular rule, formula, or process should be applied; and whenever possible one or more examples, such as would be likely to arise in actual practice—together with their solutions—are given to illustrate and explain its application.

In preparing these textbooks, it has been our constant endeavor to view the matter from the student's standpoint, and to try and anticipate everything that would cause him trouble. The utmost pains have been taken to avoid and correct any and all ambiguous expressions—both those due to faulty rhetoric and those due to insufficiency of statement or explanation. As the best way to make a statement, explanation, or description clear is to give a picture or a diagram in connection with it, illustrations have been used almost without limit. The illustrations have in all cases been adapted to the requirements of the text, and projections and sections or outline, partially shaded, or full-shaded perspectives have been used, according to which will best produce the desired results. Half-tones have been used rather sparingly, except in those cases where the general effect is desired rather than the actual details.

It is obvious that books prepared along the lines mentioned must not only be clear and concise beyond anything

heretofore attempted, but they must also possess unequaled value for reference purposes. They not only give the maximum of information in a minimum space, but this information is so ingeniously arranged and correlated, and the indexes are so full and complete, that it can at once be made available to the reader. The numerous examples and explanatory remarks, together with the absence of long demonstrations and abstruse mathematical calculations, are of great assistance in helping one to select the proper formula, method, or process and in teaching him how and when it should be used.

The present is the first of a series of three volumes devoted to mining engineering and treats on mine gases, mine ventilation, economic geology of coal, prospecting for coal, location of openings, shafts, slopes, drifts, methods of working coal mines, and electric mining machinery. Mine Ventilation, Part 1, treats on the theory of mine ventilation, and it is believed presents this somewhat difficult subject in clearer and simpler language than has heretofore been successfully attempted. The papers relating to electric mining explain the workings, advantages, and disadvantages of machinery operated by electricity that are used in mining operations; they treat on electrically driven hoisting, haulage, and coal-cutting machinery, electric pumps and pumping, and signaling and lighting by electricity.

The method of numbering the pages, cuts, articles, etc. is such that each subject or part, when the subject is divided into two or more parts, is complete in itself; hence, in order to make the index intelligible, it was necessary to give each subject or part a number. This number is placed at the top of each page, on the headline, opposite the page number; and to distinguish it from the page number it is preceded by the printer's section mark (§). Consequently, a reference such as § 37, page 26, will be readily found by looking along the inside edges of the headlines until § 37 is found, and then through § 37 until page 26 is found.

INTERNATIONAL TEXTBOOK COMPANY.

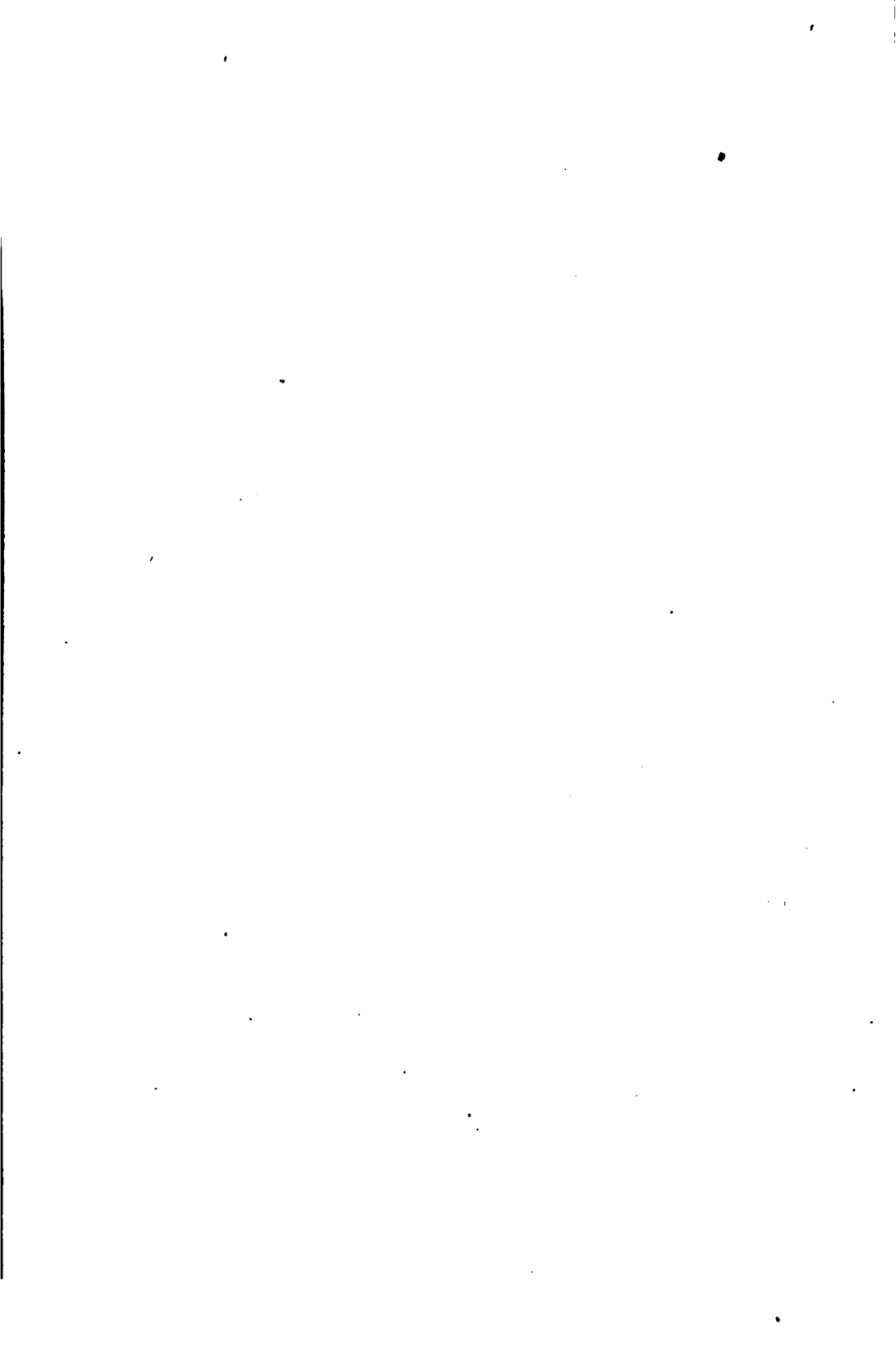

# CONTENTS

---

GASES MET WITH IN MINES	<i>Section</i>	<i>Page</i>
Chemistry . . . . .	5	1
Air and Gases . . . . .	5	15
Combustion . . . . .	5	45
Explosives and Explosions . . . . .	5	46
Safety Lamps . . . . .	5	62
Testing for Firedamp . . . . .	5	74
<b>MINE VENTILATION</b>		
Gravitation . . . . .	6	1
Falling Bodies . . . . .	6	4
Quantity of Air Required . . . . .	6	10
Flow of Air . . . . .	6	12
Friction . . . . .	6	16
Work and Power . . . . .	6	28
Laws of Ventilation . . . . .	6	42
Splitting the Air . . . . .	6	49
Regulators . . . . .	6	59
Production of Ventilating Currents . . . . .	7	1
Motive Column of Air . . . . .	7	7
Ventilating by Furnaces . . . . .	7	9
Mechanical Ventilators . . . . .	7	16
Centrifugal Force . . . . .	7	35
Fans . . . . .	7	44
Practical Ventilation . . . . .	7	48
Water Gauge and Anemometer . . . . .	7	52
Ventilating Gaseous and Non-Gaseous Seams . . . . .	7	62

	<i>Section</i>	<i>Page</i>
<b>ECONOMIC GEOLOGY OF COAL</b>		
Surface and Structural Geology . . . . .	11	1
The Earth's Crust . . . . .	11	2
Stratified Rocks . . . . .	11	3
Origin and Distribution of Fossils . . . . .	11	11
Unstratified, or Igneous, Rocks . . . . .	11	13
Metamorphic Rocks . . . . .	11	16
Structure Common to all Rocks . . . . .	11	18
Faults . . . . .	11	20
Historical Geology . . . . .	11	28
Coal Seams . . . . .	11	58
Varieties of Coal . . . . .	11	62
Varieties of Limestone . . . . .	11	65
Glossary . . . . .	11	67
<b>PROSPECTING FOR COAL AND LOCATION OF OPENINGS</b>		
Preliminary Examinations . . . . .	12	1
Coal-Measure Topography . . . . .	12	7
Determination of Quantity and Quality of Coal . . . . .	12	43
Location of Openings . . . . .	12	52
<b>SHAFTS, SLOPES, AND DRIFTS</b>		
Location of Shafts . . . . .	13	3
Forms of Shafts . . . . .	13	4
The Process of Sinking . . . . .	13	29
Special Sinking Devices . . . . .	13	42
Deepening Shafts . . . . .	13	62
Widening Shafts . . . . .	13	63
Conductors, Guides, or Slides . . . . .	13	64
Slope Sinking and Timbering . . . . .	13	68
Walling . . . . .	13	75
Sinking Operations . . . . .	13	78
Drifts . . . . .	13	79
<b>METHODS OF WORKING COAL MINES</b>		
Shaft Pillars . . . . .	14	1
Slope Pillars . . . . .	14	5

# CONTENTS

ix

## METHODS OF WORKING COAL MINES—*Continued*

	<i>Section</i>	<i>Page</i>
Slope Landings and Shaft Bottoms . . . . .	14	7
Pillars in the Main Workings . . . . .	14	13
Methods of Working Bituminous Seams . . . . .	14	19
Methods of Working Anthracite Seams . . . . .	14	25
Methods of Opening and Working		
Breasts, Chambers, or Rooms . . . . .	14	28
Rock-Chute and Tunnel Mining . . . . .	14	42
Working Contiguous Seams . . . . .	14	45
Barrier Pillars . . . . .	14	47
Approaching Abandoned Workings . . . . .	14	48
Propping . . . . .	14	49
Gangways, Levels, Headings, or Entries . . . . .	14	52
Underground Roads . . . . .	14	61
Dams . . . . .	14	76
Longwall Methods . . . . .	15	1
The Working Face . . . . .	15	3
Order of Working Contiguous Seams . . . . .	15	14
Systems of Longwall . . . . .	15	16
Creep in Longwall . . . . .	15	61
Testing the Roof . . . . .	15	62
Drawing Timber . . . . .	15	63

## ELECTRIC HOISTING AND HAULAGE

Power Transmission at Mines . . . . .	31	1
Electrical Transmission . . . . .	31	3
Electric Hoisting . . . . .	31	16
Electric Haulage . . . . .	31	25

## ELECTRIC PUMPING, SIGNALING, AND LIGHTING

Pumping . . . . .	32	1
Electric Signaling in Mines . . . . .	32	18
Electric Lighting in Mines . . . . .	32	39
Arc Lamps . . . . .	32	41
Lighting Systems . . . . .	32	43
Conductors . . . . .	32	46
Protection Against Short Circuits . . . . .	32	53



## ELECTRIC PUMPING, SIGNALING, AND LIGHTING—

<i>Continued</i>	<i>Section</i>	<i>Page</i>
Switches . . . . .	32	57
Series Arc-Light System . . . . .	32	61

## ELECTRIC COAL-CUTTING MACHINERY

Electric Coal-Cutting Machinery . . . . .	33	1
The Transmission of Electric Energy to Mining Machines . . . . .	33	2
Chain Coal-Cutting Machines . . . . .	33	5
Methods of Operating and Handling Chain Coal-Cutting Machines . . . . .	33	11
Chain Shearing Machines . . . . .	33	15
Cutter-Bar Machines . . . . .	33	26
Pick Machines . . . . .	33	27
General Remarks . . . . .	33	33

# GASES MET WITH IN MINES.

---

## CHEMISTRY.

---

### COMPOSITION OF MATTER.

**828. Chemistry** is that branch of science which treats of the composition of substances and the alterations they undergo in their composition by a change in the kind, number, and relative position of their atoms.

**829. Mass and Volume.**—The mass of a body is the amount of matter contained in it.

The volume of a body is the space which it occupies. If a body of irregular shape be plunged into a cylindrical jar of water, the rise of the water in the jar, multiplied by the area of its cross-section, will give the exact volume of the body. *Volume is always equal to displacement.*

**830. Density** is compactness of mass, and has reference to the amount of matter in a given volume of a body. Thus, there is more matter in a cubic foot of iron than in a cubic foot of water; therefore, we say iron is more dense than water; likewise, carbonic acid gas is more dense than air.

**831. Specific Gravity.**—The specific gravity of any body whatever—solid, liquid, or gas—is the measure of its density. And, in order to measure anything, we must have a standard, or unit, of measure. The standard, or unit, by which we measure the density of all solids and liquids alike is water. In like manner, the unit of measure for all mine gases is air. The chemist uses hydrogen gas as his unit of measure for gases.

Our units of measure, then, are as follows:

For solids and liquids, 62.5 lb. = weight 1 cu. ft. water.

For gases, .0766 lb. = weight 1 cu. ft. air (temperature, 60° F.; barometer, 30").

For example, if we wish to measure the density of iron, we must first know the weight of 1 cubic foot of the iron, and we then find how many times our unit of measure is contained in this weight, which will give us the density (specific gravity) of the iron. Thus, we know the weight of a certain kind of iron is 480 pounds per cubic foot, and we wish to determine its specific gravity. Applying our measure of the density of solids, we find that  $\frac{480}{62.5} = 7.68$  is the specific gravity of this iron.

The student must notice carefully that the specific gravity of a body is always the ratio between the weights of equal volumes of the body and of the unit or standard. For this reason, if we take any equal volume of the body and of the unit, or standard, and divide the weight of the one by the weight of the other, we will obtain the same ratio or specific gravity. Now, if we take any irregular piece of coal or other substance, and having first weighed it in the air, we then weigh this same piece of coal in water, the coal will be buoyed up by the weight of the water which it displaces. Hence, the amount the coal loses, when weighed in water, is the same as the weight of its own volume of water. Therefore, it is evident that if we divide the weight of any solid when weighed in air by the loss of weight when weighed in water, we shall obtain the same ratio, which is the specific gravity of the substance.

From the foregoing, we have the following rule to find the specific gravity of any solid:

**Rule.**—*Divide the weight of the substance in air by the difference between its weight in air and its weight in water; the quotient will be the specific gravity of the substance.*

Let  $W$  = weight of the substance in air;

$W_1$  = weight of the substance in water;

Sp. Gr. = specific gravity of the substance.

Then, 
$$\text{Sp. Gr.} = \frac{W}{W - W_1} \quad (1.)$$

**EXAMPLE.**—The weight of a piece of coal in the air is 7.62 lb.; when weighed in water, it weighs only 1.62 lb. What is its specific gravity?

**SOLUTION.**—
$$\frac{7.62}{(7.62 - 1.62)} = \frac{7.62}{6} = 1.27. \quad \text{Ans.}$$

Or, if we know the weight of 1 cubic foot of a substance—solid, liquid, or gas—and we divide its weight per cubic foot by our unit of measure, the result will be the same as the specific gravity. Thus, we have the following rule for finding the specific gravity of any solid, liquid, or gas when the weight per cubic foot is given.

**Rule.**—(a) *For Solids or Liquids.*—Divide the weight per cubic foot of the solid or liquid by the unit weight of the standard (weight of 1 cubic foot of water, 62.5 pounds); the quotient will be the specific gravity of the solid or liquid.

(b) *For Gases.*—Divide the weight per cubic foot of the gas by the unit weight of the standard for gases (weight of 1 cubic foot of air, temperature 60° F., barometer 30 inches); the quotient will be the specific gravity of the gas.

Let  $w$  = weight of 1 cubic foot of the solid, liquid, or gas.  
Then, we have

(a) For solids or liquids,

$$\text{Sp. Gr.} = \frac{w}{62.5}. \quad (2.)$$

(b) For gases,

$$\text{Sp. Gr.} = \frac{w}{.0766}. \quad (3.)$$

**EXAMPLE.**—Take the weight of a cubic foot of mercury as 850 pounds (at normal temperature and pressure), and find its specific gravity.

**SOLUTION.**—
$$\frac{850}{62.5} = 13.6. \quad \text{Ans.}$$

**EXAMPLE.**—If the weight of a cubic foot of carbonic acid gas at a temperature of 60° F. and a pressure of 30' of mercury is .117129 pound, what is its specific gravity?

**SOLUTION.**—
$$\frac{.117129}{.0766} = 1.5291. \quad \text{Ans.}$$

**832.** To make plain the true relation of the terms mass, volume, density, and specific gravity, let us suppose we have 1,000 cubic feet of air at the ordinary atmospheric pressure. If this pressure is increased to two atmospheres, the volume will be reduced to one-half of what it was. The mass, however, will not be changed, because the quantity of matter is still the same; but the density of the air is doubled, and the specific gravity is doubled, since each cubic foot of air contains twice the mass that it contained before compression, while the reduced volume of 500 cubic feet of air contains the same mass that was contained in the 1,000 cubic feet.

The practical use to which the specific gravity of a body is applied is to calculate the weight of a given volume of the substance. For example, the weight of a cubic foot of water is 62.5 pounds, and if the specific gravity of a sample of bituminous coal is 1.27, then the weight of a cubic foot of bituminous coal will be  $62.5 \times 1.27 = 79.375$  pounds.

**Rule.**—(a) *For Solids or Liquids.*—Multiply the weight of one cubic foot of water (62.5) by the specific gravity of the solid or liquid; the product will be the weight of one cubic foot of the solid or liquid.

(b) *For Gases.*—Multiply the weight of one cubic foot of air (.0766 pound), temperature 60° F., barometer 30", by the specific gravity of the gas; the product will be the weight of one cubic foot of the gas.

(a) For solids or liquids,

$$w = 62.5 \times \text{Sp. Gr.} \quad (4.)$$

(b) For gases,

$$w = .0766 \times \text{Sp. Gr.} \quad (5.)$$

#### EXAMPLES FOR PRACTICE.

1. What is the weight of a cubic foot of anthracite coal having a specific gravity of 1.55? Ans. 96.875 pounds.
2. Find the weight of 100 cubic yards of earth having a specific gravity of 1.75. Ans. 147.656 tons.
3. What is the weight of 200 cubic feet of carbonic acid gas at a

temperature of 60° F. and a barometer pressure of 30 inches, the specific gravity of the gas being 1.5291 (see formula 5)?

Ans. 23.4258 pounds.

4. Find the weight of 500 cubic feet of marsh-gas at a temperature of 60° F. and a pressure due to 30 inches of barometer, the gas having a specific gravity of 0.559.

Ans. 21.41 pounds, nearly.

**833. Matter.**—Matter is the substance of which the universe consists. It is indestructible and subject to changes of form under different conditions of heat and pressure; therefore, we find it assuming all the three forms common to matter; namely, the gaseous, liquid, and solid. In all the conditions in which we find matter, it consists of atoms and molecules.

**834. Atoms and Molecules.**—*Atoms.*—An atom is the smallest conceivable division of matter; and, hence, an atom is always simple in its character.

*Molecules.*—A molecule is formed by the chemical union of two or more atoms. The atoms composing a molecule may be *like* or *unlike*; and, hence, the molecule may be either simple or compound.

The force that binds *atoms* together to form a molecule is a chemical force, which we call *affinity*.

The force that binds *molecules* together to form *mass* is a molecular force, which we call *attraction*.

*Affinity* binds *atoms* together.

*Attraction* unites *molecules*.

**835. Elements.**—An elementary body consists of a simple substance that can not be analyzed or reduced to parts that have other properties than those peculiar to itself. An element is a substance, or form of matter, composed wholly of *like* atoms. Thus, *hydrogen* is an element, because it is composed only of hydrogen atoms. For the same reason, oxygen, nitrogen, carbon, iron, lead, silver, gold, etc., are all elements. Table 17 comprises the most of the elements now known.

**836. Compounds.**—Any substance or form of matter that is composed of *unlike* atoms is a compound. Two classes of compounds exist, viz.:

(a) **Chemical compounds**, in which the combining atoms unite in definite, fixed proportions, according to chemical laws, which give to the atoms of each element certain combining powers. For example, water is a chemical compound, being always formed by the union of *two* atoms of hydrogen to *one* atom of oxygen.

In like manner, when *one* atom of carbon unites with *one* atom of oxygen, carbonic oxide gas is formed; but when *one* atom of carbon unites with *two* atoms of oxygen, carbonic acid gas is produced. These two gases have very different properties.

Again, when *one* atom of carbon unites with *four* atoms of hydrogen, marsh-gas results; but when *two* atoms of carbon unite with the *four* atoms of hydrogen, olefiant gas (ethene) is produced.

These are all examples of chemical compounds, as are also salt, blue vitriol, nitric acid, etc., for they are all formed by the chemical union of dissimilar atoms.

(b) **Mechanical mixtures** are not *true compounds*, as they are composed more properly of *unlike molecules*, in place of *unlike atoms*. The molecules of the different substances forming the mixture may be present in any proportions, and the mixture will have properties varying with the proportions of the ingredients.

The atmosphere about us is a good example of a mechanical mixture, as we shall see later, for it consists principally of oxygen and nitrogen gases, mixed in a free state (having no chemical bond of union). The proportion of these two gases in the atmosphere is quite constant, being approximately *one* of oxygen to *four* of nitrogen.

Solutions of different salts in water are examples of mechanical mixtures; the strength of the solution or mixture will vary with the amount of salt dissolved.

TABLE 17.

Name.	Symbol.	Atomic Weight.	Name.	Symbol.	Atomic Weight.
* <b>Aluminium,</b>	<i>Al.</i>	27.4	<b>Mercury,</b>	<i>Hg.</i>	200.0
* <b>Antimony,</b>	<i>Sb.</i>	122.0	* <b>Molybdenum,</b>	<i>Mo.</i>	96.0
* <b>Arsenic,</b>	<i>As.</i>	75.0	Nickel,	<i>Ni.</i>	58.0
Barium,	<i>Ba.</i>	187.0	Niobium (Col-		
Beryllium (Glu-			umbium, Cb.),	<i>Nb.</i>	94.0
cinum, Gl.),	<i>Be.</i>	9.2	<b>Nitrogen,</b>	<i>N.</i>	14.0
Bismuth,	<i>Bi.</i>	210.0	Osmium,	<i>Os.</i>	200.0
Boron,	<i>B.</i>	11.0	<b>Oxygen,</b>	<i>O.</i>	16.0
<i>Bromine,</i>	<i>Br.</i>	80.0	Palladium,	<i>Pd.</i>	106.0
Cadmium,	<i>Cd.</i>	112.0	* <b>Phosphorus,</b>	<i>P.</i>	31.0
Cæsium,	<i>Cs.</i>	188.0	Platinum,	<i>Pt.</i>	197.4
<b>Calcium,</b>	<i>Ca.</i>	40.0	<b>Potassium,</b>	<i>K.</i>	39.1
* <b>Carbon,</b>	<i>C.</i>	12.0	Rhodium,	<i>Rh.</i>	104.0
Cerium,	<i>Ce.</i>	91.8	Rubidium,	<i>Rb.</i>	85.4
<b>Chlorine,</b>	<i>Cl.</i>	35.5	Ruthenium,	<i>Ru.</i>	104.0
* <b>Chromium,</b>	<i>Cr.</i>	52.2	Samarium,	<i>Sm.</i>	150.0
Cobalt,	<i>Co.</i>	60.0	Scandium,	<i>Sc.</i>	44.9
* <b>Columbium (Ni-</b>			* <b>Selenium,</b>	<i>Se.</i>	79.0
obium, Nb.),	<i>Cb.</i>	94.0	* <b>Silicon,</b>	<i>Si.</i>	28.0
<b>Copper,</b>	<i>Cu.</i>	63.4	<b>Silver,</b>	<i>Ag.</i>	108.0
Decipium,	<i>Dp.</i>	159.0	<b>Sodium,</b>	<i>Na.</i>	23.0
Didymium,	<i>D.</i>	95.0	Strontium,	<i>Sr.</i>	88.0
Erbium,	<i>E.</i>	112.6	* <b>Sulphur,</b>	<i>S.</i>	32.0
<i>Fluorine,</i>	<i>F.</i>	19.0	* <b>Tantalum,</b>	<i>Ta.</i>	182.0
Gallium,	<i>Ga.</i>	69.8	* <b>Tellurium,</b>	<i>Te.</i>	128.0
Glucinum (Beryl-			Terbium,	<i>Tb.</i>	75.4
lium, Be.),	<i>Gl.</i>	9.2	Thallium,	<i>Tl.</i>	204.0
* <b>Gold,</b>	<i>Au.</i>	197.0	Thorium,	<i>Th.</i>	118.4
* <b>Hydrogen,</b>	<i>H.</i>	1.0	* <b>Tin,</b>	<i>Sn.</i>	118.0
Indium,	<i>In.</i>	113.4	* <b>Titanium,</b>	<i>Ti.</i>	50.0
<i>Iodine,</i>	<i>I.</i>	127.0	* <b>Tungsten,</b>	<i>W.</i>	184.0
Iridium,	<i>Ir.</i>	198.0	* <b>Uranium,</b>	<i>U.</i>	120.0
<b>Iron,</b>	<i>Fe.</i>	56.0	Vanadium,	<i>V.</i>	51.8
Lanthanum,	<i>La.</i>	92.0	Ytterbium,	<i>Yb.</i>	173.0
<b>Lead,</b>	<i>Pb.</i>	207.0	Yttrium,	<i>Y.</i>	89.0
Lithium,	<i>Li.</i>	7.0	Zinc,	<i>Zn.</i>	65.0
Magnesium,	<i>Mg.</i>	24.0	Zirconium,	<i>Zr.</i>	89.6
* <b>Manganese,</b>	<i>Mn.</i>	55.0			

\* Sometimes basic, sometimes acid.

NOTE.—Heavy-faced type indicates the elements of most importance to the student of this subject. Basic elements are printed in common type; acid elements in italics.



**837. Dissociation.**—This part of our subject would not be complete without some particular reference to the mode of union and disunion of atoms. The affinities which exist between the atoms of the different elements vary very much. In some cases, the affinity is so slight as to render the compound very unstable, and dissociation of the atoms will ensue from the least cause. Examples of this are the various fulminators and some of the detonating explosives. On the other hand, the affinities between atoms of certain other elements, as oxygen and hydrogen, or oxygen and carbon, are very strong, and their union is very apt to be accompanied with the manifestation of considerable energy, either in the form of heat or mechanical work.

In this development of energy, incident to the dissociation of atoms, lies one of the most important principles in the chemistry of mining.

**838. Atomic Weights.**—By this we mean the weights of the atoms of all the elementary bodies. These weights are expressed in terms of the weight of the hydrogen atom; that is, the lightest known element in nature; for example, it is said the atomic weight of nitrogen is 14, meaning to say that an atom of nitrogen is 14 times as heavy as an atom of hydrogen, and so on with the atomic weights of the other elements.

Table 17 gives the most of the known elements, with their respective symbols and atomic weights.

*Atomic weight* means only *relative weight*. It does not mean pounds, or ounces, or grammes, or any other denomination in particular. For example, since, from analysis, we know that water is a chemical compound formed by the union of *two* atoms of hydrogen with *one* atom of oxygen, the **molecular weight** (weight of 1 molecule) of water ( $H_2O$ ) will be as follows:

Hydrogen ( $H_2$ ), 2 atoms	$(2 \times 1) =$	2
Oxygen ( $O$ ), 1 atom	$=$	16
Water ( $H_2O$ ), 1 molecule	$=$	<u>18</u> = molecular weight.

Then, we readily see that hydrogen forms  $\frac{2}{18} = \frac{1}{9}$  of the

weight of water, and oxygen forms  $\frac{1}{8}$  =  $\frac{1}{8}$  of the weight of the same.

In the same way, the atomic weight of carbon being 12 and that of hydrogen 1, we have for the weight of a molecule (called *molecular weight*) of marsh-gas ( $CH_4$ ):

Carbon ( $C$ ), 1 atom = 12

Hydrogen ( $H_4$ ), 4 atoms ( $4 \times 1$ ) = 4

Marsh-gas ( $CH_4$ ), 1 molecule = 16 = molecular weight.

We see, therefore, that the carbon forms  $\frac{1}{8}$  =  $\frac{1}{8}$ , or 75 per cent. by weight of the marsh-gas, and hydrogen forms  $\frac{4}{16}$  =  $\frac{1}{4}$ , or 25 per cent. of the same.

This makes plain that the atomic weights of the various elements are only relative, hydrogen being taken as unity.

**EXAMPLES.**—(a) What per cent. of the weight of carbonic oxide gas is pure oxygen?

**SOLUTION.**—Carbonic oxide gas ( $CO$ ) contains one atom of carbon and one atom of oxygen, by weight, carbon 12 parts and oxygen 16 parts (see Table 17), 12 and 16 being the relative weights of the atoms, or the atomic weights, of carbon and oxygen. The molecular weight, therefore, of carbonic oxide gas is  $12 + 16 = 28$ , of which oxygen forms  $\frac{16}{28}$  =  $\frac{4}{7}$  = 57.143 per cent., nearly. Ans.

(b) What weight of carbonic acid gas will be produced in burning 100 pounds of coal containing 90 per cent. of carbon?

**SOLUTION.**— 90% of 100 = 90 pounds of carbon.

Carbon ( $C$ ) atomic weight (Table 17) 1 atom 12

Oxygen ( $O_2$ ) atomic weight (Table 17) 2 atoms ( $16 \times 2$ ) 32

Carbonic acid gas ( $CO_2$ ), molecular weight 44

Percentage of carbon =  $\frac{12}{44}$  =  $\frac{3}{11}$  = 27.27%. Then, 90 pounds of carbon is  $\frac{3}{11}$  of the weight of carbonic acid gas formed, and  $\frac{3}{11}$  =  $\frac{1}{4}$  of 90 = 30 pounds, and  $\frac{11}{4}$  or the whole weight of gas formed =  $30 \times 11 = 330$  pounds. Ans.

(c) If the specific gravity of carbonic acid gas is 1.5291, what volume of gas, at a temperature of 60° F., and a barometric pressure equal to 30", will be produced, in the last problem, by burning the 100 pounds of coal, which we found yields 330 pounds of this gas?

**SOLUTION.**—The specific gravity of the gas being 1.5291, one cubic foot at the temperature and pressure given will weigh  $.0766 \times 1.5291 = .117129$  pounds; and 330 pounds of the gas will contain as many cubic

feet as  $\frac{330}{.117129} = 2,817.4$  cubic feet. Ans.

## EXAMPLES FOR PRACTICE.

1. What percentage of the weight of marsh-gas ( $CH_4$ ) is pure hydrogen (a molecule of marsh-gas containing *one* atom of carbon and *four* atoms of hydrogen)?      Ans. 25%.

2. If the specific gravity of marsh-gas (Table 19) is 0.559, what weight of hydrogen will be contained in 1,000 cubic feet of this gas, at a temperature of  $60^\circ$  F., barometer 30' ?      Ans. 10.705 lb., nearly.

3. If all of the hydrogen in example 2 were to unite with oxygen (in the proportion of *two* atoms of hydrogen to *one* atom of oxygen) to form water, what weight of water would be produced ?

Ans. 96.345 lb.

4. What weight of carbon is contained in 100 cubic feet of carbonic oxide gas ( $CO$ ), a molecule of this gas containing *one* atom of carbon and *one* atom of oxygen, temperature =  $60^\circ$  F., barometer 30' ?

Ans. 3.1745 lb.

**839. Symbols.**—To facilitate the writing of chemical equations, each of the elements is expressed in writing by a symbol, as given in Table 17. In like manner, a chemical compound is expressed by the symbols of its constituent elements. Thus, water, composed of *two* atoms of hydrogen and *one* atom of oxygen, is expressed by the symbol  $H_2O$ . In the same manner, we write  $CO$  for carbonic oxide gas,  $CO_2$  for carbonic acid gas, and  $CH_4$  for carbureted hydrogen or marsh-gas; the number of atoms of each element, when more than one, being denoted by the little subscript figure following its symbol. When it is desired to express more than one *molecule*, we write the figure indicating the number before the formula of the molecule. Thus, four molecules of carbonic acid gas are written  $4CO_2$ , and in these four molecules there are *four* atoms of carbon and *eight* atoms of oxygen.

These symbols are, in most cases, the first letter of the name of the element itself. For example, the symbol for oxygen is  $O$ , for hydrogen it is  $H$ ; and such symbols are always capital letters. When the initial letters of the names of different elements are the same, one of the elements is designated by its initial letter; but each of the others has some additional letter to distinguish it, and this extra letter, in each case, is a small letter. Thus, the symbol for carbon

is *C*; for chlorine, *Cl*; for chromium, *Cr*; for cadmium, *Cd*, etc. Others of the elements have for their symbols an abbreviation of their Latin names; as, for example, the symbol for iron is *Fe* (Latin, *ferrum*), and silver, *Ag* (Latin, *argentum*). In writing chemical symbols, be careful that you do not use capitals and small letters indiscriminately, for the meaning may thereby be greatly changed. Thus, were we to write *CO* (carbonic oxide), a deadly gas would be meant, while if it had been made *Co*, it would represent the chemical symbol for cobalt.

**840. Chemical Equations.**—An equation expresses equality. We may have a numerical equation; as, for example,

$$2 + 4 = 3 \times 2.$$

The sign of equality divides the two equal members of an equation, always showing that they are equal to each other.

A *chemical equation* is used to show the arrangement and grouping of atoms, *before* and *after* a reaction. We must remember that *matter may be changed in its form, but can not be destroyed*; hence, the grouping of the atoms will be different after the reaction from what it was before the reaction took place; but the number and kind of atoms will be equal before and after such reaction. For example, when sulphuric acid ( $H_2SO_4$ ) acts upon metallic zinc (*Zn*), the hydrogen of the acid is replaced by the zinc, and the result is that a salt (sulphate of zinc) is formed and a gas (hydrogen) is set free. This reaction is expressed by the following chemical equation:

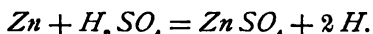

**841. Atomic volume** is relative volume, as atomic weight is relative weight. It has been ascertained that, with few exceptions, the specific gravities of simple gases, when referred to hydrogen as unity, are equal to their respective atomic weights; as, for example, the density (specific gravity) of nitrogen, referred to hydrogen, is 14; and, referring to Table 17, we see that its atomic weight is,

likewise, 14. From the foregoing has been deduced the following law:

**First Law of Volume.**—(a) *Like volumes of simple gases contain the same number of atoms.*

(b) *The atoms of all simple gases are of the same size.*

It has been further ascertained that the densities of compound gases are, with few exceptions, equal to one-half of their *molecular* weights; as, for example, the density of carbonic acid gas ( $CO_2$ ), referred to hydrogen as unity, is 22; its molecular weight (sum of the atomic weights of its elements) is  $12 + (2 \times 16) = 44$ . (See Table 17.) Hence, we see that its density is one-half of its molecular weight. From this the following law has been deduced:

**Second Law of Volume.**—*The molecules of compound gases occupy twice the volume of an atom of hydrogen gas.*

The exceptions to these general laws of volume are very few, and not important to our subject. The foregoing rules do not refer to solids or liquids.

These two *laws of volume* make it possible to determine the volume of gases resulting from any given chemical reaction. For example, when carbonic oxide gas burns, it unites with the oxygen of the air according to the equation

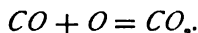

But the molecule  $CO$  (1 atom  $C$  and 1 atom  $O$ ) is, according to the second law of volume, equal to the size of *two* atoms of hydrogen gas; and, according to the first law of volume, the atom  $O$ , with which it unites, is equal in size to *one* atom of hydrogen gas. Hence, the volumes of  $CO$  and  $O$ , which unite, are to each other as 2 : 1. In the same manner, we find the volume of  $CO_2$  formed is equal to the original volume of  $CO$ . In other words, *two* volumes of carbonic oxide gas, mixed with *one* volume of oxygen, and exploded, will form only *two* volumes of carbonic acid gas.

In like manner, when ammonia ( $NH_3$ ) is decomposed in a tube, by electric sparks, it is found that *two* volumes  $NH_3$  yield *one* volume  $N$  and *three* volumes  $H$ , or *four* volumes of the simple gases.

**EXAMPLE.**—Determine the volume of carbonic acid gas ( $CO_2$ ) resulting from the explosion of 500 cubic feet of marsh-gas ( $CH_4$ ), at equal temperatures and pressures.

**SOLUTION.**—Assuming that all of the carbon ( $C$ ) of the marsh-gas is converted into carbonic acid gas ( $CO_2$ ), we find

1 molecule  $CH_4$  yields 1 molecule  $CO_2$ .

By the second law of volume, each of these molecules occupies twice the volume of an atom of hydrogen gas, and they are, therefore, equal to each other. Hence, 500 cubic feet of marsh-gas yield 500 cubic feet of carbonic acid gas, under the assumed conditions (equal temperatures and pressures). Ans.

**EXAMPLE.**—How many cubic feet of oxygen have been consumed in the formation of the 500 cubic feet of carbonic acid gas of the previous example?

**SOLUTION.**—*Two atoms* of oxygen are consumed in the formation of each *molecule* of carbonic acid gas ( $CO_2$ ). These *two* atoms, according to the first law of volume, are of the same size or volume as *two* atoms of *hydrogen* gas; likewise, according to the second law of volume, the *molecule* of carbonic acid gas formed occupies *twice* the volume of an atom of *hydrogen* gas. Hence, the volume of the oxygen consumed is equal to the volume of the gas formed (500 cu. ft.). Ans.

#### EXAMPLES FOR PRACTICE.

In the following examples, assume constant temperature and pressure:

1. How many cubic feet of oxygen will be consumed in the formation of 100 cubic feet of carbonic oxide gas ( $CO$ )?      Ans. 50 cu. ft.
2. If the hydrogen in 100 cubic feet of ammonia gas were set free, what volume would it make?      Ans. 150 cu. ft.
3. The formula for ethene, or olefiant gas, is  $C_2H_4$ ; what volume of oxygen will be required to convert 100 cubic feet of this gas into  $CO_2$  and  $H_2O$ ?      Ans. 800 cu. ft.

**842. Constitution of Matter.**—In order to rightly understand the relation of force to matter, we must consider the latter as made up of minute particles, which we have already termed atoms and molecules.

*The union of atoms produces molecules, and the union of molecules produces mass.*

The *atoms* forming the molecules of a substance may be *like* or *unlike*. When they are *like*, the substance is *elementary*; when *unlike*, it is *compound*.

The *molecules* of any homogeneous mass are always alike.

**843. Molecular Forces.**—The force which unites atoms is *affinity*; it is a chemical force.

The *molecules* of all matter are acted upon by two opposite or contrary forces; viz., the force of *attraction* and the force of *repulsion*. The former of these two forces acts to bind the molecules together, the latter to drive them apart. The *attractive* principle or force exists in every molecule of a mass, to draw it towards every other molecule; it is an inherent force, peculiar to all matter to a greater or less extent.

The *repulsive* force existing between the molecules of a mass is what may be termed an *imposed* force. It is not common to the mass, but is an induced or applied force. This repulsive force is largely the result of heat or the temperature of the mass.

**844. Heat Unit.**—We measure the quantity of heat by what is termed the *thermal*, or *heat*, *unit*. The British thermal unit is the amount of heat which will raise the temperature of one pound of water one degree of the Fahrenheit scale. Table 18 gives, in round numbers, the number of British thermal units produced by the burning of one pound of different solids and gases in oxygen.

**TABLE 18.**

Substance.	British Thermal Units (per Pound).
Hydrogen gas ( <i>H</i> ).....	62,000
Marsh-gas ( <i>CH</i> <sub>4</sub> ).....	23,500
Carbonic oxide gas ( <i>CO</i> )....	4,300
Anthracite coal.....	15,230
Bituminous coal.....	14,400
Coke.....	12,600
Wood (ordinary).....	5,000

## AIR AND GASES.

---

### THE ATMOSPHERE.

**845. Composition.**—An analysis of the atmosphere about us shows it to consist of a *mixture* of oxygen and nitrogen, with varying amounts of carbonic acid gas and ammonia. The oxygen and nitrogen are always free or uncombined, and are present in the proportions given below.

	By Volume.	By Weight.
Nitrogen,	79.3	77
Oxygen,	20.7	23
	<hr style="width: 50%; margin: 0 auto;"/> 100.0	<hr style="width: 50%; margin: 0 auto;"/> 100

The amounts of the other ingredients are changing all the time, due to local causes. Thus, the air of a crowded room, or a mine, or the air in the vicinity of large factories, may show a high percentage of carbonic acid gas; while, again, the air of an open field, just after a shower, may show scarcely a trace of this gas; while the proportions of oxygen and nitrogen will show no practical variation. The proportions of these two elements existing in the atmosphere, by volume, is in the ratio of about four volumes of nitrogen to one volume of oxygen. The oxygen and nitrogen are in a *free* state; that is, they are mechanically *mixed* in this proportion throughout the entire atmosphere, and are not chemically *combined*.

The atmosphere is essential to all animal and vegetable life. Its oxygen, which forms about one-fifth of its volume, enters into a large number of chemical reactions, and supports combustion in every form.

---

### PHYSICAL PROPERTIES OF AIR AND GASES.

**846. Weight of Air.**—It was supposed by the ancients that air had no weight, and it was not until about the year 1650 that it was proven that air really has weight. A cubic inch of air, under ordinary conditions, weighs .31 grain, nearly. The ratio of the weight of air to water is about



1 : 774; that is, air is only  $\frac{1}{774}$  as heavy as water. If a vessel, made of light material, be filled with a gas lighter than air, so that the total weight of the vessel and gas is less than the air which they displace, the vessel will rise. It is on this principle that balloons are made.

Since air has weight, it is evident that the enormous quantity of air that constitutes the atmosphere must exert

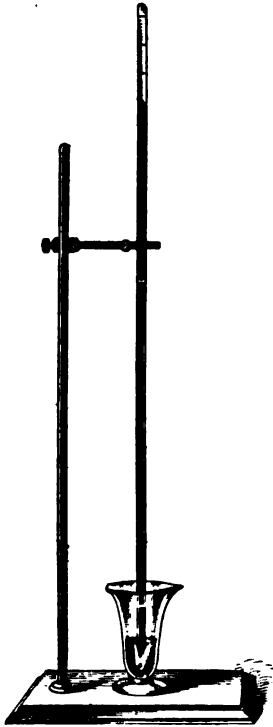

FIG. 110.

a considerable pressure upon the earth. This is easily proven by taking a long glass tube closed at one end and filling it with mercury. If the finger be placed over the open end so as to keep the mercury from running out, and the tube be inverted and placed in a glass of mercury, as shown in Fig. 110, the mercury in the tube will fall, then rise, and, after a few oscillations, will come to rest at a height above the top of the mercury in the glass equal to about 30 inches. This height will always be the same under the same atmospheric conditions. Now, if the atmosphere has weight, it must press upon the upper surface of the mercury in the glass with equal intensity upon every square unit, except upon that part of the surface occupied by the tube. In order that there will be equilibrium, the weight of the mer-

cury in the tube must be equal to the pressure of the air upon an area of the upper surface of the mercury in the glass, equal to the area of the inside of the tube. Suppose that the area of the inside of the tube is 1 square inch, then, since mercury is 13.6 times as heavy as water, and a cubic inch of water weighs .03617 pound, the weight of the mercurial column is  $.03617 \times 13.6 \times 30 = 14.7574$  pounds.

The actual height of the mercury is a little less than 30 inches, and the actual weight of a cubic inch of distilled water is a little less than .03617 pound. When these considerations are taken into account, the average weight of the mercurial column at the level of the sea under normal conditions is 14.69 pounds, or, practically, 14.7 pounds. Since this weight, exerted upon 1 square inch of the liquid in the glass, just produced equilibrium, it is plain that the pressure of the outside air is 14.7 pounds upon every square inch of surface.

**847. Vacuum.**—The space between the upper end of the tube and the upper surface of the mercury is called a *Toricellian vacuum*, or simply a *vacuum*, meaning that it is an entirely empty space, and does not contain any substance, solid, liquid, or gaseous. If there was a gas of some kind there, no matter how small the quantity might be, it would expand, filling the space, and its tension would cause the column of mercury to fall and become shorter, according to the amount of gas or air present. The space is then called a *partial vacuum*. If the mercury fell 1 inch, so that the column was only 29 inches high, we would say, in ordinary language, that there were 29 inches of vacuum. If it fell 8 inches, we would say that there were 22 inches of vacuum; if it fell 16 inches, we would say that there were 14 inches of vacuum, etc. Hence, when the vacuum-gauge of a condensing-engine shows 26 inches of vacuum, there is enough air in the condenser to produce a pressure of  $\frac{30 - 26}{30} \times 14.7 = \frac{4}{30} \times 14.7 = 1.96$  pounds per square inch.

If the tube had been filled with water instead of mercury, the height of the column of water to balance the pressure of the atmosphere would have been  $30 \times 13.6 = 408$  inches = 34 feet. This means that if a tube be filled with water, inverted, and placed in a dish of water in a manner similar to the experiment made with the mercury, the height of the column of water would be 34 feet.

**848.** The **barometer** is an instrument used for measuring the pressure of the atmosphere. There are two kinds in general use—the mercurial barometer and the aneroid barometer. The *mercurial barometer* is shown in Fig. 111.

The principle is the same as the inverted tube, shown in Fig. 110. In this case, the tube and cup at the bottom are protected by a brass or iron casing. Near the top of the tube is a graduated scale which can be read to  $\frac{1}{1000}$  of an inch by means of a vernier. Attached to the casing is an accurate thermometer for determining the temperature of the outside air at the time the barometric observation is taken. This is necessary, since mercury expands when the temperature is increased, and contracts when the temperature falls; for this reason a standard temperature is assumed, and all barometer readings are reduced to this temperature. This standard temperature is usually taken at 32° F., at which temperature the average height of the mercurial column at sea-level is 30 inches. Another correction is made for the altitude of the place above sea-level, and a third correction for the effects of capillary attraction.



FIG. 111.

In Fig. 112 is shown a cut of an *aneroid barometer*. These instruments are made in various sizes, from the size of a watch up to an 8 or 10 inch face. They consist of a cylindrical box of metal with a top of thin, elastic, corrugated metal. The air is removed from the box. When the atmospheric pressure increases, the top is pressed inwards, and when it is diminished, the top is pressed outwards by its own elasticity, aided by a spring beneath. These movements of the cover are transmitted and multiplied by a combination of delicate levers, which act upon an index-hand, and cause it to move either to the right or left, over a graduated scale. These barometers are self-correcting (compensated) for variations in temperature. They are

very portable, occupying but a small space, and are so delicate that they are said to show a difference in the atmospheric pressure when transferred from the table to the floor. The mercurial barometer is the standard. With air, as with water, the lower we get, the greater the pressure, and the higher we get, the less the pressure. At the level of the sea, the height of the mercurial column is about 30 inches; at 5,000 feet above the sea, it is 24.7 inches; at



FIG. 112.

10,000 feet above the sea, it is 20.5 inches; at 15,000 feet, it is 16.9 inches; at 3 miles, it is 16.4 inches, and at 6 miles above the sea-level, it is 8.9 inches.

**849. Density of Air.**—The density and weight of a cubic foot of air vary with the altitude; that is, a cubic foot of air at an elevation of 5,000 feet above the

sea-level will not weigh as much as a cubic foot at sea-level. This is proven conclusively by the fact that at a height of  $3\frac{1}{2}$  miles the mercurial column measures but 15 inches, indicating that half the weight of the entire atmosphere is below that. It is known that the height of the earth's atmosphere is at least 50 miles; hence, the air just before reaching the limit must be in an exceedingly rarefied state. It is by means of barometers that great heights are measured. The aneroid barometer has the heights marked on the dial, so that they can be read directly. With the mercurial barometer, the heights must be calculated from the reading.

**850. Atmospheric Pressure.**—The atmospheric pressure is everywhere present, and presses all objects in all directions with equal force. If a book is laid upon the table, the air presses upon it in every direction with an equal average force of 14.7 pounds per square inch. It would seem as though it would take considerable force to raise a book from the table, since, if the size of the book were 8 inches by 5 inches, the pressure upon it is  $8 \times 5 \times 14.7 = 588$  pounds; but there is an equal pressure beneath the book to counteract the pressure on the top. It would now seem as though it would require a great force to open the book, since there are two pressures of 588 pounds each, acting in opposite directions, and tending to crush the book; so it would but for the fact that there is a layer of air between each leaf acting upwards and downwards with a pressure of 14.7 pounds per square inch. If two metal plates be made as perfectly smooth and flat as it is possible to get them, and the edge of one be laid upon the edge of the other, so that one may be slid upon the other, and thus exclude the air, it will take an immense force, compared with the weight of the plates, to separate them. This is because the full pressure of 14.7 pounds per square inch is then exerted upon each plate, with no counteracting equal pressure between them.

If a piece of flat glass be laid upon a flat surface that has been previously moistened with water, it will require considerable force to separate them; this is because the water

excludes the air between the flat surface and glass, and any attempt to separate these causes a partial vacuum between the glass and the surface, thereby reducing the counter pressure beneath the glass.

**851. Tension of Gases.**—In Fig. 110 the space above the column of mercury was said to be a vacuum, and that if any gas or air was present it would expand, its tension forcing the column of mercury downwards. If enough gas is admitted to cause the mercury to stand at 15 inches, the tension of the gas is evidently  $\frac{14.7}{2} = 7.35$  pounds per square inch, since the pressure of the outside air of 14.7 pounds per square inch balances only 15 inches instead of 30 inches of mercury; that is, it balances only half as much as it would if there were no gas in the tube; therefore, the tension (pressure) of the gas in the tube is 7.35 pounds. If more gas is admitted, until the top of the mercurial column is just level with the mercury in the cup, the gas in the tube has then a tension equal to the outside pressure of the atmosphere. Suppose that the bottom of the tube is fitted with a piston, and that the total length of the inside of the tube is 36 inches. If the piston be shoved upwards so that the space occupied by the gas is 18 inches long instead of 36 inches, the temperature remaining the same as before, it will be found that the tension of the gas within the tube is 29.4 pounds. It will be noticed that the volume occupied by the gas is only half that in the tube before the piston was moved, while the pressure is twice as great, since  $14.7 \times 2 = 29.4$  pounds. If the piston be shoved up, so that the space occupied by the gas is only 9 inches instead of 18 inches, the temperature still remaining the same, the pressure will be found to be 58.8 pounds per square inch. The volume has again been reduced one-half, and the pressure increased two times, since  $29.4 \times 2 = 58.8$  pounds. The volume now occupied by the gas is 9 inches long, whereas, before the piston was moved, it was 36 inches long; as the tube was assumed to be of uniform diameter throughout its length, the volume is now  $\frac{9}{36} = \frac{1}{4}$  of its original volume,

and its pressure is  $\frac{58.8}{14.7} = 4$  times its original pressure.

Moreover, if the temperature of the confined gas remains the same, the pressure and volume will always vary in a similar way. The law which states these effects is called *Mariotte's law*.

**852. Mariotte's Law.**—*The temperature remaining the same, the volume of a given quantity of gas varies inversely as the pressure.*

The meaning of this is: If the volume of the gas is diminished to  $\frac{1}{2}$ ,  $\frac{1}{3}$ ,  $\frac{1}{5}$ , etc., of its former volume, the tension will be increased 2, 3, 5, etc., times, or, if the outside pressure be increased 2, 3, 5, etc., times, the volume of the gas will be diminished to  $\frac{1}{2}$ ,  $\frac{1}{3}$ ,  $\frac{1}{5}$ , etc., of its original volume, the temperature remaining constant. It also means that if a gas is under a certain pressure, and the pressure is diminished to  $\frac{1}{2}$ ,  $\frac{1}{3}$ ,  $\frac{1}{10}$ , etc., of its original pressure, that the volume of the confined gas will be increased 2, 4, 10, etc., times—its tension decreasing at the same rate.

Suppose 3 cubic feet of air to be under a pressure of 60 pounds per square inch in a cylinder fitted with a movable piston; then the product of the volume and pressure is  $3 \times 60 = 180$ . Let the volume be increased to 6 cubic feet, then the pressure will be 30 pounds per square inch, and  $30 \times 6 = 180$  as before. Let the volume be increased to 24 cubic feet, it is then  $\frac{2}{3}$  = 8 times its original volume, and the pressure is  $\frac{1}{8}$  of its original pressure, or  $60 \times \frac{1}{8} = 7\frac{1}{2}$  pounds, and  $24 \times 7\frac{1}{2} = 180$ , as in the two preceding cases. It will now be noticed that if a gas be enclosed within a confined space, and allowed to expand without losing any heat, *the product of the pressure and the corresponding volume for one position of the piston is the same as for any other position of the piston*. If the piston was to compress the air, the rule would still hold good.

Let  $p$  = pressure for one position of the piston;

$p_1$  = pressure for any other position of the piston;

$v$  = volume corresponding to the pressure  $p$ ;

$v_1$  = volume corresponding to the pressure  $p_1$ .

Then,  $p v = p_1 v_1; \quad (6.)$

also,  $p_1 = \frac{p v}{v_1}; \quad (7.)$

and  $v_1 = \frac{p v}{p_1}. \quad (8.)$

Knowing the volume and the pressure for any position of the piston and the volume for any other position, the pressure may be calculated by formula 7, or if the pressure is known for any other position, the volume may be calculated by formula 8.

EXAMPLE.—If 1.875 cubic feet of air be under a pressure of 72 pounds per square inch, (a) what will be the pressure when the volume is increased to 2 cubic feet? (b) to 3 cubic feet? (c) to 9 cubic feet?

SOLUTION.—(a)  $p_1 = \frac{p v}{v_1} = \frac{72 \times 1.875}{2} = 67\frac{1}{2}$  pounds per square inch. Ans.

(b)  $p_1 = \frac{72 \times 1.875}{3} = 45$  pounds per square inch. Ans.

(c)  $p_1 = \frac{72 \times 1.875}{9} = 15$  pounds per square inch. Ans.

EXAMPLE.—If 10 cubic feet of air have a tension of 5.6 pounds per square inch, (a) what is the volume when the tension is 4 pounds? (b) 8 pounds? (c) 25 pounds? (d) 100 pounds?

SOLUTION.—(a)  $v_1 = \frac{p v}{p_1} = \frac{5.6 \times 10}{4} = 14$  cubic feet. Ans.

(b)  $v_1 = \frac{5.6 \times 10}{8} = 7$  cubic feet. Ans.

(c)  $v_1 = \frac{5.6 \times 10}{25} = 2.24$  cubic feet. Ans.

(d)  $v_1 = \frac{5.6 \times 10}{100} = .56$  cubic foot. Ans.

As a necessary consequence of Mariotte's law, it may be stated that *the density of a gas varies directly as the pressure and inversely as the volume; that is, the density increases as the pressure increases, and decreases as the volume increases.*

This is evident, since if a gas has a tension of two atmospheres, or  $14.7 \times 2 = 29.4$  pounds per square inch, it will weigh twice as much as the same volume would if the



tension was one atmosphere, or 14.7 pounds per square inch. For, let the volume be increased until it is twice as great as the original volume, the tension will then be one atmosphere. The total weight of the gas has not been changed, but there are now 2 cubic feet for every 1 cubic foot of the original volume, and the weight of one cubic foot now is only half as great as before. Thus, the density decreases as the volume increases, and as an increase of pressure causes a decrease of volume, the density increases as the pressure increases.

Let  $D$  be the density corresponding to the pressure  $p$  and volume  $v$ , and  $D_1$  be the density corresponding to the pressure  $p_1$  and volume  $v_1$ ; then,

$$p : D :: p_1 : D_1, \text{ or } p D_1 = p_1 D, \quad (9.)$$

$$\text{and } v : D_1 :: v_1 : D, \text{ or } v D = v_1 D_1. \quad (10.)$$

Since the weight is proportional to the density, the weights may be used in place of the densities in formulas 9 and 10. Thus, let  $W$  be the weight of a quantity of air or other gas whose volume is  $v$  and pressure is  $p$ ; let  $W_1$  be the weight of the same quantity when the volume is  $v_1$  and pressure is  $p_1$ ; then,

$$p : W :: p_1 : W_1, \text{ or } p W_1 = p_1 W, \quad (11.)$$

$$v : W_1 :: v_1 : W, \text{ or } v W = v_1 W_1. \quad (12.)$$

**EXAMPLE.**—The weight of 1 cubic foot of air at a temperature of 60° F. and under a pressure of 1 atmosphere (14.7 pounds per square inch) is .0763 pound; what would be the weight per cubic foot if the volume was compressed until the tension was 5 atmospheres, the temperature still being 60°?

**SOLUTION.**—Using formula 11,

$$p : W :: p_1 : W_1, \text{ or } 1 : .0763 :: 5 : W_1, \text{ or } W_1 = .3815 \text{ lb. Ans.}$$

**EXAMPLE.**—If in the last example the air had expanded until the tension was 5 pounds per square inch, what would have been its weight per cubic foot?

**SOLUTION.**—Here  $p = 14.7$ ,  $p_1 = 5$ , and  $W = .0763$ . Hence, using the same formula,  $14.7 : .0763 :: 5 : W_1$ , or  $W_1 = .02595$  lb. Ans.

**EXAMPLE.**—If 6.75 cubic feet of air at a temperature of 60° F., and a pressure of one atmosphere, are compressed to 2.25 cubic feet (the temperature still remaining 60° F.), what is the weight of a cubic foot of the compressed air?

SOLUTION.—Using formula 12,

$$v : W_1 :: v_1 : W, \text{ or } 6.75 : W_1 :: 2.25 : .0763,$$

$$\text{or } W_1 = \frac{.0763 \times 6.75}{2.25} = .2289 \text{ lb. Ans.}$$

**853. Relation of Temperature to Volume.**—In all that has been said before, it has been stated that the temperature was constant; the reason for this will now be explained: Suppose 5 cubic feet of air to be confined in a cylinder whose area is 10 square inches, placed in a vacuum so that there will be no pressure due to the atmosphere, and the cylinder be fitted with a piston weighing, say, 100 pounds. The tension of the gas will be  $\frac{100}{10} = 10$  pounds per square inch. Suppose that the temperature of the air is  $32^\circ$  F., and that it is heated until the temperature is  $33^\circ$  F., or the temperature is increased  $1^\circ$ ; it will be found that the piston has risen a certain amount, and, consequently, the volume has increased, while the pressure is the same as before, or 10 pounds per square inch. If more heat is applied until the temperature of the gas is  $34^\circ$  F., it will be found that the piston has again risen and the volume again increased, while the pressure still remains the same. It will be found that for every increase of temperature, there will be a corresponding increase of volume. The law which expresses this change is called *Gay-Lussac's law*.

**854. Gay-Lussac's Law.**—*If the pressure remains constant, every increase of temperature of  $1^\circ$  F. produces in a given quantity of gas an expansion of  $\frac{1}{459}$  of its volume at  $32^\circ$  F.*

If the pressure remains constant, it will also be found that every decrease of temperature of  $1^\circ$  F. will cause a decrease of  $\frac{1}{459}$  of the volume at  $32^\circ$  F.

Let  $v$  = volume of gas before heating;

$v_1$  = volume of gas after heating;

$t$  = temperature corresponding to volume  $v$ ;

$t_1$  = temperature corresponding to volume  $v_1$ .

$$\text{Then, } v_1 = v \left( \frac{459 + t_1}{459 + t} \right). \quad (13.)$$

That is, *the volume of gas after heating (or cooling) equals the original volume multiplied by 459 plus the final temperature, divided by 459 plus the original temperature.*

EXAMPLE.—When 5 cubic feet of air at a temperature of 45° are heated under constant pressure up to 177°, what is its new volume?

SOLUTION.—Applying formula 13,

$$v_1 = v \left( \frac{459 + t_1}{459 + t} \right) = 5 \times \left( \frac{636}{504} \right) = 6.309 \text{ cu. ft.}$$

Suppose that a certain volume of gas is confined in a vessel so that it can not expand; in other words, suppose that the piston of the cylinder before mentioned to be fastened so that it can not move. Let a gauge be placed on the cylinder so that the tension of the confined gas can be registered. If the gas is heated, it will be found that for every increase of temperature of 1° F. there will be a corresponding increase of  $\frac{1}{459}$  of the tension at 32° F.; that is, the volume remaining constant, the tension increases  $\frac{1}{459}$  of the tension at 32° F. for every degree rise of temperature.

Let  $p$  = the original tension;  
 $t$  = the corresponding temperature;  
 $t_1$  = any higher temperature;  
 $p_1$  = corresponding tension.

$$\text{Then, } p_1 = p \left( \frac{459 + t_1}{459 + t} \right). \quad (14.)$$

That is, *if a certain quantity of gas is heated from  $t^\circ$  to  $t_1^\circ$ , the volume remaining constant, the resulting tension  $p_1$  will be equal to the original tension multiplied by 459 plus the final temperature, divided by 459 plus the original temperature.*

EXAMPLE.—If a certain quantity of air is heated under constant volume from 45° to 177°, what is the resulting tension, the original tension being 14.7 pounds per square inch?

SOLUTION.—Using formula 14,

$$p_1 = p \left( \frac{459 + t_1}{459 + t} \right) = 14.7 \times \left( \frac{636}{504} \right) = 18.55 \text{ lb. per sq. in.}$$

**855. Absolute Zero.**—According to the modern and now generally accepted theory of heat, the atoms and

molecules of all bodies are in an incessant state of vibration. The vibratory movement in the liquids is faster than in the solids; it is faster in the gases than in either of the others. Any increase of heat increases the vibrations, and a decrease of heat decreases them. From experiments and calculations based upon higher mathematics, it has been concluded that at  $459^{\circ}$  below zero on the Fahrenheit scale, or at  $273^{\circ}$  below zero on the Centigrade scale, all these vibrations cease. This point is called the *absolute zero*, and all temperatures reckoned from this point are called the *absolute temperatures*. The point of absolute zero has never been reached nor closely approached, the lowest recorded temperature being  $360^{\circ}$  F. below zero, but, nevertheless, it has a meaning, and is used in many formulas, being nearly always denoted by  $T$ . Ordinary temperatures are denoted by  $t$ . When the word temperature alone is used, the meaning is the same as ordinarily used, but when absolute temperature is specified,  $459^{\circ}$  F. must be added to the temperature. The absolute temperature corresponding to  $212^{\circ}$  F. is  $459^{\circ} + 212^{\circ} = 671^{\circ}$  F. If the absolute temperature is given, the ordinary temperature may be found by subtracting  $459^{\circ}$  from the absolute temperature. Thus, if the absolute temperature is  $520^{\circ}$  F., the temperature is  $520^{\circ} - 459^{\circ} = 61^{\circ}$  F.

Let  $P$  = pressure per square inch;  
 $V$  = volume of air in cubic feet;  
 $T$  = absolute temperature;  
 $W$  = weight.

$$\text{Then, } P = \frac{.37052 WT}{V}; \quad (15.)$$

$$V = \frac{.37052 WT}{P}; \quad (16.)$$

$$T = \frac{PV}{.37052 W}; \quad (17.)$$

$$W = \frac{PV}{.37052 T}. \quad (18.)$$

NOTE.—The constant .37052 is the reciprocal of the weight, in pounds, of 1 cubic foot of air at  $1^{\circ}$  absolute temperature (Fahr.), and a pressure of 1 pound per square inch.

**EXAMPLE.**—If 40 cubic feet of air weigh 3.5 pounds, and have a temperature of 82°, what is the pressure (tension) in pounds per square inch?

**SOLUTION.**—  $P = \frac{.37052 WT}{V} = \frac{.37052 \times 3.5 \times 541}{40} = 17.539$  lb. per sq. in. Ans.

**EXAMPLE.**—What is the volume in cubic feet of a certain quantity of air having a tension of 17.539 pounds per square inch, a temperature of 80°, and which weighs 3.5 pounds?

**SOLUTION.**—  $V = \frac{.37052 WT}{P} = \frac{.37052 \times 3.5 \times 541}{17.539} = 40$  cu. ft. Ans.

**EXAMPLE.**—If 40 cubic feet of air having a tension of 17.539 pounds per square inch weigh 3.5 pounds, what is the temperature?

**SOLUTION.**—  $T = \frac{PV}{.37052 W} = \frac{17.539 \times 40}{.37052 \times 3.5} = 541^\circ$ , nearly. Hence,  $541^\circ - 459^\circ = 82^\circ$ . Ans.

**EXAMPLE.**—If 40 cubic feet of air have a tension of 17.539 pounds per square inch, and a temperature of 82°, (a) what is its weight? (b) what is its weight per cubic foot?

**SOLUTION.**—(a)  $W = \frac{PV}{.37052 T} = \frac{17.539 \times 40}{.37052 \times 541} = 3.5$  lb. Ans.

(b)  $3.5 \div 40 = .0875$  lb. per cu. ft. Ans.

**856. Mixing of Gases.**—If two liquids which do not act chemically upon each other are mixed together and allowed to stand, it will be found that after a time the two liquids have separated, and the heavier has fallen to the bottom. If two vessels containing gases of different densities be put in communication with each other, the gases will mingle freely together till the mixture is uniform in each vessel. If one vessel be above the other, and the heavier gas be in the lower vessel, the same result will occur. The greater the difference of the densities of the gases, the quicker a uniform mixture will be formed, assuming that no chemical action takes place between the gases. When the gases have the same temperature and pressure, the pressure of the mixture will be the same; this is evident, since the total volume has not been changed, and unless the volume or temperature changes, the pressure can not change. This property of the mixing of gases is a very valuable one, since, if they acted like liquids, carbonic acid gas (the result of

combustion), which is  $1\frac{1}{2}$  times as heavy as air, would remain next to the earth, instead of dispersing into the atmosphere, the result being that no animal life could exist.

**Mixtures of Equal Volumes of Gases Having Unequal Pressures.**—*If two gases having the same volume and temperature, but different pressures, be mixed in a vessel whose volume equals one of the equal volumes of the gas, the pressure of the mixture will be equal to the sum of the two pressures, provided that the temperature remains the same as before.*

**EXAMPLE.**—Two vessels containing 8 cubic feet of gas, each at a temperature of  $60^\circ$ , and at a pressure of 40 pounds and 25 pounds per square inch, respectively, are placed in communication with each other, and all the gas is compressed into one vessel. If the temperature of the mixture is also  $60^\circ$ , what is the pressure?

**SOLUTION.**—According to the law just given, the pressure will be  $40 + 25 = 65$  lb. per sq. in.

### 857. Mixture of Two Gases Having Unequal Volumes and Pressures.—

Let  $v$  and  $p$  be the volume and pressure of one of the gases.  
Let  $v_1$  and  $p_1$  be the volume and pressure of the other gas.  
Let  $V$  and  $P$  be the volume and pressure of the mixture.

Then, if the temperature remains the same,

$$P = \frac{pv + p_1v_1}{V}. \quad (19.)$$

$$V = \frac{pv + p_1v_1}{P}. \quad (20.)$$

**EXAMPLE.**—Two gases of the same temperature, having volumes of 7 cubic feet and  $4\frac{1}{2}$  cubic feet, and tensions of 25 pounds and 18 pounds per square inch, respectively, are mixed together in a vessel whose volume is 10 cubic feet. The temperature remaining the same, what is the resulting pressure?

**SOLUTION.**—  $P = \frac{pv + p_1v_1}{V} = \frac{(25 \times 7) + (18 \times 4\frac{1}{2})}{10} = \frac{256}{10} = 25.6$  lb. per sq. in. Ans.

**EXAMPLE.**—What must be the volume of a vessel which will hold two gases whose volumes are 7 cubic feet and  $4\frac{1}{2}$  cubic feet, and whose

tensions are 25 pounds and 18 pounds per square inch, respectively, in order that the pressure may be 25.6 pounds per square inch, the temperature remaining the same throughout?

$$\text{SOLUTION.} \quad V = \frac{p v + p_1 v_1}{P} = \frac{(25 \times 7) + (18 \times 4\frac{1}{2})}{25.6} = 10 \text{ cu. ft. Ans.}$$

#### GASES COMMON TO MINES.

**858.** The gases met with in mines are comparatively few in number, but a thorough knowledge of their properties and the manner of their detection is most important. The following are the gases most commonly occurring in mines, considered in the order of their importance, as dangerous to life and health.

**Marsh-gas** (carbureted hydrogen) ( $CH_4$ ). Sp. Gr., 0.559.

**Marsh-gas** (mixed with air)—**Firedamp** (Saturated). Sp. Gr., 0.96.

**Carbonic oxide gas** ( $CO$ )—**White damp**. Sp. Gr., 0.967.

**Carbonic acid gas** ( $CO_2$ )—**Black damp**. Sp. Gr., 1.5291.

$\left. \begin{array}{l} \text{Carbonic acid gas} \dots (CO_2) \\ \text{Carbonic oxide gas} \dots (CO) \\ \text{Nitrous oxide gas} \dots (N_2O) \\ \text{Nitrogen (free)} \dots (N) \\ \text{Hydrogen (free)} \dots (H) \\ \text{Watery vapor} \dots (H_2O) \end{array} \right\}$	<p style="text-align: center;"><b>After-damp.</b></p> <p>(Composition very variable.)</p>
-----------------------------------------------------------------------------------------------------------------------------------------------------------------------------------------------------------------------------------------------------------------------------------	-------------------------------------------------------------------------------------------

**Sulphureted hydrogen** ( $H_2S$ )—**Stink damp**. Sp. Gr., 1.1912.

**Ethene, or olefiant gas** ( $C_2H_4$ ). Sp. Gr., 0.973.

The two latter gases are rarely found in mines, and when present are only in limited volumes.

**859. Marsh-gas** ( $CH_4$ ).—This is the most disastrous, in its effects, of any of the gases known to mining.

(a) **Occurrence.**—Pure marsh-gas ( $CH_4$ ), Sp. Gr., 0.559, exists, or *has existed*, as an occluded gas, to a greater

or less extent, in all coal formations, and is a product of the early metamorphism of vegetable matter under the water and superimposed strata, by which all air was excluded. Marsh-gas is often seen rising in bubbles from the bottom of stagnant pools; it is always the product of the decomposition of vegetable matter, away from air, and in the presence of water. When such decomposition of vegetable matter occurs in a *dry* place, away from air, ethene, or olefiant gas ( $C_2H_4$ ), which is richer in carbon than marsh-gas, is formed.

Marsh-gas transpires from the pores, foliations, and crevices of a freshly exposed face of a gaseous coal-seam. It may also issue from the floor or roof of the seam, as stratigraphical or other conditions may have rendered these adjacent strata more pervious to the gas than the coal-seam itself. It may transpire from the entire face, or may issue in a stronger flow from a crevice or *feeder*. It may even find vent as a *blower* of gas, under great pressure. Natural marsh-gas never occurs in a pure state, but is always mixed with other gases. The mode of occurrence of these gases will be further explained in the study of *Diffusion*, *Occlusion*, and *Transpiration*.

(b) **Properties.**—Marsh-gas is a combustible gas, burning with a bluish flame, but it will not support combustion. It is slightly more than one-half as heavy as air of the same temperature and pressure. Upon first transpiring from the face, or issuing from the fissures of a formation, the gas diffuses rapidly in the air, until its limit of diffusion is reached in a confined space, as in the still air of a mine.

Marsh-gas is the lightest of the hydrocarbons, a molecule of marsh-gas consisting of *one* atom of carbon united to *four* atoms of hydrogen. It is an odorless, colorless, and tasteless gas. It does not poison the animal system; a person may breathe with impunity air containing a large percentage of the gas for a considerable time.

One of the most important properties of marsh-gas, to the miner, is that which it possesses of not igniting immediately upon contact with flame. Ignition of the gas takes place



only after the lapse of an appreciable period of time, which, although but a fraction of a second, is sufficient to render the use of many detonating explosives safe in presence of firedamp, the detonation in this class of explosives being instantaneously followed by a period of extreme cold.

(c) **Detection of Marsh-Gas.**—On account of the rapid diffusibility of marsh-gas (Table 19), its detection in the mine is practically the detection of firedamp. (See Detection of Firedamp.)

**860. Firedamp.**—Any explosive mixture of marsh-gas and air is termed *firedamp*.

(a) **Occurrence.**—On account of the high diffusive power of marsh-gas, *firedamp* is formed very rapidly wherever marsh-gas issues from the coal or strata. This diffusion takes place upon the outer envelope of the gas in contact with the air. A considerable body of the gas, owing to its lighter weight and warmer temperature, ascends and flows along the roof, collecting in cavities and convenient places for lodgment. The specific gravity of this diffusing gas approaches that of air, and its subsequent diffusion is slow. For this reason, we look for firedamp in the cavities of the roof and the higher working-places of the mine.

(b) **Properties.**—The explosive limits of firedamp mixtures can not be closely defined, as such conditions as the purity of the marsh-gas, and the pressure to which the firedamp is subjected, vary the explosive points slightly. However, under ordinary conditions, when 1 part of marsh-gas mixes with  $5\frac{1}{2}$  parts of air, the combination is at its lowest explosive limit. As the proportion of air is increased, the explosive violence grows steadily greater till it reaches a maximum, when the mixture is in the proportion of  $9\frac{1}{2}$  parts of air to 1 of gas. From this point, as the proportion of air is increased, the explosive violence grows more and more feeble till the mixture consists of 13 parts of air to 1 of gas, when explosion ceases altogether.

The percentage of marsh-gas in an atmosphere of fire-damp, when at its lowest explosive limit, is calculated thus :

Relative volume of gas,	1
Relative volume of air,	5.5
Relative volume of mixture,	6.5

and  $\frac{1 \times 100}{6.5} = 15.38$  per cent. of marsh-gas.

In like manner, for the higher explosive limit, we have

Relative volume of gas,	1
Relative volume of air,	13
Relative volume of mixture,	14

and  $\frac{1 \times 100}{14} = 7.14$  per cent. of marsh-gas.

The presence in firedamp of  $\frac{1}{4}$  of its volume of carbonic acid gas will render it inexplusive.

The effect of an increase of pressure upon the explosive range of gas is to extend it. A mixture of marsh-gas and air that is below or above the explosive limits, is often rendered explosive by an increase of pressure. This may often occur in proximity to a blast when the air of the workings would otherwise be safe.

The effect of suspended coal-dust in the air is to widen the explosive range. This is probably due to the increase of temperature incident to the burning of the gases distilled from the dust.

(c) **Detection of Firedamp.**—The detection of this gas in the mine is to be entrusted to the most experienced men only, for it is fraught with danger to all in the mine. Many devices have been invented for the purpose of detecting the presence of gas, as well as to determine at the same time the approximate percentage of the mixture of gas and air. Any machine to be of practical value in this line, must be capable of making the test promptly and safely at the point of danger, and of revealing the presence of  $\frac{1}{4}$  per cent. of gas.

We shall refer more particularly to the means at our

disposal for detecting firedamp later, and shall describe the various forms of lamps in common use. We will state here, that, at the present time, no machine or device for testing has given satisfaction equal to the safety-lamp, which is prompt and always at hand. The lamp is elevated cautiously to the place where gas is suspected, care being taken to keep the lamp in an upright position, that its flame may not approach the gauze of the lamp. If gas is present, it will enter the lamp with the air, and will burn when present in large quantities, filling the whole lamp with flame. If the percentage of gas in the air is small, however, say two per cent., its presence is manifested only by a small blue tip to the flame of the lamp, which may be seen more distinctly by screening the eyes from the brighter portion of the flame with the hand.

An experienced and careful observer will detect, with the ordinary lamp, a percentage of the gas as low as 2 per cent. It is, however, often desirable to detect the presence of smaller quantities than this in the air of dusty mines, where the coal-dust is highly inflammable. For this purpose, specially constructed lamps are used. In the use of the lamp for the detection of presence of gas, care must be taken to make no quick movement; especially is this needful in case of flaming in the lamp. The lamp must be immediately removed from the gas, but not so quickly as to blow the flame through the gauze. This requires much self-possession on the part of the observer.

**861. White Damp (CO).**—The “white damp” of the mines is carbonic oxide gas. It is a dangerous gas, because of its harmful effects and its unsuspected presence.

(a) **Occurrence.**—Carbonic oxide gas is a product of the incomplete combustion of carbonaceous fuel, the supply of air being limited. Thus, it is produced largely by the slow combustion of coal in the gob, by mine fires, and by the explosion of powder.

(b) **Properties.**—This gas is a colorless, odorless, and

tasteless gas. It is somewhat lighter than air at the same temperature and pressure. It burns with a pale, violet flame, like that which may be seen at any time over a freshly fed anthracite fire. It is very poisonous to the system when inhaled, being rapidly absorbed by the blood, and it acts as a narcotic, producing drowsiness or stupor, followed by acute pains in the head, back, and limbs, and afterwards by delirium. If the victim of this gas is not rescued soon, death will inevitably result.

Carbonic oxide gas has the widest explosive range of any gas except hydrogen. When 1 volume of the gas is mixed with about 6.7 volumes of air, the lowest explosive mixture is obtained. From this point it continues to be explosive until the proportion of gas is increased to the extent of 1 volume of gas to every 1.6 volumes of air. It is this property of carbonic oxide gas which makes it such an active agent in the transmission of the flame of a mine explosion from one point in the mine workings to another seemingly isolated point. Under ordinary conditions, however, this gas is not present in sufficient quantity to yield an explosive mixture.

(c) **How Detected.**—Carbonic oxide gas may be detected in the mine workings by its effect upon the flame of an ordinary lamp. The flame is much brighter and reaches upward, and it is thus lengthened out into a more or less slim, quivering taper with a bluish tip, which may be seen more clearly by screening the eyes from the brighter portion of the flame with the hand.

**862. Black Damp ( $CO_2$ ).**—The “black damp” of the mines, or, as it is often called, “choke-damp,” is carbonic acid gas. It is not as dangerous as either of the preceding gases, because its presence in the mine workings is at once manifested by the dimness of the lamps.

(a) **Occurrence.**—This gas is always a product of combustion in the presence of a plentiful supply of air. It is produced by the burning of lamps, breathing of men and

animals, decomposition and decay, and is a later product of all explosions of powder and gas. The principal source, however, is water from the coal and strata which hold it in solution, and from which it escapes as the water evaporates.

(b) **Properties.**—This is a colorless and odorless gas, but it possesses a distinctly sharp taste in the mouth when breathed. It is one-half again as heavy as air at the same temperature and pressure, and, therefore, collects near the floor and in the low places in the mine. It is incom-  
bustible, and, when present in the air to any considerable extent, extinguishes lamps. It acts as a narcotic, and produces, after a time, headache and nausea, causing death by suffocation.

(c) **How Detected.**—The presence of carbonic acid gas is readily detected by the flame of a lamp becoming reduced in size, and, when more gas is present, by its extinguishment; by lime-water, which, when exposed to the gas, becomes milky in appearance; and by damp, blue litmus paper, which becomes red when exposed in an atmosphere containing carbonic acid gas. The flame becomes reduced in size, and, when more gas is present, is extinguished altogether. Being heavier than air, it must be sought for at the floor of the entries and in the low parts of the mine.

**863. (a) Traces of Sulphureted Hydrogen Gas ( $H_2S$ ).**—This gas, though not commonly occurring in troublesome quantities, is yet a very dangerous gas to meet. It is heavier than air, having a specific gravity of 1.1912. It is violently explosive when mixed with air of about seven times its volume. The gas is very poisonous when inhaled. In small quantities in the air, it produces derangement of the system; when inhaled in larger quantities, it rapidly produces unconsciousness and prostration. The smell of the gas affords the best index of its presence, which has given rise to its being termed "*stink damp*" by the miners, for it smells like rotten eggs.

(b) **Ethene, or Olefant Gas** ( $C_2H_4$ ).—This gas occurs in varying amounts as a constituent of marsh-gas. It is this gas which causes the flame of marsh-gas to burn with some luminosity. It is a product of the dry decomposition of vegetable matter and the distillation of coal.

---

#### OTHER PROPERTIES OF GASES.

**854. Diffusion.**—All gases which do not act chemically on each other, especially air and gases of *different densities*, when in proximity, tend to *diffuse* into each other; that is to say, their molecules pass freely among each other, and tend to form a complete intermixing of the two gases. This property is called *diffusion*, and is caused by the lack of equilibrium between the molecular vibrations of the two masses; so that the molecules of the two masses tend to thoroughly intermingle. (See Art. 856.)

**865. Rate of Diffusion.**—The diffusion of gases takes place much more rapidly in a moving current than in still air. The relative rates or velocities of the diffusion of the gases into each other are in the inverse ratio of the square roots of their densities. For example, taking the density of air as 1, then the density of hydrogen gas, by Table 19, is .0693, and the square root of .0693 by the table is .2632; therefore, the relative velocity of the diffusion of hydrogen gas into air will be  $\frac{1}{\sqrt{.0693}} = \frac{1}{.2632} = 3.7987$ . This corresponds with the results given in the third column of the table; and the use of the table may be understood in this way. In all cases, divide 1 by the square root given in the second column of the table, and the quotient will be the relative velocity of the diffusion of the gas in question into air. For example, the square root of the density of marsh-gas is given in the second column as .7477; then,  $\frac{1}{.7477} = 1.3375$  = the relative velocity of the diffusion of marsh-gas into air. The annexed table of densities shows the

comparative rates of diffusion of the various gases and air into a vacuum:

**TABLE 19.**

Gas.	Density, or Specific Gravity.	Square Root of Density.	$\frac{1}{\sqrt{\text{Density}}}$ .	Velocity of Diffusion. Air = 1.
Hydrogen .....	0.0693	0.2632	3.7987	3.830
Marsh-gas .....	0.5590	0.7477	1.3375	1.344
Carbonic oxide .....	0.9670	0.9834	1.0169	1.015
Nitrogen .....	0.9713	0.9855	1.0147	1.014
Oxygen.....	1.1057	1.0515	0.9510	0.949
Sulphureted hydro- gen.....	1.1912	1.0914	0.9163	0.950
Carbonic acid.....	1.5291	1.2366	0.8087	0.812

The values given in the last column of this table were obtained by experimenting with the gases, and agree quite closely with the calculated values given in the preceding column. From the last column we see that 1,344 volumes of marsh-gas will diffuse in the same time as 1,000 volumes of air or 812 volumes of carbonic acid gas.

**836. Occlusion of Gases.**—A gas is *occluded* (hidden) when it exists in the pores of a solid mass. A familiar example of the occlusion of gases is found in the coal-seams, where gases often exist in large quantities and are a source of danger in mining.

The conditions which have held these gases in the coal and adjoining strata, till set free by the penetration of mine workings, are largely a close coal and an impervious roof and floor. The kind and amount of gases occluded in different coal-seams, and even in different parts of the same seams, vary much, and alter, to a large extent, the character of the coal enclosing them.

The gases most commonly occluded in coal-seams are marsh-gas, nitrogen, carbonic acid gas and traces of oxygen, carbonic oxide, ethene, and some other hydrocarbons.

The relative percentages of these gases vary largely, even in freshly mined coals.

**867. Pressure of Occluded Gases.**—The pressure of occluded gases has been shown, by a number of experiments in England, France, and Belgium, to reach as high as 10 and 16 atmospheres; and, in exceptional cases, 32 atmospheres has been the recorded pressure. Whatever degree of exactness these experiments may have, they serve to show, at least, the enormous pressures under which occluded gases may be projected from a newly exposed face. In some instances, this flow of natural gas from certain veins has furnished fuel for extensive steam plants. In general, the tapping of a gaseous seam relieves the pressure, after a limited time, by the escape of the gas.

The pressure of occluded gases is often manifested in a newly exposed face of coal by a sharp cracking and hissing sound, throwing the splintered coal with considerable violence into the face of the miner.

**868. Transpiration of Gases from Coal.**—When a coal-seam containing occluded gases is being worked, the pressure on the gas drives it outwards from the coal, and often from the roof and floor of the seam. The regular emission of gas from a solid mass in which it was contained is called *transpiration*.

**869. Feeders and Blowers.**—Wherever a cavity, crevice, or fissure exists in proximity to or in connection with a gaseous seam, it becomes charged with the occluded gases of the seam, under the same pressure. A dangerous reservoir of gas is thus formed, which may at any moment be pierced or tapped by the pick or drill of the miner and discharge its contents into the mine workings. Such *cavities*, *crevices*, or *fissures* charged with gas are termed "*feeders*," and, when tapped, the stream of gas issuing from them is called a "*blower*." According to the size of the internal reservoir of gas, such a blower may continue to discharge its gas, with practically no abatement, for a long time.



**870. Outbursts.**—In the working of the seams of some localities, the presence of occluded gases is frequently manifested by a violent outburst at the working face. These outbursts often take place without warning, and produce an effect similar to that of an explosion, throwing down the coal in large quantities.

The cause is due to a *feeder* finding access to a more or less vertical crevice or cleat behind the working face of the coal-seam. Its pressure thus becomes distributed over a considerable area of coal, and exerts a powerful localized force. This is due to a pressure on a large area being made to act on a small one with multiplied force.

Fig. 113 represents a dangerous pocket of gas lying beneath an impervious stratum of close-grained rock, which

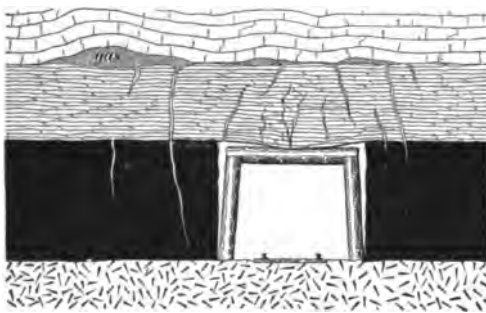

FIG. 113.

has prevented its escape. The gas is under enormous pressure, incident to the subsidence and contraction of the strata. The cleats or vertical fissures shown in the coal-seam are "face cleats," the entry or gangway

being driven "end on." The pressure of the gas causes the foliated shale to rest heavily on the timbers, and later a fissure occurs in this strata, which opens a communication for the gas with the face cleats of the coal. The pressure of the gas may thereby be distributed over a large area of the rib, with the result just described.

There are well-authenticated, although seemingly incredible, cases upon record where headings and chutes have been completely blocked by a compacted mass of from 15 to 20 tons of fine coal, thus thrown from the face without the slightest warning. In other instances, the outburst may be accompanied by a subterranean pounding, or "bumping,"

as the miners term it, or by a sudden report, similar to that of a blast. This pounding or "bumping" sometimes continues at intervals for two or three days prior to the outburst. By far the larger number of violent outbursts are of marsh-gas; although instances are recorded of very violent outbursts of carbonic acid gas.

**871. Calculation of the Initial Force of an Explosion.**—The *force* of an explosion depends upon the expansive power of the gases resulting from the explosion. The expansive power of these gases depends upon their relative volumes *before* and *after* the explosive reaction has taken place. The *initial force* of an explosion is the force developed at the moment of ignition. To calculate the initial force of an explosion, we must first determine the *relative* or *atomic volume* (Art. 841) of the resulting gases. Thus, in the *complete* explosion of marsh-gas ( $CH_4$ ), the reaction which takes place is expressed by the following equation:

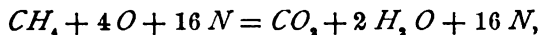

or 1 atom of carbon + 4 of hydrogen + 4 of oxygen + 16 of nitrogen = 25 atoms; and 1 atom of carbon + 2 of oxygen + 4 of hydrogen + 2 of oxygen + 16 of nitrogen = 25 atoms.

We notice in this *complete* explosion, the maximum explosive energy must be developed, because *all* of the carbon of the marsh-gas is converted immediately into carbonic acid gas, and *all* of the hydrogen into watery vapor, both of which are dead or inert products, having given out their energy. We shall also see later that this occurs when the marsh-gas forms 9.38 per cent. of the firedamp.

By observing the above equation, we see that for each molecule of  $CH_4$  there is produced *one* molecule of  $CO_2$ , and *two* molecules of  $H_2O$ . *Four* atoms of  $O$  are consumed in the reaction, which are derived from the air and represent a volume of air containing approximately 4 atoms of  $O$  and 16 atoms of  $N$ . (More accurately, the 4 atoms of  $O$  represent 20.7 per cent. of the entire air used; see Art. 845.)

Now, determining the atomic volume of the gases before and after the reaction, we find the volume of the firedamp (marsh-gas and air) is the same as the volume of the carbonic acid gas, watery vapor, and nitrogen produced; thus, the molecule of marsh-gas occupies the same space as the molecule of carbonic acid gas; the *two* molecules of watery vapor occupy the same space as the *four* atoms of oxygen. (See Second Law of Volume, Art. 841.) The nitrogen is unchanged by the reaction.

Before Explosion.				After Explosion.				
Gas.	Symbol.		Atomic or Relative Volumes.	Gas.	Symbol.		Atomic or Relative Volumes.	
Marsh-gas.	$CH_4$	1 molecule.	2	Carb. acid gas.	$CO_2$	1 molecule.	2	
Air.	{	$O$	4 atoms.	4	Watery vapor.	$2 H_2O$	2 molecules.	4
		$N$	Free nitrogen.	15.32	Nitrogen.	$N$	Free nitrogen.	15.32
Total volume, 21.32				Total volume, 21.32				

By observing the above table, we see that the column of relative volumes shows 2 volumes of marsh-gas and  $4 + 15.32 = 19.32$  volumes of air, which is in the ratio of 1 volume of marsh-gas to 9.66 volumes of air, the firedamp being at its maximum explosive point. We observe, also, by the table, that 4 volumes of oxygen are consumed in the complete explosion of 2 volumes of marsh-gas. We have previously learned (Art. 845) that oxygen forms 20.7 per cent. of the volume of the air; the remaining 79.3 per cent. being nitrogen in a free state. Hence, to find the relative volume of air per 2 volumes of gas, we write the following proportion:  $20.7 : 4 :: 100 : x = 19.32$  volumes of air, or, for 1 volume of gas, we have  $20.7 : 2 :: 100 : x =$

9.66 volumes of air. The entire relative volume of fire-damp concerned in the reaction is, then, the sum of the relative volumes (21.32 volumes), as by the table.

The percentage of pure marsh-gas in this mixture, or body of firedamp, is found thus,  $\frac{2 \times 100}{21.32} = 9.38$  per cent. of marsh-gas. There being no change in the atomic volume of these gases before and after explosion, the expansive power produced by the combustion of the mixture can be found from the increase in temperature from 60° F. (normal) to 1,200° F. (temperature of ignition for marsh-gas). Thus, the total pressure of a confined gas is always proportional to its absolute temperature. The absolute temperature is the temperature above absolute zero, which is 459° below the Fahrenheit zero. Hence, to transform Fahrenheit temperature to absolute temperature we add 459 degrees. Then, knowing the pressure of the atmosphere to be 14.7 at the normal temperature 60° F., we write the simple proportion

$$459 + 60 : 459 + 1,200 :: 14.7 : x,$$

$$\text{or, } 519 : 1,659 :: 14.7 : x = 47.0 \text{ pounds, nearly.}$$

Therefore, the absolute pressure (or the pressure above vacuum), after the explosion, is practically 47 pounds, and the ruptive pressure is 47.0 - 14.7 (or the atmospheric pressure) = 32.3 pounds per square inch.

**872. Calculation of the Weight of a Gas.**—*The weight of any gas, at a given pressure and temperature, is equal to the weight of an equal volume of air, at the same pressure and temperature, multiplied by the specific gravity of the gas.*

Let  $W$  = weight in pounds;

$V$  = volume in cubic feet;

$B$  = barometric pressure in inches;

$D$  = specific gravity of the gas—found in Table 19;

$T$  = absolute temperature.

$$\text{Then, } W = \frac{1.3253 V B D}{T}. \quad (21.)$$

**EXAMPLE.**—What is the weight of 100 cubic feet of carbonic acid gas at a pressure of 31 inches of mercury and a temperature of 32° F.?

$$\text{SOLUTION.}— W = \frac{1.3253 \times 100 \times 1.5291 \times 31}{459 + 32} = 12.7947 \text{ lb. Ans.}$$

**NOTE.**—The constant 1.3253 is the weight, in pounds, of 1 cubic foot of air at 1° absolute temperature (Fahr.) and 1 inch barometric pressure.

#### EXAMPLES FOR PRACTICE.

1. Find the weight of 200 cubic feet of marsh-gas ( $CH_4$ ), at a temperature of 70° and a pressure of 30 inches of mercury. Ans. 8.4028 lb.

2. Referring to example 1, what is the weight of the hydrogen gas, in this amount of marsh-gas? Ans. 2.1007 lb.

3. In case of an explosion of firedamp in which 8.4028 pounds (example 1) of marsh-gas were concerned, all of its hydrogen combining with the oxygen of the air to form water ( $H_2O$ ), (a) what would be the weight of watery vapor resulting from the explosion? (b) What would be the weight of oxygen consumed in this part of the reaction? (See Art. 838.)

$$\text{Ans. } \begin{cases} (a) 18.9063 \text{ lb.} \\ (b) 16.8056 \text{ lb.} \end{cases}$$

4. Referring to example 3, if all of the carbon of the 8.4028 pounds (example 1) of marsh-gas, combined with the oxygen of the air to form carbonic acid gas ( $CO_2$ ), (a) what weight of carbonic acid gas would result from the explosion? (b) What would be the weight of oxygen consumed in *this* part of the reaction? (See Art. 838.)

$$\text{Ans. } \begin{cases} (a) 23.1077 \text{ lb.} \\ (b) 16.8056 \text{ lb.} \end{cases}$$

5. Referring, now, to examples 3 and 4, (a) what is the total weight of oxygen consumed in the reaction? (b) Determine the total weight of air consumed in the reaction, incident to the explosion. (See Art. 845.)

$$\text{Ans. } \begin{cases} (a) 33.6112 \text{ lb.} \\ (b) 146.1356 \text{ lb.} \end{cases}$$

6. What volume of dry air is required to completely explode 200 cubic feet of marsh-gas? (See Arts. 841 and 845.)

$$\text{Ans. } 1,932.3 \text{ cu. ft.}$$

7. Referring to example 6, if this volume of air (1,932.3 cubic feet) is consumed in the complete combustion of 200 cubic feet of marsh-gas, (a) what per cent. of the mixture (firedamp) does the marsh-gas form? (b) What volume of firedamp was exploded?

$$\text{Ans. } \begin{cases} (a) 9.38 \text{ per cent.} \\ (b) 2,132.3 \text{ cu. ft.} \end{cases}$$

### COMBUSTION.

**873. Combustion**, in its broadest sense, refers to chemical union, attended with *heat*, sometimes with *light* and *flame*. Combustion always results in a complete transformation of the body acted upon, and of the gas which *supports the combustion*, forming other gases.

**874. Oxidation**.—Oxygen gas is the great supporter of combustion; and the process of combustion is then called *oxidation*. This gas has a strong affinity for carbon and hydrogen; and, thus, we have formed two of the most commonly occurring compounds, *water* and *carbonic acid gas*. The *first* of these is as truly an essential to animal life as the *second* is an inevitable result of the same.

There are numerous other illustrations of true combustion, however, than those in which *oxygen* plays a part. For example, the burning of a lighted taper in an atmosphere of *chlorine* gas; or, the explosion of equal quantities of *hydrogen* and *chlorine* gases.

**875. Temperature of Combustion**.—Combustion may take place at any temperature; that is to say, the oxidation is often carried on slowly and at a low temperature, and the body just as truly destroyed or consumed as when the action is stronger and the temperature high enough to produce flame.

The process is then spoken of as **slow combustion**, because the action is slower, or less energetic than in **active combustion**, when flame is produced. The consuming of the animal tissues of the body is an example of *slow combustion*. The disintegration of fine coal, in the gob heaps and goaves of the mine, is followed, in time, by a slow oxidation of the coal and the formation of carbonic oxide and carbonic acid gases. This slow oxidation is as truly a form of combustion as when the coal is burned at a higher temperature and flame results.

We conclude, then, that a high *temperature* is not an essential to slow combustion. The chemical activity of any combustion will determine its initial temperature; on the

other hand, the various products of combustion have varying heat capacities (specific heats), and thereby absorb varying amounts of the initial temperature, the remaining difference being the *sensible* heat of the combustion.

**876. Spontaneous combustion** is a term applied to the sudden bursting forth of flame, or active combustion, in a body, caused by the internal generation of heat in the body itself. Spontaneous combustion is the result of slow combustion, or chemical action, the developed heat gradually increasing till ignition takes place. The production of carbonic oxide gas (*CO*) within the confines of the body, where the supply of air is limited, greatly assists ignition.

### EXPLOSIVES AND EXPLOSIONS.

**877. Explosives.**—This term refers to any chemical compound or mechanical mixture that is capable, under certain conditions of heat or shock, of exerting a powerful ruptive pressure. The common form of explosives in use is an intimate, mechanical mixture of chemical compounds, such as will readily give rise to dissociation of their respective atoms, and the rapid formation of gases, under the proper conditions. These gases, from the temperature incident to the explosion, possess an enormous expansive force, resulting in a ruptive pressure of many tons upon the square inch.

On account of the great importance of explosives in mining, and on account of their being the direct cause of a large number of mine accidents, affecting many who are in no wise to blame for their occurrence, a careful study of their nature and use is needful. We will consider, in order, the conditions incident to the explosion of a charge in a drill-hole, for the purposes of blasting.

The chief factor which determines the strength of an explosive is the rapidity of its combustion. There are two modes of propagation of the combustion of explosives, giving rise to two general classes; in the first class the propagation being slow, while in the second it is extremely rapid.

- (a) *Explosives that deflagrate.*
- (b) *Explosives that detonate.*

**878. Deflagration** is a form of combustion dependent upon the thermal conductivity of the mass. The combustion is propagated from particle to particle of the mass, much as heat travels from one end of an iron rod to the other. All the black powders furnish examples of *deflagration*. The ignition of such a powder at one point is transmitted throughout the mass with a speed dependent upon the combustibility of the powder and its thermal conductivity. Each atom burns independently, and exerts no further influence upon the surrounding atoms, except as the heat of its burning is communicated to them.

**879. Detonation.**—This form of combustion, unlike deflagration, is transmitted, with almost lightning rapidity, to every particle of the mass. The detonation of a single particle seems to exert a wave-like compression throughout the mass that causes a like detonation of the entire body. Its speed of propagation is estimated at 16,400 feet per second; so that any explosion by *detonation* is, practically, an instantaneous development of the entire expansive energy of the mass. Nitroglycerine is an example of such an explosive.

**880. Action of Explosives.**—The theory of the action of explosives is, in outline, as follows:

*Chemical action*, incident to the ignition of a charge, assisted by *heat* and *pressure*, transforms the solid explosive compound or mixture into gaseous products, developing in such transformation or *combustion* a definite number of heat units.

**881. Chemical Reaction.**—When a charge of powder is exploded in a drill-hole, the combustion which takes place is supported by the oxygen of the niter in the powder. This salt is a powerful oxidizer, and gives up its oxygen to the sulphur and carbon. A large number of gases are formed, chief among which are nitrogen, carbonic acid gas, and carbonic oxide gas. It is impossible to give any accurate analysis of the gases resulting from any one explosion. The gaseous products vary according to the pressure



under which ignition takes place, and will vary, therefore, in each individual charge. Any chemical equation, therefore, expressing the reaction which takes place must be only approximate.

**882. Black Powders.**—The better grades of the black powders are formed by the intimate mixture of 2 molecules of niter, 1 of sulphur, and 3 of fine charcoal, making the following proportions by weight:

Niter (saltpeter), (potassium nitrate) ( $KNO_3$ )	= 74.83%
Sulphur..... (S)	= 11.84%
Carbon (fine charcoal)..... (C)	= 13.33%
	<u>100.00</u>

In practice, however, the proportions are usually taken as follows:

Niter.....	75 parts.
Sulphur.....	10 parts.
Carbon.....	15 parts.
	<u>100 parts.</u>

**883. Blasting Powder.**—It is common practice, in the manufacture of *blasting* powders, to increase the amount of carbon or charcoal, while the amount of the niter is decreased. In blasting powders, the following proportions are more commonly used, although this practice varies in different localities:

Niter.....	66 parts.
Sulphur.....	10.5 parts.
Carbon.....	23.5 parts.
	<u>100 parts.</u>

Cheaper grades of blasting powders are often made by substituting sodium nitrate ( $NaNO_3$ ) for the potassium nitrate, either in part or wholly; but such substitution produces a very inferior powder. The sodium salt absorbs moisture when exposed to even the slightest dampness, and thereby causes such powders to lose much of their strength.

**884. Size of Grain.**—The size of the grain is an important factor in determining the rapidity with which the powder acts. The finer the grain, the quicker the action; and *vice versa*, the coarser the grain, the slower the action. A little study will show the need of a careful application of this principle, on the part of the miner. For example, *gunpowder* is a fine-grained powder; what is desired is the *rapid* movement of a *small* mass; hence, its action must be very rapid, and the stock of the gun must be strong enough to resist the inertia of the bullet.

On the other hand, in all kinds of blasting, a *slower movement* of a *larger mass* is desired; hence, we employ a slower powder, one whose whole expansive energy will not be developed in a single flash. We must consider, also, that the blasting of different materials requires a different action in the powder, according to the character of the material blasted. Thus, the blasting of rock requires a quicker powder than the blasting of coal, while a soft, laminated shale will yield more completely to a very slow powder. The need for this adaptation of size is obvious and reasonable.

Fig. 114 shows, approximately, the four sizes of black powder in most common use in coal-mining. These sizes



FIG. 114.

are adapted to different grades of work and a varying hardness in the coal. The smaller sizes are adapted to a hard, brittle coal, while the larger sizes are, on the other hand, adapted to a softer and tougher coal. The smaller sizes are likewise adapted to *narrow work* (entry work) and to *shooting on the solid*, while the coarser grades yield better results in *breast* and *pillar* work, where the resisting forces are not so great. The nature of the coal, the class of work, and the judgment of the miner must determine the size of

powder best adapted for his use. Many miners, however, use very poor judgment in this respect, and reap a reward in the decrease of their net earnings.

**885. "Blown-out" Shot.**—This term is applied to any blast whose energy is expended upon the air, instead of being converted into mechanical work. The intensity of the projected flame is augmented by the high temperature and pressure resulting from the unyielding character of the walls enclosing the charge.

**886. "Windy" Shot.**—This term refers to a blast whose energy is, in part or wholly, expended upon the air. It differs from a *blown-out* shot only in the absence of the high temperature and pressure of the projected flame.

**887. Causes.**—The causes giving rise to the above are numerous, and may be summarized as follows:

(a) The shot may be too deeply laid.

1. The angle of a *gripped* shot may be too large; that is, the hole may be drilled at an angle so great that the charge will lie too deep.

2. The depth of a hole may locate the charge too much upon the *solid* (back of the *cutting* or *mining*).

3. The projecting bottoms and tops of the seam may arch the resistance in such a manner as not to allow the charge an opportunity to do its work.

(b) 1. The tamping (stemming) may be insufficient for the charge exploded or the sectional area of the hole.

2. The tamping may be of such an inflammable and gaseous nature as to become a dangerous factor in lengthening out the flame of the blast by the gases distilled from it under the flame of the blast.

(c) 1. The *solid*, in the region of the charge, may be creviced or fissured naturally, or by a former blast.

2. The coal may "seam out."

(d) 1. Too strong (fine-grained) a powder may be employed, which results in blowing the tamping and giving

vent to the flame and gases of the blast before the inertia of the mass has been overcome.

2. Too coarse a powder and too heavy a charge of it may result in a considerable amount of partly burned and burning powder being thrown out upon the air, to expend its energy in expansion instead of in mechanical work. A like result will always be produced by an *excessive* charge of any size powder.

3. A mixture of different grades of powder will nearly always result in a considerable portion of the charge being thrown upon the air, partly burned or burning. The mixing of a small amount of gunpowder with blasting powder, for the purpose of "making it stronger," is a pernicious act, and would justify the discharge of the man found guilty of so doing.

(e) A drill-hole of too large a diameter, as compared with the amount of the charge, will result, in the majority of cases, in the projection of the charge, because the large sectional area of the hole brings an undue pressure upon the tamping.

(f) 1. A succession of two or more blasts, fired in a limited working place, may produce an effect similar in every respect to that produced by a *windy shot*. It is caused by the firing of the carbonic oxide gas and the suspended dust of the first shot, by the flame of the second.

2. A like result obtains very often when a heavy blast is fired in too close proximity to accumulations of dust.

In general, if the hole is "gripped" too strongly, or the charge itself located too deeply upon the solid, a "blown-out" shot will result from the unyielding nature of the walls, and a flame of great intensity will be projected from the bore of the hole when the tamping or stemming has yielded.

If the charge is too heavy for the work to be accomplished, a "blown-out," but more properly called, a "*windy shot*," will result. The temperature of the flame will be normal in this case, but the danger arises from the projection and explosion of a considerable amount of the charge upon

the air after rupture has taken place. The energy of a portion of the charge is thus bestowed upon the air instead of being converted into mechanical work, by breaking down the coal.

**888. Flameless Explosives.**—From our previous study, we readily perceive the dangers incident to blasting in mine workings. So numerous are the conditions which render the use of explosives in a mine dangerous, that it has often been a matter of serious consideration whether the use of any form of explosives should be tolerated in mines known to be gaseous. It is recognized that the *flame* incident to the explosion is the dangerous factor, and many attempts have been made to so alter the composition of the explosive as to yield gaseous products which were not inflammable. This result has only been realized in part. Nevertheless, explosives have been produced in the combustion of which a very limited flame results; and the use of such explosives renders mining more safe. These are mostly formed by a mixture of nitrated compounds (ammonia nitrate and nitro-benzine, or nitro-naphthalene). For the most part, they are detonators, and are exploded by a fulminating cap.

---

#### DETONATING EXPLOSIVES.

**889.** The detonating explosives are divided into three general classes, viz.:

(a) Such as have *glycerine* for a base, as *nitroglycerine*, *dynamite*, *carbonite*, *stonite*, and *ardcerite*.

(b) Such as are formed from *cotton*, as *guncotton*, *tonite*, and *potentite*.

Gelignite and gelatine-dynamite (blasting gelatine) are formed by mixing nitroglycerine with guncotton, in varying proportions.

(c) Such as have ammonia nitrate for a base (called the Sprengel class, after their inventor), as *Roburite*, *Securite*, *Ammonite*, *Oxonite* (*Rack-a-rock*), *Panclastite*, *Bellite*, and *Hellhoffite*.

**890. Nitroglycerine** is a heavy, oily liquid, formed by the action of a mixture of strong nitric and sulphuric acids upon glycerine. It is a chemical compound, and as such differs from most other explosives. The dissociation of atoms takes place instantaneously throughout its mass, and thus affords one of the most powerful explosives known.

Its specific gravity is 1.6. It freezes at 40° F. Heated to 360° F., it either burns or explodes. One volume of nitroglycerine exploded yields 1,298 volumes of gas. Nobel places the temperature of the explosion at 3,270° F., and states that the *expanded* gases of the explosion will occupy 10,384 times the original volume, which will develop a ruptive pressure of 76.322 tons per square inch, under ordinary conditions.

Nitroglycerine, when frozen, will not explode by any ordinary cause; but an elevation of temperature makes its handling dangerous. It is readily exploded by a smart blow, when spread upon a flat surface; but a bottle of the liquid may be smashed to pieces, at times, without causing an explosion. When nitroglycerine has become sour and impure, spontaneous decomposition is developed, forming gas and oxalic acid, which often results in a disastrous explosion, especially when the liquid is contained in a tightly-stoppered vessel.

Nitroglycerine is rendered more safe for blasting purposes and for transportation, by its being employed in the form of *dynamite*.

**891. Dynamite.**—This explosive is nitroglycerine, absorbed by any porous substance. There are different grades of dynamite, differing by the varying amount of nitroglycerine absorbed. They are rated as follows, the percentages varying according to the different brands :

Grade No. 1, from 50 to 70 per cent. nitroglycerine.

Grade No. 2, from 33 to 50 per cent. nitroglycerine.

Grade No. 3, from 27 to 30 per cent. nitroglycerine.

Grade No. 4, from 20 to 25 per cent. nitroglycerine.

The principal brands in use are "Hercules," "Atlas," and

“Ætna.” The dynamite cartridges consist of strong paper shells, previously dipped in melted paraffine, and filled with the explosive. They are usually 8 inches long and of the following diameters and weights:

Diameter $\frac{7}{8}$ inch . . . . .	Weight about 4 ounces.
Diameter 1 inch . . . . .	Weight about 5 ounces.
Diameter $1\frac{1}{4}$ inches . . . . .	Weight about 8 ounces.
Diameter $1\frac{1}{2}$ inches . . . . .	Weight about 12 ounces.
Diameter $1\frac{3}{4}$ inches . . . . .	Weight about 15 ounces.
Diameter 2 inches . . . . .	Weight about $1\frac{1}{4}$ pounds.
Diameter 3 inches . . . . .	Weight about 3 pounds.
Diameter 4 inches . . . . .	Weight about 5 pounds.

The weight of any dynamite cartridge may be calculated by means of the following simple rule:

**Rule.**—*Multiply the square of the diameter of the cartridge by its length, all in inches, and take  $\frac{5}{8}$  of the product; the result will be the weight of the cartridge in ounces.*

Let  $W$  = weight of cartridge (ounces);  
 $d$  = diameter of cartridge (inches);  
 $l$  = length of cartridge (inches).

Then,  $W = \frac{5}{8} l d^2$ . (22.)

An average No. 2 grade of this explosive will yield an initial ruptive pressure of 24 tons per square inch.

Safe methods of using dynamite are explained further on, in the section on Shafts, Slopes, and Drifts.

Other forms of dynamite have been invented and brought forward from time to time. These mostly consist of nitroglycerine, in smaller quantities, absorbed in various waste products, as cork shavings, sawdust, etc. In the original dynamite, the absorbent was an infusorial earth found in northern Germany, which absorbed three times its own weight of nitroglycerine. The forms of dynamite referred to above are known as *carbonite*, *stonite*, and *ardcerite*.

**892. Guncotton** (nitro-cotton) is a product similar in all respects to nitroglycerine, being formed by the action of

a mixture of strong nitric and sulphuric acids upon ordinary cotton, or cellulose, wood-pulp, paper, or rags. In appearance, guncotton resembles ordinary cotton; 100 parts, by weight, of cotton should form 183 parts of guncotton; but, on account of more or less incomplete action, and a solution of a portion of the guncotton, before the whole mass has been converted, in practice 100 parts of cotton yield only from 160 to 178 parts of guncotton.

	Exploded in Free Air.	Detonated Under Pressure.
Carbonic oxide gas. . . . .	30 parts	40
Carbonic acid gas. . . . .	20 parts	25
Marsh-gas. . . . .	10 parts	Trace
Nitrogen dioxide . . . . .	9 parts	None
Nitrogen. . . . .	8 parts	15
Hydrogen. . . . .	None	20
Aqueous vapor . . . . .	23 parts	None

Guncotton is exploded by percussion. In some cases, it has been known to explode with violence when heated to 110° F., although other instances are recorded where the temperature has been raised to 200° F. without an explosion taking place. It has been known to be exploded by the heat of the sun's rays. It is liable to decompose, which often results in spontaneous combustion. Exploded, it yields a gaseous product consisting of 100 parts, as shown in the above table.

As will be readily seen, from its gaseous products, it is not adapted for use in mine workings. Its explosive force, as compared with an equal weight of gunpowder, is as 4.5 to 1.

**893.** *Tonite* and *potentite* are forms of guncotton to which nitrates of potassium, or barium have been added.

**894.** *Gelatine-dynamite*, or blasting-gelatine, and also *gelignite*, are mixtures of nitroglycerine and guncotton, on



the supposition that a more perfect combustion is thereby obtained. A honey-colored, gelatinous mass is obtained, which does not freeze as readily as nitroglycerine or dynamite, and withstands the action of water better. It is more liable to explosion from a sudden blow than is dynamite. Its gaseous products prevent its general use in mining.

**895. Sprengel Explosives.**—What may very properly be called the *Sprengel explosives*, after their inventor, are the highly nitrated compounds formed by varying mixtures of nitrate of ammonium,  $(NH_4)NO_3$ , which contains 60 per cent. of its weight of oxygen, with other nitrated compounds, as nitro-naphthalene, nitro-benzol, etc. The explosives belonging to this class are of recent invention and are not well known; but, on account of the property which they all possess, to a greater or less extent, of suppressing the *flame* of their explosion, they will eventually find an important application in mining (Art. 888). The most important and best known of these are *roburite*, *securite*, *ammonite*, *oxonite*, called also *rack-a-rock*, and *bellite*. The first three of these are alluded to as exceedingly safe and powerful explosives, by G. W. Wilkinson and other competent authorities.

**896. Comparison of Explosives.**—The value of an explosive lies in its being instantly convertible into gaseous products, having a high temperature and being incombustible. The explosive that embodies these qualifications to the highest degree is the strongest. However, except in very gaseous mines, high explosives are not used in coal-mining, because they shatter the coal and make too much small coal and slack. The less powerful and slower black powder is used, as it breaks down the coal in larger lumps.

(a) It is necessary, in order to secure the greatest rendering force in an explosive, that its transformation into the gaseous state should be *instantaneous* and *complete*.

(b) The higher the temperature developed in the explosion, the greater will be the expansive force of the gaseous products.

(c) The more incombustible the gaseous products, the less flame will be produced by the explosion, and the more security will attend its use in gaseous mines.

The following table will be of use to the mining student, in making comparisons between some of the more common explosives in use in mines.

TABLE 20.

Explosive.	Temperature of the Explosion (F.).	Products of Explosion.		Ruptive Pressure. (Pounds per Sq. In.)
		Combustible.	Incombustible.	
Blasting powder..	2,000° to 3,600°	42 per cent.	58 per cent.	12,400 to 20,500
Nitroglycerine ...	5,740°	0 per cent.	100 per cent.	152,640
Dynamite .....	5,280°	0 per cent.	100 per cent.	48,000
Blasting-gelatine..	5,880°	46 per cent.	54 per cent.	.....
Guncotton.....	4,800°	61 per cent.	39 per cent.	90,000 to 100,000
Tonite .....	4,800°	8 per cent.	92 per cent.	.....
Roburite.....	3,800°	0 per cent.	100 per cent.	.....
Ammonite .....	.....	0 per cent.	100 per cent.	.....
Securite.....	.....	0 per cent.	100 per cent.	.....
Carbonite .....	.....	41 per cent.	59 per cent.	.....

Table 21 gives the temperature of combustion of some of the more important gases relative to mining chemistry.

TABLE 21.

Gases.	Temperature of Combustion (F.).
Marsh-gas.....	1,220°
Ordinary illuminating gas ..	1,198°
Carbonic oxide gas.....	1,184°
Hydrogen.....	1,148°

**897. Character of Mine Explosions.**—Many conditions influence and determine the character of an explosion

of mine gases. The term *explosion*, in its present application, is broadened to include any type of rapid combustion of mine gases in the air-passages or workings, from a quiet burning, sweeping the roof of the passage and advancing at a moderate velocity, to a wild hurricane of fire, dust, and débris, propelled at an inconceivable speed by the expansive energies caused by the ignition of the gases in the air. The conditions that thus determine the character of an explosion of mine gases are, briefly, as follows:

(a) The **proportionate mixing of the gases** and their affinities for each other when excited by heat produces the violence of their dissociation and recombination in other forms as compounds.

For example, the explosive mixture may be air charged with marsh-gas, in such proportions as to develop its maximum violence; or, on the other hand, a large proportion of carbonic oxide gas may be produced as a result of a local explosion of marsh-gas, and this gaseous mixture may burn quietly along the roof of a passageway without exploding. Again, these conditions may suddenly change, and the slow burning at any moment develop explosive violence by contact with another body of gas.

(b) The **oxygen of the air** being the ever-ready means to dissociation, the abundance of its supply in the air of the workings determines largely the chemical activities.

(c) **Coal-dust**, suspended in the air of mine workings, acted upon by the flame of an explosion, distils **carbonic oxide gas**. This gas has the effect of lengthening the flame, which feeds upon it, and thereby propagates an otherwise local explosion.

(d) The physical surroundings of an explosion of mine gases, such as the size of the working places, and all the conditions which hinder the free expansion of the gases, affect the **pressure** and **temperature** of the explosion. These are important factors in determining the products of the explosion and the extent of the flame.

**898. Causes of Ignition.**—These are many. The ignition of an explosive mixture of gases requires some cause that will raise its temperature to the point of ignition. In the case of firedamp, however, this temperature must be maintained for a certain fraction of a second, or the gas fails to ignite. This is a very important point, as upon it depends the security of detonating explosives.

For example, the initial temperature of the explosion of dynamite is 5,280° F. (Table 20); but so rapid is the propagation of the combustion in the dynamite, that this temperature is only maintained for a time not exceeding  $\frac{1}{1000}$  of a second, when its heat is converted into mechanical work, the temperature falling simultaneously with the expansion far below the point of ignition for firedamp (1,220° F.), and thus failing to ignite this dangerous mixture. The interval of time necessary for the ignition of firedamp is probably due to the absorption of heat by the watery vapor formed by the dissociation, and which must be converted into steam at a high temperature before ignition of the gaseous products can take place.

In the case of the ignition of a body of gas (firedamp), the cause is usually the flame of a naked lamp, or a defective safety-lamp, or the flame incident to blasting.

In the case of an explosion in a *non-gaseous* mine, the gases which enter into the explosion are derived from the distillation of the coal-dust suspended in the air, and, in a measure, also from the fine coal pulverized by the crushing force of the blast. In this latter case, the cause of ignition is plainly the projected flame of a "*blown-out*" shot, which has a volume and intensity sufficient for the conversion of a large body of suspended dust into gas.

**899. Temperature of an Explosion.**—In any explosion whatever, whether it be a body of gas in the mine workings, or a charge of powder, or other explosive, in a drill-hole, the primary or initial temperature of the reaction is determined from the *heat units*, stored in the original constituents of the explosive mixture, and the *specific heats*

or *heat capacities* of the resulting products of the explosion. This *temperature of ignition* may be calculated from the principles of thermal chemistry, and is always a *fixed* temperature, as far as the explosive is concerned.

The *temperature of the explosion*, on the other hand, is determined or influenced by other causes, and is always, to a greater or less extent, lowered by external causes; as, for example, (a) loss of heat, by conduction, before the full development of the explosion; (b) loss of heat, by absorption due to expansion, before the full development of the explosion.

It will be readily seen that these losses are larger, the slower the progress of the combustion. Thus, in the case of a deflagrating charge, as of *black powder*, whose temperature of *ignition* is 3,632° F., the temperature of *explosion*, depending upon the strength of the resisting walls, is lowered to a practical 2,000° F. In the case of the quiet burning of a body of firedamp, diluted below the explosive point, or the burning of a trail of carbonic oxide gas, left in a passageway at times by the quick advance of an explosion, and fed later by fresh air from rooms or chambers, the *effective* temperature of the burning is often far below the actual temperature of ignition of these gases (firedamp 1,220°, carbonic oxide gas, 1,184°), on account of the absorption of the heat of ignition by the freely expanding gases.

**900. Coal-Dust.**—This discussion would not be complete without some special reference to the influence of this dangerous factor, present to a greater or less extent in many coal-mine explosions.

The presence of coal-dust suspended in the air of mine workings, and acted upon by a flame of sufficient volume and intensity, gives rise to *two* practical effects, viz.:

- (a) Elongation and propagation of the flame.
- (b) Widening of the explosive range of firedamp.

These effects have been described, (a), Art. **897** (c), and (b), Art. **860** (b).

The *facts* in regard to any kind of dust, and its influence upon the character of an explosion, are the following:

(a) The dust must be combustible, or it has, comparatively, no effect.

(b) The finer the dust and the more inflammable its nature, the quicker and fiercer will be its combustion.

(c) The free suspension of the dust in the air, and its complete combustion, are greatly assisted by a strong air current.

(d) The coal-dust (fine and larger particles) is heated to incandescence by the flame of the burning gases, distilling combustible gas, which adds to the flame, thereby transmitting the explosion through the airways.

(e) The incandescent carbon has the power to convert any carbonic acid gas ( $CO_2$ ) with which it comes in contact into combustible carbonic oxide gas ( $CO$ ).

The above facts are the results of practical experience, derived from actual observation of such occurrences, guided by an intelligent knowledge of the chemical possibilities, as demonstrated by experiment. The dust of anthracite coal is not susceptible of explosion under the prevailing conditions, being less friable and requiring a higher temperature to distil its gases.

**901. Reducing Liability to Explosion.**—The liability to accident by explosion can be reduced only by removing, as far as it is possible to do so, the causes and conditions which lead to such explosions. The incipient conditions of a mine explosion are, with rare exceptions, found in the following:

(a) A body of marsh-gas, collected in some cavity or recess of the roof or disused heading; or issuing suddenly from the working face, as a *feeder* or an *outburst*, and becoming transformed into a body of firedamp by its mixture with the air of the workings; and the presence and contact of the flame of a naked light, or a defective safety-lamp, or the projected flame of a blast, or, as sometimes occurs, the

flame of a safety-lamp blown through its gauze by the force of the current, or the force of a blast, to which it has been inadvertently exposed.

(b) The presence of a considerable quantity of fine coal, in the form of dust, in close proximity to a working face where blasting is performed; and the projection of the flame of a *blown-out shot* of such volume and intensity as to effect the raising of a cloud of the dust, and to convert the same into an incandescent volume generating combustible gas. This action has been proven, by the convincing results of experiments which leave no room to doubt, that the presence of marsh-gas, while it stimulates and strengthens the explosion, is by no means essential to it.

(c) The successive and quick firing of several shots, in a close working place, may precipitate an explosion, from the firing of considerable volumes of carbonic oxide gas, produced in the discharge of the first shots.

---

## SAFETY-LAMPS.

---

### DESCRIPTION OF LAMPS.

**902. General Description.**—A safety-lamp is a lamp of special construction. In appearance it very much resembles a small lantern, which it is. The flame is completely enclosed in wire gauze or in glass and wire-gauze casings, which prevent its contact with an outside body of gas. Its use serves two purposes; viz., *first*, protection in gaseous workings where an open light would cause serious results, by the ignition of the gas; and, *second*, to indicate to the miner the presence of gas.

**903. Principle of the Safety-Lamp.**—From our previous study of combustion (Art. 873), we have learned that the temperature of the burning gases must not fall below the point of ignition of those gases, or the flame will be extinguished. Whenever this temperature is not reached at the initial points of reaction, there can be no ignition, and hence no flame.

In safety-lamps, the isolation of the flame is secured through the cooling effect of the wire gauze surrounding it. The gauze permits the passage of air or gas, but flame is extinguished when it comes in contact with the cool gauze. (See Art. 904.)

**904. Effect of Cooling.**—Flame is the result of gases burning at a white heat. The temperature of ignition for each gas, in air, is a fixed point capable of calculation, and expresses the number of heat units evolved in the reaction, less the heat units absorbed and rendered latent by the products of the combustion. The proximity of any cooling surface whatever to a flame, has the effect of reducing the temperature of the reacting gases. The molecular vibrations of the cooler surface are so sluggish that the heat of the reaction in the flame is converted into *molecular work*, raising the temperature of the cool surface to a certain extent, but extinguishing the flame in its immediate proximity. This phenomenon may readily be observed by presenting a flame to a cool surface, when it will be seen that the flame does not touch the surface, but is separated by a thin layer of gas that does not burn, because it has been cooled below the point of ignition. This will continue as long as the surface remains cool. For the same reason, one may put a very cold hand, for a moment, into the flame of a fire without burning the hand or feeling the heat.

In the case of a flame impinging against a cool wire gauze, or other perforated surface, the conditions are very favorable for the cooling of the gases of the flame below the point of ignition, as they pass through the small openings. The gases are divided into minute streams or jets, by the meshes of the gauze, and cooled instantly, being thereby extinguished.

**905. Temperature of Flame.**—The cooling and extinguishing of a flame is greatly assisted by the air-currents pouring towards it, and diffusing among the gaseous molecules. This action of the air isolates, as it were, each burning hydrocarbon particle. Each separate particle is



thus surrounded by an envelope which renders more possible the cooling of the particle, because its temperature is somewhat below the temperature of ignition at the center. This has led to the rather indefinite and often misleading phrase, "*temperature of the flame.*" We can not rightly speak of the *temperature of flame* except in a general way, because it is not a definite quantity, but depends wholly upon conditions of which we have no gauge, and we find a different effective temperature in different parts of the same flame.

**906. Requirements of a Good Lamp.**—Safety-lamps, as previously stated, are used for two separate purposes, and this has given rise to two types of lamps, differing quite widely in their construction. They are:

- (a) Lamps for general mining use.
- (b) Lamps for testing for gas.

The requirements a good lamp must possess, for the purposes of general use in a mine, are the following:

- (a) Safety in strong currents.
- (b) Minimum liability to accident.
- (c) Maximum illuminating power.
- (d) Diffusion of light upwards.
- (e) Simplicity of construction, and security of fastenings or lock.

**907. Davy Lamp.**—Fig. 115 shows a perspective view of this lamp. Fig. 116 is a sectional view of the same lamp. The Davy lamp admits air freely through the lower part of the gauze, as shown by the arrows at *a a*; while the products of combustion pass out through the upper portion of the gauze cylinder *b b* and the gauze plate *c* at the top of the lamp. This free passage of the gas-charged air in and out of the lamp ensures a good cap, and has made the Davy lamp a favorite with fire bosses, notwithstanding the danger that is always present in the unbonneted Davy lamp of the flame of the lamp being communicated to the outside gas, either through flaming in the lamp or from exposure

to a current. The lamp is not safe when exposed to a current of a greater velocity than 6 feet per second. When gas is present in a thin stratum at the roof, its presence will



FIG. 115.

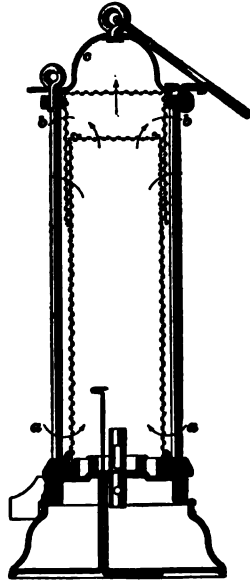

FIG. 116.

not be revealed by the Davy lamp. In the hands of a careful and experienced man, this lamp will detect the presence of gas in quantities as low as 3 per cent.

**908. Stephenson Lamp.**—This lamp consisted of a glass chimney surmounted by a perforated copper cap and surrounded by a perforated copper shield. The lamp gave a poor light, and was immediately supplanted by the Davy lamp with gauze covering.

**909. Geordy Lamp.**—This lamp, so called after George Stephenson, its inventor, was a combination of the glass chimney of the original Stephenson lamp and the gauze of the Davy lamp. It was regarded for a considerable time as a thoroughly reliable and safe lamp. It gave a better

light than the Davy lamp, and for a while came into quite extensive use. It was quite susceptible to gas, and made a good lamp for testing, because the gas-cap could be more easily distinguished through the glass than through the gauze, although the caps were not as high as in the Davy lamp. The supply, or feed, was more restricted, and entered the lamp below the flame and passed out through the gauze above the glass chimney.

**910. Clanny Lamp.**—This lamp was designed to secure greater protection for the flame, combined with a better light, than was provided in the Geordy lamp. A perspective view of the Clanny lamp is shown in Fig. 117, and a



FIG. 117.

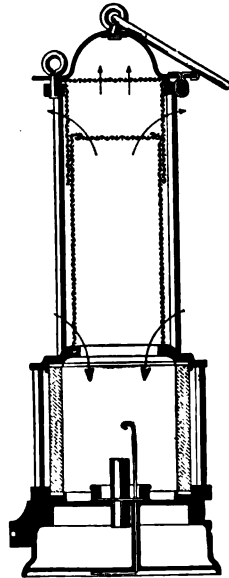

FIG. 118.

section of the same in Fig. 118. The air, instead of being admitted below the flame, as in the Geordy lamp, is admitted through the lower portion of the gauze cylinder, just above the glass, and descends, within the lamp, to the flame.

The lamp, while it may present some points of protection of the flame against strong currents, does not make a good lamp, either for testing or for general purposes of illumination. The glass is apt to become dimmed by the smoke of the flame, owing to the interference of the downward and upward currents above the flame. A considerable percentage of gas may be present in the air before its presence will be revealed by this lamp. The lamp loses its protective qualities whenever sufficient gas is present to produce flaming.

**911. Evan Thomas Lamp.**—This is an improvement upon the Clanny lamp, in two points; viz., the air drawn in at *a* (Fig. 119) is conducted downwards between the two



FIG. 119.



FIG. 120.

glass chimneys with which the lamp is provided, and enters the lamp below the flame. The upper gauze of the lamp is provided with a sheet-iron bonnet, which is a great protection in case of flaming or inner explosion. The downward

current of cool air serves, also, to keep the glasses cool, and increases their power to transmit light; a heated glass always impairs the transmission of light.

Fig. 120 shows another type of this lamp, designed for the use of fire bosses. The inner glass cylinder is replaced by a cylinder of gauze; in other respects the principle of the lamps is the same. At the time of the invention of this lamp, the study and designing of lamps, with respect to securing greater protection, received renewed attention, and resulted in bringing forward various devices having this end in view.

**912. Marsaut Lamp.**—The principal feature of this lamp, a perspective view of which is shown in Fig. 121 and a section of the same in Fig. 122, is the multiple-gauze



FIG. 121.

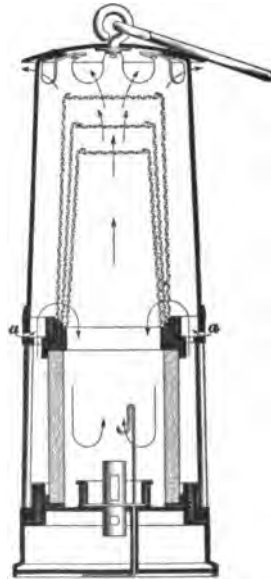

FIG. 122.

chimneys. The lamp shown in the figure (Fig. 122) has three of these gauze chimneys, one over the other, and an

outer bonnet of sheet iron. This lamp is adapted for use in strong currents. The air enters the lamp above the glass chimney; and much that has been said in reference to the Clanny lamp in this respect is applicable to the Marsaut.

**913. Mueseler Lamp.**—This lamp, of which Fig. 123 shows a perspective view and Fig. 124 a section, presents an



FIG. 123.

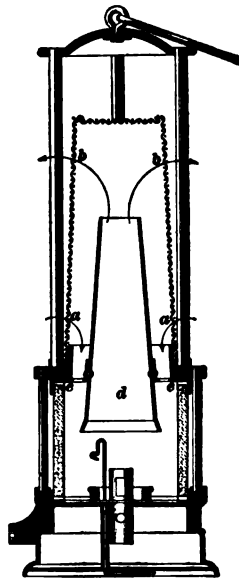

FIG. 124.

important departure. It is the first lamp introducing a feature calculated to increase its draft, and thereby improve its illuminating power. In this lamp is provided a central tube or chimney *d* of sheet iron, conical in shape, and held in position by a horizontal, perforated diaphragm of sheet iron *e e*, at the junction of the gauze and glass cylinders. The air enters the lamp through the gauze at *a a*, and, passing through the perforations of the diaphragm, is drawn down under the expanded mouth of the central chimney and in close proximity to the flame. The draft of this chimney increases to a considerable degree the

illuminating power of the lamp, while the central tube adds very largely also to the security of the lamp against currents and inner explosions, the latter seldom being communicated outside of the lamp. It is not a lamp adapted to the detection of gas, but it has been known to withstand a current of 100 feet per second.



FIG. 125.

**914. Howat's Deflector.**—This consists of an annular ring *A* (Fig. 125), so arranged as to deflect the entering current of air downwards upon the flame. It has been fitted to the Marsaut lamp, with a marked improvement in the illuminating power of that lamp.

**915. Ashworth-Hepplewhite-Gray Lamp.**—Among the lamps of special design for testing for gas,

that shown in Fig. 126 is perhaps the most convenient, and combines in one lamp many of the best features. The air, when the lamp is being used for testing, enters the tops of the four standards, as shown at *a a*, and, passing down the standards, enters the lamp below the flame, thereby producing the best conditions for yielding a good gas-cap. The glass chimney *ee* is made slightly conical, tapering towards the top; the same conical shape is, also, given to the gauze chimney *g*, above the glass. The gauze chimney is bonneted. The conical shape of the glass assists the

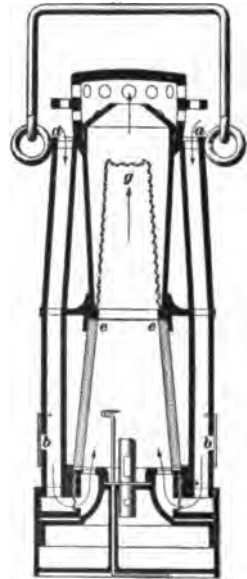

FIG. 126.

upward diffusion of the light, and makes the inspection of the roof easier; while the same shape in the gauze chimney renders the lamp more safe and secure against an inner explosion of gas being communicated outside of the lamp. The air being drawn into the lamp through the top of the standards, makes it possible with this lamp to detect a thin stratum of gas near the roof. When not in use for testing, the air may be admitted at the bottom of the standards, at *b b*, by moving a little shutter that closes them.

**916. Pieler Lamp.**—This lamp, shown in Fig. 127, is a gauze lamp, similar to a Davy lamp, but burns alcohol instead of oil, in order to render the observance of the gas-caps easier. In its safest form, the gauze is bonneted by a sheet-iron bonnet, the gas-caps being observed through a glass window. This window is very apt to become dimmed with smoke and moisture, and impair the observance of the caps. The lamp is provided with a shield *c*, surrounding the flame, and the latter is adjusted so that its tip does not extend above the top of the shield.



FIG. 127.

This lamp was designed by the inventor to yield a standard flame which would always present a certain height and volume, and yield flame-caps of a uniform height, for given percentages of gas. The following table was prepared by him to show the percentage of gas corresponding to different heights of flame-caps.

$\frac{1}{4}$  per cent. of gas yields a cap 1.25 inches high.

$\frac{1}{2}$  per cent. of gas yields a cap 2.00 inches high.

1 per cent. of gas yields a cap 3.50 inches high.

$1\frac{1}{4}$  per cent. of gas yields a cap 4.75 inches high.

$1\frac{3}{4}$  per cent. of gas  $\left\{ \begin{array}{l} \text{cap reaches the top of the lamp, and} \\ \text{beyond this percentage of gas the} \\ \text{lamp fills with flame.} \end{array} \right.$



The heights of these caps are measured from the top of the shield *c*. The lamp flames easily, in a mixture containing more than  $1\frac{1}{4}$  per cent. of gas, and is, therefore, a source of danger, and requires great care and caution in its use. Any variation in the strength of the alcohol varies the height of the flame. The flame is, therefore, not strictly a standard flame.

**917. The Illuminating Power of Safety-Lamps.—**

The amount of light given off by any safety-lamp is much less than that of the ordinary naked light used in mines. Table 22 gives the comparative illuminating power of some of the various lamps described. The light of a sperm candle is taken as 1, or unity.

**TABLE 22.**

Name of Lamp.	Illuminating Power of Lamp, with a Candle Taken as 1, or Unity.
Davy .....	0.16
Geordy.....	0.10
Clanny.....	0.20
Mueseler.....	0.35
Evan Thomas.....	0.45
Marsaut, 3 gauzes.....	0.45
Marsaut, 2 gauzes.....	0.55
Howat's Deflector.....	0.65
Ashworth-Hepplewhite-Gray.....	0.65 (about)

**918. Flame-Caps or Gas-Caps.—**By experiment, it has been determined that the presence of carbonic acid gas, even to the extent of 5 per cent., has no effect upon the flame-cap.

It has also been ascertained that the height of the flame-cap changes with the size and height of the flame itself, and also with the oil used to produce the flame.

**919. The Oil Used in Safety-Lamps.**—All the lamps described, with the exception of the improved Ashworth-Hepplewhite-Gray and the Pieler lamps, are constructed to burn either vegetable or seal oil. In the last two, light mineral oils are burned.

According to the English Mine Commission, the safest oils to use are vegetable oils, such as rape, made from rape-seed, and colza, made from cabbage-seed, and seal oil. None of these are explosive. Petroleum used alone is liable to explode, and should be avoided.

In point of brilliancy, the flame of a lamp burning seal oil is superior to one burning either rape or colza oil, and the wick is less liable to become charred.

By addition of one part of petroleum to two parts of rape or seed oil, the light is increased.

Many of the oils in common use in safety-lamps have a tendency to encrust the wick and thereby lower the flame. Sometimes petroleum or benzine has been added to the oil, which reduces this tendency, and yields a better flame for testing purposes. Alcohol yields a hotter and less luminous flame and a much higher cap. In some cases, a hydrogen flame has been used for testing purposes. The hydrogen is compressed into a small steel cylinder attached to the lamp, and is burned in the lamp at the mouth of a small tube. This apparatus gives a standard flame for testing, but it can not always be conveniently obtained.

**920. Locks for Safety-Lamps.**—All safety-lamps should be securely locked, and in such a manner as to preclude the possibility of being tampered with. Screw-pins are not an adequate protection.

The best lock, for security and cheapness, is the lead-plug lock, shown in Fig. 128.

On the right-hand side of the oil-vessel of the lamp a pin projects, with a hole in it. Around the bottom of the top part of the lamp there is a thin,



FIG. 128.

movable, metal ring *R*, and to this ring is fixed a hinged latch.

The ring is turned around, until the latch drops over the pin. A small plug of soft lead is put through the hole in the pin, to prevent the hinged latch from being lifted, and this lead plug is punched flat at both ends, to prevent it from being pulled out. The plugs are cast in a mold, at the colliery; and, as they are cut to pieces, in the lamp room, when the lamp is returned to be cleaned, they are collected and remelted, and the lead is used over and over again. To prevent tampering with the lead plug, it is punched up at both ends, with a punch containing a letter of the alphabet. These letters are interchangeable, and it is usual to use a new letter each day, so that the workmen can not counterfeit them.

Machines are used for locking these lamps, and other machines for cleaning them. Safety-lamps should be thoroughly cleansed at the close of every shift and put in readiness for another day.

---

### TESTING FOR FIREDAMP IN MINES.

**921. The Fire Boss.**—The duties devolving upon a fire boss are of a very serious nature. In his hands is often placed the safety of every man in the mine. A simple oversight upon his part may result in the most appalling catastrophe.

The safety-lamp, at the present time, is the only practical means at the disposal of this man for the detection of fire-damp. According to the good condition and sensitiveness of the lamp, and the experience of the man, his report of the condition of each working place and section of the mine under his charge is more or less accurate. That the fire boss should be a careful, painstaking, and conscientious man is readily seen upon a little reflection. Suppose, for example, a current of 50,000 cubic feet of air per minute is being furnished to a certain section of a gaseous mine. In this section, perhaps, the fire boss may detect a small percentage of gas in the current, say  $\frac{1}{4}$  of one per cent. The

total flow of gas is then  $\frac{1}{100}$  of 50,000 = 250 cubic feet per minute. If a door is left open upon the airway, or a fall occurs so as to reduce the current, say, to 3,000 cubic feet of air per minute, this gas will render the reduced current explosive in a very short time, and only prompt and decisive action on the part of the fire boss will avert a catastrophe.

**922. Testing by Lamp.**—The use of the lamp, for the purpose of testing for gas, depends upon the observing of the height of a pale, bluish tip, or cap, to the flame of the lamp. If the lamp flame is too bright, a small gas-cap can not be seen, as the eye will be blinded by the light of the flame.

For this reason the non-luminous, alcohol or hydrogen flames are better adapted for observing the gas-cap. The body of the flame should be screened from the eye while taking an observation. This is sometimes effected by holding the hand between the flame and the eye, or by interposing a metallic screen, as in the Pieler lamp.

The flame of the lamp is usually lowered to a small size when testing, and it is always best to adopt a uniform size of flame, to ensure uniform results. No quick movement must be made. In case of flaming in the lamp, coolness and presence of mind are necessary to remove the lamp carefully from the gaseous body. A quick movement will precipitate an explosion by the forcing of the inner flame through the hot gauze.

A good lamp for testing purposes will have a free admission of air, preferably below the flame. The background of the flame, or the gauze through which the flame is observed, should present no reflecting surfaces, as any reflection interferes seriously with the sensitiveness of the observation.

The lamp is, thus far, the most practical means at our disposal for gas-testing in mines. The percentages of gas in the air, determined by its use, are necessarily only approximately accurate; but the determination is made at

once at the point where the gas has accumulated, and the value of this approximate knowledge can not be disputed.

**923. Testing by Machines.**—Undoubtedly the Shaw Gas-Testing Machine, a view of which is shown in Fig. 129, is the most accurate, simple, and complete mechanical device for this purpose known. Its use, however, is restricted largely by its lack of portability. On account of this, it can not replace the method of testing for gas, at the working faces, by means of the safety-lamp.

The machine consists of two cylinders, or pump-barrels, *A* and *B*, constructed of such relative size, and so connected

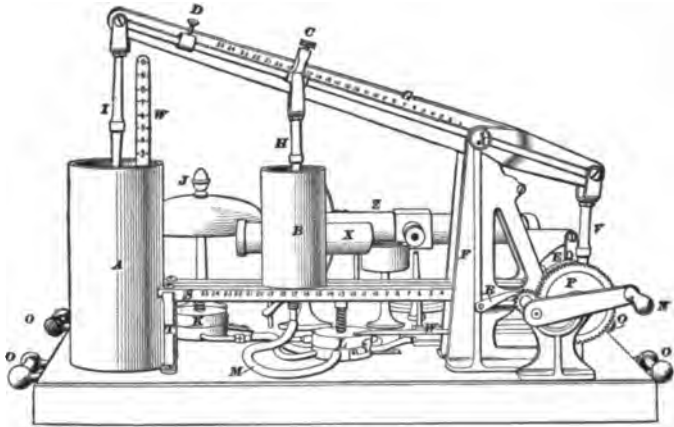

FIG. 129.

to a common lever *G*, as to pump relative quantities of gas and air into an ignition-chamber *Z*. One of the pump-cylinders *A* is stationary and pumps air, while the other cylinder *B* is so arranged as to be movable, and can be set to pump any proportionate amount of gas. Thus, it is easy to so arrange these two cylinders that a definite mixture of gas and air will be pumped into the ignition-chamber. The beam, or lever, is graduated to read the percentage of gas pumped.

The ignition-chamber *Z* is a cylinder having a loose piston. The mixture pumped into this chamber strikes first against

the piston, at the left-hand end of the cylinder, and, filling the cylinder, is expelled through an igniting nozzle at the opposite end. If the mixture is explosive, its ignition and explosion drives the piston forcibly against the gong *J*, at the end of the cylinder. The ignition is accomplished by a small gas-jet, or other flame burning at the discharge orifice of the chamber.



# MINE VENTILATION.

(PART 1.)

---

## INTRODUCTORY.

---

### GRAVITATION.

**924.** As a knowledge of gravitation and the laws of falling bodies is necessary in the study of mine ventilation, these subjects will be briefly treated before the principles governing the flow of air are discussed.

**925.** All bodies in the universe exert a certain attractive force on every other body, which tends to draw the bodies together. This attractive force is called **gravitation**.

If a body is held in the hand, a downward pull is felt, and if let go of will fall to the ground. This pull is commonly called *weight*, but it really is the attraction between the earth and the body.

**926.** **Force of gravity** is a term used to denote the attraction between the earth and bodies upon or near its surface. It always acts in a straight line between the center of the body and the center of the earth. The force of gravity varies at points on the earth's surface.

It is slightly less on the top of a high mountain than at the level of the sea. For this reason the weight of a body also varies. But if the weight of a body at any place be divided by the force of gravity at that place, the result is called the *mass* of the body.

**927.** The **mass of a body** is the measure of the actual amount of matter that it contains, and is *always the same*.

If the mass of the body is represented by  $m$ , its weight

$\frac{5}{8}$  6

For notice of the copyright, see page immediately following the title page.



by  $W$ , and the force of gravity at the place where the body is weighed by  $g$ , we have

$$\text{mass} = \frac{\text{weight of body}}{\text{force of gravity}}, \text{ or } m = \frac{W}{g}. \quad (23.)$$

### 928. Law of Gravitation :

*The force of attraction by which one body tends to draw another body towards it is directly proportional to its mass, and inversely proportional to the square of the distance between their centers.*

### 929. Laws of Weight :

*Bodies weigh most at the surface of the earth. Below the surface, the weight decreases as the distance to the center decreases.*

*Above the surface, the weight decreases as the square of the distance increases.*

ILLUSTRATION.—If the earth's radius is 4,000 miles, a body that weighs 100 pounds at the surface will weigh nothing at the center, since it is attracted in every direction with equal force. At 1,000 miles from the center it will weigh 25 pounds, since

$$4,000 : 1,000 = 100 : 25.$$

At 2,000 miles from the center it will weigh 50 pounds, since

$$4,000 : 2,000 = 100 : 50.$$

At 3,000 miles from the center it will weigh 75 pounds, and at the surface, or 4,000 miles from the center, it will weigh 100 pounds. If carried still higher, say 1,000 miles from the surface, or 5,000 miles from the center of the earth, it will weigh 64 pounds, since

$$5,000^2 : 4,000^2 = 100 : 64.$$

At 4,000 miles from the surface it will weigh 25 pounds, since

$$8,000^2 : 4,000^2 = 100 : 25.$$

**930. Formulas for Gravity Problems:**

Let  $W$  = weight of body at the surface;

$w$  = weight of a body at a given distance above or below the surface;

$d$  = distance between the center of the earth and the center of the body;

$R$  = radius of the earth = 4,000 miles.

Formula for weight when the body is below the surface,

$$w R = d W. \quad (24.)$$

Formula for weight when the body is above the surface,

$$w d^2 = W R^2. \quad (25.)$$

**EXAMPLE.**—How far below the surface of the earth will a 25-pound ball weigh 9 pounds?

**SOLUTION.**—Use formula 24,  $w R = d W$ .

Substituting the values of  $R$ ,  $W$ , and  $w$ , we have

$$9 \times 4,000 = d \times 25;$$

or 
$$d = \frac{9 \times 4,000}{25} = 1,440 \text{ miles from the center. Ans.}$$

**EXAMPLE.**—If a body weighs 700 pounds at the surface of the earth, at what distance above the earth's surface will it weigh 112 pounds?

**SOLUTION.**—Use formula 25,  $w d^2 = W R^2$ .

Substituting the values of  $R$ ,  $W$ , and  $w$ , we have

$$112 \times d^2 = 700 \times 4,000^2;$$

or 
$$d = \sqrt{\frac{700 \times 4,000^2}{112}} = 10,000 \text{ miles.}$$

Therefore,  $10,000 - 4,000 = 6,000$  miles above the earth's surface.

Ans.

**EXAMPLE.**—The top of Mt. Hercules was said to be 32,000 feet, say 6 miles, above the level of the sea. If a body weighs 1,000 pounds at sea-level, what would it weigh if carried to the top of the mountain?

**SOLUTION.**—  $w d^2 = W R^2$ ; or,  $w \times 4,006^2 = 1,000 \times 4,000^2$ ;

whence, 
$$w = \frac{4,000^2 \times 1,000}{4,006^2} = 997 \text{ pounds. Ans.}$$

**EXAMPLES FOR PRACTICE.**

1. How much would 1,000 tons of coal, weighed at the surface, weigh one mile below the surface? Ans. 1,999,500 lb.

2. How much would the coal in example 1 weigh one mile above the surface? Ans. 1,999,000 lb., nearly.

3. How far above the earth's surface would it be necessary to carry a body in order that it may weigh only half as much ?

Ans. 1,656.854 miles, nearly.

4. A man weighs 160 pounds at the surface; how much will he weigh 50 miles below the surface ?

Ans. 158 lb.

5. If a body weighs 100 pounds 400 miles above the earth's surface, how much will it weigh at the surface ?

Ans. 121 lb.

NOTE.—Use 4,000 miles as the radius of the earth.

### FALLING BODIES.

**931.** If a leaden ball and a piece of paper are dropped from the same height, the ball will strike the ground first.

This is not because the leaden ball is the heavier, but because the resistance of the air has a greater retarding effect upon the paper than upon the ball. If we placed this same leaden ball and a piece of paper in a glass tube, Fig. 130, from which all of the air has been exhausted, it would be found that, when the tube was inverted, both would drop to the bottom in exactly the same time. This experiment proves that it was only the resistance of the air that caused the ball to reach the ground first in the former experiment. This resistance of the air may be nearly equalized by making the two bodies of the same shape and size. For example, if a wooden and an iron ball, having equal diameters, were dropped from the same height, they would strike the ground at almost exactly the same instant, although the iron ball might be ten times as heavy



FIG. 130.

as the wooden ball.

Suppose there were several leaden balls, as shown in Fig. 131, at *a*; it is obvious that if they were dropped together, all would strike the ground at the same time. If the balls were melted together into one ball, as *b*, they would still fall together, and strike the ground in the same time as before.



FIG. 131.

Since a number of horses can not run a mile in less time than a single horse, so 100 pounds can fall no farther in a given time than 1 pound can.

**932. Acceleration** is the rate of increase of velocity. If a force acts upon a body free to move, then, according to the first law of motion, it will move forever with the same velocity unless acted upon by another force.

Suppose that, at the end of one second, the same force were to act again, the velocity at the end of the second second would be twice as great as at the end of the first second. If the same force were to act again, the velocity at the end of the third second would be three times that at the end of the first second. So, if a constant force acts upon a body free to move, the velocity of the body at the end of any time will be the velocity at the end of one second, multiplied by the number of seconds.

This constant force is called a **constant accelerating force**, or **constant retarding force**, according as the velocity is constantly *increased* or *decreased*.

If a body is dropped from a high tower, the velocity with which it approaches the ground will be constantly increased or accelerated; for the attraction of the earth, or force of gravity, is constant and acts upon the body as a constant accelerating force. It has been found by careful experiments that this force of gravity, or constant accelerating force on a freely falling body, is equivalent to giving the body a velocity of 32.16 feet in one second; it is always denoted by  $g$ . As was mentioned before,  $g$  varies at different points on the earth, being 32.0902 at the equator and 32.2549 at the poles. Its value for this latitude (about  $41^{\circ} 25'$  north) is very nearly 32.16, and this value should always be used in solving problems. It has also been found by experiment that a freely falling body starting from rest will have fallen 16.08 feet at the end of the first second; 64.32 feet at the end of the second second; 144.72 feet at the end of the third second; 257.28 feet at the end of the fourth second, etc., all of which are shown in the diagram, Fig. 132.

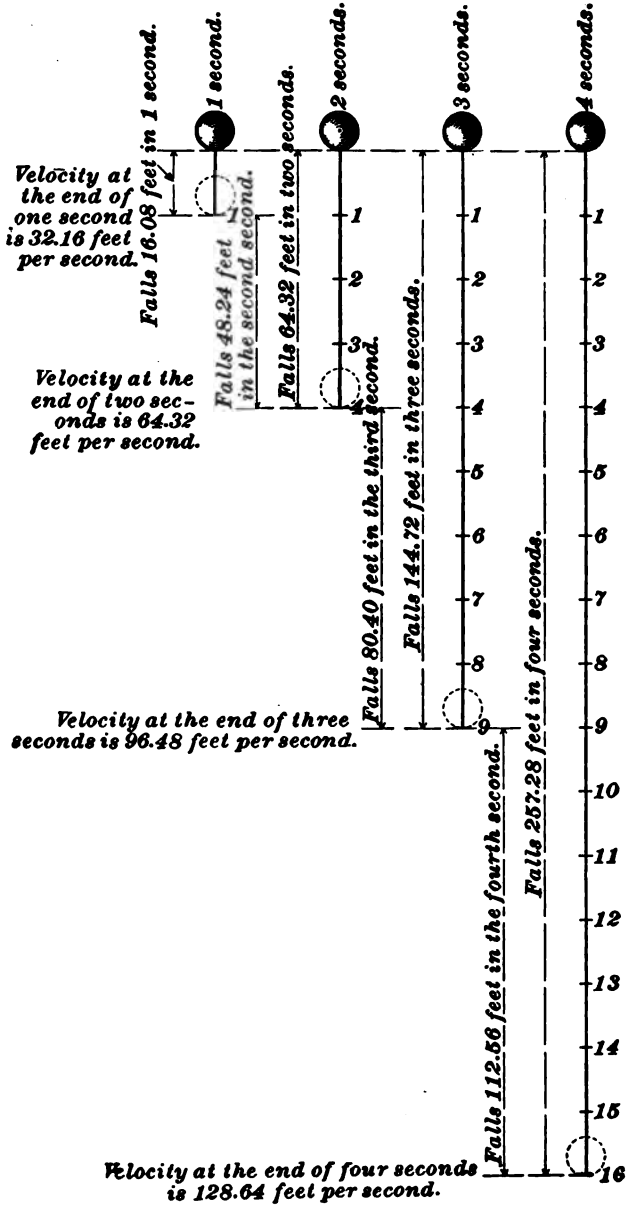

FIG. 132.

Since  $\frac{64.32}{16.08} = 4 = 2^2$ ;  $\frac{144.72}{16.08} = 9 = 3^2$ ;  $\frac{257.28}{16.08} = 16 = 4^2$ , and  $2^2$ ,  $3^2$ ,  $4^2$  are the squares of the number of seconds during which the body falls, it is easy to see that the space through which a body free to move will fall in a given time is equal to 16.08 multiplied by the square of the time in seconds.

Since  $16.08 = \frac{32.16}{2} = \frac{1}{2} g$ , the space  $= \frac{1}{2} g \times$  square of time in seconds.

### 933. Formulas for Falling Bodies:

Let  $g$  = force of gravity = constant accelerating force due to the attraction of the earth;

$t$  = number of seconds the body falls;

$v$  = velocity at the end of the time  $t$ ;

$h$  = distance that a body falls during the time  $t$ .

$$v = gt. \quad (26.)$$

*That is, the velocity acquired by a freely falling body at the end of  $t$  seconds equals 32.16, multiplied by the time in seconds.*

**EXAMPLE.**—What is the velocity of a body after it has fallen 4 seconds, assuming that the air offered no resistance?

**SOLUTION.**—Using formula 26,

$$v = gt = 32.16 \times 4 = 128.64 \text{ feet per second. Ans.}$$

$$t = \frac{v}{g}. \quad (27.)$$

*That is, the number of seconds during which a body must have fallen to acquire a given velocity equals the given velocity in feet per second, divided by 32.16.*

**EXAMPLE.**—A falling body has a velocity of 192.96 feet per second; how long had it been falling at that instant?

**SOLUTION.**—Using formula 27,

$$t = \frac{v}{g} = \frac{192.96}{32.16} = 6 \text{ seconds. Ans.}$$

$$h = \frac{v^2}{2g}. \quad (28.)$$

*That is, the height from which a body must fall to acquire a given velocity equals the square of the given velocity, divided by  $2 \times 32.16$ .*

EXAMPLE.—From what height must a stone be dropped to acquire a velocity of 24,000 feet per minute?

SOLUTION.— $24,000 \div 60 = 400$  feet per second. Using formula 28,

$$h = \frac{v^2}{2g} = \frac{400^2}{2 \times 32.16} = \frac{160,000}{64.32} = 2,487.56 \text{ feet. Ans.}$$

$$v = \sqrt{2gh}. \quad (29.)$$

*That is, the velocity that a body will acquire in falling through a given height equals the square root of the product of twice 32.16 and the given height.*

EXAMPLE.—A body falls from a height of 400 feet; what will be its velocity at the end of its fall?

SOLUTION.—Using formula 29,

$$v = \sqrt{2gh} = \sqrt{2 \times 32.16 \times 400} = 160.4 \text{ feet per second. Ans.}$$

$$h = \frac{1}{2}gt^2. \quad (30.)$$

*That is, the distance a body will fall in a given time equals 32.16  $\div$  2, multiplied by the square of the number of seconds.*

EXAMPLE.—How far will a body fall in 10 seconds?

SOLUTION.—Using formula 30,

$$h = \frac{1}{2}gt^2 = \frac{1}{2} \times 32.16 \times 10^2 = 1,608 \text{ feet. Ans.}$$

$$t = \sqrt{\frac{2h}{g}}. \quad (31.)$$

*That is, the time it will take a body to fall through a given height equals the square root of twice the height, divided by 32.16.*

EXAMPLE.—How long will it take a body to fall 4,116.48 feet?

SOLUTION.—Using formula 31,

$$t = \sqrt{\frac{2 \times 4,116.48}{32.16}} = 16 \text{ seconds. Ans.}$$

A body thrown vertically upwards starts with a certain velocity called the **initial velocity**. In this case gravity acts as a constant retarding force. The formulas given above will also apply in this case.

**EXAMPLE.**—If a cannon-ball is shot vertically upwards with an initial velocity of 2,000 feet per second, (a) how high will it go? (b) How long a time must elapse before it reaches the earth again?

**SOLUTION.**—(a) Using formula 26,

$$h = \frac{v^2}{2g} = \frac{2,000^2}{2 \times 32.16} = 62,189 \text{ feet, nearly,} = 11.778 \text{ miles. Ans.}$$

To find the time it takes to reach a height of 62,189 feet, use formula 27.

$$t = \frac{v}{g} = \frac{2,000}{32.16} = 62.19 \text{ seconds.}$$

Since it will take the same length of time to fall to the ground, the total time will be  $62.19 \times 2 = 124.38$  seconds = 2 minutes 4.38 seconds. Ans.

### THE NECESSITY OF VENTILATION.

**934. Ventilation** is the replacing of the foul air contained in an enclosed space by fresh air from the atmosphere.

To a person accustomed to working out of doors the necessity of ventilation is not apparent. He breathes, and the foul gas exhaled from his lungs dissipates into the ocean of atmosphere about him, leaving no trace behind, so rapidly is it diluted by the ever-moving air around him. When he descends into a mine, the case is widely different. Here, unless assisted by artificial means, the air-currents move very slowly or not at all. Poisonous gases from the workings must be diluted by fresh air; the men require a certain amount of fresh air to sustain life; the lamps require a certain amount in order that they may burn and give forth light; the horses or mules require still more; air or an air-current is required for other purposes. The result of all this is that unless a constant supply of fresh air is being circulated through the mine, it very soon becomes impossible for men or animals to live in it—much less work there.

The science of mine ventilation may be comprised under three general headings:

1. The quantity of air required.
2. The laws governing the flow of air through mines.
3. The means for inducing the flow of air through mines.



**THE QUANTITY OF AIR REQUIRED.**

**935.** The question as to what amount of air is necessary in mines does not admit of an exact answer. No two mines present the same conditions, and what is an ample provision of air in one mine is inadequate in another.

As each man requires a certain amount of pure air at every breath, it has been the rule in the past to select one man as the unit of calculation, and to allow so many cubic feet for every man employed underground. Some writers have made additional allowances for the mules and lamps.

Any estimate based on these lines is mere guesswork. The amount of air necessary for the support of life and the combustion of lights is insignificant in comparison with the other requirements.

A man requires a quantity of air which varies according to the exertion he is making, and this quantity, for a miner, may be estimated at 28 cubic feet per hour, or half a cubic foot per minute. A lamp consumes about the same quantity, and a mule about six times as much as a man.

A considerable quantity of air is required to render harmless the gas transpiring from the coal. If this gas were given off regularly, a correct estimate of the quantity of air required to dilute and render it harmless could be arrived at; but, owing to sudden outbursts, this can not be done.

A shallow mine is more likely to have had the gas drained off by the nearness of the seam to the surface, and is, therefore, not likely to require so much air for the removal of gas, in working, as a deep mine.

A change in the barometer has a decided influence upon the ventilation. A low barometer indicates a lighter weight of the air, and this, by reducing the pressure, assists in the freer admission of standing gas from the goaves and disused workings, and makes necessary an increased quantity of air to remove this gas. Heated air requires more fresh air to reduce the temperature and make the atmosphere of the mine healthy and comfortable for the workmen.

At the same time, it is necessary to remember that,

although the current should be sufficiently strong to enable it to be felt if the face is turned towards it, it must still not be so strong as to chill those who enter it while sweating.

**936.** The laws relating to the ventilation of coal-mines in the different States of the Union require, with two exceptions, a minimum of 100 cubic feet of air per man per minute. The Anthracite Mine Law of Pennsylvania fixes 200 cubic feet per man per minute as the minimum. The law of the State of Maryland fixes no minimum, but requires that the mine "shall be in a healthful condition for the men working therein." The English Mines Regulation Act of 1887 requires "sufficient to dilute and render harmless all noxious gases."

**937.** Instead of attempting to fix the quantity required at so much per man, it would be better to class the mines in each district into groups, having reference to the number of men employed, the area of the workings, the output, the nature of the coal, the depth of the workings from the surface and the general conditions regarding the amount of gas evolved, etc., and to make an average estimate of the volume required for the mines of each group.

In such a classification, the increase of the ventilation would be in accordance with the importance of the different requirements. These requirements may be summarized as follows :

The total quantity of air required should increase—

1. With the maximum number of men employed;
2. With the maximum number of mules in use;
3. With the maximum quantity of explosives used;
4. With the maximum daily output;
5. With the depth of the seam from the surface;
6. With the thickness of the seam;
7. With the extent of the live workings;
8. With the extent of the gob.

The volume of air to be allowed for these causes can be determined only after careful and exhaustive research, but,

if determined, it would ensure safety much more certainly than the minimum system at present in vogue.

In the largest and most gaseous mine in the anthracite region of Pennsylvania, the average quantity provided per man per minute ranges from 200 to 700 cubic feet.

---

## THE LAWS GOVERNING THE FLOW OF AIR.

---

### THE THEORETICAL VELOCITY OF AIR.

**938.** The **theoretical velocity** of air is the velocity at which the air enters the downcast shaft, and before it is subject to the resistance of friction due to the sides of the mine passages. It is a purely theoretical quantity and of little practical use. To produce a flow of air between the upcast and downcast shafts, the pressure, or weight, of the column of air in the downcast must be greater than the pressure, or weight, of the column of air in the upcast.

**939.** Suppose that Fig. 133 represents a section of a mine in which the downcast shaft  $AB$  and the upcast shaft  $DC$  have the same height.

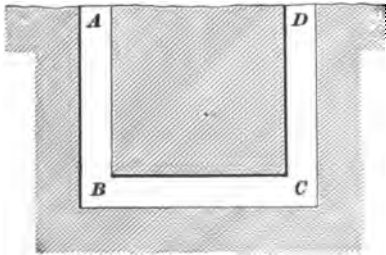

FIG. 133.

The air can be caused to flow from  $A$  to  $D$  by creating a difference of pressure or of weight in the columns of air in the two shafts, that in the shaft  $DC$  being less than that in the shaft  $AB$ .

This difference of pressure, or weight, of the air columns can be created in two ways: (1) By increasing the density, or pressure, of the air in the shaft  $AB$ . (2) By expanding the air, or decreasing the pressure, in the shaft  $DC$ . Each of these methods results in destroying the equilibrium, or equality of pressure, or weight, in the shafts.

Without entering here into a description of the methods for producing the difference of pressure, it may be stated that the ventilation is accomplished, according to the first of the above methods, by the use of a blowing-fan or by a waterfall, and, according to the second method, by means of a furnace, exhaust-fan, or steam-jet.

**940.** To find the theoretical velocity of air in a mine, due to the difference in the pressures in the upcast and downcast shafts, we have the following formula, in which

- $v$  = velocity of the air in feet per second;
- $F$  = the constant force represented by difference of pressure in pounds per square foot;
- $w$  = weight of a cubic foot of air;
- $g$  = acceleration due to gravity = 32.16 ft.

$$v = \sqrt{\frac{2gF}{w}}. \quad (32.)$$

**941. The Motive Column.**—That portion of the downcast column of air which represents the difference between the weights of the air columns in the downcast and the upcast shafts is called the **motive column**. The excess of weight in the air in the downcast over that in the upcast is what causes the flow of air up the upcast. Hence, if we subtract the pressure per square foot at the bottom of the upcast from the pressure per square foot at the bottom of the downcast, and divide the difference by the weight of a cubic foot

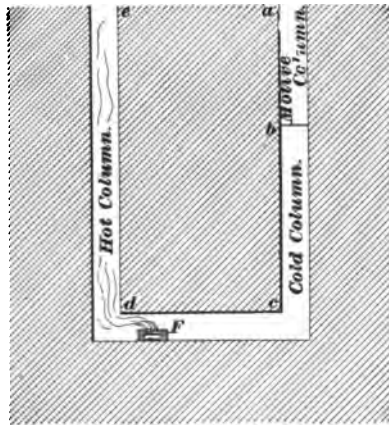

FIG. 134.

of air in the downcast, we have the length of the motive column, or the column whose weight overcomes the balance and causes the current to move up the upcast. For example, in

Fig. 134, the long hot column  $cd$  is equal in weight to the short cold column  $bc$ , and they balance each other, but the column  $ab$  of cold air is resting on  $bc$  and destroys the balance, and causes a current to flow; hence,  $ab$  is the motive column.

**942.** The length of the motive column may be found by means of one of the following formulas, in which

$W$  = the weight of a cubic foot of air in the downcast shaft;

$p$  = the pressure of the downcast shaft;

$p_1$  = the pressure in the upcast shaft;

$t_1$  = the average temperature of the air in the downcast shaft;

$t$  = the average temperature of the air in the upcast shaft;

$D$  = the depth of the upcast shaft in feet;

$M$  = the length of the motive column in feet;

$G$  = the water-gauge in inches. (See Art. 1058.)

$$\text{Then, } M = \frac{p - p_1}{W}. \quad (33.)$$

$$M = \frac{5.2 G}{W}. \quad (34.)$$

$$M = \frac{D(t - t_1)}{459 + t}. \quad (35.)$$

**EXAMPLE.**—If the temperature of the air in the downcast shaft is 40° F., and in the upcast shaft 120° F., what is the height of the motive column, the depth of the upcast shaft being 200 feet?

**SOLUTION.**—Applying formula 35,

$$M = \frac{D(t - t_1)}{(459 + t)} = \frac{200(120 - 40)}{(459 + 120)} = 27.63 \text{ feet.}$$

**PROOF.**—The proof of the accuracy of this conclusion may be found as follows: The weight of a cubic foot of air in the downcast shaft is .07968, and the weight of a cubic foot of air in the upcast shaft is .06867; then the entire weight of the upcast shaft column is  $.06867 \times 200 = 13.73400$  pounds, and the weight of the portion of the downcast column that balances the weight of the upcast column is  $200 \div 27.63 = 172.37$ , and  $172.37 \times .07968 = 13.734$  pounds.

In formula **35** it is assumed that the temperatures of the downcast and outer air are the same. There is no material error involved in this assumption, and the height of the motive column so obtained is practically correct, since any increase in temperature due to the depth is partly, if not wholly, neutralized by the moisture in the shaft absorbing heat from the air.

---

### PRESSURE AND RESISTANCES.

**943.** When the word "pressure" is used in mine ventilation, it means the force that produces a movement of the air through the workings, and is called the **ventilating pressure**. The velocities of air-currents depend upon differences in pressures, the greater the difference the greater the velocity of the current. It should, therefore, be remembered that it is not the gross pressure at the beginning of an air-current that produces its velocity, but rather the difference between the gross pressures at both ends, which is the *ventilating pressure*. A difference of pressure of one pound per square foot will produce a current of wind in the open air having a velocity of about 19 miles per hour.

**944.** The ventilating pressure may be expressed in pounds (in which case it is called the **total pressure**), in pounds per square foot, in inches of water-gauge, or in feet of motive column. Unless otherwise stated, it will be expressed in pounds per square foot. Should it be necessary to express it in inches of water-gauge, it may be easily converted into pounds per square foot by multiplying the number of inches of water-gauge by 5.2.

In order to avoid the long term "ventilating pressure," and also to make the language conform to other books pertaining to the subject of mine ventilation, the word *pressure* only will be used, except when it is thought best to use the full term.

The resistances met with in mines may be divided into three classes: First, the resistance due to friction; second, the resistance due to changing the direction of the current,

i. e., bends; third, the resistance due to contracting or enlarging the airway.

The most important of these resistances is that due to friction, and is the first that will be considered.

---

### THE THREE LAWS OF FRICTION.

**945.** As the result of many experiments, the truth of the three following laws, called the **three laws of friction**, has been firmly established.

**946. First Law.**—*When the velocity remains the same, the total pressure required to overcome friction varies directly as the extent of the rubbing surface.*

**947.** By **rubbing surface** is meant the entire area touched by the air in passing through the airway. The cross-section of the airway may be a square, a rectangle, a trapezoid, or a circle. If the cross-section is a square, the perimeter equals the length of one of the sides of the cross-section multiplied by 4; if a rectangle or trapezoid, the perimeter equals the sum of all the sides, and if a circle, the perimeter equals the diameter multiplied by 3.1416. Having found the perimeter, the rubbing surface may be found by multiplying the perimeter by the length of the airway.

**948.** The first law states that if the rubbing surface be increased, the pressure must be increased in the same proportion in order to pass the air with the same velocity. In other words, if the rubbing surface be increased  $1\frac{1}{2}$ , 2, 3, 4, etc., times, the pressure must also be increased  $1\frac{1}{2}$ , 2, 3, 4, etc., times in order to pass the same quantity of air.

In applying this law, it does not matter whether the pressure per square foot or the total pressure is considered, if in the first case the sectional area remains the same.

**EXAMPLE.**—Suppose that a certain airway passes 10,000 cubic feet of air per minute; what must be the increase in pressure in order to pass the same amount through an airway whose cross-section has the same area, but whose rubbing surface is 1.6 times as great?

**SOLUTION.**—Since the rubbing surface is increased 1.6 times, while the other factors (velocity, quantity, sectional area, etc.) remain the same, it follows that, according to the first law of friction, the pressure must also be increased 1.6 times. Ans.

**949.** The form of the cross-section of the airway exerts a considerable influence on the amount of rubbing surface, as the following examples will show :

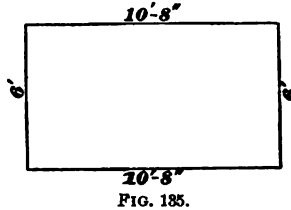

FIG. 135.

**EXAMPLE 1.**—Find (a) the rubbing surface and (b) the area of the cross-section of an airway 1,000 feet long having a rectangular cross-section, whose sides are 10 feet 8 inches long by 6 feet high. (See Fig. 135.)

**SOLUTION.**—(a) The rubbing surface equals the perimeter multiplied by the length; or, since 10 ft. 8 in. =  $10\frac{2}{3}$  ft.,  $(10\frac{2}{3} + 6 + 10\frac{2}{3} + 6) \times 1,000 = 33\frac{1}{3} \times 1,000 = 33,333\frac{1}{3}$  sq. ft. Ans.

(b) Area =  $10\frac{2}{3} \times 6 = 64$  sq. ft. Ans.

**EXAMPLE 2.**—Suppose that in the preceding example the rectangular section had been 16 feet wide and 4 feet high, what would have been the rubbing surface and area ?

**SOLUTION.**—The rubbing surface =  $(16 + 4 + 16 + 4) \times 1,000 = 40 \times 1,000 = 40,000$  sq. ft., and the area =  $16 \times 4 = 64$  sq. ft. Ans.

In this example the cross-sectional area is the same as in example 1, while the rubbing surface is  $\frac{1}{3}$  greater. Had the sides been 32 feet and 2 feet, the sectional area would have been 64 square feet, as above, but the rubbing surface would have been  $(32 + 2 + 32 + 2) \times 1,000 = 68,000$  square feet, or 2.07 times as much as in example 1. Hence, to pass the same quantity of air, the pressure would require to be increased 1.07 times.

**950.** It is easy to see that the more oblong the rectangle is the more rubbing surface there is for the same sectional area, and it is evident that the perimeter of a square section is less than that of a rectangular section having the same area. Thus, the perimeter of the square, Fig. 136, is but 32 feet, while that of the rectangle in Fig. 135 is  $33\frac{1}{3}$  feet, and that of the rectangle in example 2 is 40 feet. If



Fig. 136 represents a section of an airway 1,000 feet long,

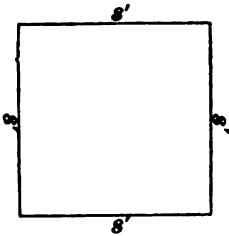

FIG. 136.

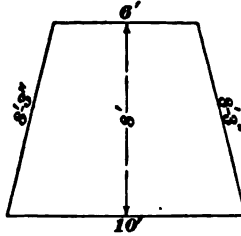

FIG. 137.

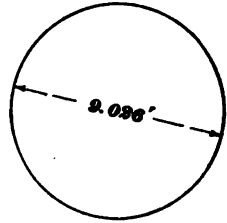

FIG. 138.

the rubbing surface is  $32 \times 1,000 = 32,000$  square feet.

**EXAMPLE 3.**—Suppose an airway to have a trapezoidal cross-section like that shown in Fig. 137, and to be 1,000 feet long; what is the rubbing surface and sectional area?

**SOLUTION.**—The rubbing surface (since 8 ft. 3 in. =  $8\frac{3}{4}$  ft.) equals  $(10 + 8\frac{3}{4} + 6 + 8\frac{3}{4}) \times 1,000 = 32,500$  sq. ft., and sectional area =  $\frac{6 + 10}{2} \times 8 = 64$  sq. ft. Ans.

**EXAMPLE 4.**—A circular airway is 9.026 feet in diameter and 1,000 feet long; what is its rubbing surface and sectional area?

**SOLUTION.**—The rubbing surface equals 3.1416 times the diameter multiplied by the length =  $3.1416 \times 9.026 \times 1,000 = 28.36 \times 1,000 = 28,360$  sq. ft., and the sectional area =  $9.026^2 \times .7854 = 64$  sq. ft.

It will be noticed that in all of the above examples the area of the cross-section is 64 square feet, while the rubbing surface varies from 28,360 to 68,000 square feet.

The results obtained above are all combined in the following table, and show at a glance the effect produced by varying the forms of the cross-section, the sectional area and the length of the airway being the same in all.

**951.** Table 23 shows that for a given sectional area the circular airway has the least rubbing surface, and that the square airway comes next, while, with rectangular airways, that which most nearly approaches the square form has the least rubbing surface. Hence, for economy in ventilation, circular airways are best; but, since they are seldom practicable, owing to other considerations, square airways should be used whenever it is possible to do so. If rectan-

gular or trapezoidal airways are absolutely necessary, they should, in so far as it is practicable, approach the square form.

**TABLE 23.**

Form of Section.	Dimensions of Section.	Length in Feet.	Perimeter in Feet.	Rubbing Surface in Square Feet.	Sectional Area in Square Feet.
Circular	9.026' diam.	1,000	28.36	28,360	64
Square	8' × 8'	1,000	32	32,000	64
Trapezoidal	(10' and 6') × 8½'	1,000	32½	32,500	64
Rectangular	10' 8' × 6'	1,000	33½	33,333	64
Rectangular	16' × 4'	1,000	40	40,000	64
Rectangular	32' × 2'	1,000	68	68,000	64

It is evident that increasing the length of the airway will also increase the rubbing surface. Hence, if two airways have the same perimeter and area, but different lengths, and the air is transmitted with the same velocity in each, the pressures will be in direct proportion to the lengths.

**EXAMPLE.**—Two airways are each 6 feet high and 9 feet wide; consequently their areas of section and perimeters are equal. The length of one of these airways is 1,800 feet, and the pressure indicated by the water-gauge is 1.72 inches; the length of the other airway is 2,700 feet. If the velocity is the same in both these airways, what should be the height of the water-gauge for the airway 2,700 feet in length?

**SOLUTION.**—Since the areas, perimeters, and velocities are the same, the heights of the water-gauges will be directly as the lengths of the airways, or  $1.72 : x :: 1,800 : 2,700$ ; whence,  $x = 2.58$  in. Ans.

**952. Second Law.**—*When the velocities and rubbing surfaces remain the same, the pressures required to force air through the passages of a mine increase and decrease inversely as the sectional areas of the passages increase or decrease.*

**953.** The second law states that if the velocity remains the same and the rubbing surfaces are equal, the pressure per square foot will increase as the sectional area decreases;

or, the pressure per square foot will decrease as the sectional area increases; that is, if the sectional area be reduced to  $\frac{1}{2}$ ,  $\frac{1}{4}$ ,  $\frac{1}{8}$ ,  $\frac{1}{16}$ , etc., of the original sectional area, the pressure per square foot must be increased, 2, 4, 6, 10, etc., times, respectively, to pass the air with the same velocity, the rubbing surface being the same in both cases. Or, if the sectional area be increased 2, 4, 6, 10, etc., times the original sectional area, the pressure per square foot may be, respectively, reduced to  $\frac{1}{2}$ ,  $\frac{1}{4}$ ,  $\frac{1}{8}$ ,  $\frac{1}{16}$ , etc., of the original pressure per square foot required to pass the air with the same velocity, the rubbing surface being the same in both cases.

**EXAMPLE.**—Suppose that the pressure per square foot required to pass air at a given velocity is .02 inch per square foot in a square airway 8 feet high and 8 feet wide. What pressure per square foot will be required to pass air at the same velocity through a circular airway whose perimeter is the same as that of the square one, namely, 32 feet, and whose length is the same as that of the square one?

**SOLUTION.**—According to the second law of mine friction, when the velocities are the same, the pressures vary inversely as the sectional areas of the airways. If the perimeter be divided by 3.1416, the quotient will be the diameter of the section of the circular airway; and the square of this diameter multiplied by .7854 is the area of the cross-section of the circular airway in square feet; hence,

$$\text{area} = \left( \frac{32}{3.1416} \right)^2 \times .7854 = 81.49 \text{ square feet.}$$

Then the pressure required is found by the proportion  $81.49 : 64 :: .02 : x$ ; or,  $x = .0157$  inch of water-gauge. Ans.

**954.** The second law only applies to *pressure per square foot*, for the total pressure remains the same, as it should; since, when the rubbing surface and velocity remain the same, the total resistance (= total pressure) must also remain the same, no matter what the sectional area may be. Thus, in the above example, the total pressure for the square airway is  $64 \times .02 = 1.28$  lb., and for the circular airway,  $81.49 \times .0157 = 1.28$  lb.

**EXAMPLE.**—(a) An  $8' \times 10'$  rectangular airway is 5,000 feet long; what must be the length of a similar airway,  $6' \times 8'$ , having the same rubbing surface? (b) If a pressure of .5 pound per square foot is required to pass the air through the  $8' \times 10'$  airway with a certain velocity, what pressure per square foot is required to pass the air through the  $6' \times 8'$  airway with the same velocity?

SOLUTION.—(a) The rubbing surface of the 8' × 10' airway is  $(8 + 10 + 8 + 10) \times 5,000 = 180,000$  sq. ft. The perimeter of the 6' × 8' airway is  $6 + 8 + 6 + 8 = 28$  ft. Consequently, the length of the 6' × 8' airway is  $180,000 \div 28 = 6,428\frac{1}{2}$  ft. Ans.

(b) Since, according to the second law of friction, the pressures per square foot vary inversely as the sectional areas, when the rubbing surfaces and velocities remain the same, and the sectional areas are  $8 \times 10 = 80$  sq. ft., and  $6 \times 8 = 48$  sq. ft.,  $80 : 48 :: x : .5$ ; or,  $x = .8\frac{1}{2}$  lb. per square foot. Ans.

Here again the total pressures are the same, since  $80 \times .5 = 40$  lb., and  $48 \times .8\frac{1}{2} = 40$  lb.

**955. Third Law.**—*The pressure required to overcome friction in an airway varies as the squares of the velocities when the rubbing surface and the areas of section are the same; and the pressures required to overcome friction vary as the squares of the velocities multiplied by the rubbing surfaces per square foot of section in all airways.*

**956.** If the velocity be increased  $1\frac{1}{2}$ , 2, 3, 5, etc., times, the rubbing surface remaining the same, the pressure must be increased  $(1\frac{1}{2})^2$ ,  $2^2$ ,  $3^2$ ,  $5^2$ , etc., or  $2\frac{1}{4}$ , 4, 9, 25, etc., times, respectively; and if the velocity be reduced  $1\frac{1}{2}$ , 2, 3, 5, etc., times, the rubbing surface remaining the same, the pressure must be reduced  $(1\frac{1}{2})^2$ ,  $2^2$ ,  $3^2$ ,  $5^2$ , etc., or  $2\frac{1}{4}$ , 4, 9, 25, etc., times, respectively.

If the sectional area and rubbing surface both remain the same, the pressure per square foot will also vary directly as the square of the velocity.

EXAMPLE.—Suppose that in the last example the velocity was 400 feet per minute, and that it was desired to increase it to 450 feet per minute, what would be the total pressure required?

SOLUTION.—Since the pressures vary directly as the squares of the velocities,  $400^2 : 450^2 :: 40 : x$ ; or,  $x = 50\frac{1}{2}$  lb. Ans.

EXAMPLE.—In the above example, what would be the pressure per square foot, were the velocity increased from 400 to 450 feet per minute in the 6' × 8' airway?

SOLUTION.—The pressure per square foot was found to be  $.8\frac{1}{2}$  pound; hence, according to the third law, since the sectional area and rubbing surface remain the same,  $400^2 : 450^2 :: 8\frac{1}{2} : x$ ; or  $x = 1.055$  lb. per square foot. Ans.

### THE COEFFICIENT OF FRICTION.

**957.** By means of the three laws of friction, and by the aid of other laws which can be deduced from them, and which will be given later, it is possible, when all of the data for one airway and a part of the data for another airway are known, to calculate the remaining data for the second airway; or, if all the data for an airway are known, to calculate the effect produced by varying the pressure, velocity, etc. But in order to calculate the pressure required to force the air (overcome the resistances) through a given airway, to calculate the pressure required to pass a certain quantity per minute through a given airway, and to calculate the horsepower, etc., it is necessary to know the *coefficient of friction*.

**958.** *The coefficient of friction is that amount of the total ventilating pressure which is required to overcome the resistance offered by one square foot of rubbing surface when the velocity is 1 foot per minute.*

**959.** For example, this may be further explained by stating that the coefficient of friction is equivalent to the pressure required to overcome the friction in an airway one-quarter of a foot long, 1 foot square in section, and through which the air is passing with a velocity of 1 foot per minute.

Since the total pressure may be expressed in pounds, or as so many feet of motive column, having a cross-section equal to the sectional area of the airway, the coefficient of friction may also be expressed as a fraction of a pound or a factor of the motive column in feet. In the various works treating on mine ventilation, the coefficient is usually expressed in pounds, and will be so expressed throughout this discussion.

The coefficient of friction then becomes a unit which, multiplied by the rubbing surface in square feet (according to the first law), and again multiplied by the square of the velocity in feet per minute (according to the third law), will give the total ventilating pressure in pounds.

**960.** The coefficient of friction varies somewhat for different mines, according to the degree of smoothness of the rubbing surface, and probably to a slight extent on account of the character of the material forming the sides of the airway. Different experimenters have obtained values which show considerable variation in their results; but the value most commonly used is that determined by J. J. Atkinson, and is the one which will be used in this discussion. This unit is known to be too high, but since every change in direction, owing to bends, and every reduction or enlargement of the passageway, etc., entails extra losses which are very difficult to calculate, it will be more convenient to use Atkinson's coefficient and disregard the extra losses. By so doing, the entire air-course is treated as if it were a straight airway, and the calculations are greatly simplified. The value of Atkinson's coefficient of friction is .000000217 pound. In other words, the pressure required to overcome the resistance offered by 1 square foot of rubbing surface when the velocity is 1 foot per minute, is that part of a pound represented by 217 divided by 1 followed by 10 ciphers, or .000000217, expressed decimally.

**961. EXAMPLE.**—(a) What is the total pressure required to overcome the frictional resistances of a 6' × 8' airway, 12,750 feet long, if the velocity is 480 feet per minute? (b) What is the pressure per square foot? (c) What should the water-gauge read?

**SOLUTION.**—(a) According to the foregoing statements, the total pressure is equal to the continued product of the coefficient of friction, the rubbing surface, and the square of the velocity; hence, since the rubbing surface =  $28 \times 12,750 = 357,000$  sq. ft., total pressure =  $.000000217 \times 357,000 \times 480^2 = 1,784.89$  lb. Ans.

(b) The pressure per square foot equals the total pressure divided by the sectional area =  $\frac{1,784.89}{8 \times 6} = 37.18$  lb. per square foot. Ans.

(c) Since 1 inch of water-gauge represents a pressure of 5.2 pounds per square foot, 37.18 pounds represent  $\frac{37.18}{5.2} = 7.15$  in. Ans.

**962.** To express the foregoing by means of formulas, let

$P$  = total ventilating pressure in pounds;

$p$  = ventilating pressure in pounds per square foot;

$a$  = sectional area of airway in square feet;  
 $k$  = coefficient of friction = .0000000217;  
 $s$  = total rubbing surface in square feet;  
 $v$  = velocity of air in airway in feet per minute;  
 $o$  = perimeter of airway in feet;  
 $l$  = length of airway in feet;  
 $W$  = water-gauge in inches.

Throughout this subject the letters as printed above will always represent the same quantities.

$$P = p a. \quad (36.)$$

*That is, the total pressure equals the pressure per square foot multiplied by the sectional area of the airway.*

EXAMPLE.—If the sectional area of the airway is 56 square feet, and the pressure per square foot is 8.46 pounds, what is the total pressure?

SOLUTION.—Applying formula 36,

$$P = p a = 8.46 \times 56 = 473.76 \text{ lb. Ans.}$$

$$P = k s v^2. \quad (37.)$$

*That is, the total pressure equals the continued product of the coefficient of friction, the rubbing surface, and the square of the velocity.*

EXAMPLE.—An airway 6'  $\times$  6' and 5,000 feet long passes air with a velocity of 340 feet per minute; what is the total ventilating pressure?

SOLUTION.—Applying formula 37,  $s = 6 \times 4 \times 5,000 = 120,000$  sq. ft., and  $v = 340$ . Hence,  $P = k s v^2 = .0000000217 \times 120,000 \times 340^2 = 801$  lb., nearly. Ans.

$$p = \frac{k s v^2}{a}. \quad (38.)$$

*That is, the pressure per square foot equals the continued product of the coefficient of friction, the rubbing surface, and the square of the velocity, divided by the sectional area of the airway.*

EXAMPLE.—What is (a) the pressure per square foot in the last example? (b) the water-gauge?

SOLUTION.—(a) Substituting in formula 38,  $a = 6 \times 6 = 36$  sq. ft., and

$$p = \frac{.0000000217 \times 120,000 \times 340^2}{36} = 8.36 \text{ lb. Ans.}$$

(b) Since  $p = 5.2 W$ ,  $W = \frac{p}{5.2} = \frac{8.36}{5.2} = 1.61$  in., nearly. Ans.

$$s = \frac{P}{k v^2} = \frac{p a}{k v^2}. \quad (39.)$$

*That is, the rubbing surface equals the total pressure divided by the coefficient of friction multiplied by the square of the velocity; or, it equals the pressure per square foot multiplied by the sectional area divided by the product of the coefficient of friction and the square of the velocity.*

EXAMPLE.—A gangway is 8'  $\times$  8'; if the water-gauge shows  $\frac{1}{4}$  inch and the velocity of the air is 280 feet per minute, what is the rubbing surface?

SOLUTION.—The pressure per square foot is  $p = 5.2 W = 5.2 \times \frac{1}{4} = 8.9$  lb. per square foot; the sectional area is  $8 \times 8 = 64$  sq. ft.

Hence, substituting in formula 39,

$$s = \frac{p a}{k v^2}; \text{ or, } s = \frac{8.9 \times 64}{.0000000217 \times 280^2} = 146,713 \text{ sq. ft. Ans.}$$

$$v = \sqrt{\frac{p a}{k s}}. \quad (40.)$$

*That is, the velocity in feet per minute equals the square root of the pressure in pounds per square foot multiplied by the sectional area in square feet, divided by the product of the coefficient of friction and the rubbing surface in square feet.*

EXAMPLE.—In the last example suppose that the rubbing surface was known to be 146,713 square feet, and it was desired to find the velocity. Show how you would find it.

SOLUTION.—Substituting the different values in formula 40,

$$v = \sqrt{\frac{p a}{k s}} = \sqrt{\frac{8.9 \times 64}{.0000000217 \times 146,713}} = 280 \text{ ft. per min. Ans.}$$

When the total rubbing surface and the perimeter are known, the length of the airway may be found by means of the formula

$$l = \frac{s}{o}. \quad (41.)$$

*That is, the length of the airway is equal to the rubbing surface divided by the perimeter.*



**EXAMPLE.**—The perimeter of an airway is 82 feet, and the rubbing surface is 146,718 feet; what is the length of the airway?

**SOLUTION.**—Applying formula 41,

$$l = \frac{s}{o} = \frac{146,718}{82} = 4,585 \text{ ft. Ans.}$$

As before stated, the rubbing surface equals the product of the length and the perimeter; or,

$$s = lo. \quad (42.)$$

### THE QUANTITY OF AIR DISCHARGED.

**963.** Since a certain quantity of air is required to pass along the airway in order to secure the proper amount of ventilation, it is necessary to know how much air can be passed with a given velocity; or, knowing the quantity required, it is necessary to calculate the velocity, and from that to determine the pressure. If the velocity and sectional area are known, the quantity may be determined by the following formula, in which  $q$  = the quantity in cubic feet per minute:

$$q = a v. \quad (43.)$$

*That is, the quantity of air discharged in cubic feet per minute through a given airway is equal to the area of the section in square feet multiplied by the velocity in feet per minute.*

**964.** A little consideration will show that formula 43 must be true; for, suppose that the sectional area is 1 square foot and the velocity is 1 foot per minute; then it is perfectly evident that the quantity discharged in 1 minute is 1 cubic foot. If the velocity be increased 2, 3, 4, etc., times, the number of cubic feet discharged will also be, respectively, 2, 3, 4, etc., times the original quantity; that is, the velocity will be 2, 3, 4, etc., feet per minute, and the quantity 2, 3, 4, etc., cubic feet per minute. Likewise, if the velocity remains at 1 cubic foot per minute, but with the area increased 2, 3, 4, etc., times, the quantity will be increased to 2, 3, 4, etc., cubic feet per minute. Consequently, if the area and velocity are both changed, the change in quantity must be the product of the two; that is, if the area be increased

from 1 square foot to, say, 26 square feet, and the velocity increased from 1 foot per minute to 1,000 feet per minute, the quantity will be increased from 1 cubic foot to  $26 \times 1,000 = 26,000$  cubic feet per minute.

**EXAMPLE.**—A circular airway has a diameter of 9.026 feet, and the velocity of the air is 330 feet per minute; what is the quantity passing in cubic feet per minute?

**SOLUTION.**—Applying formula 43,  $a = 9.026^2 \times .7854 = 64$  sq. ft. Hence,  $q = av = 64 \times 330 = 21,120$  cu. ft. per minute. Ans.

**965.** If the quantity to be discharged and the sectional area are known, and it is required to find the velocity, use the following formula:

$$v = \frac{q}{a}. \quad (44.)$$

*That is, the velocity in feet per minute equals the quantity passing in cubic feet per minute divided by the sectional area in square feet.*

**EXAMPLE.**—A circular airway has a diameter of 9.026 feet; what must be the velocity in order to pass 21,120 cubic feet per minute?

**SOLUTION.**—The sectional area was found to be 64 square feet in the last example. Hence, substituting in formula 44,

$$v = \frac{q}{a} = \frac{21,120}{64} = 330 \text{ ft. per minute. Ans.}$$

**966.** The size of the airway usually depends upon other considerations than the quantity and velocity; but, in order to render the subject more complete, the following formula is given:

$$a = \frac{q}{v}. \quad (45.)$$

*That is, the sectional area equals the quantity in cubic feet per minute divided by the velocity in feet per minute.*

**967.** Formulas 43, 44, and 45 may be combined with formulas 28 to 32, so that the pressure (or velocity) may be determined at once, when the quantity and other needful data are known; but the simplest way is to calculate the velocity by formula 40, and then substitute the value obtained in formula 43 to find the quantity; or to calculate

the velocity by formula 44, and substitute in formula 37 or 38 to find the pressure. The formulas are given, however, in Table 24, and are there denoted by the letters **a**, **b**, **c**, etc., to distinguish them from the numbered formulas, which are considered to be more important.

**EXAMPLE.**—What is the total ventilating pressure required to pass 21,120 cubic feet of air per minute through an 8' × 8' air-course 6,000 feet long?

**SOLUTION.**—The sectional area =  $8 \times 8 = 64$  sq. ft. = *a*. The rubbing surface =  $8 \times 4 \times 6,000 = 192,000$  sq. ft. = *s*.

By formula 44,

$$v = \frac{q}{a} = \frac{21,120}{64} = 330 \text{ ft. per minute.}$$

Therefore, applying formula 37,

$$P = k s v^2 = .000000217 \times 192,000 \times 330^2 = 453.72 \text{ lb. Ans.}$$

### WORK AND POWER.

**968.** **Work** is equal to resistance in pounds multiplied by the space in feet through which the resistance is overcome. That is, suppose that it takes a force (pressure) of 25 pounds to move a certain body; then, if the resistance is uniform, as, for example, in lifting a weight, and the body is moved through a distance of 36 feet, the work done is  $25 \times 36 = 900$  foot-pounds. Since time is not mentioned in the above definition, it follows that work is independent of the time; that is, no matter whether it takes 1 second or 1 year to move the body 36 feet, the work done is 900 foot-pounds.

Now, in order to compare the work done by different machines, time must be considered. Hence, the amount of work done in overcoming a resistance of 1 pound, through a space (distance) of 1 foot in 1 minute, is called the **unit of power**. The power of a machine is, then, the number of foot-pounds of work which it can perform in 1 minute, and this number divided by 33,000 is called the **horsepower of the machine**.

The power required to produce the proper ventilative effects may be easily calculated when the total pressure and

the velocity are known, or when the pressure per square foot and the quantity passed in cubic feet per minute are known. Thus, the total pressure represents the force required to overcome the resistances, and the velocity in feet per minute represents the space (distance) passed through in 1 minute; consequently, the product of the total pressure,  $P$ , and the velocity in feet per minute equals the work per minute, or the power. That is, representing the number of units of power by  $u$ ,

$$u = Pv. \quad (46.)$$

Likewise, since  $P = pa$ ,  $u = pav$ ; but, according to formula 43,  $av = q$ ; hence,

$$u = pq. \quad (47.)$$

By dividing formulas 46 and 47 by 33,000, the horsepower may be found. Letting  $H$  represent the horsepower,

$$H = \frac{u}{33,000} = \frac{Pv}{33,000} = \frac{pav}{33,000} = \frac{pq}{33,000}. \quad (48.)$$

EXAMPLE.—What horsepower is required to pass the air in the last example?

SOLUTION.—The total pressure was found to be 453.72 pounds, and the velocity 330 feet per minute. Hence, by formula 48,

$$H = \frac{Pv}{33,000} = \frac{453.72 \times 330}{33,000} = 4.537 \text{ H. P., nearly. Ans.}$$

EXAMPLE.—If the water-gauge reading is 1.9 inches, and the quantity of air passing is 20,000 cubic feet per minute, what horsepower is required?

SOLUTION.—The pressure per square foot =  $5.2 \times 1.9 = 9.88$  lb. Therefore, applying formula 48,

$$H = \frac{pq}{33,000} = \frac{9.88 \times 20,000}{33,000} = 6 \text{ H. P., nearly. Ans.}$$

**969.** From formula 48, several other important formulas may be derived by a simple transposition of the terms. If the horsepower, sectional area, and the velocity of the air are known, and it is desired to find the ventilating pressure in pounds per square foot, the following formula may be used:

$$p = \frac{33,000 H}{av}. \quad (49.)$$

Or, if the horsepower and the quantity of air to be passed per minute are known, and  $p$  is required,

$$p = \frac{33,000 H}{q}. \quad (50.)$$

**970.** If it be required to ascertain the quantity which a certain horsepower will cause to pass with a given pressure, it may be found by formula **51**,

$$q = \frac{33,000 H}{p}. \quad (51.)$$

Similarly, the velocity may be found by formula **52**, when the horsepower and total pressure, or the horsepower, pressure per square foot, and sectional area are known.

$$v = \frac{33,000 H}{P} = \frac{33,000 H}{p a}. \quad (52.)$$

**EXAMPLE.**—It is required to pass 20,000 cubic feet of air per minute. (a) What is the pressure per square foot if only 6 horsepower are required? (b) What is the water-gauge reading?

**SOLUTION.**—(a) Since only the horsepower and quantity are given, formula **50** must be used. Substituting,

$$p = \frac{33,000 H}{q} = \frac{33,000 \times 6}{20,000} = 9.9 \text{ lb. per square foot. Ans.}$$

$$(b) \text{ Since } p = 5.2 W, W = \frac{p}{5.2} = \frac{9.9}{5.2} = 1.9 \text{ in., very nearly. Ans.}$$

**EXAMPLE.**—Had the sectional area in the above example been 50 square feet, what would the velocity have been?

**SOLUTION.**—This example may be solved in two ways. By formula **44**,

$$v = \frac{q}{a} = \frac{20,000}{50} = 400 \text{ ft. per minute. Ans.}$$

By formula **52**,

$$v = \frac{33,000 H}{p a} = \frac{33,000 \times 6}{9.9 \times 50} = 400 \text{ ft. per minute. Ans.}$$

**971.** Formulas **46** to **52** may be combined with formulas **37** to **42** to produce other formulas, which will shorten the work to some extent in certain cases; but the student will find it a better plan, as a rule, to calculate the pressure, velocity, or whatever he needs, by using one of

the formulas from **36** to **44**, and then substituting in one of the later formulas.

A number of these combination formulas will be given in Table 24, and the student may use them if he so chooses. One of these combination formulas is so important that it will now be given.

Multiplying both sides of formula **37** by  $v$ ,  $Pv = ksv^2$ ; but by formula **46**,  $Pv = u$ ; hence,

$$u = ksv^2. \quad (53.)$$

*That is, the power in foot-pounds per minute equals the continued product of the coefficient of friction, the rubbing surface, and the cube of the velocity.*

Likewise, since  $u = pq$  (formula **47**),  $pq = ksv^2$ ; or,

$$q = \frac{ksv^2}{p}. \quad (54.)$$

**EXAMPLE.**—An air-course has a length of 4,752 feet; its perimeter is 30 feet, and its sectional area is 50 square feet. (a) What quantity of air will it pass at a velocity of 400 feet per minute? (b) What power will be required? The pressure is 9.9 pounds per square foot.

**SOLUTION.**—(a) This question is most easily solved by means of formula **43**, but to show the reliability of formula **54**, it will be solved both ways. By formula **43**,

$$q = av = 50 \times 400 = 20,000 \text{ cu. ft. per minute. Ans.}$$

By formula **54**, since  $s = 4,752 \times 30 = 142,560$  sq. ft.

$$q = \frac{ksv^2}{p} = \frac{.0000000217 \times 142,560 \times 400^2}{9.9} = 20,000 \text{ cu. ft., nearly. Ans.}$$

(b) Substituting in formula **53**,

$$u = ksv^2 = .0000000217 \times 142,560 \times 400^2 = 198,000 \text{ ft.-lb. per minute, nearly,} = \frac{198,000}{33,000} = 6 \text{ H. P. Ans.}$$

**972.** There is one more combination formula which is chiefly valuable on account of the deductions which may be made from considerations of it, and which will now be given in order that the student may be able to answer a question sometimes asked at examinations for mine foremen's certificates. But, in order that an intelligent understanding may result, it is necessary to digress here and explain a certain geometrical law.

**973.** Two figures are **similar** when the smaller may be so placed within the larger that their perimeters shall be parallel throughout their entire lengths, and their corresponding sides proportional. Thus, if in Fig. 139 the perimeters of

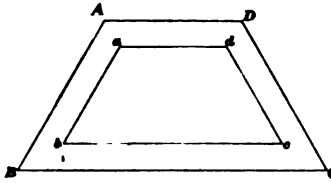

FIG. 139.

the two trapezoids are parallel when one is placed within the other, and  $AD : ad :: BC : bc$ , and the same relation is also true of any other two sides, as  $AD : ad :: DC : dc$ , then the two trapezoids are *similar*. Equilateral triangles, squares, and circles are always similar.

Now, it is proved in geometry that the areas of similar figures are to each other as the squares of any side, the squares of their perimeters, or the squares of any line similarly placed in them, as, for example, a diagonal or diameter. Also, that the volumes of similar solids are to each other as the cubes of similarly placed lines in them. Likewise, if *any* two similar figures are varied according to some power of similarly placed lines, all similar figures will vary according to the same powers of their similarly placed lines. For example, if the volume of a certain prism is 21 cubic inches and the length of a certain line in it is 2 inches, what will be the volume of a similar prism if the length of a similarly placed line in it is 3 inches? Since the volumes of similar solids are to each other as the cubes of their similar lines,  $2^3 : 3^3 :: 21 : x$ ; or,  $x = \frac{21 \times 27}{8} = 70.875$  cubic inches.

**974.** Returning now to the subject of ventilation, consider a mine having a square cross-section, and represent the length of a side by  $d$ . Then the area is  $d^2$  and the perimeter is  $4d$ . According to formula 43,  $q = av$ ; but, since for this case  $a = d^2$ ,  $q = d^2v$ . By formula 40,  $v = \sqrt{\frac{pa}{ks}} = \sqrt{\frac{pd^2}{ks}}$ , since  $a = d^2$ . By formula 42,  $s = lo$ , and since for this case  $o = 4d$ ,  $s = l \times 4d = 4ld$ . Substituting

this value of  $s$  in the above formula for  $v$ ,  $v = \sqrt{\frac{pd^3}{k \times 4ld}} = \sqrt{\frac{pd}{4kl}}$ . Substituting this value of  $v$  in the expression giving the value of  $q$ ,

$$q = d^3 \times \sqrt{\frac{pd}{4kl}}; \text{ or, } q = \sqrt{\frac{pd^5}{4kl}}. \quad (55.)$$

**975.** It must be remembered that formula 55 applies only to square airways. A consideration of it shows that if two square airways have the same length and pressure per square foot, the quantities of air which they will pass will be to each other as the square roots of the fifth powers of the lengths of their sides.

Also, if two square airways of different lengths are required to pass the same quantity of air with the same pressure per square foot, the lengths of the sides will be to each other as the fifth roots of the lengths of the airways.

Now, since squares are similar figures, the two statements just made will also apply to any two airways whose cross-sections are similar figures.

**976.** The following example is a question asked at an examination held at Pittsburg, in March, 1893:

**EXAMPLE.**—If 15,000 cubic feet of air per minute are passing through an airway 4,000 feet in length, and 6 feet by 8 feet in section, what should be the dimensions of the section of another airway of precisely the same form (i. e., a similar section) to pass the same quantity of air, the length, however, being 3,000 feet, instead of 4,000 feet, as in the former case?

**SOLUTION.**—Since the pressure is not stated, it is evidently intended to be the same in both cases. Then, according to the above statements, the lengths of similar sides are to each other as the fifth roots of the lengths. Hence,  $6 : x :: \sqrt[5]{4,000} : \sqrt[5]{3,000}$ ;

$$\text{or, } x = 6 \times \frac{\sqrt[5]{3,000}}{\sqrt[5]{4,000}} = 6 \sqrt[5]{\frac{3,000}{4,000}} = 6 \times .944 = 5.664 \text{ ft.}$$

Now, since the sections are similar, the sides are proportional; hence,  $6 : 5.664 :: 8 : x$ ; or,  $x = \frac{5.664 \times 8}{6} = 7.552 \text{ ft.}$  Therefore, the section is  $5.664' \times 7.552'$ . Ans.



**977.** From formula **55** there may also be deduced the proposition that if two square airways have the same length and pass the same quantities of air, the lengths of the sides of the airway will then vary *inversely* as the fifth roots of the pressures. This statement applies, of course, to airways of similar sections. Conversely, the pressures vary inversely as the fifth powers of the lengths of the sides.

A method of finding the fifth roots of numbers will be given hereafter. (See Art. **1000**.)

**978. Other Resistances.**—All that is necessary for the calculation of the resistance of the flow of air through a straight airway has now been given, and all that remains to be considered, so far as appertains to the flow of air, are those effects produced by bends, contractions, or enlargements of the sections, and splits. Each of the foregoing results in a change in the velocity of the flowing air, and, consequently, in a change in the ventilating pressure. The losses due to bends are considerable, particularly a bend of  $90^\circ$  or greater. Where a bend is absolutely necessary, the corners should be rounded (if practicable) to as large a radius as possible, if it is desired to reduce the mine resistance to a minimum. There is no reliable formula for calculating the resistance due to bends, but they certainly reduce the velocity to a great extent, especially a bend of  $90^\circ$  or greater. If the reduction or enlargement of the sectional area is slight compared with the sectional area of the airway, the consequent loss of velocity may be disregarded entirely. In any case, it is a difficult matter to decide how much to allow for such loss. The losses due to regulators and to splits will be treated separately in a later section. Since, as before mentioned, the coefficient of friction, .000000217, is very high, much above what would actually be obtained in practice for a straight airway, the losses due to bends, enlargements, and contractions may be neglected altogether without any material error, the airway being calculated as if it were straight and of uniform section through-

out. This statement applies, of course, to slight enlargements or contractions.

**979. Formulas.**—Formulas 36 to 54, inclusive, and others which are not quite as important, are given in Table 24, so as to be convenient for reference. The formulas not previously given are denoted by the letters **a, b, c**, etc. A specimen calculation is also worked out with each formula. To prevent any misconception, the letters and their meanings are repeated below:

- $a$  = sectional area of airway in square feet;
- $H$  = horsepower;
- $k$  = coefficient of friction = .0000000217;
- $l$  = length of airway in feet;
- $o$  = perimeter of airway in feet;
- $p$  = ventilating pressure in pounds per square foot;
- $P$  = total ventilating pressure in pounds;
- $q$  = quantity of air in cubic feet per minute;
- $s$  = rubbing surface in square feet;
- $u$  = units of power in foot-pounds per minute;
- $v$  = velocity in feet per minute;
- $W$  = water-gauge in inches of water.

To render the formulas more convenient for reference, they are not given in sequence according to their numbers, but are classified according to the letters whose values it is desired to find, the letters having the meaning given above.

The basis for the calculations is an airway 5 feet wide by 4 feet high and 2,000 feet long, the velocity to be 500 feet per minute.

TABLE 24.

Formulas.	Specimen Calculations.
<b>To find the area :</b>	
$a = \frac{P}{p}$ (a.)	$a = \frac{195.3}{9.765} = 20 \text{ sq. ft. Ans.}$
$a = \frac{k s v^3}{p}$ (a'.)	$a = \frac{.0000000217 \times 36,000 \times 500^3}{9.765} = 20 \text{ sq. ft. Ans.}$
$a = \frac{q}{v}$ (45.)	$a = \frac{10,000}{500} = 20 \text{ sq. ft. Ans.}$
$a = \frac{u}{p v}$ (b.)	$a = \frac{97,650}{9.765 \times 500} = 20 \text{ sq. ft. Ans.}$
$a = \frac{33,000 H}{p v}$ (c.)	$a = \frac{33,000 \times 2.959}{9.765 \times 500} = 20 \text{ sq. ft. Ans.}$
$a = \frac{k s v^3 q}{u}$ (d.)	$a = \frac{.0000000217 \times 36,000 \times 500^3 \times 10,000}{97,650} = 20 \text{ sq. ft. Ans.}$
<b>To find the horsepower :</b>	
$H = \frac{u}{33,000}$ (45.)	$H = \frac{97,650}{33,000} = 2.959 \text{ horsepower. Ans.}$
$H = \frac{P v}{33,000}$ (46.)	$H = \frac{195.3 \times 500}{33,000} = 2.959 \text{ horsepower. Ans.}$
$H = \frac{p q}{33,000}$ (46.)	$H = \frac{9.765 \times 10,000}{33,000} = 2.959 \text{ horsepower. Ans.}$

TABLE 24—Continued.

Formulas.	Specimen Calculations.
$H = \frac{p a v}{33,000}.$ (48.)	$H = \frac{9.765 \times 20 \times 500}{33,000} = 2.959$ horsepower. Ans.
<p>To find the coefficient of friction :</p>	
$k = \frac{P}{s v^3}.$ (e.)	$k = \frac{195.3}{36,000 \times 500^3} = .0000000217$ lb. per sq. ft. per minute. Ans.
$k = \frac{p a}{s v^3}.$ (f.)	$k = \frac{9.765 \times 20}{36,000 \times 500^3} = .0000000217$ lb. per sq. ft. per minute. Ans.
$k = \frac{u}{s v^3}.$ (g.)	$k = \frac{97.650}{36,000 \times 500^3} = .0000000217$ lb. per sq. ft. per minute. Ans.
$k = \frac{p q}{s v^3}.$ (h.)	$k = \frac{9.765 \times 10,000}{36,000 \times 500^3} = .0000000217$ lb. per sq. ft. per minute. Ans.
<p>To find the length of the airway :</p>	
$l = \frac{s}{o}.$ (41.)	$l = \frac{36,000}{18} = 2,000$ ft. Ans.
<p>To find the perimeter of the airway :</p>	
$o = \frac{s}{l}.$ (1.)	$o = \frac{36,000}{2,000} = 18$ ft. Ans.

TABLE 24—Continued.

Formulas.	Specimen Calculations.
<b>To find the total pressure:</b>	
$P = p a.$ (36.)	$P = 9.765 \times 20 = 195.3 \text{ lb. Ans.}$
$P = k s v^3.$ (37.)	$P = .0000000217 \times 36,000 \times 500^3 = 195.3 \text{ lb. Ans.}$
$P = \frac{u}{v}.$ (J.)	$P = \frac{97,650}{500} = 195.3 \text{ lb. Ans.}$
$P = \frac{33,000 H}{v}.$ (K.)	$P = \frac{33,000 \times 2,959}{500} = 195.3 \text{ lb. Ans.}$
$P = \frac{k s q^3}{a^3}.$ (L.)	$P = \frac{.0000000217 \times 36,000 \times 10,000^3}{20^3} = 195.3 \text{ lb. Ans.}$
<b>To find the pressure in pounds per square foot:</b>	
$p = \frac{P}{a}.$ (M.)	$p = \frac{195.3}{20} = 9.765 \text{ lb. per square foot. Ans.}$
$p = \frac{k s v^3}{a}.$ (38.)	$p = \frac{.0000000217 \times 36,000 \times 500^3}{20} = 9.765 \text{ lb. per square foot. Ans.}$
$p = \frac{u}{q}.$ (N.)	$p = \frac{97,650}{10,000} = 9.765 \text{ lb. per square foot. Ans.}$
$p = \frac{33,000 H}{a v}.$ (49.)	$p = \frac{33,000 \times 2,959}{20 \times 500} = 9.765 \text{ lb. per square foot. Ans.}$
$p = \frac{33,000 H}{q}.$ (50.)	$p = \frac{33,000 \times 2,959}{10,000} = 9.765 \text{ lb. per square foot. Ans.}$

TABLE 24—Continued.

Formulas.	Specimen Calculations.
$p = \frac{k s v^3}{q}$ (0.)	$p = \frac{.0000000217 \times 36,000 \times 500^3}{10,000} = 9,765$ lb. per square foot. Ans.
$p = \frac{k s q^3}{a^3}$ (0.)	$p = \frac{.0000000217 \times 36,000 \times 10,000^3}{20^3} = 9,765$ lb. per square foot. Ans.
$p = 5.3 W$ .	$p = 5.3 \times 1.87788 = 9,765$ lb. per square foot. Ans.
<b>To find the quantity of air passing in cubic feet per minute :</b>	
$q = a v$ (43.)	$q = 20 \times 500 = 10,000$ cu. ft. per minute. Ans.
$q = \frac{u}{p}$ (P.)	$q = \frac{97,650}{9,765} = 10,000$ cu. ft. per minute. Ans.
$q = \frac{38,000 H}{p}$ (51.)	$q = \frac{38,000 \times 2,959}{9,765} = 10,000$ cu. ft. per minute. Ans.
$q = \frac{k s v^3}{p}$ (54.)	$q = \frac{.0000000217 \times 36,000 \times 500^3}{9,765} = 10,000$ cu. ft. per minute. Ans.
$q = a \sqrt{\frac{p a}{k s}}$ (Q.)	$q = 20 \sqrt{\frac{9,765 \times 20}{.0000000217 \times 36,000}} = 10,000$ cu. ft. per minute. Ans.
<b>To find the rubbing surface in square feet :</b>	
$s = \frac{P}{k v^3}$ (39.)	$s = \frac{195.3}{.0000000217 \times 500^3} = 36,000$ sq. ft. Ans.
$s = \frac{p a}{k v^3}$ (39.)	$s = \frac{9,765 \times 20}{.0000000217 \times 500^3} = 36,000$ sq. ft. Ans.

TABLE 24—Continued.

Formulas.	Specimen Calculations.
$s = l o.$ (42.)	$s = 2,000 \times 18 = 36,000$ sq. ft. Ans.
$s = \frac{u}{k v^2}.$ (r.)	$s = \frac{97,650}{.0000000217 \times 500^2} = 36,000$ sq. ft. Ans.
$s = \frac{p q}{k v^3}.$ (s.)	$s = \frac{9,765 \times 10,000}{.0000000217 \times 500^3} = 36,000$ sq. ft. Ans.
To find the units of power in foot-pounds per minute:	
$u = P v.$ (46.)	$u = 195.3 \times 500 = 97,650$ ft.-lb. per minute. Ans.
$u = p q.$ (47.)	$u = 9,765 \times 10,000 = 97,650$ ft.-lb. per minute. Ans.
$u = 33,000 H.$ (t.)	$u = 33,000 \times 2,959 = 97,650$ ft.-lb. per minute. Ans.
$u = p a v.$ (u.)	$u = 9,765 \times 20 \times 500 = 97,650$ ft.-lb. per minute. Ans.
$u = k s v^3.$ (53.)	$u = .0000000217 \times 36,000 \times 500^3 = 97,650$ ft.-lb. per minute. Ans.
$u = \frac{k s q^2}{a^3}$ (u'.)	$u = \frac{.0000000217 \times 36,000 \times 10,000^2}{20^3} = 97,650$ ft.-lb. per minute. Ans.
To find the velocity in feet per minute:	
$v = \sqrt{\frac{p a}{k s}}.$ (40.)	$v = \sqrt{\frac{9,765 \times 20}{.0000000217 \times 36,000}} = 500$ ft. per minute. Ans.
$v = \sqrt{\frac{P}{k s}}.$ (v.)	$v = \sqrt{\frac{195.3}{.0000000217 \times 36,000}} = 500$ ft. per minute. Ans.

TABLE 24—Concluded.

Formulas.	Specimen Calculations.
$v = \frac{q}{a}$ (44.)	$v = \frac{10,000}{20} = 500$ ft. per minute. Ans.
$v = \frac{u}{p}$ (w.)	$v = \frac{97,650}{195.3} = 500$ ft. per minute. Ans.
$v = \frac{u}{p a}$ (x.)	$v = \frac{97,650}{9,765 \times 20} = 500$ ft. per minute. Ans.
$v = \frac{38,000 H}{P}$ (y.)	$v = \frac{38,000 \times 2,959}{195.3} = 500$ ft. per minute. Ans.
$v = \frac{38,000 H}{p a}$ (y')	$v = \frac{38,000 \times 2,959}{9,765 \times 20} = 500$ ft. per minute. Ans.
$v = \sqrt[3]{\frac{u}{k s}}$ (z.)	$v = \sqrt[3]{\frac{97,650}{.0000000217 \times 36,000}} = 500$ ft. per minute. Ans.
$v = \sqrt[3]{\frac{p q}{k s}}$ (z')	$v = \sqrt[3]{\frac{9,765 \times 10,000}{.0000000217 \times 36,000}} = 500$ ft. per minute. Ans.
To find the water-gauge:	
$W = \frac{p}{5.2}$	$W = \frac{9,765}{5.2} = 1.87788$ in. Ans.

NOTE.—The water-gauge is calculated to five decimal places, so that it will correspond to the other values; two places are sufficient in practice.



### LAWS OF VENTILATION.

**980.** In order to ascertain the effects produced by varying the airway or by varying the quantity, velocity, etc., of the air, it is generally easier to make use of one of the following *laws* than to solve by means of one of the foregoing formulas. The laws are also useful for comparing the results obtained from two airways. Letting  $p, q, v, s$ , etc., represent, respectively, the pressure, quantity, velocity, rubbing surface, etc., before the change, and  $p_1, q_1, v_1, s_1$ , etc., the same things after the change, the laws may be stated as follows:

(1) The pressure varies directly as the extent of the rubbing surface; i. e.,  $p : p_1 :: s : s_1$ , or  $P : P_1 :: s : s_1$ .

(2) The pressure varies directly as the density\* of the air; i. e.,  $p : p_1 :: w : w_1$ , or  $P : P_1 :: w : w_1$ .

(3) The pressure varies directly as the square of the quantity; i. e.,  $p : p_1 :: q^2 : q_1^2$ , or  $P : P_1 :: q^2 : q_1^2$ .

(4) The pressure varies directly as the square of the velocity; i. e.,  $p : p_1 :: v^2 : v_1^2$ , or  $P : P_1 :: v^2 : v_1^2$ .

(5) The pressure varies directly as the length of the airway; i. e.,  $p : p_1 :: l : l_1$ , or  $P : P_1 :: l : l_1$ .

(6) The pressure varies directly as the length of the perimeter; i. e.,  $p : p_1 :: o : o_1$ , or  $P : P_1 :: o : o_1$ .

(7) The pressure per square foot varies inversely as the area of the airway; i. e.,  $p : p_1 :: a_1 : a$ .

(8) The quantity varies directly as the square root of the pressure; i. e.,  $q : q_1 :: \sqrt{p} : \sqrt{p_1}$ , or  $q : q_1 :: \sqrt{P} : \sqrt{P_1}$ .

(9) The quantity varies directly as the cube root of the power; i. e.,  $q : q_1 :: \sqrt[3]{u} : \sqrt[3]{u_1}$ , or  $q : q_1 :: \sqrt[3]{H} : \sqrt[3]{H_1}$ .

(10) The quantity varies inversely as the square root of the rubbing surface; i. e.,  $q : q_1 :: \sqrt{s_1} : \sqrt{s}$ .

(11) The velocity varies directly as the square root of the pressure; i. e.,  $v : v_1 :: \sqrt{p} : \sqrt{p_1}$ , or  $v : v_1 :: \sqrt{P} : \sqrt{P_1}$ .

\*By density is meant the *weight of a cubic foot in pounds*.

(12) The velocity varies directly as the square root of the area; i. e.,  $v : v_1 :: \sqrt{a} : \sqrt{a_1}$ .

(13) The velocity varies inversely as the square root of the length of the airway; i. e.,  $v : v_1 :: \sqrt{l_1} : \sqrt{l}$ .

(14) The velocity varies inversely as the square root of the rubbing surface; i. e.,  $v : v_1 :: \sqrt{s_1} : \sqrt{s}$ .

(15) The power varies directly as the cube of the quantity; i. e.,  $u : u_1 :: q^3 : q_1^3$ , or  $H : H_1 :: q^3 : q_1^3$ .

(16) The rubbing surface varies inversely as the square of the quantity; i. e.,  $s : s_1 :: q_1^2 : q^2$ .

(17) The rubbing surface varies inversely as the square of the velocity; i. e.,  $s : s_1 :: v_1^2 : v^2$ .

(18) The sectional area varies directly as the square of the velocity; i. e.,  $a : a_1 :: v^2 : v_1^2$ .

(19) The length of the airway varies inversely as the square of the velocity; i. e.,  $l : l_1 :: v_1^2 : v^2$ .

(20) The length of the airway varies inversely as the square of the quantity; i. e.,  $l : l_1 :: q_1^2 : q^2$ .

For similar airways, let  $d$  equal the length of a side; then,

(21) The quantity varies directly as the square root of the fifth power of the length of the side; i. e.,  $q : q_1 :: \sqrt{d^5} : \sqrt{d_1^5}$ .

(22) The pressure varies inversely as the fifth power of the length of the side; i. e.,  $p : p_1 :: d_1^5 : d^5$ .

(23) The length of the side varies inversely as the fifth root of the pressure; i. e.,  $d : d_1 :: \sqrt[5]{p_1} : \sqrt[5]{p}$ .

(24) The length of the side varies directly as the fifth root of the square of the quantity; i. e.,  $d : d_1 :: \sqrt[5]{q^2} : \sqrt[5]{q_1^2}$ .

To the above laws may also be added another:

(25) If equal quantities of air pass through two airways, the velocities will vary inversely as the areas; i. e.,  $v : v_1 :: a_1 : a$ .

## PRACTICAL PROBLEMS.

**981.** To illustrate the application of the foregoing laws and formulas, a series of practical examples such as are asked at examinations for mine foremen, together with their solutions, will now be given. By paying particular and careful attention to the statements of the examples and the solutions following them, the student should then be able to work similar ones without trouble. The above twenty-five laws should be carefully memorized, so that the student will not be obliged to refer to them.

1. What quantity of air is passing down a shaft 12 feet in diameter when the current has a velocity of 325 feet per minute?

SOLUTION.—Since the diameter is specified, the shaft is evidently circular. Applying formula 43,

$$q = av = 12^2 \times .7854 \times 325 = 36,756.72 \text{ cu. ft. per minute. Ans.}$$

2. Where the airway is 12 feet wide at the bottom, 10 ft. 4 in. wide at the top, and 6 ft. 6 in. high, and the velocity of the air is 340 feet per minute, what is (a) the sectional area of the airway, and (b) the quantity of air passing per minute?

SOLUTION.—(a) The section is a trapezoid; hence,

$$\text{area} = \frac{10\frac{1}{2} + 12}{2} \times 6\frac{1}{2} = 72\frac{7}{16} \text{ sq. ft.,}$$

$$\text{since 4 in.} = \frac{1}{3} \text{ ft., and 6 in.} = \frac{1}{2} \text{ ft. Ans.}$$

(b) Applying formula 43,

$$q = av = 72\frac{7}{16} \times 340 = 24,678\frac{1}{2} \text{ cu. ft. per minute. Ans.}$$

3. If a shaft 8 ft. by 24 ft. in section is the intake, and the fan is exhausting 160,000 cubic feet of air per minute, what is the velocity of the air-current in the shaft?

SOLUTION.—Applying formula 44,

$$v = \frac{q}{a} = \frac{160,000}{8 \times 24} = 833\frac{1}{3} \text{ ft. per minute. Ans.}$$

4. The section of an airway is a right-angled triangle, 10 feet wide at the base and 7½ feet high; what quantity of air is passing when the velocity is 280 feet per minute?

SOLUTION.—Area of section =  $\frac{10 \times 7.5}{2} = 37.5 \text{ sq. ft.}$  Then, applying formula 43,

$$q = av = 37.5 \times 280 = 10,500 \text{ cu. ft. per minute. Ans.}$$

5. An air-course is 500 yards long, 6 feet high, and 7 feet wide; what is (a) its sectional area, (b) its perimeter, and (c) its rubbing surface?

SOLUTION.—(a) Sectional area  $a = 6 \times 7 = 42$  sq. ft. Ans.

(b) Perimeter  $o = 6 \times 2 + 7 \times 2 = 26$  ft. Ans.

(c) Applying formula 42,

$$s = lo = 500 \times 3 \times 26 = 39,000 \text{ sq. ft. Ans.}$$

6. The rubbing surface is 25,000 sq. ft. and the perimeter 50 ft.; what is the length?

SOLUTION.—Applying formula 41,

$$l = \frac{s}{o} = \frac{25,000}{50} = 500 \text{ ft. Ans.}$$

7. When the water-gauge is 1.85 in., what pressure per square foot does it indicate?

SOLUTION.— $p = 5.2W = 5.2 \times 1.85 = 9.62$  lb. per square foot. Ans.

8. What is the total ventilating pressure of an airway 6 feet by 7 feet, the water-gauge being .5 of an inch?

SOLUTION.—Pressure per square foot  $= 5.2 \times .5 = 2.6$  lb.; area  $= 6 \times 7 = 42$  sq. ft. Applying formula 36,

$$P = pa = 2.6 \times 42 = 109.2 \text{ lb. Ans.}$$

9. What quantity of air is passing through an airway 7 feet high by 7 feet wide when the velocity of the current is 300 feet per minute?

SOLUTION.—Applying formula 43,

$$q = av = 7 \times 7 \times 300 = 14,700 \text{ cu. ft. per minute. Ans.}$$

10. If 80,000 cubic feet of air are required per minute in a mine, and the shaft velocity must not exceed 800 feet per minute, what is the smallest sectional area that the shaft may have?

SOLUTION.—Using formula 45,

$$a = \frac{q}{v} = \frac{80,000}{800} = 100 \text{ sq. ft. Ans.}$$

11. Suppose a gangway 10 feet by 10 feet and 1,000 feet long, in which the air has a velocity of 450 feet per minute, and the pressure as indicated by the water-gauge is 2 pounds; what is (a) the water-gauge reading, (b) the quantity of air passing per minute, and (c) the horsepower?

SOLUTION.—(a) Water-gauge  $= W = \frac{2}{5.2} = .38$  in. Ans.

(b) Applying formula 43,

$$q = av = 10 \times 10 \times 450 = 45,000 \text{ cu. ft. per minute. Ans.}$$

(c) Using formula 48,

$$H = \frac{p q}{33,000} = \frac{2 \times 45,000}{33,000} = 2.727 \text{ H. P. Ans.}$$

12. If you have two airways under the same pressure, one 6 feet wide, 6 feet high, and 5,000 feet long, the other 8 feet wide, 4½ feet high, and 5,000 feet long, which will pass the greater quantity of air, and why?

SOLUTION.—Since the pressure and length remain the same, it is evident that the airway having the smaller perimeter will pass the greater quantity, since the rubbing surface will be less; perimeter of first airway =  $6 \times 4 = 24$  ft.; of the second airway,  $8 \times 2 + 4\frac{1}{2} \times 2 = 25$  ft. Representing by 1 the amount passed by the first airway, and applying law (10),  $1 : q_1 :: \sqrt[4]{25} : \sqrt[4]{24}$ , or  $q_1 = .98$ ; i. e., the second airway will pass 98% of the amount passed by the first airway. Ans.

13. The pressure producing ventilation is 7.8 pounds per square foot; what is the water-gauge?

$$\text{SOLUTION.— } W = \frac{p}{5.2} = \frac{7.8}{5.2} = 1.5 = 1\frac{1}{2} \text{ in. Ans.}$$

14. When the quantity of air passing is 60,000 cubic feet, with a water-gauge of 1.5 inches, what are the units of power producing ventilation?

SOLUTION.—Pressure =  $p = 5.2 W = 5.2 \times 1.5 = 7.8$  lb. per square foot. Using formula 47,

$$u = p q = 7.8 \times 60,000 = 468,000 \text{ ft. lb. per minute. Ans.}$$

15. How many horsepower are represented by 468,000 units of power?

SOLUTION.—Using formula 48,

$$H = \frac{u}{33,000} = \frac{468,000}{33,000} = 14.18 \text{ H. P., nearly. Ans.}$$

16. With a water-gauge of  $\frac{1}{10}$  of an inch, the quantity of air passing is 24,000 cubic feet per minute; what water-gauge will be required to pass 36,000 cubic feet per minute?

SOLUTION.—Since the water-gauge and pressure are directly proportional to each other, law (3) may be applied; or,

$$24,000^2 : 36,000^2 :: .6 : x; \text{ whence, } x = 1.35 \text{ in. of water. Ans.}$$

17. If 16,500 cubic feet of air are passing per minute with a pressure of 4.68 pounds per square foot, what quantity will pass with a pressure of 6.24 pounds per square foot?

SOLUTION.—Applying law (8),

$$16,500 : q_1 :: \sqrt[4]{4.68} : \sqrt[4]{6.24}; \text{ or, } q_1 = 19,052 \text{ cu. ft. per minute. Ans.}$$

18. If 3 horsepower pass 15,000 cubic feet of air per minute, what horsepower would be required to double the quantity?

SOLUTION.—Applying law (15),

$$3 : H_1 :: 15,000^3 : (15,000 \times 2)^3; \text{ or, } H_1 = 24 \text{ H. P. Ans.}$$

19. Is there any disadvantage or loss in having the air travel at a high speed?

SOLUTION.—There is a very decided loss; for, according to the third law of friction, the pressure varies as the square of the velocity. If, therefore, the velocity is to be doubled, the pressure must be increased as the *square of two*; that is, four times. If the velocity is to be trebled, the pressure must be increased as the square of three; that is, nine times.

20. If 32,000 cubic feet of air are passing through an airway 6' × 5', under a pressure of 3.6 pounds per square foot, what pressure is necessary in an airway 9' × 5' to pass the same quantity?

SOLUTION.—Call the resistance of the first airway  $A$ , and that of the second one  $B$ , and call the required pressure  $x$ ; then,  $A : B :: 3.6 : x$ , or  $x = \frac{B}{A} \times 3.6$ , because the pressures vary directly as the resistances.

$$x = \frac{\left(\frac{32,000}{45}\right)^2 \times \frac{28}{45} \times 3.6}{\left(\frac{32,000}{80}\right)^2 \times \frac{28}{80}}; \text{ or, by cancelation, } x = \frac{\frac{28}{45^3} \times 3.6}{\frac{28}{80^3}}$$

Further,  $x = \frac{30^3}{22} \times \frac{28}{45^3} \times 3.6 = \frac{2^3}{11} \times \frac{14}{3^3} \times 3.6 = 1.3575 \text{ lb.}$ , the required pressure per square foot. Ans.

21. If a pressure of 3.2 pounds per square foot produces a velocity of 560 feet per minute, what pressure is required to produce a velocity of 700 feet per minute in the same airway?

SOLUTION.—Applying law (4),

$$3.2 : p_1 :: 560^3 : 700^3; \text{ whence, } p_1 = 5 \text{ lb. per square foot. Ans.}$$

22. If 24,000 cubic feet are passing through an airway having a rubbing surface of 75,000 square feet, what quantity will pass if the rubbing surface is increased to 100,000 square feet, the increase of rubbing surface being due to the lengthening of the airway?

SOLUTION.—Applying law (10),

$$24,000 : q_1 :: \sqrt{100,000} : \sqrt{75,000}; \text{ or, } q_1 = 20,785 \text{ cu. ft. Ans.}$$

23. If in an airway 1,200 feet long the air has a velocity of 400 feet per minute under a pressure of 3 pounds per square foot, what must the pressure be to maintain the same velocity if the length of airway is increased to 1,800 feet?

SOLUTION.—Applying law (5),

$$3 : p_1 :: 1,200 : 1,800 ; \text{ or, } p_1 = 4.5 \text{ lb. per square foot. Ans.}$$

24. If the air passes with a velocity of 600 feet per minute through an airway whose sectional area is 64 square feet, what will the velocity be if the area is decreased to 48 square feet, the pressure remaining constant ?

SOLUTION.—Applying law (12),

$$600 : v_1 :: \sqrt{64} : \sqrt{48} ; \text{ or, } v_1 = 519.6 \text{ ft. per minute. Ans.}$$

25. Two circular airways of the same length have diameters of 3 feet and 4 feet, respectively ; if a pressure of 5 pounds per square foot will force the air through the 4-foot airway, what pressure is required to pass the same quantity through the 3-foot airway ?

SOLUTION.—Law (22) must be applied to this case, and since a circle has no sides, the perimeter or diameter may be used in the proportion. Hence,  $5 : p_1 :: 3^5 : 4^5$  ; or,  $5 : p_1 :: 243 : 1,024$  ; whence,  $p_1 = 21.07$  lb. per square foot. Ans.

26. If 10,000 cubic feet of air pass per minute through a circular airway 12 feet in diameter, how many cubic feet per minute will pass through an airway 6 feet in diameter and having the same length, the pressure being the same in both cases ?

SOLUTION.—Applying law (21),

$$10,000 : q_1 :: \sqrt{12^5} : \sqrt{6^5} ; \text{ or, } q_1 = 1,768 \text{ cu. ft. per minute. Ans.}$$

**982. Remarks.**—By aid of the foregoing laws and formulas, the student can calculate any problem relating to the flow of air which does not involve splits or regulators. Many of the formulas would be unnecessary if the student had even a slight knowledge of algebra. For example, formulas **a'**, **f**, **39** and **40** are all derived from formula **38** by simply transposing terms ; and formula **38** is, in turn, derived from formula **37** by substituting for  $P$  its value  $p a$ . If the student has no knowledge of algebra, he should memorize all of the numbered formulas.

**983.** In working examples, the student should proceed as follows: Consider example 11, Art. **981**. First ascertain what is required. In this example we want the water-gauge, the quantity, and the horsepower. The water-gauge is easily obtained, since  $p$ , the pressure per square foot, is given. To find  $q$ , the quantity, we look in Table 24, and find that there are five formulas by which the value of  $q$  may be obtained.

We can not use **p** or **51**, because we do not know the values of  $u$  or  $H$ ; but we can use any one of the three remaining formulas, for we know, or can readily find, the values of  $a$ ,  $v$ ,  $s$ , and  $k$ , which are given in the example. Such being the case, we naturally use the one which will require the least amount of labor, and that is, evidently, formula **43**. To find  $H$ , the horsepower, we refer again to Table 24, and find four different forms of formula **48**, any one of which may be used, since  $u$ , in the first form, may be found by means of formula **47**. We again use the easiest one, which is the one used in the solution, since the values of  $p$  and  $q$  are both known.

Examples solved like Example 18, Art. **981**, are worked in a similar manner. First find what is wanted (in this case  $H$ ), and what is given (in this case  $H$ ,  $q$ , and  $q_1$ ); then look in the list of laws (Art. **980**) for one giving the relation between the horsepower and the quantity (in this case law **15**).

#### INFLUENCE OF A STACK UPON THE MOTIVE COLUMN.

**984.** The erection of a stack over the upcast shaft has the same effect as increasing the effective depth of the shaft, or, in other words, increasing the height of the motive column. The quantity of air in circulation is thereby increased according to the proportion

$$\sqrt{D} : \sqrt{D+h} :: q_1 : q_2;$$

or, 
$$q_2 = q_1 \sqrt{\frac{D+h}{D}},$$

and 
$$q_1 = q_2 \sqrt{\frac{D}{D+h}} \quad (55_1.)$$

in which  $q_1$  = quantity of air in circulation per minute without the stack;

$q_2$  = quantity of air in circulation per minute after the stack is erected;

$D$  = depth of shaft;

$h$  = height of stack.



**EXAMPLE.**—The depth of a certain furnace shaft is 225 feet, the height of the stack over it is 31 feet; to what will a circulation of 24,000 cu. ft. per minute be reduced if the stack is blown down?

**SOLUTION.**—Applying formula 551,

$$q_1 = 24,000 \sqrt{\frac{225}{225 + 31}} = 24,000 \times \frac{15}{16} = 22,500 \text{ cu. ft. per minute. Ans.}$$

### SPLITTING THE AIR.

**985.** By splitting is here meant dividing the ventilating current into two or more currents, each of which circulates in a separate district of the mine; any currents thus formed is commonly called a **split**.

The benefits to be derived from the splitting of the air-current may be stated as follows:

(a) A larger volume of air may be circulated in a mine with the same power.

(b) Fresher and purer air is supplied at the working face in each district, and the velocity of the current traversing the face is moderate.

(c) Each district has its own circulation, which is readily controlled, and may be increased or decreased as occasion may require.

(d) An explosion or a windy shot occurring in one district is not as often transmitted throughout the mine.

The student will realize at once the importance of a thorough knowledge of this portion of the subject. For example, the means employed for the ventilation of a new mine, whether fan or furnace, are often found after a year or two of rapid development to be inadequate to the present need. This difficulty is easily overcome in most cases by

judicious splitting of the ventilating current.

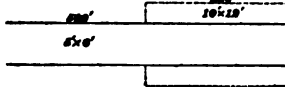

FIG. 140.

**986.** In order to study the effects of splitting, consider Fig. 140, which represents an airway 1,000 feet long and 5' × 6' in section. Suppose that 12,000 cubic feet per minute are

passing; then, the velocity is  $\frac{12,000}{5 \times 6} = 400$  feet per minute. The rubbing surface is  $(2 \times 5 + 2 \times 6) \times 1,000 = 22,000$  square feet. Hence, by formula 53,  $u = k s v^3 = .0000000217 \times 22,000 \times 400^3 = 30,553.6$  foot-pounds per minute.

Suppose that midway in its length the airway were to be enlarged, as shown by the dotted lines. The velocity in the large airway must now be greatly reduced, since the quantity discharged is the same as before (assuming that the velocity in the small airway remains 400 feet per minute), and the area of the section being larger, the velocity must be less.

By formula 44, the velocity  $= v = \frac{q}{a} = \frac{12,000}{10 \times 12} = 100$  feet per minute. Now, since the rubbing surface of the small airway is just one-half of what it was before, the power required to force the air through it must evidently be one-half, or  $\frac{30,553.6}{2} = 15,276.8$  foot-pounds per minute. The power

required to force the air through the large airway is (see formula 47)  $u = p q = \frac{k s v^3}{a} \times q =$

$$\frac{.0000000217 \times [(2 \times 10 + 2 \times 12) \times 500] \times 100^3}{10 \times 12} \times 12,000 =$$

477.4 ft.-lb. per minute. Hence, the total power  $= 15,276.8 + 477.4 = 15,754.2$  foot-pounds per minute, while in the former case, 30,553.6 foot-pounds per minute were required. This shows that by enlarging the airway, as shown, the same quantity may be passed with a greatly reduced power, or the quantity may be greatly increased with the same power. The quantity that will pass with the same power is easily found by applying law 15. Thus,

$$15,754.2 : 30,553.6 :: 12,000^3 : q_1^3,$$

$$\text{or} \quad q_1 = 14,965 \text{ cu. ft. per min.}$$

Since, before the enlargement, 12,000 cubic feet were discharged, the gain is  $14,965 - 12,000 = 2,965$  cubic feet per minute, or very nearly 25 per cent.

The above calculation shows that in the case just considered the small airway requires  $\frac{15,276.8}{477.4} = 32$  times as much power as the large one, and that if the small airway be decreased in length, this proportion of 32 to 1 will also decrease. Consequently, in cases like the above, it is best to decrease the length of the small airway as much as possible.

**986.** To split the air-current to advantage requires that the *main* airways, both *intake* and *return*, as also the *down-cast* and *upcast* shafts, shall be of ample sectional area. A wise provision should always be made in this respect, since the entire circulation for all the districts must pass through these main airways. Were it not for this crowding of all the circulation into these main conduits for a short distance, the volume of air produced, when the power remains constant, would be always proportional to the number of primary splits. That is to say, we would obtain double the quantity of air with the same power when we double the number of splits, and likewise for any number of primary splits the quantity would be in proportion to the number of splits. But since all the circulation must be crowded through the main airway at a high velocity till the point is reached where the first split is made, we do not obtain an increase of quantity in the same proportion as we increase the number of splits. The increase in quantity will always be in a less ratio. To make this clear, let us take for illustration some practical examples.

**EXAMPLE 1.**—Find the power (foot-pounds per minute) that will circulate 24,000 cubic feet of air per minute in a mine, under the following conditions: the air to be circulated in one continuous current through an airway 16,000 feet long, including the return, the size of all the airways to be  $6' \times 10'$  throughout the mine.

**SOLUTION.**—Using formula  $u'$ ,

$$u = \frac{k s q^3}{a^3} = \frac{.000000217 \times 2 (6 + 10) \times 16,000 \times 24,000^3}{(6 \times 10)^3} = 711,066 \text{ ft.-lb. per minute. Ans.}$$

**EXAMPLE 2.**—Find the power (foot-pounds per minute) that will circulate 24,000 cubic feet of air through a mine under the following conditions: Referring to Fig. 141, the air is divided at the foot of the downcast *a* into four splits, each 3,600 feet long and  $6 \times 10$  feet in section, and finally united at the foot of the upcast *u*. The shafts are each 800 feet deep and are also  $6' \times 10'$  in section. It will be noticed that the size and total length of airways are the same as in Example 1.

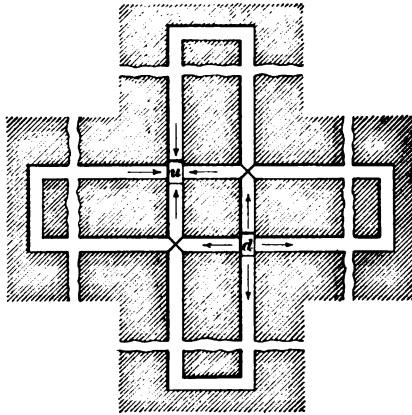

FIG. 141.

**SOLUTION.**—It is evident that the total power is equal to the sum of the powers absorbed in the different passages. Using formula  $u'$ , the power absorbed in the two shafts is

$$u = \frac{k s q^3}{a^3} = \frac{.0000000217 \times 2 (6 + 10) \times 2 \times 800 \times 24,000^3}{(6 \times 10)^3} = 71,107 \text{ ft.-lb.}$$

per minute, nearly.

Using the same formula and noting that, since the splits are equal, the quantity of air passing through each will be  $\frac{24,000}{4} = 6,000$  cu. ft., the power absorbed by the splits is

$$u = \frac{k s q^3}{a^3} = \frac{.0000000217 \times 2 (6 + 10) \times 4 \times 3,600 \times 6,000^3}{(6 \times 10)^3} = 10,000 \text{ foot-}$$

pounds per minute, nearly.

The total power is therefore  $71,107 + 10,000 = 81,107$  ft.-lb. per min.

Ans.

This result shows that in this case it required, after splitting, but 11.4 per cent. of the power originally required to pass the same quantity of air through the mine.

**EXAMPLE 3.**—Determine the quantity of air that the power used in Example 1 will pass through a mine having the same conditions as those in Example 2.

**SOLUTION.**—Applying law 15,

$$81,107 : 711,066 = 24,000^3 : q_1^3;$$

$$\text{or, } q_1 = \sqrt[3]{\frac{711,066}{81,107}} \times 24,000 = 49,488 \text{ cubic feet per minute, nearly. Ans.}$$

Comparing the result in Example 3 with the quantity circulated in Example 1, it will be seen that, by splitting as in

**Example 2,** over twice as much air is passed through the mine with the same power.

**986.** In all cases of equal splitting at a distant point in the mine, the increased quantity of air put in circulation by the original power may be found by the formula

$$q_1 = \frac{nq}{\sqrt[3]{1 + \frac{l}{L}(n^3 - 1)}} \quad (55_*)$$

in which  $q$  = original quantity;

$q_1$  = increased quantity;

$n$  = number of splits;

$l$  = length of airway from beginning of intake to point of splitting;

$L$  = total length of original airway.

**EXAMPLE.**—In a drift mine 3,500 feet long, 50,000 cubic feet of air per minute are circulated in a continuous current. What quantity will the same power circulate if three splits are made at a point on the intake 1,000 feet from the drift mouth?

**SOLUTION.**—Applying formula 55\_\*,

$$q_1 = \frac{nq}{\sqrt[3]{1 + \frac{l}{L}(n^3 - 1)}} = \frac{3 \times 50,000}{\sqrt[3]{1 + \frac{1,000}{3,500}(3^3 - 1)}} = 73,706 \text{ cu. ft. Ans.}$$

**986.** If the method of ventilating a mine be changed from a continuous current to a number of splits, the total quantity of air that the original power will pass through the splits can be found by the following formula, in which  $q_t$  = total quantity passing through the splits;  $q$  = quantity passing through original airway;  $a_t$  = total area of splits;  $a$  = area of original airway;  $s_t$  = total rubbing surface of splits; and  $s$  = rubbing surface of original airway. If desired, the quantities passing through the separate splits can then be found by the method used in Art. 992.

$$q_t = \frac{a_t q}{a} \sqrt[3]{\frac{s}{s_t}} \quad (55_*)$$

**EXAMPLE.**—If a certain power circulates 80,000 cu. ft. of air per min. through an airway 9' × 6' in section and 9,400 ft. long, what quantity will

it pass through the following splits which are substituted for the original airway? Split *A*, 9' × 6' in section and 5,400 ft. long; split *B*, 8' × 5 in section and 3,600 ft. long; split *C*, 6' × 6' in section and 3,000 ft. long.

SOLUTION.—Using formula 55a,

$$q_t = \frac{(9 \times 6 + 8 \times 5 + 6 \times 6) \times 80,000}{9 \times 6} \times \sqrt{\frac{2(9 + 6) \times 9,400}{2(9 + 6) \times 5,400 + 2(8 + 5) \times 3,600 + 2(6 + 6) \times 3,000}} = 183,206, \text{ say, } 183,200 \text{ cu. ft. per min. Ans.}$$

**987.** To realize the benefits which may be obtained by splitting, consider Fig. 142, which is a simple, practicable case. *D* is the downcast and *U* the upcast shaft. Imagine the airways *AI* and *KJ* to be removed. Then the air will flow down the shaft *D* and along the airway *DBCH EFGU*

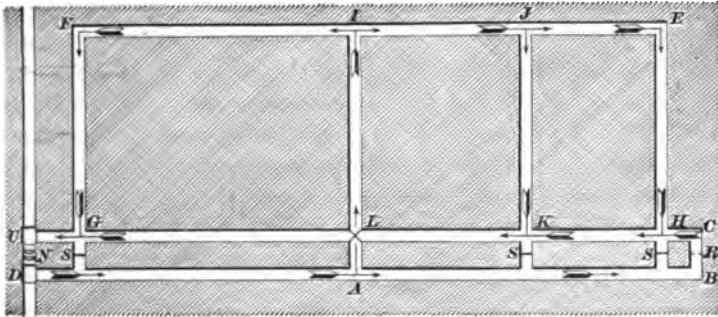

FIG. 142.

and up the upcast shaft. Suppose that the distance *DB* were 3,000 feet and the distance *AI*, 1,500 feet. The total distance traveled by the air from the foot of the downcast to the foot of the upcast would then be about 9,000 feet. Before the air reached *F* it would be foul and heavy with mine gases, carbonic acid gas, and other impurities, and it would be nearly impossible to work there. By splitting the air, this condition of things is remedied to a great extent. Thus, by splitting at *A*, fresh air from *D* passes along *AI* and is again split at *I*; a part going to *F* and another part

towards *E*. At *J*, there is another split, a certain proportion going to *K* and the remainder to *E*, and from *E* to *H*. *DB* is called the **main airway** and *UC* the **main return**. After splitting at *A*, that portion of the air which does not pass along *LI* continues along the main airway to the point *C*, where it passes into the main return and flows directly to the upcast at *U*. In order to accomplish the result described, a **bridge** is necessary at *L* to keep the fresh air from mingling with the return air; stoppings must be introduced at *S*, *S*, *S*, and a regulator must be placed at *R*. A **regulator** is an arrangement by which the sectional area of an airway can be reduced; it is virtually an increase of resistance to the movement of the flowing air. Only the reasons for using it will be mentioned here, as it will be described fully later.

Air or any other fluid will also travel along the path of least resistance, and always tends towards equilibrium. Now, suppose that it requires a greater power to force a certain quantity of air along the combined paths *AIFGU*, *IJKL*, and *JEHK*, than along the path *ABCU*; then more air will go towards *B* than towards *I*. But it is the exact opposite of this that is required; in other words, it is necessary that more air should flow towards *I* than towards *B*. By interposing a sufficiently great resistance at *R*, the greater volume of air will be forced to flow towards *I*.

This, then, is the principal object of splitting—*to supply the workings with fresh air*. Splitting must not, however, be carried to too great an extent, since every split reduces the velocity very rapidly, and the current will soon become too feeble to sweep out the noxious gases.

**988.** The first split, or, in fact, any split in the main airway, is variously called a **main split**, a **primary split**, or a **split of the first degree**, as at *A*. The second split, as at *I*, is called a **secondary split**, or a **split of the second degree**. The split at *J* is called a **tertiary split**, or a **split of the third degree**. It should be noted that

the degree of the split does not refer to the number of splits, though it happens so in the above case. The air coming along the main airway is divided at *A*, a part going to *J*; this part is again divided, a part going to *J*, and this last part is once more divided. Where two returns unite, as at *G*, *K*, and *H*, they are called **junctions**.

**989. Unequal Splitting.**—It was stated, when describing the necessity and action of a regulator, that the air always tended towards equilibrium. By this was meant that when the air had adjusted itself to the conditions governing its flow, a certain proportion would go one way and another proportion the other way, and no matter what the quantity passing might be, these proportions would always be preserved, provided there were no alterations in the lengths or sectional areas of the airways. To take a very simple illustration, suppose that in Fig. 143, *D* is the downcast and *U* the upcast.

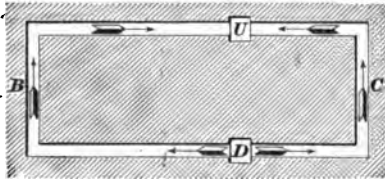

FIG. 143.

Then, it is evident, from what has been previously stated, that more air will flow through *D C U* than through *D B U*, since *D C U* is shorter, has less rubbing surface, and, consequently, offers less resistance than *D B U*, the same sectional area and perimeter being assumed for both airways. In this case the air is split at *D*, and whenever there is a split in which one airway receives a greater quantity than the other, it is called an **unequal split**.

**990.** In every case of splitting, whether equal or unequal, *the pressure per square foot is the same in both splits.*

In order to explain this apparently inconsistent statement, one of the most important pertaining to the science of mine ventilation, it is necessary to digress for a time from the main subject.

In Fig. 144, let *A B D C* represent a vessel filled with a



fluid, say water, for convenience, having two columns,  $A B$  and  $C D$ , fitted with pistons, as shown, and communicating by the passageway  $B D$ . Suppose that the area of the smaller piston be 1 square foot and of the larger, 5 square feet; then, in order that there shall be equilibrium, that is, in order that the level of the water in both vessels shall be the same,

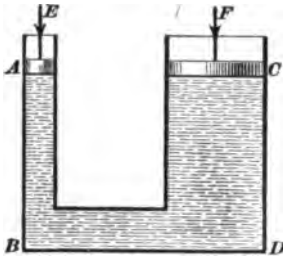

FIG. 144.

the pressure per square foot on the piston at  $A$  must be equal to the pressure per square foot on the piston at  $C$ . This follows from **Pascal's law**, which states that *in the case of any fluid (gas or liquid), pressure is transmitted undiminished in all directions, whether downwards, upwards, or sideways*. If a force  $E$  of 5 pounds acts upon the piston  $A$ , a force of 5 pounds per square foot (since the area of  $A$  is 1 square foot) will be transmitted *upwards* against the piston  $C$ . Hence, to prevent  $C$  from moving upwards, a downward force  $F$  of  $5 \times 5 = 25$  pounds must be applied to  $C$ . Moreover, it matters not what the areas of the pistons  $A$  and  $C$  are, the pressure per square foot must be the same on both pistons in order that they shall not move.

**991.** The same result obtains in a case like Fig. 145. Here a force  $E$  acts upon the piston  $A$ , and the pressure per square foot on  $A$  is transmitted with equal intensity to all parts of the surfaces touched by the water. This is exactly analogous to a split in which  $A G$  represents the down-cast shaft and  $C G$  and  $G H$  the splits.

As stated above, Pascal's law is true for either liquids or gases. It has to be modified somewhat when applying it to the case of air in motion, since it is then true only when the motion is uniform. But to secure uniformity

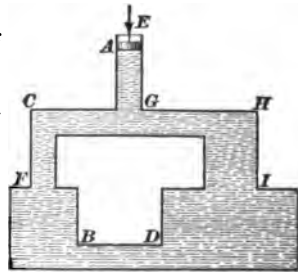

FIG. 145.

of motion, the resistance must be uniform, a condition which is practically always the case in mine ventilation. Since the airway up to the split requires a certain pressure to overcome the resistance it offers, this pressure should be deducted from the reading of the water-gauge, and the remainder treated as the pressure in each split.

**992.** Resuming now the subject of unequal splitting, consider Fig. 146. Let  $D$  and  $U$  represent the downcast and upcast shafts, respectively.

Four unequal splits are here represented. The upcast and downcast shafts are  $15' \times 10'$  and 600 feet deep; the airway  $D A U$  is  $5' \times 8'$  and 2,000 feet long; the airway  $D B U$  is  $6' \times 9'$  and 1,500 feet long; the airway  $D C U$  is  $7' \times 9'$  and 3,000 feet long, and the airway  $D E U$  is  $8' \times 10'$  and 1,800 feet long. Suppose that the velocity of the air in the shafts is 700 feet per minute and that it is required to find the pressure per square foot, the quantity passed by each split, and the horsepower required to circulate the air.

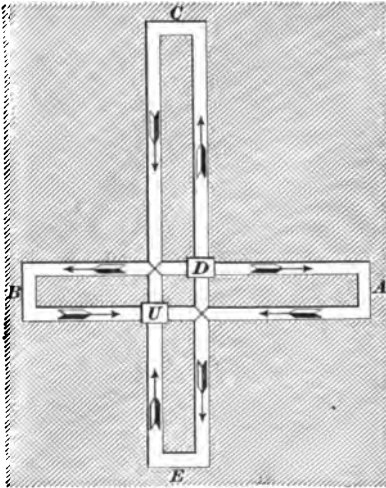

FIG. 146.

It is first necessary to find the total quantity of air passing through the shaft. This evidently equals, using formula 43,  $q = a v = 15 \times 10 \times 700 = 105,000$  cubic feet per minute.

The pressure per square foot required to pass this through the two shafts is

$$p = 2 \times \frac{k s v^2}{a} =$$

$$\frac{2 \times .0000000217 \times (2 \times 15 + 2 \times 10) \times 600 \times 700^2}{15 \times 10} =$$

4.2532 lb. per square foot.

Before the pressure per square foot for the splits can be found, it is necessary to calculate the quantities passing through each split. In order not to confuse the student, only the steps necessary for the calculation will here be given.

Let  $q_1, a_1$  and  $s_1, q_2, a_2$  and  $s_2, q_3, a_3$  and  $s_3, q_4, a_4$  and  $s_4$  represent the quantity, sectional area, and rubbing surface in the splits  $DAU, DBU, DCU,$  and  $DEU,$  respectively. Then calculate the following expressions:

$$\sqrt{\frac{a_1^3}{s_1}} = \sqrt{\frac{40^3}{52,000}} = 1.1094, \text{ since } a_1 = 5 \times 8 = 40 \text{ and } s_1 = (2 \times 5 + 2 \times 8) \times 2,000 = 52,000.$$

$$\sqrt{\frac{a_2^3}{s_2}} = \sqrt{\frac{54^3}{45,000}} = 1.8706, \text{ since } a_2 = 6 \times 9 = 54 \text{ and } s_2 = (2 \times 6 + 2 \times 9) \times 1,500 = 45,000.$$

$$\sqrt{\frac{a_3^3}{s_3}} = \sqrt{\frac{63^3}{96,000}} = 1.6139, \text{ since } a_3 = 7 \times 9 = 63 \text{ and } s_3 = (2 \times 7 + 2 \times 9) \times 3,000 = 96,000.$$

$$\sqrt{\frac{a_4^3}{s_4}} = \sqrt{\frac{80^3}{64,800}} = 2.8109, \text{ since } a_4 = 8 \times 10 = 80 \text{ and } s_4 = (2 \times 8 + 2 \times 10) \times 1,800 = 64,800.$$

$$\text{sum} = 7.4048$$

Dividing each of the above results by their sum, and multiplying by the total quantity passing through the shaft, 105,000 cubic feet per minute, the results thus obtained will be the quantities of air passing through the different splits.

Thus,

$$q_1 = \frac{1.1094}{7.4048} \times 105,000 = 15,731 \text{ cu. ft. per minute in } DAU.$$

$$q_2 = \frac{1.8706}{7.4048} \times 105,000 = 26,525 \text{ cu. ft. per minute in } DBU.$$

$$q_3 = \frac{1.6139}{7.4048} \times 105,000 = 22,885 \text{ cu. ft. per minute in } DCU.$$

$$q_4 = \frac{2.8109}{7.4048} \times 105,000 = 39,859 \text{ cu. ft. per minute in } DEU.$$

$$\text{sum} = 105,000 \text{ cu. ft. per minute.}$$

Now, find the velocities by applying formula 44.

$$v_1 = \frac{15,731}{40} = 393.3 \text{ ft. per minute in } DAU.$$

$$v_2 = \frac{26,525}{54} = 491.2 \text{ ft. per minute in } DBU.$$

$$v_1 = \frac{22,885}{63} = 363.3 \text{ ft. per minute in } DCU.$$

$$v_2 = \frac{39,859}{80} = 498.2 \text{ ft. per minute in } DEU.$$

Since the pressure is the same for each split, it is necessary to find it for one only. Hence,

$$p_1 = \frac{k s_1 v_1^2}{a_1} = \frac{.0000000217 \times 52,000 \times 393.3^2}{40} = 4.3637 \text{ lb. per square foot.}$$

The total ventilating pressure per square foot is  $4.2532 + 4.3637 = 8.6169$ , say 8.62, pounds per square foot.

By formula 48, the horsepower =

$$H = \frac{pq}{33,000} = \frac{8.62 \times 105,000}{33,000} = 27.43 \text{ horsepower, nearly.}$$

Examples similar to the above may be solved in the same way.

### REGULATORS.

**993.** A regulator is shown in Fig. 147, and consists principally, as will be noticed, of a sliding shutter moving

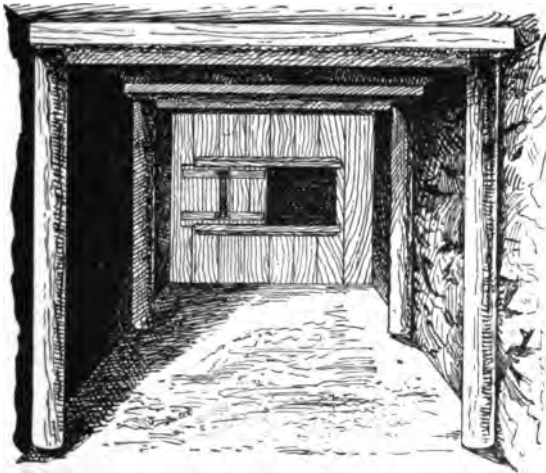

FIG. 147.

in grooves. By means of this shutter, the width of the

opening may be adjusted so as to cause a greater or less quantity of air to pass through the airway.

In order to clearly understand the effect produced by a regulator, it is necessary to consider once more what determines the ventilating pressure per square foot. By formula **38**,  $p = \frac{k s v^2}{a}$ , and since the value of neither  $k$  nor  $a$  changes for the same airway through the introduction of a regulator, they may be neglected in *comparing* the results obtained by changing  $s$  and  $v$ . Now, if  $p$  represents the ventilating pressure per square foot in the splits, it should be evident from what has been stated before that the mere introduction of a regulator in any split will not change the value of  $p$  in that split, provided the quantity of air passing through the other splits be not increased, since, if  $p$  were increased for one split, it would have to be increased a like amount also for the other splits, in order to restore the equilibrium according to Pascal's law, and this would increase the quantity of air in the other splits. But the introduction of a regulator in any split reduces the quantity of air passing through that split, and, as a consequence, reduces the velocity. Hence, if  $p$  is to remain the same,  $s$  must be increased, or some device must be used which will produce the same effect as increasing  $s$ ; this device is the regulator itself. The conclusion is now evident: *the regulator is equivalent to lengthening the airway.*

**994.** Since, by formula **47**, the power  $= u = p q$ , and  $p$  remains the same after the regulator has been placed in the split, while  $q$  is reduced in consequence of the reduction of the quantity of air in the split containing the regulator, it is evident that less power will be required than before the regulator was introduced. Hence, if the power remains the same, both the velocity and the pressure will be increased throughout the mine, and the other splits will pass more air than before and *at a higher pressure*. This last is a very important feature in the case of gaseous mines, and will now be explained.

**995.** In Fig. 148, let  $D$  be the downcast and  $U$  the up-cast shaft. The air is split at  $A$ , as shown. Suppose that the shafts are  $8' \times 14'$  and 500 feet deep, and that all of the airways are  $9' \times 12'$  and of the following lengths:  $DA = 1,320$  feet;  $ABCU = 2,640$  feet =  $\frac{1}{2}$  mile, and  $AEU = 10,560$  feet = 2 miles.

Suppose that the water-gauge in one of the return airways near  $U$  indicates, say, 1.53 inches, then the quantity of air passing in each split may readily be found. Since  $p = 5.2 W$ ,  $p = 5.2 \times 1.53 = 7.956$  lb. per square foot. A certain amount of this is absorbed in overcoming the resistance of  $DA$ , while the remainder urges the air through

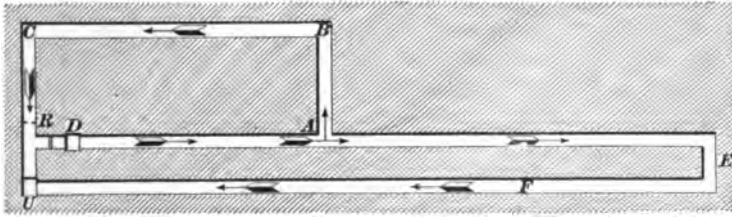

FIG. 148.

$ABCU$  and  $AEU$ . In order to find what proportion of the pressure is expended in  $DA$ , and what proportion in the splits, it is first necessary to find the relative velocities in the two splits. Representing by  $v_1$  and  $v_2$  the velocities of air in  $ABCU$  and  $AEU$ , respectively, and applying law (13),

$$v_1 : v_2 :: \sqrt{2} : \sqrt{5}; \text{ or, } v_1 = v_2 \times \frac{\sqrt{2}}{\sqrt{5}} = v_2 \times \sqrt{\frac{2}{5}} = 2 v_2.$$

Now, representing by  $p_1$  the pressure in the splits; by  $p$ , the pressure required to pass the air through the airway  $DA$ , and by  $v$ , the velocity in  $DA$ , we have, by applying formula 38,

$$p = \frac{ksv^2}{a}, \text{ and } p_1 = \frac{ks_1v_1^2}{a};$$

in other words, 
$$p : p_1 :: \frac{ksv^2}{a} : \frac{ks_1v_1^2}{a};$$

or, 
$$p : p_1 :: sv^2 : s_1v_1^2.$$

**996.** Since both splits have the same sectional area, and the velocity in the short one is twice that in the long one, it is evident that the short split passes twice the quantity that the long one does, or the short split passes two-thirds and the long split one-third of the total quantity coming along the airway  $DA$ . If  $v$  is the velocity in  $DA$ , it is evident (since the sectional areas are equal) that  $v_1 = \frac{2}{3}v$ , and  $v_2 = \frac{1}{3}v$ . Then, since  $p : p_1 :: s v^2 : s_1 v_1^2$ ,  $p : p_1 :: s v^2 : s_1 (\frac{2}{3}v)^2$ ; or, substituting the values of  $s$  and  $s_1$ ,  $p : p_1 :: (2 \times 9 + 2 \times 12) \times 1,320 \times v^2 : (2 \times 9 + 2 \times 12) \times 2,640 \times \frac{4}{9} v^2$ ; whence,  $p = 1\frac{1}{2} p_1$ .

Now, since  $p + p_1 = 7.956$ ,  $1\frac{1}{2} p_1 + p_1 = 7.956$ , or  $2\frac{1}{2} p_1 = 7.956$ , and  $p_1 = 3.744$  lb. per square foot = pressure for the splits. Also,  $p = 1\frac{1}{2} p_1 = 1\frac{1}{2} \times 3.744 = 4.212$  lb. per square foot = pressure for  $DA$ .

Applying now formula **40**, the velocity in  $A E U = v_s =$   

$$\sqrt{\frac{p_1 a}{k s}} = \sqrt{\frac{3.744 \times 9 \times 12}{.0000000217 \times (2 \times 9 + 2 \times 12 \times 2 \times 5,280)}} =$$
 205 ft. per minute, very nearly.

Hence,  $v_1 = 2 v_s = 2 \times 205 = 410$  ft. per minute, and  $v = 3 v_s = 615$  ft. per minute. The quantity passing through  $DA = q = a v = 9 \times 12 \times 615 = 66,420$  cu. ft. per minute. The quantity passing through the short split is  $66,420 \times \frac{2}{3} = 44,280$  cu. ft. per minute, and through the long split,  $66,420 \times \frac{1}{3} = 22,140$  cu. ft. per minute.

Applying formula **44** to find the velocity in the shaft,

$$v_s = \frac{q}{a_s} = \frac{66,420}{8 \times 14} = 593.04 \text{ ft. per minute,}$$

letting  $v_s$ ,  $a_s$ , and  $p_s$  be the velocity, area, and pressure for the shaft, respectively. Remembering that there are two shafts, the pressure required to drive the air through them is

$$p_s = \frac{k s_s v_s^2}{a_s} =$$

$$\frac{.0000000217 \times (2 \times 8 + 2 \times 14 \times 500 \times 2) \times 593.04^2}{8 \times 14} =$$
 2.998 lb. per square foot.

Consequently, the total pressure per square foot required to move the air is  $7.956 + 2.998 = 10.954$  lb. per square foot; the power  $= p q = 10.954 \times 66,420 = 727,565$  ft. lb. per minute, and the horsepower  $= \frac{727,565}{33,000} = 22.05$  H. P.

**997.** It will be noticed that the velocity of the air in the long split  $A E U$  is very low, being but 205 feet per minute, and should the grade be an upward one, or even should there be no grade at all, it will be very difficult, if not impossible, to drive out any mine gas that may collect at  $E$ . To increase the power sufficiently to accomplish this would be a *very* costly method; but by putting a regulator at  $R$ , the quantity of air going through the short split may be so much reduced that with the same power a sufficient quantity of air may be driven through the long split as to dislodge the mine gases at  $E$ . If necessary, all of the air going through the short split may be shut off and the whole ventilative power of the mine applied to the long split. This is the most important result achieved by the regulator.

**998.** Suppose, however, that it was desired to ascertain the area of the regulator opening, in order to have the short split pass the same quantity of air that the long split passes. Taking the velocity in the long split as 205 feet per minute, that in the short split will then be 205 feet also, and the pressure required may be found by means of law (4) as follows:  $p : p_1 :: v^2 : v_1^2$ , or  $3.744 : p_1 :: 410^2 : 205^2$ ; whence,  $p_1 = .936$  lb. per square foot = pressure required to send the air through the split  $A B C U$  at a speed of 205 feet per minute. But the actual pressure is 3.744; hence, the regulator must offer a resistance of  $3.744 - .936 = 2.808$  lb. per square foot. Assuming the regulator to have been adjusted properly, a water-gauge placed in it will show a difference of pressure between the two sides of the regulator of 2.808 lb. per square foot  $= \frac{2.808}{5.2} = .54$  in. of water.



The area of the opening may now be calculated by aid of the following formula:

$$A = \frac{.0004q}{\sqrt{W}}, \quad (56.)$$

in which  $A$  = area of opening in square feet;

$q$  = quantity of air in cubic feet per minute which it is desired to pass through the opening;

$W$  = difference of pressure in inches of water on the two sides of the regulator.

Substituting in formula **56** the values previously found,

$$A = \frac{.0004 \times 22,140}{\sqrt{.54}} = 12.05 \text{ sq. ft.}$$

The total quantity of air now going through the mine is  $22,140 + 22,140 = 44,280$  cu. ft. per minute, or two-thirds of the quantity which went through before the regulator was introduced; and since the pressure per square foot remains the same as before, the horsepower required is but two-thirds of that previously required. Hence, if the horsepower be increased to its former value, the quantity will also be increased, but not to the same amount as before, since any increase in the quantity increases the velocity, which necessarily increases the frictional resistances—in other words, the ventilating pressure. The calculation will not be gone through with here to show just how much the ventilating pressure will be increased, as it is of no particular value to the student, and might tend to confuse him. He should, however, be able to see that the ventilating pressure and the velocity are both increased by the introduction of a regulator, and this is what is required to drive out the gas.

**999.** One more advantage obtained by splitting the air will now be noticed, and it is one of great value.

Fig. 149 represents a system of splits in which  $FA$  represents the fresh, or main, airway, and  $RA$  the return airway. The student will notice that when two arrow-heads are joined to one tail, there is a split, and when two tails

are joined to one head there is a junction. Suppose that in the left-hand half of the mine represented in the figure, gas were to accumulate in one of the farther workings, and the air had not sufficient pressure to drive it out. By shutting off the air in the other half of the mine, the entire power of

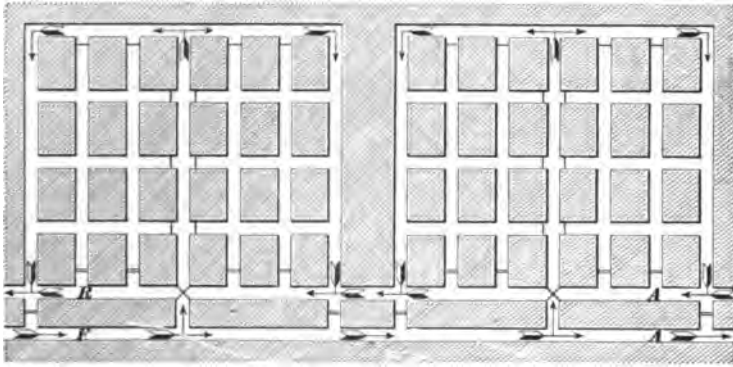

FIG. 149.

the ventilation may be employed to increase the pressure of the air in the left-hand half and drive out the gas. This is termed "sweeping out the mine," and is one of the greatest advantages obtained by splitting.

### THE FIFTH ROOT.

**1000.** By aid of Table 25 the fifth root of any number may be found correctly to four figures. The arithmetical method of extracting the fifth root is very long and laborious. Since four figures are sufficient for all practical purposes in problems pertaining to mine ventilation, it was thought better to give the table than to give the rule generally used. The method of using the table will be exhibited by examples.

**EXAMPLE.**—Extract the fifth root of 1,264.782.

**SOLUTION.**—Only the first five figures of the number are required when using the table. When the sixth figure is 5, or greater, increase the fifth figure by 1, and omit the remaining figures. Doing so, the question becomes  $\sqrt[5]{1,264.8} = ?$  Looking in column 4 of the table for

the nearest number *smaller* than the given number, it is found to be 1,158.6, opposite the number 4.1 in column 1, and 4.1 are the first two figures of the root. To find two more figures of the root, proceed as follows:  $1,264.8 - 1,158.6 = 106.2$ . Divide this remainder by the number in column 3 in the same row as the two numbers previously found, in this case 141.3, and obtain two figures of the quotient. If the second figure is greater than 5, increase the first figure by 1 and neglect the second figure. Should the second figure be a 5, obtain three figures of the quotient, and if the *third* figure is 5, or greater, increase the first figure by 1, and neglect the other two. Thus,  $106.2 \div 141.3 = .751$ , and the number to be used is .7, since the third figure is less than 5. It is necessary to obtain three figures of this quotient only when the *second figure is a 5*. Now, multiply this quotient, .7 in this case, by the number in column 2 and in the same row as the three previous numbers found in the table, and add the result to the number found in column 3. Thus,  $6.89 \times .7 = 4.823$ , and  $141.3 + 4.823 = 146.123$ . Finally, divide the difference found above ( $106.2$ ) by  $146.123$ ; the result will be the next two figures of the root. Thus,  $106.2 \div 146.123 = .727$ , or .73. Hence, the entire root to four figures is 4.173. Ans.

EXAMPLE.—Find the fifth root of 45,261.

SOLUTION.—Only the numerical work is given; the student should read the explanation given above in connection with the work.  $45,261 - 44,371 = 890$ .  $890 \div 2,610 = .34$ , or .3.  $61.4 \times .3 = 18.42$ .  $2,610 + 18.42 = 2,628.42$ .  $890 \div 2,628.42 = .338$ , say .34. Hence,  $\sqrt[5]{45,261} = 8.534$ . Ans.

If the number is wholly decimal, take the first five figures to the right of the decimal point (annexing ciphers if necessary to make five figures) and treat the number as if it were a whole number with five figures.

EXAMPLE.— $\sqrt[4]{.664} = ?$

SOLUTION.—Annex two ciphers to make the necessary five figures,  $\sqrt[4]{.664} = \sqrt[4]{.66400}$ . Whence,  $66,400 - 65,908 = 492$ .  $492 \div 3,582 = .13$ .  $77.9 \times .1 = 7.79$ .  $3,582 + 7.79 = 3,589.79$ .  $492 \div 3,589.79 = .137$ , or .14. Hence,  $\sqrt[4]{.664} = .9214$ . Ans.

EXAMPLE.— $\sqrt[4]{42,675,830} = ?$

SOLUTION.—Begin at units place and point off the number into periods of **five** figures each. Thus,  $426'75830$ . Retain the first five figures, beginning with the left, the result is  $426'76$ . Regarding the division mark for the present as a decimal point, proceed as in the preceding examples.  $426.76 - 391.35 = 35.41$ .  $35.41 \div 59.3 = .59$ , or .6.  $359 \times .6 = 2.154$ .  $59.3 + 2.154 = 61.454$ .  $35.41 \div 61.454 = .576$ , or .58. Hence, the figures of the root are 3358. The position of the decimal

point may be determined from the statement that *there must be as many figures in the integral part of the root as there are periods in the integral part of the number whose root is to be found*. Since there are two such periods in the above number,  $\sqrt[5]{42,675,830} = 33.58$ .

Ans.

Had the number been 4,267,583,000,000, the number of periods would have been three, and the fifth root,

$$\sqrt[5]{426'75830'00000} = 335.8.$$

It will be a good exercise for the student to prove the following:

$$\sqrt[5]{426,758.3} = 13.37; \quad \sqrt[5]{4,267,583} = 21.19;$$

$$\sqrt[5]{426,758,300} = 53.22, \text{ and } \sqrt[5]{4,267,583,000} = 84.34.$$

**1001.** If it is absolutely necessary for the student to extract the fifth root without the aid of a table, he may do so in the following manner:

$$\sqrt[5]{4,267,583} = ?$$

1. Point off the number into periods, as above directed, obtaining in this case 42'67583.

2. Find a number expressed by one figure whose fifth power is next less than the number expressed by the first period. It will aid the student, in finding the first figure of the root, if he will remember that if the first period contains but one figure, the first figure of the root must be 1; if but two figures, the first figure of the root can not be greater than 2; if but three figures, the first figure of the root is either 2 or 3; if but four figures, the first figure of the root can not be greater than 6, and if the first period contains five figures, the first figure of the root may be 6, 7, 8, or 9. Try 2 for the first figure of the root of the above number and raise it to the fifth power; the result is  $2^5 = 32$ . Since 32 is less than 42, the first figure of the root is 2.

3. To find the second figure, subtract the fifth power of the first figure from the first period and annex the second period to the remainder, or, if there is no second period, bring down five ciphers. Performing the operation on the above number,  $42 - 32 = 10$ ; annexing the second period, the result is 1,067,583.

4. Raise the first figure of the root to the fourth power,

multiply the result by 5, and annex four ciphers. Annex four ciphers to the cube of the first figure, and add the result to the last result. Thus,  $2^3 \times 5 = 80$ ; annexing four ciphers = 800,000.  $2^3$  with four ciphers annexed = 80,000, and  $800,000 + 80,000 = 880,000$ .

5. Divide the result obtained in 3 by the result obtained in 4, and the quotient will *very probably* be the second figure of the root. Thus,  $1,067,583 \div 880,000 = 1 +$ , and the first two figures of the root are 21.

6. Raise the first two figures of the root to the fifth power and subtract the result from the given number whose root is to be found, annexing five ciphers to the given number if it contains but one period. Thus,  $21 \times 21 = 441$ ;  $441 \times 21 = 9,261$ , the cube;  $9,261 \times 21 = 194,481$ , the fourth power, and  $194,481 \times 21 = 4,084,101$ . Hence,  $4,267,583 - 4,084,101 = 183,482$ .

7. Multiply the fourth power of the first two figures (obtained in 6) by 5, and divide the remainder obtained in 6 by the result, and obtain two figures of the quotient. If the second figure of the quotient is greater than 5, increase the first figure by 1 and neglect the second figure; otherwise, use only the first figure. Should the second figure be 5, obtain three figures of the quotient, and if the *third* figure is 5, or greater, increase the first figure by 1. Thus,  $21^4 = 194,481$  (see 6), and  $194,481 \times 5 = 972,405$ ; then,  $183,482 \div 972,405 = .18 +$  or  $.2$ .

8. Multiply the cube of the first two figures of the root (obtained in 6), with a cipher annexed, by the number found in 7, and add the result to 5 times the fourth power (obtained in 7). Thus,  $21^3 = 9,261 = 92,610$ , with a cipher annexed.  $92,610 \times .2 = 18,522$ .  $972,405 + 18,522 = 990,927$ .

9. Divide the remainder obtained in 6 by the result obtained in 8 and carry the quotient to three *decimal* places. If the third figure of the decimal is 5 or greater, increase the second figure by 1. These two figures of the quotient are the third and fourth figures of the root. Thus,  $183,482 \div 990,927 = .185$ , say  $.19$ . Hence the figures of the root

are 2119, and since there are two periods,  $\sqrt[5]{4,267,583} = 21.19$ . Ans.

NOTE.—The method outlined above is exactly what is accomplished by means of Table 25, but the work is very much more laborious. It is, however, the simplest known method of finding the fifth root of numbers.

EXAMPLE.— $\sqrt[5]{9} = ?$

SOLUTION.—2. Since there is but one figure, the first figure of the root is 1.

3.  $9 - 1^5 = 8$ , since  $1^5 = 1$ . Annexing five ciphers gives 800,000.

4.  $1^4 \times 5$  with four ciphers annexed = 50,000;  $1^3$  with four ciphers annexed = 10,000; the sum = 50,000 + 10,000 = 60,000.

5.  $800,000 + 60,000 = 860,000$ . This result is much too high, since the quotient thus obtained (which is the probable second figure of the root) should not exceed 9. Now, remembering that the fifth power of 2 is 32, it is evident that  $\sqrt[5]{9}$  must be considerably less than 1.9, which nearly equals 2. Trying 1.6, the fifth power is  $1.6^5 = 10.48576$ , which is also too high, but quite close; hence, 1.5 is probably the correct number to use, and the first two figures of the root are 15.

6.  $15 \times 15 = 225$ ;  $225 \times 15 = 3,375$ ;  $3,375 \times 15 = 50,625$ , and  $50,625 \times 15 = 759,375$ .  $800,000 - 759,375 = 40,625$ .

7.  $15^4 \times 5 = 50,625 \times 5 = 253,125$ ;  $40,625 + 253,125 = .555$ , or .6.

8.  $15^3$  with a cipher annexed = 33,750;  $33,750 \times .6 = 20,250$ , and  $253,125 + 20,250 = 273,375$ .

9.  $40,625 + 273,375 = .514$ , say .51. Hence,  $\sqrt[5]{9} = 1.551$ . Ans.

TABLE 25.

1	2	3	4	1	2	3	4
1.0	.100	.5000	1.0000	5.6	17.6	491.7	5,507.3
1.1	.133	.7321	1.6105	5.7	18.5	527.8	6,016.9
1.2	.173	1.037	2.4883	5.8	19.5	565.8	6,563.6
1.3	.220	1.428	3.7129	5.9	20.5	605.9	7,149.2
1.4	.274	1.921	5.3782	6.0	21.6	648.0	7,776.0
1.5	.338	2.531	7.5938	6.1	22.7	692.3	8,446.0
1.6	.410	3.277	10.486	6.2	23.8	738.8	9,161.3
1.7	.491	4.176	14.199	6.3	25.0	787.6	9,924.4
1.8	.583	5.249	18.896	6.4	26.2	838.9	10,737
1.9	.686	6.516	24.761	6.5	27.5	892.5	11,603
2.0	.800	8.000	32.000	6.6	28.7	948.7	12,523
2.1	.926	9.724	40.841	6.7	30.1	1,007	13,501
2.2	1.06	11.71	51.536	6.8	31.4	1,069	14,539
2.3	1.22	13.99	64.363	6.9	32.9	1,133	15,640
2.4	1.38	16.59	79.626	7.0	34.3	1,201	16,807
2.5	1.56	19.53	97.656	7.1	35.8	1,271	18,042
2.6	1.76	22.85	118.81	7.2	37.3	1,344	19,349
2.7	1.97	26.57	143.49	7.3	38.9	1,420	20,731
2.8	2.20	30.73	172.10	7.4	40.5	1,499	22,190
2.9	2.44	35.36	205.11	7.5	42.2	1,582	23,730
3.0	2.70	40.50	243.00	7.6	43.9	1,668	25,355
3.1	2.98	46.18	286.29	7.7	45.7	1,758	27,068
3.2	3.28	52.43	335.54	7.8	47.5	1,851	28,872
3.3	3.59	59.30	391.35	7.9	49.3	1,948	30,771
3.4	3.93	66.82	454.35	8.0	51.2	2,048	32,768
3.5	4.29	75.03	525.22	8.1	53.1	2,152	34,868
3.6	4.67	83.98	604.66	8.2	55.1	2,261	37,074
3.7	5.07	93.71	693.44	8.3	57.2	2,373	39,390
3.8	5.49	104.3	792.35	8.4	59.3	2,489	41,821
3.9	5.93	115.7	902.24	8.5	61.4	2,610	44,371
4.0	6.40	128.0	1,024.0	8.6	63.6	2,735	47,043
4.1	6.89	141.3	1,158.6	8.7	65.9	2,864	49,842
4.2	7.41	155.6	1,306.9	8.8	68.1	2,998	52,773
4.3	7.95	170.9	1,470.1	8.9	70.5	3,137	55,841
4.4	8.52	187.4	1,649.2	9.0	72.9	3,281	59,049
4.5	9.11	205.0	1,845.3	9.1	75.4	3,429	62,403
4.6	9.73	223.9	2,059.6	9.2	77.9	3,582	65,908
4.7	10.4	244.0	2,293.5	9.3	80.4	3,740	69,569
4.8	11.1	265.4	2,548.0	9.4	83.1	3,904	73,390
4.9	11.8	288.2	2,824.8	9.5	85.7	4,073	77,378
5.0	12.5	312.5	3,125.0	9.6	88.5	4,247	81,537
5.1	13.3	338.3	3,450.3	9.7	91.3	4,426	85,873
5.2	14.1	365.6	3,802.1	9.8	94.1	4,612	90,392
5.3	14.9	394.5	4,182.0	9.9	97.0	4,803	95,099
5.4	15.7	425.2	4,591.7	10.0	100.0	5,000	100,000
5.5	16.6	457.5	5,032.8				

# MINE VENTILATION.

(PART 2.)

---

## THE PRODUCTION OF VENTILATING CURRENTS.

---

### VARIOUS SYSTEMS OF INDUCING CURRENTS.

**1002. Ventilating Currents.**—The motion of air-currents in mines is caused by a difference in pressure between the two ends of the current, or, in other words, a difference in pressure between the downcast and upcast. The direction of the flow is always from the higher towards the lower pressure.

In the case of ventilation produced by exhaust-fans or furnaces, the higher pressure is the normal pressure of the atmosphere, and the lower pressure is that produced in the fan-drift, or at the bottom of the furnace-shaft. In the case of a blowing-fan, the higher pressure consists of the atmospheric pressure plus the pressure exerted by the fan, and the lower pressure is the atmospheric pressure at the top of the upcast. A waterfall in the downcast shaft produces motion in a current on the same principle as a blowing-fan, and a steam-jet in the upcast acts on the same principle as the exhaust-fan. However, it must be borne in mind that neither of the two latter methods is as efficient as a fan. These facts show clearly that the object of all artificial ventilating appliances must be to provide the required difference of pressure. Current motion may, therefore, be caused by either of two methods: (*a*) methods of compression, by means of which the air in the downcast is raised to a pressure greater than the atmosphere, or (*b*) methods of

§ 7

For notice of the copyright, see page immediately following the title page.



exhaustion, by means of which the pressure of the air in the upcast is made less than the pressure of the atmosphere.

**1003. The Laws of Current Motion.**—As a current of air for mine ventilation begins and ends in the atmosphere, it is necessary that a ventilator be applied to produce a terminal depression for the current to fall into, and a subsequent compression to finally force it out into the

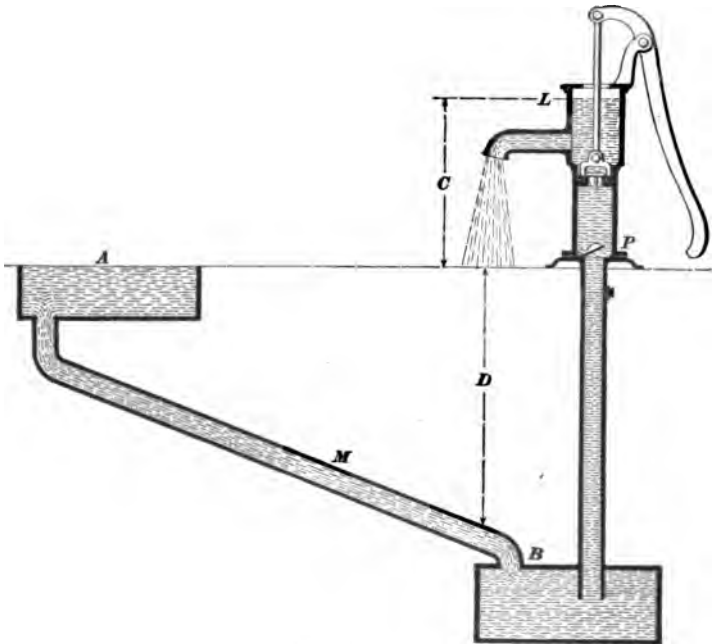

FIG. 150.

atmosphere. In Fig. 150 a pump is used to illustrate what has been expressed in words. The water in the cistern *A* is subject to the pressure of the atmosphere, and falls into a depression at *B*, through the pipe *M*. The depression at *B* is created by the pump in the same manner as a fan creates a depression. The excess of pressure in the atmosphere over that exerted at *B* is the measure of depression. It is this depression that causes the water to flow from *A* to *B*, and a similar depression that causes the air in a mine to flow

from the top of the downcast into the upcast. In the illustration, the pump  $P$  produces the depression. The lifting of the piston reduces the pressure of the atmosphere on the water in  $B$ , and the falling water pressed by the atmosphere at  $A$  rushes in to fill up the void. Without this depression, the water would naturally rise in the pump to the level of  $A$ , but would remain at rest and not flow out. Therefore, further energy is required to cause it to rise high enough to flow out of the nozzle. In the same way a fan must not only cause a depression, so as to cause the air to flow into the fan-drift, but it must also exert energy to force the air out into the atmosphere. In the case of the pump, to raise the water to  $L$ , and enable it to flow out of the nozzle, energy equal to a fall from  $L$  to the nozzle is required. This fall overcomes the friction and the delivery pressure, and is similar to the compression required in an exhaust-fan for it to throw the mine current out of its chimney. The illustration shows clearly that  $D$  is the measure of the depression below the pressure of the atmosphere, and that  $C$  is the measure of the compression above the atmosphere; further, it explains the principles of the double fall, or the fall from the atmospheric pressure at  $A$  to the depression at  $B$ , and the fall from the pressure above the atmosphere at  $L$  to the atmospheric pressure at  $A$ .

#### **1004. How Ventilating Currents Are Produced.—**

The means by which ventilating currents are produced are all included under the following heads:

- (a) Ventilation by natural heat.
- (b) Ventilation by artificial heat.
- (c) Ventilation by waterfalling.
- (d) Ventilation by mechanical agencies.
- (e) Ventilation by a steam-jet.
- (f) Ventilation by a water-jet.

**1005.** Natural ventilation is produced in a mine when the top of the upcast and the top of the downcast are at different elevations, or, in other words, when one is some distance up a hill and the other at or near the base, A

natural ventilating current is only set in motion when the temperature of the outer air and that of the walls of the mine passages is different. This method of ventilation differs from all others in one important respect, namely, the direction of the current is reversed in summer from what it is in winter. In summer, when the external air is hotter than the walls of the mine passages, the warm air descends the deeper shaft, and in so doing is cooled by the absorption of heat by the walls of the shaft. This cooled column thus becomes a heavier one than the one parallel to it, shown in (a), Fig. 151. In this figure,  $ab$  is the shaft and  $m$  is the mine. The cooled air column in  $ab$ , being heavier than the external column  $dc$ , causes the air to flow from  $b$  to  $d$ . The direction of flow in winter is illustrated in (b), Fig. 151.

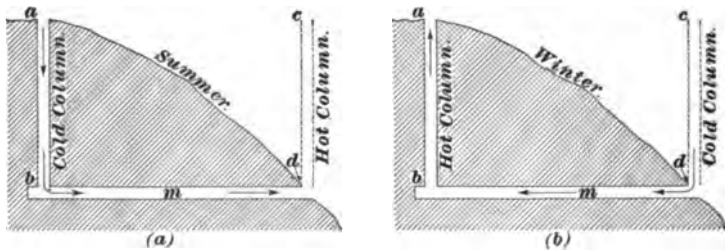

FIG. 151.

As the walls of the mine passages are warmer than the external air, the column of air in the shaft  $ab$  is warmer than the parallel column of the external air  $cd$ . Therefore, the external column being heavier forces the warmer, lighter column up the shaft, and causes the current to flow from  $d$  to  $b$ .

In the event of the external air having the same temperature as the walls of the mine passages, there is no flow of air-current, because one column balances the other.

**1006.** Ventilation by artificial heat is produced by a furnace fire situated at the bottom of the upcast shaft. This fire heats the column of air in the upcast shaft and makes it less dense and lighter than the column of cold air

in the downcast. The weight of a cubic foot of air in either shaft is calculated by formula 57,

$$W = \frac{1.3253 \times B}{(459 + t)}; \quad (57.)$$

$B$  = the barometric pressure in inches of mercury;

$t$  = Fahrenheit temperature of air in the shaft;

$W$  = weight of a cubic foot of air.

**EXAMPLE.**—The downcast shaft of a mine is 600 feet deep, the mean barometric pressure in the shaft is 30 inches, and the mean temperature of the air in the shaft is 62° F. What is the average weight of a cubic foot of air in this shaft?

**SOLUTION.**—Applying formula 57,

$$W = \frac{1.3253 \times 30}{(459 + 62)} = .07631 \text{ lb. Ans.}$$

**EXAMPLE.**—The upcast shaft of the same mine is 600 feet deep; the mean barometric pressure is the same (30 inches), and the mean temperature of the air in the shaft is 196° F. What is the average weight of a cubic foot of air in this shaft?

**SOLUTION.**—Applying formula 57,

$$W = \frac{1.3253 \times 30}{(459 + 196)} = .0607 \text{ lb. Ans.}$$

The two foregoing examples show that the air in the upcast shaft is lighter than that in the downcast.

Now, if the height of each column is taken at 600 feet, the ventilating pressure per square foot can be found by multiplying the weight of air per cubic foot by the height of the column in feet. Thus,

$$\text{Downcast} = .07631 \times 600 = 45.786 \text{ lb.}$$

$$\text{Upcast} = .0607 \times 600 = 36.420 \text{ lb.}$$

$$\text{Difference, or ventilating pressure per sq. ft.} = 9.366 \text{ lb.}$$

#### EXAMPLES FOR PRACTICE.

1. The downcast shaft of a mine is 437 feet deep, the mean barometric pressure is 30.25 inches, and the mean temperature of the air in the shaft is 67° F. What is the weight of a column of air in this shaft, having a base of 1 square foot? Ans. 33.8081 lb.

2. The downcast shaft of a mine is 1,147 feet deep, the mean barometric pressure is 29.9 inches, and the mean temperature of the air in

the shaft is 50° F. What is the weight of a column of air in this shaft, having a base of 1 square foot? Ans. 89.29395 lb.

3. The upcast shaft of a mine is 347 feet deep, the mean barometric pressure is 30 inches, and the mean temperature of the air in the shaft is 187° F. What is the weight of a column of air in this shaft, having a base of 1 square foot? Ans. 21.35785 lb.

4. The upcast shaft of a mine is 1,170 feet deep, the mean barometric pressure is 29.5 inches, and the mean temperature of the air in the shaft is 160° F. What is the weight of a column of air in this shaft, having a base of 1 square foot? Ans. 73.8972 lb.

### EFFECT OF TEMPERATURE ON VOLUME.

**1007.** The volume of a given quantity of air varies directly as its absolute temperature, the barometric pressure and weight remaining the same. This principle is expressed in formula **58**,

$$T = \frac{V}{v} \times (459 + t), \quad (58.)$$

in which  $T$  = absolute temperature of greater volume;

$V$  = greater volume;

$v$  = lesser volume;

and  $t$  = given temperature of lesser volume in Fahrenheit degrees.

**EXAMPLE.**—If the volume of a given quantity of air is 35,672 cubic feet when its temperature is 57° F., what must its temperature be to increase the volume to 51,756 cubic feet, supposing the atmospheric pressure and weight to remain the same?

**SOLUTION.**—Applying formula **58**,  $\frac{51,756}{35,672} \times (459 + 57) = 748.65^\circ$ , or the absolute temperature necessary for increasing the volume. Now, having the absolute temperature, it is necessary to reduce it to Fahrenheit temperature. This can be readily done by subtracting 459 from the absolute temperature. Then,  $748.65^\circ - 459^\circ = 289.65^\circ$  F. Ans.

### EXAMPLES FOR PRACTICE.

1. If the volume of a given quantity of air when its temperature is 60° F. is 46,732 cubic feet, what must its temperature be to increase the volume to 65,000 cubic feet, supposing the atmospheric pressure and weight to remain the same? Ans. 262.88° F.

2. If the volume of a given quantity of air when its temperature is 160° F. is 65,000 cubic feet, what must its temperature be when the volume is 50,000 cubic feet, supposing the atmospheric pressure and weight to remain the same? Ans. 17.1° F.

### THE MOTIVE COLUMN.

**1008.** The ventilating pressure can be found directly through the medium of the motive column. This motive column is the short column of air whose weight provides the ventilating pressure. If the length of this motive column is subtracted from the length of the downcast column, the weight of the remaining portion of the downcast column is equal to the weight of the upcast column. This is explained by Fig. 152, in which *U* is the upcast column and *D* is the downcast column; the furnace is shown at *F*, and *MC* is the motive volume. This motive column, then, is a column of air in the downcast shaft whose weight is equal to the excess of weight of the cold column over that of the hot one. The most convenient way to find the length of the motive column is by what is called Nicholas Wood's formula, which is based on the law that the weights of the columns are inversely as their absolute temperatures. This law can be expressed by formula 59,



FIG. 152.

$$M = \frac{(t - t_1)}{(459 + t)} \times D, \quad (59.)$$

in which  $t$  = higher temperature, or that of the upcast;  
 $t_1$  = lower temperature, or that of the downcast;  
 $D$  = depth of the shaft in feet;  
 and  $M$  = motive column.

Now suppose a case in which the mean temperature of

the downcast shaft is 58° F., and the mean temperature of the furnace shaft is 186° F., and the depth of the shafts is 800 feet. By formula 59, the length of the motive column in this case will be equal to  $\frac{(186 - 58)}{(459 + 186)} \times 800 = 158.75$  feet.

If, then, the average weight of a cubic foot of air in the downcast shaft is calculated by formula 57, and is found to be .077 pound, the ventilating pressure can be found by the following formula:

$$p = \frac{(t - t_1)}{(459 + t)} \times .077 \times D, \quad (60.)$$

in which  $p$  = ventilating pressure in pounds per square foot;

$t$  = higher temperature;

$t_1$  = lower temperature;

and  $D$  = depth of shaft.

Thus,  $\frac{(186 - 58)}{(459 + 186)} \times .077 \times 800 = 12.224$  pounds per square foot, the ventilating pressure required.

**EXAMPLE.**—The ventilating shafts of a mine are each 800 feet deep, the temperature of the downcast column is 58° F., and that of the upcast column is 202° F. What is the weight of a column of air in the downcast shaft 1 square foot in the base, and what is the weight of a column of equal length in the upcast shaft? Show by formula 60 that the difference between the weights of the two columns is equal to the weight of the motive column, the mean barometric pressure in the two shafts being 30.5 inches.

**SOLUTION.**—The weight of a cubic foot of air in the downcast shaft is, by formula 57, equal to  $\frac{1.3253 \times 30.5}{459 + 58} = .078185$  pound, and, by formula 57, the weight of a cubic foot in the upcast shaft is found to be

$$\frac{1.3253 \times 30.5}{459 + 202} = .061152 \text{ lb. Ans.}$$

Having found the weight of a cubic foot of air in each shaft, the weight of a column with a base of 1 square foot in each shaft is found by multiplying the weight per cubic foot of air in each shaft by the depth of the shaft; therefore, the weight of the downcast column equals  $.078185 \times 800 = 62.548$  pounds, and the weight of the upcast column equals  $.061152 \times 800 = 48.922$  pounds. The difference between the respective weights of the columns =  $62.548 - 48.922 = 13.626$  pounds.

By formula **60**, if the weight of the cubic foot of air is taken at .078, as the barometer is high,  $p = \frac{(202 - 58)}{(459 + 202)} \times .078 \times 800 = 13.594$  pounds.

It will be observed in this connection that the result secured by using formula **60** is a little less than that found by using the weights of the columns, but the difference arises entirely from the fact that the weight of a cubic foot in the downcast column is actually .078185 pound instead of .078; had the weight of a cubic foot of air been taken at .078185 pound, the answers would have agreed more closely.

#### EXAMPLES FOR PRACTICE.

**NOTE.**—The weight of 1 cubic foot of air at a temperature of 62° F., and a barometric pressure of 30 inches, is equal to .078 pound. This is close enough for the weight of a cubic foot of air for use in the following examples.

1. The ventilating shafts of a mine are each 950 feet deep, the temperature of the downcast column is 80° F., and that of the upcast is 230° F. (a) What is the length of the motive column? (b) What is the difference in the weights of the ventilating columns per square foot of area?

$$\text{Ans. } \begin{cases} (a) 234.4 \text{ ft.} \\ (b) 17.814 \text{ lb.} \end{cases}$$

2. The ventilating shafts of a mine are each 760 feet deep, the temperature of the downcast is 52° F., and that of the upcast is 230° F. (a) What is the length of the motive column? (b) What is the difference in the weights of the ventilating columns per square foot of area?

$$\text{Ans. } \begin{cases} (a) 234.5 \text{ ft.} \\ (b) 17.82 \text{ lb.} \end{cases}$$

#### VENTILATING BY FURNACES.

##### THE CONSTRUCTION OF FURNACES.

**1009.** As the furnace is still used in some regions for the ventilation of small mines where the output does not justify the erection of a ventilating fan, a few facts concerning its construction and use should be known. The object of a furnace is to produce a motive column by rarefying the air in the upcast shaft with heat. In shallow mines, however, where an efficient motive column can not be obtained,



the fan is much more efficient and economical. In spite of this, the furnace is still used. Therefore, its construction must be described.

Fig. 153 is an illustration of a type of furnace quite generally used. It is important, in building a furnace, to construct it so as to keep the excessive heat of the fire from the coal

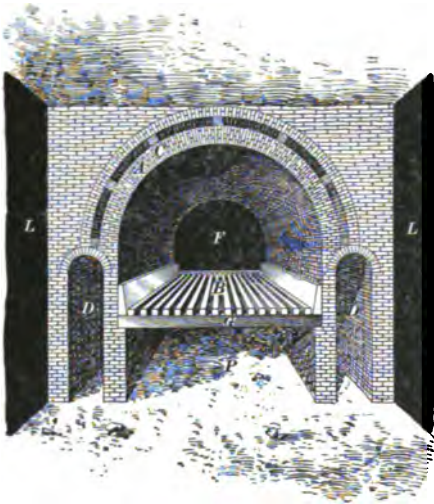

FIG. 153.

on its flanks, and from the rock above it. In Fig. 153, *L, L* show the sides in the coal-seam.

The drifts *D, D* provide for the isolation of the heat from the coal. Immediately above the fire is a double arch, and as the inner one is subject to constant variations of temperature, ribs of brick are run between the inner and the outer arch to prevent collapse, and to keep the air-space so widely

open that a current of air may freely pass through it and keep the heat from the roof. The importance of this arrangement is due to the fact that in cases where the roof stone contains water, the crown arch is continually buckling with the pressure produced by steam, and this causes the top stone to break and fall. *P* is the ash-pit, and *G* is the bearing-up bar, or front fire-grate girder. At *B* are seen the fire-bars that conjointly make up the fire-grate surface. The furnace arch is generally semicircular, and the height from the fire-bars to the under surface of the arch is generally  $1\frac{1}{4}$  times the width of the fire-grate surface. The dimensions of the furnace are determined on the basis of the amount of work it is intended to perform, and when the breadth of the furnace is found, all the other dimensions are deduced from it.

The length of the furnace-bars should not exceed 5 feet, and as this dimension is uniform for all furnaces, the important dimension required for constructing a furnace is its breadth. The area of the fire-grate surface varies inversely as the square root of the depth of the furnace-shaft. Before the width of a furnace can be determined, the amount of air necessary for the efficient ventilation of the mine must be fixed, and, in addition to this, the ventilating pressure in inches of water-gauge must be approximately known. From these factors, the horsepower of the required furnace can be calculated by dividing the product of the volume of air in cubic feet per minute and the pressure in pounds per square foot, by 33,000.

**EXAMPLE.**—Suppose a case in which the quantity of air required is 120,000 cubic feet per minute, and the probable mine resistance for that quantity is 2 inches of water-gauge ; what horsepower is required in the ventilation ?

$$\text{SOLUTION.}— \frac{120,000 \times 2 \times 5.2}{33,000} = 37.8 \text{ H. P. Ans.}$$

#### EXAMPLES FOR PRACTICE.

1. A mine is ventilated by an air-current of 200,000 cubic feet per minute, and the water-gauge reading is 2.1 inches ; what horsepower is exerted in moving the air ?  
Ans. 66.18 H. P.

2. A mine is ventilated by an air-current of 125,000 cubic feet per minute, and the water-gauge reading is 3.5 inches ; what horsepower is exerted in moving the air ?  
Ans. 68.94 H. P.

#### GRATE SURFACE.

**1010.** The fire-grate surface required is found by the following formula :

$$s = \frac{34}{\sqrt{D}}, \quad (61.)$$

in which  $D$  = depth of the furnace-shaft in feet ;

34 = a constant number proved by many experiments ;

and  $s$  = square feet of fire-grate surface required per horsepower of the ventilation.

**EXAMPLE.**—The depth of the shaft is 400 feet, and the horsepower required in the ventilation is 37.8 ; what area of fire-grate is required ?

**SOLUTION.**—By applying formula 61,  $\frac{84}{\sqrt{400}} = 1.7$  square feet of fire-grate surface required per horsepower. Since 37.8 horsepower is required, the fire-grate surface should be  $37.8 \times 1.7 = 64.26$  sq. ft. Ans.

A grate surface of the size calculated in the above example will efficiently ventilate a mine 400 feet deep, with 120,000 cubic feet of air per minute, circulated against a resistance equal to 2 inches of water-gauge. Again, if the bars of the fire-grate are 5 feet long, the breadth of the furnace, in feet, will in this case be equal to  $\frac{64.26}{5} = 12.85$  feet.

**EXAMPLE.**—Let a furnace-shaft be 900 feet deep, and the ventilating current be equal to 200,000 cubic feet per minute, with a mine resistance equal to 2 inches of water-gauge ; what must be the breadth of the furnace when the length of the fire-bars is taken at 5 feet ?

**SOLUTION.**—The horsepower required is equal to  $\frac{200,000 \times 2 \times 5.2}{83,000} = 63$  H. P. The fire-grate surface per horsepower, by use of formula 61, is found to equal  $\frac{84}{\sqrt{900}} = 1.133$  square feet ; and, therefore, the square feet of fire-grate surface required are equal to  $63 \times 1.133 = 71.379$  square feet ; and, if the length of the fire-bars be taken at 5 feet, the breadth of the furnace is equal to  $\frac{71.379}{5} = 14.28$  ft. Ans.

An examination of the two examples will show that, notwithstanding the fact that the horsepower required in the latter case is so much greater than in the former, yet the fire-grate surface is very little increased, owing to the greater depth of the shaft.

#### EXAMPLES FOR PRACTICE.

1. What grate surface will be required to produce a current of 200,000 cubic feet per minute, with a water-gauge of 2.1 inches, if the furnace-shaft is 900 feet deep ?  
Ans. 74.98 sq. ft.

2. What width of furnace will be required to produce a current of 100,000 cubic feet per minute, with a water-gauge of 2 inches, if the shaft is 625 feet deep, and the grate-bars of the furnace are 5 feet long ?  
Ans. 8.57 ft.

**REMARKS ON FURNACE VENTILATION.**

**1011.** Where furnace ventilation is practised and the return air contains inflammable gas, it is often necessary to feed the furnace with fresh air and use the heated gases from the fire to heat and rarefy the upgoing column of return air from the mine. In Fig. 154 the heated air from the furnace is marked *H*, and is seen to pass up that portion of the shaft at *S*. Again, nothing but the return air *R* is seen to pass the dumb drift *P*, as shown by the arrows. The return air unites and mixes with the heated gases of the fire at the junction of the dumb drift with the shaft. The furnace receives its supply of fresh air at *A*, as shown in section and plan. In the plan, the fresh air to feed the furnace is indicated by the arrow at *A*, and in the section the return air from the mine is seen to enter the dumb drift at *R*.

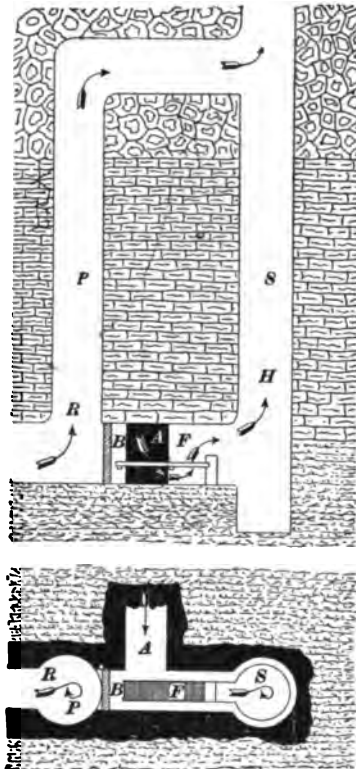

FIG. 154.

The object of this drift is to isolate the return air from the flaming gases of the furnace. The junction of the dumb drift with the shaft should not occur at a less elevation than 150 feet above the furnace, and in some cases where bituminous coal is burned, safety is not secured until the junction takes place at an elevation of 300 feet. As this is equal to the depth of many shafts, and more than the maximum depths of others where furnaces are used, it is clear that, at its best, the furnace does not afford a safe means for the ventilation of a gaseous mine.

### VENTILATION BY WATERFALLING.

**1012.** In some regions, waterfall ventilation is important, because it is cheap and very efficient. It often occurs,

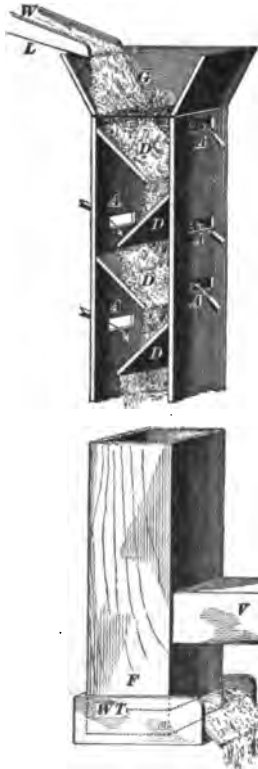

FIG. 155.

however, through oversight, that this agency is not adopted, although the conditions for its use are highly favorable. In Fig. 155 is shown what is called a **trompe**, or **waterfall ventilator**, in common use in many parts of the world, for the ventilation of such coal and metal mines as have the shaft bottom or lower level situated above the drainage level of the district. The trompe is a rectangular tube made of wood, and has an area of section equal to from 4 to 6 square feet. The length is regulated by the prevailing conditions, but the greater the length the better. The water delivered into the trompe generally comes from a neighboring stream and is conducted by a spout or trough *L*. Here the water is first divided into small streams by passing it through perforations in the top plate *G*. These water threads

are broken up by their inert force into drops that fall in succession from one to another of a series of sloping shelves that are called dashboards, as shown by *D, D, D, D*, etc. The water, on striking the upper board, rebounds, and the spray that is thus produced rains on to the under ones, and so on from one to another until the trompe becomes a vertical tube enclosing a shower of fine water-drops that produce a powerful, energetic blast of air. As the drops fall they produce a partial vacuum in their rear and a compression on their under

side, which causes an inrush of air into the ports *A, A, A*, etc. The water ultimately falls into a trap *W T*, where it overflows, and the air then blows out of the horizontal delivery branch of the ventilator at *V*. The trompe is used in the downcast shaft, and, therefore, acts as a blower to propel a current through the galleries of the mine.

**1013.** Where copious ventilation is required, an entire shaft is made to act as a large trompe, as in the case illustrated by Fig. 156. Here, however, instead of using a perforated plate, a brush mat

is provided for breaking up the water into spray, as shown between the buntons in the middle of the shaft. The water-flow is here conducted by a trough *W* into the spray-maker, where it is broken into drops and made to rain down the shaft in a rapid shower. This rain pro-



FIG. 156.

vides a powerful ventilation, and can be used with great advantage with a fall of from 100 to 200 feet. The arrangement is also cheap and economical where a copious mountain stream is available all the year round. So considerable is the pressure produced in this way, that waterfalls have been used to produce an air-blast for smelting iron in cupola furnaces. In some cases where water is available and can be used for ventilating mines, a vertical shaft to be used as a trompe is sunk on the side of a mountain at sufficient elevation above the top of the downcast. The bottom of the trompe is made a little below the top of the downcast shaft. The air from the fall is conducted into the downcast shaft by a drift, and to confine the air to the flow of the mine, the top of the shaft is covered with a trap-lid. The drift connecting the trompe and the downcast is extended past the downcast to the surface. The

water falling down the trompe is collected in a small sump, trapped into a trough in the drift, whence it flows past the downcast and runs away. Where the flow of water is copious, 200,000 or 300,000 cubic feet of air per minute can in this manner be supplied for the ventilation of a large mine.

---

#### **VENTILATION BY STEAM-JET AND WATER-JET.**

**1014. Ventilation by Steam-Jet.**—Sometimes a current of air is set in motion with a steam-jet projected into a channel along which the current moves, but economical results have not been obtained in this way.

**1015. Ventilation by a Water-Jet.**—Sometimes a jet of sprayed water is projected along the path of a current to produce ventilation. This method has not been very successful for producing large volumes of air, except when used as a waterfall, as previously described. But it has been applied with comparatively good results for producing a local current in a cheap and efficient way. It is only necessary, however, for the student to know that such means are used for setting currents of air in motion.

---

### **MECHANICAL VENTILATORS.**

---

#### **PRINCIPLES GOVERNING THE ACTION OF FANS.**

**1016.** Chief among the mechanical ventilators of mines is the centrifugal fan, and it is, therefore, important that its principles of construction and mode of action should be understood. The fan is really a valveless pump, its blades taking the place of the pump-piston, and, so far as the exhausting and blowing out of the mine air is concerned, the fan and the pump act in the same way.

To set a fluid in motion, the ventilating fan, like the pump, must overcome three distinct causes of resistance ; to make clear how these causes originate, an air-pump such

as shown in Fig. 157 is used. The first cause of resistance is that due to the friction of the mine. To show clearly its distinctive individuality, the pump is so contrived that no air can enter it without passing down the tube *A B* in the vessel at the left side of the figure; and to create an artificial resistance, the vessel just referred to is seen to be half filled with water, so that before any air can get inside of this closed vessel, two things must happen. First, the pump-piston *G* must move upwards, and, as a result of this movement, a depression of the air pressure will occur below the piston and above the water in the closed vessel. This

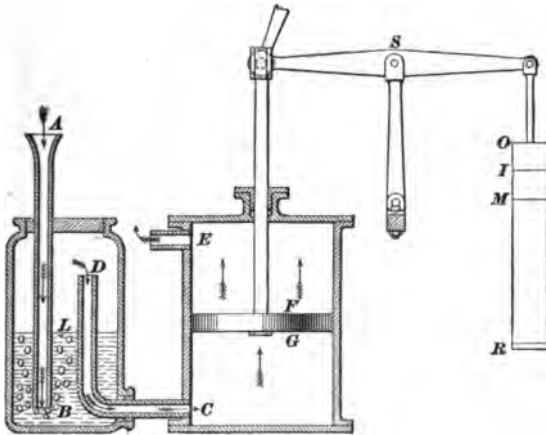

FIG. 157.

having taken place, the external air will by its greater pressure force the water down and out of the bottom end of the pipe *A B*, and it will then bubble up through the water and enter the pipe *D C* on its way into the cylinder, as shown by the arrow.

**1017. The Depressions Produced by the Working of a Fan.**—To make the depression required, the piston must move and produce a depression that will so reduce the pressure of the air in the cylinder and the vessel, that it will require the weight of the water the air displaces added to the pressure of the air within the vessel to equal the atmospheric pressure outside.



For example, suppose that the depth of the water through which the air must be forced is equal to 2 inches, or a pressure of 10.4 pounds per square foot. Then, if the outside pressure is equal to 2,116 pounds per square foot, the inside pressure can not be more than  $2,116 - 10.4 = 2,105.6$  pounds. The piston has here made such a depression as is found in a fan drift, and that is the equivalent of what is called the mine resistance, or the pressure required to set a current of air in motion through a mine. The use of a fan is to make this depression. The first, or principal depression, and the equivalent of the force required to produce it, is represented in Fig. 157 by a weight  $MR$  hung on the opposite end of the beam that turns on the center pin  $S$ . The entire use of the vessel  $DLB$  is to generate an artificial resistance to imitate a mine resistance.

**1018.** The second cause of resistance is that due to the force required to set the air in motion in the cylinder through the port  $DC$ . Air can not be set in motion out of the vessel  $DLB$  without a depression in the cylinder at  $GC$ , for air-currents move only from a higher to a lower pressure. Therefore, the piston must move sufficiently to make a displacement not only equal to the depression the weight  $MR$  would produce, but, in addition, a depression equal to that which the weight  $IM$  would produce. This means that the depression within the cylinder at  $GC$  must be equal to  $IM + MR = IR$ , while the depression within the vessel  $DL$  will only be equal to  $MR$ . The depression  $IM$  is the one which represents the depression required for the entry of air into a fan.

**1019.** From what has been stated, the student can see that two depressions must be made by the action of the fan. The first one is provided to cause the fall of a current from the atmosphere through the mine into the fan drift, and the second one is provided for the air in the fan drift to fall into the fan. As has been shown, the sum of these depressions is equal to the pressure represented by the weights  $IM$  and

*MR.* In addition to these, however, there is a third resistance, *O I*, which is the pressure required for the air to fall out of the fan into the atmosphere. The piston can not force the air out of the upper end of the cylinder without a difference between the inside and the outside pressure; altogether, then, the sum of the pressures required for a fan to do its work is equal to *O R*, or *O I + I M + M R*.

**1020.** The centrifugal ventilating fan furnishes the best agent for the economical ventilation of mines, for two reasons: first, it is safer than the furnace; and, second, its efficiency is uniformly the same for deep and for shallow mines; whereas the efficiency of the furnace is very small for shallow mines, and is not much greater than the fan in the ventilation of deep ones. From all points of view, then, the centrifugal fan is the best ventilating machine in use.

---

#### COMPARISON OF FAN AND FURNACE.

**1021.** The underlying principles of the modes of action of the fan and the furnace are so different as to require particular notice. The ventilating pressure produced by the furnace is the result of the difference in the weights of the ventilating columns; whereas the ventilating pressure produced by a fan is the result of a difference in the total pressures upon two shafts. For example, if a pair of shafts are 1,200 feet in depth, and are ventilated by a furnace with the temperature of the downcast column 62° F., and that of the upcast 135° F., then by formula **57** the weight of a cubic foot of each can be found as follows: In the downcast, the weight of a cubic foot of air is equal to  $\frac{1.3253 \times 30}{(459 + 62)} = .0763$  pound (see formula **57**), and the weight of a cubic foot of air in the upcast is equal to  $\frac{1.3253 \times 30}{(459 + 135)} = .0669$  pound. (See formula **57**.) The difference in the weights is, therefore, equal to  $.0763 - .0669 = .0094$  pound. The pressure, per square foot, producing ventilation under

the given conditions of depth and heat, is, according to formula 60,

$$\frac{(135 - 62)}{(459 + 135)} \times .0763 \times 1,200 = 11.252 \text{ pounds.}$$

**1022.** Fan ventilation is not produced, like furnace ventilation, by a difference in the weights of the ventilating columns. If, in the case of fan ventilation in the same shafts, the weight of a cubic foot of air in the downcast is equal to .0763 pound, the ventilating pressure of the fan is equal to that of the furnace, and the temperature of the upcast column is the same as that of the downcast one, namely, 62° F.; then, by taking the pressure of the atmosphere at 2,116 pounds per square foot, the weight of a cubic foot in the upcast shaft can be found by the following formula:

$$w = \frac{P - p}{P} \times W, \quad (62.)$$

in which  $w$  = weight of 1 cubic foot of air in the upcast;  
 $P$  = atmospheric pressure per square foot, or 2,116 pounds;  
 $p$  = ventilating pressure in pounds per square foot;  
 $W$  = weight of 1 cubic foot of air in the downcast.

Hence, in the case under consideration,

$$\frac{(2,116 - 11.252)}{2,116} \times .0763 = .075894 \text{ pound. Ans.}$$

The difference in the weight of a cubic foot of air in the downcast and of a cubic foot in the upcast is, therefore, equal to  $.0763 - .075894 = .000406$  pound. That is, the weights of the upcast and downcast columns are practically the same.

To produce a ventilating pressure of 11.252 pounds per square foot with a furnace and with a fan, the following curious differences occur:

Differences in the weights of a cubic foot of air:

Furnace ventilation, .0094 pound.

Fan ventilation, .000406 pound.

Difference in the total pressures upon the ventilating columns, in the given examples:

For furnace ventilation, none; because the motion of the current is caused by a difference of weight in the two columns.

For fan ventilation, 11.252 pounds; direct pressure, with practically no difference in the weights of the two columns.

Plainly stated, the facts are these: The furnace rarefies the air by heat, and the air flows because the rarefied column is lighter than the other column. The fan, by exhaustion or compression, makes the total pressure upon the top of one column greater or less than the pressure upon the top of the other column; so that, although the weights of the two columns are practically the same, the difference in pressure on the tops of the columns produces the flow.

**1023.** From what has been explained, it is easy to infer that the mode of action that characterizes the centrifugal fan is that of producing differences of pressure between the air entering and leaving a mine, and entering and leaving a fan. For example, if the absolute pressure of the air within the fan drift were not below the external pressure of the air entering a mine, the air could not be set in motion. It is clear, then, that the prime object of the fan is to make a depression at one end of the mine so that the greater pressure at the other will set the air in motion. Further, after the air has passed through the passages of a mine and has reached the fan drift, it can not enter the fan unless the pressure within the fan is less than that of the air in the drift. Therefore, a fan, to produce a ventilating current, must make a provision for two distinct depressions, one to cause the air-current to flow towards the fan and one to cause the current of air to enter the fan itself. Again, air can not leave a fan unless its pressure is raised above that of the external air. Then, if the air leaving is at a pressure greater than that of the atmosphere, it is clear that the work to be done is equal to that of producing a motive pressure equal to the sum of two negative pressures and the positive

one. That is, it is necessary in this case to make a depression equal to about 10 pounds on the square foot to overcome the mine resistance, and a further depression of about 2 pounds on the square foot is required to cause the air to enter the fan. The sum of these depressions becomes  $10 + 2$  pounds, or 12 pounds, on the square foot below the pressure of the atmosphere. Again, as the fan must make a compression for blowing the air out, say to 2 pounds on the square foot, the work of making the depression and the compression is altogether equal to  $10 + 2 + 2 = 14$  pounds on the square foot.

**1024.** The above principles of action are explained by Fig. 158, in which a funnel and the pipe  $AB$  represent the

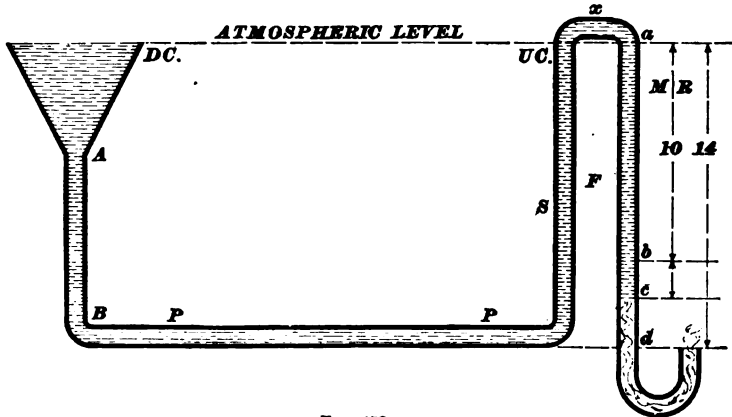

FIG. 158.

downcast shaft  $DC$ , and the pipe  $S$  forming one limb of the siphon represents the upcast shaft  $UC$ , while the descending limb  $F$  represents the depression and compression of a fan. It may be seen that, if at any moment the pressures or weights of the columns  $DC$  and  $UC$  are equal, the fluid will not flow through the pipes, because the atmospheric pressure will not force it through the elbow  $x$ ; but as soon as a portion of it fills the descending limb  $F$ , a depression takes place in the column  $S$  and the fluid falls from  $DC$  to  $UC$ . Now, let us apply this principle to show

how an exhaust-fan produces ventilation. The horizontal pipe  $PP$  takes the place of the galleries in a mine, and the columns  $AB$  and  $S$  take the place of the shafts, thus making  $AB$  the downcast and  $S$  the upcast shaft. The falling limb of the siphon  $F$  represents the exhaust-fan. It now becomes important that, through the medium of this diagram, the two depressions and the single compression generated by the exhausting-fan be studied. In the first place, the fan represented by  $F$  makes a depression into which the air of the mine falls. If the mine resistance is nearly equal to 2 inches of water-gauge, or 10 pounds on the square foot, it can be graphically shown, as in that portion of the diagram at the right-hand side of the figure, that  $ab$  is proportional to the depression required to overcome the mine resistance. Again, the depression required for the air to enter the fan is represented by  $bc$ ; hence, for the air to flow through the mine and fall into the fan, a depression must be made equal to  $ac$ . Further, a pressure above the atmosphere is required to blow the air out of the fan, as shown at  $cd$ . The total amount of pressure then required to cause the air to flow through the mine and fall into the fan, and to blow it out, is  $ab + bc + cd = ad$ .

---

#### CALCULATION OF VELOCITIES AND PRESSURES.

**1025.** In calculating the resistance due to the flow of air through mine passages only, the well-known formula

$$p = \frac{k s v^2}{a}$$

is used; but the pressure required to blow air into

a fan, and blow it out, must be found in a different way, because the conditions that originate the resistance are different. For example, the greater portion of the resistance met by a current flowing through a mine is generated by the rubbing surfaces of the airways; but there are no rubbing surfaces to produce resistances when air moves through an orifice that practically has no length, as in the case of the port of entry into a fan and the port of discharge out of it.

There are resistances that are peculiar to orifices that have no length, such as the *vena contracta*. Now, but for this interference with the movements of fluids, air at a pressure of 2,116 pounds on the square foot would rush into a vacuum with a velocity whose square would be equal to 1,800,000. After this number has been corrected for the resistance due to the *vena contracta*, it is reduced from 1,800,000 to 685,600.

**1026.** The *vena contracta* is that resistance due to the divergent and convergent movements of the particles of a fluid moving through an orifice. To make this clear, a reference to Fig. 159 will show that the air particles *a, c, e, f,*

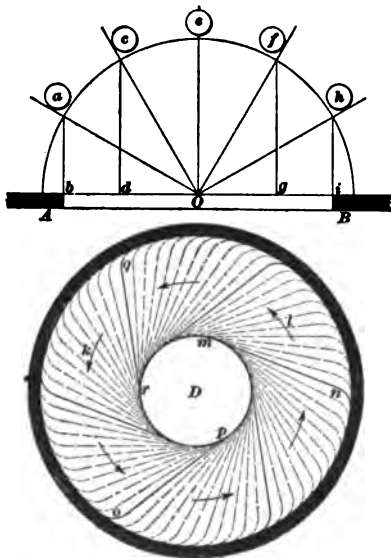

FIG. 159.

and *h* are all converging towards *O*, the center of a fan orifice. As a consequence, their velocities in lines parallel to each other, and perpendicular to the plane of the orifice, are quite different; for example, in the time that the particle *e* requires to move to *O*, *c* moves to *d*, and *a* to *b*, or *f* to *g*, and *h* to *i*. Again, while *a* moves to *b*, the same particle is tending to move from *b* to *O*; since the latter movement is prevented, the direction of the particle is deflected, and this contracts the neck of

the inverted cone of the inflow, and still further promotes the resistance at entry. Another cause of resistance is found in the whirl set up by the converging particles deflecting each other near the orifice, as at *D*, and this is the result of the velocities of the particles increasing as they accumulate in a reducing space, as *op, qr,* or *nm*. These

facts are still more clearly exemplified in Fig. 160. Here the lateral pressure has produced the contraction  $DD$ , and it is curious to observe that when the lateral pressure is relieved, the column swells out again to the full size of the orifice  $AB$ , and still further expands beyond the orifice, as at  $EE$ . Now, the result of these resistances is that the mean velocity of the inflow is reduced proportionately from 1 to .62;

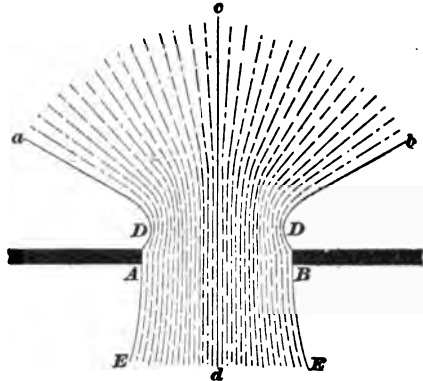

FIG. 160.

for air this is called the coefficient of the inflowing velocity, or the *vena contracta*. It may thus be seen that when the particles of a current flow along converging lines, the channel of the stream is constricted, and the general velocity is reduced.

**1027.** If it requires an atmospheric pressure of 2,116 pounds per square foot to cause air to blow through an orifice into a vacuum with a mean velocity whose square is 685,600, then the square of the velocity for any other pressure is readily found, when it is remembered that the squares of the velocities of air-currents vary directly as the pressures. This principle may be stated by the following formula :

$$v = \sqrt{685,600 \times \frac{p}{2,116}} \quad (63.)$$

in which  $p$  = given pressure in pounds per square foot,  
and  $v$  = velocity in feet per second.

Suppose the pressure is equal to 3 inches of water-gauge, or 15.6 pounds on the square foot; then, by formula 63,

$v = \sqrt{685,600 \times \frac{15.6}{2,116}} = 71.095$ , the velocity in feet per second. It should be observed, however, that 685,600 and



2,116 are constant numbers, and that they can be eliminated by substituting a single constant.

Dividing 685,600 by 2,116, and extracting the square root of the quotient, formula **63** becomes

$$v = 18 \sqrt{p}. \quad (64.)$$

**EXAMPLE.**—Required the velocity with which air will move through an orifice under a pressure of 15.6 pounds per square foot.

**SOLUTION.**—Applying formula **64**,

$$v = 18 \times \sqrt{15.6} = 71.095, \text{ the velocity in feet per second. Ans.}$$

The pressure required to blow air through an orifice when the mean velocity is given can be found by the formula

$$p = \left(\frac{v}{18}\right)^2. \quad (65.)$$

**EXAMPLE.**—If air is blowing through an orifice, such as the entry into a fan, with a velocity of 71.095 feet per second, what will be the pressure or depression required?

**SOLUTION.**—Applying formula **65**,

$$p = \left(\frac{71.095}{18}\right)^2 = 15.6 \text{ lb. per square foot. Ans.}$$

The following equations show how formulas **64** and **65** are obtained:

$$\sqrt{685,600 \times \frac{p}{2,116}} = 18 \times \sqrt{p} = v,$$

$$\frac{v^2}{685,600} \times 2,116 = \left(\frac{v}{18}\right)^2 = p. \quad \text{Ans.}$$

**1028.** The following examples will illustrate the use of the formulas given:

**EXAMPLE.**—The mean velocity of the air blowing into the orifice of entry of a fan is 25.5 feet per second; what is the depression in pounds per square foot required to give this velocity?

**SOLUTION.**—By formula **65**, the pressure will be equal to  $\left(\frac{25.5}{18}\right)^2 = 2.006$  lb. per sq. ft. Ans.

**EXAMPLE.**—The pressure by which air is blown into a fan is 2.006 pounds per square foot; what is the mean velocity of the entering air?

**SOLUTION.**—By formula **64**,  $v = 18 \sqrt{2.006} = 25.5$  ft. per sec. Ans.

**EXAMPLE.**—The orifice for the entry of air into a fan is 10 feet in diameter, and the pressure of the external atmosphere is 2,116 pounds per square foot; where the air reaches its maximum depression within the fan, its pressure is equal to 2,104.5 pounds per square foot; and the pressure within the fan drift is equal to 2,106 pounds per square foot. (a) What is the pressure that is effective in blowing the air out of the drift into the fan? (b) What is the pressure in pounds per square foot that is equal to the mine resistance? (c) What is the quantity of air entering the fan in cubic feet per minute?

**SOLUTION.**—(a) If the maximum pressure within the fan is 2,104.5 pounds per square foot, and the maximum pressure in the fan drift is 2,106 pounds per square foot, the effective pressure blowing air into the fan is equal to  $2,106 - 2,104.5 = 1.5$  lb. Ans.

(b) The pressure in pounds per square foot required to overcome the mine resistance is equal to  $2,116 - 2,106 = 10$  lb. per sq. ft. Ans.

(c) The velocity of the air entering the fan in feet per second can be found by formula 64; therefore, it is  $18 \times \sqrt{1.5} = 22.0446$  feet per second. If the diameter of the orifice of entry is 10 feet, the area of the orifice in square feet will be equal to  $10^2 \times .7854 = 78.54$  square feet; and as 60 times the velocity in feet per second is equal to the velocity in feet per minute, the following is the quantity of air entering the fan:  $78.54 \times 22.0446 \times 60 = 103,888$  cu. ft. per min. Ans.

**EXAMPLE.**—The depression necessary for air to enter a fan is 1.5 pounds per square foot. The orifice of entry is 10 feet in diameter, and the area of the orifice of discharge is  $\frac{1}{4}$  that of the orifice of entry. If, as has been shown, it requires 1.5 pounds per square foot to blow the air into the fan, what pressure per square foot will be required to blow it out?

**SOLUTION.**—The pressure to blow the air out will be inversely proportionate to the squares of the given areas. If the orifice of entry is 10 feet in diameter, then the area in square feet will be  $10^2 \times .7854 = 78.54$  square feet, and the area of the orifice of discharge will be equal to  $\frac{1}{4}$  of 78.54 = 58.905 square feet; then the pressure required to blow the air out of the fan will be equal to

$$\left( \frac{78.54}{58.905} \right)^2 \times 1.5 = 2.666 \text{ lb. per sq. ft. Ans.}$$

**EXAMPLE.**—The pressure required to overcome the frictional resistance of the air-currents in a mine is 12 pounds per square foot, and the quantity of air entering the fan is 150,000 cubic feet per minute. (a) What pressure is required to blow the air through an orifice of entry which is 12 feet in diameter? (b) What pressure will be required to blow the air out of the fan if the orifice of discharge has an area equal to  $\frac{1}{4}$  of the area of the orifice of entry? (c) What will be the range of

pressure between the pressure of discharge and the maximum depression within the fan ?

SOLUTION.—(a) To find the pressure required to blow the air into the fan, first find the velocity of the entering air in feet per second; that is, divide the quantity in feet per minute by 60 times the area of the orifice of entry, and the quotient will be the velocity in feet per

second; thus,  $v = \frac{150,000}{12^2 \times .7854 \times 60} = 22.1048$  feet per second. The pressure

blowing the air into the fan is, by formula 65,  $p = \left(\frac{22.1048}{18}\right)^2 = 1.50809$  lb. Ans.

(b) The area of the orifice of entry is  $12^2 \times .7854 = 113.0976$  square feet, and as the orifice of discharge is  $\frac{1}{4}$  of the area of the orifice of entry, it will be  $113.0976 \times \frac{1}{4} = 90.478$  square feet.

The volume of air in cubic feet per minute leaving the fan is exactly the same as that entering it; if the areas of entry and discharge are different, the velocities must be inversely proportional to the areas, because the velocity must be greater through a small area than through a large one. In this example the velocity through the large area is to that of the small one as 1 is to  $\frac{113.0976}{90.478}$ . Again, the pressures vary as the squares of the velocities, and, therefore, the pressure required to blow the air out is

$$\left(\frac{113.0976}{90.478}\right)^2 \times 1.50809 = 2.35639 \text{ lb. per sq. ft. Ans.}$$

(c) The total range of pressure between the pressure of discharge and the maximum depression within the fan can be found as follows:

Mine resistance . . . . .	12.00000 pounds.
Blowing-in pressure. . . . .	1.50809 pounds.
Blowing-out pressure. . . . .	2.35639 pounds.
Total . . . . .	15.86448 pounds. Ans.

EXAMPLE.—If a pressure of 2 pounds per square foot is required to blow air out of a fan which has an orifice of discharge equal to 95 square feet, what depression will be required to blow air into the same fan when the orifice of entry has an area of 120 square feet ?

SOLUTION.—As in the above example, the required pressure will be the ratio of the squares of the given areas multiplied by the given pressure; or  $p = \left(\frac{95}{120}\right)^2 \times 2 = 1.253472$  lb. per sq. ft., the pressure required to blow air into the fan. Ans.

**EXAMPLES FOR PRACTICE.**

1. The velocity of air blowing through an orifice is 45 feet per second; what pressure per square foot is required to give this velocity ?

Ans. 6.25 lb. per sq. ft.

2. When the pressure required to blow air through an orifice is equal to 5 pounds per square foot, what velocity will be produced ?

Ans. 40.2492 ft. per sec.

3. The velocity of air blowing through an orifice is equal to 180 feet per second; what pressure per square foot will be required to give this velocity ?

Ans. 100 lb. per sq. ft.

4. With what velocity can air be blown through an orifice under a pressure of 120 pounds per square foot ?

Ans. 197.18 ft. per sec.

5. If it requires a depression of 1.5 pounds per square foot for air to blow into the port of entry of a fan that is 12 feet in diameter, what pressure would be required to blow the air out through a port of discharge that is 10 feet in diameter ?

Ans. 3.1104 lb.

6. If it requires a pressure of 4 pounds per square foot to blow air through the port of discharge of a fan that has an area of 90 square feet, what pressure will be required for air to enter the same fan when the port of entry has an area of 150 square feet ?

Ans. 1.44 lb. per sq. ft.

7. What will be the total pressure of the air just within the port of entry of a fan when the atmospheric pressure is 2,116 pounds per square foot, the mine resistance is equal to 10.4 pounds per square foot, and the depression necessary for the air to blow into the fan is 1.2 pounds per square foot ?

Ans. 2,104.4 lb. per sq. ft.

**1029.** The total range of pressure by which a ventilating fan does its work extends from the maximum depression within the fan to the maximum compression without it

For example, suppose the following are the totals of the pressures:

Mine resistance . . . . . 10.0 pounds.

Blowing-in pressure . . . . . 1.5 pounds.

Blowing-out pressure . . . . . 2.0 pounds.

Total range of pressure . . 13.5 pounds.

The limits of the total range of pressure arise in this way: If the total pressure of the external atmosphere is 2,116 pounds per square foot, this constitutes an actual depression into which the air from the fan is blown; consequently, the maximum pressure in this example is  $2,116 + 2 = 2,118$ , and

the minimum pressure within the fan is  $2,118 - 13.5 = 2,104.5$  pounds per square foot. Now,  $2,118 - 2,104.5 = 13.5$  pounds, as previously shown.

**EXAMPLE.**—What pressure per square foot will be required to blow 150,000 cubic feet of air per minute into a fan (*a*) when the orifice of entry is equal to 10 feet in diameter, and (*b*) when the orifice of entry is equal to 5 feet in diameter?

**SOLUTION.**—(*a*) The velocity in feet per second of the air passing through the orifice 10 feet in diameter is found as follows:

$$\frac{150,000}{10^2 \times .7854 \times 60} = 31.831 \text{ feet per second. By formula 65,}$$

$$p = \left( \frac{31.831}{18} \right)^2 = 3.1272 \text{ lb. per sq. ft. Ans.}$$

(*b*) In the same manner the velocity of the air entering the orifice 5 feet in diameter is found to be  $\frac{150,000}{5^2 \times .7854 \times 60} = 127.328$  feet per second, and the required pressure, by formula 65, is equal to  $\left( \frac{127.328}{18} \right)^2 = 50.035$  lb. per sq. ft., the pressure per square foot required to blow 150,000 cubic feet of air per minute through an orifice 5 feet in diameter. Ans.

The pressure required to blow 150,000 cubic feet of air per minute through an orifice 5 feet in diameter is 16 times greater than the pressure required to blow air through an orifice 10 feet in diameter.

For, to blow equal quantities through unequal areas in equal times, the pressures vary inversely as the fourth powers of the diameters of the orifices. To prove the statement, let the quantity be 150,000 cubic feet of air per minute, and let the pressure for an orifice 10 feet in diameter be 3.1272 pounds per square foot; then the pressure per square foot required to blow the same volume of air per minute through an orifice 5 feet in diameter is equal to  $\left( \frac{10}{5} \right)^4 \times 3.1272 = 50.035$  pounds, as in the above example.

#### DIMENSIONS OF THE PORTS OF A VENTILATING FAN.

**1030.** To obtain the best results with the ventilating fan, the depression necessary for the entry of air should, if possible, not exceed one pound per square foot. Hence, the velocity should not exceed 18 feet per second; for, by formula

**64**,  $v = 18 \times \sqrt{p}$ , and  $18 \times \sqrt{1} = 18$ . Now, 18 feet per second is equal to  $18 \times 60 = 1,080$  feet per minute. Using this velocity, the diameter of the port of entry may be found by the following formula:

$$d = .0343 \sqrt{q}, \quad (66.)$$

where  $d$  is the diameter of the port of entry and  $q$  is the quantity of air flowing per minute through *one* port of entry. If there are two ports, that is, if the fan receives air on both sides,  $q$  is obtained by dividing the total quantity per minute by 2.

**EXAMPLE.**—What should be the theoretical diameter of the port of entry of a fan to pass 200,000 cubic feet of air per minute?

**SOLUTION.**—Using formula **66**,

$$d = .0343 \sqrt{q} = .0343 \sqrt{200,000} = 15.855 \text{ ft. Ans.}$$

**1031.** The area of the throat of a fan must be equal to the area of the curved surface of an imaginary cylinder whose diameter is equal to that of the port or ports of entry; and, as the length of this cylinder is exactly equal to the breadth of the fan-blades, it is important that the relationship of this area to that of the port of entry should be fully understood. The breadth of the blades or the length of the imaginary cylinder just referred to is found as follows:

Let  $d$  = diameter of port of entry;

$b$  = breadth of blades.

Then the curved surface of the imaginary cylinder is

$$3.1416 d b$$

the area of the port of entry is

$$.7854 d^2$$

Therefore,  $3.1416 d b = .7854 d^2$ ;

or,  $b = \frac{1}{4}d. \quad (67.)$

This formula is applied when there is but one port of entry.

When there are two ports of entry,  $b = \frac{1}{2}d$ .

**EXAMPLE.**—What should be the width of blade of a fan which is to deliver 160,000 cu. ft. of air per minute, there being one port of entry?

SOLUTION.—Using formula 66,

$$d = .0343 \sqrt[4]{160,000} = 13.72 \text{ ft.}$$

Now, applying formula 67,

$$b = \frac{1}{4}d = \frac{1}{4} \times 13.72 = 3.43 \text{ ft. Ans.}$$

EXAMPLE.—If 160,000 cubic feet are delivered per minute and there are two ports of entry, what should be the diameter of each port of entry and the width of the blade?

SOLUTION.— $q = \frac{160,000}{2} = 80,000$ . Using formula 66,

$$d = .0343 \sqrt[4]{80,000} = 9.7 \text{ ft. Ans.}$$

$$b = \frac{1}{4}d = 4.85 \text{ ft. Ans.}$$

The area of the port of discharge in an ideal fan should not be less than .81 of the area of the port of entry. It is true that few fans will work satisfactorily when this port is so large, but such fans can not give best results, because when the area of the discharge port is too much restricted, the excessive pressure required to blow out the air is much greater than it should be. Again, if there is not enough constriction in the port of discharge, there is bound to be excessive vibration of the air in the fan, necessitating the employment of a shutter. Therefore, .81 is far above the average proportion in many fans, but it is an ideal that should be sought for.

EXAMPLE.—The area of the port of entry of a fan is equal to 150 square feet, and the area of the port of discharge is .6 of this; then, if a pressure of 1 pound per square foot is required to blow the air into the fan, what pressure will be required to blow it out?

SOLUTION.—The pressures for blowing in and blowing out are inversely proportional to the squares of the areas; therefore,

$$\left( \frac{150}{150 \times .6} \right)^2 \times 1 = 2.77 \text{ lb. per sq. ft. Ans.}$$

EXAMPLE.—If the area of the port of entry of a ventilating fan is equal to 150 square feet, and the area of the port of discharge is equal to .81 of the area of port of entry, and if a pressure of 1 pound per square foot is required to blow the air into the fan, what pressure will be required to blow it out?

SOLUTION.—The area of the port of discharge will be  $150 \times .81 = 121.5$  square feet, and the pressure to blow the air out of the fan will be

$$\left(\frac{150}{121.5}\right)^2 \times 1 = 1.52415 \text{ lb. per sq. ft. Ans.}$$

EXAMPLE.—The area of the port of entry of a ventilating fan is 150 square feet, and the area of the port of discharge is .5 of the area of the port of entry. If it requires 1 pound of depression to blow the air in, what compression will be required to blow it out?

SOLUTION.—The area of the port of discharge will be  $150 \times .5 = 75$  square feet, and the pressure to blow the air out will, therefore, be

$$\left(\frac{150}{75}\right)^2 \times 1 = 4 \text{ lb. per sq. ft. Ans.}$$

### THE MANOMETRIC EFFICIENCY.

**1032.** **Manometric efficiency** is that percentage of the total pressure generated by a ventilating fan that is efficient in blowing the ventilating current through a mine. What is here called the total pressure consists of three additive quantities:

1. The mine resistance  $M$  in pounds per square foot, as measured with the water-gauge.
2. The depression  $I$  required for the air to enter a fan.
3. The pressure  $O$  required to blow the air out of a fan.

Let  $A$  = area of port of entry;

$a$  = area of port of discharge;

$C$  = manometric efficiency.

Then the pressure  $O$  is given by the following formula:

$$O = \frac{A^2}{a^2} \times I. \quad (68.)$$

The percentage of manometric efficiency  $C$  is found by formula **67**, where

$$C = \frac{100 M}{M + I + O}. \quad (69.)$$

EXAMPLE.—What is the manometric efficiency of a ventilating fan when the mine resistance is 2.5 inches of water-gauge, the depression at the port of entry of the fan is 2 pounds per square foot, the area of the port of entry is 100 square feet, and the area of the port of discharge is 60 square feet?



SOLUTION.—By formula 68,  $O = \frac{100^2}{60^2} \times 2 = 5.555$  lb.

Again, by formula 69,  $C = \frac{100 \times 13}{(13 + 2 + 5.555)} = 63$  per cent. Ans.

EXAMPLE.—Required the percentage of useful effect or manometric efficiency of a ventilating fan when the mine resistance is equal to 12 pounds per square foot, the depression required for blowing air into the fan is equal to 1 pound per square foot, and the compression for blowing the air out is equal to 1.5 pounds per square foot?

SOLUTION.—The total range of pressure is:

Mine resistance.....	12.0 pounds.
Blowing-in pressure.....	1.0 pound.
Blowing-out pressure.....	1.5 pounds.
Total .....	<u>14.5 pounds.</u>

The pressure required for mine resistance alone is 12 pounds; therefore, the efficiency of the fan, in so far as the ventilating of the mine is concerned, is  $\frac{12}{14.5} \times 100 = 82.7586$  per cent. Ans.

The last two examples are given to show the importance of making the ports of entry and discharge sufficiently large to prevent needless waste in the working of a ventilating fan.

EXAMPLE.—The mine resistance is equal to 10 pounds per square foot, the blowing-in pressure is equal to 2 pounds per square foot, and the area of the port of discharge is so small that the blowing-out pressure is 8 pounds per square foot; what is the percentage of useful effect, or manometric efficiency of the fan as a ventilator?

SOLUTION.—The total range of pressure is equal to the following sum:

Mine resistance .....	10 pounds.
Blowing-in pressure . . . . .	2 pounds.
Blowing-out pressure.....	8 pounds.
Total.....	<u>20 pounds.</u>

Therefore, the efficiency of the fan as a ventilator is equal to  $\frac{10}{20} \times 100 = 50$  per cent. Ans.

EXAMPLE.—A fan is exhausting from a mine 180,000 cubic feet of air per minute, and the area of the port of intake is 60 square feet; what is the pressure required for blowing the air into the fan?

**SOLUTION.**—First find the mean velocity of the entering air in feet per second as follows:

$$\frac{180,000}{60 \times 60} = 50 \text{ feet per second;}$$

therefore, by formula 65, the required pressure is  $(\frac{50}{4})^2 = 7.716$  lb. per sq. ft. **Ans.**

#### EXAMPLES FOR PRACTICE.

1. What is the manometric efficiency of a fan when the mine resistance is equal to 15 pounds per square foot, the blowing-in pressure is 2 pounds per square foot, and the blowing-out pressure is 5 pounds per square foot? **Ans.** 68.18 per cent.

2. The manometric efficiency of a fan is 70 per cent., and the mine resistance is 8 inches of water-gauge; what are (a) the blowing-in and (b) the blowing-out pressures when the area of the port of discharge is .6 of the area of the port of entry? **Ans.** { (a) 1.7672 lb. per sq. ft.  
(b) 4.918 lb. per sq. ft.

#### CENTRIFUGAL FORCE.

**1033.** The tendency of every body in motion is to move in a straight line, unless the body is acted upon by some force which causes it to deviate from the straight line. In the case of a body attached to a string and moving in a circle, the deviating force is the pull exerted by the string, and is called **centripetal force**. The so-called **centrifugal force** is that force which is equal and opposite to the centripetal force; in other words, it is a reaction. Centrifugal force can not cause motion; hence, if the string were cut, the centripetal force would no longer act, and the body, being then free to move, would start off in the direction of a straight line tangent to the circle, as shown by the line *eg* in (a), Fig. 161. Centrifugal force is manifested under two conditions. In the first case there is a uniform deflection and a uniform velocity with a constant radius, as, for instance, when a body is made to rotate with a uniform velocity at the outer extremity of a constant radius. The centrifugal force can be found by the formula

$$f = \frac{w v^2}{R g}, \quad (70.)$$

in which  $w$  = weight in pounds;

$v$  = velocity in feet per second;

$R$  = radius in feet;

$g$  = acceleration due to gravity, or 32.16;

and  $f$  = force in pounds pulling the body towards the center of its revolution.

This is a case like that in which a pound weight might be made to revolve on the end of a string, and should the string at any moment be cut, the weight would simply move off in a line tangent to the curve.

In the second case, the centrifugal force, the velocity, and the radius are constantly increased, and correspond to the centrifugal force developed by a ventilating fan, which develops a velocity outwards from the center of revolution. To explain the difference, take a case in which a pound weight is made to revolve within a tube instead of being attached to the end of a string. Now, if the tube moves with the same speed as the string, the pound weight will move outwards along the inside of the tube. The velocity thus acquired will cause the weight to move in a path situated between the tangent to the curve and the prolongation of the radius at the point of disengagement, instead of in a path tangential to the curve of the outer circle. The body revolving on the end of the fixed radius has, at the moment of disengagement, acquired only sufficient centrifugal force to make it describe a path tangential to its circle; whereas, the body moving through the tube has, in addition to the centrifugal force of the former body, acquired a force due to an increased outward acceleration.

The force acquired in the second case is calculated by the formula

$$f = \frac{w v^2}{3.1416 g}, \quad (71.)$$

in which the factors are the same as in formula 70, except that the constant 3.1416 is substituted for  $R$ .

**1034.** In (*a*), Fig. 161, both of the above cases are illustrated. The radius of the circle described by the first

body revolving is  $oe$ , or  $oh$ , and if this body is by any means disengaged, as, for example, by the breaking of a string, at the instant it is passing the point  $e$ , the body will reach the point  $g$  at the moment it should have arrived at  $h$ , having moved along the line  $eg$ , which is tangent to the curve  $eh$ . If, however, the same body is made to revolve in a tube and also to commence its outward journey at the center  $o$ , by the time it reaches  $e$  it will have acquired a high outward velocity that the fixed body can not possess. Therefore, at the moment of disengagement it will move off in the path  $ef$ , and will arrive at  $f$  in as short a time as the

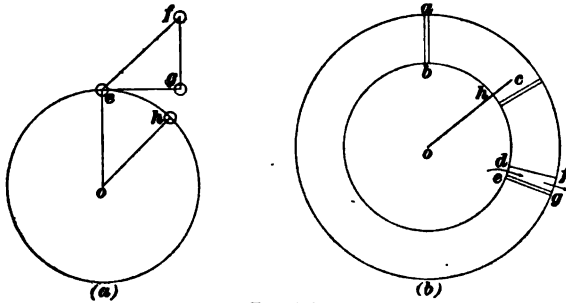

FIG. 161.

first body will require to reach  $g$ . The result is that the velocity developed by a continual deflection and acceleration is much greater in amount than that due to a body revolving with a uniform velocity on the outer extremity of a radius of constant length.

**DEFINITIONS OF TERMS.**

**1035.** The centrifugal force developed by a fan is calculated by the following formula :

$$f = \frac{w l v^2}{3.1416 g}. \quad (72.)$$

Before giving examples that involve the use of formula **72**, the meaning and use of its factors must be explained. For example, the velocity is obtained from the length of the radius of gyration, and this is obtained by adding to the radius of the port of entry a fraction of the radial length of

the blades, the latter being found by multiplying the radial length by .6. The radial length of the blades is found by the formula

$$l = \frac{D - d}{2}, \quad (73.)$$

in which  $D$  = diameter of the fan;

$d$  = diameter of the port of entry;

and  $l$  = radial length of the blades.

**EXAMPLE.**—The diameter of a fan is 30 feet, and the diameter of the port of entry is 12 feet. What is the radial length of the blade?

**SOLUTION.**—By formula 73, the radial length of the blades is  $\frac{30 - 12}{2} = 9$  ft. Ans.

**1036.** In (*b*), Fig. 161, is given a graphic illustration of the terms in question. For example, taking  $o$  as the center of a fan,  $c$  is situated at the center of gyration, and  $oc$  is the radius of gyration. As  $oh$  is the radius of the port of entry,  $oh + hc$  (or, what is the same thing,  $oh + ab \times .6$ ) is equal to the radius of gyration. This is expressed by the formula

$$r = \frac{d}{2} + .6l, \quad (74.)$$

in which  $r$  is the radius of gyration. When air is flowing along the blades of a fan, all the air on the blades, from the periphery of the port of entry to the outer periphery of the fan itself, is subject to centrifugal force, and, as the blades may be 9 or 10 feet long, to find the weight of air subject to centrifugal force, the weight of a cubic foot of air is multiplied by  $l$ , the length of the blades; this is the meaning of the expression in formula 72, where  $wl$  occurs as two of the factors.

Now, it must be clear that the velocity of the moving air at  $b$  is much less than it is at  $a$ ; and, therefore, the mean of the squares of the velocities, multiplied by the weights, occurs at the center of gyration  $c$ , for a stream of air lies on every blade, as that shown at  $d e g f$ . An example will make this clear :

**EXAMPLE.**—A ventilating fan is 30 feet in diameter, the radial length of the blades is 9 feet, and the length of the radius of gyration is 11.4 feet; (a) what is the mean velocity generating centrifugal force when the fan is making 50 revolutions per minute? (b) What is the total pressure produced? (c) What is the quantity of air passed per minute?

**SOLUTION.**—The velocity generating centrifugal force in feet per second will be equal to  $\frac{11.4 \times 2 \times 3.1416 \times 50}{60} = 59.69$  feet per second, the required velocity. From this velocity, the total pressure in pounds per square foot to produce the two depressions already noticed and the compression for blowing out can be found by formula 72. In the case for which the velocity has been calculated, the length of the blade is 9 feet; if the average weight of a cubic foot of air is taken at .076 pound, formula 72 gives  $f = \frac{.076 \times 9 \times 59.69^2}{3.1416 \times 32.16} = 24.11$  pounds per square foot. Next, suppose that the mine resistance in a case like this is equal to 3 inches of water-gauge, or 15.6 pounds per square foot, and the depression within the fan is 4 pounds per square foot below that in the fan drift, and that the pressure per square foot for blowing out is 4.51 pounds above the atmosphere. These figures yield the factors for calculating the quantity of air that this fan is exhausting out of the mine in cubic feet per minute. By formula 64,  $v = 18 \sqrt{p} = 18 \times \sqrt{4} = 36$  feet per second, the mean velocity of the air entering the fan. Next, the port of entry, which is circular, is  $30 - 2l$ , or  $30 - 18 = 12$  feet in diameter, and its area is  $12^2 \times .7854 = 113.0976$  square feet. 36 is the mean velocity in feet per second, and, therefore,  $36 \times 60 = 2,160$ , the velocity in feet per minute. If the area found be multiplied by the mean velocity in feet per minute, the result will be the quantity of air exhausted by the fan in cubic feet per minute, as  $113.0976 \times 2,160 = 244,290.8$  cubic feet of air per minute. Ans.

**EXAMPLE.**—A ventilating fan is 28 feet in diameter, and the diameter of the port of entry is 10 feet; what is the radial length of the blades?

**SOLUTION.**—By formula 73,  
 $l = \frac{D - d}{2}$ ; then,  $\frac{28 - 10}{2} = 9$  feet, the radial length of the blades. Ans.

**EXAMPLE.**—A ventilating fan is 28 feet in diameter, and the orifice of entry is 10 feet in diameter; what is the length of the radius of gyration?

**SOLUTION.**—By formula 74,  

$$r = \frac{d}{2} + .6 \times l;$$
 or,  $r = \frac{10}{2} + (.6 \times 9) = 10.4$  ft., the radius of gyration. Ans.  
 F. I.—27

**EXAMPLE.**—The radius of gyration for a ventilating fan is 9.5 feet, and the length of blade is 7.5 feet; the diameter of the orifice of entry is 10 feet; the angular velocity is 50 revolutions per minute; what is the total range of the fan's ventilating pressure?

**SOLUTION.**—The velocity per second is equal to  $\frac{9.5 \times 2 \times 3.1416 \times 50}{60} = 49.742$  feet; then, by formula **72**,

$$f = \frac{w l v^3}{3.1416 g} = \frac{.076 \times 7.5 \times 49.742^3}{3.1416 \times 32.16} = 13.96 \text{ lb.}$$

the total ventilating pressure. Ans.

**1037. The Center of Gyration.**—The calculations thus far given are based on the assumption that the blades of the fan lie longitudinally in radial lines, but in many cases this does not occur. Therefore, it is necessary to be able to make the expressions adaptable for fans in which blades make different angles with the radii. Now, when the blade makes an angle with the radius, its efficient length is practically shortened in the proportion of the cosine of the angle. For example, suppose a blade makes an angle of  $45^\circ$  with the radius projected from the circumference of the port of entry; then the efficient length of the blade is only .7 of its actual length, as shown in Fig. 162, in which  $AB$

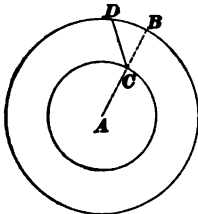

FIG. 162.

is the radius,  $CD$  the actual length of the blade, and  $CB$  the efficient length of the blade. Again, when the blades make an angle with the radii, the efficient angular velocity, that is, the number of revolutions, is practically reduced in the proportion of the cosine of the angle which the blades make with the radii. For, suppose a case in which the fan is making 50 revolutions per minute. The 50 would be reduced by the cosine of the angle, because where the blades decline from the radii, the relative efficiency of the velocity is only for an angle of  $45^\circ$ , which is equal to  $50 \times .7 = 35$  revolutions per minute. To make this allowance, the expressions may be simplified by multiplying the number of revolutions by the square of the cosine; formula **72** thus becomes

$$f = \frac{w l v^2 (\cos a)^2}{3.1416 g}, \quad (75.)$$

in which  $a$  = angle the blades make with the radii in every case;

$f$  = total pressure per square foot;

$v$  = velocity of the center of gyration in feet per second;

$l$  = actual length of the fan blades;

$w$  = weight of a cubic foot of air, or .076;

$g$  = acceleration due to gravity, or 32.16;

and 3.1416 = a constant.

If, for example, the blades of a fan are each 8 feet long, and are so set as to make an angle of  $30^\circ$  with the radii, and the velocity of the center of gyration is 60 feet per second, the total pressure, by use of formula 75, is calculated as follows:

$$f = \frac{3,600 \times .076 \times 8 \times .86603^2}{3.1416 \times 32.16} = 16.25 \text{ lb., total pressure.}$$

**1038.** The importance of being able to calculate the mean velocity of a current of air flowing outwards along the blades of a fan can not be overlooked, because, when this velocity is not known, the formula adopted only secures a rough approximation of what a ventilating fan is capable of doing. To understand the matter, the student must first have clear views concerning how air moves in its passage through a fan, and the best way of obtaining this is to consider in order the three components of the resultant motion.

**1039.** *First.*—The angular velocity is that due to the revolution of the fan. As all the particles in a current of air flowing along the blades of a fan make a revolution round the common center of motion in the same time, it is necessary to explain how the angular velocity affects the sum of the work of a fan. Angular velocity means the same thing as revolutions per minute or per second, for the angular velocity increases or decreases directly as the number of revolutions increases or decreases.



**1040.** *Second.*—While all the particles of air within a fan have the same angular velocity, the linear velocities

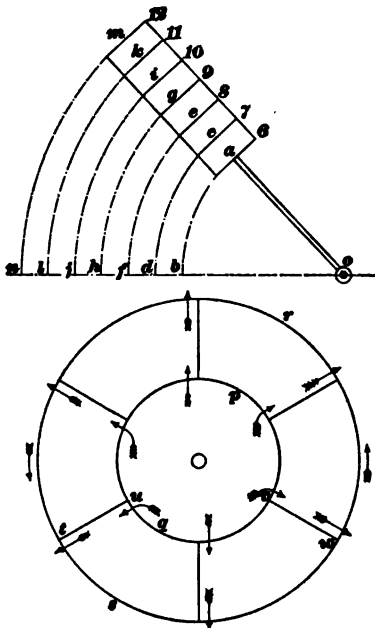

FIG. 163.

are directly proportional to their radial distances from the center of motion; for example, all the particles marked 6, 7, 8, 9, 10, 11, 12, in the upper portion of Fig. 163, have the same angular velocity; that is, they all make one revolution in the same time, but their linear velocities are different, for they are all describing circles of different lengths. The linear velocity of 6 is proportional to the length of the arc  $ab$ . The linear velocity of 12 is proportional to the length of the arc  $mn$ , and the same relationship holds true with all the other numbers.

**1041.** *Third.*—What is called radial motion is the flow of the stream of air along the blades of a fan. There are many mistaken ideas in regard to this motion. For example, the common idea is that the currents of air entering a fan diffuse between the diverging blades, and, therefore, the velocity reduces as the divergence increases. A little consideration, however, shows the error of this conclusion. The air-currents, as a whole, flow through a fan with an unvarying velocity, for the weight of the air leaving a fan can never exceed the weight of the air entering it, but the particles making up the currents have different velocities in the direction of the fan's motion. Again, the increasing effect of the centrifugal force, as the stream advances to the circumference of the fan, tends more and more to prevent

any increase in the depth of the flow; indeed, it tends rather to reduce it. This is fully proved on watching the contraction that takes place in a river where it contracts its flow as the result of the effect of the centrifugal force that is generated by a bend in the channel. The flow of the air is such as indicated by the arrows along the blade of the fan, as seen in the lower portion of Fig. 163. The fan is supposed to be turning in the direction of the hands of a watch, and the inner circular space within the fan blade is the port of entry, or the orifice by which all air enters a fan.

**1042. The Evase Chimney.**—Fig. 164 is an illustration of four important points. The first is the fan drift illustrated by the round tube *I*; the second is the fan-drift depression, as shown by the water-gauge *D*; the third is the water-gauge *G*, that shows the depression that occurs within the fan; and the fourth is the greater pressure or compression of the air at discharge, as shown by the water-gauge *P*. These points have all been explained. *E* is the evase chimney used to reduce the amount of waste that occurs in blowing air out of a fan into the external atmosphere. In the case of the Guibal fan, for instance, where the orifice of entry is relatively small and the velocity of discharge is relatively high, if something is not done to reduce the high velocity, the blast of air striking the comparatively still air of the atmosphere causes a rebound that produces great resistance. The evase chimney is used to reduce this needless loss of energy in the discharged air. To show the efficiency of an evase chimney, assume the orifice of discharge from the casing to the chimney

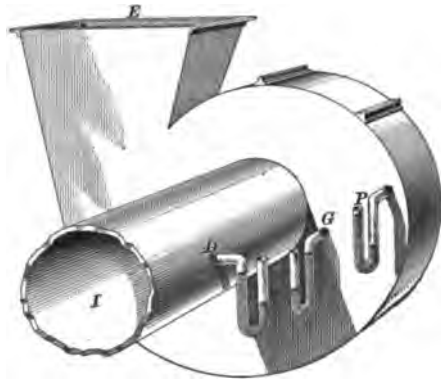

FIG. 164.

by the water-gauge *P*. These points have all been explained. *E* is the evase chimney used to reduce the amount of waste that occurs in blowing air out of a fan into the external atmosphere. In the case of the Guibal fan, for instance, where the orifice of entry is relatively small and the velocity of discharge is relatively high, if something is not done to reduce the high velocity, the blast of air striking the comparatively still air of the atmosphere causes a rebound that produces great resistance. The evase chimney is used to reduce this needless loss of energy in the discharged air. To show the efficiency of an evase chimney, assume the orifice of discharge from the casing to the chimney

to be equal to 50 square feet, and the area of the top of the evase chimney to be equal to 200 square feet. Now, the velocity of discharge at the top of the evase chimney will only be one-fourth of the velocity of the air blowing through the orifice of discharge of the fan, and as the resistances that arise when air at a high velocity strikes still air are proportionate to the squares of the velocities, the resistance due to the air leaving the top of the evase chimney is to the resistance of the higher velocity as  $50^2$  is to  $200^2$  or as 1 is to 16.

#### EXAMPLES FOR PRACTICE.

1. What is the centrifugal force in pounds due to a 5-pound weight revolving on the end of a rigid radius under the following conditions: Length of radius, 6 feet; number of revolutions per second, 10?

Ans. 3,682.7 lb.

2. What is the pressure per square foot due to a stream of water flowing through a pipe that is rotating on one of its ends, the length of the pipe being 5 feet and making 2 revolutions per second?

Ans. 4,395.9 lb. pressure per sq. ft.

3. A ventilating fan is 25 feet in diameter, and the port of entry is 10 feet in diameter. What is the radial length of the blades?

Ans. 7.5 ft.

4. A fan is 25 feet in diameter, and the diameter of the port of entry is 10 feet. What is the length of the radius of gyration?

Ans. 9.5 ft.

5. A ventilating fan is 25 feet in diameter, the port of entry is 10 feet in diameter, and the radius of gyration is 9.5 feet. What is the velocity in feet per second of the center of gyration when the fan makes 45 revolutions per minute?

Ans. 44.7678 ft. per sec.

6. The velocity of the center of gyration of a ventilating fan is 44.7678 feet per second, and the radial length of the blades is 7.5 feet. What is the total pressure generated by the fan to overcome the mine resistance, and to set the air in motion into and out of itself?

Ans. 11.9032 lb. per sq. ft.

#### TYPES OF FANS.

**1043.** Centrifugal fans are used for blowing and exhausting. Exhausting fans are in most general use, though there are many advocates and users of the blowing-fan. So far as mechanical efficiency is concerned, exhaust-fans and blowing-fans are practically equal.

The general principles of each are the same, except in reverse order. The exhaust-fan draws from the mine and discharges into the outer atmosphere, while the blowing-fan draws from the outer atmosphere and discharges into the mine.

**1044. Prominent Types of Fans.**—The most prominent types of centrifugal ventilators now in use in mining countries are four in number, the principal representatives of which are (a) *Waddle*, (b) *Schiele*, (c) *Guibal*, (d) *Capell*. These four will be described as representing the main features of all other forms, which are modifications of these original types.

**1045. The Waddle Fan.**—The characteristic features of the *Waddle* fan, Fig. 165, are the *curvatures of its blades*—backwards from the direction of their motion; their tapered form, tapering towards the circumference, and the tight box sides, which revolve with the blades. The blades leave the orifice of intake radially, but curve backwards from the direction of their motion till they are almost tangential at the circumference. The blades are so tapered from the orifice of intake to the circumference that the breadths of the blades at

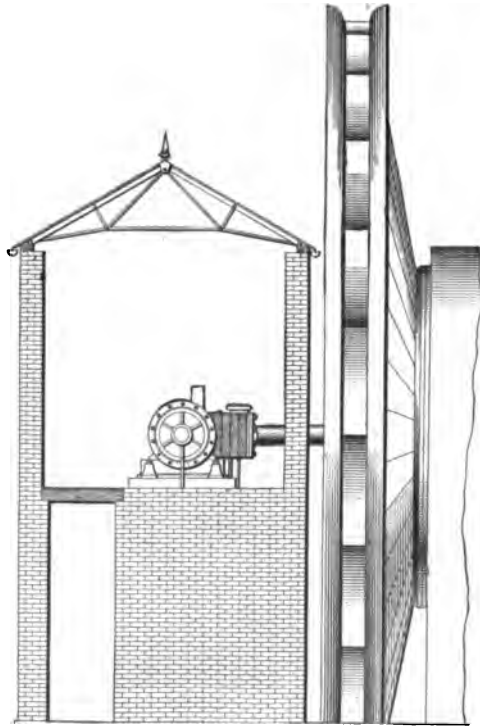

FIG. 165.

different distances from the center of the fan-wheel vary inversely as the radial lengths of the points at which the breadths are measured.

**1046.** The **Schiele fan**, Fig. 166, very much resembles the Guibal fan in its mode of action, although its construction is in some important respects quite different. In the Schiele fan a disk takes the place of the spider wheel in the Guibal fan, and this makes necessary the duplication of the blades, for they are attached on opposite sides of the disk. The disk makes a complete partition within the fan, and, therefore, the supply of air to the blades must come from two ports of entry, one for each set of blades. The Schiele fan

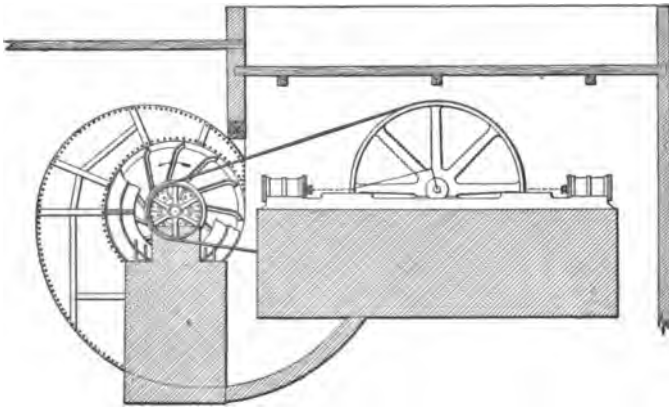

FIG. 166.

is a fast-running one, and, therefore, to do the same amount of work its diameter is only about one-third that of a Guibal fan of the same capacity. By reference to the figure, it will be seen that this fan is set within a spiral casing surrounding the circumference and leading to an expanding or evase chimney. The student must notice carefully the effect of the spiral casing surrounding the circumference of the Schiele fan, as it is a most important factor in fan construction. It provides a uniformly increasing sectional area

about the fan, to accommodate the flow from each compartment. The velocity of the air is thus made uniform all around the circumference, and each compartment furnishes its proportion of air in a continuous flow. In exhausting, the discharge from the casing is conducted to the expanding chimney, where its velocity is much reduced, before it is finally thrown out upon the atmosphere. In force or blower fans, the expanding casing should connect with the mine passages by a uniformly expanding fan drift.

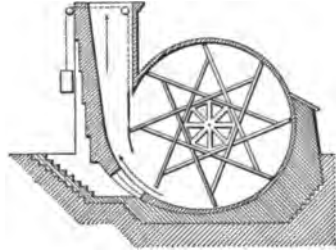

FIG. 167.

#### 1047. The Guibal Fan.

—This fan revolves within a closed case and delivers its air into an involute chamber, which gradually expands into the evase chimney. The fan is illustrated by Fig. 167.

**1048. The Capell Fan.**—This fan is constructed somewhat after the type of the Guibal fan, with considerable additions and improvements, such as is illustrated by Fig. 168. All the centrifugal fans in use, however, may be put into two groups; namely, closed and open fans. Among those just noticed, the Waddle is an

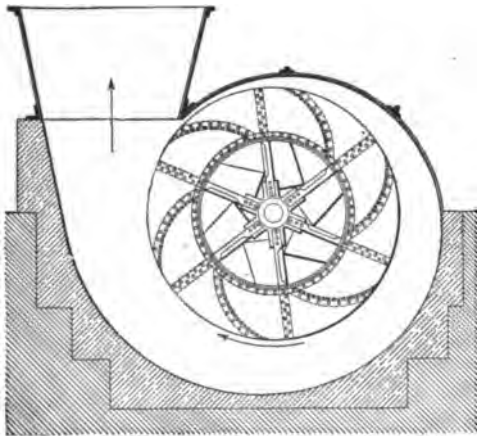

FIG. 168.

open fan; the Schiele, the Guibal, and the Capell are closed fans.

## PRACTICAL VENTILATION.

---

### QUANTITY, VELOCITY, AND CONDUCTION OF AIR.

**1049. Use of the Air-Current.**—The necessity for the air-current in mines is threefold, viz: (1) to furnish fresh air to the men and animals in the mine; (2) to sufficiently dilute and render harmless the poisonous and explosive gases of the workings; (3) to remove these by sweeping them from their lodging places or the cavities in which they are lodged.

**1050. Efficient Ventilation.**—The efficient or thorough ventilation of a mine is dependent upon three essential elements:

- (a) Volume of the current.
- (b) Velocity of the current.
- (c) Manner of conducting the current.

**1051. Volume of Air Required.**—The quantity of air required to be furnished per minute to the workings of a mine is usually fixed by the law of the state or country in which the mine is located. The amount specified is usually 100 cubic feet per minute per man, and 500 cubic feet per minute per mule, in non-gaseous mines. In gaseous mines this amount is increased to 150 cubic feet per man, and, in some cases, as in the anthracite mines of Pennsylvania, 200 cubic feet per minute are required by law. This method of fixing the amount of air required is purely arbitrary, and often not adapted to the existing conditions, as the workings in a thin seam will have an abundance of air and, perhaps, too high a velocity, while in a thicker seam the velocity will be too low for proper ventilation.

**1052. Velocity of the Current.**—This is a very important factor in the ventilation of a mine, as upon it largely depends the removal of the mine gases. A body of firedamp or of marsh-gas which is exuding or has collected in some cavity of the roof, or at the face of some rise heading, will require a current having a certain velocity to dilute

it and drive it from its position. In like manner, the heavier gases, as carbonic acid gas, settling towards the dip workings and low places of the pit, can not be carried out if the velocity of the current is too low. The current velocity should not be permitted to fall below 3 or 4 feet per second at any working face.

**1053.** On the other hand, too high a velocity of the ventilating current is always objectionable, and, in gaseous mines, dangerous. The Anthracite Mine Law of Pennsylvania provides that all air-passages shall be of a sufficient area to allow the passing of 200 cubic feet of air per man per minute at a velocity not exceeding 450 feet per minute; and this velocity may be taken as a safe maximum limit in gaseous mines. It must be remembered that a safety-lamp carried against a current is virtually subjected to a velocity equal to that of the current plus the velocity with which the lamp is carried against the current. In non-gaseous mines, the velocity of the main intake may be anywhere from 10 to 20 feet per second without causing serious annoyance. In many cases it exceeds this amount. It should not fall below 3 or 4 feet per second in any airway in the mine.

**1054. Conducting the Current.**—The thorough ventilation of the working face in any mine is dependent to a large extent upon the manner in which the doors, stoppings, brattices, and overcasts, or bridges, are erected. These must not leak. **Doors** must be hung with a fall sufficient to close behind a passing car, and must be fitted tightly to a substantial frame. Where the ventilating pressure is light, a door is sometimes hung to swing both ways, to save trapping. Ordinarily, however, this can not be done, and the door must then be hung to open against the current. Canvas flaps are sometimes nailed to the bottom of a door to prevent leakage and allow of good clearance. Double doors are often used in cross-cuts near the shaft bottom between the main airway and the return. The object of double doors is to prevent the momentary stoppage of the ventilating current when a car is passing through the



cross-cut. The doors are set from 6 to 8 yards apart, or farther, if the length of the cross-cut will permit. **Stoppings** are commonly built of a double wall of slate, with a few inches of space between. This space is filled completely to the roof with fine sand or clay from the surface, or with dirt taken from the roads. Stoppings upon the main air-courses of large mines are often plastered with clay, or laid up with brick instead of slate walls. **Brattices** are partitions, usually of wood or canvas (brattice-cloth), for the purpose of dividing the airway for a short distance, near the face into an intake and a return. A **curtain** is a heavy canvas hung across an airway or the mouth of a room to partially turn the air. A curtain serves as a regulator, inasmuch as it permits a portion of the air-current to pass it, while the remaining portion is forced into another passageway.

**1055. Regulators** are contrivances for regulating the division of the air between two or more airways. The usual form of regulator is shown in Fig. 147, and consists of a wooden brattice built across the airway and having an opening provided with a shutter, by which the size of the opening may be increased or decreased, and thus any desired division of the air secured. **Bridges** are built in airways for the purpose of crossing the air-currents. A bridge may be an **overcast**, as shown in Fig. 169, in which *C* is the coal-



FIG. 169.

seam, *G* is the main airway, and *R* is an overcast cut out of the roof for the purpose of conducting a current of air over or under another current. If the cross-current is conducted under the main airway, it is called an **undercast**. In this case the *bridge* forms the floor of the main airway and the roof of the cross-cut. The dis-

advantages of the *undercast* are: (1) water is apt to close the passage; (2) the bridge is more difficult to keep airtight, being subject to travel of mules and cars; (3) if the cross-current is the intake, the air is made unwholesome by the dust of travel being sifted down through the bridge floor. The bridge floor is usually made by laying a double thickness of plank upon cross-stringers of railroad iron or oak, and covering the whole with dirt from the roadways.

**1056.** Fig. 170 is an illustration of the practical arrangement of stoppings, brattices, and curtains. *A B* are a

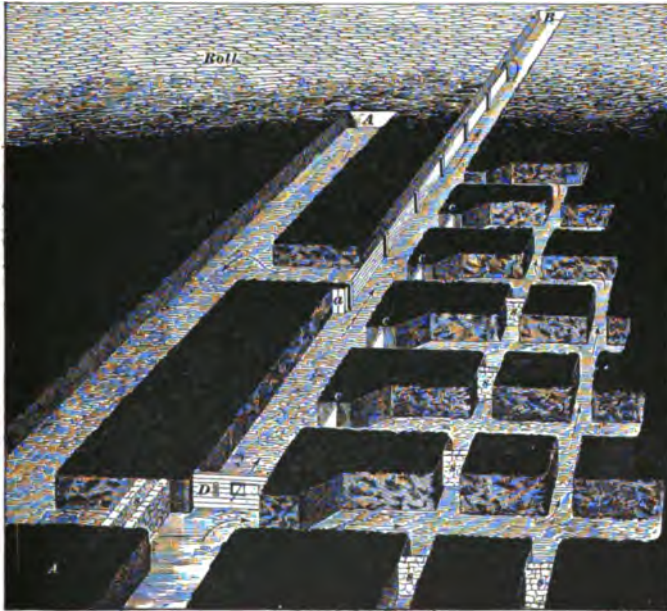

FIG. 170.

pair of entries which struck a roll. The entry *A* was abandoned for the time, and *B* was driven ahead as a fore-winning or prospect entry. For this purpose a temporary brattice was erected from the outside rib of the last cross-cut at *A*, towards the face of the entry *B*, by setting a row

of props two feet from the rib of the entry, and nailing brattice-cloth or light boards to them. The air-current is then forced to travel towards the face before it can return to the cross-cut behind the brattice. An entry stopping and room stoppings are shown at *s, s, s*. Curtains are hung at the mouths of all the rooms, except the outside and inside ones, which are left open. A curtain or a door is then hung upon the entry at *D*, just inside the mouth of the first room, which deflects the current into the face of the rooms. A curtain at *D* will usually accomplish this, but if the room workings are extensive, a door should be used and an opening left in it, or at one side of it, sufficient for the ventilation of the portion of entry thus cut off from the current. This example will serve to illustrate a practical method of conducting a current of air through a mine. It is sometimes necessary to deflect the current so that it will sweep a particular cavity of the roof or point of the entry, where a dangerous body of gas would otherwise collect. Wherever this is necessary, attention must be given to it, as no system of ventilation will be efficient unless the air is made to brush the gas from all of its lodging places. The *volume* of the current may be sufficient, and it may travel at the required *velocity*, yet the ventilation of the working places will be poor, unless the air is properly conducted and sweeps the entire face and roof.

---

## INSTRUMENTS.

---

### INSTRUMENTS FOR MEASURING THE RESISTANCE OF AIRWAYS.

**1057.** The instruments for measuring the resistance of air are:

- (a) *Pressure*.—Water-gauge and manometer.
- (b) *Velocity*.—Anemometer.

The student has learned that the intake pressure of an airway is always greater than the return pressure. The difference of pressure is measured usually by means of a

water-column in one arm of a bent glass tube. This instrument is called a **water-gauge**.

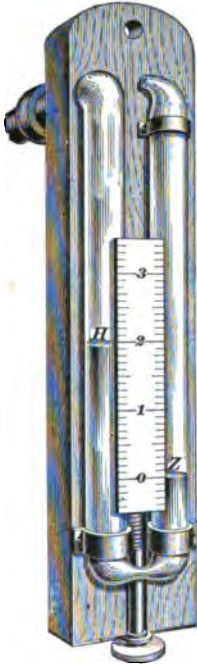

FIG. 171.

**1058. The Water-Gauge.**— Fig. 171 shows the usual form of water-gauge in use in the mines. The scale is divided into inches and decimals of an inch and is movable, in order that its zero can be adjusted to the lower water-level by means of the thumb-screw below. The tube is bent into the form of a letter U, both arms being open at the top to the free admission of air. The left-hand arm at the top, however, is cemented into a brass tube which makes a square bend, passing through the wooden base to which it is secured, so that the open tube can be connected with the opposite air-current to measure the difference in pressure.

Fig. 172 shows the water-gauge in position upon a mine door or brattice, in a cross-cut between the intake and return airways. *C* is the intake and *D* the return of the mine. One of the open ends of the gauge-tube *A* is thus subject to the intake pressure, while the other end is acted upon by the return pressure.

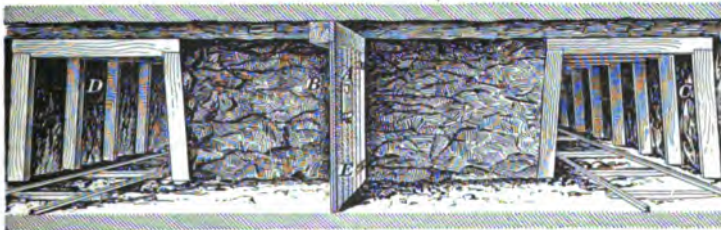

FIG. 172.

These pressures being unequal, their difference will be equal to the weight of water which is unbalanced in the gauge.

When the pressure of the air upon each end of the gauge is equal, the water will stand at the same height in each arm; if, now, the pressure be increased upon one end, the level of the water in that arm will sink, while it rises in the other an equal amount. Suppose that the intake pressure over that of the return is sufficient to cause the water-level to sink 1 inch in the arm open to the intake. The level of the water in the other arm will rise 1 inch. Now, by moving the scale until its zero corresponds exactly with the lower water-level, the reading of the upper level will be 2 inches. This will represent 2 inches of water-column, balanced only by the ventilating pressure of the mine.

**1059.** To calculate the pressure per square foot of area which supports this water-column: The weight of 1 cubic foot of water (62.5 pounds) corresponds to a pressure of 62.5 pounds per square foot for 12 inches of water-column; and 1 inch of water-column or water-gauge will, therefore, be equivalent to  $\frac{62.5}{12} = 5.2$  pounds pressure per square foot.

Hence, to calculate the pressure  $p$  in pounds per square foot of sectional area, when the water-gauge  $W$  is given in inches, the formula  $p = 5.2 W$  is used.

*That is, the unit of ventilating pressure or the pressure upon each square foot of the sectional area of an airway, in pounds, is 5.2 times the reading of the water-gauge in inches.*

**1060.** The reading of the water-gauge must always be taken between the intake and the return current, and as near the mouth of the return current as possible, in order that it shall express the full resistance of the mine.

**1061. The Anemometer.**—This is a wind-gauge for measuring the velocity of a current in an airway by timing the revolutions of the vanes. Fig. 173 shows the most reliable form of anemometer.  $A$  is a wind-wheel whose revolutions are indicated by the registering dials at  $B$ . These dial-hands are so geared to one another and to the spindle, or axle, of the vane, that the divisions upon each dial represent 10 revolutions of the next preceding dial-hand, and each

division of the large circle corresponds to 1 revolution of the vane. There are 100 divisions in the large circle; and, therefore, 1 revolution of the large hand denotes 100 revolutions of the vane. One revolution of the dial-hand *c* denotes



FIG. 173.

10 revolutions of the large hand *B*, or 1,000 revolutions of the vane. Thus, the dials in Fig. 173 register 2,118 revolutions of the vane.

**1062.** The vanes are inclined at such an angle that 1 revolution of the vane corresponds to 1 foot of travel of the air in the airway. There is a disconnecting device shown near the handle by which the registering dials can be instantly thrown out of gear, which makes it possible for the operator to take more accurate readings. One important point to be borne in mind, in taking careful measurements of the current passing in an airway, is that the velocity is

not the same in all parts of the passage. The friction of the current upon the sides and top and bottom of the airway retards the air nearest to these surfaces. As a consequence, the air rolls, as it were, in whirling circles upon these surfaces. The velocity of the current is, therefore, greatest at the center of the passageway and least in the corners.

**1063.** In Fig. 174 is illustrated a common method of obtaining a fair average reading for the entire area of the entry.

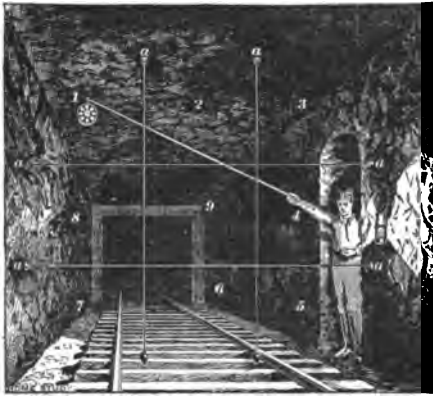

FIG. 174.

The passageway is divided into 9 equal squares by the imaginary vertical and horizontal lines  $aa, aa$ , etc.

The anemometer is held in each of the outer squares for the same length of time, say 15 seconds, moving it from one to another in regular succession, and is then held in the center square for a period as

long as that of the other 8 squares combined, thereby occupying  $\frac{8 \times 15}{60} \times 120 = 240$  seconds, or 4 minutes. Suppose,

when this has been carefully done, the reading of the anemometer is as shown in Fig. 173 (2,118); then the average velocity for the entire area of the airway would be  $\frac{2,118}{4} = 529\frac{1}{2}$  feet per minute. The quantity of air  $q$

passing in the airway per minute is calculated by the formula

$$q = av.$$

When using the anemometer, the operator should endeavor, as far as possible, not to obstruct the passageway or contract its area by his body. He should stand to one side of

the center of the passage and make allowance for his body, especially when the sectional area of the airway is small. The anemometer should be held at right angles to the direction of the current. Consideration must also be given to the fact that an air-current, like a water-current, moves in channels. The velocity of the air will always be found very much greater along the rib of an airway which corresponds to the outer circle of a bend. The instrument held by this rib will often show a good velocity, while close to the other rib there is scarcely sufficient motion to obtain a reading. In fact, velocity measurements should be taken, if possible, where the passage is straight and smooth.

---

**INSTRUMENTS FOR MEASURING DENSITY OF AIR.**

**1064.** The instruments for determining the density of air are :

- (a) The *barometer*, for measuring atmospheric pressure.
- (b) The *thermometer*, for finding the temperature of the air.

The density of air depends mainly upon two factors, barometric pressure and temperature. When these are known, the weight of 1 cubic foot of air is easily determined by formula 57.

**1065. The Barometer.**—This instrument has been previously described in another paper, and will only be referred to here. Its use is important in all mining operations, where mines are opened on an extensive scale. It is often found in the offices of large mining companies, connected with a continuous self-registering apparatus that records the barometric height for every hour.

**1066. The Thermometer.**—The temperature of the air is determined by the thermometer, which is a glass tube having a small bulb blown upon the lower end. The bulb and a portion of the tube are filled with mercury, the upper end being closed, after boiling the mercury, to expel the air. The tube is attached firmly to a base, as shown in Fig. 175, which is then graduated so as to mark the degrees of



temperature by the expansion of the mercury, which rises and falls in the stem.

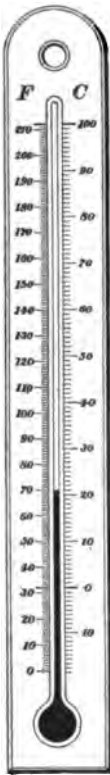

FIG. 176.

There are two thermometer scales in common use, the Fahrenheit scale, marked *F* in the figure, and the Centigrade scale, marked *C*. They differ principally in the location of the zero mark.

The **Centigrade scale** is a decimal scale. Its zero is marked by the freezing-point of water, while the boiling-point is marked 100°.

The **Fahrenheit scale** is the scale most used in America and in England. The freezing-point of water is marked 32° above zero, and the boiling-point 212° above zero.

**1067.** By comparing these two scales, it can be seen that 100° on the Centigrade scale correspond to  $212 - 32 = 180^\circ$  on the Fahrenheit, or 5 degrees C. = 9 degrees F. Hence, to convert any Centigrade reading into the corresponding Fahrenheit reading, use the following formula:

$$F = \frac{9}{5} C + 32, \quad (76.)$$

in which *F* is the Fahrenheit reading and *C* the Centigrade reading. That is,  $\frac{9}{5}$  of any Centigrade reading, plus 32, is equal to the corresponding Fahrenheit reading, attention being paid to plus and minus readings, when above or below zero, respectively.

To convert any Fahrenheit reading into the corresponding Centigrade reading, use the following formula:

$$C = \frac{5}{9} (F - 32), \quad (77.)$$

in which the letters have the same meaning as in formula **76**. That is, from the given Fahrenheit reading subtract 32, and take  $\frac{5}{9}$  of the remainder; the result will be the corresponding Centigrade reading.

**NOTE.**—In each of the two preceding rules, all readings, of either scale, above zero are plus, and all below zero are minus. A few examples will make the method clear.

**EXAMPLE.**—Convert  $50^{\circ}$  C. into the corresponding Fahrenheit reading.

**SOLUTION.**—Using formula 76,

$$F = \frac{9}{5} \times 50 + 32 = 122^{\circ} \text{ F. Ans.}$$

**EXAMPLE.**—Convert  $-10^{\circ}$  C. into the corresponding Fahrenheit reading.

**SOLUTION.**—Using formula 76,

$$F = (\frac{9}{5} \times -10) + 32 = -18 + 32 = 14^{\circ} \text{ F. Ans.}$$

**EXAMPLE.**—Convert  $-30^{\circ}$  C. into the corresponding Fahrenheit reading.

**SOLUTION.**—Using formula 76,

$$F = (\frac{9}{5} \times -30) + 32 = -54 + 32 = -22^{\circ} \text{ F. Ans.}$$

**EXAMPLE.**—Convert  $-4^{\circ}$  F. into the corresponding Centigrade reading.

**SOLUTION.**—Using formula 77,

$$C = \frac{5}{9}(-4 - 32) = \frac{5}{9} \times -36 = -20^{\circ} \text{ C. Ans.}$$

The student will notice that in these formulas, 32 is added and subtracted algebraically; that is, when the signs are like, the quantities are added together, their sum having the same sign; but when the signs are unlike, the lesser quantity is subtracted from the greater, and the remainder takes the sign of the greater. Thus, in the solution of example 2, where  $+32$  is added to  $-18$ , subtract 18 from 32, and the remainder, 14, takes the plus sign. In example 3, subtract 32 from 54, and the remainder, 22, takes the minus sign.

#### EXAMPLES FOR PRACTICE.

1. What temperature Fahrenheit corresponds to  $100^{\circ}$  C.? Ans.  $212^{\circ}$  F.
2. Convert  $290^{\circ}$  Centigrade into the corresponding Fahrenheit reading. Ans.  $554^{\circ}$  F.
3. What reading upon the Centigrade scale corresponds to  $5^{\circ}$  Fahrenheit? Ans.  $-15^{\circ}$  C.
4. Convert  $-40^{\circ}$  Fahrenheit into the corresponding Centigrade reading. Ans.  $-40^{\circ}$  C.

#### AIR COLUMNS.

**1068.** In speaking of the *natural* means at hand for producing ventilation, *heated air columns* have been treated. It is important to notice that since air has weight, *all* columns of air exert a downward pressure upon the area of

their base equal to the weight of the column. Also, the downward pressure of air columns creates an *equal* pressure in every direction upon the air of each level of the airway. That is, the pressure throughout each level section is the same; but if the elevations of the sections are different, the pressure in each section will be different. The pressure per square foot of sectional area in the airway due to any air column is equal to the weight of a column of air of the same height and having a uniform section of 1 square foot from bottom to top.

**1069.** Air columns may be vertical, as in the case of the furnace shaft *BA*, Fig. 176, or inclined, as in the case of the slope air column *CE*.

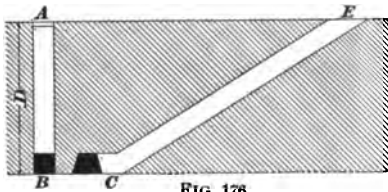

FIG. 176.

In either case, the pressure at the base upon 1 square foot of sectional area, due to the weight of the air column, is calculated from its *vertical height*. In the figure, the depth of the shaft *D* is equal to the vertical height of the slope, and for the same temperature the pressures per square foot of sectional area, due to these two air columns, are equal.

**1070.** As explained previously, the difference in the weight of two air columns connected by an airway at their bases causes the air to flow through the airway, from the heavier towards the lighter column. It can readily be seen that the weight of one of these columns is **positive**, while that of the other is **negative**, so far as concerns the motion of the air-current. The weight of the *positive* column always acts in the direction in which the current moves in proportion to its excess of weight over the negative column. Thus, the excess of weight of the positive air column causes the flow of the current.

**1071.** It is a matter of common observation in mines that **rise workings** are more difficult to ventilate than **dip workings**, when the bottoms of the shafts are on the dip

side of the workings. The reason for this is found in the fact that the intake air, or that flowing to the rise, is always cooler and denser than the return air, which has become heated by the higher temperature of the workings, and which must flow down grade to the upcast. The effect of this will be to *retard* the ventilation of the workings.

On the other hand, if the intake runs to the *dip*, as in dip workings, and the continuous flow of the air is upward to the upcast, there will result a *heavy* positive column and a light *negative* column; the combined effect of these will *assist* the ventilation.

The influence of dips and rises in mine workings is thus seen to be a powerful one, in fact often completely controlling the ventilation of the workings. For this reason, seams having any considerable inclination should be so ventilated that as far as practicable the course of the current will be towards the rise. This is known as **ascensional ventilation**, and is an important consideration in the ventilation of all mines.

**1072.** As previously explained, the weight of the **motive column** is the excess of weight producing a flow of air; hence, it is the algebraic sum of the weights of all the air columns, positive and negative. It is often convenient to reduce the various factors in any ventilation to a single *motive column*, which at once expresses the height of air column whose weight produces the ventilating pressure.

**1073.** An essential point, in regard to all air columns, is the *density* of the air which forms it. Whatever affects the density of the air affects the weight of the column. Temperature, pressure, moisture, presence of gases, all affect the weight of the air column, to a greater or less degree. In nice calculations, it would be right to consider all these factors for each column respectively. In ordinary calculations, however, it is customary to consider the temperature of the column and the barometric pressure only, ignoring the mine pressure, the amount of moisture in the air, and the presence of gases. The latter, excepting

moisture, are often very important factors. Mine pressure may affect the motive column to the amount of  $2\frac{1}{2}$  per cent., always increasing the density of the intake air. The presence of carbonic acid gas in the upcast current, or in the return current of any ascensional ventilation, acts to reduce the motive column, and may amount to as much as 20 per cent.

---

### THE BEST METHODS OF VENTILATING GASEOUS AND NON-GASEOUS MINES.

#### 1074. Ventilation of Flat, Non-Gaseous Seams.—

Fig. 177 shows a plan of underground workings in a non-gaseous mine, worked upon the pillar and chamber method. The seam lies flat, or nearly so. The main feature of the ventilation here shown is the manner of splitting the air at each pair of cross-entries, so as to give to each pair a separate current. Or, one split of the air may be made to ventilate two pairs of entries near the face of the workings. On account of the expense, overcasts are never put in at any pair of cross-entries until the development warrants the outlay. It is evident, from observing the plan, that each overcast saves either a door or a stopping, and always leaves the main road free of doors. It must be remembered, however, that the practical limit to splitting an air-current is the velocity of the divided current, which must not fall below 3 or 4 feet per second in non-gaseous mines, and 5 or 6 feet per second where gas is given off. For example, if the sectional areas of the airways are each, say, 50 square feet, and there is only 15,000 cubic feet of air passing upon the main airway, this current can not be split, as its velocity now is but 5 feet per second, and another split would reduce it below the limit.

1075. Another important feature, in the practical ventilation of a mine, is the location of the stables. They must be situated close to the bottom of the shaft, so that the mules can be easily rescued in case of accident, and where the daily feed and refuse can be readily handled. It

is also essential that they be ventilated by a separate split of fresh air, as shown in Fig. 177, and that the return

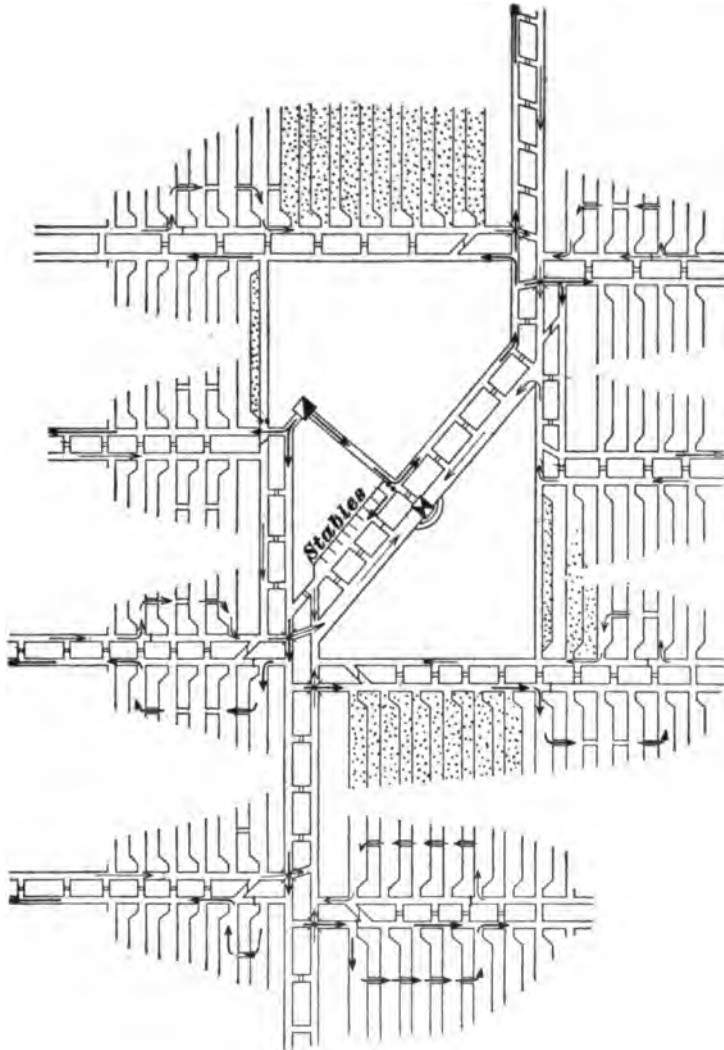

FIG. 177.

current from the stables should pass through a regulator, to prevent excessive drafts, and thence directly out to the

upcast shaft, and not contaminate the air of the mine by mixing with it. In Fig. 177 the feed and refuse are handled through the door shown in the first cross-cut, next to the shaft. The mules enter the stable at the other end, which requires no door.

**1076.** Another important feature to be considered, in the ventilation of all mines, is the arrangement of the haulage roads with respect to the air-currents. It will be observed in Fig. 177 that the main haulage roads are made the *return* airways of the mine. This is the better plan in all non-gaseous mines, for two principal reasons: (a) freedom from dust upon the *intake*; (b) freedom from ice in the hoisting shaft in winter.

**1077. Ventilation of Gaseous Seams.**—In gaseous mines, the haulage is always of necessity done in the intake airways, to lessen the liability of explosion. If the mine represented in Fig. 177 were gaseous, it would be necessary to reverse the current, and cause it to circulate in a direction opposite to that shown, making the *hoisting* shaft the *downcast*. This is usually done by means of an exhaust-fan placed at the mouth of the *upcast* shaft. The doors throughout the mine would all require to swing in the opposite direction, but in other respects the arrangements in the two cases are identical, except only in respect to the velocity of the current, as already explained.

In very fiery mines, the main roads, or gangways, are often driven triple instead of double. This method is called the "Triple Entry System," a section of which is shown in Fig. 178.

The middle entry is always made the intake and haulage road, the two outer entries being the return for each side of the mine, respectively. The *exhaustive* system of ventilation must be used in this case as in every other case where the *haulage road* is made the *intake*; otherwise, a door would have to be placed upon the haulage road, and there should then be two doors to prevent the stoppage of the current while the trip is passing. Such doors have been

introduced into the hoisting shafts in certain cases. They were made to work automatically and reciprocally, the one opening after the other had closed, each time the cage passed. This arrangement is complicated, and should never be used where it can be avoided.

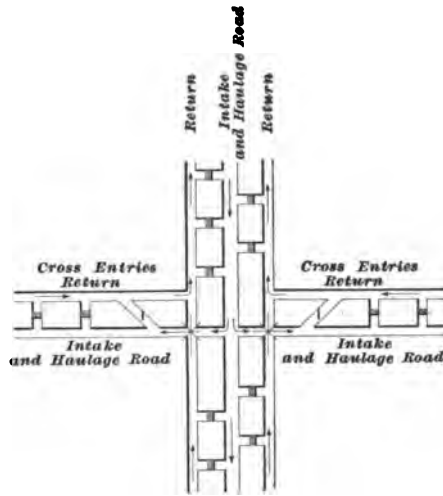

FIG. 178.

The chief advantage of the triple-entry system is that it furnishes a separate return for each side of the mine, and in case of an explosion, there is more complete isolation of the affected district.

**1078. Ventilation of Inclined Seams.**—The main point to be considered, in the ventilation of all inclined seams, is that it shall be *ascensional*. In other words, the *intake* air being, as a rule, cooler than that of the return, should be conducted at once to the lowest portion of the workings, whence, as it gradually absorbs heat from the mines, it tends to rise. The natural heat of the mine, as has been previously explained, always creates a small  *motive column*, which *assists* the ventilation when the cooler intake runs to the dip, and its return, to the rise. In general, the cool outside air *falls naturally* to the lowest place in the mine, and as it becomes heated in its passage through the workings, it *rises naturally* to the higher portions. As far as it is practicable to do so, this principle of ascensional ventilation must be applied in conducting an air-current through workings in an inclined seam.

**1079.** Fig. 179 shows the ventilation of the workings of an inclined seam opened by a slope. The *intake* is a



shallow shaft near the mouth of the slope, while the return is the main haulage road leading to the mouth of the slope. The first four pairs of entries, it will be observed, are ventilated by a separate split. Each of these splits is conducted through the lower entry of the pair, directly to the face of the entries, and after passing through the inside cross-cut, it enters the last room, being deflected, if necessary, by a canvas hung on the entry. The current traverses the working face of each room by passing through the cross-cuts in

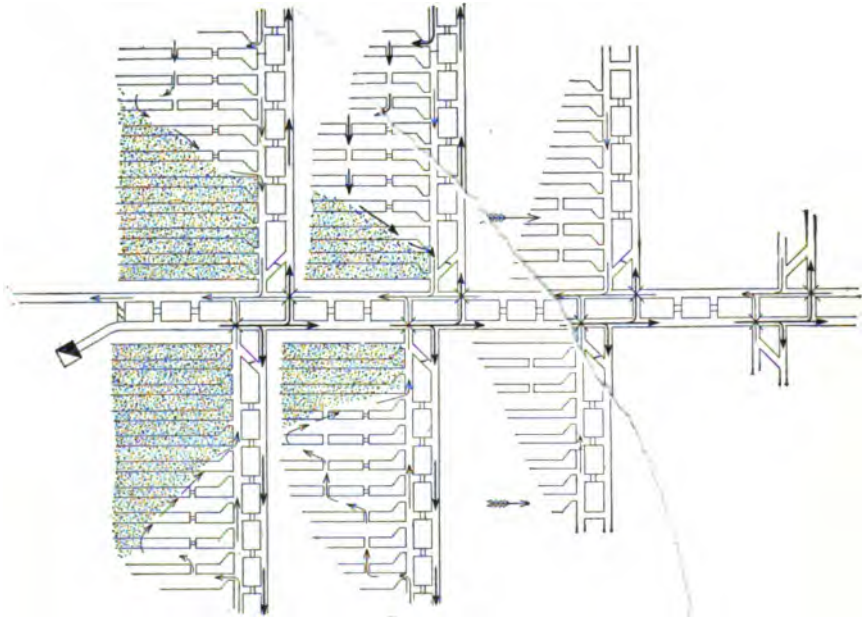

FIG. 179.

the room-pillars, and along the edge of the gob where the pillars are being drawn back.

If the seam represented in Fig. 179 were a gaseous seam, the direction of the current should be reversed, the main haulage roads being made the intake airways for each respective section of the mine. This is best done by making the fan at the air-shaft exhaust.

The types of ventilation, or the manner of conducting the air through a mine, illustrated in these general plans, cover

all cases of practical ventilation. The successful application of the principles involved in any one particular case will, however, often depend, owing to varying conditions, upon the skill and ingenuity of the man in charge.

**1080. Manner of Handling a Body of Gas.**—The removal of a body of gas that has accumulated in an idle room or unused chamber requires great precaution if the gas is fiery. This should never be attempted until all the men who are in the neighborhood of the outgoing air-current have been withdrawn. Brattices of canvas should then be so hung as to direct into the workings where the gas is lodged the main portion of the air traveling along the air-way. Or, if the gas has accumulated in some cavity of the roof, the current must be made to sweep this cavity by a brattice erected in the entry beneath it. Great care is necessary not to ignite the gas. Only the most reliable safety-lamps should be employed, and they should be placed in fresh air, at a safe distance away, and carefully watched.

The practice, already alluded to, of passing a gaseous current over a furnace by first diluting it with a sufficient quantity of fresh air direct from the downcast, is a dangerous one. Indeed, best mining practice to-day does not tolerate a furnace in a mine that yields gas.

**1081. Entrance of a Mine After an Explosion.**—This part of the subject will be considered only as it depends upon the restoration of the ventilating current in the air-ways and workings. The call for volunteers and their organization into two or three rescuing parties, each under its own efficient leader, is followed immediately by the adoption of such measures as a hasty examination shows to be necessary to restore ventilation.

If an exhaust-fan was in use at the mine opening previous to the explosion, it will generally be found to be less injured by the force of the explosion than would be the case with a blower-fan, depending, of course, upon the location of the initial explosions with respect to the upcast and downcast shafts. The force of an explosion is usually

exerted in the direction of the intake opening. Any injury to the fan that incapacitates it for use must be speedily remedied. The original course of the ventilating current should not be altered, except upon the most urgent demands.

As quickly as the intake current begins to enter the mine, the men should follow, equipped with good lamps, picks, shovels, saws, axes, sledges, brattice-cloth, and boards. They proceed at once to follow the air, rebuilding doors and stoppings or erecting a temporary line of brattice for conducting the air around a fall. The main point to be borne in mind is that no effectual advance can be made ahead of the air.

**1082. Mine Fires.**—This term applies to any form of slow or rapid combustion taking place in the passages or workings of a mine. Mine fires are a dangerous element in *any* mine. In gaseous mines in particular is this the case, the presence of a fire being an imminent source of peril.

The chief **causes** leading to mine fires are: (a) *spontaneous combustion*, as it is called, or combustion from natural causes, arising from the storing of slack and fine coal in the gob; (b) *ignition of the coal* by a gas-feeder fired by the flame of a blast; (c) *ignition of a door-frame, brattice, or timbers* by a naked lamp. Whatever the cause, a fire in the workings or passages of a mine should receive prompt attention. Its presence is manifested not more by the heat developed than by the peculiar odor imparted to the air.

**1083. Treatment of Mine Fires.**—The treatment of mine fires will be considered with particular reference to the ventilating current. The manner of treatment is divided into four classes, according to the stage of development the fire has reached, viz.:

(a) Direct method, with hose and water or portable chemical fire-extinguishers.

(b) Loading out in mine cars.

(c) Isolating from the air by special stoppings, so built as to effectually prevent air leakage.

(d) Flooding.

**1084.** In its incipient stages, a mine fire can be extinguished by the direct method, and a gob fire especially can readily be loaded out in mine cars; but it frequently happens that the fire assumes larger proportions before it is detected.

The first method of treatment is a simple one, and needs no explanation except to state that efficient chemical fire-extinguishers are on the market, and that the simple methods of operating them are fully explained by the manufacturers.

**1085.** When it becomes necessary to build stoppings for the isolation of a mine fire, much care is needed, both in the location of the stoppings and in the order in which they are erected. The places chosen as the locations of stoppings should be, as far as practicable, in the narrowest openings available in the solid coal. The affected area should be completely shut off and sealed to the access of air. The stoppings must be well built, and of the quickest available material. Care must always be taken to begin sealing off a fire at its side next the return air and work towards the intake, sealing the intake opening last. The reason for this is that, by closing the return-air side first, the gases set free by the fire drive back the fresh air after that stopping is made, and when the intake is properly closed there is no chance for imprisoned pure air to initiate an explosion. It also affords a better opportunity for the dilution of the gases with the air of the ventilating current. Care, however, must be taken to avoid breathing the carbonic oxide, or white damp, incident to mine fires, as it is the most poisonous gas known.

In a gaseous mine it would be unsafe to proceed in any other way than that above described. Violent explosions have been known to result from neglect of these precautions. From the moment of the sealing of the inlet end, if this end be sealed first, the gases generated by the fire, and

otherwise, increase in volume and move slowly towards the outlet, where they have free access to the airway in a dangerous form.

When these stoppings have remained closed for a sufficient period, and it is necessary, in order to work the coal, that they be opened, it must be done with the utmost caution, and in the reverse order to that in which they were sealed. The stopping at the intake end is thus the first one to be taken down, as it was the last one put up. Careful search must at once be made to discover any smouldering remains of the fire, and for days after the place must be closely watched.

**1086.** Flooding a mine, in order to extinguish a fire, is only considered as a last resort. At times, certain portions of the mine which alone are affected are shut off and flooded. It then becomes necessary to construct dams sufficiently strong to withstand the pressure due to the water. The construction of these dams is treated particularly in *Methods of Working*.

# ECONOMIC GEOLOGY OF COAL.

---

## SURFACE AND STRUCTURAL GEOLOGY.

---

### INTRODUCTION.

**1278. Economic Geology** is that department of natural science which treats of the structure of the earth's crust in its relation to its mineral products.

**1279.** The Economic Geology of Coal treats of the deposition, formation, and occurrence of coal, the shape and character of the coal deposits and their accompanying strata, and the nature and the history of the adjacent formations, as far as it will assist in mining.

It is as important that practical men should know what strata do *not* contain coal, as to know what strata do; therefore, we will briefly describe the formations below and above the coal measures.

**1280. Dynamic Geology** treats of the natural forces that operate in changing and modifying the structure of the earth's surface. These forces are known as *atmospheric, aqueous, igneous, and organic.*

**1281.** Atmospheric action disintegrates rocks and forms soil.

**1282.** Aqueous action, or the action of water, is either mechanical or chemical. Rivers, oceans, and ice exert mechanical force, and mineral waters cause chemical changes.

**1283.** Igneous action, or the action of heat, aids in the elevating of and the depressing of the sea bottom, and in the production of the inequalities of the earth's surface. All crust motion is due to the interior heat of the earth.

**1284.** Organic action was the cause of vegetable accumulations, forming coal and bitumen, and of animal accumulations, forming limestones.

**1285.** In Fig. 352 is shown an ideal section of the earth's crust. The references are as follows:

*A*, Recent Formations; *B*, Quaternary Formations;



FIG. 352.

*C*, Tertiary; *D*, Mesozoic; *E*, Carboniferous; *F*, Devonian; *G*, Silurian; *H*, Cambrian; *I*, Pre-Cambrian; *J*, Laurentian; *K*, Molten and Igneous Rocks. 1, Coral Reef; 2 and 3, Granite Intrusion; 4, Laccolite.

#### THE EARTH'S CRUST.

**1286.** The outer surface of the earth is a cool crust covering and enclosing incandescent matter in the interior. This crust consists of a solid structure with an irregular surface, consisting of mountains, plains, and valleys. The deepest depressions are filled with water and form the oceans and lakes.

**1287.** The mean temperature of the whole earth's surface is about 58° Fahrenheit, the northern hemisphere being about 60° Fahr., and the southern hemisphere 56° Fahr. There is in every locality a daily and an annual variation of temperature. The depth at which there is *no daily variation* is but a foot or two below the surface, but the depth of *invariable* temperature in temperate climates is about 60 or 70 feet. At the equator the depth of *invariable* temperature is only one or two feet from the surface. In high latitudes, approaching the poles, the depth of invariable temperature

increases and probably exceeds 100 feet. Beneath the depth of invariable temperature the temperature of the rocks increases for all depths to which it has been penetrated. This rate of increase, however, is not uniform in all localities. It is sometimes faster in one locality than in another, all depending on the conductivity of the rock penetrated. Observation has given us the fact of increase, but no law. The following formula gives results conformable with the general results of observations:

$$T = 50.68 + \frac{D - 19.68}{67.2}, \quad (83.)$$

where  $T$  = temperature in degrees Fahrenheit;  
 $D$  = depth penetrated.

The mean density, or specific gravity, of the earth, as a whole, has been determined by several different methods at about 5.6, considering the density of water as 1. The density of the materials forming the earth's surface, leaving out water, is not more than 2.5. It is evident, therefore, that the density of the central portion must be more than 5.6.

---

### STRATIFIED ROCKS.

**1288.** Stratified, or sedimentary, rocks consist, for the most part, of sand and mud thrown down originally either at the mouths of rivers along the sea-shore or in lakes. The materials vary greatly in degrees of fineness. The coarsest is a mass of rounded pebbles formed along a rocky shore. When these shingle pebbles are cemented together by a fine material they form conglomerate. Sand beds are composed of minute, loose, angular stones, accumulated before their corners were rounded. Gravel consists of loose rounded stones, or pebbles. Breccia consists of angular stones consolidated.

Stratified rocks are of three kinds, *arenaceous*, *argillaceous*, and *calcareous*, and a fourth, *organic*, may reasonably be added.

**1289.** **Arenaceous** rocks, in their incoherent state, are sand, gravel, shingle, rubble, etc., and in their



compacted state, are sandstones, gritstone, conglomerates, and breccia.

**1290. Argillaceous** rocks, in their incoherent state, are muds and clays. When partly consolidated and finely laminated, these muds and clays form shales. When fully consolidated and laminated, they form slates.

**1291. Calcareous** rocks are chalk, limestone, and marble. They are seldom in an incoherent state, except as chalk. Limestones were formed by deposits in lakes or seas, and are the powdered remains of shells, corals, fish, sponges, etc., consolidated in a coherent mass. They are, therefore, organic sediment.

Calcareous rocks deposited by chemical action are due to the fact that water can keep carbonate of lime dissolved only as long as it contains carbonic acid dissolved in it as well. When such water emerges into the air it loses some of its carbonic acid, and is unable to retain the lime in solution, which is then deposited.

Nearly all the limestones, all the coal, and some silicious beds are composed of stony relics of either plant or animal life.

**1292.** The calcareous materials, or the constituents of lime, come mostly from:

1. Shells of mollusks, or animals of the oyster, clam, or mussel type.
2. Corals, or the secretions of marine animals of a lower grade than vertebrates.
3. Crinoids, a family of marine animals of the nature of star fish.
4. Calcareous shells of rhizopods, corallines, coccoliths, and rhabdoliths, marine animals of the lowest order, known as Foraminifera.

When the above animal life in the sea was profuse, limestones were formed.

The rhizopods, or the organic remains of shells, or corals, or crinoids, probably made the limestones of the Paleozoic

era. If rhizopods enter largely into the formation, the limestones were probably accumulated in deep water.

**1293.** The conditions necessary for the growth of reef-building corals are: the temperature must be mostly that of the Torrid Zone; the depth of water must not exceed 100 feet; the water must be salt and clear, and the corals must be freely exposed to waves. Since corals can not grow in waters more than 100 feet deep, it is evident that subsidence keeps pace with the growth of the corals; otherwise, it is impossible to account for the enormous thickness of coral reefs. However, there is no evidence of subsidence on the coast or keys of Florida, and it is therefore supposed that the Florida reefs were formed partly by organic sediment brought by the Gulf Stream from other coral banks in the Caribbean Sea, but mostly built up by the accumulation of shells of successive generations of deep-sea animals, the Gulf Stream contributing only the conditions necessary to rapid growth, warmth, and food.

**1294.** Shallow water deposits of molluscous shells are made principally by mollusks living in great numbers near the shore, and on submarine banks. They left their shells generation after generation, sometimes forming pure shell deposits, and sometimes shells mingled with sediments due to other agencies.

**1295.** Over nearly all the bottoms of deep seas, at depths at which sedimentary deposits are impossible, we find a deposit of carbonate of lime, shells of foraminifers, and coccospheres of microscopic plants. Chemical and microscopic examinations of these deposits lead to the belief that chalk was formed in this manner.

The formation of limestones from shells or crinoidal remains is similar to that from corals, the waves wearing them, or part of them, to mud, when consolidation takes place. The rate of formation of limestones from shells is slower than that of coral or crinoidal limestone, since the calcareous secretions of mollusks contain, proportionately, much less carbonate of lime.

**1296.** These arenaceous, argillaceous, calcareous, and organic materials, or sands, clays, lime, and vegetable matter, may gradually combine with each other to form the argillaceous sandstones, calcareous sandstones, calcareous shales, marl, and organic shales.

There is abundant and conclusive evidence that stratified rocks are more or less consolidated sediments. Beds of clay and mud, and sand, may be traced, by almost insensible gradation, into shale and sandstone.

The cementing material, such as carbonate of lime, silica, or oxide of iron, present in percolating water, accounts for the consolidation of sediments into rocks.

In many cases rocks have been deposited with extreme slowness. In proof of this statement, shales are found the lamination of which is beautifully distinct, although each lamina is no thicker than cardboard. Each lamina was separately formed by alternating conditions, such as the rising and falling of tides or the flood and fall of rivers.

**1297.** Stratified rock must have been originally nearly horizontal, as such a position would naturally be assumed by all sediment in obedience to the law of gravity. It may,

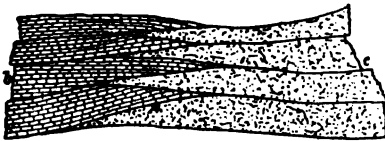

FIG. 353.

therefore, be assumed that highly inclined or folded strata have been changed since first deposited and consolidated. The planes separating strata were not originally all horizontal, nor was each stratum always of uniform thickness. Each stratum, when deposited, should be regarded as a widely expanded cake, thickest in the middle and thinning out at the edges, and interlapping there with similar cakes. In Fig. 353, *c* is sandstone and conglomerate, and *b* is limestone.

In fine materials, strata assume the form of extensive thin sheets, while coarse materials thin out more rapidly, and are more local.

The oblique lamination is a most important exception to the law of horizontality, and is considered a phenomenon.

Oblique lamination is due to rapidly shifting currents bearing lots of coarse materials, or to chafing of waves on an exposed beach. Fig. 354 is an example.

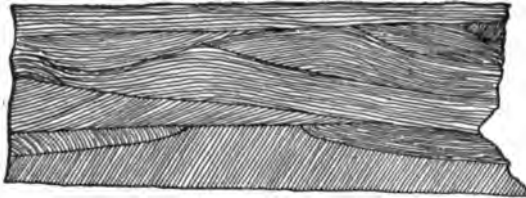

FIG. 354.

**1298. Elevated, Inclined, and Folded Strata.**—

Assuming that stratified rocks were deposited as sediment at the bottom of water in a nearly horizontal position, it is evident that some great force has been at work changing the position of the rocks composing the earth's crust. These rocks are found in the vicinity of the oceans, but more often in the interior of the continents, high up on the mountains; sometimes they are horizontal, though high up; sometimes the strata at this elevation are still soft, but, as a rule, of a stony nature. In the mountain regions the strata are tilted at all angles, folded, contorted, overturned, broken, and slipped, so that it is difficult, in many instances, to determine their original order of superposition.



FIG. 355.

The outlying coal fields of Western Pennsylvania show clearly how strata, high up in the mountains, are found in a nearly horizontal position. (See Fig. 355.)

**1299. Dip and Strike.**—The dip of strata is their inclination from a horizontal plane. Fig. 356 shows strata dipping southward about  $45^\circ$ . The angle of dip is measured by a clinometer, and the direction of dip by a compass. The two instruments are often conveniently combined in one.

The strike of strata is the line of intersection of the strata with a horizontal plane. It is always at right angles to the

dip. In Fig. 356, the line  $b c$  shows the thickness of the



FIG. 356.

strata. The thickness  $b c = \text{distance } a b \times \sin 45^\circ$ , provided the strata are free from troubles.

With a disturbance of the strata, as shown in Fig. 357, no rule can be given with which to calculate their thickness. If the dip is known, the strike is also known; but if the

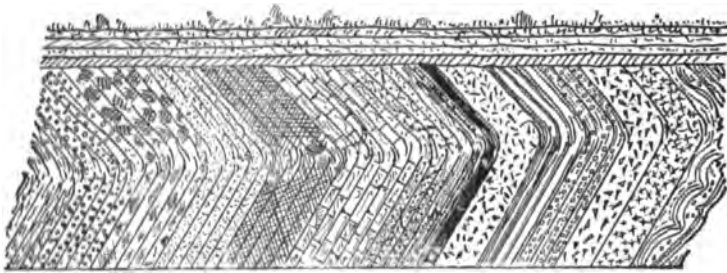

FIG. 357.

strike is given, the dip can not be known from it, because the dip may be inclined to either side of the strike. For example, if the strike is due east and west, the dip may be either north or south.

**1300. Anticline, Syncline, Monocline, Pericline, Escarpment, and Outcrop.**—When strata dip in opposite directions from a ridge, or line of elevation, the ridge so formed is called an anticline, or saddle-back, and the line of elevation is termed the **anticlinal axis**, as at  $a$ , Fig. 358. When strata dip towards a common line of depression, as at  $b$ , the axis is said to be **synclinal**, and the depression so made is spoken of as a **syncline trough**, or **basin**.

Synclinals may be found without anticlinals, and anticlinals may be found without synclinals. Anticlinals may

be found directly over synclinals, and there may be a number of anticlinals and synclinals within one great synclinal.

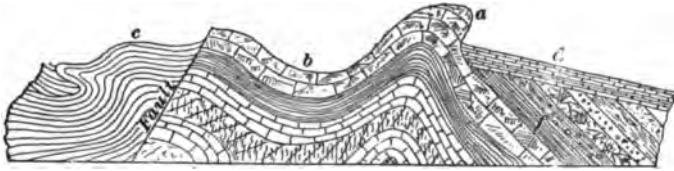

FIG. 358.

Fig. 359 shows a section across the entire region of the anthracite coal field of Pennsylvania, which is an excellent example of these conditions. Each separate division, or basin, is a syncline within a larger syncline, and each division is again subdivided into still smaller synclines, or basins.

Anticlinals do not always form the higher ground, as might at first be supposed, but frequently form the bottoms of the valleys, while the synclinals are found in the hills.

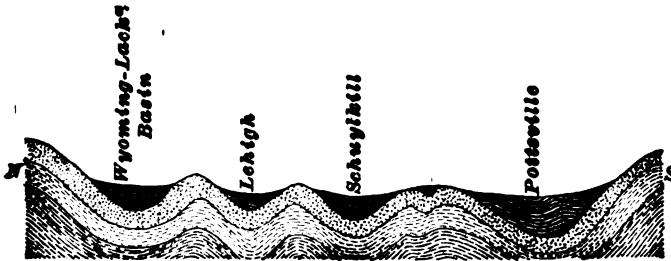

FIG. 359.

The Pittsburgh region is also traversed by a system of low or very flat anticlines and intermediate synclines, whose axes bear in the same general direction as the anthracite basins and saddles do, namely, N E and S W. The Connellsville coal field is the most easterly of the synclinal basins in the Pittsburgh region.

**1301.** The strata are said to be **monoclinal** when, though lying at different angles, they all dip in the same direction, as at *a b*, Fig. 360; **periclinal**, when they dip in every direction from a common center like a cone.

When strata terminate abruptly in a bold, bluff edge, they form an **escarpment**.

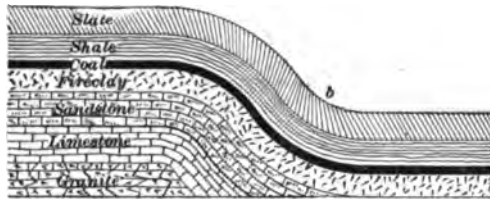

FIG. 360.

When any strata can be seen at the surface, the exposure is called the **outcrop**.

**1302. Conformity and Unconformity.**—When strata lie upon each other in parallel order, as at *d*, Fig. 358, they are termed **conformable**; but when one set inclines upon another at a different angle, they are termed **unconformable**. (See *d* and *f*, Fig. 358.) When strata are bent and twisted, they are termed contorted. (See *c*, Fig. 358.)

**1303. Geological Formation.**—A group of strata conformable throughout and containing similar fossils or organic remains, and separated from other conformable groups by a line of unconformable rocks, is called a **geological formation**.

**1304. Concretions.**—There is a chemical process common in stratified rocks which results in the formation of **nodules**, or **concretions**. For example, the flint nodules in chalk are due to the presence, among the chalk, of small shells, sponges, etc., which were chemically acted upon by percolating water and formed into flint nodules.

In many stratified rocks, nodules of various kinds are found, scattered through the mass, or in layers, parallel to the planes of stratification, or in groups, sometimes so thickly deposited as to form local patches of stone or gravel beds. The structure, like slaty cleavage, is the result of internal changes subsequent to the sedimentation, for the planes of stratification frequently pass through the nodules. The clay iron-stone nodules of the coal strata are familiar illustrations of this structure.

These nodules, or concretions, take quite a variety of shapes and are of all sizes up to many tons in weight. They frequently have a network of cracks inside, which may be

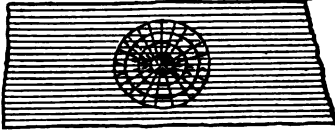

FIG. 361.



FIG. 362.

filled with different minerals. In coal beds, they are the nigger-heads and sulphur balls. In shales, there may be nodules of siderite or clay iron-stone. In limestone, the nodules are always silica. In sandstone strata, the nodules are commonly carbonate of lime or oxide of iron—lime or iron balls (Figs. 361 and 362).

The bending up and down of strata, quite locally, is sometimes due to the presence of large concretions, which, in process of formation, seem to have swelled the strata or pushed them away. (See Fig. 363.)

During the formation of coal, stumps and logs were floated off into lakes, to sink and become buried in the accumulating vegetable débris, or in deposits of detritus, and some of these stumps may have carried large stones which they finally dropped and so put an occasional "boulder" into the forming beds. These boulders must not be confounded with concretions.



FIG. 363.

### ORIGIN AND DISTRIBUTION OF FOSSILS.

**1305.** Shells were imbedded in shore deposits, leaves and logs of high land plants and bones of land animals were drifted into swamps and buried in mud, and tracks were formed on flat muddy shores by animals walking on them. These have been preserved with more or less change. They are called **fossils**. There are multitudes of different fossils scattered through all the stratified rocks, but every group of rocks carries its own peculiar fossils, so that from the knowledge of them the truest key to the different formations is placed within our reach.



The best way to study the characteristic fossils of the various formations in which coal beds are known to occur is to visit any public or private collections within reach.

A study of the illustrations in this subject, and in other well-illustrated geological manuals, will greatly assist the student in familiarizing himself with the most common forms of fossils.

**1306. Geological Fauna and Flora.**—Generally speaking, the various animals belonging to the world constitute the geological fauna, and the plants and trees constitute the geological flora. Nearly every era, age, period, and epoch has a fauna and flora which have a marked distinction from those of other eras, ages, periods, and epochs.

**1307. The Order of Superposition.**—The order of superposition, and, therefore, the relative ages of the strata composing the rock series, were determined:

1. Independently.
2. By comparison, partly by the minerals and character of the rock (if the localities were contiguous), and partly by fossils.

In this way the geologist determines which strata in various localities were formed during the same period, and which strata are missing in some localities. In the widely separated districts, the comparison can be made only by fossils.

An indefinite number of limestones, sandstones, shales, and conglomerates are included in the stratified rocks of the earth's crust. They occur horizontally and displaced, conformable and unconformable. Even the same bed frequently changes its character in a very short distance from a sandstone to a shale, from a shale to a limestone or a conglomerate. Again, if it retains a uniform composition the color changes, so that it can not be recognized by appearance.

The sandstone of one district may be represented in another by a limestone of contemporaneous origin. Some rocks are found in the east of the United States which are not found in the west in the same age.





Sand beds, mud beds, clay beds, pebble beds, and limestone beds all over different parts of the globe may have been forming during the same geological era.

A stratum of one age may rest upon any stratum in the whole series below it. For example, the coal measures may rest on the Archean, Silurian, or Devonian, and the Jurassic, Cretaceous, or Tertiary on any one of the earlier strata, the intermediate strata being entirely wanting.

The second object to be attained by classification is the division and subdivision of the whole series into larger and smaller groups, corresponding to eras, periods, and epochs of time.

The Geological Chart for North America gives an outline of the classification referred to. This classification is very important in the study of the Economic Geology of Coal.

#### UNSTRATIFIED, OR IGNEOUS, ROCKS.

**1308. Igneous Rocks**, which form the second class, are much more complex in structure and composition than aqueous, or stratified, rocks. They contain a great variety of minerals, and the minerals themselves are of great complexity. They are distinguished from stratified rocks by the absence of true stratification, by the absence of fossils, and by the difference in the mode of their occurrence. They are due to heat in some form.

**1309.** Igneous rocks occur underlying all the strata (see *K*, Fig. 352), forming the axes and peaks of nearly all

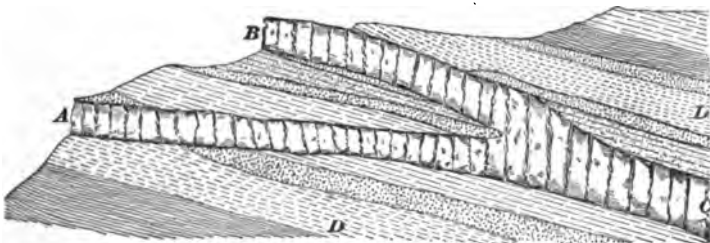

FIG. 364.

great mountain ranges (*J*, Fig. 352). They also occur in

vertical or nearly vertical sheets, filling great fissures in stratified rocks or other igneous rocks. Fig. 364 shows *A B C* cutting strata between *D D*, and is called intrusive. In Fig. 352, 2 shows a granite intrusion which, if it continued its outpour, would form a horizontal sheet overlying the strata *G*. When such intrusions, or dykes, cut coal seams they partially coke the coal (sometimes burn the coal completely, leaving only the ash), and bake the measures where they have come in contact with them.

**1310.** Igneous rocks may be classified as volcanic and plutonic. Most, but not all, volcanic rocks are recent. A volcano is simply a hole in the earth from which materials (gases, liquids, and solids) are at times expelled and scattered around the opening. (See Fig. 365.)

From the opening called the crater, masses of rock, torn



FIG. 365.

from the side, are hurled with the steam into the air; these strike against each other and, falling and being again ejected, are reduced to dust; this dust, with the coarser material, is often converted by rain into a mud, which is known as volcanic ash. This ash is spread in a more or less stratified manner; sometimes when it falls into the sea it is perfectly stratified, and may be mixed with various marine sedimentary matters, and may even contain fossils. Nevertheless it is proper to classify it as igneous rock.

If the cross-section of a volcano could be seen it would appear something like that shown in Fig. 366.

*A, A, A, A* are successive layers of lava and ashes

thrown up from below, at various stages of activity of the volcano. *V, V'* is what is called the *neck*, i. e., the crack or hole through which the materials of the volcanic mass have

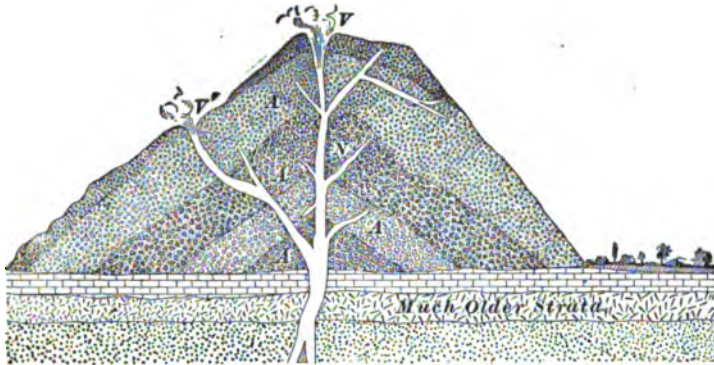

FIG. 366.

been ejected. This neck may have several branches, as shown, and from these, little volcanoes such as *V'* are often formed and become "active" at various periods.

**1311. Lava** produced by volcanoes is molten, or semi-molten, rocky material containing a large amount of water, which escapes from it in the shape of steam, filling the upper part of the stream of lava with bubbles and rendering it *light and cindery*. As it cools, it becomes very hard in the central portion, and sometimes a peculiar col-

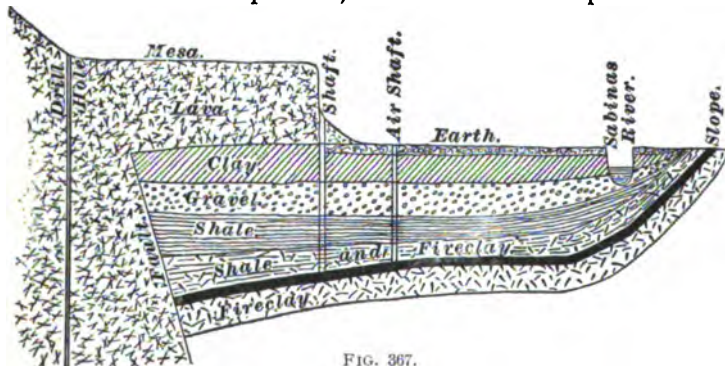

FIG. 367.

umnar appearance is developed by contraction in the act of cooling.

Sometimes the lava, instead of being poured out at the crater, or neck, is forced into and through the surrounding strata, either filling cracks and joints and forming *dykes*, or, in some cases, forcing itself in between two layers of rock and producing the appearance of having been *interbedded*.

Sometimes coal is found extending to a great length under a deposit of lava, as in Mexico. The lava which formed the Santa Rosa Mountains was thrown up and flowed over the strata containing the coal to a great distance from the point where the lava was pushed up through the coal and other soft strata. (See Fig. 367.)

**1312. Plutonic Rocks.**—There is no essential difference in composition between plutonic rock and volcanic rock. The difference is in texture. Plutonic rocks cooled and solidified at considerable depth in the earth; and, naturally, the cooling process went on more slowly, and the mineral materials were able to arrange themselves in a more or less crystalline form. The best known and most marked in character of this group are the granites and their allies.

---

### METAMORPHIC ROCKS.

**1313.** All rocks have been changed, or metamorphosed, to some extent since their original deposition, but the term metamorphic applies only to those rocks which have been changed into crystalline rock, and, usually, without fusion. The rocks so changed were the ordinary fragmental rocks and limestones. The alteration, when most perfect, has consisted in a complete crystallization of the rock, and when least so, in its consolidation; between these extremes various conditions of partial metamorphism exist. Examples of metamorphic rocks are marble, mica schist, serpentine, gneiss, and much granite. All the lowest and oldest rocks are metamorphic. However, metamorphic rocks are not always among the oldest; metamorphism is no test of age. Metamorphic rocks are found in the Tertiary formations as well as in the Laurentian. Metamorphism is generally

associated with foldings, tiltings, intersecting dykes, and other evidences of igneous agency, and is, therefore, found in mountainous regions. It is also usually found in very thick strata.

**1314. Effect of Metamorphism.**—The effects of metamorphism include:

1. Simple compacting and solidifying, as in making a rock looking like granite from granitic sandstone.

2. A change of color, as the gray and black of common limestone to the white color or the clouded shadings of marble, and the brown and yellowish-brown of some sandstones, colored by iron, to red, making red sandstone and jasper rock.

3. In most but not all cases, a partial or complete expulsion of water; serpentine contains 13% of water.

4. An evolving and expelling of oil or gas, as when bituminous coal is changed to anthracite or to graphite.

5. An obliteration of all fossils, or, if the metamorphism is partial, of nearly all. The obliteration is usually preceded by the compression and distortion of the fossils.

6. Often a change in crystallization with little or none in chemical constitution, as when a limestone is turned to white statuary marble, and a sandstone or argillaceous rock, made from the granulation of granite, gneiss, and related rocks, is changed to granite or gneiss again.

7. In many cases a change of constitution, for the ingredients subjected to the metamorphic process often enter into new combinations, as a limestone with its impurities of clay, sand, phosphate, and fluorides, under the action of heat, forms white granular limestone, with various crystalline minerals disseminated through it, such as mica, feldspar, scapolite, pyroxene, apatite, etc.

**1315. Theory of Metamorphism.**—The subject of metamorphism is a very obscure one, but it may be divided into two kinds, viz., local and general.

Mechanical energy can be converted into heat. If a piece



of cold iron placed on an anvil is struck with a heavy hammer it becomes hot; the mechanical energy of the moving hammer disappears, and at the same time instant heat is developed. There is a direct relation between the heat manifested and the mechanical energy which disappears. The heat is produced in the iron by its sudden compression, and in the same manner when a great mass of strata sinks down by its own weight, the lateral pressure, which throws it into folds, also develops a very great amount of heat. This heat combined with water and great pressure probably brings about those changes in the rocks called metamorphism.

Local metamorphism is produced by direct contact with evident sources of intense heat, as when dykes break through stratified rock. Under these circumstances impure sandstones are changed into schists or gneiss, clays into slates, limestone into marble, and bituminous coal into coke, anthracite, or graphite. Near dykes of trap the rock is sometimes made cellular by escaping steam and filled with fissures, made by shrinking on cooling or drying. The waters of mineral springs, especially when heated, have produced metamorphic effects in the rock.

### STRUCTURE COMMON TO ALL ROCKS.

**1316.** All rocks, whether stratified or igneous, are divided by cracks or division planes in three directions into

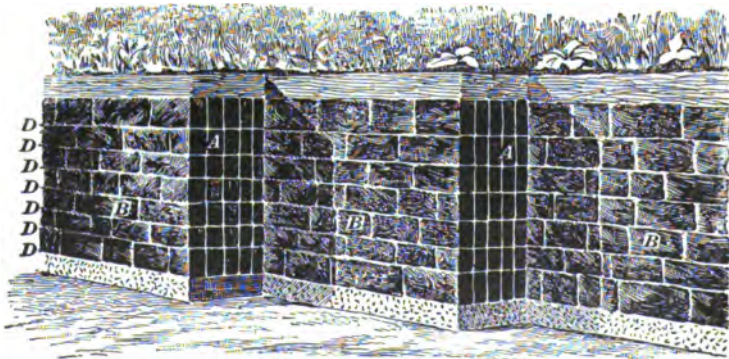

FIG. 368.

separate irregular prismatic blocks of various sizes and

shapes. These cracks are called **joints**. In stratified rocks the plane between the bedding constitutes one of the three division planes, which is called the **bedding plane**, while the other two are nearly at right angles to the bedding plane and to each other. They are true joints, sometimes called slips, and are known among mining men as **butt cleat** and **face cleat**. In some stratified rocks one of these last joints is well defined while the other may be rather irregular. In Fig. 368 the face cleat is shown at *A*, the butt, or end, cleat at *B*, and the bedding planes at *D*.

Fig. 369 shows slips, or cleats, as they appear in different coals. They are:

- (a) Inclined cleavage;
- (b) vertical cleavage;
- (c) irregular cleavage;
- (d) rhomboidal cleavage;
- (e) cone-in-cone cleavage;
- (f) shelly cleavage.

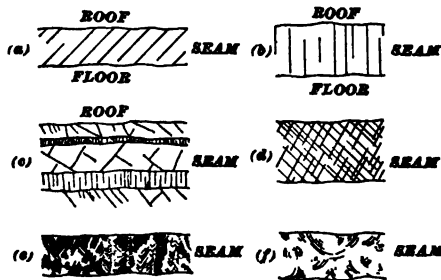

FIG. 369.

In sandstone, the blocks formed by these

joints are large and irregularly prismatic; in slate, small, confusedly rhomboidal; in shale, long, parallel, straight; in limestone, large, regular, cubic.

In stratified rocks, these joints are all probably due to shrinkage in the act of consolidating from sediments, and in metamorphic rocks to shrinkage in cooling.

Fissures and fractures must not be confounded with joints; fissures are fractures in the earth's crust passing through several strata, instead of but one, as in the case of joints. Joints were probably produced by shrinkage and other causes, but fissures were produced by movements of the earth's crust.

**1317. Cleavage.**—Cleavage, in geology, has a different meaning from joints. Dana says: "Slates are often transverse to the bedding, that is, they often cross the layers of stratification more or less obliquely, instead of conforming to the layers, or bedding. Cleavage is, in this

respect, like the jointed structure, but it has the planes of fracture, or divisional planes, so numerous that the rock divides into slates instead of blocks, and the two differ in mode of origin."

Cleavage has been proved by experiments to result whenever fine-grained rock material is subjected to pressure, and to be due to the flattening of all air cells and compressible particles, and the arranging of all flat grains in planes at right angles to the pressure. The pressure producing upturning, or flexure, and also mountain making, has generally been the cause of cleavage in upturned or flexed strata of fine grain. It conforms to the bedding whenever the bedding is, as a consequence of the upturning, at right angles, or nearly so, to the pressure.

Flagstone, or lamination cleavage, crystalline cleavage, and organic cleavage are readily defined, but the remarkable cleavage we have been discussing has long excited the interest of geologists, and many theories have been advanced.

---

#### FAULTS.

**1318.** The dislocations produced in the earth's crust by the numerous agents are known by such terms as **faults, slips, hitches, heaves, wants, leaps, throws, troubles**, etc. Faults may be so thin as to be mistaken for the ordinary jointing of the rocks they traverse. More often, however, there is a considerable space between their walls, or cheeks. This space is sometimes filled with débris from the adjoining rocks, or with matter deposited from the solutions circulating within them. When filled up with injections, or intrusive matter, or infiltration of mineral matter, the dislocations are known as dykes, lodes, and veins.

These disturbances, where they traverse the coal measures, contain Carboniferous matter, which at times is accompanied by metallic minerals. There is no essential difference between faults found in the coal measures and the mineral veins of metalliferous districts.

**1319.** In the making of faults (*AH, JI*, Fig. 370), there is first a fracture, and then a shoving up or down of the beds

on one side of the fracture; i. e., a **down-throw** on one side, or an **up-throw** on the other. The amount of dis-

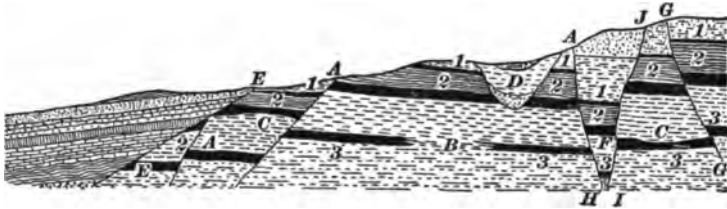

FIG. 370.

placement is the amount of fault; it may be a foot or less, or 10,000 feet or more.

**1320.** The position of a fault is defined by two directions; the strike of a fault is spoken of in the same sense as referred to beds, but in place of the word dip as referred to bed, in connection with faults the term **hade** is employed, this being, however, the inclination measured from the vertical. To determine a fault accurately two things must be known: 1. Which side is thrown up and which side is thrown down. 2. The amount of displacement. The former is in a majority of instances easily determined, as faults usually hade, or incline, towards the down-throw, so that in driving roads underground, if the fault is first met with in the roof, it is a down-throw, while if encountered on the floor first, it is an up-throw. Rock before breaking bends a little, and such signs are very useful to mining men, especially where the hade is nearly vertical; because if the coal turns upwards, it indicates an up-throw, but if the coal turns downwards, it indicates a down-throw. This is not, however, an invariable rule, for occasionally we find in the various coal fields, coal rising towards a down-throw, and *vice versa*. No rule can give the amount of displacement, as sometimes when the hade is small, the throw is large, and at other times with a similar hade, the displacement is very small. The throw of a fault is always measured vertically, and may be variable at different points, often changing from one foot at one end to hundreds of feet at the other.

When there is a lateral or oblique shove in a dislocation, as is often the case, the thickness of the bed on the two sides of the line of fault may differ; provided, the bed is not of uniform thickness throughout.

**1321.** The following definitions refer to Fig. 370:

(A) **Dislocations**, commonly termed "throws," "hitches," "slips," "jumps," &c., the amount of throw or displacement varying from a few inches to thousands of feet; that is to say, if in working a coal seam a nearly vertical wall of some other rock (other than a "clay vein") is met, it is possible that the coal bed has been faulted or thrown up or down to the extent mentioned.

(B) **Thinning out**; i. e., the stratum more or less suddenly thins down or becomes worthless as a mineral, due to one or more bands or seams of foreign material setting in and spoiling it.

(C) **Nips, rolls, horses**, mean that the roof comes down and takes the place of the coal, or the floor comes up and does the same thing—in some cases, both phenomena occur together.

(D) **Washouts, wants**, have practically the same effect upon the seam being worked, but have been produced by the removal or washing away of a portion of the seam, and the deposition in its place of sand or mud, afterwards converted into sandstone and shale. Washouts may affect more than one seam.

(E) **Denudation**.—This means that the seam, being followed, comes to an end against the surface or "modern" formations, or against stratified or unstratified rocks of some other period.

(F) **Trough Fault**.—A wedge-shaped fault, or, more correctly, a mass of rock, coal, etc., let down between two faults of dislocation dipping towards each other. These faults, however, are not necessarily of equal throw.

(G) **Overlap Fault**.—A peculiar kind of fault where a seam is reversed or doubles back over itself, as when one

end of the dislocation is thrust or forced over the other end.  
(See Fig. 371.)



FIG. 371.

**1322.** These faults have been produced or formed in several ways or through several agencies. The throws *A, A, G*, Fig. 370, show that the whole series of strata affected has been rent asunder and upheaved, then fallen back and become as one solid mass again, the ends of the seams on right of *G*, *G* having been forced over the broken ends on the opposite side of the line of fracture, whereas the throw or slip at *A* shows that the beds on the left have slid downwards on that side.

**1323. Clay Veins.**—Clay veins may be termed faults, inasmuch as they break the regularity of the coal seams they traverse, and more or less spoil their quality. Such faults are merely clay-filled gashes or wide cracks formed by considerable movement of the seam soon after it was deposited.

**1324. Wants or Washouts.**—Since wants are usually filled in with irregularly stratified materials, they can usually be distinguished from dislocations, or throws, and by drifting through this body of mixed measures on the same pitch as the coal lay before the washout took place, the seam will generally be recovered without any difficulty.

“Pinch out” is a term used by American miners very much, and signifies the same thing as *nip*. In some coal fields, especially the lower coal seams of Tennessee, the coals pinch out, leaving sometimes the thinnest streak of black between sandstones by which the seam is traced to the next *pocket* or *basin*. The term *squeeze* is sometimes used in the same sense as pinch out.

*Pennine fault* is used to designate the eroded crest of an anticlinal axis, or saddle.

**1325. Denudation** means the wearing and carrying away of the solid materials of the land by wind and water. Rivers carry away portions of the land through which they flow; the tidal currents of the ocean lay bare the rocky materials of its shores.

The glacier has also been a great agent of denudation, for, as it moved, it cut great furrows, or valleys, in the earth and carried on its under side large masses of loose material, which it deposited miles away from the place of their origin.

Denudation is going on constantly, not only in the tremendous rending and grinding of the tidal waves, but in the rivers and streams as well. Their turbidity testifies that they are tearing down and carrying to the valleys the materials of the high lands.

Water acts chemically on limestones, and eats away this rock. The feldspar of granite and basalt generally contains potash, soda, or lime, which is attacked by the carbonic acid and converted into carbonate of potash, soda, or lime, and is carried away in solution.

Changes of temperature in the air cause rocks to split into many pieces; heat causes rocks to expand, and cold causes them to contract, and as the outside of the rock experiences the greatest change it splits off from the inner part. This disintegration produced by frost and grinding of boulders furnishes much of the material carried by running waters, and deposited to form new rocks under the waters of the sea.

Wind also performs a portion of denudation by blowing sand in arid and sandy regions, which cuts away exposed rocks and planes them down in no small degree.

The manner in which the strata outcrop in the coal regions may be said to be due to denudation.

**1326.** Complexities in stratified deposits are often due to denudation; strata are removed over extensive regions, the top or side folds are carried away, and various kinds of sections made of the stratified beds.

One of the simplest of these effects is the entire removal of the rock over more or less wide intervals (Figs. 355 and 372), so that the continuation of the strata is met with many miles distant. The result is more troublesome among the flexed, or folded, strata.

A series of close flexures, like (a), Fig. 372, worn off at the top down to the level of the line *a b*, loses all appearance of folds, and seems like a series of layers dipping in one direction. This is best seen from a single fold as (b), Fig. 372. If the top of the fold (b) were cut off at the line *a b*, there would remain the part represented in (c), in which there is

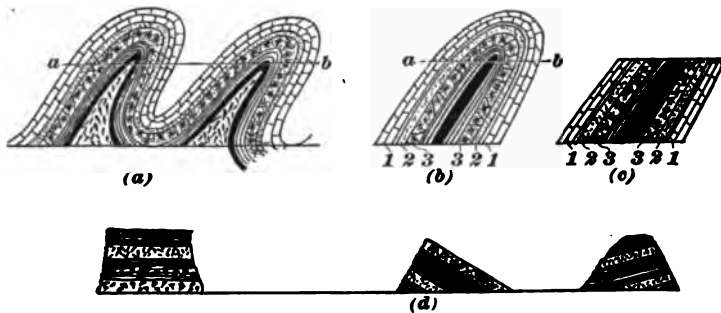

FIG. 372.

no appearance of any fold, and only a uniform series of dips. Although 3, 2, and 1 appear to be the lower strata of the series, they are actually parts 1, 2, and 3. A long series of such folds, pressed together and then denuded, would make a series of uniform dips, obscuring wholly the true stratification.

This obscuring of the true succession has been greatly increased by denudation over great areas and filling up of



intermediate depressions by soil, so that the rocks are visible only at long intervals, as in (*d*), Fig. 372. Many of the difficulties in the study of rocks arise from this cause.

**1327.** In coal mining, the work of denudation is seen in wants or wash-faults, "pot-holes," etc. The latter (pot-holes) are deep hollows or excavations in the rocks, made by the grinding action of hard boulders agitated by turbulent water in the glacial period. Since formed, they have become filled in with stones, sand, and mud, and may be beneath rivers and lakes; hence the results of denudation sometimes seriously affect coal mining operations in an unexpected way. (Nanticoke, Pa., disaster in 1885.)

Denudation then is the opposite of deposition, but as deposition somewhere must go on at an equal pace with denudation there is no actual loss or waste of matter; it is simply the process of moving material from one place to another—tearing down one kind of rock to build up one of a totally different kind in a different locality.

**1328.** Another result or effect of denudation is that the accumulation of strata, composed of denuded older rocks, causes subsidence of the original crust over the area on which such new strata are deposited, and a corresponding elevation of the area denuded.

Applying this principle to mining, we may assume that the roof will cave in sooner, or to a greater extent, if a heavy culm pile exists over the worked area than if no culm were there to add to the weight. And where the floor is soft when the coal is removed, the bottom will rise, because the weight has been taken off it.

It does not follow that because a lower coal seam has been denuded locally, overlying ones will be similarly affected. This will usually depend upon what the want is filled up with; if with coal-measure material, then the upper seam will probably remain intact—undisturbed; but if sand, gravel, boulders, clay, etc., are there, the chances are the top coal is not there.

Extremely rare instances are on record of coal seams being denuded from underneath. Fig. 373 will illustrate what is meant.

In Belgium there are quite a number of open or empty pits, or a very deep kind of pot-holes traversing the coal measures, but they do not always extend upwards to the surface or even to the highest stratum of the coal measures.

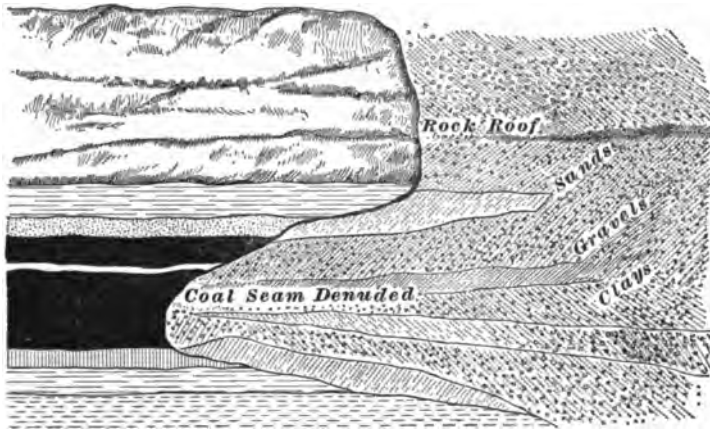

FIG. 373.

Some form of denudation would seem to have produced them.

**1329. Thinning Away of Strata—Overlap.**—It sometimes happens that two lines of outcrop come together, owing to the complete thinning away of the intermediate strata, and the conjoined outcrops may then be traceable for a long distance without further change. Instances of this kind sometimes occur among coal seams.

When the sea encroaches on the land, wearing away the cliffs and spreading out their waste materials in the form of shingle and sand upon the beach, the upper beds will spread over and cover up the lower ones.

This structure may frequently be met with along the margins of formations deposited in regions which at one time underwent gradual submergence.

## HISTORICAL GEOLOGY.

---

### PREHISTORIC ERAS.

---

#### INTRODUCTION.

**1330.** The earth's history is divided into geological eras, ages, periods, and epochs, and nature has recorded these in separate rock systems, rock series, rock groups, and rock formations. In geological history the eras and periods shade insensibly into each other; nevertheless, there have been times of revolutionary change. The divisions of time, especially ages, are characterized by the introduction and culmination of successive dominant classes of organisms, the highest expressions of earth life. Thus, we have an age of mollusks, an age of fishes, an age of reptiles, in which these were in their turn the dominant class.

Unconformity of the rock system and change in the life system are the two modes we have of determining and limiting eras, ages, periods, etc. Unconformity indicates blanks in the known record furnished by the rock system, rock series, and rock formations, but the most important changes in the life system of the eras, ages, periods, etc., ought to, and usually do, correspond with the unconformity of the rock system. When there is discordance, as there sometimes is, we should rather follow the life system than the rock system.

**1331.** There are five eras with corresponding rock systems in the earth's history, viz.: (1) Archean, or Eozoic (dawn of animal life), embodied in the Laurentian system; (2) Paleozoic (old life), embodied in the Paleozoic, or Primary system; (3) Mesozoic (middle life), recorded in the Secondary system; (4) Cenozoic (recent life), recorded in the Tertiary and Quaternary systems, and (5) Psychozoic (or era of mind), recorded in the recent system.

These grand divisions, with the exception of the last, are founded on almost universal unconformity of the rock system, and a very great and apparently sudden change

affecting species, genera, families, and even order in the life system.

**1332.** There are also seven ages in the earth's history founded, excepting the first, on the culmination of certain great classes of organisms: (1) The Archean, or Eozoic age, represented by the Laurentian system of rocks; (2) the Age of Mollusks, or Age of Invertebrates, represented by the Silurian system of rocks; (3) the Age of Fishes, represented by the Devonian rocks; (4) the Age of Acrogens, or sometimes called the Age of Amphibians, represented by the Carboniferous rocks; (5) the Age of Reptiles, represented by the Secondary rocks; (6) the Age of Mammals, by the Tertiary and Quaternary, and (7) the Age of Man, by the recent rocks.

---

#### ARCHEAN ERA.

**1333. Laurentian System of Rocks.**—The study of the Canadian rocks, by Sir William Logan, revealed that the highly metamorphic rock which was apparently destitute of fossils and had been known to exist below the lowest Paleozoic rocks was everywhere unconformable with the overlying Cambrian. This established the fact of its being a distinct system of rocks and a distinct era. The only distinct character of the Laurentian rock is the extreme and universal metamorphism of the rock, which consists of altered sandstones, limestones, and clay, as in most other metamorphic rock. Interstratified with the schist, quartzite, and marble are immense beds of iron ore, over 100 feet thick, and great quantities of graphite. This graphite impregnates the rocks, and sometimes is found in pure seams, indicating organic matters which were chiefly vegetable, for graphite is only the extreme term of the metamorphism of coal.

The existence of rhizopods, one of the great limestone builders of subsequent geological epochs, is believed to be demonstrated. This supposed specimen has been called *Eozoon Canadense* (dawn animal).

**PALEOZOIC ERA.**

**1334.** The history of the world from the beginning of the Primary or Paleozoic era is comparatively easy to follow. This era reveals a distinct life system and a distinct rock system, being everywhere unconformed to the Laurentian below, and the Secondary above. The life system of this era is abundant (more than 20,000 species having been described) and distinct. There is a very marked difference in the Primary life system from the life system which precedes and that which follows.

**1335.** The Paleozoic era is divided into three ages, which are embodied in three distinct subordinate rock systems. These ages are characterized by the dominance of a great class of organisms. (1) Silurian system, or Age of Invertebrates, or sometimes called the Age of Mollusks; (2) the Devonian system, or Age of Fishes, and (3) the Carboniferous system, or Age of Acrogens and Amphibians.

In the United States these three systems are generally conformable, but elsewhere they are often unconformable. Of the interval between the Archean and Paleozoic, nothing will be said here, as it is intricate and has scarcely any bearing on the Economic Geology of Coal.

**1336. Silurian System.**—The following table gives the divisions and sub-divisions of the rocks and the corresponding periods of the age in this country:

Silurian	{	Upper Silurian	{	Lower Helderberg Period.
			{	Salina Period.
			{	Niagara Period.
	{	Lower Silurian	{	Trenton Period.
			{	Canadian Period.
	{	Cambrian or Primordial	{	Potsdam Period.
			{	Acadian Period.

It may be said that the Cambrian contains the earliest

known fauna. It is true the lowest rhizopods probably existed in Archean times, but these can not be said to constitute a fauna. It must be remembered that between the Archean and Paleozoic there is a lost interval of enormous duration. Evidently, therefore, the Cambrian fauna is not the actual first fauna. In the United States and Canada about 400 species are known in the Cambrian, of which nearly 100 are trilobites, and in the lowest zone of the Cambrian, viz., olenellus beds, there are 134 species, of which 55 are trilobites. About a dozen plants are also known.

In most of the periods of the Silurian, there was evidently great abundance and variety of life. The number of individuals and species was probably not less than at the present time. Over 10,000 species have been described from the Silurian alone, and they must be regarded as a small part of the actual fauna of that age. The trilobite of the genus *Paradoxides*, shown in Fig. 374, as Nos. 9 and 10, exists in the Acadian epoch, none of which is known afterwards.

Le Conte says: "In certain favored localities, the number of species found in a given area of a single stratum (Silurian Age) will compare favorably with the number now existing in an equal area of our sea bottoms. Yet in all this teeming life, there is not a single species similar to any found in any other geological time."

**1337. Plants.**—*Marine algæ*, or seaweed, called fucoids (*Fucus*, tangle or kelp), or fucus-like plants are the only forms observed. Some of the fossils, formerly regarded as indications of plants, are now believed to be worm tracks, or borings.

**1338. Animals.**—The species observed are all invertebrates. They pertain to the four sub-kingdoms, Protozoans, Radiates, Mollusks, and Articulates.

The Articulates were represented by worms and crustaceans; the Mollusks by brachiopods, pteropods, gasteropods, and cephalopods; Radiates, by crinoids. No evidence has

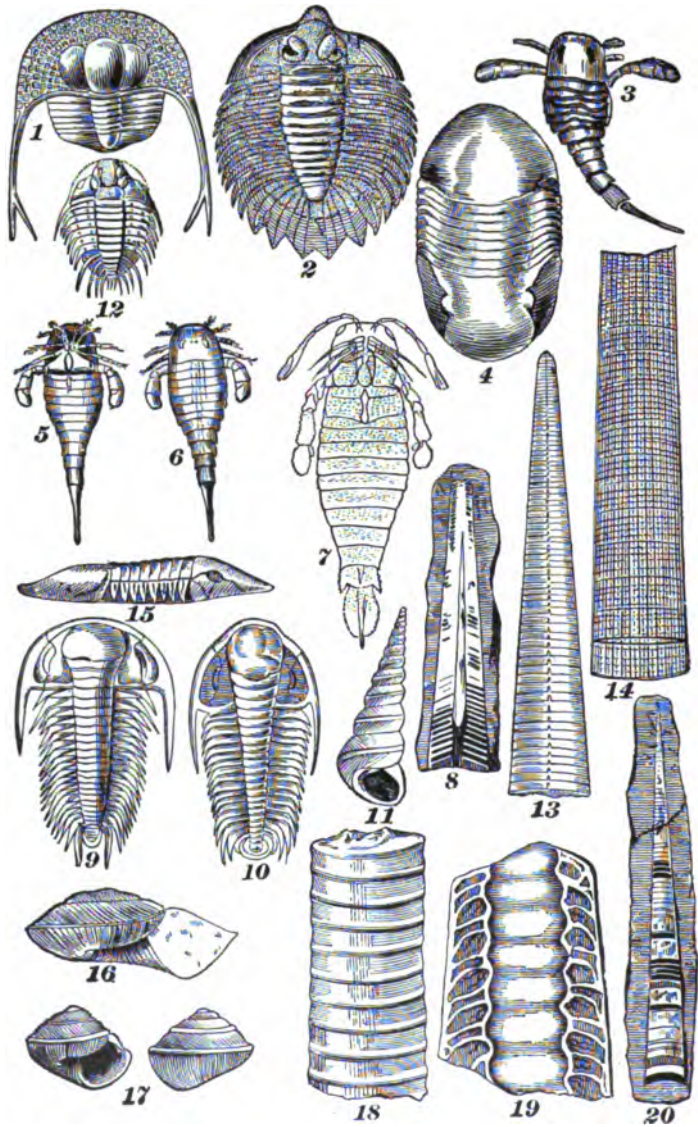

FIG. 374.

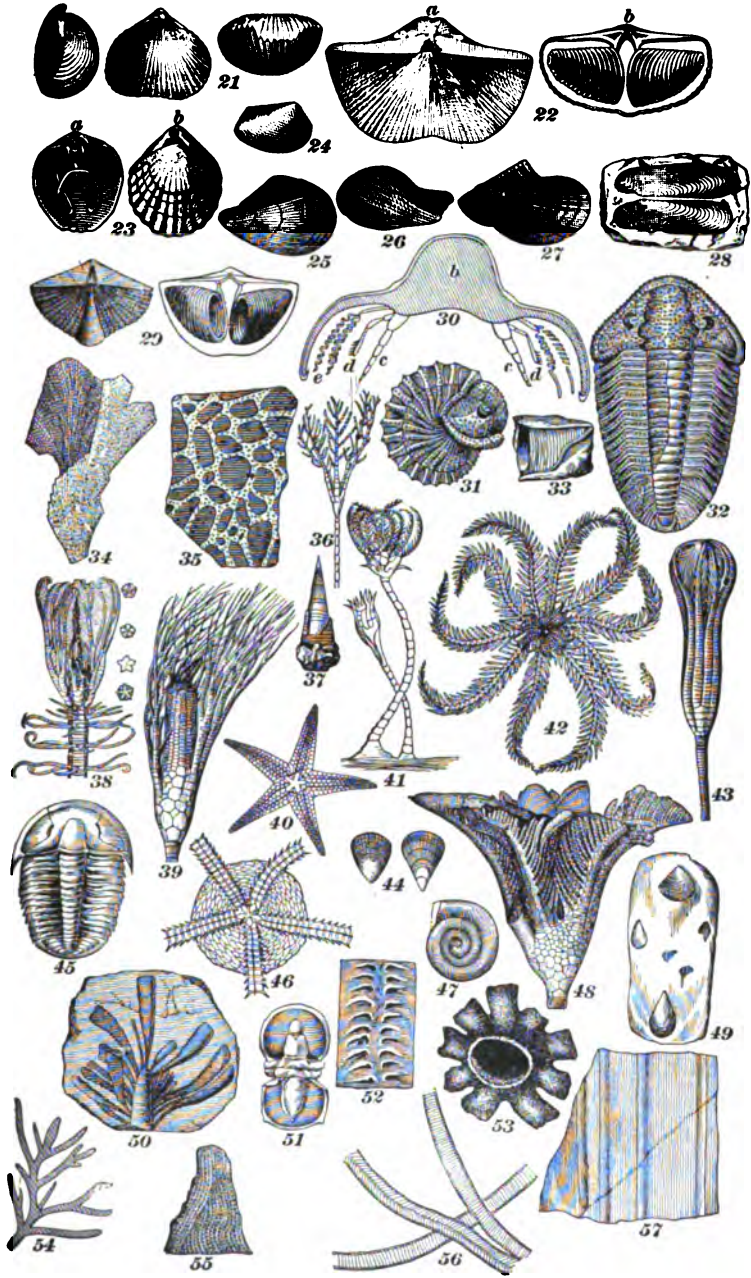

FIG. 374.



yet been found of the existence of polyps among Radiates; or, in the earlier epoch, of lamellibranchs among Mollusks.

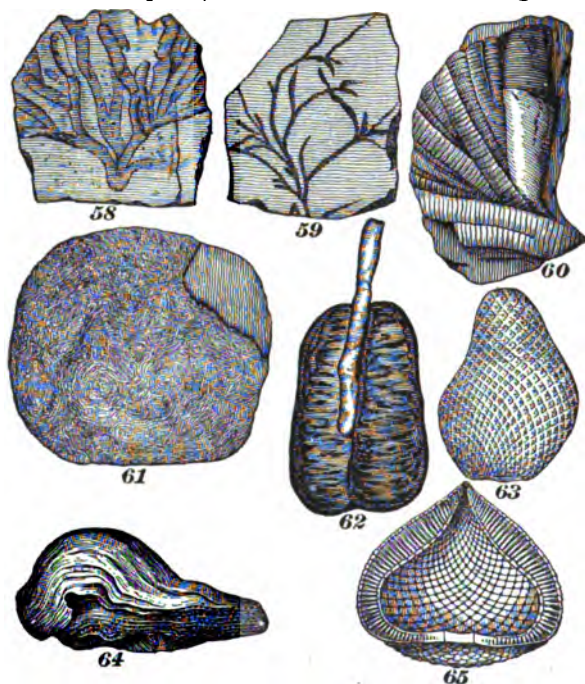

FIG. 374.

Barrande's table showing the number of Silurian species:

Sponges and other Protozoans.....	153
Corals.....	718
Echinoderms.....	588
Worms.....	185
Trilobites.....	1,579
Other Crustaceans.....	348
Bryozoans.....	478
Brachiopods.....	1,567
Lamellibranchs.....	1,086
Heteropods } .....	390
Pteropods } .....	
Gasteropods.....	1,306
Cephalopods.....	1,622
Fishes.....	40

Thin layers of carbonaceous matter are occasionally met in the Silurian, and even, as stated by Murchison, a small bed of anthracite from one to twelve feet thick has been found in the lower Silurian, the material for its formation apparently having been derived from masses of seaweeds.

Coal has been mined in Portugal from the Silurian formations.

We here give some specimens of the principal fossils of the Silurian Age (Fig. 374).

---

#### DEVONIAN SYSTEM, OR AGE OF FISHES.

**1339.** The only plants (Fucoids) found in the Silurian continue, though under different species, in Devonian times. In addition to the fucoids, land plants in considerable number and variety and decided complexity of organization are now introduced. They include ferns, lycopods, and equisetæ, and also conifers; and, by their great size and numbers, probably formed the first true forest vegetation. These plants are similar to those found in the Carboniferous. In the Devonian we find dark bands between the strata, impregnated with carbonaceous matter, and also thin seams of coal, with underclay filled with ramifying rootlets. The coal measures, therefore, are here found imperfectly developed.

Insects made their appearance in the Upper Silurian in the form of cockroaches and scorpions, but in the Devonian for the first time insects are found in great numbers in conjunction with the abundant vegetation.

The characteristic of the Devonian Age, the dominant class, Fishes, is introduced here. This is a new department, which introduces the vertebrates, a great step in the progress of life. The Devonian fishes were all ganoids and placoids. Commencing in the Upper Silurian, few in number, small in size, and of a strange unfishlike form, with the opening of the Devonian Age, fishes greatly increased in size and numbers, until the waters fairly swarmed with them. Never since have fishes apparently been so abundant

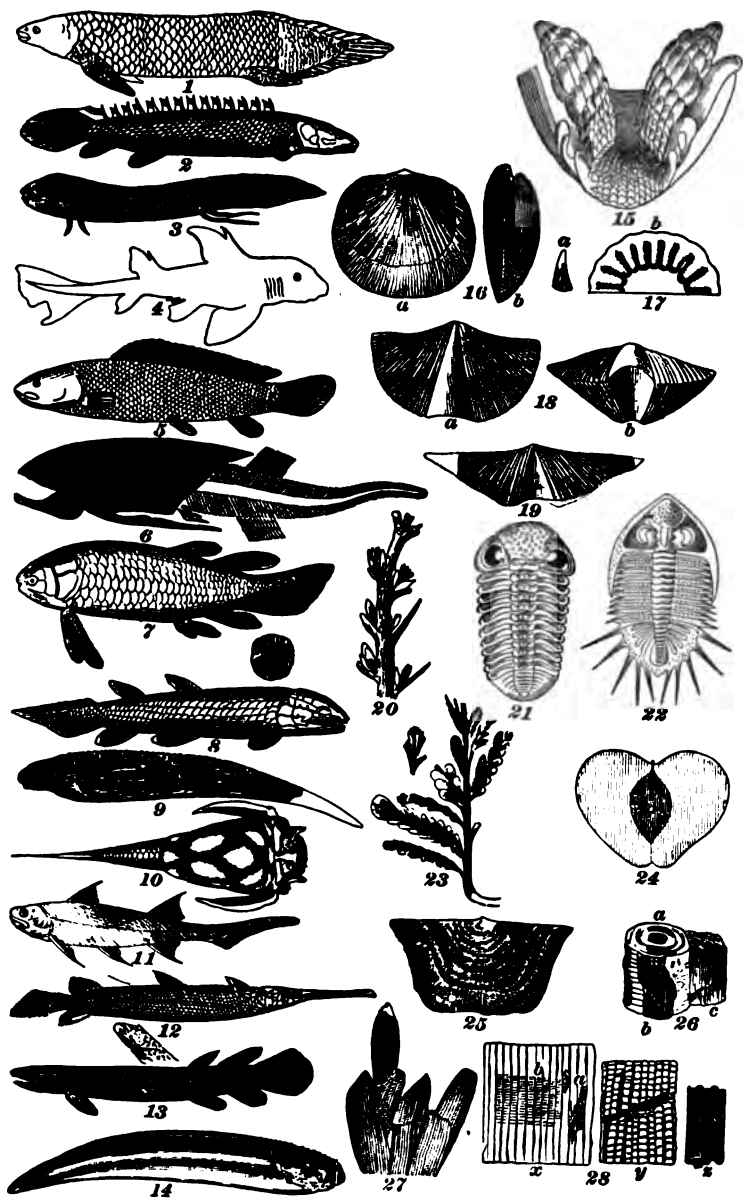

FIG. 875.

or of greater size. And yet all the species, genera, and families of the Devonian Age are now extinct.

In the Devonian are situated some of the coal fields of northwest France, as in Mayenne.

Specimen fossils of the Devonian Age are shown in Fig. 375.

---

**CARBONIFEROUS SYSTEM, OR AGE OF ACROGENS AND AMPHIBIANS.**

**1340.** This is the most important age in the world's history, so far as the human race is concerned. Its coal beds have contributed much to the prosperity and power of this country.

As stated before, the Carboniferous system, or age, is subdivided into three periods:

1. Sub-Carboniferous was the period of preparation.
2. Carboniferous (lower coal measures and upper coal measures) was the period of culmination.
3. Permian was the period of decline and transition to the Mesozoic Age.

The Sub-Carboniferous may be said to be the preparatory marine period upon which the Carboniferous was built. Deposits of coal in this period are sometimes called *false coal measures*.

In Montgomery County, Virginia, there is a seam of coal, 2 to 2½ feet thick, resting on a bed of conglomerate, and 30 to 40 feet higher is another layer, 6 to 9 feet thick, consisting of alternating coal and slate. Lesley says there is a coal bed (and possibly two) in the lower group, at Tipton, Pennsylvania, at the head of the Juniata, 600 feet below the upper shales.

The edge coals, in Scotland, an exceedingly valuable deposit occurring in the mountain limestone below the millstone grit, belong to this period.

The land vegetation of the Sub-Carboniferous period was very similar to that of the lower part of the Carboniferous Proper. There were lycopods of the tribes of *Lepidodendron* and *Sigillaria*, and various ferns, conifers, and calamites. Although the circumstances were less favorable for the

growth of vegetation and accumulation in marshes, the essential prerequisite for the formation of large beds of coal, the vegetation may have been just as profuse for the amount of land.

The animal life was remarkable for the great profusion and diversity of crinoids, pentremites, echinoderms, and lithostrotion.

**1341. The Carboniferous Proper.**—Like other formations, the Carboniferous Proper consists of thick strata of sandstone, shales, and limestones, having interbedded thin seams and beds of iron ore. In the Appalachian coal fields mechanical sediments, shales, and sandstones are thickest, while in the Western coal fields organic sediment, or limestones, predominates.

Le Conte says: "In the Carboniferous Proper period are still enclosed nine-tenths of all the worked coals, and probably nine-tenths of all the workable coals in the world."

In the richest coal fields there are 50 feet of rock for every foot of coal.

In comparing one coal field with another, or in the same coal field, in comparing one portion of the coal series with another, a regular order of succession has not been discovered, excepting that immediately below the seam and in contact with it is a fine fireclay which is a constant attendant, called *underclay*.

Frequently, just above the coal and forming the roof is a slate impregnated with a carbonaceous matter, which is not so constant as the underclay, and is sometimes replaced by sandstone or limestone. This was caused by a progressive subsidence until the seam had been buried under sand and mud forming the sandstone, or after the subsidence and clearing of the water, marine forms of life, zoophytes, encrinites, and mollusks made their way into the area for a period long enough to form a bed of limestone as roofing to the coal.

**1342.** As was said before, there is no fixed superposition of the rocks forming the coal measures. The following is an example from Western Pennsylvania, as published by

Lesley; the beds are numbered in accordance with their succession, beginning below, the lowest being given first:

	Feet.
A. Millstone grit (sometimes called Farewell rock)	?
1. Coal No. A, with 4 ft. of shale.....	6
2. Shell and mud rock.....	40
3. Coal No. B (of mammoth bed of central Pa.)...	3-5
4. Shale, with some sandstone and iron ore.....	20-40
5. Fossiliferous limestone.....	10-20
6. Buhrstone and iron-stone.....	1-10
7. Shale.....	25
8. Coal No. C, the Kittanning cannel.....	3½
9. Shale—soft containing two beds of coal 1'-1¼'.	75-100
10. Sandstone.....	70
11. Coal No. D, Lower Freeport.....	2-4
12. Slaty sandstone and shale.....	50
13. Limestone.....	6-8
14. Coal No. E, Upper Freeport.....	6
15. Shale.....	50
16. Mahoning sandstone.....	75
17. Coal No. F.....	1
18. Shale, thickness considerable.....	?
19. Shaly sandstone.....	30
20. Red and blue calcareous marlytes.....	20?
21. Coal No. G.....	1
22. Limestone, fossiliferous.....	2
23. Slate and shales.....	100
24. Gray clayey sandstone.....	70
25. Red marlyte.....	10
26. Shale and slaty sandstone.....	10
27. Limestone, non-fossiliferous.....	3
28. Shales.....	32
29. Limestone.....	2
30. Red and yellow shale.....	12
31. Limestone.....	4
32. Shale and sand.....	30
33. Limestone, with bands of spathic iron ore.....	25
34. Coal No. H, Pittsburg.....	8.9

The coal measures from the bottom (No. 1) to No. 15 in this section are *sometimes* designated the *lower coal measures*. Of the rest, or upper division, Nos. 16 to 33 are called *barren measures*.

**1343.** In different regions the rocks of any age are distinguished from those of other ages, not by their color or kind, nor by their succession, but by the species of fossil plants and animals they contain. In different parts of the same coal field at the same geological horizon, we are apt to find the same order, because it would be the natural result of the continuity of the strata over the whole basin.

In most cases, coal fields are basin shaped, i. e., they thin out on all sides as they approach their limit and are surrounded by older rocks, somewhat like a picture set in a frame. This is due in all probability, in many instances, to the original form of the area in which they were deposited. Or, the basin, in some cases, perhaps most cases, is due to disturbance of position that has taken place since the rocks were deposited. The strata, by movement of the earth's crust, have been thrown into folds, sometimes wide and gentle, sometimes very abrupt, and when the crests of these folds have been removed by subsequent denudation, areas once continuous have been left as isolated, basin-shaped remnants.

**1344. Source of Coal.**—Eminent geologists advance two theories for the source of coal, viz.: (1) the coal was formed on the spot where the forest grew; (2) the coal was the result of accumulated drift. All agree, however, that it is the result of the decomposition of vegetable matter. The theory most generally accepted is the former, or a combination of both, although it is perfectly clear that, in a few instances, areas of coal have been formed by organic matter drifted into lakes.

**1345. Mode of Growth.**—Le Conte, speaking of *peat*, the first state of coal, says: "Plants take the greater portion of their food from the air, and give it, by the annual fall of leaf and finally by their own death, to the soil. Thus is

formed the humus or vegetable mold found in all forests. This substance would increase without limit were it not that its decay goes on simultaneously with its formation. But in peat bogs and swamps, the excess of water and, still more, the antiseptic property of the peat itself prevent complete decay. Thus, each generation takes from the air and adds to the soil continually and without limit. The soil which is made up entirely of this ancestral accumulation continues to rise higher and higher, until the bog often becomes higher than the surrounding country, and, when swollen by unusual rains, bursts, and floods the country with black mud. A bog is, therefore, composed of the vegetable matter of thousands of generations of plants. It represents so much matter drawn from the atmosphere and added to the soil. In such cases, besides the material deposited from the growth of vegetation, the accumulation may be partly also the result of organic matter drifted from the surrounding surface soil."

Peat is disintegrated and partially decomposed matter composed of carbon, with small and variable quantities of hydrogen, oxygen, and nitrogen.

Dana says: "There is no reason to suppose that the vegetation was confined to the lower lands; it probably spread over the whole continent (American Continent) to its most northern limits. It formed coal only where there were marshes, and where the deposits of vegetable débris afterwards became covered by deposits of sand, clay, or other rock material."

**1346.** The theory that coal has been accumulated by growth of vegetation *in situ*, as in peat swamps of the present date, is supported by the purity of the coal in some of the coal fields of America, the ash not being greater than would result from the plants of which it is composed. In extensive peat swamps, absolutely pure vegetable accumulations, unmixed with sediment, occur; but in buried rafts of drifted vegetable matter of any kind, there must be a large admixture of mud. The theory is further supported by the most complex and delicate parts of the plants, in their natural relation to each other, being preserved.



Again, we find these perfect specimens only in the upper part of the seam, as would be the case with the last fallen leaves. In drifted matter, they would be promiscuously mixed throughout the seam. The presence of stumps, with their spreading roots penetrating the under clay exactly as they grew, is a very important argument in behalf of the *in situ* theory. The underclay of every one of the 100 seams of coal in South Wales is crowded with roots and sometimes stumps. Of the 76 seams in Nova Scotia, 20 have stumps standing in their original positions, with spreading roots penetrating the clay. The other seams have each its under clay filled with *stigmaria* roots.

**1347. Alternation of Peat with Sediment.**—It is necessary to go a step further to account for the clays, sands, and limestones often interstratified with a bed of coal. To account for sand, etc., interstratified with the coal beds, it must be assumed that peat was deposited at the mouths of rivers, and that the foreign strata in coal are due to the sediment brought down by the rivers and laid over the successive layers of peat that formed the coal beds.

A section of the delta deposits of many great rivers reveals alternate layers of fresh water and marine sediment, with thin layers of peat, which accounts for seams of coal being practically one seam at certain points, with the smallest conceivable parting of sediment, which gradually separate until this small parting may have thickened to many feet.

Coals seams, especially thick ones, are very apt to "split," i. e., become horizontally divided into two or more separate beds, by the intervention of layers of ordinary strata of coal measures, such as clay, shales, sandstones, etc.

At *A* (Fig. 376), we have a thick coal seam with little or no parting in the middle, while at *B*, 1,500 feet away from *A*, no less than 30 feet of strata come in between the upper and the lower benches of the same seam. These 30 feet of rock got there in this way: After the bottom bench had formed, it subsided towards *B*, and went on going down, as one by one each layer of sediment, 1, 2, 3, and 4, was de-

posited on top, and as far as it could reach (for depth of water and other conditions prevailing at the time) towards *A*. Then came the formation or accumulation of the upper



FIG. 376.

bench of coal right over the top of both coal at *A* and strata at *B*, and of course beyond, until conditions changed again.

In Staffordshire, England, the "Ten Yard" coal has been proved to split up in a N E direction into no less than ten separate seams of coal in 500 feet of strata, and this in a distance of only five miles.

Fig. 377 is a section of a 30-foot coal seam *C C* which is replaced by 60 feet of rocks and slates at *A B*. The lower

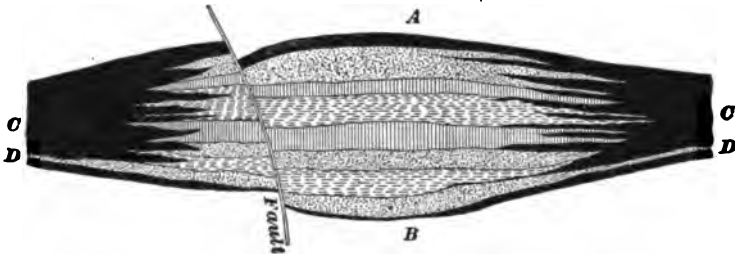

FIG. 377.

seam *D D* is also cut out and replaced at *B* by the same *horse*.

This horse measured 1,200 feet by 804 feet by 60 feet thick in the middle, tailing or thinning out on all sides to nothing.

**1348. The Gradual Change from Wood to Anthracite.**—To illustrate the gradual change in composition in passing from wood to peat, to lignite, to bituminous, and to anthracite, Dr. Percy gives the following table.

In this table Dr. Percy gives the proportions of hydrogen, oxygen, etc., to each 100 parts of carbon:

*F. II.—4*

TABLE 28.

	Carbon.	Hydrogen.	Oxygen.	Disposable Hydrogen.*
Wood (mean of several analyses).....	100	12.18	83.07	1.80
Peat.....	100	9.85	55.67	2.89
Lignite.....	100	8.37	42.42	3.07
Ten yard seam of S. Staffordshire (Bituminous).....	100	6.12	21.23	3.47
Steam coal.....	100	5.91	18.32	3.62
Anthracite.....	100	2.84	1.74	2.63

**AMERICAN COAL FIELDS OF THE CARBONIFEROUS AGE.**

**1349.** 1. Eastern border region, or Rhode Island coal field, a small area in Rhode Island extending northwest into Massachusetts. Area, 500 sq. miles.

2. Michigan, or Interior coal field, an isolated area wholly contained within the lower peninsula of Michigan. Area, 6,700 sq. miles.

3. Central coal field, Illinois, Indiana, and Western Kentucky, sometimes called the Eastern Interior coal field. Area, 47,000 sq. miles.

4. Appalachian or Alleghany Area.—This is the most important coal field in the world. It commences in North-eastern Pennsylvania, and covers the whole coal area of Pennsylvania and Eastern Ohio, and a large portion of Virginia, West Virginia, and Eastern Kentucky, and passes southward through East Tennessee, Northwest Georgia, and ends in middle Alabama. Area, 50,000 sq. miles.

5. Western coal field, or Western Interior Area.—This coal field covers a large portion of Missouri and extends north into Iowa and south, with interruptions, through Arkansas and Indian Territory into Texas, and west into

\* Disposable hydrogen is that portion of hydrogen available for heating purposes in fuel, which is in excess of the quantity required to form water with the oxygen contained in the coal.

**Kansas and Nebraska.** The Illinois and Missouri areas are connected only through the Sub-Carboniferous rocks of the Carboniferous Age. But it is probable that formerly the coal fields stretched across the channel of the Mississippi, and that the present separation is due to erosion along the valley. Area, 98,000 sq. miles.

6. **Acadian coal field, or the Nova Scotia and New Brunswick Area.**—This is a large area on both sides of the Bay of Fundy. Estimated area, 18,000 sq. miles.

Besides these in the Carboniferous Age, there are the following barren, or nearly barren, areas:

1. The Rocky Mountain and Pacific Border region, embracing the Great Basin and Summit Area, containing parts of Montana, Wyoming, Colorado, Utah, and Nevada. Also, the California area in Northern California.

2. The Arctic Region, on Melville Island and other islands between Grinnell Land and Banks Land, on Spitzbergen and on Bear Island, north of Siberia.

Other American coal fields will be described when treating of the Cretaceous and other formations.

**1350. Plication.**—Coal seams and the strata containing them were originally horizontal and continuous; but they are now found sometimes horizontal and sometimes dipping at all angles, and folded in a most complex manner. In the Appalachian region, especially in the anthracite districts of Northeastern Pennsylvania, the strata are much disturbed and the coal seams interstratified with them are

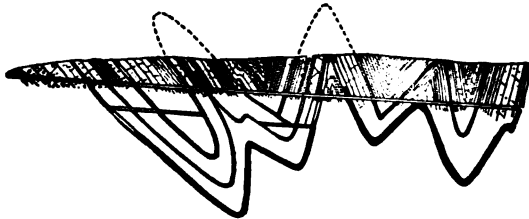

FIG. 378.

often nearly perpendicular, as shown in Fig. 378, which is a section of a coal basin at Panther Creek, Pa.

The coal is anthracite where the rocks are most disturbed, and going westward into regions of less disturbance, the proportions of bitumen, or volatile substances, increase quite regularly. It appears as if debituminization of the coal had taken place from some cause connected with the uplifting.

This will be seen in passing from the anthracite to semi-anthracite and to bituminous in Pennsylvania. The anthracite coal beds of Eastern Pennsylvania correspond in all respects, except that of hardness, to the bituminous beds of Western Pennsylvania, and, no doubt, originally united with them in continuous sheets over the length and breadth of the State. The debituminization of the Rhode Island coal shows a more marked effect. The coals were not only altered by the uplifting to an excessively hard anthracite, but to a graphitic coal.

**1351. Varieties of Coal.**—The varieties of coal depend upon the degree of bituminization, upon the proportion of fixed volatile matter, and upon the purity.

Le Conte says: "Coal consists partly of organic or combustible matter, and partly of inorganic or incombustible matter. On burning coal the organic combustible matter is consumed and passes away in the form of gas, while the inorganic incombustible is left as ash. Now, the relative proportions of these may vary to any extent. We may have a coal of only 2% ash. We may have a coal of 5, 10, 15, or 20% ash; the coal is now becoming poor. We may have a coal of 30 or 40% ash; this is called **bony** or **shaly coal**; it is the valueless refuse of the mines. We may have a coal of 50 or 60% ash; but now it loses the name of coal as well as the ready combustibility of coal, and is called **coaly shale**. Finally, we have the coal of 70%, 80%, 90%, or 95% ash; and thus, it passes, by insensible degrees, through black shale into perfect shale. This passage is often observed in the roof of a coal mine." This shows the varieties depending on purity.

Brown coal and lignite are examples of imperfect coal, showing varieties depending on the degree of bituminization.

The varieties depending on the proportion of volatile matter are not so simple of definition. However, there can be little doubt that these varieties are produced by slight differences in the nature and degree of chemical change in the process of bituminization.

**1352. Metamorphic Coal.**—The normal coal produced by metamorphism is probably not bituminous, while anthracite and graphite are the extreme forms resulting from an after change produced by heat; this heat which changes the coal has distilled away the volatile matter.

Another view is that bitumen is not necessarily correlative with anthracite. It is probable that the heat of metamorphism is not sufficient to produce destructive distillation. Such a degree of heat would hasten the process first described. The folded edges of the seam would still further hasten the process and bring about anthracitism by facilitating the escape of the products of decomposition. In all coal mines  $\text{CO}_2$ ,  $\text{CH}_4$ , and  $\text{H}_2\text{O}$  are being eliminated now; only continue this process long enough, and anthracite and finally graphite will follow. It is a safe conclusion, then, that very high heat is not essential to produce anthracitism.

**1353. Coal Flora.**—The coal flora is one of the most abundant and perfect of the extinct floras. There are 8,660 known fossil species of plants, and of these 2,000 belong in the coal measures.

The coal plants are found principally in the form of stumps and roots in their original position in the underclay; in the form of leaves and branches and flattened trunks, on the upper surface of the coal seam, and in the overlying shale; in the form of logs, apparently drift timber, in the sandstones about the coal seams.

The fern is the most abundant, but the following are in great numbers as well: conifers, lepidodendrids, sigillarids, and calamites.

**1354.** A large number of these specimen fossils are shown in Figs. 379, 380, and 381. Their names are as follows:

1, *welwitschia*; 2, a conifer leaf of half natural size of living congener; 3, *alethopteris lonchitica*; 4, *neuropteris flexuosa*; 5, *callipteris sullivanti*; 6, *pecopteris strongii*, showing fructification, (a) a leaflet; 7, *alethopteris massilensis*; 8, *odontopteris wortheni*; 9, *alethopteris* (7) enlarged;



FIG. 379.

10, *phyllocladus*, a branch; 11, *salisburia*, a branch; 12, section of fruit of *salisburia*; 13, 14, 15, 19, 20, 22, 25, and 26, *cardiocarpon*; 23 and 24, *rhabdocarpon*; 18, 27, and 29, *trigonocarpon*; 16, *neuropteris flexuosa*; 17, *hymen-*

ophyllites alatus; 21, pectopteris strongii; 28, neuropteris hirsuta; 30, 31, and 32, spirifer plenus; 33, productus mesialis; 34, phillipsia lodiensis; 35, chonetes dalmaniana; 36, productus punctatus; 37, ptyonius; 38, euproops danæ;

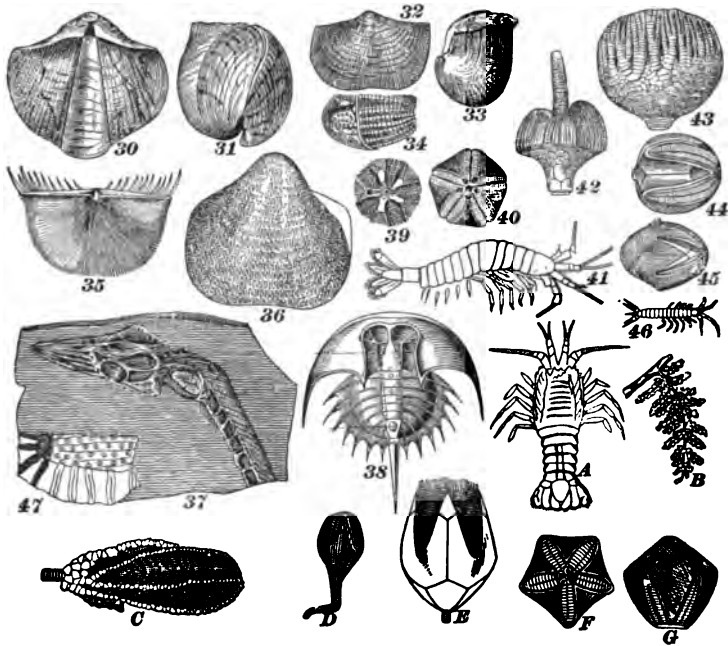

FIG. 380.

39 and 45, pentremites gracilis; 40 and 44, pentremites burlingtoniensis; 42, batocrinus chrystii; 41, paleocarus typus; 46, acanthotelson stimpsoni; 47, stigmaria ficoides; A, anthrapalemon gracilis; B, sphenopteris; C, scaphiocrinus scalaris; D, pentremites pyriformis; E, pentremite restored; F and G, pentremites cervinus; H, lepidostrobus; I and J, sigillaria restored; K, lepidodendron modulatum; L, lepidodendron diplotegioides; M, sigillaria greseri; N, lepidodendron rigens; O, sigillaria levigata; P, sigillaria reticulata; Q, lepidophloios acadianus, fruit; R, calamite, restored; S, lepidodendron corrugatum, branch and fruit; T, sigillaria



obovata; *U*, asterophyllites foliosus; *V*, lepidodendron cor-rugatum, branch and leaves; *W*, lepidodendron politum;

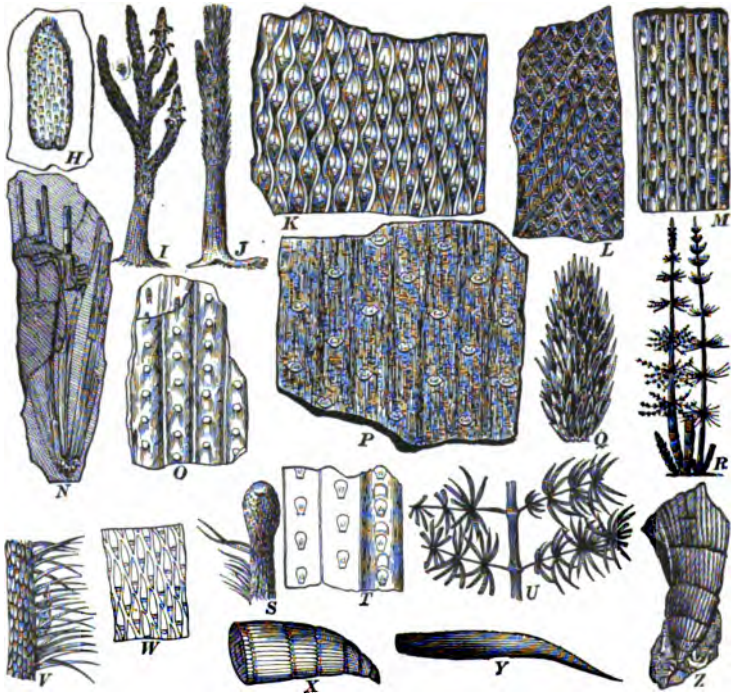

FIG. 881.

*X*, calamites, lower end of stem; *Y*, leaf of sigillaria elegans; *Z*, calamites canneformis, lower end of stem.

NOTE.—Stigmata, so called on account of the round spots (*stigma*) on the surface, are now known to belong to sigillarids and lepidodendrids, and are either roots or spreading rhizomes (underground branches).

#### PERMIAN PERIOD, OR TRANSITION PERIOD.

**1355.** The Mesozoic rocks, excepting in the Rocky Mountain region, are universally unconformable on the Carboniferous, and with this unconformity there is a great change in the fauna. *In all cases* of unconformity of the entire geological formations, there is a lost interval, but in some cases greater than in others. In the interval here

(the Permian), many leaves of record have been recovered, while in the other *intervals*, not a leaf of record has been discovered.

Until recently nothing of interest in the American Permian has been found, except a few shells, but Europe furnishes a larger number of fossils. Permo-Carboniferous coal in North America, Bohemia, and in France.

In Fig. 382 are shown specimens of the Permian fossils. They are:

*A* and *B*, *walchia piniformis* (Permian of Europe); *C*, *eumicrotis hawni*; *D*, *gasteropod*; *E*, *bakewellia parva*; *F*, *pleurophorus subcuneatus*; *G*, *myalina permianar*; *H*, *pseudomonotis*; *I*, *platysomus gibbosus*; *J*, restoration of *paleoniscus*.

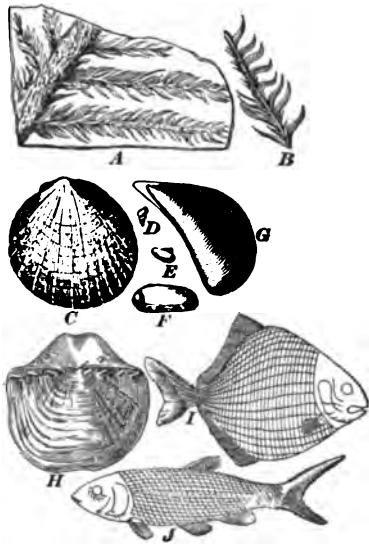

FIG. 382.

#### MESOZOIC ERA, OR AGE OF REPTILES.

**1356.** This era is divided into three periods:

1. Triassic, because of its three-fold development where first studied in Germany.
2. Jurassic, because of the development of its strata in the Jura mountains.
3. Cretaceous, because the chalks of England and France belong to this period.

In Europe the Triassic formation is more distinctly separated from the Jurassic than in America, and they are, therefore, spoken of in this country as the Jura-Trias, or Triasso-Jurassic.

**1357. Triassic.**—See Jura-Trias.

**1358. Jurassic.**—In the Jurassic are reproduced on a large scale the conditions favorable to luxuriant growth of

plants and for their accumulation and preservation in the form of coal. To this period belong the coal fields of Kimmeridge (the Kim coal) in England; the Moorland coal of Yorkshire, England, and the coal of Brora, Sutherlandshire, Scotland.

**1359. Jura-Trias, or Triasso-Jurassic.**—To the Jurassic, or Triassic, belong the coals of North Carolina, or Dan river, Eastern Virginia, or Richmond and Piedmont, and some of the coal fields of China, India, and Australia. These coal measures have a general structure similar to those of the Carboniferous, consisting of alternate beds of sand and clay, and occasional limestones containing the seams of coal, and also beds of clay iron-stone. Underclay with stumps and roots, and leaf impressions, innumerable, are found in the roof shales. It is, therefore, logical to conclude that the manner of accumulation was the same as with those in the Carboniferous Age.

**1360.** Specimen fossils of the Triassic age are shown in Fig. 383. They are:

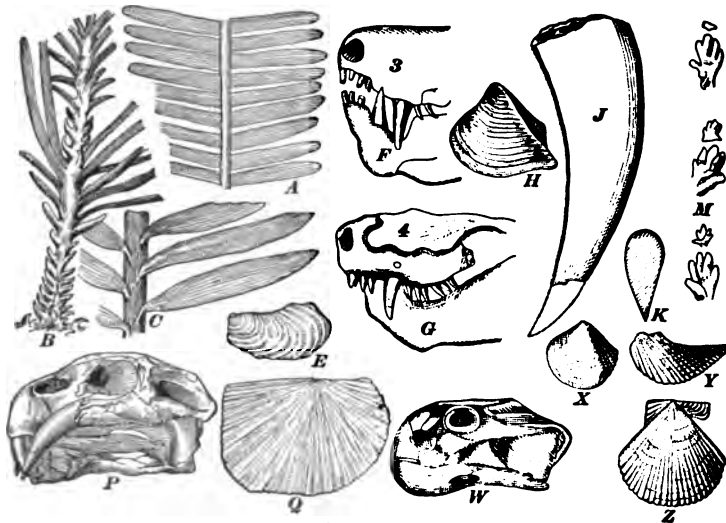

FIG. 383.

*A*, pterophyllum jegeri, a cycad; *B*, voltzia heterophylla,

a conifer; *C*, podozamites emmonsi, a cycad; *E*, avicula socialis; *F*, and *G*, lycosaurus; *H*, myophoria lineata; *J*, *K*, bathygnathus borealis; *M*, tracks of a cheirotherium, a labyrinthodont; *P*, dicynodon lacerticeps; *Q*, daonella lom-melli; *W*, oudenodon bainii; *X*, cardium rheticum; *Y*, avicula contorta; *Z*, pecten valoniensis.

**1361.** Specimen fossils of the Jurassic age are shown in Fig. 384. Their names are:

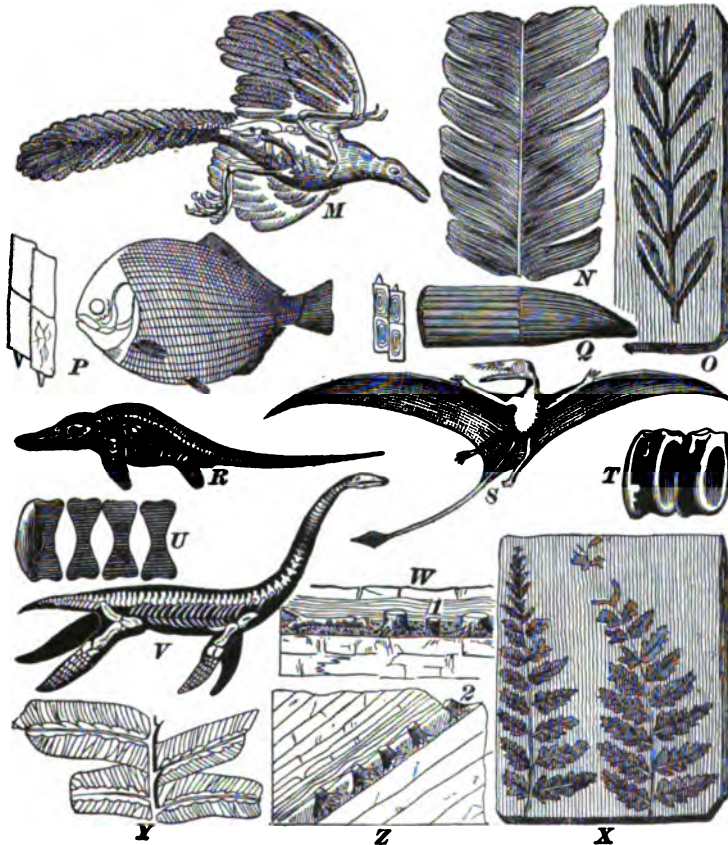

FIG. 384.

*M*, archeopteryx macrura; *N*, pterophyllum comptum,

a cycad; *O*, *pachypteris lanceolata*; *P*, *ganoid*, tetragonolepis, restored, and scales of the same; *Q*, tooth of ichthyosaurus; *R*, *ichthyosaurus communis*; *S*, *rhamphorhynchus phollurus*; *T*, *U*, vertebræ of ichthyosaurus; *V*, *plesiosaurus dolichodeirus*; *W*, *Z*, 1 and 2, show fossil soils of forest grounds with erect stumps and ramifying roots *in situ*; *X*, *coniopteris murrayana*; *Y*, *hemitelites brownii*, a fern.

**1362.** Specimen fossils of the Jura-Triassic age are shown in Fig. 385. They are as follows:

*A*, *walchia diffusus*; *B*, *pecopteris falcatus*; *C*, *alethopteris whitneyi*; *D*, *otozamites macombii*; *E*, *zamites occidentalis*; *F*, branch of conifer (brachyphyllum); *G*, *neuropteris*; *H*, branch of conifer; *I*, *neuropteris linefolia*; *J*, *podozamites emmonsii*; *K*, *podozamites crassifolia*; *M*, fruit of conifer; *N*, *teniopteris elegans*.

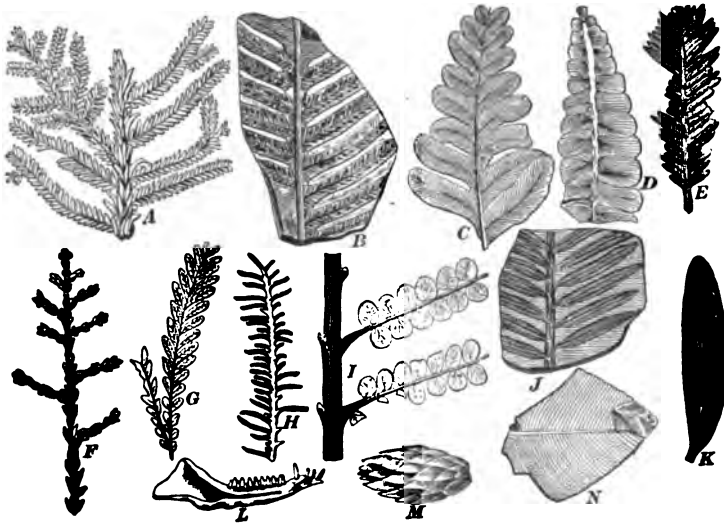

FIG. 385.

**1363. Cretaceous.**—The chalk (a soft, white, pure carbonate of lime) of England and France belongs to the Cretaceous period. The chalk has scattered through it in layers, or irregularly, nodules of pure flint. With this exception, the Cretaceous period consists of sands, clays, and limestone in much the same condition as in the other

formations, but, as a whole, they are less frequently metamorphic than the older rocks.

By referring to the Geological Chart for North America, it will be seen that the Cretaceous is divided into Upper and Lower, but it might conveniently be subdivided into Upper, Middle, and Lower. These subdivisions are local. In Europe, nearly everywhere, the Tertiary is unconformable on the Cretaceous, but in America, there is a transition period between the Cretaceous and Tertiary, called the Laramie; sometimes it is included in the Upper Cretaceous.

**1364. Laramie-Cretaceous.**—This, excepting the Carboniferous Age, contains the largest coal field in the United States and Canada.

1. Plateau Coal Field.—This valuable field covers most of the Laramie plains in Montana and Wyoming, and stretches into Utah. The area must be very great.

2. Coal Field of the Plains.—Of great area in Dakota, and extending into Assiniboia, Saskatchewan, Alberta, and Athabasca in British America. Area, enormous.

3. New Mexico Coal Field.

4. Kansas-Colorado Coal Field.—A large coal field covering the greater portion of Western Kansas and Eastern Colorado.

5. Pacific Coal Field.—This is comprised of the Seattle, Carbon Hill, and Bellingham Bay areas in Washington.

6. British Columbia Coal Field.—The Nanaimo coal areas of Vancouver's Island.

7. Californian Coal Field.—Monte Diablo and Corral Hollow areas in California.

8. The \*Coahuila Coal Field.—Including all the coal areas on the Sabinas River, at Fuente and San Tomas, in the State of Coahuila, Mexico, and Eagle Pass, etc., Texas.

---

\*There is a doubt as to whether the Coahuila coal is Laramie-Cretaceous or Carboniferous.

Many of these coals are in no way inferior to the Carboniferous coals.

The Coahuila and Colorado (Crested Butte and El Moro) are good coking coals.

These fields produce anthracite, bituminous, high-grade lignites, and lignites.

**1365.** In Fig. 386 are shown specimens of Cretaceous fossils. They are: *A*, restoration of *ichthyornis victor* (after Marsh); *B*, hadrosaurus (restored by Hawkins); *C*, *belemnites impressus* (after Gabb); *D*, *salix proteafolia*; *E*,



FIG. 386.

*liquidambar integrifolium*; *F*, *protophyllum quadratum*; *G*, *laurus nebrascensis*; *H*, *sassafras araliopsis*; *I*, *fagus polyclada*.

As there are no coal formations of any value above the Laramie, it is scarcely within the province of Economic Geology of Coal to go into the more recent ages; but the leading fossils found in these recent formations are illustrated, as they are very useful as a guide to the prospector.

**1366.** Specimens of Tertiary fossils are shown in Fig. 387. They are as follows:

*A*, head of a sivatherium giganteum; *B*, tooth of zeuglo-

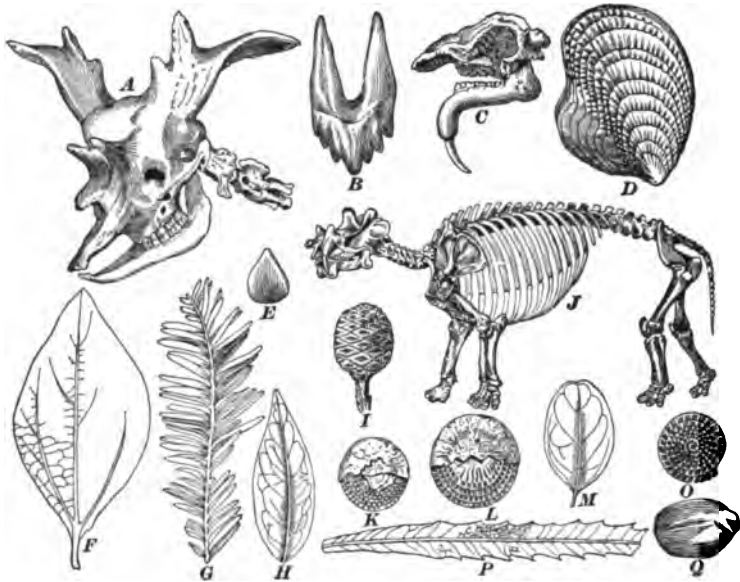

FIG. 387.

don cetoides; *C*, head of dinotherium giganteum; *D*, ostrea selleformis; *E*, fagus ferruginea, nut; *F*, cinnamomum mississippiense; *G*, leaf of sequoia langsdorfii; *H*, andromeda vacciniifoliae affinis; *I*, fruit of sequoia langsdorfii; *J*, tinoceras ingens; *K*, *L*, *O*, nummulina levigata; *M*, quercus crassinervis; *P*, quercus saffordi; *Q*, carpolithes irregularis.

**1367.** Specimens of Quaternary fossils are shown in Fig. 388. They are:

*A*, mammoth (elephas primigenius), skeleton; *B*, tooth of



mastodon americanus; *C*, mastodon americanus; *D*, mega-

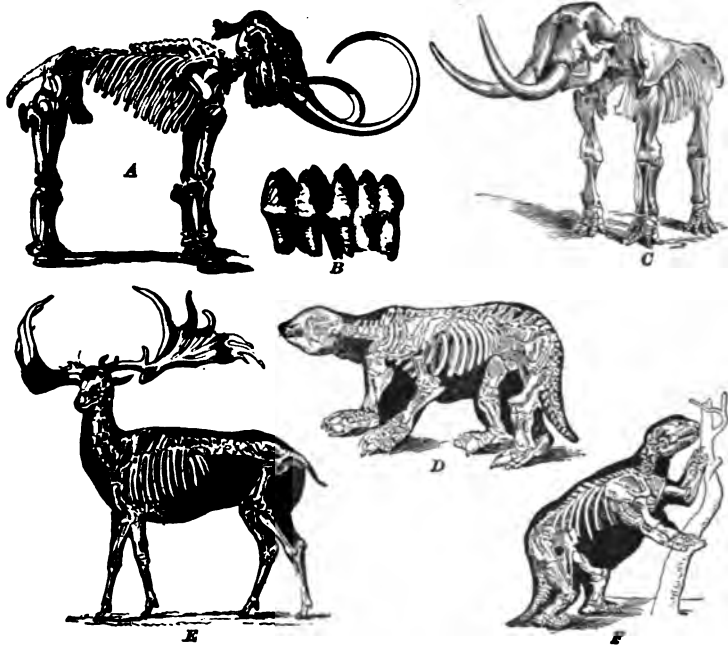

FIG. 388.

therium cuvieri; *E*, Irish elk (*cervus megaceros*); *F*, *mylodon robustus*.

## GENERAL INFORMATION.

### COAL SEAMS.

**1368. Thickness of Coal Seams.**—Coal seams vary in thickness from a *fraction of an inch* to 80 or 100 feet. A seam can scarcely be said to be workable if less than 18 inches. A pure simple seam is seldom more than 8 or 10 feet thick. Mammoth seams in the south of France and in the anthracite region of Pennsylvania are produced by the running together of several smaller seams, by the thinning out of the interstratified shales, etc. In these mammoth seams there is from 20% to 40% of shale and worthless Carboniferous matter.

**1369. Number and Aggregate Thickness.**—The strata, including the coal seams in a single coal field, are

repeated many times. A section of the South Joggins coal field, Nova Scotia, shows eighty-one coal seams, but only a few are workable. In Westphalia, Germany, there are 117 seams. The aggregate thickness of all the seams in

- Lancashire is 150 feet.
- Pottsville, Pa., is 113 feet.
- Western Coal Fields is 75 feet.
- Westphalia is 274 feet.
- Mons, France, is 250 feet.

The great anthracite region of Pennsylvania is largely Lower Carboniferous or lower coal measures. However, in a deep trough in the otherwise nearly horizontal outspread of Catskill formation, the coal measures of Carbondale, Scranton, and Wilkes-Barre have been preserved. They cross Luzerne County so deep in this trough that it has retained not only the *lower* and *middle*, but the upper coal beds, above the Pittsburg bed, and even a remnant of still higher rocks (containing Permian fossils).

The greatest development of the lower coal is in Pennsylvania, and of the upper in the States further west. The highest beds of the series appear to occur west of the Mississippi, in Kansas, where they merge into the Permian.

The following is a section (by J. P. Lesley) of that part above the Pittsburg bed (see Art. 1342) in Waynesburg, Green County, Pa. :

	Feet.
1. Shale, brown, ferruginous.....	30
2. Sandstone, gray and slaty .....	25
3. Shale, yellow and brown.....	20
4. Limestone—the great limestone south of Pittsburg (including two coal beds, 2½ feet and 1 foot) .....	70
5. Shale and sandstone.....	17
6. Limestone.....	1
7. Shale and sandstone.....	40
8. Coal .....	6
9. Shale, brown and yellow.....	10
10. Sandstone, coarse brown.....	35

	Feet.
11. Shale .....	7
12. Coal .....	1½
13. Limestone 4 feet, shale 4, limestone 4, shale 3 .....	15
14. Shale 10 feet, sandstone 20, shale 10.....	40
15. Coal .....	1
16. Sandstone (at Waynesburg) with 4 ft. of shale .....	24

The Eastern Interior Coal Field and the Western Interior Area may be regarded as one, having been separated by denudation, and, like the Appalachian Coal Field, may have been a hollow surrounded by high lands.

**1370. Climate.**—Le Conte says: “The climate of the coal period was undoubtedly characterized by greater warmth, humidity, uniformity, and a more highly carbonated condition of the atmosphere than now. Most of these characteristics, if not all, are indicated by the nature of the vegetation.

“(1) The warmth is shown by the existence of a tropical vegetation. Of the present flora of Great Britain, about one thirty-fifth are ferns, and none of these tree ferns. Of the coal flora of Great Britain, about one-half were ferns, and many of these tree ferns. At present, in all Europe, there are not more than sixty known species of ferns. In European coal measures, there are 350 (Lesquereux) species, and these are certainly but a fraction of the actual number then existing. That this indicates a tropical climate is shown by the fact that out of 1,500 species of living ferns known twenty years ago, 1,200, or four-fifths, were tropical species. The number of known living ferns is about 3,000 (Nature, Aug., 1876), but the proportion of tropical species is still probably the same. Even in the tropics, however, the proportion of ferns is far less than in Great Britain during the coal period.

“Again, tree ferns, arborescent lycopods, cycads, and Araucarian conifers are now wholly confined to tropical or

sub-tropical regions. The prevalence of these tropical families and their immense size, compared with their congeners of the present day, would seem to indicate not only tropical but ultra-tropical conditions. And these conditions prevailed, not only in the United States and Europe, but northward into polar regions, for in Melville Island, 75° north latitude, and Spitzbergen, 77° 33' north latitude, have been found coal strata containing tree ferns, gigantic lycopods, calamites, etc.

“(2) The humidity is indicated by the fact that tree ferns and arborescent lycopods are most abundant now on islands in the midst of the ocean, and, further, by the great extent of the coal swamps, and, perhaps, also by the general succulence of, or the predominance of, cellular tissue in the plants of that period.

“(3) The uniformity is proved by the great resemblance and often identity of the species in the most widely separated regions. According to Lesquereux, out of 434 American and 440 European species, 176 are common, and the remainder far less diverse in character than the species of the two floras at present. Again, in all latitudes from the tropics to 75° north latitude, coal species are extremely similar. Such uniformity of vegetation shows a remarkable uniformity of climate. From the earliest times until the present, there has been probably a gradual evolution of continents—a gradual differentiation of land and water, a consequent differentiation of climates, and a corresponding differentiation of faunas and floras.

“(4) The carbonated condition of the atmosphere is proved by the large quantity of carbon laid up in the form of coal, the whole of which was withdrawn from the atmosphere in the form of carbonic acid. It is also indicated by the nature and the luxuriance of the vegetation. The proportion of carbonic acid in the atmosphere is now about  $\frac{1}{10000}$  per cent. ( $\frac{1}{10000}$ ). Now, since carbonic acid is the necessary food of plants, it is natural to expect that, up to a certain limit, the increase of atmospheric carbonic acid would increase the luxuriance of vegetation.

“ We may, therefore, picture to ourselves the climate of this period as warm, moist, uniform, stagnant (for currents of air are determined by difference of temperature), and stifling from the abundance of carbonic acid. Such physical conditions are extremely favorable to vegetation, but unfavorable to the higher forms of animal life.”

**1371. Plants and Genera.**—In European coal beds, much the same genera of plants are found as in American coal beds, and very many of the species are identical. In this respect, the animal and vegetable kingdoms are in strong contrast, for the species of animals common to the two continents have always been few.

---

### VARIETIES OF COAL.

**1372.** Dana classes the varieties of coal as follows:

1. **Anthracite.** Hardness, 2 to 2.5. Specific gravity, 1.32 to 1.7, Pennsylvania; 1.81, Rhode Island; 1.26 to 1.36, South Wales. Luster bright, often sub-metallic, iron-black, and frequently iridescent. Fracture conchoidal. Volatile matter after drying, 3 to 6 per cent. Burns with a feeble flame of a pale color. The anthracites of Pennsylvania contain ordinarily 85 to 93 per cent. of carbon; those of South Wales, 88 to 95; of France, 80 to 83; of Saxony, 81; of Southern Russia, sometimes 94 per cent. Anthracite graduates into bituminous coal, becoming less hard, and containing more volatile matter; and an intermediate variety is called “free burning anthracite.”

**1373. 2. Bituminous Coals.**—Under the head of bituminous coals a number of kinds are included which differ strikingly in the action of heat, and which, therefore, are of unlike constitution. They have the common characteristic of burning in the fire with a yellow, smoky flame, and giving out on distillation hydro-carbon oils or tar, and, hence, the name bituminous. The ordinary bituminous coals contain from 5 to 15 per cent. (rarely 16 or 17) of oxygen (ash included); while the so-called brown coal, or lignite, contains from 20 to 36 per cent. after the expulsion, at 212° Fahr.,

of 15 to 36 per cent. of water. The amount of hydrogen in each is from 4 to 7 per cent. Both have a usually bright, pitchy, greasy luster (whence often called Pechkohle in Germany), a firm, compact texture, are rather fragile compared with anthracite, and have a specific gravity of 1.14 to 1.40. The brown coals have often a brownish-black color, whence the name, and more oxygen, but in these respects and others they shade into ordinary bituminous coals. The ordinary bituminous coal of Pennsylvania has a specific gravity of 1.26 to 1.37; of Newcastle, England, 1.27; of Scotland, 1.27 to 1.32; of France, 1.2 to 1.33; of Belgium, 1.27 to 1.3. The most prominent kinds are the following:

**1374. 3. Caking Coal.**—A bituminous coal which softens and becomes pasty, or semi-viscid, in the fire. This softening takes place at the temperature of incipient decomposition, and is attended with the escape of bubbles of gas. On increasing the heat, the volatile products, which result from the ultimate decomposition of the softened mass, are driven off, and a coherent, grayish-black, cellular, or fritted mass (coke) is left. Amount of coke left (or part not volatile) varies from 50 to 85 per cent. Byerite is from Middle Park, Colorado.

**1375. 4. Non-Caking Coal.**—Like the preceding in all external characters, and often in ultimate composition; but burning freely without softening or any appearance of incipient fusion.

**1376. 5. Cannel Coal (Parrot Coal).**—A variety of bituminous coal, and often caking; but differing from the preceding in texture and to some extent in composition, as shown by its products on distillation. It is compact, with little or no luster, and without any appearance of a banded structure; and it breaks with a conchoidal fracture and smooth surfaces; color, dull black or grayish-black. On distillation it affords, after drying, 40 to 66 per cent. of volatile matter, and the material volatilized includes a large proportion of burning and lubricating oils, much larger

than the above kinds of bituminous coal; whence it is extensively used for the manufacture of such oils. It graduates into oil-producing coaly shales, the more compact of which it much resembles.

**1377. 6. Torbanite.**—A variety of cannel coal of a dark brown color, yellowish streak, without luster, having a sub-conchoidal fracture; hardness, 2.25; specific gravity, 1.17 to 1.2. Yields over 60 per cent. of volatile matter, and is used for the production of burning and lubricating oils, paraffin, and illuminating gas. It is found at Torbane Hill, near Bathgate, in Linlithgowshire, Scotland. It is also called Boghead cannel.

**1378. 7. Brown Coal (Lignite).**—The prominent characteristics of brown coal have already been mentioned. They are non-caking, but afford a large proportion of volatile matter. They are sometimes pitch-black, but often rather dull and brownish-black. Specific gravity, 1.15 to 1.3; sometimes higher from impurities. It is occasionally somewhat lamellar in structure. Brown coal is often called lignite. But this term is sometimes restricted to masses of coal which still retain the form of the original wood. Jet is a black variety of brown coal, compact in texture, and taking a good polish, whence its use in jewelry.

**1379. Composition.**—Most mineral coal consists mainly, as the best chemists now hold, of oxygenated hydro-carbons. Besides oxygenated hydro-carbons, there may also be present simple hydro-carbons (that is, containing no oxygen).

*Sulphur* is present in nearly all coals. It is supposed to be usually combined with iron, and when the coal affords a red ash on burning, there is reason for believing this true. But Percy mentions a coal from New Zealand which gave a peculiarly white ash, although containing 2 to 3 per cent. of sulphur, a fact showing that it is present, not as a sulphide of iron, but as a constituent of an organic compound. The discovery by Church of a resin containing sulphur (*Tasmanite*), gives reason for inferring that it may exist in this

coal in that state, although its presence as a constituent of other organic compounds is quite possible.

**1380.** The following table refers to the coals found in the United States:

	Fracture of Coal.	Cleat of Coal.
Rhode Island.....	Conchoidal, or shelly.	.....
Anthracite region, Pa.....	Conchoidal, glossy, and lustrous.	Very irregular.
Semi-Anthracite region, Pa.	Irregular and cuboidal.	More regular.
Pittsburg region, Pa.....	Clean, bright, even cuboidal.	Remarkably regular, nearly vertical jointing.
Ohio.....	Fairly regular and smooth.	Makes blocky coal.
Indiana.....	Fairly regular and smooth.	Makes blocky coal.
Illinois.....	Rough to smooth.	Poorly developed.
Iowa.....	Rugged, irregular.	Hardly any.

**VARIETIES OF LIMESTONE.**

**1381.** The following in substance is given by Dana:

**Massive Limestone.**—Compact uncrystalline limestone of dull gray, bluish gray, brownish, and black colors; in texture, varying from earthy to compact semi-crystalline.

It consists essentially of calcite or carbonate of calcium, but is often impure with clay or sand.

When burned, limestone becomes quicklime through loss of carbonic acid; and, at the same time, all carbonaceous materials are burned out, and the color, when it is owing solely to these, becomes white.

Magnesian limestone, dolomite, consists of calcium and magnesium, but not distinguishable in color or texture from ordinary limestone. The amount of magnesian carbonate present varies from a few per cent. to that in true dolomite which can not be distinguished by the eye from granular



limestone. Much of the common limestone of America is magnesian.

In some limestones, the fossils are magnesian, while the rock is common limestone.

**Hydraulic Limestone.**—A limestone containing some clay, and affording a quicklime, the cement of which will *set* under water.

**Oolite, or Roe Stone.**—Limestone, either magnesian or not, consisting of minute concretionary spherules, and looking like the petrified roe of fish; the name is from the Greek, meaning egg.

**Chalk.**—A white, earthy limestone easily leaving a trace on a board; composition, the same as that of ordinary limestone.

**Marl.**—A clay containing a large proportion of lime.

**Shale Marl.**—Marl consisting largely of shells or fragments of shells.

**Shell Limestone, Coral Limestone.**—A rock made of shells or corals.

**Travertine.**—A massive limestone formed by deposition from calcareous springs or streams.

**Stalagmite, Stalactite.**—Depositions from water trickling through the roofs of limestone caverns, form calcareous cones and cylinders pendent from the roofs, which are called stalactites, and incrustations on the floors, which are called stalagmites.

**Granular Limestone (Statuary Marble).**—Limestone having crystalline granular texture, white to gray color, often clouded with other colors from impurities; it is a metamorphic rock; it was originally common limestone. All the fossils present were obliterated, except in some cases of partial metamorphism. The varieties are as follows: Statuary marble, ornamental and architectural marble, verd-antique, or ophiolyte, micaceous, tremolitic, graphitic, chloritic, and chondroditic.

## GLOSSARY.

**1382.** *Acrogens*.—Consist of vascular tissue in part and grow upwards; as (1) ferns; (2) lycopods (ground-pine); (3) equisetæ; and include many genera of trees of the coal period.

*Age*.—(1) Any great period of time in the history of the earth or the material universe, marked by special phases of physical condition or organic development; as, the Age of Mammals. Called also *era*. (2) One of the minor subdivisions of geological time, a subdivision of the epoch and correspondent to the stage or formation; recommended by the International Geological Congress. See Geological Chart for North America.

*Amphibians*.—Animals capable of living both on land and in water, like the frog.

*Antiseptic*.—Opposed to or counteracting decay.

*Araucarian*.—A genus of fossil trees of the pine family (coniferæ) represented by trunks (often of great size), and closely allied to araucaria, a genus of large evergreen trees of the pine family.

*Arborescent*.—(1) Having the nature of a tree; tree-like in appearance or size. (2) Branching like a tree.

*Articulates*.—Consisting (1) of a series of joints or segments; (2) having the legs, when any exist, jointed; (3) having the viscera and nervous cord in the same general cavity; (4) having no *internal* skeleton, as worms, crustaceans, insects.

*Brachiopods*.—See definition of Foraminifera, and also 22 a, 22 b, 23 a, 23 b, and 29, Fig. 374.

*Bryozoans*.—Moss animals, so named with reference to the moss-like corals they often form. The corals consist of minute cells either in branched, reticulated, or encrusting forms. They are often calcareous; and as such were common in the Silurian Age, and still occur.

*Bulirstone* (Burrstone).—A cellular but very compact silicious rock from which the best millstones are made.

*Calamites*.—Fossil plants of the Carboniferous coal formations, having the general form of plants of the modern *equisetæ* [the horse-tail, or scouring rush, family (see definition of *equisetæ*)], but sometimes attaining the height of trees and having the stem more or less woody within (*R*, Fig. 381, is a calamite restored).

*Cephalopods*.—Cuttlefishes. There are two orders of cephalopods; one having external shells and four gills; a second, having sometimes internal shells but no external, and having but two gills. The external shells are distinguished from those of gasteropods (or ordinary univalves) by having, with a rare exception, transverse partitions. They may be either straight or coiled; but with few exceptions they are coiled in a plane instead of being spiral.

*Clay Iron-stone*.—The ore is generally the carbonate of iron, called siderite (or often spathic iron). It contains as impurity ten to thirty per cent., or more, of silica and other earthy matters, and hence is called clay iron-stone.

*Clinometer*.—An instrument employed for determining the dip of strata.

*Coccospheres*.—Supposed shells of minute plants having but one cell.

*Columnar*.—Columnar structure—structure, as in certain igneous rocks, showing a tendency to cleave into columns. Columnar appearance—like the shaft of a column.

*Congener*.—An organism that belongs to the same genus as another, or to one closely related; a member of the same stock, group, kind, or species with another.

*Conifers*.—A plant which has a bark and grows by an addition annually to the exterior of the wood, between the wood and the bark, and hence the wood shows, in a transverse section, rings of growth, each forming a single year. Examples are the pine, spruce, hemlock, etc.

*Correlative*.—Mutually involving or implying one another.

*Crustaceans*.—Animals whose bodies are protected by shells, as crabs, lobsters, shrimps.

*Crystalline*.—Composed of angular grains or particles more or less crystallized in place.

*Culmination*.—The highest point, condition, or degree of achievement; as the culmination of life.

*Cycads*.—A family of palm-like or fern-like plants with unbranched stem bearing a crown of feather-like leaves, rolled inwards from the apex in a coil.

The Cycadaceæ embrace 9 genera and 75 species, chiefly of the Southern Hemisphere.

*Debris*.—An aggregation of detached fragments of rocks, whether *in situ* at the base of its original cliff, or heaped up after transportation (drift in part).

*Delta*.—An alluvial deposit formed at the mouth of a river; so called from its frequent resemblance to the fourth letter delta ( $\Delta$ ) of the Greek alphabet.

*Detritus*.—(1) Loose fragments or particles of rock, whether angular or water-worn, especially the latter. (2) A mass of disintegrated material of any kind; rubbish; waste.

*Dominant*.—Conspicuously prominent in point of numbers.

*Dyke*.—A mass of igneous rock filling a fissure in other rocks into which it has been intruded.

*Echinoderms*.—Animals having their exterior more or less calcareous and often furnished with spines; and having distinct nervous and respiratory system and intestines, as starfish, crinoids, etc.

*Encrinites or Crinidea*.—Having a regular radiate structure, and arms proceeding from the margin of the disk; also, a stem consisting of calcareous disks, by means of which, when alive, they are attached to the sea bottom, or some support, so that they stand in the water and spread their rays like flowers, the mouth being at the center of the flower.

*Epoch*.—The chronological subdivision of geological history of the third order; as the Hamilton *epoch*.

The corresponding stratigraphic division proposed by the

International Congress of Geologists is the *series*; that recognized by the U. S. Geological Survey is the *formation*. Compare with *group*, and see Geological Chart for North America.

*Equisetæ*.—Horse-tail family—a tribe of plants as represented by calamites.

*Era*.—The highest chronological division of geological history in the scheme proposed by the International Congress of Geologists and that of the U. S. Geological Survey; as the Paleozoic *era*.

*Erosion*.—The wearing away of rocks, chiefly by running water, but also by shore waves, glaciers, and winds.

*Ferruginous*.—Containing or having the nature of iron.

*Flexed*.—Bent, curved, or bowed.

*Foraminifera*.—A family of very minute shell animals, consisting of one or more series of chambers united by a small perforation or foramen. Examples: protozoans, radiates, mollusks. These characteristic species are subdivided through a wide range; for instance, the rhizopods are protozoans; polyps are radiates; brachiopods are mollusks.

*Ganoids*.—Fishes having the body covered with shining bony scales or plates, as in the garpike of existing waters, and hence named *Ganoid* by Agassiz, from the Greek word meaning *shining*.

*Gasteropods*.—Animals of the snail and slug species.

*Genera*.—Genus, race, kind, sort.

*Glaciers*.—Tongues or rivers of ice. Ordinary glaciers are accumulations of ice, descending along valleys from snow-covered elevations. They are ice-streams 200 to 5,000 feet deep, or more, fed by the snows and frozen mist of regions above the limits of perpetual frost. They extend 4,000 to 7,500 feet below the snow line (limit of perpetual snow) because they have such magnitude that the heat of the summer season is not sufficient to melt them an appreciable amount.

*Gneiss*.—A crystallized rock composed of feldspar, quartz,

and mica intimately intermixed, and having the mica foliated or disposed in parallel planes, producing a moderate tendency to cleavage into thick slabs; thus distinguished from *granite*.

*Graphite*.—This is simply carbon, neither lead nor iron occurring in the pure mineral. It is often called plumbago and black lead (the material of lead pencils), and looks like a metallic substance.

*Group*.—In stratigraphical classification of stratified rocks, the division next below the system or series: (1) In general usage, the chief subdivision of the system, in the ordinary application of that word, as the Chemung *group* of the Devonian system. (2) In the official usage of the U. S. Geological Survey, one of the chief subdivisions of a system (*system* being applied to the grander divisions of geological history), based mainly upon paleontological distinctions, but also upon structural separateness, as the Devonian *group* of the Paleozoic system (age). Under this usage *formation* replaces the word *group* in its more common application. (3) In the scheme proposed by the International Congress of Geologists, the highest stratigraphic division, corresponding with *era*, the highest chronological division.

*Gulf Stream*.—A great ocean current flowing from the Gulf of Mexico northward nearly parallel to the Atlantic coast of the United States, and turning eastward off Nantucket Island, its average rate being about two miles per hour. It plays an important part in ameliorating the climate of Great Britain and Norway. The similar Japan current, or *Kuro-Shiwo*, which gives a warm, moist climate to the lower Alaskan coast, is sometimes called the *Gulf Stream* of the Pacific.

*Heteropod*.—One of the family of gasteropods.

*In situ*.—In its original or proper site or position.

*Invertebrate*.—Not having a backbone.

*Laccolite*.—A mass of intrusive lava, which spreads out

laterally, at one or more points between strata, in lenticular

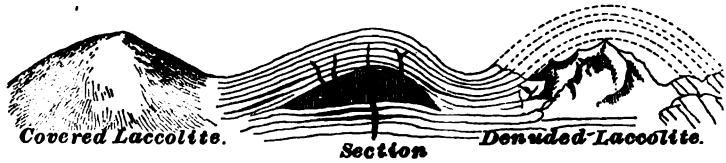

FIG. 389.

forms, lifting the overlying rocks into domes. (Fig. 389.)

*Lamellar*.—Composed of thin layers, plates, scales, deposited in layers like the leaves of a book.

*Lamellibranchs* (leaf-gills).—These belong to the mollusks. The valves of the lamellibranchs are right and left, while those of the brachiopods are upper and lower.

Silurian lamellibranchs are shown as Nos. 24, 25, 26, 27, and 28, Fig. 374.

*Lepidodendron*.—A genus of fossil trees of the Devonian and Carboniferous Ages, having the exterior marked with scars (see *K*, Fig. 381) produced by the separation of the leaf stalks.

*Lithostrotian*.—Large corals.

*Lycopod*.—A flowerless plant of the coal period. An acrogen.

*Mammals*.—Species suckling their young, a characteristic peculiar to the highest branch of the animal kingdom; breathing by lungs; having a heart of four cavities; as ordinary quadrupeds, with whales and seals.

*Marl*.—A clay containing a large proportion of carbonate of lime—sometimes 40 to 50 per cent. If the marl consists largely of shells or fragments of shells, it is called *shale marl*. Marl is used as a fertilizer, and other beds of clay or sand that can be so used are often in a popular way called *marl*. The “green sand” of New Jersey is of this kind. This green sand owes its peculiarities to a green silicate of iron and potash, which forms the bulk of it, and sometimes even 90 per cent., the rest being ordinary sand.

*Mesa* (pronounced masa).—A high, broad, flat table-land,

bounded, at least on one side, by a steep cliff rising from lower land; a plateau; terrace; flat-topped hill.

*Mica Schist*.—Consists mainly of quartz and mica, and some other minerals, and divides readily into slabs.

*Olenellus*.—See fossil No. 37, Fig. 374.

*Organism*.—A body composed of different organs or parts performing special functions that are mutually dependent and essential to life; an animal or plant.

*Pentremites*.—A genus of crinoids. (See *F* and *G*, Fig. 380.)

*Period*.—One of the larger divisions of geological time; as the Jurassic *period*. The geological application of the word varies with different authors. In the scheme of nomenclature proposed by the International Geological Congress, *period* is the chronological term of the second order, to which *system* is the corresponding stratigraphic term; as Silurian *period* or system. In the scheme of the United States Geological Survey, *period* has the same rank, but its corresponding stratigraphic term is *group*.

*Permo-Carboniferous*.—That epoch of the later Carboniferous formations called Permian.

*Placoids*.—Any fishes having plate-like scales similar to those on the shark.

*Polyyps*.—Marine animals with many feet or tentacles.

*Prehistoric Eras*.—Eras previous to even the most imperfect record of the history of the earth.

*Prismatic*.—Shaped like a prism.

*Prism*.—A form consisting of three or more intersecting planes whose intersections are parallel and vertical and whose bases have three or more sides:

*Protozoans*.—See definition of Foraminifera. Also Nos. 61, 63, 64, and 65, Fig. 374.

*Pteropods*.—Small animals which swim by means of wing-like appendages.

*Radiates*.—Having a *radiate* structure, like a flower, internally as well as externally; i. e., having similar parts



or organs repeated around a vertical axis. The animals have a mouth and stomach for eating and digesting.

*Shingle*.—A mass of loose rounded pebbles, coarser than ordinary gravel.

*Sigillaria*.—A genus of fossil trees principally found in the coal formations—so named from the seal-like leaf scars in vertical rows on the surface. (See *M* and *P*, Fig. 381.)

*Silica*.—Silicon, after oxygen, is the most abundant element, and constitutes at least one-fourth of the earth's crust. It is unknown in nature in the pure state; but combined with oxygen, and thus forming *silica*, it is common everywhere. This *silica* is an acid, although tasteless; and its combinations with alumina, magnesia, lime, and other bases (called *silicates*), along with quartz, are the principal constituents of all rocks except limestones.

*Spathic Iron Ore*.—See definition of clay iron-stone. Carbonate of iron is the ore of iron called *siderite* or *spathic iron*.

*Stigmaria*.—The generic name of certain forking roots, common in the older coal measures, supposed to belong to various species of *sigillaria*, etc. (See footnote, Art. 1354.)

*Talc Schist*.—Consists of quartz and talc.

*Trap*.—A dark colored eruptive rock frequently found in columnar structure, as certain basalts.

*Vertebrates*.—Animals, including men, mammals, birds, reptiles, and fishes which have a backbone, or vertebral column, containing the spinal marrow.

*Vice versa*.—The order or relation being reversed.

*Zoophytes*.—A general term, applied to simple polyps, and compound individuals consisting of many polyps united together, and the polyps resemble flowers in form.

The term formerly included sponges and corallines in addition to the above.

# PROSPECTING FOR COAL AND LOCATION OF OPENINGS.

---

## PROSPECTING.

---

### PRELIMINARY EXAMINATIONS.

**1383. Prospecting** is a practical application of geological knowledge for the purpose of determining whether coal or any other useful mineral may be found in any particular locality.

In prospecting for coal a *general* knowledge of all formations, and a *special* knowledge of coal-bearing formations, are required.

**1384. Preliminary Considerations.**—Before beginning to prospect extensively the following points should be considered: 1. Is the location of the tract such as to enable shipments to be made in an economical manner; that is, are there rail or water facilities immediately available, or, if not, is there a reasonable prospect of rail facilities in the near future? 2. What competition must be met in available markets, and what advantage, if any, will coal from the tract in question have in those markets? 3. Is there an abundance of labor near the tract, or can sufficient labor be brought there from other fields? If these questions, more particularly the first two, can be answered satisfactorily, the work of prospecting should begin.

**1385. Preliminary Work.**—Searching for coal in an unprospected region should first be done in a general way, and secondly in a more particular manner. The prospector should first go over the ground, carefully noting all

§ 12

For notice of the copyright, see page immediately following the title page.

prominent features, and gather all the general information possible regarding exposed rocks. If he finds evidence of rocks of the coal-bearing periods, either on the tract, or on adjacent tracts, he should decide on the best location of points from which a general approximate survey of the tract may be triangulated.

**1386. Approximate Survey.**—When no fairly reliable map of the region to be prospected is obtainable, one must be constructed. The survey for such a map can be most easily made by triangulation. To make a survey by triangulation the prospector must accurately measure as long and level a straight base line as possible. From each end of the base line, with his pocket compass, he must take a bearing to one of the points selected in the preliminary examination. He then has a triangle with two angles and the length of the included side, and he can readily calculate the value of the other angle and the lengths of the other two sides. The point of intersection of the two lines from the ends of the base line will mark the position of the object sighted to on the map. When the sights are taken to the first point, the prospector has *three* base lines on which to construct other imaginary triangles, completely covering the entire tract and as much adjacent territory as he wishes. Care should be taken to number each point from which a bearing is taken, and to use the same number in designating it, each time a sight is taken to it or from it. Having in this manner located all the prominent points, it is an easy matter to fill in the topography in an approximate manner. The map thus formed, though not quite accurate, will answer the purpose of the prospector.

**1387.** To make clear this method of triangulation, Fig. 390 shows an example of the work. In this instance the line 1 to 2 is assumed as the base line first measured, and its course due E and W, and its length as 600 ft. Then from the point 1 a bearing of N 50° E is taken to point 3, and N 10° W to point 4. Then from point 2 a bearing N 40° W to 3. Then from 3 a bearing S 80° W to 4. These bear-

ings plotted on the map will show the relative positions of points 1, 2, 3, and 4. Any number of other points may be located from any two of these. Care should be taken to secure sights from two points that will bring the angle of intersection between 25° and 150°, because with angles below 25° or over 150°, it is difficult to determine, on paper, the exact position of the intersection of the imaginary lines which marks the point sighted to.

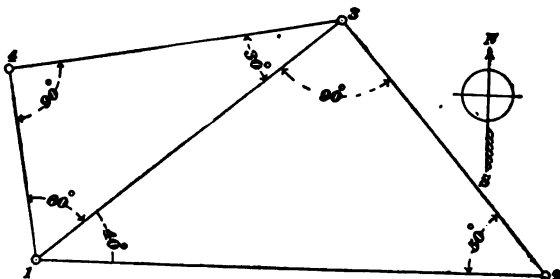

FIG. 890.

If it is desired to know the length of any of the bearings besides the base line, for the purpose of checking the plotting or for any other purpose, the following rule will be found convenient:

$$\left\{ \begin{array}{l} \text{Sine of the} \\ \text{angle opposite} \\ \text{the given side} \end{array} \right\} : \left\{ \begin{array}{l} \text{Sine of angle} \\ \text{opposite} \\ \text{required side} \end{array} \right\} :: \left\{ \begin{array}{l} \text{Length} \\ \text{of given} \\ \text{side} \end{array} \right\} : \left\{ \begin{array}{l} \text{Length of} \\ \text{required} \\ \text{side.} \end{array} \right\}$$

For example, if we want to find the length of the line 1 to 3, we have to work with the two angles of 40° at 1, and 50° at 2, and the included side 600 ft. long. As the sum of the three angles of all triangles equals two right angles or 180°, the angle at 3 = 180° - (40° + 50°) = 90°.

Then,  $\sin 90^\circ : \sin 50^\circ :: 600 : x$ , or  $1 : .7660444 :: 600 \text{ ft.} : 459.63 \text{ ft.} = \text{length of line } 1 \text{ to } 3$ .

In the same way we may find the length of line 1 to 4 by using the line 1 to 3 as the base of the triangle 1-3-4.

**1388. Keeping Prospecting Notes.**—The notes of the triangulation should be neatly recorded, together with all other data collected while making the triangulations, in a substantially bound note book. The rough or preliminary

map should be on as large a scale as is convenient. Thus, for a tract of land of two miles square, a scale of 400 ft. per inch would be as large a map as could be conveniently used in the field. For larger tracts a much smaller scale is ad-

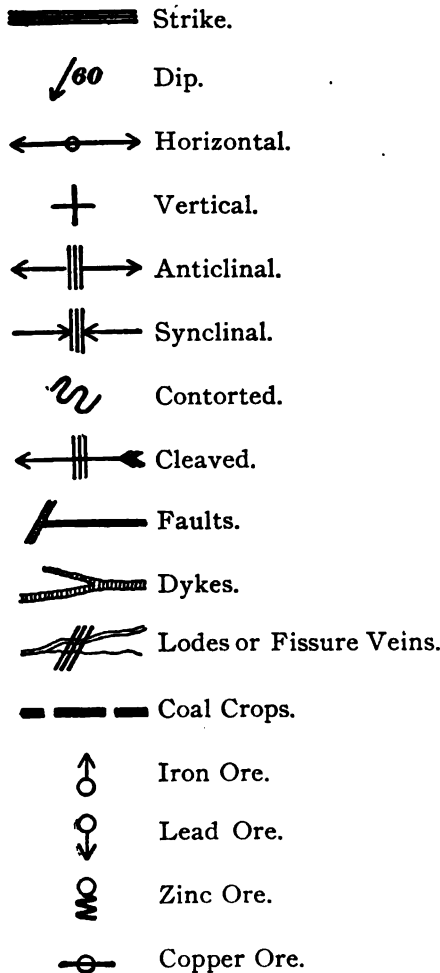

FIG. 391.

visable. This scale is so small that to make notes directly on the map, in the field, requires great neatness and care on the part of the prospector, and also the use of conventional signs to designate certain features, so as to prevent the confusion and illegibility of written notes. Fig. 391 shows a number of conventional signs most frequently used by prospectors.

### 1389. Object of First Examination.

—The first general examination of a tract is to determine the *character* of the rock beds. Their extent may be shown, approximately, on the map. Every care must be taken to determine rightly the relative ages of the beds, for on this the results of the prospect almost wholly depend. The

means by which the relative ages may be determined have been described in Economic Geology of Coal.

**1390. Evidences of Coal.**—The evidence obtained from the examination of the geological formations may be either favorable or unfavorable. If the preliminary survey shows that the rock beds are of the coal-bearing ages, it may be inferred that coal can be found. The presence of ledges of rock of the coal-bearing ages is presumptive evidence that coal can be found in their neighborhood. On the other hand, if the rocks are undoubtedly of other than coal-bearing ages, then there is practically no prospect of finding coal. As was stated in Economic Geology of Coal, coals are sometimes found in the Sub-Carboniferous, Devonian, and even as low down as the Silurian Age, but these are phenomenal cases. The most marked instance of coal being found below the coal measures occurs in France, at Drocourt, in the Pas de Calais. After sinking through the Cretaceous measures, the Devonian rocks were reached at a depth of 414 ft. After sinking in this foundation 544 ft., very disturbed coal measures and beds of coal, which were worked for a considerable time, were found. The shaft was deepened, and at 1,886 ft. a fault was struck. On passing through this fault the ordinary coal measures of the Carboniferous age were reached. In these measures coal, which is now being worked, was found. Evidently the Devonian and first portion of the coal measures met with had been *bent* completely over before the Cretaceous measures were deposited.

**1391. The Determination of Coal-Bearing Strata.**—The determination of the Carboniferous and later coal-bearing formations is often a matter of great difficulty, requiring long and careful observation. The prospector must never draw hasty conclusions from the absence of coal measures of the Carboniferous or other coal-bearing ages. The outcrop may be covered under more recent formations. (See Fig. 392.)

The general appearance that never deceives the eye in the older formations is not of much use to the prospector in some cases, on account of the readiness with which these

newer and softer rocks yield to the influence of the atmosphere. The cases may be further complicated by the pres-



FIG. 892.

ence of faults. When these complicated conditions exist, the only method of solving the question is by boring.

**1392. Second Stage of Search.**—When it is fully established that coal exists in a tract, or there is a very strong probability of it existing there, the second stage of the search is begun. It consists of a more thorough search for and closer observation of the rocks, and a thorough inspection of everything that might lead to the position and detection of the outcrop. It requires accurate surveys and maps, in case they have not been accurately made for the preliminary work. These surveys are required for the laying down on paper, in plan and section, of the true extent and position of the rock beds among which the coal seams occur. The prospector should carefully examine every exposed surface, especially "sections," such as may be found in railroad cuts, escarpments, quarries, wells, and banks of streams. A stream also carries mineralogical specimens obtained from places above where they are found. By ascending the stream and examining minutely the pebbles and sand in the bottom and on the sides, and noting where these fragments that indicate coal cease, a clue to the location of the bed of coal may be found. The approximate distance which these specimens have traveled will be indicated by the more or less worn condition of their edges, considered with relation to their hardness. Nodules of carbonate of iron and some

springs of water are indications of coal, both of which deserve attention. Pieces of shale washed clear of earthy matter should be carefully examined for indications of organic remains and vegetable impressions. Some grains of coal will be found in the stream if the coal crops out near it, and sometimes the rain will wash small grains from a considerable distance into the stream. In the latter case small grains, and even larger pieces, will be deposited along the route, by means of which the location of the parent bed may be traced. When fossils are found, great care should be taken in tracing them to their parent bed also.

---

### COAL-MEASURE TOPOGRAPHY.

**1393.** It was stated in *Economic Geology of Coal* that all coal-bearing formations consist of alternating beds of coal, shale, sandstone, etc., some of which yield rapidly to the disintegrating influence of the atmosphere. Coal is most affected; therefore, its outcrop should be looked for especially in depressions of the surface. If a depression is found following everywhere the direction of an exposed ridge of sandstone, it will probably be the outcrop of the seam.

The strongest topographical feature which denotes the presence of bituminous coal seams, where the seam lies above the bottom of the valley in hilly or mountainous districts, is easily recognized by any one familiar with the peculiarities of coal-measure topography. It is the terrace or bench\* which almost invariably occurs at the outcrop.

**1394. Terrace or Bench.**—Because every hard stratum will produce a terrace of some kind, it is necessary to have some means of distinguishing a coal terrace from a bench marking the outcrop of some other stratum.

In the bituminous coal regions of Pennsylvania, Tennessee, and other States, where the seams lie in the hills with a very slight dip, the site of a coal bed is nearly always

---

\*A terrace or bench is a flat surface running along a hillside, resembling in shape an old grass-covered roadway.



indicated by springs, whose waters carry iron in solution, which is deposited in yellow films upon the stones and vegetable matter over which they flow. In some parts of the State of Alabama, in the anthracite regions of Pennsylvania, and other places, the beds, being often highly inclined, rarely furnish such an indication of their presence, except in the sharply cut gaps and ravines eroded across the hills in which the coal occurs.

The coal terrace is generally a well-marked topographical feature, but in many localities the site of the outcrop is not marked by any distinct bench or terrace, and surface examinations fail to disclose any important feature. In tracing a coal terrace the breadth is always affected by

1. The thickness of the seam.
2. The dip of the seam.
3. The slope of the ground.

When the bed dips into the hill the bench is broader than when the pitch is in the opposite direction, and when the surface slope is gentle the bench is generally broader than when a steep hillside or contour prevails.

**1395. Direction and Strength of Dip.**—A good conception of the direction and strength of dip may be obtained by tracing a terrace for some distance and carefully noting its deflections from a straight line, and the relation of those to the contour of the ground. If the variation occasioned by a depression is towards the foot of the hill, the coal dips in the same direction with the slope of the ground, but if it runs in towards the top of the hill the reverse is true.

Having found a terrace which presents the appearance of a coal terrace, search is made on the bench, and also a short distance below the flat, for a positive indication of coal.

**1396. Coal Blossom.**—The blossom of a seam frequently is found to have slipped, and detached pieces or patches of outcrop blossom may be found at some little distance from the "full blossom," which is the continuity of

the seam. In the case of bituminous coal the blossom is a soft, black, sooty mixture of coal and clay.

Where the blossom has slipped, a prospect trench about two feet wide is advanced by stages into the hillside, as shown in Fig. 393. The trench may be started at any point below the bench where the prospector's judgment may indicate, or it may advantageously be started on the bench's level. If it shows no indication of coal after it has been advanced to the upper side of the bench (see *a*, Fig. 393),

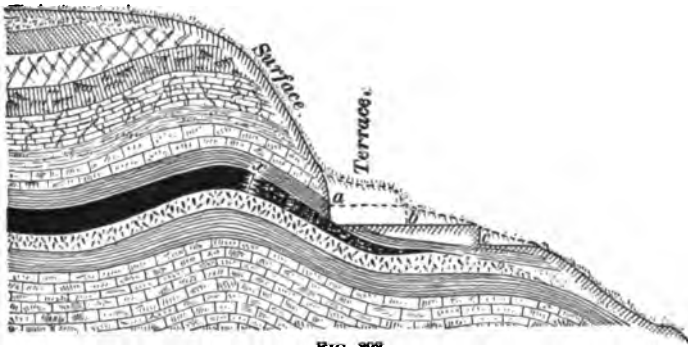

FIG. 393.

a second trench *b* may be started at a lower point and carried up to the place at which the first trench began.

In case the second trench, shown in the figure as *b*, proves barren, a third trench *c* may be started still further down the hill, and be driven up to the beginning of trench *b*. In like manner any number of trenches may be driven. If all the trenches prove barren, any one, as trench *b* for example, may be continued to the point where trench *a* was discontinued. If this trench should find the outcrop, a drift following the crop coal should be driven till the true coal is met at *x*.

It frequently happens that the lowest trench shows the blossom running up, in which case the trench simply follows the indications of coal, which grow stronger until the solid or full face of coal is shown. If only a trace of coal is found by digging these trenches, and the indications or judgment

prompt the prospector to go further into the hillside, the trench is turned into a *drift* by widening it so that a wheelbarrow or a car can be taken in. If these proceedings should give an unsatisfactory result, the trench, or it may be a drift now, should be turned into a prospect shaft and sunk until some trace of coal is reached. If, after sinking a reasonable depth, the result is still negative, it only remains to repeat the experiment at a higher or lower elevation on the hillside at some distance to the right or left of the first trench. The fact of having found no coal, or no trace of coal, is only proof that the material in which the former trench was made has been brought down from the hillside above by a landslide, sweeping before it all traces of the bed. This is very frequently the case with the outcrop where there is a bold escarpment or bluff above it, such as is present in the Cumberland mountains in the form of a conglomerate 20 feet to 80 feet thick, or more, overlying the shales covering the lower coal measures. The shale disintegrated, thus undermining the conglomerate to such an extent that it settled and slid down hill, pushing the strata overlying the coal away down the mountain. Sometimes this slip carried several yards of the seam of coal intact with it, which when first struck by the prospector was very misleading. Where surface indications "give out," a great advantage, which saves much money in locating the outcrop, is secured by running a line of levels from a point where the coal has been opened up to the point where another exposure of the coal is desired. If the coal has a dip, it should be taken into consideration when running this line of levels.

**1397. Presumptive Evidence of Coal.**—If the surface examination yields no evidence of the presence of coal other than rocks of the Carboniferous or later coal-bearing ages, the existence of coal in the tract is still probable, and boring is resorted to. But it is seldom necessary to bore holes to prove the near existence of coal, for, if the surface examinations are carefully made, unmistakable evidence of its presence will generally be discovered.

It must be distinctly remembered that coals which have an outcrop are now being discussed.

**1398. Influence of Slip of Blossom on Thickness of Bed.**—The creep, or slipping of the blossom, down hill, when *away from the bed*, will seldom cause the crop to present an exaggerated thickness in a prospect trench or shaft (see *a*, Fig. 394); but when the bed dips with the hill slope, the crop is usually overturned down hill, and the blossom is thus turned over on the outcrop (see *b*, Fig. 394). A prospect shaft sunk through such an overturned outcrop would deceptively indicate the presence of a bed much thicker than the actual measurement of the seam. The prospect shaft should, therefore, be sunk through the entire

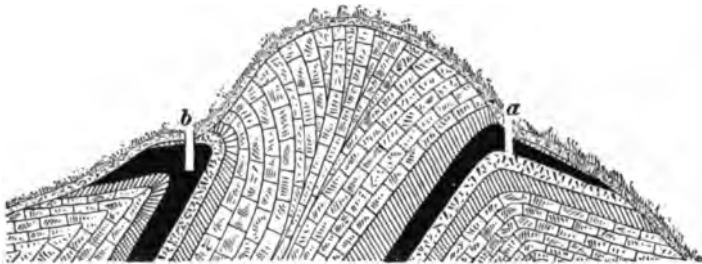

FIG. 394.

thickness of coal until the bottom clay or slate is reached, and then widened out horizontally, or a level should be driven at right angles to it, until the top rock is encountered. When two sets of cleavage planes cross the coal at nearly right angles, or where the outcrop is twisted and contorted by a creep or slide, it may be difficult to distinguish the roof from the floor, on account of the small area of the seam exposed in a prospect opening, and the direction of the dip remains uncertain. The occurrence of *stigmaria*—the roots of *sigillaria*—in one of the rock walls of the seam is presumptive evidence that the stratum containing them is the bottom of the seam. But if *sigillaria*, fern leaves, etc., are found, the rock is probably the roof or top rock, although both of these fossil plant remains may occur in either the roof or bottom of a coal seam.

When the seam has a strong dip and outcrops on a steep hillside, the prospecting shaft may advantageously be replaced by a tunnel.

**1399.** It may be remarked here that frequently coal diminishes in thickness at the crop so that a 3 or 4 foot seam may diminish to a mere black line at the crop. The reverse is also true, for seams having an outcrop from 3 to 4 feet thick sometimes diminish to a mere black streak between two rocks.

The outcrop of a coal seam may often be detected on the surface, by a line of blackish soft material. The coloring is due to the disintegration of the coal and the deposit of soil mixing with it and covering the coal.

In noting the dips of the various strata exposed at the surface, the prospector must be cautious not to be deceived by false dips. Along the banks of rivers and ravines, the crop of coal in nearly flat areas sometimes has a slight dip inward, continuing only a short distance under the surface, disappearing on reaching normal conditions.

Landslides are to be carefully looked for where the coal crops out on hillsides, as they are liable to give wrong impressions regarding the seam and its dip, etc.

The confusion of strata resulting from plication must be thoroughly understood; otherwise, a wrong conception of the order and number of seams would be obtained. See *Economic Geology of Coal*.

The undulation of the surface, in many cases, is a true indication of the seam underlying, if the depth is not great, and the distance is not disturbed by throws. The depressions on the surface represent local swamps in the seam almost vertically under the surface depression.

**1400. Disturbance of Coal Formations.**—In a great many coal fields where a considerable disturbance has taken place, the continuity of the strata is broken by faults in regular succession. (See Fig. 395.) In others the strata may be turned up for a considerable distance at its outer

edges. Thus, we have long slopes ending in long horizontal

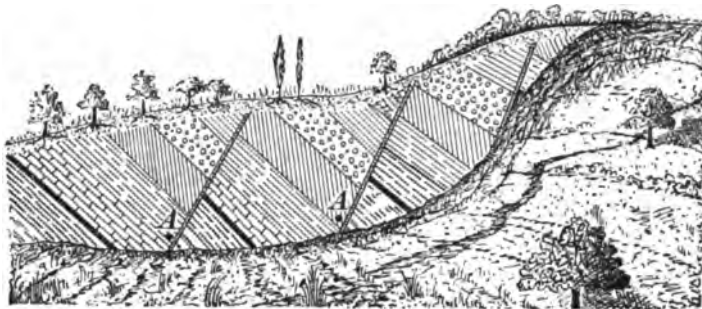

FIG. 395.

gangways, which in turn give way to rising headings or a slope from the opposite side. (See Fig. 396.)



FIG. 396.

**1401. Oblique Lamination.**—In measuring the dip care must be exercised that oblique lamination, cleavages, or other indications of cross-fracture, and layers displaced by the growing roots of trees, are not mistaken for the true dip of the seam.

**1402. True Dip.**—While studying the rock bed, the true dip must be carefully determined. There is a great advantage in being able to get a full view of a bed of rocks, inasmuch as the true position of any one of these rocks, when met singly, as well as the position and thickness of the others, if they are not exposed, may be inferred. Every change of the dip deserves attention regarding amount, direction, etc. Such change may be only local, or superficial, instead of belonging to the great and regular bending of the rock. When one fold dies out and another begins at the same time to rise on one side or the other,

there will be, as a consequence, transverse strikes of the strata over the district between the approximate ends of the two folds.

When the character and dip of a rock bed have been fully established, its boundary should be laid down on the map.

It will be inferred from what has been said in Economic Geology of Coal in regard to rocks changing from sandstone to shale, etc., that the bed may also thin out or change its composition or color. Such changes are not signs of new beds.

**1403. Identification of Rocks.**—The prospector is better equipped for his duties if he has a knowledge of mineralogy, but in the absence of such knowledge rocks may be distinguished to some extent by their physical properties, such as color, etc.

**1404. Streak.**—Streak is the name given to the powder made when a knife, or file, or diamond is drawn across the surface of a rock, etc. Streak is sometimes useful in distinguishing dark bituminous clays or shales from varieties of coal, the former giving a dull brown or gray powder and the latter a lustrous black.

**1405. Color.**—Within *certain limits*, some, at least, of the constituents will be indicated by the color. The great coloring matter to which rocks owe their diversities of hue is iron. It gives rise to numerous tints of yellow, brown, red, green, blue, and black.

Frequently we meet limestones and clays which are quite *white*, in which condition they are nearly at their purest. Iron is present only in very small quantities, or is absent altogether. Weathering often results in bleaching the rocks white, the air and rain removing the coloring materials, especially the iron.

Coals, of course, may be distinguished by their lightness, texture, and combustion. Clays or shales rendered black by the vegetable matter they contain may be recognized by their weight, streak, and their turning white, but re-

taining their shape when strongly heated. But black heavy rocks abound *in which there is no trace of carbon*. These generally contain a considerable amount of iron. Such rocks are apt to weather with a brown or yellow crust.

Some rocks are characterized by a *brown* color on fresh fracture, for example, black-band iron-stone. Some mica and garnet and other crystalline rocks have a brown tint due to the presence of mineral of that color. Brown tints appear more particularly on the decomposed surface and crust of rocks.

*Gray* may be said to be the prevailing color among rocks, especially of the older geological periods. In simple rocks, like limestone, it is often produced by the intermingling of minute particles of clay, sand, or iron oxide, or of carbonate of lime. Pure crystalline limestone is naturally snow white, as in Carrara marble. In compound rocks the prevailing gray hues depend on the mixture of the white mineral, usually a feldspar, with one or more dark minerals, the lightness or the darkness of the hue depending upon the relative proportions of the constituents. Should the feldspar be colored by iron, a pinkish hue may be given to the gray; or, if the dark magnesian silicates have been chemically changed, the gray becomes more or less distinctly green. The old "green stones," probably originally gray, often owe their present distinctive hue to an alteration of their original minerals.

*Blue* is infrequent in rock masses. Limestones are really gray, or bluish-gray; nevertheless, blue is the color often spoken of as the color of limestone. In schistose rocks a belt of pale blue and white sometimes occurs. Some clays are of a pale lavender hue. Among peat mosses, patches of an indigo tint are frequently met, resulting from the decay of some organism which gave rise to the formation of phosphate of iron.

*Green* is due to the reduction of iron oxide. Many red sandstones are marked with round spots of green. Carbonates of copper sometimes color rocks a bright verdigris or emerald-green tint. Many magnesian silicates are green



and impart green colors of various hues to rocks of which they are constituents.

Oxide of iron is nearly always the coloring material of *yellow* rocks. Weathered crusts of many limestones, numerous ferruginous crystalline rocks, beds of ocher, and yellow sandstones furnish illustrations. A metallic or brassy yellow is sometimes communicated to parts of rock by diffused iron pyrites.

**1406. Smell.**—Some rocks, especially limestone, containing animal matter or decomposing iron sulphides, yield a fetid or rotten-egg odor when freshly broken.

**1407. Geological Horizon.**—As it is impossible to represent the outcrop of every bed on an ordinary map, the prospector must decide what bed should be selected for tracing. Sometimes this outcrop can not be selected until considerable progress has been made. The selection of an outcrop does not depend merely on the geological or industrial importance of the stratum, but also upon the extent to which it is exposed, and can be followed across the district. A peculiar stratum of no special interest in itself may have a high importance as a geological bench or platform, or horizon, if it is easily recognizable, and, from its thickness, hardness, or other peculiarities, stands out so prominently that it can be satisfactorily traced from point to point. Such a stratum may be found in most districts of stratified rocks. Great assistance in the tracing of benches is likewise afforded by organic remains. A particular stratum, even when thin and otherwise of no apparent importance, may acquire a high value if it is charged with fossils and can be recognized over a wide area.

**1408. Breadth of Outcrop on Plan.**—The outcrop may be marked on the plan at any particular locality by a short line and the dip-arrow, or, if the outcrop is a broad one, by two lines, one marking the base and the other marking the top of the stratum. The space between these two lines (in other words, the breadth of the outcrop) is determined by the thickness of the bed, its angle of inclination, and the slope or contour of the ground.

**1409. Continuity of Coal Beds.**—When the outcrop is clearly shown, but the coal extends under a more recent formation, there should be no question of the existence of coal under the ground covered by these latter formations, unless some indications of volcanic eruption, or a heavy throw, are found, which may have thrown the strata to a great height. These strata, with the coal they contained, may have been then denuded and planed down, leaving a large area of upturned rocks in which there is no coal. Again, although the coal may be continuous through the whole area, a down-throw fault may have broken the continuity of the strata and thrown the coal measures to an enormous depth. The Whin Dykes, of Scotland, in many cases, throw the coal up or down several hundred feet, and also change the strength of the dip.

Under these circumstances a knowledge of geology may and will help us, but a positive knowledge of the depth of the seam, its dip, etc., can be obtained only by boring. There are exceptions to the continuity of the coal under the overlying measures. In some seams in Western coal fields which outcrop in the beds of rivers nearly 300 feet deep below the level of the prairie, the coal continues under the prairie for miles, broken only by small throws, and then becomes more and more bony, then slaty, and finally changes to pure shale at a depth nearly level with the outcrop.

**1410. The Accurate Survey and Map.**—The construction of a temporary map has previously been explained, but now, if a more complete map can not be procured, one must be made. A convenient scale is 400 or 500 ft. to the inch, but the size of scale is not of much importance further than that a large plan is unwieldy, while one of small scale requires greater care on the part of the prospector when putting his notes or signs on the map. All the spots where any information can be had regarding the formation must be carefully marked or located on the plan *within the space they occupy*.

The surface survey of any tract of land, shown by the

preliminary survey as likely to contain workable coal, may be made by triangulation. The ground is covered with a network of imaginary triangles, all the angles of which have been measured by placing the transit at each station and noting the angle that the lines make with each other. When the length of the base line and the angle at each end are known, the length of the other lines can be calculated by the rule given in Art. 1387:

$$\left\{ \begin{array}{l} \text{Sine of the} \\ \text{angle opposite} \\ \text{the known side} \end{array} \right\} : \left\{ \begin{array}{l} \text{Sine of the} \\ \text{angle opposite} \\ \text{the required side} \end{array} \right\} :: \left\{ \begin{array}{l} \text{Length} \\ \text{of known} \\ \text{side} \end{array} \right\} : \left\{ \begin{array}{l} \text{Length of} \\ \text{required} \\ \text{side.} \end{array} \right\}$$

EXAMPLE.—It is supposed the base line  $1-2$  when measured was 600', and the transit when set up at  $1$ ,  $2$ ,  $3$ , and  $4$  gave the angles as

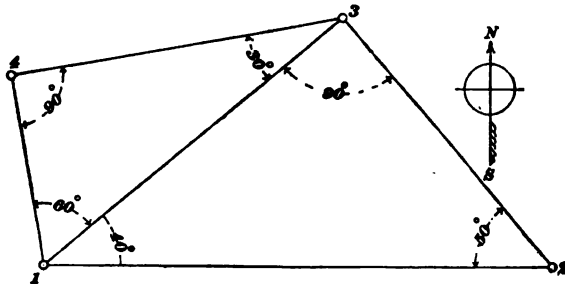

FIG. 897.

they are marked on Fig. 897. What is the length of  $1-3$ ?

SOLUTION.—Applying the above rule:

$$\begin{array}{l} \text{Sine of } 90^\circ. \quad \text{Sine of } 50^\circ. \\ 1.0000 : .766044 :: 600' : 459.63 \text{ feet. Ans.} \end{array}$$

EXAMPLE.—What is the length of  $1-4$ ?

SOLUTION.—

$$\begin{array}{l} \text{Sine of } 90^\circ. \quad \text{Sine of } 30^\circ. \\ 1.0000 : .5 :: 459.63' : 229.81. \text{ Ans.} \end{array}$$

In order to get good results the decimal figures should be carried to at least five places. The first operation, as intimated before, is in selecting the base line. This need not exceed 900 feet in ordinary surveys, if it is carefully and accurately measured. One of the sides of the last triangle should be measured, if the survey is a large one, to check the calculated lengths, and to prove the accuracy of the survey.

The end of the base line should be carefully marked by some prominent object, such as a piece of heavy T rail, or an old car axle, when obtainable, about 3 feet long, driven into the ground, the "point of sight" being carefully marked by a cross (+) mark; or a large-sized stone may be sunk in the ground and a hole drilled in the same at the "point of sight."

Special care must be taken to avoid ill-conditioned angles, that is, triangles should be avoided with angles less than  $30^\circ$  or more than  $120^\circ$  to  $150^\circ$ , because a point is not absolutely defined if the lines fixing it meet at a very obtuse or very acute angle.

The completion of a survey by triangulation is accomplished by the "filling in" of the interior details by surveying, with the transit or compass, the rivers, roads, woods, streams, etc.

**1411. Preservation of Notes.**—All notes should be carefully preserved either on the plan constructed for the prospector's final examination, or, what is better, in a substantially bound book, so that should the examination of the property develop sufficient facts indicative of successful mining, a working map or colliery plan can be constructed from them.

In order to show the application of what has been said in the preceding articles, two diagrams are given (Figs. 398 and 399).

**1412. Prospector's Map.**—In Fig. 398 is shown the manner in which data is compiled and recorded on a prospector's map. The shaded parts show what is actually seen by the prospector; over the blank portion he is supposed to have been unable to see any rock in place.

Most all the observations occur along the streams, these being the most frequent natural lines of section. At each point where the dip has been taken an arrow and number mark the direction and angle of dip. The more important or stratigraphically serviceable beds have their outcrops marked in decided lines where actually seen. The outcrop,

where the same stratum can be seen in two adjacent streams, may be drawn across the intervening ground, and the intervening ground should be searched for corroborative indica-

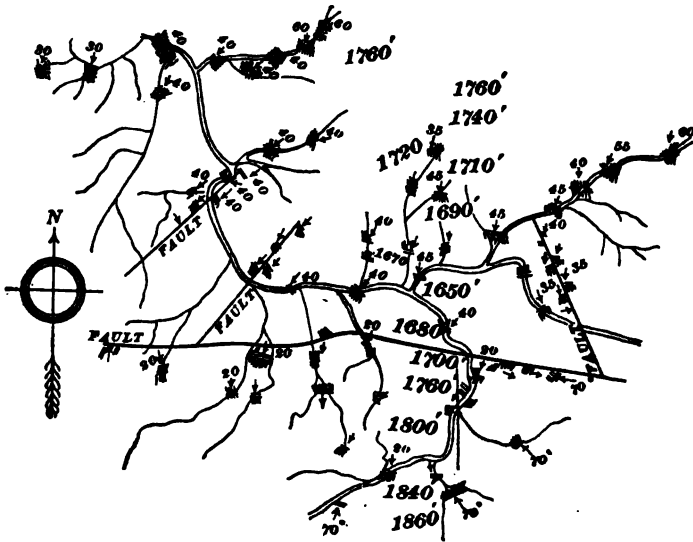

FIG. 398.

tions. The outcrop may be drawn in continuous lines on the plan where there is no doubt regarding its position and direction, but where any doubt exists regarding these points it must be indicated only by dotted lines.

**1413.** Fig. 399 shows a complete geological plan constructed from the prospector's notes shown on Fig. 398. It will be noticed that the order of succession of the rocks is found to be the same in the different streams. Bed *a*, after an interval, is followed by *b*, *c*, *d*, *e*, *f*, and *y*, but at *h* a fault is met, which throws the stratum *a* to the position shown at *i* (see map and section), which, after an interval, is followed by *j*, *k* (*j*, *k* are the same beds as *b*, *c*), but at *l* something different is met, viz., the same rocks dipping in the opposite direction. The result is plainly shown in section, Fig. 400. Where a blank space occurs, and owing to some surface accumulations a certain bed may not be visible to the pros-

pector in one of the lines of the section, the position of the invisible stratum may reasonably be assumed. In such a case dotted lines are drawn to indicate its probable position.

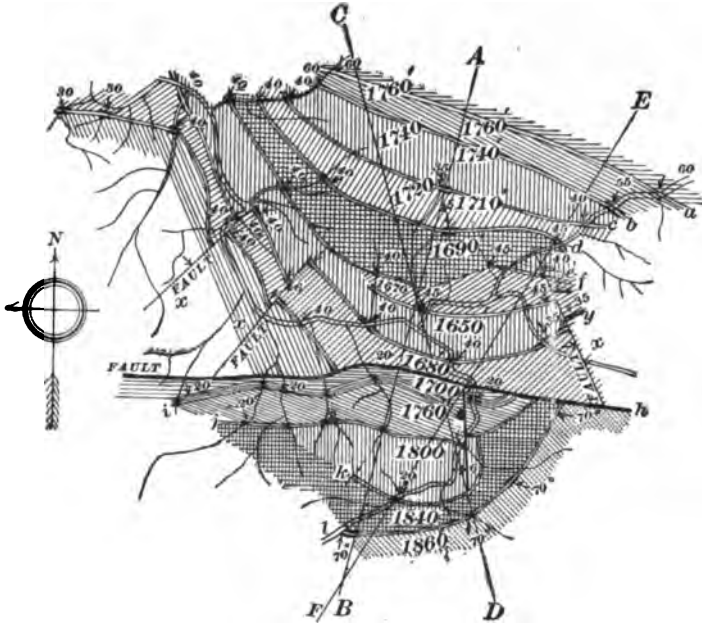

FIG. 399.

A prospector's geological map is therefore constructed from actual data, and from legitimate inference.

**1414.** In Fig. 401 are shown a few of the conventional characters used by geologists for sections and diagrams when colors are not admissible.

**1415. Change of Outcrop.**—It will be noticed that although the stratigraphical order is the same in each stream the lines of outcrop differ greatly, diverging and converging as they are influenced by inequalities in the level of the ground, or by variation in thickness of strata, or by variation in angle of dip.

There is still another condition that may influence the stratigraphical order, viz., thinning away of the strata

(Fig. 402). A section is sometimes found where the two lines of outcrop come together, caused by the complete thinning away of the intermediate strata. In this case the

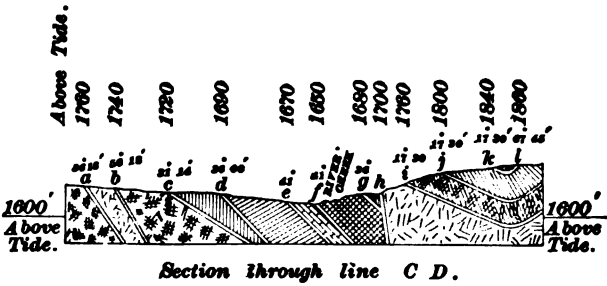
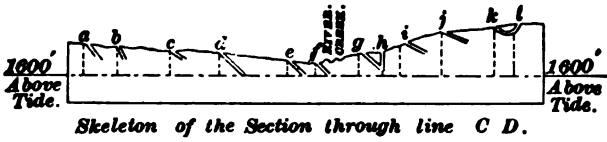
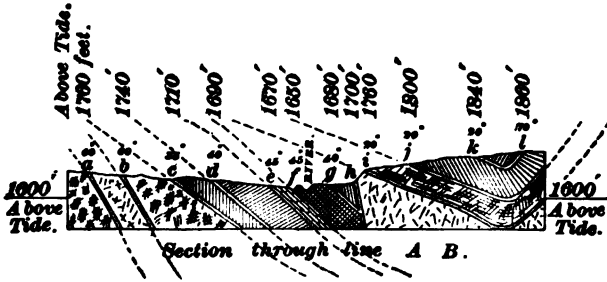
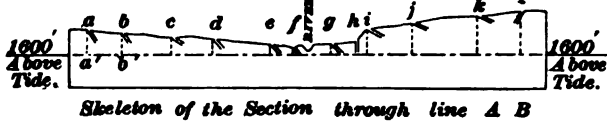

FIG. 400.

conjoining outcrops may be traced for a long distance without any change. The higher portions of a series of strata now and then steal or lap over the lower.

Such a formation can not always be shown on the map, but it is made clear by a section. This structure (see Economic Geology of Coal) may frequently be met with along

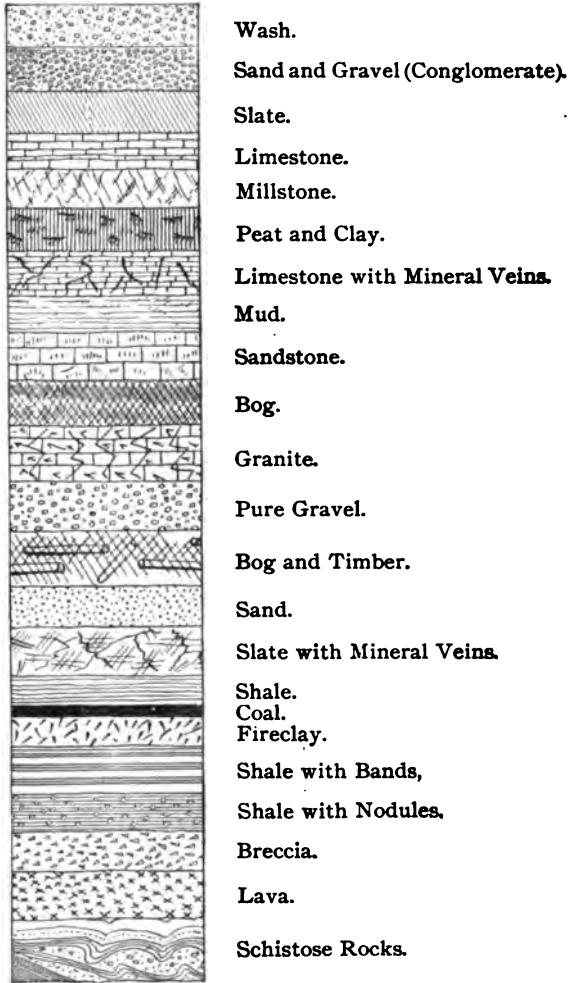

FIG. 401.

the margins of formations deposited in tracts which were undergoing gradual submergence. The strata are parts of one continuous and unbroken series. As the land sank,



successive formations were carried down beneath the sea, and the later deposits of the sea floor were prolonged

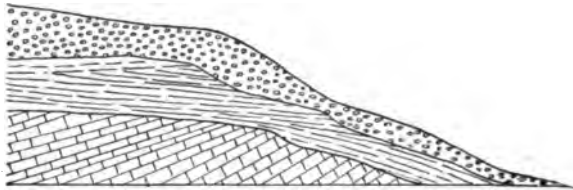

FIG. 402.

further and further beyond the limits of the earlier one. No apparent unconformity can be detected between any portions of them. But where the accumulation of a group has been succeeded by elevation, exposure, and denudation, the next set of strata laid down on this disturbed and denuded group will rest upon it unconformably.

**1416. Faults; Dykes.**—Intrusive rocks may occur in the form of veins, traversing at any angle the rocks among which they rise, in the form of wall-like masses or dykes, or as irregularly circular masses forming the upper ends of vertical columns or pipes called “necks.” Dykes vary from less than an inch in thickness to over 70 feet, and often carry iron which attracts the magnetic needle to such an extent that the dykes can frequently be traced long distances by that means.

Fig. 398 shows several faults, but they are all from the same parent bed. Unless very carefully examined, a minor fault or secondary slip or dislocation may be mistaken for an important and dominant fault, the evidence of which might be elsewhere obtainable, but which might never be seen itself. An exposure of a fracture will give the exact position of the line of fault at that place, but it is not necessary to prove the existence of either the minor or dominant fault, nor will the exposure furnish additional information of any value or importance. As a rule the large faults which powerfully affect and influence geological structures are seldom found in any visible form. In this way three

faults are shown in Fig. 395, yet none of them show any surface indications. Indeed, in many cases, a fault is a line of weakness readily attacked by the forces of denudation, whereby it is hollowed out so as to become a receptacle for superficial deposits which actually hide the fault from view.

**1417. Springs Due to Faults.**—A spring of water is often due to a fault diverting an underground current of water from its course. The rocks having open joints will conduct the rainfall that reaches the outcrop down to the valley, but a fault crossing the strike throws the rocks up and substitutes a bed impervious to water. The water, being unable to flow downwards to the bottom, finds its way through the covering of clay and soil, and bursts out on the hillside in springs *A, A*, Fig. 395. There are many other indications of faults which will present themselves to the prospector, but by far the most important and satisfactory evidence of the existence and effects of faults is furnished by the grouping of the rocks with reference to each other. The nature of this evidence will be most satisfactorily shown in plan in Fig. 399, and in section in Fig. 400. The plan, Fig. 399, and section, Fig. 400, show that the strata found at *a* have been thrown to the surface and are again shown at *i*, which proves that a fault of great proportions (not necessarily wide) exists at *h*.

**1418. Dip and Strike Faults.**—Faults running with the dip are called "dip-faults" (*x, x, x*, Fig. 399), while faults running with the strike are called "strike-faults" (*h*, Fig. 399). A dip fault has the effect of shifting the outcrop of an inclined stratum so as to make it appear as if it were horizontally displaced, owing to the way in which denudation has worn down the surface of the ground. In the map (Fig. 399), the beds *f* and *y* are dipping south, and are traversed by dip-faults with a downthrow to the east. The lines of outcrop are consequently shifted northwards on the downthrow side. If the beds had dipped northwards, then a downthrow to the east would have moved the outcrops southwards. A strike fault, when it exactly coincides with

the line of strike on both sides, makes no change in the line of outcrop, except in bringing two different parallel formations closer together. It may, however, carry important strata (coal, for instance) out of sight, or prevent them from being seen at the surface. Thus all the strata under *a* (Fig. 399) can not be seen at the fault, although it crops out north of *a* on the map.

A dislocation may occur in any direction, and cross either dip or strike at any angle; therefore, the dip fault and strike fault are not very sharply marked off from, but may pass into, each other. A fault is generally designated by the direction it throws from the place first met in mining. Thus, if the strata have dropped at the place the fault is first met it is a downthrow, if the strata have been thrown up it is an upthrow.

**1419. Thrust Fault.**—Dislocations sometimes assume the form of inclined or undulating planes, the rocks above having been pushed over those below by lateral pressure. In such cases, the horizontal displacement is very great. This is sometimes termed an overthrust.

**1420. Advantages of Sections.**—Some clearly constructed maps do not need any section, except to show data which can not be expressed on the map, as some cases of overlap. But such clear maps can seldom be constructed. Clearly constructed sections save both time and labor, as they enable the structure of the district to be seen and comprehended almost at a glance.

**1421. Horizontal and Vertical Sections.**—Two kinds of sections are made, horizontal and vertical. They may show what would be seen if a deep trench were cut across the hill and valley so as to expose the relation of the rocks to each other; or they may exhibit the arrangement and thickness of the rocks as they would appear if piled into a tall column one above the other in their proper order of succession. This latter section is chiefly useful in detail work among coal fields where the various strata of one pit, or a part of a district, may be compared with those of

another. This class of section requires good exposures and careful measurement.

The construction of the horizontal section is different. It may be necessary to construct a section of a district where exposures are few, where minute measurements are impossible, and where the best skill of the prospector is required to unravel the meaning of the facts noted upon the surface, and show their bearing on the rocks below ground. A section of this kind should be constructed so that the heights and lengths are on the same scale, if possible. When the ground is comparatively level, to use a scale large enough to show the elevations and depressions would make the section exceedingly long on paper. In such a case it would be best to use a larger scale for the vertical heights than for the horizontal distances, but exaggerating the height of the section should be avoided as much as possible.

Sections are generally drawn at right angles to the strike, but in special cases, to make clear certain formations, they may be drawn at any angle from the strike.

**1422. Section and Curvature of Strata.**—Having obtained the elevations of the points on the surface through which the section runs, the next step is to lay off on a base line, or datum, measurements to scale, showing the horizontal distances between the points. From these points on the datum perpendicular lines must be drawn, and the height of each point marked by scale on its perpendicular, as in skeleton section of Fig. 400. A line is then drawn connecting all the points. This gives the general contour of the ground. More details can be secured by taking the skeleton section in hand and walking over the ground, filling in all little inequalities of surface. This may also result in securing more evidence as to the nature and structure of the rocks. Some of the data for such a section may be secured in places at some little distance from the actual line of the section. The skeleton section (Fig. 400) shows what is exposed to the view, while the complete section is constructed from these exposures and the logical inferences that

TABLE 29.  
OBLIQUE SECTIONS.

$b =$	5°	10°	15°	20°	25°	30°	35°	40°	45°	50°	55°	60°	
	<b>Corrected Angles.</b>												
$c = 5°$	4° 59'	9° 58'	14° 57'	19° 56'	24° 55'	29° 50'	34° 54'	39° 51'	44° 53'	49° 54'	54° 54'	59° 54'	
$c = 10°$	4° 55'	9° 51'	14° 47'	19° 43'	24° 40'	29° 37'	34° 35'	39° 34'	44° 34'	49° 34'	54° 35'	59° 37'	
$c = 15°$	4° 50'	9° 40'	14° 31'	19° 22'	24° 15'	29° 09'	34° 04'	39° 02'	44° 00'	49° 01'	54° 04'	59° 08'	
$c = 20°$	4° 42'	9° 25'	14° 08'	18° 53'	23° 40'	28° 29'	33° 21'	38° 15'	43° 13'	48° 14'	53° 18'	58° 26'	
$c = 25°$	4° 32'	9° 05'	13° 39'	18° 15'	22° 54'	27° 37'	32° 24'	37° 15'	42° 11'	47° 12'	52° 19'	57° 04'	
$c = 30°$	$a =$	4° 20'	8° 41'	13° 04'	17° 30'	22° 00'	26° 34'	31° 14'	36° 00'	40° 54'	45° 54'	51° 03'	56° 18'
$c = 35°$	...	4° 06'	8° 13'	12° 23'	16° 36'	20° 54'	25° 19'	29° 50'	34° 30'	39° 19'	44° 56'	50° 20'	54° 49'
$c = 40°$	...	3° 50'	7° 42'	11° 36'	15° 35'	19° 39'	23° 51'	28° 16'	32° 44'	37° 27'	42° 25'	47° 34'	53° 00'
$c = 45°$	...	3° 32'	7° 06'	10° 44'	14° 26'	18° 15'	22° 12'	26° 21'	30° 41'	35° 16'	40° 07'	45° 17'	50° 46'
$c = 50°$	...	3° 13'	6° 28'	9° 47'	13° 10'	17° 28'	20° 52'	24° 14'	28° 20'	32° 44'	37° 27'	42° 33'	48° 05'
$c = 55°$	...	2° 52'	5° 46'	8° 44'	11° 47'	14° 58'	18° 19'	21° 53'	25° 42'	29° 50'	34° 21'	39° 19'	44° 59'
$c = 60°$	...	2° 30'	5° 02'	7° 38'	10° 19'	13° 07'	16° 06'	19° 17'	22° 45'	26° 34'	30° 27'	35° 32'	40° 54'

may be made. Along the limited exposures of strata usually visible, the planes of dip often seem to be straight lines. Bed succeeds bed, inclined, and forming a succession of parallel bands. But if the section could be continued downwards beneath the surface, or the rocks exposed on the bare steep side of a great mountain, it would be observed that though, when examined within the limited area of a few yards, the beds look as if they sloped in straight, stiff lines, in reality they are portions of great curves, as shown by dotted lines in Fig. 400.

An exact method, however, of determining the underground curves from surface dips can not be devised, and in the absence of exploratory bore holes, the depth and curvature of a coal or other mineral bed can be indicated only approximately, and by very imperfect methods.

**1423. Oblique Section.**—In order to draw an oblique section, such as a section through line *CD* in Fig. 399, the necessary correction of the true dip must be made by means of the following formula:

*a* = tangent of angle of corrected dip;

*b* = angle of dip at right angles to strike;

*c* = angle at which the section lies to right, or left, of the full dip.

$$a = \tan b \times \cos c. \quad (84.)$$

**EXAMPLE.**—Angle of dip is  $45^\circ$ , and the oblique section line runs at an angle of  $80^\circ$  from the true dip; what will be the dip on line of oblique section?

**SOLUTION.**—Tan of  $45^\circ$ , or 1.0000,  $\times$  cos of  $80^\circ$ , or 0.866 = 0.866 = tangent of  $40^\circ 54'$ . Ans.

The accompanying table of Oblique Sections, calculated from the above formula, gives the correction for the most useful angles.

**1424. Boring and Trial Shafts.**—By referring to Fig. 403 (which is a section showing anticlinal and extension of coal field, entirely concealed by new formations, only discoverable by boring), it will be seen that surface exposures, although of great value to the prospector because

they lead up to logical conclusions, are not all-sufficient. Under such circumstances as indicated on the right of Fig.



FIG. 408.

403, and many other conditions, recourse must be had to trial shafts and boring in order to get the necessary data to complete the map, so that it will be in shape to indicate conclusively at which point the openings may be most advantageously and economically located.

A shaft will show the ground more plainly than a bore hole, but the cost of sinking beyond shallow depths bars it out. A prospect shaft seldom exceeds 200 feet, and cases where it reaches this depth are exceedingly rare. Apart from the consideration of cost, the consideration of time is all important. Prospecting by drilling is more rapid. When the property, however, has been drilled and otherwise thoroughly investigated, a trial shaft should, when practical, be sunk to prove the quality of the coal, the nature of the roof and bottom, etc. Boring, while proving the *existence* of coal, can not give an adequate knowledge of its commercial value. This can be secured only by driving into the seam sufficiently far from the surface to get a good average sample of the coal.

Some seams are so largely made up of bony coal and other inferiorities that in appearance are like good coal that boring does not always afford reliable data, and when the shaft is sunk to develop the coal it turns out unsalable.

The experience of the past few years in coking Appa-

lachian coals affords assurance that their coking properties can be estimated with a good degree of confidence by the ratio of volatile hydro-carbons to the fixed carbon. Nevertheless, it is only by practical tests that any coal can be properly judged as to its coking properties, and the value of the coke for metallurgical and other uses.

Thick seams, reported as having been proved by boring, sometimes turn out on investigation to be largely made up of more or less thick layers of worthless materials interstratified with good coal.

A drill furnishing a core is less liable to deceive in this respect than those which furnish only ground samples fished out by a sludger, cleanser, or sand pump.

Coal seams are sometimes practically valueless, owing to the roof being so rotten or dangerous, and so expensive to maintain or carry, that the coal can not be profitable mined.

In some cases it may happen that the overlying strata contain so much water, or are so loose and sandy, that mining operations beneath are quite impracticable. A better idea of these conditions is obtained by sinking a trial shaft or drift and driving a heading or two into the seam.

The strata of some districts contain so much water that it is necessary to have the first shaft sunk large enough to facilitate putting in large pumping fixtures. In such a case the prospect shaft should be carefully located and of such size that, should the coal be workable, it may be used as one of the principal openings in the future development.

**1425.** The two chief methods of boring are:

1. By percussion drill, which chips the rock into small fragments, subsequently removed.
2. By a rapidly revolving ring, which grinds the rock in an annular space into dust.

The machines classed under the above headings will be described later.

**1426. Systematic Record of Details.**—The systematic recording of all details in a prospect is the most important part of the whole proceedings. Cases are on record where a district was prospected by boring, twice







$2.5 = \cotangent\ of\ 21^{\circ}\ 48'$ , which practically agrees with the clinometer reading at *A*.

If the result did not agree with the pitch shown by the clinometer on the rocks at *A*, then there must be a fault between or the dip has changed in strength.

How far must the line *AB* be extended beyond *B* so that a drill hole will strike the stratum *A* at the same depth it is in the bore hole at *C*, the surface being level?

468 feet (depth of hole *C*) — 380 feet (depth of hole *B*) = 88 feet. As there are 3 feet in length for every foot in depth along line *AB*, all that is necessary is to multiply 88 feet by 3 feet, resulting in 264 feet as the length *AB* will have to be extended to reach the same depth as bottom of the hole at *C*.

In the same manner the true dip may be found by three bore holes, where there are no exposures whatever. It is only right to say that these calculations are often upset by faults running between the positions of the bore holes.

**1429.** Another case is shown in Fig. 405. In the north river seams crop out at *A*, *B*, and *C*.

The thickness of each seam and the nature of the strata over and underlying each must be carefully noted. By the

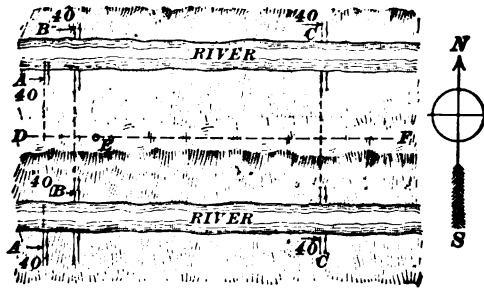

FIG. 405.

aid of the clinometer the dip of the measures is obtained, and by the pocket compass the "strike" or level lines of the seams are found to run in the direction of the dotted lines from the north to the south river. Following these lines to the south river, the same seams are found cropping out at

*A*, *B*, and *C*. By drawing the lines from *A* on the north river to *A* on the south, the probable outcrop of that seam is shown. The same will be true of the other two seams.

This outcrop may be verified by the following method: From the point *D* on the outcrop line *A A*, draw a line *D F* on the map at right angles to the line *A A*. Supposing the surface to be level from *D* to *F*, measure off a distance, say 100 yards, from *D* to *E*. As the angle of dip of the seam *A A* was indicated by the clinometer, the depth at which the seam *A A* lies below *E* can be calculated by a similar method. The distance from the probable line of outcrop of *B B* to *E* may be calculated, and also the angle of dip of *B B* being known, the depth at which *B B* underlies *E* may be calculated.

Supposing the angle of dip of each seam is  $40^\circ$ . If the distance from *D* to *E* is 100 yards, or 300 feet, then having the horizontal distance *D E*, as measured on the level surface of the ground, and the angle  $40^\circ$ , by multiplying the distance *D E* by the natural tangent of the angle, the required depth is found.

In this case the distance is 300 feet. The natural tangent of  $40^\circ$  is .8391; therefore,  $.8391 \times 300' = 251.73$  feet deep, from the surface at *E* to seam *A A* vertically below point *E*.

In the same manner, if the distance from the probable line of outcrop of coal *B B* is 150 feet to *E*, then  $.8391 \times 150$  feet = 125.86 feet deep from surface at *E* to seam *B B* vertically below point *E*.

The same results can be obtained by the rule given in Art. 1387, if it is remembered that one angle of a right-angled triangle is always  $90^\circ$ , and the third angle can be found by subtracting the given angle +  $90^\circ$  from  $180^\circ$ .

By putting down another hole at *F* and calculating the depths in the same way, it will be known at what depth to expect all the seams *A A*, *B B*, and *C C* at *F*.

Care must be taken in setting out the line *D E F* at right angles to the line of outcrop, or otherwise the true angle of dip will not be obtained.

**1430.** Fig. 406 shows in plan and section a complicated piece of ground which can be proved only by boring. In this case the seam was opened by a slope at *A*, which ran against the fault *B*, which was then carefully looked for and located on the surface.

Bore holes *C* and *D* were put down and located the seam

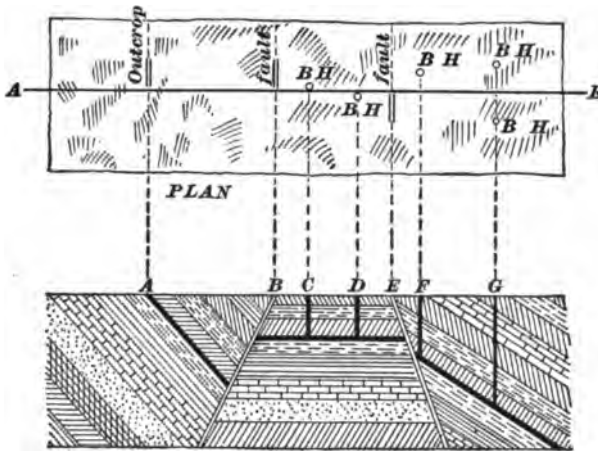

Section through line *AB* on plan.

FIG. 406.

at equal depth. Then the hole *F* was put down, and it found the seam at a greater depth than the two former holes, making additional data necessary. Therefore the two holes *G* were put down, and they, with the hole *F*, furnished the data by which the angle and line of dip was proved. They also made evident the existence of the fault *E*.

**1431.** Fig. 407 shows conditions where some difficulty will be experienced in proving the "lay" of the various seams. If the probable line of the outcrop of *C* is followed, as indicated by the dotted line *Ca* from the west river, no crop will be found in the east river. But on going up the east river, an outcrop corresponding to *C* on the west river will be found. A survey of it indicates the crop traveling in the direction of the dotted line *Cb*. By traveling up the streams the same conditions are again met. Why do these

indicated crop lines not lead to the seam on the other river, is a natural question. There must either be a swelling of the strata between the outcrops or there is a fault of vari-

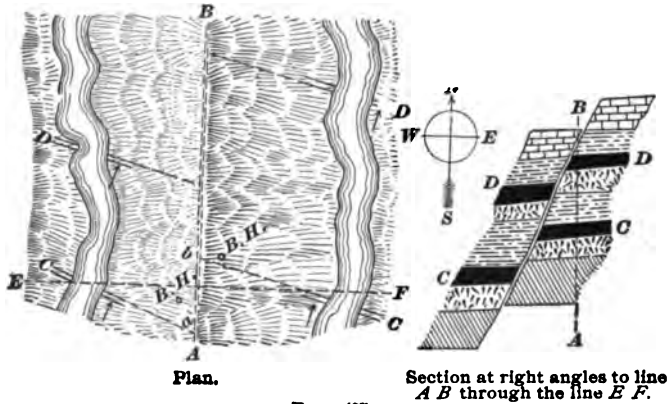

Plan.

Section at right angles to line  
A B through the line E F.

FIG. 407.

able throw between the two rivers. To prove which of the two assumptions is correct, a number of trial shafts or shallow bore holes must be put down, as the rules previously given can not be successfully applied.

**1432. Trial Shafts.**—Good laborers will sometimes sink a shaft ten feet deep without a staging, that is, a platform to throw the dirt on.

When the depth exceeds ten feet, it is necessary to build a staging or cut a step to throw the earth upon (from which it is again shoveled and thrown from the pit), or to erect a windlass for hoisting.

When the depth exceeds fifteen or eighteen feet a windlass becomes necessary. This may be a very primitive affair, but should be strongly built. A hemp rope one inch in diameter and a strong iron-bound wooden bucket holding about 80 or 100 pounds complete the outfit.

The upright upon which the rope shaft rests should be securely braced both at the sides and back.

Some men prefer sinking square shafts, others prefer sinking round holes. If the ground is firm, the shape is a matter of minor consideration. A rectangular hole about

4 feet  $\times$  5 feet gives sufficient working room, and is for some reasons preferable to any other form.

A square shaft is best adapted to sinking in loose treacherous ground, which threatens to cave in and needs heavy timbering. Theoretically a hexagonal or octagonal hole is better under these conditions, but it is difficult to cut the joints and fit the timbering with sufficient accuracy to yield the requisite resistance to side thrust, whereas square timbering is easily fitted, and not so apt to become displaced, and is, moreover, much cheaper.

The timbering is kept in place either by supporting beneath or hanging it from above, being of course in either case wedged in place as tightly as possible by wedges and by a series of boards, waste slabs, or small round pieces driven in behind the timbers.

Round timbers, six or eight inches thick, may be used for the crib work, but square timbers are better, as they can be more easily and accurately fitted.

The distance between the cribbing girths, that is, the distance between each set of framed timbers, will depend entirely upon the character of the ground and depth to which timbering is necessary. It is never advisable to place them more than six feet apart, and generally they should be closer together.

One end, side, corner, or the center of the pit is kept in advance of the average level of the shaft bottom, thus providing a sump for the water, as well as giving a loose end to the material being excavated.

### **1433. Conditions Requiring Special Attention.**

—By referring to Fig. 403 it will be seen that the two bore holes shown at *E* and *F* reach the seams *C* and *D* at the same level, and through lack of any surface indications, it would naturally be supposed that they are the same seam, unless there is a marked difference in the composition of the coal, or in the overlying or underlying strata. To detect these differences requires a close scrutiny of the borings.

In boring there are many geological peculiarities which

sometimes tend to deceive the prospector. For instance, suppose two bore holes are put down at *A* and *B* (Fig. 408), say 3,000 feet apart. The bore hole at *A* proves a seam 3

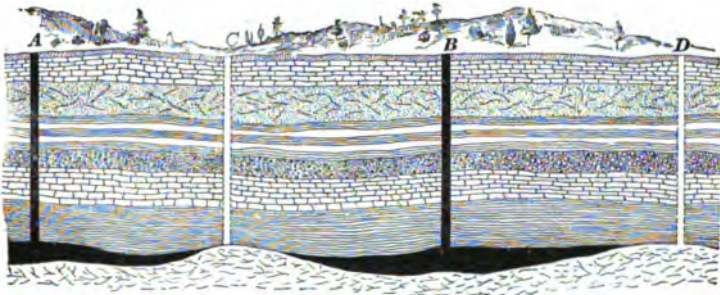

FIG. 408.

feet thick, and at *B* the coal is found at about the same level 6 feet thick. It would be natural to suppose that this seam was one which was gradually thickening as it went from *A* towards *B*, and that it would be found about four feet thick at *C*, or seven to eight feet thick at *D*; whereas, it is only a streak, or there is no trace at all at these points. These pockets of coal are frequent, and very deceptive to the inexperienced.

Again, if bore holes were put down at *C* and *D*, finding no coal but Sub-Carboniferous strata instead, that does not absolutely prove there is no coal, for a hole at *A* or *B* would find coal. These are samples of conditions that are frequently met in some of the American coal fields.

**1434.** The splitting of coal beds is a very common occurrence, and this should always be watched for in boring. It is not sufficient simply to bore down to the bottom of a seam whose existence is to be proved. For instance, in Fig. 409 bore holes have been put down at *A* and *B*. Each of these proves a seam of coal at about the same depth and of the same thickness. If the bore hole *B* had been deepened it would have shown quite different results.

As some coal beds are so much cut up and disturbed by "clay veins," "horses," etc., as to become unworkable at a profit, it is necessary for the prospector to scan the



outcrops for them, and in boring to anticipate them and make all due allowances.

It should be remembered that sandstones are apt to vary

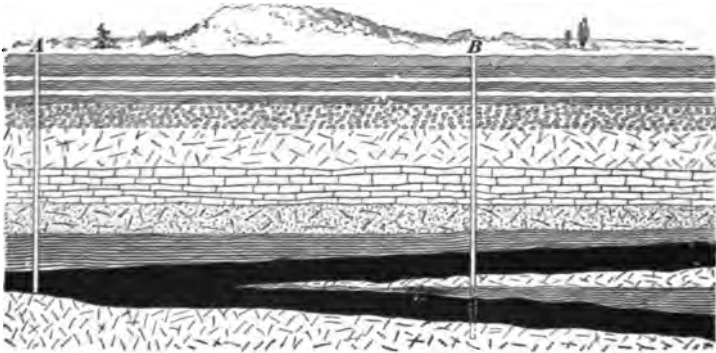

FIG. 400.

in thickness and persistency more than the other varieties of rock in the coal measures; therefore, they do not afford such reliable evidence of the near existence of coal seams as strata of other kinds of rock.

Wherever organic matter is found, whether in the form of fossils or coal, the sandstones and shales are white or gray. All sandstones of the Carboniferous measures, or of other strata, containing coal are gray, while the old red sandstone below the coal and the new red sandstones above the coal, and, in fact, all red sandstones, are very poor in fossils or evidence of organic matter of any kind.

**1435.** Before leaving this subject, one more instance, embracing both conditions, will be given.

The imaginary line about which the beds may be supposed to be bent is called the axis of the anticline or the syncline. This axis may be either horizontal or inclined. If it is horizontal, sections taken in any part will show the same beds. But if it is inclined, different sections will cut different beds. Prof. Jukes, of the British Geological Survey, gives the example shown in Figs. 410, 411, and 412. Fig. 410 is a plan of undulating beds, the axis of the anticlinal and synclinal curves being inclined—in this case

dipping to the north, as shown by the arrows. It is plain

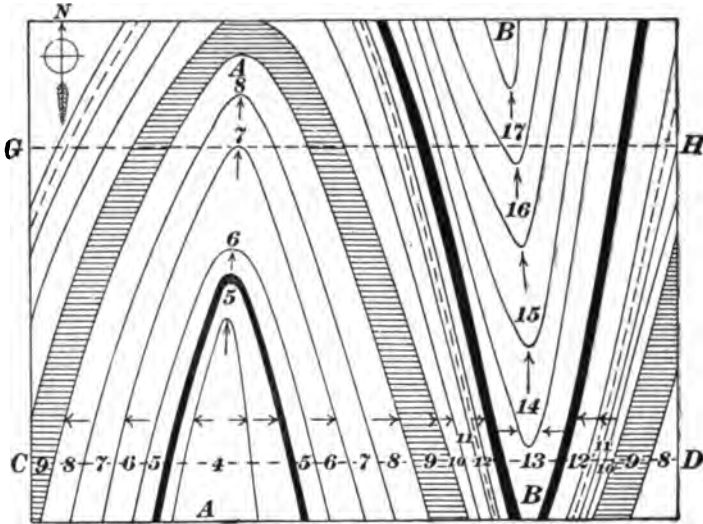

FIG. 410. Plan.

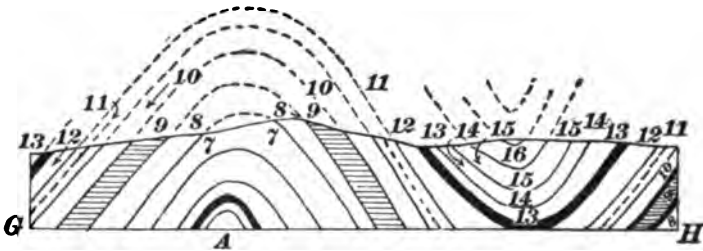

FIG. 411. Section through G H.

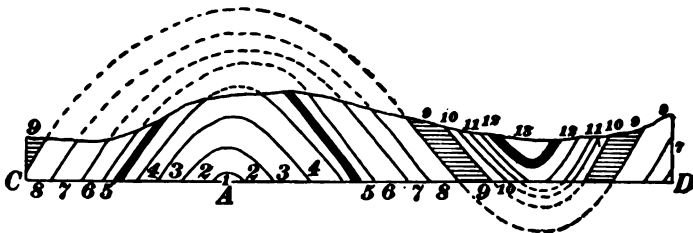

FIG. 412. Section through C D.

that unless the surface of the ground slopes with the axis, other beds must come in, arching over each other in the

case of the anticline, or resting upon each other in the case of a syncline. Thus, bed No. 4 will "nose in" under the new bed No. 5, which, in its turn, will "nose in" under No. 6, and so on. In like manner, in the syncline, bed No. 14 will "nose out" over No. 13, No. 15 over No. 14, and so on. Hence, if a section is taken along the line *CD* in the plan (Fig. 410), such a section will appear as in Fig. 412, in which bed No. 4 forms the crest of the anticline, and bed No. 13 is the highest in the syncline. But if a section be taken along the line *GH*, this section will appear as in Fig. 411, in which bed No. 7 forms the crest of the anticline, and bed No. 16 is the highest in the syncline. It is of the utmost importance to observe carefully the inclination of the antinclinal and synclinal axes.

**1436.** Sir Charles Lyell has probably presented this matter clearer than ever before:

"There are endless variations in the figures described by the basset-edges (outcrops), according to the different inclinations of the beds, and the mode in which they happen to have been denuded.

"One of the simplest rules with which every prospector should be familiar relates to the V-like form of the beds as they crop out in an ordinary valley. First, if the strata be horizontal the V-like form will be also on a level, and the newest strata will appear at the greatest height.

"Second, if the beds be inclined and intersected by a valley sloping in the same direction, and the dip of the bed

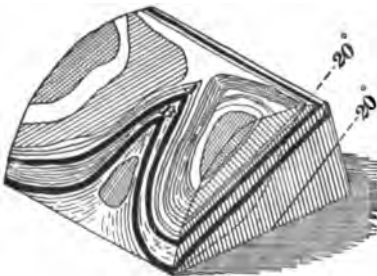

FIG. 413.

be less steep than the slope of the valley, then the V's, as they are often termed by miners, will point upwards (see Fig. 413), those formed by the newer beds appearing in a superior position and extending highest up the valley, as *A* is seen above *B*.

"Third, if the dip of the beds be steeper than the slope

of the valley, then the V's will point downward (see Fig. 414), and those formed of the older beds will now appear uppermost, as *B* appears above *A*.

“Fourth, in every case where the strata dip in a contrary direction to the slope of the valley, whatever be the angle of inclination, the newest beds will appear the highest, as in the first and second cases. This is shown by Fig. 415, which exhibits strata rising at an angle of  $20^\circ$  and crossed by a valley which declines in an opposite direction at  $20^\circ$ .

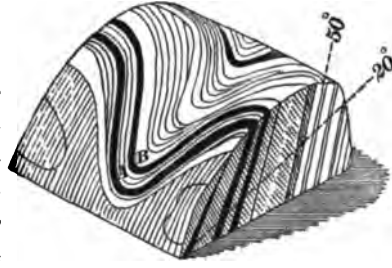

FIG. 414.

“A prospector unacquainted with the rule, who at first explored the valley (Fig. 413), may have sunk a vertical shaft below the coal seam *A*, until he reached the inferior bed *B*. He might then pass to the valley (Fig. 414), and discovering there also the outcrop of two coal seams, might begin his workings in the uppermost in the expectation of com-

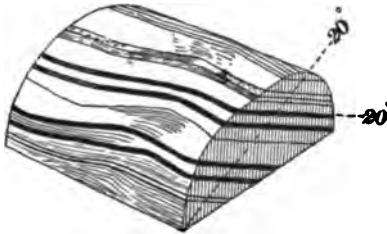

FIG. 415.

ing down to the other bed *A*, which would be observed cropping out lower down the valley. But a glance at the section will demonstrate the futility of such a hope.”

#### DETERMINATION OF QUALITY AND QUANTITY OF COAL.

**1437. Sampling.**—The prospector in selecting a sample for analysis must bear in mind that his prime object should be to secure a sample fairly representing the average quality of the coal to be shipped to the market. He must not select a sample that will represent the coal in the bed, for that condition may be improved upon in

preparing the coal for market. Neither is it advisable to select a fine specimen, or sample, for that will represent a better coal than can be prepared for the market, unless the coal is perfectly free from impurities and has the same constituents throughout its whole composition, which is not to be expected.

Sometimes a bituminous coking coal at the surface is found to graduate into a cannel coal or a block coal when the field has been penetrated some distance; therefore, great attention should be paid to the change presented in the coal as the prospect advances, and the sample taking should be postponed until the true coal of the bed is reached.

If the sample is to be taken from a drift, tunnel, or slope driven in far enough to show the true quality of the coal, a small piece should be taken from every inch of the seam, care being taken that the fragments shall be of equal amount from each part of the bed, so that they will make such a sample as would be obtained by cutting out a block of coal 3 inches to 4 inches square (or more) and as high as the bed is thick.

The parting bands of slate, sulphur (pyrites), etc., should always be included in the sample, unless the bed contains a thick layer of slate or bone that readily breaks loose from the coal and can be cleaned from the coal in mining. In this case the parting may be represented in the sample by such a piece as would be taken if the parting were only a thin layer.

Sometimes different beds of coal of entirely different quality come together or are separated only by a very thin layer or parting, and are suitable for different uses, such as steam making, domestic use, gas making, etc. In such a case a fair sample should be taken of each quality to show the percentage of each constituent, and a sample of the full thickness of all the qualities to show the general percentage of their constituents.

The same attention should be given in each case to bone, sulphur, etc., as mentioned before.

After the sample has been fairly selected, it should be carefully broken into smaller pieces on a clean floor or iron plate, and then thrown up in a conical pile and quartered. Two quarters opposite each other should be thrown out. The remaining quarters should be broken, made still finer, mixed, heaped up in a conical pile and quartered as before, and this process should be repeated, in large samples, until only a small keg full is left from which the analysis should be made.

When the analyses are made the contents of this keg should be again quartered, ground finer, and requartered, until only enough is left to fill a few small vials, each vial containing sufficient for one or two analyses.

When the sample obtained is a small one it should be ground and quartered, each quarter being ground again and requartered until a powder as fine as flour is secured.

Fill four vials with the pulverized coal of the last quarters, that is, one vial from each quarter, resulting from each of the first four quarters. The mean of the analyses of these four parts of the original sample will be a true representation of the constituents of the coal in percentage; or, these four parts may be carefully mixed and quartered until just sufficient for the analysis remains, and such an analysis will also be a true representation of the constituents of the coal in percentage.

**1438. Analyses.**—A proximate analysis of coal determines readily, without any costly appliances or much skill, the proportion of water and ash present in any given specimen of coal, and the proportion which volatile matter bears to the carbon, and this is all that is required to determine the value of coal as a commercial commodity. The mode of conducting such an analysis is as follows:

*Moisture.*—Dry 2 grammes of the coal, finely pulverized, in a weighed platinum crucible (a tarred watch glass or a flat-bottomed iron pan may be used) at 220° to 240° Fahr. for half an hour, cool, and weigh. Dry again for 15 minutes at 220° to 240° Fahr., cool, and weigh again. Repeat this

until the weight begins to increase, indicating incipient oxidation. From the lowest weight thus obtained calculate the percentage of moisture. (The notes further on will show the calculation.)

*Volatile Combustible Matter—Hydro-Carbons.*—Heat the above crucible and contents for three minutes (keeping the crucible closely covered) in the strongest heat of a good Bunsen burner, or other hot flame, then immediately heat for the same length of time over the blast lamp, cool, and weigh. The crucible should be kept covered throughout the operation. The loss is volatile combustible matter with half the sulphur, because sulphur existing as pyrites may be regarded as volatile or combustible. For anthracite, or coals containing no bituminous matter, this operation is unnecessary.

*Fixed Carbon.*—Remove the cover and burn off the remaining carbon over a Bunsen burner, or other hot flame, until nothing remains but the ash. The loss is fixed carbon with the remainder of the sulphur.

*Ash.*—The final weight, less the weight of the crucible, gives the ash.

**1439.** *Sulphur.*—The determination of the quantity of sulphur contained by a specimen of coal presents greater difficulties than that of the moisture, hydro-carbons, or ash, and for correct results requires appliances and processes belonging more particularly to the laboratory. However, it is frequently necessary to *estimate* the quantity of sulphur, and the following method is given:

Fuse one gramme of the finely pulverized coal with a mixture of ten grammes of carbonate of soda, and six or seven grammes of nitrate of potash. Heat gently at first and until fusion is calm, then continue heating for about a quarter of an hour. Dissolve the contents of the crucible in water, add slowly just enough hydrochloric acid until the solution turns blue litmus paper red, and evaporate to dryness to render silica insoluble. Redissolve in dilute hydrochloric acid, filter off the silica, and precipitate the sulphur

in the filtrate by means of choride of barium. Allow the precipitated sulphate of barium to stand undisturbed for several hours. Then filter, wash well on the filter, ignite, and weigh. Multiply the weight in grammes of the sulphate of barium by 0.13734, and the result will give the weight in grammes of the sulphur.

**1440. Notes.**—The following is perhaps the most convenient method of keeping the notes of a coal analysis:

Weight of crucible and coal.....	32.0000 gms.
Weight of crucible.....	30.0000 gms.
Coal taken.....	<u>2.0000 gms.</u>
Weight of crucible + coal.....	32.0000
Weight of crucible + coal, after drying....	<u>31.9920</u>
Loss = water.....	0.0080 = 00.40%
Weight of crucible + coal, dried.....	31.9920
Weight of crucible + coal, heated (closed) ..	<u>31.4480</u>
Loss = volatile combustible + $\frac{1}{2}$ S.....	0.5440 = 27.20%
Weight of crucible + coal, heated (closed) ..	31.4480
Weight of crucible + coal, heated (open) ..	<u>30.1000</u>
Loss = fixed carbon + $\frac{1}{2}$ S.....	1.3480 = 67.40%
Weight of crucible+contents, heated (open).	30.1000
Weight of crucible.....	<u>30.0000</u>
Residue = ash.....	0.1000 = 5.00%
Sulphur.....	1.00%

REPORT.

Moisture.....	0.40%
Volatile combustible (27.20 less 0.5 or $\frac{1}{2}$ S)..	26.70%
Fixed carbon (67.40 less 0.5 or $\frac{1}{2}$ S).....	66.90%
Ash.....	5.00%
Sulphur.....	1.00%
	<u>100.00%</u>

NOTE.—The several percentages are found by dividing each remainder by the weight of the original sample, which in this case was 2 grammes.

For accurate analysis a good balance, of course, is



essential, but for the prospector's purpose a less costly and less delicate balance will suffice.

The prospector should be familiar with the varieties and characteristics of the different coals as given in *Economic Geology of Coal*, and also with the following :

In anthracite volatile matter is usually less than 7%.

In semi-anthracite volatile matter is usually less than 10%.

In semi-bituminous volatile matter is usually less than 18%.

In bituminous volatile matter is usually more than 18%.

A few analyses of anthracite and bituminous coals, lignites, and peats (the moisture excluded) are given with the Tables and Formulas for comparison with the prospector's results.

**1441. Calorific Power of Coal.**—The same difficulty is met in determining the calorific power of coal as in judging of the coking properties. The calorific power, which is the total heat developed by coal on combustion, has a much greater importance than is understood by consumers. One coal may be bought cheaper than another, but if the low-priced coal has less calorific power than the other coal, the purchaser may not be getting the best value for his money. Coals rich in oxygen never have such high calorific power as those containing a smaller amount. The larger the proportion of volatile matter present, the lower is the calorific power of the coal. That the calorific power varies as the proportion of fixed carbon after distillation has been shown by many eminent chemists.

Mix 1 gramme of the finely powdered coal carefully with not less than 20 or more than 40 times its weight of finely sifted litharge containing no metallic particles. Place the mixture in a small crucible and cover it with 30 times its weight of litharge. That the mixture may not boil over, the crucible should be only half full. Cover the crucible, and heat gradually in a muffle or wind furnace to red heat. If the heat is raised too rapidly, combustible gases escape, or the mass may boil over. In using a wind furnace, the

crucible should be placed on a firebrick resting on the grate bars supporting the glowing coals. Shake coals around it until only the top of the crucible protrudes.

When the mass, which at first swells up, is fused, cover the crucible entirely with coals, and increase the heat for ten minutes to collect the lead in a button and then take it out. The whole operation lasts from 45 to 60 minutes. Break up the crucible, clean the button from adhering lead oxide by means of a brush, and weigh. To obtain a reliable average, from two to four tests must be made. As unity we refer to carbon, which reduces 34 times its weight of lead. The calorific power of carbon is 8,086 French heat-units\* ; every part of lead produced in the button =  $\frac{8,086}{34} =$

238 heat units. This result multiplied by the weight of the lead button, in grammes, gives the heat units contained in the coal. This result is not absolutely correct, but at most is only one-tenth too low, and is closer the higher the percentage of carbon in the coal.

It must be borne in mind that the result is the amount of heat, not the intensity, as that depends on the rate of combustion.

**1442. Coking Coal.**—As was stated before, the only positive manner of testing a coal for coking properties is a practical test ; but among some coals of the eastern side of the Appalachian field there is a ratio between the hydrocarbons and fixed carbon, which enables a fair conclusion to be drawn as to their coking qualities. The coals of the western side contain too much bituminous matter to make very good coke. For this reason, but a small amount of coke is made in the pitchy coal fields of Ohio, Indiana, and Illinois.

The Colorado, Wyoming, Montana, New Mexico, and other Western, or Northwestern and Southwestern, coals belong to the Trio-Jurassic and Laramie-Cretaceous

---

\* A French unit of heat is equal to 3.96832 British thermal units, or, in other words, one French unit of heat will raise the temperature of 1 kilogramme of water 1.8° Fahr.

measures, and are independent of the ratio just mentioned. Some of these coals coke readily in the common bee-hive oven, while on the other hand a large portion of them, very high in hydrogenous matter, can not be coked.

Sometimes coals that will not coke in any oven will yield a splendid coke if a proper proportion of pitch is mixed with them.

It is becoming more evident daily that the property of coking is dependent upon the relation and volume of the elements composing the volatile combustible matter.

The prospector may well bear in mind that the moisture, fixed carbon, ash, and sulphur may differ widely without seriously affecting the coking properties. This is most conspicuously shown in the very large difference existing in the volume of carbon and ash in the Connellsville and the Pocahontas coals. Connellsville coal contains 59.79% of fixed carbon, while Pocahontas contains 72.70% of fixed carbon. The ash exerts no influence on the fusing of these coals in coking. Neither does sulphur nor phosphorus; both are simply undesirable in metallurgical coke.

As a unit of carbon affords 8,086 calories of heat, while a unit of hydrogen affords 34,462, coals low in volatile combustible matter must surrender in the ordinary oven an increased volume of carbon to compensate for the deficiency in the reduction of the greater heat giving hydrogen. In other words, heat required for coking, not supplied by the volatile matters, must come from the fixed carbon. This is seen in the fact that Pocahontas coal loses 20% of carbon in coking, while Connellsville coal loses only 8% of carbon in coking. The table of Coking and Non-Coking Coals in the Tables and Formulas may, in connection with the table of Analyses of Coal, be of advantage to the prospector.

**1443. Specific Gravity.**—To find the specific gravity of any body heavier than water, take a small cuboidal piece of the material suspended by a hair, weigh it in air, then in water; find the difference in weight. This difference is what the body loses in weight in water, and is the

weight of a bulk of water equal to the bulk of the body.  
Diff. of weights: Weight in air :: 1 :  $x$ , or

$$\frac{\text{Weight in air}}{\text{Difference}} = \text{specific gravity of body.}$$

**EXAMPLE.**—A piece of coal weighs 480 grains in the air and weighs 398 grains less in water. What is the specific gravity?

**SOLUTION.**— $\frac{480 \text{ grains}}{398 \text{ grains}} = 1.206$  specific gravity. Ans.

**1444. Weight of Coal.**—A cubic foot of water weighs 62.355 lb., and this 62.355 lb., multiplied by the specific gravity of coal, gives its weight per cubic foot. Thus,  $62.355 \times 1.206 = 75.2$  lb. per cu. foot, when the specific gravity of coal is 1.206.

**1445. Tonnage per Acre.**—The number of tons of coal in any tract of land may be calculated by finding the number of cubic feet and multiplying it by the weight of a cubic foot in lb., and dividing the product by 2,240 for long tons, and 2,000 for short tons.

**EXAMPLE.**—How many tons are in an acre if the coal is 20 inches thick and the specific gravity is 1.206?

**SOLUTION.**—One acre = 43,560 sq. ft.

20' thick =  $1\frac{2}{3}$  or  $1\frac{1}{3}$  feet.

$43,560 \times 1\frac{1}{3} = 72,600$  cu. ft.

As was stated above, coal having a specific gravity of 1.206 weighs 75.2 lb. per cu. ft.; therefore,  $72,600 \times 75.2 \text{ lb.} = 5,459,520 \text{ lb.}$ , and  $\frac{5,459,520 \text{ lb.}}{2,000 \text{ lb.}} = 2,729.8$  short tons per acre. Ans.

A very convenient manner of making such a calculation is that used by Scotch mining engineers when checking the reported tonnage of the operator to the proprietor of the estate.

The specific gravity is found, the decimal point is removed, and the figure 1 is annexed; this gives the tonnage per inch per acre with due allowance for faults, wants, etc.

**EXAMPLE.**—How many tons of coal are in an acre, the coal being 3 feet thick and specific gravity 1.3?

**SOLUTION.**—Specific gravity being 1.3, the number of tons per inch per acre will be 131.

$131 \text{ tons} \times 3 \text{ (feet)} \times 12 \text{ (inches)} = 4,716 \text{ tons per acre.}$  Ans.

### LOCATION OF OPENINGS.

**1446. Prospecting Party.**—This should never consist of less than the leader and two laborers. It is often necessary and nearly always advantageous to have from 4 to 10 laborers in the party.

**1447. Tools.**—If the prospecting is to be done at a location remote from a town, in addition to the camping, surveying, and chemical outfit, there should be a pickax and shovel for each laborer, two axes, and one or two sets of drilling tools—jumper, hammer, scraper, needle, etc., and explosives. Also a wheelbarrow or two, hatchet, adz, nails, etc.

The prospector himself must have the following with him while in the field: 1. A pocket compass, with which to

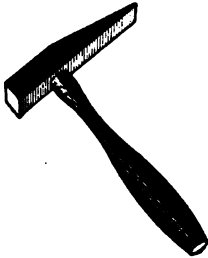

FIG. 416.

ascertain the direction of any line of outcrop, dip, fault, etc. 2. A clinometer for the purpose of noting the angle of inclination of exposed strata. 3. A small hammer with a chisel-shaped head at one end, similar to Fig. 416 (this chisel-edge enables him to conveniently split finely laminated shales or slates). 4. A small bottle containing a weak solution of hydrochloric acid, for the purpose of testing carbonates (on applying this acid to limestone it effervesces). 5. A note book and pencil.

**1448. Location of Permanent Openings.**—The place or spot at which the mine openings should be located will be largely indicated by the data laid down on the complete map. This will show the extent of the property, whether the coal crops out within the boundary lines or not, the roads, railroads, canals, rivers, and the general configuration of the surface, important faults, etc.

In mountainous regions where the coal lies in conical hills, it is evident that the railway must follow mostly the direction of the valley, and in such cases where the coal

crops out within the limits of the property and the seam is flat, the opening is best made by a drift or day level (Fig. 417) at such a point as can be readily reached by a spur



FIG. 417.

from the railroad. If the coal has any considerable dip and outcrops on the property where the railroad can reach it, it should be opened by a slope driven in the coal. When the pitch is very great, say  $40^\circ$  or over, and the area of coal above the point at which a level tunnel or stone drift will strike the coal will guarantee the outlay of capital, the "stone drift" driven "across the measures," or strata having a slight rise inwards, may be adopted. These stone drifts under such conditions are very rarely undertaken on account of the great expense. Where the measures are flat

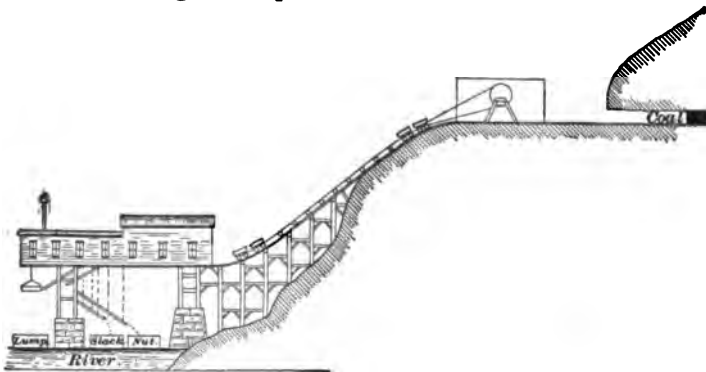

FIG. 418.

the railroad is located at a point suitable for tipple arrangements below the lowest outcrop, if possible. Sometimes

the coal is at such a height above the railroad or waterway that a self-acting incline must be used to lower the coal to the tipple (Fig. 418). At many mines a number of seams are worked simultaneously, the coal being lowered to the tipple by self-acting inclines. There are many cases where the coal does not crop out on the property, or the outcrop can not be reached by the railway. If the coal has no outcrop on the property, a stone slope or a shaft must be sunk. At vertical depths not exceeding 200 feet, "stone slopes" (pitching about  $14^{\circ}$ ) are in great favor with some mining engineers. If the coal crops out at a point below the railroad, as it often does, an engine plane is built which carries

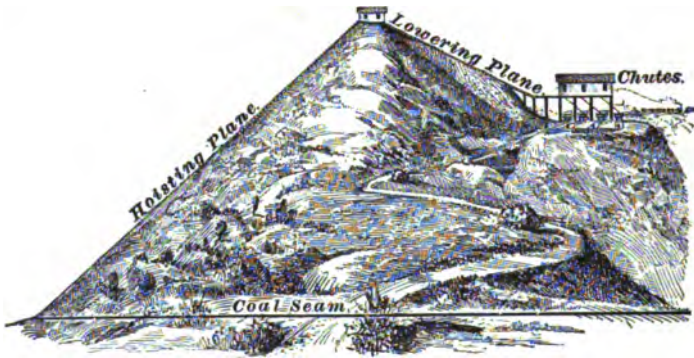

FIG. 419.

the coal to the summit, and in many cases the coal is again lowered by self-acting inclines to the tipple, which is in a valley at an elevation less than the high ridge over which the coal is hauled, but high above the level of the coal seam (Fig. 419).

**1419.** In a district where the coal measures are flat and there is no outcrop, excepting where rivers have cut a channel deep enough to divide the coal seam, an incline is run down a dry channel to the outcrop up which incline the coal is hauled from a great number of drifts (producing sometimes over 2,000 tons per day), whose length may be several miles, if mechanical haulage is employed, to the railroad above. But it often happens that in spite of every

precaution in some seams the main hauling roads can be maintained only to a limited extent, and to reach the coal beyond this limit no other course is open but to sink shafts close enough together to each other so that the limit of the entries or gangways from each shaft or drift will meet, ensuring, as nearly as possible, the extraction of all the coal.

**1450.** When the dip of the valley in which the coal crops out is equal to or greater than the dip of the coal and in the same direction, as a matter of course, if the railway or even a tramway can be readily built to the opening it should be made at the lowest point of the area it is to supply the outlet for, to ensure a favorable mule haulage and good self-drainage. In some districts the coal is so undulating and irregular that drainage and haulage have no weight in deciding upon the position of the location. The object

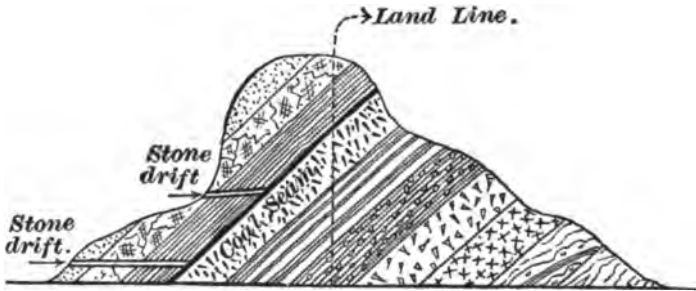

FIG. 420.

here to be considered is a suitable site for hauling and pumping machinery. When the seam has a heavy pitch inwards and the hills are high, a "day drift" or level may be located in a ravine or gulch eroded across the strike (see Fig. 420), and the coal can be reached by a short "tunnel" or "stone drift," from which the coal lying above it can be mined. If the length above the drift is less than 200 feet to 300 feet, a slope had better be started at once.

**1451.** When the seam has considerable dip and is brought close to the surface by an anticlinal axis, a "rock slope" dipping at the same angle as the seam may be started



from the surface (*A*, Fig. 396), and when the coal is reached it may be carried in the coal to any practical length. Where the coal crops out it is customary to drive an airway parallel with the slope, leaving the pillar required by law between. But where the coal turns on the axis before reaching the surface and a "rock slope" is driven, as just described, the parallel slope is driven only in the coal and a shaft sunk at the axis to the coal for an airway.

When the coal lies more than 200 feet below the surface (where the rocks have been metamorphosed, much less than 200'), in rocks of moderate texture, no other method of reaching the coal except shaft sinking is worthy of consideration. When the top rock is such that long roads will stand without an undue amount of care and expense, the openings should be made with a view to concentrating the work of a large output in one opening. A number of shafts create very great expense, not only in sinking, but for engines, pumps, tipples, spur tracks from railroad, etc. Further, the number of day hands does not vary directly as the output, that is, a larger number of day hands as a rule will be required to handle 400 tons per day from each of two pits than will be required to handle 800 tons per day from one pit. The opening must also be located, if the seam is inclined, so that most of the field will be to the rise of the pit bottom, so that haulage and drainage may be facilitated. In other words, other things being equal, the site which gives the largest amount of field to be worked to the rise is preferable. Surface conditions sometimes outweigh underground considerations.

**1452.** In a new field it is never desirable to make the first shaft the permanent one, or the most important one. The permanent shaft may be better located later on, when more detailed knowledge of the district has been obtained.

When the seam underlies a great tract to such an extent that it can not be reached by a drift from the outcrop, or when there is no outcrop, and the coal can not be hauled through one or two shafts, the surface configuration permitting, shafts should be located systematically with regard

both to the area of the field and the area for which each shaft will be the outlet. In order to accomplish this it will be best to wait until the extent to which the workings of the first shaft can be profitably extended, mechanical haulage considered, is determined. The demand for a very large tonnage early in the history of the field sometimes requires more than one shaft at once, in which case the best location must be selected that is indicated by the information on the map.

Quicksands may modify the arrangements, as may also great quantities of water, but never to any great extent in these days of improved facilities for sinking.

Slopes, up to the present time, have been and still are greatly preferred to shaft openings at all points in the anthracite regions of Pennsylvania, where the coal is accessible along its outcrop and where the dip is more than  $15^{\circ}$  or  $20^{\circ}$ .

In the bituminous region of Pennsylvania and many of the Western States shafts of moderate depth are common.

As many outcropping seams have a slight inward dip, to ensure a long level haulage road and good water drainage, the opening is commenced several feet below the terrace, and driven level, or on a very slight up grade, until the normal dip is reached. It sometimes happens that the inward dip is so strong that it is advisable to open by a shaft sunk in the center of the basin, provided the depth is not too great and the amount of water small. When the inward dip to the center of the basin does not exceed about 24' or 26', drainage may be accomplished through a drift, by siphon, the pipes being of the diameter required to remove the water.



# SHAFTS, SLOPES, AND DRIFTS.

## INTRODUCTORY.

**1453.** The method of opening out a coal field will depend entirely upon its physical and geological characteristics and upon its position with regard to railroads, rivers, and canals. When a seam of coal lies comparatively flat and is covered by a shallow depth of strata, it is "stripped," and the coal is obtained in much the same manner as building stone is taken from the quarry.

Such easily accessible coal is soon worked out, necessitating other methods of reaching deep-seated seams. Where the seam lies at a considerable depth from the surface, and more especially where it lies flat or nearly so, it is usual and advisable to sink a shaft to win the mineral. If

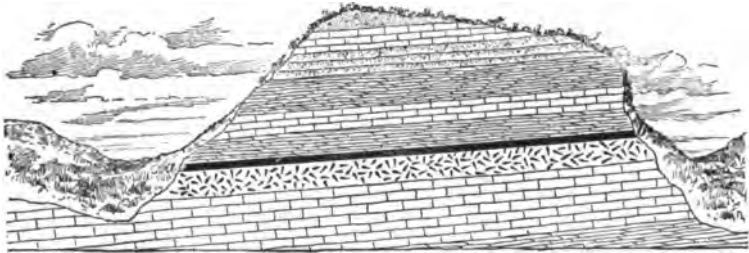

FIG. 421.

the coal lies above water level and nearly flat, as in some parts of the bituminous districts of Pennsylvania, it is most convenient to open it out by means of a "water-level drift." For instance, in the case of a seam of coal lying in a mountain, as shown in section in Fig. 421, the most convenient place to enter the seam would be at *a*, which is the lowest part of the seam, because the water would naturally drain that way and no expense would be incurred for pumping,

the loaded cars would have the advantage of the down grade, and there would be no need to sink a shaft to win the coal.

**1454.** In the case of a seam of coal lying at a considerable dip, and having its outcrop on the side of a hill, as at *a* in Fig. 422, the seam can be opened out in three different ways: 1. A slope can be driven in the seam from *a* to *b*, and the coal drawn and water pumped up the slope. This sys-

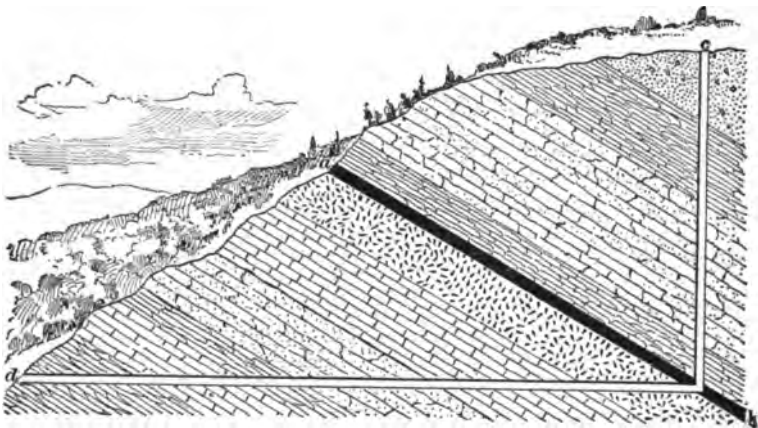

FIG. 422.

tem would have the advantage of enabling the coal field to be more rapidly opened out by means of levels, gangways, or benches turned off at intervals to the right and left of the slope as it is being driven down towards *b*. 2. The coal can be won by a shaft sunk to *b* from the surface at *c*. 3. A tunnel can be driven to *b* from a point *d* on the hillside. This tunnel will have the advantage of a dip towards *d* whereby the entire coal field can be drained by gravitation without any expense for pumping machinery. The haulage can also be done cheaply for the same reason. The decision as to whether the shaft *c b* or the tunnel *d b* will be preferable depends on at least two conditions. If the seam lies somewhat flat, a shaft will be preferable, because a shallow shaft will reach the greater area of coal; but if the seam is more than  $45^\circ$  from the horizontal, then a tunnel will be preferable. ✓

The cost per yard for tunnel driving is very much less than the cost per yard for sinking a shaft, but in the majority of coal fields the seams have a moderate dip, and a tunnel in most cases to win a large area of coal will be very long. The great distance the coal must be hauled, the first cost and maintenance of roads, of long haulage ropes, and the wages and material necessary to maintain this long tunnel will more than cover the cost and maintenance of a shallow shaft to win the same area of coal. The main consideration, however, will be whether a shaft from the top of the hill or a tunnel on the hillside will provide the most convenient point of delivery for the coal.

---

## SHAFTS.

---

### LOCATION OF SHAFTS.

**1455.** Having decided that it is best to open up a coal field by a shaft, the next thing to be done is to determine its location. This must be done with extreme care, for the degree to which the important problems of haulage and drainage may be simplified and the entire operation made a commercial success will depend largely upon where the shaft is situated.

Perhaps there is no other point in the development of coal lands where more errors have been made than in selecting sites for shafts at new collieries. Every fact obtained by thoroughly prospecting the field and investigating the means of transportation should have special attention in fixing the location of the shaft.

**1456.** The shaft should be located to suit:

1. Underground conditions.
2. Surface conditions.

As all the coal mined in the property must be brought to the foot of the hoisting shaft, care must be taken to have the shaft so located that the mine cars can be conveyed to it with the least possible expenditure of labor. This advantage can be secured by sinking the shaft in the basin or

lowest point of the coal field, so that the loaded cars will have a down grade from all sides to the shaft bottom. This is also the most convenient place to erect the pumping plant, as the entire field can be drained from this one point. It must also be remembered, however, that, owing to the enormous expense in sinking shafts, the fewer shafts that must be sunk the better, and the shaft should be so located as to command the greatest area of coal. For this purpose, and more especially with a flat seam, the best position for the shaft is in the middle of the coal field, so that gangways or main entries can be opened out on all sides of the shaft.

In considering the surface conditions affecting the position of the shaft, attention must be paid to the railroad, river, or canal connections. For instance, the railroad may pass through that end of the property where the coal is nearest the surface; and it is then a matter of calculation of cost whether the shaft shall be sunk at the dip end of the field and a branch railroad run across the property, or whether it shall be sunk beside the railroad to save siding expenses. The latter requires more underground haulage to deliver the coal to the foot of the shaft.

The configuration of the surface, the existence of hills, towns, and obstacles of all sorts will influence the engineer in fixing the position of the shaft.

Another condition sometimes requires consideration, namely, the existence of large deposits of surface soil or running sand or gravel. If the shaft can be sunk so as to avoid these, it should be done, as the cost of sinking through a bed of running sand is sometimes enormous. The existence of faults often influences the selection of the site.

### FORMS OF SHAFTS.

#### RELATIVE ADVANTAGES OF DIFFERENT FORMS.

**1457.** There are various forms in which shafts are sunk—circular, square, oblong or rectangular, elliptical or oval, and polygonal.

Generally speaking, the circular shaft is the most secure and the rectangular form least so, and for equal areas the

former requires less "wall cutting" and timber than the latter.

But, while a saving of labor and of materials is thus secured, it does not follow that a manager in America should throw aside the usual rectangular form in favor of the circular one. Aside from the fact that the rectangular shaft is more common, and the workmen are more familiar with it, a circular shaft requires greater skill in timbering or walling, and the timbering or walling itself is of a more expensive kind. The divisions of a rectangular shaft are readily put in, and there is no waste of area as in most circular shafts. In cases presenting few difficulties and in view of the men being more familiar with the rectangular form of shaft, it is more economical, and really better, except where deep sand beds and very large feeders of water are met with. In the latter case, a circular shaft with its greater strength and facility for tubbing is better.

**1458.** The size of any shaft depends upon the use to which it is to be put. In any case, a very "tight fitting" shaft is extremely troublesome, and the increased first cost to secure a little more room is certainly repaid by a greater facility for getting work done, and is particularly advantageous for pumping and ventilation purposes.

Several of the coal-mining States have laws preventing single openings, but there are practically no restrictions as to the purposes for which shafts may be used. Hence, one shaft may be used for hoisting, ventilating, and pumping, or it may be used for hoisting and pumping, and the second one may be used for ventilating and as an escape for the workmen.

---

#### RECTANGULAR SHAFTS.

**1459.** No fixed rule can be given for calculating the size of a rectangular or any other form of shaft. The size is governed by the conditions already mentioned; also by the average hoisting speed, the depth of the shaft, and the thickness of the coal seam, all of which in a manner determine the size of the mine car.



The speed of hoisting the output may vary from 24,000 feet per hour to 40,000 feet, or more, per hour, including the time taken up in charging and discharging at top and bottom.

By deciding upon the required tonnage, the probable depth of the shaft to reach the seam, and the desired output speed, the following rule may be used to find the length of the winding compartments:

Let  $S$  = output speed;  
 $D$  = depth of shaft;  
 $T$  = tonnage expressed in pounds;  
 $N$  = number of working hours;  
 $W$  = weight of a cubic foot of broken coal;  
 $B$  = average inside width of car;  
 $d$  = inside depth of car;  
 $L$  = length of compartment;  
 $f$  = clearance in shaft at ends of cage = 1 foot.

$$\text{Then, } L = \frac{TD}{SNWBd} + f, \quad (85.)$$

that is, the length of the compartment equals the tonnage in pounds times the depth of the shaft divided by the continued product of the output speed in feet per hour, the number of working hours, the weight of the coal per cubic foot, the width of the car, and the depth of the car plus the clearance.

**EXAMPLE.**—Tonnage, 960; number of working hours, 10; depth of shaft, 500 feet; weight of a cubic foot of broken bituminous coal, 50 lb.; output speed, 30,000 feet per hour; average inside width of car, 4 feet; inside depth of car, 3 feet. What is the length of the compartment?

**SOLUTION.**—

$$L = \frac{960 \times 2,000 \times 500}{30,000 \times 10 \times 50 \times 4 \times 3} + 1 = 6 \text{ feet 4 inches in the clear. } \text{Ans.}$$

**1460.** The width of the compartment is yet to be determined. The average width of the car may be 4 feet, but it may be flared to 5 feet at the top, so that the cage will have to be 5 feet plus the clearance on each side of the car—say 3 inches on each side—making it 5 feet 6 inches.

Add to this the width of the angle iron and shoe used in constructing the cage—say 6 inches on each side—making 5 feet 6 inches + 1 foot = 6 feet 6 inches. The conductors, or guides, if of wood, may be from 4 to 6 inches thick—in this case say 4 inches each, and there are two of them—making 6 feet 6 inches + 8 inches = 7 feet 2 inches as the width of the compartment in the clear. In calculating the total length of the shaft, if there are two hoisting compartments and a pumpway, twice the width of the hoisting compartment in the clear plus the width of the two buntons plus the width of the pumping compartment in the clear, equals the total length of the shaft in the clear.

Thus,

$$\left( \begin{array}{c} \text{compartments} \\ 7' 2'' \times 2 \end{array} \right) + \left( \begin{array}{c} \text{two buntons} \\ 1' 4'' \end{array} \right) + \left( \begin{array}{c} \text{pumpway} \\ 6' 0'' \end{array} \right) = 21' 8''.$$

The shaft will, therefore, be 21 feet 8 inches by 6 feet 4 inches in the clear.

This calculation may be modified in various ways. For instance, the tonnage may be nearly doubled under exactly the existing conditions if a double-deck cage is used; or, with the same speed and length of cage, the tonnage be doubled by lengthening the shaft so that two cars can stand side by side on each cage; or the length of the cage may be such that two cars can stand tandem; or these various conditions may be combined on a single-deck cage, and four times the original tonnage hoisted at the same speed. The tonnage may be increased, without enlarging the cage, by increasing the output speed. These statements do not take into consideration the power of the engine, which will have to be strong enough to start the load and hoist it at a sufficient speed.

**1461.** When the size of the shaft has been determined, the next thing in order is to consider the position of the sides of the shaft in relation to the dip of the seam. The long side of the shaft should be as nearly as possible parallel with the line of the dip. When the ends of a cage are in line with the strike of the seam, the charging of the cages

below ground can be most economically accomplished. This arrangement may not suit the railroad on the surface, but it is better to make the shaft bottom right and place the chutes to suit the railroad.

**1462.** It is necessary to consider beforehand the probable depth to be sunk, and to arrange the location of the engines and machinery which are to be permanently used for winding. The manager should provide a proper supply of tools, such as picks, drills, hammers, wedges, shovels, barrels, etc., and he should anticipate the supply of materials that will be required in the prosecution of the work. The work of sinking should be done by experienced men.

If the permanent engine is not ready for work, sinking may be commenced without it, and the material may be hoisted out of the shaft by a portable engine or horse gin. The pit may be sunk to the depth of sixty feet by the aid of a windlass.

Before commencing to sink, it is necessary to set stakes marking the location and position of the shaft. The stakes should be set on line with the sides of the shaft and beyond the limit of excavation, so that they will

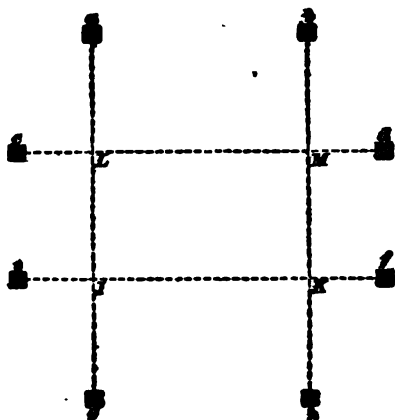

FIG. 423.

not be disturbed by the workmen.

**1463.** The work of sinking is commenced by setting eight stakes *a, b, c, d, e, f, g, h*, Fig. 423, and stretching lines from them as shown. The rectangle *IKLM* marks the outline of the shaft, and must be of such dimensions as to include the outer side of the shaft timbering or walling, as the case may be. It is generally advisable to place a similar set of stakes on the same lines and back still farther

from the shaft. In case anything happens to the inner stakes the outer ones can be used to reset them. The outer stakes should be driven below the surface and their approximate location marked with a stake or stone so they can easily be found. Sometimes surface conditions exist which make it desirable to wall the upper part of the shaft with stone. In such a case the outside cribbing consists of timbers, shown at *a, a*, Fig. 424, and lining plant *b, b*. The timbers *a, a* may be

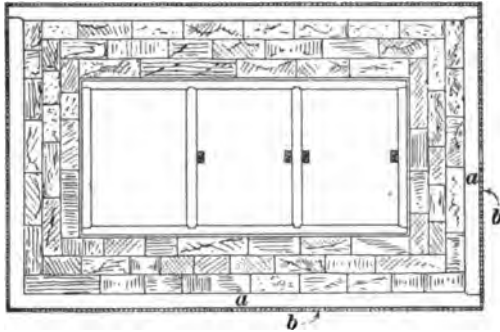

FIG. 424.

12'  $\times$  12'. Each set is placed from one foot to four feet, or more, apart, according to the looseness of the ground sunk through, and held in position by punch blocks *B*, Fig. 425.

**1464.** The sinking should be carried far enough into the stratum, or "hard pan," to ensure a solid foundation for the stone wall. If there is much water, the outside timbering should be removed as the wall is built up, and its place filled with clay, well rammed, to keep back the water. This part of the shaft is then completed, the buntions being put in as the walling is carried upwards. If it is desirable to carry the regular timbering clear to the surface, instead of building the buntions into the walling, the walling must set back far enough for the regular timbering to be put in.

**1465.** Figs. 424 and 425 show the walling and timbering of a rectangular shaft. It is necessary to timber only where the material sunk through will not stand, or where it is necessary to dam back feeders of water.

A set of timbers for a shaft of three compartments usually consists of :

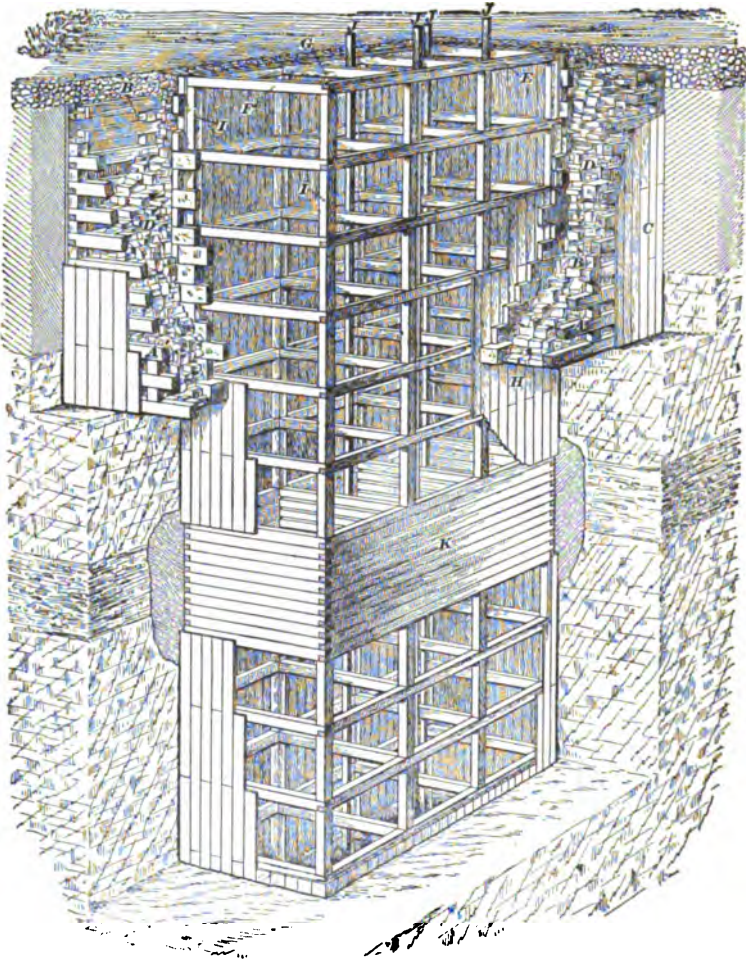

FIG. 425.

1. 2 side pieces,  $10' \times 10' \times -$  feet.
2. 2 end-pieces,  $10' \times 10' \times -$  feet.
3. 2 buntons,  $10' \times 10' \times -$  feet.
4. Sufficient 2 or 3 inch plank to go around the shaft for

lining between the timbers. (See *H*, Fig. 425.) These timbers may be made of pine, or any other durable wood that can most readily be secured. They are kept apart by punch blocks *I*, Fig. 425.

**1466.** When strata of a wet nature are encountered, it is necessary to put in a cofferdam built of masonry or of timber that is placed close together, putting in a tar cloth joint, and bolting the timbers together, or, better still, by mortising one set into the other, so as to form a thoroughly water-tight joint. Such a dam is shown at *K*, Fig. 425.

After the masonry has been built up a foot or two, or one or two sets of timber have been put in, the space between the back of the walling, or timbering, and the strata is filled in with good loamy soil or clay, which should be free from pebbles and should be carefully rammed. Then two more sets are put in and the space filled and rammed in the same manner, and so on till the water-leaking strata are completely closed in and no water appears.

A perspective view of the shaft lining, masonry walling, and cofferdam is given in Fig. 425. In this view, *A* shows the temporary side and end timbers, *B* the punch blocks, and *C* the outer lining put in to go through the soft ground. The masonry is shown at *D*.

The permanent timbers are shown as follows: *E*, side timbers; *F*, end timbers; *G*, buntons; *H*, lining; *I*, punch blocks; *J, J, J, J*, guide rods; *K*, cofferdam.

**1467.** When a shaft reaches hard rock no timbering is needed excepting the guides, or conductors, and buntons for carrying water pipes and guide rods. These buntons are set in the solid rock and wedged tightly in vertical lines, so that the conductors when bolted to them will be plumb. Even when there are no other timbers in a shaft of three compartments, there must be at least four buntons on the same level every six or eight feet for carrying the conductors. When pipes are put in, five or more buntons will be required.

**1468.** If, after the shaft has penetrated the hard strata for some distance, a slight feeder of water is met which

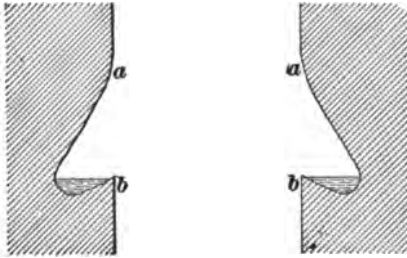

FIG. 426.

can not very well be dammed back, or the water-bearing stratum is very thick and the water only percolates through it into the shaft, the cost of a cofferdam prohibits its use. A "water ring" is then made by widening the shaft at *a*, Fig. 426, and again contracting it at *b*.

The water may be conducted from this "water ring" in pipes to a sump at the shaft bottom.

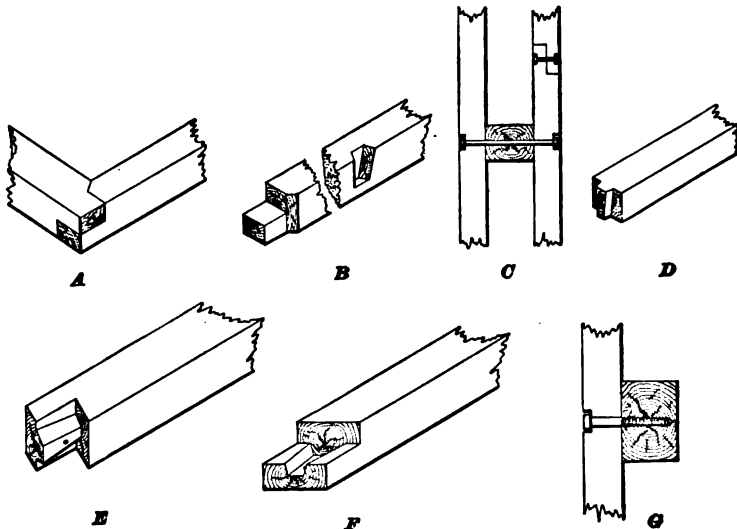

FIG. 427.

**1469.** Fig. 427 illustrates all the joints used in fitting the shaft timbers together.

*A* shows the joint of end and side timbers.

*B* shows the side timber joint and also the dovetailed mortise to receive the dovetailed tenon of buntion *D*.

*D* shows the dovetailed tenon to fit in dovetailed mortise shown in *B*.

*E* and *F* show the method of jointing the guides, or conductors.

*C* shows the manner of bolting *E* and *F* together, and also shows how guides, or conductors, are bolted to the buntions.

*G* shows the guide fastened to the side with a large screw, countersunk, as it is impossible to get behind the timbers when putting in the guides to screw up a nut on a bolt.

There are many other forms of joints, but those given are the best known, and should be used.

**1470.** A plan of the shaft mouth showing carriage

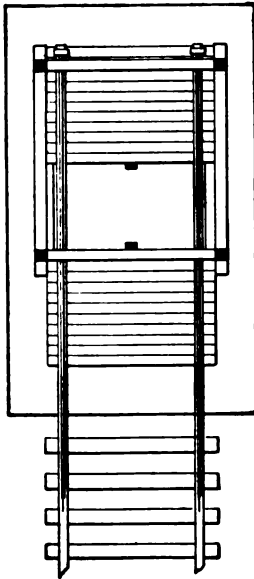

FIG. 428.

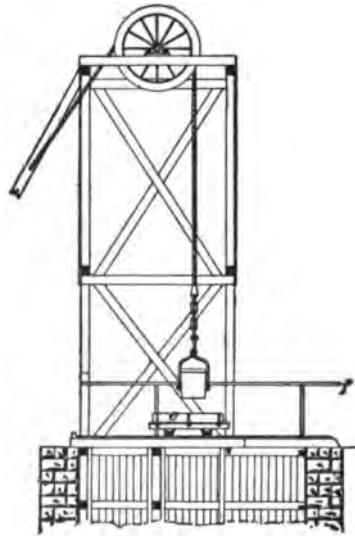

FIG. 429.

track and derrick is given in Fig. 428. In Fig. 429 the



temporary hoisting arrangements for sinking are shown at the opposite end of the shaft from the pumpway. This is to allow the permanent winding machinery at the side of the shaft and the permanent pumping arrangement at the pump end to be erected while the sinking is progressing, if they have not been erected before beginning to sink. The temporary head-frame, or derrick, is so placed that all the hoisting takes place in the middle compartment, in order to equalize the distance the sinkers must move the excavated material to get it into the bucket, bowk, kettle, or kibble, *C*, Fig. 430.

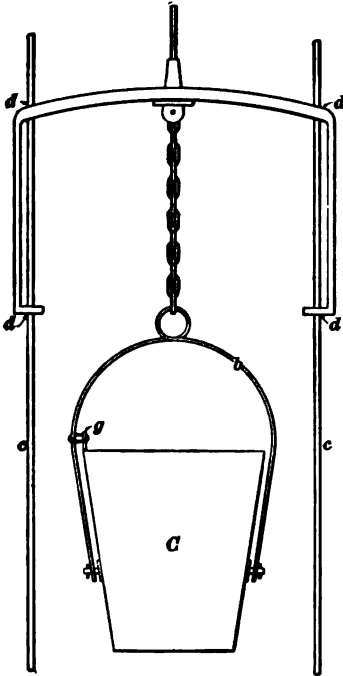

FIG. 430.

1471. The two ends of the shaft are covered with strong planking at the shaft mouth. (See Fig. 428.) At one side of the shaft there should be an opening under the platform to assist ventilation. If this is not practicable, a board stack can be erected over the end of the shaft farthest from the dump. A large car *e*, Fig. 429, running on rails, is placed at the top of the shaft so that it can be run across the part of the shaft mouth which is open, and thus entirely close the top of the shaft, so that when the bucket is being emptied there will be little danger of any pieces, no matter how small, falling on the sinkers below. The excavated material

is filled into a bucket and hoisted to the surface. When the bucket reaches the surface, the topman, headman, or banksman catches the guard-rail *f*, and, standing in the car, pushes it over the mouth of the shaft. The bucket which

is permanently fastened to the rope by the wrought-iron bow *s* is now lowered, emptied into this car, and again raised into position ready for lowering into the shaft. The car is now run back from the mouth of the shaft, and the rock, etc., unloaded.

The wrought-iron bow *b* (Fig. 430) of the bucket is attached to it at a point below the center of gravity, so that when full the tendency is for the bucket to turn over and empty itself. To prevent this while hoisting, a short vertical pin *g* is riveted to the side of the bucket, and an ordinary chain link sliding on one arm of the bow passes over it.

**1472.** Covering the mouth of the shaft with a traveling car while sinking is open to a great number of objections, to overcome which the arrangement of levers and counterbalances shown in Fig. 431 may be used.

Each door is bolted to two hinges *d, d*, which are keyed

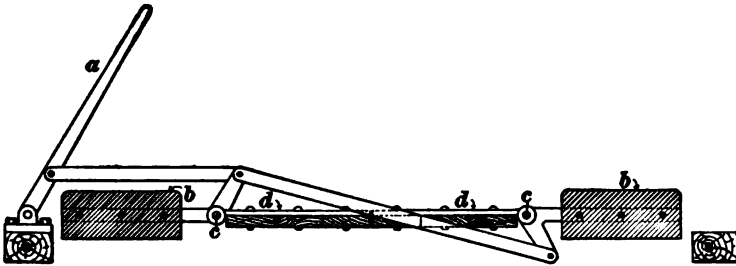

FIG 431.

on shafts *c, c*. By means of the handle *a*, and the connecting arms, a rotary movement is given and the doors lift as the lever is pulled back. The weight of the doors is counterbalanced by four blocks *b, b*, so that they will stand at any position desired.

**1473. Sinking Guides.**—The oscillation of the bucket in deep sinking becomes very great, and much time is lost in steadying the bucket before it starts upwards. The best method to overcome this is shown in Fig. 430. The guide ropes *c, c* are coiled on a drum at the surface so that they can be lengthened as the sinking advances. These ropes

have large weights attached to their lower ends in the shaft to keep them steady. An iron frame, called the **rider**, consisting of two legs joined together by a cross-bar, clasps the two guides loosely at the four points *d*. The winding rope passes through a hole in the center of the rider.

Sometimes the permanent guides are put in at the same time the shaft timbers are placed, in which case the ropes *c*, *c*, Fig. 430, are not required.

**1474.** The shaft sinking is continued, with or without timber, as the strength of the strata may require, far enough below the coal to make a "lodgment" for the water. The size should be the same as the section of the shaft, but the depth will depend upon the amount of water. When the seam has a considerable dip, a large lodgment can be made in it by excavating galleries to the dip of the shaft in the coal, and leaving a solid barrier all around to prevent the water making its way into the dip workings. The water is pumped from this lodgment through a slanting suction pipe, or a level tunnel connects the lowest point of the lodgment with the sump bottom, which is the continuation of the shaft.

**1475. Shaft Ventilation.**—This is accomplished by constructing a midwall between the pump and the hoisting compartments, which must be perfectly air-tight. This can best be made by putting up a double lining of selected tongued and grooved lumber, or well selected boards, placing a sheet of heavy tarred paper between the double lining. For the first few yards there is no difficulty in supplying air, provided the midwall closely follows the sinking, as the moving bucket creates a current. When this fails, the smoke may be driven out by pouring a barrel of water down the shaft, or by hanging a "fire lamp" temporarily within the shaft. When the less effective devices fail to produce the required ventilation, a steam jet may be used.

Chokedamp and firedamp are both found in sinking shafts, and the former has caused several fatalities at a shallow depth from the surface. The shaft should be carefully examined before the sinkers enter, especially when there is any interval between the shifts going off and coming on.

## CIRCULAR SHAFTS.

**1476.** Circular shafts are rarely used in North America, yet there have been a few instances where the circumstances were such that the circular form was imperative, the most conspicuous being the Princess Pits, of Sydney Mines, Cape Breton, Nova Scotia. The winding shaft is 13 feet in diameter and 682 feet deep; the pumping shaft close by the winding shaft is 11 feet in diameter and 709 feet deep. There is also a staple, or auxiliary, pumping shaft 389 feet deep from the surface.

At the depth of about 200 feet, a feeder of water was met which was successfully overcome by pumping, but at a depth of 267 feet, water came in through fissures in the thick bed of sandstone directly from the sea. This had to be shut off by lining the shaft with cast-iron tubing.

Fig. 432 shows a section of the shafts on a small scale, in which *d* is a cross-cut through which the water flows from pumps in shaft *C* to pumps in the staple shaft, and *e*, *f*, *g*, and *h* are cross-cuts made between the shafts to facilitate the process of sinking; these latter cross-cuts are closed off by the tubing.

The tubing plates for this kind of work are cast in segments of such length that the circumference is divided into equal parts, their height varying from 18 to 36 inches, according to the pressure to be resisted. A **closer**, which is a section of tubing used to connect a lower stage of tubing with the crib of the stage above, must generally be made an odd size.

Nine segments complete the circle in the *B* pit, or winding shaft (Fig. 432), eight segments in the *C* pit, or pumping shaft, and five segments in the staple pit, or auxiliary pumping shaft.

**1477.** The confinement of air and gas behind the tubing may cause a water blast. No matter how thick the tubing may be, a water blast will break it, or displace it from its seating. To guard against this in the shafts at Sydney, a 4-inch brass valve was placed in each crib at the

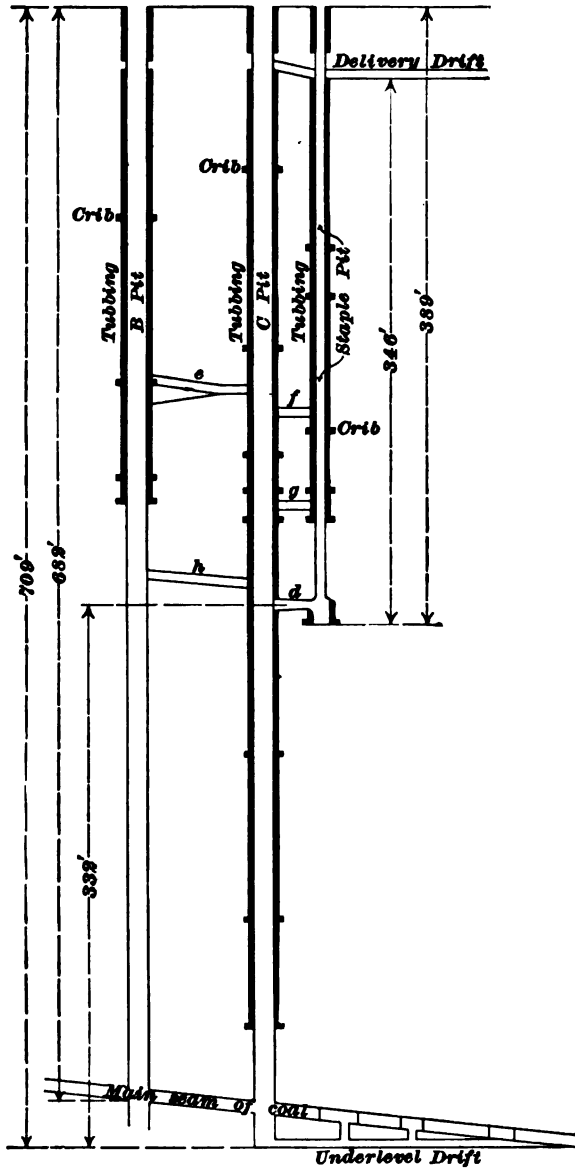

FIG. 432.

back of the tubbing to allow the air to pass freely from the lowest to the highest lift. Also, each segment of tubbing had a hole of  $1\frac{1}{4}$  inches diameter through its center (see section *a*, Fig. 433) to let the air escape during the process of wedging; these holes were plugged when the wedging of the joints was completed.

**1478.** A wedging curb in wet strata can only be located at a good *b* hard stratum of rock, which must be dressed down with chisels and cut to a perfectly level and even surface. When the wedging curb or wedging crib of eight segments—more or less, as the case may be—is laid on the perfectly cut *a* bed, and wedged up securely, the segments of tubbing are built upon it, breaking joints with each other as shown in section *a*, Fig. 433.

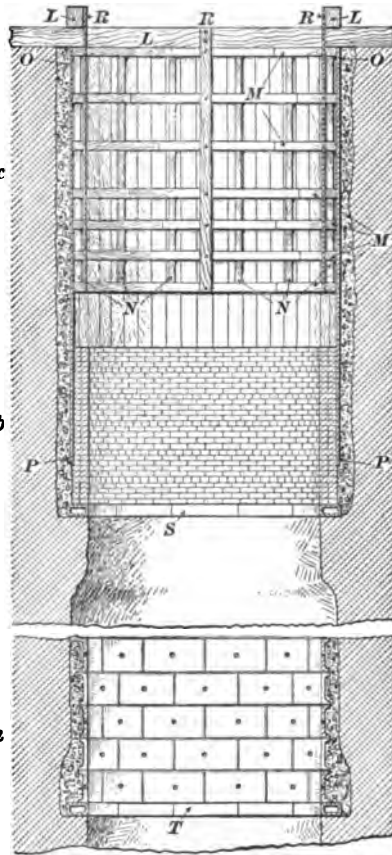

FIG. 433.

**1479.** The top and one of the side flanges of each segment are provided on the outside with a projecting ledge ( $\frac{1}{4}$ ' deep at Sydney mines) which keeps the joint sheathing and adjoining segments in position.

When the segments are being put in position, sheathing (usually pine  $\frac{1}{2}$  inch thick) is placed between both horizontal and vertical joints, and a wedge tightly driven down between

the back of the plate and the side of the strata to prevent any movement of the segments.

When a number of courses of tubing have been set up in place, all joints are wedged up; that is, small wedges of red pine are inserted in the sheathing and driven in until the wood becomes compressed so hard that the chisel edge can not be driven into it.

The tubing is put up in lifts or sections. A lift or section at Sydney mines consisted of a wedging curb and from five to fifty courses of tubing built thereon.

**1480.** The following formula is used for calculating the proper thickness for cast-iron tubing:

Let  $t$  = thickness of tubing in inches;  
 $d$  = diameter of shaft in feet;  
 $D$  = depth in feet;  
 $G$  = the crushing load of cast iron per square inch;  
 usually taken at 90,000 pounds.

$$t = \frac{6d\sqrt{G} - 6d\sqrt{G - 6.944D}}{\sqrt{G - 6.944D}} \quad (86.)$$

$$= \frac{1,800d - 6d\sqrt{90,000 - 6.944D}}{\sqrt{90,000 - 6.944D}}, \text{ when } G = 90,000.$$

The upper course of tubing should in all cases be at least  $\frac{1}{4}$  of an inch thick in the plate, even in shafts of very small diameter; and  $\frac{3}{8}$  of an inch thick in shafts of large diameter, to prevent liability to fracture. It is also desirable to add a constant, usually  $\frac{1}{8}$  of an inch, to the thickness obtained by the formula, to allow for wear and tear, and for corrosion or other chemical action on the metal.

In this formula, no allowance is made for the extra strength given the segments by the flanges and ribs. Theoretically, each set of segments should have a different thickness, but in practice they are calculated for every 25 or 30 feet.

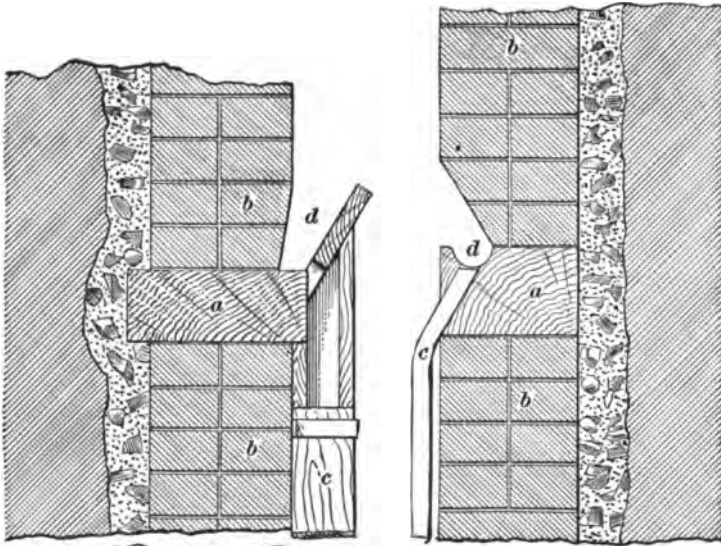

FIG. 434.

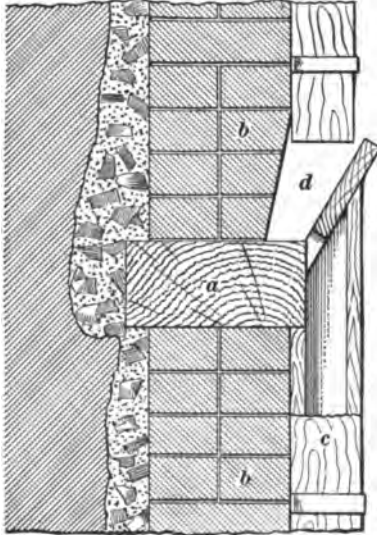

FIG. 435.

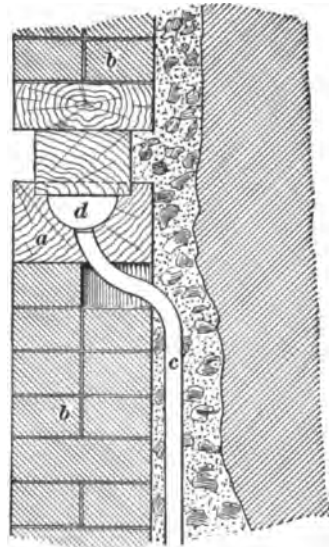

FIG. 436.

EXAMPLE.—What should be the thickness of cast-iron tubing for a shaft 13 feet in diameter at a depth of 800 feet, allowing  $\frac{1}{4}$  inch for rust ?



**SOLUTION.**—By substituting these values in the preceding formula, we have

$$t = \frac{1,800 \times 13 - 6 \times 13 \sqrt{90,000 - 6.944 \times 800}}{\sqrt{90,000 - 6.944 \times 800}}$$

$$= \frac{23,400 - 6 \times 13 \times 290.6}{290.6} = \frac{23,400 - 22,666.8}{290.6} = 2.523 \text{ in.}$$

Now, adding  $\frac{1}{4}$  in. for wear and tear, we obtain thickness = 2.523 + .125 = 2.648 in. Ans.

**1481.** Fig. 433 shows the timber lining, brick walling, and tubing employed in circular shafts, each, of course, being applied under different conditions.

*L* shows the timbers laid across the top of the shaft, *M* the timbering curve, *N* the punch blocks, *O P* the backing plank, *R* the stringing board, *S* the walling curb with the walling upon it, and *T* the hollow cast-iron wedging curb with cast-iron tubing resting upon it.

**1482. Water Rings.**—Scarcely any strata which require walling will be perfectly dry, consequently water will percolate through the brick. It is caught in water rings, garlands, curb rings, ring curbs, or ring gibs that are put in, and from which the water is conducted to the sump through a line of pipes.

Figs. 434, 435, and 436 show the details of construction of several styles of water rings. In each figure, *a* is the crib, in which a gutter is usually hollowed out to catch the water, *b* is the walling both above and below the crib, and *c* is the waste pipe which conducts the water down the shaft from the gutter *d*.

**1483. Brick, Stone, and Wood Walling.**—When the shaft has been sunk deep enough for a walling staging, the seat for the segmental wedging curb is cut and the sinking carried down 5 or 6 feet, more or less as the case may require, below the curb, at the same diameter as the internal

diameter of the curb (see *a a*, Fig. 437). The walling at *A* is carried on simultaneously with the sinking at *C*.

When the walling *A* reaches the projection *a* above, the projection is gradually cut away and the walling *A* carried up and fitted closely to the previously constructed portion above.

The guides *c, c* are fastened at the surface, as stated in Art. 1473; but here, instead of having weights attached to their lower ends, the building scaffold *ss* is attached, as shown in Fig. 437. The platform *ss* has a hole in the center, through which the bucket passes, and is permanently suspended in the shaft by the guide rods *c, c* at a height not exceeding 45 to 60 feet above the bottom.

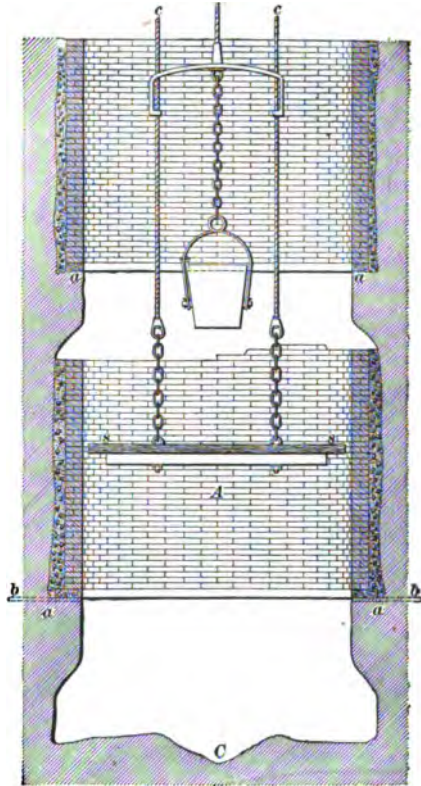

FIG. 437.

**1484.** The walling shown in Fig. 437 is either brick or stone, but in some cases wood is used. Fig. 438 represents such a case. The blocks are cut out of the best oak (all heart stock). They are about 3 feet long by 9 inches square. The joints are cut in radial lines, so that when the blocks are put in place they fit snugly and can not be pressed inwards.

The curb upon which this walling rests is likewise of wood. Between it and the ground is a space of about 6 inches in which there is placed a piece of wood *a*, about 2 inches thick, and between it and the ground the space

is filled with compressed moss *m*. Wedges *w* are then placed between this 2-inch strip of wood and the curb, and tightly driven in, thereby compressing the moss still more.

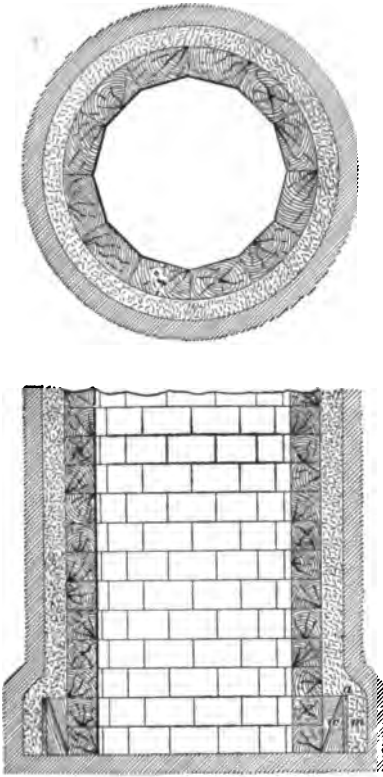

FIG. 438.

rectangular brick. Some prefer the ends, and others the sides, curved to correspond with the inner and outer circumference of the shaft lining, while still others prefer to have the bricks molded into a form to suit the special case.

Good hard-burned rectangular brick, free from clinkers and pebbles, with a fairly rough face which ensures that they have not been over-burned, are the best.

Some engineers prefer to have all brick laid with the long side in line with the shaft diameter, while others prefer the

**1485. Supporting Curbs.**—Sometimes, in passing through broken strata, it is necessary to put in a supporting curb. There are several ways of doing this, but perhaps as good a way as any is to drill holes into the wall about 2 feet apart, taking great care to have them in a horizontal plane. Then the curb will be level when resting on bars of iron or steel, 2 or 3 inches in diameter, inserted in these holes. See *b*, Fig. 437.

**1486. Bricks.**—The dimensions of bricks for shaft lining vary, many engineers preferring under all conditions the ordinary

brick laid with the long side running with the circumference, every fourth or fifth course being laid contrariwise, as binders.

**1487.** There is no definite rule for determining the number of bricks required for shaft lining, on account of chipping and mortar, but an approximation may be made by the use of the following formula:

Let  $N$  = number of bricks required;  
 $D$  = outer diameter of the shaft;  
 $d$  = inner diameter of the shaft;  
 $t$  = thickness of brick;  
 $b$  = breadth of brick;  
 $l$  = length of brick;  
 $x$  = depth of shaft.

$$\text{Then, } N = \frac{(D^2 - d^2) \times .7854 \times x}{t \times b \times l}. \quad (87.)$$

All dimensions must be in feet, or all in inches.

**EXAMPLE.**—If the outer diameter is 18 feet 6 inches, the inner diameter 18 feet, and the depth of the shaft 100 feet, and the size of the bricks is 8 inches by 3 inches by 4 inches, how many bricks will be required to line the shaft?

**SOLUTION.**—Substituting values, we have

$$N = \frac{(18.5^2 - 18^2) \times .7854 \times 100}{.25 \times .3333 \times .6666} = 25,800 \text{ bricks. } \text{Ans.}$$

As before stated, this is only an approximation, for as a general thing the number of bricks found by this formula will be from 10% to 15% more than will be required.

**1488. Mortar.**—In shaft lining, mortar should be used sparingly, and when water is to be resisted, good Portland cement should be used. In less important work, use equal parts of cement, lime, and ground ash clinkers (sand is too heavy) well mixed. To avoid getting mortar joints too thick, let the mason spread his mortar at a little distance from the spot where the brick is to set, then place the brick in it and slip it by gentle pressure into its proper place. The brick will carry sufficient mortar with it for its bedding.

**1489. Substitute for Timbers.**—Instead of putting in temporary timbers, as shown in section *c*, Fig. 433, the following method, which is better, is sometimes used: Four iron bands, 3 inches by  $3\frac{1}{4}$  inches, of such length that combined they will be equal to the circumference of the shaft, with additional length for overlap so that they can be bolted together, are placed in position, and lagging is driven between them and the side of the excavation.

To prevent bulging of the wall, no cavities should be left between it and the strata. Some soft, compressible stuff, such as coke dust, should be used for filling, or if that can not be had, sand may be used.

**1490. Uses of Curbs.**—With any form of walling which must be water-tight, whether wood, stone, brick, or cast iron, a wedging curb is used.

Ordinary curbs are used where any form of walling not necessarily water-tight is used.

Supporting curbs are the same as the ordinary curbs, but are put in under different conditions, which have already been mentioned.

The "ordinary curbs" were formerly nearly always made of wood; but, as they are subject to decay, cast-iron curbs are beginning to supersede them.

**1491. Plumbing the Shaft While Sinking.**—In the rectangular and polygonal forms, a plumb line must be hung from each corner. In a circular shaft, a line may be hung in the center, and the sides of the shaft determined by a rod of the proper length reaching from the plumb line to the circumference. A better plan is to hang four plumb lines, one from each extremity of two diameters crossing each other at right angles. In an elliptical shaft, four plumb lines are hung, one at each extremity of both the major and minor axes. The plumb lines are fixed on a reel, so that the plumbs can be lowered as the sinking advances.

**1492. Cement Tubbing.**—Fig. 439 shows a method of lining shafts with cement, practised in some parts of Prussia.

This process has been found to offer great advantages in cases where the pressure is excessive. The cement blocks used are so shaped that they can be made perfectly water-

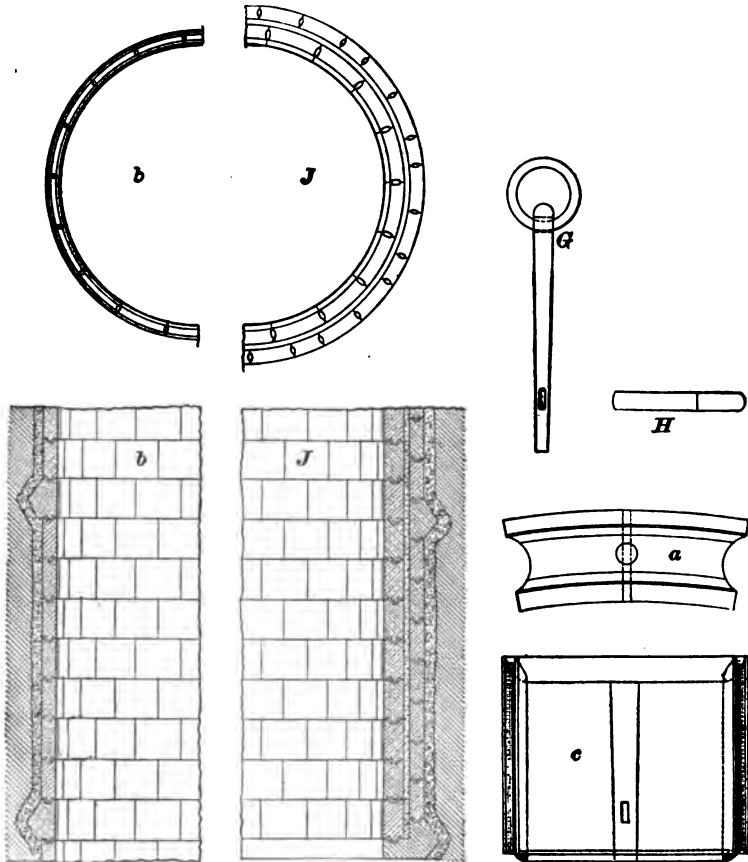

FIG. 439.

tight and will admit of easy setting. The shape of the blocks is apparent from the views *a* and *c*, Fig. 439. They are segmental, and are provided on the lower side with a semicircular groove, which corresponds with a semicircular ridge on the upper side, the groove being slightly deeper than the corresponding ridge, so that space is available for the reception of cement-mortar. On each side of the block

there is a channel for the reception of cement, the weight of the block being in this way reduced. In each block two holes are cored out, one of which is central and vertical, while the other passes radially from front to back, not in the middle of the block, but at some distance below that point, and intersects the vertical hole. The height of a block is 30 inches to 40 inches, and its weight from 1,500 to 1,700 pounds.

**1493.** In tubbing a shaft with cement blocks, the first layer of segments must be laid on the curb, on this the second layer, and so on, the vertical joints being broken in each course. In order to place a segment in position, a rod, provided with a ring or handle at the top, and with a slot near the lower end, is placed in the vertical hole. (See *G*, Fig. 439.) This rod is pushed down until the slot is opposite the horizontal hole, and then a bar *H* is pushed through, until it passes through the slot and holds the rod fast in the block. The winding rope may then be connected with the ring of the rod and the block lowered into position. Previously, however, the trough in the block below is filled with cement-mortar. When lowered, the ridge of the block coming in contact with the mortar forces it into every crack, and a water-tight connection is effected between the horizontal layers of blocks. The vertical hole is then filled with a lump of clay which is rammed in, and a bar is pushed through the horizontal hole, which has become choked at the point of intersection, and the hole is reopened. The bar is allowed to stay until the clay has hardened. On withdrawing it, a channel is formed, through which the water collecting behind the tubbing can flow. Between every two blocks a tubular joint is formed, which is filled with cement-mortar or concrete rammed in as tightly as possible. The horizontal holes, which had hitherto served as drainage channels, are closed by cork, wood, or clay; and if, at a certain height in the shaft, there is a supply of good water, it can, without difficulty, be piped away.

When the segments are formed into a complete ring, the perpendicular grooves are filled in with a special mixture of

cement, and concrete is rammed into the space between the segments and the sides of the shaft. Above each cement block a thin layer of cement is spread, and on this the segments of the ring above are placed. (See *b, b*, Fig. 439.)

In some cases a double ring of cement segments is employed (*J, J*, Fig. 439). Here a course of cement blocks for the back wall is first laid, and cement rammed in behind. This course is about half a block higher than the inner layer, so as to break the horizontal joints. The courses of the inner ring are then laid in such a way that the vertical joints do not coincide with those of the back ring. The joints are carefully filled with cement, and the intermediate space of about 4 inches between the inner and outer rings is then filled in with concrete tightly rammed. In this manner a thoroughly water-tight tubing is obtained.

**1494.** In shaft sinking, cement is found to be a valuable auxiliary, particularly in the special setting of masonry known as coffering. Cement, too, has been employed in an ingenious way for consolidating shifting sand in water-bearing strata. The method employed consists in injecting powdered cement, by means of compressed air, steam, or water under pressure, into the ground to be consolidated. The cement is screened in order to free it from lumps, and the powder is taken by an injector which forces it through a flexible pipe into a perforated tube sunk in the soil to the required depth. In this manner the soil becomes impregnated with the powdered cement, while the water is driven away from it.

---

### THE PROCESS OF SINKING.

---

#### DRILLING.

**1495.** When, in shaft sinking, ground is reached that is too hard to be excavated by the sinking pick (which is simply a heavy pick made like the ordinary mining pick) and wedges, explosives are used. The operation of blasting consists in boring holes of suitable diameter and length in favorable positions in the pit bottom, in inserting the charge of



the explosive compound in the lower portion of the hole, in filling up and ramming with suitable material the remaining portion of the hole, and in exploding the charge. These holes are made either by "churn drills," "jumpers," or power drills.

**1496.** The **churn drill** is a bar of round iron, swelled in the center to give weight, having a bit on each end. This is raised and forced down by the hands of one or two men in the same manner as a percussion boring machine makes its stroke. It is turned slightly at each stroke to keep the hole round.

In the shaft bottom the conditions are frequently such that the holes must be drilled at different angles. So long as the boring is vertically downward, or the angle from the vertical is slight, the churn drill is very effective. But in sinking operations, holes must be drilled at all angles, and it is obvious that in some of these directions the churn drill is practically worthless. To meet these conditions, the ham-

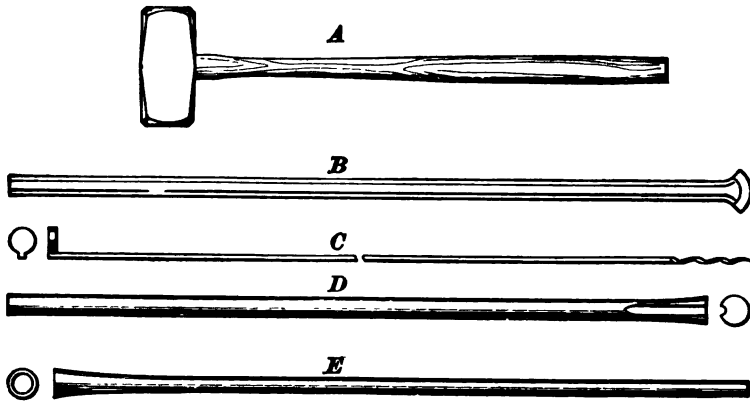

FIG. 440.

mer and jumper shown in Fig. 440 are used. This figure shows a set of double hand rock tools.

*A*, sledge hammer, weight 5 pounds or more.

*B*, drill, of which there are usually three in a set, the dimensions being 18 inches long, with  $1\frac{1}{4}$  inches cutting

edge; 27 inches long, with  $1\frac{1}{4}$  inches cutting edge; 40 inches long, with  $1\frac{1}{2}$  inches cutting edge.

*C*, scraper and drag-twist.

*D*, rammer, or copper-headed tamping bar.

*E*, bêche.

**1497.** The method of using these tools is as follows: The hole having been started, the short drill is inserted and held in position by one man, while the other, called the "striker," strikes the top of the drill with the sledge hammer. The man holding the drill gives it a slight turn after every blow so as to ensure a round hole. After the short drill has gone in about half way the second drill takes its place, and after that the long drill. The scraper is a thin iron rod with a round, flat end, turned up at right angles to the stem, for the purpose of scooping all the sludge and débris from the hole. The drag-twist at the other end of the scraper is a spiral hook. To ensure the hole being thoroughly clean and dry, a wisp of hay is pushed into the hole and the drag-twist is then inserted until it becomes entangled in the hay, which can then be removed.

When the hole has been cleaned, the charge of explosive is inserted and the fuse laid to it. The hole now needs tamping, and this is done by plugging it up by means of the tamping bar *D*. It will be observed that there is a groove cut out along one side of this tool, the object of which is to allow for the space occupied by the fuse along one side of the hole, when the clay is being tamped or rammed. The bêche *E* is simply a rod with a tapered hollow end for the purpose of extracting a broken drill, if necessary.

**1498.** In extra hard rock the diamond drill, shown in Fig. 441, and the rock drill, a type of which is shown in Fig. 442, have been used to advantage. These may be operated by steam or compressed air; the latter is most commendable for the comfort of the sinkers, but from a point of economy steam may take precedence.

The drill shown in Fig. 441 may be operated by hand, if

it is so desired. If the number of revolutions is great, the diamonds in the bit pass very rapidly over the surface, wearing it lower and lower, and thus the bore hole is carried down, the machine stopping only when the core barrel is filled with the core of the strata, or when another length of rod must be attached. The hole may be drilled any

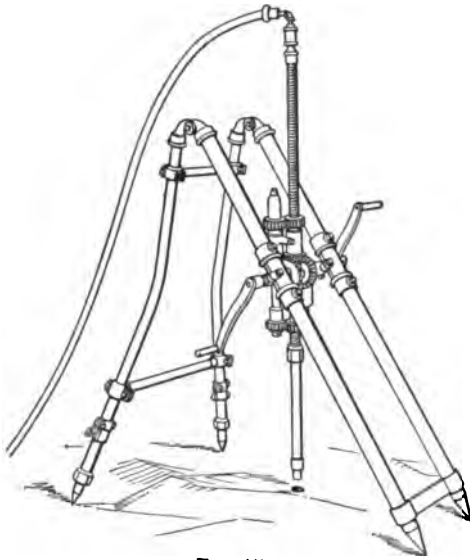

FIG. 441.

depth, the blasting being regulated by filling the hole with sand, which is removed as further depth is required.

**1499.** Fig. 442 is a percussion drill which may make as many as 500 double strokes per minute. The mechanism slightly turns the drill at each blow, which results in a circular hole of a diameter a little larger than that of the cutting tool. As the drill works, the sinker turns the handle of the advancing screw *A*, and so causes the cylinder to move down the slide *B*, thus keeping the point of the drill up to its

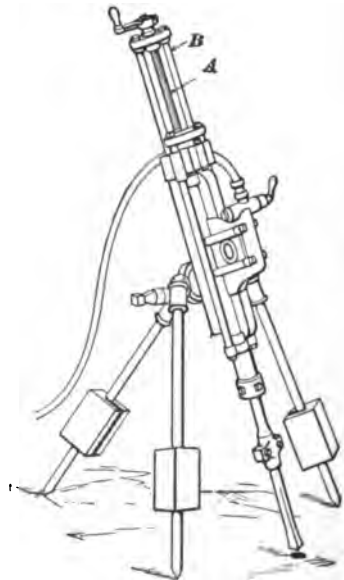

FIG. 442.

work. This slide being say 18 inches long, the hole can be drilled that depth. When this depth is reached the screw is reversed, the drill drawn out of the hole, and a longer drill placed in the hole and fastened to the piston. The second drill is rather narrower than the first, so that it will not catch on the sides of the hole. When the entire length of this drill has been bored, if it is still necessary to go deeper, a third and then a fourth drill can be added.

Percussion drills may be used to put in any number of holes desired, and at any angle. The number of holes and their position will depend upon the form and size of the shaft. The holes generally vary in depth from 3 feet to 4 feet, and in diameter from  $1\frac{1}{2}$  inches to  $\frac{3}{4}$  inches.

Sumping holes are the first holes drilled and fired in a level pit bottom. They should be placed near the center, and inclined at an angle of from 20 degrees to 40 degrees, and should not be too deep, say 3 feet in hard rock.

---

#### BLASTING BY FUSE.

**1500.** In blasting by fuse, frequently four or more holes are lighted at the same time, lengths of fuse being used, so that the shots go off one after the other, allowing each detonation to be counted, so that the sinkers may know if all have fired. Fuse blasting is objectionable, because, under many conditions of sinking, the simultaneous discharge of blasts gives the best results. As each shot mutually assists the other, the result is about 1.4 times as powerful as that obtained from consecutive firing. Fuse firing is dangerous, because the fuse may hang fire.

Time fuses are in use at present, but they can not be relied upon under all circumstances, and especially when subjected to the varying conditions of damp holes. Time fuses are made of cotton or hemp, either single tape or double tape. Some are made of gutta percha, and others of an outer and inner casing of special material, according to the conditions under which they are to be used. The best is inferior to the electric exploder.

**1501.** In firing ordinary powder with a fuse, the fuse is first cut to obtain a fresh surface. One end is doubled back and fastened by a string loop. It is then inserted in the cartridge, as shown in Fig. 443, and the mouth of the cartridge carefully drawn together and tied. It is now ready to be lowered into the hole. By using a gutta percha fuse and water-proof paper, wet holes are frequently fired with black powder.



FIG. 443.

**1502.** With nitroglycerin explosives, a percussion, or detonating, cap is placed on the end of the fuse and inserted in the cartridge. Safety in the use of high explosives requires extreme care. Sharp pieces of metal—a knife blade, for example—should not be brought in contact with the cartridge. The fuse is inserted in the detonator, and the end of the latter is “crimped” so as to firmly hold the fuse, as shown in Fig. 444. It is bad practice to attempt

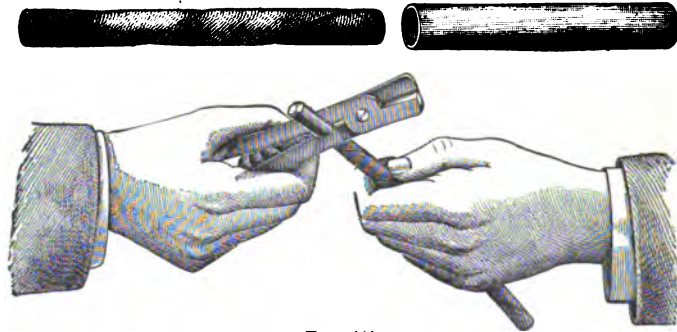

FIG. 444.

to secure the cap to the fuse in any other way, as the detonator is liable to explode and cause a serious accident. Having secured the cap to the end of the fuse, open the end of the cartridge, and, with a sharpened piece of wood, punch a hole in the end of the cartridge large enough to receive the cap, but do not insert the cap so far that there will be any danger of the burning fuse starting a deflagration of the cartridge before it is detonated.

The cap should be inserted only  $\frac{1}{4}$  of its length to avoid such an occurrence. After inserting the cap, close the end of the cartridge, and tie securely with a string, as shown in Fig. 445. The cartridge so prepared is called the **primer**.

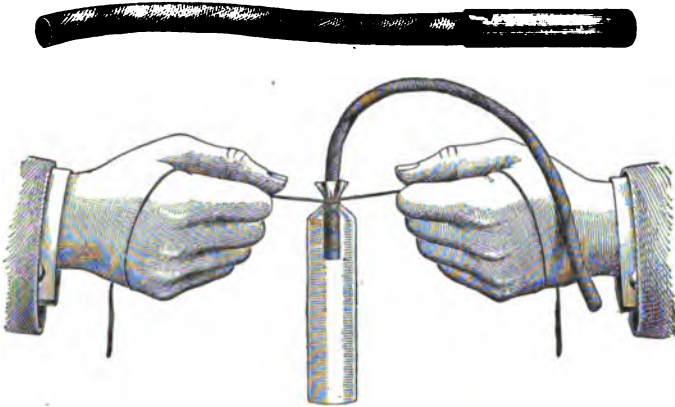

FIG. 445.

When a number of cartridges are inserted in the same hole, the detonation of the *primer* is sufficient to explode the entire charge. The size of the cartridge should be such as to fit fairly snugly in the hole. The cartridges must be inserted and pressed home carefully, one by one, the primer being inserted last and pressed tightly down upon the charge, and then the "*tamping*," or "*stemming*," should be inserted.

**1503.** Holes are charged by putting in one or more cartridges, and squeezing each with a wooden rammer. The best tamping for a drill hole is that which will not blow out; it must be of a strong resisting character—something which changes form when disturbed, and which tends to wedge. The best tamping, except small stones, is sand, and the worst is wet clay. If substances which are near at hand will serve the purpose, they had better be used.

The power of the explosion is improved by good tamping, because it confines the forces generated by the blast within the hole. In order that even nitroglycerin explosives may be well tamped, a soft substance, such as clay, is put directly

on top of the cartridge, and gently pressed home; on top of this, the tamping may be rammed tighter and tighter as it comes nearer the top of the hole.

#### ELECTRIC BLASTING.

**1504.** The American method of electric blasting depends upon the generation of a current of electricity in a similar manner to the production of electricity for lighting purposes, the current producing incandescence in a wire which is submerged in an explosive. A magneto-electric machine is simply a small dynamo operated by hand, the electric current being produced by the rapid revolution of an armature, or a coil of wire, between the poles of a magnet. The current is generated in the machine, and when it is at its greatest intensity, it is discharged into the circuit which contains the exploder. In this way the electric current passes over a fine platinum wire bridge, which offers so much resistance that the wire becomes red hot, and this heat explodes a small quantity of fulminate of mercury which is in the cap.

**1505.** Fig. 446 shows a cap with wire connections. The wires *C*, leading from the battery, are connected by a fine platinum bridge *E D*. *F* is a cement, usually made of sulphur, for the purpose of holding the ends of the wires intact,



FIG. 446.

and serving to seal the mouth of the exploder. *B* is the fulminating mercury. The whole is encased in a tube *A*, which is similar in appearance to a gun cartridge. It is about  $1\frac{1}{4}$  inches long and  $\frac{1}{4}$  inch in diameter. The wire *C* should be of pure copper, of about No. 20, American wire gauge, and well insulated by cotton or other substance, wound double over the wire.

The passage of electricity through any substance is practically instantaneous when compared with the passage of

heat. Therefore, in a hole where there are several cartridges, to ensure immediate explosion of all of them, an exploder should be placed in every second or third cartridge; the best result will be secured if there is an exploder in each.

When blasting is done under water (the result accomplished is then only  $\frac{1}{4}$  that of dry blasting), and whenever the explosive is gelatin, gun-cotton, forcite, or dynamite, the double strength exploder should be used.

**1506.** The greatest explosion that can be made is produced when the detonation is sufficient to ensure the immediate explosion of the entire charge. If dynamite which has frozen is not thawed out, it will take a much higher initial explosion of detonation to set it off. In some cases, several ounces of powder are put in the hole in contact with the exploder and on top of the dynamite, in order to produce the large amount of shock and heat to discharge the higher explosive—dynamite.

**1507.** The explosion is simply the conversion of the solid into a gas. The gas occupies more space than the solid; hence, in the tendency to expand it breaks the rock. The higher the grade of the explosive the more sudden is the conversion into gas, and the more effective is the blow which it delivers in the drill hole. This suddenness of conversion into gas is sometimes of more importance than the number of volumes of gas produced by a certain number of cubic inches of the explosive, as it increases the amount of work done.

**1508.** For firing by electricity, two systems of connecting the wires to the machines are in use. In the first, Fig. 447, the fuses are connected in **series**; that is to say, one wire of the first hole is connected to one wire of the second hole, and the other wire of the second hole to one wire of the third hole, and so on, until all are joined, when there will be one wire of the last hole and one wire of the first hole left unconnected. These are now joined by wires to the machine, which is in a place of safety.



In the second, Fig. 448, the fuses are connected in

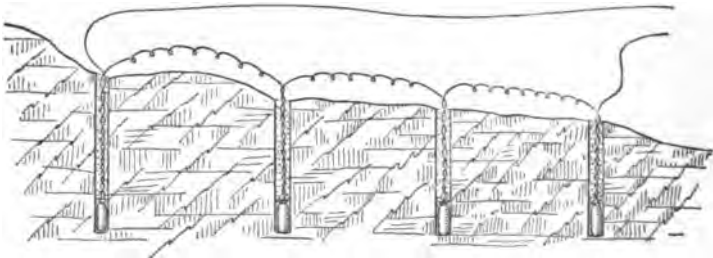
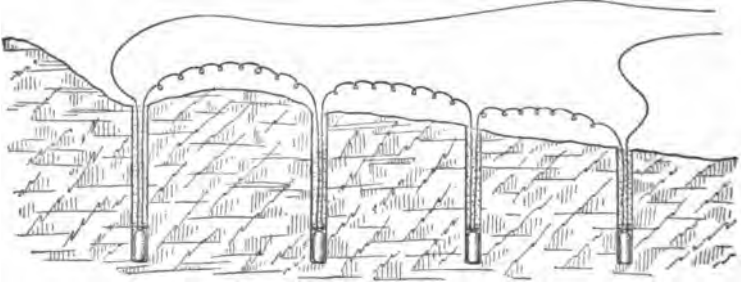

FIG. 447.

**parallel.** In this case the positive wire of each detonator is connected directly to the positive wires from the machine,

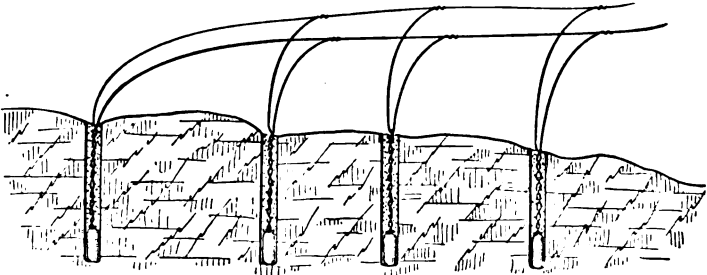

FIG. 448.

and the negative wire is connected to the negative wire from the machine.

Modifications of the "series" and "parallel" systems are possible, as the holes may be connected in multiple series, as shown in Fig. 449.

**1509.** The connecting wire, sometimes called the fuse, varies with the length of the hole.

The making of the joints which connect the wire from the

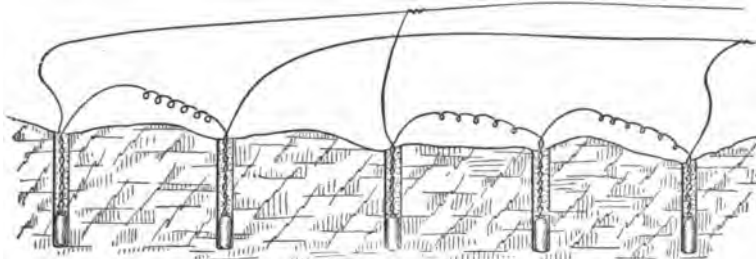

FIG. 449.

battery with the fuse is not so simple an operation as would appear. The first thing to do is to bare the wires; if they are already bare, it is best to use a knife to scrape them, thus removing all oil or other material which may interfere with a perfect connection. Two points must be observed. One is to bring the two wires in thorough contact with each other, and the other is to so connect them that they will not pull apart. In order to do this, both wires should be twisted in the manner shown in Fig. 450.

The two ends should be brought together with both hands, and, by means of each thumb, twisted alternately, one wire

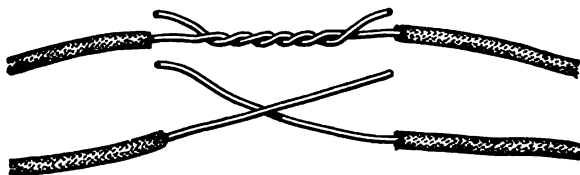

FIG. 450.

around the other. In this way they are not only brought into perfect contact, but they are tied together.

Connecting wire is usually made of copper, because of its high conductive power.

With machine drills and electric, or simultaneous, blasting, there is not so much necessity to consider the line of least resistance, but it should be taken advantage of as often as possible.

**1510. Electric Blasting Apparatus.**—Fig. 451 shows a good type of magneto-electric machine, weighing about 16 pounds and occupying less than  $\frac{1}{4}$  a cubic foot of space. These machines are of different capacities; one kind will fire 15 holes, while another kind will fire from 25 to 40 holes. With these machines no uncertainty exists.

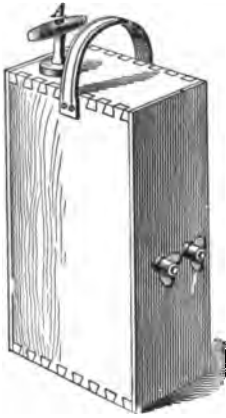

FIG. 451.

In using these machines a fuse, or exploder with two wires attached, is used as already described. The charges having been connected as directed (the leading wires being long enough to reach a point at a safe distance from the blast) and all being ready, the workmen connect the leading wires, one to each of the winged nuts on the front side of the machine. This is accomplished by placing the wire between the nut and the shoulder and tightly screwing the nut against the wire.

To fire, take hold of the handle *A* and lift the rack (or square rod, toothed upon one side) to its full length, and press it down, for the first inch of its stroke with moderate speed, but finishing the stroke with all force, bringing the rack to the bottom of the box with a solid thud, when the explosion will take place.

#### EXPLOSIVES.

**1511.** M. Berthelot describes nitroglycerin as “really the ideal of portable force. It burns completely without residue—in fact, gives an excess of oxygen; it develops twice as much heat as powder, three and a half times more gas, and has seven times the explosive force, weight for weight, and taken volume for volume, it possesses twelve times as much energy.”

**1512.** The name “high explosives” is generally applied to that class of explosives of which nitroglycerin is the active principle. They are commonly known by the

name of **dynamite**. This usually burns freely without explosion when unconfined in the open air, but when fired by a blasting cap it explodes with enormous force.

All nitroglycerin compounds freeze at 40° F., and resume their soft, pasty condition upon being warmed. To secure its full explosive power, dynamite must never be used in even a semi-frozen state. All nitroglycerin compounds decompose when exposed to the direct rays of the sun for any length of time, whatever the temperature of the air may be, and hence lose their efficiency. All frozen cartridges should be thawed; as, when frozen, the powder loses much of its efficiency, its properties change and it is difficult to explode it with a cap.

**1513.** When the cartridges are frozen, they should not be exposed to a direct heat, but should be thawed by one of the following methods:

1. The number of cartridges needed for a day's work should be placed on shelves in a room heated by steam pipes or a stove. If a small house is built for this purpose, it should be banked with earth, or preferably fresh manure.

2. The cartridges may be put in a water-tight kettle and this placed within a larger kettle, filling the space between the kettles with water at 130° F. to 140° F., or at such a heat as can be borne by the hand. If the water cools, it should not be reheated in the kettle, but fresh warm water should be added. The kettles should be covered to retain the heat. The temperature should not be allowed to get above 212° F.

3. When the number of cartridges to be thawed is small, they are sometimes placed about the person of the workman until he is ready to use them, but this is a dangerous practice.

Cartridges should not be thawed by putting them in hot water or by exposing them to live steam, as this (unfortunately very common) method has an injurious effect on the powder. Neither should they be thawed by holding them in the hand before a fire. Cartridges exposed after

thawing freeze again rapidly. They may be carried to where they are to be used in sawdust in a box, so as to prevent their freezing.

**1514.** The following table, by Berthelot, gives a valuable statement of the heat, volume of gas, and the explosive force (relatively) of prominent explosives:

**TABLE 30.**

Substance.	Heat.	Volume of Gas.	Estimated Explosive Force.
Blasting powder.....	510	0.173 liter	88
Artillery powder.....	608	0.225 liter	137
Sporting powder.....	641	0.216 liter	139
Powder, nitrate of soda for its base.....	764	0.248 liter	190
Powder, chlorate of potash for its base.....	972	0.318 liter	309
Gun-cotton.....	590	0.801 liter	472
Picric acid.....	687	0.780 liter	536
Picrate of potash.....	578	0.585 liter	337
Gun-cotton, mixed with chlorate of potash.....	1,420	0.484 liter	680
Picric acid, mixed with chlorate of potash.....	1,424	0.408 liter	582
Picrate, mixed with chlorate of potash.....	1,420	0.337 liter	478
Nitroglycerin.....	1,320	0.710 liter	939

NOTE.—A *liter* is equal to 61.027 cubic inches.

### SPECIAL SINKING DEVICES.

**1515.** In Europe many special devices are used for sinking shafts under difficulties, as through quicksand, heavy feeders of water, etc. It does not seem probable that all of these methods will be entirely successful in this country. They may be modified to meet the peculiar con-

ditions of each case; but these modifications must, in some respects, be radical, and the best results will be obtained by adopting from each of the several systems the methods and appliances that are best suited to the case.

In order to pass through quicksand, special means are employed, the principal ones being (1) the Piling method, (2) the Drum method, (3) the Gobert or improved Poetsch sinking process, and (4) the Triger method.

#### PILING METHOD.

**1516.** When the quicksand or other soft material is near the surface, the method of piling shown in Fig. 452 is employed. This requires the shaft at the commencement of the soft material to be very large, especially where it must be carried to a considerable depth.

In such a case, a wooden curb of the size and shape of the opening is laid down in its true position. This may be made of oak about 9 inches wide and 6 inches thick. Outside of this, and all around it, piles from 6 inches to 9 inches wide and 3 inches thick are driven as deep as possible without breaking. After the first set of piles have been driven at the surface, excavation is started. When the excavation reaches a depth of about  $\frac{3}{4}$  the length of the piles, the work is squared up, and the second set of piles is driven within

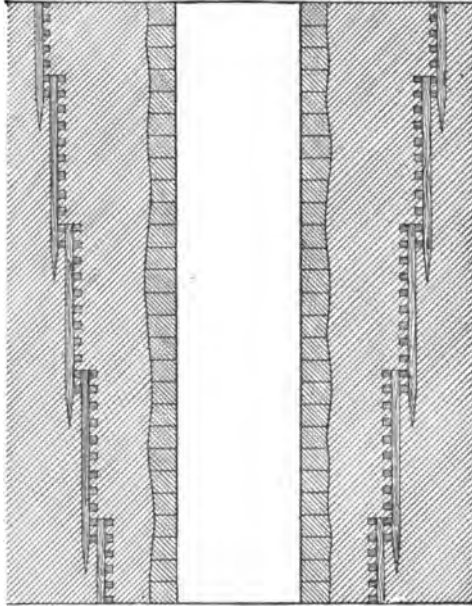

FIG. 452.

the first set as shown. This operation is continued until the quicksand is passed.

Assuming that the piles are shod with iron and are capable of being driven 15 feet deep, and that the curbs used in lining the shaft are 9 inches wide and the piles 3 inches wide, each course of piling will reduce the size of the opening ( $9' + 9' + 3' + 3'$ ) = 24 inches = 2 feet. With a pile 15 feet long a course will be required every 12 feet. The reduction of length or width in a thickness of 96 feet will be  $\frac{4}{3} \times 2 = 16$  feet; if the size of the shaft had to be 10 feet by 24 feet, to allow of a net size inside the timbers of 8 feet by 22 feet, it would have to be  $10 + 16 = 26$  feet, and  $24 + 16 = 40$  feet, giving 26 feet by 40 feet as the size at the top of the quicksand.

If we desired a shaft  $17\frac{1}{2}$  feet in diameter, then  $17\frac{1}{2} + 16 = 33\frac{1}{2}$  feet would be the diameter at the top of the quicksand.

**1517.** In order to keep the shaft the same width throughout, and that piling may be used when quicksand

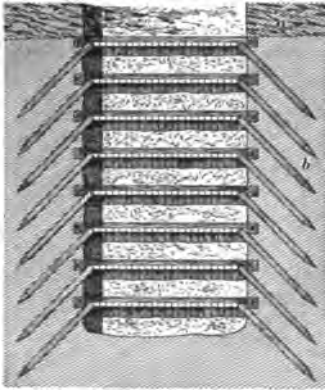

FIG. 458.

or other loose material is met at some depth from the surface, the style of piling shown in Fig. 453 is used. This system is applicable where the sand bed is very thick. The piles are driven at an angle of 40 degrees, or thereabouts, from the vertical on each side of the frame. The shaft is then deepened 2 or 3 feet below the first curb, or frame, and then another set of slanting piles is driven as before,

and so on till solid ground is reached. When the quicksand is very free, intermediate curbing sets may be necessary in addition to the piles.

When the piling has reached the bed-rock, a wedging

curb is laid and the walling is run up through the treacherous ground as expeditiously as possible. Where water is encountered under considerable pressure, the piling method is not suitable, as the sand will flow in as rapidly as it is excavated. To overcome this a great many methods have been devised; the most important one will be explained later.

**1518.** In cases where the quicksand is raised by the water pressure and boils upward into the excavation, work may be facilitated to such an extent that but little, if any, piling is required, a series of wells being driven, each of which is an ordinary driven-well tube having a suitable perforating point and strainer at its lower end. The wells are connected at their upper ends, by means of pipes and couplings, to a suitable pump, receiving the water through a sand box. In practice, the wells are driven about 8 feet apart, and about 8 or 10 wells are connected to a pump. In some cases, after pumping a few hours, the boiling springs of quicksand entirely cease, and the removal of the water so quiets and solidifies the quicksand that it can be freely handled with a shovel.

---

#### DRUM METHOD.

**1519.** Pile driving is most expensive, and is in many cases superseded by the so-called Drum method. In this system, a drum, either of wood or iron, of a size sufficiently large to allow the permanent walling to be inserted inside it, is sunk in the sand. The drum may be circular or rectangular, as desired.

**1520. Wooden Drum.**—A curb 12 inches to 18 inches wide and 6 inches deep is first laid down perfectly level on top of the bed to be sunk through, and a tier of masonry built upon it to a height of about 3 feet. (See Fig. 454.) A second curb is laid and connected to the first by iron tie-bolts, which are inserted before the masonry is built, so that the masonry may not be broken or deranged in any way. A water-tight lining of plank is placed behind it and



nailed to the curbs. When the ground is loose, the drum will sink into it by its own weight, but in beds more or

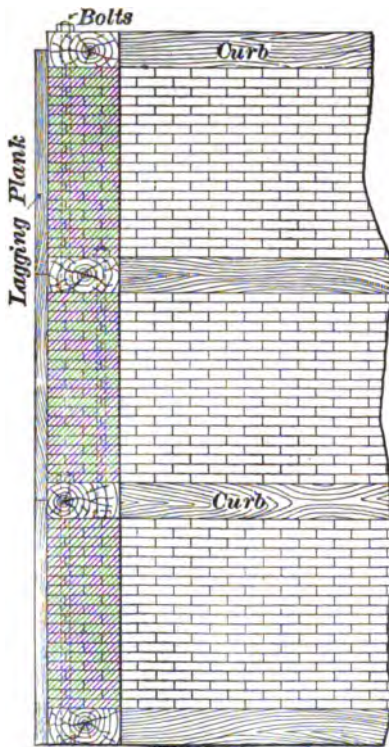

FIG. 454.

less coherent, cutters, or iron shoes, are attached to the bottom as in the iron drum to be described later.

In some cases, when exceptionally hard substances are met, it is not advisable to use cutters, because the tendency is to turn the cutter outward, which may rupture the drum. The drum should be kept perfectly level, the ground which offers the most resistance to its downward movement being removed.

At every 3 feet of advance a new curb is put on top of the last one and bolted as before, and so on to the end.

The greatest difficulty in this method is the tendency to "cant" to one side. The drum can not be relied upon to go down regularly. It will at times go rapidly, and at other times scarcely move, and if the material is a little softer on one side than on the other, it is inclined to cant that way. This is overcome by removing the ground from the harder side, or adding more weight to the drum on that side, or by doing both together.

The objection to wooden drums is that they require nearly as large an excavation as the piling method; for, in many cases, the whole structure sticks and can not be moved,

and the only remedy is to sink a second one, telescope fashion, inside the first.

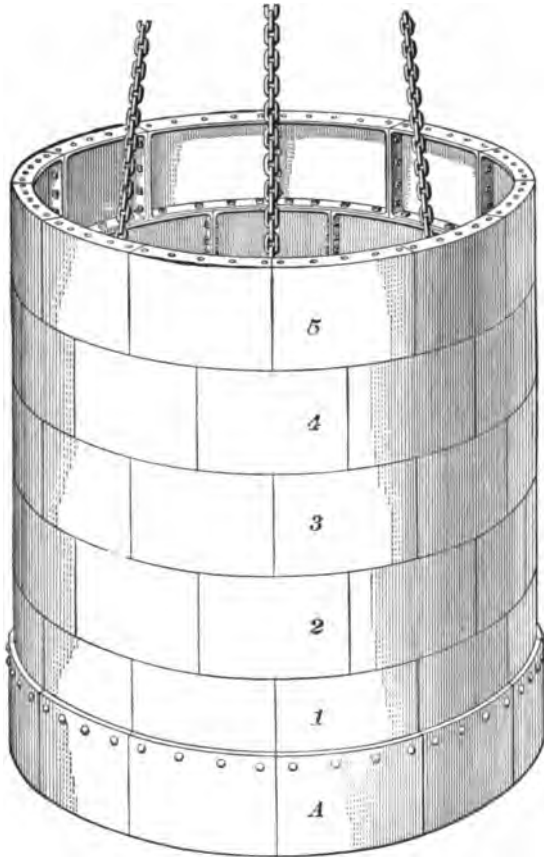

FIG. 455.

**1521. Iron Drums.**—These may be circular or rectangular, of cast iron or wrought iron. Although they sometimes have to be telescoped one within the other, the consumption of space is not nearly so great as with wooden drums. In the case of a circular drum, Fig. 455, the segments vary according to the diameter, ranging from 4 feet to 5 feet in length, and 2 feet in depth. They are strengthened by vertical and horizontal ribs on the inside. The

outside is perfectly smooth, and meets with little resistance in passing through the ground. The joints between the segments are filled with sheet lead, the segments being drawn together by bolts. The ribs are made broader where weights have to be used to sink the drum, and the cutter (Fig. 456) is attached to the bottom segment.

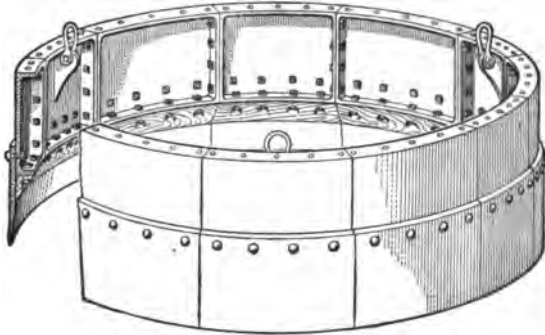

FIG. 456.

Sometimes the drum will sink too fast, and unevenly. To avoid this, the tubing is hung at three, four, or more points by chains and a lowering screw arrangement from transverse beams at the surface. The speed can in this manner be regulated at will, and when boulders, or any other obstructions, are met, they can be removed to prevent canting the drum.

**1522.** Cast-iron drums are not suitable for unequal strains, so in work where such strains are expected wrought-iron drums should be used.

Fig. 455 shows a drum with five tiers of segments above the cutter *A*, and Fig. 456 shows a perspective view of the cutter.

—————

**THE IMPROVED POETSCH, OR GOBERT FREEZING PROCESS.**

**1523.** When beds of quicksand are met at considerable depths below the surface, the foregoing methods are impracticable, and are replaced by an ingenious method known as Gobert's freezing process. In this system, tubes are forced through the water-bearing strata, and such a degree

of coldness is produced within the tubes that a cylinder of ice is formed around them. By placing the tubes in the proper position, an ice wall or dam may be formed around the line of shaft, or if sufficient time be given for the freezing, a solid mass of ice will form directly below the shaft, enabling the workmen to continue the sinking with unusual rapidity and a fair degree of safety.

**1524.** In Fig. 457 are shown a vertical and horizontal section of a shaft where this system is applied to a bed of quicksand about 30 feet thick and producing such a quantity of water that the pumps can readily keep it to the level of the bed. The vertical section *A* is taken on the line *D* and the horizontal section *B* on the line *E F*. Large wrought-iron tubes *p*, about 8 inches in diameter, are driven into the quicksand at such an angle that the permanent walling can be put in without removing them. These tubes are connected together at the top by cast-iron fittings *c*, and provided at the bottom with a circular shoe *s* to facilitate the passage of the tubes through the quicksand. They are also closed at the bottom, after being driven to their permanent position, by a lead plug *n* and several alternate layers of cement and pitch *l*. Within each tube *p* is placed a small tube *t*, having a helicoidal or serpentine shape, and provided at the top with a valve *v* to regulate the inflow of the liquid which produces the lowering in temperature. The tubes *t* are also connected together above the valves *v*.

**1525.** When the system is properly connected, anhydrous liquid ammonia is forced from the refrigerating plant at the surface down the tube *q* into the small serpentine tubes *t*, along which it is allowed to escape into the tubes *p* through small orifices *h* placed in the valley-beds of these tubes. The liquid continuously flows in thin streams through the orifices, vaporizes, and, consequently, takes up a great deal of heat from the surrounding strata, causing them to freeze. This vapor is forced through the tube *e* to the refrigerator, where it is deprived of its heat and again compressed into a liquid ready to return through the tube *q*.

The pressure within the tubes  $p$  is almost invariably less

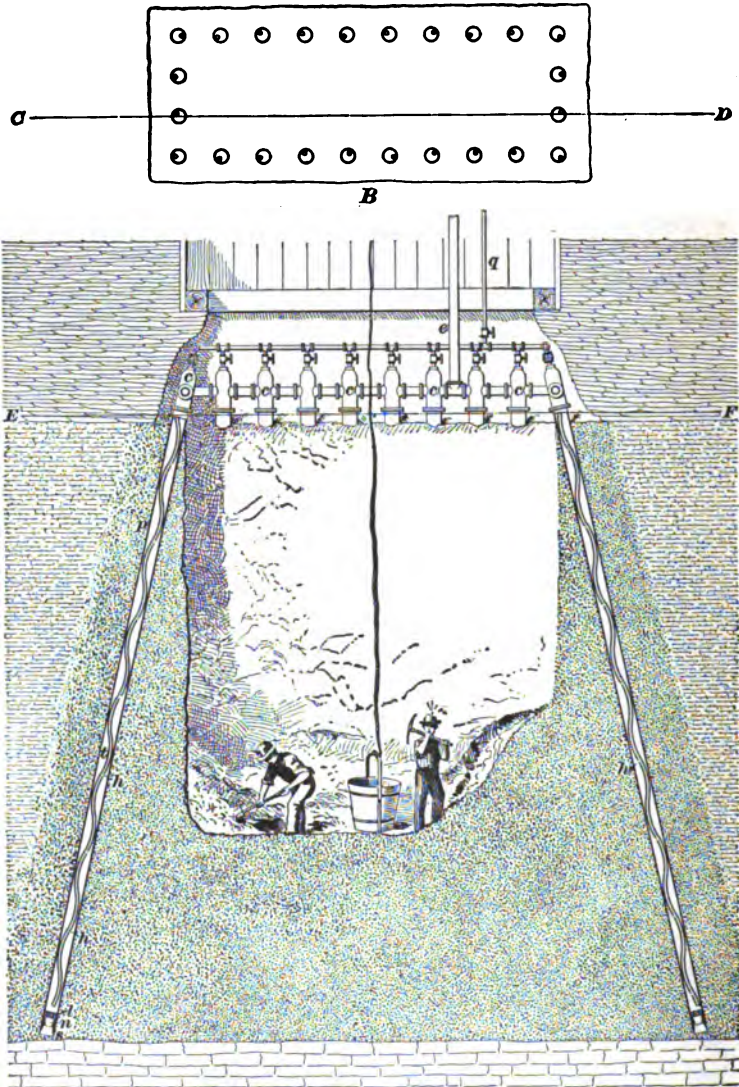

**A**  
FIG. 457.

than the external pressure, thereby preventing any possibility of the liquid flowing out in case of a break in any of

the tubes. Should any of the liquid escape, an uncongealable mass would be formed around the tube, resulting in serious difficulties. It is best to have the small tubes *t* touch the sides of the tubes *p*, so that the heat will be readily conducted from the strata to the liquid.

**1526.** When beds of quicksand which produce enormous quantities of water under great pressure are met, the shaft is allowed to fill up and long tubes are put down through the quicksand from the surface along the sides of the shaft. In such a case no pumping is required while the freezing goes on at the bottom of the shaft. This result of freezing the strata at the bottom of the shaft only is accomplished by simply providing the tubes *t* with orifices near the bottom, or for a distance along the lower ends of the tubes equal to the thickness of the strata to be frozen.

**1527.** It is often advantageous to have the freezing begin at the top of a thick bed of quicksand and proceed downwards. This can be accomplished by a small supply of the liquid, which will completely vaporize before it reaches the lower ends of the tubes *t*. When this is done, the top freezes and, therefore, will not give up heat readily; this causes the liquid to go down further to become vaporized, thus carrying the freezing gradually to the bottom of the tubes. When the tubes are put down from the top of the shaft, they are made up in sections joined together by means of an internal jacket so as to keep the outer surface of the tubes uniform, and each tube is closed before being put down. While sinking, the verticality of the tubes can be tested either by the thermometer or by driving short horizontal headways from the shaft into the pipes. The system is applicable to both rectangular and circular shafts.

---

**TRIGER'S METHOD OF SINKING.**

**1528.** Triger's method of sinking through running and wet surface ground and the construction and mode of action of the Triger tube are very interesting. By reference to Fig. 458, it will be seen that what is called the tube is built up of three short cylinders, joined by their inside horizontal flanges,

the joints being made air-tight and free from outside obstructions. The weights *L* force the tube into the water-bearing strata.

The tube is divided into three chambers by two decks,

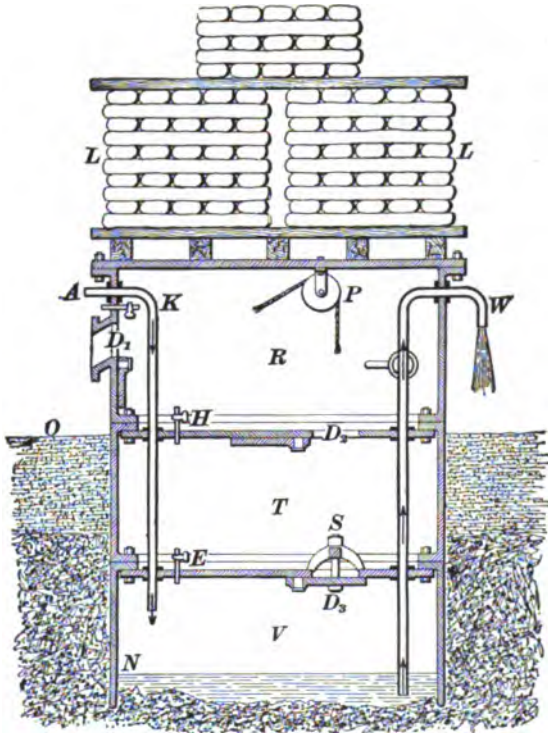

FIG. 458.

and entrances into the middle and bottom chambers are provided through the doors or valves  $D_1$  and  $D_2$ . The pressure of the compressed air always exceeds the pressure due to the water head. Let  $O$  be the surface water level, and  $N$  the water level within the tube. If  $ON = 50$  feet, it will require a pressure due to a water head of 70 feet to keep the ground within the tube practically free from water. In the figure, the valves  $D_1$  and  $D_2$  are open, and the valve  $D_3$  is closed.

The compressed air enters the chamber  $V$  by the pipe  $A$ . The water within the tube is then pressed out through the pipe  $W$ . The mode of entering and leaving the chambers is interesting, and is as follows: It seldom (or never) happens that the valves  $D_2$  and  $D_1$  are open together when  $D_2$  is closed, it being so arranged in the figure only to make the details plain.

Suppose it is necessary for gravel and stones to be lifted from  $V$  into  $T$ , or for the workman in  $V$  to pass up into  $T$ . The valve  $D_2$  is then closed by a workman in the middle chamber, who also opens the small tap  $E$ , and in a short time the pressure in  $T$  is equal to the pressure in  $V$ . The workman in  $V$  then opens the valve  $D_2$ , when he can pass into the middle chamber  $T$ ; or stones and dirt can pass from  $V$  into  $T$ . If a change of workmen is to take place, one passes into  $V$ , and closes  $D_2$ ; the man in the middle chamber is then relieved by the tap  $H$  being opened;  $D_2$  is then opened, and the two men change again. The man passing into  $T$  shuts  $D_2$ , and opens  $E$  to equalize the pressure between  $T$  and  $V$ , and the man in  $R$  opens  $K$  to equalize the pressure with that of the atmosphere, when he can open  $D_1$  either to discharge dirt or pass out himself. The pulley  $P$  is used in raising or lowering men or material through the valves  $D_2$  and  $D_1$ .

After a bed of rock is reached by this process, the inside of the cylinder is lined with brick to prevent damage to flanges which might occur in working the shaft for mining purposes.

**1529.** The depth which can be reached by this method is limited; for the pressure of water outside the cylinder increases with the depth, and a higher pressure of air must be used in the lower compartment to stop the inflow of water. A point is soon reached at which sinkers can not work. As much as 121 feet of quicksand have been passed through by this method, the greatest atmospheric pressure being about 41 pounds per square inch.

There are other pneumatic systems, but they are all subject



to the drawback that men can not work when the pressure exceeds 45 pounds per square inch above the ordinary pressure, and even at less pressure great care is necessary to avoid ill effects on the sinkers.

**SINKING THROUGH HEAVY FEEDERS OF WATER.**

**1530.** The principal methods of sinking through heavy feeders of water are the Kind-Chaudron and the Lippman.

**1531. The Kind-Chaudron System.**—This is applicable only to circular shafts, and is undoubtedly the best where heavy feeders of water must be contended with.

Four or five men stand on a working floor 16 feet below the surface, to which depth the diameter is from three to four feet more than the size of the shaft below. From this point, the shaft is carried down by the ordinary method to the water level, and walled up with brick or wood. The shaft stands full of water and unlined until the boring has reached solid rock below the water-bearing strata, when the tubing is put in place.

**1532.** The excavation is effected in two successive stages. At first, a cylindrical hole of about 4 feet 6 inches or 5 feet in diameter is bored, which is usually kept at least 35 feet further advanced than the full size shaft. This hole is enlarged to the full size of the shaft by the second or third operation.

The manner of cutting the excavation is the same in the first and second stages; the removal of the débris in each stage is accomplished differently.

In each case, the cutting tool *T*, *T*, Fig. 459, called a **trepan**, consists essentially of a horizontal bar of wrought iron, to the under surface of which are attached steel teeth, so placed that as the bar is rotated around the central axis of the shaft, each tooth, in falling with the bar through the requisite length of the stroke, generally 10 inches to 20 inches, cuts for itself an annular portion of the bottom of the shaft. The trepans, both large and small (which, of course, work at different times) are lifted and turned by the same rods, made of pine 8 inches square, about 59 feet long, and

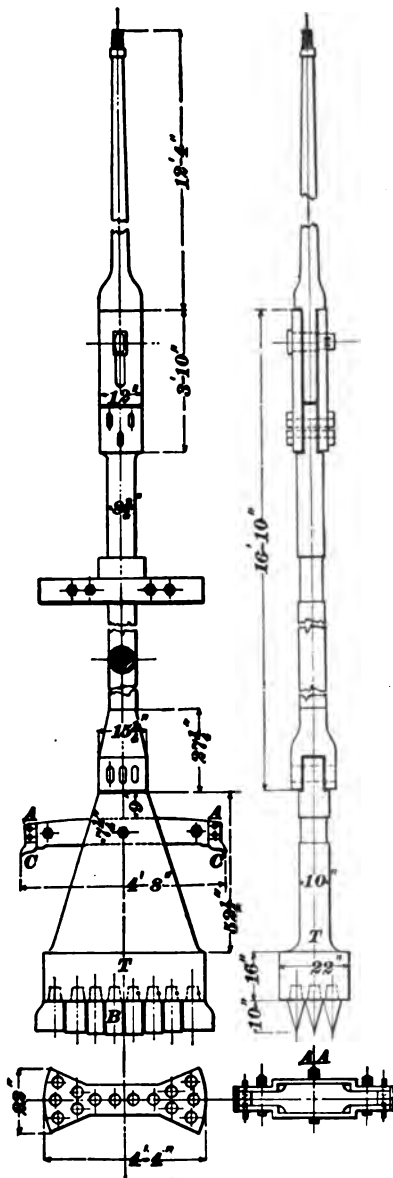

FIG. 459.

connected by a male and female screw. The elasticity of the wood with its buoyancy in the water gives them a great advantage over iron rods.

**1533.** The stroke of the cutting tool is effected by means of a simple lever at the surface, to one end of which the rods are attached by a strong flat chain, while near the other end the lever may be connected directly to the piston rod of a steam cylinder, as in a Cornish pumping engine. The length of this lever should be about 24 feet, and the fulcrum so placed that the ratio of length will give the desired stroke to the cutting tool. Beneath the suspension chain is a lengthening screw, and below that a very strong swivel, by means of which the rotating movement is given to the rods and cutting tool.

The upper piece of rod has eyes for the insertion of crossbars by which the actual turn is given at each stroke by the workmen near the top of the shaft. The smaller trepan, shown in

Fig. 459, is differently constructed, according to the nature of the ground it is intended to cut. When intended for cutting soft material, the bar in which the teeth are attached is suspended by a fork of wrought iron; but where hard rock is to be cut, the bar is to be forged in a single piece and weighs from 18,000 to 22,400 pounds. The steel teeth fit into sockets in the main bar, and are additionally secured by a pin, which is readily driven out when the teeth must be sharpened or renewed. The instrument shown in Fig. 459 is capable of advancing 8 feet per day in ordinary ground. The arm *A A* is for the purpose of steadying the motion of the machine and is slightly larger in diameter than the lower part *B*. The teeth *C, C* on the arm *A A* widen the hole slightly and trim off the edges.

**1534.** When the cutter or trepan has done work for some hours, usually at the rate of 9 or 10 strokes per minute, sometimes at about 20 strokes per minute, it is raised by a small hoisting engine, with a flat hemp rope  $14\frac{1}{2}$  inches wide by  $2\frac{3}{8}$  inches thick, and by the successive unscrewing of rods. The hole is then cleared by means of a sheet-iron cylinder, about 6 feet in length, with two valves in the bottom, which is lowered and raised by the rods. On being worked up and down and turned in the same manner as the cutting tool, the débris is drawn into it; and when it has sunk to its depth in the loose stuff, it is raised, the valves close, and the material is brought to the surface.

**1535.** The larger cutter, or trepan, Fig. 460, which weighs about 36,000 to 49,000 pounds, is similarly formed of a wrought-iron bar having teeth attached for that portion of its length which exceeds the diameter of the smaller excavation. It is guided below by a cradle or iron bar *C*, which fits closely within the smaller excavation.

The teeth are so formed and set that they always cut the bottom of this second stage into a sloping surface, so as to allow the fragments to roll into the smaller shaft, where they are caught in a sheet-iron bucket which has been previously lowered into it. The rate of progress in ordinary ground,

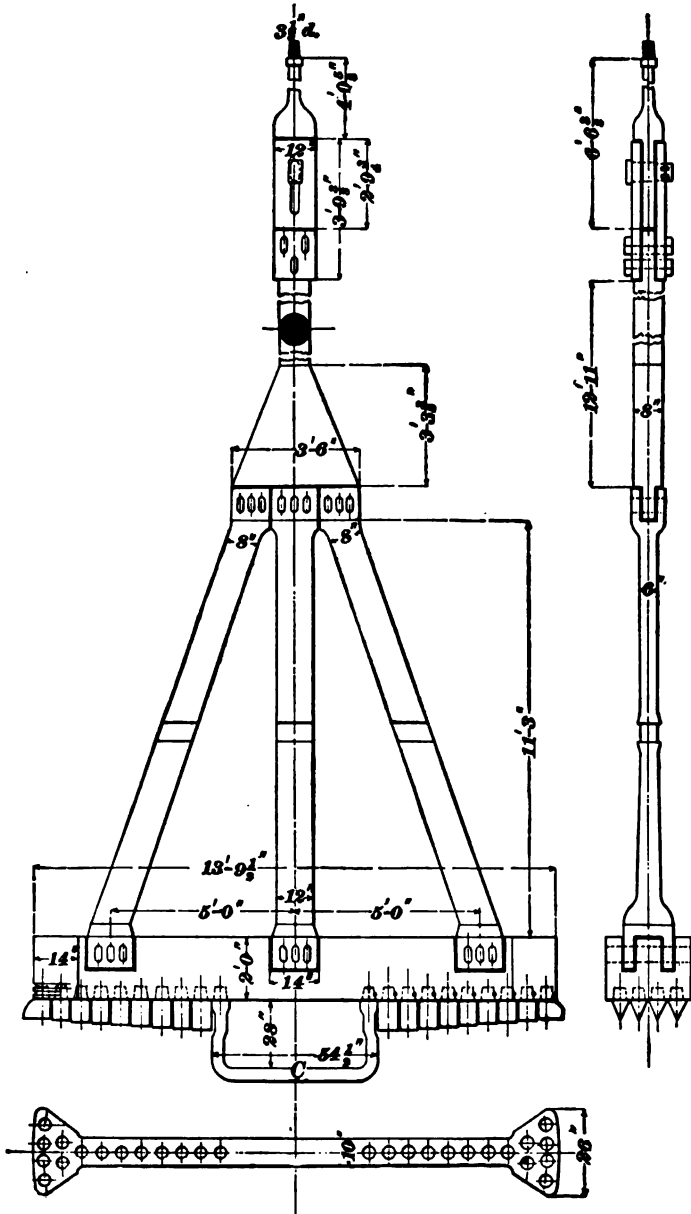

FIG. 400.

when all is going well, is about 40 inches per day; but in hard rock the rate will not exceed 10 inches per day.

**1536.** In order to obviate the tremendous vibration which would be imparted to the rods by tools of this great weight, a special arrangement is necessary in order that the heavy rod and cutting tool, which together are 36 feet long, may be "free falling," the balance of the rods being used simply to raise the cutter to the desired height of stroke. To accomplish this, a slide piece of great strength is used in a manner resembling the "jars" in the American rope method of boring.

The guides of the smaller trepan are set at right angles and formed of two strong iron bars. In the case of the larger trepan, one cross-piece only is rigid; the other one, at right angles to it, is hinged on both sides of the main rod in such a way as to be lowered or raised during the shifting of the tools. These folding arms, when required to be used, are brought into position when the tool is ready for work. The guide then forms a cross, through the central opening of which the rod of the tool slides freely up and down.

Figs. 459 and 460 show the dimensions of the tools for boring a shaft 14 feet in diameter.

**1537.** The most remarkable part of the operation is the fixing of the tubing, Fig. 461, without the use of pumping engines, in such a manner that it securely dams back the water in the measures sunk through. The lower ring of the tubing is, like all the upper portion, cast in a single piece. Its bottom flange *A*, which comes to rest on the bed or seat cut in water-tight ground, is turned outwards, and its upper flange *B* inwards. Upon the lower flange, and all around the ring, a wall of well-picked moss *C* is tightly packed. This moss is enclosed in network while being lowered to position. To aid in the forcing of the moss against the side of the shaft, small sheet-iron springs *D* are placed above and below, as seen in Fig. 461, which have the effect of giving the pressure a definite direction. The next ring *E*, which is large enough to slide down on the outside

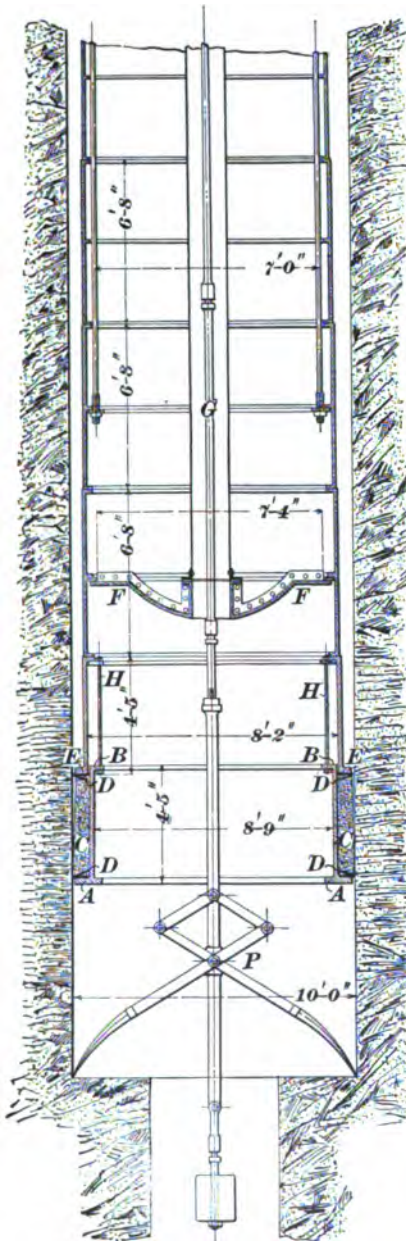

FIG. 461.

of the bottom piece, rests on the moss cushion by a flange also turned outwards. As soon as the moss is pressed down by the weight of the ring *E*, the ordinary rings of the tubing are built upon it, as before, and their weight continues to compress the moss until it is practically solid. Each flange is planed, and between them a ring of sheet lead  $\frac{1}{8}$  inch thick is laid, which, after screwing up the bolts, is beaten in on both sides with hammer and chisel.

The tubing is of extra thickness, and each ring is generally made  $4\frac{1}{2}$  feet to 5 feet high. The lower ring is  $2\frac{3}{8}$  inches thick, and the upper ones are made gradually lighter. In order to facilitate the gradual lowering of this enormous weight by the six rods and screws used for this purpose, a diaphragm or false bottom *F* is attached by screw bolts near the bottom of the tubing, which causes it to float on the water. A central equilibrium tube *G* passes up

the shaft, and stop-cocks, placed at intervals, allow water to flow into the middle of the tubbing in such a quantity as will help its descent. In this way only a small portion of the weight of the tubbing is carried by the suspension rods and screws.

When at length the moss box, hanging by light rods *H* from the flange of the upper ring, comes to occupy its position on the seat or bed, the weight of the tubbing above begins to bear on the moss and squeezes it down and against the sides in such a manner as to form a thoroughly water-tight joint. For additional security, the annular space between the tubbing and the sides of the shaft is filled with concrete, which is allowed to consolidate before the water is drawn out of the shaft.

Much depends upon the perfection with which the seat of the moss box is cut and smoothed. For the purpose of ensuring its proper condition, a gigantic pair of pincers *P*, Fig. 461, with arms on the principle of a lazy-tongs, is lowered with and underneath the whole of the tubbing, having a rod passing up through the central or equilibrium pipe. The end of this tool can, by working the rod up and down, be made to expand to the full diameter of the shaft, and brought together so closely as to pick up fragments of stone or iron which may be lying on the bed of the shaft, and then in its contracted form may be passed out of the way into the smaller central shaft.

**1538.** After the cement has set, the water is pumped out of the pit, the false bottom is removed by unscrewing the bolts which attach it to a flange, the moss box foundation is examined, and to make everything safe, a lower seating is cut a few feet deeper, a wedging curb put in by hand, in segments, and a length or two of tubbing built up to the moss box, and securely wedged against it. The shaft is then free from water and ready for further sinking by the ordinary method.

By this method,

1. No pumping engine is required while sinking.

2. The water pressure in the shaft to a great degree prevents the inflow of quicksand or other soft material.

**1539. The Lippman System.**—In this system the hole is bored any required size from the beginning by a large trepan having a cutting tool bifurcated at both ends, or shaped like a Y at each end. This form of trepan, shown in Fig. 462, is adopted in order that the blows near the circumference will be approximately as close as those near the center. In this

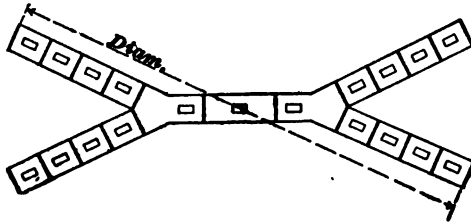

FIG. 462.

system, the engine gives motion to the boring lever by means of an endless chain and an eccentric, which prevents all shock. For removing the débris, an iron box divided into three compartments, each compartment having nine holes closed by valves opening inwards, is operated just as is the sheet-iron cylinder used in connection with Fig. 459. This iron box must generally be filled twice before boring can be resumed.

The sides of the shaft are secured in a similar manner to that employed in the Kind-Chaudron system.

#### THE LONG HOLE SYSTEM.

**1540.** This process consists of drilling holes from 100 to 300 feet deep, or more, and close enough to each other (3 to 4 feet apart) to be used for blasting. When the drills are taken out of the holes, the holes are filled up with sand. The sinkers then usually drill sumping holes in the center and blast out the rock. They then remove 3 or 4 feet of sand from the long holes. The inner group of long holes is always fired first, and the outside rows afterwards. The outside holes generally square the shaft nicely, so that little dressing is required. When the bottoms of the holes are reached, the drills are again put at work.



This method has been successfully carried out in the Norwegian shaft near Pottsville, Pa., which is nearly 1,600 feet deep, and at the Ellangowan shaft near Shenandoah, Pa. The drill holes were put down in stages of 200 to 300 feet by the diamond drill. The great objection to this system is that in rocks of varying hardness long holes are liable to turn from the vertical, and those nearest the side may fall outside of the line of the shaft.

### DEEPENING SHAFTS.

**1541.** When there is plenty of room, so that a compartment of the shaft can be set aside for hoisting the débris, or where the regular hoistways can be used by sinkers at night, deepening a shaft is no difficult matter. If, however, the hoisting of coal goes on incessantly in a narrow shaft, then a rock slope must be driven to a point directly under the shaft. This slope must be started at such a distance from the shaft and driven at such an angle

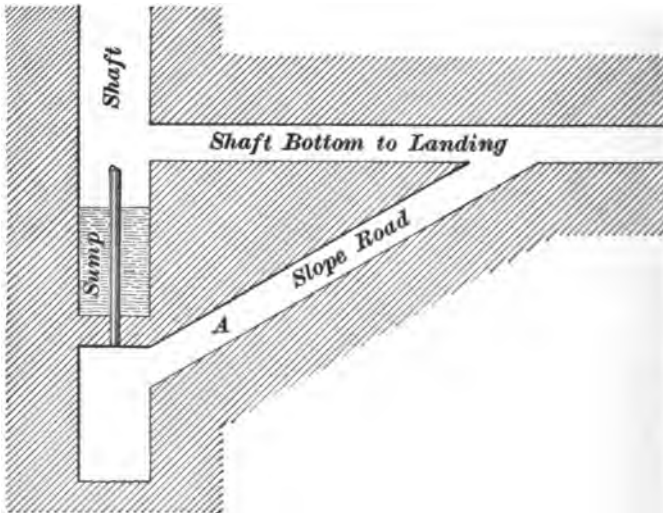

FIG. 463.

that, when it is directly under the shaft, the strata between the slope and the bottom of the sump in the shaft will be

thick enough to ensure that the water will not pass through it. Then, from the foot of this stone slope, the sinking of the shaft may begin. (See Fig. 463.)

In this case, a hoisting engine or a windlass must be used in the rock slope to get the cars out of the shaft and up the incline *A*; or a bore hole may be put down in the shaft bottom and a pipe inserted with cement. The top of the pipe should be above the water level in the sump. Through this pipe, the hoisting rope is passed to an engine at the surface by carrying the rope up the side of the shaft.

**1542.** Where one compartment can be used for hoisting the *débris*, the shaft is carried down narrow to a depth that will ensure strength in the rock to maintain itself and hold the water; then the full length and width is carried down. The sump in the old shaft bottom is maintained by putting in a secure dam to keep the water confined, so that it will not pass into the sinking shaft. Sometimes, when the depth is not very great, the whole width is carried down, and the water is all pumped to the surface from the point of sinking. In this case, the bottom of the landing, from which the coal is hoisted, is made of a close framework strong enough to protect the sinkers while working.

---

#### WIDENING SHAFTS.

**1543.** This is sometimes necessary, but it is practised so little that information on the methods employed is scarce. It is an awkward and costly operation, and must be done when the shaft is not in use. It is usual to place a series of buntons below each other in such a position that the cages in passing up and down will not strike them. When the hoisting is discontinued, planks are laid on these buntons, making a secure scaffold on which the men stand to remove the strata, and, if necessary, put in new timbers. The work, more especially in soft strata, seems to give best results when the start is made at the top of the shaft, and the work carried downwards.

**CONDUCTORS, GUIDES, OR SLIDES.****USE OF GUIDES.**

**1544.** These three names are different terms applied to the arrangement in shafts for preventing extreme oscillation or vibration of the moving cages, so that two or more of them can run in opposite directions in a comparatively narrow place without colliding with each other. They also keep the cages from striking the sides or ends of the shaft. There are various kinds and arrangements of conductors, either rigid, of iron or wood, or flexible, of strong wire rope.

When there are column pipes in the shaft, and consequently many buntons and horsetrees to which the rigid guides can be secured, such guides will give the best results, and it is only under these conditions that they should be employed.

**WOODEN GUIDES.**

**1545.** When wooden guides are used, they are placed one on each side of the cage and are attached to the buntons in a vertical line by countersunk bolts or wood screws. They are made of pitch pine, the dimensions varying from 4 inches by 4 inches to 6 inches by 8 inches. The manner of splicing or joining the lengths has already been shown.

The utmost care must be observed in splicing, for even a small projection may catch the shoe of the cage and result in the destruction of some part.

**1546. Point Rods.**—Point rods are necessary only in exceptional conditions, such as when the buntons and other timbers are placed so that it is desirable to have the guides at the ends of the cage, and the cars are caged from the same direction. Slippers, or shoes, when point rods must be used, are placed on all four sides of the cage. When the cage is in any part of the shaft, excepting top and bottom, the shoes at the ends are in contact with the guides at the ends of the shaft. The end guides are discontinued near the top and bottom, and are replaced by the point rods, which engage with the slippers on the sides of the cage before the

end guides are discontinued. If the guides are rods, they are pointed, or if of channel iron, they are belled out at their termination, so that there will be no doubt about the shoes engaging the guides.

Sometimes, the side guides and slippers are replaced by angle iron guides, which are so placed that they will engage the four corners of the cage; these guides are also belled out.

---

#### IRON GUIDES.

**1547.** These may consist of channel iron, structural T iron, round iron, or T-iron rails. The first two—channel iron and structural T iron—are held in position by bolts or wood screws in much the same manner as the wooden guides. The holes in the iron are countersunk so that the head of the bolt or screw can not by any means protrude. It is almost impossible to make the proper arrangement for expansion and contraction in such guides, which is a strong objection to their use. Expansion and contraction are sometimes provided for by leaving a small space between the ends of the guides at each joint. The slippers are made of a pattern that will suit the particular arrangement that is used.

**1548. Round Iron Guides.**—These consist of bars of 1-inch or  $1\frac{1}{4}$ -inch round iron extending from the top to the bottom of the shaft. They are held in position by being secured at the top and bottom on heavy cross-timbers, and are kept taut by turnbuckles—a right and left screw—located at a place convenient for observation and manipulation either at the surface or at the bottom of the shaft. Or the rods may pass through a hole in the bottom timber, and weights be suspended to them heavy enough to keep them taut. The latter plan, in many cases, is the better one, inasmuch as expansion and contraction are provided for.

**1549. T-Iron Rail Guides.**—These are used to get the rigidity of wood and avoid rapid wear. They are quite expensive; therefore, their use is the exception and not the rule. The flanges of the rail for this purpose are usually made broader than the ordinary construction, and are fitted

into chairs made fast on the buntions and on the sides of the shaft timbers. The rails should be fastened together by fish-plates attached to the back of the rail. In such a case

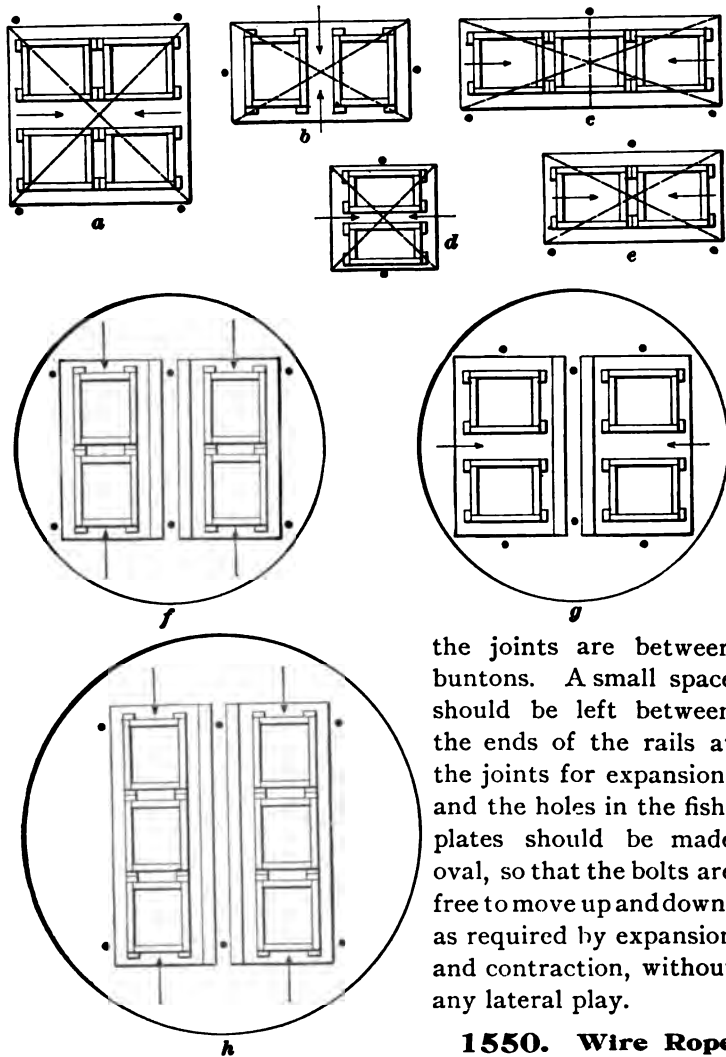

FIG. 464.

the joints are between buntions. A small space should be left between the ends of the rails at the joints for expansion, and the holes in the fish-plates should be made oval, so that the bolts are free to move up and down, as required by expansion and contraction, without any lateral play.

### 1550. Wire Rope Guides.

— Where wire rope conductors are used in deep shafts, the clearance must

be more than with rigid conductors, because of the vibration that is set up in the guide ropes by the running cages.

Fig. 464 shows the various arrangements for wire rope guides for the different arrangements of the cages.

At *a* is shown a cage with four cars and four wire conductors; at *b* is shown a cage with two cars and two conductors; at *c* is shown a cage with three cars and three conductors; at *d* is shown a cage with two cars and two conductors; at *e* is shown a cage with two cars and three conductors; at *f* is shown two cages with two cars each and two conductors each, and flat rope or safety conductors between. Two conductors, both on one side of the cage, are used, and between the cages, and unconnected to either of them, two other ropes are suspended. These latter ropes are often flat (not always), and at the passing point are lined or covered with steel or copper strips which prevent any possibility of the cages colliding when the clearance is very little. At *g* is shown two cages with two conductors each and two cars each; at *h* is shown two cages with three cars each and two conductors each.

The arrows show the direction in which the cars are run on to the cage, and the dots show the position of the guides. The dotted lines show the position of the cage chains.

**1551.** Wire rope conductors, like T-rail and other iron guides already mentioned, are subject to expansion and contraction. This is provided for in the following manner: Each conductor is made secure at the top of the head-frame with two or more wrought-iron clamps. These clamps grip the conductor and rest upon timbers of sufficient strength to safely carry the greatest weight necessary to keep the conductors taut. Care must be exercised in fitting the clamps nicely to the guides; otherwise, instead of holding the conductors firmly, the clamps may actually nip and tend to break them.

At the lower end, in the sump, heavy weights are placed upon clamps, one or two pairs gripping the conductors. The weight varies according to the depth, but a fair rule is 2,240 pounds for each 600 feet of the depth.

The rope should not, as in the case of the round iron guides, run through a hole in a bottom sill, but the bottom sill should be so arranged that heavy staples may be driven into it over the rope. This avoids corrosion of the rope by water and dirt settling around the guides in the timber. It also permits the rope to be examined there as well as in other parts of its length. Care must be taken to see that the weights always hang freely on the conductors. These ropes should be thoroughly examined once each week.

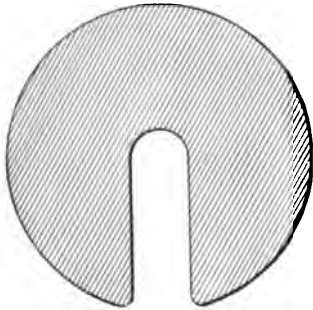

FIG. 465.

It is not possible at all times to put on the exact weight that will be required; consequently, there should be a number of extra circular weights, Fig. 465, with a slot from the center to the circumference in each, so that they can be slipped on top of the weights already hung on the rope.

---

## SLOPES.

---

### SLOPE SINKING AND TIMBERING.

**1552.** In mining, the term **slope** is applied to an inclined gallery or roadway driven through the measures to a seam of coal; or, where the seam is pitching, a passageway driven in the coal towards the dip is also termed a slope.

Where a seam has a dip of  $20^\circ$  or more, and is brought close to the surface by an anticlinal axis, a slope, dipping the same as the coal, may be started from the surface, and when the seam is reached may be continued to the desired depth in the coal. If a seam is comparatively flat and near the surface at the desired place of opening, it may be opened up by a **shaft** or **slope**, depending largely upon the individual choice of the engineer in charge.

A slope and an air course are generally sunk side by side in the coal; but, where the slope passes through the overlying strata, a shaft is sunk near by to serve as an airway.

**1553.** In commencing a slope, the ground is excavated in an open cut, precisely as a railroad cut is made, the sides being trimmed back to the angle of repose, or made perpendicular and supported by crib work. The excavated ground is thrown out by hand or removed by wheelbarrows. When the face of the cutting has a greater vertical height than the total height of the timber to be used, the sinking of the slope is commenced in the following manner:

Sufficient room is first excavated for a set of timbers in advance of the one set up where the open cut was discontinued. Where the ground is friable, as it frequently is at

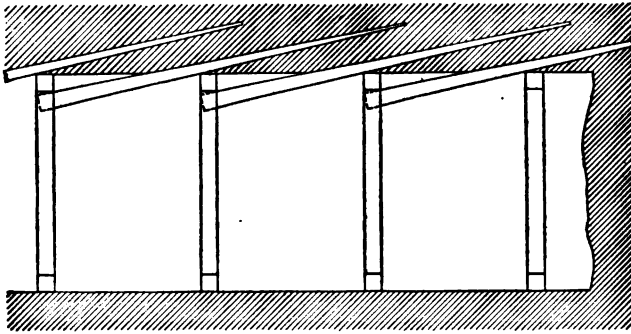

FIG. 466.

shallow depths, lagging of timber (usually 3-inch or 4-inch plank on top, and 2-inch or 3-inch plank on the sides in well-finished work) is securely placed. The lagging is made flush with the front of the first set of timbers, but on each set thereafter, it reaches from center to center. Sometimes, the ground is so soft that **forepiling**, or piling driven in the roof in advance of each set of timbers, is employed (see Fig. 466), so that the timbers can be put in without removing an unnecessary amount of material.

**1554.** Frequently, the overhead lagging is put up by cutting a trench from the top to the bottom of the face of the slope, from 12 inches to 18 inches wide, the one end of the lagging board resting on the last set of timbers, and the forward end resting on a temporary prop of suitable length.



When this prop is secured in place, another slice is cut on either side of this single top lagging and another plank put in, and so on till all the top lagging is in, with the forward ends resting on props and the back ends on the last set of timbers. The temporary props should slant inwards towards the face at the bottom, so that the "foot" or mud-sill can be put in without disturbing them. The mud-sill is now put in place, and the set of timbers put up sloping backwards on the head; the set is now driven forwards to the props, which are removed, and the complete set of timbers is carefully driven forwards and lined in place.

When necessary, the sides may be secured in the same manner as the top is secured in Fig. 466.

The distance these sets of timber shall be apart is, of course, governed by the nature of the roof, and may range from "skin to skin" (Fig. 472) to 8 feet apart.

**1555.** The dimensions of a slope depend upon the number of tracks to be laid in it and the size of the mine car. In some districts, the average capacity of the cars ranges from 2,000 to 3,000 pounds, and they measure about 4 feet in width, while in other districts cars carrying from

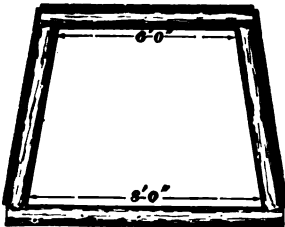

FIG. 467.

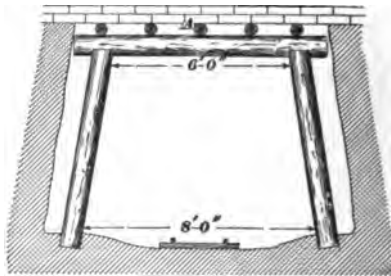

FIG. 468.

2 tons to 4 tons are used, measuring as much as 5 feet in width.

In short, with single track slopes, where the cars do not measure more than 4 feet in width, a style of timbering such as is shown in Fig. 467 may be used.

Fig. 468 shows how timber framework, after being placed in position, can be firmly wedged against the roof with lagging *A*.

**1556.** Where the legs are stood without a mud-sill or foot-sill, each leg must be measured. The foot-hole having been dug, a light stick of wood is nailed from the last two sets of timbers at the proper angle to project the proper distance, and the length of the leg required is measured from the point of this stick to the bottom of the hole by a sliding measure of two thin strips of wood which act as a measuring rule. This requires care, or the timber will get out of line, or some will be higher than others. With round timber, small differences are not easily seen, but with square timber any irregularity will be noticed quickly.

**1557.** In slopes where the output is large, a double track is usually adopted. In such cases, the double track may be laid with three rails and a "turnout," or passing place, at the middle of the plane, or it may consist of two distinct and continuous tracks throughout the length of the plane. The former plan has the advantage of minimizing the width of the slope, but is open to several objections, the principal of which are the liability of collision of the ascending and descending trips, or trains, at the passing place, if there is more than one landing, and the wear and tear of the rope, which, by reason of the lateral movement due to the travel of the coil on the face of the drum, must at certain places chafe against the cars, the rope on the one side being impelled against the cars attached to the opposite rope. In every case where double tracks are needed, it is preferable to lay down two independent and continuous tracks.

**1558.** Where a double track is in operation, the slope must be from 12 feet to 24 feet wide in the clear, depending on the size of the car to be used and the number of compartments in the slope. It is rare in a slope of such width that the roof or top is firm enough to stand without the aid of timber, which frequently must be placed at close intervals. Fig. 469 shows, in section, the timbering of a double track slope. The prop placed under the center is fixed between the two roads, and the collar and legs are closely

lagged all around so as to prevent any fall or slip of the roof or sides. The timber generally consists of sticks from

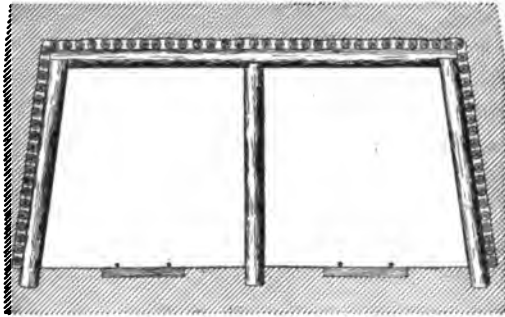

FIG. 469.

9 inches to 14 inches in diameter. In many instances, more substantial timbering is adopted, and beams ten inches to fifteen inches square are used instead of the round collars and

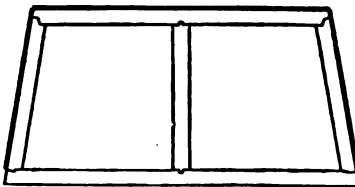

FIG. 470.

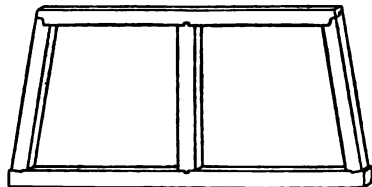

FIG. 471.

legs, and they are lagged with planking instead of poles, as described. This form of timbering is shown in Figs. 470 and 471.

Fig. 472 shows the "skin to skin" method of timbering, so called because the sets of timber touch each other. It is used in soft ground where the pressure is very great. The figure shows round timber, but square timber is sometimes used in this manner.

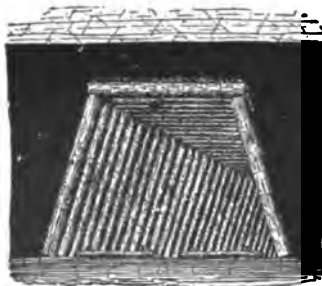

FIG. 472.

**1559.** Fig. 473 shows the double notch in the mud or foot-sill of Fig. 471. The leg *b* is placed to show the check which rests on the sill *a* to prevent slipping. The step in the box prevents the leg from slipping

down off the sill, and the check on the front holds down the top

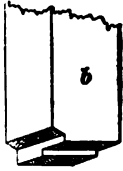

FIG. 473.

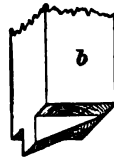

FIG. 474.

surface of the sill when the weight sinks the leg tight into it.

Figs. 474 and 475 show the groove in the sill *a* and the

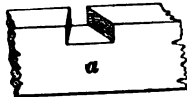

FIG. 475.

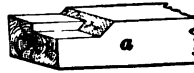

FIG. 476.

tongue on the leg *b* to prevent the leg from being driven down the pitch.

Fig. 476 shows a view of the leg *b*, and represents the collar *a* turned up, showing the double notch to prevent it slipping down the pitch.

Figs. 477 and 478 show another style of joining by tenon

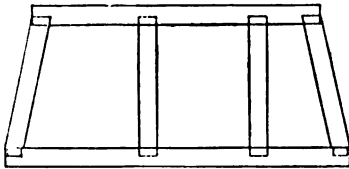

FIG. 477.

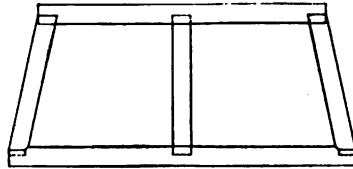

FIG. 478.

and mortise, but the great objection to it lies in the fact that the legs are not easily removed when retimbering is desirable.

Figs. 479 and 480 show the manner the mortises and tenons in Figs. 477 and 478 are made.

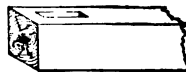
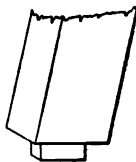

FIG. 479.

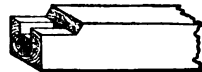
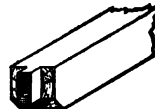

FIG. 480.

**1560.** Fig. 481 shows the provision made to keep the track in place, that is, to prevent it from slipping down the

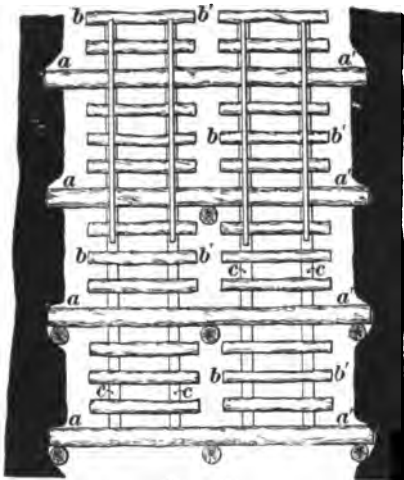

FIG. 481.

pitch in the slope. The long ties are shown resting against the legs in the lower portion of the figure; the middle shows the arrangement of the roadbed when only a center prop is used, and the upper part of the figure shows the arrangement when no timber is used; *a a'* are long ties, *b b'* are the regular ties, and *c, c, c* are braces to keep the ties in proper place.

When square sets are used or where the sills of round sets are hewed on the upper side, a long tie is spiked upon it, or the sill itself may take the place of *a a'*, but this requires greater care in ballasting and "lining up" the tracks.

**1561.** Where the dip does not exceed  $40^\circ$ , the height of the slope is made about the same as the height of the entries or gangways, but it is never desirable to have the height less than about 6 feet.

Slope timbers are set leaning up the pitch a few degrees less than right angles to the dip, for reasons given hereafter.

**1562.** There are many methods of jointing timbers, but those given are as good as any forms in common use.

In the notching of timbers, there is a general principle of right and wrong. The joints should be cut so that every square inch shall have a uniform bearing. If the joint is poorly fitted, the whole weight will be thrown on a small surface, which will give way.

Care must be taken not to reduce the strength of the set too much by having too much spread, or batter, on the legs. Just what the batter should be is a debatable question, but it should not exceed 1 in 6 or 1 in 5.

**1563.** Where it is necessary or desirable to dispense with the center prop of a wide set of timbers, the following methods (Figs. 482 and 483) are employed. Besides the

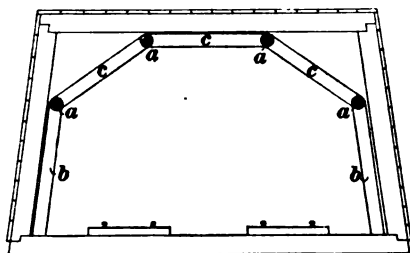

FIG. 482.

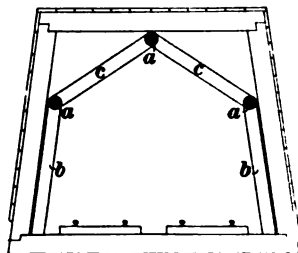

FIG. 483.

usual set of squared timber, there are pieces *a, a* running along the slope, with props *b, b* and braces *c, c*, the whole, as shown, approximating to the form of an arch.

**WALLING.**

**1564.** When the price of timber becomes more than that of brick, or where timber strong enough to give the

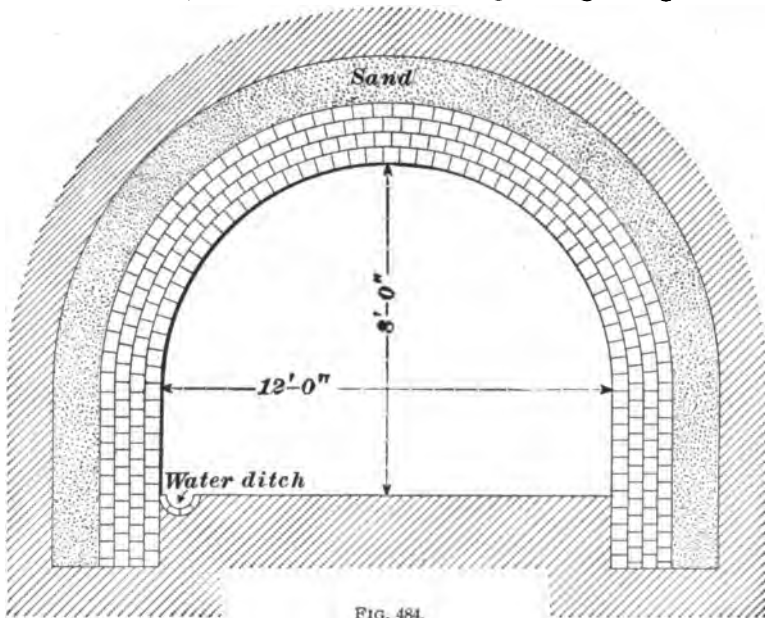

FIG. 484.

required room and security can not be placed, a stone or brick arch is built. When the bottom is hard, but the top is friable, the construction shown in Fig. 484 will meet the requirements; but where the ground is all weak, the method shown in Fig. 485 will give the best results. In building these, sometimes the side walls are built of stone and the arch with brick. The thickness of the masonry will depend upon the

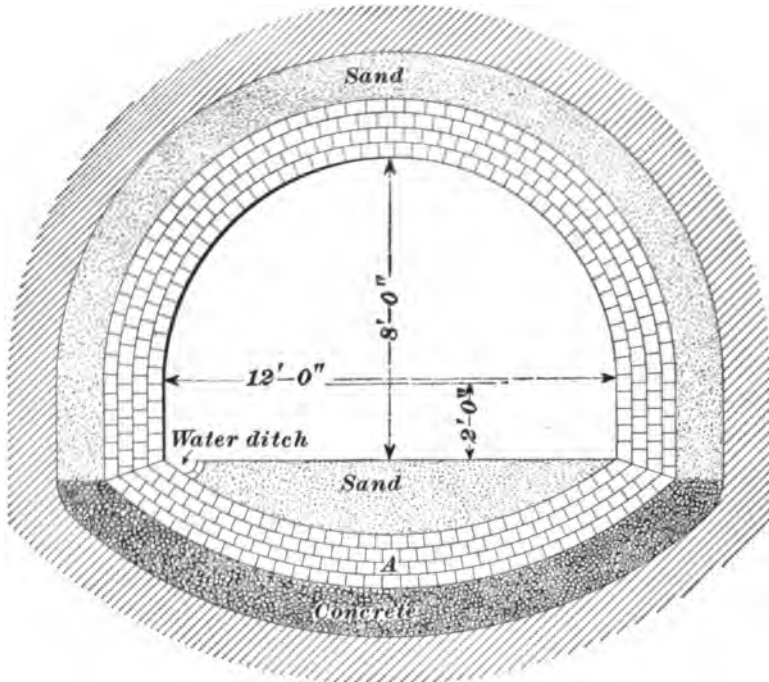

FIG. 485.

nature of the brick or rock used, but should never be less than 9 inches to 12 inches. Figs. 484 and 485 are for double roads where a wide car is used. When the structure has an inverted arch *A*, the invert is kept in advance of the side walls and the arching is built upon it. When an invert is used, the masonry is in three stages of construction, viz., invert, sides, and arch. When there is no invert, then there are only two stages.

Instead of the usual wooden templates, or frames (curved

frames which have the form of the invert and arch), iron templates are used for turning the invert and arch.

Where a heavy lateral pressure is expected, the sides of

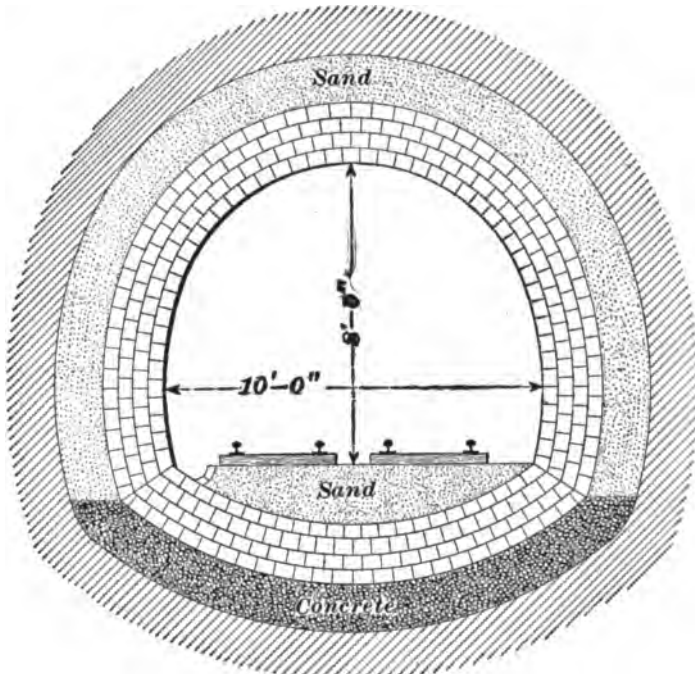

FIG. 486.

the arch should be concaved from their intersection with the invert, as shown in Fig. 486.

Fig. 487 shows an elliptical arched roadway, which is the strongest form that is suitable for mine roads. The circular is not practicable. The elliptical form will resist pressure from any or all directions better than any of the other forms given.

**1565.** Very little mortar should be used between the joints when building any one of these forms of arches. No old wood or anything subject to decay should be put in or left behind the walling. When there is considerable water in the strata, the space behind the walling should be filled in with concrete. At great depths the crush is enormous,



and arches of great strength are thereby destroyed. It has been found that by packing the top and sides with sand to a

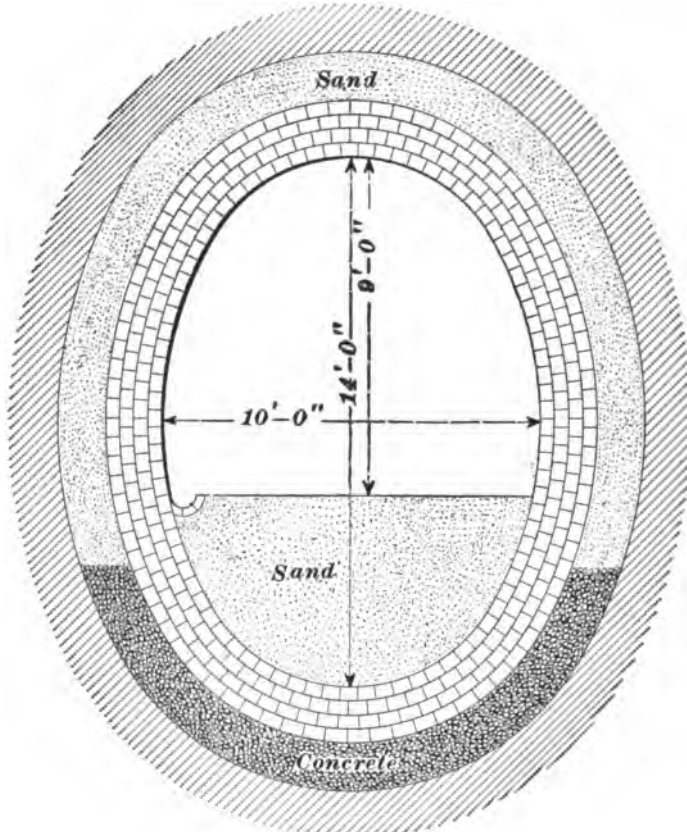

FIG. 487.

thickness of not less than one foot, the weight is distributed over the whole surface of the arch; consequently, it will stand a greater pressure.

#### SINKING OPERATIONS.

**1566.** In slope sinking, the operation of getting out the coal is accomplished in the same manner as when driving entries or gangways. The face is advanced by blasting out of the solid by means of flanking shots, alternating from one side to the other. Where the coal is hard enough to

blast, but not too hard to shear, the coal is "shorn" in the center from top to bottom and the coal on either side of this shearing is blown off the solid. In soft coal it is necessary to mine the coal, which may be done on the top or bottom, as the water will permit.

**1567.** In thick seams, where water is coming in freely, the upper portion of the coal is removed in advance of the bottom, the coal left forming a sump for the water. This lower coal may be advanced by leading the water to a small hole dug in the bottom, from which it is drawn by the pump, until the shot has been placed and fired. In thin seams this method is not practicable. Here some small proportion of the whole width must be kept in advance, either in the center or sides, from which the water is pumped. When there is no water, slope sinking is comparatively an easy matter.

**1568.** In "rock slope" sinking, the operation is on much the same principle. When air drills are used, however, the center is usually advanced first. A great deal depends on the judgment of the sinker in charge, and his skill may change the manner of procedure from time to time in order to get the benefit of natural advantages.

The tracks, together with the timbering or walling, are carried forward simultaneously with the sinking.

---

### DRIFTS.

**1569.** A horizontal, or nearly horizontal, opening driven in the coal from the surface above water level is termed a **drift**. When the seam of coal dips slightly inward, instead of starting the drift in the coal at the outcrop, it is best to start it some distance below and give it such a grade that when the drift is driven far enough for the first "parting" or "turnout," it will have reached the bottom of the coal seam. In this way an easy grade can be made for the loaded cars, whereby the haulage from the main parting to the tipple will be greatly facilitated. The cost of opening a drift in this way is but little greater than that

where the coal has a good natural pitch for haulage and drainage, except when the underlying strata are very hard, and even then the lasting advantage, accruing from a grade in which gravity assists the loaded cars, more than counterbalances the increased cost of properly grading the drift.

**1570.** When it is found advantageous for haulage and drainage to open up a coal field along its outcrop, where sufficient height can not be obtained below the level of the coal seam for the tippie, the difficulty is overcome by means of an inclined trestle plane, up which the coal is hoisted from the drift mouth to the dumps on the tippie. Sometimes under these circumstances the opening is made far enough above the level of the coal seam to secure sufficient height for the tippie, and it is driven down to the coal. In such a case the opening would be termed a *slope*.

**1571.** The location of a drift is partially determined by the outcrop; otherwise, it is fixed by the same conditions which determine the location of a shaft or slope.

Drifts are largely used in the bituminous region of the eastern part of the United States, and also in the anthracite region where the seams are exposed in ravines or gorges across the strike of the coal measures.

Where it is possible to open a coal field by a drift, it should be done, because both pumping and hoisting machinery can be dispensed with.

**1572.** Drifting is advanced in the same manner as a slope, both in regard to timbering and excavating the strata. The operation is, however, much easier, because the drift is of such a grade that the water will run away from the face and not trouble the workmen, and the timbers are set vertically.

In the bituminous fields there are usually two drifts, driven into the coal parallel to each other, one of which is used for the main haulage way, and the other for an airway, in front of which is placed the fan.

# METHODS OF WORKING COAL MINES.

(PART 1.)

## PILLAR AND CHAMBER METHODS.

### SHAFT PILLARS.

**1573.** There are necessarily a great many methods of working coal mines, because coal not only varies widely in its physical properties, but is found in different strata, and at different depths and inclinations. All the methods, however, may be classified in a general way under two principal divisions, viz.: *Pillar and Chamber* and *Longwall* methods. Either of these two divisions may be so modified as to make it difficult to determine whether the modified method should be called Pillar and Chamber or Longwall.

**1574.** After a shaft has been sunk to the seam, the levels, entries, headings, gangways, or galleries to communicate with every part of the territory to be mined are turned off. Whatever the method adopted, no coal should be mined for a certain distance around the shaft except for the opening of roads. The pillars thus left should be large enough to protect the shaft from rupture.

**1575.** The size of the shaft pillar depends on:

1. *The Depth of the Seam.*—Because the pressure of the superincumbent strata increases with the depth.

2. *The Inclination of the Seam.*—Because the plane of fracture lies between the vertical and a line drawn at right angles to the pitch, and what is known as the “zone of subsidence” diminishes in height as the pitch increases.

The working of a seam causes the overlying strata to settle, and produces what is called “subsidence.” If the seam is horizontal and not too deep, this subsidence will reach the surface and be greatest at a point vertically over

the center of the excavation; but, if the seam is deep-seated, the settlement may not be perceptible at the surface. In case the subsidence reaches the surface, its limits bound what is called the **zone of subsidence**. If it does not reach the surface, a dome is formed, and we have what is termed the **dome of subsidence**. When the strata are homogeneous and horizontal, the dome of subsidence is symmetrical and its axis is vertical; but when the strata are inclined, the dome is not symmetrical and its axis is inclined. As the inclination of the strata approaches the vertical, the height of the dome becomes less. When the zone of subsidence crosses strata of varying inclinations, the axis of the dome is deflected; and, if the strata are soft and loose, the dome may reach far beyond the limits of the excavation, especially if the strata contain water. In all cases the plane of fracture of stratified rocks lies between the vertical and a line perpendicular to the strata.

3. *The Nature of the Overlying and Underlying Strata.*—Because the nature of the strata affects the *domes* variously, that is, the hardness, elasticity, plasticity, compressibility, etc., are conditions which affect the result. If the rocks are hard and brittle, the fall increases in volume much more than if they are plastic. If they are firm and cohesive, they yield only under forces very much greater than those which suffice to draw away soft strata. If it has elasticity, it transmits to a greater distance the pressure which it receives. The compressibility of rocks after expansion is also very variable. Therefore, over identical excavations domes are formed which differ in length, height, and width. When water is present with a soft fireclay bottom for the seam, it makes the protection of the shaft more difficult. The excessive pressure on the pillar of coal compresses the fireclay and also forces it up on the roadways, from which it must be removed; the process may go on indefinitely if the pillar is not very large, and may eventually destroy the alinement of the shaft.

4. *The Texture of the Coal.*—Because harder coal can withstand more pressure without crushing than softer coal, and is not so much affected by atmospheric influences.

5. *The Thickness of the Seam.*—Because the dome of subsidence, as a rule, develops in breadth and in height with the height of the excavation; however, there seems to be no direct ratio in the amount of subsidence to the height of the excavation.

It follows from the above considerations that in pitching seams the rise side pillars should be the larger, as shown in Fig. 488. Here, a

much larger pillar is shown on the rise side than on the dip side of the shaft. The vertical lines are shown dotted at  $a b$  and  $a' b'$ , and the lines at right angles to the dip are shown dotted at  $a c$  and  $a' c'$ . The lines of fracture are shown solid between the dotted lines. On the rise side, the line of fracture approaches the shaft, while on the dip side it goes away from the shaft.

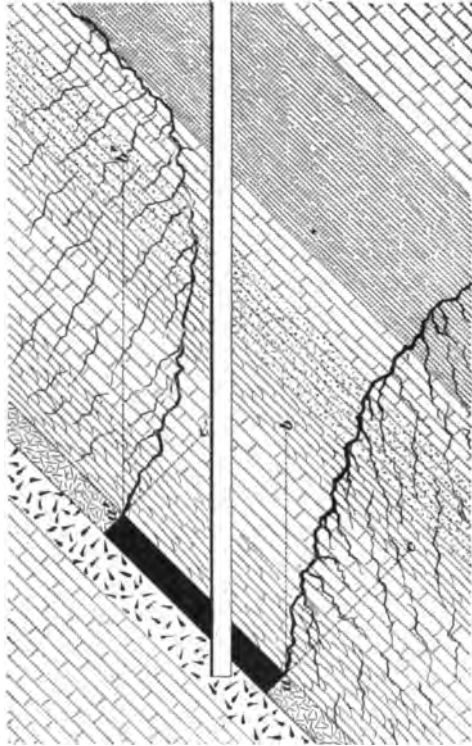

FIG. 488.

There is, perhaps, no point in mining on which so much diversity of opinion exists among authorities as on the size of shaft pillars required under given conditions. Any accident to the shaft caused by a pillar of insufficient size entails great expense and loss of output, and it is better, therefore, to err on the side of safety in this matter.

**1576.** *The size of pillars is generally determined by experience in the district in which the shaft is sunk.* The measurement of the pillars in many successful shafts indicates that the radius of a circle representing the minimum area of the shaft pillar should be (in flat seams) about one-fourth of the depth of the shaft, for shafts less than 700 feet deep. That is, a shaft  $533\frac{1}{2}$  feet deep should have  $\frac{533\frac{1}{2}}{4} = 133\frac{1}{4}$  feet of solid coal all around it; or, with the shaft as a center and with a radius of  $133\frac{1}{4}$  feet, describe a circle within which no coal (excepting for necessary passages) should be mined.

There are, at most shafts, heavy winding and pumping machinery, machine shops, etc., and it is important that the draw, or disturbance of the strata, should not reach them. If these are close to and all on one side of the shaft, the radius on that side should be increased to the distance these buildings extend from the shaft, provided the shaft is less than 700 feet deep. For example, if the buildings extend 100 feet from the shaft on one side, then the radius on that side should be  $133\frac{1}{4}' + 100' = 233\frac{1}{4}$  feet. Again, if the buildings are on all sides of the shaft, the furthest one being

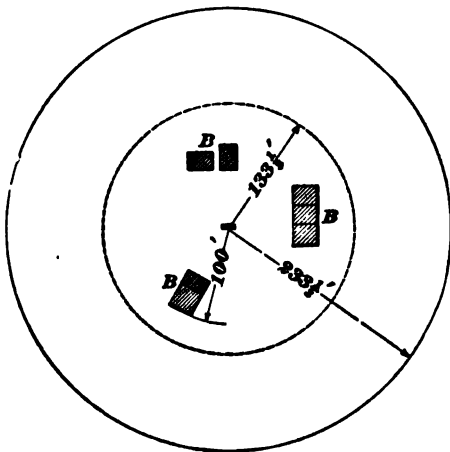

FIG. 489.

and the great circle shows the size of the pillar necessary to

100 feet from the center of the shaft, the radius should be increased just that much; or  $133\frac{1}{4}' + 100' = 233\frac{1}{4}$  feet will be the radius with which to describe a circle from the shaft as a center. This circle marks the pillar reservation.

The dotted circle (Fig. 489) shows the area of pillar left to protect the shaft only,

protect the shaft and the buildings *B*, the furthest being 100 feet from the center of the shaft.

**1577.** For shafts deeper than 700 feet, a good formula for determining the approximate size of shaft pillar under average conditions is : radius of shaft pillar =  $3 \times \sqrt{D \times t}$ , where *D* = depth of shaft, and *t* = thickness of seam. Thus, a shaft 900 feet deep, which is sunk to a seam 8 feet thick, should have a pillar whose radius =  $3 \times \sqrt{900 \times 8} = 254.56$  ft. When a shaft exceeds 700 feet in depth, it is seldom necessary to provide extra pillar for buildings, unless the seam is extraordinarily thick.

Great care should be exercised in determining the size of shaft pillars in districts where experience has not already determined the best dimensions.

---

#### SLOPE PILLARS.

**1578.** These pillars depend on the five principal points mentioned in speaking of shaft pillars. However, there is not much danger of the draw destroying the slope, because the line of the slope is nearly at right angles to the plane of fracture, whereas in a shaft, the line of the shaft and the plane of fracture converge in pitching seams.

**1579.** By assuming that a mass of strata receives no support by virtue of its own strength or adhesion to the surrounding strata, which is true over large areas, it may be inferred that pillars will be subject to weights varying directly as their depth from the surface, multiplied by the cosine of the angle of dip. Therefore, pillars should increase in size as the slope advances downwards. What the exact increase should be can not be determined definitely enough to warrant the formation of a rule.

For a close approximation of the size of pillars required at the bottom of a slope, when conditions are normal, the formula  $3 \times \sqrt{D \times t}$  (see Art. **1577**) may be used, in which *D* should represent the *vertical* depth of the slope below the surface, and *t* the thickness of the seam. The



pillar on either side should not be less than 50 feet wide at any point.

Squeezes on slopes are of frequent occurrence. This indicates that the usual practice, which does not provide for the increasing pressure due to increasing thickness of strata, is faulty.

**1580.** When the strata immediately overlying the coal seam are comparatively brittle and fall into the excavation, considerable weight is taken off the adjacent pillars, and when the fallen débris is sufficient to fill the opening, it also supports, to some extent, the overlying strata. If the overlying strata are strong, and do not break, the adjacent pillars must not only support the strata immediately overlying them, but the strata overhanging the worked-out portions as well. Therefore, to avoid a squeeze, larger pillars are required under a strong roof than under a brittle one. If the top is hard and strong and the bottom soft, still larger pillars are required to prevent, as much as possible, the squeezing of the pillars into the bottom.

In any case, if ample pillars can not be left in to completely support the roof, it is best to induce a fall of the strata if possible, so that the weight may be lessened and that the expanded débris may take a portion of the weight off the pillars.

**1581.** The slope pillars in no case should be less than 100 feet wide, and in many cases they are 200 feet wide. This latter width includes all passages, usually two, sometimes three, and occasionally four—all parallel with each other. The laws of Pennsylvania require at least 60 and 30 feet, respectively, in the anthracite and bituminous regions, between main passageways.

Fig. 490 is a plan showing two slopes with parallel airways; *s s* is the advancing or sinking slope; *h h*, the hoisting slope; *a, a*, the airways, and *r, r*, the rooms.

**1582.** Shafts should be sunk so that the track on the cage will be parallel with the strike of the seam. This permits the running of the mine cars on the cage direct from

the mine tracks. Slopes should be sunk on the full dip of

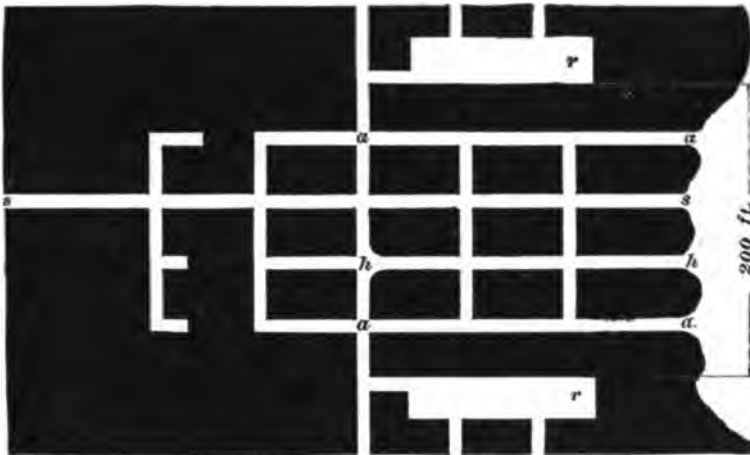

FIG. 490.

the seam, to secure stability of track and convenience at the bottom landing.

**SLOPE LANDINGS AND SHAFT BOTTOMS.**

**1583.** When the slope is driven on the full dip, the landings or turnouts are usually made on each side on the strike of the seam. Beginning at a short distance from the slope, the gangway is widened out to from 12 to 20 feet, or more, depending on the space required for men, mules, cars, etc. It is carried forward at this width far enough to accommodate such a number of cars as will ensure a constant supply to handle the coal in that lift. When the top is weak, these landings must be timbered in pretty much the same manner as the slope. When the gangways or headings are driven at a sufficient distance from the slope, turnouts are made exactly the same as the landings. On these turnouts the loads are collected and hauled in larger trips to the landings. As the loaded and empty cars have their special tracks, spring-latches are advantageously used at both ends of the turnouts.

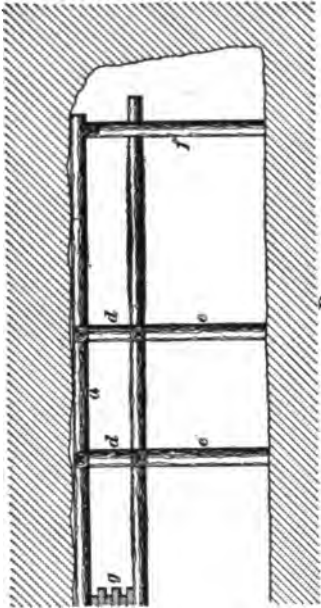

FIG. 401.

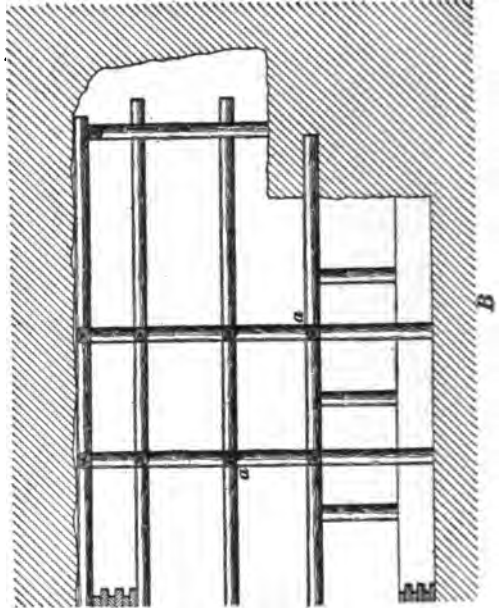
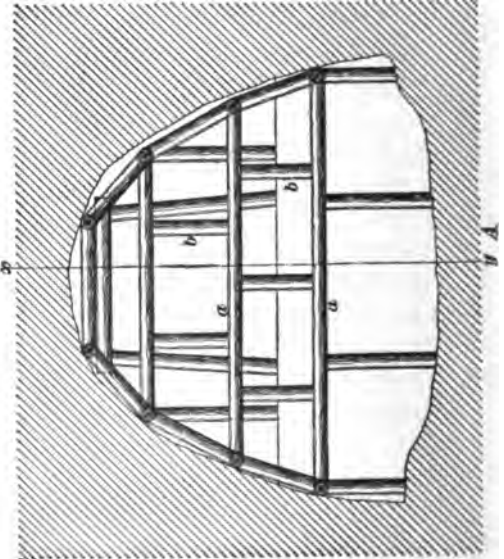
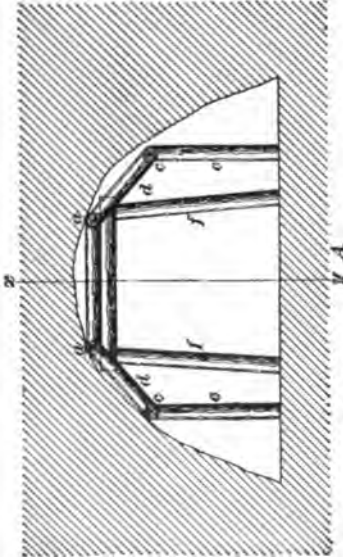

FIG. 402.



**1584.** Shaft bottoms are usually fitted up very substantially, as they generally have a longer life than any landing or turnout in other parts of the mine.

**1585.** The empty and loaded tracks in landings, turnouts, and shaft bottoms have a slight fall in the direction the car travels, varying from about  $0^{\circ} 35'$  (1 in 100) to  $1^{\circ} 10'$  (1 in 50) depending on the size of rail, the size of car wheels, etc.

**1586.** When the shaft bottom has a frail top, or other conditions prevail which necessitate arching, the following plan is pursued:

The arches are built in lengths of from 6 feet to 10 feet, varying with the nature of the ground. The first operation in arching is to remove the material. This may be accomplished by driving a small road at the top of the ground to be excavated, and then removing the material from both sides and downwards; or by driving the small road at the base and removing the ground from the sides and upwards. In carrying up the temporary timbering, all the main sticks are set parallel to the road, so that they may be removed as the masonry is brought upwards. When props are used in the center of the excavation, the small end should be down, because when the masonry in the invert (floor arch) is built around them, other props are set on the masonry, and the old ones can be easily removed. If the large end is down, the props can not be conveniently removed.

**1587.** Figs. 491 and 492 show the method of timbering in two stages. In Fig. 491, *A* is a cross-section and *B* is a longitudinal section on the line *x y*, where the top head has been driven. Two long bars *a, a* are set with one end of each resting on the arch *g* and the others on the set of timbers *f*. They are connected by horizontal struts. The ground is first excavated on the sides, and longitudinal bars *c, c* are put in and connected by struts *d, d*, and lagging is placed behind them, if the ground requires it. Fig. 491 represents the work at this stage, the two longitudinal pieces *c, c* being supported by props *e, e* set on the floor.

As the excavation proceeds downwards, the props *e, e* are

removed as soon as space is made for other longitudinal pieces. This process goes on until a complete lining, consisting of longitudinal bars and cross-struts between them, exists all around the excavation. In heavy ground, the longitudinal pieces are often connected by transverse bars  $a, a$ , Fig. 492. Vertical props  $b, b$  are set between these bars until, at the completion of the work, the appearance is as shown in Fig. 492, where  $A$  is a cross-section and  $B$  a longitudinal section on the line  $xy$ . The masonry is now commenced. A lining of sand is spread in the bottom, and shaped to the curve of the brickwork. A wooden frame or "template," built the exact shape and size of the finished dimensions of the inside of the arch, is fixed at such a height above this sand as will allow the thickness of the brickwork decided upon to be placed between it and the sand. The bottom arch or invert is built first; then the sides are continued until they meet in the center line at the top of the arch.

**1588.** In most of the shaft bottoms in America, cars are caged from both sides, there being an empty and a loaded track on each side. It is often necessary to pass cars from one side to the other, and because the law (of Pennsylvania) requires a passage around the shaft, the bottom is so arranged. In well-arranged collieries, the caging is all done from one side, and the cars travel in the direction shown by arrows in Fig. 493, the tracks having a down grade in that direction.

Perhaps the most satisfactory arrangement of a shaft bottom, where conditions are favorable, is shown in Fig. 493, in which  $P$  is a plan and  $K$  a section of the roads. The method of handling the cars is as follows: A loaded car is taken from the road  $a$  to the shaft  $s$  by way of the road  $d$  or  $e$ , depending upon which cage is down, and by it the empty car standing on the cage is bumped off and run by gravity to the point  $b$ , and by virtue of its start it ascends the steep grade  $bc$  sufficiently far to give it force enough when it reverses to run along the road  $bgd$  far enough to accommodate a trip of cars. At the point  $b$ , there is a pair

of spring-latches allowing the car coming from the cage to pass through them, but always keeping adjusted for the road *b g d*. The grade from *a* to *s* is usually from 1 to 2 per cent..

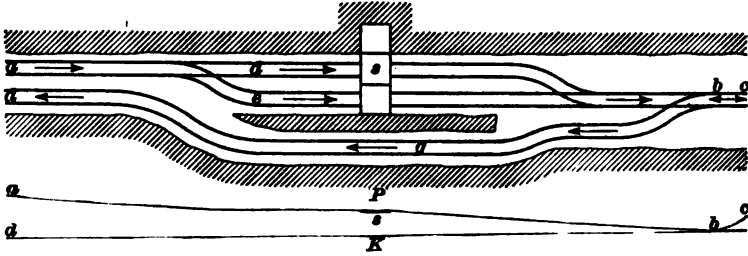

FIG. 498.

that from *s* to *b* is from 5 to 10 per cent., or more, depending upon the distance between these points, and that from *b* to *g* is about 2 per cent., beyond which point the road is made level for any desired distance. By this method men are required on that side only of the shaft on which the loaded cars are handled. The arrows indicate the direction in which the cars run.

**1589.** Fig. 494 shows a somewhat more complicated arrangement of a shaft bottom in which several pairs of headings branch away from the immediate vicinity of the shaft. In each pair of headings one heading is used for the loaded and the other for the empty cars. The loaded cars reach the shaft on one side only by the roads marked *l*, and, as in plan shown in Fig. 493, the loaded car bumps the empty car off the cage, causing it to run down the grade *s b* and thence up the grade *b c* to a point where it reverses and runs back, taking the road *f* or *e*, depending upon where the trip is being made up. If it takes the road *f*, it may be switched on to the road *g* or *h* or allowed to continue straight on, depending upon where the car is wanted. The arrows show the direction in which the cars run; *p* is a pump-heading, *r* a room heading, and *m* a manway around the shaft. The space *w* in the heading *k* is for stables, tool-house, etc. The grades are made so that the cars run to place by gravity.

**1590.** Where double or triple-decked cages are used, the arrangement of the shaft bottom is a more complicated

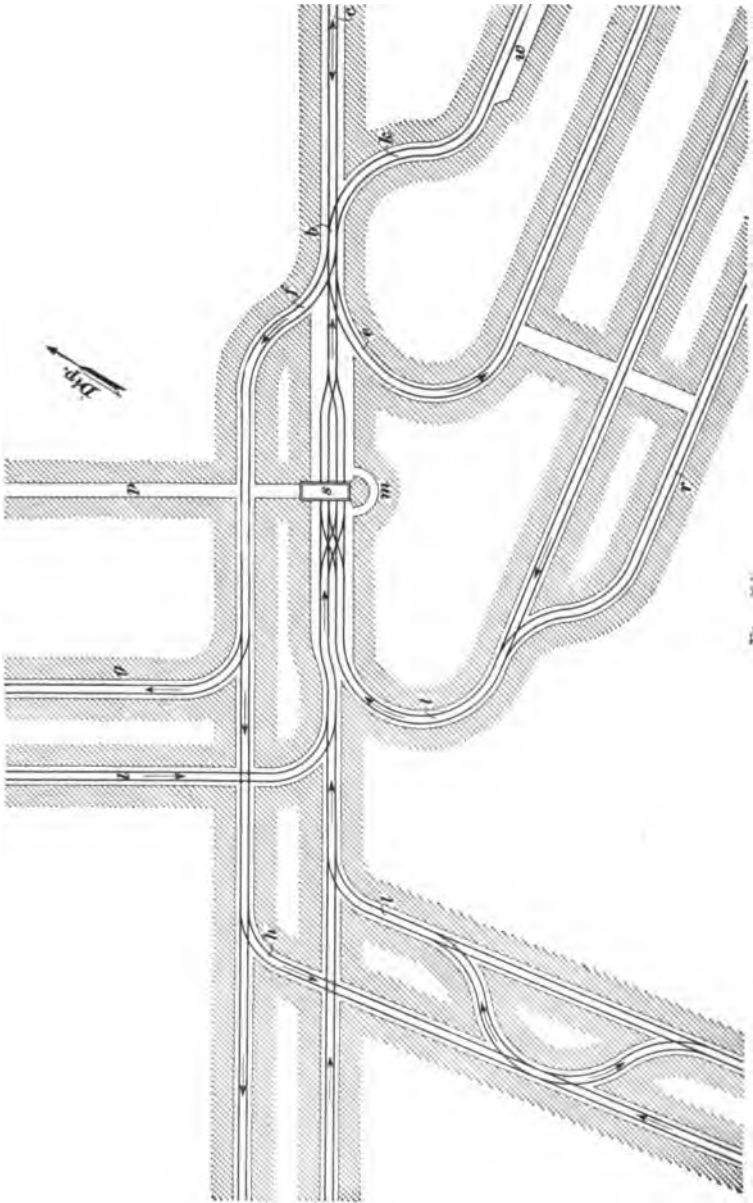

FIG. 404.

matter. By the arrangement shown in Figs. 493 and 494, the gradients are so arranged that the movement of the loaded and empty cars is almost automatic. When there is more than one deck, this arrangement will only suit when the position of the cage is changed to bring each deck alternately on a level with the shaft bottom. Each change will take nearly as much time as hoisting one car to the surface by a single cage. To overcome the difficulty of changing the position of the cage, the bottom is arranged to suit the decks of the cage, the loaded car being lowered to the deck-level and the empty cars being raised to the level of the seam by an inclined plane or an engine. When there is considerable dip to the seam, if the production from each side is equal, two decks may be used by making the bottoms independent of each other, at levels suiting the *decks* of the cage.

**1591.** Where endless chain or rope haulage is in use, the cars may be made to pass at will from one landing to the other by simply arranging the chains or ropes to suit the conditions.

---

## PILLARS IN THE MAIN WORKINGS.

---

### SIZE OF PILLARS.

**1592.** In determining the size of the pillars for the main workings, at least five points are considered:

1. *The Ventilation Required.*—If there is much firedamp or chokedamp given off, or much powder used, the formation of long pillars without cross-cuts necessitates a special and expensive mode of ventilating each working face by carrying a board or canvas brattice from the nearest cross-cut to the face. This enables air to be carried to the face along one side of the brattice, and returned along the other. In some cases where considerable good building material is obtained from the waste, packwalls a few yards wide and built close against the roof take the place of the brattices.

2. *The Nature of the Roof and Bottom.*—Where the roof, or bottom, or both are soft, large pillars and long narrow



openings are required. Frequently the top is supported by the pillars and props for a long time. The weight, which tends to crush the coal, and disintegration by atmospheric agencies, necessitate in such a case larger pillars.

3. *Depth of the Seam.*—To obtain better proportioned pillars, the best practice seem to indicate that the pillars should be not only larger, but the proportion of their widths to their lengths should increase as the depth increases.

4. *The Detailed Mode of Working Adopted.*—This has a very great influence on the size of the pillars.

5. *The Tonnage Required.*—As a general thing, short pillars are most favorable to the production of large outputs.

---

#### **DIRECTION OF PILLARS.**

**1593.** Speaking in a general way, pillars with their longest sides parallel to the pitch of the seam are the strongest and most suitable. However, it is very desirable to have the rooms, and, consequently, the pillars, running parallel to the "butt" cleats and perpendicular to the "face" cleats of the coal, thereby securing the better and cheaper coal. Sometimes, when the inclination is very great, it is found that the cost of hauling the coal is reduced by making the rooms and pillars run parallel with the strike of the seam. In cases where the course of the haulage road is diagonal to the course of the rooms, care must be taken in setting out the first range of pillars, so that those following may be of proper size. Errors due to neglect of this precaution are troublesome.

---

#### **PROPORTION OF PILLAR TO OPENING.**

**1594.** When an undue proportion of coal is mined in the first working, creeps are induced, with all the accompanying evils of crushed coal, the dilapidation of roadways and airways, the consumption of labor and material, and the suspension of the power of production, while additional expense is incurred in repairing the damages arising from such indiscretion. In fixing the proportion of pillars to openings, the following important points must be considered:

1. *The Nature of the Coal.*—Some seams are of such a nature that the sides and corners of pillars chip or split off when the coal is opened up, thus causing considerable waste. This splitting or chipping is due to the disintegrating effect of the atmosphere, or to pressure of gas in the coal, or to the pressure of the roof, or to any two of these causes combined, or to all three. When this chipping or splitting off of pillar coal occurs, pillars of greater area are required.

2. *Nature of Roof and Floor.*—If the floor is soft and the roof hard, small pillars are so squeezed down as to be both troublesome and expensive to remove, and the floor is very liable to “creep.” If the floor is hard and the roof brittle, the latter will fall more or less in spite of all efforts, and the expense of “cleaning up” and timbering is heavy. If top and bottom are both strong, the weaker substance—the coal—is crushed, and its value proportionately decreased.

3. *Inclination.*—A very hard roof, such as a sandstone or limestone, will not break down in the ordinary working places, and so all the weight remains on the pillars until their removal begins. Then, although in pitching seams the amount of pressure varies inversely as the inclination, and is less than in flat seams, there is great danger of a rush or movement of the strata over the pillars, when robbing or withdrawal begins, unless they are large in proportion to the openings.

4. *Dislocations.*—These cut up the strata, and when of large size and running in certain directions, necessitate a greater proportion in pillars to withstand the pressure of the dislocated and subsequently loosened roof, when a subsidence is brought on by the removal of the pillars next them. If no attention is paid to dislocations, disastrous “crushes” may ensue, destroying acres of pillar coal.

5. *Depth.*—The depth of the seam is really the measure of the pressure. The aggregate power of resistance of the pillars must not merely sustain this pressure during the first working, but it must have such a surplus, and that so distributed, as to ensure the safe, economical, and entire

extraction of each pillar in turn. A depth may be finally reached when the pressure can not be resisted by pillars of any size, and the pillar method must be abandoned. The limit of depth varies with the nature of the coal, inclination, nature of strata, etc. In the foregoing, the conditions affecting the formation of pillars in the first working of the pillar method (often called working in the "whole") have been considered. It is now in order to treat of the second working, sometimes called the "brokens," which is the removal of the pillars. This requires the exercise of sound judgment and much good practical skill.

#### PILLAR DRAWING.

**1595.** Generally speaking, the sooner, consistent with economy, that the pillars are removed the better. In gaseous mines the pillars ought not to be taken out until the workings have reached a considerable distance from the shaft. If the coal is tender, the strength of the pillars should be considerable, and their removal delayed; because, if they are taken out, the probability is that those left for the support of the passages will be destroyed by the pressure, especially if the roof is good. In the case of bad roof, the pillars should be taken out as soon as possible, not only for economy, but also because, when the roof is bad and falls freely in the gobs, the débris soon sustains the superincumbent pressure and relieves the weight on the pillars next the hauling or main roads. Early drawing of pillars also concentrates the working district, and gives greater facilities for keeping up a limited extent of workings, and makes the ventilation more efficient and simple.

**1596.** In some cases the following conditions must be considered before pillar extraction is started :

1. *Working Contiguous Seams.*—When two or more contiguous seams are worked simultaneously, the removal of the lower pillars may very seriously affect not only the economy but the safety of the operation above. It may, therefore, be better policy to leave the pillars in the lower seam a much longer time than if there was but one seam.

2. *The Character of the Roof.*—If the roof is very strong and the area of pillar drawing is comparatively limited, a very dangerous amount of weight will be thrown on the remaining pillars; or, if the faces are not sufficiently far advanced, the disturbance produced in the strata may extend far enough to injure them.

3. *The Amount of Water that May be Let into the Workings by the Subsidence of the Roof.*—When a water-bearing stratum lies within the probable zone of subsidence, care must be taken not to disturb it.

4. *Surface Damages.*—In some cases, the immediate consequence of drawing the pillars will be the subsidence of the surface, which may result in large claims for damages.

**1597.** The conditions at collieries are so varied that no rule can be laid down to suit all. The effect of pressure varies with the nature of the roof and floor.

If the roof has fallen in the rooms, the drawing of a pillar can be most advantageously accomplished by taking a skip or slab off one side, advancing from the mouth of the room, and finally taking the remainder on the retreating plan. If, however, the roof is so strong that the entire extraction of a pillar is accomplished without inducing a fall, an enormous weight is thrown on the adjacent pillars. This has a tendency to crush the pillars if the floor is hard, or to force them into the bottom if it is soft.

**1598.** The order in which pillars are removed is important, as it affects both the safety and economy of the work. In working pillars on a pitch, a lower range should not be commenced till those immediately above are finished. In drawing pillars, their ends should be kept in a *straight* line. If they are not, some pillars are subjected to greater pressure than others, valuable coal is lost, and the work is materially interfered with. When all the pillars are left standing till the boundary is reached, the pillars are best drawn outwards.

**1599.** There are several ways of drawing pillars. When a pillar is small, it may be removed by one operation, but

when it is large, a skip or slice is often taken off its entire length and the remainder removed in the same manner as a small pillar.

In other cases, when the pillar is large, a narrow place is driven across or up the center, splitting the pillar in two, and then the two portions of coal left at the sides are brought back together. This is practised in some parts of the anthracite coal fields of Pennsylvania.

**1600.** Care must be taken to work out the coal without leaving small stumps, or portions of pillars, scattered through the gob, as they interfere with the uniform breaking of the top. When the surface must be kept up, and the pillars are large, skips or slices may be taken off them. This operation is termed **robbing** or **skipping** the pillars. When the pillars are entirely removed, the operation is termed **drawing the pillars**.

---

#### THRUST AND CREEP.

**1601.** Thrust and creep are both due to insufficient pillars. When the roof and floor are strong and unyielding, and the pillars are insufficient to withstand the pressure thrown upon them, they are filled with breaks and cracks, large pieces split off, and the pillars are finally crushed into small coal. The roof comes down, thrusting the coal out, and the result is known as a **thrust** or a **crush**. When the material composing the floor or roof, or both, is soft and weak, and the pillars left are too small, the weight upon them causes the roof to sag, or the floor to bulge, or both. This result is known as a **creep**. A thrust and a creep may both be going on at the same time.

**1602. Stopping a Creep or a Thrust.**—When any sign of a creep or a thrust appears, the pillars should be re-enforced as much as possible by wooden chocks, or nogs, and by supports of any kind that can be put up just outside of the part affected. If the action of the creep or thrust is slow, sometimes the coal is extracted rapidly from some pillars, which will allow the top to break and thus relieve

the standing pillars of some of the weight. *A creep or thrust can not be prevented by any means when it has set in, but it may be confined to a limited area, if caught in time, by reconfirming the pillars as stated above.* The creeping or thrusting will go on until the excavations are filled, and the whole becomes compact enough to resist the weight. This sometimes takes many months, but it is a sure result, be the action fast or slow. Confining a creep or a thrust to a certain limit is a difficult, expensive, and dangerous operation, requiring the utmost skill and care in every individual engaged in the work.

**1603. Reopening.**—After the subsidence has entirely stopped, the pillars of coal subjected to thrust or creep may be partially recovered by methods adapted to the thickness of the seam. Thin seams can not be opened very readily, and, indeed, unless the coal is very valuable, reopening thin seams seldom pays. The old entries must be reopened by taking up the bottom, or taking down the top rock, which must be stowed in any open place, or taken to the surface, or by driving new entries across the pillars; in any case, much rock must be handled. In thicker seams, say over 6 feet, it is customary to make new roads by skipping the pillars; i. e., by taking a strip off the side of the pillars wide enough to carry a road under new top. In such cases, much timber must be used on the broken side, and where the road is carried across the waste or old excavations. Moreover, a district may again begin to creep or thrust whenever work is renewed on the pillars. In most of the cases tried, in many ways, and under many different circumstances, the operation was very unsatisfactory.

---

#### METHODS OF WORKING BITUMINOUS SEAMS.

**1604.** Fig. 495 shows seven districts worked on the "Pillar and Chamber," "Pillar and Stall," and "Panel" systems, principally in vogue in the bituminous coal fields of the United States. Several methods can frequently be combined to advantage in the same mine.

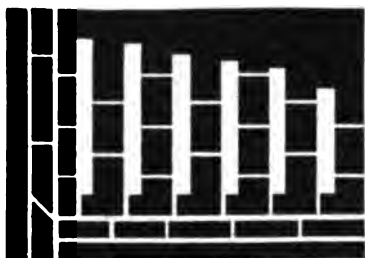

*District 1*



*District 2*



*District 3*



*District 4*



*District 5*

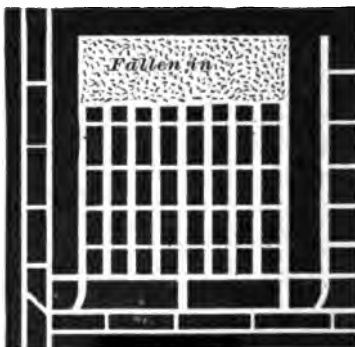

*District 6*

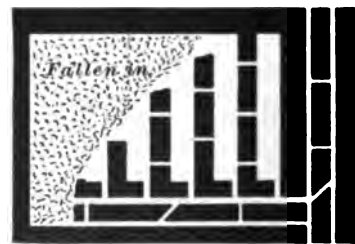

*District 7*

FIG. 495.

Most mines in the bituminous regions of the United States are opened up by the **double-entry system**. In this system, the main and butt, or productive, entries are driven in pairs and in definite directions suitable for the most economical and advantageous working of both the rooms and the pillars. The **triple-entry system**, which consists of a main entry or intake in the center and a return air-course on each side, is used either where the seam generates a large amount of gas, or for the purpose of getting out large quantities of coal, particularly when mined by several different systems.

**1605.** District 1 represents a group of "breasts," "rooms," or "chambers" which are driven about 6 yards wide and 12 yards apart. Narrow cross-cuts, called "break-throughs," are driven from room to room for ventilation. The heading from which the rooms are turned off is the haulage road, and the other heading is simply an airway. This system is used where the pillars are to be left in for the purpose of preventing any serious settlement of the surface, whereby buildings may be injured or water let into the mine.

**1606.** District 2 is a group of rooms showing the method generally used where the roof is good and the dip of the seam does not exceed 8 degrees. The rooms are about 8 yards wide and the pillars 6 yards wide. Where the dip is 3 degrees or more, the rooms are turned off to the rise only, the lower heading being used simply as an air-course. There is no road in the air-course, except near the face, the coal being taken out to the principal entry through diagonal cross-cuts at intervals of about 60 yards. When a new diagonal cross-cut is completed, the road is taken up in the one just back of it and is laid down in the one just finished. The rooms are turned off up the pitch, thereby avoiding any hard pull while taking the loaded cars from the face. When the seam pitches less than 3 degrees, butt headings are turned off the main headings, in pairs, at intervals of about 200 yards, and rooms are turned off both butt headings to the



right and left of each pair. This method, when it can be used, requires only one-half the number of butt entries required by District 2 to develop a mine. Also, when the butt entries are driven to the rise, the rooms are turned off to the right and left along the strike.

**1607.** District 3 shows a manner of grouping rooms where the dip is greater than that for which group 2 is used, and may be used on pitches from 8° to 20°.

The straight heading is driven on the strike of the seam, and the other headings at such angles to it as will give a good grade for haulage purposes.

**1608.** District 4 shows a group of rooms, each of which is 36 feet wide, with a pillar of the same width on either side. There are two entrances or "necks" to each room, and two roads, one along each side, the gob or refuse being thrown in the middle of the room among the props which support the roof. Sometimes, where it is advisable to work the coal by wide pillars and rooms, more particularly wide rooms, the rooms are turned off, as in District 2, and a road is carried up the center of the first room, the gob being thrown on either side, and in the second room, two roads are laid as in District 4, except that the roads connect just before passing through the neck of the room. This is carried on alternately to the end of the district, and the pillars are drawn in the double-road rooms only.

**1609.** District 5 shows a group of rooms suitable to work a seam of tender coal, having a soft top and bottom, and lying about 300 feet below the surface. Narrow 12-foot rooms are driven 40 feet apart, and the pillars are drawn back by taking say 16 feet off the roadside pillar and 12 feet off the gobside pillar.

**1610.** District 6 shows a group of nine narrow rooms driven to the rise for 300 feet, and the pillars drawn back together. Between each section of nine rooms extra large pillars are left to break the rock in case of a fall, and prevent a squeeze on the adjoining section which may not have reached its limit.

In some cases, still narrower rooms are driven along the strike of the seam, in pairs; and between each pair, pillars 20 yards wide are left. Which method to adopt is determined by the nature of the coal, especially with regard to the relative prominence of its face and butt cleats. The method shown in District 6 is preferable where the cleats are equally prominent in face and butt; while in the case of a long-grained, tough coal, it would be best to work it by dividing the coal by pairs of rooms having wide pillars between each pair, as above described.

**1611.** This method of first driving narrow places say from 8 to 12 feet wide, and then drawing back the pillars, is termed **pillar and stall**. It will be observed that each group of rooms is surrounded by a large pillar in order that pillar drawing can commence in each group as soon as it reaches its limit. This gives us a system which will be explained next.

**1612.** District 7 shows a section of a mine worked on what is called the **panel system**. This system is a modification of the pillar and breast plan of working, by means of which a larger portion of the pillar coal can be obtained. It is not applicable to very thick seams, nor can it be successfully employed in steep-pitching seams. Where this system is used exclusively, the mine is laid off in "districts" or "panels," two or three acres in extent, and large pillars are left surrounding the area being worked within each panel. When the rooms of one panel are exhausted, the work of drawing the pillars is begun at the extreme end of the panel; and when this work is finished, all parts which may yet be standing are withdrawn so that the roof will firmly settle before the pillars in an adjoining panel are worked.

By the panel system, "creeps" are almost entirely prevented, the pillar or less expensive coal is gotten earlier, and good ventilation is secured, for each panel has its separate "split," or air-current. It is further maintained that, in case of an explosion, the damage may be confined to a particular panel in which it occurs. Any method may be

employed in developing the panel; in this particular case, the pillar and chamber method is used.

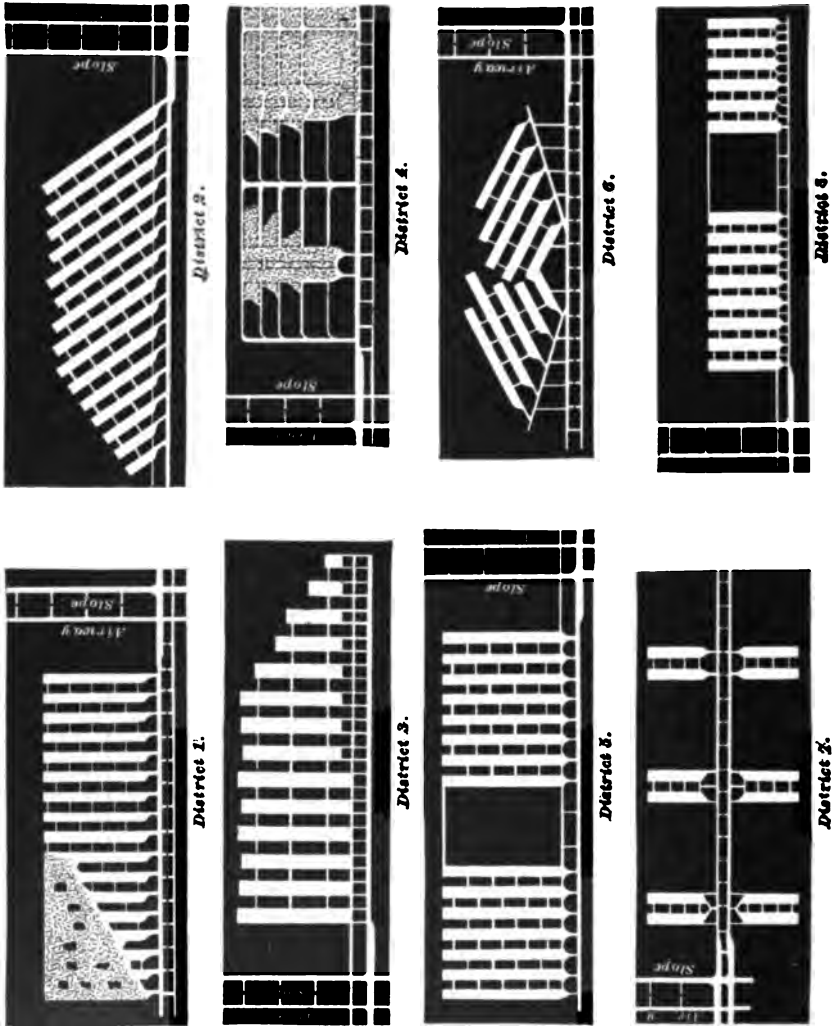

FIG. 406.

**1613.** It should be remembered that in all these districts the rooms are driven on the "faces," i. e.,

perpendicular to the face cleats, or as nearly so as possible, because more lump coal can be produced and the bearing in can be more easily effected than by driving them in any other direction.

There are conditions which require that the rooms should be driven at different angles to the face cleats; but these will be fully explained further on and need not be dwelt upon here.

---

**METHODS OF WORKING ANTHRACITE SEAMS.**

**1614.** Fig. 496 represents five different districts of mines in the anthracite coal region of Pennsylvania. These districts show in a general way the arrangement of the necks of the breasts for chutes best suited for particular pitches. This arrangement of the chutes, etc., will be explained in detail further on.

**1615.** In districts 1 and 2 the seam is nearly flat, and the coal is obtained in chambers varying in width from 20 to 30 feet. The coal is nearly all shot out of the solid, and a great deal is unavoidably lost in drawing back the pillars, the best results in thin seams being scarcely 80 per cent. mined. In district 1 part of the pillars are drawn, while in district 2 the rooms are not yet finished, and are driven obliquely to the level to obtain a moderate grade for haulage. A chain pillar which is parallel to the gangway and air-course is left between the different lifts, as the districts are called when on a pitch. Each of these pillars protects the lift immediately below it and prevents the water from running down into the lower lifts. Part of the chain pillar may be taken out when the lift just below it has reached its limit.

**1616.** The coal is supposed to have considerable pitch in districts 3 and 4. In district 3 the breasts are opened with two chutes each, and the rooms are 10 to 12 yards wide. In case there is a bottom split of the seam, one split should

be worked vertically above the other; that is, breast should be over breast and pillar over pillar. Sometimes an extra stump or small pillar is left immediately above the first heading or airway as an additional protection for the chutes and airway. In district 4 is shown a panel system devised by Col. D. P. Brown of Lost Creek, Pa., which gives good results in thick seams pitching from  $15^{\circ}$  to  $45^{\circ}$ , where the top is brittle, the coal free, and the mine gaseous.

In this plan of working, rooms or breasts are turned off the gangway in pairs at intervals of about 60 yards, as shown in district 4. The breasts are about 8 yards wide, and have a pillar between them about 5 yards wide, which is drawn back as soon as the breasts reach the airway near the level above. In the middle of each large pillar between the several pairs of breasts, chutes about 4 yards wide are driven from the gangway up to the airway above. They are provided with a traveling way on one side, giving the miners free access to the workings. Small headings are driven in the bottom bench of coal, at right angles to these chutes, and about 10 or 20 yards apart. These headings are continued on either side of the chutes until they intersect the breasts. When the chute and headings are finished, the work of getting the coal in the panel is begun by going to the end of the uppermost heading and widening it out on the rise side until the airway above is reached and a working face oblique to the heading is formed. This face is then drawn back to the chute in the middle of the panel. After the working face in the uppermost section has been drawn back some 10 or 12 yards, work in the next section below is begun, and so on down to the gangway, working the various sections in the descending order. Both sides of the pillar are worked similarly and at the same time towards the chute.

Small cars, or buggies, are used to convey the coal from the working faces along the headings to the chute where it is run down to the gangway below and loaded into the regular mine-cars. This system affords a great degree of safety to the workmen, because whenever any signs of a fall of roof

or coal occur, the men can reach the heading in a very few seconds and be perfectly safe.

It will be noticed that a great deal of narrow work must be done before any great quantity of coal can be produced by this system. The only reason that breasts are driven in pairs and at intervals, as above stated, is to provide means of getting a fair quantity of coal while the narrow work is being done; they are not an essential part of Col. Brown's system. It is claimed that the facility and cheapness with which the coal can be mined, handled, and cleaned in the mine more than counterbalances the extra expense for the narrow work.

**1617.** In districts 5 and 6 the seam is supposed to have a light pitch. In district 5 is shown a method of opening breasts with a single chute, in the center of which the coal slides on sheet iron. The breasts are worked from 8 to 12 yards wide and in groups of from 8 to 10 breasts. These groups are separated by strong pillars from 150 to 200 feet wide. These pillars are left in to prevent any very heavy crush affecting the gangway and working breasts, and to ensure the breaking of the top rock so as to relieve the pillars of excessive weight. In district 6 the seam is supposed to dip from  $10^{\circ}$  to  $15^{\circ}$ . This is not enough dip for chutes and too much for haulage roads on the full rise. Therefore, slant gangways or branch entries are driven off the main entry, and backswitch breasts are turned off them.

**1618.** In district 7 the gangway is supposed to be driven in the syncline or basin, and rooms are turned off to the right and left. Whichever system of opening the breasts is employed, the best results will be secured by carrying on the work in sections, or panels, having extra strong pillars of coal to support the overlying strata and as far as possible to lessen the crush, which is considerable under such conditions and at so great a depth. In district 8 the pitch is very heavy. Under such conditions it is advisable

to work the coal in groups of eight or ten breasts each, as in district 5. The breasts are opened with a single chute and a manway, as shown. When the manway is driven as shown on the extreme right of district 8, it can be used as a chute, if necessary. Breasts with two chutes, similar to those in district 3, are also frequently opened up on very heavy pitches.

**1619.** In some cases it is advantageous to first drive the gangways to the limit before any of the breasts are opened, and to mine out the lift in sections, commencing at the inside end and robbing back the pillars.

**1620.** When a lift is greater than say 400 feet, a counter gangway parallel to the main gangway is driven from one of the rooms, from 250 to 300 feet on the pitch, above the main gangway, and rooms are opened from it. One of the old rooms is used as a chute to convey the coal to the lower gangway; and to avoid breakage, it is kept as full of coal as possible, or, if the inclination will permit, a self-acting incline is constructed in one of the rooms from the main gangway, down which the coal is lowered in the cars. Counter gangways are also sometimes made necessary by extensive rolls in the coal seam or by sudden and radical changes in the inclination of the seam.

---

#### METHODS OF OPENING AND WORKING BREASTS, CHAMBERS, OR ROOMS.

**1621.** There is considerable difference in the methods of opening rooms in anthracite and bituminous seams, owing to the differences in the physical characteristics of the seams, and the fact that anthracite coal will slide on chutes of less inclination than bituminous coal.

**1622.** In moderately thick coal seams pitching more than 4 degrees, and not more than 18 degrees, the rooms are usually driven across the pitch, thus securing a grade of track low enough to make easy the haulage of mine cars to the working face. When the pitch does not exceed 4 degrees, the rooms are turned off the gangway or level at right angles.

**1623.** There are two methods of mining the thick coal in breasts, when nearly flat :

1. The breasts are opened out and driven to the limit in the lower bench of coal, and the top benches are blown down afterwards, beginning at the face and working back.

2. When the roof is good and there is no danger of its falling and closing up the workings, the upper benches may be worked in the opposite direction, beginning at the gangway and driving towards the limit of the lift. When the seam is less than 12 feet, the top is supported by props; in thicker seams the expense is so great for propping that but little attempt is made to support the roof. In the thicker anthracite seams (notably the Mammoth) the coal in the breasts is so worked as to make an arch of the upper benches of coal, which acts as a temporary support for the roof, the coal in the arch being extracted when the pillars are robbed.

**1624.** Marked changes of dip may be so frequent that in a distance of from 300 to 600 feet nearly all the different modes of working breasts may be used. A breast may start on a very low pitch and the seam commence rising a few yards in, and the pitch may increase more and more until it becomes vertical. Or the reverse may be the case. The breast may start on a heavy pitch and gradually, or suddenly, become so flat as to necessitate the use of buggies, or small cars, to convey the coal from the face to the top of the pitch, down which the coal will slide in a chute.

**1625.** Fig. 497 shows a plan *A* and section *B* of a breast where the pitch becomes too steep for the mule to take the car up, and not steep enough for the coal to run or slide on sheet-iron chutes to the gangway. In the plan *A*, the roof is supposed to be removed from the coal and the reader looking down upon the bottom of the breast. The section *B* is laid along the line *bd*, and the reader is supposed to be looking towards the track in the breast. The coal is loaded into a small car or buggy *c*, and run down to the end of the tippie and delivered on a landing *l*, from



which it is loaded into the regular mine car. The refuse from the seam is used in building up the track, keeping it nearly level. When there is not sufficient refuse for this

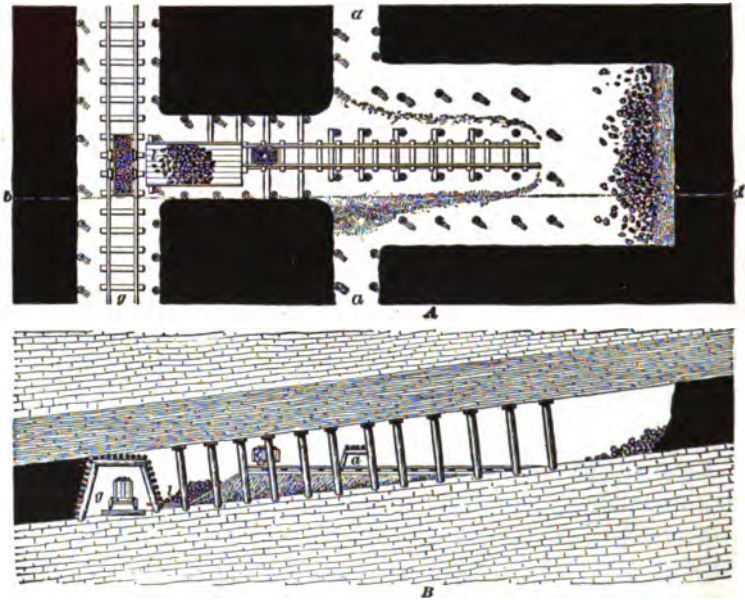

FIG. 497.

purpose, a timber trestle is used. The breast is turned off the heading *a* the full width and connected to the main gangway *g* by a narrow passage, as shown in the figure. This method is used in seams pitching between  $10^{\circ}$  and  $18^{\circ}$ .

**1626.** When the pitch of anthracite seams is from  $15^{\circ}$  to  $30^{\circ}$ , sheet iron is laid on the floor of the breast, and also in the loading chute, to facilitate the movement of the coal, but on pitches of less than  $18^{\circ}$  or  $20^{\circ}$  the coal will not move freely, and must be pushed down by the miner. When the pitch is greater than  $30^{\circ}$ , the coal will slide down without sheet iron.

**1627.** When the inclination of anthracite seams is less than  $30^{\circ}$ , the breasts may be opened with one chute in the

center, which ends in a platform projecting into the gangway, off which the coal can be readily loaded into the mine car. When this method is employed, the refuse is thrown to either side of the chute. If the pillars are to be robbed by skipping or slabbing one rib only, it is well to keep most of the refuse on one side. Sometimes, when the top is good, and the breasts are driven wide, two chutes are used, but the cost of making the second chute is considerable and is, therefore, not advisable unless necessitated by the method of ventilation employed.

**1628.** Fig. 498. In the plan *A* the roof is supposed to be removed from the coal and the reader looking down upon the breast. The section *B* is laid along the lines *h e* and *d b*.

The figure shows a method of opening a breast by two chutes *c, c*, when there is a great amount of refuse, or when a great amount of gas is given off. The chutes are extended, as the figure shows, up along the rib to within a few

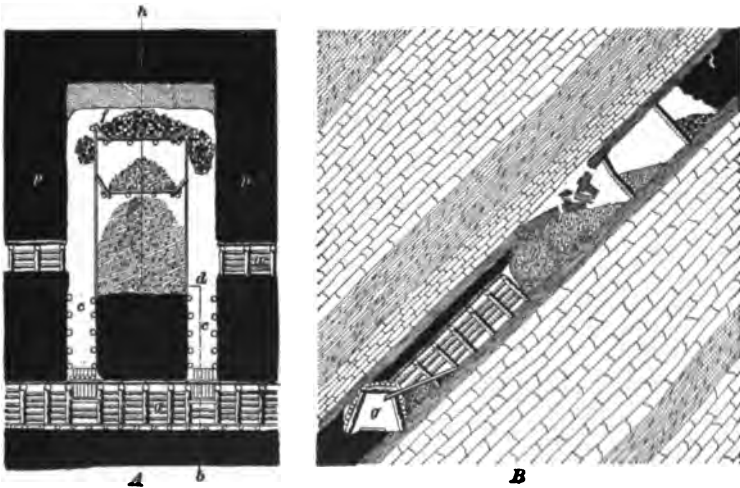

FIG. 498.

feet of the working face, either by planking carried on upright posts, or by building a jugular manway, so named because it is built of **jugulars** or inclined props, faced by

2-inch plank. It is made as nearly air-tight as possible, to carry the air from the heading *a* to the working face.

**1629.** The figure also shows a breast opened by this plan on a pitch too steep to enable the miner to keep up to the face. In seams of less than  $35^\circ$ , the platform *f* shown near the face of the breast is unnecessary, and in seams thicker than 12 feet it can not be built; hence, this method of working is applicable (1) to beds pitching more than  $35^\circ$ , and (2) to thin seams on heavy pitches.

The coal is separated from the refuse on the platform *f* and sent down the manway chutes, and the refuse is thrown in the middle of the breast behind the platform. A certain amount of coal is kept on the platform to deaden the blow from the falling coal.

The coal is run down the manway chutes and is loaded into the cars from a platform projecting into the gangway *g*. The chutes are timbered, but timbering is not erected unless the character of the coal requires it.

This plan can be employed in thick seams having a heavy dip, if there is enough refuse to fill the center of the breast so that the miner can work without the platform. The whole method is named **working on battery**.

**1630.** Fig. 499 is a section through *p p*, when jugulars *a, a* are used to form the manways *b, b* along the sides of

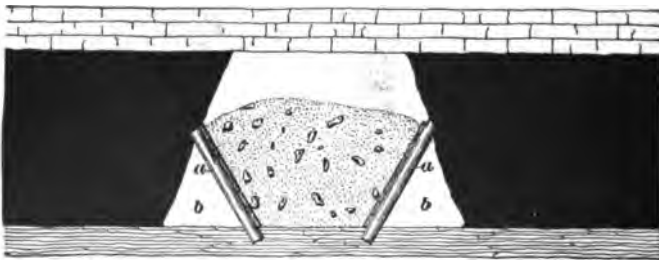

FIG. 499.

the breast, and Fig. 500 is a section through the same line when upright posts *a, a* are used to support the plank in

forming the manways *b, b*. The refuse *g*, in these cases, only partially fills the gob.

**1631.** In working very thick seams on heavy dips, where there is not enough refuse to fill the middle of the breast, the miner has nothing to stand on, the platform

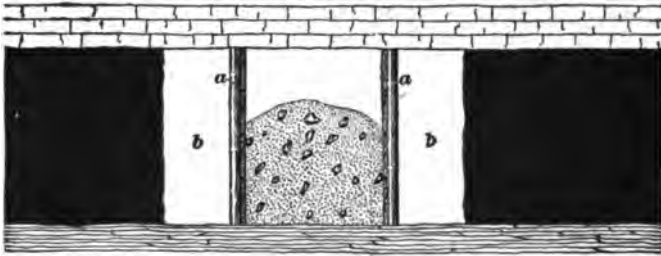

FIG. 500.

being impracticable; therefore, it is necessary to leave the loose coal in the breast, which involves the use of an entirely different mode of opening. Loose coal occupies from 50% to 90% more space than coal in the solid; therefore, when the coal is left in the middle of the breast, means must be supplied to draw off the surplus.

This surplus may be drawn out through a central chute with best results, because the movement takes place principally in the coal lying near the center of the breast. If the roof is poor, the movement of the coal will not in this way cause it to fall and mix with the coal; and, if the floor is soft, the jugulars, which are stepped into the floor, are not so liable to be unseated, closing the manway and blocking the ventilation. The surplus is sometimes sent down the manways, leaving the loose coal in the center of the breast undisturbed until the limit is reached.

**1632.** To prevent the coal from running out through the chutes, the opening into the breast is closed by a battery constructed by laying three, four, or five heavy logs across the openings, as shown at *b*, Fig. 501, or built on props as shown at *b*, Fig. 502; a hole is left in the center, or at one side of the battery, through which the coal may be drawn. The battery closes all of the openings into the

breast, except the space occupied by the jugular manways, and is made air-tight, or as nearly so as possible, by a covering of plank.

**1633.** Fig. 501 is a plan and section of a breast opened

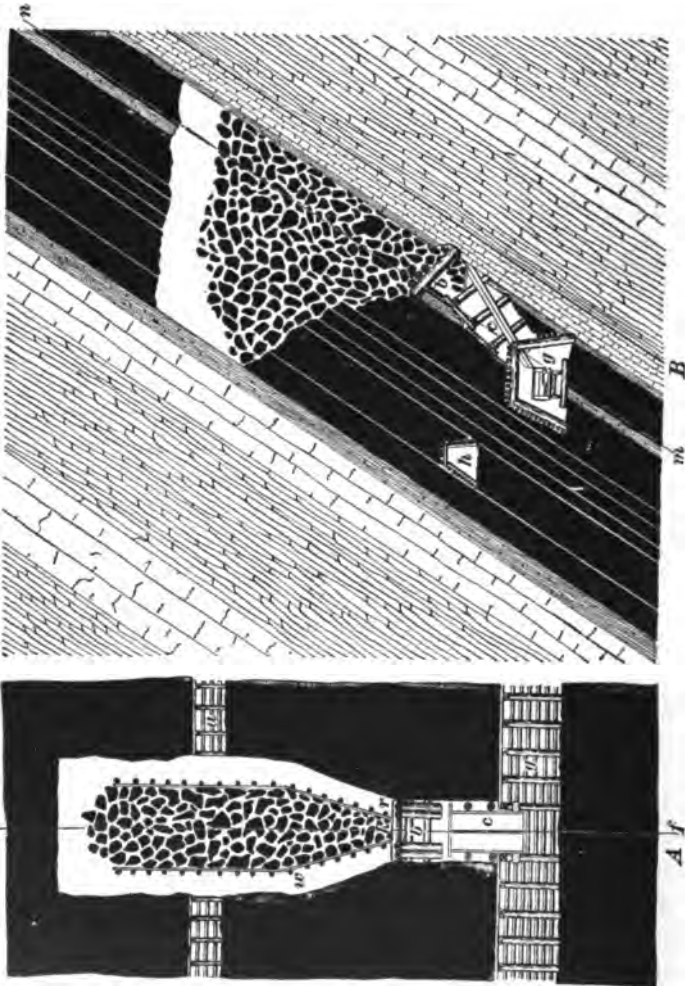

FIG. 501.

up by a single chute. The plan *A* is taken on the line *m n* shown on the section *B*, which section is taken on the line *f l* shown on the plan *A*. The pitch is great and the seam

is so thick that the breast must be kept full of loose coal for the men to work upon, the surplus being drawn off at the battery *b* and run into the car standing on the gangway *g* through the chute *c*. A manway *w* is made along each side of the breast, for the purpose of ventilation and affording a passage for the men to reach the working face. The heading *a* is used for an aircourse between breasts. The main airway *h* is driven over the gangway *g*, where it will be well protected.

By drawing the surplus coal through a central chute, the manways are not injured so much as when it is drawn off through side chutes, as the coal will move principally along the middle of the breast. When the breast is worked up to its limit, all the loose coal is run out of the breast and the drawing back of the pillars is commenced, unless for some purpose they are allowed to stand for a time.

**1634.** Fig. 502 shows a plan *A* and section *B* of double-chute breasts used in very thick seams having a heavy dip. The section *B* is made along the line *p q* on the plan *A*, and the plan *A* is made along the lines *r s* and *s t* on the section *B*. The breasts are entered by two main coal chutes *c, c*, each of which is provided with a battery *b*, through which the coal is drawn. A manway chute *m* is driven up through the middle of the pillar for a few yards, and is then branched in both directions until each branch (slant chute) intersects the foot of a breast near the battery *b*, as shown in the figure. The jugular manways *n, n* are started at this point and continued up each side of the breast. The main airway *h* is driven in the solid, through the stump *A* above the gangway.

**1635.** The figure also shows the main gangway *g* driven against the roof. By driving the main gangway against the roof, where the pitch is heavy, the loading chute *c* is more readily controlled, because the pitch of the chute is lessened.

When the main gangway is not driven against the roof, a gate is placed in the chute below the check-battery, which

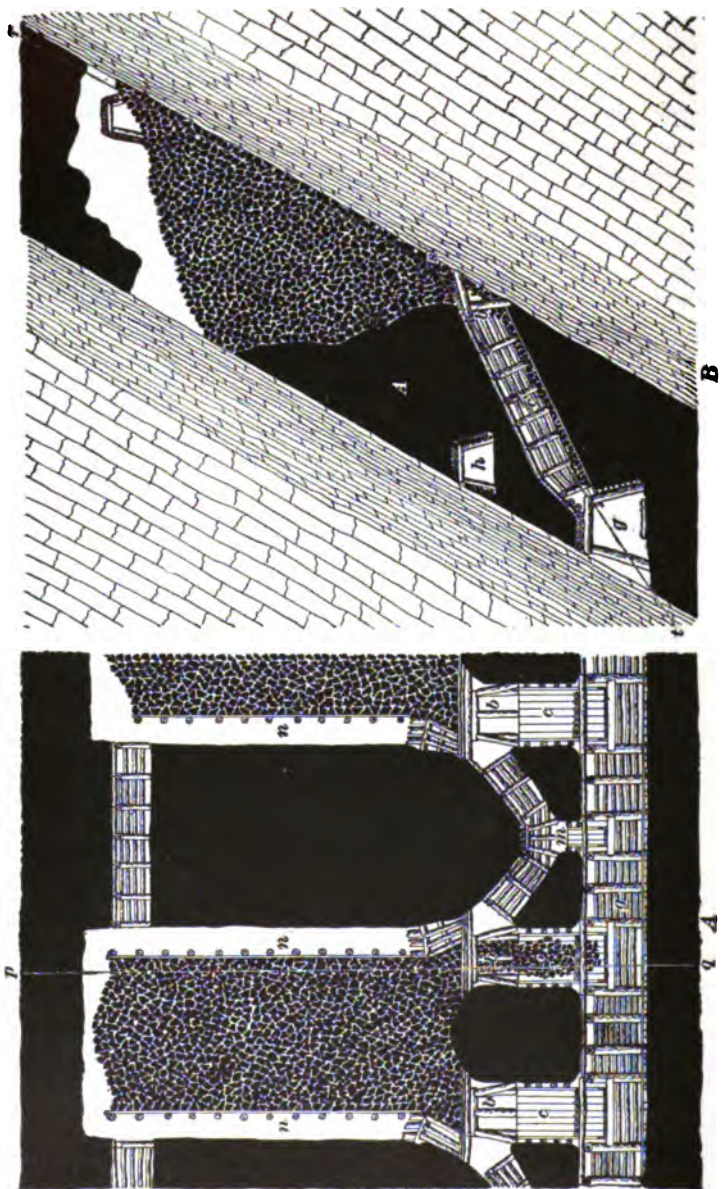

enables the loader to properly handle the coal. Coal in excess of the amount necessary to keep the miner up to the face may be drawn through the main battery, or sent down the manway chute, from which it is loaded through an air-tight check battery.

The main chutes are usually 8 or 9 feet wide, but sometimes only for the first 6 or 8 feet; above this they are driven about 6 feet square. The manway and *slant chutes* are also about 6 feet square.

**1636.** When the seam is not thick enough to carry the return airway *h*, Fig. 502, over the gangway, the chutes are driven up in the same manner as in Fig. 502, for a distance of about 30 feet, where they intersect the airway. The breast is opened out just above the airway, a battery being built in the airway immediately above each chute. A manway is driven from the gangway up through the middle of the stump until it intersects the airway, and a *trap-door* is placed at this point to confine the air. This manway is made about 4' × 6', or smaller.

**1637.** Fig. 503 shows a less complicated plan than Fig. 502. In this plan the main chutes *n, n*, are driven up to the heading *c*, from which the breast is opened out; a log battery is built at the top of each chute at the points marked *a a*. The chutes are used for drawing the battery coal, and for receiving the manway coal, and are also used for traveling ways.

In this case, and in the preceding cases, a check battery *b* is placed in the chute to prevent the air-current from taking a short cut from the gangway through the chute to the breast airways. This check battery is of great assistance to the loader when the chute has a very steep pitch, as he can readily control the flow of coal through the draw-hole.

**1638.** All of these methods are open to the objection that in case of any accident to the breast manway, by which the flow of air, shown by the arrows, is obstructed, there is no means of isolating the breast in which the accident occurs, and the ventilation of all the breasts beyond it is entirely stopped.



To overcome this, sometimes the pillar *A*, shown in left-

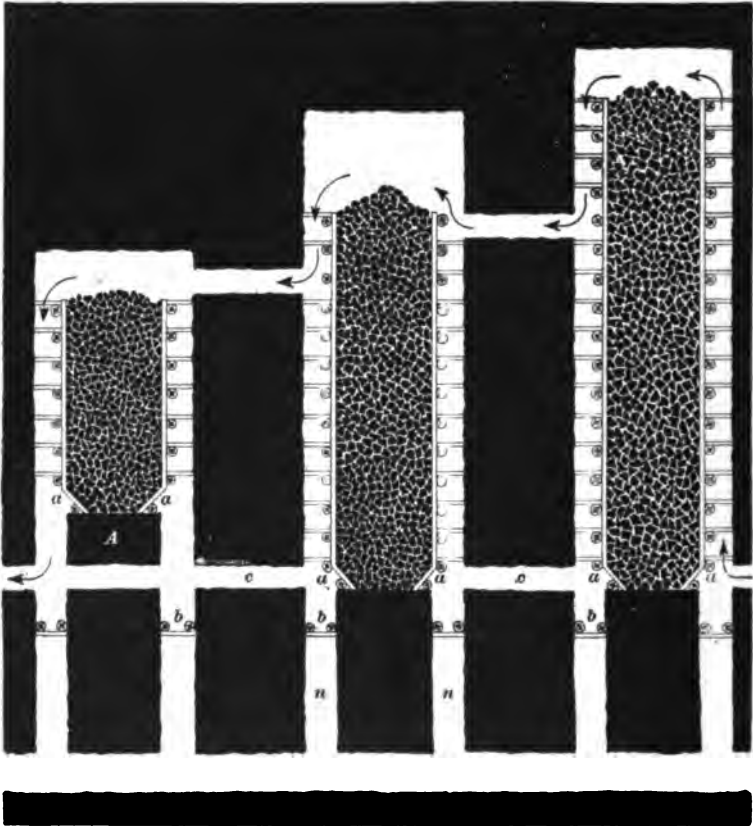

FIG. 503.

hand breast, Fig. 503, is left in each breast to protect the airway.

**1639.** Fig. 504 shows a plan *A* and section *B* of a breast worked in a seam sufficiently thick to have the airway *c* driven over the gangway *g*. The breasts are open by a chute  $9' \times 6'$ , driven up the pitch; or, if the gangway is driven along the top rock, in thick seams, the breast is opened by a chute driven across the seams a distance depending on the dip, but usually from 24 to 36 feet; the breast is then

gradually widened out to the proper width on both sides, as shown in the figure. The section is made on the lines *l k* and *i j*, and the plan is made through the lines *p q*, and therefore does not show the headings *c* and *d*. In the middle of each stump a small manway chute *m* is driven up a few yards, and then branches *s, s* are turned off in both directions until intersection is made with each breast. From the top of these manway-chutes, manways *w, w* are carried up on each side of the breast, as in other plans. It will be

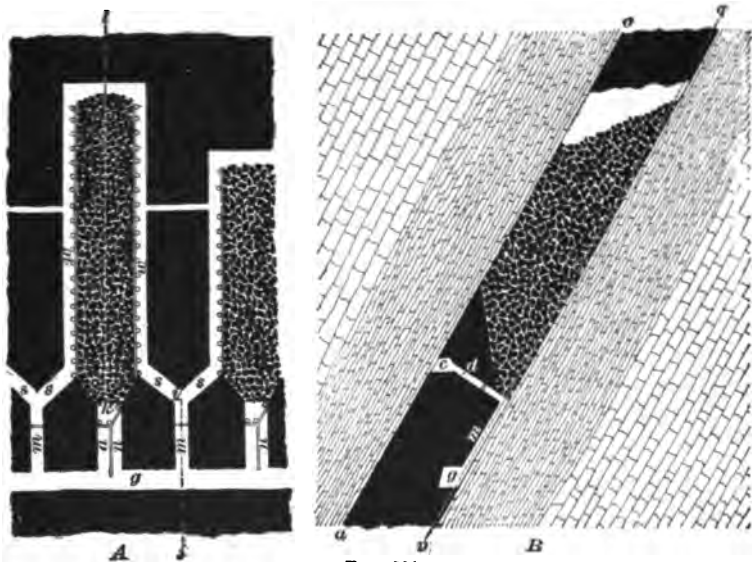

FIG. 504.

noticed in this case that the main chute *a* and battery have no connection with the slant and manway chutes *m*.

A narrow manway *n* is usually made by planking off a portion of the main chute so that the loader may have free access to the battery at all times.

When the pitch exceeds  $50^\circ$ , the gangway is sometimes driven in the top bench of the coal, which lessens the risk from a squeeze, and the chutes may be driven at an angle on which the coal will be most easily controlled.

This plan, however, is not frequently adopted, because it

incurs an extra cost in opening up the breasts by having to drive the chutes much further than is necessary when the gangway is driven along the bottom of the seam.

A small airway  $d$  is driven from the airway  $c$  to the manway chute  $m$ , but cross-cuts between the airway and gangway are also necessary where the headings are long and give off much gas while being driven.

The small airway  $d$  and the airway  $c$  are not used when the breast is working, but if any accident takes place in a breast manway by which the ventilation is blocked, the air can be conveyed around the breast through the airways  $d$  and  $c$  by simply removing the stoppings.

This plan is especially adapted to working thick, steep-pitching seams of soft, gaseous coal.

In many seams the gangways, levels, or stumps are drawn to the boundary before any pillars or stumps are drawn; and, in order to prevent a squeeze overrunning the stumps and pillars when they are being drawn, a strong pillar or block of coal 150 to 200 feet along the gangway and of the same length as the rooms is left at regular intervals of about 600 feet, a range of breasts being driven between the pillars thus left.

**1640.** Fig. 505 is a sectional view of a thick seam of coal standing vertically and mined by breast and pillar.

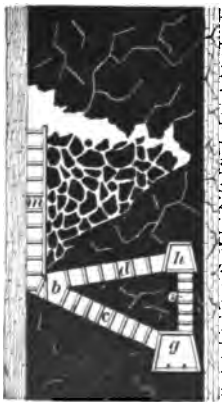

FIG. 505.

The lower part shows the arrangement of the gangway or level  $g$ , airway  $h$ , and chute  $c$ . The battery  $b$  is at the inner end of the chute and near the foot of the vertical manway  $m$ . The passages  $d$  and  $e$  are for the purpose of ventilation and affording easy access to the battery at the foot of the vertical manway.

**1641.** Fig. 506 is a profile of what is called a "back breast"  $p$  in the thick anthracite seams. The regular breast  $b$  having been mined out and probably abandoned, the coal over the main gangway  $g$  and monkey or air gangway  $k$  is worked by opening

a breast *p* off the monkey or other gangway driven in the coal, so that the coal may slide through chutes to the cars.



FIG. 506.

Such a mode of working may enable a large proportion of the gangway stumps to be removed, which otherwise would be entirely lost.

**1642.** Fig. 507 is intended to give some idea of the methods adopted in robbing or extracting pillars in steep-pitching thick beds of anthracite. It shows three worked-out breasts, *A*, *B*, and *C*, and the greater part of four pillars, with the bottom of a chain pillar just showing along the top of the cut. In *A* and *C* the manways remain, but they are supposed to be destroyed or removed in *B*. In order to get the coal out of the pillar on the left of *A*, the miner takes a "skip" off the side, and the figure shows a shot just fired and the coal falling down the old half-empty breast. This skip having been worked off, another is taken, and so on, as far as is safe or necessary until the pillar is gone, the miner retreating downwards as the work goes on, always keeping a manway open as a safe means of retreat to the heading

below. The pillar separating *A* and *B* will be worked away much in the same way. The pillar between *B* and *C* is shown as being taken out in a different way. A narrow chute or heading is driven right up the middle of it and cross-cuts put in right and left a few yards from the upper end. Into the middle of each square block of solid coal so formed, shots are put in as indicated by the white lines, and all fired

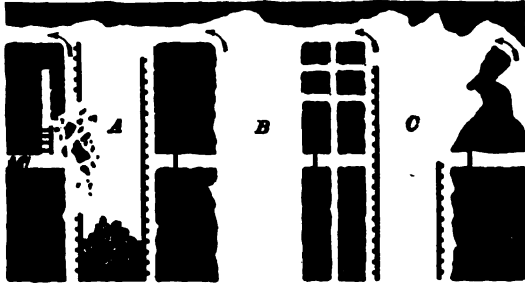

FIG. 507.

simultaneously by a battery. The operation is repeated in each descending portion of the pillar, unless, as sometimes happens (especially in very jointy or free seams), the pillar starts to run, which even a breast will often do under favorable conditions, so that scarcely any *mining* need be done after the gangways are driven, and the chutes started, and "batteries" formed. A case of the coal running of its own accord is sketched on the right of *C*.

#### ROCK-CHUTE AND TUNNEL MINING.

**1643.** Fig. 508 shows a section of two seams, separated by a few yards of rock, and worked on what is known as **rock-chute mining**. Chutes, from 4½ to 7 feet high and 7 to 12 feet wide, are driven in the rock from the gangway or level *g* to the level *l* in the seam above, at such an angle that the coal will gravitate from the upper seam into the gangway *g* driven in the lower seam. The working, otherwise, is similar to that previously described.

**1644.** Vol. AC of the Geological Survey of Pennsylvania says *rock-chute mining* contemplates a sequence of operation which may be summarized thus:

1. The opening of all gangways and airways in the lower seam, to develop coal as yet untouched, in a thick seam lying a few feet above it.

2. Developing the thick bed by a regular series of *rock chutes* driven from the gangway below; workings being opened out from chutes as in ordinary pillar and breast working—the panel system or some other plan may be found better than pillar and breast workings.

3. Driving the breasts to the limit of the lift and robbing



FIG. 508.

out the pillars from a group of breasts as soon as possible, even if a localized crush is induced.

4. After one group of breasts is taken out and the roof has settled, opening a second series of chutes for the recovery of coal from any large pillars that were not taken out when the crush closed the workings.

5. While the work of recovering the pillar coal is in progress, a second group of breasts may be worked, and the process continued until all the area to be worked from that gangway has been exhausted. The same process is employed in opening lower lifts.

6. When all the upper bed of coal has been exhausted, the lower seam may be worked by the ordinary method. Workings in this seam may be carried on simultaneously with the upper bed, but to avoid the possibility of a squeeze destroying these workings, very large pillars must be left. After exhausting the upper seam, these pillars may be advantageously worked by opening one or two breasts in the center of each, and when these are worked to the upper limit, attacking the thin rib on each side, commencing at the top and drawing back.

When the roof of the lower bed is good, the cost of timbering and keeping open the gangways and airways will be considerably less than if these were driven in the upper seam, and this difference, in some cases, may be sufficient to pay for driving all the rock chutes.

**1645.** There are three undetermined points in this connection, viz.: 1. The maximum distance between the two beds, or the length of rock chute that can be driven with satisfactory financial results. 2. The maximum dip on which such working can be successfully opened. 3. The maximum thickness of the upper and also of the lower seam, which will yield results warranting the additional outlay when the rock chutes are of considerable length.

**1646.** Fig. 509 shows how one or more seams are worked by connecting them by a "stone drift," or "tunnel," driven horizontally across the measures, through which the coal from the adjacent seams is taken to the haulage way leading to the landing at the foot of the slope or shaft. Tunnels are sometimes driven horizontally through the measures from the surface, so as to cut one or more seams above water level.

The lower seam of coal is worked from a gangway or level *l*, connected by a "tunnel," or "stone drift" *t*, to the level or gangway *g*, in the thick seam. The "stone drift" may be extended right and left to open seams above and below the thick seam. This "tunnel," or "stone drift," is never driven under a breast in the upper seam, but directly under the middle of the pillar.

In the upper and thicker seam, when the coal is very hard, a breast *b* is worked to the limit and the loose coal nearly all run out through the chute *s* into the gangway *g*. The "monkey gangway" *m* is driven near the top as a return airway, and is connected to the upper end of the

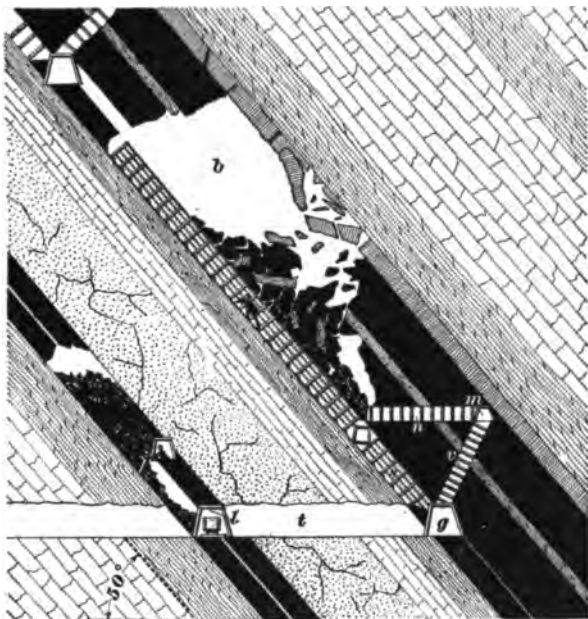

FIG. 509.

chute *s* by a level heading *n*, and to the main gangway *g* by a heading *v*. These headings are driven for the purpose of ventilation and to provide access to the battery in case the chute *s* should be closed. In the lower seam the breast is still being worked upwards in the ordinary manner.

#### WORKING CONTIGUOUS SEAMS.

**1647.** Fig. 510 shows the method of working twin seams separated by a few feet of slate or rock. This probably suggested the rock-chute method shown in Fig. 508.

To the right of the figure, the seams are quite flat and are worked by running the car *c* from the level *l* into the



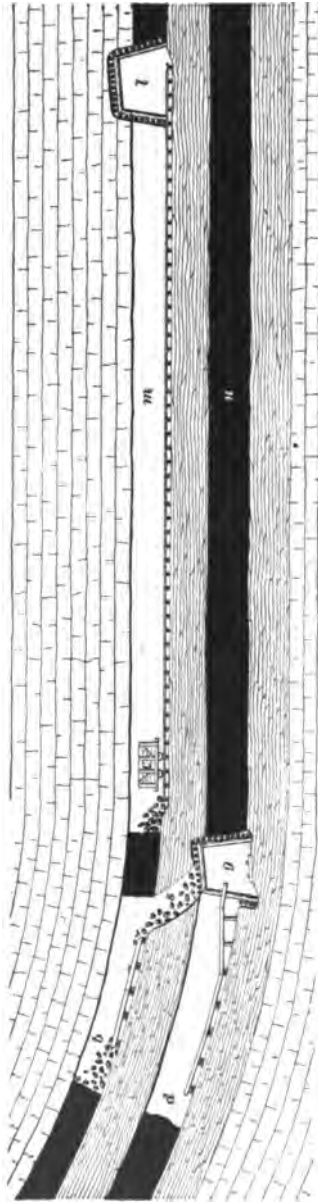

FIG. 510.

breasts; while to the left of the figure the seams begin to pitch rapidly and the breasts are worked by chutes, and one vertically over the other. The coal in the breast *b* is conveyed to the gangway *g* by means of a rock chute *s*, necessitating but one gangway for both seams. The breast *d* is shown with all the loose coal run out in cars on the gangway and taken away.

**1648.** Twin seams are usually worked together until the parting becomes 4 feet or more in thickness, after which it is best to work them separately.

Split seams, or seams lying close together, are mined by first working the lower seam to the limit and then dropping the parting and mining the upper seam outwards. In some of the flatter seams the upper seam is mined by dropping the parting and taking down the upper coal, keeping its face a short distance behind that of the lower seam.

**1649.** When there are several seams to be worked in the same field by the pillar method, the upper seam

should be worked first. This does not mean that no work can be done on the lower seams until the upper one is mined out, but means that the pillars of the lower seams must not be drawn until the upper seam has been worked out, unless there is a great thickness of rock between the seams which would entirely fill the gob and choke before the draw or subsidence reaches and damages the upper seam.

### BARRIER PILLARS.

**1650.** **Barrier pillars** are large pillars left between the workings of adjoining mines. They may run lengthwise with the strike of the seam when one mine is below the other, and then they are simply large chain pillars. More frequently, they run parallel with the pitch, and separate two mines located side by side. Barrier pillars are formed by each mine leaving one-half the required thickness on each side of the boundary line.

**1651.** For finding the width of barrier pillars in anthracite seams, the following formula, adopted conjointly by the chief mining engineers of four of the leading anthracite companies and the State Mine Inspectors, is recommended:

Minimum thickness of barrier pillar = (thickness of workings multiplied by 1% of depth below drainage level) + (thickness of workings multiplied by 5).

Thus, for a seam 6 feet thick, 500 feet below drainage level, the minimum barrier pillar should be  $(6 \times 5) + (6 \times 5) = 60$  feet.

As the crushing load of an average bituminous coal is only about one-half that of anthracite, the formula given above can be used to determine the minimum thickness of a barrier pillar in a bituminous seam by simply doubling the result. Thus, in a bituminous seam of average hardness, 5 feet thick, and 400 feet below the drainage level, the barrier pillar should be  $\{(5 \times 4) + (5 \times 5)\} \times 2 = 90$  feet.

**1652.** Good judgment must be used in determining the size of barrier pillars in bituminous seams, owing to their

varying degrees of hardness. For very soft coal, the pillar must be larger than for a firm, hard coal under the same conditions. When the barrier pillar is formed on the strike of the seam, it should be larger than when formed on the dip. It is impossible to formulate a rule to meet all conditions. The rules given are merely for general guidance. They will usually be found safe for determining the minimum thickness of the pillar required.

### APPROACHING ABANDONED WORKINGS.

**1653.** Under all circumstances, in openings approaching old workings in which gas or water under pressure is likely to be encountered, special precautions must be taken. Accurate surveys and maps, while of great value as guides, should not be relied upon entirely. The opening approaching the old workings should not be over 12 feet wide, and bore-holes should be kept at least 20 feet in advance of the face. There should be one bore-hole in the center of the face running in direct line with the opening, and at every 8 feet of advancement of the face, flank-holes should be put in on each side. These flank-holes should deflect from the line of the opening from  $25^{\circ}$  to  $30^{\circ}$ , as shown by Fig. 511. When the seam is very thick, two or more sets of holes, one above the other, should be put in. All men engaged in this work should carefully watch for all symptoms of an increase of

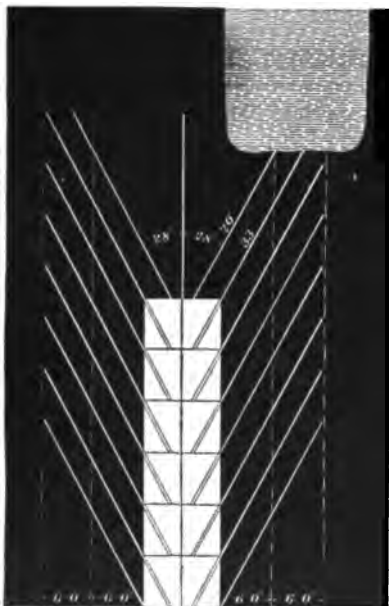

FIG. 511.

side. These flank-holes should deflect from the line of the opening from  $25^{\circ}$  to  $30^{\circ}$ , as shown by Fig. 511. When the seam is very thick, two or more sets of holes, one above the other, should be put in. All men engaged in this work should carefully watch for all symptoms of an increase of

water or gas, and plugs should be kept handy, to stop up the holes in case water or gas is struck. Only safety lamps should be used at the face. In no case should more than one opening be driven towards old workings containing water or gas. In pitching seams, when the relative elevations of both the old workings and the new are approximately known, flank bore holes are necessary on one side only. When the seam has a very heavy pitch and the coal is free, much longer holes are necessary to ensure safety.

### PROPPING.

#### POSITION OF PROPS.

**1654.** The tendency of the roof is to fall in the direction of the force of gravity, in the line  $b g$  (Fig. 512). But where the roof is solid and holds together, like that in

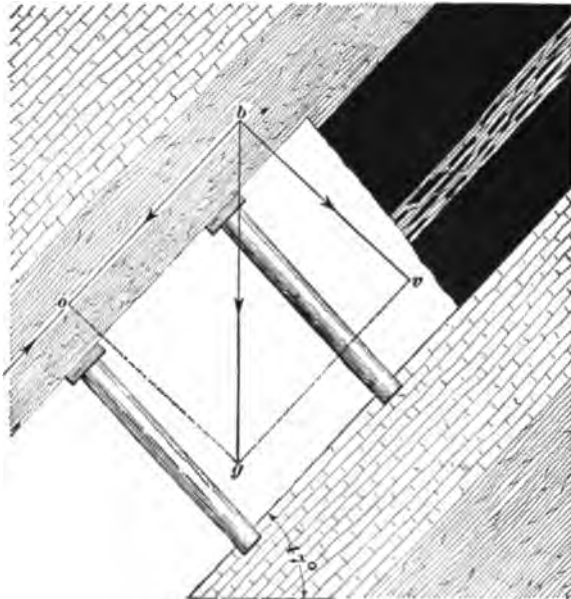

FIG. 512.

Fig. 512, this force of gravitation, represented by line  $b g$ , is resolved into two forces, represented by the line  $b o$ , parallel to the dip of the seam, and the line  $b v$ , at right angles

to the dip. As the line  $bo$  is equalized by an opposing force inherent in the roof itself, the only force or pressure to be provided against is that represented by  $bv$ ; and as the resisting force of the floor is greatest in a direction at right angles to its inclination, it follows that the most effectual position for posts and all props to support the roof is at right angles to the dip of the seam.

**1655.** It will be noticed by comparing Figs. 512 and 513 that the force represented by the line  $bg$  is constant, being due to gravity, and that the force represented by the line  $bv$ , which represents the component of the force  $bg$ ,

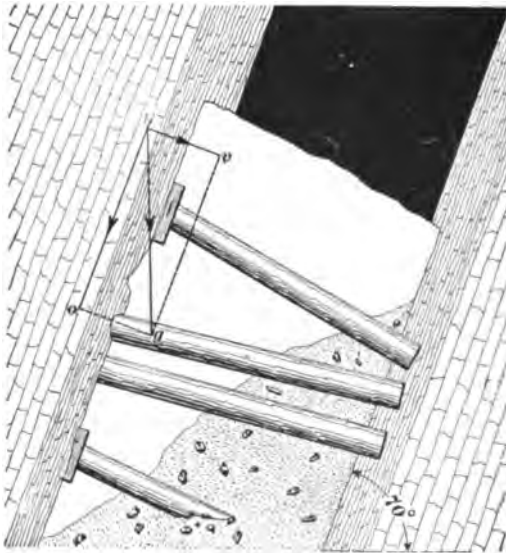

FIG. 518.

acting perpendicularly to the seam, varies inversely as the inclination. From this it is clear that, the greater the inclination, the less the weight upon the props.

In practice, posts are not set at right angles to the pitch, but are slightly inclined up the pitch so that they will tighten if any sliding of the roof takes place.

**1656.** The following table shows the maximum and minimum angles at which props should be set on varying inclinations :

Dip of Seam.	*Underset at Prop.	
	Minimum.	Maximum.
6°	0°	1°
12°	0°	2°
18°	1°	3°
24°	1°	4°
30°	2°	5°
36°	2°	6°
42°	2°	7°
48°	3°	8°
54° and upwards.	3°	9°

\* Underset means that the head of the prop leans up the pitch, and the angles given show the deflection from a line at right angles to the floor.

**SETTING PROPS.**

**1657.** Props in some districts are invariably set with the thick end upwards. In respect to efficiency, one end is as well upwards as the other, as resistance equals pressure, and the strength of the post corresponds to its thinnest sectional area. By placing the thinnest end of posts in the floor, a smaller foot-hole is required, which will consequently take less time to cut out. Being more solid and stronger at their thick ends, props, when being set, are better able to bear the blows on their head when set with the thick end upwards. Some managers set the thick end down, while others set the larger end against the weakest stratum, be it top or bottom.

**1658.** Props for thick seams are usually rounded at the bottom to fit the foot-hole cut in the floor. Props are rounded in heaving bottoms to prevent their "mopping," i. e., being splintered at the bottom.

In seams of moderate inclination, where the bottom and top are both hard, props are set on foot-pieces which are placed on some loose material which acts as a cushion for the prop until the weight is uniformly distributed over the props. If one prop is tight to the top and bottom, while the others are only moderately so, the tight prop must "mop" or give way. Props should be set from the rise, i. e., the foot of the prop should be placed in position with the head up the pitch, from which position the head of the prop is raised to the roof.

**1659.** In many cases there is very little pressure on mine props in the first working, while in others a heavy weight will be noticed in a few days by the weaker props giving way in their weakest part. Where the top is fairly strong only a single prop and cap is needed; but, where the top is loose and jointy, either cross-bars or long, strong caps are required. Cap-pieces for wedging posts tightly to the top and bottom are indispensable. They extend the supporting area if they are thick enough and extend beyond the prop. They are, also, of great value as cushions, into which the prop can squeeze when weighted; hence, the post lasts longer without cracking or bending.

---

## **GANGWAYS, LEVELS, HEADINGS, OR ENTRIES.**

---

### **MAIN ROADS.**

**1660.** In inclined seams of considerable thickness, levels can be driven any height, but in the thinner coals the height is determined by the thickness of the seam. Gangways in the anthracite district of Pennsylvania are generally 6 or 7 feet high, clear of the rail, and from 10 to 12 feet wide. In soft-coal mines, the height is variable; the haulways where mules are used are seldom less than 5½ feet and are sometimes 9 feet high, and their width varies from 8 to 12 feet.

**1661.** Some managers prefer that the main roads driven from the shaft bottom or slope landing shall follow the strike of the seam in all its variations, allowing sufficient rise (1 in 200 to 1 in 100) for drainage. This necessarily makes a

very crooked and undesirable road for the application, in the future, of mechanical haulage, although it may be advantageous for the limited use of mule haulage. The application of mechanical haulage should be considered when making a new opening. This would imply that all haulage roads should be as straight as possible, care being taken to avoid even small curves. In many mines the headings are driven on line. "Sights," or plugs with nails in them, from which plumb lines are hung, are placed in line in the roof, near one side, so that the passage of mine cars does not interfere with them.

The grade of the haulage road should be kept uniform throughout by cutting through small irregularities in top and bottom. The little expense incurred will be amply rewarded by the smoothness and rapidity of the haulage of the coal. Where the seam is flat, there may be a great many irregularities, such as local swamps, faults, etc., which render it out of the question to maintain a regular grade throughout. In such cases, the grade should be made uniform between certain points. A road may, in some mines, have many different grades which will not be very objectionable if the road is straight—only a few pounds more of steam are involved, if mechanical haulage is used. Crooked roads soon wear out ropes or chains. In some coal mines where large quantities of gas are given off, large airways—gangways, levels, headings, entries, aircourses, etc.—are required. With a weak top these are best secured by increasing the height, but in case of a strong top, extra width may be taken from the sides.

#### TIMBERING LEVELS.

**1662.** In flat seams, the manner of timbering entries, etc., is pretty much as described for drifts, while in pitching seams, different forms of timbering are resorted to. Much depends upon the angle of dip and the thickness of the seam. Round timber, being so much stronger and requiring less preparation for use than square timber, is generally used in timbering levels. The timber used in



gangways is usually from 9 to 15 inches in diameter. One great difficulty in timbering is found in the fact that timber too small is frequently used. Often, where 15-inch timber is really required, 10 to 12-inch timber is used. The angle between the legs and collar depends upon the method of timbering. However, the legs usually incline inwards 3 or 4 inches to the foot. The kind of timber used will depend largely upon the locality in which the mine is situated. Oak, chestnut, hemlock, cedar, and spruce are largely used.

**1663.** Fig. 514 shows the method of timbering the levels in thin pitching seams. The airway is driven on the dip side, and is, therefore, also used as the watercourse. The top is supposed to be weak. The legs *l, l* and the col-

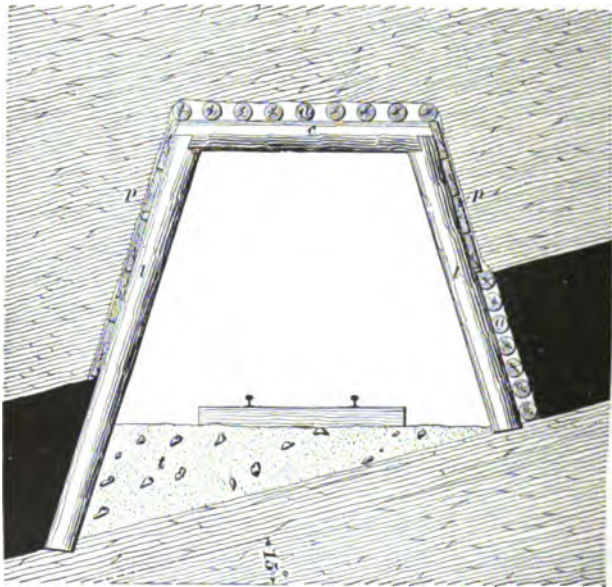

FIG. 514.

lar *c* are made of round timber about 12 inches in diameter, and are so jointed together that the collar *c* will stand great pressure. The laggings *a, a* are round poles taken direct from the woods, and are usually from 3 to 6 inches in diam-

eter. They are used to keep the loose coal and roof from falling between the sets of timbers, which are from 3 to 5 feet apart. Where the lateral pressure is slight, planks *p, p* are used. The road is made level by filling in the low side with refuse *t*, as shown in the figure.

**1664.** Fig. 515 shows the arrangement when the top is hard. If the seam were 4 feet thick, it would not be

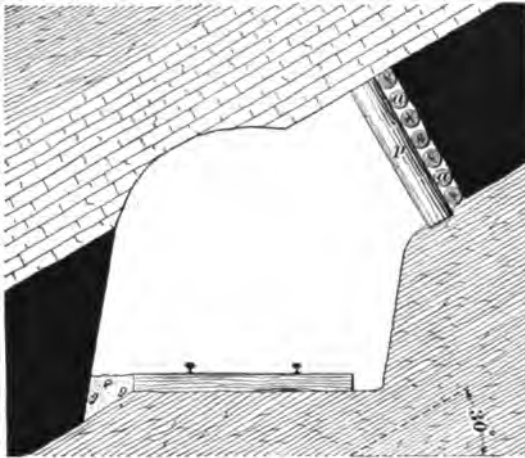

FIG. 515.

necessary to break into the top. When the bottom is soft and too much of it is taken up, there may be trouble in keeping the rise side of the road in good condition. The post *p* is simply used to support the laggings *a, a*.

**1665.** Fig. 516 shows a level in a seam of moderate thickness with a fairly good top. When the mine produces a great deal of gas, it is necessary to have gangways of large sectional areas in order to get an adequate supply of air. This is accomplished in low seams by driving the levels wide and placing the road to one side, and setting posts near it to support the roof, as shown in Fig. 516, in which case it will be noticed that the post *p* is set vertically with a good hold in the roof.

**1666.** Fig. 517 shows the "Post and Bar System." It

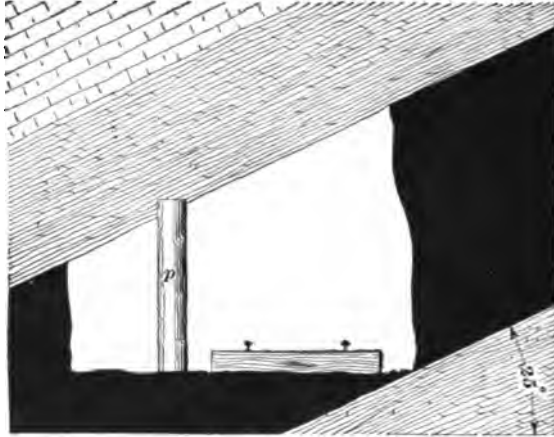

FIG. 516.

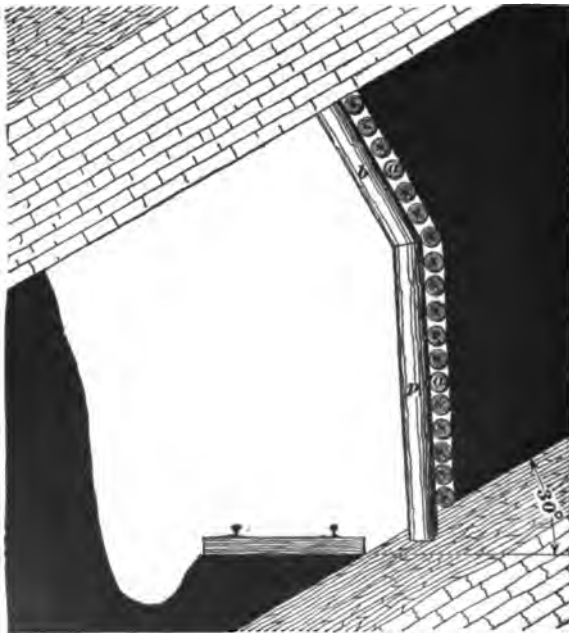

FIG. 517.

is open to many objections. The jointing of the post *p* and bar *b* is necessarily weak, but where the pressure upon the

laggings  $a$ ,  $a$  is not very great it may be convenient. The roof is supposed to be strong.

**1667.** Fig. 518 shows the timbering used in thick seams of frail coal with a tender roof. Both legs  $l$ ,  $l$  are the same

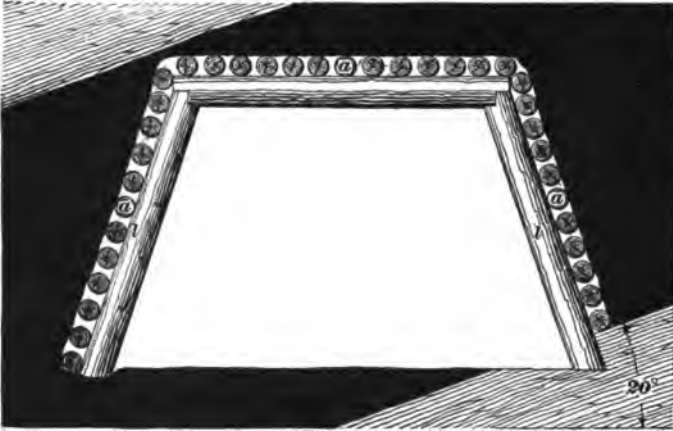

FIG. 518.

length, and laggings  $a$ ,  $a$  are placed all around the set of timber.

**1668.** When the coal is very firm but the roof tender,

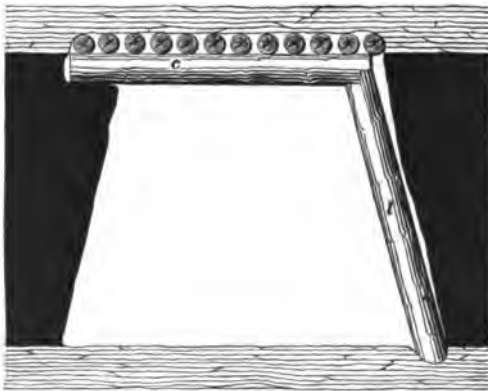

FIG. 519.

one leg of the timber may be left out, as Fig. 519 shows.

In some cases both legs can be dispensed with. Whether the collar *c* can be used alone or one end of it supported by a leg *l* can be determined by the relative cost of forming the holes in the top of the seam, so as to get the collar in place, and of setting and supplying the leg.

**1669.** Fig. 520 shows the method of timbering when the angle of dip is great, the bottom hard, and the seam is not thick enough to give full height for the entry. This

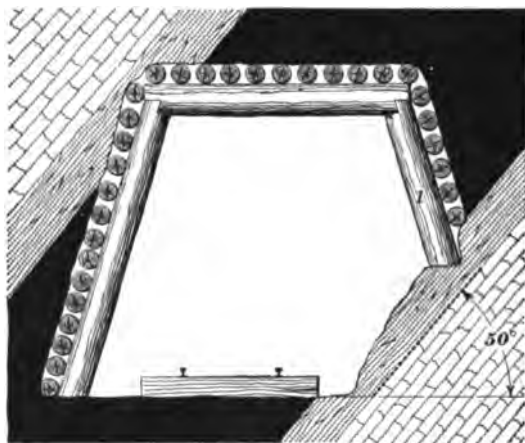

FIG. 520.

method very much reduces the cost of taking out enough rock to get in a set of timber having equal legs. The shorter leg *l* is given a firm hold on the rock bottom. The set of timber resembles that of Fig. 518.

**1670.** Fig. 521 shows a form of timbering used in pitching seams where the coal is soft, and falls to a height greater than that required for the gangway. The leg *l* on the high side is made long enough to reach up to the roof to support the laggings *a, a*, which keep the soft coal from continually sliding down into the gangway. The collar *c* strengthens the leg *l*. The coal is allowed to fall off on the low side where no lagging is necessary.

**1671.** Fig. 522 shows a method of timbering a level when the conditions are nearly similar to those in Fig. 520.

The inclination, however, is greater, and the top and bottom harder. The leg *l* is given a good hold in the bottom so that it will not be pushed out by the pressure of the coal.

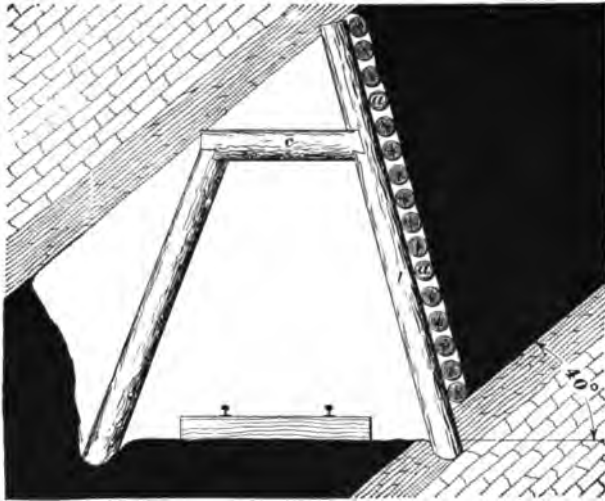

FIG. 521.

It will be observed that in this case the pitch is so great that the bottom on the high side is not disturbed, and the

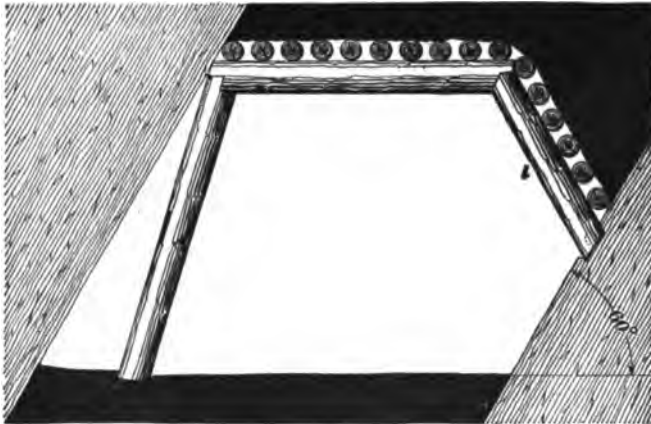

FIG. 522.

coal on the low side is allowed to fall away from the roof, as in Fig. 521.

**1672.** When the side pressure is great, the power of



FIG. 523.

resistance is much increased by placing a second horizontal piece *a* between the two legs *l*, *l*, as shown in Fig. 523. This

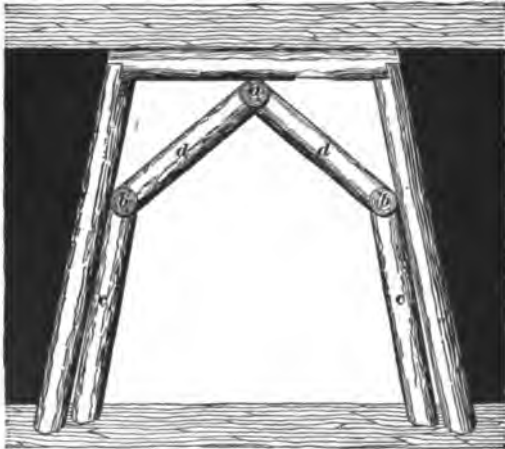

FIG. 524.

prevents the lateral pressure from splitting the legs at their upper ends.

**1673.** Figs. 524 and 525 show forms of timbering capable of resisting enormous pressure. The operation of fixing the braces inside the regular set of timbers is as follows: The longitudinal timbers *a, a*, immediately under the cap or collar, are put in place and temporarily held there by pieces of wire. The length of each piece is about 10 feet. Next to the two sides, longitudinal pieces *b, b* are placed and

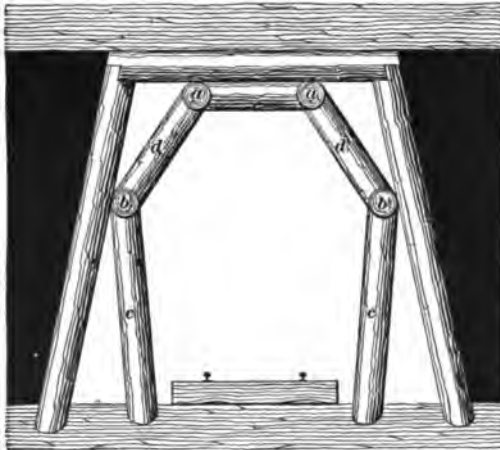

FIG. 525.

temporarily held in position also by pieces of wire. Two or three struts *c, c* are then placed under the side longitudinals, and afterwards some of the upper struts *d, d* are inserted obliquely and driven towards their permanent positions. The wires are now removed, and the remaining struts are driven firmly into their places. The lower ends of the struts *c, c*, Fig. 525, are set away from the timbers for the purpose of further strengthening the resistance to lateral pressure.

## UNDERGROUND ROADS.

### TRACK LAYING.

**1674.** Good solid roads are essential features of a well-managed mine. It is difficult to get a large tonnage of coal over poor tracks, and the damage to cars, etc., is such an item of expense that this one consideration of good tracks may decide whether or not the operation will be a financial



success. The weight of the rail, width of the gauge, the nature and shape of the switches, etc., depend on (1) the size of the mine car, and (2) the method of hauling. High speeds require heavy rails, solid roadbeds, and specially devised switches. The rails should be in good alinement, and the ties should be carefully bedded so that they will be solid and not allow the rail to yield under the load. Ties are best made of oak, which is durable and takes a tenacious hold upon the spikes which are driven into it to secure the rail. Ties are usually from 4 to 6 inches deep and 6 to 8 inches wide, and are generally placed from 18 to 30 inches apart, from center to center.

**1675. Gauge.**—In Great Britain, the gauge in most general use is 24 inches, but variations from 18 to 30 inches are frequently employed. In America the variation is greater, the gauge ranging from 30 inches to 4 feet 8½ inches. It is generally admitted that a gauge of more than 4 feet can but seldom be economically employed, and one less than 30 inches is undesirable. The gauges in most common use are 30, 33, 36, 42, 45, and 48 inches, but other intermediate gauges are used. It is claimed that the greater stability of wide gauges reduces the expense, because the capacity of the car is increased, the outlay for rolling stock is reduced, as is also the cost of repairs. Again, it is claimed for the narrow gauge that the ease of hauling around sharp curves, the reduction in cost of construction, and the use of mine cars with inside wheels are advantages greater than those advanced for the broad gauge.

The height of the seam and the nature of the roof are factors that enter largely into the determination of the gauge.

**1676. Rails.**—Wooden rails are now only used in room-roads, and even there they are frequently covered with strap-iron if not replaced by light steel T rail. Iron T rails are falling rapidly into disuse. Steel T rails are manufactured in America for mine use in sizes varying from 8 to 45 pounds or more per yard of their length. Where the cars

do not carry over 2,000 pounds and mule haulage is in vogue, the size used generally is 12 to 30-pound steel T rail, but for heavy loads or great speeds the size varies from 30 to 45 pounds. The 8-pound rail is only used in rooms, and where there is little traffic.

On steep roads, where the cars must be lowered by hand, i. e., by brake, or sprags, a wooden rail is laid close alongside the T rail to increase the friction.

Rails are manufactured in irregular lengths, generally from 12 to 30 feet, and when laid on heavy inclines they are always joined together by fish-plates; but on level roads, with good, hardwood ties, fish-plates are seldom necessary to keep the rails well butted together if the rails are of the right weight.

In America the T rail is spiked directly to the ties by hook-spikes *d, d*, Fig. 526. In Great Britain and elsewhere, the base of the rail has a hole punched, or a notch cut, in the side to receive the hook-spike. This, they claim, prevents longitudinal movement.

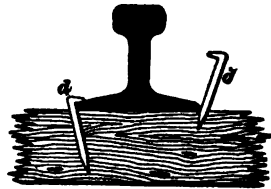

FIG. 526.

Both spikes on the inside of the road should be driven in the same side of the tie, and those on the outside of the rail in the other side of the tie, in order to keep the ties square across the road.

#### SWITCHES.

**1677.** The switches used in coal mines are somewhat different from those used on the surface. It is of great importance that they be made as strong and as simple as possible so as to require but little attention from the drivers.

Switches used on the main haulage roads are quite similar to those used on railroads, while those used in the productive branch roads are usually made with no movable parts. A description of the most common ones in use will now be given.

**1678.** Fig. 527 shows a switch used in low seams where the car is delivered on the main track by hand. The tongue

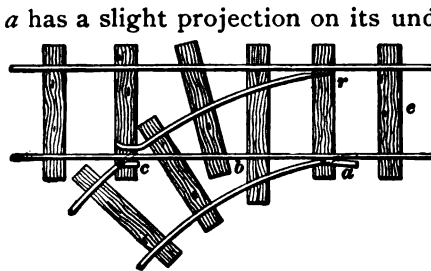

FIG. 527.

*a* has a slight projection on its under side to prevent it slipping off the rail *b* until raised by hand. The one objection is that if the tongue is not laid off the rail before the trip passes, it will derail the whole trip. The cross-latch *c* must be removed by hand also.

The tongue *a* should be set sufficiently far in advance of the point *r* so that, when the car is approaching the switch from the point *e*, the wheel will have run up the latch *a* far enough to raise its flange above the rail *b* before the wheel on the other side strikes the point *r*. When the car is to be taken over the switch, the latches *a* and *c* are put in the position indicated by the dotted lines, and the car, as it approaches the switch, is given a shove so that the flange of the wheel will pass inside the point *r*, and the car be sure to take the switch-track. This switch has the advantage of leaving a straight, unbroken line of rails for the main road which does not need to be relaid when the switch is taken out, and, further, full-length rails need not be cut to suit the switch, thus saving much waste of good rails.

**1679.** Fig. 528 shows a switch with a cast-iron frog *f*, and fixed points *a* and *b*. It is used principally in butt headings where the car carries a heavy load. The advantage of this kind of a switch is that it has no adjustable pieces about it, and consequently requires no attention from the driver.

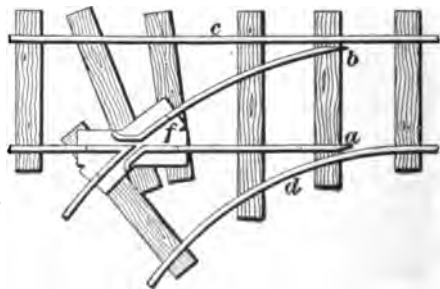

FIG. 528.

The difficulty with this switch is that the flange of the wheel is liable to catch the point *b*, while the car is running along the straight road,

and either derail the car or cause it to run in the switch. This, however, can usually be avoided by making the rail *c* somewhat lower than the rail *a*, thus causing the car while passing to cling to the rail *c*, and readily pass between the point *b* and the rail *c*, and at the same time causing the wheel on the opposite side to take the rail *a*. Another great trouble experienced with this kind of a switch is that where the wheels are allowed to remain on the cars after grooves have been worn in their treads, the wheel will invariably follow the rail *d*. The point *b* should be higher than the rail *c*, so that the tread of the wheel will not strike the rail *c* while the car is leaving the switch; similarly, the point *a* should be higher than the rail *d*, so that the tread of the wheel will not strike the rail *d* while the car is running along the straight road in the direction from *f* to *a*. The rail *c* being lower than the rail *a*, it is obvious that when a car is to be taken in the switch, the driver will have to push the car towards the rail *d* so that the wheel will take the rail *b*, and the flange of the wheel on the opposite side will pass between the point *a* and the rail *d*.

This form of switch is not applicable in the case of mechanical haulage, because it does not give an unbroken main line, which is essential to the steady movement of the trip.

**1680.** In laying a switch great care should be taken regarding the relative heights of the lead and follower rails. Where the switch is laid to the dip side of the heading, and the loaded cars must be pulled from the dip over the switch, the follower or inside rail should be the higher; while in the case where the switch is laid to the rise side of the heading and the loaded cars will run over it, the lead rail should be the higher.

**1681.** When the switch is not to be in constant use, a latch *c*, Fig. 529, is used instead of a frog. The switch shown in Fig. 529 is open to the charge of making a broken main road, but it is not liable to derail loaded cars, as the latches will be adjusted by the cars when traveling

outwards, if the speed is not great. When this form of switch is used for a turnout, the lead rail *a* is made about

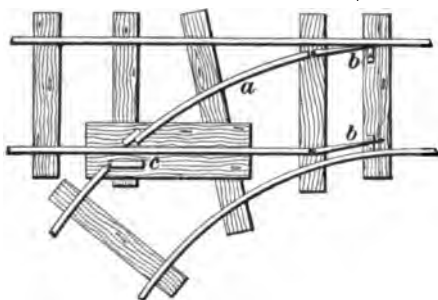

FIG. 529.

double the length of that used for a room. The length of the lead rail is determined in all cases by the radius of the curve where the switch is to be laid.

The tongues *b, b* are sometimes connected by a rod attached to a lever, so that they may both be moved at once from the side of the track, or by a person stationed some distance away. Where the traffic is all in one direction, as in turnouts, the tongues are kept in one position by a spring-pole spiked alongside of the track.

**1682.** Fig. 530 shows a double switch sometimes used in some parts of the anthracite coal fields of Pennsylvania.

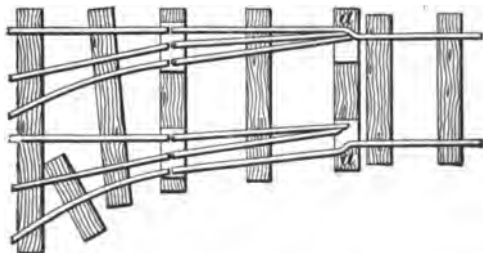

FIG. 530.

It can not be highly recommended, in any case, for inside switches. The short curves or "kinks" in the rails at the points *a, a* will derail the cars while passing outwards, if they are running at a high speed.

**1683.** Fig. 531 shows a rough and ready arrangement where a turnout or any other condition requires the temporary use of a switch. The ordinary form for narrow gauges consists of a movable rail *a*, about 6 feet long, pivoted

on a center *b*. Where the curve is not great, this arrange-

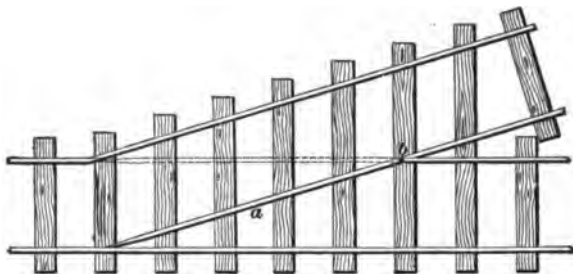

FIG. 531.

ment acts admirably. The dotted line shows the position of the rail *a* when the straight road is in use.

**1684.** Fig. 532 shows an excellent switch for permanent tracks in coal mines. No frog or latch is required. By

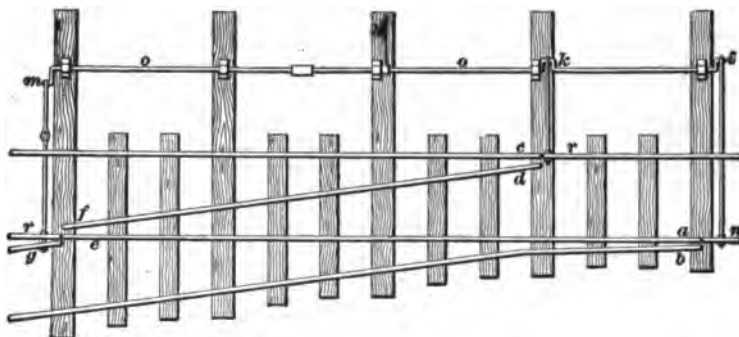

FIG. 532.

throwing over the lever *h*, the throw-rod *o* moves the throws *i k m*, so that the rails *r* will face the rail *d f*, the rail *n* will face the rail *b*, and the rail *g* will face the rail *f*.

The lead and other rails can be reduced to any required length to suit circumstances. When the lead rail *f d* is from 12 to 16 feet long, and the other lengths are in proportion, the switch gives excellent results. It should not be made of less than 20-pound rail, and heavier will suit better. By this device, it is seen that no frog is needed, and the joints are broken, i. e., they do not occur opposite each other, or on the same tie.

**1685.** Fig. 533 shows the ordinary stub switch, much used in coal mines. When the lever *l* is thrown over, the

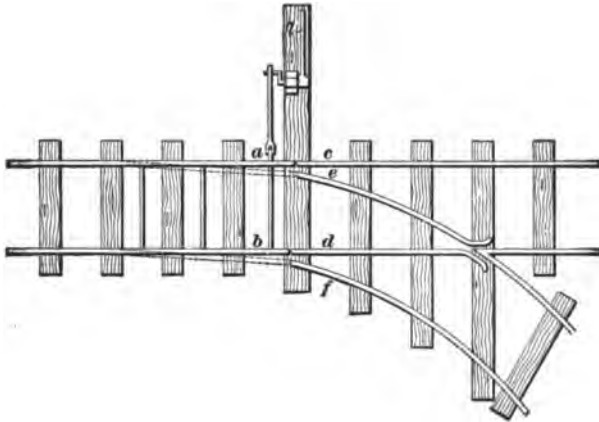

FIG. 533.

rails *a, b*, now facing *c, d*, are made to face rails *e, f*, as shown by dotted lines.

**1686.** When two tracks cross each other at any angle the same arrangement is used in mines as in railroads. They are called **grade crossings**. Fig. 534 shows a form which is self-explanatory. The cars must pass over this crossing slowly because the roads are broken.

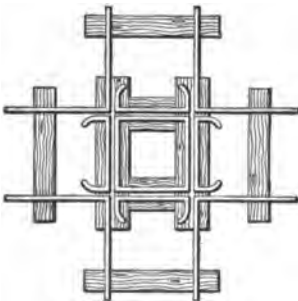

FIG. 534.

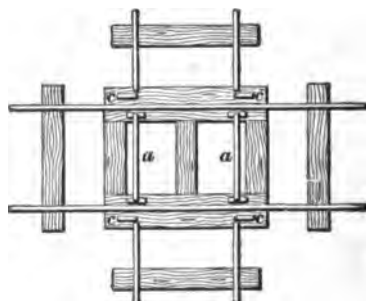

FIG. 535.

**1687.** When a subordinate road crosses a main road, along which the cars pass rapidly, the main road is left unbroken and the subordinate road is built the height of the

rail higher than the main road, and a crossing like that shown in Fig. 535 is used. The crosslatches *c* are sometimes held in place by blocks placed at the ends of the short rails inside the main track, as shown at the end of the rail *a*, Fig. 529. However, it is best to hold the latches in place by an iron plate having a shallow groove and placed at each end of the short rails *a*, *a*, so that, in case of neglect to take the latches off the main track, the cars going either way along the main track will remove them and prevent the trip from being derailed.

**1688.** Fig. 536 shows a convenient switch arrangement for the foot of inclined planes. A uniform grade is continued down to point *A*, and from that towards *B* the grade is just sufficient to cause the cars to clear the switch. In the loaded track *D* the grade is such that the full cars will gravitate from the point *D* to the point *A*. The movable rails *a*, *a* are bound together at each end by clamp-rods or spreaders, or bridles, and securely fastened in the center so

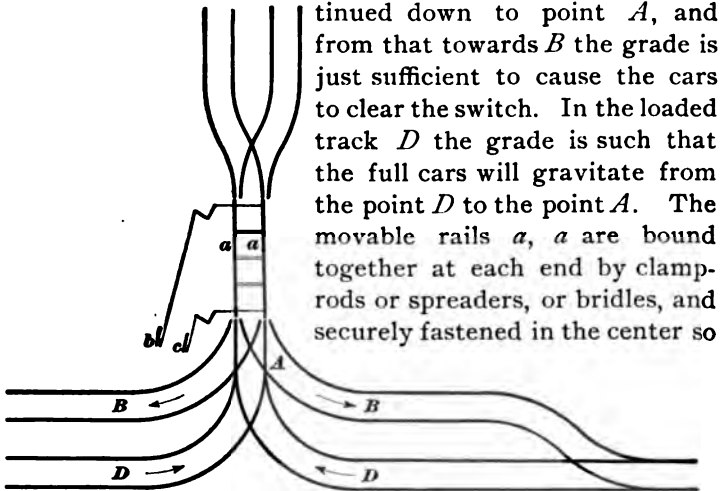

FIG. 536.

that they can not slip longitudinally. By using levers *b* and *c*, the rails *a*, *a* are adjusted to suit the road on which the trip is to travel. Care must be taken not to make the mistake of sending the trip upwards on the same track on which the down trip is descending.

**1689.** Fig. 537 shows a plan *A* and a profile *B* of a method of connecting the roads of a level, or gangway, to the road in the slope. At a distance of forty to fifty feet above the landing, or gangway *g*, the slope *s* is widened out



to accommodate the branch *b* leading into the landing loaded track *l*. This branch descends with a gradually lessening grade, until at the level of the gangway it turns into the main loaded track. A short distance above the gangway a bridge or door *d* is placed, which, when closed, forms a latch by which the empty cars are taken off the slope. The empty track *e* is about 6 feet higher than the loaded track *l*, and is carried over it on a trestle.

The figure shows in particular the plan as arranged for a single slope, or one side only of a slope taking coal from both sides. When coal is being raised from this landing, the bridge is closed; the empty cars come down and are run off over the bridge, the cars are unhooked from the rope, and the hook and chain are thrown down to the track below on which the loaded cars are standing; the loaded cars are attached and the cars are hauled to the main track on the slope. This plan can only be economically employed in

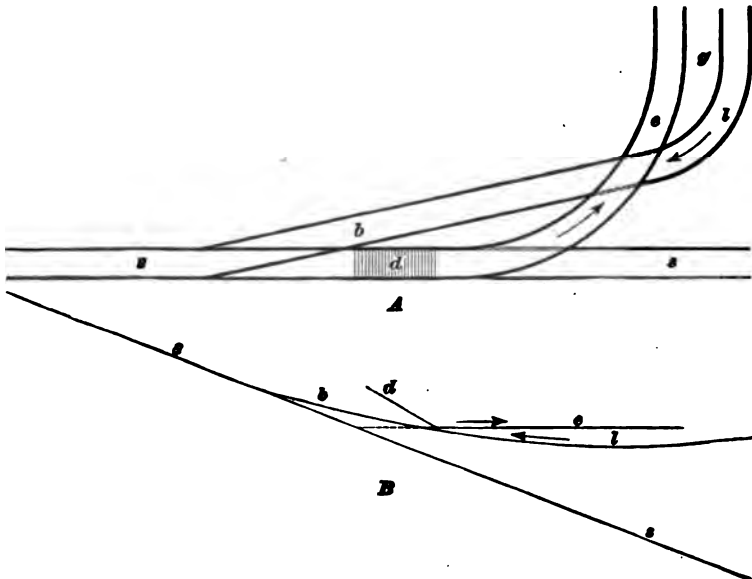

FIG. 537.

thick seams, as the height necessary to allow one track to cross the other on a trestle can not be obtained in seams of

moderate thickness without taking down a large amount of the top. By this method the cars can be handled on the landing by gravity.

**1690.** Fig. 538 shows an excellent method of laying switches in either thick or thin seams where the pitch does not exceed 20°.

When there is only one track in the slope and coal is hoisted from both sides, the same arrangement is used on each side; but to avoid complications, such as crossings, etc., it is best to have one landing or lift just the length of the switch on the main track further down the slope, as indicated by the dotted lines. The loaded track *l* and the empty track *e* join before they strike the track *s* in the slope.

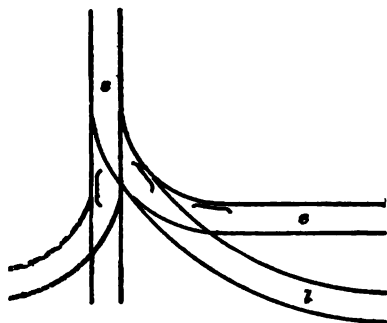

FIG. 538.

**1691.** Fig. 539 shows a plan *A* and profile *B* of a switch

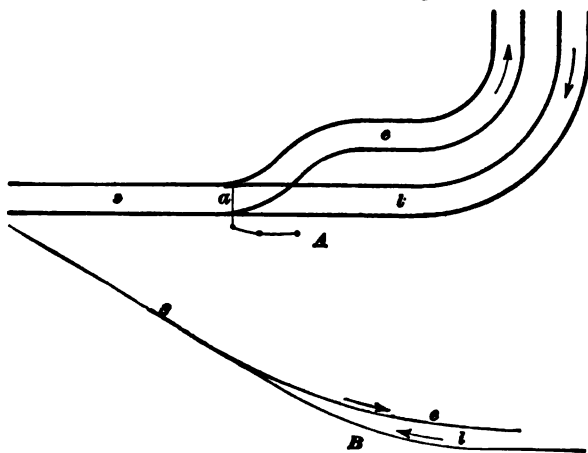

FIG. 539.

used at the bottom of a slope. The figure shows one side only of the slope, the other side being similar. At the

junction *a* of the two roads there is a pair of spring-latches, causing the empty cars as they descend the slope to take the road *e*. The empty cars pull the rope in to where it can be attached to the loaded cars which are standing near the slope on the road *l*.

**1692.** Fig. 540 shows a plan of the switches at the bottom of a slope in which double tracks are used. The two tracks in the slope *s* unite at the point *p* where there are

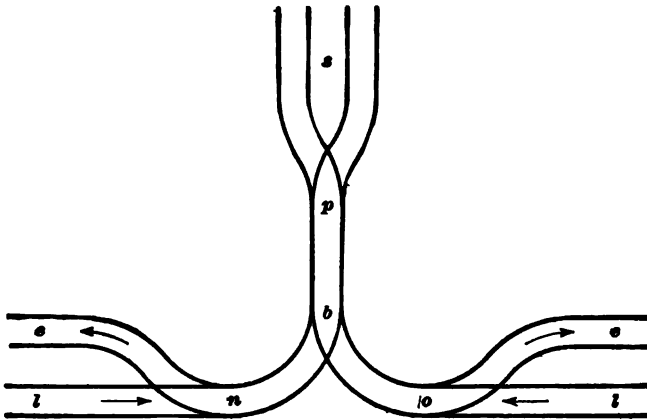

FIG. 540.

latches set by the cars; then at the point *b* two roads branch off, one to the right and the other to the left; and, finally, at the points *n* and *o*, empty tracks *e, e* branch off the loaded tracks *l, l*. The latches at the point *b* must be set by hand, while those at the points *n* and *o* may be spring-latches. The descending empty trip should have sufficient momentum when it reaches the bottom to run along the road *e* far enough to clear the track for the loaded cars standing on the track *l*.

**1693.** Fig. 541 shows a plan by which the switches at the bottom can be so arranged and graded that the cars can be handled by gravity. At the points *a, b* spring-latches may be placed; while at *p* the latches must be set by a lever, for the loaded cars coming from either of the loaded tracks *l, l* must be sent up the road *a* or *b*, depending upon which

the empty cars last descended. The latches at *j* are set by the cars which pass over them only one way. It will be observed by examining the figure that the empty cars must take the empty track *e* on that particular side on which they are descending. This requires that an equal number of

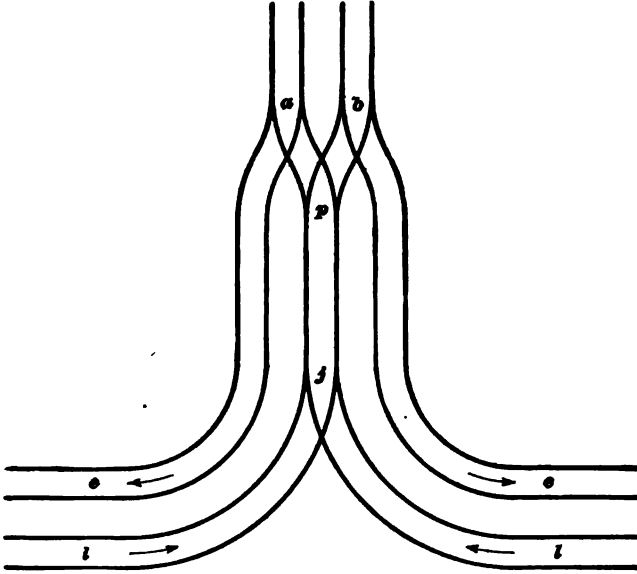

FIG. 641.

loaded cars are supplied by each side. Sometimes the loaded tracks *l, l* are connected by a straight track across the bottom of the slope, for the purpose of transferring cars from one side to the other in case one side does not furnish as much coal as the other. Although this plan requires width at the bottom of the slope for but three tracks, it necessitates an extra curve in the loaded tracks, which is an objectionable feature.

**1694.** The arrangement of the tracks on a slope should be such that there will be as few switches as possible on the slope itself; that the track will be unbroken; that there will be nothing standing at the bottom in line with the tracks in the slope; and that the cars can be handled at the bottom by gravity. The arrangement of the tracks

at the top of the slope is often similar to the bottom arrangement. It is always best, however, where there are two roads on the slope, to carry them over the knuckle instead of joining them, as is sometimes done, before they reach the knuckle and beyond which there are again two roads.

**1695.** When the pitch of the slope is so great that the coal falls out of the cars, a **gunboat** or a **slope-carriage** is used. The former is a special car into which the coal from the mine cars is dumped at the different landings along the slope and conveyed to the surface; and the latter is a car so constructed that, when it is placed on the slope, its top or floor will be horizontal. There is a track on the floor of the slope-carriage upon which the mine car is run. When the slope-carriage stops directly in front of a level, the empty car is taken off and a loaded one put on.

When more than one car is raised at a time, the slope-carriage has no track on it, but is covered with smooth plate iron. The landing is also laid with smooth plates. By this arrangement, with an empty and loaded track in the landing, 2, 3, 4, 5, or 6 cars are run on to the carriage without necessitating any movement up or down. The plate iron enables the cager to run the loaded car on at the upper end of the carriage and then slip it down to the end or against the next car, as the case may be.

**1696.** Fig. 542 shows the track arrangement of a shaft bottom where the cars are caged from both sides of the shaft. The loaded tracks *l, l* have a grade towards the shaft of from 1 to 3 per cent., depending upon the size of car and wheel used, while the empty tracks *e, e* are similarly graded in the opposite direction. When both sides of the shaft produce the same number of cars, the operation of caging is very much facilitated by the loaded car on the one side bumping the empty car off the cage on to the empty track on the other side; while, in the case of unequal production on the different sides of the shaft, the bottom man is frequently required to pull the empty car off the cage by hand to the side from which the loaded car is run on to the cage. In the

former case, if the roads and cars are in good condition, one

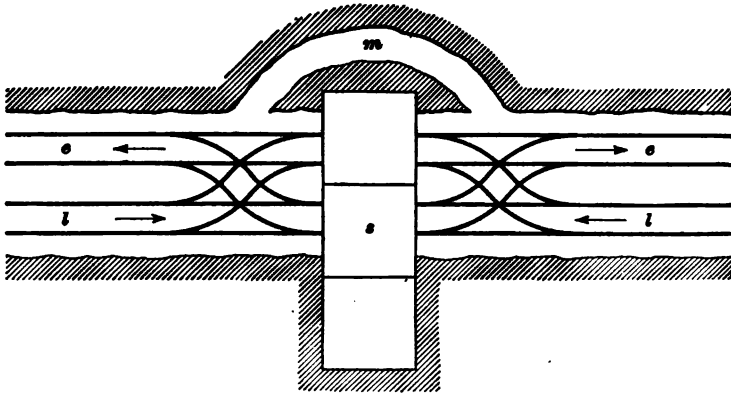

FIG. 542.

man on each side of the shaft can do the caging; but, in the latter case, both bottom men must be on the same side of

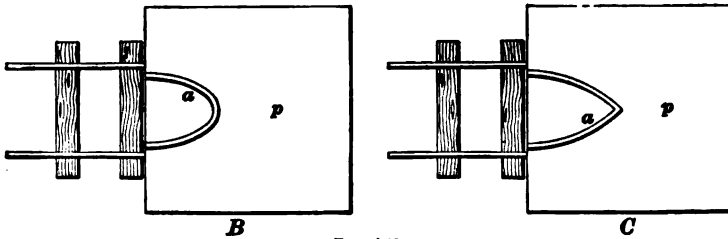
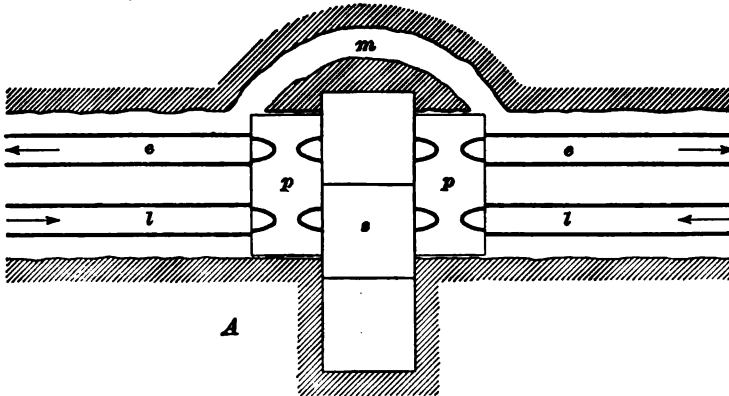

FIG. 543.

the shaft, and even then the two can not cage as easily or as

rapidly from the one side as the one could when both sides of the shaft were working equally. The manway *m* is used to pass from one side of the shaft to the other, as it is dangerous to pass through the shaft.

**1697.** Fig. 543 *A* shows the arrangement of the tracks at the shaft-bottom when plates *p*, *p* are used. The operation of caging is similar to that just described, except that the car is run on to the plate *p* and directed to the proper cage or track, as the case may be. The use of plates is limited to small cars holding not more than 1,600 pounds of coal. The grades on the loaded tracks *l*, *l* and on the empty tracks *e*, *e* are similar to the corresponding tracks in Fig. 542. The arrangement of the manway *m* around the shaft *s* is also like that in Fig. 542. *B* and *C* show two forms of tongues *a*, *a* placed upon the plates *p*, *p*, and their proper position in front of the tracks. The tongue *a* is raised about 1½ inches above the plate *p* and directs the flanges of the wheels so that the treads will take the rails as the car leaves the plate.

---

## D A M S .

---

### USE OF DAMS.

**1698.** Dams built in a mine are of somewhat different form from those erected on the surface, and, therefore, require special attention on the part of the mining student. They do not present, in general, very great difficulties. A full understanding of the conditions under which they are required, and the surroundings of their proposed location, is needed to determine their shape, the nature of the material of which they are to be constructed, and their size.

**1699.** The two principal requirements of a dam are: 1. That it shall be perfectly water-tight. 2. That it shall be capable of resisting the pressure that may be brought to bear upon it. That a dam may be water-tight, it must be constructed of impervious material, and the pressure must tend to close, rather than to open, the joints in the structure;

these joints must, moreover, be well calked to prevent the passage of water. It is also especially necessary to make the junction between the dam and the sides, roof, and floor of the passage in such a manner that the water can not force its way through it. To render the dam capable of resisting the pressure that may subsequently be brought to bear upon it, it must be constructed of strong materials, and these must be so disposed as to offer sufficient resistance without becoming deformed. It must be borne in mind in designing and erecting dams that the pressure to be resisted is usually very great, necessitating the best of materials and workmanship.

**1700.** Dams are used in mines principally for the four following purposes:

1. To keep back surface water.
2. To keep back the water from old workings or from an adjoining mine.
3. To flood a portion of a mine in case of a mine fire.
4. To keep back the deleterious gases given off by old workings.

---

#### LOCATION OF DAMS.

**1701.** A dam should be located in such a place as will secure all the following important advantages, or as many of them as possible:

1. The site chosen should be under a good strong roof and should have a solid rock bottom.
2. The pillars against which the dam abuts should be solid, and of such size as will provide sufficient lateral strength.
3. The dam should be located in a place where the strata will not be disturbed by subsequent mining.
4. It should be located at a place where the opening in the seam is as narrow as possible.
5. It should be located at an accessible place.



## CONSTRUCTION OF DAMS.

**1702.** The construction of dams depends upon the amount of pressure they are to withstand, their probable life, the size of the dam, the time available for their construction, and the relative cost of the different materials.

The materials used in constructing dams in mines are wood, brick, or masonry, and their faces may be either straight wall or arched, depending upon the material used and the head of water.

**1703.** To understand the construction of dams to resist the pressure of water, it is necessary for the student to understand the following elementary principle of hydrostatics:

*At any given depth the pressure of water is equal in every direction, and is in direct proportion to its vertical depth.*

Thus, if a mine is flooded, and the *vertical* depth of the water is 100 feet, the pressure per square foot at the bottom is equal to the weight of 1 cubic foot of water multiplied by the depth in feet, or 100. Hence,  $62.5 \times 100 = 6,250$  pounds per square foot. At a point half-way down, the water will press against the sides with a pressure equal to  $\frac{1}{2} \times 62.5$  pounds = 3,125 pounds per square foot.

**1704.** Dams to divert the course of water, or to keep

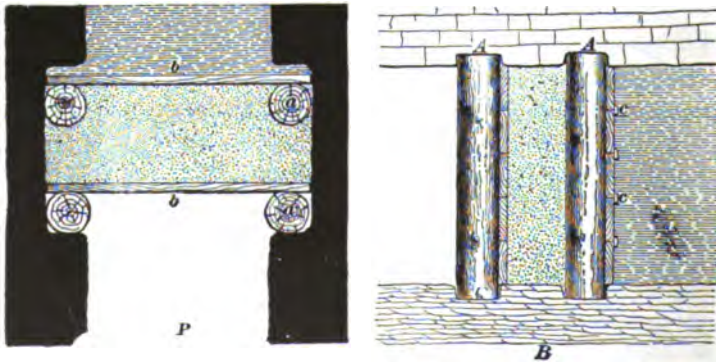

FIG. 544.

back gases, are subjected to very small pressures. In many

cases an ordinary stopping, such as is used to block an air-course, will suffice. This may be constructed of either wood, brick, or stone, the joints being made water-tight.

Dams to resist moderate pressures may be constructed of two walls of plank supported by props firmly fixed in the top and bottom, and with the space between filled with puddled clay. The joints of the planks should be battened on the side next the water. Fig. 544 shows a plan *P* and section *B* of such a dam, in which *a, a* are the posts, *b* planking, and *c, c* battens; puddled clay, which is from 1 to 2 feet thick, is also shown.

**1705.** Fig. 545 shows a wedge-shaped dam which is one of the best, and one which, under modifications according to circumstances, may be applied in most cases where any other dam can be effectively placed. This dam consists of pieces of wood, carefully dressed with a taper, and placed with the thick end next the water. The taper of each piece of timber depends upon the radius of the curvature of the dam, and is greater for dams of small radii. Each piece of timber should be tapered at the surface and properly numbered, so that when the separate pieces are taken into the mine they can readily be placed in their respective positions. Thoroughly dried timber should be used. The face of the dam is arched from side to side. The lengths of the pieces of wood depend upon the pressure which the dam will be required to resist, and also upon the area of the dam itself. They may vary from 3 to 8 feet in length and the *radius of the inner circle* of a wooden dam may be from 18 to 30 feet. Notwithstanding the most careful wedging, the pressure on the face of the dam is sometimes great enough to force the whole structure back. Therefore, it is advisable to so cut the sides of the passage that the forcing back of the dam will tend to wedge it still tighter.

**1706.** While the dam is being constructed, it is necessary to insert three iron pipes in it: one *a*, about a foot from the bottom, of sufficient size to carry off the feeder of water, or, if the feeder is very large, two pipes may be inserted; another *b*, about 18 inches in diameter, two feet

from the bottom, for the purpose of allowing the ingress and egress of the workmen during the insertion and wedging of the dam, and a third *c*, which should be from 3 to 6 inches in diameter, and placed near the top. A good, tight valve should

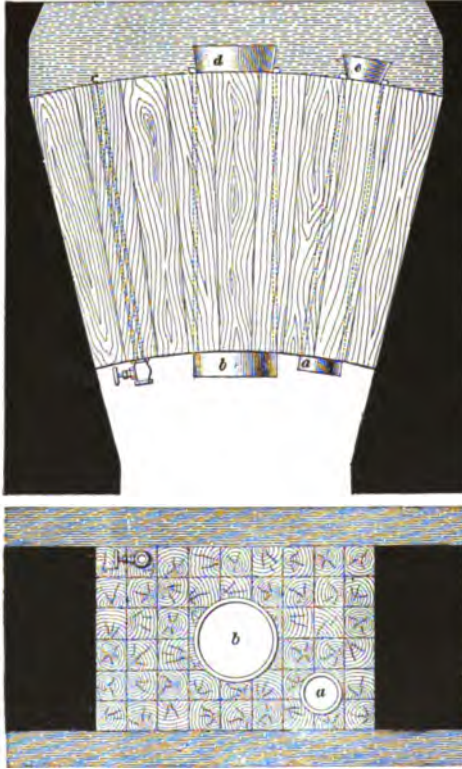

FIG. 545.

be placed on its outer end. This pipe can be used as an air vent while the water is rising. If at any time it is desired to draw the water off slowly, the valve can be opened.

The sides, top, and bottom of the seat of the dam should be lined with tarred flannel, so as to ensure a water-tight joint on all sides. After the tapered timbers have been placed in proper position, the wedging is commenced on the inside with wedges 12 inches long and  $3' \times 1'$  at their heads. After these

have been driven in at all the joints, and around the pipes, other wedges are driven in, of diminished size, as long as they can be entered, after which a chisel is used to prepare places for their insertion. The wedges must be perfectly dry. After the wedging is finished, the workmen drive the plug into the pipe *a* through which the water has been flowing. They then pass out through the pipe *b*, drawing after them the plug to close it, which has been placed

conveniently for so doing, and the work is completed. A dam of this description, 6' x 6' and from 6 to 8 feet thick, will resist a pressure of water of from 130 to 260 pounds per square inch. When the pressure is less, the dam may be made proportionately of less thickness, although under any circumstances rendering a wedge-shaped dam necessary, it would not be advisable to put in one less than 3 feet in thickness.

**1707.** Fig. 546 shows a sectional plan of a spherical dam built of brick and suitable for places where the coal, top, and bottom are hard. This dam is constructed of three concentric spherical arches dovetailed into the surrounding strata in such a manner that the elevation in a vertical section would have the same appearance as the plan which is shown, except that rock would be shown where the coal is shown on the plan. The object of forming a dovetail abutment is for the purpose of securing good support for the several arches of which the dam is composed, while at the same time cutting away as little of the surrounding strata as possible. The dam is 15 feet thick from *a* to *b* and has a maximum radius of about 30 feet. The arcs *g h*, *e f*, *c d* mark the spherical surfaces of the different arches which go furthest into the surrounding strata.

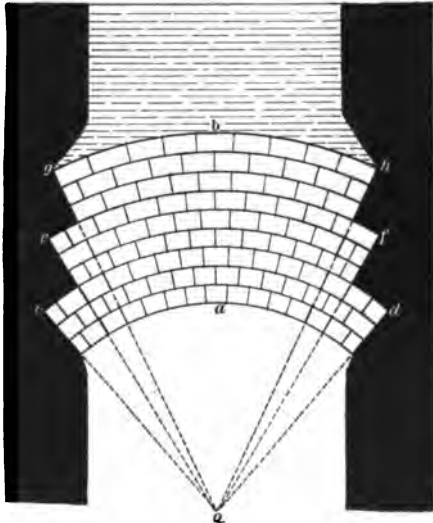

FIG. 546.

The radius of curvature of the arches of brick or masonry dams will depend upon the amount of pressure to be resisted and the size of the opening to be closed. For heavy

pressures, the rule is to make the radius  $o a$  equal to the height of the opening when trimmed up.

**1708.** Fig. 547 shows a plan of a brick dam built of two spherical arches  $D, D$  from 6 to 12 feet apart, the inter-

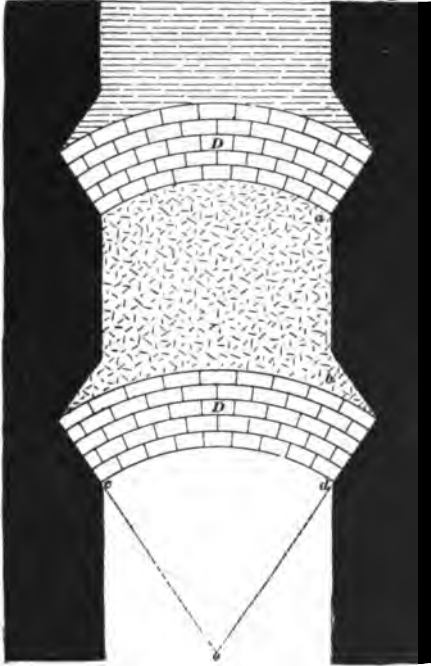
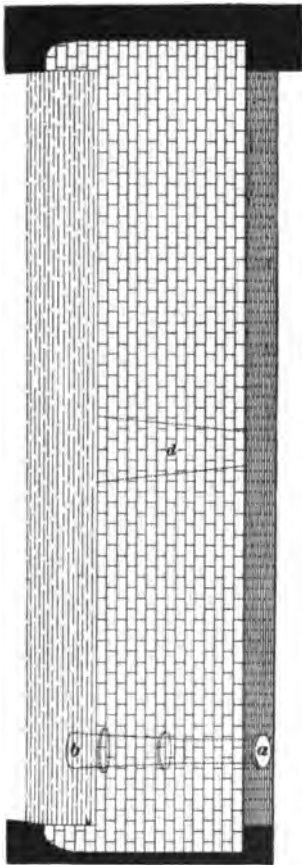

FIG. 547.

space being filled with puddled clay  $a b$ . This form of dam is suitable for bituminous mines, where the coal is soft. As in Fig. 546, a vertical section of this dam would also appear similar to the plan shown, except that the strata of the top and bottom would be shown where coal is shown on the plan. In this form of dam, the outer radius  $o c$  or  $o d$  should be equal to a similar radius  $o a$  of Fig. 546, and the thickness of each of the arches  $D, D$  should be at least one-half the thickness obtained by the formula which will

be given later. Pipes should be inserted in brick or stone dams for the same reason that they are put in wooden dams. The puddled clay is inserted to prevent leakage, and to transmit the pressure from one wall to the other.

**1709.** Fig. 548 shows a plan  $A$  and section  $B$  of a cylindrical brick dam built at a colliery in the anthracite region of Pennsylvania, to shut off a large inflow of water through the strata in the roof close to the face of the chamber. There is considerable depth of wash, or drift, over the seam, and it was thought advisable to abandon, for a time, all mining at that level until the coal below was worked out.



A

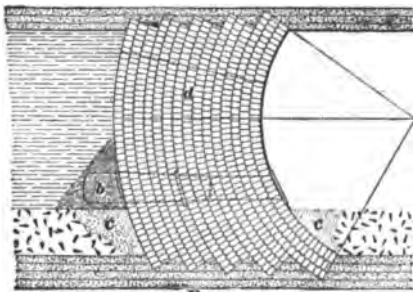

B

FIG. 548.

Therefore, the dam shown in Fig. 548 was built close to the break in the roof, so that no large quantity of water would be standing behind the dam. It was built of brick, 5 feet thick, laid in cement. Its length from pillar to pillar is 25 feet, arching from bottom to top. The pressure is nearly 100 pounds per square inch.

In Fig. 548, *a* shows the cast-iron pipe for the escape of water while the dam is being constructed; *b*, the tapered white pine plug turned to fit the pipe, and *d*, the manhole used by the workmen after having finished the dam from the inside and as an escape after driving the plug *b*. By reference to the figure, it will be seen that the soft stratum immediately under the coal was cut away and the brickwork dovetailed into the harder stratum, as it is into the top. Concrete *c* is placed at the front and back of the dam where the soft bottom has been taken up.

The proportions of the constituents of the mortar were : 1 barrel of cement, 2 barrels of sand, and  $\frac{1}{2}$  barrel of water. The joints were  $\frac{1}{2}$  inch wide. The mortar used for brick or stone dams should be the best Portland cement, except where the dam is constructed to resist a comparatively small pressure.

It should be observed by the student that this dam is formed of separate cylindrical arches, each of which is dovetailed into the top and bottom; and built straight across the passageway, because it would be an expensive matter to arch such a wide dam longitudinally. In fact, it would not be necessary, unless extraordinary pressure must be resisted.

**1710.** The thickness of cylindrical or spherical dams to resist a given pressure may be approximately determined by the following formulas, by Prof. W. Steadman Aldis, which allow a safety factor of 10 :

$T$  = thickness in inches :

$R$  = short radius in inches;

$U$  = ultimate crushing strength in pounds per square inch, which is, for timber, 8,000; for stone, 6,000; and for brick, 2,500;

$P$  = head of water in pounds per square inch.

Then, for a cylindrical dam,

$$T = R \left\{ 1 - \sqrt{1 - \frac{20P}{U}} \right\}. \quad (88.)$$

For a spherical dam,

$$T = R \left\{ 1 - \sqrt{1 - \frac{15P}{U}} \right\}. \quad (89.)$$

These formulas give very small thicknesses for dams to resist comparatively slight pressures. In no case, when a water head of over 10 feet is to be resisted, is it good practice to make the dam less than 3 feet thick. For heavy pressures the formulas are safe, provided their results exceed 36 inches, after being multiplied by 2.

**EXAMPLE.**—What should be the thickness of a cylindrical dam built of timber, having an external radius of 20 feet, under a head of 100 feet of water?

**SOLUTION.**— $P = 100' \times .484$ , pressure per square inch for each foot of height = 48.4 lb.

Substituting values for letters, we have

$$T = 20 \times 12 \left( 1 - \sqrt[3]{1 - \frac{20 \times 48.4}{8,000}} \right) = 13.39 \text{ in.}$$

$20 \times 48.4 = 868$ ;  $\frac{868}{8,000} = 0.1085$ ;  $1 - 0.1085 = 0.8915$ ;  $\sqrt[3]{.8915} = .9442$ ;  $1 - .9442 = .0558$ , and  $240 \times .0558 = 13.39$  in. Ans.

This result is theoretically correct, but as a thickness of 13.39 inches will give a comparatively small bearing surface for one wedge on another, the rule of making a wooden dam at least 3 feet thick should be applied here.

**EXAMPLE.**—What should be the thickness of a spherical dam built of brick, having an external radius of 20 feet, under a head of 100 feet of water?

**SOLUTION.**—Substituting the figures for the letters of the formula for spherical dams, we have

$$T = 20 \times 12 \left( 1 - \sqrt[3]{1 - \frac{15 \times 48.4}{2,500}} \right) = 22.968 \text{ in.}$$

$\frac{48.4 \times 15}{2,500} = 0.2604$ ;  $1 - 0.2604 = .7396$ ;  $\sqrt[3]{.7396} = .9043$ ;  $1 - .9043 = .0957$ , and  $.0957 \times 240 = 22.968$  in., say 23 in. Ans.

To prevent leakage in dams, the thickness, notwithstanding the safety factor of 10, should be doubled.



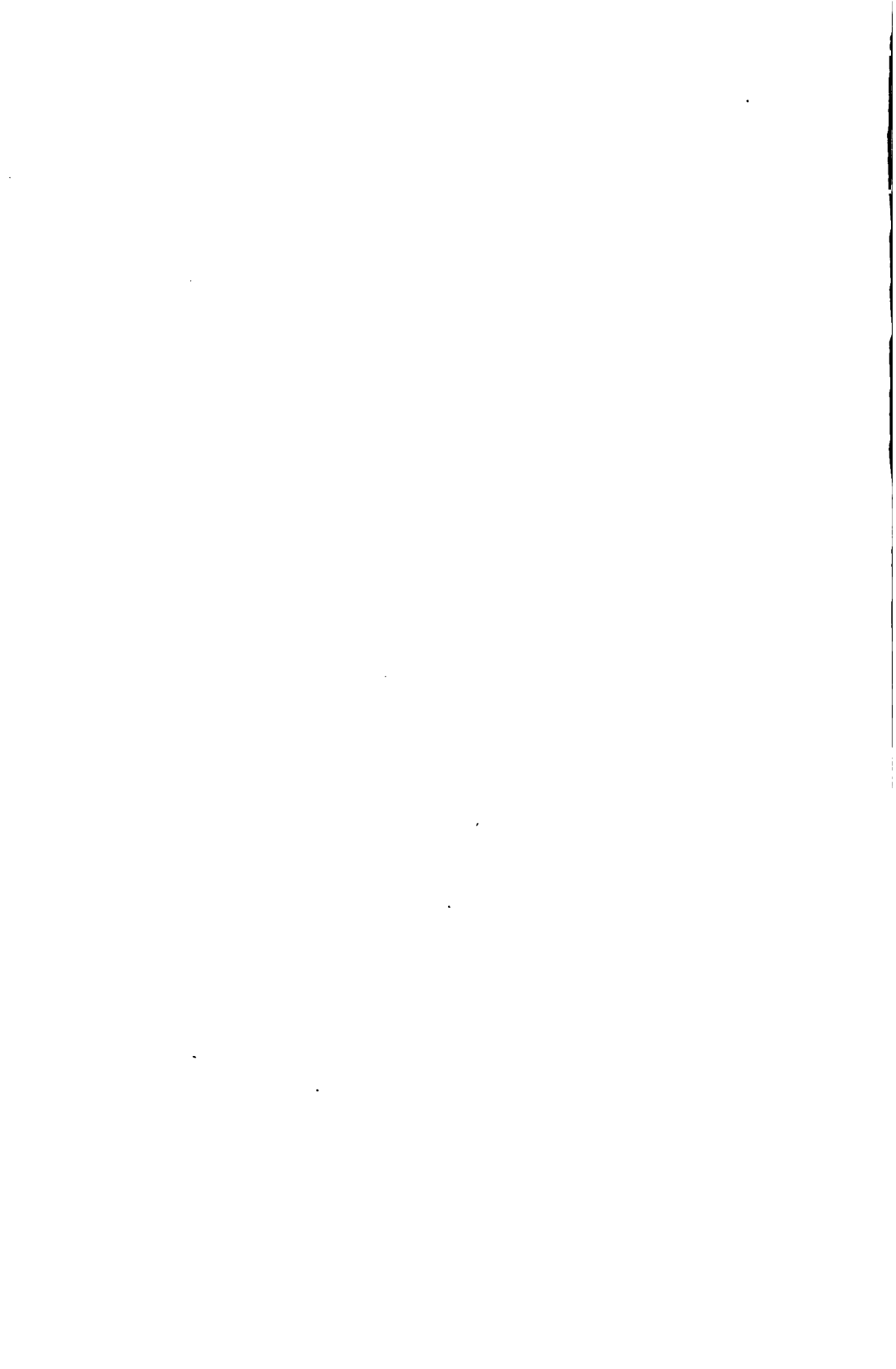

# METHODS OF WORKING COAL MINES.

(PART 2.)

---

## LONGWALL METHODS.

---

### INTRODUCTION.

**1711.** When coal is found at a depth beyond 1,500 feet, it is unprofitable, if not impossible, to work it by the pillar and chamber or pillar and stall method, because the enormous weight will either crush the pillars or force them into the strata immediately above and below the seam, resulting in closing up the haulways entirely. In such cases a method known as **longwall** is used; this method, strictly speaking, means taking out all the coal in one operation, commencing usually near the opening and carrying the excavation towards the property limits. The passageways are maintained by walls built of rough material obtained from the floor or roof of the mine, or it may be taken into the mine from the surface.

A narrow space along the entire working face is kept open and advanced as the face advances, by supporting the superincumbent strata by filling in the space from which the coal has been removed with the refuse of the seam or material blasted from the top or bottom of the haulways. **Wooden nogs** and **chocks** are used to support the roof where waste material can not conveniently be obtained in sufficient quantities, or where it does not make good building material for the road sides. The nogs are built of logs piled two on two, to form a square pillar, and the chocks are similarly built, except that small pieces of hard wood 6" × 6" × 18" are used instead of logs.

§ 15

For notice of the copyright, see page immediately following the title page.

**1712.** The width of the space between the gob and coal face depends upon the nature of the top. In thin seams where the top is soft and brittle it may not be more than 3 feet, while in a seam 10 feet thick and having a good top it may be 8 or 10 feet wide, or more. The nature of the top in this way decides the number of roads necessary to mine the coal. If there is a good top, but few roads are required, as the car is taken along the face, which is approached by roads from 200 to 1,000 feet apart. But if the top is brittle, the space is necessarily too narrow for the car to be taken along the face, and, indeed, often too narrow for the men to work in conveniently. In such cases it is laborious to shovel the coal to the road-heads, which operation is productive of a good deal of slack. Therefore, roads under brittle top are seldom more than 16 yards apart, and frequently not more than 12 yards apart. A sled, sometimes called a buggy (a small box on sledge runners), is used to convey the coal to the road-head, so that the roads may be less numerous, but this method has a very limited practice in America.

**1713.** The longwall method of working, besides being the only recourse for the mining of seams found at great depths, is used also for thin seams at moderate depths for the purpose of securing exhaustive mining and a better marketable condition of the coal. The system is especially applicable to thin seams when they have a **following stone**, or stratum overlying the seam, and which falls as the coal is removed.

---

#### SHAFT PILLARS.

**1714.** In some coal fields no shaft pillars are left when longwall is employed in seams of moderate thickness. In such a case the coal is all mined out, and the gob carefully filled in with the refuse of the seam, material taken from the roof, or with stowing material taken into the mine. This work of stowing must be very carefully done, ramming being in some cases resorted to. In this way it is claimed that subsidence gradually takes place, until the gob is reduced to almost the compactness of the original strata, without

destroying the line of shaft. When this condition is reached, there is no danger at any future time of the shaft being destroyed by a creep. If a depth is reached at which narrow passages through the pillar can not be kept open, it is evident that a shaft pillar at such a depth is out of the question, regardless of the thickness of the seam.

There are places on record in North America where the slope openings can not be maintained at a depth of 600 feet in the solid coal, while there is but little trouble in maintaining them when the coal is all taken out, starting at a point above which the weight of the strata does not affect the pillar. Nevertheless, most longwall workings are now opened by leaving a shaft pillar of a suitable size, which will resist the weight of the superincumbent strata until the second break takes place over the excavation as it advances from the shaft. This will relieve the pillar of all weight except that due to the strata to be maintained intact for the preservation of the shaft. What was said in Part 1, Art. 1576, regarding the size of shaft pillars is true here also.

#### THE WORKING FACE.

**1715. Form of Working Face.**—In longwall workings it is the aim to carry the face in the form of a straight line, a circle, an ellipse, or an arc of either of the two latter, depending upon the relative prominence of the cleats of the coal, the nature of the top and bottom, and the dip. The circumstances determining which of these forms will be suitable for any particular case will be made evident later.

**1716. Fast Sides.**—A weak top has a tendency to break along the line formed by the working faces, and if the line of faces is long this tendency to break in the roof becomes dangerous. To obviate this, the line is broken into steps and the places kept in advance of each succeeding one. The length between the steps may be regulated to any required distance, from 12 yards upwards. The great objections to fast sides are that the pressure destroys the coal on the corners, their cutting incurs an extra cost in the production, and the many crooks obstruct ventilation.

**1717. Direction of Working Face.**—The faces may advance :

1. Perpendicularly to the cleavage planes or **cleats**, or “on the face.”
2. Parallel to the cleats, or “on the ends.”
3. Obliquely, or at an angle of  $45^\circ$  with the cleats, or “half on.”
4. Obliquely between the angles of  $1^\circ$  and  $45^\circ$  from the cleats, or “short horn.”
5. Obliquely between the angles of  $45^\circ$  and  $90^\circ$  from the cleats, or “long horn.”

It must not be supposed that it is a matter of indifference which of these directions should be adopted in any given case. It depends on the breaking down of the coal, the physical condition of the coal after it has been broken down, and, in some cases, where the cleat of the roof runs parallel with the cleat of the coal, the safety of the workmen. Therefore, it is very important that the circumstances of the case be considered when laying out the workings of a colliery.

**1718.** The object of all methods and expedients adopted in mining are to obtain the greatest quantity of coal, in the best condition, at the least cost. Since the direction of the face affects the physical condition of the coal, the labor of breaking it down, and the safety of the miner, it is obvious that it bears directly on the cost of production. Two of the principal aims are to reduce the amount of slack to a minimum and to reduce the amount of labor. These are frequently antagonistic, and when this is the case a middle course must be taken.

**1719.** By working a seam directly on the face the coal may be mined at a minimum price, while the waste or slack may be at the maximum by the weight breaking the coal off when the “backs” (cleats) are close together.

Slack (except in the best coking coals) is comparatively worthless; therefore, the profit must be made entirely from

the nut and lump coal. It is, therefore, apparent that it is better to mine the coal in a direction that will increase the ratio of lump, even if the cost of labor be increased.

**1720.** Coal divides readily along the planes of cleavage, known as cleats, and when some of these cleavage planes are but slightly developed, the coal offers great resistance, comparatively speaking, in a direction perpendicular to the cleat. As longwall workings advance, the roof bends along the line of wall faces and finally breaks, falling into the gob. Two forces are brought into action by this bending: the one which acts downwards tending to crush the coal, and to cause it to cleave parallel to the wall face on the side next the gob, which is unsupported; and the one which acts in a

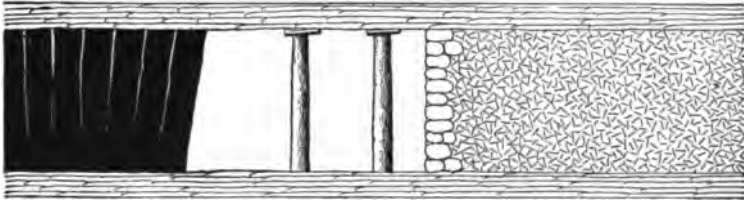

FIG. 549.

horizontal direction, being applied only at the upper surface of the seam, tends to divide the seam parallel to the face, in exceedingly thin scales. Suppose that the seam divides vertically, and in a direction parallel to the face, into slabs of a definite thickness. The horizontal force applied to the upper edge of each of these slabs tends to rotate it upon its lower edge as a center, by which motion the upper edge will be advanced towards the unsupported side, and the wall face will be inclined as shown in Fig. 549. But, as the force acts more intensely as the wall face is approached, the slabs from the face inwards will be less and less inclined, i. e., they will have been separated by a less distance towards the upper edges. Coal is never perfectly homogeneous, and the cleaving force is never applied with the same intensity at every point. Therefore, the seam has a tendency to break up, under the action of the descending roof, into slabs of

irregular thickness, or it may be into prisms of irregular dimensions, in consequence of an unequal resistance. The effects are shown in Fig. 550.

It will be seen in Fig. 550 that the pressure of the descend-

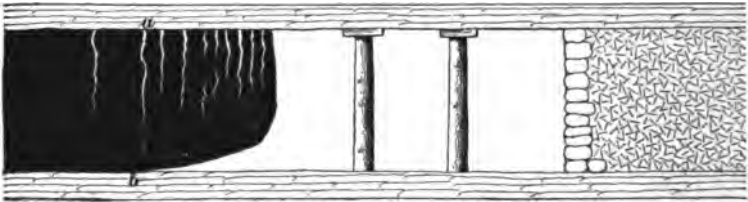

FIG. 550.

ing roof has split up the seam to a distance of about 4 feet from the face, and that the cracks so caused increase in number and in width towards the face.

**1721.** It seems evident that the degree to which the coal will be broken under such conditions as these will depend upon:

1. The strength of the roof, which may bend and drop slowly, or break off short.
2. The nature of the roof, which may consist of hard or soft rock.
3. The pitch of the roof, which largely determines the pressure at the wall face.
4. The direction of the workings, whether to the rise or to the dip.
5. The strength of the coal.
6. The direction of the cleats relative to the wall face.

**1722.** Now, consider the last circumstance, which involves the whole of the foregoing. Suppose the face in Fig. 550 is parallel to the cleats, i. e., that the faces are advancing across the cleats. The direction in which the pressure tends to cleave the coal coincides with the face cleats, and it is, therefore, clear that the cleaving force will act under the most favorable conditions. If the coal be strong, a few extensive lines of fracture may be caused

which will greatly facilitate the getting of the coal by breaking it up into large blocks or slabs, thereby saving much labor in bringing it down. The mass can be subsequently broken up into blocks capable of being handled.

**1723.** When the face is undercut, as shown in Fig. 550, the pressure of the roof plus the weight of unsupported coal tends to produce a fracture along the line  $a b$ , and if  $a b$  be a plane of cleavage, the conditions will be most favorable to the action of the pressure. The foregoing shows that advancing the faces across the principal cleats reduces labor to a minimum, thereby satisfying the conditions of least cost.

But the physical condition of the coal is a consideration of equal importance; for, if the cheaper labor is secured at the cost of an increased amount of slack, the result may really be a loss instead of a gain, when the production is put upon the market.

**1724.** If the coal be of a weak and tender character, there will be numerous short lines traversing the mass vertically and horizontally, and dividing it into thin slabs and small prisms, instead of the long slabs and few lines of fracture as in the former case. When the "web," or mass, falls, these slabs and prisms are very easily broken across, and the same liability to easy fracture exists during the operation of breaking up the web, or mass, and loading it into cars. A considerable part of the coal is ground small by the roof pressure, especially along the top of the face, where the greatest pressure exists. The final result is a very large amount of slack for longwall mining.

The ease with which the coal falls is a source of danger, which must be provided against by employing sprags to support the "web" while the coal is being undercut. It is evident, under these conditions, that the advantages gained by working "face on" are nullified by the increased percentage of slack.

**1725.** If the faces are advancing on the end of the coal, or "end on," the pressure of the roof tends to cleave the coal perpendicularly to the cleat or principal cleavage plane,



and the resulting condition is most unfavorable to the action of the cleaving forces. The "end on" plan is the best possible condition to resist the cleaving and crushing action of the pressure due to the descent of the roof. Therefore, the coal will be obtained in larger blocks, and the waste or slack will be reduced to a minimum. As an offset against this improvement in the physical condition of the coal, the labor will cost more. The likelihood is that the better price for the whole production will be greater than the extra price paid for mining.

**1726.** "Half on" is a method midway between those just discussed, and "long horn" and "short horn" are simply variations between "face on" and "half on," and "half on" and "end on." Any one of these methods may be made necessary by the dip of the seam, the texture of the coal, etc. "End on," for instance, may be advantageous in a moderately strong seam where the pressure is great.

**1727.** The dip is another important consideration in this same connection, which, irrespective of the other conditions, may determine the direction in which the faces shall be driven. The manner in which the dip most frequently determines the direction is by affecting the mode of conveying the coal to the shaft. It is plain to all that it is of the highest importance to take advantage of the force of gravity. By arranging the face of workings and line of haulage roads in such a manner that the coal, from the moment it breaks from the seam, will gravitate continually to the shaft bottom, an immense amount of labor will be saved. Even when an inside slope is driven from the shaft bottom, to work the coal to the dip, the levels and temporary roads are laid out to take advantage of the force of gravity.

**1728.** The inclined plane delivers coal at the smallest cost when it is practicable. A slant road is sometimes used instead of an incline on the full pitch, so that mule haulage can be used. Conditions seldom justify the use of a slant

where an incline could be used, because a slant is longer than an incline to reach the same coal, and in pitching seams the *buildings*, or packs, are harder to keep in repair.

The directions of dip and cleat have no fixed relation to each other; sometimes they are parallel, in other seams they are at right angles to each other, and in different districts they may vary from each other through all the points of the compass.

**1729.** There are many difficulties in the application of longwall to seams exceeding a dip of  $12^\circ$ , but the chief ones are found to be:

1. The tendency of the roof to slip and sink back away from the face, thus taking the desired pressure from the coal. In longwall working one of the great objects aimed at is so to control and regulate the pressure of the roof strata as to keep a *continuous* or *traveling* weight upon the

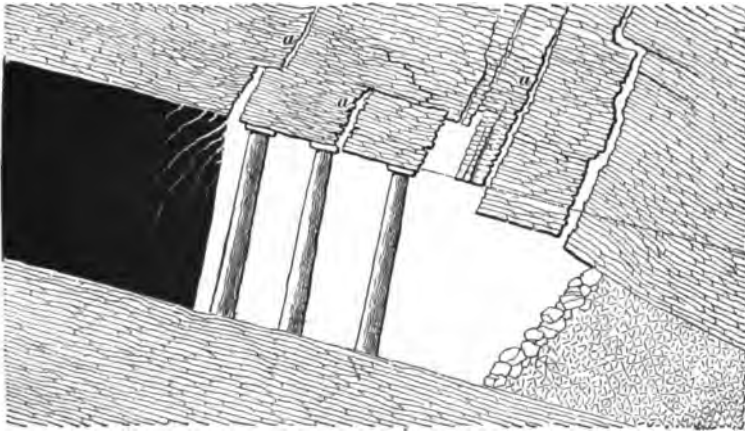

FIG. 551.

coal, thus reducing the labor of mining, and breaking down the coal without the necessity of much, if any, blasting, care being taken not to crush the coal. In flatter seams this is a comparatively easy matter, as with moderate care it is not difficult to control the pressure of the roof with packs and timbering. But, as the inclination increases, there

is considerable difficulty in preventing the broken masses of the roof gravitating away from the coal in the direction of the dip of the measures, and either sinking in front of the face line or bringing excessive pressure to bear on the edges of the coal face, thus crushing the coal. A good example of this is given in Fig. 551, which shows an actual condition that existed in the Staffordshire (England) district where the coal was badly crushed. The breaks  $\alpha$  average from  $50^\circ$  to  $60^\circ$  from the horizontal. The roof has slipped down hill, owing to careless packing, and throws excessive pressure on the edge of the coal, which becomes seriously crushed.

Fig. 552 shows the coal strong and firm and broken off at the back of the mining. In this case the roof has broken

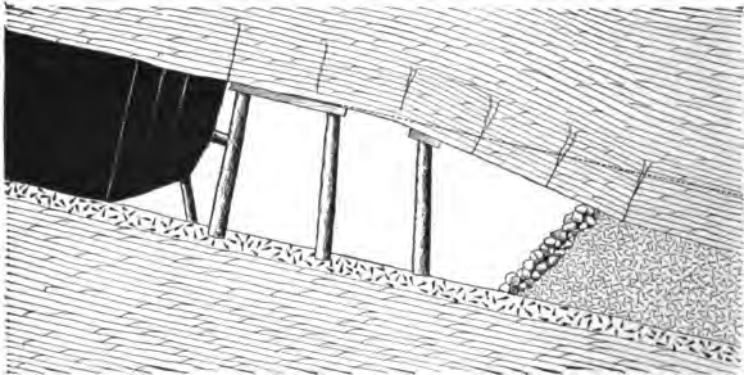

FIG. 552.

off properly, relieving the coal face of any unnecessary weight, for while the roof is broken above the face of the coal, that portion of it which is supported by the props still keeps the roof above the mining from sliding forwards and crushing the coal, as is done in the former case.

2. The disturbance of the packs, etc., on the high side of the levels or gangways, caused by the slipping of the roof. This is shown in Fig. 553, in which the pack  $w$ , originally 4 feet high, has been pressed down to 3 feet on the side of the level or gangway, while on the rise side of the same pack, at the point  $r$ , it is only 18 inches thick, showing a settling

of 12 inches in the first and 30 inches in the second instance. This is partly due to the extra strength of the support, due

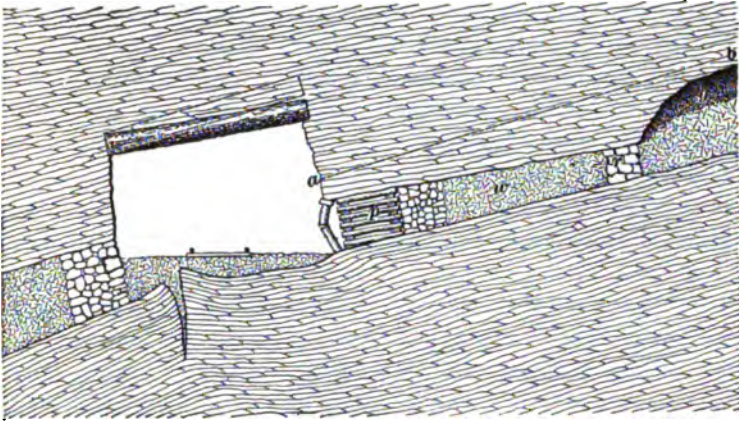

FIG. 558.

to the wooden chock *p* on the roadside, and also to some extent to the area of unsupported roof in the waste or gob *g* above, between the rise side of the pack and the first break of the face line. The dotted line *a b* shows the original position of the roof.

The immediate effect of this unequal sinking is to reduce the original inclination of the roof in and immediately above the level road, and it naturally follows that the tendency to slip will be greatly reduced. It has been found that in roads where the original inclination of the roof was  $16^{\circ}$  or  $17^{\circ}$ , the angle with the horizontal is reduced to  $10^{\circ}$  in a very short time after the coal has been worked out.

**1730.** *Systematic mining and regular progressive advance of the working faces* are essential points in working by the longwall systems.

Since the line of "break" is about at right angles to the seam, the line of greatest pressure is clearly fixed if the work is properly and systematically carried out. In connection with the line of "break," in pitching seams, the "pull" due to gravitation down hill must also be considered.

It will be seen that, in order to throw the pressure forward, in advance of the face line, it is necessary to support the roof in the same manner that the face of the coal is spragged while it is being mined, but this can only be done to a limited extent. If an attempt be made to support too great an area of roof, the timbers will be broken and the prime object frustrated. Therefore, timbering should be kept within the smallest possible limit, so that, without using an excessive quantity of timber, the roof under which the miner works is kept well supported, and the roof a short distance back is allowed to fall and thus relieve the timbers from excessive pressure.

**1731.** At the working faces the props should be carefully set in line so as to assist in breaking the roof parallel to the general face line. The best results are obtained by setting the rows of props in exact line at right angles to the face line, so that each prop in the *several rows used* will be in the best position to help the next, which would not be the case if the props were **staggered** or set without order. This system of staggering the props is in use in many longwall mines, but it is hard to show the advantage derived from it. The row of props close to the face is of great importance in preventing the roof from cutting, or sinking in front of the coal. The breadth of roof supported by props varies from 3 to 8 or 10 feet, as stated before, and the timber is only left in the 8 or 10-foot breadth for a very short time after the coal is broken down. When the coal is removed, the third row of props should be drawn and set between the other two rows, in the space which was the car road, if the car was taken along the face.

**1732.** The face packing in all longwall work is a very important matter, but in pitching seams it is doubly so. As soon as the coal is removed, the packs must be carried forwards as near to the face as they can be built without obstructing the ventilation. It is very necessary that they should be kept in a continuous line from the side of the level forwards through the work. Where, from special circumstances, it is found necessary to start new packs in the gob

during the progress of the work, it will be found advisable to build good, solid chocks as a support to the first few yards of the building.

Packs must be carefully built of the strongest available material, and each section of the packing should be carried square and solid up to the roof and securely wedged.

**1733.** In pitching seams, when faces cross the pitch diagonally and the roads are at right angles to the faces, the dip and the tendency to slip are reduced, and a certain amount of lateral pressure is carried on to the coal. Care must be taken that the lower places have a certain relative amount of **lead**, or, in other words, be further advanced (not necessarily a fast side), so that the break from the next stall above will not travel too directly on the line of the working face below as it advances, but will be steadied by the packwalls.

**1734.** The size of the packs and gobs is regulated by the nature of the roof, care being taken that they are sufficiently wide to allow the roof to break down easily. If there is not enough refuse in the seam to completely fill the gobs, wood chocks are used, which are moved forwards in the same manner as the props. If these chocks were left in, they would throw the weight of the strata above on the coal face, crushing the coal, and on the packwalls, to their injury.

The proper management of the roof or top weight in working *successful* longwall is one of the chief features of the system. The great point is to so regulate or control the pressure on the face, by means of props and chocks, that it shall be neither more nor less than enough to bring down or greatly assist the miner in mining and bringing down the web, if the coal is mined in the bottom.

#### MINING, HOLING, OR BEARING IN.

**1735.** Too much importance can not be bestowed upon this part of longwall work. Whenever practicable, the mining, or undercutting, should be made in the clay or mining dirt under the coal; but if this can not be done, it should be made in the bottom layers of the seam itself. Sometimes,

however, a more suitable place occurs on top of the seam, or it may be near the middle; but, wherever the best place exists, the miner will, if a skilful pickman, take every advantage of the natural structure of the bed he is mining in, as well as the weighting action upon the coal face, which helps to soften or break up the mining dirt as the operation of holing goes on. The experienced miner, in undercutting, takes off what is sometimes called a "skin" (6 to 12 inches in depth) as he goes along the face. This enables him to do the undercutting with very much less labor than if he were to cut the full depth under without giving the pressure time to make itself felt at a deeper distance from the face of the mining.

**1736.** A seam of coal should, if practicable, be mined or undercut as deep as it is high, and the face of the mining should be very low, so that as little slack will be made and as little labor expended on the work as possible. In thin seams the skilful miner, on account of his ability to mine deep in a holing of 6 inches high at the front, will produce from this cause alone 5 to 10 per cent. more lump coal than the inexperienced miner. Longwall mining will produce a greater yield per acre than the pillar method, and will also produce from 5 to 15 per cent. more lump coal, ton per ton, than the pillar method.

#### **ORDER OF WORKING CONTIGUOUS SEAMS.**

**1737.** The order of working contiguous seams does not admit of a general determination, as in the case of pillar work. In Fifeshire, Scotland, in many cases where several seams are worked simultaneously, the lower one is kept in advance of each succeeding seam above. In some other parts of Great Britain, where there are 105 feet between the two seams, the best results are secured when the seams are worked nearly together. In other cases, where the seams are from 30 to 40 feet apart, it is found best to work the lowest seam first and the upper seam long after; while, again, in the case of three seams having 36 and 66 feet respectively between them, it is considered best to work the seams in

the descending order, the face of the upper seam being kept not less than 30 feet in advance of the face of the lower seam. Still again, in the case of three seams parted by 72 and 75 feet respectively, it is considered best to work the seams in ascending order, and, if possible, in conveniently small districts, so that the lower seam may be completely extracted before work is begun upon the upper seam. When this can not be arranged and the seams have to be worked simultaneously, it is best to keep the face of the lower seam 120 to 150 feet in advance.

**1738.** The order in which contiguous seams are worked may affect both the roof and the texture of the coal. In gaseous seams the pressure exerted on the face of the coal greatly assists its extraction. The escape of the gas from the coal through the breaks or cracks in the intervening strata, which are caused by the removal of contiguous seams, either above or below it, and the disturbance thereby produced in the equilibrium of pressure in the strata, make the coal tougher and harder to extract. The disturbing elements between two contiguous seams are nearly at right angles to the inclination.

**1739.** The order of working contiguous seams depends not only on the ease of extraction, but on the market value of the coal as well. If the roof be injured, the result is greater insecurity, which will cause accidents if not provided against. This increased insecurity, in many cases, can be met by increased care in timbering, so that the consideration of the effect on the roof is in most cases subordinate to the effect on the coal. Where the effect is to harden the coal, the price paid the miner per ton is greater, and in the case of a soft coal the percentage of lump coal is increased.

If the increased selling price is greater than the increased cost of producing the coal, which is the case with many soft coals, the hardening is profitable. Coals which are already hard are made less profitable by a further hardening.



**1740.** The following points must be carefully considered when dealing with the working of contiguous seams:

(1) Distance between the seams; (2) thickness of the seams; (3) whether the gob is tightly packed or not; (4) nature of the roof and floor; (5) the inclination of the seam; (6) the depth from the surface; (7) the rate at which the working faces advance.

### SYSTEMS OF LONGWALL.

#### RELATIVE ADVANTAGES OF SYSTEMS.

**1741.** Longwall, like the pillar methods, has many variations; it may, however, be divided into two systems as follows:

1. Longwall advancing.
2. Longwall retreating.

These terms are self-explanatory. **Longwall advancing** simply means that the operations are begun at the opening and carried forwards towards the property limits, and **longwall retreating** means that the working face is formed at the boundary of the territory to be developed by driving main haulways from the opening, and then carrying the working face backwards towards the opening or shaft bottom.

**1742.** If the conditions for longwall working exist, and the operator can stand the early outlay for yardage which necessarily must be paid for the narrow work, then the following points may be considered in favor of *longwall retreating*, or *longwall withdrawing*, as it is sometimes called:

1. The haulage roads, airways, waterway, traveling way, etc., will be more cheaply maintained, of better dimensions, and easier to travel.
2. The risk of detrimental gob-fires will be reduced.
3. Seams high enough for mule haulage will require no taking down of top, so that the miners will be occupied in coal getting only.

4. There will be less risk of accident from falls of roof, because all work would go on beneath a solid top.

5. The coal field will be actually proved before 10 per cent. of the coal is taken out.

6. The (sometimes) disastrous effects of weight upon the gob-road packs and the working faces, due to having to leave solid pillars of coal under important surface buildings, etc., are better provided for, and are hardly felt when working on the *retreating* plan, because the crush or squeeze on the ribs and the top weight thrown upon the gob do not in any way affect the roads in the solid.

7. Main haulways liable to be blocked by extensive falls of top in gob-roads have, in the withdrawing system, every chance of being free from such dangerous and troublesome obstructions.

8. Greater ability to shut off fire, or to allow a portion of the working face to remain idle for a while without much liability to cave or cause trouble. In gob-road mining, the roof is usually so broken up back of the faces that to make a place air-tight is a matter of great difficulty.

**1743.** In some cases it is necessary to consider not only the strata directly on the top of the coal, but the strata higher up. Many times there is a frail bench on top of the coal, while the strata above it may be exceedingly strong sandstone or limestone, which, notwithstanding the seemingly nice settlement of the top, may be hanging over a large area and exerting a pressure both on the coal face and road packs, in such a way that it may be hard to contend with.

---

**LONGWALL ADVANCING.**

**1744.** In the examples of longwall working, the ventilation is shown by arrows in all plans except those which merely show a very limited portion of a mine. In the latter case it can not be definitely shown, because it is impossible to adopt an arbitrary direction for inflowing and return currents. The question of ventilation in longwall work is a

comparatively simple one, and many variations, depending upon local conditions, may be made.

**1745.** Fig. 554 shows the plan of longwall operation where the top is brittle, the pitch is from  $10^{\circ}$  to  $60^{\circ}$ ,

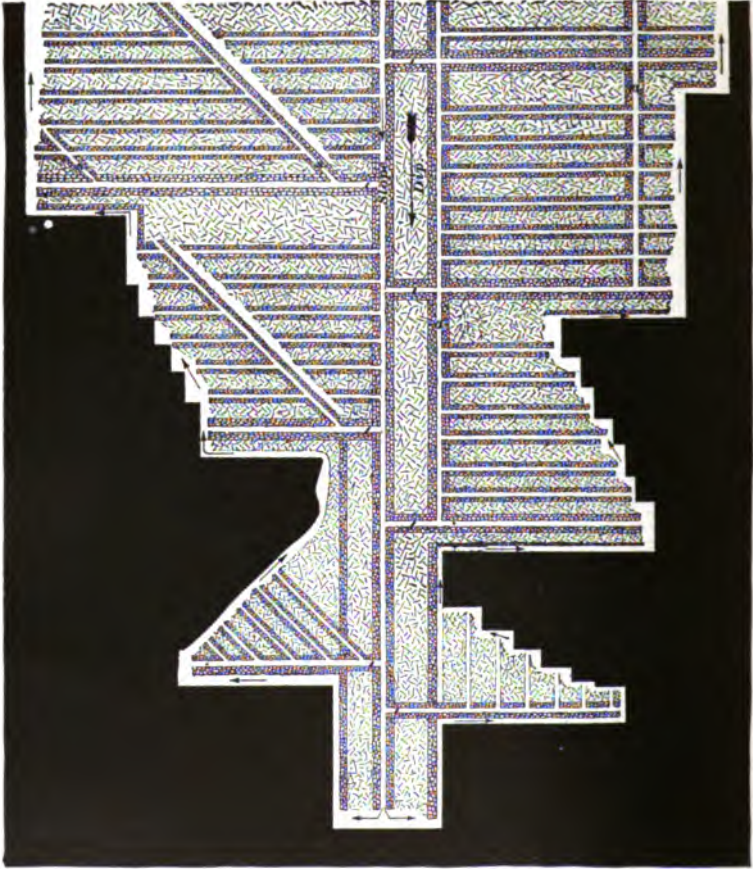

FIG. 554.

the coal does not exceed 3 feet in thickness, and there is sufficient waste from the seam and from opening up the roadways to build the packs, and, to a reasonable extent, to fill the gob.

The upper division on the left of the figure shows a plan

of operation when the pitch is such that a slope road *s* can be driven on a pitch of about  $6^\circ$ , over which the coal is lowered to the level below, which in its turn connects with the slope or heading leading to the shaft. The line of face is parallel with the dip, regardless of the line of cleat.

The second division shows the same plan, with the exception that the faces are advanced in steps, principally for the reason already given in Art. 1716.

The third division on the left shows a plan of working employed where the pitch is such that the cars may be taken to the face, where it is desirable to work the coal "half on," when the cleavage planes are parallel with the dip, or where there is no marked cleavage.

The upper division on the right-hand side shows the plan sometimes employed where the inclination is from  $15^\circ$  to  $35^\circ$ . The faces, irrespective of the line of cleavage, are driven at right angles to the dip and parallel with the level, the coal being lowered to the level by self-acting balance inclines  $\alpha$ . A chute is sometimes used instead of the balance incline.

The middle division on the right-hand side shows the same arrangement, except that the faces are advanced in steps, for reasons already given.

The third division on the right-hand side shows a manner of mining steep seams. The dip may be such that the coal is delivered by chutes or self-acting balance inclines operating in each road, or by a self-acting (not balance) incline in two roads, the loaded car going down the one road taking the empty car up the other. In the latter case there is no step between the two roads, the step being between each pair of roads.

**1746.** Fig. 555 shows two methods of circular longwall, one showing the walls, or faces, in steps (shown by dotted lines), and the other showing the wall in a continuous face. The downcast shaft *d*, the upcast shaft *n*, and the stables *h*, *h'* are all formed in the shaft pillar, which is rectangular in shape. This plan, with but few modifications, is practised in parts of the central and western coal fields of the United States, as well as in other countries. It is a good method

for thin seams with a brittle or moderately solid top. It is necessary that all places, except roadways and a narrow space along the face, should be filled close to the roof with stowed dirt and proper packwalls. It is maintained by some engineers that the packwalls should incline slightly inwards to the middle of the pack, so that when the weight comes on

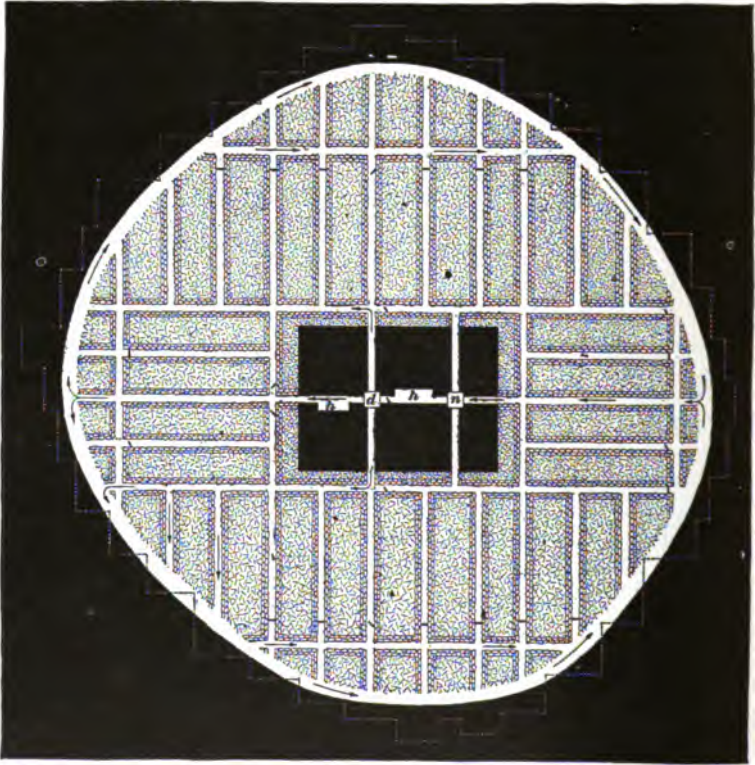

FIG. 555.

them they will not bulge out in the center. In almost all longwall work in thin seams, the height of the main roads must be maintained, after the roof has settled, by taking down top or blowing up bottom. In this case, the roadways are at first only of such a height as will give the necessary material for stowing the waste and building the packwalls.

The roof will settle in roadways from  $\frac{1}{3}$  to  $\frac{1}{2}$ , or more, of the thickness of the seam, depending on the proportion of the gobbing. The work in this figure is laid out with a view of having the same number of working faces in each direction, so that the haulage roads will be equally divided, thereby facilitating the delivery of the output to the shaft bottom. Canvas doors are used until the top has settled, when overcasts and doors of the regular pattern are used. This system is well adapted to shallow depths, where numerous shafts can be sunk cheaper than long roads can be fitted up and maintained for mechanical haulage.

**1747.** Fig. 556 shows the Missouri plan of longwall operations in seams with a strong and flexible roof, where the seam is from 20 to 22 inches thick. From the bottom of the shaft four entries are driven in the seam, at right angles to each other, for a distance of from 20 to 50 feet. This distance depends on the character and strength of the roof, the depth of the coal beneath the surface, the nature of the underlying clay, and also upon the anticipated period of operation of the shaft. From the ends of these roads cross-cuts are then driven, connecting them with each other. From the exterior sides of these cross-cuts the coal is now mined radially from the shaft, the main entries advancing with the face and being kept open by packwalls and gobbing. This process continues until the face has advanced about 800 feet, and until the distance between the ends of each two adjacent entries is about 1,200 feet. When this stage is reached, the face is still pushed forwards in the same direction as before, but, instead of one entry being left open and packwalls built, two are now left, which radiate from the main entry, one on the right and one on the left, each at an angle of  $45^\circ$  with the original direction of the main entry. In the angle between these two new entries a triangular packwall is built, as a permanent pillar, and beyond it the mining of the coal continues as before. When this has proceeded to such a distance that the haul along the face of the coal to the entries again becomes excessive,

bifurcation (dividing into two prongs or forks) of the entries is again resorted to.

The process continues until the limits of the property are reached, unless the coal is at such a shallow depth that it is more economical to sink new shafts than to have a long underground haul.

Part of the shaft *s* is used as the downcast airway, and as

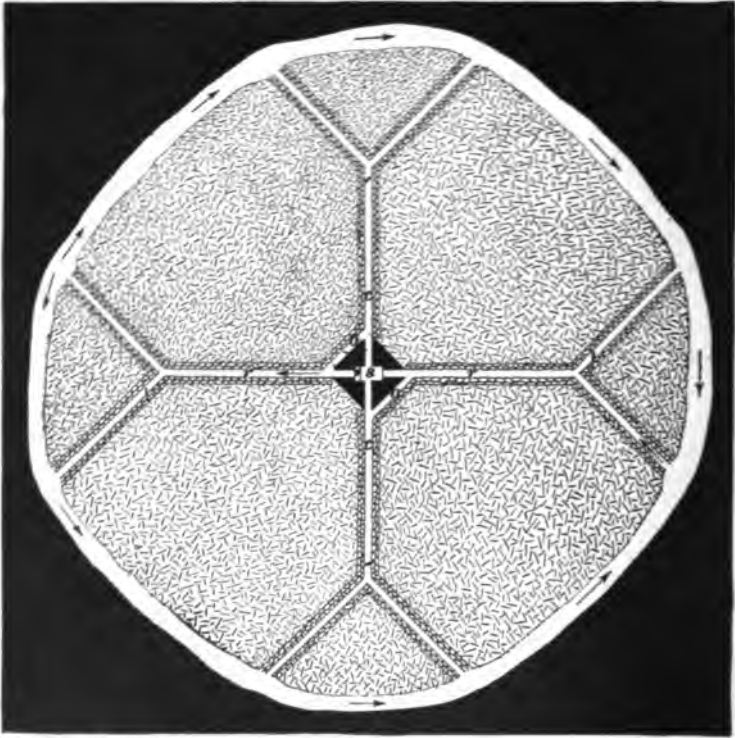

FIG. 556.

the caging is usually done on two opposite sides it is necessary to leave passages *o* on two sides of the shaft pillar in order that the cars may be taken from the roads *r* to the roads *c*, where they will be in the proper position for caging.

Of course it is understood that the track is laid along the

working face between the entries and is moved forwards as the coal face advances.

The coal is undercut to a depth equal to its height along the whole face, and is wedged down or pressed down by the weight of the superincumbent strata. A certain length of face is assigned to each miner. The general conditions are

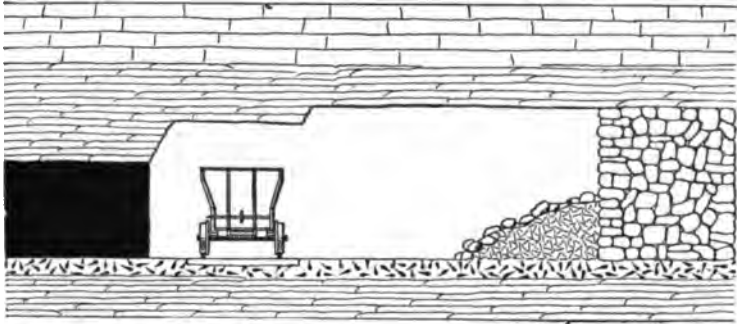

FIG. 557.

illustrated in Fig. 557, which is a section of the seam parallel with one of the packwalls.

As the coal itself is not high enough for passageways, and because material is needed for packwalls, the floor is taken up and the roof is taken down. The main roads vary from 4 feet high by 4 feet wide to 8 feet high by 12 feet wide, depending mostly on the nature of the top. If the roof is of solid limestone, sandstone, or even a strong slate, the road may be almost any width desired. In the roads which are only used temporarily the height is from 3 to 4 feet.

The method of supporting the roof is shown in Fig. 558.

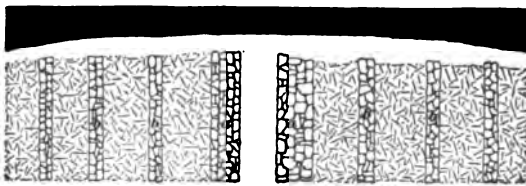

FIG. 558.

One heavy and well-built packwall *a* is carried along by the



miner on each side of the entries, and between these continuous pillars, less carefully packed walls *b* are carried along at right angles to the face as the work advances. These pillars are built of the heavier and larger blocks of waste material, and in between them the smaller and loose material is shoveled. The distance between the pillars is about 6 feet, and the smaller pillars are themselves about 2 feet wide and are tightly wedged to the roof.

**1748.** Fig. 559 shows a method of longwall pretty much the same as shown in Fig. 555, and much in practice in the

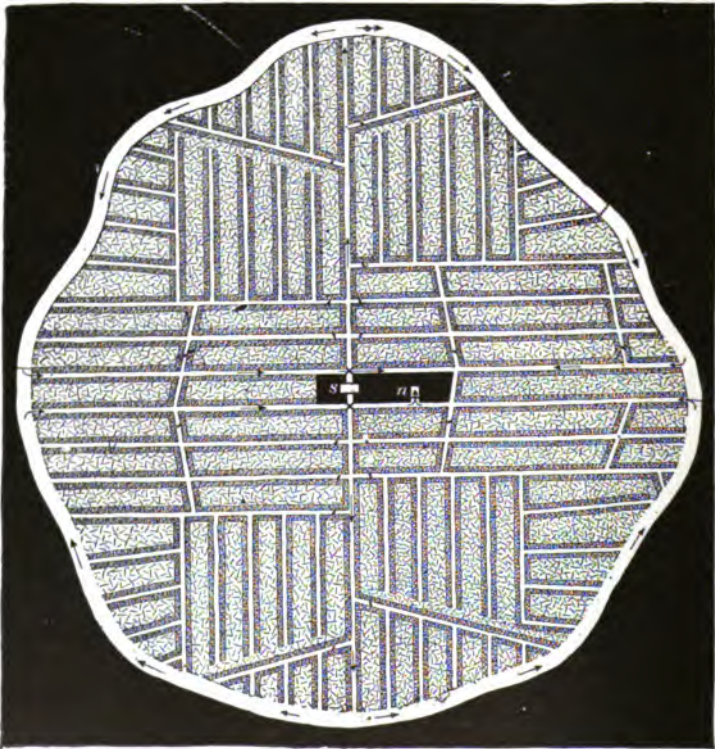

FIG. 559.

central and western coal fields of the United States. It is considered a good plan for low flat seams having a weak and

brittle top. In this plan so much space can not be maintained between the face of the coal and the packs as in Fig. 556. The coal is removed directly through numerous roads which connect with one of the principal entries. From the foot of the shaft *s* entries are driven in opposite directions. As soon as sufficient length of face is exposed for mining operations to proceed, the coal is attacked on both sides of the entry along the whole length. As the face advances, the waste material or gob is thrown behind, and at the same time roads are made with packwalls on both sides, at intervals of about 40 feet and at right angles to the main entry. Between two passages or roads, along the main entry, walls of packing are carefully built. The interval between two such roads is known as a "room," and is generally operated by one miner. A careful inspection of the figure will make the system clear to the student. At Leavenworth, Kansas, the dimensions of the main roads are 5 feet wide at the base, 4 feet wide at the top, and 6 feet high, the coal being 22 inches thick.

In this case, packwalls are carried along the entry sides, and on each side of the room road props are placed.

It is the practice, sometimes, to leave a small pillar of coal around the hoisting shaft *s* and sink the air shaft *n* in the gob. When this is done the air shaft is supported at the bottom by carefully built packwalls and stowage. Frequently, after the mine has been fairly developed, it will be found that more efficient ventilation can be obtained by sinking a shallow shaft some distance away from the hoisting shaft, in which case the new shaft will almost invariably be sunk in the gob. Otherwise, it is generally conceded best to leave a pillar of coal to support the shaft, because there is less liability of destroying its alinement through neglect or carelessness of any kind.

**1749.** Fig. 560 shows a plan of longwall work suitable for seams at great depths, ranging from 2 to 9 feet thick, of almost any texture, and with slight modifications for almost all kinds of top, although best results are obtained when the top is not very weak, and the dip ranges from 14° to 20°.

After the preliminary headings necessary for shaft pillars, ventilation, and drainage have been made, sufficient coal is worked out to allow first packwalls to be built, and from this point the face line is maintained nearly at right angles with the full dip. Two lines of track are laid to facilitate the loading, and in the case of the thinner seams, a slant to

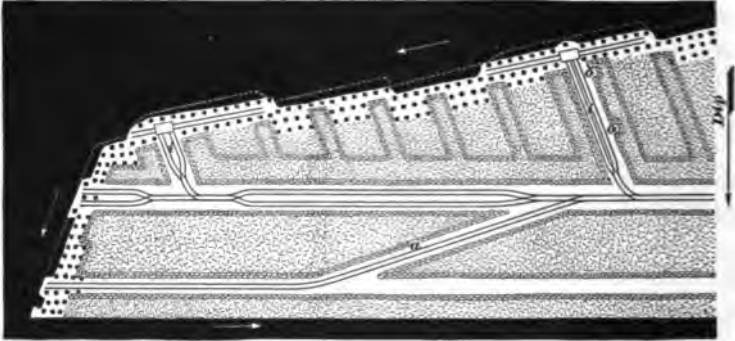

FIG. 560.

be worked by a mule is packed in as shown at *a*. In the case of the thicker seams the road *a* is not driven, and a hand winch is used to raise the coal from the dip side of the level to the level road at the face.

Special attention must be paid to the building of the first packwalls, as it is found that when the roof cuts off at the edge of the solid coal in the level, there is usually more subsidence than in the ordinary working.

**1750.** The first packwalls in the thinner seams may be built with *débris* brought from other parts of the mine or with material taken from the top or bottom of the roads in the solid. As soon as a sufficient length has been built, taking down top in the level is commenced. About 5 feet of roof is taken down in a seam 4 feet thick, care being taken not to take it down in advance of the packs, in order that the top rock will not be shattered over the position of the packwalls. Excepting where the workings are disturbed by subsequent operations, in overlying or underlying seams, very little further work is required in the main road unless

it is the taking down of a small thickness of roof, fractured by the blasting in the first operation.

Chocks, or wooden packs, are built 3 feet square, on the high side of the road, at intervals of five yards. The pack-walls throughout are built in sections of 4 to 5 feet in length, and crosswalls at right angles to the roadside are thus formed, which are a most important factor in securing the sides of the level. Offsets or manholes *o* are built in the side of the inclined roads to afford safety to the men while traveling therein.

In the case of thicker seams, that is about 7 feet thick, no ripping or taking down of top is done in the forming of the levels, and the whole of the packing must be made with the *débris* brought from other parts. And, as packs 7 feet high are not sufficiently stable as a rule for the rise side, it is found advisable to leave from  $2\frac{1}{2}$  to 3 feet of coal over the pack; this allows the necessary amount of subsidence to take place.

As soon as possible a temporary, self-acting incline *i* is put to work; and, for reasons which will be stated later, it is necessary to work the face to a certain extent concurrently with the opening out of the levels. It is not, however, advisable to carry on the regular working of the coal until a sufficient length of face has been opened out, because it will be difficult to keep the continuous line and direction required in order to work the system to the best advantage.

**1751.** The length of the working face varies with the thickness of the coal, the rule followed being that sufficient length of face is given each set of miners to allow a web (a mining) of coal to be taken out every week, or thereabout. The men work in sets of 6 or 8, two being loaders. Starting at the "road-end," or "road-head," the coal is taken down in one direction, and as soon as sufficient length of face is stripped, mining, or holing, is recommenced. There is practically no blasting of the coal, as it is found that where the packing and timbering is properly done the coal is broken at the back of the mining by the weight of the super-

incumbent strata. The dotted line shows the form of the face when the rear row of props will be advanced.

**1752.** As was mentioned before, packwalls on the high side of a roadway, and especially levels, are in a position where the tendency of the broken roof to slip downwards is first felt; and, unless proper precautions are taken to prevent that movement, they are likely to be pushed out. The essential points to be considered in this respect are:

1. That a sufficient breadth of coal is taken out below the side of the level, and the space thus made well packed.
2. That as the line of coal face progresses, steps are taken to continue the high side working as soon as possible.
3. That the high side packwall is so built that the pressure of the roof is met by greater resistance on the side of the level than on the portion of the same packwall nearest the working face.

**1753.** In deciding what breadth of coal should be worked on the lower side of the level, it is necessary to be guided largely by the direction of the first breaks in the roof, both on the rise side and the dip side of the opening out places. It is generally found that the direction of these first breaks varies considerably from the direction of the main break. The reason that it is necessary to consider the direction of the first break rather than the main break is because the fracture of the roof takes place soon after the packwall is built, and, therefore, any general pressure due to a uniform subsidence has taken place. The packing, however carefully built, is not in condition to meet sudden or violent disturbance.

**1754.** Fig. 561, which is a section of a longwall working having two parallel levels, is taken to illustrate the advantages of taking out a sufficient breadth of coal from both sides of a level. Suppose the coal was taken out below the level  $r$  to the point  $c$  and to the point  $n$  above, then the directions of the first breaks will be  $ca$  and  $ab$ , leaving no lateral support to the mass  $abf$  when the top is taken down

in the level. This mass then has a tendency to slip down hill. It will also be noticed, by referring to the figure, that slipping will more readily take place if a sufficient breadth of coal were not worked out on the high side of the packwall, and if the first break should take place in the line  $g h$ .

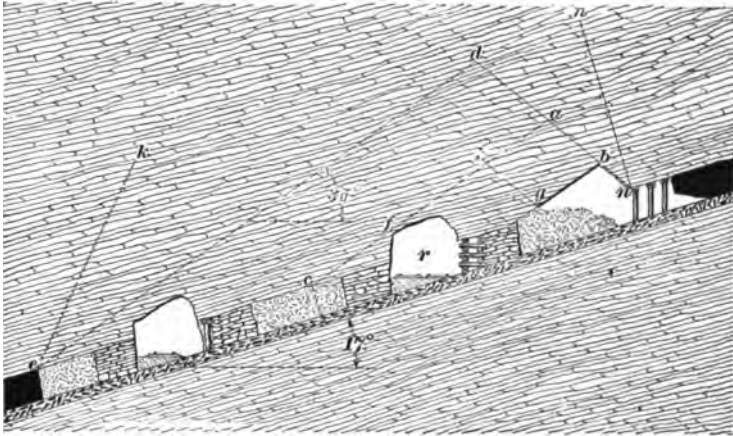

FIG. 561.

When sufficient breadth of coal is taken out on both sides of the roadway to cause the break to take the lines  $b d$ ,  $d c$ , there is sufficient lateral support left in the loosened mass of roof  $b d e$  to prevent the downhill slipping, and at the same time the greater weight of that portion directly overlying the high side packing tends to exert a directly vertical pressure. The lines  $e d$  and  $d b$  show the direction of the first breaks, while the lines  $c k$  and  $n m$  show the direction of the main breaks.

**1755.** Fig. 562 shows a method of longwall which is largely practised in low seams, in which the regular mine car can not be taken along the coal face. The roadways  $r$  are turned off the heading or haulway  $h$  at intervals of about 30 yards, and when they are driven up 10 yards, lifts of 8 or 10 yards are turned off to the right and left and driven parallel to the heading for 15 yards, or one-half the distance between the roadways. Two men at a time work in each

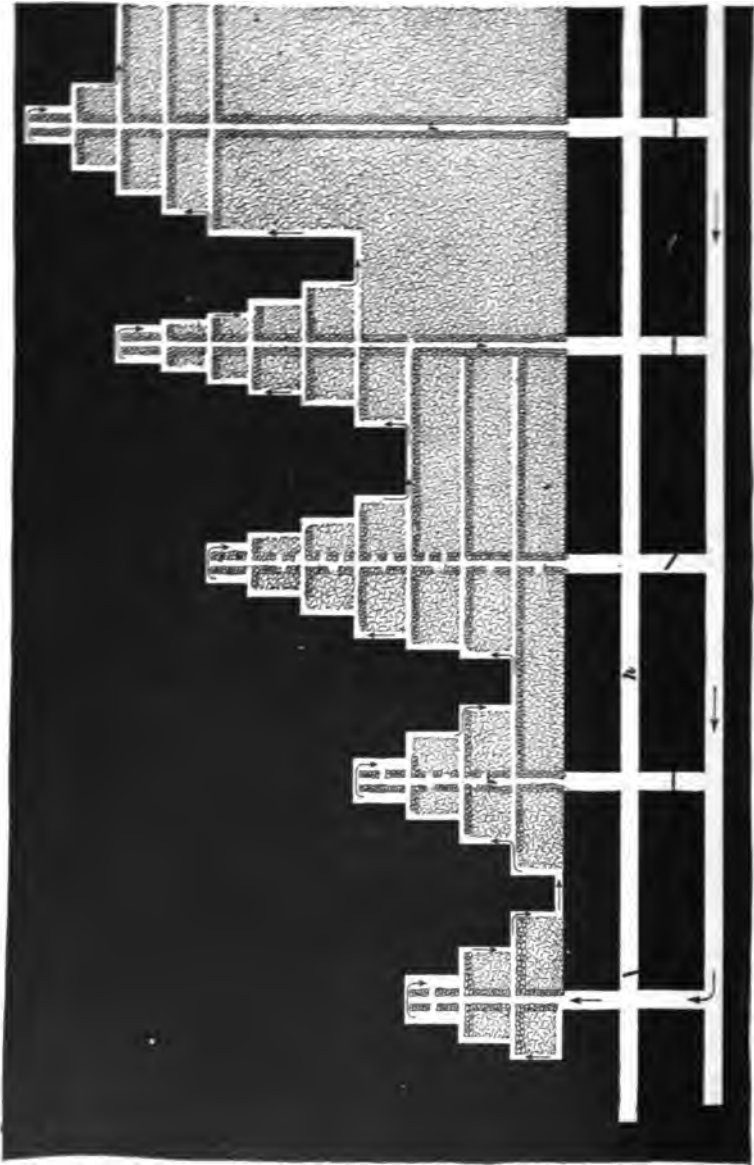

FIG. 561.

lift. Sometimes the roadways are turned off at intervals of only 10 or 12 yards, in which case the coal is filled directly into the cars without the use of buggies to convey the coal to the road side, as is done when the distance between roadways is 30 or 40 yards. Packwalls 6 feet wide are built along each side of the roadways and on but one side in the lifts, as shown in the figure.

When the roadways are close together this system entails a great amount of extra cost in building packwalls and taking down roof, which brings the price paid per ton up to that paid when the pillar and chamber method is used; but, since more lump coal can be produced by the longwall method, the advantage is in its favor, and it is therefore adopted. The cleavage planes are parallel to the dip.

One objection is that under a fairly strong top the packwalls are so close together that sometimes the top does not fall, and when there is not enough refuse to thoroughly stow the open space, or gob, these packwalls become a source of trouble and danger, especially in gassy seams.

**1756.** Fig. 563 shows a method of longwall as practised at Pemberton Colliery, in Lancashire, England. The seam dips at an inclination of  $4^{\circ}$  to  $5^{\circ}$ . Two seams are worked; the one from which the example is taken is 1,698 feet from the surface, and the other is 180 feet below it. The coal from the upper seam is lowered to the lower seam through a pit called a **blind pit**, with two cages, the rope going over a clip pulley. One car is lowered at a time, the full one pulling the empty one up. The coal is brought from the level next the face to the top of the blind pit by means of a self-acting incline.

The roads  $r$  are driven to the full rise and are 30 yards apart from center to center. They are cut off every 300 feet by levels  $\ell$  running about at right angles to them. These levels are 8 feet wide and have packs 12 feet wide built on each side. The roads to the faces or "brows" are 7 feet wide and there are 9-foot packwalls on each side (see Fig. 565). Two feet of top is taken down in the roadway for packing.



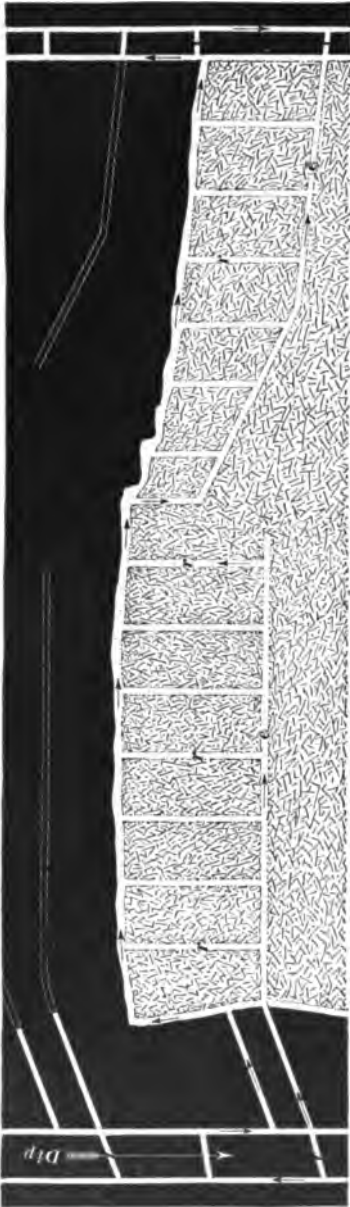

FIG. 563.

There is no regular holing or mining, but when the coal is mined it is done in the 10-inch coal in the center (see Fig. 564). The bottom coal is then lifted up and the top coal supported on props. When these are knocked out the top coal falls. A slight heaving of the bottom greatly assists in taking up the bottom coal. Props and sprags are put in by the miner when required. Four men are in the place on each side of the road, and they deliver their own coal to the self-acting incline.

**1757.** In addition to the 9-foot packwalls carried on each side of the roads to the face, a double row of chocks *c, c* (Figs. 564 and 565), 6 feet apart, is carried all the way along the face. The two rows are laid 5 feet apart, and the car track along the face is laid between them (see Fig. 565). As a third row of chocks is put in, the last one is drawn and shifted forwards. The roof then breaks off behind the chocks. Each chock consists of billets

of wood 2 feet long and 6 inches square, and requires about 5 minutes of one man's time to erect and wedge tight.

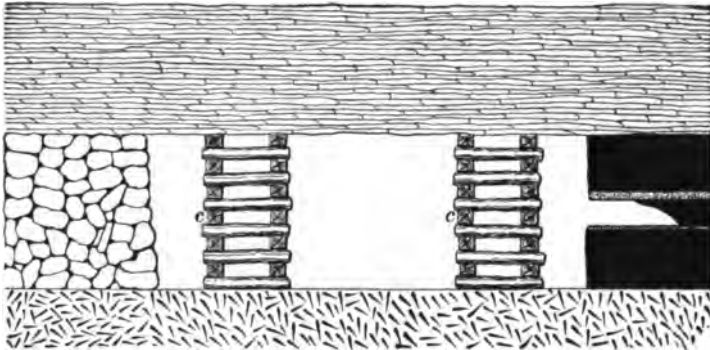

FIG. 564.

They are set on fine dirt or slack for the purpose of being easily removed and distributing the weight equally upon them all.

This system of driving pairs of headings in advance of the

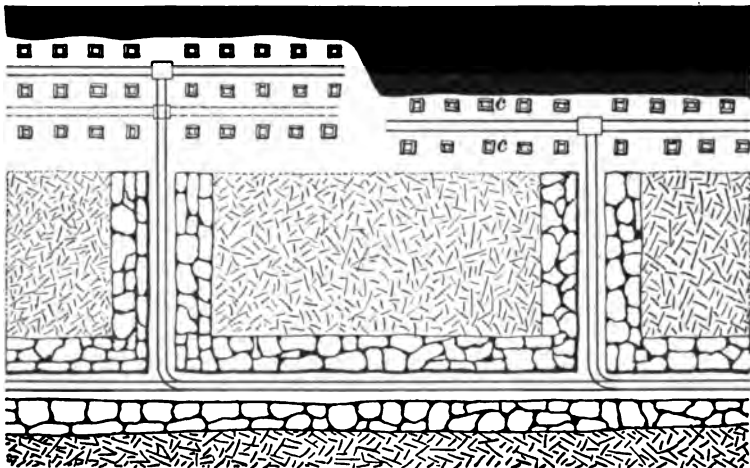

FIG. 565.

range of rooms is used for the purpose of proving the territory ahead of the main workings, or when old workings full

of gas or water under great pressure are being approached. The method also localizes the workings, which, like the panel system, is an advantage in gassy mines; but most of the coal in the pillars protecting the headings, and which is drawn when the boundary of the district is reached, is seriously crushed.

**1758.** Fig. 566 shows an ideal plan of the longwall method employed at High Part Colliery, Langley Mills, Not-

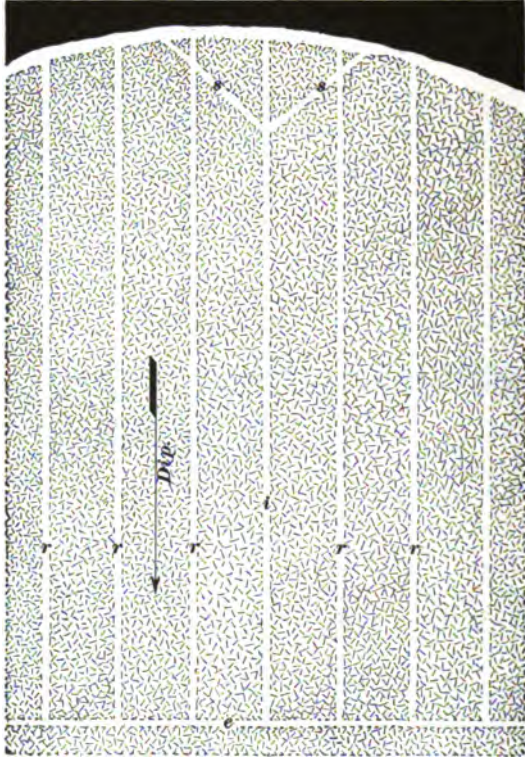

FIG. 566.

tinghamshire, England. The seam is at a depth of 600 feet, and has an inclination of about  $3^{\circ}$ .

The distance from center to center of the room roads  $r$  is about 150 feet. These roads run up hill, and are cut off every 1,200 feet by a slope road  $s$  from the one used as the

main road or self-acting incline plane *i*, down which all the coal is sent to the level *c*. Three feet of the shale roof is taken down in the roads. Below the 2 feet of fireclay in which the holing is done, directly beneath the coal, there is a dark sandstone. The seam is 5 feet 2 inches thick and composed of several layers varying from each other in thickness and quality.

**1759.** The packs are within 4 feet of the face when the holing or mining is begun, and there is a row of 8-inch props  $4\frac{1}{2}$  feet apart along the face. The miners begin at the center and go on holing to both sides, putting in sprags *b* (Fig. 567), 2 feet long, every 6 feet. When necessary, short sprags *a* (Fig. 567), about 15 inches long, are put in

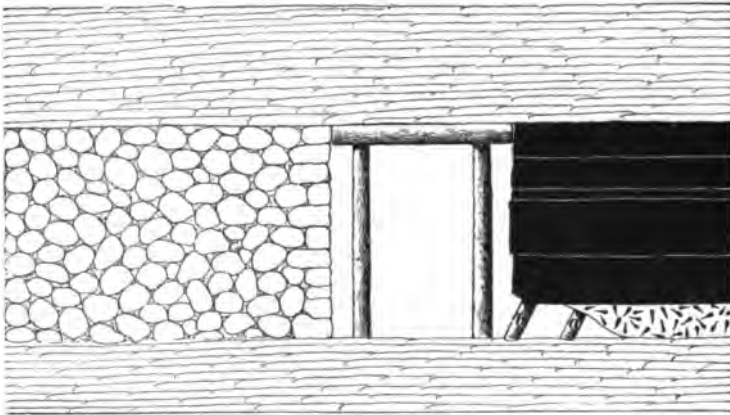

FIG. 567.

underneath the coal, but there is no fixed distance that they should be apart. While the coal is standing on sprags a **shearing** or vertical holing is made at the road-head, 2 feet wide at the beginning and tapering to 3 inches at a depth of about 5 feet. After this is done the miners begin by taking out three or four sprags, and allow the coal they supported to fall.

This is loaded and the roadway laid along the face as shown at *r*, in Fig. 568, which is a plan showing two adjacent

rooms with packwalls and posts. Props and sets of timber are set up over the road (see Fig. 567) about every  $4\frac{1}{2}$  feet. One end of the cross-bar is sometimes let into the coal some 3 or 4 inches, and the other end is supported on a prop. When this is done other sprags further on are taken out and the

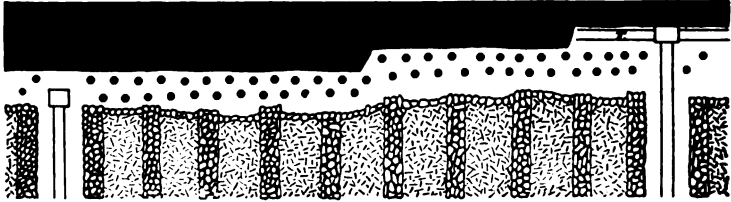

FIG. 568.

coal is loaded. The process is repeated until the end of the room is reached on both sides. When there are two rows of props which are about 5 feet apart behind the sets of timber over the road, the packwalls are built forwards and the props removed. Where the roof is weak or tender, packs about 6 feet wide and 9 feet apart are built of the débris from the road.

**1760.** Fig. 569 is reduced from the working plan of the Florence Colliery, Longton, in the North Staffordshire

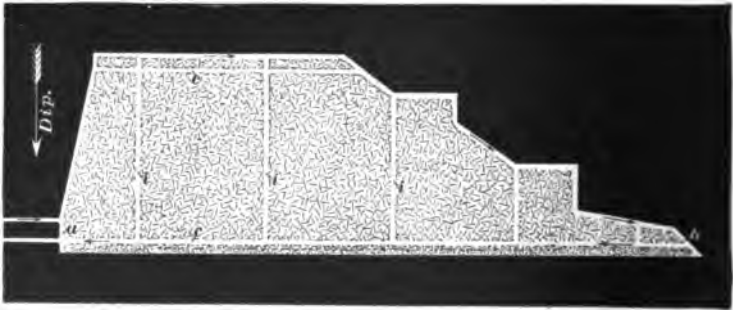

FIG. 569.

(England) district. The depth to the coal is 2,238 feet and it has an inclination of about  $8^\circ$ . Two levels, 10 yards apart, are driven from the shaft bottom for a distance of 1,050 feet, to

point *a* on plan, and at this point a width of 75 feet of coal is taken out. A gob-road *c* is constructed in it, with about 12 feet of packwall on the dip side. The wall, or line of faces, is started from this road, and each face is 254 feet wide, with a road *i* up the center. These roads are cut off by a level *e* every 360 feet. The faces are not all in line, but some are stepped, the one being 45 feet to 60 feet ahead of the other. There is a self-acting incline in each road by which the coal is brought down to the level *c*. It is then drawn along the main level by horses. Chains are used on the inclines.

The roof is 8 feet of fireclay overlaid by a bed of coal

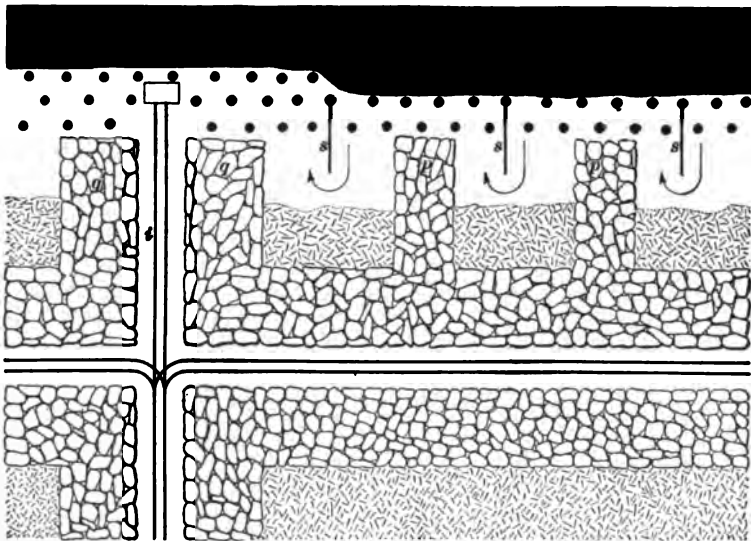

FIG. 570.

2½ feet thick, above which are beds of fireclay and hard, dark shale 8 feet thick, then 8 feet of coal and partings, and then 32 feet of hard, black, slippery clay. The floor is 37 feet of hard shale. The breasting *b* at the face of the level is 75 feet wide, and is kept advanced for opening up fresh roads. Buildings, or packwalls, 9 feet wide, are made along both sides of the roads, which are each 6 feet wide. The arrangement of the props at the face is shown in Fig. 570.

**1761.** The buildings, or packwalls, are extended every 5 feet, and the rear row of props extracted and advanced. A sprag *a* (Fig. 571) is put under the coal every 6 feet, as the holing is made, and frequently before holing, **cocker-megs** are put up along the face. These cockermegs consist of poles *c* (Fig. 571) laid horizontally along the face about 2 feet from the bottom upon short struts *d*, and tightened by other longer struts *b*, one end of each being let slightly into the roof, and the other placed upon the horizontal pole and then driven to place. The space between the packwall on the low side of the level *c* (Fig. 569) and the ribside is kept open as long as possible, and when this can no longer easily be done, a hole is driven through the packwall and a fresh-air course is kept up from this point. There is a chock made of broken timber put up at the corner of each hole. These holes are made about every 120 feet.

The ordinary rooms are 254 feet wide, and 9-foot packs *p*, *p* (Fig. 570) are built parallel to the road 21 feet apart. The packs *q*, *q* next the road are 12 feet wide and are built of stones from 3 feet of brushing, or top, taken down in the

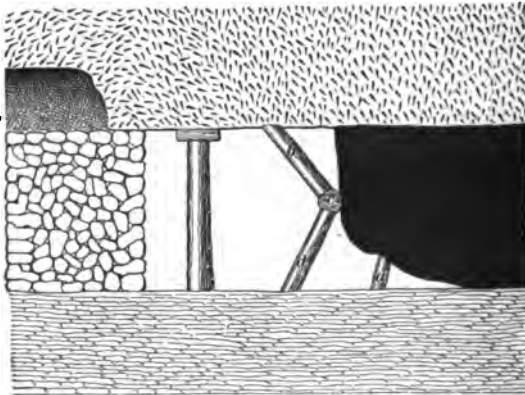

FIG. 571.

road. If this does not furnish sufficient stones for the packs, stones are drawn out of the waste where the top has broken.

After the holing is completed the sprags *a* (Fig. 571), and cockermegs, when used, are drawn and the coal is broken

down by blasting. The props are from  $5\frac{1}{2}$  to 6 inches in diameter at the thin end, and there are two rows  $4\frac{1}{2}$  feet apart with the props in each row 6 feet apart. If the roof is tender, chocks made of broken timber and built on small coal are put in. There are canvas sheets *s* (Fig. 570) put in from the face for some distance back into the wastes, or gobs, between the packs, and the air is made to travel into the gob.

**1762.** Fig. 572 shows a system practised in Northern France and Belgium in seams pitching from  $10^\circ$  to  $60^\circ$ , but it is most suitable for pitches ranging from  $30^\circ$  to  $60^\circ$ . The more moderately inclined seams are worked by a road carried up from one level to another, and branch roads are turned off right and left from it about every 20 yards, measured along the inclination of the seam. The coal is taken out for a distance of from 150 to 300 feet on each side of the main incline *i*, and the face presents a series of steps. At intervals slope roads *s* are formed through the gob, cutting off

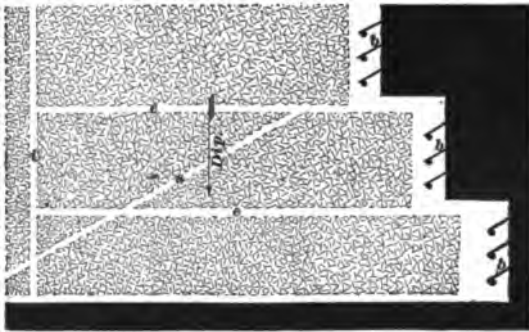

FIG. 572.

the upper levels. When the inclination is  $30^\circ$  to  $60^\circ$ , the track is only laid along the main levels *e*, *c*, which connect with a main self-acting incline *i*. The coal, when loosened by the miner, gravitates down to these levels along the face, and is there loaded into cars. Each face is 60 feet long (measured on the dip), and is worked by four men. For convenience and safety, these men place pieces of board *b*



across the floor horizontally from prop to prop, or face to prop. This also enables the miner to partially regulate the descent of the coal along the face. On moderate pitches slope roads are used, while on steep pitches the incline is used.

**1763.** Figs. 573 and 575 show the longwall methods of mining two seams simultaneously at Niddrie Colliery, near Edinburgh, Scotland. The coal has an inclination of from  $50^\circ$  to vertical. This colliery was formerly operated by the "stoop and room" method, or a form of it called in Scotland "room and rance," but at a depth beyond 720 feet the difficulties in maintaining roads and getting the coal from the stoops, or rances, increased so rapidly that longwall had to be applied.

The general nature of the workings where the dip does not exceed  $70^\circ$  is shown in Fig. 573, in which *A* is a plan or a horizontal projection of the workings with the strata above the line *uv* on section *C* removed. *B* and *C* are sections through the plan *A* on the lines *mn* and *xy*, respectively. In describing the figure each of the several views will be referred to as marked. Narrow levels *ab, cd* (*A* and *B*) are driven in the solid in both the upper or "great" seam and the lower seam from the winding incline *ii* at a depth fixed upon as the bottom of the lift. When a sufficient distance has been reached to ensure the safety of the incline, they are connected by a cross-cut *bd* (*B*) in the rock, and the longwall work is commenced. Section *C* shows that the longwall working in the lower seam is commenced beyond the cross-cuts *bd, lo*, and *qp*. A level *be* (*A* and *B*) is started usually 24 feet wide, having 6 feet of stowage under the rails. The rise side is pillared continuously with wood, the pillars 3 feet thick built checker-board fashion, the open space between being filled with slack.

Chutes *s* (*A*) are branched off, straight to the rise, at intervals of from 24 to 48 feet between centers; they are from 3 to 4 feet wide and are made with concave floors of iron-stone and other hard strata. The gob is stowed with the slack, soft fireclay, and any iron-stone not required for

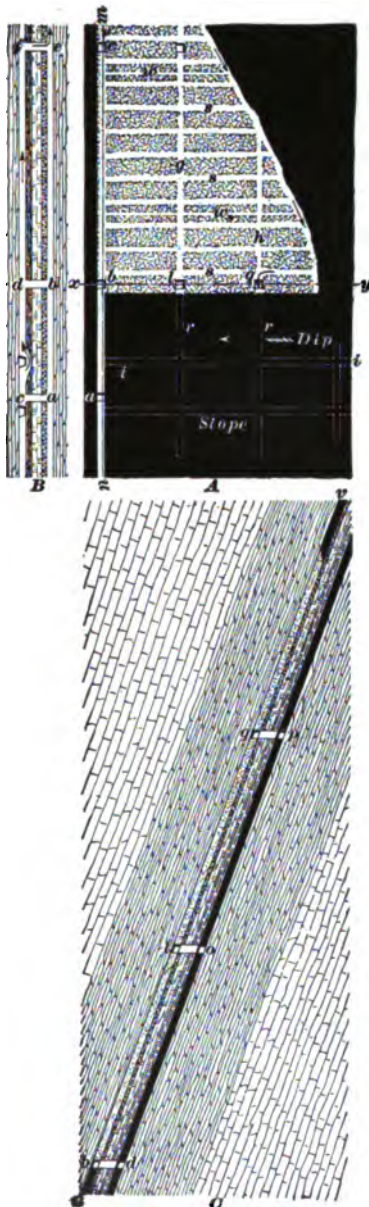

FIG. 87a.

packwalls. For the convenience of the miners the walls are arranged so that each has a long rise and a short dip side. The coal is dropped down the chute, at the bottom of which it is loaded into cars.

At intervals of about 210 feet traveling roads  $w$  ( $A$ ) are formed for the purpose of affording convenient access to the working face at different points. These are built similar to the chutes and are furnished with ladders.

While the longwall working is progressing, roads  $r, r$  ( $A$ ) are driven in the lower seam, at intervals of about 120 feet, and cross-cuts  $o l, p q$  ( $C$ ) are driven therefrom to the great seam, so as to strike this seam before the longwall heading reaches their level. From these cross-cuts intermediate levels  $g, h$  ( $A$ ) are carried across the working faces as they come up, cutting off the chutes. The roads for these immediate levels are laid upon the stowage, and the rise side of the roadway is pillared with wood as in the level below.

The level  $d f$  ( $B$ ) in the

lower seam is carried in the solid in advance of the long-wall in the great seam. From it cross-cuts  $f e$  ( $B$ ) are driven connecting the two seams at intervals of 360 to 480 feet for the purpose of cutting off the outside portion of the great seam level as soon as the chutes in it have been cut off by the intermediate level above. The same system is followed with the upper levels, the object being to shorten the life of the roads in the great seam, and to keep the horse or mechanical haulage as close to the working face as possible.

**1764.** The method of building the levels and chutes is shown in Fig. 574, in which  $A$  is a plan or horizontal projection taken by supposing all to be removed above the line  $m n o p q$  shown on section  $B$ , which is taken along the line  $w x y z$  on the plan  $A$ .

The stowage on the dip side of the level tends to prevent the roof breaking and bursting out in the road. Where the seam yields water, drainage is provided for by placing the large blocks of iron-stone and other hard strata at the bottom of the stowage. The top coal is usually taken down in the level, as it is considerably crushed by the roof weight, and when it bursts out it is almost impossible to secure it again. The roof is supported by ordinary half-round bars or slabs  $d$ , 8 feet long, placed 4 feet apart between centers, and carried by 5-inch props at each end. In some cases a piece of pillar wood or plank is laid longitudinally among the stowage, and the lower end of the crown or cap  $d$  is driven down between it and the roof, the upper end being carried by a prop  $a$ . This is found to steady the roof until it has come to rest upon the pillars and stowage.

**1765.** The pillaring consists of any description of wood that can be obtained cheaply, not less than 3 feet long, and for convenience in building it should be hewed on two sides. The mode of building is as follows: A temporary scaffold is formed of 1-inch bratticing boards about 4 feet long, carried by two props set at a little above a right angle to the plane of stratification, and slightly set into the roof and

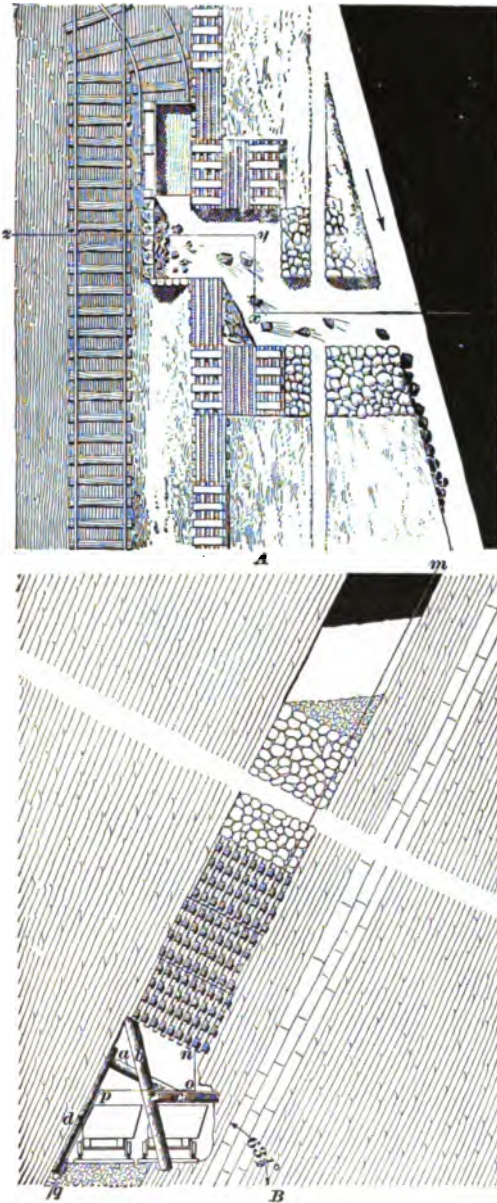

FIG. 674.

floor. Upon this scaffold the pillar is built in alternate courses of header and stretcher, commencing at the pavement, and continuing up to the roof, where the last course is driven in tightly. Each chock, or pillar, is filled with slack and fine dirt, experience having shown that a pillar of this nature affords a better support to the roof and is less liable to cause it to burst out in the roadways than one built solidly with timber. As soon as the roof weight is seen coming upon the scaffolding props, they are knocked out and the scaffold taken down, the pressure upon the pillars being then amply

sufficient to hold them in position. Many hundreds of these pillars have been put in, and they have never been known to slip.

As soon as the chutes *s* (Fig. 573) in a section of a level, as *b c*, in the lower level, are cut off by the level *g* above, the pillaring is taken out in the corresponding section *b c*, and the wood so drawn is used a second time, and, when used in connection with a little new wood, even a third time.

**1766.** The distance between levels is determined chiefly by the inclination of the seam and the condition of the packwalls of the chutes. As the inclination increases, the coal falls down the chute with greater velocity, and the breakage, consequently, become more serious. The iron-stone with which the chutes are built varies considerably in strength, in some places forming very indifferent building material, and when the packwalls begin to give way, the expense of repair is very great. It, therefore, becomes simply a question of arithmetic at what point the reduced value of the output, together with the cost of maintenance of chutes, will warrant the outlay for a new cross-cut and intermediate level.

The shield, or battery, *b c* (Fig. 574) stops the coal at the mouth of the chute, protects the men while passing, and makes a convenient platform off which the coal is loaded into the car. It will be noticed that the battery closes the chute on the outer side. Experience has shown that, when it is so arranged, the air current is much more easily led into the face of the level, and is less dependent upon the screen-doors, which, it is needless to point out, are exceedingly difficult to maintain in perfect condition. The coal is generally worked in lifts of from 360 to 480 feet, and is divided into panels of about 1,200 feet in length.

**1767.** The plan shown in Fig. 575 is used very successfully on pitches ranging from  $70^{\circ}$  to  $90^{\circ}$ . The brake incline and haulage roads are made in the lower seam, as in Fig. 573. Narrow levels *b* in the solid are branched off this incline at

intervals of 56 feet between centers, and from each level a cross-cut *c* is driven to the great seam. The longwall working is commenced on the bottom level, 6 feet of stowage is kept below the rails, and the rise side of the road is pillared continuously, as already described in Art. 1763. The clear height of the road is  $5\frac{1}{2}$  feet. The rise side of the working face is kept trailing, so as to form an angle of  $45^\circ$  with the road. As soon as this level has been opened up

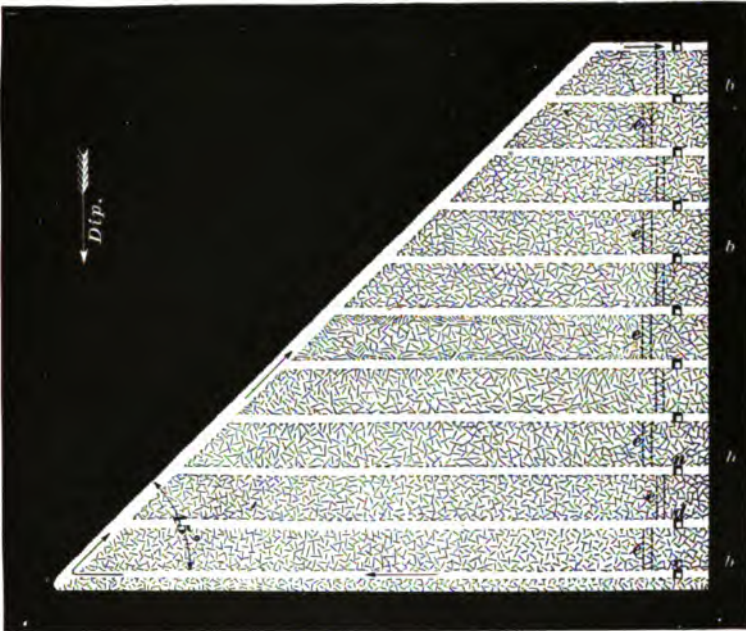

FIG. 875.

sufficiently to let the rise side reach the level of the cross-cut *d*, a road from this cross-cut is laid on the top of the stowage, its rise side being pillared in the same manner as that of the lower level, and the working is extended upwards to the cross-cut *n*, and so on to the top of the brake incline.

The bottom coal generally stands well enough in the roads without timber. The roof, which here forms one side

of the roadway, is supported where necessary with half-round crowns, or caps  $8' \times 4' \times 4'$ , placed 4 feet apart. The upper ends of the crowns are built into the pillaring, and their lower ends are buried in the stowage. As already stated in Art. 1766, brake inclines are usually about 1,200 feet apart, and from each the coal is worked for a distance of 600 feet on each side. As soon as a road reaches the boundary of the panel, and is thereby cut off, the pillaring is drawn from the coal underneath, and again used, as already described. Communication between the different levels is obtained by means of traveling roads *e* formed in the lower seam and fitted with ladders.

To one not accustomed to edge seam mining, it may appear to be a somewhat dangerous method of working, but experience has shown that this is not the case; and while under the old system of stoop and room it was frequently difficult to get a sufficient number of men for drawing pillars, there is now no difficulty in obtaining men for the longwall workings.

**1768.** In Nottinghamshire, England, two seams separated by only 7 feet of strata are worked together. The lower seam is 7 feet thick, the seam above is 2 feet thick, and they dip about  $3^\circ$ .

The main levels are driven from the shaft in the lower seam, and the gob-roads are driven at distances of about 180 feet apart, a pillar of about 90 feet being left next the

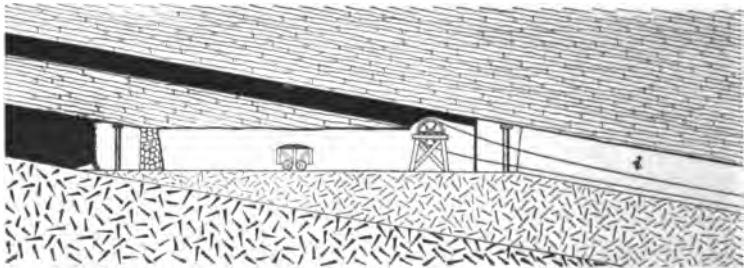

FIG. 576.

level. The lower seam is worked first, and when the workings have advanced about 90 feet, the intervening strata are

taken down, and the débris then acts as a flat at the top of the inclined roads in the upper seam. The position of these seams, and the mode of working them, which is shown in Fig. 576, makes a most convenient flat at a small cost. The cars from the second seam join those from the larger seam at the top of the self-acting incline plane *i*.

**1769.** Where the seams are highly inclined, very much contorted, and broken up, it is the practice in some districts to sink a vertical shaft *s* (Fig. 577) and drive cross-cuts *c* at

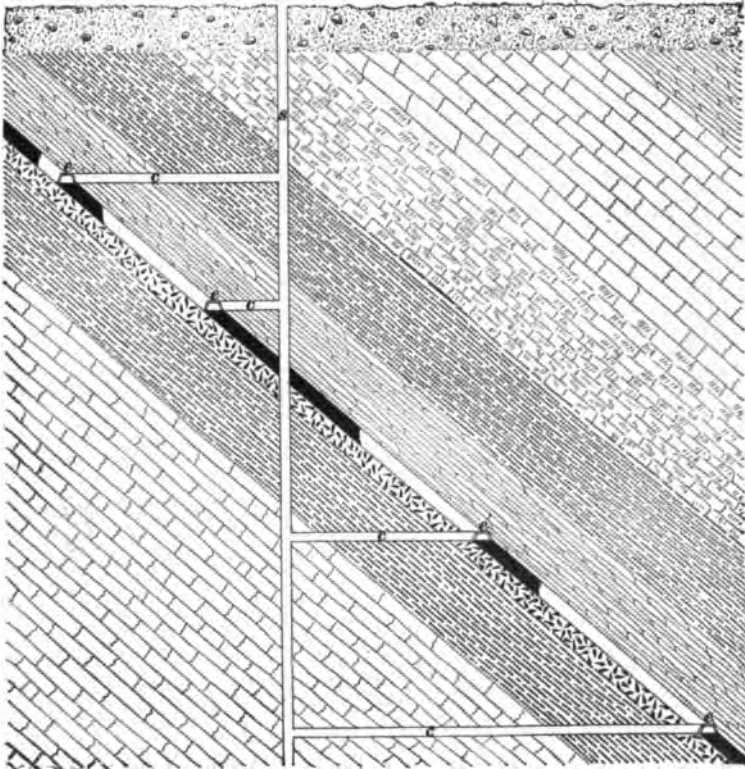

FIG. 577.

regular distances apart. At the points of intersection of these cross-cuts with the seam, levels *c* are driven right and left. These levels follow the strike of the seam, and as the



inclination is very irregular they are very crooked. The coal is then worked to the rise side of these levels, as shown in the figure.

**1770.** Fig. 578 shows a method of mining a moderately inclined seam 21 feet thick, in the district of Grande Combe, in the south of France. The plan *A* is taken by supposing the strata to be removed above the line *s t u v w x y z* shown on section *B* which is taken along the line *a b* of the plan *A*, and drawn by increasing the vertical dimensions.

The primary work is in the lower 7 feet of the seam in

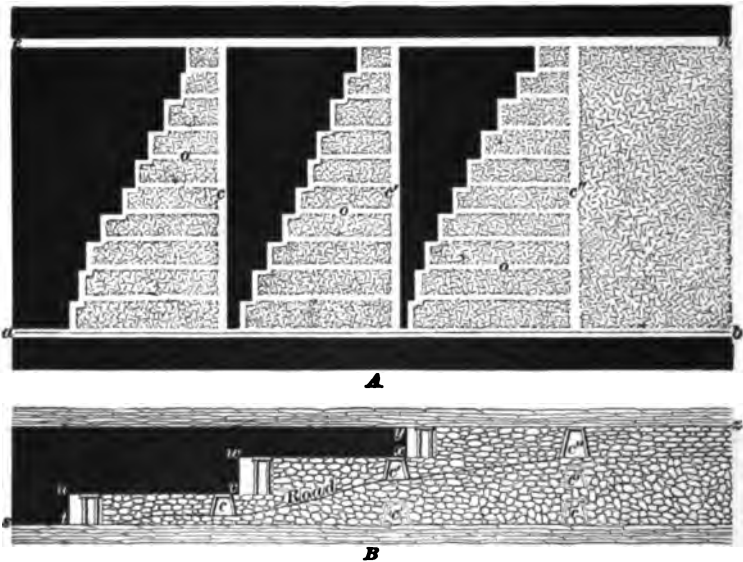

FIG. 578.

which a level *a b* is driven, and from this level inclines *c* from 240 to 300 feet apart are driven to the full rise. Every 30 feet roads *o* are turned off these inclines parallel with the main level. The packs are made of material sent down from the surface into the workings. The car loaded with stone gravitates along the road *c n* to the working places, where it is unloaded and again filled with coal and returned along the heading *a b*.

When the packs consolidate, the floor is heaved up and the

old roads are closed. The roof of the first incline is now cut down and a road *c'* is formed in the next 7 feet of the coal seam above the old workings, and room roads are started in this layer and carried forward above the old gob. In a similar way the road *c''* and a third set of rooms are made in the upper layer, which is also 7 feet thick.

**1771.** The order of removing the layers may be reversed, or thick seams may have the ordinary methods of longwall applied to them. The seam should be taken out in a number of different lifts formed of layers parallel to the stratification, the top being worked first and the roof allowed to subside on the coal. A 12-foot seam may be divided into two or three lifts, an 18-foot seam into three or four lifts, and so on. It is essential that the gob be well packed. It has been found in either case that in a short time the pack or stowage has been sufficiently consolidated to form a fairly good roof, beneath which the workings may be driven with safety, provided the faces are pushed forward rapidly and plenty of timber is used.

**1772.** Fig. 579 shows the methods of working a thick seam by longwall at Balgonie, Fifeshire, Scotland, at a depth of 480 feet. The inclination is irregular, varying from flat to 22°. The débris gives off very large quantities of blackdamp ( $C O_2$ ). The dark-sectioned portion of the cut shows the first workings in the lower part of the coal, and the light portion shows the second workings in the top of the seam, or where the entire seam is worked out. The workings are opened in sections, consisting of the area between two parallel headings *a b* and *c d*.

A section is commenced by driving the heading *a b* in the bottom coal, or first working, to the rise, and from this heading ordinary working places *p* about 36 feet apart are turned off at nearly right angles to the line of dip. The ordinary working roads are about 10 feet wide; and in order to get height in them the miners take down the coal, which is about 3 feet thick and immediately above the stone parting that makes the natural division between the two workings.

Chocks about  $2\frac{1}{2}$  feet square, which consist of the stone just above the first working, and frequently slabs of wood the length of one side of a chock, are put in along the face, the remaining space being fully packed by débris and slack from the coal so that no vacant places will be left. Of course, it is understood that substantial packwalls are built along each side of the roadways.

The holing is made in a thin parting of soft fireclay which is a few inches from the bottom of the coal; but when more débris is required for stowage, the holing is done in

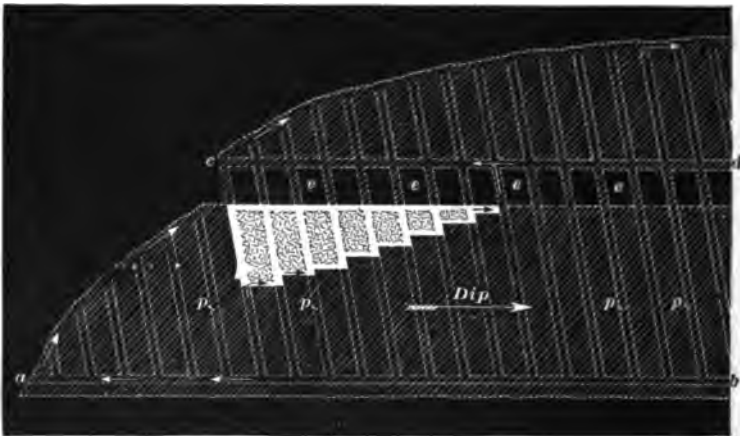

FIG. 572.

the fireclay just below the seam. Where the weight is not too great upon the working face, it is advantageous to make deep minings or undercuts. Props about  $5\frac{1}{2}$  feet long are used to a great extent.

While the workings in the heading  $a b$  are going forwards, another heading  $c d$  is being driven for the next section, and as the ordinary places turned off the heading  $a b$  come on to the heading  $c d$ , they are stopped in the first working, and preparations are made to begin the second workings when convenient. Between the heading  $c d$  and the working faces of  $a b$ , a barrier, or stoop, of coal  $c e$ , etc., about 45 feet thick, is left to protect the heading  $c d$  in the first working. This

barrier is taken out when the second working of the heading *c d* is in operation.

In the second working the inside places are begun first and lead each other backwards about 15 feet, as the figure shows. Each place is therefore 15 feet in advance of its nearest outside neighbor. To build the packs and stow the waste, a following stone a few inches thick, with the débris and slack, is used, and care is taken to leave no space; but if any spaces must be left for want of material to stow, they are usually left in the old roads. Sometimes, instead of coming back with the second working, they are carried forwards.

Owing to side pressure, the roads are about 6 feet wide, instead of 10 feet, as originally made. By pressure from above and heaving of the floor, the bottom of the coal in the second working and the floor of the first working are almost together. The ventilation in the first working is very simple. To ventilate the second working, the current for the section in the first working is split and part diverted round the faces. At times it is difficult to keep the whole current from traversing the faces of the second working; but when this occurs, means are taken to send all the air to the required section of the first working, and a leakage, which is usually sufficient, is allowed for the second working.

**1773.** The advantages claimed for this method in thick seams are:

1. That the whole of the available coal is obtained.
2. That the working faces are easily ventilated.
3. That, as to safety, economy, and efficiency, it compares favorably with any other method of working thick seams.
4. That it gives immunity from gob-fires by spontaneous combustion, which the other methods do not.

---

**LONGWALL RETREATING.**

**1774.** Fig. 580 shows a method of opening up a coal field by longwall retreating in which the greater part of the narrow work is deferred until considerable working face is developed. From the vicinity of the shaft bottom, which is near the center of the coal field, four pairs of headings *a* are

driven at right angles to each other to within 500 or 600 feet from the boundary or crop line, where headings *c* are turned off to the right and left. From these headings other pairs of headings *d* are driven directly to the boundary, where they are connected and the working face formed. The headings *c* are driven until they intersect the boundary or crop line,

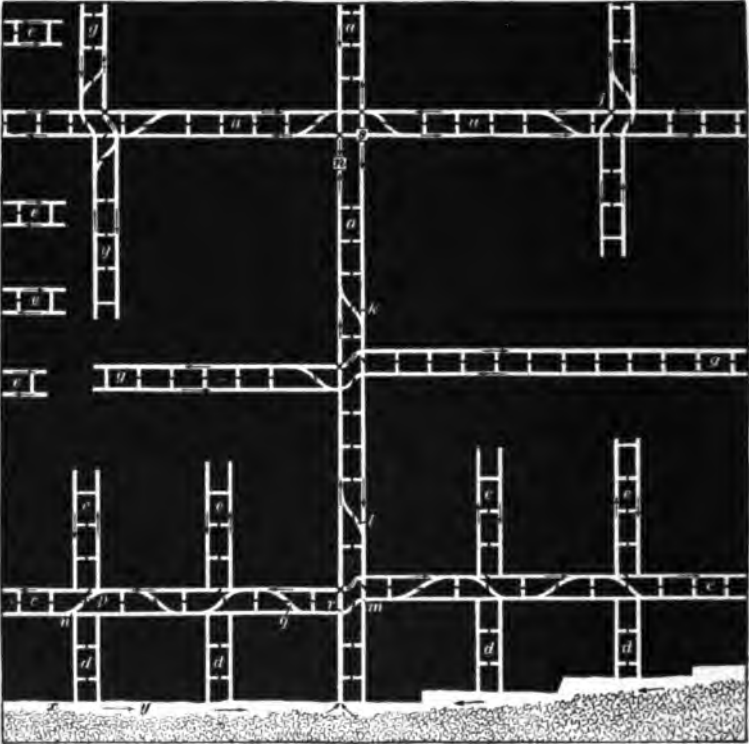

FIG. 590.

or a similar heading coming from one of the other headings *a*. The distance between the headings *d* will depend upon the nature of the coal, top and bottom, and upon the height of the coal.

When the working face is formed and is being drawn back, the headings *e*, which are simply a continuation of the head-

ings  $d$  in a backward direction, are turned off the headings  $c$ , and finally cut off by headings  $g$ . The work is so conducted that when the working face arrives at the headings  $c$  the headings  $e$  will have intersected the headings  $g$  and a condition of affairs similar to that when the working face was first formed will be maintained. This process is continued on all sides until the bottom of the shaft is reached.

**1775.** This method of longwall retreating not only defers the greater portion of the expense of the narrow work until coal is being produced for the market, but also requires a less amount of track than where parallel headings are driven from the bottom of the shaft directly to the boundary line. As the track is lifted in the headings  $d$ , it can be laid in the headings  $e$ , and the only track that may not be reused will be that lifted from the main headings  $a$  as the working face nears the bottom of the shaft.

The downcast shaft  $s$  is at the junction of the main headings  $a$ , where four splits of the air-current are made, and the upcast  $n$  has such a position with reference to the headings that a landing can be formed on either side of it. The principles governing the working of the face in longwall advancing apply here also.

The method of arranging the diagonal cross-cuts should be carefully noticed, for it is highly important in laying out a mine to know how to arrange the haulage roads so that, in any case, it will not be necessary for one driver to wait on the other. Failing to do this is sure to cause great delay and consequently serious reduction in output. Where there are two parallel roads one should be used as the loaded track and the other as the empty track as far as possible.

**1776.** In order to understand the different arrangements of the diagonal cross-cuts, let us suppose that it is necessary to take a trip of cars from the landing near the foot of the upcast or hoisting shaft  $n$  to the point  $x$  at the working face, and return with a loaded trip from the point  $y$ , while other drivers are going and coming from various parts of the mine.

The driver in charge of the trip would first proceed to the cross-cut *k*, to which point there should be a double track from the foot of the shaft, and then if no driver was coming out of the headings *g* to the right, he would pass through the cross-cut *k* and continue along the straight heading, noticing when he came near the diagonal cross-cut *l* that no driver was coming out of the heading *c* to the right, in which case he would still continue along the straight heading and pass through the cross-cut *m*, where he would again observe that no driver was coming out of the headings *c* to the left, before he would pass through the cross-cut *q*, along the straight heading *c*, through the cross-cut *p*, and finally along the heading *d* to the point *x*. After placing his empty trip, the driver would lead his horse or mule to the point *y*, where he would hitch on the loaded trip and pass out the same heading *d* as he came in until he reached the point *n*, where he would turn and pass along the straight heading directly to the point *r*, where he would again turn and go straight to the landing with his loaded trip. It should be observed that the driver with the empty trip must be on the lookout for drivers coming out with loaded trips, and that the driver coming out has no charge upon him or stops to make.

When, from circumstances before mentioned, it is necessary to drive the pairs of headings *d* close together, only one heading of each pair need have a track in it, because one or more headings are usually assigned to a driver, and there is no danger of one driver running into the other. Under such conditions the arrangement of the cross-cuts, as shown in the headings *c*, is efficient; if, however, the conditions of the mine are such that the pairs of headings *d* can be driven a considerable distance apart, say 100 or 200 yards, then each heading of the different pairs will be provided with a track on which the loads and empties pass over. With this situation of affairs, the cross-cut *p* should connect with the first heading of the extreme left-hand pair *d* rather than with the second of that pair, as shown in the figure, in order to facilitate the haulage from both headings. Similar arrangements should be made at all junctions of the pairs

of headings  $d$  and  $c$ . One of the pairs of headings branching from the junction  $j$  will intersect the headings  $g$ , and, consequently, needs no cross-cut. There is no track laid in the diagonal cross-cuts leading to an overcast nor in the heading beyond until another diagonal cross-cut is met. The above system of laying out the headings requires no backswitching.

1777. At several Warwickshire collieries in England four contiguous seams are worked at a time. Fig. 581 shows a plan  $A$  taken by supposing the strata above the line  $wvu$  to be removed, and section  $B$  taken along the line  $xy$  of a set of rooms turned off levels in the dip and worked back to the shaft on the forewinning method—longwall retreat-ing. The dotted lines crossing the strata, as shown in section  $B$ , show the position of the horizontal tunnel  $oa$ , connecting the working faces of the four seams at the foot of the slope  $ab$ .

When the rise workings of the pit have been worked out, the main dip incline  $ab$  of each district is, whenever possible, driven to the boundary of the area to be mined by the shaft. The general way of opening out a district to the dip is as follows:

A pair of roads  $ab, cd$  are driven in the lowest of the seams to be worked, if possible to the boundary, but in all cases a distance of not less than 1,500 or 1,800 feet. A cross-drift  $ao$  is then driven through all the four seams, and they are each opened out by level headings  $e$  to a distance of from 450 to 600 feet on each side, and cross-drifts  $n$  are again driven at each end and generally one in the middle connecting the four seams for ventilation. In this way eight different walls, stalls, rooms, or working places are at once made.

1778. It will be observed that, by working on this system, with such a very thin parting between the seams, there must necessarily be considerable breakage. The faces can not possibly advance at a greater rate than say 1 foot per day, and the distance at which the face of one seam lies



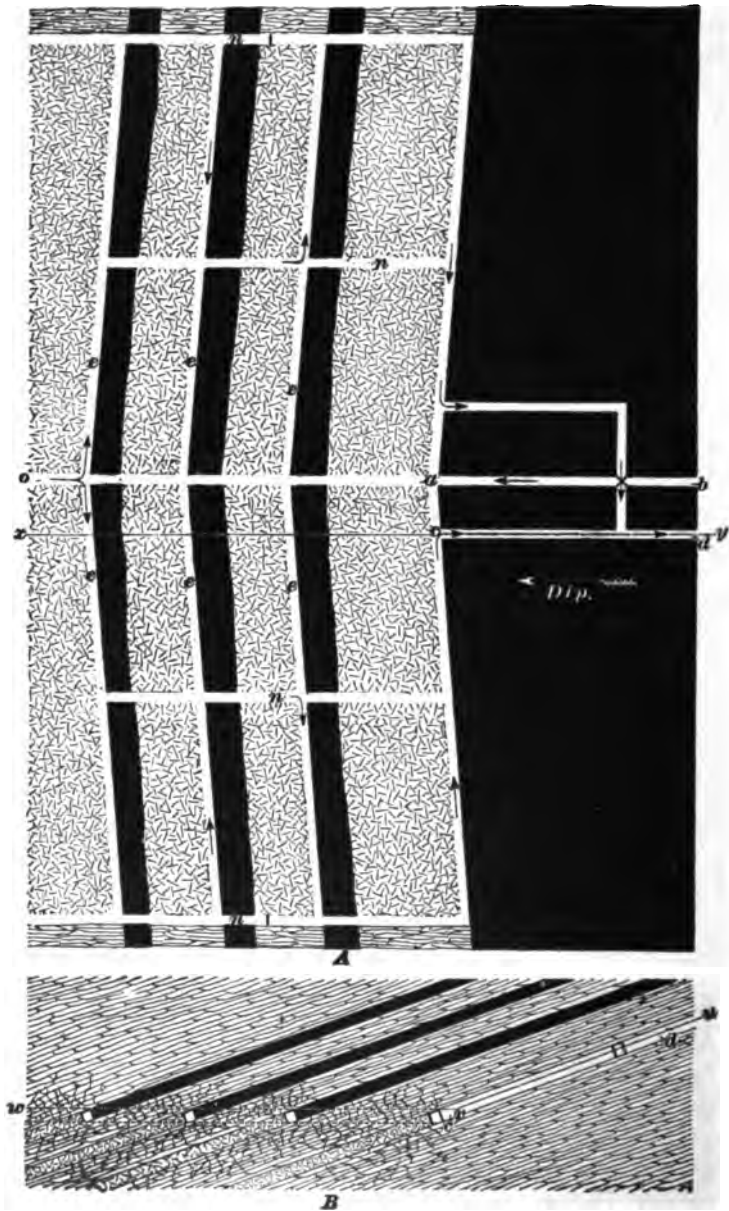

FIG. 861.

behind another is only about 30 feet, so that in each case the seam has five or six weeks to settle down. This causes a large percentage of fine coal, and a consequent deterioration in its value before being worked. The ventilation for this method is extremely simple. Descending one incline, the air crosses along the faces, as shown by the arrows, until, finally, the two currents join at the air crossing and proceed up the return. On account of the continuously moving working face, it is necessary to keep the overcast in the slope *a b* some distance ahead in the solid coal.

**1779.** The main flat *ao* is made to last two or three months, and close to the roadside the faces are allowed to lag slightly behind. It is moved forwards about 60 feet at a time, and while it is being moved forwards the faces close to the roadside are worked up quickly. Every effort is made to let the top settle gently and without breaking by building packs, which are generally about six feet wide and having from 12 to 15 feet of intervening gob between them, so as to save the seam above as much as possible. The material for these packs is obtained from the holing dirt or from that obtained by repairing the main flat. Notwithstanding all precautions, the upper seams are sure to be more or less crushed. Where permanent stoppings or frame doors can not be put in, canvas doors are used.

---

#### LONGWALL METHODS COMBINED.

**1780.** Fig. 582 shows a plan of working a mine by combining longwall advancing and longwall retreating. The upper portion is an ideal plan of Scotch longwall, in which the face is carried forwards in a semicircular form and the roads are turned off each other at angles of  $45^\circ$ , which arrangement, in general, gives best results.

There are numerous roads not more than 8 yards apart leading to the face. Many of these roads, however, are soon cut off by the principal or diagonal roads, and dispensed with; and frequently a number of the diagonal roads are cut off by a cross-cut, which diminishes greatly

the number of permanent haulways to be maintained. It

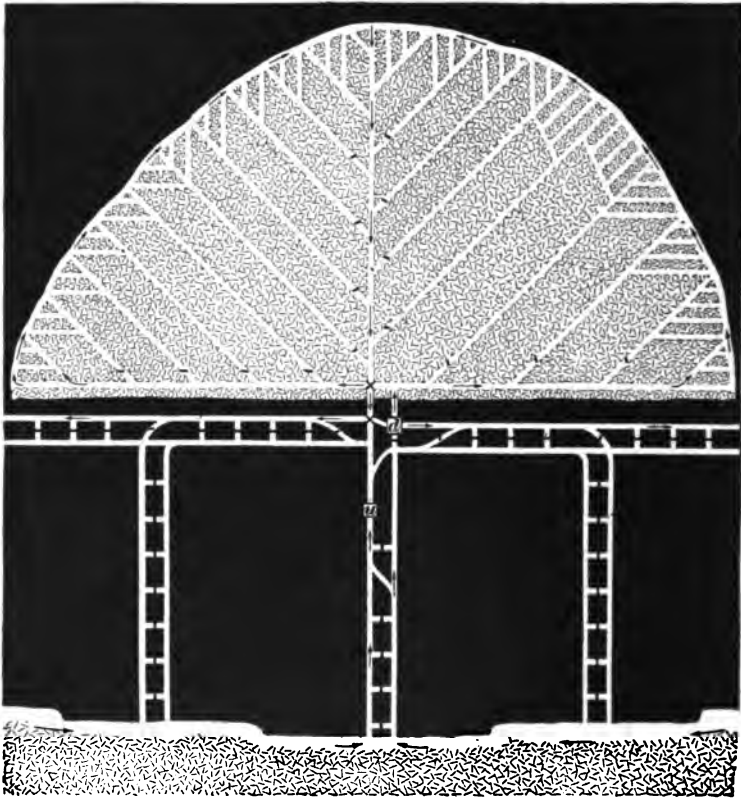

FIG. 582.

is understood that packwalls and chocks are built along the roads, as described through this subject.

**1781.** This plan of working is suitable for seams up to 3 feet thick, having a weak top, a pitch not greater than  $20^{\circ}$ , and situated at almost any depth. It is largely the method from which most of the longwall practised in the western United States has been copied.

**1782.** The lower portion, where the coal is from 4 to  $4\frac{1}{2}$  feet thick, is worked on the retreating plan. Narrow head-

ings are driven in pairs to the boundary, and the working face is drawn back towards the shaft. These pair of headings are usually from 200 to 300 feet apart, depending, as stated before, upon the nature of the coal, top and bottom; and the car is taken along the face. A glance at the figure will show the advantages of longwall retreating over longwall advancing; for, in the former, it is obvious that the haulways which are made in the solid coal will not be such a source of trouble as those in the latter, which are made through the gob and maintained by packwalls along each side; also, the course for the air is less broken, even along the working face, for the gob is not cut up by roads formed in it, as is the case in longwall advancing. This system is indisputably the best for good and efficient ventilation and haulage, particularly mechanical haulage; and perhaps the only objection to it is that it will not yield returns as soon as the advancing system; though, in the end, it is the most satisfactory and profitable.

**1783.** Such a combination of systems enables the operator to get an unvarying supply of coal, for, while the working force on one side is continually leaving the shaft, the one on the other side is approaching it. The location of the downcast with reference to the workings is a matter of choice, but in virgin coal fields the upcast *u* and the downcast *d* must necessarily be within a reasonable distance of each other, in order to secure, as early as possible, a permanent return airway. The coal in this plan is mostly caged on that side of the shaft next the longwall advancing, and one of each pair of headings is used for the loaded, and the other for the empty cars, as the arrangement of the diagonal cross-cuts will suggest after having studied Fig. 580.

**1784.** It should be borne in mind that the principal points to be considered in longwall working are :

1. The direction in which the working face should advance with reference to the cleavage planes of the coal, and to the dip of the strata; for upon the determination of the

proper direction will depend the best manner of supporting the roof and of getting the greatest amount of lump coal.

2. Whether the working face should be kept in a continuous line or stepped; for this also affects the maintenance of the roof and the size of the coal obtained.

3. The rate of advance of the working face. Sometimes it is advantageous to allow the web of coal to remain unsupported upon the sprags or cockers until the pressure of the roof acts upon it; while, on the other hand, it is sometimes best to advance the working face as fast as possible.

4. The proper building of the packwalls and the stowage of the gob. The packwalls should be built as strong as possible, carried close up to the roof, and kept well up to the face; where there is sufficient available material it is always best to stow the gob completely.

**1785.** In conclusion it is scarcely necessary to say that the system is applied to seams varying much in thickness, depth, and in the nature of their roof and floor. With a straight or uniformly curved face and the bearing in properly done, it is undoubtedly the best system to obtain the greatest percentage of lump coal and to get the largest proportion of the entire seam at a minimum cost; but where roadways must be made close together and the roof and floor are hard, requiring the use of explosives, it is doubtful if the system has any advantage over the pillar and chamber method.

The use of longwall methods in the United States is becoming more general; and the fact that it is now being recognized that our supply of coal is limited, *exhaustive mining* is becoming of *great* importance in determining mining methods.

**1786.** It is claimed that longwall, particularly longwall retreating, could be applied to many of the low and moderately inclined anthracite seams with almost inestimable advantages over the present system; indeed, theory strongly upholds that such would be the case, and a great deal of experience on the Eastern Continent corroborates the theory.

The principal difficulty of introducing longwall in the anthracite region for some seams seems to be that no operator desires to take the risk of giving the system a fair trial in the hands of experienced men, so long as he can profitably operate upon the established plan.

**1787.** Longwall advancing has been tried on a small scale in some parts of the anthracite region without success. Longwall retreating, which seems to be the most likely method of working many anthracite seams on a more economic and exhaustive plan than is now in use, has not yet been tried. It not only requires a radical change in the mine cars, but also requires that the operator wait until nearly all narrow work is driven before he can get any returns, something very much in opposition to the principles (perhaps conditions) of the American operator.

---

#### CREEP IN LONGWALL.

**1788.** Creep in longwall is simply a swelling up of the bottom in the roads, caused by the weight resting heavily on the roadside packs. Where there is a soft fireclay (hard fireclay may be made soft by moisture) floor, and the gob is not very fully stowed, the packs will receive a great amount of pressure, and the soft fireclay naturally swells up in the spaces on each side of the packs, and as the heaving up meets with practically no resistance in the roadways, they may become closed up entirely. There are few cases of longwall where creep does not take place to some extent, although, where the gob is stowed completely, the weight of the overlying strata is distributed almost entirely over the bottom, and the conditions for creep—the concentration of the superincumbent pressure upon a small area of the bottom—are entirely avoided.

**1789.** Fig. 583 shows a longitudinal section *A* and a cross-section *B* through a road in longwall workings in which a creep has occurred. The cross-section *B* is taken through the line *a b*, and the longitudinal section through the line *f e*. It will be observed that the packwalls *p* on

either side of the road  $r$  are forced into the bottom by the enormous weight of the roof, and a consequent upheaval

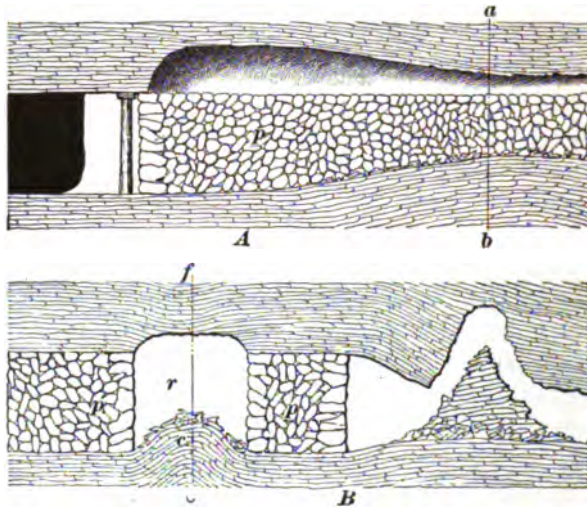

FIG. 568.

of the bottom, or creep  $c$ , on both sides of the packs is produced.

The degree of creep is greater in the road than on the far sides of the packwalls, because it is due to the combined effect of both packwalls. The shaded portion of the roof in the longitudinal section  $A$  shows the amount of roof that has been taken down in the road to secure height, also the way in which the creep has affected the roof.

**1790.** It is a very difficult matter, if not impossible, to stop a creep when it gets a start. Therefore, it is imperative to guard against accident by building the packwalls, in the first place, sufficiently wide and strong to be on the safe side.

#### TESTING THE ROOF.

**1791.** It is one of the important duties of a mine official to see that the roof in hauling roads, traveling roads, and even in working places is in a safe condition.

The safety of the roof is judged by general appearances and the sound produced on tapping it with a small hammer

or other tool. If it looks solid and the sound indicates that it is so, the roof is usually safe; but this alone should not be implicitly relied on. The lamp should be held up to the roof, and a careful scrutiny be made for joints, or cracks.

The sound may sometimes indicate that a stone is solid when it is not. This deceptive indication is generally due to the large size of the stone. Bell-shaped, wedge-shaped, and other loose pieces in an otherwise solid rock roof also emit a solid sound when struck with a pick or hammer. If a hollow sound is emitted when the roof is struck, the stone is unsafe and should be taken down, or timber set up under it. The sides must also be examined; this is usually done by carefully examining them with the aid of the lamp.

---

#### DRAWING - TIMBER.

**1792.** The principal object in drawing the *back timbers* and breaking up small coal pillars (if any be left in) is to enable the roof to settle regularly and to release the weight at the face. This weight would otherwise become excessive and reduce the percentage of lump coal. It would also increase the amount of slack, and would cause the weight to crawl over the pillars and destroy them.

Accidents have occurred from the back timbers having been left in too long. Although timber-drawing is dangerous, if the timber is left in, the danger increases considerably irrespective of the waste of timber which it entails.

**1793.** The timbers should be removed as quickly as possible after the work is started, always allowing a sufficient number of props at the face where miners are working.

The removed props can generally be used several times. Even when the removed timber is broken, it can be used for cap pieces or in building chocks or nogs.

Great judgment and experience are required to ensure that the best order of drawing props will be adopted, especially where there is a considerable area of waste. It may be best to leave a few props behind to assist in recovering the others with a little more safety. Where the top is too



dangerous, the props must not be drawn if there is danger to the workmen in so doing. Removing one prop sometimes starts the roof, which falls, bringing a number of posts with it. The props in the rear row should be drawn first. Not more than one prop should be drawn at a time, and there should be perfect silence while this is being done. There should never be less than two or three men present who take part in this work.

**1794.** Timber is drawn in several ways. The tools and appliances used for this purpose are shown in Fig. 584. The

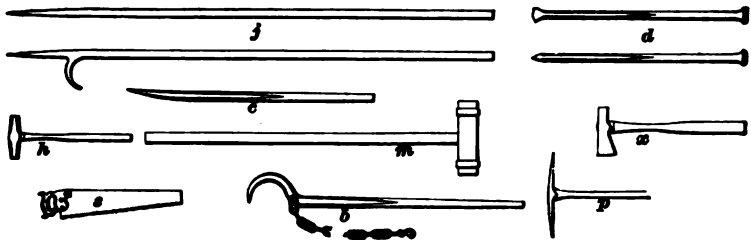

FIG. 584.

first thing to be done in drawing a prop is to loosen it at the top or bottom, depending upon which point is the most accessible and the ease and convenience with which the work can be accomplished, by means of a pick *p*, crowbar *c*, or drill

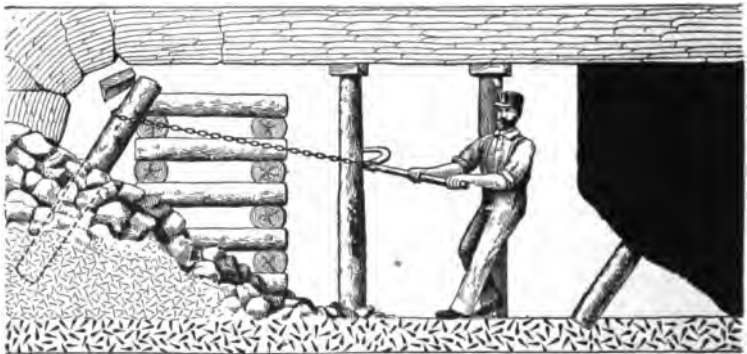

FIG. 585.

*d*. With a pretty safe roof, the prop is knocked out with a hammer *h* after all loose pieces have been carefully removed.

Where the top can not be depended upon, the workman jumps back immediately after the blow is delivered on the head of the prop. The blows are repeated until the prop falls, but between each blow the workman waits and listens for a sign of the roof giving way. When the prop falls, one of the workmen promptly sticks his pick *p* or jobber *j* into it and drags it out, in this way avoiding that portion of the roof from which the support has just been removed. In many cases the prop, after having been loosened with a pick, is loosened still further by hammering, after which a dog and chain *b* is applied from another prop, at a safe distance, and the prop levered out with safety (see Fig. 585).

**1795.** When the foot of the prop is inaccessible or the post is heavily weighted, it is cut with a sharp ax. This is a dangerous practice, especially in thick seams, and quite unnecessary, because the work of "throwing" the props can be done safely and in a thorough manner by boring a shallow hole in the prop with an auger and inserting therein 1 inch of a stick of dynamite, by which the prop is broken up.

In cases where only the head of the prop is accessible, a dog and chain is applied to it in such a way as to draw it up. The chain is thrown around the prop, and forms a noose into which the end of the dog is inserted. The dog rests on a post placed horizontally near the one which it is intended to draw. The grip of the chain tightens as the force is applied to lift the prop.

**1796.** An additional help in use at some collieries is

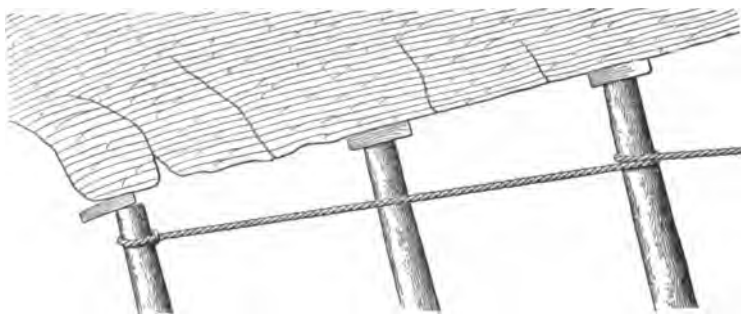

FIG. 586.

shown in Fig. 586. It consists of a rope 7 yards long, with

a hook to it. The end with the hook is lashed round the prop which is to be drawn, and the other end is securely fastened to a firmly set prop at some distance to the rise. After the prop has been sufficiently loosened, or while it is being hammered, or while the dog and chain are being applied, a sudden jerk produced by one or two men throwing their weight upon the tightened rope near its middle point will greatly help to loosen the prop and enable the men to drag it out immediately and with safety.

**1797.** Timber drawing in connection with falling and cutting down top coal requires more care than ordinary timber drawing, inasmuch as the object is not only to draw the props, but also to get out as much coal as possible.

**1798.** When the back timber is drawn and the roof allowed to settle in the waste, or gob, it acts as a lever, the fulcrum of which lies over the end of the mining or holing, and exerts a slight pressure on the face of the coal. But in many cases, if the back timber is not drawn, excessive weight is thrown forward on the faces, and, instead of assisting in the next mining, the result is that the coal is made tougher, and, consequently, the operation of holing or mining more difficult to perform. In many cases, however, this excessive pressure causes the roof to break off at the face, destroying entirely the beneficial effects of the leverage for the next mining.

# ELECTRIC HOISTING AND HAULAGE.

---

## POWER TRANSMISSION AT MINES.

---

### GENERAL CONSIDERATION.

1. In the operation of a mine, one of the most important considerations is the choice of the method of distributing power to operate the various apparatus employed. Whether this power can be transmitted to the best advantage by means of electricity, steam, compressed air, or water power, will depend largely on local conditions.

In a general way, it may be said that the advantages of electricity increase with the distance and the number of points to which power is to be delivered.

With both steam and compressed air the cost of installation and the loss of power (as well as the danger of breakdown) increases rapidly as the system is extended. These systems are also affected in efficiency by changes of temperature, which have no appreciable effect on electrical distribution. Moreover, by reason of their flexibility, electrical conductors are not so generally liable to injury and breakage by floods or shifting ground as are the rigid pipes conveying steam or compressed air.

Up to within a few years, a serious drawback to the use of electricity was the limited application of motors to the different forms of mining machinery, and also the lack of reliability in their operation. Recent advances, however, have been so great that this form of power is rapidly coming

to the foreground for mine haulage, hoisting, pumping, lighting, surface traction, and the operation of machine shops.

**2. Long-Distance Transmission.**—Electricity may be said to excel other methods where water power is available within a reasonable distance, say up to 40 or 50 miles (depending on the relative cost of fuel), when the local conditions require the use of power at scattered points, or where the mine is off the line of railroad and the haulage of fuel involves heavy expense. In this latter case, the placing of an electric generating station at some central point and the transmission of current to the various places where power is used, both on the surface and underground, will generally effect considerable saving.

**3. Relative Advantages of Electricity and Steam or Compressed Air.**—Where the bulk of power is used for drilling and pumping near the boiler plant, steam and compressed air have an advantage, as the reciprocating motion of the steam and compressed-air cylinder is more advantageous in these operations than the rotary motion of the electric motor. On the other hand, a more extended use of hoisting, hauling, and ventilating machinery will generally favor the use of electricity, especially in view of the added advantage of its use for lighting and the greater flexibility of the installation.

**4. Haulage.**—With long hauls and small tonnage, wagon haulage is undoubtedly the most economical where roads of reasonable quality and grade are available. As the distance shortens or the tonnage increases, the use of a track becomes advisable, and ultimately on this track the locomotive or cable replaces the mule or horse in economy. Again, the limitation in the use of locomotives to grades not exceeding 4% to 5% where they are long or continuous will often decide in favor of the hoisting drum and cable or the overhead cable with buckets. Then, again, for short distances and large tonnage, the use of conveyer belt or bucket must receive consideration.

In connection with the use of tramways, it is interesting to know that whereas the pulling power (or direct pull) required to haul 1 ton on rails at the rate of 3 miles per hour ranges from 4 to 12 pounds, the power required for macadam road is from 45 to 65, and for an ordinary dirt road it is over 200 pounds.

In any case the form of power to be used will depend largely upon the question which form can be used to the most advantage for the largest number of purposes. Each system has its advocates, and caution should be observed in accepting the data and comparisons used in trade catalogues by manufacturers anxious to sell their own wares.

---

## ELECTRICAL TRANSMISSION.

5. In the event of the selection of electricity, the choice of the system must be determined—whether direct (continuous), simple, alternating, or polyphase current machines shall be used, or possibly a combination of two of these systems. The voltage of the direct-current machine is limited in practice to about 600 volts, due to complications in insulation and to increasing the number of segments of the commutator for higher voltages.

For these reasons, direct-current generating apparatus can not be used to advantage when the power is to be transmitted for long distances. Roughly speaking, a wire of a certain cross-section will carry a given number of amperes of current without undue heating. As the *power* or watts carried is the product of the amperes multiplied by the volts, twice as much power can be transmitted over the same wire by doubling the voltage, and so on in the same ratio.

This law is to be compared to the capacity of piping, carrying water under varying pressures, except that with water the friction increases with the speed of flow. As a general statement, it may be said that in the electrical transmission of power a loss of over 10%, at most 15, in the line is not permissible, even where the source of power is water.

A more detailed explanation of this statement will not be amiss. Taking, for example, a case where an abundant water power is available: at first sight it would seem that as the prime energy is secured at a nominal cost, the loss of even 25% and over, caused by the use of small wires in transmission, would be more than offset by the saving in cost of copper. This expense for conductors for distances of over 25 miles may amount to more than one-half the total cost of installation. Several causes combine to effect this; among them are:

1. It is difficult to regulate the voltage at the point of using the electric current when there are constant variations of load, as the potential will decrease rapidly as the load increases, and *vice versa*. This fluctuation changes the speed of motors and the brilliancy of lights. (There would, of course, be little drop under no load.)

2. The interest on the increased cost of installing the larger water-wheels or turbines, dynamos, and fittings largely offsets the expense of larger conductors.

---

#### CHOICE OF SYSTEM.

6. For the transmission of energy for short distances (not exceeding say 2 miles) where it is to be used chiefly for power and incidentally for lighting, the choice will rest between

- (a) The direct current, not exceeding 600 volts for surface, 500 volts for underground, and

- (b) The multiphase-alternating current with either induction or synchronous motors, with the addition, where electric locomotives are to be used, of rotary transformers to supply direct current to them.

7. For the transmission of energy for lighting, with incidental use for power, the monocyclic system or two-phase three-wire system is preferable. With the monocyclic system the lighting current is conducted by two wires, a

third wire brought from an intermediate point in the wiring of the dynamo being added for power use.

8. Long-distance transmission requires some form of alternating current, as the cost of conductors for the low-potential direct current would be prohibitive.

With the use of electricity, the greatest freedom is permitted in selecting a site for the power plant. Instead of being arbitrarily located at or in the immediate vicinity of the mine shaft or mill, it may be placed with due reference to the cheap delivery of fuel, and also due regard to a satisfactory supply of water for the boiler and condensing engine.

Moreover, where power is used at several scattered shafts or works, one generating plant only will be necessary, in which efficient, large unit boilers and engines can be installed.

---

#### PRACTICAL EXAMPLES.

9. **Metropolitan Railway Company of New York City.**—This plant furnishes a good example of the economy effected by the centralization of plant, and may be described as follows:

The power station supplies current for the widely scattered electric-car lines of the Metropolitan system, and is located between Ninety-fifth and Ninety-sixth Streets, First Avenue and the East River. Although this location can not be called a central point of distribution, the greater facility with which coal and ashes can be handled and the unlimited supply of water from the river for condensing purposes, in addition to the much lower cost of land, governed the selection.

10. The building is a steel-frame structure with brick walls. The ground plan is 200' × 280'. The boiler room will contain 87 Babcock & Wilcox water-tube boilers in three tiers, each boiler having a rated capacity of 250 H. P., capable of being forced to 400. An engine room of about 100' × 200'



will contain 11 vertical cross-compound condensing Allis engines of 4,500 indicated H. P. each at their maximum efficiency, but capable of running continuously at 6,000 H. P., and for a short time at 7,000. To these engines will be coupled 3,500-kilowatt generators of the General Electric Company (approximately 4,700 H. P.). The generators will run at 75 revolutions per minute.

The entire floor above the boilers will be occupied by the steel coal-bins, with a capacity of 9,000 tons. The chimney is the largest in the world, being 353 feet high, with a 22-foot core. As the ground was very poor for the foundation, over 1,200 piles were driven, and these were topped with a solid block of concrete 85 feet square and 20 feet deep. The chimney built upon this block contains over 3,500,000 bricks.

11. At Fiftieth Street and Sixth Avenue, nearly  $2\frac{1}{2}$  miles away, a substation with a capacity of over 6,500 H. P. will convert the high-pressure three-phase current (6,000 volts) to the necessary 550 volts direct current for use on the conduit-trolley line, by means of rotary transformers. At One Hundred and Forty-sixth Street, also about  $2\frac{1}{2}$  miles away, another substation will be located with a capacity of 5,300 H. P. Three and one-half miles away, in Twenty-fifth Street, there will be one of 6,300 H. P., and at Houston Street, 5 miles away, one of the same capacity. The farthest, located at the lower extreme of the city, 7 miles away, will be of 4,000 H. P. Two additional stations will probably be located in the lower end of the city at a later date.

This plant with its 45,000 H. P. capacity forms one of the most interesting examples of the extensive transmission of electric power where the current is used almost exclusively for street-railway work and where all wires have to be placed underground. The main cables are insulated with rubber and woven braid and covered on the outside with heavy lead tubing. This is then drawn through vitrified brick conduits adjoining in most cases the tracks of the company.

**12. Southern California Power Company's Plant.**—Ordinarily a distance of 50 miles is the practical limit of electrical-power transmission, but in localities where fuel is expensive and large amounts of power are required, a much greater distance is practicable, especially where water power may be obtained. This case is well illustrated by the plant under consideration, which may be described as follows:

**13.** In the mountains 83 miles from Los Angeles, water power under a head of 700 feet is used to drive (Pelton) water-wheels coupled direct to three-phase generators of 750 volts pressure. This current is transformed in three sets of static transformers to 1,900 volts, giving a working pressure on the line of 3,300 volts. Four 1,000 H. P. dynamos are now operated and six additional machines of the same size are being installed. The current is used at Los Angeles for lighting, street-railway, and other power purposes. For the trolley service, the necessary direct current is secured by means of rotary transformers. In mines favorably located below the source of water power, water-wheels and hydraulic motors can be utilized direct for hoisting and pumping; but for one such case there are a score where the water is located below the point where it is required, with hills intervening, or too far away to be piped.

---

**TRANSMISSION LINE.**

**14.** Having determined the location of the power plant and the electric system to be employed, the next consideration is the construction of the transmitting line.

(For methods of installing dynamos and wiring switch-board and station connections, see *Dynamos and Motors*.)

**15. Line Construction.**—Whether a high or low tension system is used, it is advisable to construct the pole line in the most substantial manner. Twenty-five to thirty-five foot poles of not less than 5 inches in diameter at the top should be used. These should be set at least 4 feet in the ground,

preferably 5. The pole hole should be dug large enough to permit the butt of the pole being dropped straight in without forcing and should be filled in slowly with dirt, tamped with iron rods to insure thorough packing of the earth. Poles used at corners or angles should be preferably of 7 inches top diameter when heavy wires are carried, and sufficiently long to permit of their being set 5 feet 6 inches in the ground. Where the ground is moist, it is well to smear the butt end of poles with pitch or tar and have this extend at least 2 feet above the ground line. The proper distance between poles will depend on the character of the ground and the weight and physical strength of the wire. One hundred feet interval is perhaps the best for general conditions, and a distance of 125 feet should never be exceeded, except with the use of aluminum conductors. This metal is only about half the weight of copper for equal conductivity and equal breaking strain, so that a much longer span is permissible. For every 5 feet added to the length of the pole, it should be set an additional 6 inches in the ground.

**16. Insulation.**—There are two methods of insulating conductors carrying electricity at high pressure—continuous insulation and interval insulation. In the former, the wire or cable is covered or coated throughout its length with rubber or other insulating material. In the latter, bare wire is supported at intervals on glass, porcelain, or composition insulators. In the aerial transmission of very high pressure currents, complete reliance must be placed on the quality of pole insulators and on the mechanical strength of the wire and line construction.

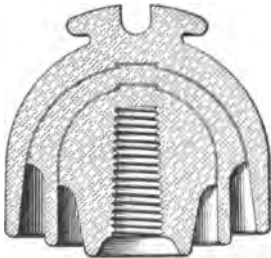

FIG. 1.

Figs. 1 and 2 show double-petted porcelain insulators, such as are used in high-tension work. The shaded lines show that it is made in sections and melted together by the vitrifying furnace. Where high-tension wires

cross telephone or telegraph lines, it is best to place the high-tension wires above, or if below, to protect them by guard wires to prevent the grounding of the system in the event of the breaking of the lighter wires.

**17. Lightning - Arresters. —** In high altitudes and exposed country, the line should be protected by occasional lightning-arresters. Several different forms are effective. They are connected to the line at the terminals and at exposed points. One side is connected to the line by heavy wire or cable, the other to the earth, and it is essential that the latter section should be carried to moist ground in order to be effective. One type consists of series of cylinders of so-called non-arcing metal, placed parallel and close to each other, with little gaps between, which the lightning will jump across, but which could not be spanned by the relatively low tension of the service current.

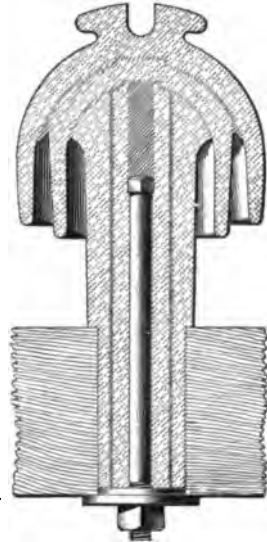

FIG. 2.

The term non-arcing metal is used for the reason that the gases formed by the burning metal due to the passage of the lightning discharge do not form a conducting path for the current of the line, as is the case with the majority of the metals. In another type the lightning jumps a small air-gap between two horns spreading out from each other, and there is placed a strong magnet whose lines of magnetic force pass across this gap with the effect of counteracting the arc, or, as it is expressed, "blowing it out." A third form consists of two large disks of metal placed with a small interval between them and with a sufficient surface to radiate the heat so rapidly that the arc or center of heat is dissipated.

**18. Interior and Underground Wiring.** — The electric current may be carried at high potential to the entrance of a building or mine and with carefully insulated cables at pressures up to 1,000 volts to central distributing points in mine or building, there to be converted to a pressure not to exceed 500 volts. This voltage is not sufficiently high to seriously injure any healthy person who may accidentally handle the bare conductors or connections of a machine. The method of running the wire cables down a shaft will depend on the available space, or whether it is "wet," and on the voltage of the current.

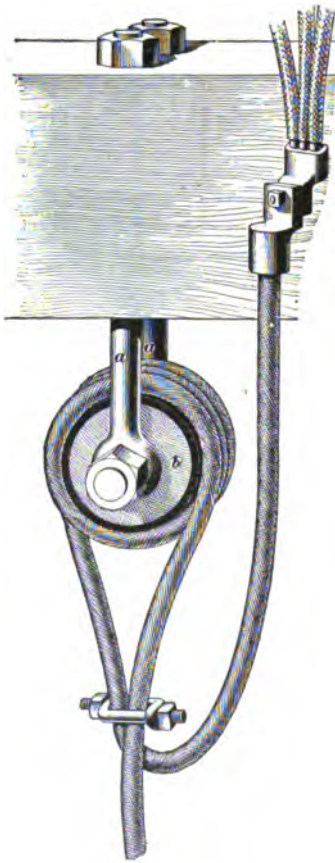

FIG. 3.

**19.** An ingenious device is shown in Fig. 3, by means of which cables may be suspended in vertical shafts. This device consists of a pulley with heavy bolts for attaching to the beam at the head of the shaft and projecting downwards. The large hardwood rollers are soaked in paraffin or paint and covered with soft rubber. The ends of the cable are carried around these pulleys two or three times, and then down the shaft, where they should be firmly attached to the side of the shaft on insulators at frequent intervals. The upper ends are connected to the outside feeders by heavy brass couplings which permit of being disconnected at will.

**20.** Where the current is to be used for underground locomotive traction, bare wire must be used along the haulageways. This wire is attached to the roof of the tunnel or gallery, between or over one of the rails, according to the character of the roof or the location of the trolley-pole on the electric locomotive. The trolley supports may be placed at from 25 to 40 feet apart.

**21. Hangers.**—Where the entry is timbered overhead, the hangers and insulators supporting the trolley-wires can be attached to these, otherwise special supports will be necessary. They must be strong enough to hold the weight of the wire and to withstand the constant jar and vibration to which it is subjected. Where the roof is good and its height uniform, the supports can be attached directly to it.

Fig. 4 shows a good form of hanger and insulator. The insulating substance *a* is protected from injury by accidental blows by a metal hood-shaped covering *b*. The insulating material in the center has steel studs insulated from each other, projecting upwards and downwards. The upper one is fastened to the iron hood which has



FIG. 4.

arms *c* for attaching to the roof. To the lower stud *e* is fastened the clamp *d* for holding the trolley-wire. This clamp consists of two jaws of bronze, hinged to an interlocking pin which passes through the head of the stud-bolt. The clamping effect is secured by screwing the cone-shaped nut down on the stud-bolt; this spreads the upper part of the jaws apart and tightens the grip on the wire. The clamp *d* can be loosened at any time for readjustment by turning the nut *e*.

**22.** Fig. 5 shows a trolley hanger and the method of suspending it from the roof. A hole is drilled in the top rock, and a bolt with its upper end made wedge shape and larger

than the diameter of its stem is placed in the hole. A short piece of gas-pipe which is split at its upper end is also placed in the hole and over the bolt. A hole is then bored in a piece of 4" × 3" timber, just large enough to admit the bolt

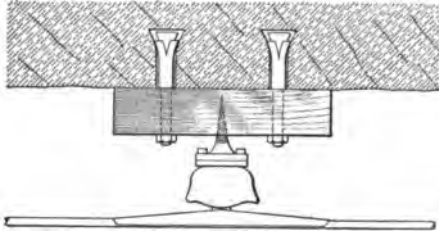

FIG. 5.

and prevent the gas-pipe from entering it when the piece of timber is put over the bolt and up against the roof, and the nut on the end of the bolt is tightened up. It can be seen that as this nut is screwed up the widened portion of the bolt is wedged tightly into the gas-pipe, which is in turn forced against the side of the hole. The block of wood is supported in this manner at two points, and the insulated hanger is screwed into it. This device serves very well where the roof is approximately the proper height for the trolley-wire, but where the roof is high, it is a good plan to drill two holes about 2 inches in diameter and 10 inches deep, and about 12 inches apart, crosswise over one of the rails. Wooden plugs are then driven into the holes and sawed off the proper height above the rails, and a piece of 1½" × 4" × 14" timber nailed on to the ends of the plugs by using three twentypenny spikes in each.

Malleable-iron pins are also made in two halves, one having projections, the other smooth. The half with projections is first placed in the drilled hole in the roof and the other or smooth half is then driven up beside it. This form is very satisfactory with a good roof.

**23. Frogs.**—Fig. 6 shows a frog used at junction points. It is similar to those used in street-railway practice. Being placed just forwards of the switch in the track, the trolley arm before reaching it has received an inclination in the direction the locomotive is taking and automatically shifts to the correct overhead wire.

**24. Return Circuit.**—In mine traction as in surface traction, the rails, properly bonded, are generally used for the return circuit. That is so say, the current passes from the bare trolley-wire, through the trolley arm to the starting resistance and motor, and through the frame of the motor and wheels to the rails, and so back to the generator. The conductivity of iron being low and the fish-plates connecting the different lengths of rails being liable to rust (which



FIG. 6.

largely destroys its conductivity), the path for the return current is assisted by "bonding," which consists in connecting the rails together with copper wire by wedging or soldering the ends of a short piece of heavy copper wire into the web of adjoining rails. Cross connections between opposite rails should be made not less than every 150 feet. The method of bonding, by winding copper wire around the bolts before the fish-plates are put on, is not to be recommended.

**25. Arrangement and Protection of Conductors.**—From the end of the rails to the power house it is well to use a cable for the return circuit. Where the current is to be used exclusively for other purposes than traction, bare wires exposed for their entire length are not essential, and insulated cables may be used with the alternating system (single, two, or three phase) up to 1,000 volts potential. Current can be conveyed to central points at this pressure and converted at substations in the mine to the working voltage by means of static transformers. However, this would be done only where the distance from the mine shaft was considerable or where a large amount of current was used, making the cost of copper for conveying at 500 volts, without too great loss, a serious item of expense. The wires or cable should be placed at one side of the gallery, as much out of



the way as possible, to avoid injury to miner or mule (stock) from accidental contact. It is wise to conduct the current in any case through mains or feeders, and to have the system divided into sections with switches, so that the shutting down of one portion for repair or extension need not affect the balance. Where the wires cross main gangways, it is wise to protect them thoroughly against chance contact or mechanical injury; this may be done by covering them with split rubber hose and binding it at intervals with rubber tape.

**26. Carrying Capacity of Wires.**—The safe carrying capacity of wires is given in the following tables for bare wire and wire enclosed in moldings or conduits. The reason for the great difference in capacity is due to the fact that in one case the heat can radiate and in the other it accumulates.

**TABLE I.**  
**SAFE CARRYING CAPACITY OF BARE WIRES.**

Brown & Sharpe. Gauge Number.	Safe Carrying Capacity. Current in Amperes.
0000	300
000	245
00	215
0	190
1	160
2	135
3	115
4	100
5	90
6	80
7	67
8	60

**TABLE II.**  
**CARRYING CAPACITY OF WIRES WHEN ENCLOSED.**

Brown & Sharpe. Gauge Number.	Amperes.
0000	175
000	145
00	120
0	100
1	95
2	70
3	60
4	50
5	45
6	35
7	30
8	25

**27. Danger of Injury from Shock.**—It is not wise to touch a bare conductor carrying current at a pressure of over 110 volts, unless you are provided with gloves made of rubber or standing upon some dry insulating material. This fact should be remembered by persons traveling along headings where the conductors may be touched by some part of the body. A person wearing dry rubber boots or standing on dry wood may touch a single conductor through which a current of high voltage is passing without injury, provided he does not make contact with the negative conductor (generally the earth) with some exposed part of the body.

A dynamo or motor may become “charged” by injury to the wiring or on account of some loose coils touching the body of the machine. In such a case it is exceedingly dangerous to touch any part of the machine, for it will discharge through your body into the earth. It is a

wise precaution to connect the frames of pumps and other machines run by electricity to the earth to prevent their becoming charged and inflicting possible injury to those handling them.

---

## ELECTRIC HOISTING.

---

### GENERAL CONSIDERATION.

**28.** The electric motor is an ideal form of power engine for hoisting. Having a rotary motion, the intervention of a crank with its varying power at different positions is not necessary, as is the case with the use of steam or compressed air. Hoisting-engines used in mining are frequently located quite a distance from the boilers, necessitating great length of pipe for delivery of steam. In addition to the losses from condensation, there is constant danger of blowing out the cylinder-head from having water collected in it. As hoisting-engines are used intermittently, this will be a very serious source of trouble unless the engine and pipes are carefully drained before starting. In cold weather, ice may also form in the pipe and engine and cause accident. The electric-motor hoist reduces dangers from careless handling to a minimum.

---

### PRACTICAL EXAMPLES.

**29.** Fig. 7 shows a direct-current electric mining hoist. The motor is one of the armored railway type built by the General Electric Company. It is enclosed as shown, the case *a* forming part of the field magnet and protecting the machine from dust and dirt as well as mechanical injury. The controller *b* is of the street-car type, and is mounted so as to be convenient for the operator to observe the necessary signals. The current is regulated by the lever *c*, and

reversed when necessary by the lever *d*. The pinion upon the axis of the armature gears with the spur-wheel upon the shaft *e*. These gear-wheels are enclosed in the case *f*, which not only protects them from dust and dirt, but also furnishes a receptacle for oil, which insures continuous and perfect lubrication. On the right-hand end of the shaft *e* there is a pinion that gears with the large spur-wheel *h*,

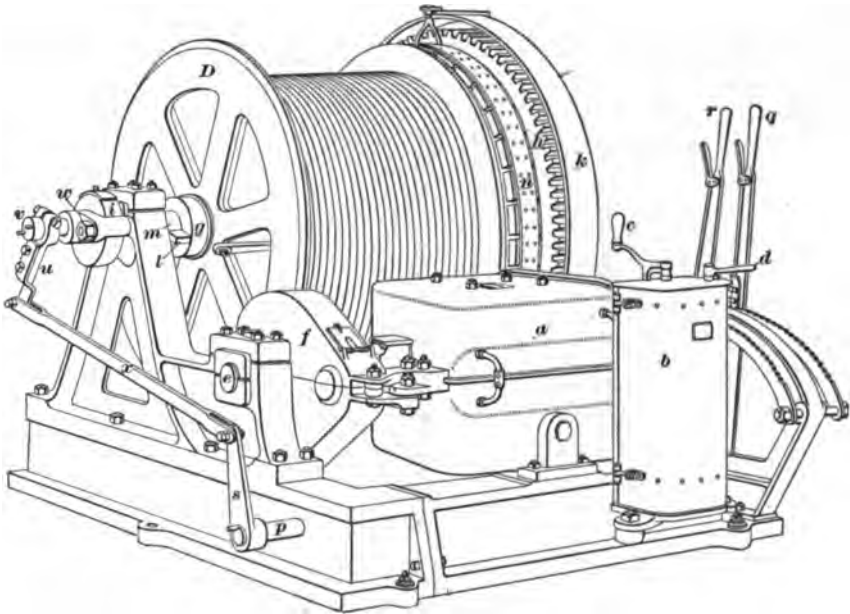

FIG. 7.

which is covered by the protective band *k*. The gear-wheel *h* is fixed rigidly to the drum shaft *m*, while the drum runs loosely upon it. The band brake *n*, which consists of a flat iron band having a number of wooden blocks attached to its inner side by means of wood-screws, engages with the drum and is applied or released by the lever *r*. The lever *q* operates the patent friction-clutch through the

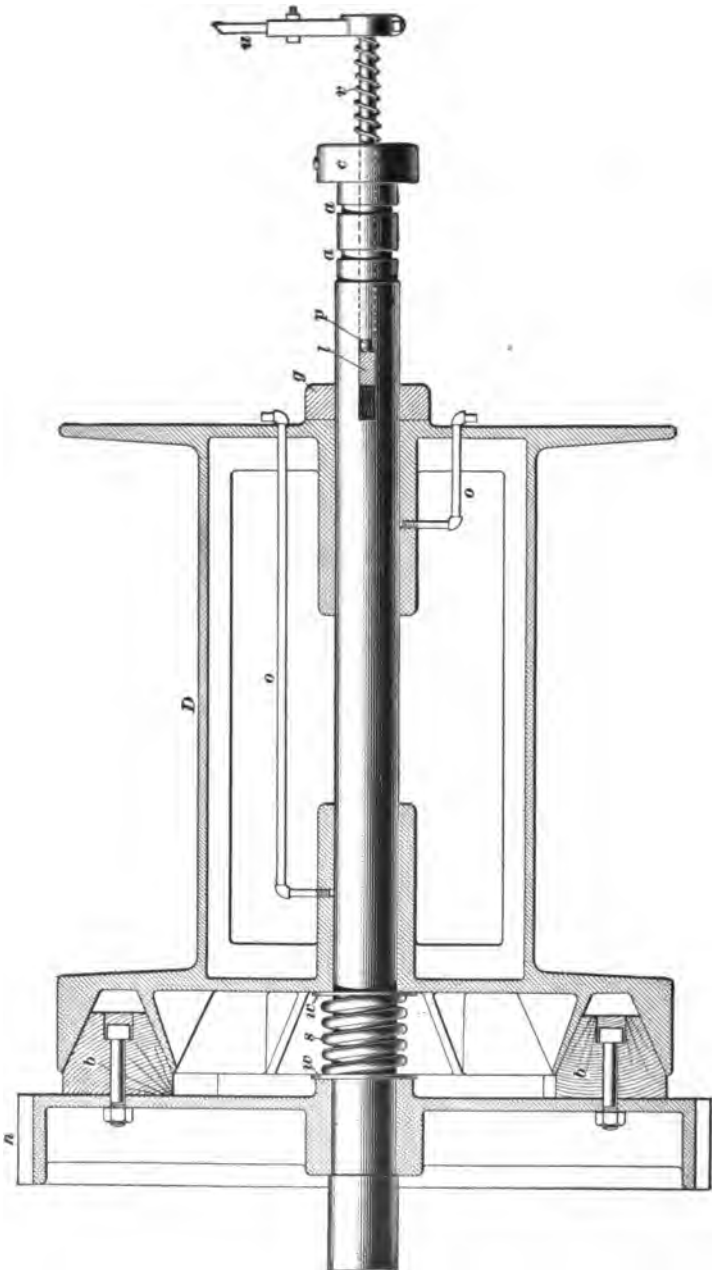

FIG. 8.

horizontal shaft  $p$ , the lever  $s$ , the link  $x$ , and the lever  $u$ . When the screw  $v$  is slightly turned by this system of levers, it is forced into the nut  $w$  and against the end of a concentric steel pin which passes through the shaft  $m$  to the cross-key  $l$ . This key then forces the washer  $g$  against the drum, which is pushed to the right and engages with the friction-clutch. The bearing between the end of the concentric pin and the screw is kept well lubricated by means of the oil case  $i$ .

**30.** Fig. 8 shows a section of the drum  $D$ , Fig. 7, illustrating the construction and action of the Beekman patent friction-clutch as built by the Lidgerwood Manufacturing Company, of New York. Large wooden blocks  $b$  are bolted to the side of the spur-wheel  $h$ , and they are made of suitable shape to conform to the V-shaped groove in the side of the drum  $D$ . The steel spring  $s$  between the two steel washers  $w, w$  disengages the brake as soon as the pressure is relieved from the opposite side of the drum. It can be clearly seen from the figure that, as was previously stated, when the lever  $u$  (Fig. 7) is turned, the screw  $v$  is forced against the end of the concentric steel pin  $p$ , which in turn presses the cross-key  $l$  against the collar  $g$ . This collar presses the side of the drum, which then frictionally engages with the large spur-wheel  $h$ . The drum shaft is prevented from moving longitudinally by means of the grooves  $a, a$  and the screw collar  $c$ . The wide bearings of the drum on its shaft are lubricated by means of the pipes  $o, o$ .

**31.** This hoist is provided with separate resistance to regulate the speed of the armature when the motor is working under different loads; it is especially suitable for a single shaft, for the friction-clutch can be used while hoisting the cage and the band brake used in lowering it, provided it is not necessary to reverse the current and use the power. The rope may coil upon the drum in several layers, unless the hoist is used to raise material out of two adjacent

shafts or a double shaft, in which case both ropes are attached to the middle of the drum and wind upon it towards the ends; or, better still, one rope may be attached at the middle and the other at the side of the drum, so that the stress will be placed more equally upon the bearings of the drum shaft. With this arrangement, the ropes can not be accurately or conveniently adjusted to make the rails on the cage at the top, and those on the cage at the bottom fall in line with the rails of the roads at the top and bottom.

**32.** After considerable use, the ropes vary in length, and rather than attempt to adjust one or the other of them, blocks are sometimes bolted to one end of the drum to increase its circumference and thereby take up the required amount of rope to land the cage properly and prevent undue jars and stresses when starting to hoist. In many large mining hoists, the ropes are adjusted by means of internal positive clutches. This arrangement is very convenient where the shafts are deep and the ropes necessarily long.

**33.** When two ropes are attached to a single drum, the length of rope is limited to the width of drum, as not more than one layer of rope can be wound upon the drum, while if double drums or single drums with one rope are used, several layers of rope may be coiled upon the drum. This, however, is not good practice in hoisting, although in haulage practice the rope usually winds upon itself. Hoisting drums are generally provided with spiral grooves, which guide the rope and furnish a good bed for it.

**34.** The hoist shown in Fig. 7 weighs about 24,000 pounds and can hoist 6,000 pounds (gross load) at a speed of 500 feet per minute. The drum has a 36-inch face and is 60 inches in diameter. The motor makes 700 revolutions per minute and is rated at 110 horsepower. Hoists of this type and size are used at small mines and for auxiliary hoisting at large mines. Motors are used to run large double drums instead of the steam-engine, but the conditions at the majority of mines are such as to make it uneconomical; for it

would not be good policy to incur the double cost of transforming the steam energy into electrical energy when steam can be used directly and near where it is generated.

**35.** Fig. 9 shows a direct-current electric mining hoist quite similar to that shown in Fig. 7, except that it has a

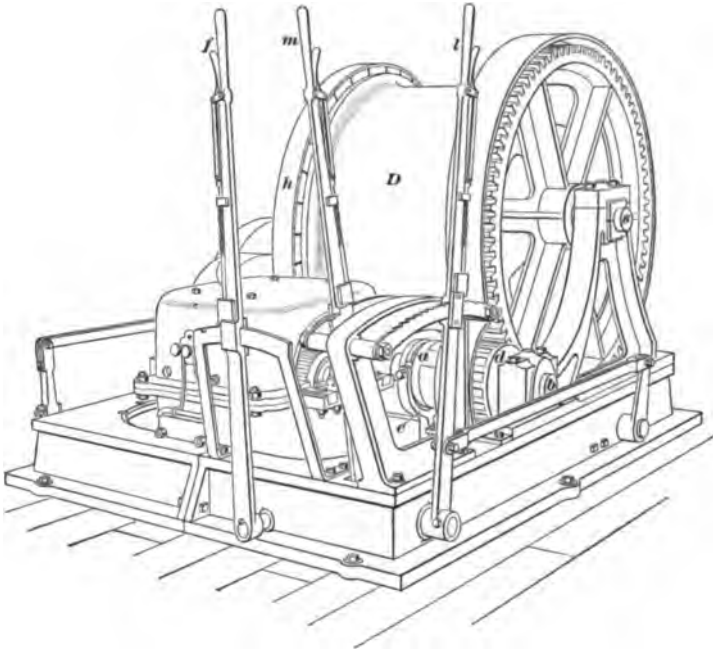
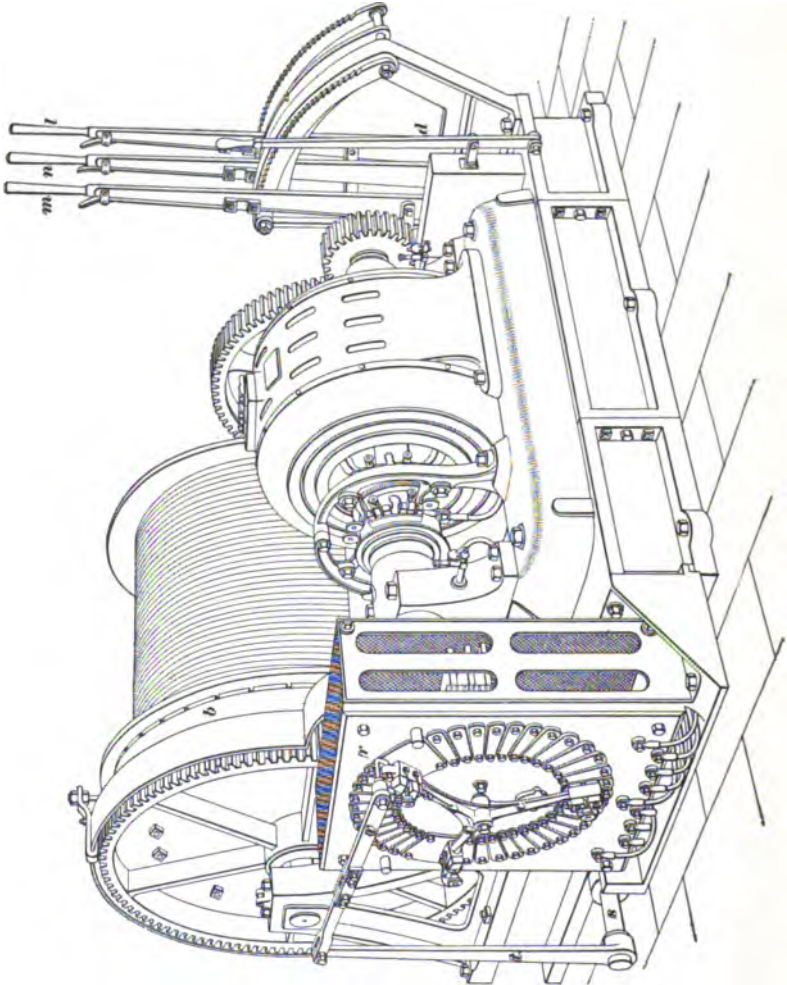

FIG. 9.

jaw clutch *a*, which moves longitudinally along the shaft *b* on a feather, which prevents it from turning except when the shaft turns. The drum *D* is fixed to the shaft *s*, and the pinion *d* is loose on the shaft *b*. The face of the clutch next the pinion *d* has a number of sectoral projections and recesses which fit into corresponding recesses and projections on the adjacent side of the pinion. The clutch is thrown in or out of gear by the bifurcated upright *e* which is operated by the hand lever *f*. The bifurcated ends of the upright have suitable projections bolted to them, which run



in the annular groove in the clutch *a*. This form of clutch is positive and can not be thrown in gear when the motor is running at any considerable speed unless the projections



and recesses have considerable play, in which case the entire hoist is subject to great stresses if the gear is thrown in while the motor is running.

The cage may be lowered by throwing the clutch out of gear and using the band brake *h*, which is operated by the hand lever *l*. The motor and the resistance are controlled by the hand lever *m*. This hoist is built to raise 6,000 pounds with current supplied at a voltage of from 250 to 500, and it is especially suitable for local hoisting in wet places. The face of the drum is smooth and the rope may wind upon itself.

**36.** Fig. 10 shows an induction-motor mining hoist provided with a patent friction drum operated by the lever *l* and a band brake *b* operated by the lever *m*. The motor is of the three-phase induction type and is provided with a resistance in the armature circuit and external contacts for varying the same. The motor may be wound for a voltage of from 110 to 500, and can be adapted for use on two or three phased systems. The controller is so constructed that a speed varying from maximum to zero can be obtained as readily as if a steam-engine were used. The external contact arms *c* are placed upon the resistance box *r*, and are operated by the hand lever *n*, through the horizontal shaft *s*, lever *t*, and link *v*. The current is reversed by the lever *d*.

**37.** Fig. 11 shows an electric hoist made by the Lambert Hoisting Engine Company, of Newark, New Jersey. The armored continuous-current motor *M* is connected to the pinion *u*, which gears with the spur-wheel *w*, on whose shaft there is a pinion that gears with the large spur-wheel *s*. The current is regulated by the small crank *a* on the controller *C*. This hoist is provided with a patent friction-clutch that is operated by the lever *l*; also the band brake *b*, operated by the lever *p*. The gear-wheels are covered with bands *c* and *f*, in order to prevent anything from falling between them.

**38.** Fig. 12 shows a double independent drum hoist having an induction motor *M* and controller *C*, which are similar to those shown in Fig. 10. The levers for controlling the patent friction-clutches and band brakes and the

lever on the controller are all placed so as to be convenient for the operator, who stands upon a platform above the floor

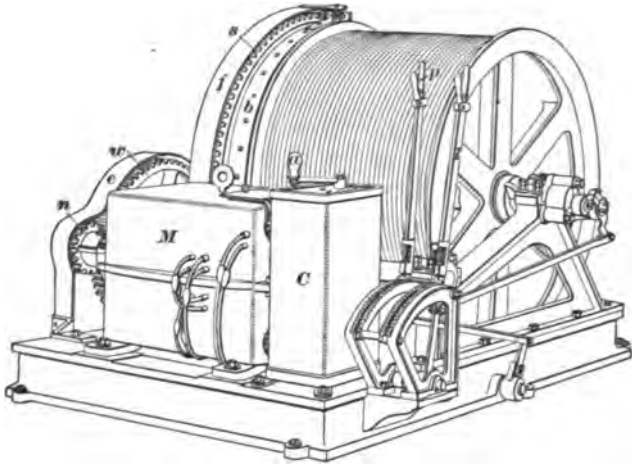

FIG. 11.

in order to get a clear view over the top of the hoist. Each friction drum is driven through a single-reduction gearing

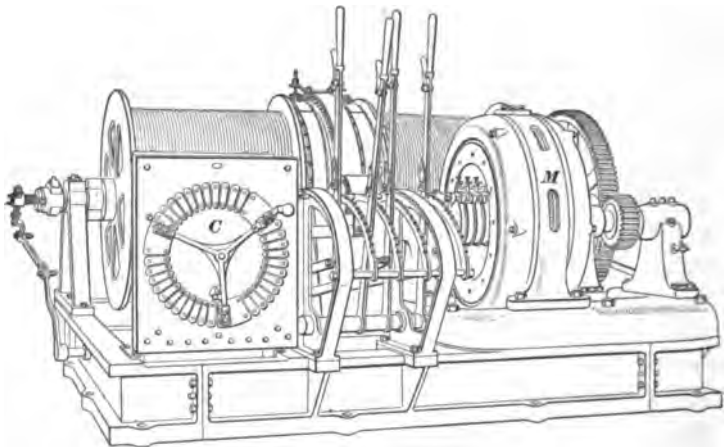

FIG. 12.

by a 100-volt 12-pole induction motor of 30 horsepower running at 600 revolutions per minute. Each drum is

independent and of 42 inches diameter, has a 40-inch face, and will wind about 420 feet of  $\frac{1}{4}$ -inch rope. The maximum hoisting speed is 300 feet per minute and the weight hoisted, including load, car, and cage, is 2,100 pounds. The depth from which the load is hoisted is 400 feet from the surface.

---

## ELECTRIC HAULAGE.

**39. General Consideration.**—Electric motors may be employed for operating drums for tail-rope, endless-rope, or other haulage systems, but these could not properly be called systems of electric haulage, as the electric motors can be replaced by engines without affecting the means of drawing the cars. In the present treatment of the subject, electric haulage is taken to mean a system by means of which the motors are placed upon electric locomotives and travel with the cars.

**40.** Haulage in mines is usually accomplished in two divisions. The cars are hauled between the shaft bottom or outside landing, and the turnout near the working places in the mine by means of the main system, and between the turnout and the different working places by means of mules or horses. These divisions are called the general and the local haulage, respectively. The former is done in large trips and the latter in small trips of from one to ten cars, and consists in hauling the empty cars in and the loaded ones from the working places. In some mines the local haulage, which is often termed **gathering**, is partially done by electric locomotives; but in such cases, electricity is used for running the mining machines, the trolley-wire being also used to conduct the current to the machines. Gathering with locomotives operated by a trolley has not been entirely successful. The storage-battery locomotive is now being experimented with and bids fair to prove successful in this work.

**41. Advantages of the Electric Locomotive.**—The compactness of the electric locomotive and the fact that

it can run in lower entries than either the steam locomotive or the mule make it specially advantageous for mine operations. The mechanism can also be better protected from injury and is more readily accessible for repair. All working parts, with the exception of the controlling mechanism, are practically enclosed in a heavy, rigid, cast-iron frame, and heavy metal or wooden doors on the top of the frame secure the parts from damage by water or falling rock from the roof.

**42. Construction and Arrangement of Mine Locomotives.**—Motors constructed for mine locomotives are generally of the iron-clad, single-reduction-gear type, with the gearing running in tight cases containing oil. The motors are controlled by either the rheostat (resistance method) or by a series-parallel controller. In the latter, the current passes, on the first movement of the lever, through a temporary resistance, then through each motor in series. The resistance is then cut out, either by the next position of the lever or in successive steps. The motors are then thrown in parallel, that is, the current passes through each one separately with an added resistance; the final step cuts out this resistance. It is evident that with 500 volts on the line when the motors are placed in series, each one gets the equivalent of 250 volts, and when in parallel, each has the benefit of the 500 volts on the line. It is very essential that the resistance used with the controller should be of sufficient carrying capacity not to overheat if the operator carelessly allows the motors to run with the controller in such position as to include it.

**43.** Apparatus for mines should be constructed with a view to running without chance of breakdown under the most unfavorable conditions rather than under proper ones. Among careless mechanics and operators there is always temptation to neglect the apparatus as long as it will run. Too much stress can not be laid upon the importance of constant inspection and attention.

**44. Speeds.**—Electric locomotives for mines are generally designed to run at speeds of from 5 to 10 miles an hour, and most of the standard makes are designed to run at 6 miles an hour at their maximum power.

**45. Electric Locomotives vs. The Mule.**—Often a single electric locomotive can handle the entire haulage of a mine and replace the work of many mules. The latter constantly block each other in main gangways when material is collected from many galleries, and as the output of a mine is often limited by the amount of material that can be hauled out through the main passage, the greater speed of the locomotive and its ability to haul in one load many times the number of cars that a mule is capable of will frequently greatly increase the output of a mine and materially cheapen the general cost of production. Then, again, where the seam or vein is thin, the locomotive can operate with a headroom of 3 feet 6 inches to 4 feet, while the mule will require over 5 feet. Another advantage is that the locomotive can work for 24 hours, if necessary, without getting tired, while several shifts of mules would be required, with the consequent trouble of feeding and accommodating a large number of animals underground or occasioning delay in hoisting them to the surface.

**46. Electric vs. Rope Haulage.**—It is a difficult matter to compare the relative advantages of rope and locomotive haulage, for this question will depend upon so many minor details; but it is certain that locomotive haulage will not be available where there are grades of over 5%, as the traction-engine can haul on this grade only about one-tenth of the capacity which it can haul on a level track. The energy expended in overcoming the weight of the locomotive and cars takes the major part of this capacity. With rope haulage, the load factor of the cars is the only one which is to be considered.

**47. Size and Capacity of Electric Locomotives.**  
—Electric locomotives are always operated by direct-current

**TABLE III.**  
**LIMITING DIMENSIONS OF DOUBLE-END BALDWIN-WESTINGHOUSE MINE LOCOMOTIVES.**  
**LOCOMOTIVES HAVING OUTSIDE FRAMES.**

CLASS.	Min. Gauge. Inches.	Diam. of Drivers. Inches.	WHEEL-BASE.		Height Exclusive of Trolley. Inches.	Minimum Width. Inches.	Max. Gauge for Min. Width. Inches.	Length Excluding Bumpers.	Weight. Pounds.
			Motors Tandem. Inches.	Motors Central. Inches.					
4 $\frac{1}{2}$ C	20	20	30	38	24	37	20	10' 8"	4,000
4 $\frac{7}{16}$ C	24	24	40	46	32	43	25	11' 4"	7,500
4 $\frac{9}{16}$ C	30	28	40	50	34	50	32	11' 6"	7,500
4 $\frac{11}{16}$ C	30	28	44	52	34	51	32	11' 10"	10,000
4 $\frac{3}{8}$ C	30	30	44	54	36	52	32	12' 0"	15,000
4 $\frac{5}{8}$ C	35	30	48	56	38	58	40	12' 0"	20,000
4 $\frac{7}{8}$ C	35	30	48	56	38	59	40	12' 0"	26,000

**LOCOMOTIVES HAVING INSIDE FRAMES.**

CLASS.	Min. Gauge. Inches.	Diam. of Drivers. Inches.	WHEEL-BASE.		Height Exclusive of Trolley. Inches.	Minimum Width. Inches.	Max. Gauge for Min. Width. Inches.	Length Excluding Bumpers.	Weight. Pounds.
			Motors Tandem. Inches.	Motors Central. Inches.					
4 $\frac{1}{2}$ C	29	20	30	38	24	35	29	10' 8"	4,000
4 $\frac{7}{16}$ C	34	24	40	46	32	41	35	11' 4"	7,500
4 $\frac{9}{16}$ C	40	28	40	50	34	48	42	11' 6"	7,500
4 $\frac{11}{16}$ C	41	28	44	52	34	49	43	11' 10"	10,000
4 $\frac{3}{8}$ C	43	30	44	54	36	50	44	12' 0"	15,000
4 $\frac{5}{8}$ C	48	30	48	56	38	56	50	12' 0"	20,000
4 $\frac{7}{8}$ C	49	30	48	56	38	57	51	12' 0"	26,000

TABLE IV.  
JEFFREY ELECTRIC LOCOMOTIVES.

Type.	Class.	Drawbar Pull. Pounds.	Speed in Miles per Hour.	Number of Motors.	H. P. of each Motor.	Weight of Locomotive. Pounds.	Minimum Gauge. Inches.	Min. Gauge with Outside Wheels. Inches.	Width over all with Inside Wheels. Minimum Gauge. Inches.	Width over all with Outside Wheels. Minimum Gauge. Inches.	Height over all Excluding Trolley. Inches.	Length over all Excluding Bumpers.	Wheel-Base. Inches.	Diam. of Wheels. Inches.	Lightest Steel Rail To Be Used. Pounds.
S M	10	500	6 to 10	1	10	4,000	22	84	40	40	86	7' 4"	80	24	8
"	20	1,000	"	1	20	8,000	36	48	55	55	88	7' 9"	85	28	12
D M	20	1,000	"	2	10	8,000	18	30	87	86	86	9' 8"	86	24	12
"	30	1,500	"	2	20	12,000	28½	45½	48½	51½	89	9' 4"	40	28	16
"	40	2,000	"	2	25	14,000	28½	45½	48½	51½	89	9' 4"	40	28	20
"	50	2,500	"	2	30	16,000	36	53	56	59	89	9' 4"	40	28	25
"	60	3,000	"	2	35	18,000	36	53	56	59	89	9' 4"	40	28	30
"	70	3,500	"	2	40	20,000	36	53	56	59	89	9' 4"	40	28	30
"	100	4,500	"	2	50	24,000	40	57	60	63	48½	10' 10"	40	28	40
T M	110	5,500	"	3	35	30,000	39	53	59	59	46	11' 8"	62	28	40



motors. Up to the present time no system has been devised to utilize the alternating current to advantage. Electric mine locomotives are now made in sizes ranging from 4,000 pounds in weight with a drawbar pull of 500 pounds and running at a speed of 6 to 10 miles per hour, to 30,000 pounds in weight, 5,500 pounds drawbar pull. They are made in two forms, with outside and inside wheels; that is, the wheels are located inside the heavy cast-iron frame in one case, outside in the other. The minimum gauge is 18 inches, but tracks of this width are not to be recommended.

Outside dimensions range from 34 inches up. The preceding tables give the prevailing dimensions.

**48. Effect of Grade Upon Capacity.**—In modern steam-railway practice, a ton weight of train can be hauled

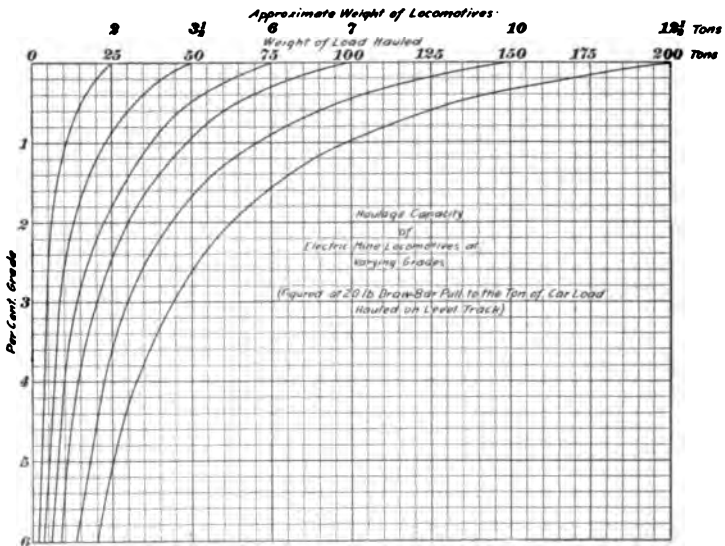

FIG. 18.

at 20 miles an hour over 80 to 100 pound rails with good roadbed for every 3½ pounds of drawbar pull exerted by the locomotive. With old-style light rails used twenty years

ago on the large railroads, a drawbar pull of from 6 to 8 pounds per ton was required. In mine haulage, at least 20 pounds must be figured on, and with careless construction and badly oiled and adjusted car axles, this will run to 75 pounds and over. Attention is called to the diagram, Fig. 13, showing the rapidly decreasing capacity of locomotives with increase of grade. This is figured on the basis of 20 pounds drawbar pull to the ton, on level track, which can only be accomplished with rolling stock in good condition.

**49. Curves** offer a large increase of resistance to the locomotive and cars, and consequently they very rapidly decrease the hauling capacity with the shortening of the radius. Of course, the combination of grade and curve will effect the economic operation of the entire road. Under any circumstances, labor expended in keeping the track and journal-bearings in the best of condition will be amply repaid by the greater efficiency and capacity secured.

---

**ADVANTAGE OF HEAVY RAILS.**

**50.** In locomotive mine haulage, too much stress can not be laid upon the necessity of having the rails of sufficient size and weight so that they will not give under the weight of the locomotive and cars; also, for permanent working, the wisdom of having the best possible track construction.

The running of a locomotive or of heavily loaded cars with flat wheels over light rails will often effect a permanent set in the rail which will greatly increase the frictional loss and add to the wear and tear on rolling stock.

The following table gives the minimum weight of steel **T** rails admissible for the different weights of locomotives. These figures are the minimum allowable, and greater economy in operation is effected by a liberal increase in these weights.

TABLE V.

Tons.	Pounds per Yard.
4	10
5	16
7½	20
10	25
13	30

**EXAMPLES OF ELECTRIC LOCOMOTIVES.**

**51.** Fig. 14 shows an electric locomotive made by the General Electric Company. It is of 40 horsepower and has a drawbar pull of 1,500 pounds. The track upon which this machine runs is made of 30-pound rails tied together with heavy fish-plates and laid on 6-inch square ties. The trolley-pole, which is held against the trolley-wire through all its variations of height by means of a spring, is placed to one side in order to have the overhead wire near the side of the entry. This form of trolley-pole does not need to be changed in position in order to run the locomotive either way. The controller is of the street-car type, and sufficient resistance is provided to prevent damage on starting the load. A magnetic blowout is used to avoid serious arcing at the contacts.

There are two motors, one for each pair of drivers. They have single-reduction gearing, and each is suspended by two bearings on the axle, which are kept well lubricated, and by an attachment to the front of the frame, which permits a slight lateral and endwise movement in case the main frame moves with respect to the axles. With this method of suspending the motors, one end of each supporting frame is practically suspended on springs, for it is attached to the main frame which rests upon helical springs placed upon the journal boxes, and the other end rests upon the axles and keeps

the pinion on the armature shaft always in perfect gear with the spur-wheel on the driver shaft, no matter how much the front end of the frame supporting the motor may be moved up and down while the locomotive is running. The frame is made of very heavy cast-iron side and end pieces for the purpose of obtaining great weight in order that the locomotive will have sufficient adhesion to the rails. The journal boxes are provided with bronze bearings and oil-wells for

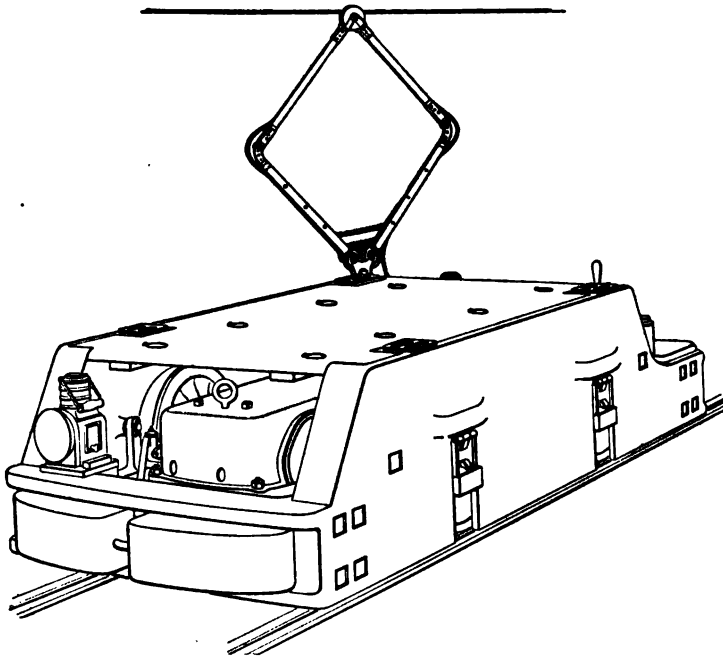

FIG. 14.

holding the saturated cotton waste. The massive frame is supported on helical springs resting upon the journal boxes. The use of the springs is to relieve the machine and rails from destructive shocks, and consequently prevent much wear and tear to both. This locomotive, in general with other types, is provided with a headlight, sand boxes, and a good brake. The speed varies from 6 to 10 miles per hour, depending upon the weight of the load and the grades.

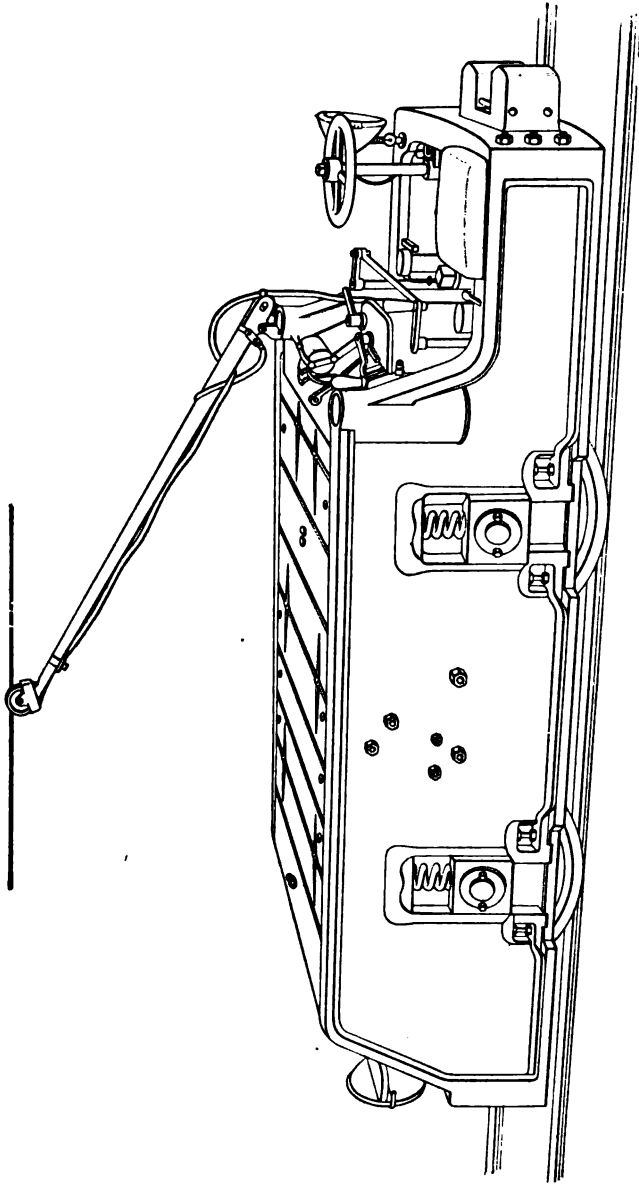

FIG. 15.

**52.** Fig. 15 shows an electric mine locomotive built by the Baldwin-Westinghouse Electric and Manufacturing Company. They are built in sizes from 20 to 150 horsepower, to run at an average speed of 8 miles per hour. They vary in weight from 7,000 to 34,000 pounds.

**53.** Mine locomotives are also manufactured so arranged that the operator sits in the center of the frame between the two axles, being surrounded by the heavy casting, and thus protected from injury in case of a collision with anything standing on the track. This style of locomotive is manufactured quite extensively by the Jeffrey Manufacturing Company, of Columbus, Ohio.

**54.** Mine locomotives have generally been made with two pairs of wheels, with a motor mounted on each of the two axles. A recent type, however, has six wheels, each pair with its separate motor, attached by single-reduction gearing. It is claimed that in this design the weight is distributed better over the track, causing less strain to it, and that the additional pair of drivers gives a largely increased traction. To enable this six-wheel locomotive, with its longer wheel-base, to operate on short-radius curves, the center pair of wheels are made without flanges, that is, with smooth face.



# ELECTRIC PUMPING, SIGNALING, AND LIGHTING.

---

## PUMPING.

**1. The drainage of mines** is one of the most difficult problems in mining operations. Even if not encountered at the start, water-bearing ground is likely to be met with as the work progresses. The pumping plant should always have a large reserve capacity, since the extension of operations is likely to bring with it a larger amount of water to be handled. Where other mines have been operated in the neighborhood to greater depth, some light may be thrown on the probable requirements. Whether the water should be collected in the lowest level or pumped from each level separately depends on the question whether economy or simplicity is the main object, and this may be decided by the amount of flow.

**2. Conditions.**—The operation of a shaft mine in which water collects depends upon the ability to keep the working parts free from the accumulation of any large amount of water, and the pumps should be constructed and arranged so as to offer the smallest possible chance of failure. They should be capable of running a long time without requiring packing or repair, and the sinking-pumps and those located in the lowest level should be capable of running under water. Where acid water is encountered or where there is much grit in the water, the pump should be capable of handling it without too rapid wear.

The operation of pumps is influenced by many conditions, such as the length and size of the suction-pipe, the number



of angles or turns in the pipe, the barometric pressure, temperature of the water, and altitude at which plant is located. The smoothness of the inside of the pipe and the diameter will also greatly affect the capacity and efficiency.

**3. Comparison of Systems of Pumping.**—The various styles of pumps and the arrangement of parts have been quite fully described in *Hydromechanics and Pumping*. The advantages of inside and outside packing, of direct-acting and fly-wheel pumps, and other facts regarding pumping machinery are there thoroughly treated. For the present we have to deal with electric pumps only; but it may not be amiss to state under what conditions the electric system is superior to the other systems. If there is but a limited amount of pumping to be done, it is not advisable to install any very expensive plant, as the interest on the cost might exceed the operating expense, and hence for such cases the water may be removed by means of water buckets, water cars, or pumps driven by steam or compressed air.

**4. Steam Consumption of Steam-Pumps.**—The duty of steam-pumps is approximately as follows: For small sizes, the consumption of steam is from 130 pounds to 200 pounds per horsepower per hour when operating in the workings of a mine at some distance from the boiler. For larger sizes of simple steam-pumps, the consumption is from 80 pounds to 130 pounds of steam per horsepower per hour. Compound condensing pumps, such as are commonly employed at stations in mines, consume from 40 pounds to 70 pounds of steam per horsepower per hour, while triple-expansion, condensing, high-class pumping-engines consume from 24 pounds to 26 pounds of steam per horsepower per hour. From these figures, it will be seen that, especially in the case of dipping pumps, which throw water to the main sump of a mine, the steam consumption is very great indeed.

**5. Steam Consumption of Electric Pumps.**—The duty of electrically driven pumps may be taken as follows: When a compound condensing engine is employed upon the surface operating electric pumps underground, the steam

consumption per horsepower per hour for the smaller sizes would be about 40 pounds per horsepower per hour, for medium-sized electric pumps about 30 pounds per horsepower per hour, and for larger sizes from 20 to 30 pounds per horsepower per hour. It will be seen from these figures that for pumping from isolated portions of the mine, electric pumps are much more efficient than steam-pumps.

**6. Advantages of Electric Pumping.** — When steam-pumps are employed underground, the pipes are very objectionable in the mine, owing to the heat which they impart to the workings. It is also difficult to dispose of the exhaust-steam, and the entire system is liable to injuries. In case of accident, as, for instance, the sudden breaking into the mine of a considerable flow of water, it is difficult to assemble the pumps or rearrange them so as to meet the new conditions, on account of the fact that it takes some time to couple up the necessary steam or air pipes. The objections in regard to heat do not apply to compressed-air pumps, but the objections in regard to flexibility of system apply equally. With electric pumps, the system is always semiportable, owing to the fact that the conductors can be strung easily and quickly and the pump moved with ease and rapidity. Then, too, when either steam or compressed air is employed, there is a great loss in the transmission line, owing to the fact that the air can not, as a rule, be reheated previous to use and that there is a great condensation in the steam line. In the case of electric pumping, the power can be furnished by a generator directly connected to an engine on the surface, thus affording the most efficient power-generation plant possible. If the mine contains many small pumps, the total efficiency of the system when driven by electricity will be very much above that of a mine provided with a high-class pumping-engine at the foot of the shaft and several compressed-air or steam-driven pumps throughout the workings. Another advantage is that the electrically driven pumps need very little attention, it being possible to place them in charge of some one who simply visits them

occasionally to see if they are working properly and to oil them. In mines where electricity is used for lighting, electric traction, or other power purposes, the pumping system fits in to the electric system already installed, and hence the whole may form a very efficient arrangement. One very important point in connection with electric pumping is that electric motors can be arranged to run at a uniform speed through a considerable range of load, so that if the pump were to work on air at times it would not result in any serious damage to the machinery; while if this occurs with a direct-connected steam-pump, there is danger of serious hammering or breaking of the pump, owing to the fact that the ram or piston jumps forwards on account of the air and strikes a destructive blow upon the water. This point is very important in the case of pumps placed in isolated portions of the mine to throw water to the main sump, as these pumps are frequently left to take care of themselves for a whole day at a time.

**7. Centrifugal Pumps.**—Centrifugal pumps may be driven by electricity, but they are only suitable for short lifts, the maximum efficiency being attained for a lift of approximately 17 feet. Another disadvantage of the centrifugal pump lies in the fact that it is only efficient when driven at the speed for which it is designed to work and when operating against the head for which it is designed, and any change of speed or head reduces the efficiency very rapidly. One advantage of the centrifugal pump is that it can safely pass gritty water or even small stones without damage.

**8. General Construction and Form of Packing Employed.**—Electricity may be used to operate either piston or plunger pumps, but for mine work piston-pumps are not efficient and are rarely used except in isolated cases for dipping from stopes which are below the general drainage level of the mine, the objection to the piston-pumps being the rapid wear and consequent leakage from one side of the piston to the other. Ordinarily, electric pumps are

of the plunger type having outside packing, and may be arranged as duplex or triplex pumps, i. e., two or three cylinders placed side by side and so arranged that their cranks stand at angles of  $90^\circ$  for the duplex and  $120^\circ$  for the triplex. One advantage claimed for the steam and compressed-air pumps is that with their use the reciprocating motion can be obtained without the intervention of gearing, which is necessary in all electric pumps; but the loss due to this cause is much less than the loss in the steam or air cylinder due to the large amount of clearance in all pumps using these mediums which are not provided with fly-wheels.

**9. Gearing.**—The rotative motion of the motor is transformed into a reciprocating motion of the pump by means of a series of gears, this being necessary on account of the fact that efficient motors can not be manufactured which can be run at a sufficiently slow speed so that they may be attached to the crank-shaft of the pump. The reciprocating motion may be obtained by either single or double reduction gearing. In the former case, a pinion is attached to the armature of the motor, which engages a large gear on the crank-shaft. The latter case is illustrated by Fig. 1, and in this case a pinion on the armature shaft drives the large gear *c* upon the shaft *a*. The gear *b* is also placed on the shaft *a* and drives the large gear *d* upon the crank-shaft. In the double-reduction gearing, a high-speed motor is employed, and an efficiency of from 65% to 70% of the power delivered to the electric motor is obtained in the horsepower output of the water. With the single-reduction gearing, an efficiency of from 70% to 75% can be obtained for lifts of over 300 feet, below which height the efficiency drops very rapidly, becoming 60% or less for 100 feet. Of course the water is thrown from the mine to the surface at a less expense per gallon from the shallow opening than from the deep opening, but, as has been stated, the total efficiency expressed in foot-pounds is less. The discovery of this fact has led more and more to the doing away with the station pumps in the shafts and

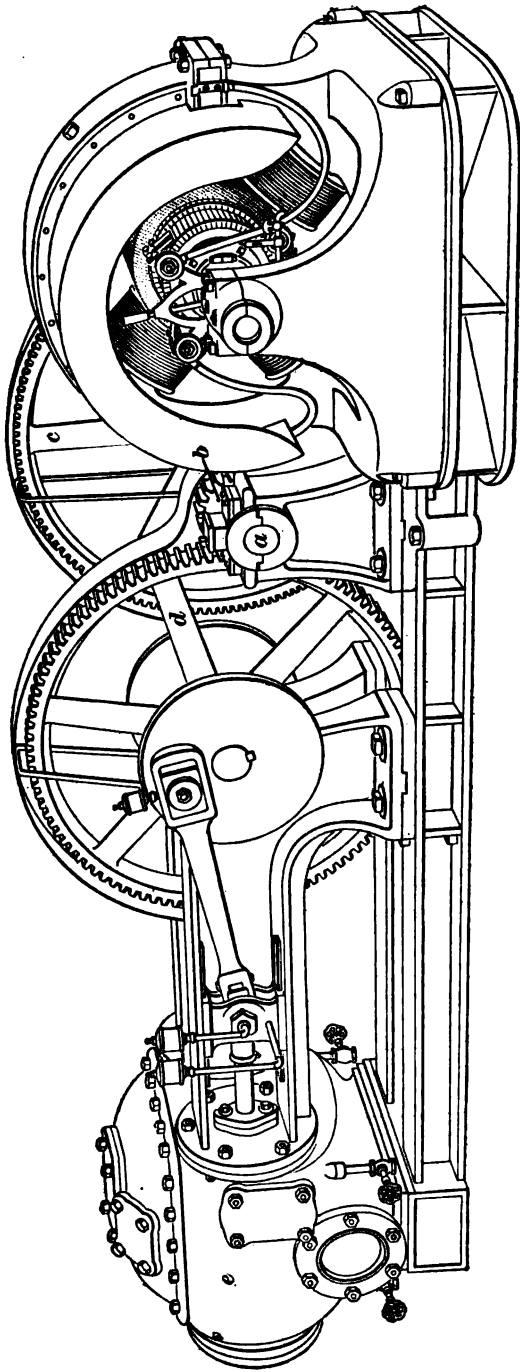

FIG. 1.

has been influential in increasing the practice of throwing the water to the surface at one lift, even when this is as great as 1,300 or 1,400 feet.

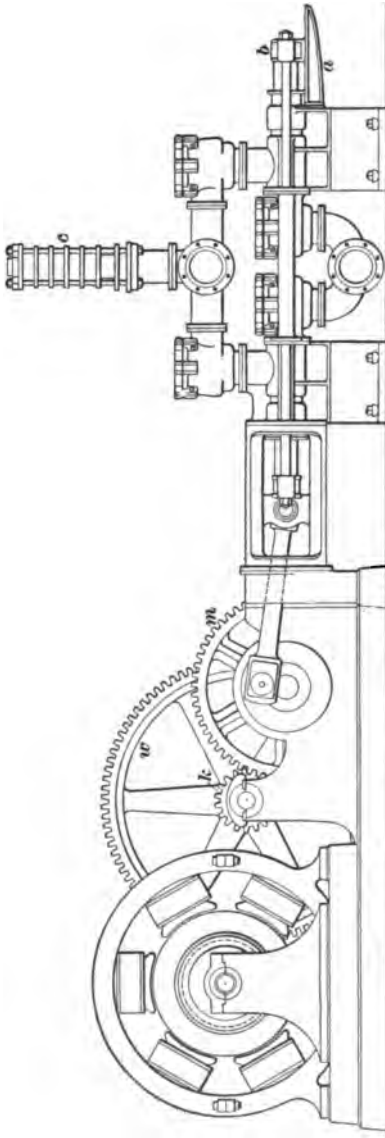

FIG. 2.

**10.** The pump shown in Fig. 1 is a Knowles double-reduction pump driven by a 4-pole direct-current motor, which is mounted upon an extension of the pump bed-plate, as shown at the right of the drawing. At the left of the drawing, cylinders *c* are shown. There are two of these cylinders, arranged with their cranks at  $90^\circ$ , both taking water from a common suction and discharging into a common discharge. This pump is fitted with inside-packed pistons, and hence not suited for gritty waters, though it may be somewhat cheaper than the plunger type.

**11. Triplex Outside-Packed Pump.—**

Fig. 2 illustrates a mine pump manufactured by the Janesville Iron Works Company, having a large 6-pole motor mounted upon a bed-plate, as shown to the left of the illustration. This motor

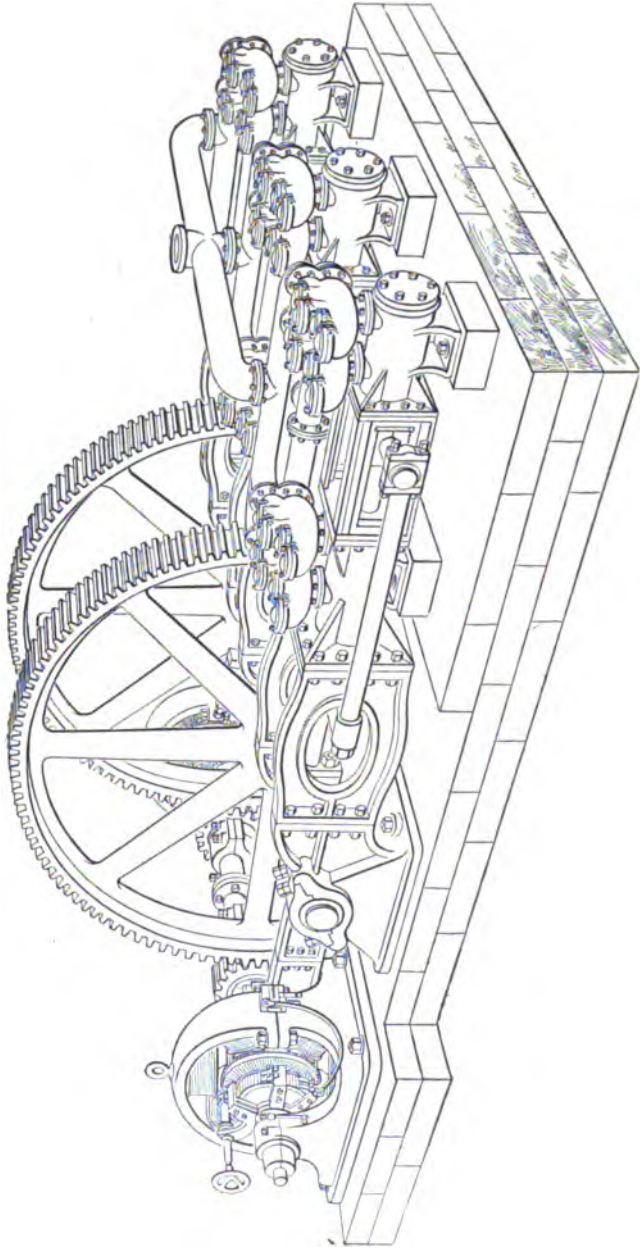

FIG. 8.

has a pinion upon its armature shaft which engages the large gear-wheel *w* upon the same shaft with the pinion *k*. The pinion *k* drives the gear *m* upon the crank-shaft of the pump. There are three cranks, placed at an angle of  $120^\circ$ , and the pump has six single-acting, outside-packed plungers, three at each end. The cross-heads for working the back plungers operate upon tail supports *a*, as shown at *b*. These cross-heads *b* are driven by means of parallel rods, which pass from the main cross-heads to the rear cross-heads on each side of the pump frame. This pump is intended for lifting 1,200 gallons per minute to a height of 1,100 feet. No air-cylinder is employed, on account of the fact that the large number of displacements causes a practically continuous flow; but to guard against accidents from the stoppage of the column pipe, spring relief-valves are placed as shown at *c*.

**12. Center-Packed Pumps.**—A slightly different form of triplex electric pump is illustrated by Fig. 3, which is a Worthington pump. The capacity of this pump is 1,000 gallons per minute against a head of 1,000 feet, requiring over 250 actual horsepower. The water end consists of six single-acting, outside-packed plungers arranged in pairs, so that the packing comes between the adjacent cylinder-heads in place of at the outside ends of the cylinder-heads. This makes the packing a little harder to inspect than when it is placed at the outer ends of the cylinders, but at the same time does away with the tail rods and tail-rod supports, thus simplifying the machine. Both plungers are driven from the ends of the parallel rods, and each plunger really acts as a tail rod to support the other, thus doing away with the necessity of any guides between the adjacent cylinder-heads. The motive power is furnished by two electric motors coupled directly to the countershaft and driving the pump through a double set of single-reduction gears. The cranks operating the cross-heads and plungers are set at an angle of  $120^\circ$ .

**13. Triplex Pump Without Tail-Rod Supports.**—A design of pump intended for comparatively small



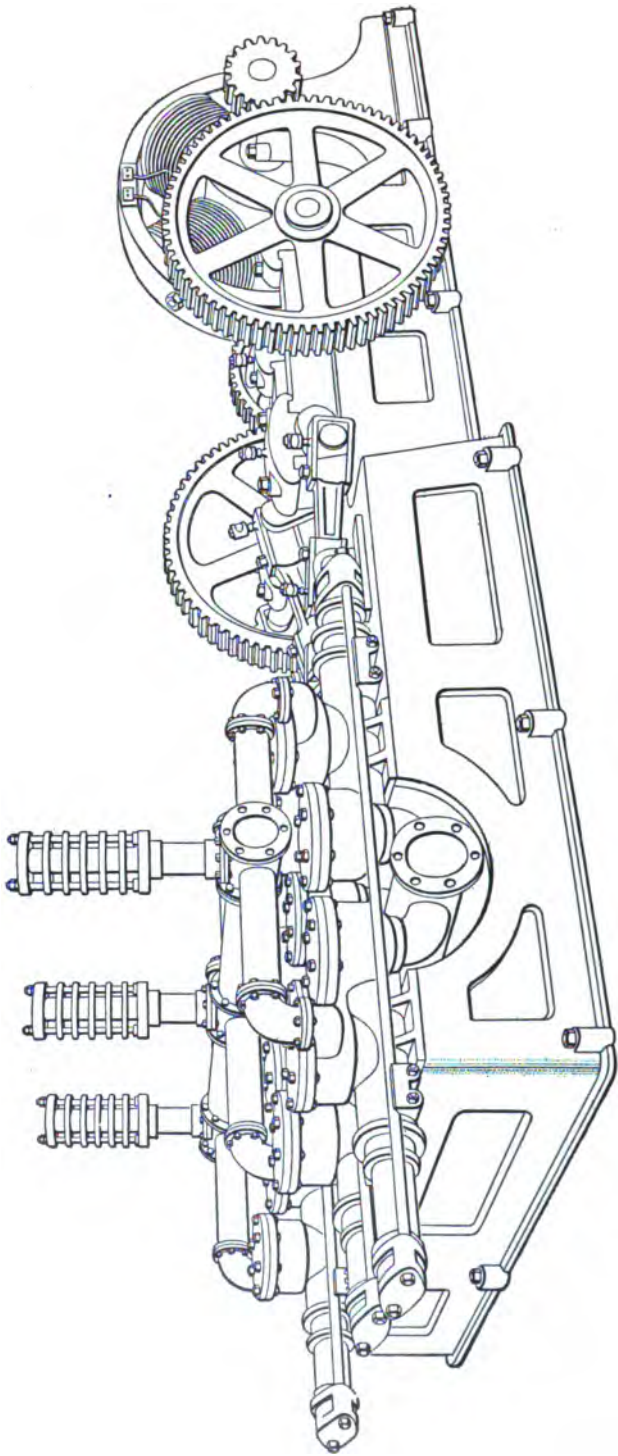

FIG. 4

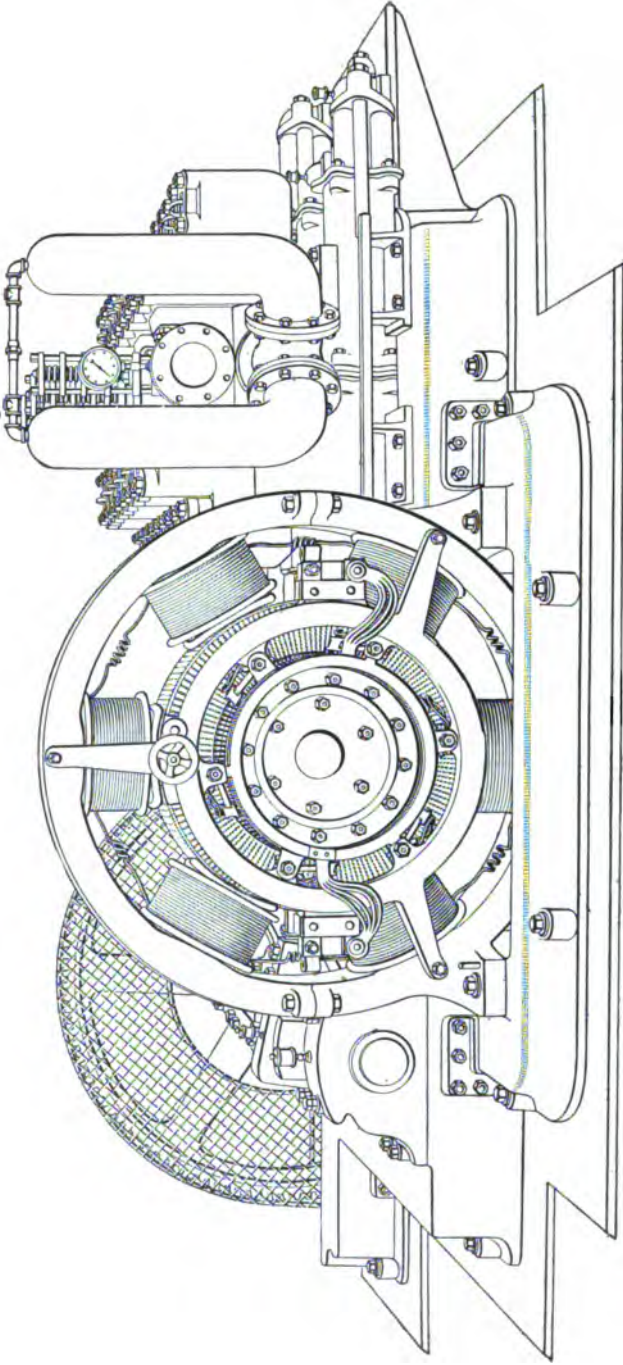

FIG. 5.

installations is shown in Fig. 4. Pumps of this style are built having a capacity ranging from 300 to 3,000 gallons against heads up to 600 feet. Spring relief-valves are employed, as in the form shown in Fig. 2. The gearing is also similar to the form illustrated in Fig. 2, but it will be noticed that the rams are not provided with any cross-heads or tail-rod supports at the left of the illustration, the packing bushings being made very long and depended upon as guides. The parallel rods for transmitting motion from the front to the back rams are shown very plainly, one of them being shown for its entire length along the sides of the pump-cylinder.

**14. Single-Reduction Geared Pump.**—Fig. 5 illustrates a Knowles double-acting, outside-packed plunger-pump which is driven by the General Electric Company slow-speed motor and a single-reduction gearing. The capacity of this pump is 500 gallons per minute against a head of 650 feet. It will be noticed that this pump is provided with spring relief-valves and with tail-rod supports for the plungers. The gearing is also enclosed in a casing, so as to protect the pump runner from injury. The manner of placing the motor makes the arrangement very compact.

**15. Partially Enclosed Sinking-Pump.**—Fig. 6 shows an electric sinking-pump provided with a 20-horse-power enclosed induction motor *m*. As this type of motor has no commutator or brushes, it can be encased to keep out water, and therefore the pump can be worked under water as well as above it. The armature shaft and the starting lever *l* pass through stuffing-boxes. This pump is of the duplex, double-acting type, and the power is transferred from the motor to the pump by means of double-reduction spur-gears, the arrangement of which can easily be understood by referring to the figure. The pump is suspended in the shaft by a cable attached to the eye-bolts *a*, and fixed in place by the supporting shoulders *b*. The suction-pipe *s* leads to the sump and the discharge-pipe *d* to the top of the shaft, or, in the case of deep shafts, to a

force-pump placed at some point in the shaft. The three

cables *c*, which are used to conduct the alternating current to the induction motor, are well insulated and also made waterproof. The air-chamber *h* makes the discharge more uniform and prevents shocks due to sudden changes in the velocity of the column of water in the discharge-pipe.

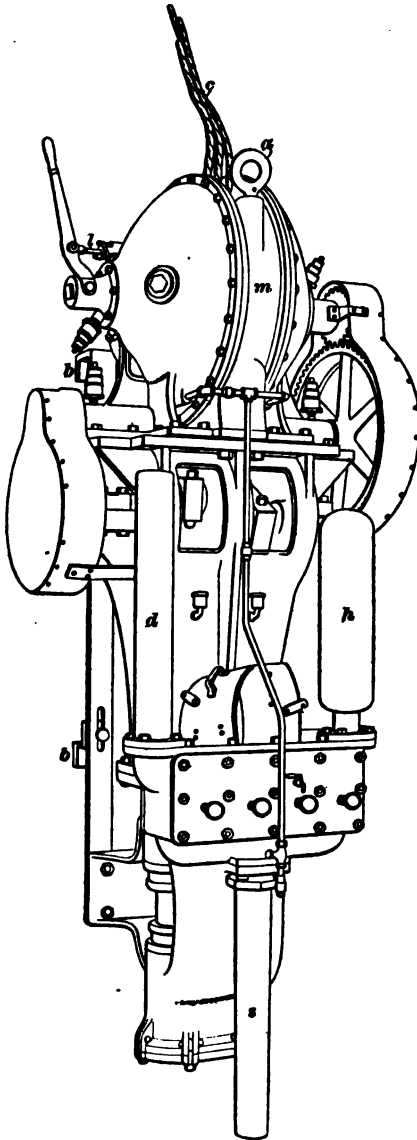

FIG. 6.

**16. Enclosed Sinking-Pump.**— Another electric mine sinking-pump is shown in Fig. 7. It is of the double-acting, outside-packed plunger type, and is protected against damage from water, moisture, and hard usage. The entire operating mechanism is enclosed in the case *c*, making it possible, with properly insulated cables, for the pump to work quite as well under water as above it. The motor, which is specially designed for the purpose, is further enclosed in a waterproof chamber, so that if anything should

happen to the outside casing *c*, the pump would still be capable of working when submerged. The only moving parts that are visible are portions of the piston *p* and plunger *q*, yet all wearing parts are easily accessible for repair. The pump is raised or lowered by a cable attached to the eye-bolt *e*, and it is fixed in place by engaging the supports *s* with suitable timbers in the shaft. An air-chamber *a* is placed on the water chest *w*, into which the pump discharges and out of which the water is forced to the surface

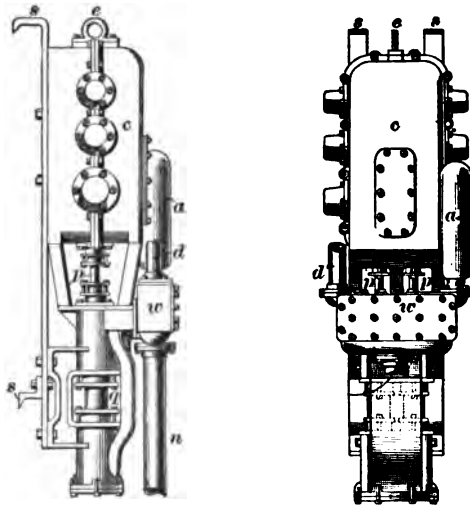

FIG. 7.

through the pipe *d*. The water is drawn from the sump at the bottom of the shaft through the suction-pipe *n*. One of these pumps with a 20-horsepower motor will discharge 250 gallons per minute at ordinary speed against a head of 100 feet. The plungers have a stroke of 8 inches and are  $6\frac{1}{2}$  inches in diameter, and the suction and discharge are 6 and 5 inches in diameter, respectively. The dimensions of the pump over all are  $30'' \times 45'' \times 114''$ , and its weight is 7,000 pounds,

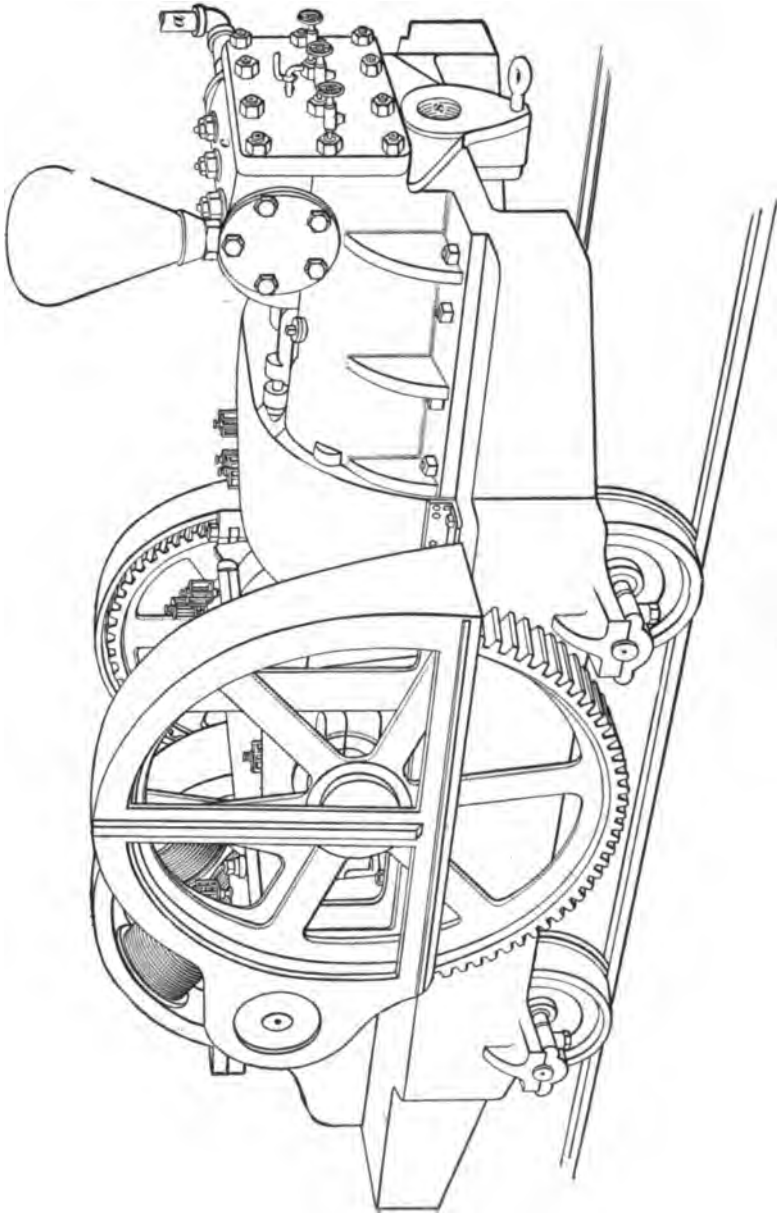

FIG. 8.

**17. Portable Pump.**—In some mines it is necessary to have auxiliary pumps to drain certain portions of the mine which are below the level of the main sump. For these local or auxiliary pumps, electric power is especially suitable. In driving wet dip headings, it is necessary to have some mechanical means of keeping the water away from the working-face. This is often accomplished by bailing the water into a water car and hauling it away, or by using hand-pumps. Both methods are expensive and often inefficient. With the use of electricity, however, such work can be done by the use of portable electric pumps, a horizontal triplex type of which is shown in Fig. 8. This pump is mounted on an iron truck, which can not be affected by moisture and which always maintains the accurate alinement of the pump and motor. The pump is made for a capacity of from 80 to 208 gallons per minute against a head of 300 feet. Such pumps require little attention, as they will not, if equipped with proper motors, run beyond a certain speed, even if working on air. Thus, if it is being used to drain the face of an entry passing a local dip, all the attention it will require will be an occasional oiling.

When in use, pumps of this type are generally switched off the main road into the neck of a room or breakthrough. The pipe leading to the sump at the working-face or to the body of water to be removed is connected to the pump at the opening *s* and the delivery-pipe to the opening at either side of the water chest *c*, as at *a*.

**18. Precautions.**—It is not wise to touch bare conductors carrying current at a pressure of over 110 volts, though serious harm is not apt to result from less than 300 volts if you are provided with gloves made of rubber or stand upon some dry insulating material. This fact should be remembered by persons traveling along headings where the conductors may be touched by some part of the body. A person wearing dry rubber boots or standing on dry wood may touch a single conductor through which a current is passing, without injury, provided he does not make contact

with the other side of the circuit with some exposed part of the body.

A dynamo or motor may become "charged" by injury to the wiring or by some loose coils touching the body of the machine. In such a case, it is exceedingly dangerous to touch any part of the machine, for it will discharge through the body into the earth. It is a wise precaution to connect the frames of pumps and other machines run by electricity to the earth, to prevent their inflicting possible injury to those handling them.

**19. Selection of Pump.**—In selecting the pump for any given duty, the first cost as well as the efficiency should be taken into account, as should also the location in which it is to be used. In some cases, especially in coal-mines, it is practically impossible to obtain headroom, and hence a low pump must be employed, while in some metal mines it is much easier to install a high machine than one that extends over considerable area. For this latter purpose, vertical duplex or triplex pumps driven by electric motors are frequently employed, especially where a comparatively small amount of water has to be handled. The simple fact that a pump is very efficient when it is one of a number driven by a carefully made generator of large capacity does not imply that it will be efficient for a small installation, and for this reason, if only one or two small pumps are required in the mine, it is generally much cheaper, both in first cost and in running expense, to install simply a boiler plant on the surface and use one or two steam-pumps underground, or to use compressed-air pumps and obtain air from the same system that drives the rock-drills. Then, too, the additional advantage of the improvement of the ventilation by the exhaust air from the pumps may have an important bearing upon the selection of compressed air as a motive power. As a general rule, it may be said that electric pumps should be used only where large installations are to be made, so that a number of small pumps or one or two large pumps may be supplied with power from a large generator driven by a very



efficient engine or where the current can be derived from generators driven by water-wheels. Another case in which electric pumps can be used to advantage is where the current can be obtained from some power company at an advantageous rate. This case really comes under the former, on account of the fact that a power company is able to furnish the power at a low figure, because it sells a great deal of it to its different customers, and hence large generators of high efficiency may be employed.

---

## ELECTRIC SIGNALING IN MINES.

---

### SIGNALING WITH BELLS.

**20.** A system of signaling is necessary in all mines having a shaft or slope or in which mechanical haulage is employed. The most primitive method used to any large extent is that of an iron or steel plate, which is struck by a hammer operated by a wire supported at intervals along the haulage road or in the shaft. The wire is pulled by a lever situated at either end of the haul or lift. This mechanical method, although in use in many mines today, is rapidly being replaced by electric systems of signaling, which are instantaneous and which best meet the various requirements of modern haulage and hoisting.

Electric signals are made by bells, lights, telephones, or a combination of these. The power for operating these signals is generally an electric battery consisting of a number of primary cells.

**21.** The different methods of placing the bells on the circuit are shown in Fig. 9. In Fig. 9 (*x*) three bells *a*, *b*, *c* are shown in series in the circuit. With this arrangement, it is impossible to get the makes and breaks at the different bells to properly synchronize, and the result is that the bells ring with a weak sound if all the bells are allowed to make and break the circuit. One method of overcoming this

difficulty is to cut out the make-and-break contact on all the bells but one, so that this one bell will be the only one interrupting the current in the circuit. The other bells will then be compelled to work in unison with the one doing the making and breaking of the circuit. Another method of overcoming this objection somewhat is by bridging the bells, so that a certain portion of the current will pass through them irrespective of the position of the hammers. This is shown in Fig. 9 (*y*), where the bells are put in parallel, and in order that each may ring with the same degree of sound,

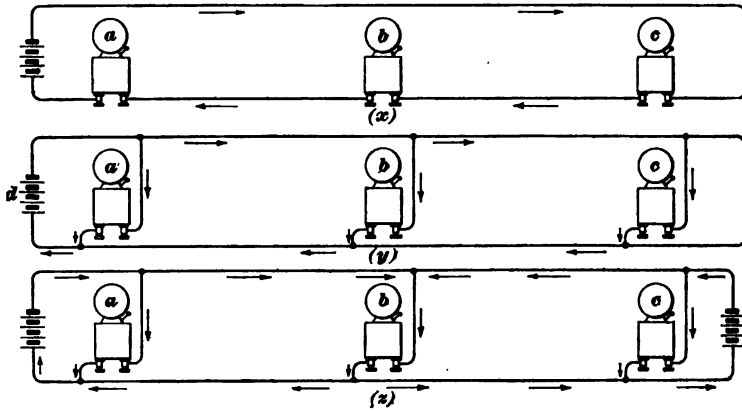

FIG. 9.

it is necessary that resistances should be put in series with each bell, except the one farthest away from the battery *d*. The resistances should be so arranged and proportioned as to cause the same current to flow through each bell. In the arrangement shown in Fig. 9 (*z*) there are two batteries forming two circuits that have a common path through the bell *b*. As a portion of the current from each battery passes through the bell *b*, which is the farthest away from the source of the power, it is seldom necessary to introduce resistance at the bells *a* and *c*.

**22.** It is well to have the bells placed in parallel for signaling in mines, as in this way the bells are not only

independent of each other, but can be supplied with more current from a given battery, and therefore are more reliable and work more satisfactorily than bells coupled up in series.

**23.** The method of obtaining the reciprocating motion of the bell hammer is shown in Fig. 10. A soft iron core is placed within a solenoid or coil of insulated wire, forming an electromagnet  $s$ , and an armature or piece of soft iron  $a$  is

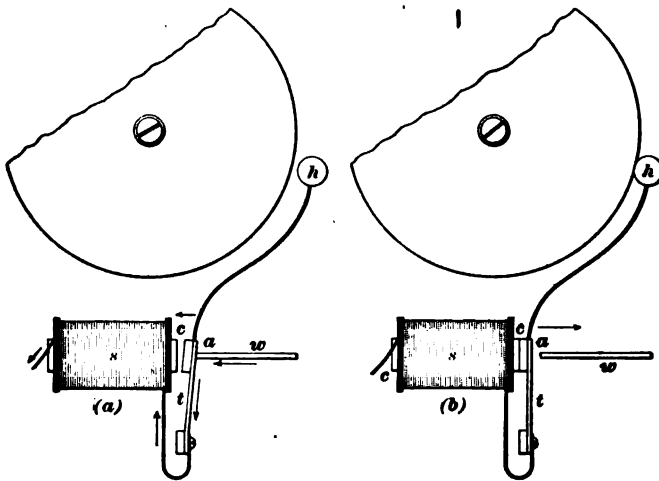

FIG. 10.

held between the end of the contact point  $w$  and the core  $c$  by means of a strip of steel, which acts as a spring. In (a) the current flows through the wire  $w$ , the spring  $t$ , thence into the solenoid  $s$ , and back to the battery. The core  $c$  becomes magnetized and attracts the armature to it. In doing so, however, the electric circuit is broken (b) and the core  $c$  loses its magnetism, allowing the spring to carry the armature  $a$  back till it rests against  $w$ , when magnetization recurs, and so on indefinitely, the hammer  $h$  striking the bell each time, and it is therefore caused to move in the same manner and strike the bell with a rapid succession of blows.

24. Fig. 11 shows an electric bell which has two electro-magnets *m* for the purpose of giving the core the approximate shape of a horseshoe magnet, whereby greater strength is obtained. The wire handle of the hammer *h* is attached to the upper end of the armature *a*. The adjustable contact screw *s* is tipped with platinum in order to prevent oxidation and burning from sparks during the makes and breaks of the circuit. The battery terminals are connected to the bell by the contact screws *t*, and the mechanism is placed in a box to keep out the dust and dirt.

The bell *b* and the hammer *h* which strikes it are, of course, not enclosed, and for this reason it is impossible to keep out dust entirely, consequently the box should be removed occasionally and the mechanism thoroughly cleaned.

The bells shown in Figs. 10 and 11 are of the vibrating or continuous-ringing type; i. e., so long as the bell is connected to the battery by depressing the push-button it will continue to ring. For some purposes, it is desirable to use **single-stroke** bells, which will give only one ring when the push is depressed. All that is necessary to convert a vibrating bell into a single-stroke bell is to connect the terminals of the magnet coil directly to the binding-posts of the bell, so that the current does not have to pass through the armature and contact points. When this is done, the magnet holds the armature so long as the push remains depressed, and each time the push is pressed the bell gives one stroke, thus making it specially applicable for signaling purposes.

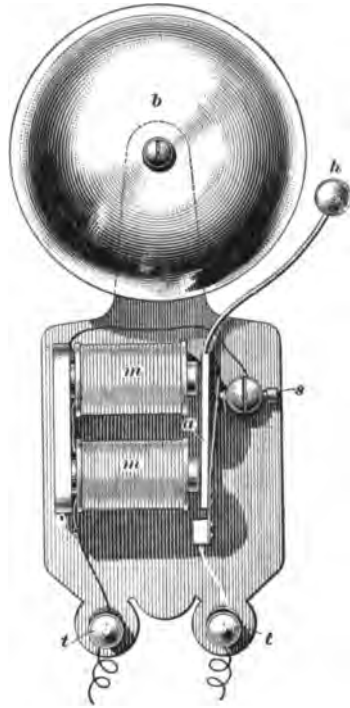

FIG. 11.

25. It is necessary to have circuit-closers, or **push-buttons**, as they are called, at different points in an electric-signal system.

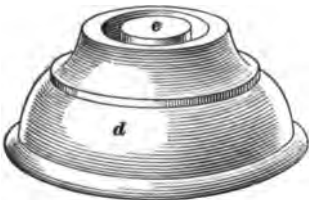
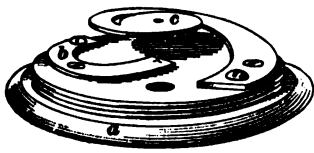

FIG. 12.

One form of push-button is illustrated in Fig. 12. The ends of the line-wire are brought up through a hole in the wooden base *a* and held under the screws on the brass contact springs *b*, *c*. The cap *d* when screwed in place holds the button *e*, which on being pressed down forces the two springs together and completes the circuit, causing the bell to ring. This type of push-button is operated

by a single finger, and is not frequently employed for inside

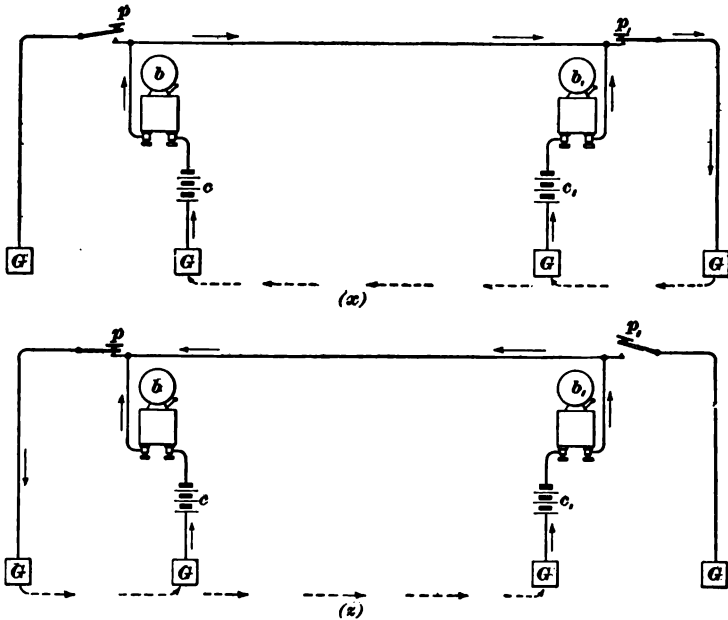

FIG. 13.

mine work. For this latter purpose, a larger type, which can be operated by the palm of the hand, is used.

**26. Signal With Ground-Connection.**—The construction of a circuit showing the relative positions of the batteries  $c, c_1$ , bells  $b, b_1$ , and push-buttons  $p, p_1$  is shown in Fig. 13. The object of this arrangement is to allow the current from either battery to pass to the earth and have a complete circuit when either of the push-buttons is pressed down, while but one line-wire is used. The top view ( $x$ ) shows the behavior of the current when the button  $p_1$  is pressed down, and the bottom view ( $z$ ) when the circuit is completed at the button  $p$ . The batteries should be connected with like poles to ground.

**27. Signal Without Ground-Connection.**—Where earth connections are poor, a return wire is used, as shown

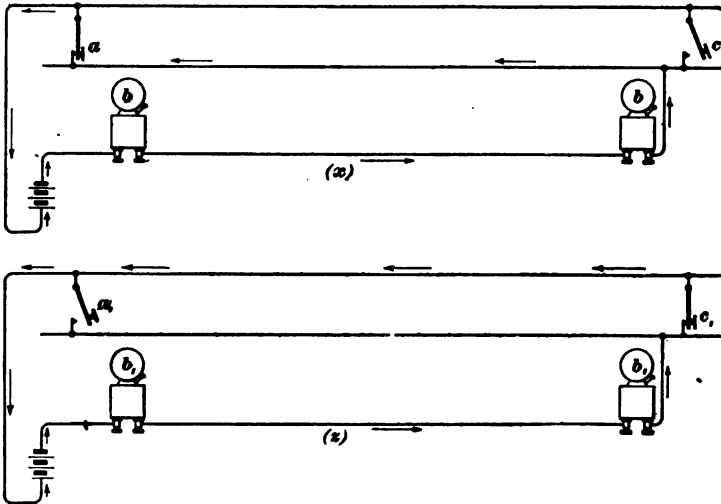

FIG. 14.

in Fig. 14. The bells  $b, b$  are in series, and in order to prevent both push-buttons from being on the same circuit, a third wire is necessary. In the top view ( $x$ ) the button  $a$  is closed, leaving the top wire neutral, while in the bottom view ( $z$ ) the button  $c$  is closed, leaving the center wire neutral. The object of having both bells ring when a signal is sent from either end is to assure the sender that everything is all right

when he presses the button and the bell next him rings. On the other hand, if the bell does not ring he knows the signal has not been sent and that something is wrong.

**28. Signals for Haulage Roads.**—On haulage roads it is necessary to provide a system of signaling by which the trip rider can have the trip of cars stopped or started at any point. Such a system is shown in Fig. 15. Here two batteries  $c, c_1$  and four ground-connections  $G$  are used. With the exception of the top wire, this system is the same as that shown in Fig. 13, and signals from either end of the line are given in exactly the same manner. The two wires which run along the roadside are only 6 or 8 inches apart and parallel to each other. The trip rider carries a short piece of

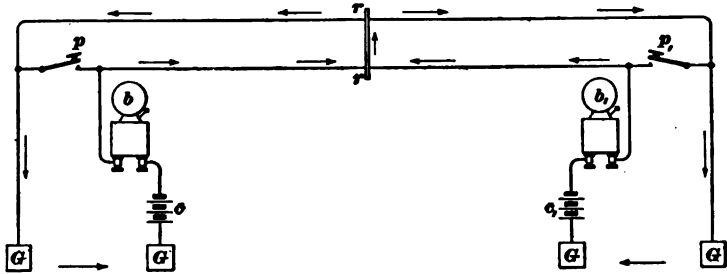

FIG. 15.

iron, which he places across the wires at any point where he desires to signal the engineer to either stop or start the trip. The iron  $r$  is shown in contact with the wires, and from the flow of the currents, which is indicated by the arrows, it can be seen that both bells  $b, b_1$  will ring. With this arrangement, it is not only possible to signal to stop or start the trip from any point, but also to signal to either end of the road for assistance in case of accident. It often happens that the trip rider while on a car that has been derailed must signal to the engineer to stop the trip. This he quickly does by reaching out and striking the wires with the iron which he holds in his hand. Thus it is seen how necessary it is to have the wires within the reach of the trip rider while on the moving trip. Two rings are generally used to

start, and three to back up. Any other numbers may be used for other signals which may be found necessary for the safe and rapid operation of the haulage system in use.

**29.** The arrangement shown in Fig. 16 is the same as that shown in Fig. 15, except that the top wires are placed

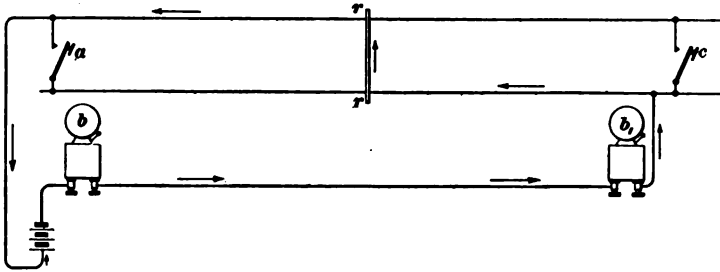

FIG. 16.

near and parallel to each other, so that contact can be made between them with the ringer or iron bar *r r*. This arrangement fulfils the same requirements as that shown in Fig. 15, but the bells are in series instead of being on independent circuits, and only one battery is used.

**30.** Where signals must be received from different parts of the mine, as, for instance, at the junction of several haulage roads where the engine is placed, the method of having a code for each road requires a great many rings, and is likely to confuse the engineer and cause accidents. Again, it is quite as unsatisfactory to have the same code for all the roads and bells that have different sounds, because it is difficult to construct bells whose sounds are so distinctively

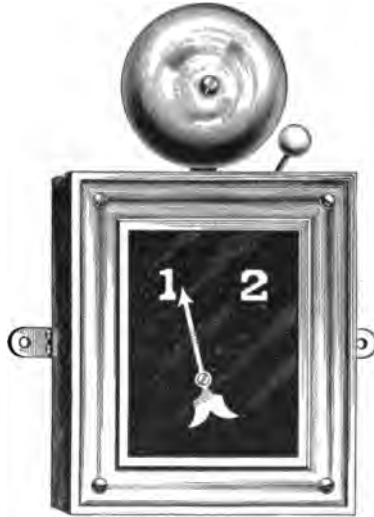

FIG. 17.



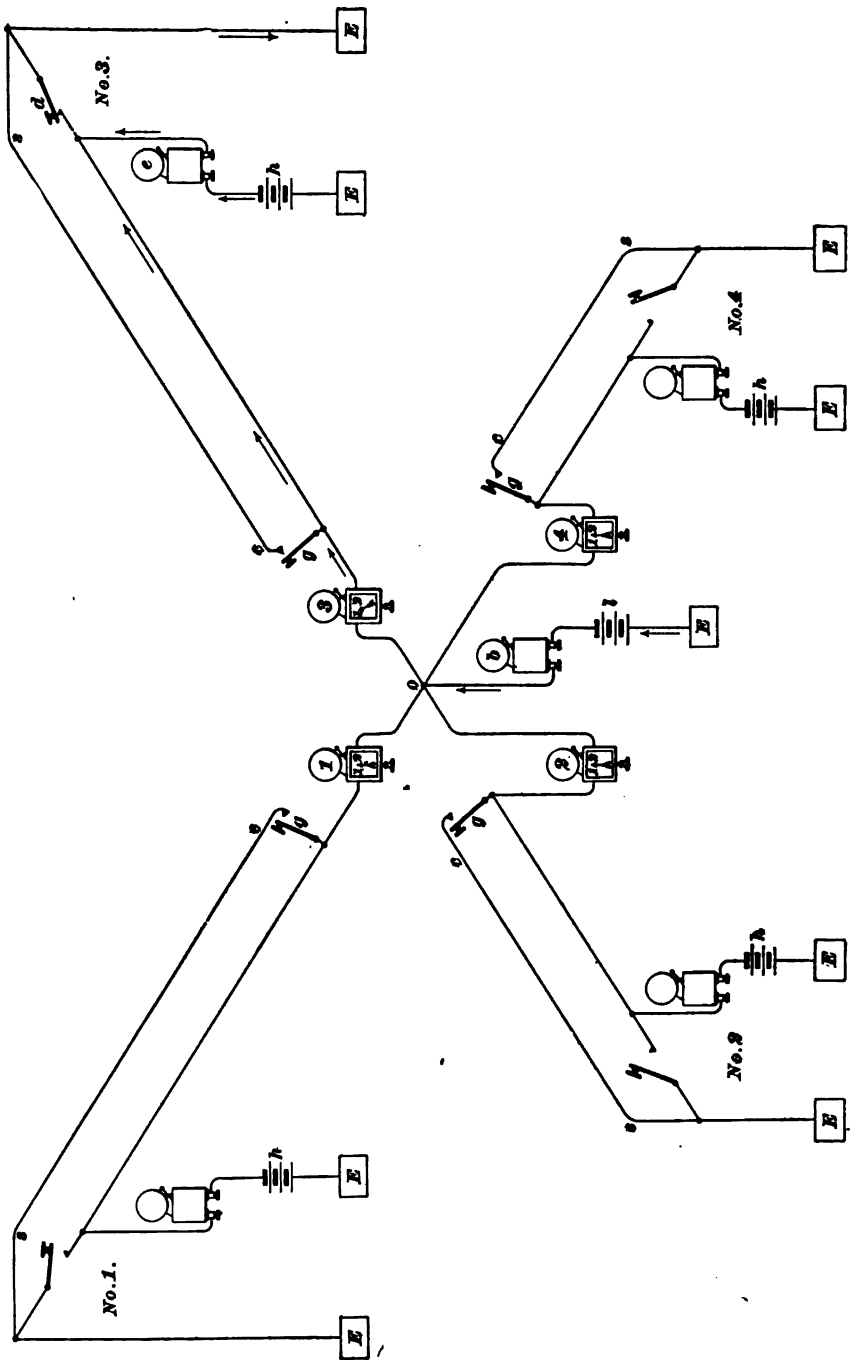

FIG. 18.

different that no confusion or mistake will happen. These difficulties are largely overcome by the use of a signal code and an annunciator, Fig. 17. This annunciator is provided with a bell, the particular one shown indicating two places only. Where a signal has been given, the engineer can see immediately from which haulage road it has been sent by the pointer on the annunciator.

**31.** Fig. 18 shows in principle the arrangement of a system of signaling at the junction of four haulage roads. It is designed to avoid confusion on the part of the engineer, and thereby prevent accident or delay. The positive wires from the batteries *k* and the annunciator battery *l* all unite at *o*, and each is connected to the operating mechanism of a pointer on the annunciator. By the use of batteries at the end of the haulage road, a bell can be rung when the push-button is closed. This insures the sender that the signal has been given to the engineer. The wire *cs* makes it possible for a signal to be given by the trip rider at any point on the haulage road.

The figure shows the condition which exists when the push-button *d* at the end of *No. 3* entry is closed. From the direction of the current, which is shown by the arrows, it will be seen that the bells *e* and *b* will both ring, and that the pointer *s* will be deflected, showing the engineer from which road the signal has been sent. The instant the current ceases the pointer assumes its vertical position. It is, however, often advisable to have the pointer remain in its deflected position, for the engineer may be engaged in oiling or repairing his engine and be unable to see the annunciator at the moment the bell rings. In this case, it is necessary to have a convenient mechanical or electric method of allowing the pointers to assume their position whenever the engineer has seen the annunciator and operated the releasing apparatus.

In case a double call is received from different entries at the same time, the pointer will indicate it, and in order that the engineer will be sure of the proper number of rings from

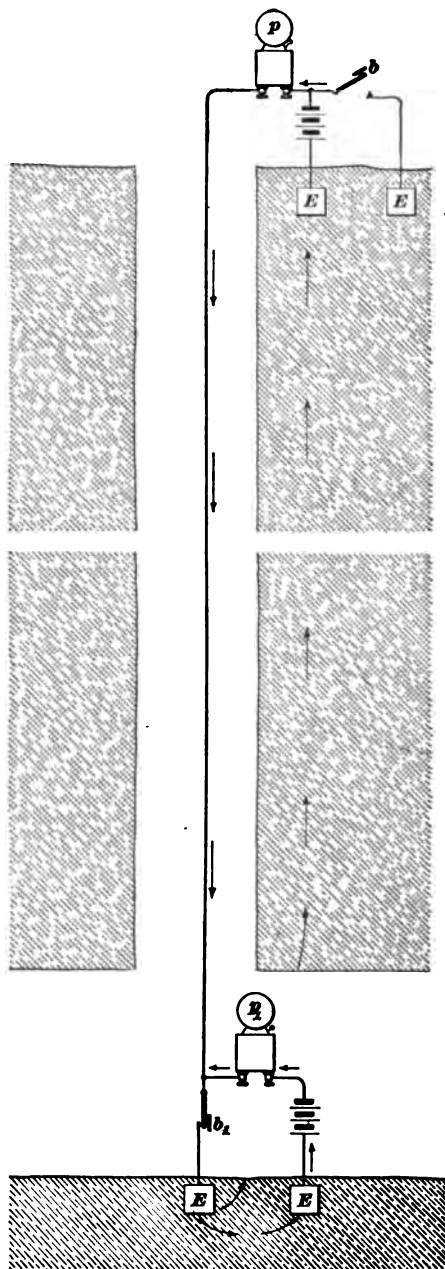

FIG. 19.

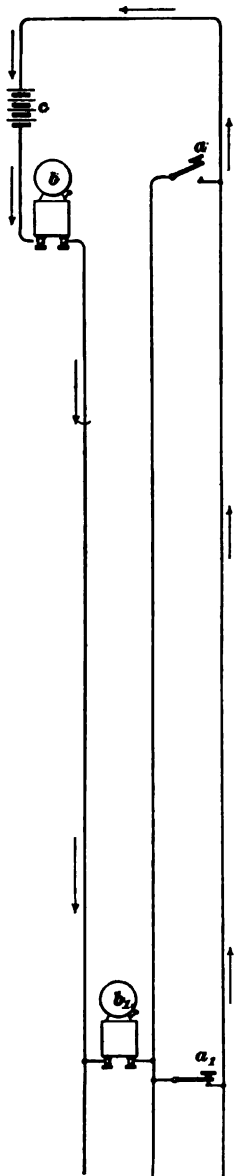

FIG. 20.

any one station, he must wait until he gets a complete signal in which but one pointer has been deflected. It is often necessary for the engineer to signal to the inside stations. This is accomplished by means of the push-buttons  $g$  which are placed on the different lines. It may be convenient to have the grades of the respective haulage roads roughly represented by broken lines on the annunciator. When this is done, each line is placed to one side of the corresponding pointer, so that the instant a signal is given the engineer can see the grades over which the trip must be hauled, and therefore be more likely to handle the engine in the best manner.

**32. Signals in Shafts.**—The method of signaling in shafts is quite similar to that used on haulage roads. Fig. 19 shows in principle the arrangement of a signaling system in a shaft. The positive wire passing down the shaft is well insulated and run through a small pipe for protection. The push-button  $b_1$  is closed, and from the flow of the current it will be seen that both bells will ring. The operation of this arrangement can readily be understood from what has previously been said.

**33.** In order that the cage may be stopped at any point in the shaft where repairing of any kind is required, it is necessary to have a system of signaling from the cage to the engine room. There are a number of ways of

accomplishing this, but the usual method is that in which trolleys are used. Two wires pass from the battery down the shaft, and they are supported at intervals with ordinary hangers. A trolley runs on each, in a manner like that of a street-car or an electric locomotive trolley. In this way current can be carried to the bell or telephone on the cage and signals given to the engineer by a man in the moving cage.

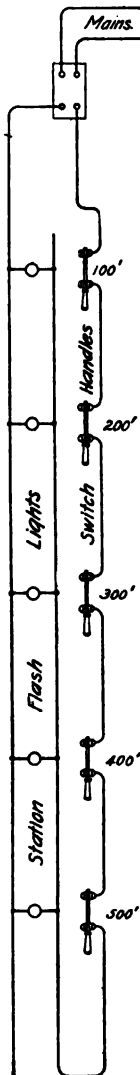

FIG. 21.

**34.** Fig. 20 shows another method of signaling in a shaft or slope. When signaling from intermediate points by this method, it is necessary to connect the middle wire and the wire  $a, a_1$  by a ringer, precisely as is done in haulage systems. The bells  $b, b_1$ , placed at the top and bottom of the shaft, are in series and always ring, no matter where the signal may be given. But one battery  $c$  is used. The push-button  $a_1$  is closed and the current is flowing in the outside wires, leaving, in this case, the center wire neutral. With this system, a telephone can not be used on the cage, nor is it an easy matter to send a signal from the cage when it is moving rapidly.

#### MISCELLANEOUS METHODS OF SIGNALING.

##### **35. Signaling by Flash-Lights.—**

Fig. 21 shows a method of signaling by means of flash-lights, which is used in the Western States. It consists of a switch "cut in" to the main circuit at the different levels. When any switch is thrown out and in, a flash is produced in all the lamps on the circuit. If the cage is required at any level, the signal corresponding to that level can be given to the station tender, no matter what level he may be at, and he in turn will give the signal to the engineer.

This system is very simple and reliable. It has replaced largely the old-fashioned bell-rope and the electric bells and batteries, which give considerable trouble in deep, wet shafts. If lights are inserted in the circuit at different parts of the mine, the signals will be flashed throughout the mine, and in case it is necessary to signal to the various parts of the mine that an accident has occurred, it can easily and quickly be done from any switch. This is usually done by giving the accident signal, and then following it by the signal of the level on which the accident has occurred.

**36. Signal System With Telephones.**—A system of signaling in which the telephone supplements the bells and push-buttons is shown in Fig. 22. A high-grade bridging telephone is used, because loose contact in any telephone on the circuit does not affect the working of the others, and any defect in contact can be readily located and quickly fixed. The bells are of the skeleton-frame type with pivoted armatures. They are wound for different resistances, depending upon the work they have to do. When the circuits are well insulated, the ordinary open-circuit carbon-cylinder battery is used, because it is quite strong and easily and cheaply recharged. For circuits poorly insulated on account of water and grounds, the Gordon, Edison-Lalande, or similar type of battery is employed, because it does not polarize when the line is badly grounded and is less expensive to operate under such conditions than the ordinary open-circuit battery. On leaky circuits the Gordon batteries have worked for nearly two years without recharging, while the carbon batteries on the same circuits had to be recharged about every ten days.

**37.** The figure illustrates the arrangement of the signals at seven landings in a shaft. Each landing has a separate call to the engine room, which rings a bell at the same time at the head of the shaft. There is a separate call between the engineer and the head tender at the head of the shaft. A telephone is placed in the engine room and one at each landing in the shaft. The wires

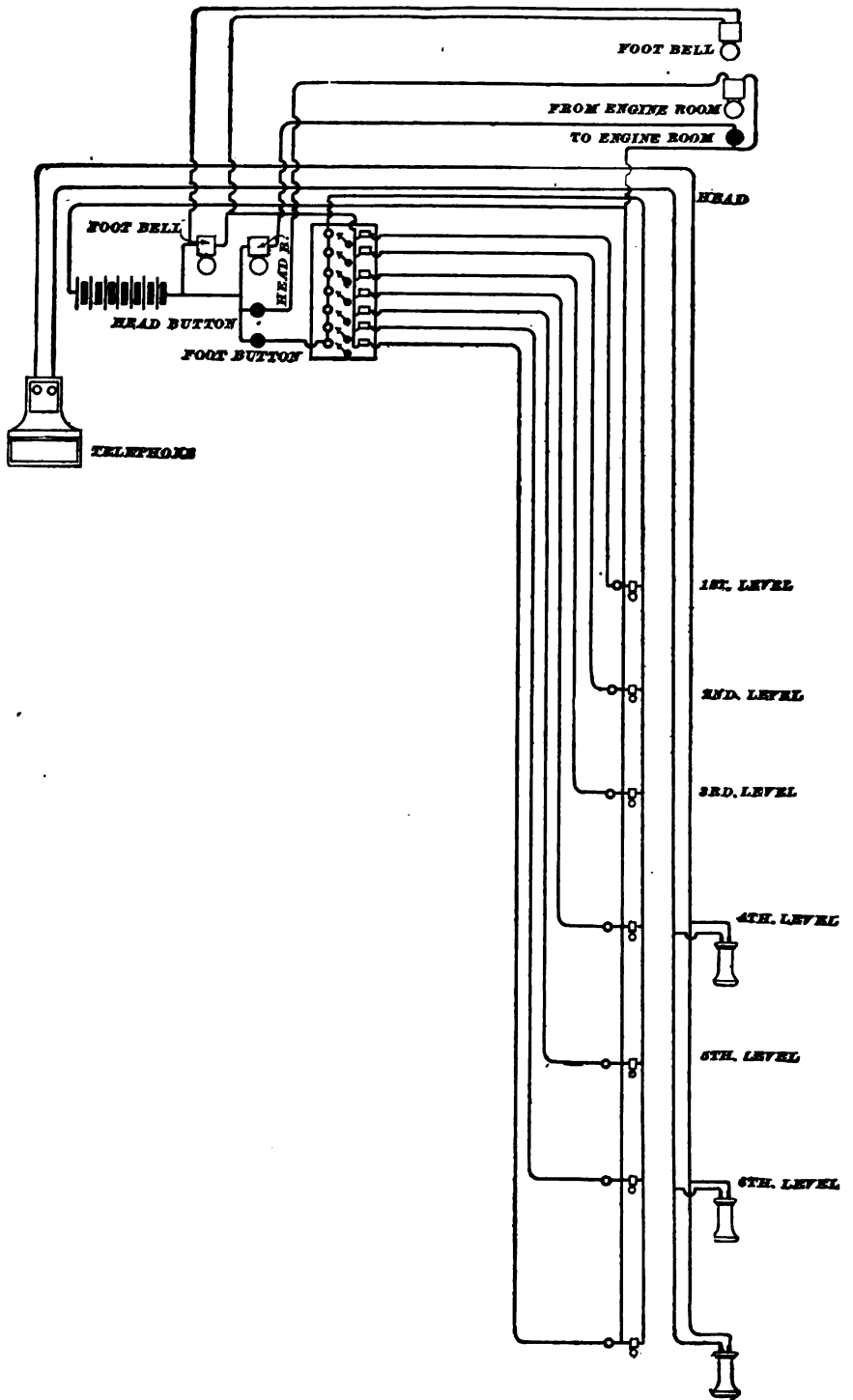

FIG. 22.

from the engine room to the shaft head and to the landings in the shaft are arranged in cables containing one No. 14 copper wire and as many No. 18 copper wires as are required. Each wire is insulated with paper and the wires properly stranded into a cable, which is well soaked in paraffin, wrapped with cotton, and then covered with lead  $\frac{3}{8}$  inch thick, to make it waterproof. A layer of jute soaked in asphalt is laid over the lead, and the whole covered with a layer of No. 10 galvanized-iron wire armoring. That portion of the cable leading from the head of the shaft to the engineer's platform is carried through a 2-inch iron pipe. The end of the pipe at the head of the shaft terminates in a heavy oak box, and here the wires of the cable are separated and conducted to their proper places.

**38.** The telephones in the mine are each placed in a large wooden box and located in a dry spot, generally about 15 feet from the shaft. The box has a hinged door on front, with a small opening in it, opposite the telephone bells, and covered with a wire screen, so that the foot tender can hear the bell with the door closed. The return bell is fastened to the outside of the telephone box, which acts as a sounding-board, and the wires are brought out through the wood at the binding-posts of the bell. By this method the only wires exposed are at the terminals of the bells and buttons, and these are thoroughly taped. Heavy rubber-covered wire is used to make the connections between the cables and the bells and buttons and telephones.

To facilitate repairs, the wires in each junction-box are each designated by a thin copper tag giving the name of the wire. The No. 14 wire in each cable is the main-battery wire, and may be readily picked out by its size. This large wire lowers the resistance of each circuit, and it is the common-battery wire for all the call and reply circuits. The circuits are arranged as shown in the figure.

The main-battery wire runs to the bottom of shaft, and from it the button wires are tapped off at each landing, the current returning from the button by a separate wire to the



annunciator in the engine room and onwards to the shaft bells, one being at the head of the shaft and the other at the annunciator.

The reply bells are connected by the main-battery wire in multiple to a common-return wire at the reply side of the annunciator.

Between the engineer and head tender there is a call-and-reply connection, as shown. The wires from the junction-box at the head of the shaft are arranged with the bells and buttons in the same way as for the other outlets.

**39.** The distinctive feature of this system is the annunciator, which indicates for 7 points that lie in a vertical line, and are named for the different veins they represent. Each point is located between two magnets, one wound for the call and the other for the reply from the engineer. The magnets in the reply circuit are connected in series, so that when the circuit is closed by the engineer, the current passes through all the magnets, throwing all the drops up to the "off" position and ringing all the reply bells on the line. The engineer can not throw up the drops except by ringing the reply bells, as the annunciator is completely enclosed.

All the bells are wound for 20 ohms resistance. The two bells in the engine room, besides being separated about 10 feet, are of entirely different sound, so that there is no possibility of any mistake about the rings. The bells at the head of the shaft are arranged in the same manner, one being the ordinary gong and the other a bell of the hand type.

The battery is located in a cupboard on the wall of the engine room, and the wires are carried from it to the rack in an iron pipe. It consists of 18 cells of a carbon-cylinder battery in series, and a space is left at the end of the box to receive the extra telephone wires that are used to connect the two shafts.

**40.** In the shaft, the foot tender has charge of all the inside bells, and no one is allowed to ring them without his consent. If he is working at a landing and any men wish

to go up or down from another landing, they are required to call upon the telephone, and when the footman is ready he goes to that landing and sends the men to their destination, always staying in charge of the signals.

Should any one ring from one landing while the footman is working at another, the engineer can tell immediately by the annunciator that it was not the footman, and can see just where the ring has come from.

The telephone is used, however, as it is more satisfactory and safer, and does not cause any confusion in the signals.

The button wires for the engineer are run out through a small iron pipe from the rack to a convenient point for the engineer, and on the ends of these is fastened a plate on which are placed the two push-buttons for the engineer's use.

**41. Haulage Block Signal.**—A good system of signaling on a haulage road, common to two or more roads and used by several locomotives, is shown in Fig. 23. A switch

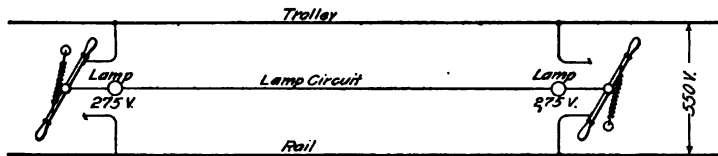

FIG. 23.

with a double-handle single-hinged lever is placed at either end of the road; one terminal of each switch is connected with the trolley-wire and the other with the rail, the center of the levers being connected by a wire, in which a lamp is inserted near each switch as shown. A spring is so attached to each lever that it will insure good contact for either position of the lever. Clear lights are used for clear tracks and darkness for occupied track. As one or the other of the ends of each lever is always in contact, a motorman approaching either end of the road can cut out the lamps by throwing the lever in the required direction to change the contact, and when he reaches the other end, he can change the contact again by throwing the lever of the other switch,

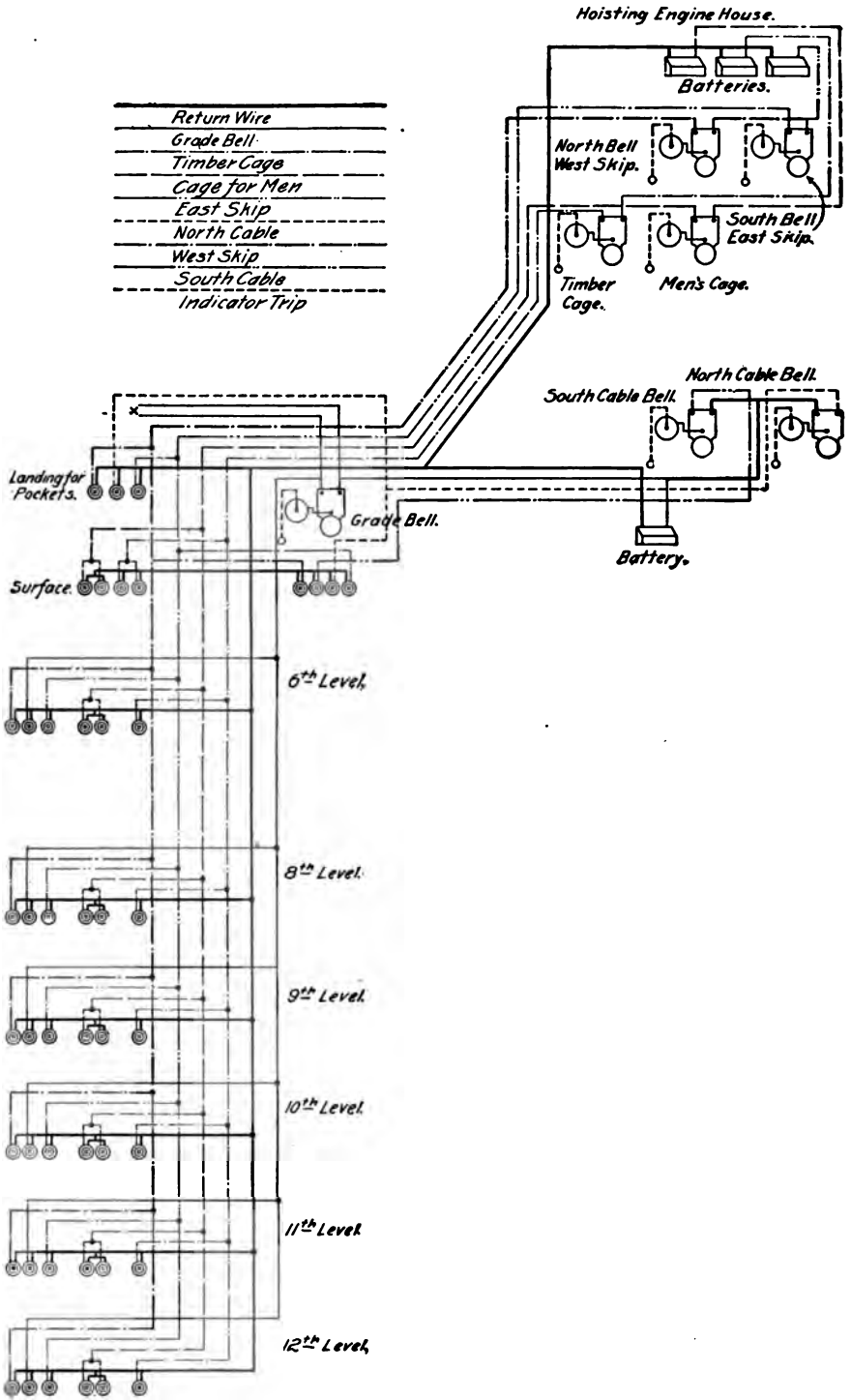

FIG. 24.

which cuts in the lamps again. The switches may be placed at any convenient place on the rib side or the roof, so that the motorman can operate the levers while the motor is going at full speed.

**42. Special Shaft-Signal System.**—As an example of wiring to cover the various requirements at a somewhat complicated shaft, Fig. 24 is given. The grade bell is intended for signaling the grade of ore to be hoisted, so as to facilitate the placing of it in its proper bin or pocket. The cable bells are intended for controlling the cables which operate the surface haulage plant at the shaft, while the other bells are employed in connection with the signals for the timber cage, the men's cage, and the ore skips. This system is in use at the West Vulcan mine in the Lake Superior region.

**43.** Six strands of wire are used in the shaft, as shown in Fig. 24. Five act as main wires and one as a return wire. The six wires are tied together every 5 feet, forming a cable. This is passed down through an iron pipe. The pipe is made tight by a tapered wooden plug, which is split and grooved to allow spaces for six wires. The plug is driven into the pipe and resin melted and run into the groove around the wires, sealing the wires in the pipe. To make sure that the wires will not draw through, a clamp is put on them above the plug. At each level the wires are brought out through a T in the pipe to connect with the buttons; then they are passed back through the T again and dropped to the next level below. After passing the wires back into the pipe, a plug similar to the one previously mentioned is inserted in the T and the wires sealed and clamped.

All connections are soldered, using the best blowpipe solder and powdered resin. After the connection is soldered, it is insulated with okonite tape and a heavy coat of Stockholm tar applied. Then a tight-fitting piece of rubber tubing about 4 inches long is slipped over the joint and bound at each end with a small copper wire. The connections made in this way have stood for the last four months

and are in first-class condition. In the shaft house and the stations, for extra protection, a box-casing, painted inside and out, large enough for 12 wires, is used. As soon as the wires are put in, the cover, which fits snugly, is painted and driven into place, making the joints water-tight. This puts the wires out of harm's way and makes a neat appearance.

Fig. 24 shows the system of wiring, which includes seven main wires, on which are 47 buttons, and one return wire. The main wires each have an 8-inch single-stroke bell with indicator attached, and are operated by four batteries. Two of the main wires run only from the shaft house to the cable-engine house. The different wires are indicated as shown in the figure.

**44.** Owing to the fact that the shaft was very wet, special wooden casings had to be constructed for the protection of the push-button.

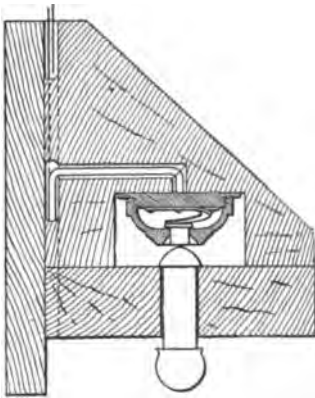

FIG. 25.

In these cases, the button was so arranged that the plunger was pressed up against the button from below, as shown in Fig. 25. This rendered the casing self-draining and thoroughly protected it from moisture.

**45.** The heavy black line represents the return wire, which is connected to the negative pole of each battery and all the bells and buttons.

The main wire for the grade bell has a button on each level. By following the main wire from the positive pole of the battery in the cable-engine house to the grade bell in the shaft house, thence to one of the buttons in the mine, thence by the return wire to the negative pole, it will be seen that the grade bell will ring if any button on this line is pushed. The main wire for the timber-cage bell, which is in the hoisting-engine house, is shown as indicated. On

the men's-cage wire there are two buttons at each station, one of which can be rung from the cage. The east-skip main wire and the west-skip main wire are also indicated. One battery is sufficient for these two lines, as the skips are run in balance and only one bell is rung at a time. The main wire for the south cable-engine bell is shown. One battery answers for the grade bell and both cable-engine bells, as they are never rung together. When the system was first put in, there were only two batteries, one in each engine house on the return wire. The result of putting the battery on the return wire is that if a button is pushed on two or more lines at a time, the electromotive force on each will be much less than when one line is in use, and the bells will not ring properly. If the batteries are distributed, the chance of all the lines giving out at once is practically eliminated.

The indicator was designed by Mr. E. Roberts, master mechanic of the Penn Iron Mining Company. The hand of the indicator is revolved by a ratchet connected by a rod to the armature of the bell. The case and hand are the same as used for steam-gauges, and the face is a clock dial. The hand stops when it reaches 11 and may be brought back to 0 by pulling a cord. It is adjusted to register if the armature makes a quarter of its stroke. The object of the indicator is to enable the men to see as well as hear the signal.

---

## ELECTRIC LIGHTING IN MINES.

---

**46.** Where electricity is used in mining, it is generally found advantageous to use a portion of the current for lighting, both in the surface plant and the underground workings. The light is brighter than that given by the miner's oil lamp or candle, it has no exposed flame to set fire to mine gas, requires little or no attention, and can not be blown out by draft. Of course, it is not portable to the same extent as a candle or oil lamp, and is, therefore, not generally used at the working-face, but for landings, main gangways, turnouts, and where machines are located, it is very useful.

### INCANDESCENT LAMPS.

**47. The Incandescent Lamp.**—Incandescent lamps give approximately the equivalent in light of one standard candle for every  $3\frac{1}{4}$  to 4 watts consumed. As there are 746 watts in a horsepower, this means over 200 candle-power per horsepower expended. The lamp most commonly employed is of 16 candle-power, but they are made in various sizes up to 100 candle-power. The light emitted by the incandescent lamp is due to the heating of a fine filament or thread of carbonized vegetable substance by the passage of the electric current. The filament is enclosed in a bulb from which the air has been exhausted to a high degree to prevent rapid oxidation.

**48. Voltage of Lamps.**—Incandescent lamps are nearly always operated in parallel, i. e., connected directly

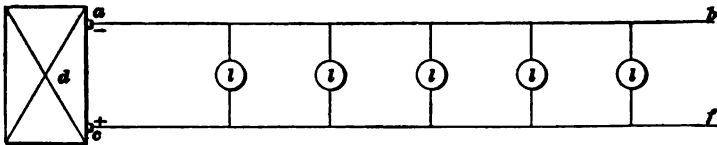

FIG. 26.

across the mains *b, f*, as shown in Fig. 26. The pressure maintained by the dynamo *d* is constant, no matter how many lights may be in operation, and as the lights *l* are turned on, the current delivered by the dynamo increases.

TABLE I.

Volts.	Candle-power.	Amperes.
52	16	1.0
52	32	2.0
52	100	6.0
110	16	.5
110	32	1.0
110	100	3.0

The pressure maintained between the lines is usually in the neighborhood of 100 volts. The usual voltage employed when lamps are operated on direct-current circuits is 110 volts. The current required for the operation of incandescent lamps of the sizes and voltages commonly met with is about as given in Table I.

The current required will vary according to the make of the lamp, as some lamps give more light per watt expended than others. About 3.5 watts per candle-power is a fair average, hence the current taken by a lamp may be obtained approximately from the formula

$$c = \frac{\text{c. p.} \times 3.5}{E}, \quad (1.)$$

where  $E$  is the voltage at which the lamp is operated. The values given in the table are those generally employed in making calculations for lines supplying incandescent lamps.

### ARC LAMPS.

**49. Open-Arc Lamps.**—Arc lamps are extensively used for outdoor lighting or in places where very large areas are to be illuminated—as, for example, around the entrance to shafts, etc. Fig. 27 shows the appearance of an ordinary arc. The carbon rods  $A$ ,  $B$  are first touched together and then separated a short distance.  $A$  is connected to the positive pole of a dynamo and  $B$  to the negative, and when the carbons are separated, the current passes between them, forming the “arc.” This causes the carbon-points to become heated to a very high temperature, and when direct current is used, the upper or positive carbon becomes much hotter than the lower. The lower carbon becomes pointed and the upper one has a small hollow, known as the *crater*, formed in its tip. This crater

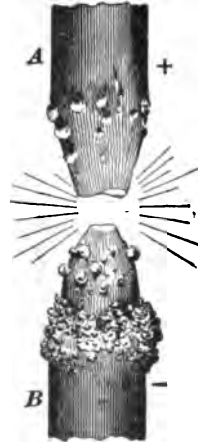

FIG. 27.



is the seat of the greater part of the light, and on this account the lamp throws the most intense illumination downwards at an angle of about  $45^\circ$ . When arc lamps are operated on alternating current, both carbons become pointed more nearly alike, and the light is thrown up more. On this account, alternating-current arc lamps should be provided with reflectors. Care should be taken in connecting up direct-current arc lamps to see that the upper carbon is connected to the positive side of the line, otherwise the lamp will burn "upside down," i. e., the crater will be formed in the lower carbon and the light thrown upwards. By allowing a lamp to burn for a short time, one can easily tell as to whether it is connected up correctly by noting the

shape of the points. The lower carbon is nearly always fixed and the upper carbon fed down by means of a clutch or clockwork mechanism controlled by an electromagnet. These lamps are termed open-arc lamps, in order to distinguish them from the later style of enclosed-arc lamp, where the arc is enclosed in a small globe instead of being open to the air. An ordinary arc lamp of 1,200 nominal candle-power requires about 300 watts for its operation. A 2,000 nominal candle-power lamp requires about 450 watts, and the current is usually from 6.8 to 10 amperes. The ordinary 2,000 candle-power arc lamp requires a pressure of about 45 or 50 volts across its terminals in order to secure satisfactory operation.

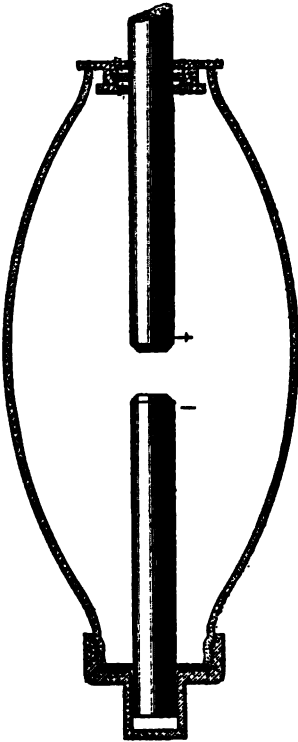

FIG. 23.

**50. Enclosed-Arc Lamps.**—In this style of lamp the arc is

enclosed in a glass bulb, as shown in Fig. 28. The enclosed-arc lamp is coming very largely into use, because it gives a fine, steady light and the carbons are consumed at a very slow rate, on account of their being enclosed in a space where very little oxygen is present. As soon as the arc is started, the oxygen present in the enclosing globe is soon burnt out, and the gases become so heated that they expand and pass out through the top around the upper carbon rod, as the rod does not, of course, fit air-tight. The result is that the arc burns in a partial vacuum, and the rate of consumption is so slow that a lamp will burn 150 hours without retrimming. An ordinary arc lamp will only burn about 10 hours before new carbons are required. For enclosed-arc lamps a very high grade of carbon must be used, so that the decreased cost of trimming is offset to a slight extent by the increased cost of the carbons. These lamps take a smaller current (from 3 to 6.6 amperes) than the open arcs, and require a correspondingly higher voltage (from 75 to 85 volts across the arc). They burn with a long arc, because it is necessary to have the carbons separated considerably, in order to allow the light to be thrown out properly. The carbons burn with flat ends, and do not become pointed, as in the open arc.

---

## LIGHTING SYSTEMS.

---

### INCANDESCENT LIGHTING BY DIRECT CURRENT.

**51.** Most of the incandescent lamps used in mines are operated by means of direct current. Very often the lamps are run in connection with the mine-haulage or pumping system and are operated from the same dynamo. It is better practice, where possible, not to operate lamps on a mine-haulage system, because one side (the track) of such a system is always grounded, and if lamps are run on such circuits there is always danger of getting shocks. There is

also more danger of fire, due to defective insulation, than if the lamps run on a circuit, both sides of which are insulated—as, for example, a regular power or lighting circuit.

**52.** As stated in Art. 48, incandescent lamps are commonly connected in parallel, as shown in Fig. 26. If one lamp is put out, the others are not affected. For haulage or power circuits, the pressure used is usually 250 or 500 volts. If an ordinary 110-volt lamp were connected across such circuits, it would be at once burnt out; hence on 250-volt circuits, we must use two 125-volt lamps connected in series, as shown in Fig. 29. This is known as the **multiple-series** system. When 500 volts is used, five lamps would be

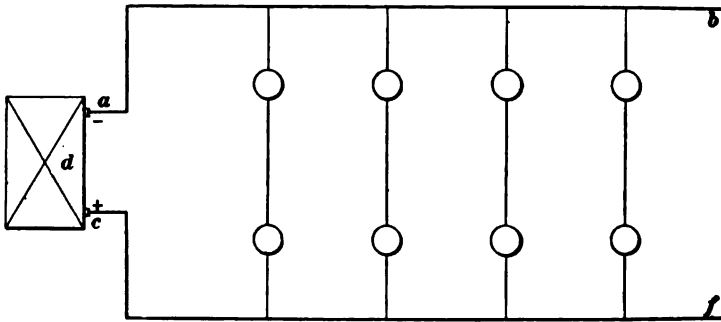

FIG. 29.

connected in series across the lines. Of course in the multiple-series system, when one lamp burns out, it puts out the others in series with it. With the lamps in multiple, as in Fig. 26, there will be  $\frac{1}{2}$  ampere delivered over the line for each 16 c. p. lamp connected. With two lamps in series, there will be  $\frac{1}{4}$  ampere in the line for each 16 c. p. lamp, or  $\frac{1}{2}$  ampere for each pair of lamps, and with five lamps in series, there will be  $\frac{1}{10}$  ampere per lamp, or  $\frac{1}{2}$  ampere for each group of five lamps. These current allowances per lamp will be found useful in estimating the size of wire necessary to carry current to a number of lamps.

**INCANDESCENT LIGHTING WITH ALTERNATING CURRENT.**

53. Where lights are widely scattered or where it is a long distance from the dynamo to the point where the light is used, alternating current is employed, because this current can be generated at high pressure and transmitted over the line to a point near where it is to be utilized. The pressure is then lowered by means of transformers to a pressure suited to the lamps and the local distribution carried out at low pressure. This arrangement is shown in Fig. 30, where

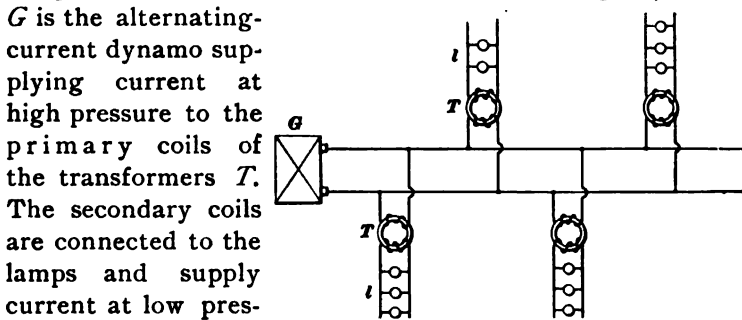

FIG. 30.

The pressure generated by the dynamo is usually 1,000 or 2,000 volts, and on account of this high pressure, the primary wires should not be carried anywhere in the mine where there is any liability of their being a source of danger. The best plan is to carry the primary wires to **substations**, where the transformers are placed and where there will be no danger from the high E. M. F. The current may then be distributed at low pressure from these substations, and by adopting this method there is no more danger connected with the use of alternating current than with direct current. Alternating current is coming rapidly into favor for use in mines in connection with pumping, hoisting, etc., and if properly installed, it is equally effective for lighting purposes, allowing the light to be distributed over wide areas with comparatively small line-wires. In some installations these substations are located above ground, and no high-tension wires whatever are allowed in the mine. If, however, properly

insulated high-tension cables are used, there is no reason why the current can not be carried safely to a substation located in the mine itself. The former is, however, the safer method, although it involves a somewhat greater expense for copper. With 1,000 volts on the primary circuit, about twenty 16 c. p. lamps can be operated per ampere delivered by the dynamo. With 2,000 volts, about forty lamps on the secondary will call for 1 ampere on the primary.

---

### CONDUCTORS.

**54. Material for Conductors.**—Copper wire or cable is used almost exclusively, in connection with mine lighting, for conducting the current from the dynamo to the lamps. The lines are usually in the form of solid round copper wire, but when extra large conductors are required, stranded cables are used. The different sizes of copper wire are expressed according to gauge number, and the gauge most generally used in America to designate the different sizes of copper wire is the American, or Brown & Sharpe (B. & S.). The sizes as given by this gauge range from No. 0000, the largest, .460 inch diameter, to No. 40, the finest, .003 inch diameter. Wire drawn to the sizes given by this gauge is always more readily obtained than sizes according to other gauges; hence, in selecting line-wire for any purpose, it is always desirable, if possible, to give the size required as a wire of the B. & S. gauge. A wire can usually be selected from this gauge which will be very nearly that required for any specified case.

**55. Estimation of Cross-Section of Wires.**—The diameter of round wires is usually given in the tables in decimals of an inch, and the *area of cross-section* is given in terms of a unit called a **circular mil**. This is done simply for convenience in calculation, as it makes calculations of the cross-section much simpler than if the square inch were used as the unit area. A **mil** is  $\frac{1}{1000}$  of an inch.

or .001 inch. A *circular mil* is the area (in decimals of a square inch) of a circle, the diameter of which is  $\frac{1}{1000}$  inch, or 1 mil. The circular mil is therefore equal to  $\frac{\pi}{4} (.001)^2 = .0000007854$  square inch.

If the diameter of the conductor were 1 inch, its area would be .7854 square inch, and the number of circular mils in its area would be  $\frac{.7854}{.0000007854} = 1,000,000$ ; but 1 inch = 1,000 mils and  $(1,000)^2 = 1,000,000$ ; hence the following is true:

$$CM = d^2,$$

*or the area of cross-section of a wire in circular mils is equal to the square of its diameter expressed in mils.*

EXAMPLE.—A wire has a diameter of .101 inch. What is its area in circular mils?

$$.101 \text{ inch} = 101 \text{ mils.}$$

Hence,  $CM = (101)^2 = 10,201.$

Table II, inserted here for convenient reference, gives the dimensions, weight, and resistance of pure copper wire. The weights given are, of course, for bare wire. The first column gives the B. & S. gauge number, the second the diameter in mils. The diameter in inches would be the number as given in this column divided by 1,000. The third column gives the area in circular mils, the numbers in this column being equal to the squares of those in the second column. The safe carrying capacity is also given. Usually the wires are strung in the air in mining work, so that the column headed "Open" may be taken as the carrying capacity. No wires smaller than No. 14 should be used in connection with lighting work.

**56.** When wires larger than those given in Table II are required, stranded cables should be used, because they are much more flexible and easily handled. Table III gives some of the standard sizes of cables.

TABLE II.

**PROPERTIES OF COPPER WIRE.—AMERICAN, OR  
BROWN & SHARPE, GAUGE.**

Number B. & S. Gauge.	Diameter in Mils.	Area in Circular Mils. $C M = d^2$ .	Weights.		Resistance per 1,000 Ft. International Ohms. 75° F.	Current Capacity (Amperes) National Board Fire Underwriters.	
			Per 1,000 Ft.	Per Mile.		Open.	Con- cealed.
0000	460.0	211,600	641	3,382	.04966	312	218
000	409.6	167,805	509	2,687	.06251	262	181
00	364.8	133,079	403	2,129	.07887	220	150
0	324.8	105,534	320	1,688	.09948	185	125
1	289.3	83,694	253	1,335	.1258	156	105
2	257.6	66,373	202	1,064	.1579	131	88
3	229.4	52,634	159	838	.2004	110	75
4	204.3	41,742	126	665	.2525	92	63
5	181.9	33,102	100	529	.3172	77	53
6	162.0	26,250	79	419	.4104	65	45
7	144.2	20,816	63	331	.5067		
8	128.4	16,509	50	262	.6413	46	33
9	114.4	13,094	39	208	.8085		
10	101.8	10,381	32	166	1.010	32	25
11	90.7	8,234	25	132	1.269		
12	80.8	6,529	20	105	1.601	23	17
13	71.9	5,178	15.7	83	2.027		
14	64.0	4,106	12.4	65	2.565	16	12
15	57.0	3,256	9.8	52	3.234		
16	50.8	2,582	7.9	42	4.040	8	6
17	45.2	2,048	6.1	32	5.189		
18	40.3	1,624	4.8	25.6	6.567	5	3
19	35.8	1,288	3.9	20.7	8.108		
20	31.9	1,021	3.1	16.4	10.260		
21	28.5	810.1	2.5	13.0	12.940		
22	25.3	642.4	1.9	10.2	16.41		
23	22.6	509.4	1.5	8.2	20.57		
24	20.1	404.0	1.2	6.5	26.01		
25	17.9	320.4	.97	5.1	32.79		
26	15.9	254.1	.77	4.0	41.56		
27	14.2	201.5	.61	3.2	52.11		
28	12.6	159.8	.48	2.5	66.18		
29	11.3	126.7	.39	2.0	82.29		
30	10.0	100.5	.30	1.6	105.1		

**TABLE III.**  
**CARRYING CAPACITY OF CABLES.**

Area Circular Mils.	Current Amperes.		Area Circular Mils.	Current Amperes.	
	Exposed.	Concealed.		Exposed.	Concealed.
200,000	299	200	1,200,000	1,147	715
300,000	405	272	1,300,000	1,217	756
400,000	503	336	1,400,000	1,287	796
500,000	595	393	1,500,000	1,356	835
600,000	682	445	1,600,000	1,423	873
700,000	765	494	1,700,000	1,489	910
800,000	846	541	1,800,000	1,554	946
900,000	924	586	1,900,000	1,618	981
1,000,000	1,000	630	2,000,000	1,681	1,015
1,100,000	1,075	673			

**57.** The wires used for supplying the current to lighting circuits in mines should be well supported on porcelain insulators. The wire itself is usually covered with a double or triple braiding of cotton soaked in insulating compound. Where extra good insulation is required, rubber-covered wire should be used.

**58. Joints.**—When it is necessary to make joints between wires, it is important to remember that the work can not be too well done. Under no circumstances should a joint be left unsoldered. When connecting a branch line to the main, the insulation is cut away as shown in Fig. 31; the cut should not be made straight down towards the wire with the edge of the knife, forming a sharp shoulder on the insulation, as the knife is very likely to make a nick in the wire, and

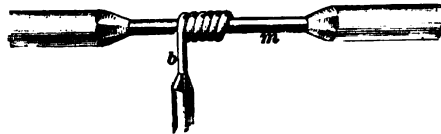

FIG. 31.



subsequent bending might produce a crack at this point. Such a fault would increase the resistance locally and cause heating and, possibly, fire risk. In the illustration, the branch wire *b*, after being carefully bared of insulation and scraped clean, is wrapped over the main *m*, similarly exposed. This operation should be done with a pair of pliers of convenient size, and the turns of *b* should be close together. The joint should then be soldered, no acid being used, but resin only, as a flux, the reason being that it is impossible to clean off all the acid after the joint is finished, as some remains in the crevices and will eventually corrode the wire and break the electrical circuit. When the joint is cool, the wire is held firmly by the solder; all the exposed wire should then be covered by wrapping rubber insulating tape carefully over it, continuing across a short distance on the main insulation. It may here be remarked that it is not so easy to make a resin joint as one on which acid is used, which explains the disfavor in which the former is usually held by poor workers. Acid removes grease from the wire, such as a careless workman may have smeared on from his fingers, but when the wire is not handled after cleaning, resin will



FIG. 32.

make a good joint. An alternative method is to tin both wires before wrapping, using acid as a flux; then wipe carefully, cleaning thoroughly, to remove all trace of acid, and wrap over, using pliers to bend the wire. The joint should then be completed with resin as a flux. When two wires are to be connected together to form a continuous conductor, the Western Union joint, Fig. 32, is employed, the wires being twisted one over the other, soldered, and taped.

---

#### CALCULATING SIZE OF WIRE FOR LIGHTING CIRCUITS.

**59.** The size of wire required to supply a given number of lamps situated a given distance from the dynamo will depend upon the amount of loss that is allowed in the line. The loss

in the line due to its resistance causes a **drop** in pressure between the dynamo and the lamps. For example, if the resistance of the wire through which the current has to flow were  $R$  ohms and the current supplied  $C$  amperes, the pressure which would be used up in forcing the current through the line would be  $C \times R$  volts. This pressure used up in driving the current through the wire is spoken of as the **drop**, because the pressure at the end of the line is less or drops off by this amount from the pressure at the dynamo. If we can afford to allow a large line drop, or, what is equivalent to the same thing, if we can afford to have a large loss in the line, it is evident that we may use a line having a large resistance. This means that the wire may be small and consequently cheap. For distributing from the dynamo to the different centers at which the lights are supplied, a drop anywhere from 5 to 15 per cent. of the lamp voltage is allowed. For local distribution on the branch circuits directly connected to the lamps, the drop should not exceed 2 or 3 per cent., because if it does the lamps will give a very poor light. The aim should be to keep the pressure at the different centers of distribution as constant as possible. If this is done and the drop in the lines running from the centers of distribution to the lamps is small, a good lighting service will result, and the life of the lamps will be much longer than it would be were the voltage regulation bad.

**60.** When the size of wire for supplying a number of lamps is to be estimated, the distance from the dynamo to the lamps must be known; the allowable amount of drop in the line and the current must also be known. The current can easily be estimated from the known number of lamps and their candle-power.

Let  $C$  = current supplied over the line;

$L$  = total length of the line *in feet* (i. e., distance to lamps and return);

$E$  = voltage at end of circuit where lights are located;

$\%$  = percentage drop (i. e., percentage of voltage at the lamps);

$A$  = area of cross-section of wire in circular mils;

$$\text{then, } A = \frac{10.8 \times L \times C \times 100}{E \times \%}, \quad (2.)$$

$$\text{or } A = \frac{10.8 \times L \times C}{\text{volts drop}}. \quad (3.)$$

**EXAMPLE.**—A certain portion of a mine is to be lighted by fifty 16-candle-power, 110-volt lamps and ten 32-candle-power lamps. This portion of the mine is 1,000 feet from the dynamo room, and the drop is not to exceed 5% of the voltage at the lamps. Find the size of wire required.

**SOLUTION.**— 50 16 c.p. 110-volt lamps require 25 amperes.

10 32 c.p. “ “ “ 10 amperes.

Total current, 35 amperes.

The total length of wire through which the current will flow will be  $2 \times 1,000 = 2,000$  feet, because the current has to flow to the lamps and back again. Applying formula 2, we have

$$A = \frac{10.8 \times 1,000 \times 2 \times 35 \times 100}{110 \times 5} = 137,454 \text{ circular mils. Ans.}$$

By looking up the wire table, we find that this corresponds to about a No. 00 B. & S. wire. It is very seldom that a wire will figure out so as to correspond exactly with any size given in the wire table. The next larger size is usually taken rather than the next smaller, unless the smaller size should be quite near the calculated value.

**EXAMPLE.**—Current is to be delivered to a mine 2 miles distant from the power station by means of alternating current at 2,000 volts. The drop in the line is not to exceed 10 per cent. Six hundred lamps are to be operated at the distant end from the secondaries of transformers. Calculate the size of the line-wire required.

**SOLUTION.**—Each ampere on the 2,000-volt primary lines is equivalent to 40 lamps on the secondary (see Art. 53); hence the current will be approximately  $\frac{600}{40} = 15$  amperes. The total length of line will be  $5,280 \times 2 \times 2 = 21,120$  feet; hence we have

$$A = \frac{10.8 \times 21,120 \times 15 \times 100}{2,000 \times 10} = 17,107 \text{ circular mils. Ans.}$$

This lies between a No. 7 and No. 8 B. & S. No. 7 would probably be used, so as to allow a margin for additional lights that might be needed in the future.

### ARC LAMPS ON CONSTANT-POTENTIAL CIRCUITS.

61. Arc lamps are frequently run on constant-potential or constant-pressure circuits in the same way as incandescent lamps. With the older types of arc lamps, it was necessary to connect two lamps in series across the 110-volt circuit, in order to take up the full pressure. It will be remembered that an ordinary open-arc lamp requires about 45 volts; hence if two are connected in series across the line, they will take up 90 volts, and the extra 20 volts must be taken up by a resistance  $R$ , as indicated in Fig. 33, where the arc lamps are

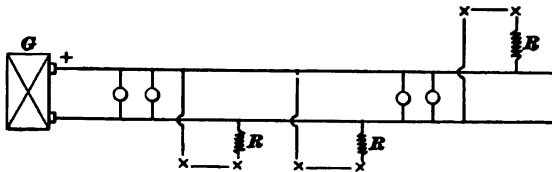

FIG. 33.

shown connected, two in series across a 110-volt circuit. This method of operating arc lamps is not, on the whole, very satisfactory, because the two lamps are apt to interfere with each other and not feed properly. This method of running open-arc lamps is being rapidly superseded by the use of the enclosed-arc lamp. As already stated, the enclosed arc requires from 75 to 85 volts for its operation and may be connected directly across a 100 or 110 volt circuit by the insertion of a small amount of resistance. Such lamps are very often convenient for use about mines, because they can be operated from the same dynamo and off the same mains that supply the incandescent lamps.

### PROTECTION AGAINST SHORT CIRCUITS.

62. Before leaving the subject of lighting as carried out on constant-potential systems, it may be well to point out the necessity of protecting such systems from **short circuits**. It must be remembered that the pressure between

the mains is maintained at a constant value by the dynamo. Compound-wound dynamos are generally used, and these machines maintain the pressure at a nearly uniform value, regardless of the amount of current they are called upon to furnish. From Ohm's law,  $C = \frac{E}{R}$ , it is at once seen that if  $E$ , the E. M. F., is kept constant, the current will depend upon the resistance between the two lines. If the resistance is high, the current will be small, but if the resistance is very low, the current may become dangerously large. If the two line-wires should be accidentally connected together, or, in other words, if a *short circuit* should be established between them, there would be a large rush of current, which might be sufficient to fuse the wire. Such short circuits are liable to occur, on account of accidents of various kinds, and it is necessary to provide some protection against them. In lighting work, this protection is generally provided for by means of fuses. These are usually in the form of a short piece of wire or strip made of a soft, fusible metal, which will melt and cut out the defective part of the circuit whenever the current reaches a dangerously high value.

**63.** The fuses are mounted in **fuse blocks** or **cut-outs**, and should be placed wherever a branch circuit is taken off the main line. A small fuse should also be placed in series with each individual lamp, especially if such lamp is hung from a drop cord.

Fig. 34 shows a cut-out of the kind referred to. It is called a rosette cut out and is principally used where a lamp drops from the supply wires. The figure shows the inside view of the two halves. They are both composed of porcelain, upon which metallic connection pieces are screwed. The half  $B$  is fastened in place through the holes  $h$  and  $h_1$ . The supply wires are connected to the binding-posts  $p$  and  $p_1$ , which are themselves connected to the two projecting elastic plates of metal  $c$  and  $d$ .

The half  $A$  has two projecting metallic pieces  $m$  and  $n$ , which hook in under  $c$  and  $d$  and make the connections when

the two halves are put together. The side view of *m* or *n* is given at *f*. Upon each of these pieces at the end that rests against the porcelain is a binding-screw *s* or *x*. Two small metallic plates, each carrying a pair of binding-screws *t* and *v*, or *z* and *y*, are screwed upon the porcelain at diametrically opposite points, and the lamp conductors,

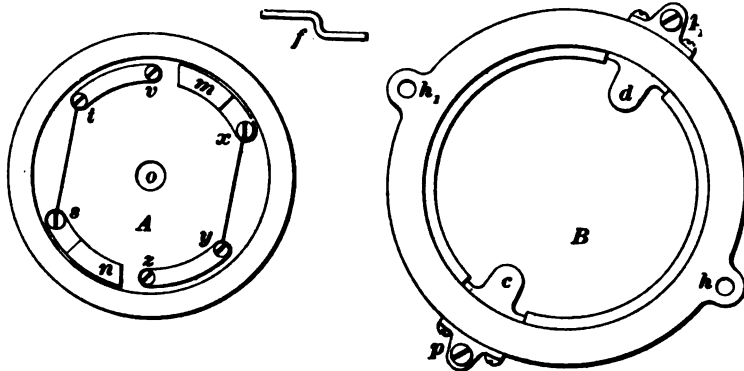

FIG. 34.

entering at hole *o*, are connected to *v* and *z*. If flexible cord is used, it should be knotted under the cap, in order to sustain the weight of the lamp. Between the two binding-screws *t* and *s*, as well as between *x* and *y*, are respectively connected two strips of a fusible alloy. This alloy melts and breaks the circuit when the current increases above a given value.

The current starts from one supply wire and flows through *d*, *m*, and the alloy or fuse wire *x y* to *z*. Then it flows through the lamp to *v*, through the fuse wire *t s* to *c*, and out to the other supply wire. The two halves are connected by a screwing motion, which rubs the contact pieces together.

64. The ordinary form of detachable fuse is shown in Fig. 35. The contact pieces *a* and *b* are made of sheet copper, and are intended to be clamped by screws to the terminals provided for them on the fuse blocks.



FIG. 35.

A strip *c* of fusible lead alloy is soldered to each contact piece, its cross-section being proportional to the maximum current to be carried, which is stamped on the copper ends. As a guide to the carrying capacity of fuses, the following table may be consulted, but it is to be pointed out that the fusing current depends upon the particular proportion of the metals used in the alloy and their selection, also on the length of fuse and the character of the terminals.

TABLE IV.

Diam. in Mils.	B. & S. Gauge (Approx.).	Amperes.
.017	25	3
.020	24	4
.032	20	7
.042	18-17	10
.056	15	15
.065	14	18
.075	13-12	25
.085	12-11	28
.096	11-10	31
.111	9	36
.130	8	50
.150	7-6	70

65. Fuse blocks are nearly always made of porcelain or slate and are of a great variety of styles, depending upon

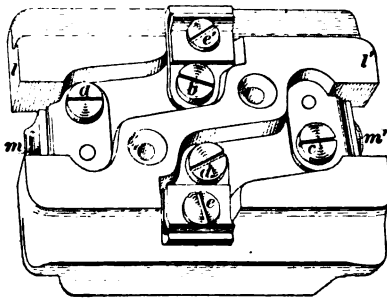

FIG. 36.

the use to which they are to be put, their current capacity, etc. Fig. 36 shows a **branch block** used where a branch circuit is to be taken off the main line. The mains may be connected at *m*, *m'*, the wires passing under the projecting ledges *l*, *l'*. The branch wires are secured

at  $c, c'$ . The fuses are held between the screws  $a$  and  $b$ ,  $c$  and  $d$ . To prevent damage when a fuse "blows" or melts, a porcelain cover is fitted over the face of the block.

Fig. 37 shows a **main fuse block**, the wires from the point of supply being inserted at one end, as at  $m, m$ , and the line

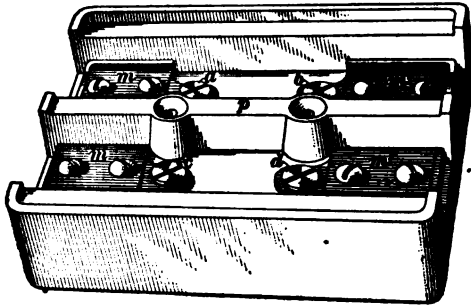

FIG. 37.

continued from the terminals  $m', m'$  at the other end. The fuses are inserted between the screws  $a$  and  $b$  and between  $c$  and  $d$ . The two sides of the circuit are separated by the partition  $p$ , so that all danger of short circuit is eliminated. This fuse block is also provided with a porcelain cover not shown in the figure.

**66.** When fuse blocks are installed in mines, they should always be placed at some easily accessible point, so that they may be readily examined and fuses replaced when necessary. It is a good plan to place the blocks in a wooden box painted with waterproof paint and provided with a hinged door.

### SWITCHES.

**67.** Switches used in connection with incandescent lighting may be of the **single-pole** or **double-pole** variety. In the former, one side only of the circuit is opened by the switch, while in the latter both sides are opened. Where small groups of lights are to be controlled, say 6 or 8 lights, a single-pole switch will answer; but where the number of lights is at all large, double-pole switches should be used.



The most durable type of switch is the knife-blade type described in Art. 123, *Dynamos and Motors*, Part 3. Such switches, mounted in wooden boxes painted with weather-proof paint, make a very good arrangement for mining work. These switches are much more durable than the ordinary snap switches, such as are frequently used in connection with electric wiring. It is always well to mount the switches, no matter what kind is used, in a protecting box of some kind.

**68.** It must be said, in regard to most of the snap switches on the market, that they are very flimsy. Of course some of them are much better than others, but, as a general rule, they do not stand the hard usage they are liable to get in a mine. For this reason, a good substantial knife switch is to be preferred. We give, however, a couple of examples of typical snap switches which, if not abused, will give good service. They have one advantage in that they are more easily operated in the dark than a knife switch.

**69.** The style of switch shown in Fig. 38 is suitable for use on circuits where the current does not exceed 50 amperes.

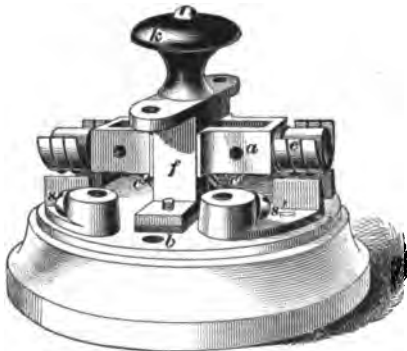

FIG. 38.

The positive and negative leads are brought up through the hole in the base *b* and connected one to each of the terminals shown by means of the screws *s, s'*. The leads for the lamps are connected in a similar manner to corresponding terminals on the other side of the switch, and the circuit is completed by forcing the arm *a* into contact with these terminals, thereby bridging over the gap between them. The knob *k* is fastened to a pin passing vertically through the frame *f* and secured to the springs *c, c'* at the lower end in such a way as to form a toggle-joint. When the knob

is drawn upwards, the springs are compressed, and on passing the center, they suddenly force the contact arm downwards. In like manner, on pressing the knob down, contact is again broken.

**70.** Fig. 39 shows a double-pole switch for small currents. The cylinder *e*, made of china or other insulating substance, has brass contact plates *p* on opposite sides, against which press brass or copper springs when the cylinder is in the position indicated in the figure. Four terminals are provided, lettered *a*, *b*, *c*, *d*, and the wires for connection to them are brought up through the holes in the base, one of which is visible. The incoming wires, positive and negative,



FIG. 39.

are connected to the terminals *b* and *d*, and the outgoing wires to *a* and *c*. The springs *a'*, *b'*, *c'*, *d'* are riveted to the terminals *a*, *b*, *c*, *d*, respectively, so that when the switch is turned to the position shown, the circuit is completed between terminals *a* and *b* and between *c* and *d*. A quarter-turn breaks the contact, for the springs then rest only on the china cylinder. A cover is provided to enclose the body of the switch, the handle alone projecting.

**71.** Sometimes it is very convenient to have switches arranged so that an incandescent lamp or group of lamps may be turned on or off from either of two points. This may be accomplished by using two "3-point" switches as shown in Fig. 40. *L*, *L* are the lamps to be controlled from the two stations *A* and *B*. The switches *A* and *B* have three points, since the contact plates *a*, *a'* are connected together

and practically form a single terminal. The contact arm of the switch is thrown from the position shown to that indicated by the dotted line when the switch handle is turned.

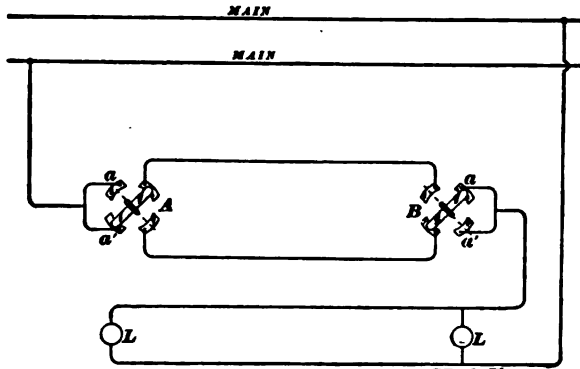

FIG. 40.

By tracing out the connections, it will readily be seen that the lamps may be turned on or off from either station without regard to the position of the switch at the other station.

**72.** By an extension of the arrangement just mentioned, lamps may be controlled from three or more stations.

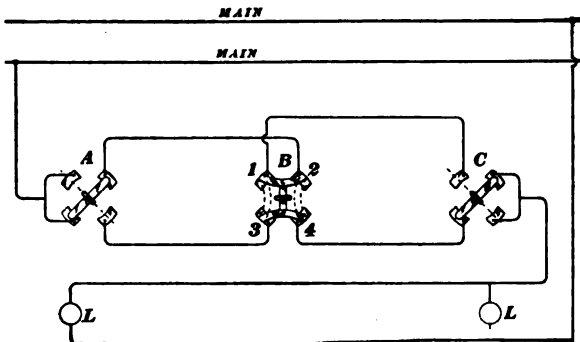

FIG. 41.

Fig. 41 shows how this is carried out for three stations by using two 3-point switches *A* and *C*, one for each end station, and one 4-point switch *B* for the center station. As

shown in the figure, the points 1 and 2, 3 and 4 of the 4-point switch are connected together. When the switch is turned, points 1 and 3, 2 and 4 are connected, as shown by the dotted lines. By this arrangement, the lights may be turned on or off from any one of the three stations. This scheme can be extended to any number of stations by adding another 4-point switch for each additional intermediate station.

### SERIES ARC-LIGHT SYSTEM.

73. All the lighting so far mentioned has been carried out on the constant-potential system, the lamps being connected in parallel. When a number of scattered arc lamps are to be operated, the **series system** is commonly used. In this case the lamps  $l$  are connected in series, as shown in Fig. 42. The same

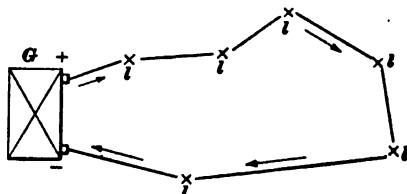
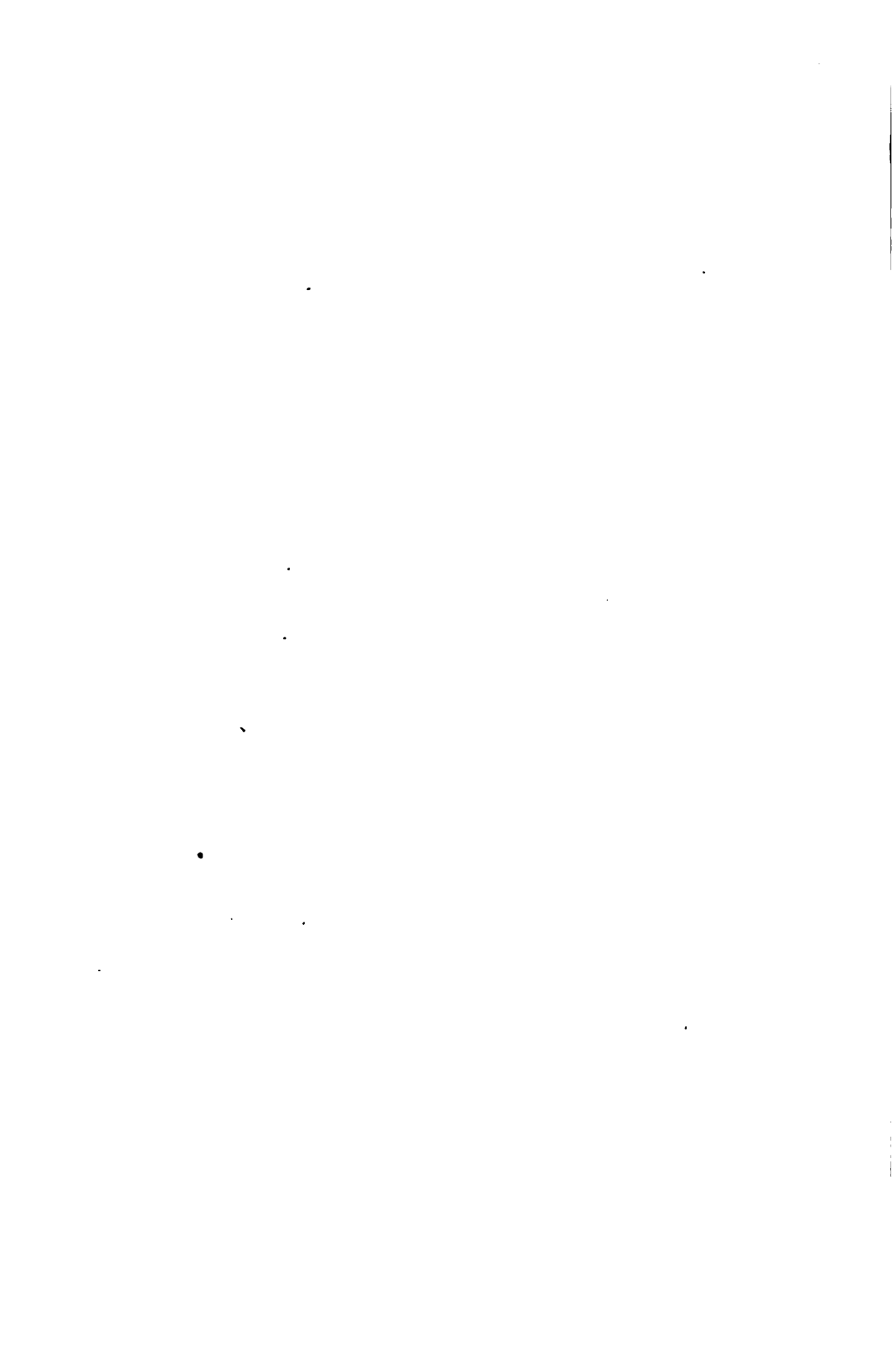

FIG. 42.

current flows through all the lamps, leaving generator  $G$  at the positive pole and flowing through each lamp in succession back to the negative pole. In a circuit of this kind, the current must be maintained at a constant value, because the current through the lamps must always remain at the same amount if the lamps are to operate in a satisfactory manner. If a large number of lights are burning, a high pressure must be generated by the dynamo (about 45 or 50 volts for each lamp in operation). If, on the other hand, most of the lamps are cut out, the pressure required will be small, and the E. M. F. generated by the dynamo must be cut down, in order that the current may remain constant. This is accomplished by providing the dynamo with an automatic regulator, which causes the E. M. F. generated to decrease whenever the load decreases, and *vice versa*. The size of line generally used for arc-light circuits is No. 6 or 8 B. & S.



# ELECTRIC COAL-CUTTING MACHINERY.

---

## **ELECTRIC COAL-CUTTING MACHINERY.**

1. In the production of bituminous coal, the question of decreasing the cost has received much consideration, and the reductions in this respect, as in almost all others, have been made in large part by the use of labor-saving machinery. Another reason which has led to the introduction of coal-cutting machines is found in the fact that a greater output can be obtained from a limited territory with more certainty, steadiness, and reliability than can be depended upon when pick mining is used. As the most difficult and expensive operation in connection with the production of bituminous coal is the process of undercutting, the greatest development has been made in machinery for accomplishing this operation. This method of mining is confined to the bituminous fields, the anthracite coal being simply blown from the solid.

In order that the bituminous coal may be made into the best marketable form, it is first undercut and then blown down with as small a charge of powder as possible. Many machines have been designed and built to undercut coal; and machines for this purpose have reached such a degree of perfection that it can safely be said that a large, if not the greater, proportion of coal cutting will in the future be done by mechanical means. The flexibility and convenience of the electric system, together with many other advantages peculiar to existing conditions, makes it admirably

adapted to the present bituminous fields throughout the world.

In many mines the conditions are more favorable to the use of machines operated by compressed air, and where such conditions exist there is but one alternative. There are three principal conditions which particularly favor compressed-air machines, these being bad roof, explosive gas in dangerous quantities, and frequent occurrence of pyrite or other hard substance which can be worked around with a pick machine which uses compressed air, but which would break the teeth or other parts of a chain-cutting machine. In mines where the roof is bad and it is necessary to place the props close to the face, requiring a machine which can be operated in very narrow places, the pick, or puncher, machine is the only one which can be used. Pick machines are usually operated by compressed air, but recently electricity has been successfully applied to machines of this type. Machines operated by alternating-current motors which are practically sparkless have been built and several plants installed, but this system has proved to be unsuitable for machinery designed for this class of work, principally on account of the danger to men and animals. The few plants that were installed are entirely abandoned. The continuous-current motor is consequently the only one being used.

---

### **TRANSMISSION OF ELECTRIC ENERGY TO MINING MACHINES.**

2. The flexibility of the electric system of transmitting energy, together with its low cost and high efficiency, makes it especially suitable for undercutting machines, which are used at the working-faces of the entries and rooms. The current is carried through the main and cross entries by wires forming a complete circuit with a positive and negative side, the cross-section of wire used being determined by the amount of current required to be carried, this wire being supported on glass insulators, which are attached to timbers

or props. From the entries the power is taken to the working-faces of the rooms by means of an insulated cable, these cables being of sufficient length to reach the face of the room when it has been worked to its greatest depth.

3. As it is more economical to transmit power at high than at low voltages, this feature in the transmission of electrical power has received much consideration where it is desired to carry power from a central plant to several mines which are situated a number of miles from the central station. By using high voltages, small wires can be used and a very great reduction in the cost of this portion of the plant can be made. In order to transmit power at high voltages, it is necessary to use the alternating-current system, and in order to adapt this to the direct-current motor on the machines or locomotives, it is necessary to transform it to a direct current of low voltage. That this may be done, it is necessary to employ a rotary transformer or motor generator. The advisability of using this system depends entirely upon local conditions, and should be determined upon the basis of comparative initial and operating expenses.

4. In constructing circuits about mines, care should be taken to place the wires as much out of the way of men and mules as possible. There is always danger connected with coming in contact with an electrical circuit, and those who are required to work in connection with construction of circuits should be provided with tools properly insulated, wear rubber gloves, and when working with the wire, stand upon some insulating material such as rubber or dry wood. Fatalities in mines due to contact with wires are rare and generally in connection with alternating-current machinery. The voltage used with direct-current machinery is so low that very little danger exists from contact with the wires. As some persons are more affected by an electric shock than others, it is best to caution all workmen of the danger of coming in contact with the wires.



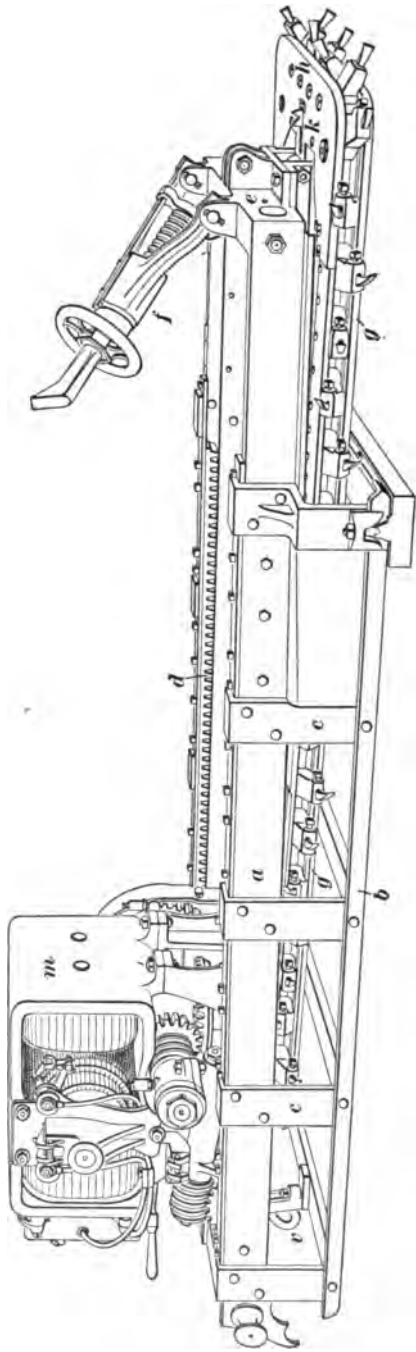

FIG. 1.

**CHAIN COAL-CUTTING MACHINES.**

5. Fig. 1 is an illustration of one of the leading types of electric chain coal-cutting machines. It consists of an outside or bed frame and inside or sliding frame and an electric motor. The outside or bed frame is made of two steel channel-bars *a* and two angle-bars *b* fastened together by means of heavy cast and forged steel cross-ties or braces *c*. The feed-racks *d*, which are made of the best rolled steel and have machine-cut involute teeth, are firmly bolted to the bed-frame. These racks are made up in sections, so that in case a tooth should be broken it can be replaced without renewing the entire rack. The rear end of the bed-frame is provided with hooks for moving the machine and a cross-bar on which rests the rear jack or the brace which passes to the roof to take the backward thrust of the machine. A heavy steel cross girt *e* joins the channel-bars at the front end of the bed-frame. The front jack *f* is mounted on the cross girt and the guides for the center rail of the sliding cutter frame are attached to the bottom of it. These guides consist of two adjustable bronze parts of extra length to give large wearing surface for the bearing of the center rails. As the floor of a mine is very uneven and would seldom be level enough to allow the machine to have a firm bearing, the outside frame is designed strong and rigid, so that there can be no bending due to irregularities in the floor. The rigidity of this frame does away with the friction caused by lighter and less rigid construction.

The inside or sliding frame is the shape of an isosceles triangle with the apex at the rear, and consists of a steel center rail, a cutter-head *h*, and two side chain guides *g*. This sliding frame is contained wholly, with the exception of the cutter-head, within the stationary bed-frame, which arrangement insures perfect protection to persons while it is in operation or when it is being moved from one place to another. As this frame comes in direct contact with the coal, it is made strong and has large wearing surfaces, and since its shape is triangular, only three wheels are required

for the cutter chain, two sheaves or idlers in the cutter-head and one a driving sprocket at the apex of the frame. The center rail is secured to the sliding carriage on which the electric motor is placed by means of a steel step casting. A holder *k* is placed in the center of the cutter-head to take a portion of the side thrust of the chain when cutting coal. The driving mechanism consists of two steel spur-wheels and two steel bevel-gears, while the feed and pull-back mechanism consists of a system of worms and wheels.

The motor *m* is of the multipolar iron-clad type. The field frame is of cast steel and so proportioned as to make a compact and symmetrical appearance. The commutator is of high-grade hard-drawn copper. The frame of the motor surrounds the field coils and armature in such a manner that they are thoroughly protected from injury by falls of roof or dripping of water. The feed mechanism is automatically thrown out at the end of the cut and the cutter frame travels back from the face until it reaches a point where it automatically throws out the clutch and stops. The machine makes a cut 6 feet deep in about  $3\frac{1}{2}$  minutes and backs out or withdraws from the cut in about 40 seconds. Machines of this type are built to undercut from 5 to 7 feet deep, 39 to 44 inches wide, and about 4 inches high.

6. Fig. 2 shows a chain cutter which is constructed in a somewhat different manner than the one shown in Fig. 1. This difference exists principally in the construction of the stationary frame, which is much lighter, and in the position of the armature, which is vertical instead of horizontal. This machine weighs about 3,000 pounds and will advance while making a cut in the coal in about 4 minutes, and return in about 1 minute. On either of the above machines the time of feed or return can be changed by substituting different gears, the ratio of the gearing depending upon the quality of the coal in which the machine is working. The total length of the machine of this type which will undercut to a depth of 6 feet is about 10 feet over all, the height being

about 29 inches over all. The width of the machine at the cutter-head is 42 inches over the chain and 45 inches over the bits or cutters, these not being shown in the figure. The width across the bed-frame is 24 inches. This enables the machine to be loaded on a truck which will run on a track having a gauge as narrow as 28 inches. The motor is of the multipolar type with internal fields. The armature is of the toothed Gramme ring type with the coils wound in slots

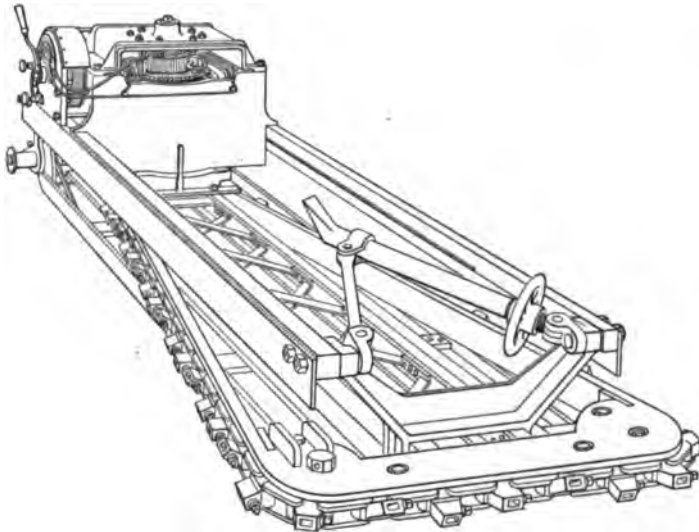

FIG. 2.

below the surface of the armature. This, as in the former machine, protects the coils from danger by rough usage and in case of accident. The field coils are wound on spools that slip over the pole-pieces and can be easily removed.

The gears are made from steel, the teeth being cut out of the solid, thus making the gear solid with the shaft on which it works. The armature being mounted in a vertical position, the pinion on its shaft meshes with a large spur-gear which carries the main drive sprocket. The speed of the chain on this machine is about 273 feet per minute when the armature is running at 750 revolutions per minute at

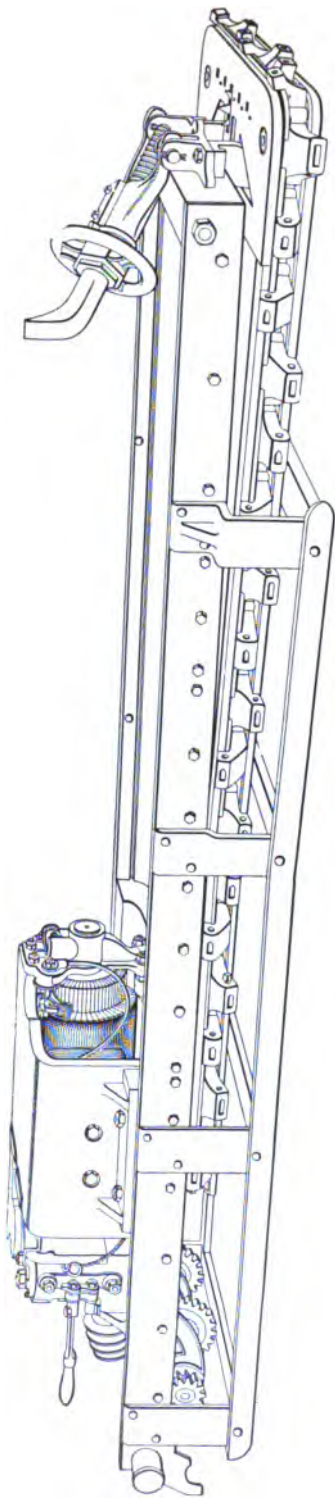

FIG. 3

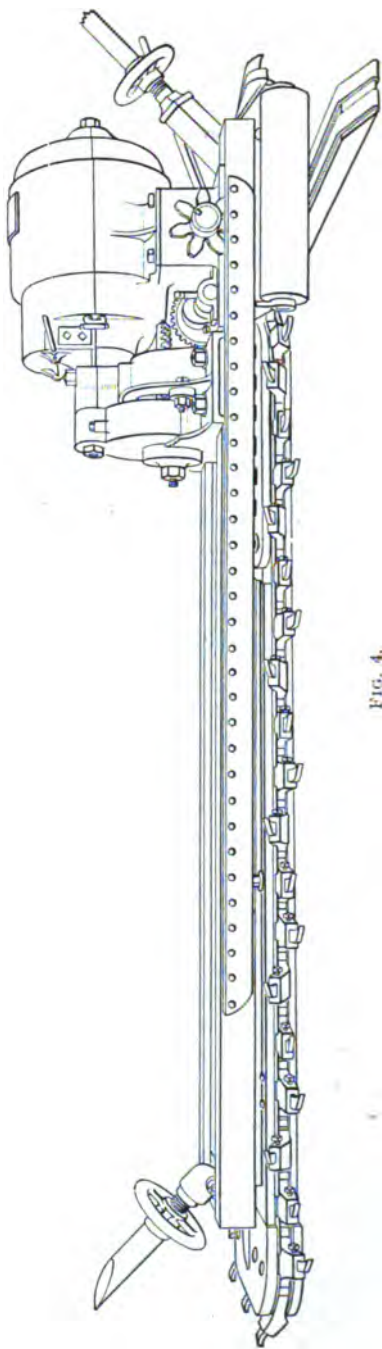

FIG. 4

220 volts. The general construction of this machine will be understood from the description of the previous one.

The chain used on these machines is of the three-position style, having up, down, and center position bits. All the bits are straight and of the same length, which greatly facilitates the redressing and replacing of them.

7. Much attention has been given lately to the construction of electric machines to be used in mines where the seam of coal is low, and such machines have been designed, and their installation at many mines has proved the practicability of working machines in seams as low as 28 inches. Fig. 3 shows one of these machines. It is essentially the same as the one shown in Fig. 1, but it is much more compact, measuring only 18½ inches over all in height.

8. Another type of the chain-cutting machine is shown in Fig. 4. One of the points of difference between this machine and those previously described is that all the stationary parts of the machine are above the moving and cutting parts. The stationary frame is supported by a shoe at its forward end (not visible in the illustration). This shoe is on a level with the lower row of cutting bits, so that the cut is made even with the floor of the room and no coal is left to be removed by hand. Another feature of this machine is the rollers attached to the rear end to facilitate moving it along the face of the coal. While the machine is at work the rollers are securely locked in place. The style of motor is also different from those previously shown. The motor, which is of the multipolar type, is enclosed in a barrel-shaped, dust and water proof iron casing. The armature shaft is longitudinal with the machine. At its front end is keyed a cut spur pinion 3½ inches in diameter and having a 3-inch face. This meshes into an intermediate gear of steel 14½ inches in diameter and a 3-inch face. A forged-steel bevel pinion is keyed rigidly to this intermediate gear and meshes into a cast-steel bevel-gear with cut teeth. This bevel-gear is attached to a sleeve

which revolves on a vertical shaft, the main driving sprocket which actuates the cutting chain being keyed to the lower end of this sleeve.

The chain, cutting bits, and feed mechanism with automatic cut-off at the end of the cut and return travel are common to all these machines, the two first being practically the same in all.

There are other machines which have been built and experimented with, but are obsolete types. Among these is the three-phase alternating-current machine, which has for reasons already named been discarded. A careful study of one of the above types will give an insight into the general construction of machines for undercutting coal, and a closer study of each machine will be necessary to become familiar with the minor details wherein the differences in construction exist.

9. Fig. 5 shows a side view (*a*) and a front view (*b*) of a portion of a cutter chain. It also shows a bit or cutter (*c*), which is made of good tool steel. The chain carrying the cutter is subjected to great stresses and wear and tear, and

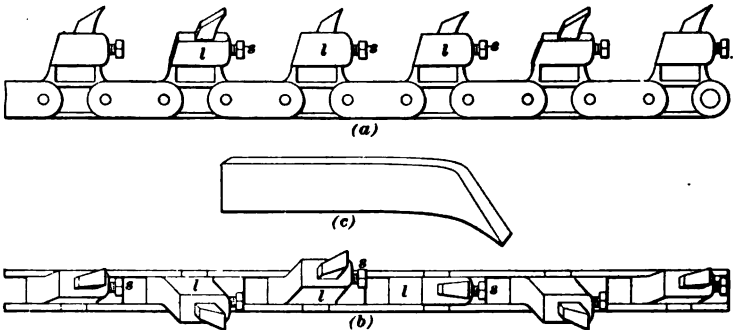

FIG. 5.

consequently must be made strong and of as few parts as possible. Since it is necessary to sharpen the cutters frequently, some easy means of detaching them must be provided. This is done by having a socket in each solid link,

or every alternate link *l*, in the chain, into which the bit will fit. After the bit is placed in this socket, it is held in place by means of a set-screw *s*, which is adjusted from the side of the link.

---

**METHODS OF OPERATING AND HANDLING CHAIN-CUTTER MACHINES.**

**10.** By referring to Fig. 6 a very good idea can be obtained of the manner of operating these machines. For transporting the machine from point to point about the mine, a truck such as is shown in Fig. 7 is used. The machine is loaded on this truck and drawn into the room by a mule or its own motor. It is then unloaded and placed directly in front of the working-face at the point where it is desired to begin undercutting, and leveled up to conform to the bottom of the seam of coal. Under the rear end of the machine is placed an oak skid board, upon which is riveted two pieces of half-round iron, upon which the machine can be slid along easily after each cut is completed, the machine resting at the front end on an oak shoe covered with boiler-plate, thus forming a smooth surface upon which to slide when being moved. By means of a rear jack *a*, which is braced firmly against the roof, and the front jack *b*, which is braced firmly against the face of the coal, the machine is held rigidly in place and is prevented from moving in any direction. Two men are required for each machine, an operator, shown in the figure, and a helper. As the chain drags the cuttings out, it is the helper's duty to shovel them back and help the operator move the machine from time to time along the face of the room as each cut is finished. When the room is entirely undercut, the machine is again loaded on the truck and taken to the next room, where the same operation is performed.

**11.** The cut made by the chain machine is of the same height from front to rear. The average cut of a chain machine is 6 feet deep, 44 inches wide, and 4½ or 5 inches



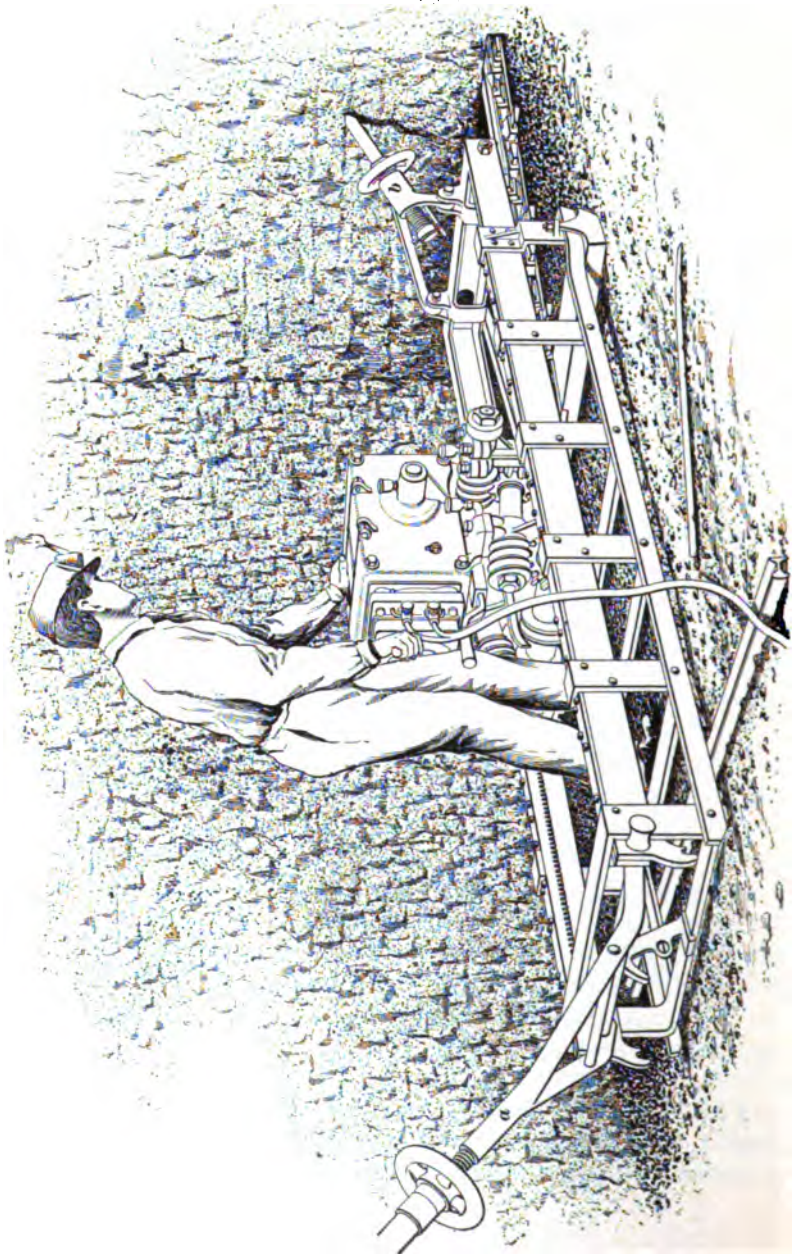

FIG. 6.

high. For such a depth the height of the cut is very low, and the amount of small coal made is but 60 per cent. of that made with pick machines. This is not always an advantage. With some coals this small cut is not enough to allow the coal to fall down and out after the blast. It frequently is necessary for the miners to break down a portion of the coal above and near the front of the cut or lift some of the coal left on the bottom in order to permit the coal to fall well for loading.

On account of the nature of the work, the machines are built to stand a good deal of rough usage, but it is well to impress upon the runner the necessity of taking proper care of his machine. The motor in each of the machines described is protected by a dust and water proof casing, and care must be taken to keep it so, and such bearings as are necessarily exposed to the dust of the mine should be frequently cleaned and kept well oiled. The bits should not be allowed to get very dull. One of the duties of the pit boss should be to see that the runner keeps his machine in good working order, and that the supply wire from the entry to the machine is properly insulated at all times.

**12.** The height of the seam influences the facility with which the machine can be operated. In a  $3\frac{1}{2}$ -foot seam three men are usually required to handle a machine to advantage. About 35 cuts per shift of 10 hours can be made under such circumstances, provided other conditions are favorable, while in high seams two men handling the same kind of a machine can make about 60 cuts per shift, and under exceptionally favorable conditions, records of from 80 to 120 cuts per shift have been made. The most suitable height of seam for machine mining is about 5 feet.

**13.** When a ball of sulphur is encountered and the machine is stopped by the obstruction or by the operator as soon as he notices that it is being damaged and not likely to remove the hard material, it is often found effective to reverse the machine, in order to clean out the cut, and remove some of the cutters which come directly in contact

with the sulphur ball, and finally start the machine forwards again. In this way the cutters that are left cut over or under the sulphur ball and those which are in line with it will suddenly take a deep hold, and on account of the increased speed of the machine, possibly remove the sulphur entirely and in one piece. The dull and broken cutters are in low seams usually replaced with sharp ones when the machine is on the heading between the rooms, as the men have here plenty of room to work. This does not interfere with the gathering drivers, as the undercutting is generally done at night, because the miners who are paid by the ton for shooting down the coal and loading it into the mine cars object to the machines being brought into the rooms while they are at work.

**14.** The truck shown in Fig. 7 is the one most commonly used with the cutting machines. In loading the machine,

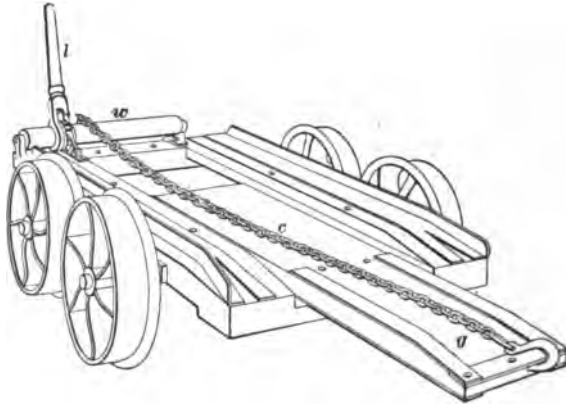

FIG. 7.

the guide *g* of the truck is lowered, so that the rear of the machine will readily slide on to it, and a hook attached to the chain *c* is placed in the ring provided for it in the brace *v*, Fig. 1, at the rear of the machine, which is finally drawn on to the truck by means of the windlass *w* that is operated by the ratchet-lever *l*, and when in position is ready to be moved.

15. Fig. 8 shows a power truck which is operated by the motor of the machine. This truck consists of a well-built frame mounted upon axles and fitted with wheels. A spool with ratchet-wheel, pawl, lever, and chain is mounted on one end in the same manner as on the standard truck.

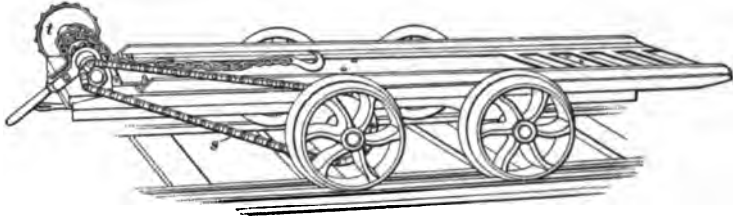

FIG. 8.

Power is transmitted by a chain to the sprocket-wheel *t*, and thence to the truck wheels by means of the chain *s*. The machine is equipped with a clutch, which can be thrown in and out of gear when necessary. When it is desired to utilize the power of the motor to propel the truck, the motor is thrown out of gear with the cutting part of the machine, so that when moving from point to point about the mine, no part of the machine is in motion except that which is necessary to operate the truck. The motor is equipped with a reversing-switch, which allows the truck to travel in either direction as desired. This attachment is being rapidly adopted, as it facilitates moving the machine about the mine, and being entirely independent of a horse or mule, it is especially valuable in thin veins and on heavy grades.

---

**CHAIN-SHEARING MACHINES.**

16. Fig. 9 shows an electric chain-cutter shearing machine, which is used principally for entry driving or turning off rooms from the butt entries; it is also used for shearing in rooms when it is difficult to make lump coal by blasting the **tight**, as the miners term the first shot in blasting down the coal over the undercut. Without the use of shearing

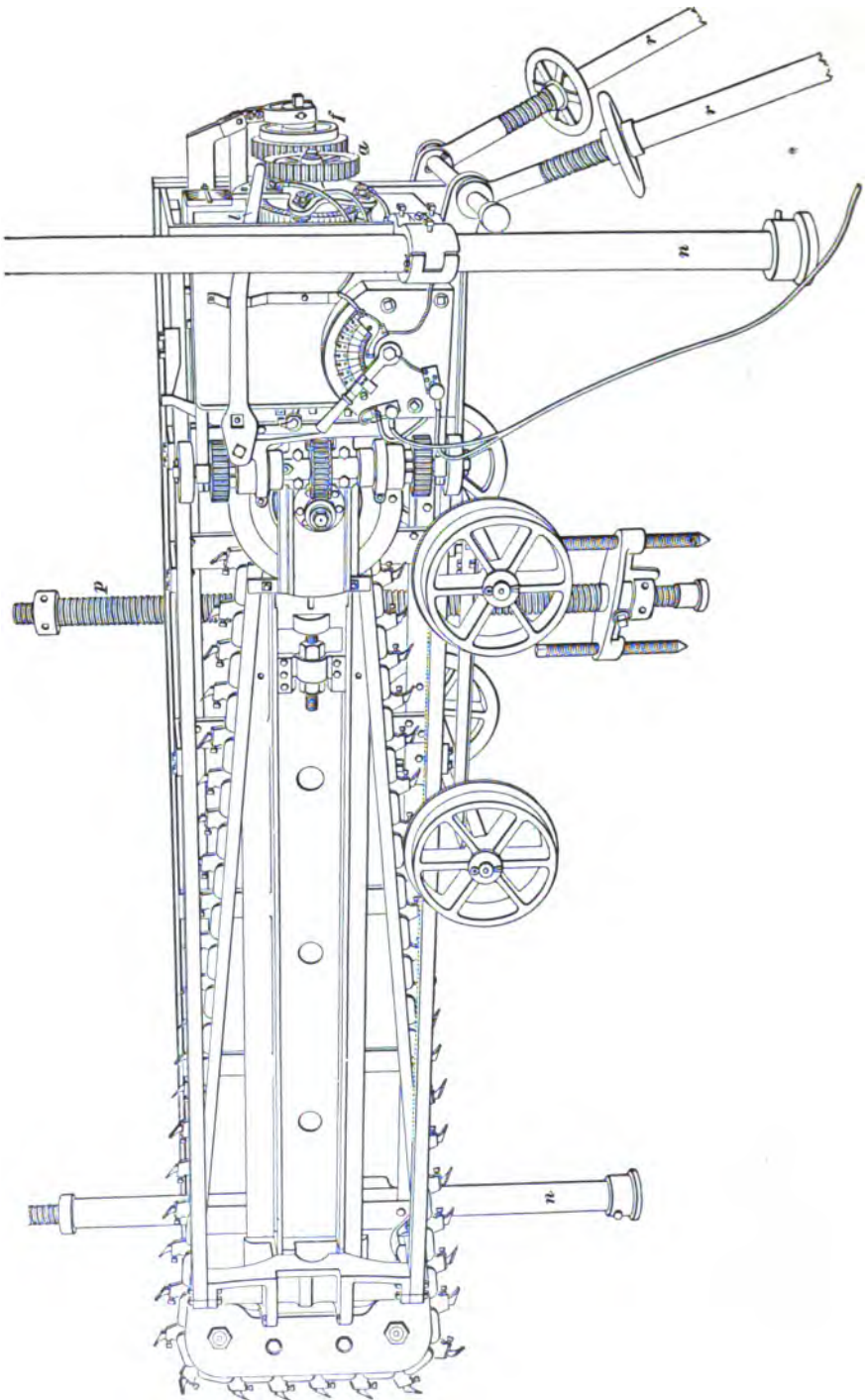

FIG. 6.

### § 33 ELECTRIC COAL-CUTTING MACHINERY. 17

machines, most of the coal mined in narrow work is quite fine, because so much powder is required to bring it down. This is especially true of the coal made by the tight shot in narrow work.

This machine is essentially the same as that shown in Fig. 2, except that it is mounted on its edge on a truck and provided with gear mechanism for raising it when necessary. This mechanism is driven by the motor, and consists of the spur-gears *a* at the rear of the machine and a rod that runs from these gears back to the column *p*, which is provided with coarse threads. On the end of this rod there is a worm that engages a worm-wheel screwed on the column *p*. When it is desired to raise or lower the machine, this set of gears is made to turn the rod and worm-wheel by throwing in the friction-clutch *f* by means of the lever *l*. As the worm-wheel is turned in the proper direction to raise the machine, it presses against a shoulder or cup so pivoted that the machine may slightly turn on a longitudinal axis without detriment to any part of the hoisting device. The machine is further steadied by the columns *n* on opposite sides and the rear jacks *r*. It will be noticed that the truck is rigidly attached to the machine. Before making a shearing in an entry, for instance, the road can be temporarily shoved to one side, whereby the machine can be run directly to the proper place to commence work. The action and method of operating this machine are precisely the same as that described for other chain-cutter machines. Each cut made by this shearer is 7 feet deep and 3 feet high if desired.

17. Another type of shearing machines is shown in Fig. 10. This machine is supported on four columns or jacks and is provided with mechanism for raising and lowering it. The construction is quite similar to the chain-cutter mining machine. There is a bed-frame, sliding chain-cutter frame, and a motor carriage. The bed-frame consists of two rectangular steel channel-bars and two steel angle-bars firmly fastened together by means of heavy cast-steel braces. A heavy steel casting joins the channel-bars at the

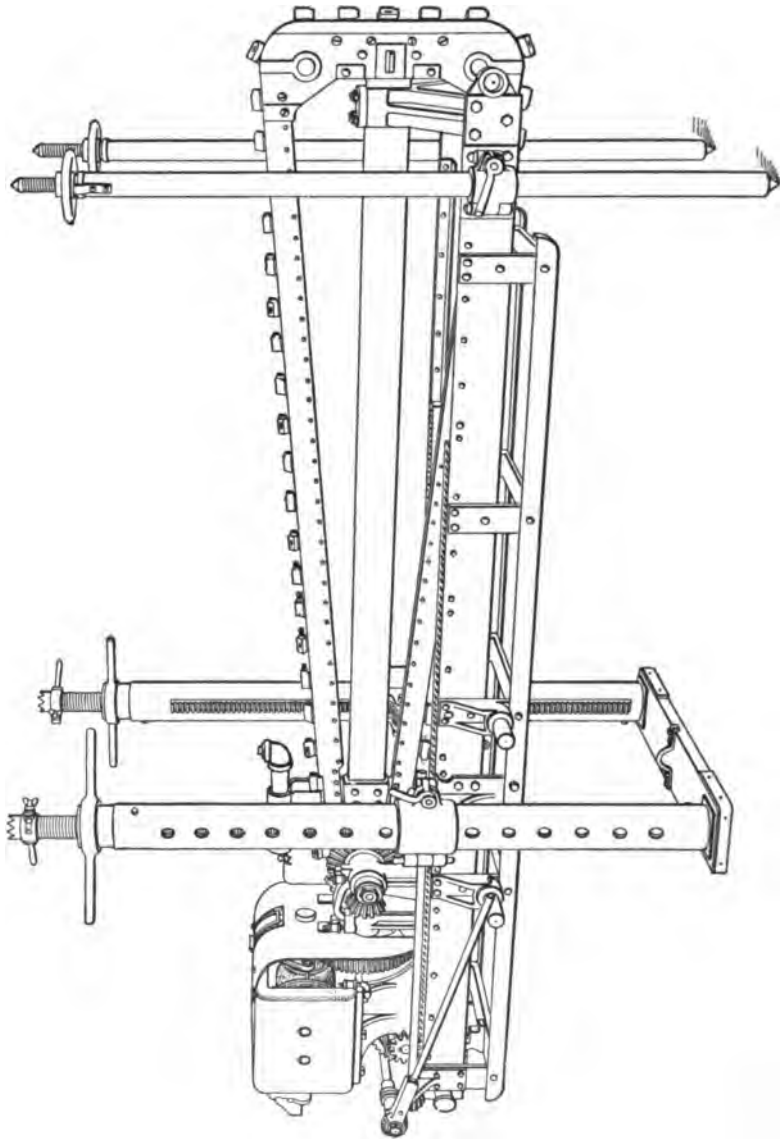

FIG. 10.

front end of the bed-frame and forms the jib or guide for the cutter frame. At the front extremity of the channel-bars two lugs are riveted for supporting the split clamp for the front jack. The supports for the main jacks are located between the center and the rear of the bed-frame, and the bearings for the truck wheels are placed on each side of these supports. The cutter frame consists of a steel center rail, a cutter head, and two steel guides in which the cutter chain runs.

The motor is of the four-pole type with Gramme ring armature and two field coils. The frame consists of one casting, which protects the armature and coils from water and falls of roof.

To operate this machine, it is first placed in position on the floor, the jacks properly set and adjusted, and the machine raised to the top of the vein where the first cut is made. Each cut is 7 feet deep, 3 feet high, and 4 inches wide, and can be made in from 6 to 7 minutes.

---

**CONDITIONS FAVORABLE AND UNFAVORABLE TO CHAIN-CUTTING MACHINES.**

**18.** The careful study of conditions and the rapid development of the undercutting chain machine has made it possible to mine coal with this type of machine under almost all conditions, as machines are built for both thick and thin seams, to cut in hard material by varying the speed of the moving parts, and, in fact, to be used, we might say, in any district where bituminous coal is being produced. It is true, however, that certain local conditions preclude without question the use of a machine of the chain type. Such objections are found to be large quantities of iron pyrites, occurring in the form of a ball or slab at the bottom of the vein where the cutting is done, sharp rolls in the floor causing the cutting to be done in the very hard material of which these rolls are composed, and where the roof is bad enough to require the props to be set very close to the



face of the coal, thus not allowing enough room in which to work the machine. Also, when the inclination of the vein exceeds 12 or 15 degrees, the use of chain machines is impossible. Even at a dip of 12 degrees, working with a chain machine is frequently difficult and unsatisfactory. To obtain the best results, the floor should be level or nearly so.

In some cases pick machines have been used in mines having a dip of 23 degrees, but the work was slow and difficult, and only the high price of labor made them profitable. Manufacturers do not care to run the risk of failure in installing machines in mines having an inclination of 15 degrees. The first two conditions mentioned militate against the use of the chain machine, in that the cutters are not capable of disintegrating the material, and either break or are ground off; after the cutters are incapable of cutting, the machine is fed into the material with such force that great strains and stresses are thrown on the various parts of the machine, and unless care is exercised by the runner, damage will be done. While the above conditions may exist to some extent in any mine, it does not necessarily follow that the simple fact of their occurrence decides the question of mining by machines, and before deciding whether or not machine mining is practical, a careful investigation should be made by one who is familiar with the use of machines.

Where most of the mining is done on pillars, as in old workings, the chain cutter is seldom used. The great weight on the coal presses it down upon the machine, and after having made a cut it may not be possible to withdraw, in which case it is necessary to dig the sliding frame of the machine out with a pick. There is also danger of damaging the machine when using it for this kind of work. Under these conditions, it is more economical to use the pick machine or mine by hand. A similar objection works against the chain-breast machines for longwall mining, as too much space is required for them between the gob and the face of the coal. With a wide space between the gob and the face, the pressure of the roof is apt to squeeze the coal and wedge the machine.

**WORKING CAPACITY OF CHAIN CUTTERS.**

**19.** As the conditions under which a machine is operating determines the amount of work which it can do, it is possible to give but an approximate idea of the capacity of one of these machines. It is safe to say that where the chain machine can be used it will make from 30 to 40 cuts per day, each cut being 44 inches wide and 5, 6, or 7 feet deep. Allowing for lap in cuts, this would amount to from 100 to 150 lineal feet along the face, or from 500 to 1,000 square feet undercut. The record for cutting with a machine of the chain type is 104 cuts 6 feet deep in 9 hours and 40 minutes, the distance cut along the face being 333 lineal feet. In doing this work, the machine was moved six times and cut both rooms and narrow places.

---

**LONGWALL MINING MACHINE.**

**20.** Mining by machinery having been adopted so extensively has been the cause of developing machines adapted to each system. The longwall system of mining by hand has proved itself to be the most economical where the conditions are such that this system can be followed. Being the most economical to work by hand, the longwall system would naturally offer advantages to machinery which was particularly adapted for it, and a study of this system has developed a machine of the longwall type. The time required to shift a machine of the chain-breast type is so great that one of this kind could not be used, and a machine so constructed that it could cut continually along the face was designed.

**21.** Fig. 11 shows one of these machines. As will be observed, it is very compact, and is so constructed that maximum strength is contained in minimum space. The machine consists essentially of three parts: the motor, driving mechanism, and feeding gear. These are mounted upon two cast-steel angles, which run the entire length of the machine. The motor is bolted to the angles in the middle,

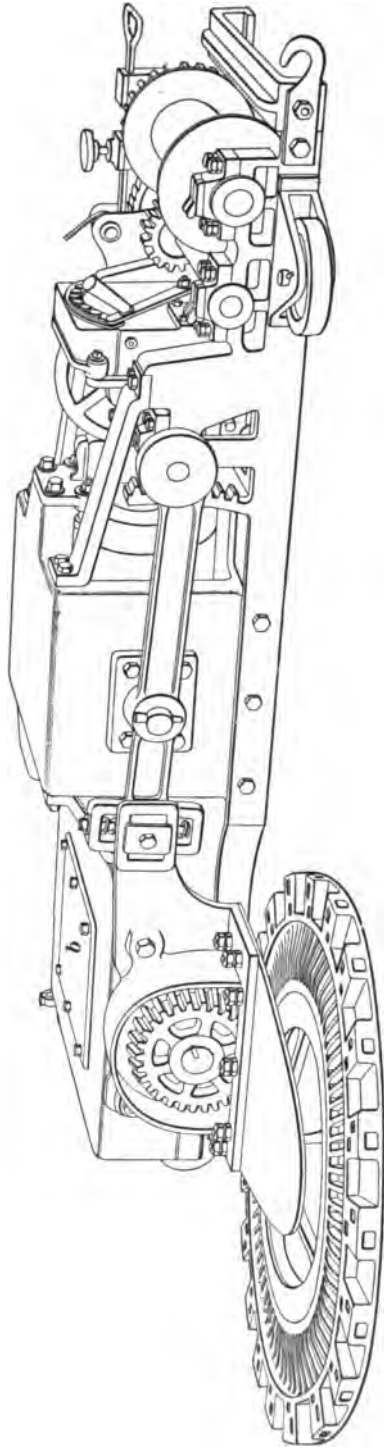

FIG. 11.

the driving mechanism is at one end, and the feeding gear at the other; these are further held together by braces, so that the machine is thoroughly strengthened throughout. At the front left-hand corner of the machine is located the cutter wheel. This is made of malleable iron, cast so that the teeth in which the driving pinion meshes form a part of its periphery; outside of these teeth are the heavy lugs in which the cutters are inserted. The wheel is supported by a heavy steel plate projecting from and bolted to the main portion of the machine.

The motor is of the multipolar type, having an iron-clad armature and two field coils. The armature lies in a position parallel to the length of the machine. A bevel pinion on the end of the armature shaft meshes with a large bevel-gear, which is mounted on a shaft at right angles to the armature shaft and which carries a bevel pinion meshing in the teeth of the large cutter wheel. On the same shaft at the opposite end is a pinion which meshes with a spur gear, driving a shaft to which is attached an eccentric. To this eccentric is attached a rod which passes along the side of the machine to a cross-head, to which is attached a connecting-rod driving a ratchet, which in turn drives a ratchet-wheel geared by a single reduction to a drum, upon which is wound a rope by which the machine is drawn or fed forwards.

The cutter wheels are built of different sizes to cut from 3 to 5 feet deep, the depth of cut depending entirely upon the conditions. The width over all of the machine when the cutter wheel is embedded in the coal is 3 feet 8 inches; its total length is 7 feet 9 inches; its total height is about 18½ inches.

The feeding mechanism, which has already been described, is variable, allowing the rate of winding the cable on the drum to be changed at will to 8, 16, or 25 inches per minute. The wire cable is run along the face of the coal as far as is desired, then passed around a sheave attached to a jack rigidly set between the roof and the floor, and then back to the machine, where it is hooked on the frame at the hook shown near the drum.

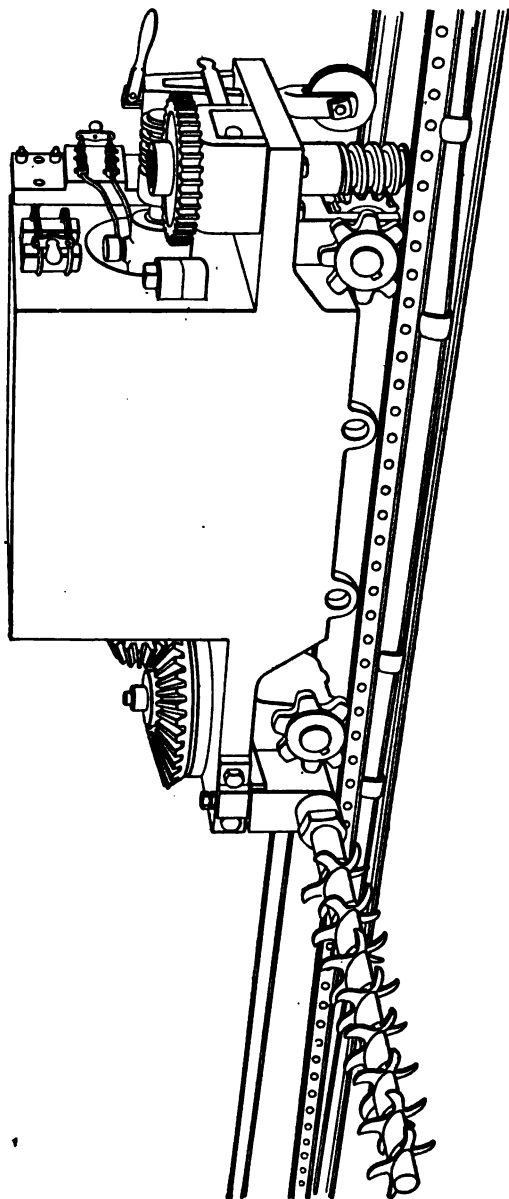

FIG. 12.

The cast-steel box *b* completely encases the gearing and is made oil-tight, so that the gears can be run in oil and any possibility of cutting avoided.

This machine, when in operation, is mounted on a single track or rail, and is known as the single-track type. The rail upon which it travels is held in place by suitably arranged jacks braced against the roof, and consists of two flat bars of iron, one 2 in.  $\times$   $\frac{1}{2}$  in. riveted upon the other, which is 4 in.  $\times$   $\frac{1}{2}$  in., the machine resting upon these by two flanged idlers, one at each end of the machine.

The operator, whose duty it is to see that the machine is working properly and to regulate the speed of feeding, can, by means of a hand-wheel, adjust the angle of the cutter wheel with respect to the horizontal, thus making it possible to cut close to the bottom and avoid any impurities which may be encountered, at the same time being able to follow the formation of the bottom or floor.

In addition to the operator, at least two men are required to lay track and remove obstructions.

This machine has been adopted to a limited extent in the United States and very generally abroad.

**22.** Another type of longwall machine which has recently been successfully introduced into some of the thin-vein mines of the Western fields is shown in Fig. 12. This machine has for its cutting mechanism an extension arm, around which is wound a spiral band of steel with 42 projecting teeth. In addition to cutting the coal, this spiral device acts as a screw conveyer in cleaning out the under cut. The arm can be turned on a pivot, so as to extend from the rear of the wheel for renewal of the spiral band and for starting the cut without recourse to hand picking. The motor is operated on a two-rail track, the rail next the coal being composed of two pieces of angle-bars held  $1\frac{1}{8}$  inches apart by shouldered rivets set at intervals of  $1\frac{1}{2}$  inches. This gives the effect of a rack bar, which meshes with the toothed wheels on that side of the motor. The outside rail and wheels are plain. By means of the handle shown above the right-hand upper

wheel, the cutting bar may be made to operate up or down from a horizontal plane, cutting over or under obstructions in the coal, and avoiding irregularities in the floor. Each outer wheel can be raised or lowered separately.

Two sets of rail are used, one being taken up and reset.

---

### THE CUTTER-BAR MACHINES.

**23.** The first electric chain-breast machine was put on the market in 1894, and almost simultaneously by three manufacturing concerns. Five years before, electricity had been successfully applied to a different type of coal-cutting machine, which had previously been operated solely by compressed air. This machine was what was known as the cutter bar. With the introduction of the chain-cutting machine, the cutter bar became obsolete and its manufacture abruptly ceased; but as some of these machines are still in operation in a few mines in the Western States, and as they mark an important step in the evolution of the successful machine, the student should have some knowledge of their construction.

The stationary frame of the cutter-bar machine was not materially different from that of the present chain machine, and the perfected type possessed a rack-and-pinion feed mechanism similar to that in use on the chain machines. The difference lay in the cutting mechanism itself and the direction of its movement. The cutting tool consisted of a rotating bar of steel extending across the forward end of the machine. The cutting teeth were inserted in its circumference, the second being slightly behind and a little to the side of the first, and so on, so that the line followed by the teeth was that of the thread of a screw. The bar was rotated by an endless chain driven by sprockets attached to the main driving shaft of the machine.

It will be observed that in this machine the coal was attacked in a direction at right angles to that of the chain machine. The power required to operate it was

considerably more than that necessary for the chain machine, its rapidity of cutting was less than the chain machine, and more difficulty was experienced in keeping the cut free of dirt. The first of these machines was made in 1876, the last one in 1894

---

**PICK MACHINES.**

**24.** In applying mechanical means for the production of coal, the natural form of machine was one built to attack the coal in a manner similar to that of the miner with his pick, and this idea eventually produced the machine which is commonly known as the "pick" or "puncher" machine, and which is the one that was first adopted for mining coal. The difficulty of transforming a rotary to a reciprocating motion has caused many of the efforts to build a practical electric pick machine to be unsuccessful; but such a machine has been built, and the following is a description of its working and construction. There is a wide field for electric machines of this type.

---

**DESCRIPTION OF A PICK MACHINE.**

**25.** Fig. 13 shows an electric pick machine which has a reciprocating piston actuated by a spring and cam, the spring striking the blow and the cam drawing the piston back. The cam is driven by a motor *m* of the toothed

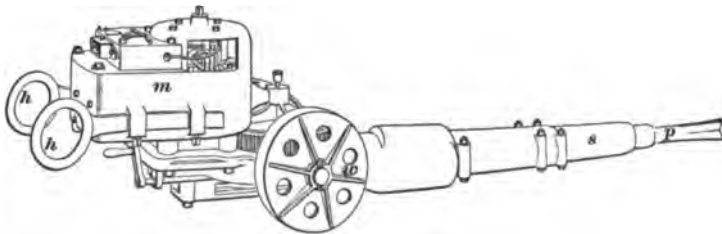

FIG. 13.

Gramme ring type. The important feature is the manner of connection of commutator to coils, there being no wire



connections at this point, which makes the armature as nearly indestructible as possible. The pick  $p$  is attached to the outer end of the piston, which is supported by the sleeve  $s$ .

The machine weighs 750 pounds and is mounted on wheels  $w$ . It is controlled, while working, by the handles  $h$ . Its length is 7 feet and its width over the wheels 21 inches. The piston makes from 175 to 225 8-inch strokes per minute.

#### METHOD OF OPERATING PICK MACHINES.

**26.** Fig. 14 shows a pick machine at work where props are set up close to the working-face. It will be noticed

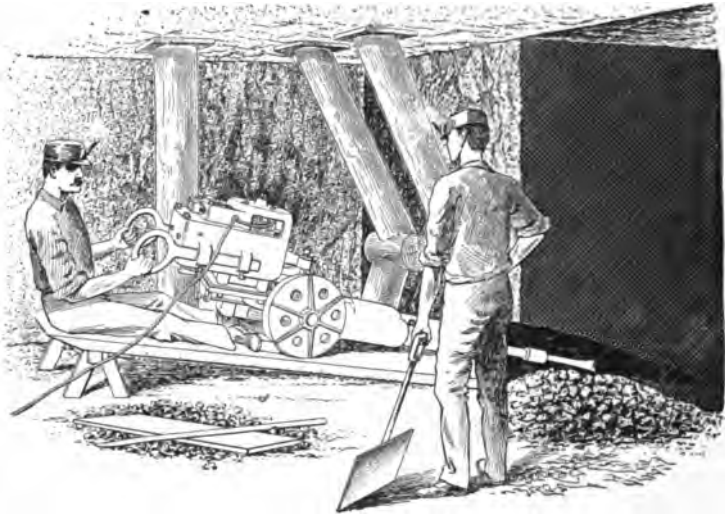

FIG. 14.

that the machine is placed upon a platform which is inclined towards the face, so as to neutralize the recoil of the machine by gravity and at the same time enable the operator to advance the machine easily as the cut deepens. The pick strikes from 175 to 225 blows per minute as desired, and while in operation the runner directs each blow by taking hold of both handles and sitting upon the platform just back

of the machine. When necessary he prevents the machine from running back by pushing a block of wood, or simply by placing the heel of his shoe, under one wheel with his foot. (He usually uses a wooden "chock" fastened to the bottom of his shoe.) Only two men are required to operate the machine, one skilled as runner and an ordinary laborer as helper, who shovels away the slack or cuttings from the machine and assists in placing the platforms. In order that the machine can be kept continuously at work, two platforms are used. While the one is in use the helper places the other one alongside of it, so that the operator can run the machine off the one on to the other whenever a cut is completed.

**27.** In making an undercut, the runner directs the machine so as to make a groove at the bottom of the coal about 1 foot deep and 3 or 4 feet along the face, according to the width of the platform and size of the machine. This groove is then enlarged by blocking down some of the coal, after which the same operation is repeated until the required depth is reached. When finished the front of the cut is about 12 inches high and the back about 2 inches high. This gives the cut a V shape, and causes the coal when blasted down with as light a charge of powder as possible to roll over in such a manner that the loaders can readily attack it.

**28.** Pick machines being mounted on wheels can easily be shifted or run from one room to another through the cross-cuts or break-throughs by the workmen, and in this respect they are more convenient than other types, which require mechanical means at all times to shift or transport them. Frequently, however, pick machines are run on to a truck for transportation.

**29.** Fig. 15 shows a pick machine mounted on large wheels for shearing or making vertical cuts in the coal. This machine is in all respects similar to the one already

described, except that the wheels *w* are 40 inches in diameter. It will shear  $4\frac{1}{2}$  feet deep and  $4\frac{1}{2}$  feet high, or higher, if the platform is placed on slack.

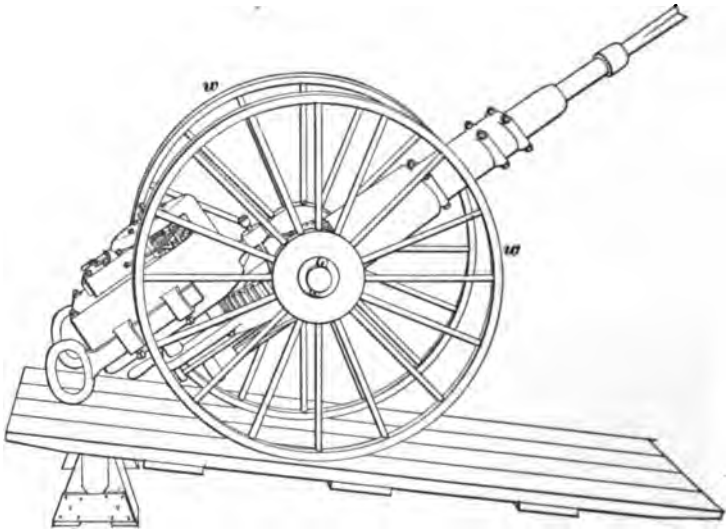

FIG. 15.

**30.** Fig. 16 shows a machine in position for making a shearing on one side of an entry. It will be noticed that the lower portion of the shearing is made wide enough for the wheels to enter. The operation of the machine for shearing is the same as for undercutting. The shearing is made after the undercut is finished by simply replacing the small wheels with the large ones and operating the machine to form a vertical cut, usually along the side, instead of a horizontal one along the bottom, as is done in regular undercutting. The truck *t* is used to carry the machine from place to place. It is more expensive to shear coal than to blast it, but more lump coal is produced with the shearer, and the air at the working-face is rendered impure by the gases formed by blasting.

**CONDITIONS FAVORABLE AND UNFAVORABLE TO  
PICK MACHINES.**

**31.** The pick machine can be used under all conditions favorable to mechanical methods of mining coal, and the only conditions which preclude its use where undercutting

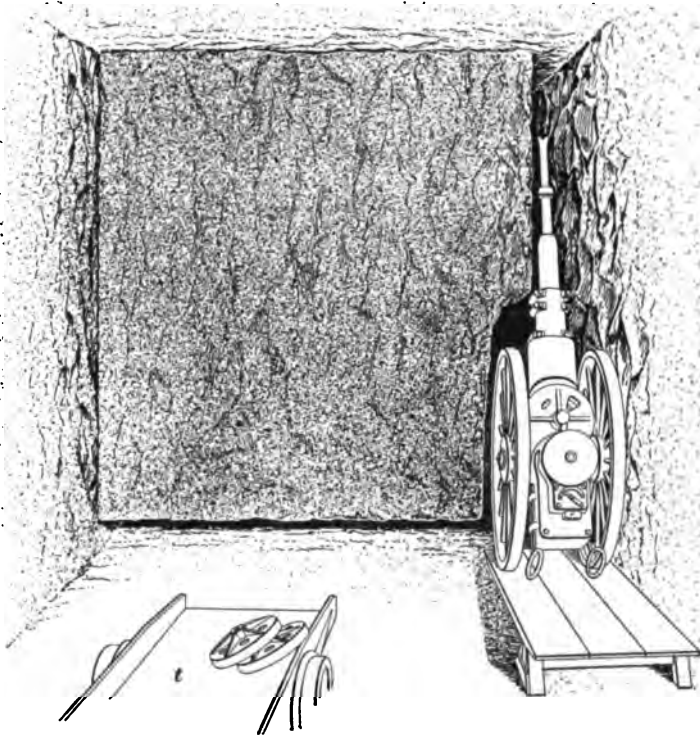

FIG. 16.

is necessary are too great a pitch, too low a seam, and bad roof where props must be set up close to the face and in great numbers. This latter condition affects the pick machine less than other types of coal-cutting machinery, as may be seen by referring to Fig. 14, where a machine is

shown at work among props and cockermegs used to support the undercut portion of the coal.

**32.** It can be seen from the construction and method of operating pick machines that they can cut the coal surrounding any hard foreign matter which may be embedded in the coal, and therefore remove such material without injury to the machine. For this reason pick machines are suitable for working seams of coal containing balls of iron pyrites, which will blunt or destroy any steel-cutting tool with which they come in contact. It is also evident that pick machines are suited to undercut coal on which there is a squeeze.

---

#### WORKING CAPACITY OF PICK MACHINES.

**33.** The amount of undercutting that can be done with any pick machine depends upon the lay and nature of the coal mined and the tact of the runner. A good electric pick machine will undercut about 450 square feet in 10 hours if handled properly, when a miner doing nothing else could undercut only about 120 square feet. In other words, pick machines will each cut from 50 to 100 tons of coal per day of 10 hours in seams varying in thickness from  $4\frac{1}{2}$  to 6 feet. The cost of cutting coal with pick machines in seams  $4\frac{1}{2}$  feet is approximately 10 cents per ton.

The figures given must not be confounded with phenomenal records which have been made, and which are the exception and not the rule. In Western Pennsylvania a compressed-air pick machine has undercut as much as 1,400 square feet in 9 hours, and in an 8-foot seam has mined as high as 240 tons per shift of 10 hours.

**34.** The student should carefully notice that the force with which the pick strikes depends upon the distance it penetrates the coal. For example, if the pick struck soft "mother coal" it would penetrate it for perhaps 1 foot, while if it struck hard rock it would only penetrate it for perhaps  $\frac{1}{4}$  of an inch. In either case the energy stored up

at impact would be given up in a distance equal to the depth of the cut, and therefore since it requires a greater resistance to stop the pick in  $\frac{1}{4}$  of an inch than in 1 foot, it is clear that the blow is much greater on the rock than on the mother coal, although the work done on each is the same.

**GENERAL REMARKS.**

**35.** Whatever the methods of undercutting, a greater proportion of lump coal will be obtained in the high seams, and for this reason the output of screened coal per machine

will be much greater in thick than in thin veins. But the increased cost of mining thin veins by hand makes the advantages of machine mining in thin veins much greater than in thick ones. It will be seen by referring to Fig. 17 that the amounts of coal made fine by undercutting in two seams *A* and *B* are equal, because the undercuts are the same size, which is generally so in practice. It is best to

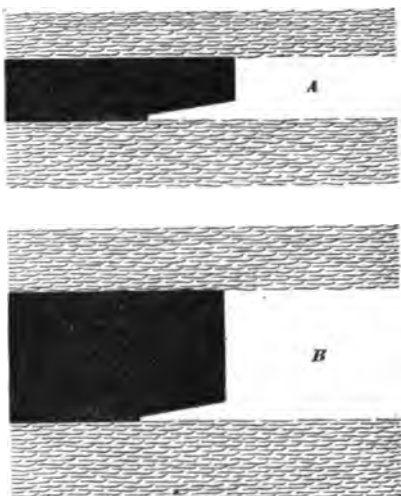

**FIG. 17.**

undercut a seam of coal at least to a depth equal to its height, in order to get the best results from blasting. When this is done and the undercuts are V shaped, as shown, the ratio of the small coal to the lump is approximately the same for all seams.

**36.** From the foregoing it will be plainly seen that each mine must adopt the machinery which is especially suited to its conditions and that there is hardly a mine to which some form of machine can not be applied. Where it is

### 34 ELECTRIC COAL-CUTTING MACHINERY. § 33

possible to have a long working-face, it is more economical to take advantage of this feature, as the machine can be kept constantly at work and less time consumed in moving. But where this can not be done, it simply remains to select the best form of machine for the conditions. There is no doubt that future methods of working coal will be modified to suit mechanical mining, for even with the present methods, mechanical mining has proved to be economical, and with the perfection which has been reached in the construction of machinery for this purpose, it is safe to predict that great reductions in the cost of production will be made in the future by the adoption of new methods of mining and the construction of new machinery.

# INDEX

---

NOTE.—All items in this index refer first to the section and then to the page of the section. Thus, "Acceleration, 6 5" means that acceleration will be found on page 5 of section 6.

<b>A</b>	<i>Sec.</i>	<i>Page</i>		<i>Sec.</i>	<i>Page</i>
Abandoned workings, Ap- proaching.....	14	48	Air, Splitting the.....	6	49
Absolute zero.....	5	26	" Velocity of.....	6	12
Acadian coal field.....	11	45	" Weight of.....	5	15
Accelerating force.....	6	5	Airway, Main.....	6	54
Acceleration.....	6	5	" Measuring resistance of.....	7	53
Accurate survey and map in coal prospecting.....	13	17	" Perimeter of.....	6	16
Acrogens.....	11	67	Alleghany area.....	11	44
Action of fans.....	7	41	Alternation of peat with sedi- ment.....	11	43
Advantage of heavy rails.....	31	31	American coal fields of the car- boniferous age.....	11	44
Advantages of electric loco- motives.....	31	35	Ammonite.....	5	56
" of electric pump- ing.....	33	3	Amphibians.....	11	67
Affinity.....	5	5	Analyses of coal, Examples of	12	45
After-damp.....	5	30	" of coal, Examples of	12	47
Age, Archean, or Eozoic.....	11	29	Analysis of coal.....	12	43
" of acrogens (Geology).....	11	29	Anemometer.....	7	54
" of acrogens (Geology).....	11	37	Annunciator, Use of.....	32	25
" of amphibians.....	11	29	Anthracite, Change from wood to.....	11	43
" of amphibians.....	11	37	" coal.....	11	62
" of fishes.....	11	29	Anticlinal axis or saddle.....	11	8
" of fishes.....	11	35	Anticline.....	11	8
" of invertebrates.....	11	29	Antiseptic.....	11	67
" of mammals.....	11	29	Approaching abandoned work- ings.....	14	48
" of man.....	11	29	Araucarian.....	11	67
" of mollusks.....	11	29	Arborescent.....	11	67
" of reptiles.....	11	29	Arc lamps, Enclosed.....	32	49
" of reptiles.....	11	51	" lamps on constant-poten- tial circuits.....	32	53
Air.....	5	15	" lamps, Open.....	32	41
" column.....	7	59	Arch template.....	13	76
" Density of.....	5	19	Archean age.....	11	29
" discharged, Quantity of.....	6	26	Arched roadways for mines... ..	13	75
" passages, Size of.....	7	49	Arenaceous rocks.....	11	3
" required in mines, Quantity of.....	7	48			



	<i>Sec.</i>	<i>Page</i>		<i>Sec.</i>	<i>Page</i>
Argillaceous rocks.....	11	4	Branch block.....	22	56
Articulates.....	11	67	Break, Line of.....	15	8
Ascensional ventilation.....	7	61	"    Line of.....	15	11
Ash in coal.....	12	46	"    throughs.....	14	21
Ashworth - Hepplewhite - Gray safety-lamp.....	5	70	Breaking of coal, Conditions affecting.....	15	6
Atmosphere, Composition of the.....	5	15	Breasts.....	14	21
Atmospheric pressure.....	5	20	"    Methods of opening and working.....	14	22
Atomic volume.....	5	11	Brick walling.....	13	76
"    weight.....	5	8	Bricks for shaft lining.....	13	22
Atoms.....	5	5	"    for shaft lining.....	13	23
Attraction.....	5	5	"    Number of.....	13	25
".....	5	14	Bridge for airway.....	6	54
			"    for airway.....	7	50
<b>B</b>	<i>Sec.</i>	<i>Page</i>	British thermal unit.....	5	14
Back breast.....	14	40	Brown coal or lignite.....	11	64
Barometer.....	5	18	"    rocks.....	12	15
"    Aneroid.....	5	18	Bryozoans.....	11	67
"    Mercurial.....	5	18	Buntons.....	13	11
Barrande's table.....	11	24	Buhrstone.....	11	67
Barrier pillars.....	14	47	Butt cleat.....	11	19
Basin.....	11	24			
Battery, Working on.....	14	22	<b>C</b>	<i>Sec.</i>	<i>Page</i>
Bearing in.....	15	13	Cables, Carrying capacity of..	22	49
Bedding plane.....	11	19	Caking coal.....	11	63
Beekman friction clutch.....	31	19	Calamite.....	11	68
Bellite.....	5	56	Calcareous rocks.....	11	4
Bells, Methods of connecting..	22	19	Calcite.....	11	65
"    Signaling with.....	22	18	Calculations for wiring.....	22	50
"    Single-stroke.....	22	21	Calorific power of coal.....	12	48
Bench.....	12	7	Cannel or parrot coal.....	11	63
Bituminous coal.....	11	62	Cambrian rock.....	11	20
Black damp.....	5	20	Capell fan.....	7	47
"    damp, Detection of... ..	5	26	Carbon in coal, Fixed.....	12	46
"    damp, Occurrence of... ..	5	25	Carbonate of calcium.....	11	65
"    damp, Properties of.....	5	26	Carbonic-acid gas.....	5	20
"    powder.....	5	48	"    oxide gas.....	5	20
"    rocks.....	12	14	Carboniferous age.....	11	27
"    rocks.....	12	15	"    age, American coal fields of the.....	11	44
Blasting apparatus, Electric... ..	13	40	Carrying capacity of cables... ..	22	49
"    by fuse.....	13	23	"    capacity of fuse wires.....	22	56
"    Electric.....	13	26	"    capacity of wires... ..	21	14
"    powder.....	5	48	Causes of ignition in mine ex- plosion.....	5	59
Blind pit.....	15	31	Cement tubing.....	13	26
Blossom, Coal.....	12	8	Cenozoic era.....	11	23
Blowers.....	5	39	Center of gyration.....	7	40
Blown-out shot.....	5	50	"    packed pump.....	22	9
Blue rocks.....	12	15	Centigrade scale.....	7	58
Bony coal.....	11	26	Centrifugal force.....	7	25
Boring.....	12	29	"    pump.....	22	4
"    Classification of.....	12	33	Centripetal force.....	7	25
"    methods.....	12	31			
Boss, Fire.....	5	74			
Brachiopods.....	11	67			
Brattice.....	7	50			

	<i>Sec.</i>	<i>Page</i>		<i>Sec.</i>	<i>Page</i>
Cephalopods.....	12	21	Coal cutting machines, Chain		
Chain coal-cutting machines...	33	5	type.....	33	5
" coal-cutting machines,			" Determination of quan-		
Conditions favorable			tity and quality of.....	12	48
and unfavorable to....	33	19	" dust.....	5	60
" coal-cutting machines,			" Evidences of.....	12	5
Methods of operating			" Evidences of.....	12	10
and handling.....	33	11	" fields of Carboniferous		
" coal-cutting machines,			Age.....	11	44
Trucks for.....	33	14	" flora.....	11	47
" cutters, Working capaci-			" formations, Disturbance		
ty of.....	33	21	of.....	12	12
" shearing machines.....	33	15	" measure topography.....	12	7
Chalk.....	11	66	" measures, Barren.....	11	40
Chamber method.....	14	1	" measures, False.....	11	37
Chambers.....	14	21	" measures, Lower.....	11	40
" Methods of opening			" Metamorphic.....	11	42
and working.....	14	28	" Mode of growth of.....	11	40
Change of dip.....	12	13	" Non-caking.....	11	63
" of outcrop.....	12	21	" period, Climate of.....	11	60
Check battery.....	14	33	" Presumptive evidence of		
" battery.....	14	35	Sampling of.....	12	43
Chemical compound.....	5	6	" seams.....	11	58
" equations.....	5	11	" seams, Thickness of.....	11	58
" reactions.....	5	47	" Search for, First stage in	12	4
" symbols.....	5	10	" Search for, Second stage		
Chemistry.....	5	1	in.....	12	6
Chocks.....	15	1	" Source of.....	11	40
Churn drill.....	13	30	" Varieties of.....	11	46
Circular mill, Definition of.....	32	46	" Varieties of.....	11	62
" shafts.....	13	17	" Weight of.....	12	51
Clanny safety lamp.....	5	66	Coccoliths.....	11	4
Classification of boring.....	12	33	Coccospheres.....	11	68
Clay ironstone.....	11	68	Cockermegs.....	15	38
" veins.....	11	23	Coefficient of friction.....	6	22
Cleats.....	11	19	Cofferdam.....	13	11
".....	15	4	Coking coal.....	12	49
Cleavage, Cone-in-stone.....	11	19	Color of rocks.....	12	14
Climate of coal period.....	11	60	Column of air, Motive.....	7	7
Clinometer.....	11	68	" of air, Motive.....	7	61
Closer.....	13	17	Columnar.....	11	68
Coal analyses, Examples of....	12	45	Combustible matter in coal,		
" analyses, Examples of....	12	47	Volatile.....	12	46
" Analysis of.....	12	43	Combustion, Active.....	5	45
" bearing strata, Determi-			" Slow.....	5	45
nation of.....	12	5	" Spontaneous....	5	46
" beds, Continuity of.....	12	17	" Temperature of..	5	45
" blossom.....	12	8	Comparison of systems of		
" Brown.....	11	64	pumping.....	32	2
" Caking.....	11	63	Composition of coal..	11	64
" Calorific power of.....	12	48	" of coal.....	12	45
" Cannel or parrot .....	11	63	Compound, Chemical.....	5	6
" Coking.....	12	49	Concretions.....	11	10
" Composition of.....	11	64	Conditions favorable and un-		
" cutting, General remarks			favorable to chain coal-cut-		
on.....	33	33	ting machines.....	33	19

	<i>Sec.</i>	<i>Page</i>		<i>Sec.</i>	<i>Page</i>
Conditions favorable and unfavorable to pick machines..	33	31	Cutter-bar machines.....	33	26
Conducting the air-current...	7	49	" chain, Construction of	33	10
Conduction of air in mine ventilation.....	7	48	" or trepan.....	13	54
Conductors.....	13	64	Cycads.....	11	69
" Materials for.....	22	46			
Conformity of strata.....	11	10	<b>D</b>	<i>Sec.</i>	<i>Page</i>
Congener.....	11	68	Dams.....	14	76
Conglomerates.....	11	3	" Construction of.....	14	78
".....	11	4	" Cylindrical.....	14	82
Conifers.....	11	68	" cylindrical, Rules for thickness of.....	14	84
Construction of cutter chain...	33	10	" Location of.....	14	77
" of mine locomotives.....	31	26	" Requirements of.....	14	77
Contiguous seams, how worked.....	14	45	" Spherical.....	14	81
" seams, Order of working.....	15	14	" spherical, Rules for thickness of.....	14	84
Continuity of coal beds.....	12	17	" Use of.....	14	76
Control of lights from two or more points.....	32	60	" Wedge-shaped.....	14	79
Copper wire, Properties of.....	22	48	Danger of injury from shock..	31	15
Coral limestone.....	11	66	Day drift.....	12	55
" reef-building.....	11	5	Debituminization.....	11	46
Cornish pumping engine.....	12	40	Debris.....	11	69
Crater of volcano.....	11	14	Deepening shafts.....	12	62
Creep, how confined.....	14	18	Deflagration.....	5	47
" how prevented.....	14	18	Deflector, Howat's.....	5	70
" how prevented.....	15	61	Delta.....	11	69
" in longwall.....	15	61	Density of air, how measured	7	57
Cretaceous Age.....	11	51	Denudation.....	11	22
" Age.....	11	54	".....	11	24
" strata.....	11	54	Description of pick machines	33	27
Crinoids.....	11	4	Details, Record of.....	12	31
Cross latch.....	14	64	Determination of coal-bearing strata.....	12	5
" section of wires, Estimation of.....	22	46	" of underground curve.....	12	29
Crush.....	14	18	Detonating explosives.....	5	52
Crustaceans.....	11	68	Detonation.....	5	47
Crystalline.....	11	69	Detritus.....	11	69
Curbs.....	13	19	Devonian system.....	11	35
".....	13	22	Diamond drill.....	13	31
".....	13	24	Diffusion.....	5	37
".....	13	26	" Rate of.....	5	37
" Supporting.....	13	24	Dip.....	11	7
" Uses of.....	13	26	" Change of.....	12	13
Current, Conducting the.....	7	49	" Direction of.....	12	8
" consumption of incandescent lamps.....	32	41	" faults.....	12	25
" motion, Laws of.....	7	2	" how found.....	12	33
" Velocity of.....	7	48	" True.....	12	13
" Ventilating.....	7	1	Direct-current hoist with jaw clutch.....	31	21
" Ventilating.....	7	3	Direction of dip.....	12	8
Curvature of strata.....	12	27	" of pillars.....	14	14
Cut-outs.....	32	54	Dislocations.....	11	22
			Dissociation.....	5	8
			Disturbance of coal formations	12	12

	<i>Sec.</i>	<i>Page</i>		<i>Sec.</i>	<i>Page</i>
Dome of subsidence.....	14	2	Electric pumps, General construction and form of packing employed in.....	32	4
Double-chute breasts.....	14	35	“ pumps, Steam consumption of.....	32	2
“ entry system.....	14	21	“ transmission at mines.....	31	3
Down-throw.....	11	21	“ transmission, Choice of system.....	31	4
Drainage of mines.....	33	1	“ transmission, Practical examples of.....	31	5
Drawing pillars.....	14	16	“ vs. rope haulage.....	31	27
“ timber.....	15	63	Electricity and compressed air, Relative advantages of.....	31	2
Drift.....	13	79	Elements.....	5	5
“ Day.....	12	55	Enclosed arc lamps.....	33	42
“ Location of.....	13	90	“ sinking pump.....	32	13
Drill, Churn.....	13	30	Encrinites.....	11	69
“ Diamond.....	13	31	English longwall system.....	15	31
“ Hand.....	13	33	“ longwall system.....	15	34
“ Percussion.....	13	33	“ longwall system.....	15	36
Drilling for shaft sinking.....	18	29	“ longwall system.....	15	40
Drum method of shaft sinking.....	13	45	“ longwall system.....	15	55
“ Iron.....	13	47	Entering a mine after explosion.....	7	67
“ Wooden.....	13	45	Equations, Chemical.....	5	11
Dykes.....	11	69	Eozoic era.....	11	28
“.....	12	24	“ era.....	11	29
Dynamic geology.....	11	1	Eozoön Canadense.....	11	29
Dynamite.....	5	53	Epochs.....	11	28
“.....	13	41	“.....	11	69
	<b>E</b>		Equisetæ.....	11	70
Echinoderms.....	<i>Sec.</i>	<i>Page</i>	Era.....	11	70
Economic geology.....	11	1	“ Archean, or Eozoic.....	11	29
Effect of grade upon capacity of locomotives.....	31	30	“ Cenozoic.....	11	28
Electric blasting.....	13	36	“ Mesozoic.....	11	51
“ blasting apparatus.....	13	40	“ Paleozoic.....	11	30
“ coal-cutting machinery, General considerations.....	33	1	“ Psychozoic.....	11	28
“ haulage, General considerations.....	31	25	“ Prehistoric.....	11	28
“ hoisting, General considerations.....	31	15	Erosion.....	11	70
“ hoisting, Practical examples of.....	31	16	Escarpment.....	11	8
“ locomotive, Advantages of.....	31	25	“.....	11	10
“ locomotives, Effect of grade upon capacity.....	31	30	Estimation of cross-section of wire.....	32	46
“ locomotives, Examples of.....	31	33	Ethene.....	5	37
“ locomotives, Size and capacity of.....	31	37	Evan Thomas safety lamp.....	5	67
“ locomotives, Speed of.....	31	27	Evase chimney.....	7	43
“ locomotives vs. the mule.....	31	27	Evidences of coal.....	12	5
“ portable pump.....	32	16	Examples of electric locomotives.....	31	33
“ pumping, Advantages of.....	32	3	Explosion, Force of.....	5	41
“ pumps, Gearing for.....	32	5	“ in mines.....	5	57
			“ Temperature of.....	5	59
			“ To reduce the liability of.....	5	61
			Explosives.....	5	46
			“.....	13	40



	<i>Sec.</i>	<i>Page</i>		<i>Sec.</i>	<i>Page</i>
Geological fauna.....	11	12	Hydraulic limestone.....	11	68
"    flora.....	11	12	Hydrocarbons in coal.....	12	46
"    formation.....	11	10			
"    horizon.....	12	16	<b>I</b>	<i>Sec.</i>	<i>Page</i>
"    plan.....	12	20	Incandescent lamps.....	32	40
Geology, Divisions of.....	11	1	"    lamps, Voltage		
Geordy safety lamp.....	5	65	of.....	32	40
Glaciers.....	11	70	"    lighting by direct		
Glossary of geological terms..	11	67	current....	32	43
Gneiss.....	11	70	"    lighting with alternating		
Gobert method of shaft sinking	13	48	current.....	32	45
Grade crossings.....	14	68	Identification of rocks.....	12	14
Granular limestone.....	11	66	Igneous rocks.....	11	13
Graphite.....	11	71	Inclination of props.....	14	51
Grate surface.....	7	11	Inclined seams, Methods of		
Gravitation.....	6	1	working.....	14	25
"    Law of.....	6	2	Independent drum hoist with		
Gravity, Force of.....	6	1	induction motor....	31	23
"    Specific.....	12	50	Inducing currents, Systems of	7	1
Gray rocks.....	12	15	Injury from shock, Danger of	31	15
Green rocks.....	12	15	Insulation of transmission lines	31	8
Group.....	11	71	Interior and underground wiring		
Guibal fan.....	7	47	ing.....	31	10
Guide rods.....	13	11	Invertebrate.....	11	71
Guides (Sinking).....	13	64	Invertebrates, Age of.....	11	29
Gulf stream.....	11	71	Iron drums.....	13	47
Gunboat.....	14	74	"    guides.....	13	65
Guncotton.....	5	54			
Gyration, Center of.....	7	40	<b>J</b>	<i>Sec.</i>	<i>Page</i>
<b>H</b>	<i>Sec.</i>	<i>Page</i>	Joints in wires.....	32	49
Hade.....	11	21	"    of rocks.....	11	19
Hand drill.....	13	32	Jugulars.....	14	31
Hangers for trolley-wires.....	31	11	Jumpers.....	13	30
"    Methods of attaching,			Junctions in airway.....	6	55
to roof.....	31	12	Jurassic Age.....	11	51
Haulage block signal.....	32	35	"    strata.....	11	52
"    roads, Signal for.....	32	24	Jura-triassic Age.....	11	53
Heat unit.....	5	14			
Heaves.....	11	20	<b>K</b>	<i>Sec.</i>	<i>Page</i>
Heavy rails, Advantages of...	31	31	Kind-Chaudron system of shaft		
Heteropod.....	11	71	sinking.....	13	54
High explosives.....	13	40	Kuro-Shiwo.....	11	71
"    explosives, Properties of	13	43			
Historical geology.....	11	28	<b>L</b>	<i>Sec.</i>	<i>Page</i>
Hitches.....	11	20	Laccolite.....	11	71
Hoist, General Electric.....	31	17	Lambert hoist.....	31	23
"    Lambert.....	31	23	Lamellar.....	11	72
"    operated by induction			Lamellibrancha.....	11	72
motor.....	31	23	Lamination, Horizontal.....	11	6
Hoisting compartments, Width			"    how formed.....	11	6
of.....	13	6	"    Oblique.....	11	7
Holing.....	15	13	"    Oblique.....	12	13
Horizon, Geological.....	12	16	Landings, Slope.....	14	7
Horsepower.....	6	28	Laramie cretaceous.....	11	55
Howat's deflector.....	5	70	Laurentian system of rocks....	11	29



	<i>Sec. Page</i>		<i>Sec. Page</i>
Mica schist.....	11 78	Oblique lamination.....	12 18
Mil, Definition of.....	29 46	"    section.....	12 29
Mine locomotives, Construction of.....	31 26	Occluded gases, Pressure of...	5 39
Mines, Drainage of.....	29 1	Occlusion of gases.....	5 38
"    Electric transmission at	31 8	Olefiant gas.....	5 37
"    Long-distance transmission at.....	31 2	Olenellus.....	11 73
"    Power transmission at..	31 1	Oolyte, or roe stone.....	11 66
"    Testing for firedamp in	5 74	Opening and working breasts, chambers, and rooms, Methods of.....	14 28
Mine explosions.....	5 57	Openings, Location of permanent.....	13 53
"    explosions, Causes of ignition in.....	5 59	Operations in sinking.....	13 8
"    fires, their causes and treatment ..	7 68	"    in sinking.....	13 29
"    ventilation.....	6 1	Order of removing layers.....	15 49
"    ventilation, Quantity and velocity of air required in.....	7 48	"    of superposition.....	11 12
"    working, Longwall method of.....	15 1	"    of working seams.....	15 14
"    working, Methods of...	14 1	"    of working seams, Contiguous.....	10 14
Mining, Longwall methods of machines, Transmission of electrical energy to.....	33 2	Organism.....	11 73
Mixing gases.....	5 28	Origin of fossils.....	11 11
Mixture.....	5 6	Open-arc lamps.....	23 41
Mode of growth of coal.....	11 40	Operating and handling chain coal-cutting machines.....	23 11
Moisture in coal.....	12 45	Operation of reciprocating bell	23 20
Molecular force.....	5 14	Outbursts.....	5 40
"    weight.....	5 8	Outcrop.....	11 8
Molecules.....	5 5	"    .....	11 10
Mollusks, Age of.....	11 29	"    Change of.....	12 21
"    Age of.....	11 30	"    on plan, Breadth of...	12 16
Monkey gangway.....	14 45	Overlap.....	11 27
Monoclinal strata.....	11 9	"    fault.....	11 22
Monocline.....	11 8	Oxidation.....	5 45
Mortar.....	13 26	Oxonite.....	5 56
Motive column of air.....	6 13		
"    column of air.....	7 7	<b>P</b>	<i>Sec. Page</i>
Multiple-series system of incandescent lighting.....	22 44	Panel system.....	14 23
Mueseler safety lamp.....	5 69	Partial vacuum.....	5 17
		Partially enclosed sinking pump.....	23 12
<b>N</b>	<i>Sec. Page</i>	Pascal's law.....	6 56
Nips.....	11 22	Peat, Alternation of, with sediment.....	11 42
Nitroglycerine.....	5 53	Pentremites.....	11 73
"    explosives ..	13 40	Percussion drill.....	13 33
Nodules.....	11 10	Periclinal strata.....	11 9
Nogs.....	15 1	Pericline.....	11 8
Non-caking coal.....	11 63	Perimeter of airway.....	6 16
"    caking coal.....	12 50	Period.....	11 73
Notes of coal analysis.....	12 47	Permian period.....	11 50
"    Preservation of.....	12 19	Permo-Carboniferous.....	11 73
"    Prospecting.....	12 3	Pick machines.....	23 27
		"    machines, Conditions favorable and unfavorable to.....	23 31
		"    machines, Description of	23 27



	<i>Sec.</i>	<i>Page</i>		<i>Sec.</i>	<i>Page</i>
Pick machines, Methods of operating.....	33	28	Prismatic.....	11	73
" machines, Working capacity of.....	33	32	Process of sinking.....	13	29
Pieler safety lamp.....	5	71	Properties of copper wire.....	32	48
Piling method of sinking.....	13	43	Proportion of pillar to opening.....	14	14
Pillar and stall.....	14	23	Propping.....	14	49
" drawing.....	14	16	Props, Inclination of.....	14	51
" drawing.....	14	18	" Position of.....	14	49
" Proportion of, to opening.....	14	14	" Setting.....	14	51
Pillars, Barrier.....	14	47	" Throwing.....	15	65
" Direction of.....	14	14	Prospecting.....	12	1
" In main workings.....	14	18	" Approximate survey in.....	13	2
" Robbing or skipping... ..	14	18	" notes, how kept... ..	12	4
" Shaft.....	14	1	" notes, how kept... ..	12	19
" Shaft.....	15	2	" party.....	12	52
" Size of.....	14	4	" Preliminary consideration in.....	12	1
" Slope.....	14	5	" Preliminary work in.....	12	1
Pinch out.....	11	24	Prospector's map.....	12	19
Placoid.....	11	73	" map.....	12	3
Plan, Geological.....	13	20	Protection against short circuits.....	32	53
Plants found in coal beds.....	11	62	Protozoans.....	11	73
Plication.....	11	45	Psychozoic era.....	11	28
Plumbing the shaft while sinking.....	13	26	Pteropods.....	11	73
Plutonic rocks.....	11	16	Pump, Selection of.....	32	17
Pockets.....	11	24	" Single reduction geared.....	32	12
Poetsch method of shaft sinking.....	13	48	Pumping compartment, Width of.....	13	7
Point rods.....	13	64	Punch blocks.....	13	11
Polyps.....	11	73	Push-button, Ordinary style... ..	32	22
Port of entry.....	7	31	" button, Waterproof.....	32	38
" of ventilating fan.....	7	30			
Portable pump.....	32	16	<b>Q</b>	<i>Sec.</i>	<i>Page</i>
Position of props.....	14	49	Quantity of air discharged (mine ventilation).. ..	6	26
Post-and-bar system.....	14	56	" of air required in mine ventilation.....	7	48
Pot holes.....	11	26	Quaternary system.....	11	28
Potentite.....	5	55	Quicksands, Shaft sinking through.....	13	43
Powder, Black.....	5	48	" Shaft sinking through.....	13	48
" Blasting.....	5	48			
Power, Unit of.....	6	28	<b>R</b>	<i>Sec.</i>	<i>Page</i>
" transmission at mines.....	31	1	Rack-a-Rock.....	5	56
Practical examples of electric hoisting.....	31	16	Radiates.....	11	73
" problems in mine ventilation.....	6	44	Rails.....	14	62
Prehistoric eras.....	11	28	Reciprocating bell, Operation of.....	32	20
" eras.....	11	73	Record of details.....	12	31
Pressure, Ventilating.....	6	15	Rectangular shafts.....	13	5
Presumptive evidence of coal Preventing a thrust or creep.. ..	14	18	" shafts, Sinking... ..	13	8
Primary split.....	6	54	" shafts, Walling and timbering.. ..	13	9
" system.....	11	28			
Primer.....	13	35			
Prism.....	11	73			

	<i>Sec.</i>	<i>Page</i>		<i>Sec.</i>	<i>Page</i>
Reef-building corals.....	11	5	Roots and stumps in coal seams	11	11
Regulator for airway.....	6	54	Rope guides, Wire.....	13	66
"    for airway.....	6	50	Round iron guides.....	18	65
"    for airway.....	7	50			
Reopening.....	14	19	<b>S</b>	<i>Sec.</i>	<i>Page</i>
Reptiles, Age of (Geology)....	11	29	Sampling of coal.....	12	43
"    Age of (Geology)....	11	51	Safety lamp, Description of...	5	62
Resistance of airway, how			"    lamp, Illuminating		
measured.....	7	52	power of.....	5	72
"    to flow of air.....	6	34	"    lamp, Locks for.....	5	73
Retarding force.....	6	5	"    lamp, Oil used in.....	5	73
Return circuit for trolley			"    lamp, Principles of....	5	62
system.....	31	13	"    lamp, Requirements of		
"    Main.....	6	54	a good.....	5	64
Rhabdoliths.....	11	4	"    lamp, The Ashworth-		
Rhizopods.....	11	4	Hepplewhite-Gray...	5	70
Rider.....	13	16	"    lamp, The Clanny.....	5	66
Rings, Water.....	12	22	"    lamp, The Davy.....	5	64
Rise workings.....	7	60	"    lamp, The Evan Thomas	5	67
Roads, Underground.....	14	52	"    lamp, The Geordy....	5	65
"    Underground.....	14	61	"    lamp, The Marsaut....	5	68
Robbing pillars.....	14	18	"    lamp, The Mueseler....	5	69
Roburite.....	5	56	"    lamp, The Pieler.....	5	71
Rock-chute mining.....	14	42	"    lamp, The Stephenson	5	65
"    formations, groups, or			Schiele fan.....	7	46
systems.....	11	28	Scotch longwall system.....	15	57
"    slope.....	12	54	Seam, Opening out a.....	13	1
"    slope.....	12	56	"    Opening out a.....	13	2
Rocks, Arenaceous.....	11	3	Seams, Contiguous order of		
"    Argillaceous.....	11	4	working....	14	45
"    Black.....	12	14	"    Contiguous order of		
"    Black.....	12	15	working.....	15	14
"    Blue.....	12	15	"    Thickness of.....	11	58
"    Brown.....	12	15	Search for coal, First stage in	12	1
"    Calcareous.....	11	4	"    for coal, Second stage		
"    Calcareous, how formed	11	4	in.....	12	6
"    Color of.....	12	14	Section of rocks in Western		
"    Gray.....	12	15	Pennsylvania.....	11	39
"    Green.....	12	15	"    of rocks in Waynes-		
"    Identification of.....	12	14	burg, Pa.....	11	59
"    Igneous.....	11	13	"    table, Oblique.....	12	28
"    Laurentian system of..	11	29	Sections, Advantages of ma-		
"    Metamorphic.....	11	16	king (in mapping)	12	26
"    Plutonic.....	11	16	"    Horizontal.....	12	26
"    Smell of.....	12	16	"    Oblique.....	12	29
"    Stratified.....	11	3	"    of strata.....	12	27
"    Stratified.....	11	6	"    Vertical.....	12	26
"    Structure common to all	11	18	S�curite.....	5	56
"    Unstratified.....	11	13	Selection of pump.....	32	17
"    White.....	12	14	Series arc-light system.....	32	61
"    Yellow.....	12	16	Setting props.....	14	51
Roe stone or oolite.....	11	66	Shaft bottoms.....	14	7
Rolls.....	11	22	"    pillars.....	14	1
Room, Testing.....	15	62	"    pillars.....	15	2
Rooms, Methods of opening			"    pillars, Size of.....	14	4
and working.....	14	22	"    Signals in.....	32	29

	<i>Sec. Page</i>		<i>Sec. Page</i>
Shaft sinking through quick-sands, Drum method..	13 45	Sinking pump, Partially enclosed .....	32 12
“ sinking through quick-sands, Gobert method	13 48	“ rectangular shafts...	13 8
“ sinking through quick-sands, Piling method..	13 43	“ shafts, Plumbing while.....	13 26
“ sinking through quick-sands, Poetsch method	13 48	“ shafts through quick-sands .....	13 43
“ sinking through quick-sands, Triger's method	13 51	“ shafts through quick-sands .....	13 48
“ sinking through water..	13 54	“ shafts through water	13 54
“ Suspension of cables in	31 10	“ shafts through water, The Kind-Chaudron system .....	13 54
Shafts, Boring.....	12 29	“ shafts through water, The Lippman system .....	13 61
“ Circular .....	13 17	“ slopes.....	13 78
“ Deepening.....	13 62	Size and capacity of electric locomotives .....	31 27
“ Forms of.....	13 4	“ of air-passages.....	7 49
“ Location of.....	13 3	“ of pillars, Considerations governing .....	14 1
“ Rectangular .....	13 5	“ of pillars, Considerations governing .....	14 13
“ Rectangular, Sinking..	13 8	“ of powder grains .....	5 49
“ Rectangular, Walling and timbering.....	13 9	“ of shaft pillars, To calculate.....	14 5
“ Trial.....	12 29	Skipping pillars.....	14 18
“ Trial.....	12 37	Slant chutes.....	14 35
“ Ventilation of.....	13 16	“ chutes.....	14 37
“ Widening.....	13 63	Slides.....	13 64
Shale marl.....	11 66	Slip of blossom, Effect on coal bed .....	12 11
Shales .....	11 4	Slips or cleats, Forms of.....	11 19
“ .....	11 6	“ how produced.....	11 19
Shaly coal .....	11 46	Slope, Carriage.....	14 74
Shaw gas-testing machine...	5 76	“ landings.....	14 7
Shell limestone.....	11 66	“ pillars.....	14 5
Shingle.....	11 74	“ sinking.....	13 66
Short circuits, Protection against .....	32 53	“ sinking.....	13 78
Side timbers of shaft.....	13 11	“ timbering.....	13 66
Sides, Fast.....	15 3	Slopes.....	13 66
Sigillaria.....	11 74	“ Squeezes on.....	14 6
Signal system with telephones	32 31	“ Walling of.....	13 75
“ with ground connection	32 23	Smell of rocks.....	12 16
“ without ground connection.....	32 23	Snap switches.....	32 58
Signaling by flash-lights.....	32 30	Spathic iron ore.....	11 74
“ with bells.....	32 18	Special conditions in boring...	12 38
Signals for haulage roads.....	32 24	“ sinking devices.....	13 42
“ in shaft.....	32 29	“ shaft signal system....	32 37
Silica .....	11 74	Specific gravity .....	5 1
Silurian Age, Fossils of.....	11 35	“ gravity .....	12 50
“ system, Subdivisions of.....	11 30	“ gravity of coal.....	12 50
Single-reduction geared pump	32 12	Speed of electric locomotives.....	31 37
“ stroke bells.....	32 21	Split.....	6 49
Sinking devices, Special.....	13 42		
“ guides.....	13 15		
“ operations .....	13 8		
“ operations.....	13 29		
“ pump, Enclosed.....	32 13		

	<i>Sec.</i>	<i>Page</i>		<i>Sec.</i>	<i>Page</i>
Split, Main, primary, or first degree.....	6	54	Subsidence, Zone of.....	14	2
"    Secondary, or second degree.....	6	54	Substitute for timbers.....	13	26
"    Tertiary, or third degree.....	6	54	Sulphur in coal.....	11	64
"    Unequal.....	6	55	"    in coal.....	12	46
Splitting the air.....	6	49	Sulphureted hydrogen.....	5	30
"    Unequal.....	6	55	Superposition, Order of.....	11	12
Springs due to faults.....	12	25	Supporting curbs.....	13	24
Spontaneous combustion.....	7	68	Surface damages due to pillar drawing.....	14	17
Sprengel explosive.....	5	56	"    geology.....	11	1
Squeeze.....	11	24	Survey, Accurate (Prospecting)	12	17
"    on slopes.....	14	6	"    Approximate (Prospecting).....	12	2
Staggered props.....	15	12	Suspension of cables in shaft..	31	10
Stalactite.....	11	66	Switches.....	14	63
Stalagmite.....	11	66	Symbols, Chemical.....	5	10
Stall, Pillar and.....	14	23	Synclinal axis.....	11	8
Statuary marble.....	11	66	Syncline.....	11	8
Stemming.....	13	35	"    trough or basin.....	11	8
Stigmaria.....	11	74	System, Silurian.....	11	30
Steam consumption of electric pumps.....	32	2	Systems of lighting.....	32	43
"    consumption of steam pumps.....	32	2	"    of longwall.....	15	16
"    jet for ventilating.....	7	16	"    of pumping, Comparison of.....	32	2
"    pumps, Steam consumption of.....	32	2	"    Relative advantages of.....	15	16
Stink damp.....	5	30	<b>T</b>	<i>Sec.</i>	<i>Page</i>
Stone drift.....	14	44	T-iron rail guides.....	13	65
"    walling.....	13	23	Table, Barrande's.....	11	34
Stoppings.....	7	50	Talc schist.....	11	74
Strata, Archæan.....	11	29	Tamping.....	13	35
"    Coal-bearing.....	12	5	Temperature and volume.....	7	6
"    Cretaceous.....	11	55	"    of explosion.....	5	59
"    Curvature of.....	12	27	Templet for arch.....	13	75
"    Devonian.....	11	35	Tension of gases.....	5	21
"    Dip of.....	11	7	Terrace.....	12	7
"    Elevated.....	11	7	Tertiary fossils.....	11	57
"    Folded.....	11	7	"    system.....	11	28
"    Inclined.....	11	7	Testing by lamp in mines.....	5	75
"    Jurassic.....	11	53	"    by machine.....	5	75
"    Monoclinical.....	11	9	"    mines for firedamp... ..	5	74
"    Periclinal.....	11	9	"    the roof.....	15	62
"    Section of.....	12	27	Thermometer.....	7	57
"    Silurian.....	11	30	Thickness of coal seams.....	11	58
"    Strike of.....	11	7	"    of dams, Rules for.. ..	14	84
"    Thinning away of.....	11	27	Thinning out of coal seam.....	11	23
Stratified rocks.....	11	3	Throat of ventilating fan.....	7	31
"    rocks.....	11	6	Throwing the props.....	15	65
Streak.....	12	14	Throws.....	11	20
Strike faults.....	12	25	Thrust and creep.....	14	18
"    of strata.....	11	7	"    and creep, how prevented.....	14	18
Structural geology.....	11	1	"    faults.....	12	26
Subcarboniferous system.....	11	37	Timber drawing.....	15	63
Subsidence, Dome of.....	14	2	"    drawing, Tools used in	15	64
"    of roof seams.....	14	1			



	<i>Sec.</i>	<i>Page</i>		<i>Sec.</i>	<i>Page</i>
Water ring.....	13	23	Work.....	6	28
Wedging curb.....	13	19	Working capacity of chain cut-		
Weight, Atomic.....	5	8	ters.....	33	21
"    Laws of.....	6	2	"    capacity of pick ma-		
"    Molecular.....	5	8	chines.....	33	32
"    of air.....	5	15	"    contiguous seams....	14	45
"    of coal.....	12	51	"    face, Direction of....	15	4
"    of gas, how calculated	5	43	"    face, Form of.....	15	7
Western coal fields.....	11	44	"    methods, "End on".....	15	7
White damp.....	5	30	"    methods, "Face on".....	15	7
"    damp, how detected....	5	35	"    methods, "Half on".....	15	8
"    damp, Occurrence of....	5	34	"    methods, "Long		
"    damp, Properties of....	5	34	horn".....	15	8
"    rocks.....	12	14	"    methods, "Short		
Widening shafts.....	13	63	horn".....	15	8
Winding compartment, Size of	13	6	"    on battery.....	14	32
Windy shot.....	5	50	"    seams, Order of.....	14	45
Wire-rope guides.....	13	66	"    seams, Order of.....	15	14
Wires, Carrying capacity of...	31	14	Workings, Approaching abandon-		
"    Making joints in.....	32	49	ed.....	14	48
Wiring calculations.....	32	50			
Wood, Change of, to anthracite	11	43	<i>Z</i>	<i>Sec.</i>	<i>Page</i>
"    walling.....	13	22	Zero, Absolute.....	5	26
Wooden drum.....	13	45	Zone of subsidence.....	14	2
"    guides.....	13	64	Zoophytes.....	11	74

