

UC-NRLF

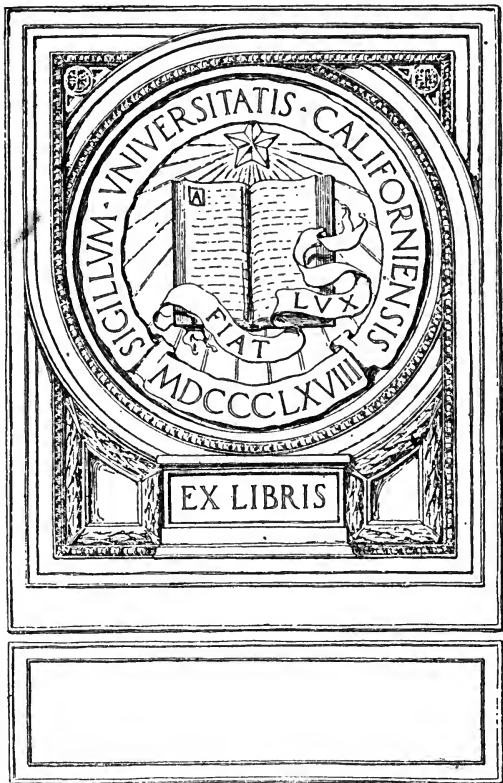

LB 278 207

GIFT OF



EX LIBRIS

get Elements

Digitized by the Internet Archive  
in 2007 with funding from  
Microsoft Corporation

4200  
INTRODUCTION TO  
ANALYTIC GEOMETRY

BY

PERCEY F. SMITH, PH.D.

PROFESSOR OF MATHEMATICS IN THE SHEFFIELD SCIENTIFIC SCHOOL  
YALE UNIVERSITY

AND

ARTHUR SULLIVAN GALE, PH.D.

ASSISTANT PROFESSOR OF MATHEMATICS IN  
THE UNIVERSITY OF ROCHESTER



GINN & COMPANY

BOSTON · NEW YORK · CHICAGO · LONDON

65.8

COPYRIGHT, 1904, 1905, BY  
**ARTHUR SULLIVAN GALE**

---

**ALL RIGHTS RESERVED**

65.8

THE  
ATHENAEUM  
PRESS

**The Athenaeum Press**  
GINN & COMPANY · PRO-  
PRIETORS · BOSTON · U.S.A.

## PREFACE

In preparing this volume the authors have endeavored to write a drill book for beginners which presents, in a manner conforming with modern ideas, the fundamental concepts of the subject. The subject-matter is slightly more than the minimum required for the calculus, but only as much more as is necessary to permit of some choice on the part of the teacher. It is believed that the text is complete for students finishing their study of mathematics with a course in Analytic Geometry.

The authors have intentionally avoided giving the book the form of a treatise on conic sections. Conic sections naturally appear, but chiefly as illustrative of general analytic methods.

Attention is called to the method of treatment. The subject is developed after the Euclidean method of definition and theorem, without, however, adhering to formal presentation. The advantage is obvious, for the student is made sure of the exact nature of each acquisition. Again, each method is summarized in a rule stated in consecutive steps. This is a gain in clearness. Many illustrative examples are worked out in the text.

Emphasis has everywhere been put upon the analytic side, that is, the student is taught to start from the equation. He is shown how to work with the figure as a guide, but is warned not to use it in any other way. Chapter III may be referred to in this connection.

The object of the two short chapters on Solid Analytic Geometry is merely to acquaint the student with coördinates in space

and with the relations between surfaces, curves, and equations in three variables.

Acknowledgments are due to Dr. W. A. Granville for many helpful suggestions, and to Professor E. H. Lockwood for suggestions regarding some of the drawings.

NEW HAVEN, CONNECTICUT  
January, 1905



# CONTENTS

## CHAPTER I

### REVIEW OF ALGEBRA AND TRIGONOMETRY

SECTION	PAGE
1. Numbers . . . . .	1
2. Constants . . . . .	1
3. The quadratic. Typical form . . . . .	2
4. Special quadratics . . . . .	4
5. Cases when the roots of a quadratic are not independent . . . . .	5
6. Variables . . . . .	9
7. Equations in several variables . . . . .	9
8. Functions of an angle in a right triangle . . . . .	11
9. Angles in general . . . . .	11
10. Formulas and theorems from Trigonometry . . . . .	12
11. Natural values of trigonometric functions . . . . .	14
12. Rules for signs . . . . .	15
13. Greek alphabet . . . . .	15

## CHAPTER II

### CARTESIAN COÖRDINATES

14. Directed line . . . . .	16
15. Cartesian coördinates . . . . .	17
16. Rectangular coördinates . . . . .	18
17. Angles . . . . .	21
18. Orthogonal projection . . . . .	22
19. Lengths . . . . .	24
20. Inclination and slope . . . . .	27
21. Point of division . . . . .	31
22. Areas . . . . .	35
23. Second theorem of projection . . . . .	40

## CHAPTER III

SECTION	THE CURVE AND THE EQUATION	PAGE
24.	Locus of a point satisfying a given condition . . . . .	44
25.	Equation of the locus of a point satisfying a given condition . . . . .	44
26.	First fundamental problem . . . . .	46
27.	General equations of the straight line and circle . . . . .	50
28.	Locus of an equation . . . . .	52
29.	Second fundamental problem . . . . .	53
30.	Principle of comparison . . . . .	55
31.	Third fundamental problem. Discussion of an equation . . . . .	60
32.	Symmetry . . . . .	65
33.	Further discussion . . . . .	66
34.	Directions for discussing an equation . . . . .	67
35.	Points of intersection . . . . .	69
36.	Transcendental curves . . . . .	72

## CHAPTER IV

## THE STRAIGHT LINE AND THE GENERAL EQUATION OF THE FIRST DEGREE

37.	Introduction . . . . .	76
38.	The degree of the equation of a straight line . . . . .	76
39.	The general equation of the first degree, $Ax + By + C = 0$ . . . . .	77
40.	Geometric interpretation of the solution of two equations of the first degree . . . . .	80
41.	Straight lines determined by two conditions . . . . .	83
42.	The equation of the straight line in terms of its slope and the coördinates of any point on the line . . . . .	86
43.	The equation of the straight line in terms of its intercepts . . . . .	87
44.	The equation of the straight line passing through two given points . . . . .	88
45.	The normal form of the equation of the straight line . . . . .	92
46.	The distance from a line to a point . . . . .	96
47.	The angle which a line makes with a second line . . . . .	100
48.	Systems of straight lines . . . . .	104
49.	The system of lines parallel to a given line . . . . .	107
50.	The system of lines perpendicular to a given line . . . . .	108
51.	The system of lines passing through the intersection of two given lines . . . . .	110

## CHAPTER V

THE CIRCLE AND THE EQUATION  $x^2 + y^2 + Dx + Ey + F = 0$ 

SECTION	PAGE
52. The general equation of the circle . . . . .	115
53. Circles determined by three conditions . . . . .	116
54. Systems of circles . . . . .	120

## CHAPTER VI

## POLAR COÖRDINATES

55. Polar coördinates . . . . .	125
56. Locus of an equation . . . . .	126
57. Transformation from rectangular to polar coördinates . . . . .	130
58. Applications . . . . .	132
59. Equation of a locus . . . . .	133

## CHAPTER VII

## TRANSFORMATION OF COÖRDINATES

60. Introduction . . . . .	136
61. Translation of the axes . . . . .	136
62. Rotation of the axes . . . . .	138
63. General transformation of coördinates . . . . .	139
64. Classification of loci . . . . .	140
65. Simplification of equations by transformation of coördinates . . . . .	141
66. Application to equations of the first and second degrees . . . . .	144

## CHAPTER VIII

## CONIC SECTIONS AND EQUATIONS OF THE SECOND DEGREE

67. Equation in polar coördinates . . . . .	149
68. Transformation to rectangular coördinates . . . . .	154
69. Simplification and discussion of the equation in rectangular coördinates. The parabola, $e = 1$ . . . . .	154
70. Simplification and discussion of the equation in rectangular coördinates. Central conics, $e \geq 1$ . . . . .	158
71. Conjugate hyperbolas and asymptotes . . . . .	165
72. The equilateral hyperbola referred to its asymptotes . . . . .	167

SECTION	PAGE
73. Focal property of central conics . . . . .	168
74. Mechanical construction of conics . . . . .	168
75. Types of loci of equations of the second degree . . . . .	170
76. Construction of the locus of an equation of the second degree . . . . .	173
77. Systems of conics . . . . .	176

## CHAPTER IX

## TANGENTS AND NORMALS

78. The slope of the tangent . . . . .	180
79. Equations of tangents and normals . . . . .	182
80. Equations of tangents and normals to the conic sections . . . . .	184
81. Tangents to a curve from a point not on the curve . . . . .	186
82. Properties of tangents and normals to conics . . . . .	188
83. Tangent in terms of its slope . . . . .	192

## CHAPTER X

## CARTESIAN COÖRDINATES IN SPACE

84. Cartesian coördinates . . . . .	196
85. Orthogonal projections. Lengths . . . . .	198

## CHAPTER XI

## SURFACES, CURVES, AND EQUATIONS

86. Loci in space . . . . .	201
87. Equation of a surface. First fundamental problem . . . . .	201
88. Equations of a curve. First fundamental problem . . . . .	202
89. Locus of one equation. Second fundamental problem . . . . .	205
90. Locus of two equations. Second fundamental problem . . . . .	205
91. Discussion of the equations of a curve. Third fundamental problem . . . . .	206
92. Discussion of the equation of a surface. Third fundamental problem . . . . .	207
93. Plane and straight line . . . . .	210
94. The sphere . . . . .	211
95. Cylinders . . . . .	213
96. Cones . . . . .	214
97. Non-degenerate quadrics . . . . .	215

## ANALYTIC GEOMETRY

## CHAPTER I

## REVIEW OF ALGEBRA AND TRIGONOMETRY

**1. Numbers.** The numbers arising in carrying out the operations of Algebra are of two kinds, *real* and *imaginary*.

A *real number* is a number whose square is a *positive* number. Zero also is a real number.

A *pure imaginary number* is a number whose square is a *negative* number. Every such number reduces to the square root of a negative number, and hence has the form  $b\sqrt{-1}$ , where  $b$  is a real number, and  $(\sqrt{-1})^2 = -1$ .

An *imaginary* or *complex number* is a number which may be written in the form  $a + b\sqrt{-1}$ , where  $a$  and  $b$  are real numbers, and  $b$  is not zero. Evidently the square of an imaginary number is in general also an imaginary number, since

$$(a + b\sqrt{-1})^2 = a^2 - b^2 + 2ab\sqrt{-1},$$

which is imaginary if  $a$  is not equal to zero.

**2. Constants.** A quantity whose value remains unchanged is called a *constant*.

*Numerical* or *absolute constants* retain the same values in all problems, as 2, -3,  $\sqrt{7}$ ,  $\pi$ , etc.

*Arbitrary constants*, or *parameters*, are constants to which any one of an unlimited set of numerical values may be assigned, and these assigned values are retained throughout the investigation.

Arbitrary constants are denoted by letters, usually by letters from the first part of the alphabet. In order to increase the number of symbols at our

disposal, it is convenient to use *primes (accents)* or *subscripts* or both. For example:

Using primes,

$a'$  (read "*a* prime or *a* first"),  $a''$  (read "*a* double prime or *a* second"),  $a'''$  (read "*a* third"), are all different constants.

Using subscripts,

$b_1$  (read "*b* one"),  $b_2$  (read "*b* two"), are different constants.

Using both,

$c_1'$  (read "*c* one prime"),  $c_3''$  (read "*c* three double prime"), are different constants.

**3. The quadratic. Typical form.** Any quadratic equation may by transposing and collecting the terms be written in the Typical Form

$$(1) \quad Ax^2 + Bx + C = 0,$$

in which the *unknown* is denoted by  $x$ . The coefficients  $A$ ,  $B$ ,  $C$  are arbitrary constants, and may have any values whatever, except that  $A$  cannot equal zero, since in that case the equation would be no longer of the second degree.  $C$  is called the **constant term**.

The left-hand member

$$(2) \quad Ax^2 + Bx + C$$

is called a **quadratic**, and any quadratic may be written in this Typical Form, in which the letter  $x$  represents the unknown. The quantity  $B^2 - 4AC$  is called the **discriminant** of either (1) or (2), and is denoted by  $\Delta$ .

That is, the discriminant  $\Delta$  of a quadratic or quadratic equation in the Typical Form is equal to the square of the coefficient of the first power of the unknown diminished by four times the product of the coefficient of the second power of the unknown by the constant term.

The roots of a quadratic are those numbers which make the quadratic equal to zero when substituted for the unknown.

The roots of the quadratic (2) are also said to be roots of the quadratic equation (1). A root of a quadratic equation is said to **satisfy** that equation.

In Algebra it is shown that (2) or (1) has two roots,  $x_1$  and  $x_2$ , obtained by solving (1), namely,

$$(3) \quad \begin{cases} x_1 = -\frac{B}{2A} + \frac{1}{2A} \sqrt{B^2 - 4AC}, \\ x_2 = -\frac{B}{2A} - \frac{1}{2A} \sqrt{B^2 - 4AC}. \end{cases}$$

Adding these values, we have

$$(4) \quad x_1 + x_2 = -\frac{B}{A}.$$

Multiplying gives

$$(5) \quad x_1 x_2 = \frac{C}{A}.$$

Hence

**Theorem I.** *The sum of the roots of a quadratic is equal to the coefficient of the first power of the unknown with its sign changed divided by the coefficient of the second power.*

*The product of the roots equals the constant term divided by the coefficient of the second power.*

The quadratic (2) may be written in the form

$$(6) \quad Ax^2 + Bx + C \equiv A(x - x_1)(x - x_2),$$

as may be readily shown by multiplying out the right-hand member and substituting from (4) and (5).

For example, since the roots of  $3x^2 - 4x + 1 = 0$  are 1 and  $\frac{1}{3}$ , we have identically  $3x^2 - 4x + 1 \equiv 3(x - 1)(x - \frac{1}{3})$ .

The character of the roots  $x_1$  and  $x_2$  as numbers (§ 1) when the coefficients  $A, B, C$  are real numbers evidently depends entirely upon the discriminant. This dependence is stated in

**Theorem II.** *If the coefficients of a quadratic are real numbers, and if the discriminant be denoted by  $\Delta$ , then*

*when  $\Delta$  is positive the roots are real and unequal;*

*when  $\Delta$  is zero the roots are real and equal;*

*when  $\Delta$  is negative the roots are imaginary.*

\*The sign  $\equiv$  is read "is identical with," and means that the two expressions connected by this sign differ only in form.

In the three cases distinguished by Theorem II the quadratic may be written in three forms in which only *real numbers* appear. These are

$$(7) \begin{cases} Ax^2 + Bx + C \equiv A(x-x_1)(x-x_2), \text{ from (6), if } \Delta \text{ is positive;} \\ Ax^2 + Bx + C \equiv A(x-x_1)^2, \text{ from (6), if } \Delta \text{ is zero;} \\ Ax^2 + Bx + C \equiv A \left[ \left( x + \frac{B}{2A} \right)^2 + \frac{4AC - B^2}{4A^2} \right], \text{ if } \Delta \text{ is negative.} \end{cases}$$

The last identity is proved thus:

$$\begin{aligned} Ax^2 + Bx + C &\equiv A \left( x^2 + \frac{B}{A}x + \frac{C}{A} \right) \\ &\equiv A \left( x^2 + \frac{B}{A}x + \frac{B^2}{4A^2} + \frac{C}{A} - \frac{B^2}{4A^2} \right), \end{aligned}$$

adding and subtracting  $\frac{B^2}{4A^2}$  within the parenthesis.

$$\therefore Ax^2 + Bx + C \equiv A \left[ \left( x + \frac{B}{2A} \right)^2 + \frac{4AC - B^2}{4A^2} \right]. \quad \text{Q.E.D.}$$

**4. Special quadratics.** If one or both of the coefficients  $B$  and  $C$  in (1), p. 2, is zero, the quadratic is said to be **special**.

CASE I.  $C = 0$ .

Equation (1) now becomes, by factoring,

$$(1) \quad Ax^2 + Bx \equiv x(Ax + B) = 0.$$

Hence the roots are  $x_1 = 0$ ,  $x_2 = -\frac{B}{A}$ . Therefore one root of a quadratic equation is zero if the constant term of that equation is zero. And *conversely*, if zero is a root of a quadratic, the constant term must disappear. For if  $x = 0$  satisfies (1), p. 2, by substitution we have  $C = 0$ .

CASE II.  $B = 0$ .

Equation (1), p. 2, now becomes

$$(2) \quad Ax^2 + C = 0.$$

From Theorem I, p. 3,  $x_1 + x_2 = 0$ , that is,

$$(3) \quad x_1 = -x_2.$$



Therefore, if the coefficient of the first power of the unknown in a quadratic equation is zero, the roots are equal numerically but have opposite signs. Conversely, if the roots of a quadratic equation are numerically equal but opposite in sign, then the coefficient of the first power of the unknown must disappear. For, since the sum of the roots is zero, we must have, by Theorem I,  $B = 0$ .

CASE III.  $B = C = 0$ .

Equation (1), p. 2, now becomes

$$(4) \quad Ax^2 = 0.$$

Hence the roots are both equal to zero, since this equation requires that  $x^2 = 0$ , the coefficient  $A$  being, by hypothesis, always different from zero.

### 5. Cases when the roots of a quadratic are not independent.

If a relation exists between the roots  $x_1$  and  $x_2$  of the Typical Form

$$Ax^2 + Bx + C = 0,$$

then this relation imposes a *condition* upon the coefficients  $A$ ,  $B$ , and  $C$ , which is expressed by an equation involving these constants.

For example, if the roots are equal, that is, if  $x_1 = x_2$ , then  $B^2 - 4AC = 0$ , by Theorem II, p. 3.

Again, if one root is zero, then  $x_1x_2 = 0$ ; hence  $C = 0$ , by Theorem I, p. 3.

This correspondence may be stated in parallel columns thus:

#### *Quadratic in Typical Form*

*Relation between the  
roots*

*Equation of condition satisfied  
by the coefficients*

In many problems the coefficients involve one or more arbitrary constants, and it is often required to find the equation of condition satisfied by the latter when a given relation exists between the roots. Several examples of this kind will now be worked out.

**Ex. 1.** What must be the value of the parameter  $k$  if zero is a root of the equation

$$(1) \quad 2x^2 - 6x + k^2 - 3k - 4 = 0?$$

*Solution.* Here  $A = 2$ ,  $B = -6$ ,  $C = k^2 - 3k - 4$ . By Case I, p. 4, zero is a root when, and only when,  $C = 0$ .

$$\therefore k^2 - 3k - 4 = 0.$$

Solving,

$$k = 4 \text{ or } -1. \quad \text{Ans.}$$

**Ex. 2.** For what values of  $k$  are the roots of the equation

$$kx^2 + 2kx - 4x = 2 - 3k$$

real and equal?

*Solution.* Writing the equation in the Typical Form, we have

$$(2) \quad kx^2 + (2k - 4)x + (3k - 2) = 0.$$

Hence, in this case,

$$A = k, \quad B = 2k - 4, \quad C = 3k - 2.$$

Calculating the discriminant  $\Delta$ , we get

$$\begin{aligned} \Delta &= (2k - 4)^2 - 4k(3k - 2) \\ &= -8k^2 - 8k + 16 = -8(k^2 + k - 2). \end{aligned}$$

By Theorem II, p. 3, the roots are real and equal when, and only when,  $\Delta = 0$ .

$$\therefore k^2 + k - 2 = 0.$$

Solving,

$$k = -2 \text{ or } 1. \quad \text{Ans.}$$

Verifying by substituting these answers in the given equation (2):

when  $k = -2$ , the equation (2) becomes  $-2x^2 - 8x - 8 = 0$ , or  $-2(x+2)^2 = 0$ ;

when  $k = 1$ , the equation (2) becomes  $x^2 - 2x + 1 = 0$ , or  $(x-1)^2 = 0$ .

Hence, for these values of  $k$ , the left-hand member of (2) may be transformed as in (7), p. 4.

**Ex. 3.** What equation of condition must be satisfied by the constants  $a$ ,  $b$ ,  $k$ , and  $m$  if the roots of the equation

$$(3) \quad (b^2 + a^2m^2)y^2 + 2a^2kmy + a^2k^2 - a^2b^2 = 0$$

are equal?

*Solution.* The equation (3) is already in the Typical Form; hence

$$A = b^2 + a^2m^2, \quad B = 2a^2km, \quad C = a^2k^2 - a^2b^2.$$

By Theorem II, p. 3, the discriminant  $\Delta$  must vanish; hence

$$\Delta = 4a^4k^2m^2 - 4(b^2 + a^2m^2)(a^2k^2 - a^2b^2) = 0.$$

Multiplying out and reducing,

$$a^2b^2(k^2 - a^2m^2 - b^2) = 0. \quad \text{Ans.}$$

**Ex. 4.** For what values of  $k$  do the common solutions of the simultaneous equations

$$(4) \quad 3x + 4y = k,$$

$$(5) \quad x^2 + y^2 = 25$$

become identical?

*Solution.* Solving (4) for  $y$ , we have

$$(6) \quad y = \frac{1}{4}(k - 3x).$$

Substituting in (5) and arranging in the Typical Form gives

$$(7) \quad 25x^2 - 6kx + k^2 - 400 = 0.$$

Let the roots of (7) be  $x_1$  and  $x_2$ . Then substituting in (6) will give the corresponding values  $y_1$  and  $y_2$  of  $y$ , namely,

$$(8) \quad y_1 = \frac{1}{4}(k - 3x_1), \quad y_2 = \frac{1}{4}(k - 3x_2),$$

and we shall have two common solutions  $(x_1, y_1)$  and  $(x_2, y_2)$  of (4) and (5). But, by the condition of the problem, *these solutions must be identical*. Hence we must have

$$(9) \quad x_1 = x_2 \text{ and } y_1 = y_2.$$

If, however, the first of these is true ( $x_1 = x_2$ ), then from (8)  $y_1$  and  $y_2$  will also be equal.

Therefore the two common solutions of (4) and (5) become identical when, and only when, the roots of the equation (7) are equal; that is, when the discriminant  $\Delta$  of (7) vanishes (Theorem II, p. 3).

$$\therefore \Delta = 36k^2 - 100(k^2 - 400) = 0.$$

Solving,

$$k^2 = 625,$$

$$k = 25 \text{ or } -25. \quad \text{Ans.}$$

*Verification.* Substituting each value of  $k$  in (7),

when  $k=25$ , the equation (7) becomes  $x^2 - 6x + 9 = 0$ , or  $(x-3)^2 = 0$ ;  $\therefore x=3$ ;

when  $k=-25$ , the equation (7) becomes  $x^2 + 6x + 9 = 0$ , or  $(x+3)^2 = 0$ ;  $\therefore x=-3$ .

Then from (6), substituting corresponding values of  $k$  and  $x$ ,

$$\text{when } k = 25 \text{ and } x = 3, \text{ we have } y = \frac{1}{4}(25 - 9) = 4;$$

$$\text{when } k = -25 \text{ and } x = -3, \text{ we have } y = \frac{1}{4}(-25 + 9) = -4.$$

Therefore the two common solutions of (4) and (5) are identical for each of these values of  $k$ , namely,

$$\text{if } k = 25, \text{ the common solutions reduce to } x = 3, y = 4;$$

$$\text{if } k = -25, \text{ the common solutions reduce to } x = -3, y = -4.$$

## PROBLEMS

1. Calculate the discriminant of each of the following quadratics, determine the sum, the product, and the character of the roots, and write each quadratic in one of the forms (7), p. 4.

(a)  $2x^2 - 6x + 4.$

(d)  $4x^2 - 4x + 1.$

(b)  $x^2 - 9x - 10.$

(e)  $5x^2 + 10x + 5.$

(c)  $1 - x - x^2.$

(f)  $3x^2 - 5x - 22.$

2. For what real values of the parameter  $k$  will one root of each of the following equations be zero?

(a)  $6x^2 + 5kx - 3k^2 + 3 = 0.$

*Ans.*  $k = \pm 1.$

(b)  $2k - 3x^2 + 6x - k^2 + 3 = 0.$

*Ans.*  $k = -1$  or  $3.$

3. For what real values of the parameter are the roots of the following equations equal? Verify your answers.

(a)  $kx^2 - 3x - 1 = 0.$

*Ans.*  $k = -\frac{9}{4}.$

(b)  $x^2 - kx + 9 = 0.$

*Ans.*  $k = \pm 6.$

(c)  $2kx^2 + 3kx + 12 = 0.$

*Ans.*  $k = \frac{3}{2}.$

(d)  $2x^2 + kx - 1 = 0.$

*Ans.* None.

(e)  $5x^2 - 3x + 5k^2 = 0.$

*Ans.*  $k = \pm \frac{1}{5}.$

(f)  $x^2 + kx + k^2 + 2 = 0.$

*Ans.* None.

(g)  $x^2 - 2kx - k - \frac{1}{4} = 0.$

*Ans.*  $k = -\frac{1}{2}.$

4. Derive the equation of condition in order that the roots of the following equations may be equal.

(a)  $m^2x^2 + 2kmx - 2px = -k^2.$

*Ans.*  $p(p - 2km) = 0.$

(b)  $x^2 + 2mpx + 2bp = 0.$

*Ans.*  $p(m^2p - 2b) = 0.$

(c)  $2mx^2 + 2bx + a^2 = 0.$

*Ans.*  $b^2 = 2a^2m.$

5. For what real values of the parameter do the common solutions of the following pairs of simultaneous equations become identical?

(a)  $x + 2y = k, x^2 + y^2 = 5.$

*Ans.*  $k = \pm 5.$

(b)  $y = mx - 1, x^2 = 4y.$

*Ans.*  $m = \pm 1.$

(c)  $2x - 3y = b, x^2 + 2x = 3y.$

*Ans.*  $b = 0.$

(d)  $y = mx + 10, x^2 + y^2 = 10.$

*Ans.*  $m = \pm 3.$

(e)  $lx + y - 2 = 0, x^2 - 8y = 0.$

*Ans.* None.

(f)  $x + 4y = c, x^2 + 2y^2 = 9.$

*Ans.*  $c = \pm 9.$

(g)  $x^2 + y^2 - x - 2y = 0, x + 2y = c.$

*Ans.*  $c = 0$  or  $5.$

(h)  $x^2 + 4y^2 - 8x = 0, mx - y - 2m = 0.$

*Ans.* None.

6. If the common solutions of the following pairs of simultaneous equations are to become identical, what is the corresponding equation of condition?

(a)  $bx + ay = ab, y^2 = 2px.$

*Ans.*  $ap(2b^2 + ap) = 0.$

(b)  $y = mx + b, Ax^2 + By = 0.$

*Ans.*  $B(m^2B - 4bA) = 0.$

(c)  $y = m(x - a), By^2 + Dx = 0.$

*Ans.*  $D(4am^2B - D) = 0.$

**6. Variables.** A *variable* is a quantity to which, in the same investigation, an unlimited number of values can be assigned. In a particular problem the variable may, in general, assume any value within certain limits imposed by the nature of the problem. It is convenient to indicate these limits by *inequalities*.

For example, if the variable  $x$  can assume any value between  $-2$  and  $5$ , that is, if  $x$  must be greater\* than  $-2$  and less than  $5$ , the simultaneous inequalities

$$x > -2, \quad x < 5,$$

are written in the more compact form

$$-2 < x < 5.$$

Similarly, if the conditions of the problem limit the values of the variable  $x$  to any negative number less than or equal to  $-2$ , and to any positive number greater than or equal to  $5$ , the conditions

$$x < -2 \text{ or } x = -2, \text{ and } x > 5 \text{ or } x = 5$$

are abbreviated to

$$x \leq -2 \text{ and } x \geq 5.$$

Write inequalities to express that the variable

(a)  $x$  has any value from  $0$  to  $5$  inclusive.

(b)  $y$  has any value less than  $-2$  or greater than  $-1$ .

(c)  $x$  has any value not less than  $-8$  nor greater than  $2$ .

**7. Equations in several variables.** In Analytic Geometry we are concerned chiefly with equations in two or more variables.

An equation is said to be satisfied by any given set of values of the variables if the equation reduces to a numerical equality when these values are substituted for the variables.

For example,  $x = 2$ ,  $y = -3$  satisfy the equation

$$2x^2 + 3y^2 = 35,$$

since

$$2(2)^2 + 3(-3)^2 = 35.$$

Similarly,  $x = -1$ ,  $y = 0$ ,  $z = -4$  satisfy the equation

$$2x^2 - 3y^2 + z^2 - 18 = 0,$$

since

$$2(-1)^2 - 3 \times 0 + (-4)^2 - 18 = 0.$$

\* The meaning of *greater* and *less* for real numbers (§ 1) is defined as follows:  $a$  is greater than  $b$  when  $a - b$  is a positive number, and  $a$  is less than  $b$  when  $a - b$  is negative. Hence any negative number is less than any positive number; and if  $a$  and  $b$  are both negative, then  $a$  is greater than  $b$  when the numerical value of  $a$  is less than the numerical value of  $b$ .

Thus  $3 < 5$ , but  $-3 > -5$ . Therefore changing signs throughout an inequality reverses the inequality sign.

An equation is said to be **algebraic** in any number of variables, for example  $x, y, z$ , if it can be transformed into an equation each of whose members is a sum of terms of the form  $ax^m y^n z^p$ , where  $a$  is a constant and  $m, n, p$  are positive integers or zero.

Thus the equations  $x^4 + x^2 y^2 - z^3 + 2x - 5 = 0$ ,

$$x^5 y + 2x^2 y^2 = -y^3 + 5x^2 + 2 - x$$

are algebraic.

The equation  $x^{\frac{1}{2}} + y^{\frac{1}{2}} = a^{\frac{1}{2}}$

is algebraic.

For, squaring, we get  $x + 2x^{\frac{1}{2}}y^{\frac{1}{2}} + y = a$ .

Transposing,  $2x^{\frac{1}{2}}y^{\frac{1}{2}} = a - x - y$ .

Squaring,  $4xy = a^2 + x^2 + y^2 - 2ax - 2ay + 2xy$ .

Transposing,  $x^2 + y^2 - 2xy - 2ax - 2ay + a^2 = 0$ .

Q.E.D.

The **degree** of an algebraic equation is equal to the highest degree of any of its terms.\* An algebraic equation is said to be **arranged with respect to the variables** when all its terms are transposed to the left-hand side and written in the order of descending degrees.

For example, to *arrange* the equation

$$2x'^2 + 3y' + 6x' - 2x'y' - 2 + x'^3 = x'^2 y' - y'^2$$

with respect to the variables  $x', y'$ , we transpose and rewrite the terms in the order

$$x'^3 - x'^2 y' + 2x'^2 - 2x'y' + y'^2 + 6x' + 3y' - 2 = 0.$$

This equation is of the third degree.

An equation which is not algebraic is said to be **transcendental**.

Examples of transcendental equations are

$$y = \sin x, \quad y = 2^x, \quad \log y = 3x.$$

### PROBLEMS

1. Show that each of the following equations is algebraic; arrange the terms according to the variables  $x, y$ , or  $x, y, z$ , and determine the degree.

(a)  $x^2 + \sqrt{y-5} + 2x = 0$ .

(b)  $x^{\frac{3}{2}} + y + 3x = 0$ .

(c)  $xy + 3x^4 + 6x^2 y - 7xy^3 + 5x - 6 + 8y = 2xy^2$ .

(d)  $x + y + z + x^2 z - 3xy - 2z^2 = 5$ .

(e)  $y = 2 + \sqrt{x^2 - 2x - 5}$ .

\* The degree of any term is the sum of the exponents of the variables in that term.

(f)  $y = x + 5 + \sqrt{2x^2 - 6x + 3}$ .

(g)  $x = -\frac{1}{2}D + \sqrt{\frac{D^2}{4} - F - Ey - y^2}$ .

(h)  $y = Ax + B + \sqrt{Lx^2 + Mx + N}$ .

2. Show that the homogeneous quadratic \*

$$Ax^2 + Bxy + Cy^2$$

may be written in one of the three forms below analogous to (7), p. 4, if the discriminant  $\Delta \equiv B^2 - 4AC$  satisfies the condition given :

CASE I.  $Ax^2 + Bxy + Cy^2 \equiv A(x - l_1y)(x - l_2y)$ , if  $\Delta > 0$ ;

CASE II.  $Ax^2 + Bxy + Cy^2 \equiv A(x - l_1y)^2$ , if  $\Delta = 0$ ;

CASE III.  $Ax^2 + Bxy + Cy^2 \equiv A\left[\left(x + \frac{B}{2A}y\right)^2 + \frac{4AC - B^2}{4A^2}y^2\right]$ , if  $\Delta < 0$ .

8. Functions of an angle in a right triangle. In any right triangle one of whose acute angles is  $A$ , the functions of  $A$  are defined as follows :

$\sin A = \frac{\text{opposite side}}{\text{hypotenuse}}$ ,  $\frac{a}{c}$

$\csc A = \frac{\text{hypotenuse}}{\text{opposite side}}$ ,  $\frac{c}{a}$

$\cos A = \frac{\text{adjacent side}}{\text{hypotenuse}}$ ,  $\frac{b}{c}$

$\sec A = \frac{\text{hypotenuse}}{\text{adjacent side}}$ ,  $\frac{c}{b}$

$\tan A = \frac{\text{opposite side}}{\text{adjacent side}}$ ,  $\frac{a}{b}$

$\cot A = \frac{\text{adjacent side}}{\text{opposite side}}$ ,  $\frac{b}{a}$

From the above the theorem is easily derived :

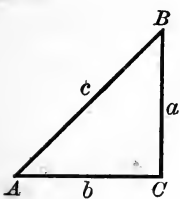

In a right triangle a side is equal to the product of the hypotenuse and the sine of the angle opposite to that side, or of the hypotenuse and the cosine of the angle adjacent to that side.

9. Angles in general. In Trigonometry an angle  $XOA$  is considered as generated by the line  $OA$  rotating from an initial position  $OX$ . The angle is positive when  $OA$  rotates from  $OX$  counter-clockwise, and negative when the direction of rotation of  $OA$  is clockwise.

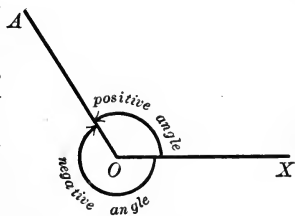

\* The coefficients  $A, B, C$  and the numbers  $l_1, l_2$  are supposed real.

The fixed line  $OX$  is called the *initial line*, the line  $OA$  the *terminal line*.

*Measurement of angles.* There are two important methods of measuring angular magnitude, that is, there are two unit angles.

*Degree measure.* The unit angle is  $\frac{1}{360}$  of a complete revolution, and is called a *degree*.

*Circular measure.* The unit angle is an angle whose subtending arc is equal to the radius of that arc, and is called a *radian*.

The fundamental relation between the unit angles is given by the equation

$$180 \text{ degrees} = \pi \text{ radians } (\pi = 3.14159 \dots).$$

Or also, by solving this,

$$1 \text{ degree} = \frac{\pi}{180} = .0174 \dots \text{ radians,}$$

$$1 \text{ radian} = \frac{180}{\pi} = 57.29 \dots \text{ degrees.}$$

These equations enable us to change from one measurement to another. In the higher mathematics circular measure is always used, and will be adopted in this book.

The generating line is conceived of as rotating around  $O$  through as many revolutions as we choose. Hence the important result:

*Any real number is the circular measure of some angle, and conversely, any angle is measured by a real number.*

## 10. Formulas and theorems from Trigonometry.

$$1. \cot x = \frac{1}{\tan x}; \sec x = \frac{1}{\cos x}; \csc x = \frac{1}{\sin x}.$$

$$2. \tan x = \frac{\sin x}{\cos x}; \cot x = \frac{\cos x}{\sin x}.$$

$$3. \sin^2 x + \cos^2 x = 1; 1 + \tan^2 x = \sec^2 x; 1 + \cot^2 x = \csc^2 x.$$

$$4. \sin(-x) = -\sin x; \csc(-x) = -\csc x; \\ \cos(-x) = \cos x; \sec(-x) = \sec x; \\ \tan(-x) = -\tan x; \cot(-x) = -\cot x.$$



$$\begin{aligned}
 5. \quad \sin(\pi - x) &= \sin x; \quad \sin(\pi + x) = -\sin x; \\
 \cos(\pi - x) &= -\cos x; \quad \cos(\pi + x) = -\cos x; \\
 \tan(\pi - x) &= -\tan x; \quad \tan(\pi + x) = \tan x;
 \end{aligned}$$

$$\begin{aligned}
 6. \quad \sin\left(\frac{\pi}{2} - x\right) &= \cos x; \quad \sin\left(\frac{\pi}{2} + x\right) = \cos x; \\
 \cos\left(\frac{\pi}{2} - x\right) &= \sin x; \quad \cos\left(\frac{\pi}{2} + x\right) = -\sin x; \\
 \tan\left(\frac{\pi}{2} - x\right) &= \cot x; \quad \tan\left(\frac{\pi}{2} + x\right) = -\cot x.
 \end{aligned}$$

$$7. \quad \sin(2\pi - x) = \sin(-x) = -\sin x, \text{ etc. } ?$$

$$* 8. \quad \sin(x + y) = \sin x \cos y + \cos x \sin y.$$

$$9. \quad \sin(x - y) = \sin x \cos y - \cos x \sin y.$$

$$* 10. \quad \cos(x + y) = \cos x \cos y - \sin x \sin y.$$

$$11. \quad \cos(x - y) = \cos x \cos y + \sin x \sin y.$$

$$12. \quad \tan(x + y) = \frac{\tan x + \tan y}{1 - \tan x \tan y} \quad 13. \quad \tan(x - y) = \frac{\tan x - \tan y}{1 + \tan x \tan y}.$$

$$14. \quad \sin 2x = 2 \sin x \cos x; \quad \cos 2x = \cos^2 x - \sin^2 x; \quad \tan 2x = \frac{2 \tan x}{1 - \tan^2 x}.$$

$$15. \quad \sin \frac{x}{2} = \pm \sqrt{\frac{1 - \cos x}{2}}; \quad \cos \frac{x}{2} = \pm \sqrt{\frac{1 + \cos x}{2}}; \quad \tan \frac{x}{2} = \pm \sqrt{\frac{1 - \cos x}{1 + \cos x}}.$$

16. *Theorem. Law of sines.* In any triangle the sides are proportional to the sines of the opposite angles;

that is,

$$\frac{a}{\sin A} = \frac{b}{\sin B} = \frac{c}{\sin C}.$$

17. *Theorem. Law of cosines.* In any triangle the square of a side equals the sum of the squares of the two other sides diminished by twice the product of those sides by the cosine of their included angle;

that is,

$$a^2 = b^2 + c^2 - 2bc \cos A.$$

18. *Theorem. Area of a triangle.* The area of any triangle equals one half the product of two sides by the sine of their included angle;

that is,

$$\text{area} = \frac{1}{2} ab \sin C = \frac{1}{2} bc \sin A = \frac{1}{2} ca \sin B.$$

## 11. Natural values of trigonometric functions.

Angle in Radians	Angle in Degrees	Sin	Cos	Tan	Cot		
.0000	0°	.0000	1.0000	.0000	$\infty$	90°	1.5708
.0873	5°	.0872	.9962	.0875	11.430	85°	1.4835
.1745	10°	.1736	.9848	.1763	5.671	80°	1.3963
.2618	15°	.2588	.9659	.2679	3.732	75°	1.3090
.3491	20°	.3420	.9397	.3640	2.747	70°	1.2217
.4363	25°	.4226	.9063	.4663	2.145	65°	1.1345
.5236	30°	.5000	.8660	.5774	1.732	60°	1.0472
.6109	35°	.5736	.8192	.7002	1.428	55°	.9599
.6981	40°	.6428	.7660	.8391	1.192	50°	.8727
.7854	45°	.7071	.7071	1.0000	1.000	45°	.7854
		Cos	Sin	Cot	Tan	Angle in Degrees	Angle in Radians

Angle in Radians	Angle in Degrees	Sin	Cos	Tan	Cot	Sec	Csc
0	0°	0	1	0	$\infty$	1	$\infty$
$\frac{\pi}{2}$	90°	1	0	$\infty$	0	$\infty$	1
$\pi$	180°	0	-1	0	$\infty$	-1	$\infty$
$\frac{3\pi}{2}$	270°	-1	0	$\infty$	0	$\infty$	-1
$2\pi$	360°	0	1	0	$\infty$	1	$\infty$

Angle in Radians	Angle in Degrees	Sin	Cos	Tan	Cot	Sec	Csc
0	0°	0	1	0	∞	1	∞
$\frac{\pi}{6}$	30°	$\frac{1}{2}$	$\frac{\sqrt{3}}{2}$	$\frac{\sqrt{3}}{3}$	$\sqrt{3}$	$\frac{2\sqrt{3}}{3}$	2
$\frac{\pi}{4}$	45°	$\frac{\sqrt{2}}{2}$	$\frac{\sqrt{2}}{2}$	1	1	$\sqrt{2}$	$\sqrt{2}$
$\frac{\pi}{3}$	60°	$\frac{\sqrt{3}}{2}$	$\frac{1}{2}$	$\sqrt{3}$	$\frac{\sqrt{3}}{3}$	2	$\frac{2\sqrt{3}}{3}$
$\frac{\pi}{2}$	90°	1	0	∞	0	∞	1

### 12. Rules for signs.

Quadrant	Sin	Cos	Tan	Cot	Sec	Csc
First . . . .	+	+	+	+	+	+
Second . . . .	+	-	-	-	-	+
Third . . . .	-	-	+	+	-	-
Fourth . . . .	-	+	-	-	+	-

### 13. Greek alphabet.

Letters	Names	Letters	Names	Letters	Names
A α	Alpha	I ι	Iota	P ρ	Rho
B β	Beta	K κ	Kappa	Σ σ ς	Sigma
Γ γ	Gamma	Λ λ	Lambda	T τ	Tau
Δ δ	Delta	M μ	Mu	Υ υ	Upsilon
E ε	Epsilon	N ν	Nu	Φ φ	Phi
Z ζ	Zeta	Ξ ξ	Xi	X χ	Chi
H η	Eta	O ο	Omicron	Ψ ψ	Psi
Θ θ	Theta	Π π	Pi	Ω ω	Omega

## CHAPTER II

### CARTESIAN COÖRDINATES

**14. Directed line.** Let  $X'X$  be an indefinite straight line, and let a point  $O$ , which we shall call the **origin** be chosen upon it. Let a unit of length be adopted and assume that lengths measured from  $O$  to the right are *positive*, and to the left *negative*.

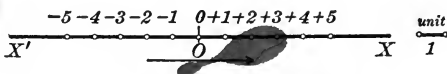

Then any *real* number (p. 1), if taken as the measure of the length of a line  $OP$ , will determine a point  $P$  on the line. Conversely, to each point  $P$  on the line will correspond a real number, namely, the measure of the length  $OP$ , with a positive or negative sign according as  $P$  is to the right or left of the origin.

The direction established upon  $X'X$  by passing from the origin to the points corresponding to the positive numbers is called the **positive direction** on the line. A **directed line** is a straight line upon

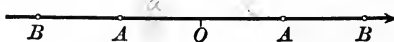

which an origin, a unit of length, and a positive direction have been assumed.

An arrowhead is usually placed upon a directed line to indicate the positive direction.

If  $A$  and  $B$  are any two points of a directed line such that

$$OA = a, \quad OB = b,$$

then the length of the segment  $AB$  is always given by  $b - a$ ; that is, the length of  $AB$  is the difference of the numbers corresponding to  $B$  and  $A$ . This statement is evidently equivalent to the following definition :

For all positions of two points  $A$  and  $B$  on a directed line, the length  $AB$  is given by

$$(1) \quad AB = OB - OA,$$

where  $O$  is the origin.

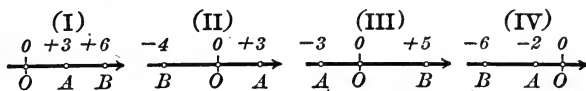

Illustrations.

In Fig. I.  $AB = OB - OA = 6 - 3 = +3$ ;  $BA = OA - OB = 3 - 6 = -3$ ;

II.  $AB = OB - OA = -4 - 3 = -7$ ;  $BA = OA - OB = 3 - (-4) = +7$ ;

III.  $AB = OB - OA = +5 - (-3) = +8$ ;  $BA = OA - OB = -3 - 5 = -8$ ;

IV.  $AB = OB - OA = -6 - (-2) = -4$ ;  $BA = OA - OB = -2 - (-6) = +4$ .

The following properties of lengths on a directed line are obvious :

$$(2) \quad AB = -BA.$$

(3)  $AB$  is positive if the direction from  $A$  to  $B$  agrees with the positive direction on the line, and negative if in the contrary direction.

The phrase "distance between two points" should not be used if these points lie upon a directed line. Instead, we speak of the length  $AB$ , remembering that the lengths  $AB$  and  $BA$  are *not equal*, but that  $AB = -BA$ .

**15. Cartesian\* coördinates.** Let  $X'X$  and  $Y'Y$  be two directed lines intersecting at  $O$ , and

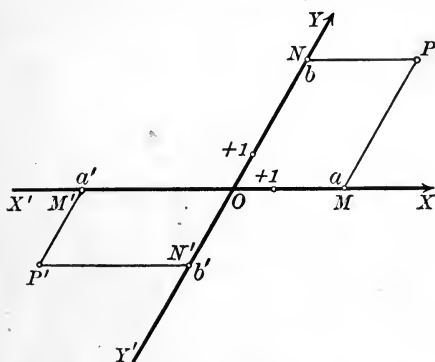

let  $P$  be any point in their plane. Draw lines through  $P$  parallel to  $X'X$  and  $Y'Y$  respectively. Then, if

$$OM = a, \quad ON = b,$$

the numbers  $a, b$  are called the **Cartesian coördinates** of  $P$ ,  $a$  the **abscissa** and  $b$  the **ordinate**. The directed lines  $X'X$  and  $Y'Y$  are called the

\* So called after René Descartes, 1596-1650, who first introduced the idea of coördinates into the study of Geometry.

axes of coördinates,  $X'X$  the axis of abscissas,  $Y'Y$  the axis of ordinates, and their intersection  $O$  the origin.

The coördinates  $a, b$  of  $P$  are written  $(a, b)$ , and the symbol  $P(a, b)$  is to be read: "The point  $P$ , whose coördinates are  $a$  and  $b$ ."

Any point  $P$  in the plane determines two numbers, the coördinates of  $P$ . Conversely, given two real numbers  $a'$  and  $b'$ , then a point  $P'$  in the plane may always be constructed whose coördinates are  $(a', b')$ . For lay off  $OM' = a'$ ,  $ON' = b'$ , and draw lines parallel to the axes through  $M'$  and  $N'$ . These lines intersect at  $P'(a', b')$ . Hence

*Every point determines a pair of real numbers, and conversely, a pair of real numbers determines a point.*

The imaginary numbers of Algebra have no place in this representation, and for this reason elementary Analytic Geometry is concerned only with the real numbers of Algebra.

**16. Rectangular coördinates.** A rectangular system of coördinates is determined when the axes  $X'X$  and  $Y'Y$  are perpendicular

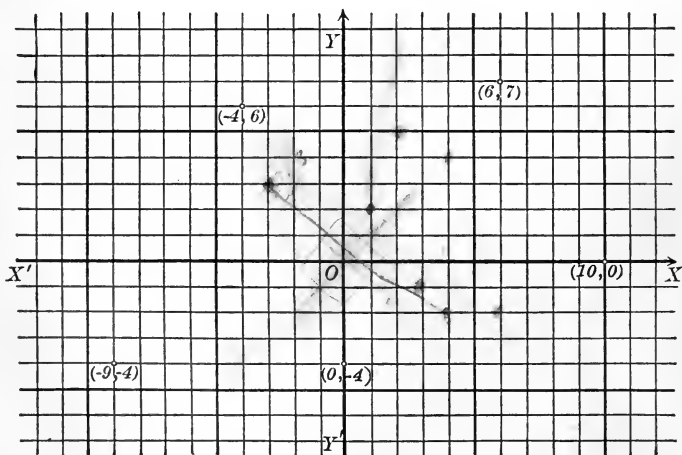

to each other. This is the usual case, and will be assumed unless otherwise stated.

The work of plotting points in a rectangular system is much simplified by the use of *coördinate* or *plotting paper*, constructed by ruling off the plane into equal squares, the sides being parallel to the axes.

In the figure, p. 18, several points are plotted, the unit of length being assumed equal to one division on each axis. The method is simply this:

Count off from  $O$  along  $X'X$  a number of divisions equal to the given abscissa, and then from the point so determined a number of divisions equal to the given ordinate, observing the

**Rule for signs:**

*Abscissas are positive or negative according as they are laid off to the right or left of the origin. Ordinates are positive or negative according as they are laid off above or below the axis of  $x$ .*

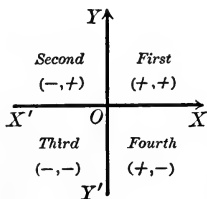

Rectangular axes divide the plane into four portions called *quadrants*; these are numbered as in the figure, in which the proper signs of the coördinates are also indicated.

**PROBLEMS**

1. Plot accurately the points  $(3, 2)$ ,  $(3, -2)$ ,  $(-4, 3)$ ,  $(6, 0)$ ,  $(-5, 0)$ ,  $(0, 4)$ .
2. Plot accurately the points  $(1, 6)$ ,  $(3, -2)$ ,  $(-2, 0)$ ,  $(4, -3)$ ,  $(-7, -4)$ ,  $(-2, 4)$ ,  $(0, -1)$ ,  $(\sqrt{3}, \sqrt{2})$ ,  $(-\sqrt{5}, 0)$ .
3. What are the coördinates of the origin? *Ans.*  $(0, 0)$ .
4. In what quadrants do the following points lie if  $a$  and  $b$  are positive numbers:  $(-a, b)$ ?  $(-a, -b)$ ?  $(b, -a)$ ?  $(a, b)$ ?
5. To what quadrants is a point limited if its abscissa is positive? negative? its ordinate is positive? negative?
6. Plot the triangle whose vertices are  $(2, -1)$ ,  $(-2, 5)$ ,  $(-8, -4)$ .
7. Plot the triangle whose vertices are  $(-2, 0)$ ,  $(5\sqrt{3} - 2, 5)$ ,  $(-2, 10)$ .
8. Plot the quadrilateral whose vertices are  $(0, -2)$ ,  $(4, 2)$ ,  $(0, 6)$ ,  $(-4, 2)$ .

9. If a point moves parallel to the axis of  $x$ , which of its coördinates remains constant? if parallel to the axis of  $y$ ?

10. Can a point move when its abscissa is zero? Where? Can it move when its ordinate is zero? Where? Can it move if both abscissa and ordinate are zero? Where will it be?

11. Where may a point be found if its abscissa is 2? if its ordinate is  $-3$ ?

12. Where do all those points lie whose abscissas and ordinates are equal?

13. Two sides of a rectangle of lengths  $a$  and  $b$  coincide with the axes of  $x$  and  $y$  respectively. What are the coördinates of the vertices of the rectangle if it lies in the first quadrant? in the second quadrant? in the third quadrant? in the fourth quadrant?

14. Construct the quadrilateral whose vertices are  $(-3, 6)$ ,  $(-3, 0)$ ,  $(3, 0)$ ,  $(3, 6)$ . What kind of a quadrilateral is it?

15. Join  $(3, 5)$  and  $(-3, -5)$ ; also  $(3, -5)$  and  $(-3, 5)$ . What are the coördinates of the point of intersection of the two lines?

16. Show that  $(x, y)$  and  $(x, -y)$  are symmetrical with respect to  $X'X$ ;  $(x, y)$  and  $(-x, y)$  with respect to  $Y'Y$ ; and  $(x, y)$  and  $(-x, -y)$  with respect to the origin.

17. A line joining two points is bisected at the origin. If the coördinates of one end are  $(a, -b)$ , what will be the coördinates of the other end?

18. Consider the bisectors of the angles between the coördinate axes. What is the relation between the abscissa and ordinate of any point of the bisector in the first and third quadrants? second and fourth quadrants?

19. A square whose side is  $2a$  has its center at the origin. What will be the coördinates of its vertices if the sides are parallel to the axes? if the diagonals coincide with the axes?

$$\text{Ans. } (a, a), (a, -a), (-a, -a), (-a, a); \\ (a\sqrt{2}, 0), (-a\sqrt{2}, 0), (0, a\sqrt{2}), (0, -a\sqrt{2}).$$

20. An equilateral triangle whose side is  $a$  has its base on the axis of  $x$  and the opposite vertex above  $X'X$ . What are the vertices of the triangle if the center of the base is at the origin? if the lower left-hand vertex is at the origin?

$$\text{Ans. } \left(\frac{a}{2}, 0\right), \left(-\frac{a}{2}, 0\right), \left(0, \frac{a\sqrt{3}}{2}\right); \\ (0, 0), (a, 0), \left(\frac{a}{2}, \frac{a\sqrt{3}}{2}\right).$$



**17. Angles.** The angle between two intersecting directed lines is defined to be the angle made by their positive directions. In the figures the angle between the directed lines is the angle marked  $\theta$ .

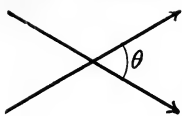

If the directed lines are parallel, then the angle between them is zero or  $\pi$  according as the positive directions agree or do not agree.

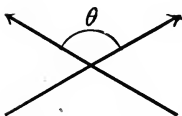

Evidently the angle between two directed lines may have any value from 0 to  $\pi$  inclusive.

Reversing the direction of either directed line changes  $\theta$  to the supplement  $\pi - \theta$ . If both directions are reversed, the angle is unchanged.

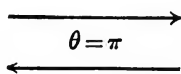
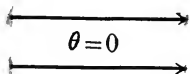

When it is desired to assign a positive direction to a line intersecting  $X'X$ , we shall always assume the *upward direction* as *positive* (see figures).

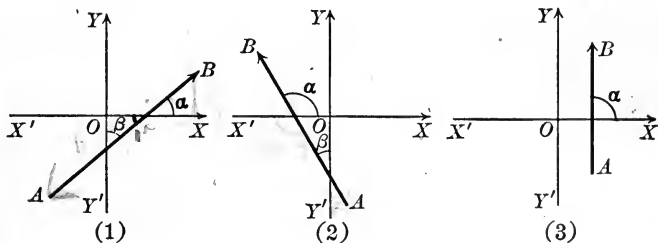

**Theorem I.** *If  $\alpha$  and  $\beta$  are the angles between a line directed upward and the rectangular axes  $OX$  and  $OY$ , then*

(I)  $\cos \beta = \sin \alpha.$

*Proof.* The figures are typical of all possible cases.

In Fig. 1,  $\beta = \frac{\pi}{2} - \alpha,$

and hence  $\cos \beta = \cos \left( \frac{\pi}{2} - \alpha \right) = \sin \alpha.$  (by 6, p. 13)

In Fig. 2,

$$\beta = \alpha - \frac{\pi}{2},$$

and hence

$$\cos \beta = \cos \left( \alpha - \frac{\pi}{2} \right) = \sin \alpha.$$

(by 4 and 6, p. 12)

In Fig. 3,

$$\alpha = \frac{\pi}{2}, \beta = 0.$$

$$\therefore \cos \beta = 1 = \sin \alpha.$$

Q. E. D.

The positive direction of a line parallel to  $X'X$  will be assumed to agree with the positive direction of  $X'X$ , that is, to the right. Hence for such a line  $\alpha = 0$ ,  $\beta = \frac{\pi}{2}$ , and the relation (I) still holds, since

$$\cos \beta = \cos \frac{\pi}{2} = 0 = \sin 0 = \sin \alpha.$$

### PROBLEMS

1. Show that for lines directed downward  $\cos \beta = -\sin \alpha$ .
2. What are the values of  $\alpha$  and  $\beta$  for a line directed N.E.? N.W.? S.E.? S.W.? (The axes are assumed to indicate the four cardinal points of the compass.)
3. Find the relation between the  $\alpha$ 's and  $\beta$ 's of two perpendicular lines directed upward.

$$\text{Ans. } \alpha' - \alpha = \frac{\pi}{2}; \quad \beta' + \beta = \frac{\pi}{2}.$$

**18. Orthogonal projection.** The orthogonal projection of a point upon a line is the foot of the perpendicular let fall from the point upon the line.

Thus in the figure

$M$  is the orthogonal projection of  $P$  on  $X'X$ ;  
 $N$  is the orthogonal projection of  $P$  on  $Y'Y$ ;  
 $P'$  is the orthogonal projection of  $P'$  on  $X'X$ .

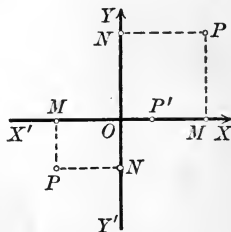

If  $A$  and  $B$  are two points of a directed line, and  $M$  and  $N$  their projections upon a second directed line  $CD$ , then  $MN$  is called the **projection of  $AB$  upon  $CD$** .

**Theorem II. First theorem of projection.** *If A and B are points upon a directed line making an angle  $\gamma$  with a second directed line CD, then the*

(II) **projection of the length AB upon CD = AB cos  $\gamma$ .**

*Proof.* In the figures let

- $a$  = the numerical length of AB,
- $l$  = the numerical length of AS or BT;

then  $a$  and  $l$  are positive numbers giving the lengths of the respective lines, as in Plane Geometry. Now apply the definition of the cosine to the right triangles ABS and ABT (p. 11).

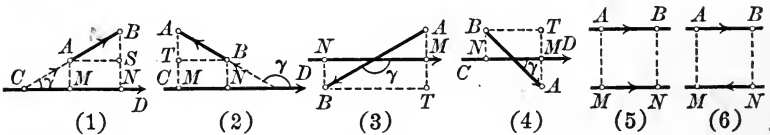

In Fig. 1,  $l = a \cos BAS = a \cos \gamma$ ,  
 $MN = l, AB = a$ .  
 $\therefore MN = AB \cos \gamma$ .

In Fig. 2,  $l = a \cos ABT = a \cos (\pi - \gamma)$   
 $= -a \cos \gamma$ , (by 5, p. 13)  
 $MN = l, AB = -a$ .  
 $\therefore MN = AB \cos \gamma$ .

In Fig. 3,  $l = a \cos ABT = a \cos (\pi - \gamma)$   
 $= -a \cos \gamma$ ,  
 $MN = -l, AB = a$ .  
 $\therefore MN = AB \cos \gamma$ .

In Fig. 4,  $l = a \cos ABT = a \cos \gamma$ ,  
 $MN = -l, AB = -a$ .  
 $\therefore MN = AB \cos \gamma$ .

In Fig. 5,  $\gamma = 0, MN = l, AB = a$ .  
Hence  $MN = AB = AB \cos 0$  (since  $\cos 0 = 1$ ).  
 $\therefore MN = AB \cos \gamma$ .

In Fig. 6,  $\gamma = \pi, MN = -l, AB = a$ .  
Hence  $MN = -AB = AB \cos \pi$  (since  $\cos \pi = -1$ ).  
 $\therefore MN = AB \cos \gamma$ .

19. Lengths. Consider any two given points

$$P_1(x_1, y_1), P_2(x_2, y_2).$$

Then in the figure

$M_1M_2$  = projection of  $P_1P_2$  on  $X'X$ ,

$N_1N_2$  = projection of  $P_1P_2$  on  $Y'Y$ .

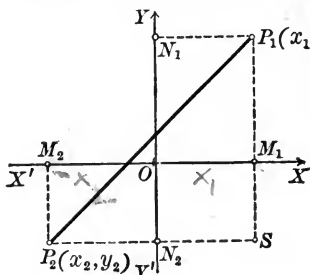

But by (1), p. 17,

$$M_1M_2 = OM_2 - OM_1 = x_2 - x_1,$$

$$N_1N_2 = ON_2 - ON_1 = y_2 - y_1.$$

Hence

**Theorem III.** Given any two points  $P_1(x_1, y_1), P_2(x_2, y_2)$ ; then

$$(III) \quad \begin{cases} x_2 - x_1 = \text{projection of } P_1P_2 \text{ on } X'X; \\ y_2 - y_1 = \text{projection of } P_1P_2 \text{ on } Y'Y. \end{cases}$$

We may now easily prove the important

**Theorem IV.** The length  $l$  of the line joining two points  $P_1(x_1, y_1), P_2(x_2, y_2)$  is given by the formula

$$(IV) \quad l = \sqrt{(x_1 - x_2)^2 + (y_1 - y_2)^2}.$$

*Proof.* Draw lines through  $P_1$  and  $P_2$  parallel to the axes to form the right triangle  $P_1SP_2$ .

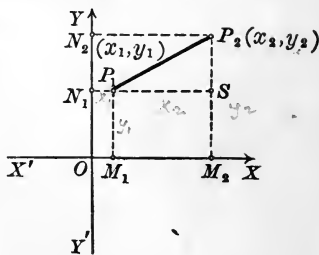

Then

$$SP_1 = M_2M_1 = x_1 - x_2, \quad (\text{by III})$$

$$P_2S = N_2N_1 = y_1 - y_2, \quad (\text{by III})$$

$$P_1P_2 = \sqrt{P_2S^2 + SP_1^2};$$

and hence

$$l = \sqrt{(x_1 - x_2)^2 + (y_1 - y_2)^2}.$$

Q.E.D.

*Handwritten signature*

The method used in deriving (IV) for *any* positions of  $P_1$  and  $P_2$  is the following :

Construct a right triangle by drawing lines parallel to the axes through  $P_1$  and  $P_2$ . The sides of this triangle are equal to the projections of the length  $P_1P_2$  upon the axes. But these projections are always given by (III), or by (III) with one or both signs changed. The required length is then the square root of the sum of the *squares* of these projections, so that the change in sign mentioned may be neglected. A number of different figures should be drawn to make the method clear.

**Ex. 1.** Find the length of the line joining the points (1, 3) and (-5, 5).

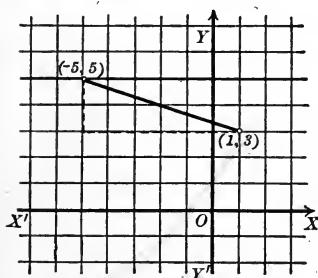

*Solution.* Call (1, 3)  $P_1$ , and (-5, 5)  $P_2$ .

Then

$$x_1 = 1, y_1 = 3, \text{ and } x_2 = -5, y_2 = 5;$$

and substituting in (IV), we have

$$l = \sqrt{(1 + 5)^2 + (3 - 5)^2} = \sqrt{40} = 2\sqrt{10}.$$

It should be noticed that we are simply finding the hypotenuse of a right triangle whose sides are 6 and 2.

*Remark.* The fact that formulas (III) and (IV) are true for *all* positions of the points  $P_1$  and  $P_2$  is of fundamental importance. The application of these formulas to any given problem is therefore simply a matter of direct substitution, as the example worked out above illustrates. In deriving such general formulas, since it is immaterial in what quadrants the assumed points lie, it is most convenient to draw the figure so that the points lie in the first quadrant, or, in general, so that *all the quantities assumed as known shall be positive.*

### PROBLEMS

1. Find the projections on the axes and the length of the lines joining the following points:

(a) (-4, -4) and (1, 3). *Ans.* Projections 5, 7; length =  $\sqrt{74}$ .

(b)  $(-\sqrt{2}, \sqrt{3})$  and  $(\sqrt{3}, \sqrt{2})$ .

*Ans.* Projections  $\sqrt{3} + \sqrt{2}, \sqrt{2} - \sqrt{3}$ ; length =  $\sqrt{10}$ .

(c)  $(0, 0)$  and  $\left(\frac{a}{2}, \frac{a\sqrt{3}}{2}\right)$ . *Ans.* Projections  $\frac{a}{2}, \frac{a}{2}\sqrt{3}$ ; length =  $a$ .

(d)  $(a + b, c + a)$  and  $(c + a, b + c)$ .

*Ans.* Projections  $c - b, b - a$ ; length =  $\sqrt{(b - c)^2 + (a - b)^2}$ .

2. Find the projections of the sides of the following triangles upon the axes:

(a)  $(0, 6), (1, 2), (3, -5)$ .

(b)  $(1, 0), (-1, -5), (-1, -8)$ .

(c)  $(a, b), (b, c), (c, d)$ .

3. Find the lengths of the sides of the triangles in problem 2.

4. Work out formulas (III) and (IV), (a) if  $x_1 = x_2$ ; (b) if  $y_1 = y_2$ .

5. Find the lengths of the sides of the triangle whose vertices are  $(4, 3), (2, -2), (-3, 5)$ .

6. Show that the points  $(1, 4), (4, 1), (5, 5)$  are the vertices of an isosceles triangle.

7. Show that the points  $(2, 2), (-2, -2), (2\sqrt{3}, -2\sqrt{3})$  are the vertices of an equilateral triangle.

8. Show that  $(3, 0), (6, 4), (-1, 3)$  are the vertices of a right triangle. What is its area?

9. Prove that  $(-4, -2), (2, 0), (8, 6), (2, 4)$  are the vertices of a parallelogram. Also find the lengths of the diagonals.

10. Show that  $(11, 2), (6, -10), (-6, -5), (-1, 7)$  are the vertices of a square. Find its area.

11. Show that the points  $(1, 3), (2, \sqrt{6}), (2, -\sqrt{6})$  are equidistant from the origin, that is, show that they lie on a circle with its center at the origin and its radius  $\sqrt{10}$ .

12. Show that the diagonals of any rectangle are equal.

13. Find the perimeter of the triangle whose vertices are  $(a, b), (-a, b), (-a, -b)$ .

14. Find the perimeter of the polygon formed by joining the following points two by two in order:

$(6, 4), (4, -3), (0, -1), (-5, -4), (-2, 1)$ .

15. One end of a line whose length is 13 is the point  $(-4, 8)$ ; the ordinate of the other end is 3. What is its abscissa? *Ans.* 8 or  $-16$ .

16. What equation must the coördinates of the point  $(x, y)$  satisfy if its distance from the point  $(7, -2)$  is equal to 11?

17. What equation expresses algebraically the fact that the point  $(x, y)$  is equidistant from the points  $(2, 3)$  and  $(4, 5)$ ?

18. If the angle  $XOY$  (Fig., p. 17) equals  $\omega$ , show that the length of the line joining  $P_1(x_1, y_1)$  and  $P_2(x_2, y_2)$  is given by

$$l = \sqrt{(x_1 - x_2)^2 + (y_1 - y_2)^2 + 2(x_1 - x_2)(y_1 - y_2)\cos\omega}.$$

19. If  $\omega = \frac{\pi}{3}$ , find distance between the points  $(-3, 3)$  and  $(4, -2)$ .

*Ans.*  $\sqrt{39}$ .

20. If  $\omega = \frac{\pi}{3}$ , find the perimeter of the triangle whose vertices are  $(1, 3)$ ,  $(2, 7)$ ,  $(-4, -4)$ .

*Ans.*  $\sqrt{21} + \sqrt{223} + \sqrt{109}$ .

21. If  $\omega = \frac{\pi}{6}$ , find the perimeter of triangle  $(1, 2)$ ,  $(-2, -4)$ ,  $(3, -5)$ .

*Ans.*  $3\sqrt{5} + 2\sqrt{3} + \sqrt{26 - 5\sqrt{3}} + \sqrt{53 - 14\sqrt{3}}$ .

22. Prove that  $(6, 6)$ ,  $(7, -1)$ ,  $(0, -2)$ ,  $(-2, 2)$  lie on a circle whose center is at  $(3, 2)$ .

23. If  $\omega = \frac{3\pi}{4}$ , find the distance between  $(\sqrt{3}, \sqrt{2})$ ,  $(-\sqrt{2}, \sqrt{3})$ .

*Ans.*  $\sqrt{10 + \sqrt{2}}$ .

24. Show that the sum of the projections of the sides of a polygon upon either axis is zero if each side is given a direction established by passing continuously around the perimeter.

**Inclination and slope.** The inclination of a line is the angle between the axis of  $x$  and the line when the latter is given the upward direction (p. 21).

The **slope** of a line is the tangent of its inclination.

The inclination of a line will be denoted by  $\alpha, \alpha_1, \alpha_2, \alpha'$ , etc.; its slope by  $m, m_1, m_2, m'$ , etc., so that  $m = \tan \alpha$ ,  $m_1 = \tan \alpha_1$ , etc.

The inclination may be any angle from  $0$  to  $\pi$  inclusive (p. 21). The

slope may be any real number, since the tangent of an angle in the first two quadrants may be any number positive or negative. The slope of a line parallel to  $X'X$  is of course zero, since the inclination is  $0$  or  $\pi$ . For a line parallel to  $Y'Y$  the slope is infinite.

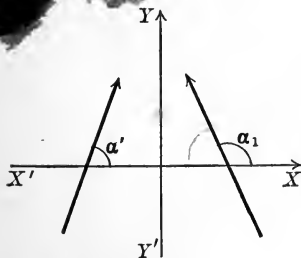

**Theorem V.** The slope  $m$  of the line passing through two points  $P_1(x_1, y_1)$ ,  $P_2(x_2, y_2)$  is given by

(V)

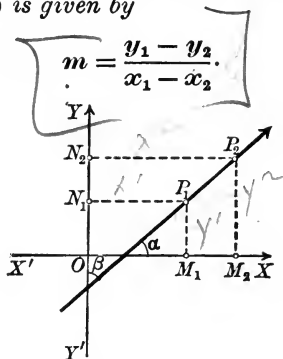
*Proof.*

$$M_1M_2 = x_2 - x_1 \quad (\text{by (III), p. 24})$$

$$= P_1P_2 \cos \alpha. \quad (\text{by (II), p. 23})$$

$$(1) \quad \therefore P_1P_2 \cos \alpha = x_2 - x_1.$$

Similarly,

$$N_1N_2 = y_2 - y_1 \quad (\text{by (III), p. 24})$$

$$= P_1P_2 \cos \beta. \quad (\text{by (II), p. 23})$$

$$(2) \quad \therefore P_1P_2 \cos \beta = y_2 - y_1.$$

But

$$\cos \beta = \sin \alpha. \quad (\text{by (I), p. 21})$$

Hence, from (2),

$$(3) \quad P_1P_2 \sin \alpha = y_2 - y_1.$$

$$\text{Dividing (3) by (1), } \tan \alpha = m = \frac{y_2 - y_1}{x_2 - x_1} = \frac{y_1 - y_2}{x_1 - x_2}. \quad \text{Q. E. D.}$$

*Remark.* Formula (V) may be verified by constructing a right triangle whose hypotenuse is  $P_1P_2$ , as on p. 24, whence  $\tan \alpha$  ( $= \tan \angle SP_1P_2$ ) is found directly as the ratio of the opposite side,  $SP_2 = y_2 - y_1$ , to the adjacent side,  $P_1S = x_2 - x_1$ .\*

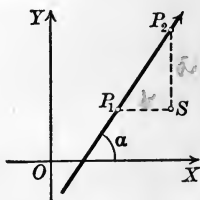

\* To construct a line passing through a given point  $P_1$  whose slope is a positive fraction  $\frac{a}{b}$ , we mark a point  $S$   $b$  units to the right of  $P_1$  and a point  $P_2$   $a$  units above  $S$ , and draw  $P_1P_2$ . If the slope is a negative fraction,  $-\frac{a}{b}$ , then either  $S$  must lie to the left of  $P_1$  or  $P_2$  must lie below  $S$ .



**Theorem VI.** *If two lines are parallel, their slopes are equal; if perpendicular, the slope of one is the negative reciprocal of the slope of the other, and conversely.*

*Proof.* Let  $\alpha_1$  and  $\alpha_2$  be the inclinations and  $m_1$  and  $m_2$  the slopes of the lines.

If the lines are parallel,  $\alpha_1 = \alpha_2$ .  $\therefore m_1 = m_2$ .

If the lines are perpendicular, as in the figure,

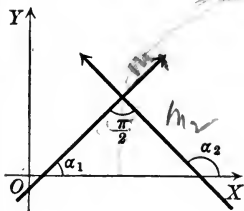

$$\alpha_2 = \alpha_1 + \frac{\pi}{2}, \text{ or } \alpha_1 = \alpha_2 - \frac{\pi}{2}.$$

$$\therefore m_1 = \tan \alpha_1 = \tan \left( \alpha_2 - \frac{\pi}{2} \right) = -\cot \alpha_2 \quad (\text{by 4 and 6, p. 12})$$

$$= -\frac{1}{\tan \alpha_2} \quad (\text{by 1, p. 12})$$

$$\therefore m_1 = -\frac{1}{m_2} \quad \text{Q.E.D.}$$

The converse is proved by retracing the steps with the assumption, in the second part, that  $\alpha_2$  is greater than  $\alpha_1$ .

**PROBLEMS**

$$m = \frac{7-2}{2-1} = 5$$

1. Find the slope of the line joining (1, 3) and (2, 7). Ans. 4.

2. Find the slope of the line joining (2, 7) and (-4, -4). Ans.  $\frac{11}{6}$ .

3. Find the slope of the line joining  $(\sqrt{3}, \sqrt{2})$  and  $(-\sqrt{2}, \sqrt{3})$ . Ans.  $2\sqrt{6} - 5$ .

4. Find the slope of the line joining  $(a + b, c + a)$ ,  $(c + a, b + c)$ . Ans.  $\frac{b-a}{c-b}$ .

5. Find the slopes of the sides of the triangle whose vertices are (1, 1), (-1, -1),  $(\sqrt{3}, -\sqrt{3})$ . Ans.  $\sqrt{1}, \frac{1+\sqrt{3}}{1-\sqrt{3}}, \frac{1-\sqrt{3}}{1+\sqrt{3}}$

6. Prove by means of slopes that (-4, -2), (2, 0), (8, 6), (2, 4) are the vertices of a parallelogram. (1, 1)  $\frac{1}{3}, \frac{1}{3}$   $\parallel$

7. Prove by means of slopes that (3, 0), (6, 4), (-1, 3) are the vertices of a right triangle.

8. Prove by means of slopes that (0, -2), (4, 2), (0, 6), (-4, 2) are the vertices of a rectangle, and hence, by (IV), of a square.

9. Prove by means of their slopes that the diagonals of the square in problem 8 are perpendicular.

10. Prove by means of slopes that  $(10, 0)$ ,  $(5, 5)$ ,  $(5, -5)$ ,  $(-5, 5)$  are the vertices of a trapezoid.

11. Show that the line joining  $(a, b)$  and  $(c, -d)$  is parallel to the line joining  $(-a, -b)$  and  $(-c, d)$ .

12. Show that the line joining the origin to  $(a, b)$  is perpendicular to the line joining the origin to  $(-b, a)$ .

13. What is the inclination of a line parallel to  $Y'Y$ ? perpendicular to  $Y'Y$ ?

14. What is the slope of a line parallel to  $Y'Y$ ? perpendicular to  $Y'Y$ ?

✓ 15. What is the inclination of the line joining  $(2, 2)$  and  $(-2, -2)$ ?

$$\text{Ans. } \frac{\pi}{4}$$

16. What is the inclination of the line joining  $(-2, 0)$  and  $(-5, 3)$ ?

$$\text{Ans. } \frac{3\pi}{4}$$

17. What is the inclination of the line joining  $(3, 0)$  and  $(4, \sqrt{3})$ ?

$$\text{Ans. } \frac{\pi}{3}$$

18. What is the inclination of the line joining  $(3, 0)$  and  $(2, \sqrt{3})$ ?

$$\text{Ans. } \frac{2\pi}{3}$$

19. What is the inclination of the line joining  $(0, -4)$  and  $(-\sqrt{3}, -5)$ ?

$$\text{Ans. } \frac{\pi}{6}$$

20. What is the inclination of the line joining  $(0, 0)$  and  $(-\sqrt{3}, 1)$ ?

$$\text{Ans. } \frac{5\pi}{6}$$

✓ 21. Prove by means of slopes that  $(2, 3)$ ,  $(1, -3)$ ,  $(3, 9)$  lie on the same straight line.

22. Prove that the points  $(a, b+c)$ ,  $(b, c+a)$ , and  $(c, a+b)$  lie on the same straight line.

23. Prove that  $(1, 5)$  is on the line joining the points  $(0, 2)$  and  $(2, 8)$  and is equidistant from them.

24. Prove that the line joining  $(3, -2)$  and  $(5, 1)$  is perpendicular to the line joining  $(10, 0)$  and  $(13, -2)$ .

**21. Point of division.** Let  $P_1$  and  $P_2$  be two fixed points on a directed line. Any third point on the line, as  $P$  or  $P'$ , is said

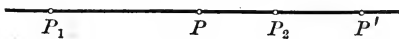

“to divide the line into two segments,” and is called a **point of division**. The division is called **internal** or **external** according as the point falls within or without  $P_1P_2$ . The position of the point of division depends upon the *ratio* of its distances from  $P_1$  and  $P_2$ . Since, however, the line is directed, some convention must be made as to the manner of reading these distances. We therefore adopt the rule:

If  $P$  is a point of division on a directed line passing through  $P_1$  and  $P_2$ , then  $P$  is said to divide  $P_1P_2$  into the segments  $P_1P$  and  $PP_2$ . The **ratio of division** is the value of the ratio\*  $\frac{P_1P}{PP_2}$ .

We shall denote this ratio by  $\lambda$ , that is,

$$\lambda = \frac{P_1P}{PP_2}$$

If the division is internal,  $P_1P$  and  $PP_2$  agree in direction and therefore in sign, and  $\lambda$  is therefore positive. In external division  $\lambda$  is negative. The *sign* of  $\lambda$  therefore indicates whether the point of division  $P$  is within or without the segment  $P_1P_2$ ; and the *numerical value* determines whether  $P$  lies nearer  $P_1$  or  $P_2$ . The distribution of  $\lambda$  is indicated in the figure.

*all these are -150 or so.*

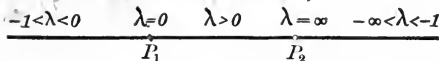

That is,  $\lambda$  may have any positive value between  $P_1$  and  $P_2$ , any negative value between 0 and  $-1$  to the left of  $P_1$ , and any negative value between  $-1$  and  $-\infty$  to the right of  $P_2$ . The value  $-1$  for  $\lambda$  is excluded.

\*To assist the memory in writing down this ratio, notice that the point of division  $P$  is written *last* in the numerator and *first* in the denominator.

Introducing coördinates, we next prove

**Theorem VII. Point of division.** *The coördinates  $(x, y)$  of the point of division  $P$  on the line joining  $P_1(x_1, y_1)$ ,  $P_2(x_2, y_2)$ , such that the ratio of the segments is*

$$\frac{P_1P}{PP_2} = \lambda,$$

are given by the formulas

$$(VII) \quad x = \frac{x_1 + \lambda x_2}{1 + \lambda}, \quad y = \frac{y_1 + \lambda y_2}{1 + \lambda}.$$

*Proof.* Given 
$$\lambda = \frac{P_1P}{PP_2}.$$

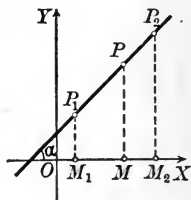

Let  $\alpha$  be the inclination of the line  $P_1P_2$ . Project  $P_1, P, P_2$  upon the axis of  $x$ .

Then, by the first theorem of projection [(II), p. 23],

$$M_1M = P_1P \cos \alpha,$$

$$MM_2 = PP_2 \cos \alpha.$$

Dividing, 
$$\frac{M_1M}{MM_2} = \frac{P_1P}{PP_2} = \lambda. \quad (\text{by hypothesis})$$

But 
$$\begin{aligned} M_1M &= x - x_1, \\ MM_2 &= x_2 - x. \end{aligned} \quad (\text{by (III), p. 24})$$

Substituting, 
$$\frac{x - x_1}{x_2 - x} = \lambda.$$

Clearing of fractions and solving for  $x$ ,

$$x = \frac{x_1 + \lambda x_2}{1 + \lambda}.$$

Similarly, 
$$y = \frac{y_1 + \lambda y_2}{1 + \lambda}.$$

Q.E.D.

**Corollary. Middle point.** *The coördinates  $(x, y)$  of the middle point of the line joining  $P_1(x_1, y_1)$ ,  $P_2(x_2, y_2)$  are found by taking the averages of the given abscissas and ordinates; that is,*

$$x = \frac{1}{2}(x_1 + x_2), \quad y = \frac{1}{2}(y_1 + y_2).$$

For if  $P$  is the middle point of  $P_1P_2$ , then  $\lambda = \frac{P_1P}{PP_2} = 1.$

**Ex. 1.** Find the point  $P$  dividing  $P_1(-1, -6)$ ,  $P_2(3, 0)$  in the ratio  $\lambda = -\frac{1}{2}$ .

*Solution.* Applying (VII),  $x_1 = -1$ ,  $y_1 = -6$ ,

$$x_2 = 3, y_2 = 0.$$

$$\therefore x = \frac{-1 - \frac{1}{2} \cdot 3}{1 - \frac{1}{2}} = \frac{-\frac{7}{2}}{\frac{1}{2}} = -2\frac{1}{2},$$

$$y = \frac{-6 - \frac{1}{2} \cdot 0}{1 - \frac{1}{2}} = \frac{-6}{\frac{1}{2}} = -8.$$

Hence  $P$  is  $(-2\frac{1}{2}, -8)$ . *Ans.*

**Ex. 2.** Find the coördinates of the point of intersection of the medians of a triangle whose vertices are  $(x_1, y_1)$ ,  $(x_2, y_2)$ ,  $(x_3, y_3)$ .

*Solution.* By Plane Geometry we have to find

the point  $P$  on the median  $AD$  such that  $AP = \frac{2}{3}AD$ , that is,  $AP : PD :: 2 : 1$ , or  $\lambda = 2$ .

By the Corollary,  $D$  is  $[\frac{1}{2}(x_2 + x_3), \frac{1}{2}(y_2 + y_3)]$ .

To find  $P$ , apply (VII), remembering that  $A$  corresponds to  $(x_1, y_1)$  and  $D$  to  $(x_2, y_2)$ .

$$\text{This gives } x = \frac{x_1 + 2 \cdot \frac{1}{2}(x_2 + x_3)}{1 + 2},$$

$$y = \frac{y_1 + 2 \cdot \frac{1}{2}(y_2 + y_3)}{1 + 2}.$$

$$\therefore x = \frac{1}{3}(x_1 + x_2 + x_3), y = \frac{1}{3}(y_1 + y_2 + y_3). \text{ } \textit{Ans.}$$

Hence the abscissa of the intersection of the medians of a triangle is the average of the abscissas of the vertices, and similarly for the ordinate.

The *symmetry* of these answers is evidence that the particular median chosen is immaterial, and the *formulas therefore prove the fact of the intersection of the medians.*

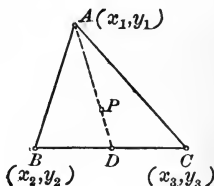

**PROBLEMS**

1. Find the coördinates of the middle point of the line joining  $(4, -6)$  and  $(-2, -4)$ . *Ans.*  $(1, -5)$ .
2. Find the coördinates of the middle point of the line joining  $(a+b, c+d)$  and  $(a-b, d-c)$ . *Ans.*  $(a, d)$ .
3. Find the middle points of the sides of the triangle whose vertices are  $(2, 3)$ ,  $(4, -5)$ , and  $(-3, -6)$ ; also find the lengths of the medians.
4. Find the coördinates of the point which divides the line joining  $(-1, 4)$  and  $(-5, -8)$  in the ratio  $1 : 3$ . *Ans.*  $(-2, 1)$ .
5. Find the coördinates of the point which divides the line joining  $(-3, -5)$  and  $(6, 9)$  in the ratio  $2 : 5$ . *Ans.*  $(-\frac{3}{7}, -1)$ .

6. Find the coördinates of the point which divides the line joining  $(2, 6)$  and  $(-4, 8)$  into segments whose ratio is  $-\frac{4}{3}$ . *Ans.*  $(-22, 14)$ .

7. Find the coördinates of the point which divides the line joining  $(-3, -4)$  and  $(5, 2)$  into segments whose ratio is  $-\frac{2}{3}$ . *Ans.*  $(-19, -16)$ .

8. Find the coördinates of the points which trisect the line joining the points  $(-2, -1)$  and  $(3, 2)$ . *Ans.*  $(-\frac{1}{3}, 0)$ ,  $(\frac{2}{3}, 1)$ .

9. Prove that the middle point of the hypotenuse of a right triangle is equidistant from the three vertices.

10. Show that the diagonals of the parallelogram whose vertices are  $(1, 2)$ ,  $(-5, -3)$ ,  $(7, -6)$ ,  $(1, -11)$  bisect each other.

11. Prove that the diagonals of any parallelogram mutually bisect each other.

12. Show that the lines joining the middle points of the opposite sides of the quadrilateral whose vertices are  $(6, 8)$ ,  $(-4, 0)$ ,  $(-2, -6)$ ,  $(4, -4)$  bisect each other.

13. In the quadrilateral of problem 12 show by means of slopes that the lines joining the middle points of the adjacent sides form a parallelogram.

14. Show that in the trapezoid whose vertices are  $(-8, 0)$ ,  $(-4, -4)$ ,  $(-4, 4)$ , and  $(4, -4)$  the length of the line joining the middle points of the non-parallel sides is equal to one half the sum of the lengths of the parallel sides. Also prove that it is parallel to the parallel sides.

15. In what ratio does the point  $(-2, 3)$  divide the line joining the points  $(-3, 5)$  and  $(4, -9)$ ? *Ans.*  $\frac{1}{6}$ .

16. In what ratio does the point  $(16, 3)$  divide the line joining the points  $(-5, 0)$  and  $(2, 1)$ ? *Ans.*  $-\frac{3}{2}$ .

17. Given the triangle whose vertices are  $(-5, 3)$ ,  $(1, -3)$ ,  $(7, 5)$ ; show that a line joining the middle points of any two sides is parallel to the third side and equal to one half of it.

18. If  $(2, 1)$ ,  $(3, 3)$ ,  $(6, 2)$  are the middle points of the sides of a triangle, what are the coördinates of the vertices of the triangle?

*Ans.*  $(-1, 2)$ ,  $(5, 0)$ ,  $(7, 4)$ .

19. Three vertices of a parallelogram are  $(1, 2)$ ,  $(-5, -3)$ ,  $(7, -6)$ . What are the coördinates of the fourth vertex?

*Ans.*  $(1, -11)$ ,  $(-11, 5)$ , or  $(13, -1)$ .

20. The middle point of a line is  $(6, 4)$ , and one end of the line is  $(5, 7)$ . What are the coördinates of the other end? *Ans.*  $(7, 1)$ .

21. The vertices of a triangle are  $(2, 3)$ ,  $(4, -5)$ ,  $(-3, -6)$ . Find the coördinates of the point where the medians intersect (center of gravity).

22. Find the area of the isosceles triangle whose vertices are (1, 5), (5, 1), (-9, -9) by finding the lengths of the base and altitude.

23. A line  $AB$  is produced to  $C$  so that  $BC = \frac{1}{2} AB$ . If the points  $A$  and  $B$  have the coördinates (5, 6) and (7, 2) respectively, what are the coördinates of  $C$ ? Ans. (8, 0).

24. Show that formula (VII) holds for oblique coördinates, that is,  $\angle XOY$  may have any value.

25. How far is the point bisecting the line joining the points (5, 5) and (3, 7) from the origin? What is the slope of this last line? Ans.  $2\sqrt{13}, \frac{2}{3}$ .

**22. Areas.** In this section the problem of determining the area of any polygon the coördinates of whose vertices are given will be solved. We begin with

**Theorem VIII.** *The area of a triangle whose vertices are the origin,  $P_1(x_1, y_1)$ , and  $P_2(x_2, y_2)$  is given by the formula*

(VIII) **Area of triangle  $OP_1P_2 = \frac{1}{2}(x_1y_2 - x_2y_1)$ .**

*Proof.* In the figure let

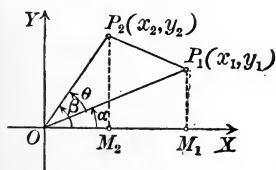

(1)  $\therefore \theta = \beta - \alpha$ .

$\alpha = \angle XOP_1,$

$\beta = \angle XOP_2,$

$\theta = \angle P_1OP_2.$

By 18, p. 13,

(2)  $\text{Area } \triangle OP_1P_2 = \frac{1}{2} OP_1 \cdot OP_2 \sin \theta$   
 $= \frac{1}{2} OP_1 \cdot OP_2 \sin(\beta - \alpha)$  [by (1)]

(3)  $= \frac{1}{2} OP_1 \cdot OP_2 (\sin \beta \cos \alpha - \cos \beta \sin \alpha)$ .  
(by 9, p. 13)

But in the figure

$\sin \beta = \frac{M_2P_2}{OP_2} = \frac{y_2}{OP_2}, \cos \beta = \frac{OM_2}{OP_2} = \frac{x_2}{OP_2},$

$\sin \alpha = \frac{M_1P_1}{OP_1} = \frac{y_1}{OP_1}, \cos \alpha = \frac{OM_1}{OP_1} = \frac{x_1}{OP_1}.$

Substituting in (3) and reducing, we obtain

$\text{Area } \triangle OP_1P_2 = \frac{1}{2}(x_1y_2 - x_2y_1).$

**Ex. 1.** Find the area of the triangle whose vertices are the origin,  $(-2, 4)$ , and  $(-5, -1)$ .

*Solution.* Denote  $(-2, 4)$  by  $P_1$ ,  $(-5, -1)$  by  $P_2$ .  
Then

$$x_1 = -2, \quad y_1 = 4, \quad x_2 = -5, \quad y_2 = -1.$$

Substituting in (VIII),

$$\text{Area} = \frac{1}{2}[-2 \cdot -1 - (-5) \cdot 4] = 11.$$

Then Area = 11 unit squares.

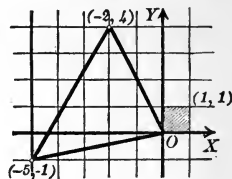

If, however, the formula (VIII) is applied by denoting  $(-2, 4)$  by  $P_2$ , and  $(-5, -1)$  by  $P_1$ , the result will be  $-11$ .

The two figures are as follows:

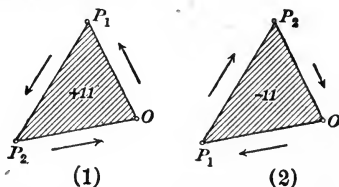

The cases of *positive* and *negative* area are distinguished by  
**Theorem IX.** *Passing around the perimeter in the order of the vertices  $O, P_1, P_2$ ,*

*if the area is on the left, as in Fig. 1, then (VIII) gives a positive result;*

*if the area is on the right, as in Fig. 2, then (VIII) gives a negative result.*

*Proof.* In the formula

$$(4) \quad \text{Area } \triangle OP_1P_2 = \frac{1}{2} OP_1 \cdot OP_2 \sin \theta$$

the angle  $\theta$  is measured from  $OP_1$  to  $OP_2$  within the triangle.

Hence  $\theta$  is positive when the area lies to the left in passing around the perimeter  $O, P_1, P_2$ , as in Fig. 1, since  $\theta$  is then measured counter-clockwise (p. 11).

But in Fig. 2,  $\theta$  is measured clockwise.

Hence  $\theta$  is *negative* and  $\sin \theta$  in (4) is also negative.

Q. E. D.

Formula (VIII) is easily applied to any polygon by regarding its area as made up of triangles with the origin as a common vertex. Consider any triangle.

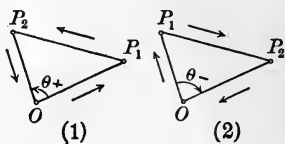



**Theorem X.** *The area of a triangle whose vertices are  $P_1(x_1, y_1)$ ,  $P_2(x_2, y_2)$ ,  $P_3(x_3, y_3)$  is given by*

$$(X) \text{ Area } \triangle P_1P_2P_3 = \frac{1}{2}(x_1y_2 - x_2y_1 + x_2y_3 - x_3y_2 + x_3y_1 - x_1y_3).$$

*This formula gives a positive or negative result according as the area lies to the left or right in passing around the perimeter in the order  $P_1P_2P_3$ .*

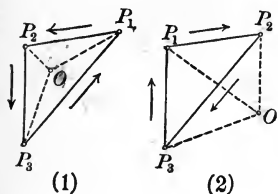

*Proof.* Two cases must be distinguished according as the origin is within or without the triangle.

Fig. 1, *origin within the triangle.*  
By inspection,

$$(5) \text{ Area } \triangle P_1P_2P_3 = \triangle OP_1P_2 + \triangle OP_2P_3 + \triangle OP_3P_1,$$

since these areas all have the *same sign*.

Fig. 2, *origin without the triangle.* By inspection,

$$(6) \text{ Area } \triangle P_1P_2P_3 = \triangle OP_1P_2 + \triangle OP_2P_3 + \triangle OP_3P_1,$$

since  $OP_1P_2$ ,  $OP_3P_1$  have the *same sign*, but  $OP_2P_3$  the opposite sign, the *algebraic sum* giving the desired area.

$$\text{By (VIII), } \triangle OP_1P_2 = \frac{1}{2}(x_1y_2 - x_2y_1),$$

$$\triangle OP_2P_3 = \frac{1}{2}(x_2y_3 - x_3y_2), \quad \triangle OP_3P_1 = \frac{1}{2}(x_3y_1 - x_1y_3).$$

Substituting in (5) and (6), we have (X).

Also in (5) the area is positive, in (6) negative.

Q. E. D.

An easy way to apply (X) is given by the following

**Rule for finding the area of a triangle.**

*First step.* Write down the vertices in two columns,  $x_1 \ y_1$   
 $x_2 \ y_2$   
 $x_3 \ y_3$   
abscissas in one, ordinates in the other, repeating the  
coördinates of the first vertex.  $x_1 \ y_1$

*Second step.* Multiply each abscissa by the ordinate of the next row, and add results. This gives  $x_1y_2 + x_2y_3 + x_3y_1$ .

*Third step.* Multiply each ordinate by the abscissa of the next row, and add results. This gives  $y_1x_2 + y_2x_3 + y_3x_1$ .

*Fourth step.* Subtract the result of the third step from that of the second step, and divide by 2. This gives the required area, namely, formula (X).

It is easy to show in the same manner that the rule applies to any polygon, if the following caution be observed in the first step:

*Write down the coördinates of the vertices in an order agreeing with that established by passing continuously around the perimeter, and repeat the coördinates of the first vertex.*

**Ex. 2.** Find the area of the quadrilateral whose vertices are (1, 6), (-3, -4), (2, -2), (-1, 3).

*Solution.* Plotting, we have the figure from which we choose the *order* of the vertices as indicated by the arrows. Following the rule:

First step. Write down the vertices in order.

Second step. Multiply each abscissa by the ordinate of the next row, and add. This gives

$$1 \times 3 + (-1 \times -4) + (-3 \times -2) + 2 \times 6 = 25.$$

Third step. Multiply each ordinate by the abscissa of the next row and add. This gives

$$6 \times -1 + 3 \times -3 + (-4 \times 2) + (-2 \times 1) = -25.$$

Fourth step. Subtract the result of the third step from the result of the second step, and divide by 2.

$$\therefore \text{Area} = \frac{25 + 25}{2} = 25 \text{ unit squares. } \text{Ans.}$$

The result has the positive sign, since the area is on the *left*.

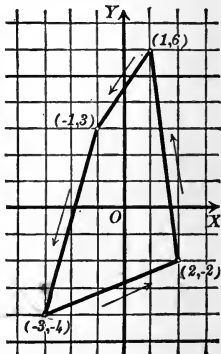

### PROBLEMS

- Find the area of the triangle whose vertices are (2, 3), (1, 5), (-1, -2).  
*Ans.*  $\frac{11}{2}$ .
- Find the area of the triangle whose vertices are (2, 3), (4, -5), (-3, -6).  
*Ans.* 29.
- Find the area of the triangle whose vertices are (8, 3), (-2, 3), (4, -5).  
*Ans.* 40.
- Find the area of the triangle whose vertices are (a, 0), (-a, 0), (0, b).  
*Ans.* ab.
- Find the area of the triangle whose vertices are (0, 0), (x<sub>1</sub>, y<sub>1</sub>), (x<sub>2</sub>, y<sub>2</sub>).  
*Ans.*  $\frac{x_1 y_2 - x_2 y_1}{2}$ .

6. Find the area of the triangle whose vertices are  $(a, 1)$ ,  $(0, b)$ ,  $(c, 1)$ .

$$\text{Ans. } \frac{(a - c)(b - 1)}{2}.$$

7. Find the area of the triangle whose vertices are  $(a, b)$ ,  $(b, a)$ ,  $(c, -c)$ .

$$\text{Ans. } \frac{1}{2}(a^2 - b^2).$$

8. Find the area of the triangle whose vertices are  $(3, 0)$ ,  $(0, 3\sqrt{3})$ ,  $(6, 3\sqrt{3})$ .

$$\text{Ans. } 9\sqrt{3}.$$

9. Prove that the area of the triangle whose vertices are the points  $(2, 3)$ ,  $(5, 4)$ ,  $(-4, 1)$  is zero, and hence that these points all lie on the same straight line.

10. Prove that the area of the triangle whose vertices are the points  $(a, b + c)$ ,  $(b, c + a)$ ,  $(c, a + b)$  is zero, and hence that these points all lie on the same straight line.

11. Prove that the area of the triangle whose vertices are the points  $(a, c + a)$ ,  $(-c, 0)$ ,  $(-a, c - a)$  is zero, and hence that these points all lie on the same straight line.

12. Find the area of the quadrilateral whose vertices are  $(-2, 3)$ ,  $(-3, -4)$ ,  $(5, -1)$ ,  $(2, 2)$ .

$$\text{Ans. } 31.$$

13. Find the area of the pentagon whose vertices are  $(1, 2)$ ,  $(3, -1)$ ,  $(6, -2)$ ,  $(2, 5)$ ,  $(4, 4)$ .

$$\text{Ans. } 18.$$

14. Find the area of the parallelogram whose vertices are  $(10, 5)$ ,  $(-2, 5)$ ,  $(-5, -3)$ ,  $(7, -3)$ .

$$\text{Ans. } 96.$$

15. Find the area of the quadrilateral whose vertices are  $(0, 0)$ ,  $(5, 0)$ ,  $(9, 11)$ ,  $(0, 3)$ .

$$\text{Ans. } 41.$$

16. Find the area of the quadrilateral whose vertices are  $(7, 0)$ ,  $(11, 9)$ ,  $(0, 5)$ ,  $(0, 0)$ .

$$\text{Ans. } 59.$$

17. Show that the area of the triangle whose vertices are  $(4, 6)$ ,  $(2, -4)$ ,  $(-4, 2)$  is four times the area of the triangle formed by joining the middle points of the sides.

18. Show that the lines drawn from the vertices  $(3, -8)$ ,  $(-4, 6)$ ,  $(7, 0)$  to the medial point of the triangle divide it into three triangles of equal area.

19. Given the quadrilateral whose vertices are  $(0, 0)$ ,  $(6, 8)$ ,  $(10, -2)$ ,  $(4, -4)$ ; show that the area of the quadrilateral formed by joining the middle points of its adjacent sides is equal to one half the area of the given quadrilateral.

### 23. Second theorem of projection.

**Lemma I.** *If  $M_1, M_2, M_3$  are any three points on a directed line, then in all cases*

$$M_1M_3 = M_1M_2 + M_2M_3.$$

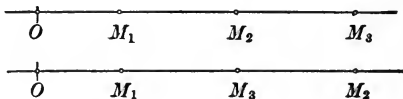

*Proof.* Let  $O$  be the origin.

By (1), p. 17,  $M_1M_2 = OM_2 - OM_1,$

$$M_2M_3 = OM_3 - OM_2.$$

Adding,  $M_1M_2 + M_2M_3 = OM_3 - OM_1.$

But by (1), p. 17,  $M_1M_3 = OM_3 - OM_1.$

$$\therefore M_1M_3 = M_1M_2 + M_2M_3.$$

Q.E.D.

This result is easily extended to prove

**Lemma II.** *If  $M_1, M_2, M_3, \dots, M_{n-1}, M_n$  are any  $n$  points on a directed line, then in all cases*

$$M_1M_n = M_1M_2 + M_2M_3 + M_3M_4 + \dots + M_{n-1}M_n,$$

*the lengths in the right-hand member being so written that the second point of each length is the first point of the next.*

The line joining the first and last points of a broken line is called the closing line.

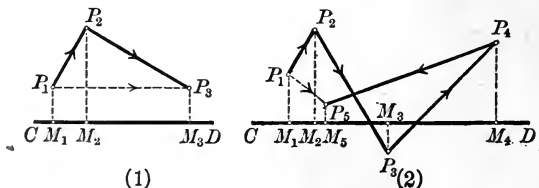

Thus in Fig. 1 the closing line is  $P_1P_3$ ; in Fig. 2 the closing line is  $P_1P_4$ .

**Theorem XI. Second theorem of projection.** *If each segment of a broken line be given the direction determined in passing continuously from one extremity to the other, then the algebraic sum of the projections of the segments upon any directed line equals the projection of the closing line.*

*Proof.* The proof results immediately from the Lemmas. For in Fig. 1

$$M_1M_2 = \text{projection of } P_1P_2;$$

$$M_2M_3 = \text{projection of } P_2P_3;$$

$$M_1M_3 = \text{projection of closing line } P_1P_3.$$

But by Lemma I

$$M_1M_2 + M_2M_3 = M_1M_3,$$

and the theorem follows.

Similarly in Fig. 2.

Q. E. D.

**Corollary.** *If the sides of a closed polygon be given the direction established by passing continuously around the perimeter, the sum of the projections of the sides upon any directed line is zero.*

For the closing line is now zero.

**Ex. 1.** Find the projection of the line joining the origin and  $(5, 3)$  upon a line passing through  $(-5, 0)$  whose inclination is  $\frac{\pi}{4}$ .

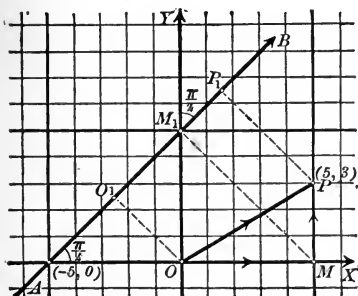

*Solution.* In the figure, applying the second theorem of projection,

$$\begin{aligned} \text{proj. of } OP \text{ on } AB &= \text{proj. of } OM + \text{proj. of } MP \\ &= OM \cos \frac{\pi}{4} + MP \cos \frac{\pi}{4} \end{aligned}$$

$$\begin{aligned} (\text{by first theorem of projection, p. 23}) \\ &= \frac{5}{2} \sqrt{2} + \frac{3}{2} \sqrt{2} = 4 \sqrt{2}. \text{ Ans.} \end{aligned}$$

The essential point in the solution of problems like Ex. 1 is the replacing of the given line, by means of Theorem XI, by a broken line with two segments which are parallel to the axes.

**Ex. 2.** Find the perpendicular distance from the line passing through  $(4, 0)$ , whose inclination is  $\frac{2\pi}{3}$ , to the point  $(10, 2)$ .

*Solution.* In the figure draw  $OC$  perpendicular to the given line  $AB$ .

$$\angle XAS = \frac{2\pi}{3}, \text{ or } 120^\circ.$$

$$\therefore \angle XOS = 30^\circ, \angle SOY = 60^\circ.$$

Required the perpendicular distance  $RP$ .

Project the broken line  $OMP$  upon  $OC$ . Then, by the second theorem of projection,

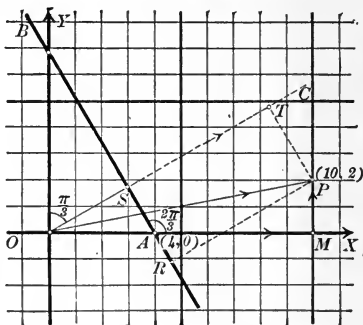

$$\begin{aligned} \text{proj. of } OP &= \text{proj. of } OM + \text{proj. of } MP \\ &= OM \cos \angle XOS + MP \cos \angle SOY \\ &= 10 \cdot \frac{1}{2} \sqrt{3} + 2 \cdot \frac{1}{2} \\ &= 1 + 5\sqrt{3}. \end{aligned}$$

(1)

But in the figure

$$\begin{aligned} \text{proj. of } OP &= OS + ST \\ &= OA \cos \angle XOS + RP \\ &= 4 \cdot \frac{1}{2} \sqrt{3} + RP. \end{aligned}$$

(2)

• From (1) and (2),

$$\begin{aligned} RP + 2\sqrt{3} &= 1 + 5\sqrt{3}. \\ RP &= 1 + 3\sqrt{3}. \quad \text{Ans.} \end{aligned}$$

### PROBLEMS

1. Four points lie on the axis of abscissas at distances of 1, 3, 6, and 10 respectively from the origin. Find  $P_1P_4$  by Lemma II.

2. A broken line joins continuously the points  $(-1, 4)$ ,  $(3, 6)$ ,  $(6, -2)$ ,  $(8, 1)$ ,  $(1, -1)$ . Show that the second theorem of projection holds when the segments are projected on the  $X$ -axis.

3. Show by means of a figure that the projection of the broken line joining the points  $(1, 2)$ ,  $(5, 4)$ ,  $(-1, -4)$ ,  $(3, -1)$ , and  $(1, 2)$  upon any line is zero.

4. Find the projection of the line joining the points  $(2, 1)$  and  $(5, 3)$  upon a line passing through the point  $(-1, 1)$  whose inclination is  $\frac{\pi}{6}$ .

$$\text{Ans. } \frac{3\sqrt{3} + 2}{2}.$$

5. What is the projection of the line joining these same points upon any line whose inclination is  $\frac{\pi}{6}$ ? Why?

6. Find the projection of the line joining the points  $(-1, 3)$  and  $(2, 4)$  upon a line whose inclination is  $\frac{3}{4}\pi$ . *Ans.*  $-\sqrt{2}$ .

7. Find the projection of the broken line joining the points  $(-1, 4)$ ,  $(3, 6)$ , and  $(5, 0)$  upon a line whose inclination is  $\frac{\pi}{4}$ . Verify your result by finding the projection of the closing line. *Ans.*  $\sqrt{2}$ .

8. Find the projection of the broken line joining  $(0, 0)$ ,  $(4, 2)$ , and  $(6, -3)$  upon a line whose inclination is  $\frac{2\pi}{3}$ . *Ans.*  $\frac{-6 - 3\sqrt{3}}{2}$ .

9. Show that the projection of the sides of the triangle  $(2, 1)$ ,  $(-1, 5)$ ,  $(-3, 1)$  upon a line whose inclination is  $\frac{\pi}{6}$  is zero.

10. Find the perpendicular distance from the point  $(6, 3)$  to a line passing through the point  $(-4, 0)$  with an inclination of  $\frac{\pi}{4}$ . *Ans.*  $\frac{7}{\sqrt{2}}$ .

11. Find the perpendicular distance from the point  $(-5, -1)$  to a line passing through the point  $(6, 0)$  and having an inclination of  $\frac{3}{4}\pi$ . *Ans.*  $6\sqrt{2}$ .

12. A line of inclination  $\frac{\pi}{6}$  passes through the point  $(5, 0)$ . Find the perpendicular distance to the parallel line passing through the point  $(0, 2)$ . *Ans.*  $\frac{5 + 2\sqrt{3}}{2}$ .

2

3  
2  
-9  
-0

## CHAPTER III

### THE CURVE AND THE EQUATION

**24. Locus of a point satisfying a given condition.** The curve\* (or group of curves) passing through all points which satisfy a given condition, and through no other points, is called the **locus** of the point satisfying that condition.

For example, in Plane Geometry, the following results are proved :

The perpendicular bisector of the line joining two fixed points is the locus of all points equidistant from these points.

The bisectors of the adjacent angles formed by two lines is the locus of all points equidistant from these lines.

To solve any locus problem involves two things :

1. To draw the locus by constructing a sufficient number of points satisfying the given condition and therefore lying on the locus.

2. To discuss the nature of the locus, that is, to determine properties of the curve.†

Analytic Geometry is peculiarly adapted to the solution of both parts of a locus problem.

**25. Equation of the locus of a point satisfying a given condition.** Let us take up the locus problem, making use of coördinates. If any point  $P$  satisfying the given condition and therefore lying on the locus be given the coördinates  $(x, y)$ , then the given condition will lead to an equation involving the variables  $x$  and  $y$ . The following example illustrates this fact, which is of fundamental importance.

\* The word "curve" will hereafter signify *any continuous line*, straight or curved.

† As the only loci considered in Elementary Geometry are straight lines and circles, the complete loci may be constructed by ruler and compasses, and the second part is relatively unimportant.



**Ex. 1.** Find the equation in  $x$  and  $y$  if the point whose locus is required shall be equidistant from  $A(-2, 0)$  and  $B(-3, 8)$ .

*Solution.* Let  $P(x, y)$  be any point on the locus. Then by the given condition

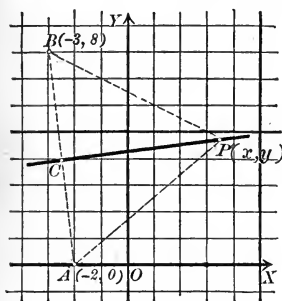

$$(1) \quad PA = PB.$$

But, by formula IV, p. 24,

$$PA = \sqrt{(x+2)^2 + (y-0)^2},$$

$$PB = \sqrt{(x+3)^2 + (y-8)^2}.$$

Substituting in (1),

$$(2) \quad \sqrt{(x+2)^2 + (y-0)^2}$$

$$= \sqrt{(x+3)^2 + (y-8)^2}.$$

Squaring and reducing,

$$(3) \quad 2x - 16y + 69 = 0.$$

In the equation (3),  $x$  and  $y$  are *variables* representing the coördinates of any point on the locus, that is, of any point on the perpendicular bisector of the line  $AB$ . This equation has two important and characteristic properties:

1. The coördinates of any point on the locus may be substituted for  $x$  and  $y$  in the equation (3), and the result will be true.

For let  $P_1(x_1, y_1)$  be any point on the locus. Then  $P_1A = P_1B$ , by definition. Hence, by formula IV, p. 24,

$$(4) \quad \sqrt{(x_1+2)^2 + y_1^2} = \sqrt{(x_1+3)^2 + (y_1-8)^2},$$

or, squaring and reducing,

$$(5) \quad 2x_1 - 16y_1 + 69 = 0.$$

Therefore  $x_1$  and  $y_1$  satisfy (3).

2. Conversely, every point whose coördinates satisfy (3) will lie upon the locus.

For if  $P_1(x_1, y_1)$  is a point whose coördinates satisfy (3), then (5) is true, and hence also (4) holds. Q. E. D.

In particular, the coördinates of the middle point  $C$  of  $A$  and  $B$ , namely,  $x = -2\frac{1}{2}$ ,  $y = 4$  (Corollary, p. 32), satisfy (3), since  $2(-2\frac{1}{2}) - 16 \times 4 + 69 = 0$ .

This example illustrates the following *correspondence* between Pure and Analytic Geometry as regards the locus problem:

#### *Locus problem*

##### *Pure Geometry*

The geometrical condition (satisfied by every point on the locus).

##### *Analytic Geometry*

An equation in the variables  $x$  and  $y$  representing coördinates (satisfied by the coördinates of every point on the locus).

This discussion leads to the fundamental definition :

The equation of the locus of a point satisfying a given condition is an equation in the variables  $x$  and  $y$  representing coördinates such that (1) the coördinates of every point on the locus will satisfy the equation; and (2) conversely, every point whose coördinates satisfy the equation will lie upon the locus.

This definition shows that the equation of the locus must be tested *in two ways* after derivation, as illustrated in the example of this section and in those following.

From the above definition follows at once the

**Corollary.** *A point lies upon a curve when and only when its coördinates satisfy the equation of the curve.*

**26. First fundamental problem.** *To find the equation of a curve which is defined as the locus of a point satisfying a given condition.*

The following rule will suffice for the solution of this problem in many cases :

**Rule.** *First step. Assume that  $P(x, y)$  is any point satisfying the given condition and is therefore on the curve.*

*Second step. Write down the given condition.*

*Third step. Express the given condition in coördinates and simplify the result. The final equation, containing  $x, y$ , and the given constants of the problem, will be the required equation.*

**Ex. 1.** Find the equation of the straight line passing through  $P_1(4, -1)$  and having an inclination of  $\frac{3\pi}{4}$ .

**Solution.** First step. Assume  $P(x, y)$  any point on the line.

Second step. The given condition, since the inclination  $\alpha$  is  $\frac{3\pi}{4}$ , may be written

$$(1) \quad \text{Slope of } P_1P = \tan \alpha = -1.$$

Third step. From (V), p. 28,

$$(2) \quad \text{Slope of } P_1P = \tan \alpha = \frac{y_1 - y_2}{x_1 - x_2} = \frac{y + 1}{x - 4}.$$

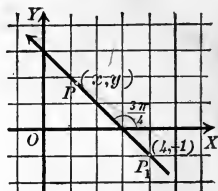

[By substituting  $(x, y)$  for  $(x_1, y_1)$ , and  $(4, -1)$  for  $(x_2, y_2)$ .]

∴ from (1),

$$\frac{y+1}{x-4} = -1,$$

or

$$(3) \quad x + y - 3 = 0. \quad \text{Ans.}$$

To prove that (3) is the required equation :

1. The coördinates  $(x_1, y_1)$  of any point on the line will satisfy (3), for the line joins  $(x_1, y_1)$  and  $(4, -1)$ , and its slope is  $-1$ ; hence, by (V), p. 28, substituting  $(4, -1)$  for  $(x_2, y_2)$ ,

$$-1 = \frac{y_1 + 1}{x_1 - 4}, \text{ or } x_1 + y_1 - 3 = 0,$$

and therefore  $x_1$  and  $y_1$  satisfy the equation (3).

2. Conversely, any point whose coördinates satisfy (3) is a point on the straight line. For if  $(x_1, y_1)$  is any such point, that is, if  $x_1 + y_1 - 3 = 0$ , then also  $-1 = \frac{y_1 + 1}{x_1 - 4}$  is true, and  $(x_1, y_1)$  is a point on the line passing through  $(4, -1)$  and having an inclination equal to  $\frac{3\pi}{4}$ . Q.E.D.

**Ex. 2.** Find the equation of a straight line parallel to the axis of  $y$  and at a distance of 6 units to the right.

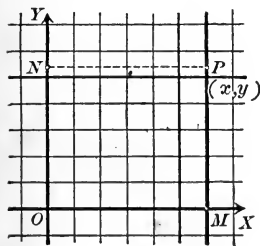

*Solution.* First step. Assume that  $P(x, y)$  is any point on the line, and draw  $NP$  perpendicular to  $OY$ .

Second step. The given condition may be written

$$(4) \quad NP = 6.$$

Third step. Since  $NP = OM = x$ , (4) becomes

$$(5) \quad x = 6. \quad \text{Ans.}$$

The equation (5) is the required equation :

1. The coördinates of every point satisfying the given condition may be substituted in (5). For if  $P_1(x_1, y_1)$  is any such point, then by the given condition  $x_1 = 6$ , that is,  $(x_1, y_1)$  satisfies (5).

2. Conversely, if the coördinates  $(x_1, y_1)$  satisfy (5), then  $x_1 = 6$ , and  $P_1(x_1, y_1)$  is at a distance of six units to the right of  $YY'$ . Q.E.D.

The method above illustrated of proving that the derived equation has the two characteristic properties of the equation of the locus should be carefully studied and applied to each of the following examples.

**Ex. 3.** Find the equation of the locus of a point whose distance from  $(-1, 2)$  is always equal to 4.

*Solution.* First step. Assume that  $P(x, y)$  is any point on the locus.

Second step. Denoting  $(-1, 2)$  by  $C$ , the given condition is

$$(6) \quad PC = 4.$$

Third step. By formula (IV), p. 24,

$$PC = \sqrt{(x+1)^2 + (y-2)^2}.$$

Substituting in (6),

$$\sqrt{(x+1)^2 + (y-2)^2} = 4.$$

Squaring and reducing,

$$(7) \quad x^2 + y^2 + 2x - 4y - 11 = 0.$$

This is the required equation, namely, the equation of the circle whose center is  $(-1, 2)$  and radius equals 4. The method of proof is the same as that of the preceding examples.

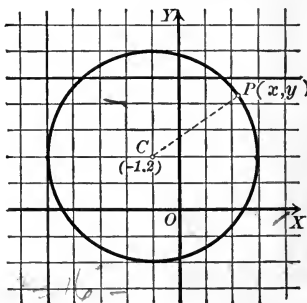

### PROBLEMS

- Find the equation of a line parallel to  $OY$  and
  - at a distance of 4 units to the right.
  - at a distance of 7 units to the left.
  - at a distance of 2 units to the right of  $(3, 2)$ .
  - at a distance of 5 units to the left of  $(2, -2)$ .
- What is the equation of a line parallel to  $OY$  and  $a - b$  units from it? How does this line lie relative to  $OY$  if  $a > b > 0$ ? if  $0 > b > a$ ?
- Find the equation of a line parallel to  $OX$  and
  - at a distance of 3 units above  $OX$ .
  - at a distance of 6 units below  $OX$ .
  - at a distance of 7 units above  $(-2, -3)$ .
  - at a distance of 5 units below  $(4, -2)$ .
- What is the equation of  $XX'$ ? of  $YY'$ ?
- Find the equation of a line parallel to the line  $x = 4$  and 3 units to the right of it. Eight units to the left of it.
- Find the equation of a line parallel to the line  $y = -2$  and 4 units below it. Five units above it.
- How does the line  $y = a - b$  lie if  $a > b > 0$ ? if  $b > a > 0$ ?
- What is the equation of the axis of  $x$ ? of the axis of  $y$ ?

9: What is the equation of the locus of a point which moves always at a distance of 2 units from the axis of  $x$ ? from the axis of  $y$ ? from the line  $x = -5$ ? from the line  $y = 4$ ?

10. What is the equation of the locus of a point which moves so as to be equidistant from the lines  $x = 5$  and  $x = 9$ ? equidistant from  $y = 3$  and  $y = -7$ ?

11. What are the equations of the sides of the rectangle whose vertices are  $(5, 2)$ ,  $(5, 5)$ ,  $(-2, 2)$ ,  $(-2, 5)$ ?

In problems 12 and 13,  $P_1$  is a given point on the required line,  $m$  is the slope of the line, and  $\alpha$  its inclination.

12. What is the equation of a line if

- (a)  $P_1$  is  $(0, 3)$  and  $m = -3$ ? *Ans.*  $3x + y - 3 = 0.$   
 (b)  $P_1$  is  $(-4, -2)$  and  $m = \frac{1}{3}$ ? *Ans.*  $x - 3y - 2 = 0.$   
 (c)  $P_1$  is  $(-2, 3)$  and  $m = \frac{\sqrt{2}}{2}$ ? *Ans.*  $\sqrt{2}x - 2y + 6 + 2\sqrt{2} = 0.$   
 (d)  $P_1$  is  $(0, 5)$  and  $m = \frac{\sqrt{3}}{2}$ ? *Ans.*  $\sqrt{3}x - 2y + 10 = 0.$   
 (e)  $P_1$  is  $(0, 0)$  and  $m = -\frac{2}{3}$ ? *Ans.*  $2x + 3y = 0.$   
 (f)  $P_1$  is  $(a, b)$  and  $m = 0$ ? *Ans.*  $y = b.$   
 (g)  $P_1$  is  $(-a, b)$  and  $m = \infty$ ? *Ans.*  $x = -a.$

13. What is the equation of a line if

- (a)  $P_1$  is  $(2, 3)$  and  $\alpha = 45^\circ$ ? *Ans.*  $x - y + 1 = 0.$   
 (b)  $P_1$  is  $(-1, 2)$  and  $\alpha = 45^\circ$ ? *Ans.*  $x - y + 3 = 0.$   
 (c)  $P_1$  is  $(-a, -b)$  and  $\alpha = 45^\circ$ ? *Ans.*  $x - y = b - a.$   
 (d)  $P_1$  is  $(5, 2)$  and  $\alpha = 60^\circ$ ? *Ans.*  $\sqrt{3}x - y + 2 - 5\sqrt{3} = 0.$   
 (e)  $P_1$  is  $(0, -7)$  and  $\alpha = 60^\circ$ ? *Ans.*  $\sqrt{3}x - y - 7 = 0.$   
 (f)  $P_1$  is  $(-4, 5)$  and  $\alpha = 0^\circ$ ? *Ans.*  $y = 5.$   
 (g)  $P_1$  is  $(2, -3)$  and  $\alpha = 90^\circ$ ? *Ans.*  $x = 2.$   
 (h)  $P_1$  is  $(3, -3\sqrt{3})$  and  $\alpha = 120^\circ$ ? *Ans.*  $\sqrt{3}x + y = 0.$   
 (i)  $P_1$  is  $(0, 3)$  and  $\alpha = 150^\circ$ ? *Ans.*  $\sqrt{3}x + 3y - 9 = 0.$   
 (j)  $P_1$  is  $(a, b)$  and  $\alpha = 135^\circ$ ? *Ans.*  $x + y = a + b.$

14. Are the points  $(3, 9)$ ,  $(4, 6)$ ,  $(5, 5)$  on the line  $3x + 2y = 25$ ?

15. Find the equation of the circle with

- (a) center at  $(3, 2)$  and radius = 4. *Ans.*  $x^2 + y^2 - 6x - 4y - 3 = 0.$   
 (b) center at  $(12, -5)$  and  $r = 13$ . *Ans.*  $x^2 + y^2 - 24x + 10y = 0.$   
 (c) center at  $(0, 0)$  and radius =  $r$ . *Ans.*  $x^2 + y^2 = r^2.$   
 (d) center at  $(0, 0)$  and  $r = 5$ . *Ans.*  $x^2 + y^2 = 25.$   
 (e) center at  $(3a, 4a)$  and  $r = 5a$ . *Ans.*  $x^2 + y^2 - 2a(3x + 4y) = 0.$   
 (f) center at  $(b + c, b - c)$  and  $r = c$ .  
*Ans.*  $x^2 + y^2 - 2(b + c)x - 2(b - c)y + 2b^2 + c^2 = 0.$

16. Find the equation of a circle whose center is  $(5, -4)$  and whose circumference passes through the point  $(-2, 3)$ .

17. Find the equation of a circle having the line joining  $(3, -5)$  and  $(-2, 2)$  as a diameter.

18. Find the equation of a circle touching each axis at a distance 6 units from the origin.

19. Find the equation of a circle whose center is the middle point of the line joining  $(-6, 8)$  to the origin and whose circumference passes through the point  $(2, 3)$ .

20. A point moves so that its distances from the two fixed points  $(2, -3)$  and  $(-1, 4)$  are equal. Find the equation of the locus and plot.

$$\text{Ans. } 3x - 7y + 2 = 0.$$

21. Find the equation of the perpendicular bisector of the line joining

(a)  $(2, 1), (-3, -3)$ .

$$\text{Ans. } 10x + 8y + 13 = 0.$$

(b)  $(3, 1), (2, 4)$ .

$$\text{Ans. } x - 3y + 5 = 0.$$

(c)  $(-1, -1), (3, 7)$ .

$$\text{Ans. } x + 2y - 7 = 0.$$

(d)  $(0, 4), (3, 0)$ .

$$\text{Ans. } 6x - 8y + 7 = 0.$$

(e)  $(x_1, y_1), (x_2, y_2)$ .

$$\text{Ans. } 2(x_1 - x_2)x + 2(y_1 - y_2)y + x_2^2 - x_1^2 + y_2^2 - y_1^2 = 0.$$

22. Show that in problem 21 the coordinates of the middle point of the line joining the given points satisfy the equation of the perpendicular bisector.

23. Find the equations of the perpendicular bisectors of the sides of the triangle  $(4, 8), (10, 0), (6, 2)$ . Show that they meet in the point  $(11, 7)$ .

24. Express by an equation that the point  $(h, k)$  is equidistant from  $(-1, 1)$  and  $(1, 2)$ ; also from  $(1, 2)$  and  $(1, -2)$ . Then show that the point  $(\frac{3}{2}, 0)$  is equidistant from  $(-1, 1), (1, 2), (1, -2)$ .

27. **General equations of the straight line and circle.** The methods illustrated in the preceding section enable us to state the following results:

1. A straight line parallel to the axis of  $y$  has an equation of the form  $x = \text{constant}$ .

2. A straight line parallel to the axis of  $x$  has an equation of the form  $y = \text{constant}$ .

**Theorem I.** *The equation of the straight line passing through a point  $B(0, b)$  on the axis of  $y$  and having its slope equal to  $m$  is*

(I)

$$y = mx + b.$$

*Proof.* First step. Assume that  $P(x, y)$  is any point on the line.

Second step. The given condition may be written

$$\text{Slope of } PB = m.$$

Third step. Since by Theorem V, p. 28,

$$\text{Slope of } PB = \frac{y - b}{x - 0},$$

[Substituting  $(x, y)$  for  $(x_1, y_1)$  and  $(0, b)$  for  $(x_2, y_2)$ ]

then

$$\frac{y - b}{x} = m, \text{ or } y = mx + b.$$

Q.E.D.

**Theorem II.** *The equation of the circle whose center is a given point  $(\alpha, \beta)$  and whose radius equals  $r$  is*

$$(II) \quad x^2 + y^2 - 2\alpha x - 2\beta y + \alpha^2 + \beta^2 - r^2 = 0.$$

*Proof.* First step. Assume that  $P(x, y)$  is any point on the locus.

Second step. If the center  $(\alpha, \beta)$  be denoted by  $C$ , the given condition is

$$PC = r.$$

Third step. By (IV), p. 24,

$$PC = \sqrt{(x - \alpha)^2 + (y - \beta)^2}.$$

$$\therefore \sqrt{(x - \alpha)^2 + (y - \beta)^2} = r.$$

Squaring and transposing, we have (II).

Q.E.D.

**Corollary.** *The equation of the circle whose center is the origin  $(0, 0)$  and whose radius is  $r$  is*

$$x^2 + y^2 = r^2.$$

The following facts should be observed :

Any straight line is defined by an equation of the *first degree* in the variables  $x$  and  $y$ .

Any circle is defined by an equation of the *second degree* in the variables  $x$  and  $y$ , in which *the terms of the second degree consist of the sum of the squares of  $x$  and  $y$ .*

**28. Locus of an equation.** The preceding sections have illustrated the fact that a locus problem in Analytic Geometry leads at once to an equation in the variables  $x$  and  $y$ . This equation having been found or being given, the complete solution of the locus problem requires two things, as already noted in the first section (p. 44) of this chapter, namely,

1. To draw the locus by plotting a sufficient number of points whose coördinates satisfy the given equation, and through which the locus therefore passes.

2. To discuss the nature of the locus, that is, to determine properties of the curve.

These two problems are respectively called :

1. Plotting the locus of an equation (second fundamental problem).

2. Discussing an equation (third fundamental problem).

For the present, then, we concentrate our attention upon some given equation in the variables  $x$  and  $y$  (one or both) and start out with the definition :

The **locus of an equation** in two variables representing coördinates is the curve or group of curves passing through all points whose coördinates satisfy that equation,\* and through such points only.

From this definition the truth of the following theorem is at once apparent :

**Theorem III.** *If the form of the given equation be changed in any way (for example, by transposition, by multiplication by a constant, etc.), the locus is entirely unaffected.*

\* An equation in the variables  $x$  and  $y$  is not necessarily satisfied by the coördinates of any points. For coördinates are *real* numbers, and the form of the equation may be such that it is satisfied by no real values of  $x$  and  $y$ . For example, the equation

$$x^2 + y^2 + 1 = 0$$

is of this sort, since, when  $x$  and  $y$  are real numbers,  $x^2$  and  $y^2$  are necessarily positive (or zero), and consequently  $x^2 + y^2 + 1$  is always a positive number greater than or equal to 1, and therefore *not* equal to zero. Such an equation therefore has *no locus*. The expression "the locus of the equation is imaginary" is also used.

An equation may be satisfied by the coördinates of a *finite* number of points only. For example,  $x^2 + y^2 = 0$  is satisfied by  $x = 0$ ,  $y = 0$ , but by no other real values. In this case the group of points, one or more, whose coördinates satisfy the equation, is called the locus of the equation.



We now take up in order the solution of the second and third fundamental problems.

### 29. Second fundamental problem.

**Rule to plot the locus of a given equation.**

*First step. Solve the given equation for one of the variables in terms of the other.\**

*Second step. By this formula compute the values of the variable for which the equation has been solved by assuming real values for the other variable.*

*Third step. Plot the points corresponding to the values so determined.†*

*Fourth step. If the points are numerous enough to suggest the general shape of the locus, draw a smooth curve through the points.*

Since there is no limit to the number of points which may be computed in this way, it is evident that the locus may be drawn as *accurately as may be desired* by simply plotting a sufficiently large number of points.

Several examples will now be worked out and the arrangement of the work should be carefully noted.

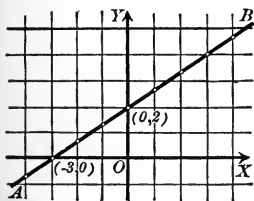

**Ex. 1.** Draw the locus of the equation

$$2x - 3y + 6 = 0.$$

*Solution.* First step. Solving for  $y$ ,

$$y = \frac{2}{3}x + 2.$$

Second step. Assume values for  $x$  and compute  $y$ , arranging results in the form :

$x$	$y$	$x$	$y$
0	2	0	2
1	$2\frac{2}{3}$	-1	$1\frac{1}{3}$
2	$3\frac{1}{3}$	-2	$\frac{2}{3}$
3	4	-3	0
4	$4\frac{2}{3}$	-4	$-\frac{2}{3}$
etc.	etc.	etc.	etc.

Thus, if

$$x = 1, y = \frac{2}{3} \cdot 1 + 2 = 2\frac{2}{3},$$

$$x = 2, y = \frac{2}{3} \cdot 2 + 2 = 3\frac{1}{3},$$

etc.

Third step. Plot the points found.

Fourth step. Draw a smooth curve through these points.

\* The form of the given equation will often be such that solving for one variable is simpler than solving for the other. *Always choose the simpler solution.*

† Remember that *real* values only may be used as coördinates.

**Ex. 2.** Plot the locus of the equation

$$y = x^2 - 2x - 3.$$

*Solution.* First step. The equation as given is solved for  $y$ .

Second step. Computing  $y$  by assuming values of  $x$ , we find the table of values below:

$x$	$y$	$x$	$y$
0	-3	0	-3
1	-4	-1	0
2	-3	-2	5
3	0	-3	12
4	5	-4	21
5	12	etc.	etc.
6	21		
etc.	etc.		

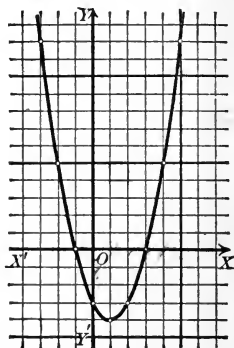

Third step. Plot the points.

Fourth step. Draw a smooth curve through these points. This gives the curve of the figure.

**Ex. 3.** Plot the locus of the equation

$$x^2 + y^2 + 6x - 16 = 0.$$

First step. Solving for  $y$ ,

$$y = \pm \sqrt{16 - 6x - x^2}.$$

Second step. Compute  $y$  by assuming values of  $x$ .

$x$	$y$	$x$	$y$
0	$\pm 4$	0	$\pm 4$
1	$\pm 3$	-1	$\pm 4.6$
2	0	-2	$\pm 4.9$
3	imag.	-3	$\pm 5$
4	"	-4	$\pm 4.9$
5	"	-5	$\pm 4.6$
6	"	-6	$\pm 4$
7	"	-7	$\pm 3$
		-8	0
		-9	imag.

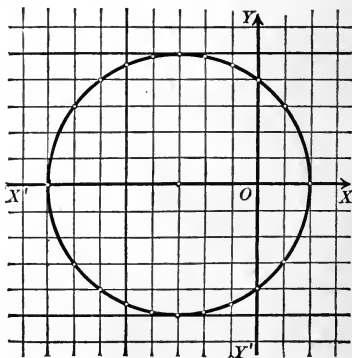

For example, if  $x = 1$ ,  $y = \pm \sqrt{16 - 6 - 1} = \pm 3$ ;

if  $x = 3$ ,  $y = \pm \sqrt{16 - 18 - 9} = \pm \sqrt{-11}$ ,

an imaginary number;

if  $x = -1$ ,  $y = \pm \sqrt{16 + 6 - 1} = \pm 4.6$ ,

etc.

Third step. Plot the corresponding points.

Fourth step. Draw a smooth curve through these points.

### PROBLEMS

1. Plot the locus of each of the following equations.

(a)  $x + 2y = 0$ .

(p)  $x^2 + y^2 = 9$ .

(b)  $x + 2y = 3$ .

(q)  $x^2 + y^2 = 25$ .

(c)  $3x - y + 5 = 0$ .

(r)  $x^2 + y^2 + 9x = 0$ .

(d)  $y = 4x^2$ .

(s)  $x^2 + y^2 + 4y = 0$ .

(e)  $x^2 + 4y = 0$ .

(t)  $x^2 + y^2 - 6x - 16 = 0$ .

(f)  $y = x^2 - 3$ .

(u)  $x^2 + y^2 - 6y - 16 = 0$ .

(g)  $x^2 + 4y - 5 = 0$ .

(v)  $4y = x^4 - 8$ .

(h)  $y = x^2 + x + 1$ .

(w)  $4x = y^4 + 8$ .

(i)  $x = y^2 + 2y - 3$ .

(j)  $4x = y^3$ .

(x)  $y = \frac{x}{1 + x^2}$ .

(k)  $4x = y^3 - 1$ .

(y)  $x = \frac{1 - y^2}{1 + y^2}$ .

(l)  $y = x^3 - 1$ .

(m)  $y = x^3 - x$ .

(n)  $y = x^3 - x^2 - 5$ .

(z)  $x = \frac{2}{1 + y^2}$ .

(o)  $x^2 + y^2 = 4$ .

2. Show that the following equations have *no locus* (footnote, p. 52).

(a)  $x^2 + y^2 + 1 = 0$ .

(f)  $x^2 + y^2 + 2x + 2y + 3 = 0$ .

(b)  $2x^2 + 3y^2 = -8$ .

(g)  $4x^2 + y^2 + 8x + 5 = 0$ .

(c)  $x^2 + 4 = 0$ .

(h)  $y^4 + 2x^2 + 4 = 0$ .

(d)  $x^4 + y^2 + 8 = 0$ .

(i)  $9x^2 + 4y^2 + 18x + 8y + 15 = 0$ .

(e)  $(x + 1)^2 + y^2 + 4 = 0$ .

(j)  $x^2 + xy + y^2 + 3 = 0$ .

*Hint.* Write each equation in the form of a sum of squares and reason as in the footnote on p. 52.

**30. Principle of comparison.** In Ex. 1, p. 53, and Ex. 3, p. 54, we can determine the nature of the locus, that is, *discuss the equation*, by making use of the formulas (I) and (II), p. 51. The method is important, and is known as the **principle of comparison**.

*The nature of the locus of a given equation may be determined by comparison with a general known equation, if the latter becomes identical with the given equation by assigning particular values to its coefficients.*

The method of making the comparison is explained in the following

**Rule.** *First step.* Change the form\* of the given equation (if necessary) so that one or more of its terms shall be identical with one or more terms of the general equation.

*Second step.* Equate coefficients of corresponding terms in the two equations, supplying any terms missing in the given equation with zero coefficients.

*Third step.* Solve the equations found in the second step for the values † of the coefficients of the general equation.

**Ex. 1.** Show that  $2x - 3y + 6 = 0$  is the equation of a straight line (Fig., p. 53).

*Solution.* First step. Compare with the general equation (I), p. 51,

$$(1) \quad y = mx + b.$$

Put the given equation in the form of (1) by solving for  $y$ ,

$$(2) \quad y = \frac{2}{3}x + 2.$$

Second step. The right-hand members are now identical. Equating coefficients of  $x$ ,

$$(3) \quad m = \frac{2}{3}.$$

Equating constant terms,

$$(4) \quad b = 2.$$

Third step. Equations (3) and (4) give the values of the coefficients  $m$  and  $b$ , and these are possible values, since, p. 27, the slope of a line may have any real value whatever, and of course the ordinate  $b$  of the point  $(0, b)$  in which a line crosses the  $Y$ -axis may also be any real number. Therefore the equation  $2x - 3y + 6 = 0$  represents a straight line passing through  $(0, 2)$  and having a slope equal to  $\frac{2}{3}$ . Q.E.D.

\* This transformation is called "putting the given equation in the form" of the general equation.

† The values thus found may be impossible (for example, imaginary) values. This may indicate one of two things, — that the given equation has no locus, or that it cannot be put in the form required.

**Ex. 2.** Show that the locus of

$$(5) \quad x^2 + y^2 + 6x - 16 = 0$$

is a circle (Fig., p. 54).

*Solution.* First step. Compare with the general equation (II), p. 51,

$$(6) \quad x^2 + y^2 - 2\alpha x - 2\beta y + \alpha^2 + \beta^2 - r^2 = 0.$$

The right-hand members of (5) and (6) agree, and also the first two terms,  $x^2 + y^2$ .

Second step. Equating coefficients of  $x$ ,

$$(7) \quad -2\alpha = 6.$$

Equating coefficients of  $y$ ,

$$(8) \quad -2\beta = 0.$$

Equating constant terms,

$$(9) \quad \alpha^2 + \beta^2 - r^2 = -16.$$

Third step. From (7) and (8),

$$\alpha = -3, \beta = 0.$$

Substituting these values in (9) and solving for  $r$ , we find

$$r^2 = 25, \text{ or } r = 5.$$

Since  $\alpha$ ,  $\beta$ ,  $r$  may be any real numbers whatever, the locus of (5) is a circle whose center is  $(-3, 0)$  and whose radius equals 5.

### PROBLEMS

1. Plot the locus of each of the following equations. Prove that the locus is a straight line in each case, and find the slope  $m$  and the point of intersection with the axis of  $y$ ,  $(0, b)$ .

(a)  $2x + y - 6 = 0.$  *Ans.*  $m = -2, b = 6.$

(b)  $x - 3y + 8 = 0.$  *Ans.*  $m = \frac{1}{3}, b = 2\frac{2}{3}.$

(c)  $x + 2y = 0.$  *Ans.*  $m = -\frac{1}{2}, b = 0.$

(d)  $5x - 6y - 5 = 0.$  *Ans.*  $m = \frac{5}{6}, b = -\frac{5}{6}.$

(e)  $\frac{1}{2}x - \frac{2}{3}y - \frac{1}{8} = 0.$  *Ans.*  $m = \frac{3}{4}, b = -\frac{3}{16}.$

(f)  $\frac{x}{5} - \frac{y}{6} - 1 = 0.$  *Ans.*  $m = \frac{6}{5}, b = -6.$

(g)  $7x - 8y = 0.$  *Ans.*  $m = \frac{7}{8}, b = 0.$

(h)  $\frac{3}{2}x - \frac{2}{3}y - \frac{7}{8} = 0.$  *Ans.*  $m = \frac{9}{4}, b = -1\frac{5}{8}.$

2. Plot the locus of each of the equations following, and prove that the locus is a circle, finding the center  $(\alpha, \beta)$  and the radius  $r$  in each case.

- |  |  |
|--|--|
| (a) $x^2 + y^2 - 16 = 0.$                    | <i>Ans.</i> $(\alpha, \beta) = (0, 0); r = 4.$                     |
| (b) $x^2 + y^2 - 49 = 0.$                    | <i>Ans.</i> $(\alpha, \beta) = (0, 0); r = 7.$                     |
| (c) $x^2 + y^2 - 25 = 0.$                    | <i>Ans.</i> $(\alpha, \beta) = (0, 0); r = 5.$                     |
| (d) $x^2 + y^2 + 4x = 0.$                    | <i>Ans.</i> $(\alpha, \beta) = (-2, 0); r = 2.$                    |
| (e) $x^2 + y^2 - 8y = 0.$                    | <i>Ans.</i> $(\alpha, \beta) = (0, 4); r = 4.$                     |
| (f) $x^2 + y^2 + 4x - 8y = 0.$               | <i>Ans.</i> $(\alpha, \beta) = (-2, 4); r = \sqrt{20}.$            |
| (g) $x^2 + y^2 - 6x + 4y - 12 = 0.$          | <i>Ans.</i> $(\alpha, \beta) = (3, -2); r = 5.$                    |
| (h) $x^2 + y^2 - 4x + 9y - \frac{3}{4} = 0.$ | <i>Ans.</i> $(\alpha, \beta) = (2, -\frac{9}{2}); r = 5.$          |
| (i) $3x^2 + 3y^2 - 6x - 8y = 0.$             | <i>Ans.</i> $(\alpha, \beta) = (1, \frac{4}{3}); r = \frac{5}{3}.$ |

The following problems illustrate cases in which the locus problem is *completely solved* by analytic methods, since the loci may be easily drawn and their nature determined.

3. Find the equation of the locus of a point whose distances from the axes  $XX'$  and  $YY'$  are in a constant ratio equal to  $\frac{2}{3}$ .

$$2x = 3y$$

*Ans.* The straight line  $2x - 3y = 0.$

4. Find the equation of the locus of a point the sum of whose distances from the axes of coördinates is always equal to 10.

$$x + y = 10$$

*Ans.* The straight line  $x + y - 10 = 0.$

5. A point moves so that the difference of the squares of its distances from  $(3, 0)$  and  $(0, -2)$  is always equal to 8. Find the equation of the locus and plot.

*Ans.* The parallel straight lines  $6x + 4y + 3 = 0, 6x + 4y - 13 = 0.$

6. A point moves so as to be always equidistant from the axes of coördinates. Find the equation of the locus and plot.

*Ans.* The perpendicular straight lines  $x + y = 0, x - y = 0.$

7. A point moves so as to be always equidistant from the straight lines  $x - 4 = 0$  and  $y + 5 = 0$ . Find the equation of the locus and plot.

*Ans.* The perpendicular straight lines  $x - y - 9 = 0, x + y + 1 = 0.$

8. Find the equation of the locus of a point the sum of the squares of whose distances from  $(3, 0)$  and  $(-3, 0)$  always equals 68. Plot the locus.

*Ans.* The circle  $x^2 + y^2 = 25.$

9. Find the equation of the locus of a point which moves so that its distances from  $(8, 0)$  and  $(2, 0)$  are always in a constant ratio equal to 2. Plot the locus.

*Ans.* The circle  $x^2 + y^2 = 16.$

10. A point moves so that the ratio of its distances from  $(2, 1)$  and  $(-4, 2)$  is always equal to  $\frac{1}{2}$ . Find the equation of the locus and plot.

*Ans.* The circle  $3x^2 + 3y^2 - 24x - 4y = 0.$

In the proofs of the following theorems the choice of the axes of coördinates is left to the student, since no mention is made of either coördinates or equations in the problem. In such cases always choose the axes in the most convenient manner possible.

11. A point moves so that the sum of its distances from two perpendicular lines is constant. Show that the locus is a straight line.

*Hint.* Choosing the axes of coördinates to coincide with the given lines, the equation is  $x + y = \text{constant}$ .

12. A point moves so that the difference of the squares of its distances from two fixed points is constant. Show that the locus is a straight line.

*Hint.* Draw  $XX'$  through the fixed points, and  $YY'$  through their middle point. Then the fixed points may be written  $(a, 0)$ ,  $(-a, 0)$ , and if the "constant difference" be denoted by  $k$ , we find for the locus  $4ax = k$  or  $4ax = -k$ .

13. A point moves so that the sum of the squares of its distances from two fixed points is constant. Prove that the locus is a circle.

*Hint.* Choose axes as in problem 12.

14. A point moves so that the ratio of its distances from two fixed points is constant. Determine the nature of the locus.

*Ans.* A circle if the constant ratio is not equal to unity and a straight line if it is.

The following problems illustrate the

**Theorem.** *If an equation can be put in the form of a product of variable factors equal to zero, the locus is found by setting each factor equal to zero and plotting the locus of each equation separately.*

15. Draw the locus of  $4x^2 - 9y^2 = 0$ .

*Solution.* Factoring,

$$(1) \quad (2x - 3y)(2x + 3y) = 0.$$

Then, by the theorem, the locus consists of the straight lines

$$(2) \quad 2x - 3y = 0,$$

$$(3) \quad 2x + 3y = 0.$$

*Proof.* 1. The coördinates of any point  $(x_1, y_1)$  which satisfy (1) will satisfy either (2) or (3).

For if  $(x_1, y_1)$  satisfies (1),

$$(4) \quad (2x_1 - 3y_1)(2x_1 + 3y_1) = 0.$$

This product can vanish only when one of the factors is zero. Hence either

$$2x_1 - 3y_1 = 0,$$

and therefore  $(x_1, y_1)$  satisfies (2);

or

$$2x_1 + 3y_1 = 0,$$

and therefore  $(x_1, y_1)$  satisfies (3).

2. A point  $(x_1, y_1)$  on either of the lines defined by (2) and (3) will also lie on the locus of (1).

For if  $(x_1, y_1)$  is on the line  $2x - 3y = 0$ , then (Corollary, p. 46)

$$(5) \quad 2x_1 - 3y_1 = 0.$$

Hence the product  $(2x_1 - 3y_1)(2x_1 + 3y_1)$  also vanishes, since by (5) the first factor is zero, and therefore  $(x_1, y_1)$  satisfies (1).

Therefore every point on the locus of (1) is also on the locus of (2) and (3), and conversely. This proves the theorem for this example. Q.E.D.

16. Show that the locus of each of the following equations is a pair of straight lines, and plot the lines.

(a)  $x^2 - y^2 = 0.$

(j)  $3x^2 + xy - 2y^2 + 6x - 4y = 0.$

(b)  $9x^2 - y^2 = 0.$

(k)  $x^2 - y^2 + x + y = 0.$

(c)  $x^2 = 9y^2.$

(l)  $x^2 - xy + 5x - 5y = 0.$

(d)  $x^2 - 4x - 5 = 0.$

(m)  $x^2 - 2xy + y^2 + 6x - 6y = 0.$

(e)  $y^2 - 6y = 7.$

(n)  $x^2 - 4y^2 + 5x + 10y = 0.$

(f)  $y^2 - 5xy + 6y = 0.$

(o)  $x^2 + 4xy + 4y^2 + 5x + 10y + 6 = 0.$

(g)  $xy - 2x^2 - 3x = 0.$

(p)  $x^2 + 3xy + 2y^2 + x + y = 0.$

(h)  $xy - 2x = 0.$

(q)  $x^2 - 4xy - 5y^2 + 2x - 10y = 0.$

(i)  $xy = 0.$

(r)  $3x^2 - 2xy - y^2 + 5x - 5y = 0.$

17. Show that the locus of  $Ax^2 + Bx + C = 0$  is a pair of parallel lines, a single line, or that there is no locus according as  $\Delta = B^2 - 4AC$  is positive, zero, or negative.

18. Show that the locus of  $Ax^2 + Bxy + Cy^2 = 0$  is a pair of intersecting lines, a single line, or a point according as  $\Delta = B^2 - 4AC$  is positive, zero, or negative.

### 31. Third fundamental problem. Discussion of an equation.

The method explained of solving the second fundamental problem gives no knowledge of the required curve except that it passes through all the points whose coördinates are determined as satisfying the given equation. Joining these points gives a curve more or less like the exact locus. Serious errors may be



made in this way, however, since *the nature of the curve between any two successive points plotted is not determined*. This objection is somewhat obviated by determining *before plotting* certain properties of the locus by a discussion of the given equation now to be explained.

The nature and properties of a locus depend upon the form of its equation, and hence the steps of any discussion must depend upon the particular problem. In every case, however, the following questions should be answered.

1. *Is the curve a closed curve or does it extend out infinitely far?*
2. *Is the curve symmetrical with respect to either axis or the origin?*

The method of deciding these questions is illustrated in the following examples.

Ex. 1. Plot the locus of

$$(1) \quad x^2 + 4y^2 = 16.$$

Discuss the equation.

*Solution.* First step. Solving for  $x$ ,

$$(2) \quad x = \pm 2\sqrt{4 - y^2}.$$

Second step. Assume values of  $y$  and compute  $x$ . This gives the table.

Third step. Plot the points of the table.

Fourth step. Draw a smooth curve through these points.

$x$	$y$	$x$	$y$
$\pm 4$	0	$\pm 4$	0
$\pm 3.4$	1	$\pm 3.4$	-1
$\pm 2.7$	$1\frac{1}{2}$	$\pm 2.7$	$-1\frac{1}{2}$
0	2	0	-2
imag.	3	imag.	-3

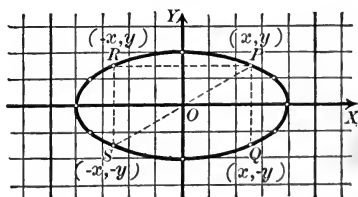

*Discussion.* 1. Equation (1) shows that neither  $x$  nor  $y$  can be indefinitely great, since  $x^2$  and  $4y^2$  are positive for all real values and their sum must equal 16. Therefore neither  $x^2$  nor  $4y^2$  can exceed 16. Hence *the curve is a closed curve*.

A second way of proving this is the following:

From (2), the ordinate  $y$  cannot exceed 2 nor be less than -2, since the expression  $4 - y^2$  beneath the radical must not be negative. (2) also shows that  $x$  has values only from -4 to 4 inclusive.

2. To determine the symmetry with respect to the axes we proceed as follows:

The equation (1) contains no odd powers of  $x$  or  $y$ ; hence it may be written in any one of the forms

$$(3) \quad (x)^2 + 4(-y)^2 = 16, \text{ replacing } (x, y) \text{ by } (x, -y);$$

$$(4) \quad (-x)^2 + 4(y)^2 = 16, \text{ replacing } (x, y) \text{ by } (-x, y);$$

$$(5) \quad (-x)^2 + 4(-y)^2 = 16, \text{ replacing } (x, y) \text{ by } (-x, -y).$$

The transformation of (1) into (3) corresponds in the figure to replacing each point  $P(x, y)$  on the curve by the point  $Q(x, -y)$ . But the points  $P$  and  $Q$  are symmetrical with respect to  $XX'$ , and (1) and (3) have the same locus (Theorem III, p. 52). Hence the locus of (1) is unchanged if each point is changed to a second point symmetrical to the first with respect to  $XX'$ . Therefore *the locus is symmetrical with respect to the axis of  $x$* . Similarly from (4), *the locus is symmetrical with respect to the axis of  $y$* , and from (5), *the locus is symmetrical with respect to the origin*.

The locus is called an ellipse.

Ex. 2. Plot the locus of

$$(6) \quad y^2 - 4x + 15 = 0.$$

Discuss the equation.

*Solution.* First step. Solve the equation for  $x$ , since a square root would have to be extracted if we solved for  $y$ . This gives

$$(7) \quad x = \frac{1}{4}(y^2 + 15).$$

$x$	$y$
$3\frac{3}{4}$	0
4	$\pm 1$
$4\frac{3}{4}$	$\pm 2$
6	$\pm 3$
$7\frac{3}{4}$	$\pm 4$
10	$\pm 5$
$12\frac{3}{4}$	$\pm 6$
etc.	etc.

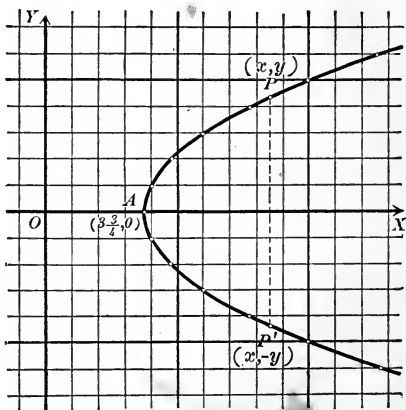

Second step. Assume values for  $y$  and compute  $x$ .

Since  $y^2$  only appears in the equation, positive and negative values of  $y$  give the same value of  $x$ . The calculation gives the table on p. 62.

For example, if  $y = \pm 3$ ,  
then  $x = \frac{1}{4}(9 + 15) = 6$ , etc.

Third step. Plot the points of the table.

Fourth step. Draw a smooth curve through these points.

*Discussion.* 1. From (7) it is evident that  $x$  increases as  $y$  increases. Hence the curve extends out indefinitely far from both axes.

2. Since (6) contains no odd powers of  $y$ , the equation may be written in the form

$$(-y)^2 - 4(x) + 15 = 0$$

by replacing  $(x, y)$  by  $(x, -y)$ . Hence the locus is symmetrical with respect to the axis of  $x$ .

The curve is called a parabola.

**Ex. 3.** Plot the locus of the equation

$$(8) \quad xy - 2y - 4 = 0.$$

*Solution.* First step. Solving for  $y$ ,

$$(9) \quad y = \frac{4}{x-2}.$$

Second step. Compute  $y$ , assuming values for  $x$ .

$x$	$y$	$x$	$y$
0	-2	0	-2
1	-4	-1	$-\frac{4}{3}$
$1\frac{1}{2}$	-8	-2	-1
$1\frac{3}{4}$	-16	-4	$-\frac{2}{3}$
2	$\infty$	-5	$-\frac{4}{7}$
$2\frac{1}{4}$	16	:	:
$2\frac{1}{2}$	8	-10	$-\frac{1}{3}$
3	4	etc.	etc.
4	2		
5	$\frac{4}{3}$		
6	1		
:			
12	0.4		
etc.	etc.		

When  $x = 2, y = \frac{4}{0} = \infty$ .

In such cases we assume values differing slightly from 2, both less and greater, as in the table.

Third step. Plot the points.

Fourth step. Draw the curve as in the figure in this case, the curve having two branches.

1. From (9) it appears that  $y$  diminishes and approaches zero as  $x$  increases indefinitely. The curve therefore extends indefinitely far to the right and left, approaching constantly the axis of  $x$ . If we solve (8) for  $x$  and write the result in the form

$$x = 2 + \frac{4}{y},$$

it is evident that  $x$  approaches 2 as  $y$  increases indefinitely. Hence the locus extends both

upward and downward indefinitely far, approaching in each case the line  $x = 2$ .

2. The equation cannot be transformed by any one of the three substitutions

$$(x, y) \text{ into } (x, -y),$$

$$(x, y) \text{ into } (-x, y),$$

$$(x, y) \text{ into } (-x, -y),$$

without altering it in such a way that the new equation will not have the same locus. The locus is therefore not symmetrical with respect to either axis, nor with respect to the origin.

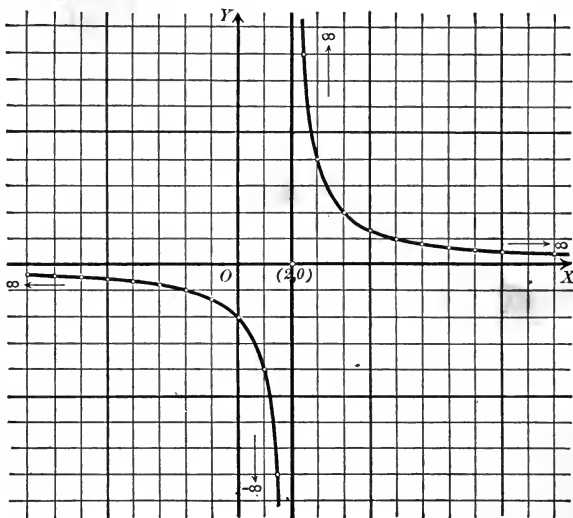

This curve is called an hyperbola.

Ex. 4. Draw the locus of the equation

$$(10) \quad 4y = x^3.$$

$x$	$y$	$x$	$y$
0	0	0	0
1	$\frac{1}{4}$	-1	$-\frac{1}{4}$
$1\frac{1}{2}$	$\frac{27}{32}$	$-1\frac{1}{2}$	$-\frac{27}{32}$
2	2	-2	-2
$2\frac{1}{2}$	$3\frac{29}{32}$	$-2\frac{1}{2}$	$-3\frac{29}{32}$
3	$6\frac{3}{4}$	-3	$-6\frac{3}{4}$
$3\frac{1}{2}$	$10\frac{23}{32}$	$-3\frac{1}{2}$	$-10\frac{23}{32}$

*Solution.* First step. Solving for  $y$ ,  

$$y = \frac{1}{4}x^3.$$

Second step. Assume values for  $x$  and compute  $y$ . Values of  $x$  must be taken between the integers in order to give points not too far apart.

For example, if

$$x = 2\frac{1}{2},$$

$$y = \frac{1}{4} \cdot \frac{125}{8} = \frac{125}{32} = 3\frac{29}{32}, \text{ etc.}$$

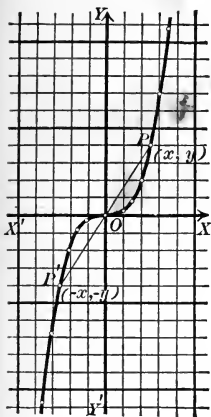

Third step. Plot the points thus found.

Fourth step. The points determine the curve of the figure.

*Discussion.* 1. From the given equation (10),  $x$  and  $y$  increase simultaneously, and therefore the curve extends out indefinitely from both axes.

2. In (10) there are no even powers nor constant term, so that by changing signs the equation may be written in the form

$$4(-y) = (-x)^3,$$

replacing  $(x, y)$  by  $(-x, -y)$ .

Hence *the locus is symmetrical with respect to the origin.*

The locus is called a *cubical parabola*.

**32. Symmetry.** In the above examples we have assumed the definition :

If the points of a curve can be arranged in pairs which are symmetrical with respect to an axis or a point, then the curve itself is said to be **symmetrical** with respect to that axis or point.

The method used for testing an equation for symmetry of the locus was as follows: if  $(x, y)$  can be replaced by  $(x, -y)$  throughout the equation without affecting the locus, then if  $(a, b)$  is on the locus,  $(a, -b)$  is also on the locus, and the points of the latter occur in pairs symmetrical with respect to  $XX'$ , etc. Hence

**Theorem IV.** *If the locus of an equation is unaffected by replacing  $y$  by  $-y$  throughout its equation, the locus is symmetrical with respect to the axis of  $x$ .*

*If the locus is unaffected by changing  $x$  to  $-x$  throughout its equation, the locus is symmetrical with respect to the axis of  $y$ .*

*If the locus is unaffected by changing both  $x$  and  $y$  to  $-x$  and  $-y$  throughout its equation, the locus is symmetrical with respect to the origin.*

These theorems may be made to assume a somewhat different form if the equation is *algebraic* in  $x$  and  $y$  (p. 10). The locus of an algebraic equation in the variables  $x$  and  $y$  is called an **algebraic curve**. Then from Theorem IV follows

**Theorem V. Symmetry of an algebraic curve.** *If no odd powers of  $y$  occur in an equation, the locus is symmetrical with respect to  $XX'$ ; if no odd powers of  $x$  occur, the locus is symmetrical with respect to  $YY'$ . If every term is of even\* degree, or every term of odd degree, the locus is symmetrical with respect to the origin.*

**33. Further discussion.** In this section we treat of three more questions which enter into the discussion of an equation.

3. Is the origin on the curve?

This question is settled by

**Theorem VI.** *The locus of an algebraic equation passes through the origin when there is no constant term in the equation.*

*Proof.* The coördinates  $(0, 0)$  satisfy the equation when there is no constant term. Hence the origin lies on the curve (Corollary, p. 46). Q. E. D.

4. What values of  $x$  and  $y$  are to be excluded?

Since coördinates are real numbers we have the

**Rule to determine all values of  $x$  and  $y$  which must be excluded.**

*First step.* Solve the equation for  $x$  in terms of  $y$ , and from this result determine all values of  $y$  for which the computed value of  $x$  will be imaginary. These values of  $y$  must be excluded.

*Second step.* Solve the equation for  $y$  in terms of  $x$ , and from this result determine all values of  $x$  for which the computed value of  $y$  will be imaginary. These values of  $x$  must be excluded.

The **intercepts** of a curve on the axis of  $x$  are the abscissas of the points of intersection of the curve and  $XX'$ .

The intercepts of a curve on the axis of  $y$  are the ordinates of the points of intersection of the curve and  $YY'$ .

**Rule to find the intercepts.**

*Substitute  $y = 0$  and solve for real values of  $x$ . This gives the intercepts on the axis of  $x$ .*

*Substitute  $x = 0$  and solve for real values of  $y$ . This gives the intercepts on the axis of  $y$ .*

\* The constant term must be regarded as of even (zero) degree.

The proof of the rule follows at once from the definitions. The rule just given explains how to answer the question:

5. What are the intercepts of the locus?

**34. Directions for discussing an equation.** Given an equation, the following questions should be answered in order before plotting the locus.

1. *Is the origin on the locus? (Theorem VI).*
2. *Is the locus symmetrical with respect to the axes or the origin? (Theorems IV and V).*
3. *What are the intercepts? (Rule, p. 66).*
4. *What values of  $x$  and  $y$  must be excluded? (Rule, p. 66).*
5. *Is the curve closed or does it pass off indefinitely far? (§ 31, p. 61).*

Answering these questions constitutes what is called a **general discussion** of the given equation.

**Ex. 1.** Give a general discussion of the equation

$$(1) \quad x^2 - 4y^2 + 16y = 0.$$

Draw the locus.

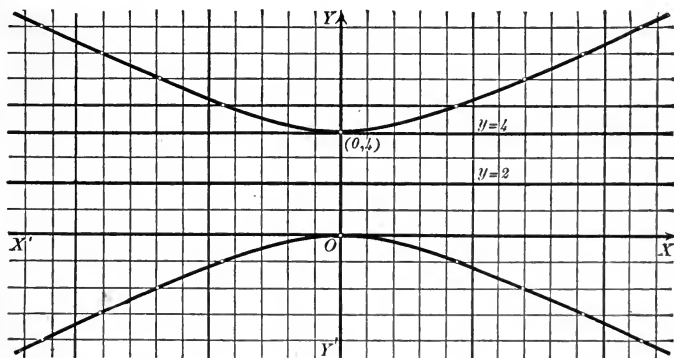

1. Since the equation contains no constant term, the origin is on the curve.
2. The equation contains no odd powers of  $x$ ; hence the locus is symmetrical with respect to  $YY'$ .
3. Putting  $y = 0$ , we find  $x = 0$ , the intercept on the axis of  $x$ . Putting  $x = 0$ , we find  $y = 0$  and  $4$ , the intercepts on the axis of  $y$ .
4. Solving for  $x$ ,

$$(2) \quad x = \pm 2\sqrt{y^2 - 4y}.$$

Hence all values of  $y$  between 0 and 4 must be excluded, since for such a value  $y^2 - 4y$  is negative.

Solving for  $y$ ,

$$(3) \quad y = 2 \pm \frac{1}{2} \sqrt{x^2 + 16}.$$

Hence no value of  $x$  is excluded, since  $x^2 + 16$  is always positive.

5. From (3),  $y$  increases as  $x$  increases, and the curve extends out indefinitely far from both axes.

Plotting the locus, using (2), the curve is found to be as in the figure. The curve is an hyperbola.

### PROBLEMS

1. Give a general discussion of each of the following equations and draw the locus.

- |                            |                                  |
|----------------------------|----------------------------------|
| (a) $x^2 - 4y = 0.$        | (n) $9y^2 - x^3 = 0.$            |
| ↪ (b) $y^2 - 4x + 3 = 0.$  | (o) $9y^2 + x^3 = 0.$            |
| (c) $x^2 + 4y^2 - 16 = 0.$ | (p) $2xy + 3x - 4 = 0.$          |
| (d) $9x^2 + y^2 - 18 = 0.$ | (q) $x^2 - xy + 8 = 0.$          |
| (e) $x^2 - 4y^2 - 16 = 0.$ | (r) $x^2 + xy - 4 = 0.$          |
| (f) $x^2 - 4y^2 + 16 = 0.$ | (s) $x^2 + 2xy - 3y = 0.$        |
| (g) $x^2 - y^2 + 4 = 0.$   | (t) $2xy - y^3 + 4x = 0.$        |
| (h) $x^2 - y + x = 0.$     | (u) $3x^2 - y + x = 0.$          |
| ↪ (i) $xy - 4 = 0.$        | (v) $4y^2 - 2x - y = 0.$         |
| ↪ (j) $9y + x^3 = 0.$      | (w) $x^2 - y^2 + 6x = 0.$        |
| (k) $4x - y^3 = 0.$        | ↪ (x) $x^2 + 4y^2 + 8y = 0.$     |
| ↪ (l) $6x - y^4 = 0.$      | (y) $9x^2 + y^2 + 18x - 6y = 0.$ |
| (m) $5x - y + y^3 = 0.$    | (z) $9x^2 - y^2 + 18x + 6y = 0.$ |

2. Determine the general nature of the locus in each of the following equations by assuming *particular* values for the arbitrary constants, but not *special* values, that is, values which give the equation an added peculiarity.\*

- |  |                              |
|--|------------------------------|
| (a) $y^2 = 2mx.$                             | (f) $x^2 - y^2 = a^2.$       |
| (b) $x^2 - 2my = m^2.$                       | (g) $x^2 + y^2 = r^2.$       |
| (c) $\frac{x^2}{a^2} + \frac{y^2}{b^2} = 1.$ | (h) $x^2 + y^2 = 2rx.$       |
| (d) $2xy = a^2.$                             | (i) $x^2 + y^2 = 2ry.$       |
| (e) $\frac{x^2}{a^2} - \frac{y^2}{b^2} = 1.$ | (j) $x^2 + y^2 = 2ax + 2by.$ |
|  | (k) $ay^2 = x^3.$            |
|  | (l) $a^2y = x^3.$            |

\* For example, in (a) and (b)  $m = 0$  is a special value. In fact, in all these examples zero is a special value for any constant.



3. Draw the locus of the equation

$$y^2 = (x - a)(x - b)(x - c),$$

(a) when  $a < b < c$ .

(c) when  $a < b, b = c$ .

(b) when  $a = b < c$ .

(d) when  $a = b = c$ .

The loci of the equations (a) to (f) in problem 2 are all of the class known as *conics*, or *conic sections*, — curves following straight lines and circles in the matter of their simplicity.

A **conic section** is the locus of a point whose distances from a fixed point and a fixed line are in a constant ratio.

4. Show that every conic is represented by an equation of the second degree in  $x$  and  $y$ .

*Hint.* Take  $YY'$  to coincide with the fixed line, and draw  $XX'$  through the fixed point. Denote the fixed point by  $(p, 0)$  and the constant ratio by  $e$ .

$$\text{Ans. } (1 - e^2)x^2 + y^2 - 2px + p^2 = 0.$$

5. Discuss and plot the locus of the equation of problem 4,

(a) when  $e = 1$ . The conic is now called a *parabola* (see p. 63).

(b) when  $e < 1$ . The conic is now called an *ellipse* (see p. 62).

(c) when  $e > 1$ . The conic is now called an *hyperbola* (see p. 64).

6. Plot each of the following.

(a)  $x^2y - 5 = 0$ .

(e)  $y = \frac{5}{x^2 - 3x}$ .

(i)  $x = \frac{y^2}{y - 1}$ .

(b)  $x^2y - y + 2x = 0$ .

(f)  $y = \frac{4x^2}{x^2 - 4}$ .

(j)  $x = \frac{y - 2}{y - 3}$ .

(c)  $xy^2 - 4x + 6 = 0$ .

(g)  $y = \frac{x - 3}{x + 1}$ .

(k)  $4x = \frac{y^2}{y^2 - 9}$ .

(d)  $x^3y - y + 8 = 0$ .

(h)  $y = \frac{x^2 - 4}{x^2 + x}$ .

(l)  $x = \frac{8y}{3 - y^2}$ .

**35. Points of intersection.** If two curves whose equations are given intersect, the coördinates of each point of intersection must satisfy both equations when substituted in them for the variables (Corollary, p. 46). In Algebra it is shown that *all* values satisfying two equations in two unknowns may be found by regarding these equations as simultaneous in the unknowns and solving. Hence the

*Rule to find the points of intersection of two curves whose equations are given.*

*First step.* Consider the equations as simultaneous in the coördinates, and solve as in Algebra.

*Second step.* Arrange the real solutions in corresponding pairs. These will be the coördinates of all the points of intersection.

Notice that only *real* solutions correspond to common points of the two curves, since coördinates are always real numbers.

**Ex. 1.** Find the points of intersection of

$$(1) \quad x - 7y + 25 = 0,$$

$$(2) \quad x^2 + y^2 = 25.$$

*Solution.* First step. Solving

(1) for  $x$ ,

$$(3) \quad x = 7y - 25.$$

Substituting in (2),

$$(7y - 25)^2 + y^2 = 25.$$

Reducing,  $y^2 - 7y + 12 = 0$ .

$$\therefore y = 3 \text{ and } 4.$$

Substituting in (3) [not in (2)],

$$x = -4 \text{ and } +3.$$

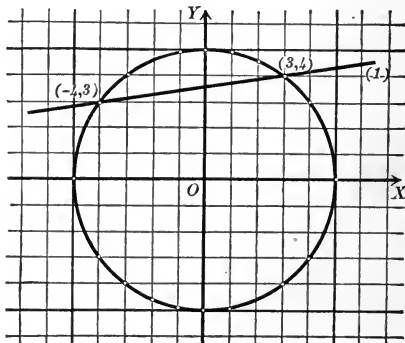

Second step. Arranging, the points of intersection are  $(-4, 3)$  and  $(3, 4)$ . *Ans.*

In the figure the straight line (1) is the locus of equation (1), and the circle the locus of (2).

**Ex. 2.** Find the points of intersection of the loci of

$$(4) \quad 2x^2 + 3y^2 = 35,$$

$$(5) \quad 3x^2 - 4y = 0.$$

*Solution.* First step. Solving (5) for  $x^2$ ,

$$(6) \quad x^2 = \frac{4}{3}y.$$

Substituting in (4) and reducing,

$$9y^2 + 8y - 105 = 0.$$

$$\therefore y = 3 \text{ and } -\frac{35}{9}.$$

Substituting in (6) and solving,

$$x = \pm 2 \text{ and } \pm \frac{1}{3}\sqrt{-210}.$$

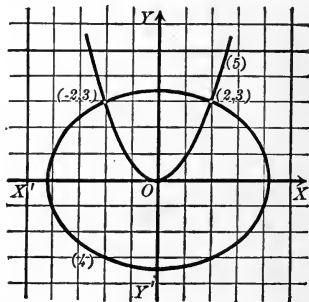

Second step. Arranging the *real* values, we find the points of intersection are  $(+2, 3)$ ,  $(-2, 3)$ . *Ans.*

In the figure the ellipse (4) is the locus of (4), and the parabola (5) the locus of (5).

## PROBLEMS

Find the points of intersection of the following loci.

1.  $\left. \begin{aligned} 7x - 11y + 1 &= 0 \\ x + y - 2 &= 0 \end{aligned} \right\}$ . *Ans.*  $(\frac{7}{5}, \frac{5}{5})$ .
2.  $\left. \begin{aligned} x + y &= 7 \\ x - y &= 5 \end{aligned} \right\}$ . *Ans.* (6, 1).
3.  $\left. \begin{aligned} y &= 3x + 2 \\ x^2 + y^2 &= 4 \end{aligned} \right\}$ . *Ans.* (0, 2),  $(-\frac{6}{5}, -\frac{8}{5})$ .
4.  $\left. \begin{aligned} y^2 &= 16x \\ y - x &= 0 \end{aligned} \right\}$ . *Ans.* (0, 0), (16, 16).
5.  $\left. \begin{aligned} x^2 + y^2 &= a^2 \\ 3x + y + a &= 0 \end{aligned} \right\}$ . *Ans.* (0, -a),  $(-\frac{3a}{5}, \frac{4a}{5})$ .
6.  $\left. \begin{aligned} x^2 + y^2 - 4x + 6y - 12 &= 0 \\ 2y &= 3x + 3 \end{aligned} \right\}$ . *Ans.*  $(\frac{1}{13}, \frac{2}{13})$ , (-3, -3).
7.  $\left. \begin{aligned} x^2 - y^2 &= 16 \\ x^2 &= 8y \end{aligned} \right\}$ . *Ans.*  $(\pm 4\sqrt{2}, 4)$ .
8.  $\left. \begin{aligned} x^2 + y^2 &= 41 \\ xy &= 20 \end{aligned} \right\}$ . *Ans.*  $(\pm 5, \pm 4)$ ,  $(\pm 4, \pm 5)$ .
9.  $\left. \begin{aligned} x^2 + y^2 - 6x - 2y - 15 &= 0 \\ 9x^2 + 9y^2 + 6x - 6y - 27 &= 0 \end{aligned} \right\}$ . *Ans.* (-2, 1),  $(-\frac{2}{13}, -\frac{12}{13})$ .
10.  $\left. \begin{aligned} x^2 + y^2 &= 49 \\ y &= 3x + b \end{aligned} \right\}$ . For what values of  $b$  are the curves tangent?  
*Ans.*  $(\frac{-3b \pm \sqrt{490 - b^2}}{10}, \frac{b \pm 3\sqrt{490 - b^2}}{10})$ ,  $b = \pm 7\sqrt{10}$ .
11.  $\left. \begin{aligned} y^2 &= 2px \\ x^2 &= 2py \end{aligned} \right\}$ . *Ans.* (0, 0), (2p, 2p).
12.  $\left. \begin{aligned} 4x^2 + y^2 &= 5 \\ y^2 &= 8x \end{aligned} \right\}$ . *Ans.*  $(\frac{1}{2}, 2)$ ,  $(\frac{1}{2}, -2)$ .
13.  $\left. \begin{aligned} x^2 &= 4ay \\ y &= \frac{8a^3}{x^2 + 4a^2} \end{aligned} \right\}$ . *Ans.* (2a, a), (-2a, a).
14.  $\left. \begin{aligned} x^2 + y^2 &= 100 \\ y^2 &= \frac{9x}{2} \end{aligned} \right\}$ . *Ans.* (8, 6), (8, -6).
15.  $\left. \begin{aligned} x^2 + y^2 &= 5a^2 \\ x^2 &= 4ay \end{aligned} \right\}$ . *Ans.* (2a, a), (-2a, a).
16.  $\left. \begin{aligned} b^2x^2 + a^2y^2 &= a^2b^2 \\ x^2 + y^2 &= a^2 \end{aligned} \right\}$ . *Ans.* (a, 0), (-a, 0).

17. The two loci  $\frac{x^2}{4} - \frac{y^2}{9} = 1$  and  $\frac{x^2}{4} + \frac{y^2}{9} = 4$  intersect in four points. Find the lengths of the sides and of the diagonals of the quadrilateral formed by these points.

*Ans.* Points,  $(\pm\sqrt{10}, \pm\frac{3}{2}\sqrt{6})$ . Sides,  $2\sqrt{10}, 3\sqrt{6}$ . Diagonals,  $\sqrt{94}$ .

Find the area of the triangles and polygons whose sides are the loci of the following equations.

18.  $3x + y + 4 = 0, 3x - 5y + 34 = 0, 3x - 2y + 1 = 0$ . *Ans.* 36.

19.  $x + 2y = 5, 2x + y = 7, y = x + 1$ . *Ans.*  $\frac{3}{2}$ .

20.  $x + y = a, x - 2y = 4a, y - x + 7a = 0$ . *Ans.*  $12a^2$ .

21.  $x = 0, y = 0, x = 4, y = -6$ . *Ans.* 24.

22.  $x - y = 0, x + y = 0, x - y = a, x + y = b$ . *Ans.*  $\frac{ab}{2}$ .

23.  $y = 3x - 9, y = 3x + 5, 2y = x - 6, 2y = x + 14$ . *Ans.* 56.

24. Find the distance between the points of intersection of the curves  $3x - 2y + 6 = 0, x^2 + y^2 = 9$ . *Ans.*  $\frac{1}{3}\sqrt{13}$ .

25. Does the locus of  $y^2 = 4x$  intersect the locus of  $2x + 3y + 2 = 0$ ? *Ans.* Yes.

26. For what value of  $a$  will the three lines  $3x + y - 2 = 0, ax + 2y - 3 = 0, 2x - y - 3 = 0$  meet in a point? *Ans.*  $a = 5$ .

27. Find the length of the common chord of  $x^2 + y^2 = 13$  and  $y^2 = 3x + 3$ . *Ans.* 6.

28. If the equations of the sides of a triangle are  $x + 7y + 11 = 0, 3x + y - 7 = 0, x - 3y + 1 = 0$ , find the length of each of the medians. *Ans.*  $2\sqrt{5}, \frac{5}{2}\sqrt{2}, \frac{1}{2}\sqrt{170}$ .

Show that the following loci intersect in two coincident points, that is, are tangent to each other.

29.  $y^2 - 10x - 6y - 31 = 0, 2y - 10x = 47$ .

30.  $9x^2 - 4y^2 + 54x - 16y + 29 = 0, 15x - 8y + 11 = 0$ .

36. **Transcendental curves.** The equations thus far considered have been *algebraic* in  $x$  and  $y$ , since powers alone of the variables have appeared. We shall now see how to plot certain so-called *transcendental curves*, in which the variables appear otherwise than in powers. The Rule, p. 53, will be followed.

Ex. 1. Draw the locus of

(1)  $y = \log_{10} x.$

*Solution.* Assuming values for  $x$ ,  $y$  may be computed by a table of logarithms, or, remembering the definition of a logarithm, from (1) will follow

(2)  $x = 10^y.$

Hence values may also be assumed for  $y$ , and  $x$  computed by (2). This is done in the table.

$x$	$y$	$x$	$y$
1	0	.1	-1
3.1	$\frac{1}{2}$	.01	-2
10	1	.001	-3
100	2	.0001	-4
etc.	etc.	etc.	etc.

In plotting,

unit length on  $XX'$  is 2 divisions,  
unit length on  $YY'$  is 4 divisions.

*General discussion.* 1. The curve does not pass through the origin, since  $(0, 0)$  does not satisfy the equation.

2. The curve is not symmetrical with respect to either axis or the origin.

3. In (1), putting  $x = 0$ ,

$$y = \log 0 = -\infty = \text{intercept on } YY'.$$

In (2), putting  $y = 0$ ,

$$x = 10^0 = 1 = \text{intercept on } XX'.$$

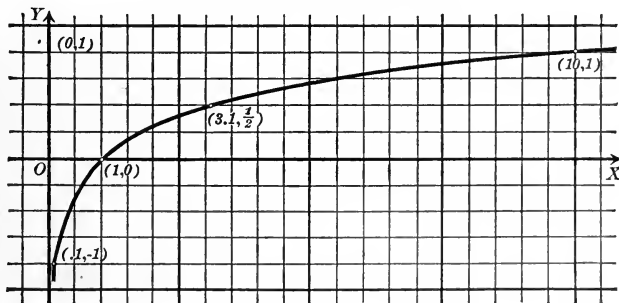

4. From (2), since logarithms of negative numbers do not exist, *all negative values of  $x$  are excluded.*

From (2) no value of  $y$  is excluded.

5. From (2), as  $y$  increases  $x$  increases, and the locus extends out indefinitely from both axes.

From (1), as

$x$  approaches zero,  
 $y$  approaches negative infinity;

so we see that the curve extends down indefinitely and approaches nearer and nearer to  $YY'$ .

Ex. 2. Draw the locus of

$$(3) \quad y = \sin x$$

if the abscissa  $x$  is the *circular measure* of an angle (Chapter I, p. 12).

*Solution.* Assuming values for  $x$  and finding the corresponding number of degrees, we may compute  $y$  by the table of Natural Sines, p. 14.

For example, if

$$x = 1, \text{ since } 1 \text{ radian} = 57^\circ.29,$$

$$y = \sin 57^\circ.29 = .843.$$

[by (3)]

It will be more convenient for plotting to choose for  $x$  such values that the corresponding number of degrees is a whole number. Hence  $x$  is expressed in terms of  $\pi$  in the table.

For example, if

$$x = \frac{\pi}{3}, \quad y = \sin \frac{\pi}{3} = \sin 60^\circ = .86.$$

$$x = -\frac{2\pi}{3}, \quad y = \sin -\frac{2\pi}{3} = -\sin \frac{2\pi}{3} \quad (4, \text{ p. } 12)$$

$$= -\sin 120^\circ = -\sin 60^\circ \quad (5, \text{ p. } 13)$$

$$= -.86.$$

In plotting, three divisions being taken as the unit of length, lay off

$$AO = OB = \pi = 3.1416,$$

and divide  $AO$  and  $OB$  up into *six* equal parts.

The course of the curve beyond  $B$  is easily determined from the relation

$$\sin(2\pi + x) = \sin x.$$

$$\text{Hence } y = \sin x = \sin(2\pi + x),$$

that is, the curve is *unchanged* if  $x + 2\pi$  be substituted for  $x$ . This means, however, that every point is moved a distance  $2\pi$  to the right. Hence the arc

$x$	$y$	$x$	$y$
0	0	0	0
$\frac{\pi}{6}$	.50	$-\frac{\pi}{6}$	-.50
$\frac{\pi}{3}$	.86	$-\frac{\pi}{3}$	-.86
$\frac{\pi}{2}$	1.00	$-\frac{\pi}{2}$	-1.00
$\frac{2\pi}{3}$	.86	$-\frac{2\pi}{3}$	-.86
$\frac{5\pi}{6}$	.50	$-\frac{5\pi}{6}$	-.50
$\pi$	0	$-\pi$	0

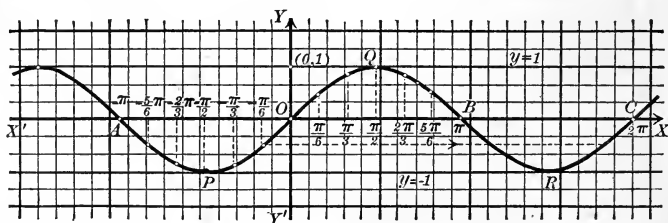

$APO$  may be moved parallel to  $XX'$  until  $A$  falls on  $B$ , that is, into the position  $BRC$ , and it will also be a part of the curve in its new position.

Also, the arc  $OQB$  may be displaced parallel to  $XX'$  until  $O$  falls upon  $C$ . In this way it is seen that the entire locus consists of an indefinite number of congruent arcs, alternately above and below  $XX'$ .

*General discussion.* 1. The curve passes through the origin, since  $(0, 0)$  satisfies the equation.

2. Since  $\sin(-x) = -\sin x$ , changing signs in (3),

$$-y = -\sin x,$$

or

$$-y = \sin(-x).$$

Hence the locus is unchanged if  $(x, y)$  is replaced by  $(-x, -y)$ , and the curve is *symmetrical with respect to the origin* (Theorem IV, p. 65).

3. In (3), if

$$x = 0,$$

$$y = \sin 0 = 0 = \text{intercept on the axis of } y.$$

Solving (3) for  $x$ ,

(4)

$$x = \sin^{-1} y.$$

In (4), if

$$y = 0,$$

$$x = \sin^{-1} 0$$

$$= n\pi, n \text{ being any integer.}$$

Hence the curve cuts the axis of  $x$  an indefinite number of times both on the right and left of  $O$ , these points being at a distance of  $\pi$  from one another.

4. In (3),  $x$  may have any value, since any number is the circular measure of an angle.

In (4),  $y$  may have values from  $-1$  to  $+1$  inclusive, since the sine of an angle has values only from  $-1$  to  $+1$  inclusive.

5. The curve extends out indefinitely along  $XX'$  in both directions, but is contained entirely between the lines  $y = +1$ ,  $y = -1$ .

The locus is called the *wave curve*, from its shape, or the *sinusoid*, from its equation (3).

### PROBLEMS

Plot the loci of the following equations.

1.  $y = \cos x.$

7.  $y = 2 \log_{10} x.$

2.  $y = \tan x.$

8.  $y = (1 + x)^{\frac{1}{x}}.$

3.  $y = \sec x.$

9.  $y = \sin 2x.$

4.  $y = \sin^{-1} x.$

10.  $y = \tan \frac{x}{2}.$

5.  $y = \tan^{-1} x.$

11.  $y = 2 \cos x.$

6.  $y = 2^x.$

12.  $y = \sin x + \cos x$

## CHAPTER IV

### THE STRAIGHT LINE AND THE GENERAL EQUATION OF THE FIRST DEGREE

**37.** The idea of coördinates and the intimate relation connecting a curve and an equation, which results from the introduction of coördinates into the study of Geometry, have been considered in the preceding chapters. Analytic Geometry has to do largely with a more detailed study of particular curves and equations. In this chapter we shall consider in detail the straight line and the general equation of the first degree in the variables  $x$  and  $y$  representing coördinates.

**38.** The degree of the equation of a straight line. It was shown in Chapter III (Theorem I, p. 51) that

$$(1) \qquad y = mx + b$$

is the equation of the straight line whose slope is  $m$  and whose intercept on the  $Y$ -axis is  $b$ ;  $m$  and  $b$  may have any values, positive, negative, or zero (p. 27). But if a line is parallel to the  $Y$ -axis, its equation may not be put in the form (1); for, in the first place, the line has no intercept on the  $Y$ -axis, and, in the second place, its slope is infinite and hence cannot be substituted for  $m$  in (1). The equation of a line parallel to the  $Y$ -axis is, however, of the form

$$(2) \qquad x = \text{constant.}$$

The equation of any line may be put either in the form (1) or (2). As these equations are both of the first degree in  $x$  and  $y$  we have

**Theorem I.** *The equation of any straight line is of the first degree in the coördinates  $x$  and  $y$ .*



39. The general equation of the first degree,  $Ax + By + C = 0$ .  
The equation

$$(1) \quad Ax + By + C = 0,$$

where  $A$ ,  $B$ , and  $C$  are arbitrary constants (p. 1), is called the **general equation of the first degree** in  $x$  and  $y$  because every equation of the first degree may be reduced to that form.

Equation (1) represents all straight lines.

For the equation  $y = mx + b$  may be written  $mx - y + b = 0$ , which is of the form (1) if  $A = m$ ,  $B = -1$ ,  $C = b$ ; and the equation  $x = \text{constant}$  may be written  $x - \text{constant} = 0$ , which is of the form (1) if  $A = 1$ ,  $B = 0$ ,  $C = -\text{constant}$ .

**Theorem II.** (Converse of Theorem I.) *The locus of the general equation of the first degree*

$$Ax + By + C = 0$$

*is a straight line.*

*Proof.* Solving (1) for  $y$ , we obtain

$$(2) \quad y = -\frac{A}{B}x - \frac{C}{B}.$$

This equation has the same locus as (1) (Theorem III, p. 52).

By Theorem I, p. 51, the locus of (2) is the straight line whose slope is  $m = -\frac{A}{B}$  and whose intercept on the  $Y$ -axis is  $b = -\frac{C}{B}$ .

If, however,  $B = 0$ , it is impossible to write (1) in the form (2). But if  $B = 0$ , (1) becomes

$$Ax + C = 0,$$

or

$$\left[ x = -\frac{C}{A} \right]$$

The locus of this equation is a straight line parallel to the  $Y$ -axis (1, p. 50). Hence in all cases the locus of (1) is a straight line.

Q. E. D.

**Corollary I.** *The slope of the line*

$$Ax + By + C = 0$$

*is  $m = -\frac{A}{B}$ ; that is, the coefficient of  $x$  with its sign changed divided by the coefficient of  $y$ .*

**Corollary II.** *The lines*

$$Ax + By + C = 0$$

and

$$A'x + B'y + C' = 0$$

are parallel when and only when the coefficients of  $x$  and  $y$  are proportional; that is,

$$\frac{A}{A'} = \frac{B}{B'}.$$

For two lines are parallel when and only when their slopes are equal (Theorem VI, p. 29); that is, when and only when

$$-\frac{A}{B} = -\frac{A'}{B'}.$$

Changing the signs and applying alternation, we obtain

$$\frac{A}{A'} = \frac{B}{B'}.$$

**Corollary III.** *The lines*

$$Ax + By + C = 0$$

and

$$A'x + B'y + C' = 0$$

are perpendicular when and only when

$$AA' + BB' = 0.$$

For two lines are perpendicular when and only when the slope of one is the negative reciprocal of the slope of the second (Theorem VI, p. 29); that is,

$$-\frac{A}{B} = \frac{B'}{A'},$$

or

$$AA' + BB' = 0.$$

**Corollary IV.** *The intercepts of the line*

$$Ax + By + C = 0$$

on the  $X$ - and  $Y$ -axes are respectively

$$a = -\frac{C}{A} \text{ and } b = -\frac{C}{B}.$$

For the intercept on the  $X$ -axis is found (p. 66) by setting  $y = 0$  and solving for  $x$ , and the intercept on the  $Y$ -axis has been found in the above proof.

Corollaries I and IV are given chiefly for purposes of reference. In a numerical example the intercepts are found most simply by applying the general rule already given (p. 66); and the slope is found by reducing the equation to the form

$$y = mx + b,$$

when the coefficient of  $x$  will be the slope.

Theorems I and II may be stated together as follows :

*The locus of an equation is a straight line when and only when the equation is of the first degree in  $x$  and  $y$ .*

Theorem II asserts that the locus of every equation of the first degree is a straight line. Then, to plot the locus of an equation of the first degree it is merely necessary to plot two points on the locus and draw the straight line passing through them. The two simplest points to plot are those at which the line crosses the axes. But if those points are very near the origin it is better to use but one of them and some other point not near the origin whose coördinates are found by the Rule on p. 53.

**Theorem III.** *When two equations of the first degree,*

$$(3) \quad Ax + By + C = 0$$

and

$$(4) \quad A'x + B'y + C' = 0,$$

*have the same locus, then the corresponding coefficients are proportional; that is,*

$$\frac{A}{A'} = \frac{B}{B'} = \frac{C}{C'}.$$

*Proof.* The lines whose equations are (3) and (4) are by hypothesis identical and hence they have the same slope and the same intercept on the  $Y$ -axis. Since they have the same slope,

$$\frac{A}{B} = \frac{A'}{B'}, \quad (\text{Corollary I, p. 77})$$

and since they have the same intercept on the  $Y$ -axis,

$$\frac{C}{B} = \frac{C'}{B'}, \quad (\text{Corollary IV, p. 78})$$

by alternation we obtain

$$\frac{A}{A'} = \frac{B}{B'} \text{ and } \frac{C}{C'} = \frac{B}{B'};$$

and hence

$$\frac{A}{A'} = \frac{B}{B'} = \frac{C}{C'}.$$

**Ex. 1.** Find the values of  $a$  and  $b$  for which the equations

$$2ax + 2y - 5 = 0$$

and

$$4x - 3y + 7b = 0$$

will represent the same straight line.

*Solution.* These two equations will represent the same straight line if (Theorem III)

$$\frac{2a}{4} = \frac{2}{-3} = \frac{-5}{7b};$$

and hence the required values are obtained by solving

$$\frac{2a}{4} = \frac{2}{-3} \text{ and } \frac{2}{-3} = \frac{-5}{7b}$$

for  $a$  and  $b$ . This gives

$$a = -\frac{3}{2}, \quad b = \frac{15}{14}.$$

**40. Geometric interpretation of the solution of two equations of the first degree.** If we solve the equations

$$(1) \quad Ax + By + C = 0$$

and

$$(2) \quad A'x + B'y + C' = 0,$$

we obtain the coördinates of the points of intersection of the lines whose equations are (1) and (2) (Rule, p. 69). But if these lines are parallel they do not intersect, and if they are identical they intersect in all of their points. The relation between the *position* of the lines whose equations are (1) and (2) and the *number of solutions* of the simultaneous equations (1) and (2) may be indicated as follows:

<i>Position of lines</i>	<i>Number of solutions of equations</i>
Intersecting lines.	One solution.
Parallel lines.	No solution.
Coincident lines.	An infinite number.

It is sometimes as convenient to be able to determine the *number* of solutions of two equations of the first degree without solving them as it is to be able to determine the *nature* of the roots of a quadratic equation without solving it. The following theorem enables us to do this.

**Theorem IV.** *Two equations of the first degree,*

$$Ax + By + C = 0$$

and

$$A'x + B'y + C' = 0,$$

have, in general, one solution for  $x$  and  $y$ ; but if

$$\frac{A}{A'} = \frac{B}{B'},$$

there is no solution unless

$$\frac{A}{A'} = \frac{B}{B'} = \frac{C}{C'},$$

when there is an infinite number of solutions.

The proof follows at once from Corollary II, p. 78, and Theorem III.

#### PROBLEMS

1. Find the intercepts of the following lines and plot the lines.

(a)  $2x + 3y = 6.$  Ans. 3, 2.

(b)  $\frac{x}{2} + \frac{y}{4} = 1.$   $2x + y = 4$  Ans. 2, 4.

(c)  $\frac{x}{3} - \frac{y}{5} = 1.$   $2 \quad y$  Ans. 3, -5.

(d)  $\frac{x}{4} + \frac{y}{-2} = 1.$  Ans. 4, -2.

2. Plot the following lines.

(a)  $2x - 3y + 5 = 0.$  (c)  $\frac{x}{2} + \frac{y}{3} = 1.$

(b)  $y - 5 - 4x = 0.$  (d)  $\frac{x}{3} - \frac{y}{4} = 1.$

3. Find the equations, and reduce them to the general form, of the lines for which

(a)  $m = 2, b = -3.$  Ans.  $2x - y - 3 = 0.$

(b)  $m = -\frac{1}{2}, b = \frac{3}{2}.$  Ans.  $x + 2y - 3 = 0.$

(c)  $m = \frac{2}{3}, b = -\frac{5}{2}.$  Ans.  $4x - 10y - 25 = 0.$

(d)  $\alpha = \frac{\pi}{4}, b = -2.$  Ans.  $x - y - 2 = 0.$

(e)  $\alpha = \frac{3\pi}{4}, b = 3.$  Ans.  $x + y - 3 = 0.$

*Hint.* Substitute in  $y = mx + b.$

4. Find the number of solutions of the following pairs of equations and plot the loci of the equations.

(a)  $\begin{cases} 2x + 3y - 6 = 0. \\ 4x + 6y + 9 = 0. \end{cases}$  *Ans.* No solution.

(b)  $\begin{cases} x - y = 1. \\ x + y = 1. \end{cases}$  *Ans.* One.

(c)  $\begin{cases} 2 - 3x = y. \\ 6x + 2y = 4. \end{cases}$  *Ans.* An infinite number.

(d)  $\begin{cases} 4x - 5y + 20 = 0. \\ 12x - 15y + 6 = 0. \end{cases}$  *Ans.* No solution.

5. Plot the lines  $2x - 3y + 6 = 0$  and  $x - y = 0$ . Also plot the locus of  $(2x - 3y + 6) + k(x - y) = 0$  for  $k = 0, \pm 1, \pm 2$ .

6. Select pairs of parallel and perpendicular lines from the following.

(a)  $\begin{cases} L_1: y = 2x - 3. \\ L_2: y = -3x + 2. \\ L_3: y = 2x + 7. \\ L_4: y = \frac{1}{3}x + 4. \end{cases}$  *Ans.*  $L_1 \parallel L_3$ ;  $L_2 \perp L_4$ .  
*Handwritten:*  $m_2 = -\frac{1}{m_1}$  }  $\perp$

(b)  $\begin{cases} L_1: x + 3y = 0. \\ L_2: 8x + y + 1 = 0. \\ L_3: 9x - 3y + 2 = 0. \end{cases}$  *Ans.*  $L_1 \perp L_3$ .

(c)  $\begin{cases} L_1: 2x - 5y = 8. \\ L_2: 5y + 2x = 8. \\ L_3: 35x - 14y = 8. \end{cases}$  *Ans.*  $L_2 \perp L_3$ .

7. Show that the quadrilateral whose sides are  $2x - 3y + 4 = 0$ ,  $3x - y - 2 = 0$ ,  $4x - 6y - 9 = 0$ , and  $6x - 2y + 4 = 0$  is a parallelogram.

8. Find the equation of the line whose slope is  $-2$  which passes through the point of intersection of  $y = 3x + 4$  and  $y = -x + 4$ .

*Ans.*  $2x + y - 4 = 0$ .

9. What is the locus of  $y = mx + b$  if  $b$  is constant and  $m$  arbitrary? if  $m$  is constant and  $b$  arbitrary?

10. Write an equation which will represent all lines parallel to the line

(a)  $y = 2x + 7$ . (c)  $y - 3x - 4 = 0$ .

(b)  $y = -x + 9$ . (d)  $2y - 4x + 3 = 0$ .

11. Write an equation which will represent all lines having the same intercept on the  $Y$ -axis as (a), (b), (c), and (d) in problem 10.

12. Find the equation of the line parallel to  $2x - 3y = 0$  whose intercept on the  $Y$ -axis is  $-2$ .

*Ans.*  $2x - 3y - 6 = 0$ .

13. What is the locus of  $Ax + By + C = 0$  if  $B$  and  $C$  are constant and  $A$  arbitrary? if  $A$  and  $B$  are constant and  $C$  arbitrary?

**41. Straight lines determined by two conditions.** In Elementary Geometry we have many illustrations of the determination of a straight line by two conditions. Thus two points determine a line, and through a given point one line, and only one, can be drawn parallel to a given line. Sometimes, however, there will be two or more lines satisfying the two conditions; thus through a given point outside of a circle we can draw two lines tangent to the circle, and four lines may be drawn tangent to two circles if they do not intersect.

Analytically such facts present themselves as follows. The equation of any straight line is of the form (Theorem II, p. 77)

$$(1) \quad Ax + By + C = 0,$$

and the line is completely determined if the values of two of the coefficients  $A$ ,  $B$ , and  $C$  are known in terms of the third.

For example, if  $A = 2B$  and  $C = -3B$ , equation (1) becomes

$$2Bx + By - 3B = 0,$$

or 
$$2x + y - 3 = 0.$$

Any geometrical condition which the line must satisfy gives rise to an equation between one or more of the coefficients  $A$ ,  $B$ , and  $C$ .

Thus if the line is to pass through the origin, we must have  $C = 0$  (Theorem VI, p. 66); or if the slope is to be 3, then  $-\frac{A}{B} = 3$  (Corollary I, p. 77).

Two conditions which the line must satisfy will then give rise to two equations in  $A$ ,  $B$ , and  $C$  from which the values of two of the coefficients may be determined in terms of the third, and the line is then determined.

If these equations are of the first degree, there will be only one line fulfilling the given conditions, for two equations of the first degree have, in general, only one solution (Theorem IV, p. 81). If one equation is a quadratic and the other of the first degree, then there will be two lines fulfilling the conditions, provided that the solutions of the equations are real. And, in general, the number of lines fulfilling the two given conditions will depend on the degrees of the equations in the  $A$ ,  $B$ , and  $C$  to which they give rise.

**Rule to determine the equation of a straight line which satisfies two conditions.**

*First step.* Assume that the equation of the line is

$$Ax + By + C = 0.$$

*Second step.* Find two equations between  $A$ ,  $B$ , and  $C$  each of which expresses algebraically the fact that the line satisfies one of the given conditions.

*Third step.* Solve these equations for two of the coefficients  $A$ ,  $B$ , and  $C$  in terms of the third.

*Fourth step.* Substitute the results of the third step in the equation in the first step and divide out the remaining coefficient. The result is the required equation.

**Ex. 1.** Find the equation of the line through the two points  $P_1(5, -1)$  and  $P_2(2, -2)$ .

*Solution.* First step. Let the required equation be

$$(1) \quad Ax + By + C = 0.$$

Second step. Since  $P_1$  lies on the locus of (1) (Corollary, p. 46),

$$(2) \quad 5A - B + C = 0;$$

and since  $P_2$  lies on the line,

$$(3) \quad 2A - 2B + C = 0.$$

Third step. Solving (2) and (3) for  $A$  and  $B$  in terms of  $C$ , we obtain

$$A = -\frac{1}{3}C, \quad B = \frac{2}{3}C.$$

Fourth step. Substituting in (1),

$$-\frac{1}{3}Cx + \frac{2}{3}Cy + C = 0.$$

Dividing by  $C$  and simplifying, the required equation is

$$x - 3y - 8 = 0.$$

**Ex. 2.** Find the equation of the line passing through  $P_1(3, -2)$  whose slope is  $-\frac{1}{4}$ .

*Solution.* First step. Let the required equation be

$$(4) \quad Ax + By + C = 0.$$

Second step. Since  $P_1$  lies on (4),

$$(5) \quad 3A - 2B + C = 0;$$

and since the slope is  $-\frac{1}{4}$ ,

$$(6) \quad -\frac{A}{B} = -\frac{1}{4}.$$

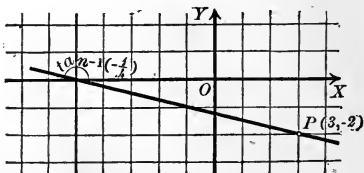
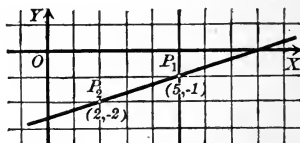



Third step. Solving (5) and (6) for  $A$  and  $C$  in terms of  $B$ , we obtain

$$A = \frac{1}{4}B, \quad C = \frac{5}{4}B.$$

Fourth step. Substituting in (4),

$$\frac{1}{4}Bx + By + \frac{5}{4}B = 0,$$

or 
$$x + 4y + 5 = 0.$$

*Slope formula*

$$m = \frac{y_2 - y_1}{x_2 - x_1}$$

$$-\frac{1}{4} = \frac{y+2}{x-3}$$

$$x + 4y + 5 = 0$$

### PROBLEMS

1. Find the equation of the line satisfying the following conditions and plot the lines.

- |  |  |
|--|--|
| (a) Passing through (0, 0) and (8, 2).                                       | <i>Ans.</i> $x - 4y = 0.$                    |
| (b) Passing through (-1, 1) and (-3, 1).                                     | <i>Ans.</i> $y - 1 = 0.$                     |
| (c) Passing through (-3, 1) and slope = 2.                                   | <i>Ans.</i> $2x - y + 7 = 0.$                |
| (d) <u>Having the intercepts <math>a = 3</math> and <math>b = -2</math>.</u> | <i>Ans.</i> $2x - 3y - 6 = 0.$               |
| (e) Slope = -3, intercept on $X$ -axis = 4.                                  | <i>Ans.</i> $3x + y - 12 = 0.$               |
| (f) Intercepts $a = -3$ and $b = -4$ .                                       | <i>Ans.</i> $4x + 3y + 12 = 0.$              |
| (g) Passing through (2, 3) and (-2, -3).                                     | <i>Ans.</i> $3x - 2y = 0.$                   |
| (h) Passing through (3, 4) and (-4, -3).                                     | <i>Ans.</i> $x - y + 1 = 0.$                 |
| (i) Passing through (2, 3) and slope = -2.                                   | <i>Ans.</i> $2x + y - 7 = 0.$                |
| (j) Having the intercepts 2 and -5.  | <i>Ans.</i> $\frac{x}{2} - \frac{y}{5} = 1.$ |

2. Find the equation of the line passing through the origin parallel to the line  $2x - 3y = 4$ .

*Ans.*  $2x - 3y = 0.$

3. Find the equation of the line passing through the origin perpendicular to the line  $5x + y - 2 = 0$ .

*Ans.*  $x - 5y = 0.$

4. Find the equation of the line passing through the point (3, 2) parallel to the line  $4x - y - 3 = 0$ .

*Ans.*  $4x - y - 10 = 0.$

5. Find the equation of the line passing through the point (3, 0) perpendicular to the line  $2x + y - 5 = 0$ .

*Ans.*  $x - 2y - 3 = 0.$

6. Find the equation of the line whose intercept on the  $Y$ -axis is 5 which passes through the point (6, 3).

*Ans.*  $x + 3y - 15 = 0.$

7. Find the equation of the line whose intercept on the  $X$ -axis is 3 which is parallel to the line  $x - 4y + 2 = 0$ .

*Ans.*  $x - 4y - 3 = 0.$

8. Find the equation of the line passing through the origin and through the intersection of the lines  $x - 2y + 3 = 0$  and  $x + 2y - 9 = 0$ .

*Ans.*  $x - y = 0.$

9. Find the equation of the straight line whose slope is  $m$  which passes through the point  $P_1(x_1, y_1)$ .

*Ans.*  $y - y_1 = m(x - x_1).$

10. Find the equation of the straight line whose intercepts are  $a$  and  $b$ .

$$\text{Ans. } \frac{x}{a} + \frac{y}{b} = 1.$$

11. Find the equation of the straight line passing through the points  $P_1(x_1, y_1)$  and  $P_2(x_2, y_2)$ .

$$\text{Ans. } (y_2 - y_1)x - (x_2 - x_1)y + x_2y_1 - x_1y_2 = 0.$$

12. Show that the result of the last problem may be put in the form

$$\frac{x - x_1}{x_2 - x_1} = \frac{y - y_1}{y_2 - y_1}.$$

*Hint.* Add and subtract  $x_1y_1$ , factor, transpose, and express as a proportion.

**42. The equation of the straight line in terms of its slope and the coördinates of any point on the line.** In this section and in those immediately following, the Rule in the preceding section is applied to the determination of general forms of the equations of straight lines satisfying pairs of conditions which occur frequently. These general forms will then enable us to write the equations of certain straight lines with the same ease that the equation  $y = mx + b$  enables us to write the equation of the straight line whose slope and intercept on the  $Y$ -axis are given.

**Theorem V. Point-slope form.** *The equation of the straight line which passes through the point  $P_1(x_1, y_1)$  and has the slope  $m$  is*

$$(V) \quad y - y_1 = m(x - x_1).$$

*Proof.* First step. Let the equation of the given line be

$$(1) \quad Ax + By + C = 0.$$

Second step. Then, by hypothesis,

$$(2) \quad Ax_1 + By_1 + C = 0$$

and

$$(3) \quad -\frac{A}{B} = m.$$

Third step. Solving (2) and (3) for  $A$  and  $C$  in terms of  $B$ , we obtain

$$A = -mB \quad \text{and} \quad C = B(mx_1 - y_1).$$

Fourth step. Substituting in (1), we have

$$-mBx + By + B(mx_1 - y_1) = 0.$$

Dividing by  $B$  and transposing,

$$y - y_1 = m(x - x_1). \quad \text{Q. E. D.}$$

If  $P_1$  lies on the  $Y$ -axis,  $x_1 = 0$  and  $y_1 = b$ , so that this equation becomes  $y = mx + b$ .

### 43. The equation of the straight line in terms of its intercepts.

We pass now to the consideration of a line determined by two points, and we consider first the case in which the two points lie on the axes. *This section does not, therefore, apply to lines parallel to one of the axes or to lines passing through the origin, as in the latter case the two points coincide and hence do not determine a line.*

**Theorem VI. Intercept form.** *If  $a$  and  $b$  are the intercepts of a line on the  $X$ - and  $Y$ -axes respectively, then the equation of the line is*

$$(VI) \quad \frac{x}{a} + \frac{y}{b} = 1.$$

*Proof.* First step. Let the equation of the given line be

$$(1) \quad Ax + By + C = 0.$$

Second step. By definition of the intercepts (p. 66), the points  $(a, 0)$  and  $(0, b)$  lie on the line; hence

$$(2) \quad Aa + C = 0,$$

$$(3) \quad Bb + C = 0.$$

Third step. Solving (2) and (3) for  $A$  and  $B$  in terms of  $C$ , we obtain

$$A = -\frac{1}{a}C \quad \text{and} \quad B = -\frac{1}{b}C.$$

Fourth step. Substituting in (1), we have

$$-\frac{1}{a}Cx - \frac{1}{b}Cy + C = 0.$$

Dividing by  $C$  and transposing,

$$\frac{x}{a} + \frac{y}{b} = 1. \quad \text{Q. E. D.}$$

**Ex. 1.** Write the equation of the locus of  $2x - 6y + 3 = 0$  in terms of its intercepts and plot the line.

*Solution.* Transposing the constant term, we have

$$2x - 6y = -3.$$

Dividing by  $-3$ ,

$$\frac{2x}{-3} + 2y = 1,$$

or 
$$\frac{x}{-\frac{3}{2}} + \frac{y}{\frac{1}{2}} = 1.$$

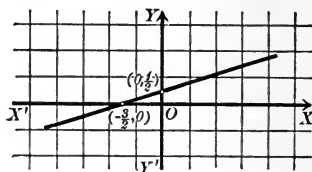

This equation is of the form (VI). Hence

$$a = -\frac{3}{2} \text{ and } b = \frac{1}{2}.$$

Plotting the points  $(-\frac{3}{2}, 0)$  and  $(0, \frac{1}{2})$  and joining them by a straight line, we have the required line.

**44. The equation of the straight line passing through two given points.**

**Theorem VII. Two-point form.** *The equation of the straight line passing through  $P_1(x_1, y_1)$  and  $P_2(x_2, y_2)$  is*

$$(VII) \quad \frac{x - x_1}{x_2 - x_1} = \frac{y - y_1}{y_2 - y_1}.$$

*Proof.* Let the equation of the line be

$$(1) \quad Ax + By + C = 0.$$

Then, by hypothesis,

$$(2) \quad Ax_1 + By_1 + C = 0$$

and

$$(3) \quad Ax_2 + By_2 + C = 0.$$

To follow the Rule, p. 84, we must solve (2) and (3) for  $A$  and  $B$  in terms of  $C$ , substitute in (1), and divide by  $C$ ; that procedure amounts to *eliminating*  $A$ ,  $B$ , and  $C$  from (1), (2), and (3), and that elimination may be more conveniently performed as follows:

Subtract (2) from (1); this gives

$$A(x - x_1) + B(y - y_1) = 0,$$

or

$$(4) \quad A(x - x_1) = -B(y - y_1).$$

Similarly, subtracting (2) from (3), we obtain

$$(5) \quad A(x_2 - x_1) = -B(y_2 - y_1).$$

Dividing (4) by (5), we find

$$\frac{x - x_1}{x_2 - x_1} = \frac{y - y_1}{y_2 - y_1}. \quad \text{Q. E. D.}$$

**Corollary.** *The condition that three points,  $P_1(x_1, y_1)$ ,  $P_2(x_2, y_2)$ , and  $P_3(x_3, y_3)$  should lie on a line is that*

$$\frac{x_3 - x_1}{x_2 - x_1} = \frac{y_3 - y_1}{y_2 - y_1}.$$

For this is the condition that  $P_3$  should lie on the line (VII) passing through  $P_1$  and  $P_2$  (Corollary, p. 46).

The *method of proving* the corollary should be remembered rather than the corollary itself, as then the condition may be immediately written down from (VII).

### PROBLEMS

1. Find, by substitution in the proper formulas, the equations of the lines satisfying the conditions in problem 1, p. 85.

2. Find the equations of the lines fulfilling the following conditions and plot the lines.

- (a) Passing through the origin, slope = 3.  $y = 11x + 5$  *Ans.*  $3x - y = 0$ .  
 (b) Passing through (3, -2) and (0, -1).  $y - y_1 = \frac{y_2 - y_1}{x_2 - x_1}(x - x_1)$  *Ans.*  $x + 3y + 3 = 0$ .  
 (c) Having the intercepts 4 and -3.  $\frac{x}{a} + \frac{y}{b} = 1$  *Ans.*  $3x - 4y - 12 = 0$ .  
 (d) Y-intercept = 5 and slope = 3.  $y = mx + b$  *Ans.*  $3x - y + 5 = 0$ .  
 (e) Passing through (1, -2) and (3, -4).  $y - y_1 = \frac{y_2 - y_1}{x_2 - x_1}(x - x_1)$  *Ans.*  $x + y + 1 = 0$ .  
 (f) Having the intercepts -1 and -3.  $\frac{x}{a} + \frac{y}{b} = 1$  *Ans.*  $3x + y + 3 = 0$ .  
 (g) Passing through  $(-\frac{1}{2}, \frac{3}{2})$  and slope =  $-\frac{3}{2}$ .  $y - y_1 = m(x - x_1)$  *Ans.*  $4x + 6y - 7 = 0$ .  $y - y_1 = m(x - x_1)$   
 (h) Passing through (0, 0) and slope =  $m$ . *Ans.*  $y = mx$ .

3. Find the equations of the sides of the triangle whose vertices are (-3, 2), (3, -2), and (0, -1).

$$\text{Ans. } 2x + 3y = 0, x + 3y + 3 = 0, \text{ and } x + y + 1 = 0.$$

4. Find the equations of the medians of the triangle in problem 3 and show that they meet in a point.

$$\text{Ans. } x = 0, 7x + 9y + 3 = 0, \text{ and } 5x + 9y + 3 = 0.$$

*Hint.* To show that three lines meet in a point, find the point of intersection of two of them and prove that it lies on the third.

5. Show that the medians of any triangle meet in a point.

*Hint.* Taking one vertex for origin and one side for the  $X$ -axis, the vertices may then be called  $(0, 0)$ ,  $(a, 0)$ , and  $(b, c)$ .

6. Determine whether or not the following sets of points lie on a straight line.

- |  |                  |
|--|------------------|
| (a) $(0, 0)$ , $(1, 1)$ , $(7, 7)$ .                       | <i>Ans.</i> Yes. |
| (b) $(2, 3)$ , $(-4, -6)$ , $(8, 12)$ .                    | <i>Ans.</i> Yes. |
| (c) $(3, 4)$ , $(1, 2)$ , $(5, 1)$ .                       | <i>Ans.</i> No.  |
| (d) $(3, -1)$ , $(-6, 2)$ , $(-\frac{3}{2}, 1)$ .          | <i>Ans.</i> No.  |
| (e) $(5, 6)$ , $(\frac{5}{8}, 1)$ , $(-1, -\frac{5}{8})$ . | <i>Ans.</i> Yes. |
| (f) $(7, 6)$ , $(2, 1)$ , $(6, -2)$ .                      | <i>Ans.</i> No.  |

7. Reduce the following equations to the form (VI) and plot their loci.

- |                         |                         |
|-------------------------|-------------------------|
| (a) $2x + 3y - 6 = 0$ . | (d) $3x + 4y + 1 = 0$ . |
| (b) $x - 3y + 6 = 0$ .  | (e) $2x - 4y - 7 = 0$ . |
| (c) $3x - 4y + 9 = 0$ . | (f) $7x - 6y - 3 = 0$ . |

8. Find the equations of the lines joining the middle points of the sides of the triangle in problem 3 and show that they are parallel to the sides.

*Ans.*  $4x + 6y + 3 = 0$ ,  $x + 3y = 0$ , and  $x + y = 0$ .

9. Find the equation of the line passing through the origin and through the intersection of the lines  $x + 2y = 1$  and  $2x - 4y - 3 = 0$ .

*Ans.*  $x + 10y = 0$ .

10. Show that the diagonals of a square are perpendicular.

*Hint.* Take two sides for the axes and let the length of a side be  $a$ .

11. Show that the line joining the middle points of two sides of a triangle is parallel to the third.

*Hint.* Choose the axes so that the vertices are  $(0, 0)$ ,  $(a, 0)$ , and  $(b, c)$ .

12. Find the equation of the line passing through the point  $(3, -4)$  which has the same slope as the line  $2x - y = 3$ .

*Ans.*  $2x - y - 10 = 0$ .

13. Find the equation of the line passing through the point  $(-1, 4)$  which is parallel to the line  $3x + y + 1 = 0$ .

*Ans.*  $3x + y - 1 = 0$ .

14. Two sides of a parallelogram are  $2x + 3y - 7 = 0$  and  $x - 3y + 4 = 0$ . Find the other two sides if one vertex is the point  $(3, 2)$ .

*Ans.*  $2x + 3y - 12 = 0$  and  $x - 3y + 3 = 0$ .

15. Find the equation of the line passing through the point  $(-2, 3)$  which is perpendicular to the line  $x + 2y = 1$ .

*Ans.*  $2x - y + 7 = 0$ .

16. Show that the three lines  $x - 2y = 0$ ,  $x + 2y - 8 = 0$ , and  $x + 2y - 8 + k(x - 2y) = 0$  meet in a point no matter what value  $k$  has.

17. Derive (V) and (VII) by the Rule on p. 46, using Theorem V, p. 28.

18. Derive (VI) and (VII) by the Rule on p. 46, using the theorem that the corresponding sides of similar triangles are proportional.

19. Derive  $y = mx + b$  and (V) by the Rule on p. 46, using the definition of the tangent of an acute angle in a right triangle.

20. Derive the equation of the straight line in terms of the perpendicular distance  $p$  from the origin to the line and the angle  $\omega$  which that perpendicular makes with the positive direction of the  $X$ -axis.

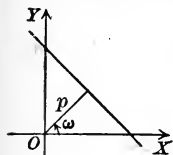

*Hint.* Find the intercepts in terms of  $p$  and  $\omega$  by solving the right triangles in the figure and substitute in (VI).

$$\text{Ans. } x \cos \omega + y \sin \omega - p = 0.$$

21. What is the locus of (V) if  $x_1$  and  $y_1$  are constant and  $m$  arbitrary?

22. What is the locus of (VI) if  $a$  is constant and  $b$  arbitrary? if  $b$  is constant and  $a$  arbitrary?

23. Write an equation which represents all lines passing through  $(2, -1)$ .

24. Write an equation representing all lines whose intercept on the  $X$ -axis is 3.

25. Write in two different forms the equation of all lines whose intercept on the  $Y$ -axis is  $-2$ .

26. Write an equation representing all lines whose slope is  $-\frac{1}{2}$ .

27. If the axes are oblique and make an angle of  $\omega$ , then the equation of a straight line in terms of its inclination  $\alpha$  and intercept on the  $Y$ -axis  $b$  is

$$y = \frac{\sin \alpha}{\sin(\omega - \alpha)} x + b.$$

28. If the angle between the axes is  $\omega$ , the equation of the line passing through  $P_1(x_1, y_1)$  whose inclination is  $\alpha$  is

$$y - y_1 = \frac{\sin \alpha}{\sin(\omega - \alpha)} (x - x_1).$$

29. Show that equations (VI) and (VII) hold for oblique coördinates.

### 45. The normal form of the equation of the straight line.

In the preceding sections the lines considered were determined by two points or by a point and a direction. Both of these methods of determining a line are frequently used in Elementary Geometry, but we have now to consider a line as determined by two conditions which belong essentially to Analytic Geometry.

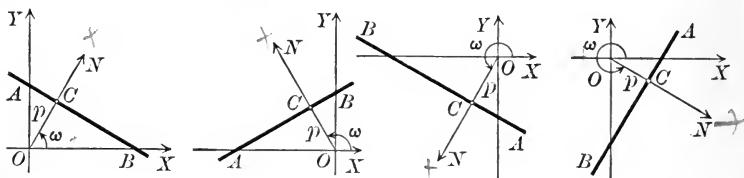

Let  $AB$  be any line, and let  $ON$  be drawn from the origin perpendicular to  $AB$  at  $C$ . Let the positive direction on  $ON$  be from  $O$  toward  $N$ , — that is, from the origin toward the line, — and denote the positive directed length  $OC$  by  $p$  and the positive angle  $XON$ , measured, as in Trigonometry (p. 11), from  $OX$  as initial line to  $ON$  as terminal line, by  $\omega$ .\* Then it is evident from the figures that the position of any line is determined by a pair of values of  $p$  and  $\omega$ , both  $p$  and  $\omega$  being positive and  $\omega < 2\pi$ .

On the other hand, every line determines a single positive value of  $p$  and a single positive value of  $\omega$  which is less than

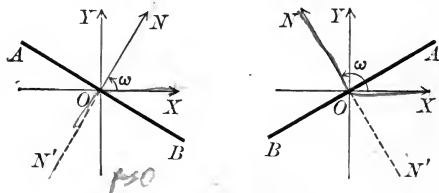

$2\pi$ , unless  $p = 0$ . When  $p = 0$ , however,  $AB$  passes through the origin, and the rule given above for the positive direction on  $ON$  becomes meaningless. From the figures we see that we can choose for  $\omega$  either of the angles  $XON$  or  $XON'$ . When  $p = 0$  we shall always suppose that  $\omega < \pi$  and that the positive direction on  $ON$  is the upward direction.

\*  $\omega$  is not the angle between the directed lines  $OX$  and  $ON$ , as defined on p. 21.



**Theorem VIII.** *The normal form\* of the equation of the straight line is*

$$(VIII) \quad x \cos \omega + y \sin \omega - p = 0,$$

where  $p$  is the perpendicular distance or normal from the origin to the line and  $\omega$  is the positive angle which that perpendicular makes with the positive direction  $OX$  of the  $X$ -axis regarded as initial line.

*Proof.* Let  $P(x, y)$  be any point on the given line  $AB$ .

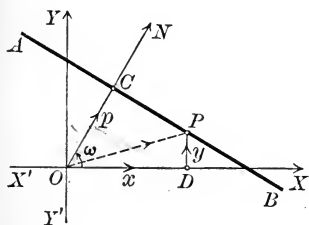

Then since  $AB$  is perpendicular to  $ON$ , the projection of  $OP$  on  $ON$  is equal to  $p$  (definition, p. 22). By the second theorem of projection (p. 41), the projection of  $OP$  on  $ON$  is equal to the sum of the projections of  $OD$  and  $DP$  on  $ON$ . Then the condition that  $P$  lies on  $AB$  is

$$(1) \quad \text{proj. of } OD \text{ on } ON + \text{proj. of } DP \text{ on } ON = p.$$

By the first theorem of projection (p. 23) we have

$$(2) \quad \text{proj. of } OD \text{ on } ON = OD \cos \omega = x \cos \omega,$$

$$(3) \quad \text{proj. of } DP \text{ on } ON = DP \cos \left( \frac{\pi}{2} - \omega \right) = y \sin \omega.$$

For the angle between the directed lines  $DP$  and  $ON$  equals that between  $OY$  and  $ON = \frac{\pi}{2} - \omega$ .

Substituting from (2) and (3) in (1), we obtain

$$x \cos \omega + y \sin \omega - p = 0.$$

Q. E. D.

*To reduce a given equation*

$$(4) \quad Ax + By + C = 0$$

to the normal form, we must determine  $\omega$  and  $p$  so that the locus of (4) is identical with the locus of

$$(5) \quad x \cos \omega + y \sin \omega - p = 0.$$

\*The designation of this equation is made clear by the definition of the normal in Chapter IX.

Then we must have corresponding coefficients proportional (Theorem III, p. 79).

$$\therefore \frac{\cos \omega}{A} = \frac{\sin \omega}{B} = \frac{-p}{C}.$$

Denote the common value of these ratios by  $r$ ; then

$$(6) \quad \cos \omega = rA,$$

$$(7) \quad \sin \omega = rB, \text{ and}$$

$$(8) \quad -p = rC.$$

To find  $r$ , square (6) and (7) and add; this gives

$$\sin^2 \omega + \cos^2 \omega = r^2(A^2 + B^2).$$

$$\text{But} \quad \sin^2 \omega + \cos^2 \omega = 1;$$

$$\text{and hence} \quad r^2(A^2 + B^2) = 1, \text{ or}$$

$$(9) \quad r = \frac{1}{\pm \sqrt{A^2 + B^2}}.$$

Equation (8) shows which sign of the radical to use; for since  $p$  is positive,  $r$  and  $C$  must have *opposite* signs, unless  $C = 0$ . If  $C = 0$ , then, from (8),  $p = 0$ , and hence  $\omega < \pi$  (p. 92); then  $\sin \omega$  is positive, and from (7)  $r$  and  $B$  must have the *same* signs.

Substituting the value of  $r$  from (9) in (6), (7), and (8) gives

$$\cos \omega = \frac{A}{\pm \sqrt{A^2 + B^2}}, \quad \sin \omega = \frac{B}{\pm \sqrt{A^2 + B^2}}, \quad p = -\frac{C}{\pm \sqrt{A^2 + B^2}}.$$

Hence (5) becomes

$$(10) \quad \frac{A}{\pm \sqrt{A^2 + B^2}}x + \frac{B}{\pm \sqrt{A^2 + B^2}}y + \frac{C}{\pm \sqrt{A^2 + B^2}} = 0,$$

which is the normal form of (4). The result of the discussion may be stated in the following

**Rule to reduce  $Ax + By + C = 0$  to the normal form.**

*First step.* Find the numerical value of  $\sqrt{A^2 + B^2}$ .

*Second step.* Give the result of the first step the sign opposite to that of  $C$ , or, if  $C = 0$ , the same sign as that of  $B$ .

*Third step.* Divide the given equation by the result of the second step. The result is the required equation.

The advantages of the normal form of the equation of the straight line over the other forms are twofold. In the first place, *every* line may have its equation in the normal form; whether it is parallel to one of the axes or passes through the origin is immaterial. In the second place, as will be seen in the following section, it enables us to find immediately the distance from a line to a point.

## PROBLEMS

1. In what quadrant will  $ON$  (Fig., p. 92) lie if  $\sin \omega$  and  $\cos \omega$  are both positive? both negative? if  $\sin \omega$  is positive and  $\cos \omega$  negative? if  $\sin \omega$  is negative and  $\cos \omega$  positive?

2. Find the equations and plot the lines for which

(a)  $\omega = 0, p = 5.$

*Ans.*  $x = 5.$

(b)  $\omega = \frac{3\pi}{2}, p = 3.$

*Ans.*  $y + 3 = 0.$

(c)  $\omega = \frac{\pi}{4}, p = 3.$

*Ans.*  $\sqrt{2}x + \sqrt{2}y - 6 = 0.$

(d)  $\omega = \frac{2\pi}{3}, p = 2.$

*Ans.*  $x - \sqrt{3}y + 4 = 0.$

(e)  $\omega = \frac{7\pi}{4}, p = 4.$

*Ans.*  $\sqrt{2}x - \sqrt{2}y - 8 = 0.$

3. Reduce the following equations to the normal form and find  $p$  and  $\omega$ .

(a)  $3x + 4y - 2 = 0.$

*Ans.*  $p = \frac{2}{5}, \omega = \cos^{-1} \frac{3}{5} = \sin^{-1} \frac{4}{5}.$

(b)  $3x - 4y - 2 = 0.$

*Ans.*  $p = \frac{2}{5}, \omega = \cos^{-1} \frac{3}{5} = \sin^{-1} (-\frac{4}{5}).$

(c)  $12x - 5y = 0.$

*Ans.*  $p = 0, \omega = \cos^{-1} (-\frac{1}{13}) = \sin^{-1} \frac{5}{13}.$

(d)  $2x + 5y + 7 = 0.$

*Ans.*  $p = \frac{7}{\sqrt{29}}, \omega = \cos^{-1} \left( \frac{2}{-\sqrt{29}} \right) = \sin^{-1} \left( \frac{5}{-\sqrt{29}} \right).$

(e)  $4x - 3y + 1 = 0.$

*Ans.*  $p = \frac{1}{5}, \omega = \cos^{-1} (-\frac{4}{5}) = \sin^{-1} \frac{3}{5}.$

(f)  $4x - 5y + 6 = 0.$

*Ans.*  $p = \frac{6}{\sqrt{41}}, \omega = \cos^{-1} \left( \frac{4}{-\sqrt{41}} \right) = \sin^{-1} \left( \frac{5}{\sqrt{41}} \right).$

4. Find the perpendicular distance from the origin to each of the following lines.

(a)  $12x + 5y - 26 = 0.$

*Ans.* 2.

(b)  $x + y + 1 = 0.$

*Ans.*  $\frac{1}{2}\sqrt{2}.$

(c)  $3x - 2y - 1 = 0.$

*Ans.*  $\frac{1}{13}\sqrt{13}.$

5. Derive (VIII) when (a)  $\frac{\pi}{2} < \omega < \pi$ ; (b)  $\pi < \omega < \frac{3\pi}{2}$ ; (c)  $\frac{3\pi}{2} < \omega < 2\pi$ ; (d)  $p = 0$  and  $0 < \omega < \frac{\pi}{2}$ .

6. For what values of  $p$  and  $\omega$  will the locus of (VIII) be parallel to the  $X$ -axis? the  $Y$ -axis? pass through the origin?

7. Find the equations of the lines whose slopes equal  $-2$ , which are at a distance of 5 from the origin.

$$\text{Ans. } 2\sqrt{5}x + \sqrt{5}y - 25 = 0 \text{ and } 2\sqrt{5}x + \sqrt{5}y + 25 = 0.$$

8. Find the lines whose distance from the origin is 10, which pass through the point  $(5, 10)$ .

$$\text{Ans. } y = 10 \text{ and } 4x + 3y = 50.$$

9. What is the locus of (VIII) if  $p$  is constant and  $\omega$  arbitrary? if  $\omega$  is constant and  $p$  arbitrary?

10. Write an equation representing all lines whose distance from the origin is 5.

**46. The distance from a line to a point.** The positive direction on the normal  $ON$  drawn through the origin perpendicular to  $AB$  (Fig. 1) is *from  $O$  to  $AB$*  (p. 92); and when  $AB$  passes through  $O$  (Fig. 2) the positive direction on  $ON$  is the *upward* direction.

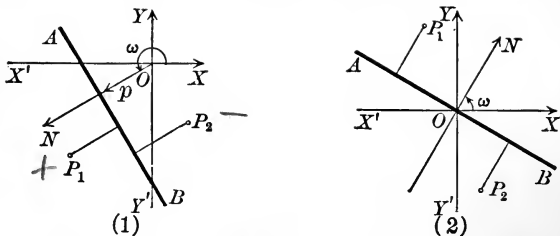

The positive direction on  $ON$  is taken to be the *positive direction* on all lines perpendicular to  $AB$ . Hence the distance *from the line  $AB$  to the point  $P_1$*  is positive if  $P_1$  and the origin are on opposite sides of  $AB$ , and negative if  $P_1$  and the origin are on the same side of  $AB$ . When  $AB$  passes through the origin, the distance *from  $AB$  to  $P_1$*  is positive if that distance is in the upward direction, and negative if it is in the downward direction. Thus in the figures the distance from  $AB$  to  $P_1$  is positive and from  $AB$  to  $P_2$  is negative.

**Theorem IX.** *The distance  $d$  from the line*

$$x \cos \omega + y \sin \omega - p = 0$$

*to the point  $P_1(x_1, y_1)$  is*

$$(IX) \quad d = x_1 \cos \omega + y_1 \sin \omega - p.$$

*Proof.* Let  $AB$  be the given line and let  $ON$  be perpendicular to  $AB$ . By the second theorem of projection (p. 41) we have  
proj. of  $OP_1$  on  $ON$  = proj. of  $OD$  on  $ON$  + proj. of  $DP_1$  on  $ON$ .

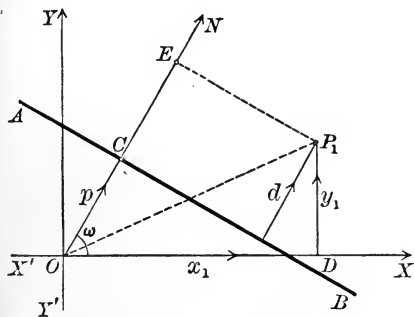

From the figure,

$$\begin{aligned} \text{proj. of } OP_1 \text{ on } ON \\ = OE = p + d. \end{aligned}$$

By the first theorem of projection (p. 23),

$$\begin{aligned} \text{proj. of } OD \text{ on } ON \\ = OD \cos \omega = x_1 \cos \omega, \end{aligned}$$

$$\begin{aligned} \text{proj. of } DP_1 \text{ on } ON \\ = DP_1 \cos \left( \frac{\pi}{2} - \omega \right) \\ = y_1 \sin \omega. \end{aligned}$$

Hence  
and therefore

$$\begin{aligned} p + d &= x_1 \cos \omega + y_1 \sin \omega, \\ \boxed{d} &= x_1 \cos \omega + y_1 \sin \omega - p. \end{aligned} \quad \text{Q.E.D.}$$

From this theorem we have at once the

Rule to find the perpendicular distance from a given line to a given point.

First step. Reduce the equation of the given line to the normal form (Rule, p. 94).

Second step. Substitute the coordinates of the given point for  $x$  and  $y$  in the left-hand side of the equation. The result is the required distance.

The sign of the result will show on which side of the line the point lies.

**Ex. 1.** Find the distance from the line  $4x - 3y + 15 = 0$  to the point  $(2, 1)$ .

*Solution.* First step. Reducing the given equation to normal form, we have

$$-\frac{4}{5}x + \frac{3}{5}y - 3 = 0.$$

Second step. Substituting 2 for  $x$  and 1 for  $y$ , we have

$$d = -\frac{4}{5} \cdot 2 + \frac{3}{5}(1) - 3 = -4.$$

What does the negative sign mean? *below axis*

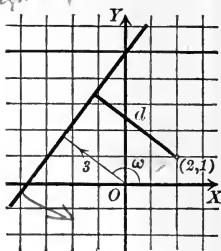

**Ex. 2.** Prove that the sum of the distances from the legs of an isosceles triangle to any point in the base is constant.

*Solution.* Take the middle point of the base for origin and the base itself for the  $X$ -axis. Then the values of  $p$  for the two legs are equal and the values of  $\omega$  are supplementary. Hence, if the equation of one leg in normal form is

$$x \cos \omega + y \sin \omega - p = 0,$$

then the equation of the other leg is.

$$x \cos(\pi - \omega) + y \sin(\pi - \omega) - p = 0,$$

or

$$-x \cos \omega + y \sin \omega - p = 0.$$

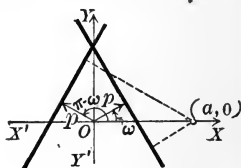

Let  $(a, 0)$  be any point in the base. Then the distances from the legs to  $(a, 0)$  are respectively  $a \cos \omega - p$  and  $-a \cos \omega - p$ , so that the sum of these distances is  $-2p$ , that is, a constant.

### PROBLEMS

1. Find the distance from the line

(a)  $x \cos 45^\circ + y \sin 45^\circ - \sqrt{2} = 0$  to  $(5, -7)$ .

Ans.  $-2\sqrt{2}$ .

(b)  $\frac{3}{5}x - \frac{4}{5}y - 1 = 0$  to  $(2, 1)$ .

Ans.  $-\frac{3}{5}$ .

(c)  $3x + 4y + 15 = 0$  to  $(-2, 3)$ .

Ans.  $-\frac{23}{5}$ .

(d)  $2x - 7y + 8 = 0$  to  $(3, -5)$ .

Ans.  $-\frac{49}{\sqrt{53}}$ .

(e)  $x - 3y = 0$  to  $(0, 4)$ .

Ans.  $\frac{12}{\sqrt{10}}$ .

2. Do the origin and the point  $(3, -2)$  lie on the same side of the line  $x - y + 1 = 0$ ?

Ans. Yes.

3. Does the line  $2x + 3y + 2 = 0$  pass between the origin and the point  $(-2, 3)$ ? *Ans.* No.

4. Find the lengths of the altitudes of the triangle formed by the lines  $2x + 3y = 0$ ,  $x + 3y + 3 = 0$ , and  $x + y + 1 = 0$ .  
*Ans.*  $\frac{3}{\sqrt{13}}$ ,  $\frac{6}{\sqrt{10}}$ , and  $\sqrt{2}$ .

5. Find the distance from the line  $Ax + By + C = 0$  to the point  $P_1(x_1, y_1)$ .  
*Ans.*  $\frac{Ax_1 + By_1 + C}{\pm \sqrt{A^2 + B^2}}$ .

6. Prove Theorem IX when

(a)  $p = 0$ ,  $\omega < \frac{\pi}{2}$ ; (b)  $\frac{\pi}{2} < \omega < \pi$ ; (c)  $\pi < \omega < \frac{3\pi}{2}$ ; (d)  $\frac{3\pi}{2} < \omega < 2\pi$ .

7. Find the locus of all points which are equally distant from

$$3x - 4y + 1 = 0 \text{ and } 4x + 3y - 1 = 0.$$

*Ans.*  $7x - y = 0$  and  $x + 7y - 2 = 0$ .

8. Find the locus of all points which are twice as far from the line  $12x + 5y - 1 = 0$  as from the  $Y$ -axis. *Ans.*  $14x - 5y + 1 = 0$ .

9. Find the locus of points which are  $k$  times as far from  $4x - 3y + 1 = 0$  as from  $5x - 12y = 0$ . *Ans.*  $(52 - 25k)x - (39 - 60k)y + 13 = 0$ .

10. Find the bisectors of the angles formed by the lines in problem 9.

*Ans.*  $77x - 99y + 13 = 0$  and  $27x + 21y + 13 = 0$ .

11. Find the distance between the parallel lines,

(a)  $\begin{cases} y = 2x + 5, \\ y = 2x - 3. \end{cases}$  *Ans.*  $\frac{8}{\sqrt{5}}$ . (c)  $\begin{cases} 2x - 3y + 4 = 0, \\ 4x - 6y + 9 = 0. \end{cases}$  *Ans.*  $\frac{1}{2\sqrt{13}}$ .

(b)  $\begin{cases} y = -3x + 1, \\ y = -3x + 4. \end{cases}$  *Ans.*  $\frac{3}{\sqrt{10}}$ . (d)  $\begin{cases} y = mx + 3, \\ y = mx - 3. \end{cases}$  *Ans.*  $\frac{6}{\sqrt{1+m^2}}$ .

12. Derive the normal equation of the line by means of Theorem IX.

13. Prove that the altitudes on the legs of an isosceles triangle are equal.

14. Prove that the three altitudes of an equilateral triangle are equal.

15. Prove that the sum of the distances from the sides of an equilateral triangle to any point is constant.

*Hint.* Take the center of the triangle for origin, with the  $X$ -axis parallel to one side.

16. Find the areas of the triangles formed by the following lines.

- (a)  $2x - 3y + 30 = 0$ ,  $x = 0$ ,  $x + y = 0$ . Ans. 30.  
 (b)  $x + y = 2$ ,  $3x + 4y - 12 = 0$ ,  $x - y + 6 = 0$ . Ans.  $1\frac{1}{2}$ .  
 (c)  $3x - 4y + 12 = 0$ ,  $x - 3y + 6 = 0$ ,  $2x - y = 0$ . Ans.  $3\frac{3}{4}$ .  
 (d)  $x + 3y - 3 = 0$ ,  $5x - y - 15 = 0$ ,  $x - y + 1 = 0$ . Ans. 8.

17. Plot the following lines and find the area of the quadrilaterals of which they are the sides.

- (a)  $x = y$ ,  $y = 6$ ,  $x + y = 0$ ,  $3x + 2y - 6 = 0$ . Ans.  $16\frac{1}{2}$ .  
 (b)  $x + 2y - 5 = 0$ ,  $y = 0$ ,  $x + 4y + 5 = 0$ ,  $2x + y - 4 = 0$ . Ans. 18.  
 (c)  $2x - 4y + 8 = 0$ ,  $x + y = 0$ ,  $2x - y - 4 = 0$ ,  $2x + y - 3 = 0$ . Ans.  $4\frac{71}{120}$ .

47. **The angle which a line makes with a second line.** The angle between two directed lines has been defined (p. 21) as the angle between their positive directions. When a line is given by means of its equation, no positive direction along the line is fixed. In order to distinguish between the two pairs of equal angles which two intersecting lines make with each other we define the **angle which a line makes with a second line** to be the positive angle (p. 11) from the *second* line to the *first* line.

Thus the angle which  $L_1$  makes with  $L_2$  is the angle  $\theta$ . We speak always of the "angle which one line makes with a second line," and the use of the phrase "the angle between two lines" should be avoided if those lines are not directed lines. We have thus added a third method of designating angles to those given on p. 11 and p. 21.

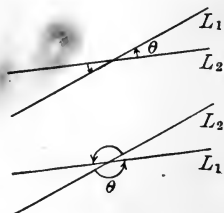

**Theorem X.** *The angle  $\theta$  which the line*

$$L_1 : A_1x + B_1y + C_1 = 0$$

*makes with the line*

$$L_2 : A_2x + B_2y + C_2 = 0$$

*is given by*

$$(X) \quad \tan \theta = \frac{A_2B_1 - A_1B_2}{A_1A_2 + B_1B_2}$$



*Proof.* Let  $\alpha_1$  and  $\alpha_2$  be the inclinations of  $L_1$  and  $L_2$  respectively. Then, since the exterior angle of a triangle equals the sum of the two opposite interior angles, we have

$$\text{In Fig. 1, } \alpha_1 = \theta + \alpha_2, \quad \text{or } \theta = \alpha_1 - \alpha_2,$$

$$\text{In Fig. 2, } \alpha_2 = \pi - \theta + \alpha_1, \quad \text{or } \theta = \pi + (\alpha_1 - \alpha_2).$$

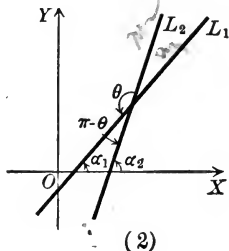
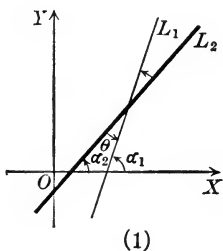

And since (5, p. 13)

$$\tan(\pi + \phi) = \tan \phi,$$

we have, in either case,

$$\begin{aligned} \tan \theta &= \tan(\alpha_1 - \alpha_2) \\ &= \frac{\tan \alpha_1 - \tan \alpha_2}{1 + \tan \alpha_1 \tan \alpha_2}. \quad (\text{by 13, p. 13}) \end{aligned}$$

But  $\tan \alpha_1$  is the slope of  $L_1$  and  $\tan \alpha_2$  is the slope of  $L_2$ ; hence (Corollary I, p. 77)

$$\tan \theta = \frac{-\frac{A_1}{B_1} + \frac{A_2}{B_2}}{1 + \left(-\frac{A_1}{B_1}\right)\left(-\frac{A_2}{B_2}\right)}.$$

$$\text{Reducing, we get } \tan \theta = \frac{A_2 B_1 - A_1 B_2}{A_1 A_2 + B_1 B_2}.$$

Q. E. D.

**Corollary.** If  $m_1$  and  $m_2$  are the slopes of two lines, then the angle  $\theta$  which the first line makes with the second is given by

$$\tan \theta = \frac{m_1 - m_2}{1 + m_1 m_2}.$$

Ex. 1. Find the angles of the triangle formed by the lines whose equations are

$$L: 2x - 3y - 6 = 0,$$

$$M: 6x - y - 6 = 0,$$

$$N: 6x + 4y - 25 = 0.$$

*Solution.* To see which angles formed by the given lines are the angles of the triangle, we plot the lines, obtaining the triangle  $ABC$ .  $A$  is the angle which  $M$  makes with  $L$ , so that  $M$  takes the place of  $L_1$  in Theorem X and  $L$  of  $L_2$ .

Hence

$$A_1 = 6, B_1 = -1;$$

$$A_2 = 2, B_2 = -3.$$

Then

$$\tan A = \frac{A_2B_1 - A_1B_2}{A_1A_2 + B_1B_2} = \frac{-2 + 18}{12 + 3} = \frac{16}{15},$$

and hence

$$A = \tan^{-1}\left(\frac{16}{15}\right).$$

$B$  is the angle which  $L$  makes with  $N$ , and by Corollary III, p. 78,  $B = \frac{\pi}{2}$ .  $C$  is the angle which  $N$  makes with  $M$ , so that if

$$\tan C = \frac{A_2B_1 - A_1B_2}{A_1A_2 + B_1B_2},$$

we must set

$$A_1 = 6, B_1 = 4;$$

$$A_2 = 6, B_2 = -1.$$

Hence

$$\tan C = \frac{24 + 6}{36 - 4} = \frac{30}{32} = \frac{15}{16},$$

and

$$C = \tan^{-1}\left(\frac{15}{16}\right).$$

We may verify these results. For if  $B = \frac{\pi}{2}$ , then  $A = \frac{\pi}{2} - C$ ; and hence (6, p. 13, and 1, p. 12)  $\tan A = \cot C = \frac{1}{\tan C}$ , which is true for the values found.

Ex. 2. Find the equation of the line through  $(3, 5)$  which makes an angle of  $\frac{\pi}{3}$  with the line  $x - y + 6 = 0$ .

*Solution.* Let  $m_1$  be the slope of the required line. Then its equation is (Theorem V, p. 86)

$$(1) \quad y - 5 = m_1(x - 3).$$

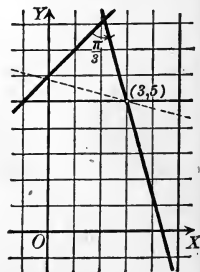
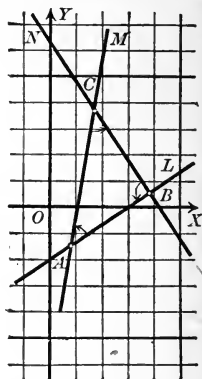

The slope of the given line is  $m_2 = 1$ , and since the angle which (1) makes with the given line is  $\frac{\pi}{3}$ , we have (by the Corollary),

$$\tan \frac{\pi}{3} = \frac{m_1 - 1}{1 + m_1},$$

or

$$\sqrt{3} = \frac{m_1 - 1}{1 + m_1},$$

whence

$$m_1 = \frac{1 + \sqrt{3}}{1 - \sqrt{3}} = -(2 + \sqrt{3}).$$

Substituting in (1), we obtain

$$y - 5 = -(2 + \sqrt{3})(x - 3),$$

or

$$(2 + \sqrt{3})x + y - (11 + 3\sqrt{3}) = 0.$$

In Plane Geometry there would be two solutions of this problem,—the line just obtained and the dotted line of the figure. Why must the latter be excluded here?

### PROBLEMS

1. Find the angle which the line  $3x - y + 2 = 0$  makes with  $2x + y - 2 = 0$ ; also the angle which the second line makes with the first, and show that these angles are supplementary.

$$\text{Ans. } \frac{3\pi}{4}, \frac{\pi}{4}.$$

2. Find the angle which the line

(a)  $2x - 5y + 1 = 0$  makes with the line  $x - 2y + 3 = 0$ .

(b)  $x + y + 1 = 0$  makes with the line  $x - y + 1 = 0$ .

(c)  $3x - 4y + 2 = 0$  makes with the line  $x + 3y - 7 = 0$ .

(d)  $6x - 3y + 3 = 0$  makes with the line  $x = 6$ .

(e)  $x - 7y + 1 = 0$  makes with the line  $x + 2y - 4 = 0$ .

In each case plot the lines and mark the angle found by a small arc.

Ans. (a)  $\tan^{-1}(-\frac{1}{2})$ ; (b)  $\frac{\pi}{2}$ ; (c)  $\tan^{-1}(\frac{1}{3})$ ; (d)  $\tan^{-1}(-\frac{1}{2})$ ; (e)  $\tan^{-1}(\frac{2}{13})$ .

3. Find the angles of the triangle whose sides are  $x + 3y - 4 = 0$ ,  $3x - 2y + 1 = 0$ , and  $x - y + 3 = 0$ . Ans.  $\tan^{-1}(-\frac{1}{3})$ ,  $\tan^{-1}(\frac{1}{3})$ ,  $\tan^{-1}(2)$ .

Hint. Plot the triangle to see which angles formed by the given lines are the angles of the triangle.

4. Find the exterior angles of the triangle formed by the lines  $5x - y + 3 = 0$ ,  $y = 2$ ,  $x - 4y + 3 = 0$ . Ans.  $\tan^{-1}(5)$ ,  $\tan^{-1}(-\frac{1}{4})$ ,  $\tan^{-1}(-\frac{1}{9})$ .

5. Find one exterior angle and the two opposite interior angles of the triangle formed by the lines  $2x - 3y - 6 = 0$ ,  $3x + 4y - 12 = 0$ ,  $x - 3y + 6 = 0$ . Verify the results by formula 12, p. 13.

6. Find the angles of the triangle formed by  $3x + 2y - 4 = 0$ ,  $x - 3y + 6 = 0$ , and  $4x - 3y - 10 = 0$ . Verify the results by the formula

$$\tan A + \tan B + \tan C = \tan A \tan B \tan C, \text{ if } A + B + C = 180^\circ.$$

7. Find the line passing through the given point and making the given angle with the given line.

(a)  $(2, 1), \frac{\pi}{4}, 2x - 3y + 2 = 0.$       *Ans.*  $5x - y - 9 = 0.$

(b)  $(1, -3), \frac{3\pi}{4}, x + 2y + 4 = 0.$       *Ans.*  $3x + y = 0.$

(c)  $(2, -5), \frac{\pi}{4}, x + 3y - 8 = 0.$       *Ans.*  $x - 2y - 12 = 0.$

(d)  $(x_1, y_1), \phi, y = mx + b.$       *Ans.*  $y - y_1 = \frac{m + \tan \phi}{1 - m \tan \phi} (x - x_1).$

(e)  $(x_1, y_1), \phi, Ax + By + C = 0.$       *Ans.*  $y - y_1 = \frac{B \tan \phi - A}{A \tan \phi + B} (x - x_1).$

8. Show from a figure that it is impossible to draw a line through the intersection of two lines and "making equal angles with those lines" in the sense in which we have defined "the angle which one line makes with a second line." Prove the same thing by formula (X). How are the bisectors of the angles of two lines to be defined?

9. Given two lines  $L_1: 3x - 4y - 3 = 0$  and  $L_2: 4x - 3y + 12 = 0$ ; find the equation of the line passing through their point of intersection such that the angle it makes with  $L_1$  is equal to the angle  $L_2$  makes with it.

$$\text{Ans. } 7x - 7y + 9 = 0.$$

**48. Systems of straight lines.** An equation of the first degree in  $x$  and  $y$  which contains a single arbitrary constant will represent an infinite number of lines, for the locus of the equation will be a straight line for any value of the constant, and the locus will be different for different values of the constant.

The lines represented by an equation of the first degree which contains an arbitrary constant are said to form a **system**. An equation which represents all of the lines satisfying a single condition must contain an arbitrary constant, for there is an infinite number of lines satisfying a single condition; hence a single geometrical condition defines a system of lines.

Thus the equation  $y = 2x + b$ , where  $b$  is an arbitrary constant, represents the system of lines having the slope 2; and the equation  $y - 5 = m(x - 3)$ , where  $m$  is an arbitrary constant, represents the system of lines passing through  $(3, 5)$ .

**Second rule to find the equation of a straight line satisfying two conditions.**

*First step.* Write the equation of the system of lines satisfying one condition.

*Second step.* Determine the arbitrary constant in the equation found in the first step so that the other condition is satisfied.

*Third step.* Substitute the result of the second step in the result of the first step. This gives the required equation.

This rule is, in general, easier of application than the rule on p. 84. It has already been applied in solving Ex. 2, p. 102, and will find constant application in the following sections. The number of lines satisfying the conditions imposed will be the number of real values of the arbitrary constant obtained in the second step.

**Ex. 1.** Find the equations of the straight lines having the slope  $\frac{3}{4}$  and intersecting the circle  $x^2 + y^2 = 4$  in but one point.

*Solution.* First step. The equation

$$y = \frac{3}{4}x + b$$

represents the system of lines whose slopes are  $\frac{3}{4}$  (Theorem I, p. 51).

Second step. The coördinates of the intersection of the line and circle are found by solving their equations simultaneously (Rule, p. 69). Substituting the value of  $y$  in the line in the equation of the circle, we have

$$x^2 + (\frac{3}{4}x + b)^2 = 4,$$

$$\text{or } 25x^2 + 24bx + (16b^2 - 64) = 0.$$

The roots of this equation, by hypothesis, must be equal; hence the discriminant must vanish (Theorem II, p. 3); that is,

$$576b^2 - 100(16b^2 - 64) = 0,$$

whence

$$b = \pm \frac{5}{2}.$$

Third step. Substitute these values of  $b$  in the equation of the first step. We thus obtain the two solutions

$$y = \frac{3}{4}x + \frac{5}{2}$$

and

$$y = \frac{3}{4}x - \frac{5}{2}.$$

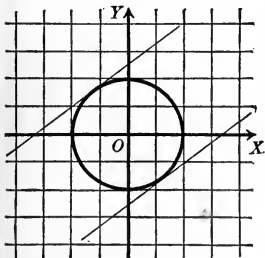

## PROBLEMS

1. Write the equations of the systems of lines defined by the following conditions.

- (a) Passing through  $(-2, 3)$ .  $y - y_1 = m(x - x_1)$   
 (b) Having the slope  $-\frac{2}{3}$ .  
 (c) Distance from the origin is 3.  
 (d) Having the intercept on the  $Y$ -axis  $= -3$ .  
 (e) Passing through  $(6, -1)$ .  
 (f) Having the intercept on the  $X$ -axis  $= 6$ .  
 (g) Having the slope  $\frac{1}{2}$ .  
 (h) Having the intercept on the  $Y$ -axis  $= 5$ .  
 (i) Distance from the origin  $= 4$ .

2. What geometric conditions define the systems of lines represented by the following equations?

- (a)  $2x - 3y + 4k = 0$ .  
 (b)  $kx - 3y - 7 = 0$ .  
 (c)  $x + y - k = 0$ .  
 (d)  $x + k = 0$ .  
 (e)  $x + 2ky - 3 = 0$ .  
 (f)  $2kx - 3y + 2 = 0$ .  
 (g)  $x \cos \alpha + y \sin \alpha + 5 = 0$ .

*Hint.* Reduce the given equation to one of the well-known forms of the equation of the first degree.

3. Determine  $k$  so that

- (a) the line  $2x - 3y + k = 0$  passes through  $(-2, 1)$ . *Ans.*  $k = 7$ .  
 (b) the line  $2kx - 5y + 3 = 0$  has the slope 3. *Ans.*  $k = \frac{1}{2}$ .  
 (c) the line  $x + y - k = 0$  passes through  $(3, 4)$ . *Ans.*  $k = 7$ .  
 (d) the line  $3x - 4y + k = 0$  has intercept on  $X$ -axis  $= 2$ .  
*Ans.*  $k = -6$ .  
 (e) the line  $x - 3ky + 4 = 0$  has intercept on  $Y$ -axis  $= -3$ .  
*Ans.*  $k = -\frac{4}{9}$ .  
 (f) the line  $4x - 3y + 6k = 0$  is distant three units from the origin.  
*Ans.*  $k = \pm \frac{5}{2}$ .

4. Find the equations of the straight lines with the slope  $-\frac{5}{12}$  which cut the circle  $x^2 + y^2 = 1$  in but one point. *Ans.*  $5x + 12y = \pm 13$ .

5. Find the equations of the lines passing through the point  $(1, 2)$  which cut the circle  $x^2 + y^2 = 4$  in but one point. *Ans.*  $y = 2$  and  $4x + 3y = 10$ .

6. Find the equation of the straight line passing through  $(-2, 5)$  which makes an angle of  $45^\circ$  with the  $Y$ -axis. *Ans.*  $x + y - 3 = 0$ .

7. Find the equation of the straight line which passes through the point  $(2, -1)$  and which is at a distance of two units from the origin.

*Ans.*  $x = 2$  and  $3x - 4y = 10$ .

8. Find the equation of the straight line whose slope is  $\frac{3}{4}$  such that the distance from the line to the point  $(2, 4)$  is 2.

*Ans.*  $3x - 4y = 0$ .

**49. The system of lines parallel to a given line.**

**Theorem XI.** *The system of lines parallel to a given line*

$$Ax + By + C = 0$$

*is represented by*

(XI)  $Ax + By + k = 0,$

*where  $k$  is an arbitrary constant.*

*Proof.* All of the lines of the system represented by (XI) are parallel to the given line (Corollary II, p. 78). It remains to be shown that *all* lines parallel to the given line are represented by (XI). Any line parallel to the given line is determined by some point  $P_1(x_1, y_1)$  through which it passes. If  $P_1$  lies on (XI),

then  $Ax_1 + By_1 + k = 0;$

and hence  $k = -Ax_1 - By_1.$

That is, the value of  $k$  may be chosen so that the locus of (XI) passes through *any* point  $P_1$ . Then (XI) represents *all* lines parallel to the given line. Q.E.D.

It should be noticed that the coefficients of  $x$  and  $y$  in (XI) are the same as those of the given equation.

**Ex. 1.** Find the equation of the line through the point  $P_1(3, -2)$  parallel to the line  $L_1: 2x - 3y - 4 = 0$ .

*Solution.* Apply the Rule, p. 105.

First step. The system of lines parallel to the given line is

$$2x - 3y + k = 0.$$

Second step. The required line passes through  $P_1$ ; hence

$$2 \cdot 3 - 3(-2) + k = 0,$$

and therefore  $k = -12$ .

Third step. Substituting this value of  $k$ , the required equation is

$$2x - 3y - 12 = 0.$$

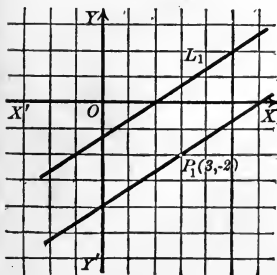

**50. The system of lines perpendicular to a given line.**

**Theorem XII.** *The system of lines perpendicular to the given line*

$$Ax + By + C = 0$$

*is represented by*

$$(XII) \quad Bx - Ay + k = 0,$$

*where  $k$  is an arbitrary constant.*

*Proof.* All of the lines of the system represented by (XII) are perpendicular to the given line, for (Corollary III, p. 78)  $AB - BA = 0$ . It remains to be shown that *all* lines perpendicular to the given line are represented by (XII). Any line perpendicular to the given line is determined by some point  $P_1(x_1, y_1)$  through which it passes. If  $P_1$  lies on (XII), then

$$Bx_1 - Ay_1 + k = 0,$$

whence

$$k = Ay_1 - Bx_1.$$

That is, the value of  $k$  may be chosen so that the locus of (XII) passes through *any* point  $P_1$ . Then (XII) represents all lines perpendicular to the given line. Q.E.D.

Notice that the coefficients of  $x$  and  $y$  in (XII) are respectively the coefficients of  $y$  and  $x$  in the given equation with the sign of one of them changed.

**Ex. 1.** Find the equation of the line through the point  $P_1(-1, 3)$  perpendicular to the line  $L_1: 5x - 2y + 3 = 0$ .

*Solution.* Apply the Rule, p. 105.

First step. The equation of the system of lines perpendicular to the given line is

$$2x + 5y + k = 0.$$

Second step. The required line passes through  $P_1$ ; hence

$$2(-1) + 5 \cdot 3 + k = 0,$$

or 
$$k = -13.$$

Third step. Substitute this value of  $k$ . The required equation is then

$$2x + 5y - 13 = 0.$$

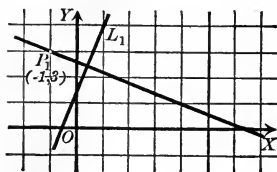



## PROBLEMS

1. Find the equation of the straight line which passes through the point

(a)  $(0, 0)$  and is parallel to  $x - 3y + 4 = 0$ . *Ans.*  $x - 3y = 0$ .

(b)  $(3, -2)$  and is parallel to  $x + y + 2 = 0$ . *Ans.*  $x + y - 1 = 0$ .

(c)  $(-5, 6)$  and is parallel to  $2x + 4y - 3 = 0$ . *Ans.*  $x + 2y - 7 = 0$ .

(d)  $(-1, 2)$  and is perpendicular to  $3x - 4y + 1 = 0$ .

*Ans.*  $4x + 3y - 2 = 0$ .

(e)  $(-7, 2)$  and is perpendicular to  $x - 3y + 4 = 0$ .

*Ans.*  $3x + y + 19 = 0$ .

2. Find the equations of the lines drawn through the vertices of the triangle whose vertices are  $(-3, 2)$ ,  $(3, -2)$ , and  $(0, -1)$ , which are parallel to the opposite sides.

*Ans.* The sides of the triangle are

$$2x + 3y = 0, x + 3y + 3 = 0, x + y + 1 = 0.$$

The required equations are

$$2x + 3y + 3 = 0, x + 3y - 3 = 0, x + y - 1 = 0.$$

3. Find the equations of the lines drawn through the vertices of the triangle in problem 2 which are perpendicular to the opposite sides, and show that they meet in a point.

*Ans.*  $3x - 2y - 2 = 0, 3x - y + 11 = 0, x - y - 5 = 0$ .

4. Find the equations of the perpendicular bisectors of the sides of the triangle in problem 2, and show that they meet in a point.

*Ans.*  $3x - 2y = 0, 3x - y - 6 = 0, x - y + 2 = 0$ .

5. The equations of two sides of a parallelogram are  $3x - 4y + 6 = 0$  and  $x + 5y - 10 = 0$ . Find the equations of the other two sides if one vertex is the point  $(4, 9)$ .

*Ans.*  $3x - 4y + 24 = 0$  and  $x + 5y - 49 = 0$ .

6. The vertices of a triangle are  $(2, 1)$ ,  $(-2, 3)$ , and  $(4, -1)$ . Find the equations of (a) the sides of the triangle, (b) the perpendicular bisectors of the sides, and (c) the lines drawn through the vertices perpendicular to the opposite sides. Check the results by showing that the lines in (b) and (c) meet in a point.

7. Show that the perpendicular bisectors of the sides of any triangle meet in a point.

8. Show that the lines drawn through the vertices of a triangle perpendicular to the opposite sides meet in a point.

9. Find the value of  $C$  in terms of  $A$  and  $B$  if  $Ax + By + C = 0$  passes through a given point  $P_1(x_1, y_1)$ ; show that the equation of the system of lines through  $P_1$  may be written  $A(x - x_1) + B(y - y_1) = 0$ .

51. The system of lines passing through the intersection of two given lines.

**Theorem XIII.** *The system of lines passing through the intersection of two given lines*

$$L_1 : A_1x + B_1y + C_1 = 0$$

and

$$L_2 : A_2x + B_2y + C_2 = 0$$

is represented by the equation  $\lambda$

$$(XIII) \quad (A_1x + B_1y + C_1) + k(A_2x + B_2y + C_2) = 0,$$

where  $k$  is an arbitrary constant.

*Proof.* All of the lines represented by (XIII) pass through the intersection of  $L_1$  and  $L_2$ . For let  $P_1(x_1, y_1)$  be the intersection of  $L_1$  and  $L_2$ . Then (Corollary, p. 46)

$$A_1x_1 + B_1y_1 + C_1 = 0$$

and

$$A_2x_1 + B_2y_1 + C_2 = 0.$$

Multiply the second equation by  $k$  and add to the first. This gives

$$A_1x_1 + B_1y_1 + C_1 + k(A_2x_1 + B_2y_1 + C_2) = 0.$$

But this is the condition that  $P_1$  lies on (XIII).

That *all* lines through the intersection of  $L_1$  and  $L_2$  are represented by (XIII) follows as in the proofs of Theorems XI and XII.

Q. E. D.

**Corollary.** *If  $L_1$  and  $L_2$  are parallel, then (XIII) represents the system of lines parallel to  $L_1$  and  $L_2$ .*

For if  $L_1$  and  $L_2$  are parallel, then

$$\frac{A_1}{A_2} = \frac{B_1}{B_2},$$

and hence

$$\frac{A_1}{kA_2} = \frac{B_1}{kB_2}.$$

By composition,

$$\frac{A_1 + kA_2}{A_1} = \frac{B_1 + kB_2}{B_1}.$$

Hence  $L_1$  and (XIII) are parallel (Corollary II, p. 78).

Notice that (XIII) is formed by multiplying the equation of  $L_2$  by  $k$  and adding it to the equation of  $L_1$ .

**Ex. 1.** Find the equation of the line passing through  $P_1(2, 1)$  and the intersection of  $L_1: 3x - 5y - 10 = 0$  and  $L_2: x + y + 1 = 0$ .

*Solution.* Apply the Rule, p. 105. The system of lines passing through the intersection of the given lines is represented by

$$3x - 5y - 10 + k(x + y + 1) = 0.$$

If  $P_1$  lies on this line, then

$$6 - 5 - 10 + k(2 + 1 + 1) = 0;$$

whence  $k = \frac{9}{4}$ .

Substituting this value of  $k$  and simplifying, we have the required equation

$$21x - 11y - 31 = 0.$$

**Ex. 2.** Find the equation of the line passing through the intersection of  $L_1: 2x + y + 1 = 0$  and  $L_2: x - 2y + 1 = 0$  and parallel to  $L_3: 4x - 3y - 7 = 0$ .

*Solution.* Apply the Rule, p. 105. The equation of every line through the intersection of the first two given lines has the form

$$2x + y + 1 + k(x - 2y + 1) = 0,$$

or  $(2 + k)x + (1 - 2k)y + (1 + k) = 0.$

If this line is parallel to the third line (Corollary II, p. 78),

$$\frac{2 + k}{4} = \frac{1 - 2k}{-3};$$

whence  $k = 2.$

Substituting and simplifying, we obtain

$$4x - 3y + 3 = 0.$$

The geometrical significance of the value of  $k$  in Theorem XIII is given most simply when  $L_1$  and  $L_2$  are in normal form.

**Theorem XIV.** *The ratio of the distances from*

$$L_1: x \cos \omega_1 + y \sin \omega_1 - p_1 = 0$$

and  $L_2: x \cos \omega_2 + y \sin \omega_2 - p_2 = 0$

to any point of the line

$$L: x \cos \omega_1 + y \sin \omega_1 - p_1 + k(x \cos \omega_2 + y \sin \omega_2 - p_2) = 0$$

is constant and equal to  $-k$ .

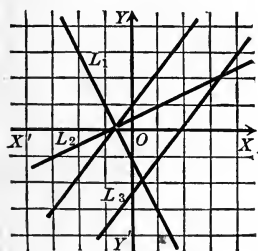
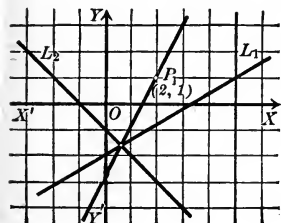

*Proof.* Let  $P_1(x_1, y_1)$  be any point on  $L$ . Then

$$x_1 \cos \omega_1 + y_1 \sin \omega_1 - p_1 + k(x_1 \cos \omega_2 + y_1 \sin \omega_2 - p_2) = 0,$$

and hence 
$$-k = \frac{x_1 \cos \omega_1 + y_1 \sin \omega_1 - p_1}{x_1 \cos \omega_2 + y_1 \sin \omega_2 - p_2}.$$

The numerator of this fraction is the distance from  $L_1$  to  $P_1$ , and the denominator is the distance from  $L_2$  to  $P_1$  (Theorem IX, p. 97). Hence  $-k$  is the ratio of the distances from  $L_1$  and  $L_2$  to any point on  $L$ . Q. E. D.

**Corollary.** *If  $k = \pm 1$ , then  $L$  is the bisector of one of the angles formed by  $L_1$  and  $L_2$ . That is, the equations of the bisectors of the angles between two lines are found by reducing their equations to the normal form and adding and subtracting them.*

For when  $k = \pm 1$  the numerical values of the distances from  $L_1$  and  $L_2$  to any point of  $L$  are equal.

The angle formed by  $L_1$  and  $L_2$  in which the origin lies, or its vertical angle, is called an **internal** angle of  $L_1$  and  $L_2$ ; and either of the other angles formed by  $L_1$  and  $L_2$  is called an **external** angle of those lines. From the rule giving the *sign* of the distance from a line to a point (p. 96) it follows that  $L$  lies in the internal angles of  $L_1$  and  $L_2$  when  $k$  is negative, and in the external angles when  $k$  is positive. If the origin lies on  $L_1$  or  $L_2$ , the lines must in each case be plotted and the angles in which  $k$  is positive found from the figure.

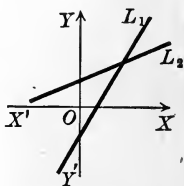

### PROBLEMS

1. Find the equation of the line passing through the intersection of  $2x - 3y + 2 = 0$  and  $3x - 4y - 2 = 0$ , without finding the point of intersection, which

- (a) passes through the origin.
- (b) is parallel to  $5x - 2y + 3 = 0$ .
- (c) is perpendicular to  $3x - 2y + 4 = 0$ .

*Ans.* (a)  $5x - 7y = 0$ ; (b)  $5x - 2y - 50 = 0$ ; (c)  $2x + 3y - 58 = 0$ .

2. Find the equations of the lines which pass through the vertices of the triangle formed by the lines  $2x - 3y + 1 = 0$ ,  $x - y = 0$ , and  $3x + 4y - 2 = 0$  which are

(a) parallel to the opposite sides.

(b) perpendicular to the opposite sides.

*Ans.* (a)  $3x + 4y - 7 = 0$ ,  $14x - 21y + 2 = 0$ ,  $17x - 17y + 5 = 0$ ;

(b)  $4x - 3y - 1 = 0$ ,  $21x + 14y - 10 = 0$ ,  $17x + 17y - 9 = 0$ .

3. Find the bisectors of the angles formed by the lines  $4x - 3y - 1 = 0$  and  $3x - 4y + 2 = 0$ , and show that they are perpendicular.

*Ans.*  $7x - 7y + 1 = 0$  and  $x + y - 3 = 0$ .

4. Find the equations of the bisectors of the angles formed by the lines  $5x - 12y + 10 = 0$  and  $12x - 5y + 15 = 0$ . Verify the results by Theorem X.

5. Find the locus of a point the ratio of whose distances from the lines  $4x - 3y + 4 = 0$  and  $5x + 12y - 8 = 0$  is 13 to 5. *Ans.*  $9x + 9y - 4 = 0$ .

6. Find the bisectors of the interior angles of the triangle formed by the lines  $4x - 3y = 12$ ,  $5x - 12y - 4 = 0$ , and  $12x - 5y - 13 = 0$ . Show that they meet in a point.

*Ans.*  $7x - 9y - 16 = 0$ ,  $7x + 7y - 9 = 0$ ,  $112x - 64y - 221 = 0$ .

7. Find the bisectors of the interior angles of the triangle formed by the lines  $5x - 12y = 0$ ,  $5x + 12y + 60 = 0$ , and  $12x - 5y - 60 = 0$ , and show that they meet in a point.

*Ans.*  $2y + 5 = 0$ ,  $17x + 7y = 0$ ,  $17x - 17y - 60 = 0$ .

8. The sides of a triangle are  $3x + 4y - 12 = 0$ ,  $3x - 4y = 0$ , and  $4x + 3y + 24 = 0$ . Show that the bisector of the interior angle at the vertex formed by the first two lines and the bisectors of the exterior angles at the other vertices meet in a point.

9. Find the equation of the line passing through the intersection of  $x + y - 2 = 0$  and  $x - y + 6 = 0$  and through the intersection of  $2x - y + 3 = 0$  and  $x - 3y + 2 = 0$ .

*Ans.*  $19x + 3y + 26 = 0$ .

*Hint.* The systems of lines passing through the points of intersection of the two pairs of lines are

$$x + y - 2 + k(x - y + 6) = 0$$

and

$$2x - y + 3 + k'(x - 3y + 2) = 0.$$

These lines will coincide if (Theorem III, p. 79)

$$\frac{1+k}{2+k'} = \frac{1-k}{-1-3k'} = \frac{-2+6k}{3+2k'}.$$

Letting  $\rho$  be the common value of these ratios, we obtain

$$1+k = 2\rho + \rho k',$$

$$1-k = -\rho - 3\rho k',$$

and

$$-2+6k = 3\rho + 2\rho k'.$$

From these equations we can eliminate the terms in  $\rho k'$  and  $\rho$ , and thus find the value of  $k$  which gives that line of the first system which also belongs to the second system.

10. Find the equation of the line passing through the intersection of  $2x + 5y - 3 = 0$  and  $3x - 2y - 1 = 0$  and through the intersection of  $x - y = 0$  and  $x + 3y - 6 = 0$ . Ans.  $43x - 35y - 12 = 0$ .

A figure composed of four lines intersecting in six points is called a **complete quadrilateral**. The six vertices determine three diagonals of which two are the diagonals of the ordinary quadrilateral formed by the four lines.

11. Find the equations of the three diagonals of the complete quadrilateral formed by the lines  $x + 2y = 0$ ,  $3x - 4y + 2 = 0$ ,  $x - y + 3 = 0$ , and  $3x - 2y + 4 = 0$ . Ans.  $2x - y + 1 = 0$ ,  $x + 2 = 0$ ,  $5x - 6y + 8 = 0$ .

12. Show that the bisectors of the angles of any two lines are perpendicular.

13. Find a geometrical interpretation of  $k$  in (XI) and (XII).

14. Find the geometrical interpretation of  $k$  in (XIII) when  $L_1$  and  $L_2$  are not in normal form.

15. Show that the bisectors of the interior angles of any triangle meet in a point.

16. Show that the bisectors of two exterior angles of a triangle and of the third interior angle meet in a point.

## CHAPTER V

### THE CIRCLE AND THE EQUATION $x^2 + y^2 + Dx + Ey + F = 0$

**52. The general equation of the circle.** If  $(\alpha, \beta)$  is the center of a circle whose radius is  $r$ , then the equation of the circle is (Theorem II, p. 51)

$$(1) \quad x^2 + y^2 - 2\alpha x - 2\beta y + \alpha^2 + \beta^2 - r^2 = 0,$$

or

$$(2) \quad (x - \alpha)^2 + (y - \beta)^2 = r^2.$$

In particular, if the center is the origin,  $\alpha = 0$ ,  $\beta = 0$ , and (2) reduces to

$$(3) \quad x^2 + y^2 = r^2.$$

Equation (1) is of the form

$$(4) \quad x^2 + y^2 + Dx + Ey + F = 0,$$

where

$$(5) \quad D = -2\alpha, \quad E = -2\beta, \quad \text{and} \quad F = \alpha^2 + \beta^2 - r^2.$$

Can we infer, conversely, that the locus of every equation of the form (4) is a circle? By adding  $\frac{1}{4}D^2 + \frac{1}{4}E^2$  to both members, (4) becomes

$$(6) \quad (x + \frac{1}{2}D)^2 + (y + \frac{1}{2}E)^2 = \frac{1}{4}(D^2 + E^2 - 4F).$$

In (6) we distinguish three cases:

If  $D^2 + E^2 - 4F$  is positive, (6) is in the form (2), and hence the locus of (4) is a circle whose center is  $(-\frac{1}{2}D, -\frac{1}{2}E)$  and whose radius is  $r = \frac{1}{2}\sqrt{D^2 + E^2 - 4F}$ .

If  $D^2 + E^2 - 4F = 0$ , the only real values satisfying (6) are  $x = -\frac{1}{2}D$ ,  $y = -\frac{1}{2}E$  (footnote, p. 52). The locus, therefore, is the single point  $(-\frac{1}{2}D, -\frac{1}{2}E)$ . In this case the locus of (4) is often called a **point-circle**, or a **circle whose radius is zero**.

If  $D^2 + E^2 - 4F$  is negative, no real values satisfy (6), and hence (4) has no locus.

The expression  $D^2 + E^2 - 4F$  is called the discriminant of (4), and is denoted by  $\Theta$ . The result is given by

**Theorem I.** *The locus of the equation*

$$(I) \quad x^2 + y^2 + Dx + Ey + F = 0,$$

whose discriminant is  $\Theta = D^2 + E^2 - 4F$ , is determined as follows:

(a) When  $\Theta$  is positive the locus is the circle whose center is  $(-\frac{1}{2}D, -\frac{1}{2}E)$  and whose radius is  $r = \frac{1}{2}\sqrt{D^2 + E^2 - 4F} = \frac{1}{2}\sqrt{\Theta}$ .

(b) When  $\Theta$  is zero the locus is the point-circle  $(-\frac{1}{2}D, -\frac{1}{2}E)$ .

(c) When  $\Theta$  is negative there is no locus.

**Corollary.** *When  $E = 0$  the center of (I) is on the X-axis, and when  $D = 0$  the center is on the Y-axis.*

Whenever in what follows it is said that (I) is the equation of a circle it is assumed that  $\Theta$  is positive.

**Ex. 1.** Find the locus of the equation  $x^2 + y^2 - 4x + 8y - 5 = 0$ .

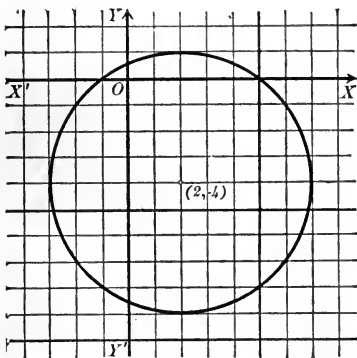

*Solution.* The given equation is of the form (I), where

$$D = -4, E = 8, F = -5,$$

and hence

$$\Theta = 16 + 64 + 20 = 100 > 0.$$

The locus is therefore a circle whose center is the point  $(2, -4)$  and whose radius is  $\frac{1}{2}\sqrt{100} = 5$ .

The equation  $Ax^2 + Bxy + Cy^2 + Dx + Ey + F = 0$  is called the general equation of the second degree in  $x$  and  $y$  because it contains all

possible terms in  $x$  and  $y$  of the second and lower degrees. This equation can be reduced to the form (I) when and only when  $A = C$  and  $B = 0$ . Hence the locus of an equation of the second degree is a circle only when the coefficients of  $x^2$  and  $y^2$  are equal and the  $xy$ -term is lacking.

**53. Circles determined by three conditions.** The equation of any circle may be written in either one of the forms

$$(x - \alpha)^2 + (y - \beta)^2 = r^2$$

or

$$x^2 + y^2 + Dx + Ey + F = 0.$$



Each of these equations contains three arbitrary constants. To determine these constants three equations are necessary, and as any equation between the constants means that the circle satisfies some geometrical condition, it follows that a circle may be determined to satisfy three conditions.

**Rule to determine the equation of a circle satisfying three conditions.**

*First step.* Let the required equation be

$$(1) \quad (x - \alpha)^2 + (y - \beta)^2 = r^2$$

or

$$(2) \quad x^2 + y^2 + Dx + Ey + F = 0,$$

as may be more convenient.

*Second step.* Find three equations between the constants  $\alpha$ ,  $\beta$ , and  $r$  [or  $D$ ,  $E$ , and  $F$ ] which express that the circle (1) [or (2)] satisfies the three given conditions.

*Third step.* Solve the equations found in the second step for  $\alpha$ ,  $\beta$ , and  $r$  [or  $D$ ,  $E$ , and  $F$ ].

*Fourth step.* Substitute the results of the third step in (1) [or (2)]. The result is the required equation.

**Ex. 1.** Find the equation of the circle passing through the three points  $P_1(0, 1)$ ,  $P_2(0, 6)$ , and  $P_3(3, 0)$ .

*Solution.* First step. Let the required equation be

$$(3) \quad x^2 + y^2 + Dx + Ey + F = 0.$$

Second step. Since  $P_1$ ,  $P_2$ , and  $P_3$  lie on (3), their coordinates must satisfy (3). Hence we have

$$(4) \quad 1 + E + F = 0,$$

$$(5) \quad 36 + 6E + F = 0,$$

and

$$(6) \quad 9 + 3D + F = 0.$$

Third step. Solving (4), (5), and (6), we obtain

$$E = -7, \quad F = 6, \quad D = -5.$$

Fourth step. Substituting in (3), the required equation is

$$x^2 + y^2 - 5x - 7y + 6 = 0.$$

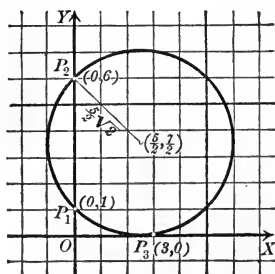

By Theorem I we find that the radius is  $\frac{5}{2}\sqrt{2}$ \* and the center is the point  $(\frac{5}{2}, \frac{7}{2})$ .

**Ex. 2.** Find the equation of the circle passing through the points  $P_1(0, -3)$  and  $P_2(4, 0)$  which has its center on the line  $x + 2y = 0$ .

*Solution.* First step. Let the required equation be

$$(7) \quad x^2 + y^2 + Dx + Ey + F = 0.$$

Second step. Since  $P_1$  and  $P_2$  lie on the locus of (7), we have

$$(8) \quad 9 - 3E + F = 0$$

and

$$(9) \quad 16 + 4D + F = 0.$$

The center of (7) is  $(-\frac{D}{2}, -\frac{E}{2})$ , and since it lies on the given line,

$$-\frac{D}{2} + 2\left(-\frac{E}{2}\right) = 0,$$

or

$$(10) \quad D + 2E = 0.$$

Third step. Solving (8), (9), and (10), we obtain

$$D = -\frac{14}{5}, E = \frac{7}{5}, \text{ and } F = -\frac{24}{5}.$$

Fourth step. Substituting in (7), we obtain the required equation,

$$x^2 + y^2 - \frac{14}{5}x + \frac{7}{5}y - \frac{24}{5} = 0,$$

or

$$5x^2 + 5y^2 - 14x + 7y - 24 = 0.$$

The center is the point  $(\frac{7}{5}, -\frac{7}{10})$ , and the radius is  $\frac{1}{2}\sqrt{29}$ .

## PROBLEMS

1. Find the equation of the circle whose center is

- |  |  |
|--|--|
| (a) $(0, 1)$ and whose radius is 3.              | <i>Ans.</i> $x^2 + y^2 - 2y - 8 = 0.$    |
| (b) $(-2, 0)$ and whose radius is 2.             | <i>Ans.</i> $x^2 + y^2 + 4x = 0.$        |
| (c) $(-3, 4)$ and whose radius is 5.             | <i>Ans.</i> $x^2 + y^2 + 6x - 8y = 0.$   |
| (e) $(\alpha, 0)$ and whose radius is $\alpha$ . | <i>Ans.</i> $x^2 + y^2 - 2\alpha x = 0.$ |
| (f) $(0, \beta)$ and whose radius is $\beta$ .   | <i>Ans.</i> $x^2 + y^2 - 2\beta y = 0.$  |
| (g) $(0, -\beta)$ and whose radius is $\beta$ .  | <i>Ans.</i> $x^2 + y^2 + 2\beta y = 0.$  |

\* The radius is easily obtained, since  $\sqrt{2}$  is the length of the diagonal of a square whose side is one unit. We may construct a line whose length is  $\sqrt{n}$  by describing a semicircle on a line whose length is  $n+1$  and erecting a perpendicular to the diameter one unit from the end. The length of that perpendicular will be  $\sqrt{n}$ .

2. Find the locus of the following equations.

(a)  $x^2 + y^2 - 6x - 16 = 0.$

(f)  $x^2 + y^2 - 6x + 4y - 5 = 0.$

(b)  $3x^2 + 3y^2 - 10x - 24y = 0.$

(g)  $(x + 1)^2 + (y - 2)^2 = 0.$

(c)  $x^2 + y^2 = 0.$

(h)  $7x^2 + 7y^2 - 4x - y = 3.$

(d)  $x^2 + y^2 - 8x - 6y + 25 = 0.$

(i)  $x^2 + y^2 + 2ax + 2by + a^2 + b^2 = 0.$

(e)  $x^2 + y^2 - 2x + 2y + 5 = 0.$

(j)  $x^2 + y^2 + 16x + 100 = 0.$

3. Find the equation of the circle which

(a) has the center (2, 3) and passes through (3, -2).

$$\text{Ans. } x^2 + y^2 - 4x - 6y - 13 = 0.$$

(b) passes through the points (0, 0), (8, 0), (0, -6).

$$\text{Ans. } x^2 + y^2 - 8x + 6y = 0.$$

(c) passes through the points (4, 0), (-2, 5), (0, -3).

$$\text{Ans. } 19x^2 + 19y^2 + 2x - 47y - 312 = 0.$$

(d) passes through the points (3, 5) and (-3, 7) and has its center on the  $X$ -axis.

$$\text{Ans. } x^2 + y^2 + 4x - 46 = 0.$$

(e) passes through the points (4, 2) and (-6, -2) and has its center on the  $Y$ -axis.

$$\text{Ans. } x^2 + y^2 + 5y - 30 = 0.$$

(f) passes through the points (5, -3) and (0, 6) and has its center on the line  $2x - 3y - 6 = 0.$

$$\text{Ans. } 3x^2 + 3y^2 - 114x - 64y + 276 = 0.$$

(g) has the center (-1, -5) and is tangent to the  $X$ -axis.

$$\text{Ans. } x^2 + y^2 + 2x + 10y + 1 = 0.$$

(h) passes through (1, 0) and (5, 0) and is tangent to the  $Y$ -axis.

$$\text{Ans. } x^2 + y^2 - 6x \pm 2\sqrt{5}y + 5 = 0.$$

(i) passes through (0, 1), (5, 1), (2, -3).

$$\text{Ans. } 2x^2 + 2y^2 - 10x + y - 3 = 0.$$

(j) has the line joining (3, 2) and (-7, 4) as a diameter.

$$\text{Ans. } x^2 + y^2 + 4x - 6y - 13 = 0.$$

(k) has the line joining (3, -4) and (2, -5) as a diameter.

$$\text{Ans. } x^2 + y^2 - 5x + 9y + 26 = 0.$$

(l) which circumscribes the triangle formed by  $x - 6 = 0$ ,  $x + 2y = 0$ , and  $x - 2y = 8.$

$$\text{Ans. } 2x^2 + 2y^2 - 21x + 8y + 60 = 0.$$

(m) passes through the points (1, -2), (-2, 4), (3, -6). Interpret the result by the Corollary, p. 89.

(n) is inscribed in the triangle formed by  $4x + 3y - 12 = 0$ ,  $y - 2 = 0$ ,  $x - 10 = 0.$

$$\text{Ans. } 36x^2 + 36y^2 - 516x + 60y + 1585 = 0.$$

4. Plot the locus of  $x^2 + y^2 - 2x + 4y + k = 0$  for  $k = 0, 2, 4, 5 - 2, -4, -8.$  What values of  $k$  must be excluded?

$$\text{Ans. } k > 5.$$

5. What is the locus of  $x^2 + y^2 + Dx + Ey + F = 0$  if  $D$  and  $E$  are fixed and  $F$  varies?

6. For what values of  $k$  does the equation  $x^2 + y^2 - 4x + 2ky + 10 = 0$  have a locus?  
*Ans.*  $k > +\sqrt{6}$  and  $k < -\sqrt{6}$ .

7. For what values of  $k$  does the equation  $x^2 + y^2 + kx + F = 0$  have a locus when (a)  $F$  is positive; (b)  $F$  is zero; (c)  $F$  is negative?

*Ans.* (a)  $k > 2\sqrt{F}$  and  $k < -2\sqrt{F}$ ; (b) and (c) all values of  $k$ .

8. Find the number of point-circles represented by the equation in problem 7.  
*Ans.* (a) two; (b) one; (c) none.

9. Find the equation of the circle in oblique coördinates if  $\omega$  is the angle between the axes of coördinates.

*Ans.*  $(x - \alpha)^2 + (y - \beta)^2 + 2(x - \alpha)(y - \beta) \cos \omega = r^2$ .

10. Write an equation representing all circles with the radius 5 whose centers lie on the  $X$ -axis; on the  $Y$ -axis.

11. Find the number of values of  $k$  for which the locus of

$$(a) \quad x^2 + y^2 + 4kx - 2y + 5k = 0,$$

$$(b) \quad x^2 + y^2 + 4kx - 2y - k = 0,$$

$$(c) \quad x^2 + y^2 + 4kx - 2y + 4k = 0$$

is a point-circle.

*Ans.* (a) two; (b) none; (c) one.

12. Plot the circles  $x^2 + y^2 + 4x - 9 = 0$ ,  $x^2 + y^2 - 4x - 9 = 0$ , and  $x^2 + y^2 + 4x - 9 + k(x^2 + y^2 - 4x - 9) = 0$  for  $k = \pm 1, \pm 3, \pm \frac{1}{3}, -5, -\frac{1}{5}$ . Must any values of  $k$  be excluded?

13. Plot the circles  $x^2 + y^2 + 4x = 0$ ,  $x^2 + y^2 - 4x = 0$ , and  $x^2 + y^2 + 4x + k(x^2 + y^2 - 4x) = 0$  for the values of  $k$  in problem 12. Must any values of  $k$  be excluded?

14. Plot the circles  $x^2 + y^2 + 4x + 9 = 0$ ,  $x^2 + y^2 - 4x + 9 = 0$ , and  $x^2 + y^2 + 4x + 9 + k(x^2 + y^2 - 4x + 9) = 0$  for  $k = -3, -\frac{1}{3}, -5, -\frac{1}{5}, -\frac{7}{3}, -\frac{3}{7}, -1$ . What values of  $k$  must be excluded?

54. **Systems of circles.** An equation of the form

$$x^2 + y^2 + Dx + Ey + F = 0$$

will define a **system of circles** if one or more of the coefficients contain an arbitrary constant. Thus the equation

$$x^2 + y^2 - r^2 = 0$$

represents the system of concentric circles whose centers are at the origin. Very interesting systems of circles, and the only systems we shall consider, are represented by equations analogous to (XIII), p. 110.

**Theorem II.** *Given two circles,*

$$C_1: x^2 + y^2 + D_1x + E_1y + F_1 = 0$$

and

$$C_2: x^2 + y^2 + D_2x + E_2y + F_2 = 0;$$

then the locus of the equation

$$(II) \quad x^2 + y^2 + D_1x + E_1y + F_1 \\ + k(x^2 + y^2 + D_2x + E_2y + F_2) = 0$$

is a circle except when  $k = -1$ . In this case the locus is a straight line.

*Proof.* Clearing the parenthesis in (II) and collecting like terms in  $x$  and  $y$ , we obtain

$$(1+k)x^2 + (1+k)y^2 + (D_1 + kD_2)x + (E_1 + kE_2)y + (F_1 + kF_2) = 0.$$

Dividing by  $1+k$  we have

$$x^2 + y^2 + \frac{D_1 + kD_2}{1+k}x + \frac{E_1 + kE_2}{1+k}y + \frac{F_1 + kF_2}{1+k} = 0.$$

The locus of this equation is a circle (Theorem I, p. 116). If, however,  $k = -1$ , we cannot divide by  $1+k$ . But in this case equation (II) becomes

$$(D_1 - D_2)x + (E_1 - E_2)y + (F_1 - F_2) = 0,$$

which is of the first degree in  $x$  and  $y$ . Its locus is then a straight line called the **radical axis** of  $C_1$  and  $C_2$ . Q.E.D.

**Corollary I.** *The center of the circle (II) lies upon the line joining the centers of  $C_1$  and  $C_2$  and divides that line into segments whose ratio is equal to  $k$ .*

For by Theorem I (p. 116) the center of  $C_1$  is  $P_1\left(-\frac{D_1}{2}, -\frac{E_1}{2}\right)$  and of  $C_2$  is  $P_2\left(-\frac{D_2}{2}, -\frac{E_2}{2}\right)$ . The point dividing  $P_1P_2$  into segments whose ratio equals  $k$  is (Theorem VII, p. 32) the point  $\left[\frac{-\frac{D_1}{2} + k\left(-\frac{D_2}{2}\right)}{1+k}, \frac{-\frac{E_1}{2} + k\left(-\frac{E_2}{2}\right)}{1+k}\right]$ , or, simplifying,  $\left(-\frac{D_1 + kD_2}{2(1+k)}, -\frac{E_1 + kE_2}{2(1+k)}\right)$ , which is the center of (II).

**Corollary II.** *The equation of the radical axis of  $C_1$  and  $C_2$  is*

$$(D_1 - D_2)x + (E_1 - E_2)y + (F_1 - F_2) = 0.$$

**Corollary III.** *The radical axis of two circles is perpendicular to the line joining their centers.*

*Hint.* Find the line joining the centers of  $C_1$  and  $C_2$  (Theorem VII, p. 88) and show that it is perpendicular to the radical axis by Corollary III, p. 78.

The system (II) may have three distinct forms, as illustrated in the following examples. These three forms correspond to the relative positions of  $C_1$  and  $C_2$ , which may intersect in two points, be tangent to each other, or not meet at all.

**Ex. 1.** Plot the system of circles represented by

$$x^2 + y^2 + 8x - 9 + k(x^2 + y^2 - 4x - 9) = 0.$$

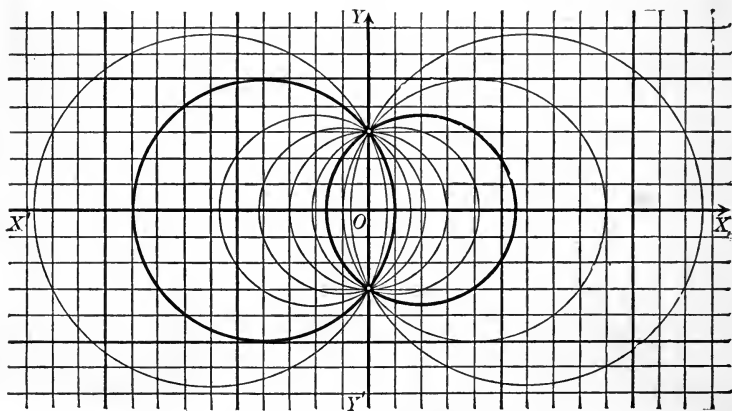

*Solution.* The figure shows the circles

$$x^2 + y^2 + 8x - 9 = 0 \text{ and } x^2 + y^2 - 4x - 9 = 0$$

plotted in heavy lines and the circles corresponding to

$$k = 2, 5, 1, \frac{1}{2}, -4, -\frac{5}{2}, \text{ and } -\frac{1}{4};$$

these circles all pass through the intersection of the first two.

The radical axis of the two circles plotted in heavy lines, which corresponds to  $k = -1$ , is the  $Y$ -axis.

**Ex. 2.** Plot the system of circles represented by

$$x^2 + y^2 + 8x + k(x^2 + y^2 - 4x) = 0.$$

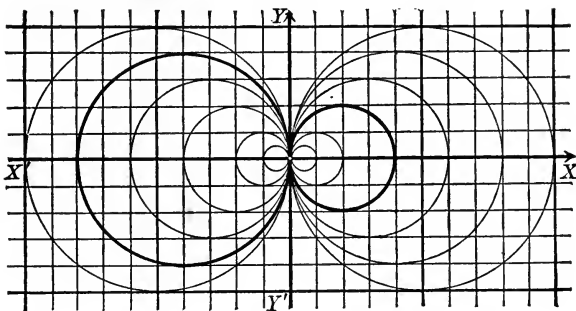

*Solution.* The figure shows the circles

$$x^2 + y^2 + 8x = 0 \text{ and } x^2 + y^2 - 4x = 0$$

plotted in heavy lines and the circles corresponding to

$$k = 2, 3, \frac{7}{3}, 5, 1, \frac{1}{2}, -7, \frac{1}{5}, -4, -3, \text{ and } -\frac{1}{7}.$$

These circles are all tangent to the given circles at their point of tangency. The locus for  $k = 2$  is the origin.

**Ex. 3.** Plot the system of circles represented by

$$x^2 + y^2 - 10x + 9 + k(x^2 + y^2 + 8x + 9) = 0.$$

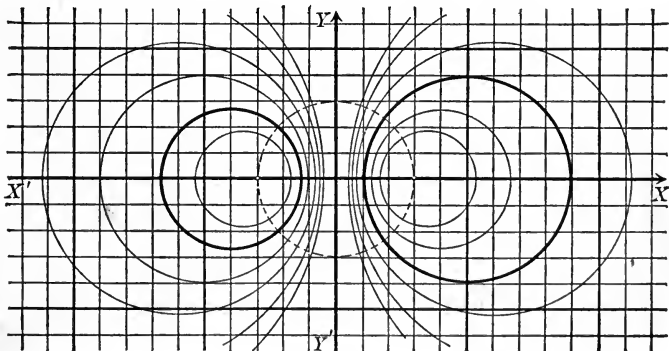

*Solution.* The figure shows the circles

$$x^2 + y^2 - 10x + 9 = 0 \text{ and } x^2 + y^2 + 8x + 9 = 0$$

plotted in heavy lines and the circles corresponding to

$$k = \frac{1}{3}, 17, \frac{1}{3}, -10, -\frac{1}{10}, \text{ and } -\frac{1}{2}.$$

These circles all cut the dotted circle at right angles (problem 7). For  $k = \frac{7}{2}$  the locus is the point-circle  $(3, 0)$ , and for  $k = 8$  it is the point-circle  $(-3, 0)$ .

In all three examples the radical axis, for which  $k = -1$ , is the  $Y$ -axis.

### PROBLEMS

1. If  $C_1$  and  $C_2$  intersect in  $P_1$  and  $P_2$ , the system (II) consists of all circles passing through  $P_1$  and  $P_2$ .

2. If  $C_1$  and  $C_2$  are tangent, the system (II) consists of all circles tangent to  $C_1$  and  $C_2$  at their point of tangency.

3. The radical axis of two intersecting circles is their common chord, and of two tangent circles is the common tangent at their point of tangency.

4. Find the equation of the circle passing through the intersections of the circles  $x^2 + y^2 - 1 = 0$  and  $x^2 + y^2 + 2x = 0$  which passes through the point  $(3, 2)$ .

$$\text{Ans. } 7x^2 + 7y^2 - 24x - 19 = 0.$$

5. Two circles  $x^2 + y^2 + D_1x + E_1y + F_1 = 0$  and  $x^2 + y^2 + D_2x + E_2y + F_2 = 0$  intersect at right angles when and only when  $D_1D_2 + E_1E_2 - 2F_1 - 2F_2 = 0$ .

*Hint.* Construct a triangle by drawing the line of centers and the radii to a point of intersection  $P_1$ .

6. The equation of the system (II) may be written in the form  $x^2 + y^2 + kx + F = 0$ , where  $F$  is constant and  $k$  arbitrary, if the axes of  $x$  and  $y$  be respectively chosen as the line of centers and the radical axis of  $C_1$  and  $C_2$ .

7. The system in problem 6 consists of all circles whose intercepts on the  $Y$ -axis are  $\pm\sqrt{-F}$  if  $F < 0$ , which are tangent to the  $Y$ -axis at the origin if  $F = 0$ , and which intersect the circle  $x^2 + y^2 = F$  at right angles if  $F > 0$ .

8. The square of the length of the tangent from  $P_1(x_1, y_1)$  to the circle  $x^2 + y^2 + Dx + Ey + F = 0$  is  $x_1^2 + y_1^2 + Dx_1 + Ey_1 + F$ .

*Hint.* Construct a right triangle by joining  $P_1$  and the point of tangency to the center.

9. The locus of points from which tangents to two circles are equal is their radical axis.

10. Find the radical axes of the circles  $x^2 + y^2 - 4x = 0$ ,  $x^2 + y^2 + 6x - 8y = 0$ , and  $x^2 + y^2 + 6x - 8 = 0$  taken by pairs, and show that they meet in a point.

11. Show that the radical axes of any three circles taken by pairs meet in a point.

12. By means of problem 11 show that a circle may be drawn cutting any three circles at right angles.

13. Show that the radical axis of any pair of circles in the system (II) is the same as the radical axis of  $C_1$  and  $C_2$ .

14. How may problem 11 be stated if the three circles are point-circles?



## CHAPTER VI

### POLAR COÖRDINATES

**55. Polar coördinates.** In this chapter we shall consider a second method of determining points of the plane by pairs of real numbers. We suppose given a fixed point  $O$ , called the **pole**, and a fixed line  $OA$ , passing through  $O$ , called the **polar axis**. Then any point  $P$  determines a length  $OP = \rho$  and an angle  $AOP = \theta$ . The numbers  $\rho$  and  $\theta$  are called the **polar coördinates** of  $P$ .  $\rho$  is called the **radius vector** and  $\theta$  the **vectorial angle**. The vectorial angle  $\theta$  is *positive* or *negative* as in Trigonometry (p. 11). The radius vector is *positive* if  $P$  lies on the terminal line of  $\theta$ , and *negative* if  $P$  lies on that line produced through the pole  $O$ .

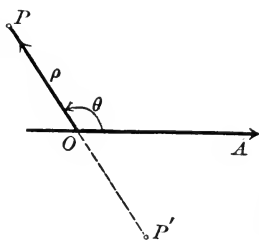

Thus in the figure the radius vector of  $P$  is positive, and that of  $P'$  is negative.

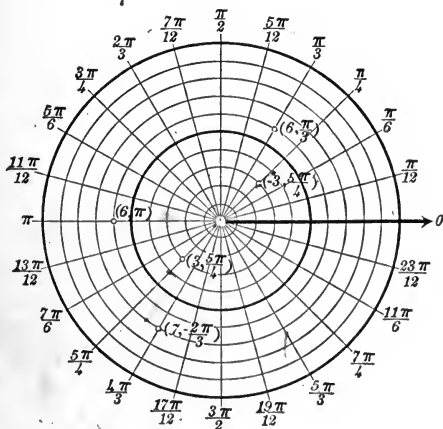

It is evident that *every pair of real numbers*  $(\rho, \theta)$  *determines a single point*, which may be plotted by the

**Rule for plotting a point whose polar coördinates  $(\rho, \theta)$  are given.**

*First step.* Construct the terminal line of the vectorial angle  $\theta$ , as in Trigonometry.

*Second step.* If the radius vector is *positive*, lay off a length  $OP = \rho$  on the terminal line of  $\theta$ ; if *negative*, produce the

terminal line through the pole and lay off  $OP$  equal to the numerical value of  $\rho$ . Then  $P$  is the required point.

In the figure on p. 125 are plotted the points whose polar coordinates are  $(6, \frac{\pi}{3})$ ,  $(3, \frac{5\pi}{4})$ ,  $(-3, \frac{5\pi}{4})$ ,  $(6, \pi)$ , and  $(7, -\frac{2\pi}{3})$ .

Every point  $P$  determines an infinite number of pairs of numbers  $(\rho, \theta)$ .

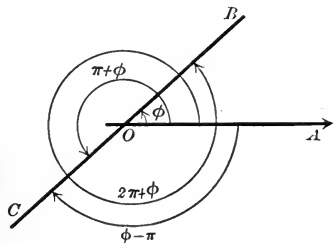

The values of  $\theta$  will differ by some multiple of  $\pi$ , so that if  $\phi$  is one value of  $\theta$  the others will be of the form  $\phi + k\pi$ , where  $k$  is a positive or negative integer. The values of  $\rho$  will be the same numerically, but will be positive or negative, if  $P$  lies on  $OB$ ; according as the value of  $\theta$  is chosen so that  $OB$  or  $OC$  is the terminal line. Thus, if  $OB = \rho$  the coordinates of  $B$  may be written in any one of the forms  $(\rho, \phi)$ ,  $(-\rho, \pi + \phi)$ ,  $(\rho, 2\pi + \phi)$ ,  $(-\rho, \phi - \pi)$ , etc.

Unless the contrary is stated, we shall always suppose that  $\theta$  is positive, or zero, and less than  $2\pi$ ; that is,  $0 \leq \theta < 2\pi$ .

#### PROBLEMS

- Plot the points  $(4, \frac{\pi}{4})$ ,  $(6, \frac{2\pi}{3})$ ,  $(-2, \frac{2\pi}{3})$ ,  $(4, \frac{\pi}{3})$ ,  $(-4, \frac{4\pi}{3})$ ,  $(5, \pi)$ .
- Plot the points  $(6, \pm \frac{\pi}{4})$ ,  $(-2, \pm \frac{\pi}{2})$ ,  $(3, \pi)$ ,  $(-4, \pi)$ ,  $(6, 0)$ ,  $(-6, 0)$ .
- Show that the points  $(\rho, \theta)$  and  $(\rho, -\theta)$  are symmetrical with respect to the polar axis.
- Show that the points  $(\rho, \theta)$ ,  $(-\rho, \theta)$  are symmetrical with respect to the pole.
- Show that the points  $(-\rho, \pi - \theta)$  and  $(\rho, \theta)$  are symmetrical with respect to the polar axis.

**56. Locus of an equation.** If we are given an equation in the variables  $\rho$  and  $\theta$ , then the locus of the equation (p. 52) is a curve such that:

- Every point whose coordinates  $(\rho, \theta)$  satisfy the equation lies on the curve.
- The coordinates of every point on the curve satisfy the equation.

The curve may be plotted by solving the equation for  $\rho$  and finding the values of  $\rho$  for particular values of  $\theta$  until the coördinates of enough points are obtained to determine the form of the curve.

The plotting is facilitated by the use of polar coördinate paper, which enables us to plot values of  $\theta$  by lines drawn through the pole and values of  $\rho$  by circles having the pole as center. The tables on p. 14 are to be used in constructing tables of values of  $\rho$  and  $\theta$ .

In *discussing* the locus of an equation the following points should be noticed.

1. The *intercepts on the polar axis* are obtained by setting  $\theta = 0$  and  $\theta = \pi$  and solving for  $\rho$ .

But other values of  $\theta$  may make  $\rho = 0$  and hence give a point on the polar axis, namely, the pole.

2. The *curve is symmetrical with respect to the pole* if, when  $-\rho$  is substituted for  $\rho$ , only the form of the equation is changed.

3. The *curve is symmetrical with respect to the polar axis* if, when  $-\theta$  is substituted for  $\theta$ , only the form of the equation is changed.

4. The *directions from the pole in which the curve recedes to infinity*, if any, are found by obtaining those values of  $\theta$  for which  $\rho$  becomes infinite.

5. The method of finding the *values of  $\theta$  which must be excluded*, if any, depends on the given equation.

**Ex. 1.** Discuss and plot the locus of the equation  $\rho = 10 \cos \theta$ .

*Solution.* The discussion enables us to simplify the plotting and is therefore put first.

1. For  $\theta = 0$   $\rho = 10$ , and for  $\theta = \pi$   $\rho = -10$ . Hence the curve crosses the polar axis 10 units to the right of the pole.

2. The curve is symmetrical with respect to the polar axis, for  $\cos(-\theta) = \cos \theta$  (4, p. 12).

$\theta$	$\rho$	$\theta$	$\rho$
0	10	$\frac{\pi}{2}$	0
$\frac{\pi}{12}$	9.7	$\frac{7\pi}{12}$	- 2.6
$\frac{\pi}{6}$	8.7	$\frac{2\pi}{3}$	- 5
$\frac{\pi}{4}$	7	$\frac{3\pi}{4}$	- 7
$\frac{\pi}{3}$	5	$\frac{5\pi}{6}$	- 8.7
$\frac{5\pi}{12}$	2.6	$\frac{11\pi}{12}$	- 9.7
		$\pi$	- 10

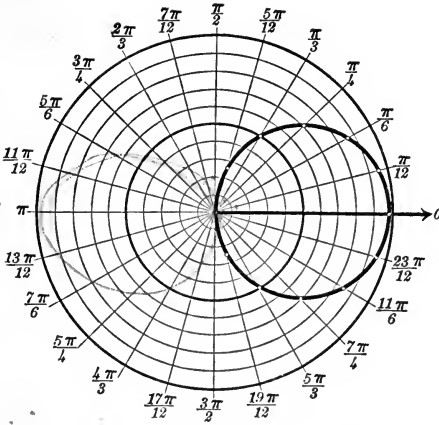

3. As  $\cos \theta$  is never infinite, the curve does not recede to infinity. Hence the curve is a closed curve.

4. No values of  $\theta$  make  $\rho$  imaginary.

Computing a table of values we obtain the table on p. 127.

As the curve is symmetrical with respect to the polar axis, the rest of the curve may be easily constructed without computing the table farther; but as the curve we have already constructed is symmetrical with respect to the polar axis,

no new points are obtained. The locus is a circle.

**Ex. 2.** Discuss and plot the locus of the equation  $\rho^2 = a^2 \cos 2\theta$ .

*Solution.* The discussion gives us the following properties.

1. For  $\theta = 0$  or  $\pi$   $\rho = \pm a$ . Hence the curve crosses the polar axis  $a$  units to the right and left of the pole.

2. The curve is symmetrical with respect to the pole.

3. It is also symmetrical with respect to the polar axis, for  $\cos(-2\theta) = \cos 2\theta$  (4, p. 12).

4.  $\rho$  does not become infinite.

5.  $\rho$  is imaginary when  $\cos 2\theta$  is negative.  $\cos 2\theta$  is negative when  $2\theta$  is in

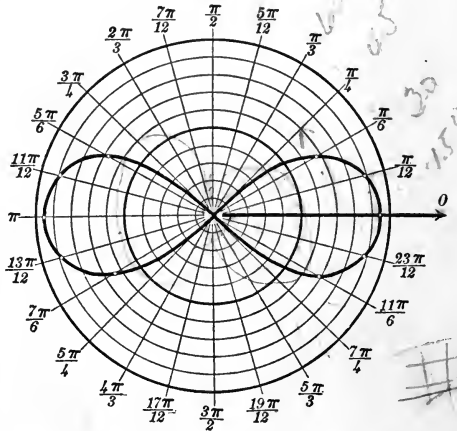

$\theta$	$\rho$	$\theta$	$\rho$
0	$\pm a$	$\frac{\pi}{6}$	$\pm .7a$
$\frac{\pi}{12}$	$\pm .93a$	$\frac{\pi}{4}$	0

the second or third quadrant; that is, when

$$\frac{3\pi}{2} > 2\theta > \frac{\pi}{2} \text{ or } \frac{7\pi}{2} > 2\theta > \frac{5\pi}{2}$$

Hence we must exclude values of  $\theta$  such that

$$\frac{3\pi}{4} > \theta > \frac{\pi}{4} \text{ and } \frac{7\pi}{4} > \theta > \frac{5\pi}{4}$$

The accompanying table of values is all that need be computed when we take account of 2, 3, and 5.

The complete curve is obtained by plotting these points and the points symmetrical to them with respect to the polar axis. The curve is called a **lemniscate**. In the figure  $a$  is taken equal to 9.5.

**Ex. 3.** Discuss and plot the locus of the equation

$$\rho = \frac{2}{1 + \cos \theta}.$$

*Solution.* 1. For  $\theta = 0$   $\rho = 1$ , and for  $\theta = \pi$   $\rho = \infty$ ; so the curve crosses the polar axis one unit to the right of the pole.

2. The curve is not symmetrical with respect to the pole. How may this be inferred from 1?

3. The curve is symmetrical with respect to the polar axis, since  $\cos(-\theta) = \cos \theta$  (4, p. 12).

4.  $\rho$  becomes infinite when  $1 + \cos \theta = 0$  or  $\cos \theta = -1$  and hence  $\theta = \pi$ . The curve recedes to infinity in but one direction.

5.  $\rho$  is never imaginary.

On account of 3 the table of values is computed only to  $\theta = \pi$ , and the rest of the curve is obtained from the symmetry with respect to the polar axis. The locus is a parabola.

$\theta$	$\rho$	$\theta$	$\rho$
0	1	$\frac{7\pi}{12}$	2.7
$\frac{\pi}{12}$	1.02	$\frac{2\pi}{3}$	4
$\frac{\pi}{6}$	1.07	$\frac{3\pi}{4}$	6.7
$\frac{\pi}{4}$	1.2	$\frac{5\pi}{6}$	14
$\frac{\pi}{3}$	1.3	$\frac{11\pi}{12}$	50
$\frac{5\pi}{12}$	1.6	$\pi$	$\infty$
$\frac{\pi}{2}$	2		

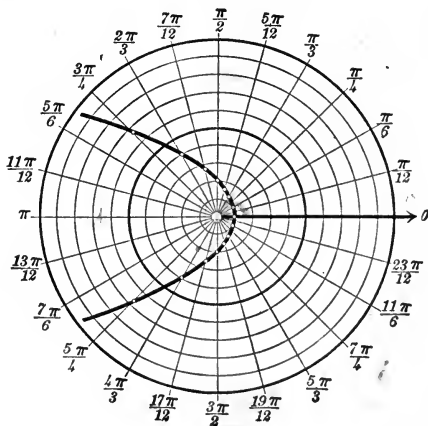

### PROBLEMS

Discuss and plot the loci of the following equations.

1.  $\rho = 10$ .  $\theta = \tan^{-1} 1$ .

5.  $\rho \sin \theta = 4$ .

2.  $\rho = 5$ .  $\theta = \frac{5\pi}{6}$ .

6.  $\rho = \frac{4}{1 - \cos \theta}$ .

3.  $\rho = 16 \cos \theta$ .

7.  $\rho = \frac{8}{2 - \cos \theta}$ .

4.  $\rho \cos \theta = 6$ .

$$8. \rho = \frac{8}{1 - 2 \cos \theta}$$

$$9. \rho = a \sin \theta.$$

$$10. \rho = a(1 - \cos \theta).$$

$$11. \rho^2 \sin 2\theta = 16.$$

$$12. \rho^2 = 16 \sin 2\theta.$$

$$13. \rho^2 \cos^2 2\theta = a^2.$$

$$14. \rho = a \sin 2\theta. \quad \rho = a \cos 2\theta.$$

$$15. \rho = \frac{8}{1 - e \cos \theta}$$

for  $e = 1, 2, \frac{1}{2}$ .

$$16. \rho \cos \theta = a \sin^2 \theta.$$

$$17. \rho \cos \theta = a \cos 2\theta.$$

$$18. \rho = a(4 + b \cos \theta)$$

for  $b = 3, 4, 6$ .

$$19. \rho = \frac{10}{1 + \tan \theta}.$$

$$20. \rho = a \sec \theta \pm b$$

for  $a > b, a = b, a < b$ .

$$21. \rho = a\theta.$$

$$22. \rho = a \sin 3\theta. \quad \rho = a \cos 3\theta.$$

23. Prove that the locus of an equation is symmetrical with respect to  $\theta = \frac{\pi}{2}$  if the results of substituting  $\frac{\pi}{2} + \theta$  and  $\frac{\pi}{2} - \theta$  give equations which differ only in form.

24. Apply the test for symmetry in problem 23 to the loci of 4, 5, 10, 11, and 12.

### 57. Transformation from rectangular to polar coördinates.

Let  $OX$  and  $OY$  be the axes of a rectangular system of coördinates, and let  $O$  be the pole and  $OX$  the polar axis of a system of polar coördinates. Let  $(x, y)$  and  $(\rho, \theta)$  be respectively the rectangular and polar coördinates of any point  $P$ . It is necessary

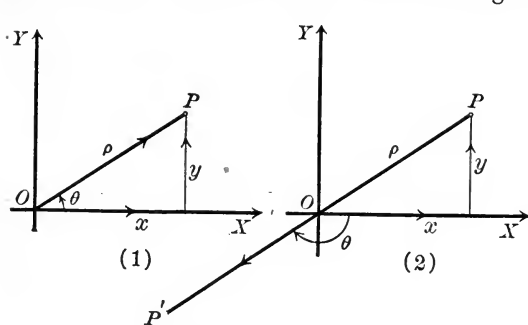

to distinguish two cases according as  $\rho$  is positive or negative. When  $\rho$  is *positive* (Fig. 1) we have, by definition,

$$\cos \theta = \frac{x}{\rho}, \quad \sin \theta = \frac{y}{\rho},$$

whatever quadrant  $P$  is in.

Hence

$$(1) \quad x = \rho \cos \theta, \quad y = \rho \sin \theta.$$

When  $\rho$  is *negative* (Fig. 2) we consider the point  $P'$  symmetrical to  $P$  with respect to  $O$ , whose rectangular and polar coördinates are respectively  $(-x, -y)$  and  $(-\rho, \theta)$ . The radius vector of  $P'$ ,  $-\rho$ , is positive since  $\rho$  is negative, and we can therefore use equations (1). Hence for  $P'$

$$-x = -\rho \cos \theta, \quad -y = -\rho \sin \theta;$$

and hence for  $P$

$$x = \rho \cos \theta, \quad y = \rho \sin \theta,$$

as before.

Hence we have

**Theorem I.** *If the pole coincides with the origin and the polar axis with the positive X-axis, then*

$$(I) \quad \begin{cases} x = \rho \cos \theta, \\ y = \rho \sin \theta, \end{cases}$$

where  $(x, y)$  are the rectangular coördinates and  $(\rho, \theta)$  the polar coördinates of any point.

Equations I are called the **equations of transformation** from rectangular to polar coördinates. They express the rectangular coördinates of any point in terms of the polar coördinates of that point and enable us to find the equation of a curve in polar coördinates when its equation in rectangular coördinates is known, and *vice versa*.

From the figures we also have

$$(2) \quad \begin{cases} \rho^2 = x^2 + y^2, & \theta = \tan^{-1} \frac{y}{x}, \\ \sin \theta = \frac{y}{\pm \sqrt{x^2 + y^2}}, & \cos \theta = \frac{x}{\pm \sqrt{x^2 + y^2}}. \end{cases}$$

These equations express the polar coördinates of any point in terms of the rectangular coördinates. They are not as convenient for use as (I), although the first one is at times very convenient.

**Ex. 1.** Find the equation of the circle  $x^2 + y^2 = 25$  in polar coördinates.

*Solution.* Substitute the values of  $x$  and  $y$  given by (I). This gives  $\rho^2 \cos^2 \theta + \rho^2 \sin^2 \theta = 25$ , or (by 3, p. 12)  $\rho^2 = 25$ ; and hence  $\rho = \pm 5$ , which is the required equation. It expresses the fact that the point  $(\rho, \theta)$  is five units from the origin.

**Ex. 2.** Find the equation of the lemniscate (Ex. 2, p. 128)  $\rho^2 = a^2 \cos 2\theta$  in rectangular coördinates.

*Solution.* By 14, p. 13, we have

$$\rho^2 = a^2(\cos^2 \theta - \sin^2 \theta).$$

Multiplying by  $\rho^2$ ,  $\rho^4 = a^2(\rho^2 \cos^2 \theta - \rho^2 \sin^2 \theta).$

From (2) and (I),  $(x^2 + y^2)^2 = a^2(x^2 - y^2).$  *Ans.*

### 58. Applications.

**Theorem II.** *The general equation of the straight line in polar coördinates is*

$$(II) \quad \rho(A \cos \theta + B \sin \theta) + C = 0,$$

where  $A$ ,  $B$ , and  $C$  are arbitrary constants.

*Proof.* The general equation of the line in rectangular coördinates is (Theorem II, p. 77)

$$Ax + By + C = 0.$$

By substitution from (I) we obtain (II).

Q. E. D.

When  $A = 0$  the line is parallel to the polar axis, when  $B = 0$  it is perpendicular to the polar axis, and when  $C = 0$  it passes through the pole.

In like manner we obtain

**Theorem III.** *The general equation of the circle in polar coördinates is*

$$(III) \quad \rho^2 + \rho(D \cos \theta + E \sin \theta) + F = 0,$$

where  $D$ ,  $E$ , and  $F$  are arbitrary constants.

**Corollary.** *If the pole is on the circumference and the polar axis passes through the center, the equation is*

$$\rho - 2r \cos \theta = 0,$$

where  $r$  is the radius of the circle.

For if the center lies on the polar axis, or  $X$ -axis,  $E = 0$  (Corollary, p. 116); and if the circle passes through the pole, or origin,  $F = 0$ . The abscissa of the center equals the radius, and hence (Theorem I, p. 116)  $-\frac{1}{2}D = r$ , or  $D = -2r$ . Substituting these values of  $D$ ,  $E$ , and  $F$  in (III) gives  $\rho - 2r \cos \theta = 0$ .

**Theorem IV.** *The length  $l$  of the line joining two points  $P_1(\rho_1, \theta_1)$  and  $P_2(\rho_2, \theta_2)$  is given by*

$$(IV) \quad l^2 = \rho_1^2 + \rho_2^2 - 2\rho_1\rho_2 \cos(\theta_1 - \theta_2).$$



*Proof.* Let the rectangular coördinates of  $P_1$  and  $P_2$  be respectively  $(x_1, y_1)$  and  $(x_2, y_2)$ . Then by Theorem I, p. 131,

$$x_1 = \rho_1 \cos \theta_1, \quad x_2 = \rho_2 \cos \theta_2,$$

$$y_1 = \rho_1 \sin \theta_1, \quad y_2 = \rho_2 \sin \theta_2.$$

By Theorem IV, p. 24,

$$l^2 = (x_1 - x_2)^2 + (y_1 - y_2)^2,$$

and hence  $l^2 = (\rho_1 \cos \theta_1 - \rho_2 \cos \theta_2)^2 + (\rho_1 \sin \theta_1 - \rho_2 \sin \theta_2)^2$ .

Removing parentheses and using 3, p. 12, and 11, p. 13, we obtain (IV). Q.E.D.

### PROBLEMS

1. Transform the following equations into polar coördinates and plot their loci.

(a)  $x - 3y = 0$ .

*Ans.*  $\theta = \tan^{-1} \frac{1}{3}$ .

(b)  $y + 5 = 0$ .

*Ans.*  $\rho = \frac{-5}{\sin \theta}$ .

(c)  $x^2 + y^2 = 16$ .

*Ans.*  $\rho = \pm 4$ .

(d)  $x^2 + y^2 - ax = 0$ .

*Ans.*  $\rho = a \cos \theta$ .

(e)  $2xy = 7$ .

*Ans.*  $\rho^2 \sin 2\theta = 7$ .

(f)  $x^2 - y^2 = a^2$ .

*Ans.*  $\rho^2 \cos 2\theta = a^2$ .

(g)  $x \cos \omega + y \sin \omega - p = 0$ .

*Ans.*  $\rho \cos(\theta - \omega) - p = 0$ .

(h)  $(1 - e^2)x^2 + y^2 - 2e^2px - e^2p^2 = 0$ .

*Ans.*  $\rho = \frac{ep}{1 - e \cos \theta}$ .

(i)  $2xy + 4y^2 - 8x + 9 = 0$ . *Ans.*  $\rho^2(\sin 2\theta + 4 \sin^2 \theta) - 8\rho \cos \theta + 9 = 0$ .

2. Transform equations 1 to 21, p. 129, into rectangular coördinates.

3. Find the polar coördinates of the points  $(3, 4)$ ,  $(-4, 3)$ ,  $(5, -12)$ ,  $(4, 5)$ .

4. Find the rectangular coördinates of the points  $(5, \frac{\pi}{2})$ ,  $(-2, \frac{3\pi}{4})$ ,  $(3, \pi)$ .

5. Transform into rectangular coördinates  $\rho = \frac{ep}{1 - e \cos \theta}$ .

**59. Equation of a locus.** The equation of a locus may often be found with more ease in polar than in rectangular coördinates, especially if the locus is described by the end of a line of variable length revolving about a fixed point. The steps in the process of finding the polar equation of a locus correspond to those in the Rule on p. 46.

**Ex. 1.** Find the locus of the middle points of the chords of the circle  $C: \rho - 2r \cos \theta = 0$  which pass through the pole which is on the circle.

*Solution.* Let  $P(\rho, \theta)$  be any point on the locus. Then, by hypothesis,

$$OP = \frac{1}{2} OQ,$$

where  $Q$  is a point on  $C$ .

$$\text{But } OP = \rho \text{ and } OQ = 2r \cos \theta.$$

$$\text{Hence } \rho = r \cos \theta.$$

From the Corollary (p. 132) it is seen that the locus is a circle described on the radius of  $C$  through  $O$  as a diameter.

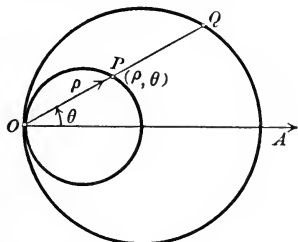

**Ex. 2.** The radius of a circle is prolonged a distance equal to the ordinate of its extremity. Find the locus of the end of this line.

*Solution.* Let  $r$  be the radius of the circle, let its center be the pole, and let  $P(\rho, \theta)$  be any point on the locus. Then, by hypothesis,

$$OP = OB + CB.$$

$$\text{But } OP = \rho,$$

$$OB = r,$$

$$\text{and } CB = r \sin \theta.$$

Hence the equation of the locus of  $P$  is

$$\rho = r + r \sin \theta.$$

The locus of this equation is called a cardioid.

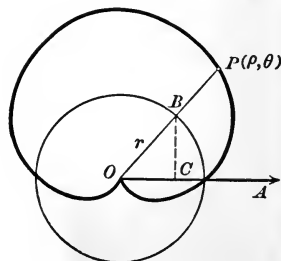

### PROBLEMS

1. Chords passing through a fixed point on a circle are extended their own lengths. Find the locus of their extremities.

*Ans.* A circle whose radius is a diameter of the given circle.

2. Chords of the circle  $\rho = 10 \cos \theta$  which pass through the pole are extended 10 units. Find the locus of the extremities of these lines.

$$\text{Ans. } \rho = 10(1 + \cos \theta).$$

3. Chords of the circle  $\rho = 2a \cos \theta$  which pass through the pole are extended a distance  $2b$ . Find the locus of their extremities.

$$\text{Ans. } \rho = 2(b + a \cos \theta).$$

4. Find the locus of the middle points of the lines drawn from a fixed point to a given circle.

*Hint.* Take the fixed point for the pole and let the polar axis pass through the center of the circle.

*Ans.* A circle whose radius is half that of the given circle and whose center is midway between the pole and the center of the given circle.

5. A line is drawn from a fixed point  $O$  meeting a fixed line in  $P_1$ . Find the locus of a point  $P$  on this line such that  $OP_1 \cdot OP = a^2$ . *Ans.* A circle.

6. A line is drawn through a fixed point  $O$  meeting a fixed circle in  $P_1$  and  $P_2$ . Find the locus of a point  $P$  on this line such that

$$OP = 2 \frac{OP_1 \cdot OP_2}{OP_1 + OP_2}. \quad \text{Ans. A straight line.}$$

## CHAPTER VII

### TRANSFORMATION OF COÖRDINATES

**60.** When we are at liberty to choose the axes as we please we generally choose them so that our results shall have the simplest possible form. When the axes are given it is important that we be able to find the equation of a given curve referred to some other axes. The operation of changing from one pair of axes to a second pair is known as a **transformation of coördinates**. We regard the axes as moved from their given position to a new position and we seek formulas which express the old coördinates in terms of the new coördinates.

**61. Translation of the axes.** If the axes be moved from a first position  $OX$  and  $OY$  to a second position  $O'X'$  and  $O'Y'$  such that  $O'X'$  and  $O'Y'$  are respectively parallel to  $OX$  and  $OY$ , then the axes are said to be **translated** from the first to the second position.

Let the new origin be  $O'(h, k)$  and let the coördinates of any point  $P$  before and after the translation be respectively  $(x, y)$  and  $(x', y')$ . Projecting  $OP$  and  $O'O'P$ , on  $OX$ , we obtain (Theorem XI, p. 41)

$$x = x' + h.$$

Similarly,  $y = y' + k.$

Hence,

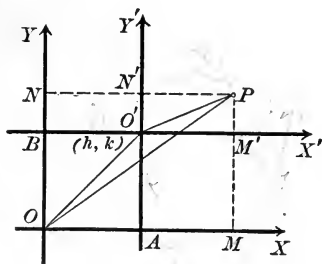

**Theorem I.** *If the axes be translated to a new origin  $(h, k)$ , and if  $(x, y)$  and  $(x', y')$  are respectively the coördinates of any point  $P$  before and after the translation, then*

$$(I) \quad \begin{cases} x = x' + h, \\ y = y' + k. \end{cases}$$

Equations (I) are called the equations for translating the axes. To find the equation of a curve referred to the new axes when its equation referred to the old axes is given, we substitute the values of  $x$  and  $y$  given by (I) in the given equation. For the given equation expresses the fact that  $P(x, y)$  lies on the given curve, and since equations (I) are true for *all* values of  $(x, y)$ , the new equation gives a relation between  $x'$  and  $y'$  which expresses that  $P(x', y')$  lies on the curve and is therefore (p. 46) the equation of the curve in the new coördinates.

**Ex. 1.** Transform the equation

$$x^2 + y^2 - 6x + 4y - 12 = 0$$

when the axes are translated to the new origin  $(3, -2)$ .

*Solution.* Here  $h = 3$  and  $k = -2$ , so equations (I) become

$$x = x' + 3, \quad y = y' - 2.$$

Substituting in the given equation, we obtain

$$(x' + 3)^2 + (y' - 2)^2 - 6(x' + 3) + 4(y' - 2) - 12 = 0,$$

or, reducing,  $x'^2 + y'^2 = 25$ .

This result could easily be foreseen. For the locus of the given equation is (Theorem I, p. 116) a circle whose center is  $(3, -2)$  and whose radius is 5. When the origin is translated to the center the equation of the circle must necessarily have the form obtained (Corollary, p. 51).

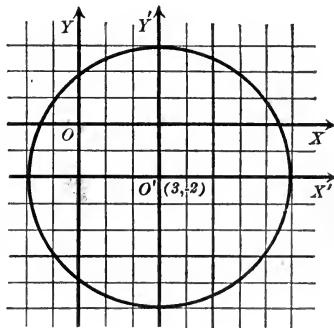

### PROBLEMS

1. Find the new coördinates of the points  $(3, -5)$  and  $(-4, 2)$  when the axes are translated to the new origin  $(3, 6)$ .

2. Transform the following equations when the axes are translated to the new origin indicated and plot both pairs of axes and the curve.

(a)  $3x - 4y = 6$ ,  $(2, 0)$ .      Ans.  $3x' - 4y' = 0$ .

(b)  $x^2 + y^2 - 4x - 2y = 0$ ,  $(2, 1)$ .      Ans.  $x'^2 + y'^2 = 5$ .

(c)  $y^2 - 6x + 9 = 0$ ,  $(\frac{3}{2}, 0)$ .      Ans.  $y'^2 = 6x'$ .

(d)  $x^2 + y^2 - 1 = 0$ ,  $(-3, -2)$ .      Ans.  $x'^2 + y'^2 - 6x' - 4y' + 12 = 0$ .

(e)  $y^2 - 2kx + k^2 = 0$ ,  $(\frac{k}{2}, 0)$ .      Ans.  $y'^2 = 2kx'$ .

(f)  $x^2 - 4y^2 + 8x + 24y - 20 = 0$ ,  $(-4, 3)$ .      Ans.  $x'^2 - 4y'^2 = 0$ .

3. Derive equations (I) if  $O'$  is in (a) the second quadrant; (b) the third quadrant; (c) the fourth quadrant.

**62. Rotation of the axes.** Let the axes  $OX$  and  $OY$  be rotated about  $O$  through an angle  $\theta$  to the positions  $OX'$  and  $OY'$ . The equations giving the coördinates of any point referred to  $OX$  and  $OY$  in terms of its coördinates referred to  $OX'$  and  $OY'$  are called the equations for rotating the axes.

**Theorem II.** *The equations for rotating the axes through an angle  $\theta$  are*

$$(II) \quad \begin{cases} x = x' \cos \theta - y' \sin \theta, \\ y = x' \sin \theta + y' \cos \theta. \end{cases}$$

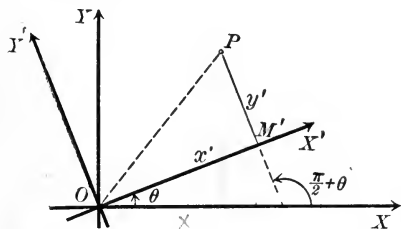

*Proof.* Let  $P$  be any point whose old and new coördinates are respectively  $(x, y)$  and  $(x', y')$ . Draw  $OP$  and

draw  $PM'$  perpendicular to  $OX'$ . Project  $OP$  and  $OM'P$  on  $OX$ .

The proj. of  $OP$  on  $OX = x$ . (Theorem III, p. 24)

The proj. of  $OM'$  on  $OX = x' \cos \theta$ . (Theorem II, p. 23)

The proj. of  $M'P$  on  $OX = y' \cos \left( \frac{\pi}{2} + \theta \right)$ . (Theorem II, p. 23)  
 $= -y' \sin \theta$ . (by 6, p. 13)

Hence (Theorem XI, p. 41)

$$x = x' \cos \theta - y' \sin \theta.$$

In like manner, projecting  $OP$  and  $OM'P$  on  $OY$ , we obtain

$$\begin{aligned} y &= x' \cos \left( \frac{\pi}{2} - \theta \right) + y' \cos \theta \\ &= x' \sin \theta + y' \cos \theta. \end{aligned}$$

Q. E. D.

If the equation of a curve in  $x$  and  $y$  is given, we substitute from (II) in order to find the equation of the same curve referred to  $OX'$  and  $OY'$ .

**Ex. 1.** Transform the equation  $x^2 - y^2 = 16$  when the axes are rotated through  $\frac{\pi}{4}$ .

*Solution.* Since

$$\sin \frac{\pi}{4} = \frac{1}{\sqrt{2}} = \frac{1}{\sqrt{2}}$$

and  $\cos \frac{\pi}{4} = \frac{1}{\sqrt{2}},$

equations (II) become

$$x = \frac{x' - y'}{\sqrt{2}}, \quad y = \frac{x' + y'}{\sqrt{2}}.$$

Substituting in the given equation, we obtain

$$\left(\frac{x' - y'}{\sqrt{2}}\right)^2 - \left(\frac{x' + y'}{\sqrt{2}}\right)^2 = 16,$$

or, simplifying,

$$x'y' + 8 = 0.$$

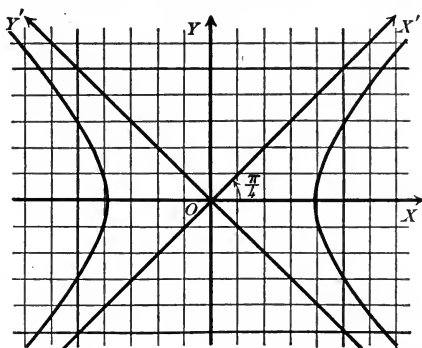

### PROBLEMS

1. Find the coördinates of the points  $(3, 1)$ ,  $(-2, 6)$ , and  $(4, -1)$  when the axes are rotated through  $\frac{\pi}{2}$ .

2. Transform the following equations when the axes are rotated through the indicated angle. Plot both pairs of axes and the curve.

(a)  $x - y = 0, \frac{\pi}{4}.$

*Ans.*  $y' = 0.$

(b)  $x^2 + 2xy + y^2 = 8, \frac{\pi}{4}.$

*Ans.*  $x'^2 = 4.$

(c)  $y^2 = 4x, -\frac{\pi}{2}.$

*Ans.*  $x'^2 = 4y'.$

(d)  $x^2 + 4xy + y^2 = 16, \frac{\pi}{4}.$

*Ans.*  $3x'^2 - y'^2 = 16.$

(e)  $x^2 + y^2 = r^2, \theta.$

*Ans.*  $x'^2 + y'^2 = r^2.$

(f)  $x^2 + 2xy + y^2 + 4x - 4y = 0, -\frac{\pi}{4}.$

*Ans.*  $\sqrt{2}y'^2 + 4x' = 0.$

3. Derive equations (II) if  $\theta$  is obtuse.

**63. General transformation of coördinates.** If the axes are moved in any manner, they may be brought from the old position to the new position by translating them to the new origin and then rotating them through the proper angle.

**Theorem III.** *If the axes be translated to a new origin  $(h, k)$  and then rotated through an angle  $\theta$ , the equations of the transformation of coördinates are*

$$(III) \quad \begin{cases} x = x' \cos \theta - y' \sin \theta + h, \\ y = x' \sin \theta + y' \cos \theta + k. \end{cases}$$

*Proof.* To translate the axes to  $O'X''$  and  $O'Y''$  we have, by (I),

$$x = x'' + h,$$

$$y = y'' + k,$$

where  $(x'', y'')$  are the coördinates of any point  $P$  referred to  $O'X''$  and  $O'Y''$ .

To rotate the axes we set, by (II),

$$x'' = x'' \cos \theta - y'' \sin \theta,$$

$$y'' = x'' \sin \theta + y'' \cos \theta.$$

Substituting these values of  $x''$  and  $y''$ , we obtain (III). Q.E.D.

**64. Classification of loci.** The loci of algebraic equations (p. 10) are classified according to the *degree* of the equations. This classification is justified by the following theorem, which shows that the degree of the equation of a locus is the same no matter how the axes are chosen.

**Theorem IV.** *The degree of the equation of a locus is unchanged by a transformation of coördinates.*

*Proof.* Since equations (III) are of the first degree in  $x'$  and  $y'$ , the degree of an equation cannot be *raised* when the values of  $x$  and  $y$  given by (III) are substituted. Neither can the degree be *lowered*; for then the degree must be raised if we transform back to the old axes, and we have seen that it cannot be raised by changing the axes.\*

As the degree can neither be raised nor lowered by a transformation of coördinates, it must remain unchanged. Q.E.D.

\* This also follows from the fact that when equations (III) are solved for  $x'$  and  $y'$  the results are of the first degree in  $x$  and  $y$ .

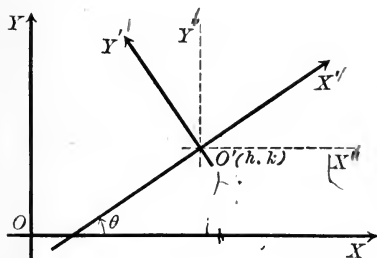



**65. Simplification of equations by transformation of coördinates.** The principal use made of transformation of coördinates is to discuss the various forms in which the equation of a curve may be put. In particular, they enable us to deduce *simple* forms to which an equation may be reduced.

*Rule to simplify the form of an equation.*

*First step.* Substitute the values of  $x$  and  $y$  given by (I) [or (II)] and collect like powers of  $x'$  and  $y'$ .

*Second step.* Set equal to zero the coefficients of two terms obtained in the first step which contain  $h$  and  $k$  (or one coefficient containing  $\theta$ ).

*Third step.* Solve the equations obtained in the second step for  $h$  and  $k^*$  (or  $\theta$ ).

*Fourth step.* Substitute these values for  $h$  and  $k$  (or  $\theta$ ) in the result of the first step. The result will be the required equation.

In many examples it is necessary to apply the rule twice in order to rotate the axes, and then translate them, or *vice versa*. It is usually simpler to do this than to employ equations (III) in the Rule and do both together. Just what coefficients are set equal to zero in the second step will depend on the object in view.

It is often convenient to drop the primes in the new equation and remember that the equation is referred to the new axes.

**Ex. 1.** Simplify the equation  $y^2 - 8x + 6y + 17 = 0$  by translating the axes.

*Solution.* First step. Set  $x = x' + h$  and  $y = y' + k$ .

This gives  $(y' + k)^2 - 8(x' + h) + 6(y' + k) + 17 = 0$ , or

$$(1) \quad \begin{array}{r|l} y'^2 - 8x' + 2k & y' + k^2 \\ + 6 & - 8h \\ & + 6k \\ & + 17 \end{array} \dagger = 0.$$

\* It may not be possible to solve these equations (Theorem IV, p. 81).

† These vortical bars play the part of parentheses. Thus  $2k + 6$  is the coefficient of  $y'$  and  $k^2 - 8h + 6k + 17$  is the constant term. Their use enables us to collect like powers of  $x'$  and  $y'$  at the same time that we remove the parentheses in the preceding equation.

Second step. Setting the coefficient of  $y'$  and the constant term, the only coefficients containing  $h$  and  $k$ , equal to zero, we obtain

$$(2) \quad 2k + 6 = 0,$$

$$(3) \quad k^2 - 8h + 6k + 17 = 0.$$

Third step. Solving (2) and (3) for  $h$  and  $k$ , we find

$$k = -3, \quad h = 1.$$

Fourth step. Substituting in (1), remembering that  $h$  and  $k$  satisfy (2) and (3), we have

$$y'^2 - 8x' = 0.$$

The locus is the parabola plotted in the figure which shows the new and old axes.

**Ex. 2.** Simplify  $x^2 + 4y^2 - 2x - 16y + 1 = 0$  by translating the axes.

*Solution.* First step. Set  $x = x' + h$ ,  $y = y' + k$ . This gives

$$(4) \quad \begin{array}{r} x^2 + 4y^2 + 2h \left| x' + 8k \right. \left. \begin{array}{l} y' + h^2 \\ + 4k^2 \\ - 2h \\ - 16k \\ + 1 \end{array} \right| = 0. \end{array}$$

Second step. Set the coefficients of  $x'$  and  $y'$  equal to zero. This gives

$$2h - 2 = 0, \quad 8k - 16 = 0.$$

Third step. Solving, we obtain

$$h = 1, \quad k = 2.$$

Fourth step. Substituting in (4), we obtain

$$x'^2 + 4y'^2 = 16.$$

Plotting on the new axes, we obtain the figure.

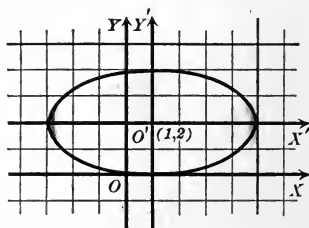

**Ex. 3.** Remove the  $xy$ -term from  $x^2 + 4xy + y^2 = 4$  by rotating the axes.

*Solution.* First step. Set  $x = x' \cos \theta - y' \sin \theta$  and  $y = x' \sin \theta + y' \cos \theta$ , whence

$$\begin{array}{r} \cos^2 \theta \left| x^2 - 2 \sin \theta \cos \theta \right. \left. \begin{array}{l} x'y' + \sin^2 \theta \\ - 4 \sin \theta \cos \theta \\ + \cos^2 \theta \end{array} \right| y'^2 = 4. \\ + 4 \sin \theta \cos \theta \left| \begin{array}{l} + 4 (\cos^2 \theta - \sin^2 \theta) \\ + 2 \sin \theta \cos \theta \end{array} \right. \end{array}$$

or, by 3, p. 12, and 14, p. 13,

$$(5) \quad (1 + 2 \sin 2\theta)x'^2 + 4 \cos 2\theta \cdot x'y' + (1 - 2 \sin 2\theta)y'^2 = 4.$$

Second step. Setting the coefficient of  $x'y'$  equal to zero, we have

$$\cos 2\theta = 0.$$

Third step. Hence

$$2\theta = \frac{\pi}{2} \therefore \theta = \frac{\pi}{4}$$

Fourth step. Substituting in (5), we obtain, since  $\sin \frac{\pi}{2} = 1$  (p. 14),

$$3x'^2 - y'^2 = 4.$$

The locus of this equation is the hyperbola plotted on the new axes in the figure.

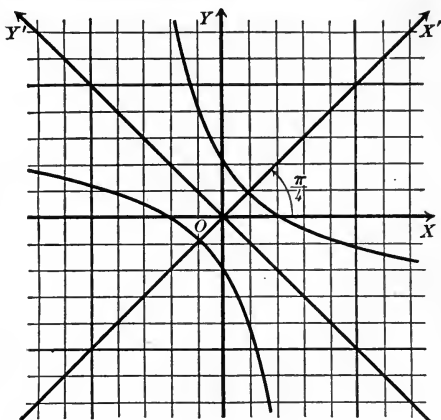

From  $\cos 2\theta = 0$  we get, in general,  $2\theta = \frac{\pi}{2} + n\pi$ , where  $n$  is any positive or negative integer, or zero, and hence  $\theta = \frac{\pi}{4} + n\frac{\pi}{2}$ . Then the  $xy$ -term may be removed by giving  $\theta$  any one of these values. For most purposes we choose the smallest positive value of  $\theta$  as in this example.

**Ex. 4.** Simplify  $x^3 + 6x^2 + 12x - 4y + 4 = 0$  by translating the axes.

*Solution.* First step. Set

$$x = x' + h, \quad y = y' + k.$$

We obtain

$$(6) \quad \begin{array}{r|l} x^3 + 3h & x^2 + 3h^2 \\ + 6 & + 12h \\ & + 12 \end{array} \left| \begin{array}{l} x' - 4y' + h^3 \\ + 6h^2 \\ + 12h \\ - 4k \\ + 4 \end{array} \right| = 0.$$

Second step. Set equal to zero the coefficient of  $x^2$  and the constant term. This gives

$$3h + 6 = 0,$$

$$h^3 + 6h^2 + 12h - 4k + 4 = 0.$$

Third step. Solving,

$$h = -2, \quad k = -1.$$

Fourth step. Substituting in (6), we obtain

$$x'^3 - 4y' = 0,$$

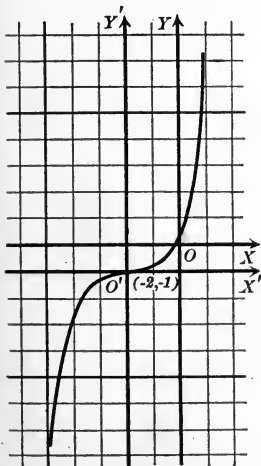

whose locus is the cubical parabola in the figure.



Setting the coefficient of  $y'$  and the constant term equal to zero gives

$$(2) \quad -A \sin \theta + B \cos \theta = 0,$$

$$(3) \quad Ah + Bk + C = 0.$$

From (2),  $\tan \theta = \frac{B}{A}$ , or  $\theta = \tan^{-1} \left( \frac{B}{A} \right)$ .

From (3) we can determine many pairs of values of  $h$  and  $k$ . One pair is

$$h = -\frac{C}{A}, \quad k = 0.$$

Substituting in (1) the last two terms drop out, and dividing by the coefficient of  $x'$  we have left  $x' = 0$ . Q.E.D.

We have moved the origin to a point  $(h, k)$  on the given line  $L$ , since (3) is the condition that  $(h, k)$  lies on the line, and then rotated the axes until the new axis of  $y$  coincides with  $L$ . The particular point chosen for  $(h, k)$  was the point  $O'$  where  $L$  cuts the  $X$ -axis.

This theorem is evident geometrically. For  $x' = 0$  is the equation of the new  $Y$ -axis, and evidently any line may be chosen as the  $Y$ -axis. But the theorem may be used to prove that the locus of every equation of the first degree is a straight line, if we prove it as above, for it is evident that the locus of  $x' = 0$  is a straight line.

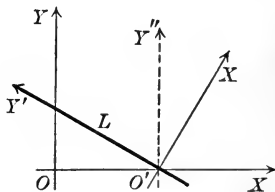

**Theorem VI.** *The term in  $xy$  may always be removed from an equation of the second degree,*

$$Ax^2 + Bxy + Cy^2 + Dx + Ey + F = 0,$$

*by rotating the axes through an angle  $\theta$  such that*

$$(VI) \quad \tan 2\theta = \frac{B}{A - C}.$$

*Proof.* Set  $x = x' \cos \theta - y' \sin \theta$   
and  $y = x' \sin \theta + y' \cos \theta$ .

This gives

$$(4) \quad \begin{array}{l} A \cos^2 \theta \\ + B \sin \theta \cos \theta \\ + C \sin^2 \theta \end{array} \left| \begin{array}{l} x'^2 - 2A \sin \theta \cos \theta \\ + B(\cos^2 \theta - \sin^2 \theta) \\ + 2C \sin \theta \cos \theta \end{array} \right| \begin{array}{l} x'y' + A \sin^2 \theta \\ - B \sin \theta \cos \theta \\ + C \cos^2 \theta \end{array} \left| \begin{array}{l} y'^2 \\ \\ \end{array} \right| \\ + D \cos \theta \left| \begin{array}{l} x' - D \sin \theta \\ + E \sin \theta \end{array} \right| y' + F = 0.$$

Setting the coefficient of  $x'y'$  equal to zero, we have

$$(C - A) 2 \sin \theta \cos \theta + B(\cos^2 \theta - \sin^2 \theta) = 0,$$

or (14, p. 13),  $(C - A) \sin 2\theta + B \cos 2\theta = 0$ .

Hence 
$$\tan 2\theta = \frac{B}{A - C}.$$

If  $\theta$  satisfies this relation, on substituting in (4) we obtain an equation without the term in  $xy$ . Q. E. D.

**Corollary.** *In transforming an equation of the second degree by rotating the axes the constant term is unchanged unless the new equation is multiplied or divided by some constant.*

For the constant term in (4) is the same as that of the given equation.

**Theorem VII.** *The terms of the first degree may be removed from an equation of the second degree,*

$$Ax^2 + Bxy + Cy^2 + Dx + Ey + F = 0,$$

*by translating the axes, provided that the discriminant of the terms of the second degree,  $\Delta = B^2 - 4AC$ , is not zero.*

*Proof.* Set  $x = x' + h$ ,  $y = y' + k$ .

This gives

$$(5) \quad \begin{array}{l} Ax'^2 + Bx'y' + Cy'^2 + 2Ah \\ + Bk \\ + D \end{array} \left| \begin{array}{l} x' + Bh \\ + 2Ck \\ + E \end{array} \right| \begin{array}{l} y' + Ah^2 \\ + Bhk \\ + Ck^2 \\ + Dh \\ + Ek \\ + F \end{array} = 0.$$

Setting equal to zero the coefficients of  $x'$  and  $y'$ , we obtain

$$(6) \quad 2Ah + Bk + D = 0,$$

$$(7) \quad Bh + 2Ck + E = 0.$$

These equations can be solved for  $h$  and  $k$  unless (Theorem IV, p. 81)

$$\frac{2A}{B} = \frac{B}{2C},$$

or 
$$B^2 - 4AC = 0.$$

If the values obtained be substituted in (5), the resulting equation will not contain the terms of the first degree. Q. E. D.

**Corollary I.** *If an equation of the second degree be transformed by translating the axes, the coefficients of the terms of the second degree are unchanged unless the new equation be multiplied or divided by some constant.*

For these coefficients in (5) are the same as in the given equation.

**Corollary II.** *When  $\Delta$  is not zero the locus of an equation of the second degree has a center of symmetry.*

For if the terms of the first degree be removed the locus will be symmetrical with respect to the new origin (Theorem V, p. 66).

If  $\Delta = B^2 - 4AC = 0$ , equations (6) and (7) may still be solved for  $h$  and  $k$  if (Theorem IV, p. 81)  $\frac{2A}{B} = \frac{B}{2C} = \frac{D}{E}$ , when the new origin  $(h, k)$  may be any point on the line  $2Ax + By + D = 0$ . In this case every point on that line will be a center of symmetry.

For example, consider  $x^2 + 4xy + 4y^2 + 4x + 8y + 3 = 0$ . For this equation equations (6) and (7) become

$$2h + 4k + 4 = 0,$$

$$4h + 8k + 8 = 0.$$

In these equations the coefficients are all proportional and there is an infinite number of solutions. One solution is  $h = -2, k = 0$ . For these values the given equation reduces to

$$x^2 + 4xy + 4y^2 - 1 = 0,$$

or 
$$(x + 2y + 1)(x + 2y - 1) = 0.$$

The locus consists of two parallel lines and evidently is symmetrical with respect to any point on the line midway between those lines.

## MISCELLANEOUS PROBLEMS

1. Simplify and plot.

(a)  $y^2 - 5y + 6 = 0$ .

(e)  $x^2 + 4xy + y^2 = 8$ .

(b)  $x^2 + 2xy + y^2 - 6x - 6y + 5 = 0$ .

(f)  $x^2 - 9y^2 - 2x - 36y + 4 = 0$ .

(c)  $y^2 + 6x - 10y + 2 = 0$ .

(g)  $25y^2 - 16x^2 + 50y - 119 = 0$ .

(d)  $x^2 + 4y^2 - 8x - 16y = 0$ .

(h)  $x^2 + 2xy + y^2 - 8x = 0$ .

2. Find the point to which the origin must be moved to remove the terms of the first degree from an equation of the second degree (Theorem VII).

3. To what point  $(h, k)$  must we translate the axes to transform

$$(1 - e^2)x^2 + y^2 - 2px + p^2 = 0 \text{ into } (1 - e^2)x^2 + y^2 - 2e^2px - e^2p^2 = 0?$$

4. Simplify the second equation in problem 3.

5. Derive from a figure the equations for rotating the axes through  $+\frac{\pi}{2}$  and  $-\frac{\pi}{2}$ , and verify by substitution in (II), p. 138.

6. Prove that every equation of the first degree may be transformed into  $y' = 0$  by moving the axes. In how many ways is this possible?

7. The equation for rotating the polar axis through an angle  $\phi$  is  $\theta = \theta' + \phi$ .

8. The equations of transformation from rectangular to polar coördinates, when the pole is the point  $(h, k)$  and the polar axis makes an angle of  $\phi$  with the  $X$ -axis, are

$$x = h + \rho \cos(\theta + \phi),$$

$$y = k + \rho \sin(\theta + \phi).$$

9. The equations of transformation from rectangular coördinates to oblique coördinates are

$$x = x' + y' \cos \omega,$$

$$y = y' \sin \omega,$$

if the  $X$ -axes coincide and the angle between  $OX'$  and  $OY'$  is  $\omega$ .

10. The equations of transformation from one set of oblique axes to any other set with the same origin are

$$x = x' \frac{\sin(\omega - \phi)}{\sin \omega} + y' \frac{\sin(\omega - \psi)}{\sin \omega},$$

$$y = x' \frac{\sin \phi}{\sin \omega} + y' \frac{\sin \psi}{\sin \omega},$$

where  $\omega$  is the angle between  $OX$  and  $OY$ ,  $\phi$  is the angle from  $OX$  to  $OX'$ , and  $\psi$  is the angle from  $OX$  to  $OY'$ .



## CHAPTER VIII

### CONIC SECTIONS AND EQUATIONS OF THE SECOND DEGREE

**67. Equation in polar coördinates.** The locus of a point  $P$  is called a **conic section**\* if the ratio of its distances from a fixed point  $F$  and a fixed line  $DD$  is constant.  $F$  is called the **focus**,  $DD$  the **directrix**, and the constant ratio the **eccentricity**. The line through the focus perpendicular to the directrix is called the **principal axis**.

**Theorem I.** *If the pole is the focus and the polar axis the principal axis of a conic section, then the polar equation of the conic is*

$$(I) \quad \rho = \frac{ep}{1 - e \cos \theta},$$

where  $e$  is the eccentricity and  $p$  is the distance from the directrix to the focus.

*Proof.* Let  $P$  be any point on the conic. Then, by definition,

$$\frac{FP}{EP} = e.$$

From the figure,  $FP = \rho$

and  $EP = HM = p + \rho \cos \theta$ .

Substituting these values of  $FP$  and  $EP$ , we have

$$\frac{\rho}{p + \rho \cos \theta} = e;$$

or, solving for  $\rho$ ,

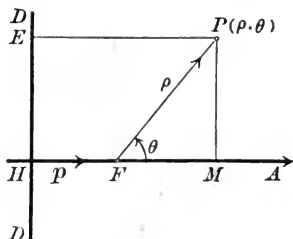
$$\rho = \frac{ep}{1 - e \cos \theta}.$$

Q. E. D.

\* Because these curves may be regarded as the intersections of a cone of revolution with a plane.

From (I) we see that

1. A conic is symmetrical with respect to the principal axis.

For substituting  $-\theta$  for  $\theta$  changes only the form of the equation, since  $\cos(-\theta) = \cos \theta$ .

2. In plotting, no values of  $\theta$  need be excluded.

The other properties to be discussed (p. 127) show that three cases must be considered according as  $e \geq 1$ .

**The parabola  $e = 1$ .** When  $e = 1$ , (I) becomes

$$\rho = \frac{p}{1 - \cos \theta},$$

and the locus is called a **parabola**.

1. For  $\theta = 0$   $\rho = \infty$ , and for  $\theta = \pi$   $\rho = \frac{p}{2}$ . The parabola therefore crosses the principal axis but once at the point  $O$ , called the **vertex**, which is  $\frac{p}{2}$  to the left of the focus  $F$ , or midway between  $F$  and  $DD$ .

2.  $\rho$  becomes infinite when the denominator,  $1 - \cos \theta$ , vanishes. If  $1 - \cos \theta = 0$ , then  $\cos \theta = 1$ ; and hence  $\theta = 0$  is the only value less than  $2\pi$  for which  $\rho$  is infinite.

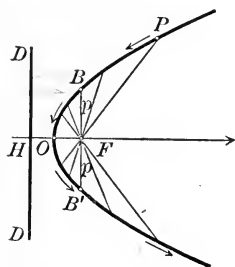

3. When  $\theta$  increases from 0 to  $\frac{\pi}{2}$ ,

then  $\cos \theta$  decreases from 1 to 0,

$1 - \cos \theta$  increases from 0 to 1,

$\rho$  decreases from  $\infty$  to  $p$ ,

and the point  $P(\rho, \theta)$  describes the parabola from infinity to  $B$ .

When  $\theta$  increases from  $\frac{\pi}{2}$  to  $\pi$ ,

then  $\cos \theta$  decreases from 0 to  $-1$ ,

$1 - \cos \theta$  increases from 1 to 2,

$\rho$  decreases from  $p$  to  $\frac{p}{2}$ ,

and the point  $P(\rho, \theta)$  describes the parabola from  $B$  to the vertex  $O$ .

On account of the symmetry with respect to the axis, when  $\theta$  increases from  $\pi$  to  $\frac{3\pi}{2}$ ,  $P(\rho, \theta)$  describes the parabola from  $O$  to  $B'$ ; and when  $\theta$  increases from  $\frac{3\pi}{2}$  to  $2\pi$ , from  $B'$  to infinity.

When  $e < 1$  the conic is called an **ellipse**, and when  $e > 1$ , an **hyperbola**. The points of similarity and difference in these curves are brought out by considering them simultaneously.

*The ellipse,  $e < 1$ .*

1. For  $\theta = 0$   $\rho = \frac{ep}{1-e} = \frac{e}{1-e}p$ .

As  $e < 1$ , the denominator, and hence  $\rho$ , is positive, so that we obtain a point  $A$  on the ellipse to the *right* of  $F$ .

As  $\frac{e}{1-e} > 1$  when  $e < 1$ , according as  $e \leq \frac{1}{2}$ , then  $FA$  may be greater, equal to, or less than  $FH$ .

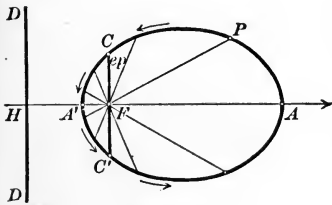

For  $\theta = \pi$   $\rho = \frac{ep}{1+e} = \frac{e}{1+e}p$ .  $\rho$  is positive, and hence we obtain a point  $A'$  to the left of  $F$ .

As  $\frac{e}{1+e} < 1$ , then  $\rho < p$ ; so  $A'$  lies between  $H$  and  $F$ .

$A$  and  $A'$  are called the **vertices** of the ellipse.

*The hyperbola,  $e > 1$ .*

1. For  $\theta = 0$   $\rho = \frac{ep}{1-e} = \frac{e}{1-e}p$ .

As  $e > 1$ , the denominator, and hence  $\rho$ , is negative, so that we obtain a point  $A$  on the hyperbola to the *left* of  $F$ .

As  $\frac{e}{1-e} > 1$  (numerically) when  $e > 1$ , then  $\rho > p$ ; so  $A$  lies to the left of  $H$ .

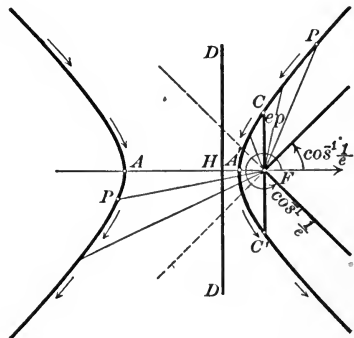

For  $\theta = \pi$   $\rho = \frac{ep}{1+e} = \frac{e}{1+e}p$ .  $\rho$  is positive, and hence we obtain a second point  $A'$  to the left of  $F$ .

As  $\frac{e}{1+e} < 1$ , then  $\rho < p$ ; so  $A'$  lies between  $H$  and  $F$ .

$A$  and  $A'$  are called the **vertices** of the hyperbola.

The ellipse,  $e < 1$ .

2.  $\rho$  becomes infinite if

$$1 - e \cos \theta = 0,$$

or  $\cos \theta = \frac{1}{e}$ .

As  $e < 1$ , then  $\frac{1}{e} > 1$ ; and hence there are *no* values of  $\theta$  for which  $\rho$  becomes infinite.

3. When

$$\theta \text{ increases from } 0 \text{ to } \frac{\pi}{2},$$

then  $\cos \theta$  decreases from 1 to 0,  
 $1 - e \cos \theta$  increases from  $1 - e$  to 1;  
 hence  $\rho$  decreases from  $\frac{ep}{1 - e}$  to  $ep$ ,  
 and  $P(\rho, \theta)$  describes the ellipse from  $A$  to  $C$ .

When  $\theta$  increases from  $\frac{\pi}{2}$  to  $\pi$ ,

then  $\cos \theta$  decreases from 0 to  $-1$ ,  
 $1 - e \cos \theta$  increases from 1 to  $1 + e$ ;  
 hence  $\rho$  decreases from  $ep$  to  $\frac{ep}{1 + e}$ ,  
 and  $P(\rho, \theta)$  describes the ellipse from  $C$  to  $A'$ .

The rest of the ellipse,  $A'C'A$ , may be obtained from the symmetry with respect to the principal axis.

The ellipse is a *closed curve*.

The hyperbola,  $e > 1$ .

2.  $\rho$  becomes infinite if

$$1 - e \cos \theta = 0,$$

or  $\cos \theta = \frac{1}{e}$ .

As  $e > 1$ , then  $\frac{1}{e} < 1$ ; and hence there are *two* values of  $\theta$  for which  $\rho$  becomes infinite.

3. When

$$\theta \text{ increases from } 0 \text{ to } \cos^{-1}\left(\frac{1}{e}\right),$$

then  $\cos \theta$  decreases from 1 to  $\frac{1}{e}$ ,  
 $1 - e \cos \theta$  increases from  $1 - e$  to 0;  
 hence  $\rho$  decreases from  $\frac{ep}{1 - e}$  to  $-\infty$ ,  
 and  $P(\rho, \theta)$  describes the lower half of the left-hand branch from  $A$  to infinity.

When

$$\theta \text{ increases from } \cos^{-1}\left(\frac{1}{e}\right) \text{ to } \frac{\pi}{2},$$

then  $\cos \theta$  decreases from  $\frac{1}{e}$  to 0,  
 $1 - e \cos \theta$  increases from 0 to 1;  
 hence  $\rho$  decreases from  $\infty$  to  $ep$ ,  
 and  $P(\rho, \theta)$  describes the upper part of the right-hand branch from infinity to  $C$ .

When  $\theta$  increases from  $\frac{\pi}{2}$  to  $\pi$ ,

then  $\cos \theta$  decreases from 0 to  $-1$ ,  
 $1 - e \cos \theta$  increases from 1 to  $1 + e$ ;  
 hence  $\rho$  decreases from  $ep$  to  $\frac{ep}{1 + e}$ ,  
 and  $P(\rho, \theta)$  describes the hyperbola from  $C$  to  $A'$ .

The rest of the hyperbola,  $A'C'A$  to infinity and infinity to  $A$ , may be obtained from the symmetry with respect to the principal axis.

The hyperbola has *two infinite branches*.

## PROBLEMS

1. Plot and discuss the following conics. Find  $e$  and  $p$ , and draw the focus and directrix of each.

$$(a) \rho = \frac{2}{1 - \cos \theta}.$$

$$(e) \rho = \frac{3}{3 - \cos \theta}.$$

$$(b) \rho = \frac{2}{1 - \frac{1}{2} \cos \theta}.$$

$$(f) \rho = \frac{6}{2 - 3 \cos \theta}.$$

$$(c) \rho = \frac{8}{1 - 2 \cos \theta}.$$

$$(g) \rho = \frac{2}{2 - \cos \theta}.$$

$$(d) \rho = \frac{5}{2 - 2 \cos \theta}.$$

$$(h) \rho = \frac{12}{3 - 4 \cos \theta}.$$

2. Transform the equations in problem 1 into rectangular coördinates, simplify by the Rule on p. 141, and discuss the resulting equations. Find the coördinates of the focus and the equation of the directrix in the new variables. Plot the locus of each equation, its focus, and directrix on the new axes.

*Ans.* (a)  $y^2 = 4x$ ,  $(1, 0)$ ,  $x = -1$ .

(b)  $\frac{x^2}{\frac{6.4}{9}} + \frac{y^2}{\frac{1.6}{3}} = 1$ ,  $(-\frac{4}{3}, 0)$ ,  $x = -\frac{16}{3}$ .

(c)  $\frac{x^2}{\frac{6.4}{9}} - \frac{y^2}{\frac{6.4}{3}} = 1$ ,  $(\frac{16}{3}, 0)$ ,  $x = \frac{4}{3}$ .

(d)  $y^2 = 5x$ ,  $(\frac{5}{4}, 0)$ ,  $x = -\frac{5}{4}$ .

(e)  $\frac{x^2}{\frac{8.1}{6.4}} + \frac{y^2}{\frac{9}{8}} = 1$ ,  $(-\frac{3}{8}, 0)$ ,  $x = -\frac{27}{8}$ .

(f)  $\frac{x^2}{\frac{1.44}{2.5}} - \frac{y^2}{\frac{3.6}{5}} = 1$ ,  $(\frac{18}{5}, 0)$ ,  $x = \frac{8}{5}$ .

(g)  $\frac{x^2}{\frac{1.6}{9}} + \frac{y^2}{\frac{4}{3}} = 1$ ,  $(-\frac{2}{3}, 0)$ ,  $x = -\frac{8}{3}$ .

(h)  $\frac{x^2}{\frac{1.2}{4.9}} - \frac{y^2}{\frac{9.6}{1.4}} = 1$ ,  $(\frac{48}{7}, 0)$ ,  $x = \frac{27}{7}$ .

3. Transform (I) into rectangular coördinates, simplify, and find the coördinates of the focus and the equation of the directrix in the new rectangular coördinates if (a)  $e = 1$ , (b)  $e \geq 1$ .

*Ans.* (a)  $y^2 = 2px$ ,  $(\frac{p}{2}, 0)$ ,  $x = -\frac{p}{2}$

$$(b) \frac{x^2}{\frac{e^2 p^2}{(1-e^2)^2}} + \frac{y^2}{\frac{e^2 p^2}{1-e^2}} = 1, \left(-\frac{e^2 p}{1-e^2}, 0\right), x = -\frac{p}{1-e^2}.$$

4. Derive the equation of a conic section when (a) the focus lies to the left of the directrix; (b) the polar axis is parallel to the directrix.

$$\text{Ans. (a) } \rho = \frac{ep}{1 + e \cos \theta}; \quad \text{(b) } \rho = \frac{ep}{1 - e \sin \theta}.$$

5. Plot and discuss the following conics. Find  $e$  and  $p$ , and draw the directrix of each.

$$(a) \rho = \frac{8}{1 + \cos \theta}.$$

$$(c) \rho = \frac{7}{3 + 10 \cos \theta}.$$

$$(b) \rho = \frac{6}{1 - \sin \theta}.$$

$$(d) \rho = \frac{5}{3 - \sin \theta}.$$

### 68. Transformation to rectangular coördinates.

**Theorem II.** *If the origin is the focus and the X-axis the principal axis of a conic section, then its equation is*

$$(II) \quad (1 - e^2)x^2 + y^2 - 2e^2px - e^2p^2 = 0,$$

where  $e$  is the eccentricity and  $x = -p$  is the equation of the directrix.

*Proof.* Clearing fractions in (I), p. 149, we obtain

$$\rho - e\rho \cos \theta = ep.$$

Set  $\rho = \pm \sqrt{x^2 + y^2}$  and  $\rho \cos \theta = x$  (p. 131). This gives

$$\pm \sqrt{x^2 + y^2} - ex = ep,$$

or

$$\pm \sqrt{x^2 + y^2} = ex + ep.$$

Squaring and collecting like powers of  $x$  and  $y$ , we have the required equation. Since the directrix  $DD$  (Fig., p. 149) lies  $p$  units to the left of  $F$  its equation is  $x = -p$ . Q.E.D.

### 69. Simplification and discussion of the equation in rectangular coördinates. The parabola, $e = 1$ .

When  $e = 1$ , (II) becomes

$$y^2 - 2px - p^2 = 0.$$

Applying the Rule on p. 141, we substitute

$$(1) \quad x = x' + h, \quad y = y' + k,$$

obtaining

$$(2) \quad y'^2 - 2px' + 2ky' + k^2 - 2ph - p^2 = 0.$$

Set the coefficient of  $y'$  and the constant term equal to zero and solve for  $h$  and  $k$ . This gives

$$(3) \quad h = -\frac{p}{2}, \quad k = 0.$$

Substituting these values in (2) and dropping primes, the equation of the parabola becomes  $y^2 = 2px$ .

From (3) we see that the origin has been removed from  $F$  to  $O$ , the vertex of the parabola. It is easily seen that the new coordinates of the focus are  $(\frac{p}{2}, 0)$ , and the new equation of the directrix is  $x = -\frac{p}{2}$ . Hence

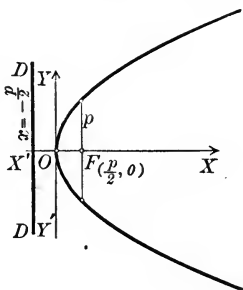

**Theorem III.** *If the origin is the vertex and the X-axis the axis of a parabola, then its equation is*

$$(III) \quad y^2 = 2px.$$

The focus is the point  $(\frac{p}{2}, 0)$ , and the equation of the directrix is  $x = -\frac{p}{2}$ .

A general discussion of (III) gives us the following properties of the parabola in addition to those already obtained (p. 150).

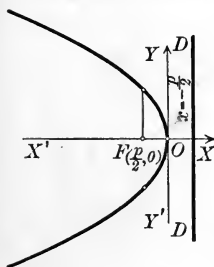

1. It passes through the origin but does not cut the axes elsewhere.

2. Values of  $x$  having the sign opposite to that of  $p$  are to be excluded (Rule, p. 66). Hence the curve lies to the *right* of  $YY'$  when  $p$  is *positive* and to the *left* when  $p$  is *negative*.

3. No values of  $y$  are to be excluded; hence the curve extends indefinitely up and down.

**Theorem IV.** *If the origin is the vertex and the Y-axis the axis of a parabola, then its equation is*

$$(IV) \quad x^2 = 2py.$$

The focus is the point  $\left(0, \frac{p}{2}\right)$ , and the equation of the directrix is  $y = -\frac{p}{2}$ .

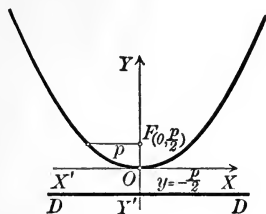

*Proof.* Transform (III) by rotating the axes through  $-\frac{\pi}{2}$ . Equations (II), p.138, give us for  $\theta = -\frac{\pi}{2}$

$$x = y',$$

$$y = -x'.$$

Substituting in (III) and dropping primes, we obtain  $x^2 = 2py$ .

Q.E.D.

After rotating the axes the whole figure is turned through  $\frac{\pi}{2}$  in the positive direction.

The parabola lies *above* or *below* the  $X$ -axis according as  $p$  is *positive* or *negative*.

Equations (III) and (IV) are called the *typical forms* of the equation of the parabola.

Equations of the forms

$$Ax^2 + Ey = 0 \text{ and } Cy^2 + Dx = 0,$$

where  $A$ ,  $E$ ,  $C$ , and  $D$  are different from zero, may, by transposition and division, be written in one of the typical forms (III) or (IV), so that in each case the locus is a parabola.

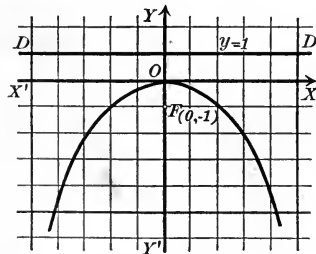

**Ex. 1.** Plot the locus of  $x^2 + 4y = 0$  and find the focus and directrix.

*Solution.* The given equation may be written

$$x^2 = -4y.$$

Comparing with (IV), the locus is seen to be a parabola for which  $p = -2$ . Its focus is therefore the point  $(0, -1)$  and its directrix the line  $y = 1$ .

**Ex. 2.** Find the equation of the parabola whose vertex is the point  $O'(3, -2)$  and whose directrix is parallel to the  $Y$ -axis, if  $p = 3$ .



*Solution.* Referred to  $O'X'$  and  $O'Y'$  as axes, the equation of the parabola is (Theorem III)

$$(4) \quad y'^2 = 6x'$$

The equation for translating the axes from  $O$  to  $O'$  are (Theorem I, p. 136)

$$x = x' + 3, \quad y = y' - 2,$$

whence

$$(5) \quad x' = x - 3, \quad y' = y + 2.$$

Substituting in (4), we obtain as the required equation

$$(y + 2)^2 = 6(x - 3),$$

or 
$$y^2 - 6x + 4y + 22 = 0.$$

Referred to  $O'X'$  and  $O'Y'$ , the coordinates of  $F$  are (Theorem III)  $(\frac{3}{2}, 0)$  and the equation of  $DD$  is  $x' = -\frac{3}{2}$ . By (5) we see that, referred to  $OX$  and  $OY$ , the coordinates of  $F$  are  $(\frac{9}{2}, -2)$  and the equation of  $DD$  is  $x = \frac{3}{2}$ .

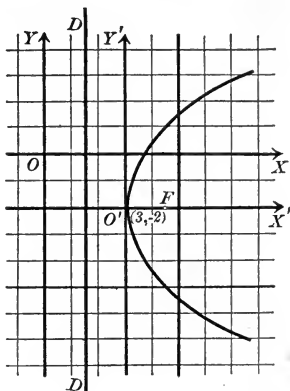

PROBLEMS

1. Plot the locus of the following equations. Draw the focus and directrix in each case.

(a)  $y^2 = 4x$ .

(d)  $y^2 - 6x = 0$ .

(b)  $y^2 + 4x = 0$ .

(e)  $x^2 + 10y = 0$ .

(c)  $x^2 - 8y = 0$ .

(f)  $y^2 + x = 0$ .

2. If the directrix is parallel to the  $Y$ -axis, find the equation of the parabola for which

(a)  $p = 6$ , if the vertex is  $(3, 4)$ .

*Ans.*  $(y - 4)^2 = 12(x - 3)$ .

(b)  $p = -4$ , if the vertex is  $(2, -3)$ .

*Ans.*  $(y + 3)^2 = -8(x - 2)$ .

(c)  $p = 8$ , if the vertex is  $(-5, 7)$ .

*Ans.*  $(y - 7)^2 = 16(x + 5)$ .

(d)  $p = 4$ , if the vertex is  $(h, k)$ .

*Ans.*  $(y - k)^2 = 8(x - h)$ .

3. The chord through the focus perpendicular to the axis is called the **latus rectum**. Find the length of the latus rectum of  $y^2 = 2px$ . *Ans.*  $2p$ .

4. What is the equation of the parabola whose axis is parallel to the axis of  $y$  and whose vertex is the point  $(\alpha, \beta)$ ? *Ans.*  $(x - \alpha)^2 = 2p(y - \beta)$ .

5. Transform to polar coordinates and discuss the resulting equations (a)  $y^2 = 2px$ , (b)  $x^2 = 2py$ .

6. Prove that the abscissas of two points on the parabola (III) are proportional to the squares of the ordinates of those points.

**70. Simplification and discussion of the equation in rectangular coördinates. Central conics,  $e \geq 1$ .** When  $e \geq 1$ , equation (II), p. 154, is

$$(1 - e^2)x^2 + y^2 - 2e^2px - e^2p^2 = 0.$$

To simplify (Rule, p. 141), set

$$(1) \quad x = x' + h, \quad y = y' + k,$$

which gives

$$(2) \quad (1 - e^2)x'^2 + y'^2 + 2h(1 - e^2)x' + 2ky' + (1 - e^2)h^2 + k^2 - 2e^2ph - e^2p^2 = 0.$$

Setting the coefficients of  $x'$  and  $y'$  equal to zero gives

$$2h(1 - e^2) - 2e^2p = 0, \quad 2k = 0,$$

whence

$$(3) \quad h = \frac{e^2p}{1 - e^2}, \quad k = 0.$$

Substituting in (2) and dropping primes, we obtain

$$(1 - e^2)x^2 + y^2 - \frac{e^2p^2}{1 - e^2} = 0,$$

or

$$(4) \quad \frac{x^2}{\frac{e^2p^2}{(1 - e^2)^2}} + \frac{y^2}{1 - e^2} = 1.$$

This is obtained by transposing the constant term, dividing by it, and then dividing numerator and denominator of the first fraction by  $1 - e^2$ .

*The ellipse,  $e < 1$ .*

From (3) it is seen that  $h$  is *positive* when  $e < 1$ . Hence the new origin  $O$  lies to the *right* of the focus  $F$ .

*The hyperbola,  $e > 1$ .*

From (3) it is seen that  $h$  is *negative* when  $e > 1$ . Hence the new origin  $O$  lies to the *left* of the focus  $F$ .

Further,  $\frac{e^2}{1 - e^2} > 1$  numerically, so  $h > p$  numerically; and hence the new origin lies to the left of the directrix  $DD$ .

The locus of (4) is symmetrical with respect to  $YY'$  (Theorem V, p. 66). Hence  $O$  is the middle point of  $AA'$ . Construct in

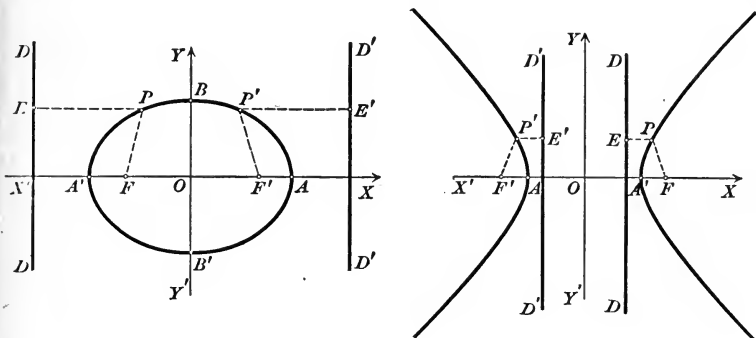

either figure  $F'$  and  $D'D'$  symmetrical respectively to  $F$  and  $DD$  with respect to  $YY'$ . Then  $F'$  and  $D'D'$  are a new focus and directrix.

For let  $P$  and  $P'$  be two points on the curve, symmetrical with respect to  $YY'$ . Then from the symmetry  $PF = P'F'$  and  $PE = P'E'$ . But since, by definition,  $\frac{PF}{PE} = e$ , then  $\frac{P'F'}{P'E'} = e$ . Hence the same conic is traced by  $P'$ , using  $F'$  as focus and  $D'D'$  as directrix, as is traced by  $P$ , using  $F$  as focus and  $DD$  as directrix.

Since the locus of (4) is symmetrical with respect to the origin (Theorem V, p. 66), it is called a **central conic**, and the center of symmetry is called the **center**. Hence *a central conic has two foci and two directrices*.

The coördinates of the focus  $F$  in either figure are

$$\left( -\frac{e^2 p}{1 - e^2}, 0 \right).$$

For the old coördinates of  $F$  were  $(0, 0)$ . Substituting in (1), the new coördinates are  $x' = -h$ ,  $y' = -k$ , or, from (3),  $\left( -\frac{e^2 p}{1 - e^2}, 0 \right)$ .

The coördinates of  $F'$  are therefore  $\left( \frac{e^2 p}{1 - e^2}, 0 \right)$ .

The new equation of the directrix  $DD$  is  $x = -\frac{p}{1 - e^2}$ .

For from (1) and (3),  $x = x' + \frac{e^2 p}{1 - e^2}$ ,  $y = y'$ . Substituting in  $x = -p$  (Theorem II) and dropping primes, we obtain  $x = -\frac{p}{1 - e^2}$ .

Hence the equation of  $D'D'$  is  $x = \frac{p}{1 - e^2}$ .

We thus have the

**Lemma.** *The equation of a central conic whose center is the origin and whose principal axis is the X-axis is*

$$(4) \quad \frac{x^2}{\frac{e^2 p^2}{(1 - e^2)^2}} + \frac{y^2}{\frac{e^2 p^2}{1 - e^2}} = 1.$$

*Its foci are the points*  $\left(\pm \frac{e^2 p}{1 - e^2}, 0\right)$

*and its directrices are the lines*  $x = \pm \frac{p}{1 - e^2}$ .

*The ellipse,  $e < 1$ .*

For convenience set

$$(5) \quad a = \frac{ep}{1 - e^2}, \quad b^2 = \frac{e^2 p^2}{1 - e^2}, \quad c = \frac{e^2 p}{1 - e^2}.$$

$a^2$  and  $b^2$  are the denominators in (4) and  $c$  is the abscissa of one focus. Since  $e < 1$ ,  $1 - e^2$  is positive; and hence  $a$ ,  $b^2$ , and  $c$  are positive.

We have at once

$$\begin{aligned} a^2 - b^2 &= \frac{e^2 p^2}{(1 - e^2)^2} - \frac{e^2 p^2}{1 - e^2} \\ &= \frac{e^4 p^2}{(1 - e^2)^2} = c^2 \end{aligned}$$

and

$$\frac{a^2}{c} = \frac{e^2 p^2}{(1 - e^2)^2} \div \frac{e^2 p}{1 - e^2} = \frac{p}{1 - e^2}.$$

Hence the directrices (Lemma) are the lines  $x = \pm \frac{a^2}{c}$ .

By substitution from (5) in (4) we obtain

$$\frac{x^2}{a^2} + \frac{y^2}{b^2} = 1.$$

*The hyperbola,  $e > 1$ .*

For convenience set

$$(6) \quad a = -\frac{ep}{1 - e^2}, \quad b^2 = -\frac{e^2 p^2}{1 - e^2}, \quad c = -\frac{e^2 p}{1 - e^2}.$$

$a^2$  and  $-b^2$  are the denominators in (4) and  $c$  is the abscissa of one focus. Since  $e > 1$ ,  $1 - e^2$  is negative; and hence  $a$ ,  $b^2$ , and  $c$  are positive.

We have at once

$$\begin{aligned} a^2 + b^2 &= \frac{e^2 p^2}{(1 - e^2)^2} - \frac{e^2 p^2}{1 - e^2} \\ &= \frac{e^4 p^2}{(1 - e^2)^2} = c^2 \end{aligned}$$

and

$$\frac{a^2}{c} = \frac{e^2 p^2}{(1 - e^2)^2} \div -\frac{e^2 p}{1 - e^2} = -\frac{p}{1 - e^2}.$$

Hence the directrices (Lemma) are the lines  $x = \pm \frac{a^2}{c}$ .

By substitution from (6) in (4) we obtain

$$\frac{x^2}{a^2} - \frac{y^2}{b^2} = 1.$$

The ellipse,  $e < 1$ .

The intercepts are  $x = \pm a$  and  $y = \pm b$ .  $AA' = 2a$  is called the major axis and  $BB' = 2b$  the minor axis. Since  $a^2 - b^2 = c^2$  is positive, then  $a > b$ , and the major axis is greater than the minor axis.

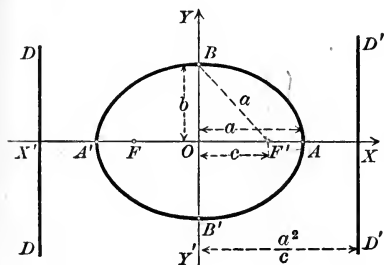

Hence we may restate the Lemma as follows.

**Theorem V.** The equation of an ellipse whose center is the origin and whose foci are on the X-axis is

$$(V) \quad \frac{x^2}{a^2} + \frac{y^2}{b^2} = 1,$$

where  $2a$  is the major axis and  $2b$  the minor axis. If  $c^2 = a^2 - b^2$ , then the foci are  $(\pm c, 0)$  and the directrices are  $x = \pm \frac{a^2}{c}$ .

Equations (5) also enable us to express  $e$  and  $p$ , the constants of (I), p. 149, in terms of  $a$ ,  $b$ , and  $c$ , the constants of (V). For

$$(7) \quad \frac{c}{a} = \frac{e^2 p}{1 - e^2} \div \frac{ep}{1 - e^2} = e$$

and

$$(9) \quad \frac{b^2}{c} = \frac{e^2 p^2}{1 - e^2} \div \frac{e^2 p}{1 - e^2} = p.$$

The hyperbola,  $e > 1$ .

The intercepts are  $x = \pm a$ , but the hyperbola does not cut the Y-axis.  $AA' = 2a$  is called the transverse axis and  $BB' = 2b$  the conjugate axis.

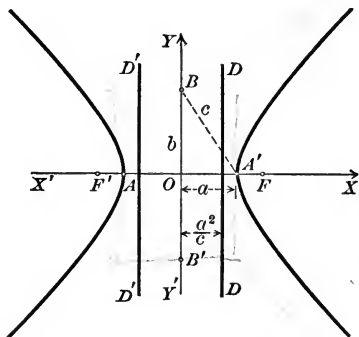

Hence we may restate the Lemma as follows.

**Theorem VI.** The equation of an hyperbola whose center is the origin and whose foci are on the X-axis is

$$(VI) \quad \frac{x^2}{a^2} - \frac{y^2}{b^2} = 1,$$

where  $2a$  is the transverse axis and  $2b$  the conjugate axis. If  $c^2 = a^2 + b^2$ , then the foci are  $(\pm c, 0)$  and the directrices are  $x = \pm \frac{a^2}{c}$ .

Equations (6) also enable us to express  $e$  and  $p$ , the constants of (I), p. 149, in terms of  $a$ ,  $b$ , and  $c$ , the constants of (VI). For

$$(8) \quad \frac{c}{a} = -\frac{e^2 p}{1 - e^2} \div -\frac{ep}{1 - e^2} = e$$

and

$$(10) \quad \frac{b^2}{c} = -\frac{e^2 p^2}{1 - e^2} \div -\frac{e^2 p}{1 - e^2} = p.$$

*The ellipse,  $e < 1$ .*

In the figure  $OB = b$ ,  $OF' = c$ ; and since  $c^2 = a^2 - b^2$ , then  $BF' = a$ . Hence to draw the foci, with  $B$  as a center and radius  $OA$ , describe arcs cutting  $XX'$  at  $F$  and  $F'$ . Then  $F$  and  $F'$  are the foci.

If  $a = b$ , then (V) becomes

$$x^2 + y^2 = a^2,$$

whose locus is a circle.

Transform (V) by rotating the axes through an angle of  $-\frac{\pi}{2}$  (Theorem II, p. 138). We obtain

**Theorem VII.** *The equation of an ellipse whose center is the origin and whose foci are on the Y-axis is*

$$(VII) \quad \frac{x^2}{b^2} + \frac{y^2}{a^2} = 1,$$

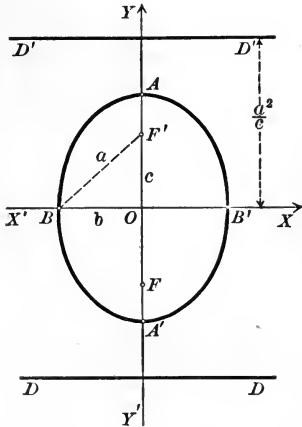

where  $2a$  is the major axis and  $2b$  is the minor axis. If  $c^2 = a^2 - b^2$ , the foci are  $(0, \pm c)$  and the directrices are the lines  $y = \pm \frac{a^2}{c}$ .

*The hyperbola,  $e > 1$ .*

In the figure  $OB = b$ ,  $OA' = a$ ; and since  $c^2 = a^2 + b^2$ , then  $BA' = c$ . Hence to draw the foci, with  $O$  as a center and radius  $BA'$ , describe arcs cutting  $XX'$  at  $F$  and  $F'$ . Then  $F$  and  $F'$  are the foci.

If  $a = b$ , then (VI) becomes

$$x^2 - y^2 = a^2,$$

whose locus is called an **equilateral hyperbola**.

Transform (VI) by rotating the axes through an angle of  $-\frac{\pi}{2}$  (Theorem II, p. 138). We obtain

**Theorem VIII.** *The equation of an hyperbola whose center is the origin and whose foci are on the Y-axis is*

$$(VIII) \quad -\frac{x^2}{b^2} + \frac{y^2}{a^2} = 1,$$

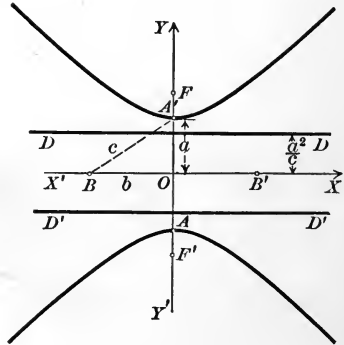

where  $2a$  is the transverse axis and  $2b$  is the conjugate axis. If  $c^2 = a^2 + b^2$ , the foci are  $(0, \pm c)$  and the directrices are the lines  $y = \pm \frac{a^2}{c}$ .

*The ellipse,  $e < 1$ .*

*The hyperbola,  $e > 1$ .*

The essential difference between (V) and (VII) is that in (V) the denominator of  $x^2$  is larger than that of  $y^2$ , while in (VII) the denominator of  $y^2$  is the larger. (V) and (VII) are called the *typical forms* of the equation of an ellipse.

The essential difference between (VI) and (VIII) is that the coefficient of  $y^2$  is negative in (VI), while in (VIII) the coefficient of  $x^2$  is negative. (VI) and (VIII) are called the *typical forms* of the equation of an hyperbola.

An equation of the form

$$Ax^2 + Cy^2 + F = 0,$$

where  $A$ ,  $C$ , and  $F$  are all different from zero, may always be written in the form

$$(11) \quad \frac{x^2}{\alpha} + \frac{y^2}{\beta} = 1.$$

By transposing the constant term and then dividing by it, and dividing numerator and denominator of the resulting fractions by  $A$  and  $C$  respectively.

*The locus of this equation will be*

1. *An ellipse if  $\alpha$  and  $\beta$  are both positive.*  $a^2$  will be equal to the larger denominator and  $b^2$  to the smaller.

2. *An hyperbola if  $\alpha$  and  $\beta$  have opposite signs.*  $a^2$  will be equal to the positive denominator and  $b^2$  to the negative denominator.

3. *If  $\alpha$  and  $\beta$  are both negative, (11) will have no locus.*

**Ex. 1.** Find the axes, foci, directrices, and eccentricity of the ellipse  $4x^2 + y^2 = 16$ .

*Solution.* Dividing by 16, we obtain

$$\frac{x^2}{4} + \frac{y^2}{16} = 1.$$

The second denominator is the larger. By comparison with (VII),

$$b^2 = 4, \quad a^2 = 16, \quad c^2 = 16 - 4 = 12.$$

$$\text{Hence} \quad b = 2, \quad a = 4, \quad c = \sqrt{12}.$$

The positive sign only is used when we extract the square root, because  $a$ ,  $b$ , and  $c$  are essentially positive.

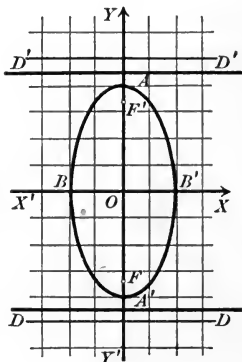

Hence the major axis  $AA' = 8$ , the minor axis  $BB' = 4$ , the foci  $F$  and  $F'$  are the points  $(0, \pm\sqrt{12})$ , and the equations of the directrices  $DD$  and  $D'D'$  are  $y = \pm \frac{a^2}{c} = \pm \frac{16}{\sqrt{12}} = \pm \frac{4}{3}\sqrt{12}$ .

From (7) and (9),  $e = \frac{\sqrt{12}}{4}$  and  $p = \frac{4}{\sqrt{12}} = \frac{1}{3}\sqrt{12}$ .

### PROBLEMS

1. Plot the loci, directrices, and foci of the following equations and find  $e$  and  $p$ .

- |                            |                          |
|----------------------------|--------------------------|
| (a) $x^2 + 9y^2 = 81$ .    | (e) $9y^2 - 4x^2 = 36$ . |
| (b) $9x^2 - 16y^2 = 144$ . | (f) $x^2 - y^2 = 25$ .   |
| (c) $16x^2 + y^2 = 25$ .   | (g) $4x^2 + 7y^2 = 13$ . |
| (d) $4x^2 + 9y^2 = 36$ .   | (h) $5x^2 - 3y^2 = 14$ . |

2. Find the equation of the ellipse whose center is the origin and whose foci are on the  $X$ -axis if

- |                                |                                      |
|--------------------------------|--------------------------------------|
| (a) $a = 5, b = 3$ .           | <i>Ans.</i> $9x^2 + 25y^2 = 225$ .   |
| (b) $a = 6, e = \frac{1}{3}$ . | <i>Ans.</i> $32x^2 + 36y^2 = 1152$ . |
| (c) $b = 4, c = 3$ .           | <i>Ans.</i> $16x^2 + 25y^2 = 400$ .  |
| (d) $c = 8, e = \frac{2}{3}$ . | <i>Ans.</i> $5x^2 + 9y^2 = 720$ .    |

3. Find the equation of the hyperbola whose center is the origin and whose foci are on the  $X$ -axis if

- |                                |                                    |
|--------------------------------|------------------------------------|
| (a) $a = 3, b = 5$ .           | <i>Ans.</i> $25x^2 - 9y^2 = 225$ . |
| (b) $a = 4, c = 5$ .           | <i>Ans.</i> $9x^2 - 16y^2 = 144$ . |
| (c) $e = \frac{3}{2}, a = 5$ . | <i>Ans.</i> $5x^2 - 4y^2 = 125$ .  |
| (d) $c = 8, e = 4$ .           | <i>Ans.</i> $15x^2 - y^2 = 60$ .   |

4. Show that the latus rectum (chord through the focus perpendicular to the principal axis) of the ellipse and hyperbola is  $\frac{2b^2}{a}$ .

5. What is the eccentricity of an equilateral hyperbola? *Ans.*  $\sqrt{2}$ .

6. Transform (V) and (VI) to polar coördinates and discuss the resulting equations.

7. Where are the foci and directrices of the circle?

8. What are the equations of the ellipse and hyperbola whose centers are the point  $(\alpha, \beta)$  and whose principal axes are parallel to the  $X$ -axis?

$$\text{Ans. } \frac{(x - \alpha)^2}{a^2} + \frac{(y - \beta)^2}{b^2} = 1; \quad \frac{(x - \alpha)^2}{a^2} - \frac{(y - \beta)^2}{b^2} = 1.$$



**71. Conjugate hyperbolas and asymptotes.** Two hyperbolas are called **conjugate hyperbolas** if the transverse and conjugate axes of one are respectively the conjugate and transverse axes of the other. They will have the same center and their principal axes (p. 149) will be perpendicular.

If the equation of an hyperbola is given in typical form, then *the equation of the conjugate hyperbola is found by changing the signs of the coefficients of  $x^2$  and  $y^2$  in the given equation.*

For if one equation be written in the form (VI) and the other in the form (VIII), then the positive denominator of either is numerically the same as the negative denominator of the other. Hence the transverse axis of either is the conjugate axis of the other.

Thus the loci of the equations

$$(1) \quad 16x^2 - y^2 = 16 \text{ and } -16x^2 + y^2 = 16$$

are conjugate hyperbolas. They may be written

$$\frac{x^2}{1} - \frac{y^2}{16} = 1 \text{ and } -\frac{x^2}{1} + \frac{y^2}{16} = 1.$$

The foci of the first are on the  $X$ -axis, those of the second on the  $Y$ -axis. The transverse axis of the first and the conjugate axis of the second are equal to 2, while the conjugate axis of the first and the transverse axis of the second are equal to 8.

The foci of two conjugate hyperbolas are equally distant from the origin.

For  $c^2$  (Theorems VI and VIII) equals the sum of the squares of the semi-transverse and semi-conjugate axes, and that sum is the same for two conjugate hyperbolas.

Thus in the first of the hyperbolas above  $c^2 = 1 + 16$ , while in the second  $c^2 = 16 + 1$ .

If in one of the typical forms of the equation of an hyperbola we replace the constant term by zero, then the locus of the new equation is a pair of lines (Theorem, p. 59) which are called the **asymptotes** of the hyperbola.

Thus the asymptotes of the hyperbola

$$(2) \quad b^2x^2 - a^2y^2 = a^2b^2$$

are the lines

$$(3) \quad b^2x^2 - a^2y^2 = 0,$$

or

$$(4) \quad bx + ay = 0 \text{ and } bx - ay = 0.$$

Both of these lines pass through the origin, and their slopes are respectively

$$(5) \quad -\frac{b}{a} \text{ and } \frac{b}{a}.$$

An important property of the asymptotes is given by

**Theorem IX.** *The branches of the hyperbola approach its asymptotes as they recede to infinity.*

*Proof.* Let  $P_1(x_1, y_1)$  be a point on either branch of (2) near the first of the asymptotes (4). The distance from this line to  $P_1$  (Fig., p. 167) is (Rule, p. 97)

$$(6) \quad d = \frac{bx_1 + ay_1}{+\sqrt{b^2 + a^2}}.$$

Since  $P_1$  lies on (2),  $b^2x_1^2 - a^2y_1^2 = a^2b^2$ .

$$\text{Factoring,} \quad bx_1 + ay_1 = \frac{a^2b^2}{bx_1 - ay_1}.$$

$$\text{Substituting in (6),} \quad d = \frac{a^2b^2}{+\sqrt{b^2 + a^2}(bx_1 - ay_1)}.$$

As  $P_1$  recedes to infinity,  $x_1$  and  $y_1$  become infinite and  $d$  approaches zero.

For  $bx_1$  and  $ay_1$  cannot cancel, since  $x_1$  and  $y_1$  have opposite signs in the second and fourth quadrants.

Hence the curve approaches closer and closer to its asymptotes.

Q. E. D.

Two conjugate hyperbolas have the same asymptotes.

For if we replace the constant term in both equations by zero, the resulting equations differ only in form and hence have the same loci.

Thus the asymptotes of the conjugate hyperbolas (1) are respectively the loci of

$$16x^2 - y^2 = 0 \text{ and } -16x^2 + y^2 = 0,$$

which are the same.

An hyperbola may be drawn with fair accuracy by the following

*Construction.* Lay off  $OA = OA' = a$  on the axis on which the foci lie, and  $OB = OB' = b$  on the other axis. Draw lines through  $A, A', B, B'$  parallel to the axes, forming a rectangle.\* Draw the

\* An ellipse may be drawn with fair accuracy by inscribing it in such a rectangle.

diagonals of the rectangle and the circumscribed circle. Draw the branches of the hyperbola tangent to the sides of the rectangle at  $A$  and  $A'$  and approaching nearer and nearer to the diagonals. The conjugate hyperbola may be drawn tangent to the sides of the rectangle at  $B$  and  $B'$  and approaching the diagonals. The foci of both are the points in which the circle cuts the axes.

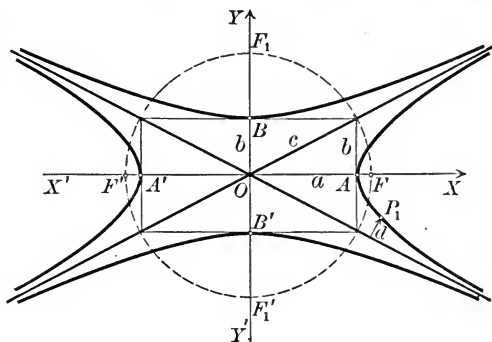

The diagonals will be the asymptotes, because two of the vertices of the rectangle ( $\pm a, \pm b$ ) will lie on each asymptote (4). Half the diagonal will equal  $c$ , the distance from the origin to the foci, because  $c^2 = a^2 + b^2$ .

**72. The equilateral hyperbola referred to its asymptotes.** The equation of the equilateral hyperbola (p. 162) is

(1) 
$$x^2 - y^2 = a^2.$$

Its asymptotes are the lines

$$x - y = 0 \text{ and } x + y = 0.$$

These lines are perpendicular (Corollary III, p. 78), and hence they may be used as coördinate axes.

**Theorem X.** *The equation of an equilateral hyperbola referred to its asymptotes is*

(X) 
$$2xy = a^2.$$

*Proof.* The axes must be rotated through  $-\frac{\pi}{4}$  to coincide with the asymptotes.

Hence we substitute (Theorem II, p. 138)

$$x = \frac{x' + y'}{\sqrt{2}}, \quad y = \frac{-x' + y'}{\sqrt{2}}$$

in (1). This gives

$$\frac{(x' + y')^2}{2} - \frac{(-x' + y')^2}{2} = a^2.$$

Or, reducing and dropping primes,

$$2xy = a^2.$$

Q. E. D.

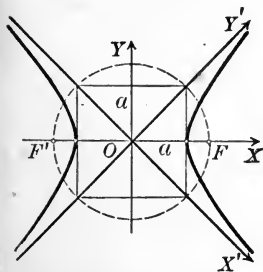

**73. Focal property of central conics.** A line joining a point on a conic to a focus is called a **focal radius**. Two focal radii, one to each focus, may evidently be drawn from any point on a central conic.

**Theorem XI.** *The sum of the focal radii from any point on an ellipse is equal to the major axis  $2a$ .*

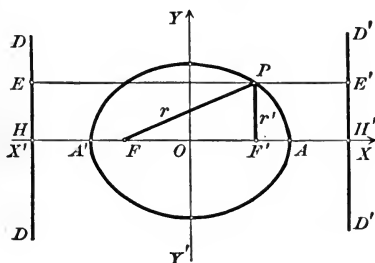

*Proof.* Let  $P$  be any point on the ellipse. By definition (p. 149),

$$r = e \cdot PE, \quad r' = e \cdot PE'.$$

$$\text{Hence } r + r' = e(PE + PE') \\ = e \cdot HH'.$$

$$\text{From (7), p. 161, } e = \frac{c}{a},$$

and from the equations of the directrices (Theorem V),

$$HH' = 2 \frac{a^2}{c}.$$

$$\text{Hence } r + r' = \frac{c}{a} \cdot 2 \frac{a^2}{c} = 2a.$$

Q.E.D.

**Theorem XII.** *The difference of the focal radii from any point on an hyperbola is equal to the transverse axis  $2a$ .*

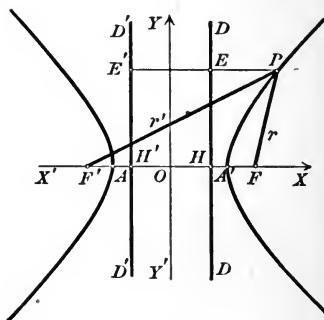

*Proof.* Let  $P$  be any point on the hyperbola. By definition (p. 149),

$$r = e \cdot PE, \quad r' = e \cdot PE'.$$

$$\text{Hence } r' - r = e(PE' - PE) \\ = e \cdot HH'.$$

$$\text{From (8), p. 161, } e = \frac{c}{a},$$

and from the equations of the directrices (Theorem VI),

$$HH' = 2 \frac{a^2}{c}.$$

$$\text{Hence } r' - r = \frac{c}{a} \cdot 2 \frac{a^2}{c} = 2a.$$

Q.E.D.

**74. Mechanical construction of conics.** Theorems XI and XII afford simple methods of drawing ellipses and hyperbolas. Place two tacks in the drawing board at the foci  $F$  and  $F'$  and wind a string about them as indicated.

If the string be held fast at  $A$ , and a pencil be placed in the loop  $FPP'$  and be moved so as to keep the string taut, then  $PF + PF'$  is constant and  $P$  describes an ellipse. If the major axis is to be  $2a$ , then the length of the loop  $FPP'$  must be  $2a$ .

If the pencil be tied to the string at  $P$ , and both strings be pulled in or let out at  $A$  at the same time, then  $PF' - PF$  will be constant and  $P$  will describe an hyperbola. If the transverse axis is to be  $2a$ , the strings must be adjusted at the start so that the difference between  $PF'$  and  $PF$  equals  $2a$ .

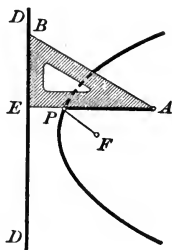
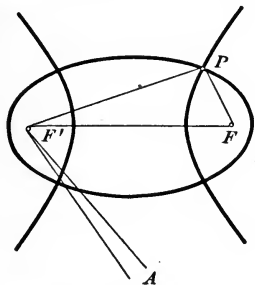

To describe a parabola, place a right triangle with one leg  $EB$  on the directrix  $DD$ . Fasten one end of a string whose length is  $AE$  at the focus  $F$ , and the other end to the triangle at  $A$ . With a pencil at  $P$  keep the string taut. Then  $PF = PE$ ; and as the triangle is moved along  $DD$  the point  $P$  will describe a parabola.

### PROBLEMS

1. Find the equations of the asymptotes and hyperbolas conjugate to the following hyperbolas, and plot.

(a)  $4x^2 - y^2 = 36$ .

(c)  $16x^2 - y^2 + 64 = 0$ .

(b)  $9x^2 - 25y^2 = 100$ .

(d)  $8x^2 - 16y^2 + 25 = 0$ .

2. Prove Theorem IX for the asymptote which passes through the first and third quadrants.

3. If  $e$  and  $e'$  are the eccentricities of two conjugate hyperbolas, then  $\frac{1}{e^2} + \frac{1}{e'^2} = 1$ .

4. The distance from an asymptote of an hyperbola to its foci is numerically equal to  $b$ .

5. The distance from a line through a focus of an hyperbola, perpendicular to an asymptote, to the center is numerically equal to  $a$ .

6. The product of the distances from the asymptotes to any point on the hyperbola is constant.

7. The focal radius of a point  $P_1(x_1, y_1)$  on the parabola  $y^2 = 2px$  is  $\frac{p}{2} + x_1$ .

8. The focal radii of a point  $P_1(x_1, y_1)$  on the ellipse  $b^2x^2 + a^2y^2 = a^2b^2$  are  $r = a - ex_1$  and  $r' = a + ex_1$ .

9. The focal radii of a point on the hyperbola  $b^2x^2 - a^2y^2 = a^2b^2$  are  $r = ex_1 - a$  and  $r' = ex_1 + a$  when  $P_1$  is on the right-hand branch, or  $r = -ex_1 - a$  and  $r' = -ex_1 + a$  when  $P_1$  is on the left-hand branch.

10. The distance from a point on an equilateral hyperbola to the center is a mean proportional between the focal radii of the point.

11. The eccentricity of an hyperbola equals the secant of the inclination of one asymptote.

**75. Types of loci of equations of the second degree.** All of the equations of the conic sections that we have considered are of the second degree. If the axes be moved in any manner, the equation will still be of the second degree (Theorem IV, p. 140), although its form may be altered considerably. We have now to consider the different possible forms of loci of equations of the second degree.

By Theorem VI, p. 145, the term in  $xy$  may be removed by rotating the axes. Hence we only need to consider an equation of the form

$$(1) \quad Ax^2 + Cy^2 + Dx + Ey + F = 0.$$

It is necessary to distinguish two cases.

CASE I. Neither  $A$  nor  $C$  is zero.

CASE II. Either  $A$  or  $C$  is zero.

$A$  and  $C$  cannot both be zero, as then (1) would not be of the second degree.

#### *Case I*

When neither  $A$  nor  $C$  is zero, then  $\Delta = B^2 - 4AC$  is not zero, and hence (Theorem VII, p. 146) we can remove the terms in  $x$  and  $y$  by translating the axes. Then (1) becomes (Corollary I, p. 147)

$$(2) \quad Ax'^2 + Cy'^2 + F' = 0.$$

We distinguish two types of loci according as  $A$  and  $C$  have the same or different signs.

**Elliptic type**,  $A$  and  $C$  have the same sign.

1.  $F' \neq 0$ .<sup>\*</sup> Then (2) may be written

$$\frac{x^2}{\alpha} + \frac{y^2}{\beta} = 1,$$

where  $\alpha = -\frac{F'}{A}$ ,  $\beta = -\frac{F'}{C}$ .

Hence, if the sign of  $F'$  is different from that of  $A$  and  $C$ , the locus is an *ellipse*; but if the sign of  $F'$  is the same as that of  $A$  and  $C$ , there is *no locus*.

2.  $F' = 0$ . The locus is a *point*. It may be regarded as an ellipse whose axes are zero and it is called a *degenerate ellipse*.

**Hyperbolic type**,  $A$  and  $C$  have different signs.

1.  $F' \neq 0$ .<sup>\*</sup> Then (2) may be written

$$\frac{x^2}{\alpha} + \frac{y^2}{\beta} = 1,$$

where  $\alpha = -\frac{F'}{A}$ ,  $\beta = -\frac{F'}{C}$ .

Hence the locus is an *hyperbola* whose foci are on the  $Y$ -axis if the signs of  $F'$  and  $A$  are the same, or on the  $X$ -axis if the signs of  $F'$  and  $C$  are the same.

2.  $F' = 0$ . The locus is a pair of *intersecting lines*. It may be regarded as an hyperbola whose axes are zero and it is called a *degenerate hyperbola*.

### Case II

When either  $A$  or  $C$  is zero the locus is said to belong to the **parabolic type**. We can always suppose  $A = 0$  and  $C \neq 0$ , so that (1) becomes

$$(3) \quad Cy^2 + Dx + Ey + F = 0.$$

For if  $A \neq 0$  and  $C = 0$ , (1) becomes  $Ax^2 + Dx + Ey + F = 0$ . Rotate the axes (Theorem II, p. 138) through  $\frac{\pi}{2}$  by setting  $x = -y'$ ,  $y = x'$ . This equation becomes  $Ay'^2 + Ex' - Dy' + F = 0$ , which is of the form (3).

By translating the axes (3) may be reduced to one of the forms

$$(4) \quad Cy^2 + Dx = 0 \text{ or}$$

$$(5) \quad Cy^2 + F' = 0.$$

For substitute in (3),  $x = x' + h$ ,  $y = y' + k$ .

This gives

$$(6) \quad Cy'^2 + Dx' + 2Ck \left| \begin{array}{l} y' + Ck^2 \\ + Dh \\ + Ek \\ + F' \end{array} \right| = 0.$$

If we determine  $h$  and  $k$  from

$$2Ck + E = 0, \quad Ck^2 + Dh + Ek + F' = 0,$$

then (6) reduces to (4). But if  $D = 0$ , we cannot solve the last equation for  $h$ , so that we cannot always remove the constant term. In this case (6) reduces to (5).

<sup>\*</sup> Read " $F'$  not equal to zero" or " $F'$  different from zero."

Comparing (4) with (III), p. 155, the locus is seen to be a *parabola*. The locus of (5) is the pair of *parallel lines*  $y = \pm \sqrt{-\frac{F'}{C}}$  when  $F'$  and  $C$  have different signs, or the *single line*  $y = 0$  when  $F' = 0$ . If  $F'$  and  $C$  have the same sign, there is *no locus*. When the locus of an equation of the second degree is a pair of parallel lines or a single line it is called a **degenerate parabola**.

We have thus proved

**Theorem XIII.** *The locus of an equation of the second degree is a conic, a point, or a pair of straight lines, which may be coincident. By moving the axes its equation may be reduced to one of the three forms*

$$Ax^2 + Cy^2 + F^* = 0, \quad Cy^2 + Dx = 0, \quad Cy^2 + F^* = 0,$$

where  $A$ ,  $C$ , and  $D$  are different from zero.

**Corollary.** *The locus of an equation in which the term in  $xy$  is lacking,*

$$Ax^2 + Cy^2 + Dx + Ey + F = 0,$$

will belong to

*the parabolic type if  $A = 0$  or  $C = 0$ ,*

*the elliptic type if  $A$  and  $C$  have the same sign,*

*the hyperbolic type if  $A$  and  $C$  have different signs.*

### PROBLEMS

1. To what point is the origin moved to transform (1) into (2)?

$$\text{Ans. } \left( -\frac{D}{2A}, -\frac{E}{2C} \right).$$

2. To what point is the origin moved to transform (3) into (4)? into (5)?

$$\text{Ans. } \left( \frac{E^2 - 4CF}{4CD}, -\frac{E}{2C} \right), \quad \left( 0, -\frac{E}{2C} \right).$$

3. Simplify  $Ax^2 + Dx + Ey + F = 0$  by translating the axes (a) if  $E \neq 0$ , (b) if  $E = 0$ , and find the point to which the origin is moved.

$$\text{Ans. (a) } Ax^2 + Ey = 0, \quad \left( -\frac{D}{2A}, \frac{D^2 - 4AF}{4AE} \right);$$

$$\text{(b) } Ax^2 + F = 0, \quad \left( -\frac{D}{2A}, 0 \right).$$

\* In describing the final *form* of the equation it is unnecessary to indicate by primes what terms are different from those in (1).



4. To what types do the loci of the following equations belong?

(a)  $4x^2 + y^2 - 13x + 7y - 1 = 0$ .

(e)  $x^2 + 7y^2 - 8x + 1 = 0$ .

(b)  $y^2 + 3x - 4y + 9 = 0$ .

(f)  $x^2 + y^2 - 6x + 8y = 0$ .

(c)  $121x^2 - 44y^2 + 68x - 4 = 0$ .

(g)  $3x^2 - 4y^2 - 6y + 9 = 0$ .

(d)  $x^2 + 4y - 3 = 0$ .

(h)  $x^2 - 8x + 9y - 11 = 0$ .

(i) The equations in problem 1, p. 148, which do not contain the  $xy$ -term.

**76. Construction of the locus of an equation of the second degree.** To remove the  $xy$ -term from

$$(1) \quad Ax^2 + Bxy + Cy^2 + Dx + Ey + F = 0$$

it is necessary to rotate the axes through an angle  $\theta$  such that (Theorem VI, p. 145)

$$(2) \quad \tan 2\theta = \frac{B}{A - C},$$

while in the formulas for rotating the axes [(II), p. 138] we need  $\sin \theta$  and  $\cos \theta$ . By 1 and 3, p. 12, we have

$$(3) \quad \cos 2\theta = \pm \frac{1}{\sqrt{1 + \tan^2 2\theta}}.$$

From (2) we can choose  $2\theta$  in the first or second quadrant so the *sign* in (3) must be the same as in (2).  $\theta$  will then be acute; and from 15, p. 13, we have

$$(4) \quad \sin \theta = + \sqrt{\frac{1 - \cos 2\theta}{2}}, \quad \cos \theta = + \sqrt{\frac{1 + \cos 2\theta}{2}}.$$

In simplifying a numerical equation of the form (1) the computation is simplified, if  $\Delta = B^2 - 4AC \neq 0$ , by first removing the terms in  $x$  and  $y$  (Theorem VII, p. 146) and then the  $xy$ -term.

Hence we have the

**Rule to construct the locus of a numerical equation of the second degree.**

*First step.* Compute  $\Delta = B^2 - 4AC$ .

*Second step.* Simplify the equation by

(a) translating and then rotating the axes if  $\Delta \neq 0$ ;

(b) rotating and then translating the axes if  $\Delta = 0$ .

*Third step. Determine the nature of the locus by inspection of the equation (§ 75, p. 170).*

*Fourth step. Plot all of the axes used and the locus.*

In the second step the equations for rotating the axes are found from equations (2), (3), (4), and (II), p. 138. But if the  $xy$ -term is lacking, it is not necessary to rotate the axes. The equations for translating the axes are found by the Rule on p. 141.

**Ex. 1.** Construct and discuss the locus of

$$x^2 + 4xy + 4y^2 + 12x - 6y = 0.$$

*Solution.* First step. Here  $\Delta = 4^2 - 4 \cdot 1 \cdot 4 = 0$ .

Second step. Hence we rotate the axes through an angle  $\theta$  such that, by (2),

$$\tan 2\theta = \frac{4}{1-4} = -\frac{4}{3} \cdot \left( \frac{B}{A-C} \right)$$

Then by (3),  $\cos 2\theta = -\frac{3}{5}$ ,

and by (4),  $\sin \theta = \frac{2}{\sqrt{5}}$  and  $\cos \theta = \frac{1}{\sqrt{5}}$ .

The equations for rotating the axes [(II), p. 138] become

$$(1) \quad x = \frac{x' - 2y'}{\sqrt{5}}, \quad y = \frac{2x' + y'}{\sqrt{5}}.$$

Substituting in the given equation,\* we obtain

$$x'^2 - \frac{6}{\sqrt{5}}y' = 0.$$

It is not necessary to translate the axes.

Third step. This equation may be written

$$x'^2 = \frac{6}{\sqrt{5}}y'.$$

Hence the locus is a parabola for which  $p = \frac{3}{\sqrt{5}}$ , and whose focus is on the  $Y'$ -axis.

\* When  $\Delta = 0$  the terms of the second degree form a perfect square. The work of substitution is simplified if the given equation is first written in the form

$$(x + 2y)^2 + 12x - 6y = 0.$$

It can be shown that when  $\Delta = 0$  the locus is always of the parabolic type.

Fourth step. The figure shows both sets of axes,\* the parabola, its focus and directrix.

In the new coördinates the focus is the point  $(0, \frac{3}{2\sqrt{5}})$  and the directrix is the line  $y' = -\frac{3}{2\sqrt{5}}$  (Theorem IV, p. 155). The old coördinates of the focus may be found by substituting the new coördinates for  $x'$  and  $y'$  in (1), and the equation of the directrix in the old coördinates may be found by solving (1) for  $y'$  and substituting in the equation given above.

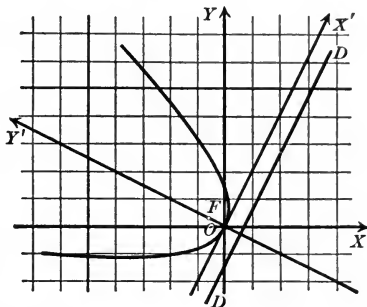

**Ex. 2.** Construct the locus of

$$5x^2 + 6xy + 5y^2 + 22x - 6y + 21 = 0.$$

*Solution.* First step.  $\Delta = 6^2 - 4 \cdot 5 \cdot 5 \neq 0$ .

Second step. Hence we translate the axes first. It is found that the equations for translating the axes are

$$x = x' - 4, \quad y = y' + 3,$$

and that the transformed equation is

$$5x'^2 + 6x'y' + 5y'^2 = 32.$$

From (2) it is seen that the axes must be rotated through  $\frac{\pi}{4}$ . Hence we set

$$x' = \frac{x'' - y''}{\sqrt{2}}, \quad y' = \frac{x'' + y''}{\sqrt{2}};$$

and the final equation is

$$4x''^2 + y''^2 = 16.$$

Third step. The simplified equation may be written

$$\frac{x''^2}{4} + \frac{y''^2}{16} = 1.$$

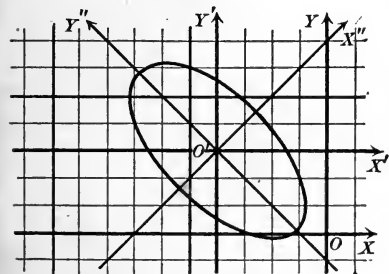

Hence the locus is an ellipse whose major axis is 8, whose minor axis is 4, and whose foci are on the  $Y''$ -axis.

Fourth step. The figure shows the three sets of axes and the ellipse.

\*The inclination of  $OX'$  is  $\theta$ , and hence its slope,  $\tan \theta$ , may be obtained from (4). In this example  $\tan \theta = \frac{\sin \theta}{\cos \theta} = \frac{2}{\sqrt{5}} \div \frac{1}{\sqrt{5}} = 2$ , and the  $X'$ -axis may be constructed by the method given in the footnote, p. 28.

## PROBLEMS

1. Simplify the following equations and construct their loci, foci, and directrices.

(a)  $3x^2 - 4xy + 8x - 1 = 0$ . *Ans.*  $x''^2 - 4y''^2 + 1 = 0$ .

(b)  $4x^2 + 4xy + y^2 + 8x - 16y = 0$ . *Ans.*  $5x'^2 - 8\sqrt{5}y' = 0$ .

(c)  $41x^2 - 24xy + 34y^2 + 25 = 0$ . *Ans.*  $x'^2 + 2y'^2 + 1 = 0$ .

(d)  $17x^2 - 12xy + 8y^2 - 68x + 24y - 12 = 0$ .  
*Ans.*  $x''^2 + 4y''^2 - 16 = 0$ .

(e)  $y^2 + 6x - 6y + 21 = 0$ . *Ans.*  $y'^2 + 6x' = 0$ .

(f)  $x^2 - 6xy + 9y^2 + 4x - 12y + 4 = 0$ . *Ans.*  $y''^2 = 0$ .

(g)  $12xy - 5y^2 + 48y - 36 = 0$ . *Ans.*  $4x''^2 - 9y'' = 36$ .

(h)  $4x^2 - 12xy + 9y^2 + 2x - 3y - 12 = 0$ .  
*Ans.*  $52y''^2 - 49 = 0$ .

(i)  $14x^2 - 4xy + 11y^2 - 88x + 34y + 149 = 0$ .  
*Ans.*  $2x''^2 + 3y''^2 = 0$ .

(j)  $12x^2 + 8xy + 18y^2 + 48x + 16y + 43 = 0$ .  
*Ans.*  $4x^2 + 2y^2 = 1$ .

(k)  $9x^2 + 24xy + 16y^2 - 36x - 48y + 61 = 0$ .  
*Ans.*  $x''^2 + 1 = 0$ .

(l)  $7x^2 + 50xy + 7y^2 = 50$ . *Ans.*  $16x'^2 - 9y'^2 = 25$ .

(m)  $x^2 + 3xy - 3y^2 + 6x = 0$ . *Ans.*  $21x''^2 - 49y''^2 = 72$ .

(n)  $16x^2 - 24xy + 9y^2 - 60x - 80y + 400 = 0$ .  
*Ans.*  $y''^2 - 4x'' = 0$ .

(o)  $95x^2 + 56xy - 10y^2 - 56x + 20y + 194 = 0$ .  
*Ans.*  $6x''^2 - y''^2 + 12 = 0$ .

(p)  $5x^2 - 5xy - 7y^2 - 165x + 1320 = 0$ . *Ans.*  $15x''^2 - 11y''^2 - 330 = 0$ .

**77. Systems of conics.** The purpose of this section is to illustrate by examples and problems the relations between conics and degenerate conics and between conics of different types.

A system of conics of the same type shows how the degenerate conics appear as limiting forms, while a system of conics of different types shows that the parabolic type is intermediate between the elliptic and hyperbolic types.

**Ex. 1.** Discuss the system of conics represented by  $x^2 + 4y^2 = k$ .

*Solution.* Since the coefficients of  $x^2$  and  $y^2$  have the same sign, the locus belongs to the elliptic type (Corollary, p. 172). When  $k$  is positive the locus is an ellipse; when  $k = 0$  the locus is the origin, — a degenerate ellipse; and when  $k$  is negative there is no locus.

In the figure the locus is plotted for  $k = 100, 64, 36, 16, 4, 1, 0$ . It is seen that as  $k$  approaches zero the ellipses become smaller and finally degenerate into a point. As soon as  $k$  becomes negative there is no locus. Hence the

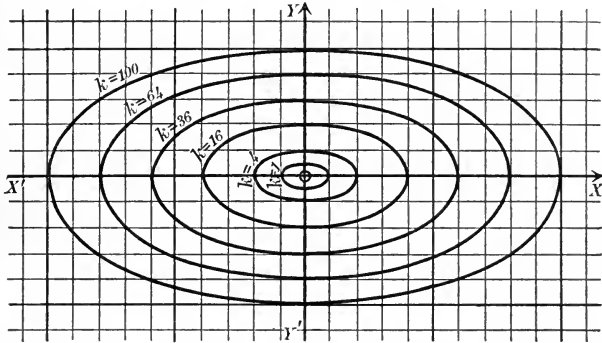

point is a *limiting case* between the cases when the locus is an ellipse and when there is no locus.

**Ex. 2.** Discuss the system of conics represented by  $4x^2 - 16y^2 = k$ .

*Solution.* Since the coefficients of  $x^2$  and  $y^2$  have opposite signs, the locus

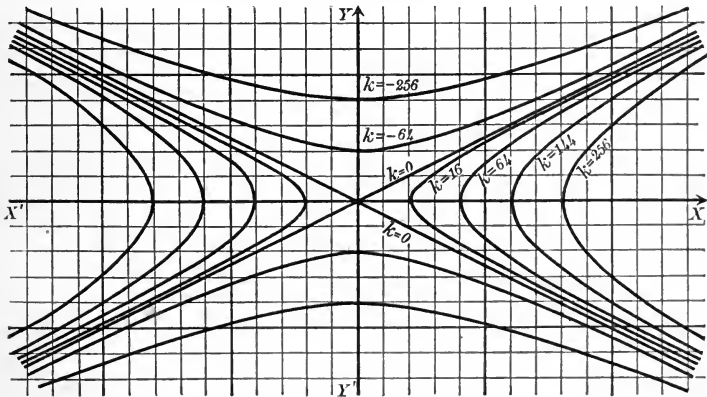

belongs to the hyperbolic type. The hyperbolas will all have the same asymptotes (p. 165), namely, the lines  $x \pm 2y = 0$ . The given equation may be written

$$\frac{x^2}{\frac{k}{4}} - \frac{y^2}{\frac{k}{16}} = 1.$$

The locus is an hyperbola whose foci are on the  $X$ -axis when  $k$  is positive and

on the  $Y$ -axis when  $k$  is negative. For  $k = 0$  the given equation shows that the locus is the pair of asymptotes.

In the figure the locus is plotted for  $k = 256, 144, 64, 16, 0, -64, -256$ . It is seen that as  $k$  approaches zero, whether it is positive or negative, the hyperbolas become more pointed and lie closer to the asymptotes and finally degenerate into the asymptotes. Hence a pair of intersecting lines is a *limiting case* between the cases when the hyperbolas have their foci on the  $X$ -axis and on the  $Y$ -axis.

**Ex. 3.** Discuss the system of conics represented by  $y^2 = 2kx + 16$ .

*Solution.* As only one term of the second degree is present, the locus belongs to the parabolic type (Corollary, p. 172). The given equation may be simplified (Rule, p. 141) by translating the axes to the new origin  $\left(-\frac{8}{k}, 0\right)$ . We thus obtain

$$y'^2 = 2kx'.$$

The locus is therefore a parabola whose vertex is  $\left(-\frac{8}{k}, 0\right)$  and for which  $p = k$ . It will be turned to the right when  $k$  is positive, and to the left when  $k$  is negative. But if  $k = 0$ , the locus is the degenerate parabola  $y = \pm 4$ .

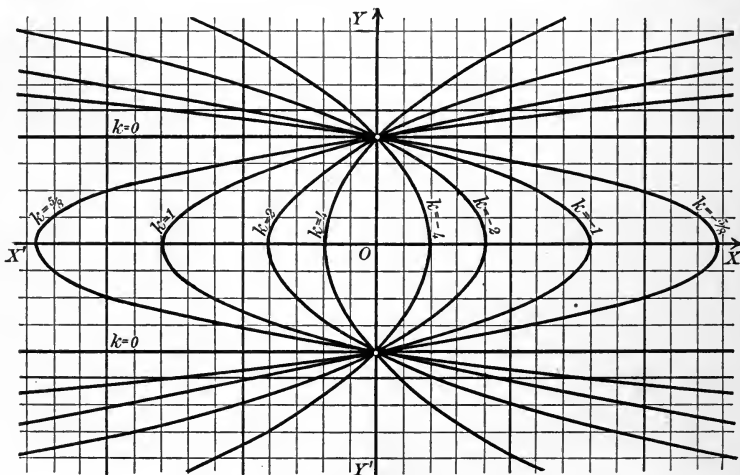

In the figure the locus is plotted for  $k = \pm 4, \pm 2, \pm 1, \pm \frac{1}{2}, 0$ . It is seen that as  $k$  approaches zero, whether it is positive or negative, the vertex recedes from the origin and the parabola lies closer to the lines  $y = \pm 4$  and finally degenerates into these lines. The degenerate parabola consisting of two parallel lines appears as a *limiting case* between the cases when the parabolas are turned to the right and to the left.

## PROBLEMS

1. Plot the following systems of conics.

$$(a) \frac{x^2}{16} + \frac{y^2}{9} = k. \quad (b) y^2 = 2kx. \quad (c) \frac{x^2}{16} - \frac{y^2}{9} = k. \quad (d) x^2 = 2ky - 6.$$

2. Plot the system  $\frac{x^2}{k} + \frac{y^2}{16} = 1$  for positive values of  $k$ . What is the locus if  $k = 16$ ? Show how the foci and directrices behave as  $k$  increases or decreases and approaches 16.

3. Plot the following systems of conics and show that all of the conics of each system have the same foci.

$$(a) \frac{x^2}{16-k} + \frac{y^2}{36-k} = 1. \quad (b) y^2 = 2kx + k^2. \quad (c) \frac{x^2}{64-k} + \frac{y^2}{16-k} = 1.$$

4. Plot and discuss the system  $kx^2 + 2y^2 - 8x = 0$ .

5. Show that all of the conics of the following systems pass through the points of intersection of the conics obtained by setting the parentheses equal to zero. Plot the systems and discuss the loci for the values of  $k$  indicated.

$$(a) (y^2 - 4x) + k(y^2 + 4x) = 0, \quad k = +1, -1. \\ (b) (x^2 + y^2 - 16) + k(x^2 - y^2 - 4) = 0, \quad k = +1, -1, -4. \\ (c) (x^2 + y^2 - 16) + k(x^2 - y^2 - 16) = 0, \quad k = +1, -1.$$

6. Find the equation of the locus of a point  $P$  if the sum of its distances from the points  $(c, 0)$  and  $(-c, 0)$  is  $2a$ .

7. Find the equation of the locus of a point  $P$  if the difference of its distances from the points  $(c, 0)$  and  $(-c, 0)$  is  $2a$ .

8. Show that a conic or degenerate conic may be found which satisfies five conditions, and formulate a rule by which to find its equation. Find the equation of the conics

$$(a) \text{ Passing through } (0, 0), (1, 2), (1, -2), (4, 4), (4, -4). \\ (b) \text{ Passing through } (0, 0), (0, 1), (2, 4), (0, 4), (-1, -2).$$

The circle whose radius is  $a$  and whose center is the center of a central conic is called the **auxiliary circle**.

9. The ordinates of points on an ellipse and the auxiliary circle which have the same abscissas are in the ratio of  $b : a$ .

10. Show that the locus of  $xy + Dx + Ey + F = 0$  is either an equilateral hyperbola whose asymptotes are parallel to the coordinate axes or a pair of perpendicular lines.

## CHAPTER IX

### TANGENTS AND NORMALS

**78. The slope of the tangent.** Let  $P_1$  be a fixed point on a curve  $C$  and let  $P_2$  be a second point on  $C$  near  $P_1$ . Let  $P_2$  approach  $P_1$  by *moving along*  $C$ . Then the limiting position  $P_1T$  of the secant through  $P_1$  and  $P_2$  is called the **tangent** to  $C$  at  $P_1$ .

It is evident that the slope of  $P_1T$  is the limit of the slope of  $P_1P_2$ . The coördinates of  $P_2$  may be written  $(x_1 + h, y_1 + k)$ ,

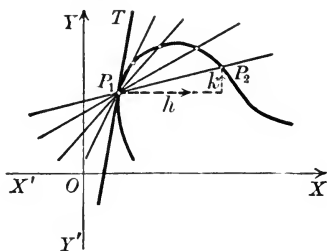

where  $h$  and  $k$  will be positive or negative numbers according to the relative positions of  $P_1$  and  $P_2$ . The slope of the secant through  $P_1$  and  $P_2$  is therefore (Theorem V, p. 28)

$$(1) \quad \frac{y_1 - y_1 - k}{x_1 - x_1 - h} = \frac{k}{h}.$$

As  $P_2$  approaches  $P_1$  both  $h$  and  $k$  approach zero, and hence  $\frac{k}{h}$  approaches  $\frac{0}{0}$ , which may be any number whatever. The actual value of the limit of  $\frac{k}{h}$  may be found in any case from the conditions that  $P_1$  and  $P_2$  lie on  $C$  (Corollary, p. 46), as in the example following.



**Ex. 1.** Find the slope of the tangent to the curve  $C: 8y = x^3$  at any point  $P_1(x_1, y_1)$  on  $C$ .

*Solution.* Let  $P_1(x_1, y_1)$  and  $P_2(x_1 + h, y_1 + k)$  be two points on  $C$ .

Then (Corollary, p. 46)

$$\begin{aligned} (2) \quad & 8y_1 = x_1^3 \\ \text{and} \quad & 8(y_1 + k) = (x_1 + h)^3, \\ \text{or} \quad & \\ (3) \quad & 8y_1 + 8k = x_1^3 + 3x_1^2h + 3x_1h^2 + h^3. \end{aligned}$$

Subtracting (2) from (3), we obtain

$$8k = 3x_1^2h + 3x_1h^2 + h^3.$$

Factoring,  $8k = h(3x_1^2 + 3x_1h + h^2)$ ;

$$\text{and hence} \quad \frac{k}{h} = \frac{3x_1^2 + 3x_1h + h^2}{8}.$$

Then, as  $P_2$  approaches  $P_1$ ,  $h$  and  $k$  approach zero and the

$$\text{limit of } \frac{k}{h} = \text{limit of } \frac{3x_1^2 + 3x_1h + h^2}{8} = \frac{3x_1^2}{8}.$$

Hence the slope  $m$  of the tangent at  $P_1$  is  $m = \frac{3x_1^2}{8}$ .

$C$  is symmetrical with respect to  $O$ , and the tangents at symmetrical points are parallel since only even powers of  $x_1$  and  $y_1$  occur in the value of  $m$ . The tangent at the origin is remarkable in that it crosses the curve.

The method employed in this example is general and may be formulated in the following

**Rule to determine the slope of the tangent to a curve  $C$  at a point  $P_1$  on  $C$ .**

*First step.* Let  $P_1(x_1, y_1)$  and  $P_2(x_1 + h, y_1 + k)$  be two points on  $C$ . Substitute their coördinates in the equation of  $C$  and subtract.

*Second step.* Solve the result of the first step for  $\frac{k}{h}$ ,\* the slope of the secant through  $P_1$  and  $P_2$ .

*Third step.* Find the limit of the result of the second step when  $h$  and  $k$  approach zero. This limit is the required slope.

\*The solution will contain  $h$  and  $k$  separately, so that the equation is not solved in the ordinary sense.

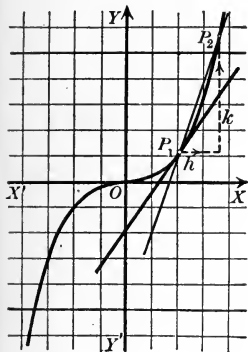

## PROBLEMS

1. Find the slopes of the tangents to the following curves at the points indicated.

- (a)  $y^2 = 8x$ ,  $P_1(2, 4)$ . Ans. 1.  
 (b)  $x^2 + y^2 = 25$ ,  $P_1(3, -4)$ . Ans.  $\frac{3}{4}$ .  
 (c)  $4x^2 + y^2 = 16$ ,  $P_1(0, 4)$ . Ans. 0.  
 (d)  $x^2 - 9y^2 = 81$ ,  $P_1(15, -4)$ . Ans.  $-\frac{5}{8}$ .

2. Find the slopes of the tangents to the following curves at the point  $P_1(x_1, y_1)$ .

- (a)  $y^2 = 6x$ . Ans.  $\frac{3}{y_1}$ .  
 (b)  $16y = x^4$ . Ans.  $\frac{x_1^3}{4}$ .  
 (c)  $x^2 + y^2 = 16$ . Ans.  $-\frac{x_1}{y_1}$ .  
 (d)  $x^2 - y^2 = 4$ . Ans.  $\frac{x_1}{y_1}$ .  
 (e)  $y^2 = x^3 + x^2$ . Ans.  $\frac{3x_1^2 + 2x_1}{2y_1}$ .

**79. Equations of tangent and normal.** We have at once the

*Rule to find the equation of the tangent to a curve  $C$  at a point*

$P_1(x_1, y_1)$  on  $C$ .

*First step.* Find the slope  $m$  of the tangent to  $C$  at  $P_1$  (Rule, p. 181).

*Second step.* Substitute  $x_1, y_1$ , and  $m$  in the point-slope form of the equation of a straight line [(V), p. 86].

*Third step.* Simplify that equation by means of the condition that  $P_1$  lies on  $C$  (Corollary, p. 46).

**Ex. 1.** Find the equation of the tangent to  $C: 8y = x^3$  at  $P_1(x_1, y_1)$ .

*Solution.* First step. From Ex. 1, p. 181, the slope is  $m = \frac{3x_1^2}{8}$ .  
 Second step. Hence the equation of the tangent is

$$y - y_1 = \frac{3x_1^2}{8}(x - x_1),$$

or

$$(1) \quad 3x_1^2x - 8y - 3x_1^3 + 8y_1 = 0.$$

Third step. Since  $P_1$  lies on  $C$ ,  $8y_1 = x_1^3$ .

Substituting in (1), we obtain

$$(2) \quad 3x_1^2x - 8y - 2x_1^3 = 0.$$

The **normal** to a curve  $C$  at a point  $P_1$  on  $C$  is the line through  $P_1$  perpendicular to the tangent to  $C$  at  $P_1$ . Its equation is found from that of the tangent by the Rule on p. 105, using Theorem XII, p. 108.

**Ex. 2.** Find the equation of the normal at  $P_1$  to the curve in Ex. 1.

*Solution.* The equation of any line perpendicular to (2) has the form (Theorem XII, p. 108)

$$(3) \quad 8x + 3x_1^2y + k = 0.$$

If  $P_1$  lies on this line, then (Corollary, p. 46)

$$8x_1 + 3x_1^2y_1 + k = 0,$$

whence

$$k = -8x_1 - 3x_1^2y_1.$$

Substituting in (3), the equation of the normal is

$$8x + 3x_1^2y - 8x_1 - 3x_1^2y_1 = 0.$$

### PROBLEMS

1. Find the equations of the tangents and normals at  $P_1(x_1, y_1)$  to the curves in problem 2, p. 182.

- Ans.* (a)  $y_1y = 3(x + x_1)$ ,  $y_1x + 3y = x_1y_1 + 3y_1$ .  
 (b)  $x_1^3x - 4y = 12y_1$ ,  $4x + x_1^3y = 4x_1 + x_1^3y_1$ .  
 (c)  $x_1x + y_1y = 16$ ,  $y_1x - x_1y = 0$ .  
 (d)  $x_1x - y_1y = 4$ ,  $y_1x + x_1y = 2x_1y_1$ .  
 (e)  $(3x_1^2 + 2x_1)x - 2y_1y - x_1^3 = 0$ ,  $2y_1x + (3x_1^2 + 2x_1)y = 3x_1^2y_1 + 4x_1y_1$ .

2. Find the equations of the tangents and normals to the following curves at the points indicated.

- (a)  $y^2 - 8x + 4y = 0$ ,  $(0, 0)$ . *Ans.*  $2x - y = 0$ ,  $x + 2y = 0$ .  
 (b)  $xy = 4$ ,  $(2, 2)$ . *Ans.*  $x + y = 4$ ,  $x - y = 0$ .  
 (c)  $x^2 - 4y^2 = 25$ ,  $P_1(x_1, y_1)$ . *Ans.*  $x_1x - 4y_1y = 25$ ,  $4y_1x + x_1y = 5x_1y_1$ .  
 (d)  $x^2 + 2xy = 4$ ,  $P_1(x_1, y_1)$ .  
*Ans.*  $(x_1 + y_1)x + x_1y = 4$ ,  $x_1x - (x_1 + y_1)y = x_1^2 - x_1y_1 - y_1^2$ .  
 (e)  $y^2 = 2px$ ,  $P_1(x_1, y_1)$ . *Ans.*  $y_1y = p(x + x_1)$ ,  $y_1x + py = x_1y_1 + py_1$ .  
 (f)  $b^2x^2 - a^2y^2 = a^2b^2$ ,  $P_1(x_1, y_1)$ .  
*Ans.*  $b^2x_1x - a^2y_1y = a^2b^2$ ,  $a^2y_1x + b^2x_1y = (a^2 + b^2)x_1y_1$ .  
 (g)  $x^2 - y^2 + x^3 = 0$ ,  $(0, 0)$ . *Ans.*  $y = \pm x$ ,  $x = \mp y$ .

### 80. Equations of tangents and normals to the conic sections.

**Theorem I.** *The equation of the tangent to the circle*

$$C: x^2 + y^2 = r^2$$

at the point  $P_1(x_1, y_1)$  on  $C$  is

$$(I) \quad x_1x + y_1y = r^2.$$

*Proof.* Let  $P_1(x_1, y_1)$  and  $P_2(x_1 + h, y_1 + k)$  be two points on the circle  $C$ .

Then (Corollary, p. 46)

$$(1) \quad x_1^2 + y_1^2 = r^2$$

$$\text{and} \quad (x_1 + h)^2 + (y_1 + k)^2 = r^2,$$

or

$$(2) \quad x_1^2 + 2x_1h + h^2 + y_1^2 + 2y_1k + k^2 = r^2.$$

Subtracting (1) from (2), we have

$$2x_1h + h^2 + 2y_1k + k^2 = 0.$$

Transposing and factoring, this becomes

$$k(2y_1 + k) = -h(2x_1 + h),$$

whence

$$\frac{k}{h} = -\frac{2x_1 + h}{2y_1 + k}$$

is the slope of the secant through  $P_1$  and  $P_2$ .

Letting  $P_2$  approach  $P_1$ ,  $h$  and  $k$  approach zero, so that  $m$ , the slope of the tangent at  $P_1$ , is

$$m = \text{limit of } -\frac{2x_1 + h}{2y_1 + k} = -\frac{x_1}{y_1}.$$

The equation of the tangent at  $P_1$  is then (Theorem V, p. 86)

$$y - y_1 = -\frac{x_1}{y_1}(x - x_1),$$

or

$$x_1x + y_1y = x_1^2 + y_1^2.$$

But by (1),

$$x_1^2 + y_1^2 = r^2,$$

so that the required equation is

$$x_1x + y_1y = r^2.$$

Q.E.D.

In like manner we may prove the following theorems.

**Theorem II.** *The equation of the tangent at  $P_1(x_1, y_1)$  to the*

*ellipse*  $b^2x^2 + a^2y^2 = a^2b^2$  is  $b^2x_1x + a^2y_1y = a^2b^2$ ;

*hyperbola*  $b^2x^2 - a^2y^2 = a^2b^2$  is  $b^2x_1x - a^2y_1y = a^2b^2$ ;

*parabola*  $y^2 = 2px$  is  $y_1y = p(x + x_1)$ .

**Theorem III.** *The equation of the tangent to the locus of*

$$Ax^2 + Bxy + Cy^2 + Dx + Ey + F = 0$$

*at the point  $P_1(x_1, y_1)$  on the locus is*

$$Ax_1x + B \frac{y_1x + x_1y}{2} + Cy_1y + D \frac{x + x_1}{2} + E \frac{y + y_1}{2} + F = 0.$$

Theorem III may be stated in the form of the

**Rule** *to write the equation of the tangent at  $P_1(x_1, y_1)$  to the locus of an equation of the second degree.*

*First step.* *Substitute  $x_1x$  and  $y_1y$  for  $x^2$  and  $y^2$ ,  $\frac{y_1x + x_1y}{2}$  for  $xy$ , and  $\frac{x + x_1}{2}$  and  $\frac{y + y_1}{2}$  for  $x$  and  $y$  in the given equation.*

*Second step.* *Substitute the numerical values of  $x_1$  and  $y_1$ , if given, in the result of the first step. The result is the required equation.*

From Theorem II, by the method on p. 183, we obtain

**Theorem IV.** *The equation of the normal at  $P_1(x_1, y_1)$  to the*

<i>ellipse</i>	$b^2x^2 + a^2y^2 = a^2b^2$ is	$a^2y_1x - b^2x_1y = (a^2 - b^2)x_1y_1$ ;
<i>hyperbola</i>	$b^2x^2 - a^2y^2 = a^2b^2$ is	$a^2y_1x + b^2x_1y = (a^2 + b^2)x_1y_1$ ;
<i>parabola</i>	$y^2 = 2px$ is	$y_1x + py = x_1y_1 + py_1$ .

### PROBLEMS

1. Find the equations of the tangents and normals to the following conics at the points indicated.

(a)  $3x^2 - 10y^2 = 17$ , (3, 1).

(c)  $2x^2 - y^2 = 14$ , (3, -2).

(b)  $y^2 = 4x$ , (9, -6).

(d)  $x^2 + 5y^2 = 14$ , (3, 1).

(e)  $x^2 - xy + 2x - 7 = 0$ , (3, 2).

(f)  $xy - y^2 + 6x + 8y - 6 = 0$ , (-1, 4).

The directed lengths on the tangent and normal from the point of contact to the  $X$ -axis are called the **length of the tangent** and the **length of the normal** respectively. Their projections on the  $X$ -axis are known as the **subtangent** and **subnormal**.

2. Find the subtangents and subnormals in (a), (b), (c), and (d), problem 1.

*Ans.* (a)  $-\frac{10}{9}, \frac{9}{10}$ ; (b)  $-18, 2$ ; (c)  $-\frac{2}{3}, 6$ ; (d)  $\frac{5}{3}, -\frac{5}{3}$ .

3. Find the lengths of the tangents and normals in (a), (b), (c), and (d), problem 1.

*Ans.* (a)  $\frac{1}{3}\sqrt{181}, \frac{1}{10}\sqrt{181}$ ; (b)  $6\sqrt{10}, 2\sqrt{10}$ ;  
(c)  $\frac{2}{3}\sqrt{10}, 2\sqrt{10}$ ; (d)  $\frac{1}{3}\sqrt{34}, \frac{1}{3}\sqrt{34}$ .

4. Find the subtangents and subnormals of (a) the ellipse, (b) the hyperbola, (c) the parabola.

$$\text{Ans. (a) } \frac{a^2 - x_1^2}{x_1}, -\frac{b^2}{a^2}x_1; \text{ (b) } \frac{a^2 - x_1^2}{x_1}, \frac{b^2}{a^2}x_1; \text{ (c) } -2x_1, p.$$

5. Show how to draw the tangent to a parabola by means of the subnormal or subtangent.

6. Prove that a point  $P_1$  on a parabola and the intersections of the tangent and normal to the parabola at  $P_1$  with the axis are equally distant from the focus.

7. Show how to draw a tangent to a parabola by means of problem 6.

8. The normal to a circle passes through the center.

9. If the normal to an ellipse passes through the center, the ellipse is a circle.

10. The distance from a tangent to a parabola to the focus is half the length of the normal drawn at the point of contact.

11. Find the equation of the tangent at a vertex to (a) the parabola; (b) the ellipse; (c) the hyperbola.

12. Find the subnormal of a point  $P_1$  on an equilateral hyperbola.

$$\text{Ans. } x_1.$$

13. In an equilateral hyperbola the length of the normal at  $P_1$  is equal to the distance from the origin to  $P_1$ .

### 81. Tangents to a curve from a point not on the curve.

Ex. 1. Find the equations of the tangents to the parabola  $y^2 = 4x$  which pass through  $P_2(-3, -2)$ .

*Solution.* Let the point of contact of a line drawn through  $P_2$  tangent to the parabola be  $P_1$ . Then by Theorem III the equation of that line is

$$(1) \quad y_1y = 2x + 2x_1.$$

Since  $P_2$  lies on this line (Corollary, p. 46),

$$(2) \quad -2y_1 = -6 + 2x_1;$$

and since  $P_1$  lies on the parabola,

$$(3) \quad y_1^2 = 4x_1.$$

The coordinates of  $P_1$ , the point of contact, must satisfy (2) and (3). Solving them, we find that  $P_1$  may be either of the points (1, 2) or (9, -6).

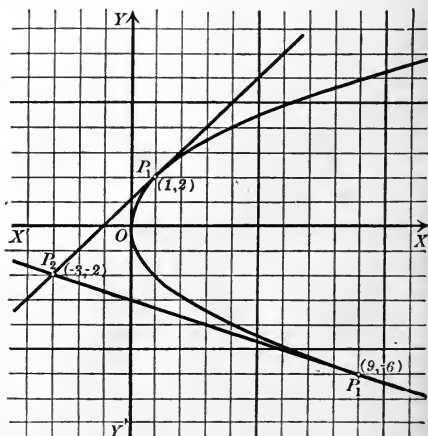



### 82. Properties of tangents and normals to conics.

**Theorem V.** *If a point moves off to infinity on the parabola  $y^2 = 2px$ , the tangent at that point approaches parallelism with the  $X$ -axis.*

*Proof.* The equation of the tangent at the point  $P_1(x_1, y_1)$  is (Theorem II, p. 184)

$$y_1y = px + px_1.$$

Its slope is (Corollary I, p. 77)

$$m = \frac{p}{y_1}.$$

As  $P_1$  recedes to infinity  $y_1$  becomes infinite, and hence  $m$  approaches zero, that is, the tangent approaches parallelism with the  $X$ -axis. Q. E. D.

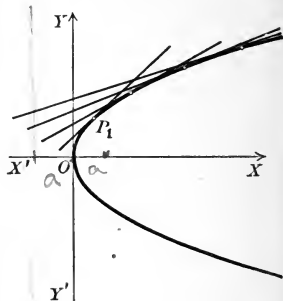

**Theorem VI.** *If a point moves off to infinity on the hyperbola*

$$b^2x^2 - a^2y^2 = a^2b^2,$$

*the tangent at that point approaches coincidence with an asymptote.*

*Proof.* The equation of the tangent at the point  $P_1(x_1, y_1)$  is (Theorem II, p. 184)

$$(1) \quad b^2x_1x - a^2y_1y = a^2b^2.$$

Its slope is (Corollary I, p. 77)  $m = \frac{b^2x_1}{a^2y_1}$ .

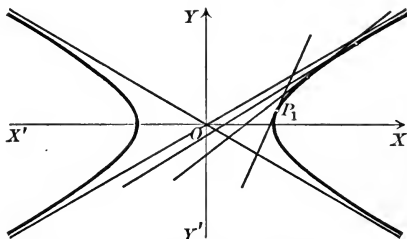

As  $P_1$  recedes to infinity  $x_1$  and  $y_1$  become infinite and  $m$  has the indeterminate form  $\frac{\infty}{\infty}$ .

But since  $P_1$  lies on the hyperbola,

$$b^2x_1^2 - a^2y_1^2 = a^2b^2.$$

Dividing by  $a^2y_1^2$ , transposing, and extracting the square root,

$$\frac{bx_1}{ay_1} = \pm \sqrt{\frac{b^2}{y_1^2} + 1}.$$

Multiplying by  $\frac{b}{a}$ ,  $m = \frac{b^2x_1}{a^2y_1} = \pm \frac{b}{a} \sqrt{\frac{b^2}{y_1^2} + 1}.$



From this form of  $m$  we see that as  $y_1$  becomes infinite  $m$  approaches  $\pm \frac{b}{a}$ , the slopes of the asymptotes [(5), p. 166], as a limit. The intercepts of (1) are  $\frac{a^2}{x_1}$  and  $-\frac{b^2}{y_1}$ . As their limits are zero the limiting position of the tangent will pass through the origin. Hence the tangent at  $P_1$  approaches coincidence with an asymptote. Q. E. D.

These theorems show an essential distinction between the form of the parabola and that of the right-hand branch of the hyperbola.

**Theorem VII.** *The tangent and normal to an ellipse bisect respectively the external and internal angles formed by the focal radii of the point of contact.\**

*Proof.* The equation of the lines joining  $P_1(x_1, y_1)$  on the ellipse

$$b^2x^2 + a^2y^2 = a^2b^2$$

to the focus  $F'(c, 0)$  (Theorem V, p. 161) is (Theorem VII, p. 88)

$$y_1x + (c - x_1)y - cy_1 = 0,$$

and the equation of  $P_1F'$  is

$$y_1x - (c + x_1)y + cy_1 = 0.$$

The equation of the tangent  $AB$  is (Theorem II, p. 184),

$$b^2x_1x + a^2y_1y = a^2b^2.$$

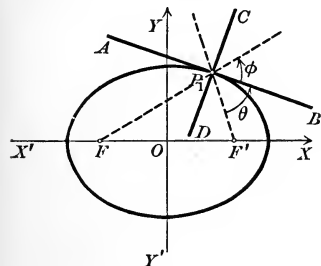

We shall show that the angle  $\theta$  which  $AB$  makes with  $P_1F'$  equals the angle  $\phi$  which  $P_1F$  makes with  $AB$ .

By Theorem X, p. 100,

$$\tan \theta = \frac{a^2y_1^2 - b^2cx_1 + b^2x_1^2}{b^2x_1y_1 + a^2cy_1 - a^2x_1y_1} = \frac{(a^2y_1^2 + b^2x_1^2) - b^2cx_1}{a^2cy_1 - (a^2 - b^2)x_1y_1}.$$

But since  $P_1$  lies on the ellipse,

$$a^2y_1^2 + b^2x_1^2 = a^2b^2,$$

and (Theorem V, p. 161)

$$a^2 - b^2 = c^2.$$

$$\text{Hence } \tan \theta = \frac{a^2b^2 - b^2cx_1}{a^2cy_1 - c^2x_1y_1} = \frac{b^2(a^2 - cx_1)}{cy_1(a^2 - cx_1)} = \frac{b^2}{cy_1}.$$

In like manner

$$\begin{aligned} \tan \phi &= \frac{-b^2cx_1 - b^2x_1^2 - a^2y_1^2}{b^2x_1y_1 - a^2cy_1 - a^2x_1y_1} = \frac{(b^2x_1^2 + a^2y_1^2) + b^2cx_1}{a^2cy_1 + (a^2 - b^2)x_1y_1} \\ &= \frac{a^2b^2 + b^2cx_1}{a^2cy_1 + c^2x_1y_1} = \frac{b^2}{cy_1}. \end{aligned}$$

\*This theorem finds application in the so-called whispering galleries.

Hence  $\tan \theta = \tan \phi$ ; and since  $\theta$  and  $\phi$  are both less than  $\pi$ ,  $\theta = \phi$ . That is,  $AB$  bisects the external angle of  $FP_1$  and  $F'P_1$ , and hence, also,  $CD$  bisects the internal angle. Q.E.D.

In like manner we may prove the following theorems.

**Theorem VIII.** *The tangent and normal to an hyperbola bisect respectively the internal and external angles formed by the focal radii of the point of contact.*

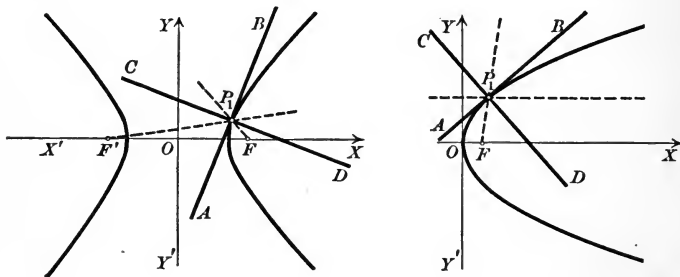

**Theorem IX.** *The tangent and normal to a parabola bisect respectively the internal and external angles formed by the focal radius of the point of contact and the line through that point parallel to the axis.\**

These theorems give rules for constructing the tangent and normal to a conic by means of ruler and compasses.

*Construction.* To construct the tangent and normal to an ellipse or hyperbola at any point, join that point to the foci and bisect the angles formed by these lines. To construct the tangent and normal to a parabola at any point, draw lines through it to the focus and parallel to the axis, and bisect the angles formed by these lines.

The angle which one curve makes with a second is the angle which the tangent to the first makes with the tangent to the second if the tangents are drawn at a point of intersection.

**Theorem X.** *Confocal ellipses and hyperbolas intersect at right angles.*

*Proof.* Let

$$(2) \quad \frac{x^2}{a^2} + \frac{y^2}{b^2} = 1 \quad \text{and} \quad \frac{x^2}{a'^2} - \frac{y^2}{b'^2} = 1$$

be an ellipse and hyperbola with the same foci. Then

$$(3) \quad a^2 - b^2 = a'^2 + b'^2.$$

For if the foci are  $(\pm c, 0)$ , then in the ellipse  $c^2 = a^2 - b^2$  and in the hyperbola  $c^2 = a'^2 + b'^2$  (Theorems V and VI, p. 161).

\* This theorem finds application in reflectors for lights.

The equations of the tangents to (2) at a point of intersection  $P_1(x_1, y_1)$  are (Rule, p. 185)

$$(4) \quad \frac{x_1x}{a^2} + \frac{y_1y}{b^2} = 1 \text{ and } \frac{x_1x}{a'^2} - \frac{y_1y}{b'^2} = 1.$$

It is to be proved that the lines (4) are perpendicular, that is (Corollary III, p. 78), that

$$(5) \quad \frac{x_1^2}{a^2a'^2} - \frac{y_1^2}{b^2b'^2} = 0.$$

Since  $P_1$  lies on both curves (2), we have

$$\frac{x_1^2}{a^2} + \frac{y_1^2}{b^2} = 1 \text{ and } \frac{x_1^2}{a'^2} - \frac{y_1^2}{b'^2} = 1.$$

Subtracting these equations, we obtain

$$(6) \quad \frac{(a^2 - a'^2)x_1^2}{a^2a'^2} - \frac{(b^2 + b'^2)y_1^2}{b^2b'^2} = 0.$$

But from (3),  $a^2 - a'^2 = b^2 + b'^2$ ,

and hence (6) reduces to (5) and the lines (4) are perpendicular. Q. E. D.

In like manner we prove

**Theorem XI.** *Two parabolas with the same focus and axis which are turned in opposite directions intersect at right angles.*

Hence the confocal systems in problem 3, p. 179, are such that the two curves of the system through any point intersect at right angles.

### PROBLEMS

1. Tangents to an ellipse and its auxiliary circle (p. 179) at points with the same abscissa intersect on the  $X$ -axis.
2. The point of contact of a tangent to an hyperbola is midway between the points in which the tangent meets the asymptotes.
3. The foot of the perpendicular from the focus of a parabola to a tangent lies on the tangent at the vertex.
4. The foot of the perpendicular from a focus of a central conic to a tangent lies on the auxiliary circle (p. 179).
5. Tangents to a parabola from a point on the directrix are perpendicular to each other.
6. Tangents to a parabola at the extremities of a chord which pass through the focus are perpendicular to each other.
7. The ordinate of the point of intersection of the directrix of a parabola and the line through the focus perpendicular to a tangent is the same as that of the point of contact.

8. How may problem 7 be used to draw a tangent to a parabola?

9. The line drawn perpendicular to a tangent to a central conic from a focus and the line passing through the center and the point of contact intersect on the corresponding directrix.

10. The angle which one tangent to a parabola makes with a second is half the angle which the focal radius drawn to the point of contact of the first makes with that drawn to the point of contact of the second.

11. The product of the distances from a tangent to a central conic to the foci is constant.

12. Tangents to any conic at the ends of the latus rectum (double chord through the focus perpendicular to the principal axis) pass through the intersection of the directrix and principal axis.

13. Tangents to a parabola at the extremities of the latus rectum are perpendicular.

14. The equation of the parabola referred to the tangents in problem 13 is

$$x^2 - 2xy + y^2 - 2\sqrt{2}p(x+y) + 2p^2 = 0,$$

or (compare p. 10)  $x^{\frac{1}{2}} + y^{\frac{1}{2}} = \sqrt{p\sqrt{2}}.$

15. The area of the triangle formed by a tangent to an hyperbola and the asymptotes is constant.

16. The area of the parallelogram formed by the asymptotes of an hyperbola and lines drawn through a point on the hyperbola parallel to the asymptotes is constant.

17. Find the length of the tangent to a parabola at an extremity of the latus rectum and restate the equation of the parabola in problem 14 in terms of this length.

**83. Tangent in terms of its slope.** The coordinates of the points of intersection of a line and conic are found by solving their equations (Rule, p. 69), which are of the first and second degrees respectively. To solve their equations we eliminate  $x$  or  $y$ ,\* as may be more convenient, and thus obtain an equation of one of the forms

$$(1) \quad Ay^2 + By + C = 0, \quad Ax^2 + Bx + C = 0.$$

If the discriminant  $\Delta = B^2 - 4AC$  is zero, the roots of (1) are real and equal (Theorem II, p. 3), and hence the points of intersection of the line and conic will coincide, that is, the line is

\* If one variable is lacking in either equation, we usually solve that equation for the other variable. But for our purposes we always eliminate the variable which occurs in both equations.

tangent to the conic. The equation obtained by setting the discriminant equal to zero is called the **condition for tangency**. Hence the condition for tangency of a line and conic is found by eliminating either  $x$  or  $y$  from their equations and setting the resulting quadratic equal to zero.

**Ex. 1.** Find the condition for tangency of the line  $\frac{x}{a} + \frac{y}{b} = 1$  and the parabola  $y^2 = 2px$ .

*Solution.* Eliminating  $x$  by solving the first equation for  $x$  and substituting in the second, we get

$$by^2 + 2apy - 2abp = 0.$$

The discriminant of this quadratic is

$$\Delta = (2ap)^2 - 4b(-2abp) = 4ap(ap + 2b^2).$$

Hence the condition for tangency is

$$4ap(ap + 2b^2) = 0 \text{ or } ap(ap + 2b^2) = 0.$$

**Ex. 2.** Find the equations of the lines with the slope  $\frac{1}{2}$  which are tangent to the hyperbola  $x^2 - 6y^2 + 12y - 18 = 0$  and find the points of tangency.

*Solution.* The lines of the system

$$(1) \quad y = \frac{1}{2}x + k$$

have the slope  $\frac{1}{2}$  (Theorem I, p. 51).

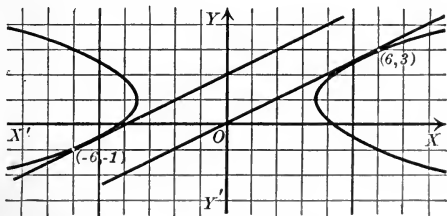

Solving (1) for  $x$  and substituting in the given equation,

$$(2) \quad y^2 + (4k - 6)y + 9 - 2k^2 = 0.$$

Hence the condition for tangency is

$$(4k - 6)^2 - 4(9 - 2k^2) = 0.$$

Solving this equation,  $k = 0$  or  $2$ .

Substituting in (1), we get the required equations, namely,

$$(3) \quad x - 2y = 0, \quad x - 2y + 4 = 0.$$

To find the points of tangency we substitute each value of  $k$  in (2), which then assumes the second form of (7), p. 4, namely,

$$\text{if } k = 0, (2) \text{ becomes } (y - 3)^2 = 0; \therefore y = 3;$$

$$\text{if } k = 2, (2) \text{ becomes } (y + 1)^2 = 0; \therefore y = -1.$$

Hence 3 and  $-1$  are the ordinates of the points of contact. Then, from (1),

if  $k = 0$  and  $y = 3$ , we have  $x = 6$ ;

if  $k = 2$  and  $y = -1$ , we have  $x = -6$ .

Hence, if  $k = 0$ , the point of contact is  $(6, 3)$ ;

if  $k = 2$ , the point of contact is  $(-6, -1)$ .

The points of contact may also be found by solving each of equations (3) with the given equation.

The method of obtaining equations (3) may be summed up in the

**Rule to find the equation of a tangent in terms of its slope  $m$ .**

*First step.* Find the condition for tangency of the line  $y = mx + k$  and the given conic.

*Second step.* Solve the equation found in the second step for  $k$  and substitute the values found in  $y = mx + k$ . The equations obtained are those required.

By means of this Rule we may prove

**Theorem XII.** The equation of a tangent in terms of its slope  $m$  to the

circle  $x^2 + y^2 = r^2$  is  $y = mx \pm r \sqrt{1 + m^2}$ ;

ellipse  $b^2x^2 + a^2y^2 = a^2b^2$  is  $y = mx \pm \sqrt{a^2m^2 + b^2}$ ;

hyperbola  $b^2x^2 - a^2y^2 = a^2b^2$  is  $y = mx \pm \sqrt{a^2m^2 - b^2}$ ;

parabola  $y^2 = 2px$  is  $y = mx + \frac{p}{2m}$ .

### PROBLEMS

1. Determine the condition for tangency of the loci of the following equations.

(a)  $4x^2 + y^2 - 4x - 8 = 0, y = 2x + k.$  *Ans.*  $k^2 + 2k - 17 = 0.$

(b)  $x^2 + y^2 = r^2, 4y - 3x = 4k.$  *Ans.*  $16k^2 = 25r^2.$

(c)\*  $\frac{x^2}{a^2} + \frac{y^2}{b^2} = 1, \frac{x}{\alpha} + \frac{y}{\beta} = 1.$  *Ans.*  $\frac{a^2}{\alpha^2} + \frac{b^2}{\beta^2} = 1.$

(d)\*  $\frac{x^2}{a^2} - \frac{y^2}{b^2} = 1, \frac{x}{\alpha} + \frac{y}{\beta} = 1.$  *Ans.*  $\frac{a^2}{\alpha^2} - \frac{b^2}{\beta^2} = 1.$

\* In these problems it is assumed that the constants involved are not zero.

2. Find the equations of the tangents to the following conics which satisfy the condition indicated, and their points of contact. Verify the latter approximately by constructing the figure.

- (a)  $y^2 = 4x$ , slope =  $\frac{1}{2}$ . *Ans.*  $x - 2y + 4 = 0$ .
- (b)  $x^2 + y^2 = 16$ , slope =  $-\frac{4}{3}$ . *Ans.*  $5x + 3y \pm 20 = 0$ .
- (c)  $9x^2 + 16y^2 = 144$ , slope =  $-\frac{1}{4}$ . *Ans.*  $x + 4y \pm 4\sqrt{10} = 0$ .
- (d)  $x^2 - 4y^2 = 36$ , perpendicular to  $6x - 4y + 9 = 0$ .  
*Ans.*  $2x + 3y \pm 3\sqrt{7} = 0$ .
- (e)  $x^2 + 2y^2 - x + y = 0$ , slope =  $-1$ . *Ans.*  $x + y = 1, 2x + 2y + 1 = 0$ .
- (f)  $xy + y^2 - 4x + 8y = 0$ , parallel to  $2x - 4y = 7$ .  
*Ans.*  $x = 2y, x - 2y + 48 = 0$ .
- (g)  $x^2 + 2xy + y^2 + 8x - 6y = 0$ , slope =  $\frac{4}{3}$ .  
*Ans.*  $4x - 3y = 0$ .
- (h)  $x^2 + 2xy - 4x + 2y = 0$ , slope =  $2$ .  
*Ans.*  $y = 2x, 2x - y + 10 = 0$ .

3. Find the equations of the common tangents to the following pairs of conics. Construct the figure in each case.

- (a)  $y^2 = 5x, 9x^2 + 9y^2 = 16$ . *Ans.*  $9x \pm 12y + 20 = 0$ .
- (b)  $9x^2 + 16y^2 = 144, 7x^2 - 32y^2 = 224$ . *Ans.*  $\pm x - y \pm 5 = 0$ .
- (c)  $x^2 + y^2 = 49, x^2 + y^2 - 20y + 99 = 0$ .  
*Ans.*  $\pm 4x - 3y + 35 = 0, \pm 3x - 4y + 35 = 0$ .

*Hint.* Find the equations of a tangent to each conic in terms of its slope and then determine the slope so that the two lines coincide (Theorem III, p. 79).

4. Two tangents, one tangent, or no tangent can be drawn from a point  $P_1(x_1, y_1)$  to the locus of

- (a)  $y^2 = 2px$  according as  $y_1^2 - 2px_1$  is positive, zero, or negative.
- (b)  $b^2x^2 + a^2y^2 = a^2b^2$  according as  $b^2x_1^2 + a^2y_1^2 - a^2b^2$  is positive, zero, or negative.
- (c)  $b^2x^2 - a^2y^2 = a^2b^2$  according as  $b^2x_1^2 - a^2y_1^2 - a^2b^2$  is negative, zero, or positive.

5. Two perpendicular tangents to

- (a) a parabola intersect on the directrix.
- (b) an ellipse intersect on the circle  $x^2 + y^2 = a^2 + b^2$ .
- (c) an hyperbola intersect on the circle  $x^2 + y^2 = a^2 - b^2$ .

## CHAPTER X

### CARTESIAN COÖRDINATES IN SPACE

**84. Cartesian coördinates.** The foundation of Plane Analytic Geometry lies in the possibility of determining a point in the plane by a pair of real numbers  $(x, y)$  (p. 18). The study of Solid Analytic Geometry is based on the determination of a point in space by a set of *three* real numbers  $x, y,$  and  $z$ . This determination is accomplished as follows :

Let there be given three mutually perpendicular planes intersecting in the lines  $XX', YY',$  and  $ZZ'$  which will also be mutually perpendicular. These three planes are called the **coördinate planes** and may be distinguished as the  $XY$ -plane, the  $YZ$ -plane, and the  $ZX$ -plane. Their lines of intersection are called the **axes of coördinates**, and the positive directions on them are indicated by the arrowheads.\* The point of intersection of the coördinate planes is called the **origin**.

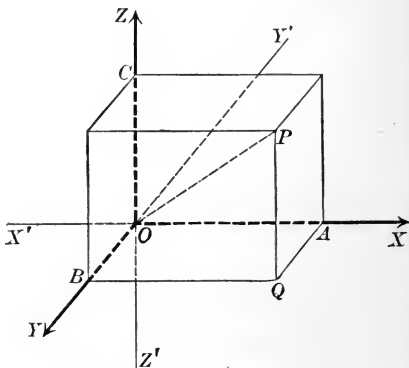

Let  $P$  be any point in space and let three planes be drawn through  $P$  parallel to the coördinate planes and cutting the axes at  $A, B,$  and  $C$ . Then the three numbers  $OA = x, OB = y,$  and  $OC = z$  are called the **rectangular coördinates** of  $P$ .

\*  $XX'$  and  $ZZ'$  are supposed to be in the plane of the paper, the positive direction on  $XX'$  being to the *right*, that on  $ZZ'$  being *upward*.  $YY'$  is supposed to be perpendicular to the plane of the paper, the positive direction being *in front* of the paper, that is, from the plane of the paper toward the reader.



Any point  $P$  in space determines three numbers, the coördinates of  $P$ . Conversely, given any three real numbers  $x$ ,  $y$ , and  $z$ , a point  $P$  in space may always be constructed whose coördinates are  $x$ ,  $y$ , and  $z$ . For if we lay off  $OA = x$ ,  $OB = y$ , and  $OC = z$ , and draw planes through  $A$ ,  $B$ , and  $C$  parallel to the coördinate planes, they will intersect in such a point  $P$ . Hence

*Every point determines three real numbers, and conversely, three real numbers determine a point.*

The coördinates of  $P$  are written  $(x, y, z)$ , and the symbol  $P(x, y, z)$  is to be read, "The point  $P$  whose coördinates are  $x$ ,  $y$ , and  $z$ ."

The coördinate planes divide all space into eight parts called **octants**, designated by  $O\text{-}XYZ$ ,  $O\text{-}X'YZ$ , etc. The signs of the coördinates of a point in any octant may be determined by the

**Rule for signs.**

*$x$  is positive or negative according as  $P$  lies to the right or left of the  $YZ$ -plane.*

*$y$  is positive or negative according as  $P$  lies in front or in back of the  $ZX$ -plane.*

*$z$  is positive or negative according as  $P$  lies above or below the  $XY$ -plane.*

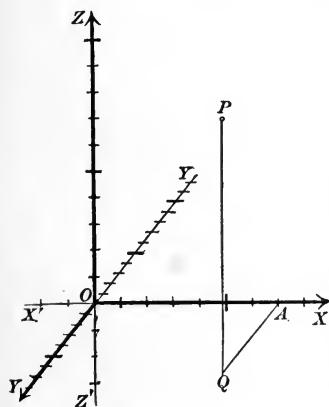

If the coördinate planes are not mutually perpendicular, we still have an analogous system of coördinates called **oblique coördinates**. In this system the coördinates of a point are its distances from the coördinate planes measured parallel to the axes instead of perpendicular to the planes. We shall confine ourselves

to the use of rectangular coördinates.

Points in space may be conveniently plotted by marking the same scale on  $XX'$  and  $ZZ'$  and a somewhat smaller scale on  $YY'$ . Then to plot any point, for example  $(7, 6, 10)$ , we lay off  $OA = 7$  on  $OX$ , draw  $AQ$  parallel to  $OY$  and equal to 6 units on  $OY$ , and  $QP$  parallel to  $OZ$  and equal to 10 units on  $OZ$ .

## PROBLEMS

1. What are the coördinates of the origin?

2. Plot the following sets of points.

(a)  $(8, 0, 2)$ ,  $(-3, 4, 7)$ ,  $(0, 0, 5)$ .

(b)  $(4, -3, 6)$ ,  $(-4, 6, 0)$ ,  $(0, 8, 0)$ .

(c)  $(10, 3, -4)$ ,  $(-4, 0, 0)$ ,  $(0, 8, 4)$ .

(d)  $(3, -4, -8)$ ,  $(-5, -6, 4)$ ,  $(8, 6, 0)$ .

(e)  $(-4, -8, -6)$ ,  $(3, 0, 7)$ ,  $(6, -4, 2)$ .

(f)  $(-6, 4, -4)$ ,  $(0, -4, 6)$ ,  $(9, 7, -2)$ .

3. Where can a point move if  $x = 0$ ? if  $y = 0$ ? if  $z = 0$ ?

4. Where can a point move if  $x = 0$  and  $y = 0$ ? if  $y = 0$  and  $z = 0$ ? if  $z = 0$  and  $x = 0$ ?

5. Show that the points  $(x, y, z)$  and  $(-x, y, z)$  are symmetrical with respect to the  $YZ$ -plane;  $(x, y, z)$  and  $(x, -y, z)$  with respect to the  $ZX$ -plane;  $(x, y, z)$  and  $(x, y, -z)$  with respect to the  $XY$ -plane.

6. Show that the points  $(x, y, z)$  and  $(-x, -y, z)$  are symmetrical with respect to  $ZZ'$ ;  $(x, y, z)$  and  $(x, -y, -z)$  with respect to  $XX'$ ;  $(x, y, z)$  and  $(-x, y, -z)$  with respect to  $YY'$ ;  $(x, y, z)$  and  $(-x, -y, -z)$  with respect to the origin.

7. What is the value of  $z$  if  $P(x, y, z)$  is in the  $XY$ -plane? of  $x$  if  $P$  is in the  $YZ$ -plane? of  $y$  if  $P$  is in the  $ZX$ -plane?

8. What are the values of  $y$  and  $z$  if  $P(x, y, z)$  is on the  $X$ -axis? of  $z$  and  $x$  if  $P$  is on the  $Y$ -axis? of  $x$  and  $y$  if  $P$  is on the  $Z$ -axis?

9. A rectangular parallelepiped lies in the octant  $O-XYZ$  with three faces in the coördinate planes. If its dimensions are  $a$ ,  $b$ , and  $c$ , what are the coördinates of its vertices?

**85. Orthogonal projections. Lengths.** The definitions of the orthogonal projection (p. 22) of a point upon a line and of a directed length  $AB$  upon a directed line hold when the points and lines lie in space instead of in the plane. It is evident that the projection of a point upon a line may also be regarded as the point of intersection of the line and the plane passed through the point perpendicular to the line. As two parallel planes are equidistant, then *the projections of a directed length  $AB$  upon two parallel lines whose positive directions agree are equal.*

From the preceding definitions follows at once as on p. 24,

**Theorem I.** Given any two points  $P_1(x_1, y_1, z_1)$  and  $P_2(x_2, y_2, z_2)$ , then

$$x_2 - x_1 = \text{projection of } P_1P_2 \text{ upon } XX',$$

$$y_2 - y_1 = \text{projection of } P_1P_2 \text{ upon } YY',$$

$$z_2 - z_1 = \text{projection of } P_1P_2 \text{ upon } ZZ'.$$

**Theorem II.** The length  $l$  of the line joining two points  $P_1(x_1, y_1, z_1)$  and  $P_2(x_2, y_2, z_2)$  is given by

$$(II) \quad l = \sqrt{(x_1 - x_2)^2 + (y_1 - y_2)^2 + (z_1 - z_2)^2}.$$

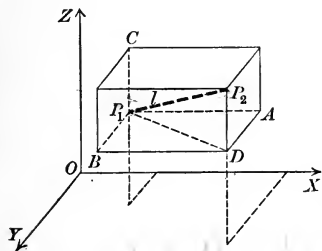

The proof is similar to that for the plane, p. 24.

If we construct a rectangular parallelepiped by passing planes through  $P_1$  and  $P_2$  parallel to the coördinate planes, its edges will be parallel to the axes and equal numerically to the projections of  $P_1P_2$  upon the axes.  $P_1P_2$  will be a diagonal of this parallelepiped, and hence  $l^2$  will equal the sum of the squares of its three dimensions, that is, of the numerical values of  $x_1 - x_2$ ,  $y_1 - y_2$ , and  $z_1 - z_2$ .

### PROBLEMS

1. Find the length of the line joining

(a)  $P_1(4, 3, -2)$  to  $P_2(-2, 1, -5)$ .

Ans. 7.

(b)  $P_1(4, 7, -2)$  to  $P_2(3, 5, -4)$ .

Ans. 3.

(c)  $P_1(3, -8, 6)$  to  $P_2(6, -4, 6)$ .

Ans. 5.

2. Show that the points  $(-3, 2, -7)$ ,  $(2, 2, -3)$ , and  $(-3, 6, -2)$  are the vertices of an isosceles triangle.

3. Show that the points  $(4, 3, -4)$ ,  $(-2, 9, -4)$ , and  $(-2, 3, 2)$  are the vertices of an equilateral triangle.

4. Show that the points  $(-4, 0, 2)$ ,  $(-1, 3\sqrt{3}, 2)$ ,  $(2, 0, 2)$ , and  $(-1, \sqrt{3}, 2 + 2\sqrt{6})$  are the vertices of a regular tetraedron.

5. What does formula (II) become if  $P_1$  and  $P_2$  lie in the  $XY$ -plane? in a plane parallel to the  $XY$ -plane?

6. The coördinates  $(x, y, z)$  of the point of division  $P$  on the line joining  $P_1(x_1, y_1, z_1)$  and  $P_2(x_2, y_2, z_2)$  such that the ratio of the segments is

$$\frac{P_1P}{PP_2} = \lambda$$

are given by the formulas

$$x = \frac{x_1 + \lambda x_2}{1 + \lambda}, \quad y = \frac{y_1 + \lambda y_2}{1 + \lambda}, \quad z = \frac{z_1 + \lambda z_2}{1 + \lambda}.$$

Hint. This is proved as on p. 32.

7. The coördinates  $(x, y, z)$  of the middle point  $P$  of the line joining  $P_1(x_1, y_1, z_1)$  and  $P_2(x_2, y_2, z_2)$  are

$$x = \frac{1}{2}(x_1 + x_2), \quad y = \frac{1}{2}(y_1 + y_2), \quad z = \frac{1}{2}(z_1 + z_2).$$

8. Find the coördinates of the point dividing the line joining the following points in the ratio given.

- |                                |                           |  |
|--------------------------------|---------------------------|--|
| (a) $(3, 4, 2), (7, -6, 4),$   | $\lambda = \frac{1}{2}.$  | <i>Ans.</i> $(\frac{13}{3}, \frac{2}{3}, \frac{8}{3}).$  |
| (b) $(-1, 4, -6), (2, 3, -7),$ | $\lambda = -3.$           | <i>Ans.</i> $(\frac{7}{2}, \frac{5}{2}, -\frac{13}{2}).$ |
| (c) $(8, 4, 2), (3, 9, 6),$    | $\lambda = -\frac{1}{3}.$ | <i>Ans.</i> $(\frac{23}{3}, \frac{3}{2}, 0).$            |
| (d) $(7, 3, 9), (2, 1, 2),$    | $\lambda = 4.$            | <i>Ans.</i> $(3, \frac{7}{5}, \frac{17}{5}).$            |

9. Show that the points  $(7, 3, 4), (1, 0, 6),$  and  $(4, 5, -2)$  are the vertices of a right triangle.

10. Show that each of the following sets of points lies on a straight line, and find the ratio of the segments in which the third divides the line joining the first to the second.

- |  |                            |
|--|----------------------------|
| (a) $(4, 13, 3), (3, 6, 4),$ and $(2, -1, 5).$     | <i>Ans.</i> $-2.$          |
| (b) $(4, -5, -12), (-2, 4, 6),$ and $(2, -2, -6).$ | <i>Ans.</i> $\frac{1}{2}.$ |
| (c) $(-3, 4, 2), (7, -2, 6),$ and $(2, 1, 4).$     | <i>Ans.</i> $1.$           |

11. Find the lengths of the medians of the triangle whose vertices are the points  $(3, 4, -2), (7, 0, 8),$  and  $(-5, 4, 6).$  *Ans.*  $\sqrt{113}, \sqrt{89}, 2\sqrt{29}.$

12. Show that the lines joining the middle points of the opposite sides of the quadrilaterals whose vertices are the following points bisect each other.

- (b)  $(8, 4, 2), (0, 2, 5), (-3, 2, 4),$  and  $(8, 0, -6).$   
 (a)  $(0, 0, 9), (2, 6, 8), (-8, 0, 4),$  and  $(0, -8, 6).$   
 (c)  $P_1(x_1, y_1, z_1), P_2(x_2, y_2, z_2), P_3(x_3, y_3, z_3), P_4(x_4, y_4, z_4).$

13. Find the coördinates of the point of intersection of the medians of the triangle whose vertices are  $(3, 6, -2), (7, -4, 3),$  and  $(-1, 4, -7).$   
*Ans.*  $(3, 2, -2).$

14. Find the coördinates of the point of intersection of the medians of the triangle whose vertices are any three points  $P_1, P_2,$  and  $P_3.$

$$\text{Ans. } [\frac{1}{3}(x_1 + x_2 + x_3), \frac{1}{3}(y_1 + y_2 + y_3), \frac{1}{3}(z_1 + z_2 + z_3)].$$

15. The three lines joining the middle points of the opposite edges of a tetraedron pass through the same point and are bisected at that point.

16. The four lines drawn from the vertices of any tetraedron to the point of intersection of the medians of the opposite face meet in a point which is three fourths of the distance from each vertex to the opposite face (the center of gravity of the tetraedron).

17. The points  $(x_1, y_1, z_1), (x_1 + a, y_1 + a, z_1),$  and  $(x_1, y_1 + a, z_1 + a)$  are the vertices of an equilateral triangle.

## CHAPTER XI

### SURFACES, CURVES, AND EQUATIONS

**86. Loci in space.** In Solid Geometry it is necessary to consider two kinds of loci :

1. The locus of a point in space which satisfies *one* given condition is, in general, a *surface*.

Thus the locus of a point at a given distance from a fixed point is a sphere, and the locus of a point equidistant from two fixed points is the plane which is perpendicular to the line joining the given points at its middle point.

2. The locus of a point in space which satisfies *two* conditions \* is, in general, a *curve*. For the locus of a point which satisfies either condition is a surface, and hence the points which satisfy both conditions lie on two surfaces, that is, on their curve of intersection.

Thus the locus of a point which is at a given distance  $r$  from a fixed point  $P_1$  and is equally distant from two fixed points  $P_2$  and  $P_3$  is the circle in which the sphere whose center is  $P_1$  and whose radius is  $r$  intersects the plane which is perpendicular to  $P_2P_3$  at its middle point.

These two kinds of loci must be carefully distinguished.

**87. Equation of a surface. First fundamental problem.** If any point  $P$  which lies on a given surface be given the coördinates  $(x, y, z)$ , then the condition which defines the surface as a locus will lead to an equation involving the variables  $x, y$ , and  $z$ .

The **equation of a surface** is an equation in the variables  $x, y$ , and  $z$  representing coördinates such that :

1. The coördinates of every point on the surface will satisfy the equation.

2. Every point whose coördinates satisfy the equation will lie upon the surface.

\* The number of conditions must be counted carefully. Thus if a point is to be equidistant from three fixed points  $P_1, P_2$ , and  $P_3$ , it satisfies *two* conditions, namely, of being equidistant from  $P_1$  and  $P_2$  and from  $P_2$  and  $P_3$ .

If the surface is defined as the locus of a point satisfying one condition, its equation may be found in many cases by a Rule analogous to that on p. 46.

**Ex. 1.** Find the equation of the locus of a point whose distance from  $P_1(3, 0, -2)$  is 4.

*Solution.* Let  $P(x, y, z)$  be any point on the locus. The given condition may be written

$$P_1P = 4.$$

By (II), p. 199,  $P_1P = \sqrt{(x-3)^2 + y^2 + (z+2)^2}.$

$$\therefore \sqrt{(x-3)^2 + y^2 + (z+2)^2} = 4.$$

Simplifying, we obtain as the required equation

$$x^2 + y^2 + z^2 - 6x + 4z - 3 = 0.$$

That this is the equation of the locus should be verified as in Ex. 1, p. 45.

We may easily prove

**Theorem I.** *The equation of a plane which is*

*parallel to the XY-plane has the form  $z = \text{constant}$ ;*

*parallel to the YZ-plane has the form  $x = \text{constant}$ ;*

*parallel to the ZX-plane has the form  $y = \text{constant}$ .*

### PROBLEMS

1. Find the equation of the locus of a point which is (a) 3 units above the XY-plane; (b) 4 units to the right of the YZ-plane; (c) 10 units back of the ZX-plane. *3=3, x=4, y=-10 ie a pt.*

2. Find the equation of the plane which is parallel to (a) the XY-plane and 4 units above it; (b) the ZX-plane and 3 units in front of it; (c) the YZ-plane and 7 units to the left of it.

3. Find the equation of the sphere whose center is  $(\alpha, \beta, \gamma)$  and whose radius is  $r$ . *Ans.  $x^2 + y^2 + z^2 - 2\alpha x - 2\beta y - 2\gamma z + \alpha^2 + \beta^2 + \gamma^2 - r^2 = 0.$*

4. What are the equations of the coördinate planes?

5. Find the equation of the locus of a point which is equally distant from the points  $(3, 2, -1)$  and  $(4, -3, 0)$ . *Ans.  $2x - 10y + 2z - 11 = 0.$*

**88. Equations of a curve. First fundamental problem.** If any point  $P$  which lies on a given curve be given the coördinates  $(x, y, z)$ , then the two conditions which define the curve as a locus will lead to two equations involving the variables  $x, y,$  and  $z$ .

The equations of a curve are *two* equations in the variables  $x$ ,  $y$ , and  $z$  representing coördinates such that:

1. The coördinates of every point on the curve will satisfy both equations.

2. Every point whose coördinates satisfy both equations will lie on the curve.

If the curve is defined as the locus of a point satisfying two conditions, the equations of the surfaces defined by each condition separately may be found in many cases by a Rule analogous to that on p. 46. These equations will be the equations of the curve.

**Ex. 1.** Find the equations of the locus of a point whose distance from the origin is 4 and which is equally distant from the points  $P_1(8, 0, 0)$  and  $P_2(0, 8, 0)$ .

*Solution.* First step. Let  $P(x, y, z)$  be any point on the locus.

Second step. The given conditions are

$$(1) \quad PO = 4, \quad PP_1 = PP_2.$$

Third step. By (II), p. 199,

$$PO = \sqrt{x^2 + y^2 + z^2},$$

$$PP_1 = \sqrt{(x-8)^2 + y^2 + z^2},$$

$$PP_2 = \sqrt{x^2 + (y-8)^2 + z^2}.$$

Substituting in (1), we get

$$\sqrt{x^2 + y^2 + z^2} = 4, \quad \sqrt{(x-8)^2 + y^2 + z^2} = \sqrt{x^2 + (y-8)^2 + z^2}.$$

Squaring and reducing, we have the required equations, namely,

$$x^2 + y^2 + z^2 = 16, \quad x - y = 0.$$

These equations should be verified as in Ex. 1, p. 45.

**Ex. 2.** Find the equations of the circle lying in the  $XY$ -plane whose center is the origin and whose radius is 5.

*Solution.* In Plane Geometry the equation of the circle is (Corollary, p. 51)

$$(2) \quad x^2 + y^2 = 25.$$

Regarded as a problem in Solid Geometry we must have *two* equations which the coördinates of any point  $P(x, y, z)$  which lies on the circle must satisfy. Since  $P$  lies in the  $XY$ -plane,

$$(3) \quad z = 0.$$

Hence equations (2) and (3) together express that the point  $P$  lies in the  $XY$ -plane and on the given circle. The equations of the circle are therefore

$$x^2 + y^2 = 25, \quad z = 0.$$

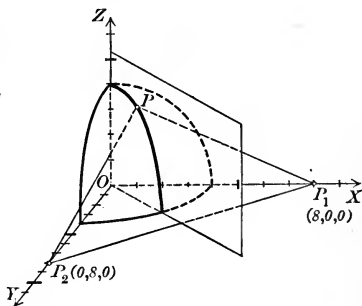

The reasoning in Ex. 2 is general. Hence

*If the equation of a curve in the  $XY$ -plane is known, then the equations of that curve regarded as a curve in space are the given equation and  $z = 0$ .*

An analogous statement evidently applies to the equations of a curve lying in one of the other coordinate planes.

From Theorem I, p. 202, we have at once

**Theorem II.** *The equations of a line which is parallel to*

*the  $X$ -axis have the form  $y = \text{constant}$ ,  $z = \text{constant}$ ;*

*the  $Y$ -axis have the form  $z = \text{constant}$ ,  $x = \text{constant}$ ;*

*the  $Z$ -axis have the form  $x = \text{constant}$ ,  $y = \text{constant}$ .*

### PROBLEMS

1. Find the equations of the locus of a point which is

- (a) 3 units above the  $XY$ -plane and 4 units to the right of the  $YZ$ -plane.
- (b) 5 units to the left of the  $YZ$ -plane and 2 units in front of the  $ZX$ -plane.
- (c) 4 units back of the  $ZX$ -plane and 7 units to the left of the  $YZ$ -plane.
- (d) 9 units below the  $XY$ -plane and 4 units to the right of the  $YZ$ -plane.

2. Find the equations of the straight line which is

- (a) 5 units above the  $XY$ -plane and 2 units in front of the  $ZX$ -plane.
- (b) 2 units to the left of the  $YZ$ -plane and 8 units below the  $XY$ -plane.
- (c) 3 units to the right of the  $YZ$ -plane and 5 units from the  $Z$ -axis.
- (d) 13 units from the  $X$ -axis and 5 units back of the  $ZX$ -plane.
- (e) parallel to the  $Y$ -axis and passing through  $(3, 7, -5)$ .
- (f) parallel to the  $Z$ -axis and passing through  $(-4, 7, 6)$ .

3. Find the equations of the locus of a point which is

- (a) 5 units above the  $XY$ -plane and 3 units from  $(3, 7, 1)$ .

$$\text{Ans. } z = 5, x^2 + y^2 + z^2 - 6x - 14y - 2z + 50 = 0.$$

- (b) 2 units from  $(3, 7, 6)$  and 4 units from  $(2, 5, 4)$ .

$$\text{Ans. } x^2 + y^2 + z^2 - 6x - 14y - 12z + 90 = 0,$$

$$x^2 + y^2 + z^2 - 4x - 10y - 8z + 29 = 0.$$

- (c) 5 units from the origin and equidistant from  $(3, 7, 2)$  and  $(-3, -7, -2)$ .

$$\text{Ans. } x^2 + y^2 + z^2 - 25 = 0, 3x + 7y + 2z = 0.$$

- (d) equidistant from  $(3, 5, -4)$  and  $(-7, 1, 6)$ , and also from  $(4, -6, 3)$  and  $(-2, 8, 5)$ .

$$\text{Ans. } 5x + 2y - 5z + 11 = 0, 3x - 7y - z + 8 = 0.$$

- (e) equidistant from  $(2, 3, 7)$ ,  $(3, -4, 6)$ , and  $(4, 3, -2)$ .

$$\text{Ans. } 2x - 14y - 2z + 1 = 0, x + y - 8z + 16 = 0.$$



4. What are the equations of the edges of a rectangular parallelepiped whose dimensions are  $a$ ,  $b$ , and  $c$ , if three of its faces coincide with the coordinate planes and one vertex lies in  $O$ - $XYZ$ ? in  $O$ - $XY'Z$ ? in  $O$ - $X'Y'Z$ ?

5. What are the equations of the axes of coordinates?

6. The following equations are the equations of curves lying in one of the coordinate planes. What are the equations of the same curves regarded as curves in space?

(a)  $y^2 = 4x$ .

(e)  $x^2 + 4z + 6x = 0$ .

(b)  $x^2 + z^2 = 16$ .

(f)  $y^2 - z^2 - 4y = 0$ .

(c)  $8x^2 - y^2 = 64$ .

(g)  $yz^2 + z^2 - 6y = 0$ .

(d)  $4z^2 + 9y^2 = 36$ .

(h)  $z^2 - 4x^2 + 8z = 0$ .

7. Find the equations of the locus of a point which is equally distant from the points  $(6, 4, 3)$  and  $(6, 4, 9)$ , and also from  $(-5, 8, 3)$  and  $(-5, 0, 3)$ , and determine the nature of the locus. Ans.  $z = 6, y = 4$ .

8. Find the equations of the locus of a point which is equally distant from the points  $(3, 7, -4)$ ,  $(-5, 7, -4)$ , and  $(-5, 1, -4)$ , and determine the nature of the locus. Ans.  $x = -1, y = 4$ .

**89. Locus of one equation. Second fundamental problem.**  
The locus of one equation in three variables (one or two may be lacking) representing coordinates in space is the *surface* passing through all points whose coordinates satisfy that equation and through such points only.

The coordinates of points on the surface may be obtained as follows:

Solve the equation for one of the variables, say  $z$ , assume pairs of values of  $x$  and  $y$ , and compute the corresponding values of  $z$ .

A rough model of the surface might then be constructed by taking a thin board for the  $XY$ -plane, sticking needles into it at the assumed points  $(x, y)$  whose lengths are the computed values of  $z$ , and stretching a sheet of rubber over their extremities.

The second fundamental problem, namely, of constructing the locus, is usually discarded in space on account of the mechanical difficulties involved.

**90. Locus of two equations. Second fundamental problem.**  
The locus of two equations in three variables representing coordinates in space is the *curve* passing through all points whose coordinates satisfy both equations and through such points only.

The coordinates of points on the curve may be obtained as follows:

Solve the equations for two of the variables, say  $x$  and  $y$ , in terms of the third,  $z$ , assume values for  $z$ , and compute the corresponding values of  $x$  and  $y$ .

**91. Discussion of the equations of a curve. Third fundamental problem.** The discussion of curves in Elementary Analytic Geometry is largely confined to curves which lie entirely in a plane which is usually parallel to one of the coördinate planes. Such a curve is defined as the intersection of a given surface with a plane parallel to one of the coördinate planes. The method of determining its nature is illustrated in

**Ex. 1.** Determine the nature of the curve in which the plane  $z = 4$  intersects the surface whose equation is  $y^2 + z^2 = 4x$ .

*Solution.* The equations of the curve are, by definition,

$$(1) \quad y^2 + z^2 = 4x, \quad z = 4.$$

Eliminate  $z$  by substituting from the second equation in the first. This gives

$$(2) \quad y^2 - 4x + 16 = 0, \quad z = 4.$$

Equations (2) are also the equations of the curve.

For every set of values of  $(x, y, z)$  which satisfy both of equations (1) will evidently satisfy both of equations (2), and conversely.

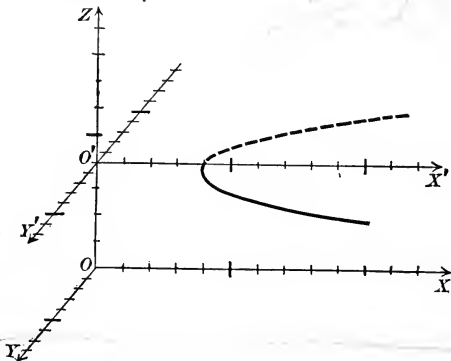

If we take as axes in the plane  $z = 4$  the lines  $O'X'$  and  $O'Y'$  in which the plane cuts the  $ZX$ - and  $YZ$ -planes, then the equation of the curve when referred to these axes is the first of equations (2), namely,

$$(3) \quad y^2 - 4x + 16 = 0.$$

For the second of equations (2) is satisfied by all points in the plane of  $X', O'$ , and  $Y'$ , and the first of equations (2) is satisfied by the points in that plane lying on the curve (3), because the values of the first two coördinates of a point are evidently the same when referred to the axes  $O'X', O'Y'$ , and  $O'Z$  as when referred to the axes  $OX, OY$ , and  $OZ$ .

The locus of (3) is a parabola (Rule, p. 173) whose vertex, in the plane  $z = 4$ , is the point  $(4, 0)$  for which  $p = 2$ .

The method employed in Ex. 1 enables us to state the

**Rule** to determine the nature of the curve in which a plane parallel to one of the coördinate planes cuts a given surface.

*First step.* Eliminate the variable occurring in the equation of the plane from the equations of the plane and surface. The result is the equation of the curve referred to the lines in which the given plane cuts the other two coördinate planes as axes.

*Second step.* Determine the nature of the curve obtained in the second step by the methods of Plane Analytic Geometry.

### PROBLEMS

1. Determine the nature of the following curves and construct their loci.

(a)  $x^2 - 4y^2 = 8z, z = 8.$

(e)  $x^2 + 4y^2 + 9z^2 = 36, y = 1.$

(b)  $x^2 + 9y^2 = 9z^2, z = 2.$

(f)  $x^2 - 4y^2 + z^2 = 25, x = -3.$

(c)  $x^2 - 4y^2 = 4z, y = -2.$

(g)  $x^2 - y^2 - 4z^2 + 6x = 0, x = 2.$

(d)  $x^2 + y^2 + z^2 = 25, x = 3.$

(h)  $y^2 + z^2 - 4x + 8 = 0, y = 4.$

2. Construct the curves in which each of the following surfaces intersect the coördinate planes.

(a)  $x^2 + 4y^2 + 16z^2 = 64.$

(d)  $x^2 + 9y^2 = 10z.$

(b)  $x^2 + 4y^2 - 16z^2 = 64.$

(e)  $x^2 - 9y^2 = 10z.$

(c)  $x^2 - 4y^2 - 16z^2 = 64.$

(f)  $x^2 + 4y^2 - 16z^2 = 0.$

3. Determine the nature of the intersection of the surface  $2x + y = 2z$  with the plane  $y = k$ ; with the plane  $z = k'$ . How does the intersection change as  $k$  or  $k'$  changes? What idea of the form of the surface is obtained?

4. Determine the nature of the intersection of the surface  $x^2 + y^2 + 4z^2 = 64$  with the plane  $z = k$ . How does the curve change as  $k$  increases from 0 to 4? from  $-4$  to 0? What idea of the appearance of the surface is thus obtained?

5. Determine the nature of the intersection of the surface  $4x - 2y = 4$  with the plane  $y = k$ ; with the plane  $z = k'$ . How does the intersection change as  $k$  or  $k'$  changes? What idea of the form of the surface is obtained?

**92. Discussion of the equation of a surface. Third fundamental problem.**

**Theorem III.** *The locus of an algebraic equation passes through the origin if there is no constant term in the equation.*

The proof is analogous to that of Theorem VI, p. 66.

**Theorem IV.** *If the locus of an equation is unaffected by changing the sign of one variable throughout its equation, then the locus is symmetrical with respect to the coördinate plane from which that variable is measured.* *Handwritten:  $y \rightarrow -y$ ,  $z$  symmetrical to  $z=0$  - plane*

*If the locus is unaffected by changing the signs of two variables throughout its equation, it is symmetrical with respect to the axis along which the third variable is measured.*

*If the locus is unaffected by changing the signs of all three variables throughout its equation, it is symmetrical with respect to the origin.*

The proof is analogous to that of Theorem IV, p. 65.

**Rule to find the intercepts of a surface on the axes of coördinates.**

*Set each pair of variables equal to zero and solve for real values of the third.*

The curves in which a surface intersects the coördinate planes are called its traces on the coördinate planes. From the first step of the Rule, p. 207, it is seen that

*The equations of the traces of a surface are obtained by successively setting  $x = 0$ ,  $y = 0$ , and  $z = 0$  in the equation of the surface.*

By these means we can determine some properties of the surface. The general appearance of a surface is determined by considering the curves in which it is cut by a system of planes parallel to each of the coördinate planes (Rule, p. 207). This also enables us to

*determine whether the surface is closed or recedes to infinity.*

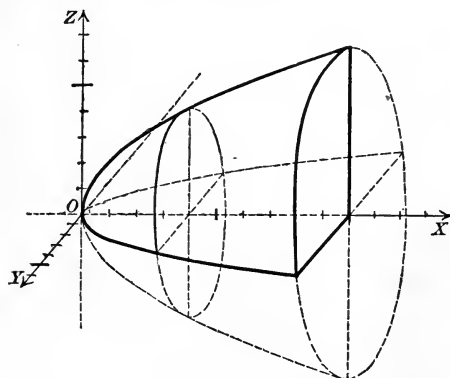

**Ex. 1.** Discuss the locus of the equation  $y^2 + z^2 = 4x$ .

**Solution.** 1. The surface passes through the origin since there is no constant term in its equation.

2. The surface is symmetrical with respect to the  $XY$ -plane, the  $ZX$ -plane, and the  $X$ -axis.

For the locus of the given equation is unaffected by changing the sign of  $z$ , of  $y$ , or of both together.

3. It cuts the axes at the origin only.  $x=0$

4. Its traces are respectively the point-circle  $y^2 + z^2 = 0$  and the parabolas  $z^2 = 4x$  and  $y^2 = 4x$ .

5. It intersects the plane  $x = k$  in the curve (Rule, p. 207)

$$y^2 + z^2 = 4k.$$

This curve is a circle whose center is the origin, that is, is on the  $X$ -axis, and whose radius is  $2\sqrt{k}$  if  $k > 0$ , but there is no locus if  $k < 0$ . Hence the surface lies entirely to the right of the  $YZ$ -plane.

If  $k$  increases from zero to infinity, the radius of the circle increases from zero to infinity while the plane  $x = k$  recedes from the  $YZ$ -plane.

The intersection of a plane  $z = k$  or  $y = k'$ , parallel to the  $XY$ - or  $ZX$ -plane, is seen (Rule, p. 207) to be a parabola whose equation is (compare Ex. 1, p. 206)

$$y^2 = 4x - k^2 \quad \text{or} \quad z^2 = 4x - k'^2.$$

These parabolas are found to have the same value of  $p$ , namely,  $p = 2$ , and their vertices recede from the  $YZ$ - or  $ZX$ -plane as  $k$  or  $k'$  increases numerically.

### PROBLEMS

1. Discuss the loci of the following equations.

(a)  $x^2 + z^2 = 4x$ .

(f)  $x^2 + y^2 - z^2 = 0$ .

(b)  $x^2 + y^2 + 4z^2 = 16$ .

(g)  $x^2 - y^2 - z^2 = 9$ .

(c)  $x^2 + y^2 - 4z^2 = 16$ .

(h)  $x^2 + y^2 - z^2 + 2xy = 0$ .

(d)  $6x + 4y + 3z = 12$ .

(i)  $x + y - 6z = 6$ .

(e)  $3x + 2y + z = 12$ .

(j)  $y^2 + z^2 = 25$ .

2. Show that the locus of  $Ax + By + Cz + D = 0$  is a plane by considering its traces on the coordinate planes and the sections made by a system of planes parallel to one of the coordinate planes.

3. Find the equation of the locus of a point which is equally distant from the point  $(2, 0, 0)$  and the  $YZ$ -plane and discuss the locus.

$$\text{Ans. } y^2 + z^2 - 4x + 4 = 0.$$

4. Find the equation of the locus of a point whose distance from the point  $(0, 0, 3)$  is twice its distance from the  $XY$ -plane and discuss the locus.

$$\text{Ans. } x^2 + y^2 - 3z^2 - 6z + 9 = 0.$$

5. Find the equation of the locus of a point whose distance from the point  $(0, 4, 0)$  is three fifths its distance from the  $ZX$ -plane and discuss the locus.

$$\text{Ans. } 25x^2 + 16y^2 + 25z^2 - 200y + 400 = 0.$$

Consider now in turn loci defined by equations of the first and second degree in  $x$ ,  $y$ , and  $z$ .

### EQUATIONS OF THE FIRST DEGREE

**93. Plane and straight line.** We confine ourselves to the two theorems.

**Theorem V. Plane.** *The locus of the general equation of the first degree in  $x$ ,  $y$ , and  $z$ ,*

$$(V) \quad Ax + By + Cz + D = 0,$$

*is a plane.*

The proof follows the method explained in problem 2, p. 209.

**Theorem VI. Straight line.** *The locus of two equations of the first degree,*

$$(VI) \quad \begin{cases} A_1x + B_1y + C_1z + D_1 = 0, \\ A_2x + B_2y + C_2z + D_2 = 0, \end{cases}$$

*is a straight line unless the coefficients of  $x$ ,  $y$ , and  $z$  are proportional.*

The proof follows at once from Theorem V and Elementary Geometry. If the coefficients are proportional, it is readily seen that the traces (p. 208) of the planes are parallel (p. 78), and hence the planes are parallel.

To plot a straight line we need to know only the coördinates of two points on the line. The easiest points to obtain are usually those lying in the coördinate planes, which we get by setting one of the variables equal to zero and solving for the other two. If a line cuts but one of the coördinate planes, we get only one point in this way, and to plot the line we draw a line through that point parallel to the axis which is perpendicular to that plane.

### PROBLEMS

1. Find the intercepts on the axes and the traces on the coördinate planes of each of the following planes and construct the figures.

(a)  $2x + 3y + 4z - 24 = 0.$

(e)  $5x - 7y - 3z = 0.$

(b)  $7x - 3y + z - 21 = 0.$

(f)  $4x + 3z + 36 = 0.$

(c)  $8x - 7y - 9z + 63 = 0.$

(g)  $5y - 8z - 40 = 0.$

(d)  $6x + 4y - z + 12 = 0.$

(h)  $3x + 5z + 45 = 0.$

2. Find the points in which the following lines pierce the coördinate planes and construct the lines.

(a)  $2x + y - z = 2, \quad x - y + 2z = 4.$

(c)  $x + 2y = 8, \quad 2x - 4y = 7.$

(b)  $4x + 3y - 6z = 12, \quad 4x - 3y = 2.$

(d)  $y + z = 4, \quad x - y + 2z = 10.$

PLATE I

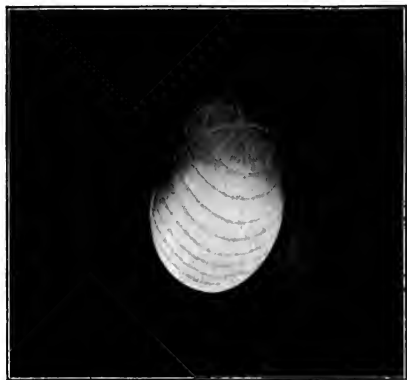

Ellipsoid

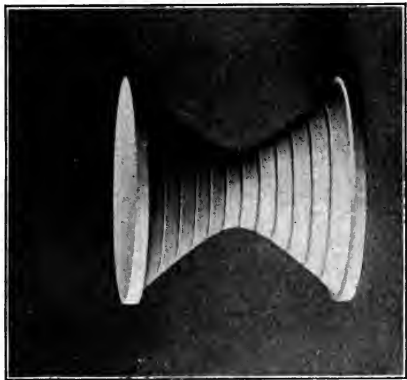

Hyperboloid of one sheet

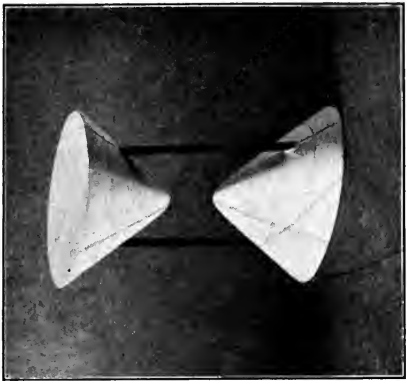

Hyperboloid of two sheets

CENTRAL QUADRICS





3. Find the equation of the plane which passes through the points  $(1, 1, -1)$ ,  $(-2, -2, 2)$ , and  $(1, -1, 2)$ . *Ans.*  $x - 3y - 2z = 0$ .

4. Find the equation of the plane whose intercepts are  $a, b, c$ .

$$\text{Ans. } \frac{x}{a} + \frac{y}{b} + \frac{z}{c} = 1.$$

5. The system of planes passing through the line

$$A_1x + B_1y + C_1z + D_1 = 0, \quad A_2x + B_2y + C_2z + D_2 = 0$$

is represented by

$$A_1x + B_1y + C_1z + D_1 + k(A_2x + B_2y + C_2z + D_2) = 0,$$

where  $k$  is an arbitrary constant.

6. Find the equation of the plane determined by the line  $2x + y - 4 = 0$ ,  $y + 2z = 0$ , and the point  $(2, -1, 1)$ . *Ans.*  $x + y + z - 2 = 0$ .

### EQUATIONS OF THE SECOND DEGREE

The locus of an equation of the second degree, of which the most general form is

$$(1) \quad Ax^2 + By^2 + Cz^2 + Dyz + Ezx + Fxy + Gx + Hy + Iz + K = 0,$$

is called a quadric surface or conicoid. By methods similar to those employed in Chapter VIII, p. 172, it may be shown that the locus of (1) is a pair of planes, one plane, a straight line,\* or one of the loci about to be discussed.

#### 94. The sphere.†

**Theorem VII.** *The equation of the sphere whose center is the point  $(\alpha, \beta, \gamma)$  and whose radius is  $r$  is*

$$(x - \alpha)^2 + (y - \beta)^2 + (z - \gamma)^2 = r^2, \text{ or}$$

$$(VII) \quad x^2 + y^2 + z^2 - 2\alpha x - 2\beta y - 2\gamma z + \alpha^2 + \beta^2 + \gamma^2 - r^2 = 0.$$

*Proof.* Let  $P(x, y, z)$  be any point on the sphere, and denote the center of the sphere by  $C$ . Then, by definition,  $PC = r$ . Substituting the value of  $PC$  given by (II), p. 199, and squaring, we obtain (VII). Q. E. D.

\* For example, the locus of  $x^2 + y^2 = 0$  is the  $Z$ -axis. It is to be regarded as a special case of a cylinder (Theorem IX, p. 213).

† In Analytic Geometry the terms sphere, cylinder, and cone are usually used to denote the spherical surface, cylindrical surface, and conical surface of Elementary Geometry, and not the solids bounded wholly or in part by such surfaces.

**Theorem VIII.** *The locus of an equation of the form*

$$(VIII) \quad x^2 + y^2 + z^2 + Gx + Hy + Iz + K = 0$$

*is determined as follows:*

(a) *When  $G^2 + H^2 + I^2 - 4K > 0$ , the locus is a sphere whose center is  $(-\frac{1}{2}G, -\frac{1}{2}H, -\frac{1}{2}I)$  and whose radius is*

$$r = \frac{1}{2}\sqrt{G^2 + H^2 + I^2 - 4K}.$$

(b) *When  $G^2 + H^2 + I^2 - 4K = 0$ , the locus is the point-sphere\*  $(-\frac{1}{2}G, -\frac{1}{2}H, -\frac{1}{2}I)$ .*

(c) *When  $G^2 + H^2 + I^2 - 4K < 0$ , there is no locus.*

The method of proof is similar to that on p. 115.

### PROBLEMS

1. Find the equation of the sphere whose center is the point

(a)  $(\alpha, 0, 0)$  and whose radius is  $\alpha$ . *Ans.*  $x^2 + y^2 + z^2 - 2\alpha x = 0$ .

(b)  $(0, \beta, 0)$  and whose radius is  $\beta$ . *Ans.*  $x^2 + y^2 + z^2 - 2\beta y = 0$ .

(c)  $(0, 0, \gamma)$  and whose radius is  $\gamma$ . *Ans.*  $x^2 + y^2 + z^2 - 2\gamma z = 0$ .

2. Determine the nature of the loci of the following equations and find the center and radius if the locus is a sphere, or the coördinates of the point-sphere if the locus is a point-sphere.

(a)  $x^2 + y^2 + z^2 - 6x + 4z = 0$ . (c)  $x^2 + y^2 + z^2 + 4x - z + 7 = 0$ .

(b)  $x^2 + y^2 + z^2 + 2x - 4y - 5 = 0$ . (d)  $x^2 + y^2 + z^2 - 12x + 6y + 4z = 0$ .

3. Find the equation of the sphere which

(a) has the center  $(3, 0, -2)$  and passes through  $(1, 6, -5)$ .

$$\text{Ans. } x^2 + y^2 + z^2 - 6x + 4z - 36 = 0.$$

(b) passes through the points  $(0, 0, 0)$ ,  $(0, 2, 0)$ ,  $(4, 0, 0)$ , and  $(0, 0, -6)$ .

$$\text{Ans. } x^2 + y^2 + z^2 - 4x - 2y + 6z = 0.$$

(c) has the line joining  $(4, -6, 5)$  and  $(2, 0, 2)$  as a diameter.

$$\text{Ans. } x^2 + y^2 + z^2 - 6x + 6y - 7z + 18 = 0.$$

4. Given two spheres  $S_1: x^2 + y^2 + z^2 + G_1x + H_1y + I_1z + K_1 = 0$  and  $S_2: x^2 + y^2 + z^2 + G_2x + H_2y + I_2z + K_2 = 0$ ; show that the locus of

$$S_k: x^2 + y^2 + z^2 + G_1x + H_1y + I_1z + K_1 + k(x^2 + y^2 + z^2 + G_2x + H_2y + I_2z + K_2) = 0$$

is a sphere except when  $k = -1$ . In this case the locus is a plane.

5. The center of the sphere  $S_k$  in problem 4 lies on the line of centers of  $S_1$  and  $S_2$  and divides it into segments whose ratio is equal to  $k$ .

\* That is, a point or sphere of radius zero.

6. When two spheres  $S_1$  and  $S_2$  (problem 4) intersect, the system  $S_k$  consists of all spheres passing through their circle of intersection.

7. When the spheres  $S_1$  and  $S_2$  (problem 4) are tangent, the system  $S_k$  consists of all spheres tangent to  $S_1$  and  $S_2$  at their point of tangency.

## 95. Cylinders.

**Ex. 1.** Determine the nature of the locus of  $y^2 = 4x$ .

*Solution.* The intersection of the surface with a plane parallel to the  $YZ$ -plane,  $x = k$ , are the lines (Rule, p. 207)

$$(1) \quad x = k, \quad y = \pm 2\sqrt{k},$$

which are parallel to the  $Z$ -axis (Theorem II, p. 204). If  $k > 0$ , the locus of equations (1) is a pair of lines; if  $k = 0$ , it is a single line (the  $Z$ -axis); and if  $k < 0$ , equations (1) have no locus.

② Similarly, the intersection with a plane parallel to the  $ZX$ -plane,  $y = k$ , is a straight line whose equations are (Rule, p. 207)

$$x = \frac{1}{4}k^2, \quad y = k,$$

and which is therefore parallel to the  $Z$ -axis.

③ The intersection with a plane parallel to the  $XY$ -plane is the parabola

$$z = k, \quad y^2 = 4x.$$

For different values of  $k$  these parabolas are equal and placed one above another.

It is therefore evident that the surface is a cylinder whose elements are parallel to the  $Z$ -axis and intersect the parabola in the  $XY$ -plane

$$y^2 = 4x, \quad z = 0.$$

It is evident from Ex. 1 that the locus of any equation which contains but two of the variables  $x$ ,  $y$ , and  $z$  will intersect planes parallel to two of the coordinate planes in one or more straight lines parallel to one of the axes and planes parallel to the third coordinate plane in equal curves. Such a surface is evidently a cylinder. Hence

**Theorem IX.** *The locus of an equation in which one variable is lacking is a cylinder whose elements are parallel to the axis along which that variable is measured.*

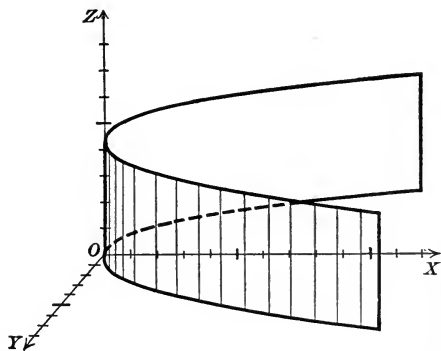

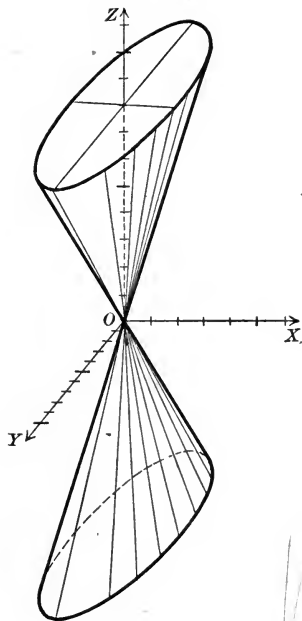

## 96. Cones.

**Ex. 1.** Determine the nature of the locus of the equation  $16x^2 + y^2 - z^2 = 0$ .

*Solution.* Let  $P_1(x_1, y_1, z_1)$  be a point on a curve  $C$  in which the locus intersects plane, for example,  $z = k$ . Then

$$(1) \quad 16x_1^2 + y_1^2 - z_1^2 = 0, \quad z_1 = k.$$

The origin  $O$  lies on the surface (Theorem III, p. 207). It may be shown\* that the line  $OP_1$  lies entirely on the surface, and therefore that the surface is a cone whose vertex is the origin.

In the same way the locus may be shown to be a cone whenever the equation of the surface is *homogeneous* † in the variables  $x$ ,  $y$ , and  $z$ . Hence

**Theorem X.** *The locus of an equation, which is homogeneous in the variables  $x$ ,  $y$ , and  $z$  is a cone whose vertex is the origin.*

## PROBLEMS

1. Determine the nature of the following loci; discuss and construct them.

(a)  $x^2 + y^2 = 36$ .

(e)  $x^2 - y^2 + 36z^2 = 0$ .

(b)  $x^2 + y^2 = z^2$ .

(f)  $y^2 - 16x^2 + 4z^2 = 0$ .

(c)  $y^2 + 4z^2 = 0$ .

(g)  $x^2 + 16y^2 - 4x = 0$ .

(d)  $x^2 - z^2 = 16$ .

(h)  $x^2 + yz = 0$ .

2. Find the equations of the cylinders whose directrices are the following curves and whose elements are parallel to one of the axes.

(a)  $y^2 + z^2 - 4y = 0, x = 0$ .

(c)  $b^2x^2 - a^2y^2 = a^2b^2, z = 0$ .

(b)  $z^2 + 2x = 8, y = 0$ .

(d)  $y^2 + 2pz = 0, x = 0$ .

3. Discuss the following loci.

(a)  $x^2 + y^2 = z^2 \tan^2 \gamma$ .

(c)  $z^2 + x^2 = y^2 \tan^2 \beta$ .

(e)  $y^2 + z^2 = r^2$ .

(b)  $y^2 + z^2 = x^2 \tan^2 \alpha$ .

(d)  $x^2 + y^2 = r^2$ .

(f)  $z^2 + x^2 = r^2$ .

\* *The Elements of Analytic Geometry*, Smith and Gale, p. 385.

† An equation is homogeneous in  $x$ ,  $y$ , and  $z$  when all the terms in the equation are of the same degree (footnote, p. 10).

**97. Non-degenerate quadrics.** If the locus of an equation of the second degree is a cone, cylinder, or pair of planes, it is called a **degenerate quadric**, while the surfaces now to be considered are distinguished as **non-degenerate quadrics**.

The locus of the equation

$$(1) \quad \frac{x^2}{a^2} + \frac{y^2}{b^2} + \frac{z^2}{c^2} = 1,$$

which contains only the squares of the variables with *positive coefficients*, is called an **ellipsoid**. The sections of the surface formed by planes parallel to any one of the coordinate planes (Rule, p. 207) are conics of the elliptic type. If  $a = b = c$ , the locus of (1) is a sphere.

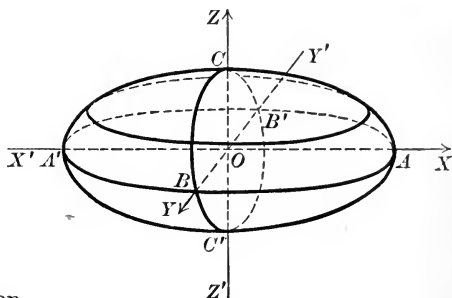

The locus of the equation

$$(2) \quad \frac{x^2}{a^2} + \frac{y^2}{b^2} - \frac{z^2}{c^2} = 1,$$

which contains only the squares of the variables with one negative coefficient, is called an **hyperboloid of one sheet**. The sections of the surface formed by planes parallel to the  $XY$ -plane (Rule, p. 207) are ellipses, while those formed by planes parallel to either of the other coordinate planes are conics of the hyperbolic type. Two systems of straight lines lie on the hyperboloid and it is therefore called a ruled surface.

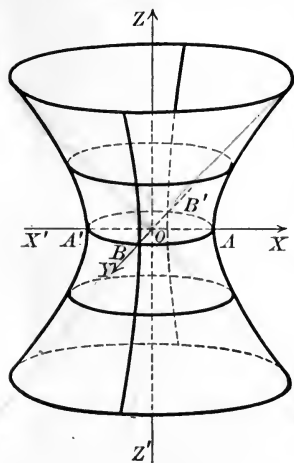

The loci of the equations

$$(3) \quad \frac{x^2}{a^2} - \frac{y^2}{b^2} + \frac{z^2}{c^2} = 1, \quad -\frac{x^2}{a^2} + \frac{y^2}{b^2} + \frac{z^2}{c^2} = 1,$$

are also hyperboloids of one sheet.

The locus of the equation

$$(4) \quad \frac{x^2}{a^2} - \frac{y^2}{b^2} - \frac{z^2}{c^2} = 1,$$

with *two negative coefficients*, is called an **hyperboloid of two sheets**.\*

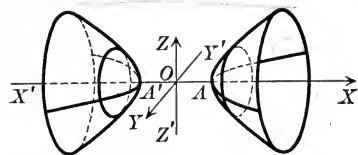

Sections formed by planes parallel to the  $YZ$ -plane (Rule, p. 207) are conics of the elliptic type, while those formed by planes parallel to either of the other

coördinate planes are hyperbolas.

The loci of the equations

$$(5) \quad -\frac{x^2}{a^2} + \frac{y^2}{b^2} - \frac{z^2}{c^2} = 1, \quad -\frac{x^2}{a^2} - \frac{y^2}{b^2} + \frac{z^2}{c^2} = 1,$$

are also hyperboloids of two sheets.

The locus of the equation

$$(6) \quad \frac{x^2}{a^2} + \frac{y^2}{b^2} = 2cz,$$

which contains the squares of two variables with *positive coefficients* and the first power of the third variable, is called an **elliptic paraboloid**.

Sections formed by planes parallel to the  $XY$ -plane (Rule, p. 207) are conics of the elliptic type, while those formed by planes parallel to either of the other coördinate planes are equal parabolas.

The loci of the equations

$$(7) \quad \begin{cases} \frac{y^2}{b^2} + \frac{z^2}{c^2} = 2ax, \\ \frac{x^2}{a^2} + \frac{z^2}{c^2} = 2by, \end{cases}$$

are also elliptic paraboloids.

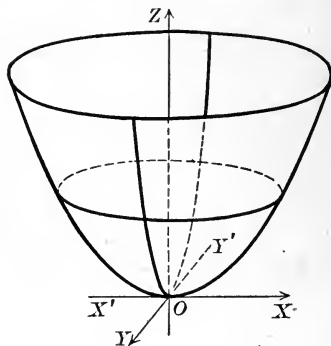

\* The number of sheets refers to the number of separate parts of which the surface consists.

PLATE II



Elliptic Paraboloid

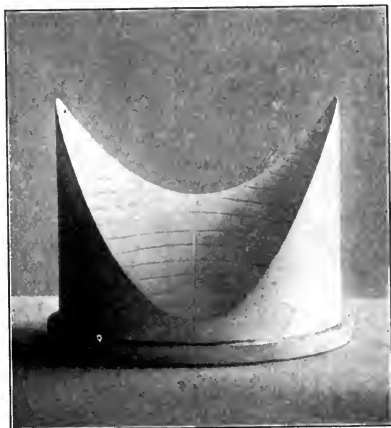

Hyperbolic Paraboloid

NON-CENTRAL QUADRICS



Hyperboloid of one sheet

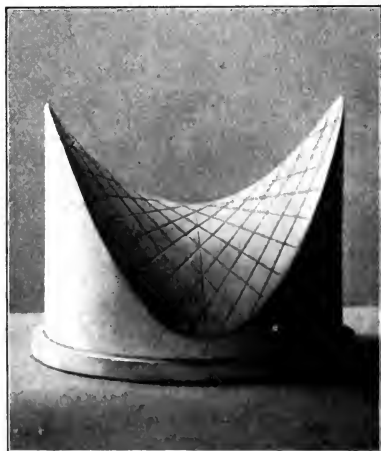

Hyperbolic Paraboloid

RULED QUADRICS

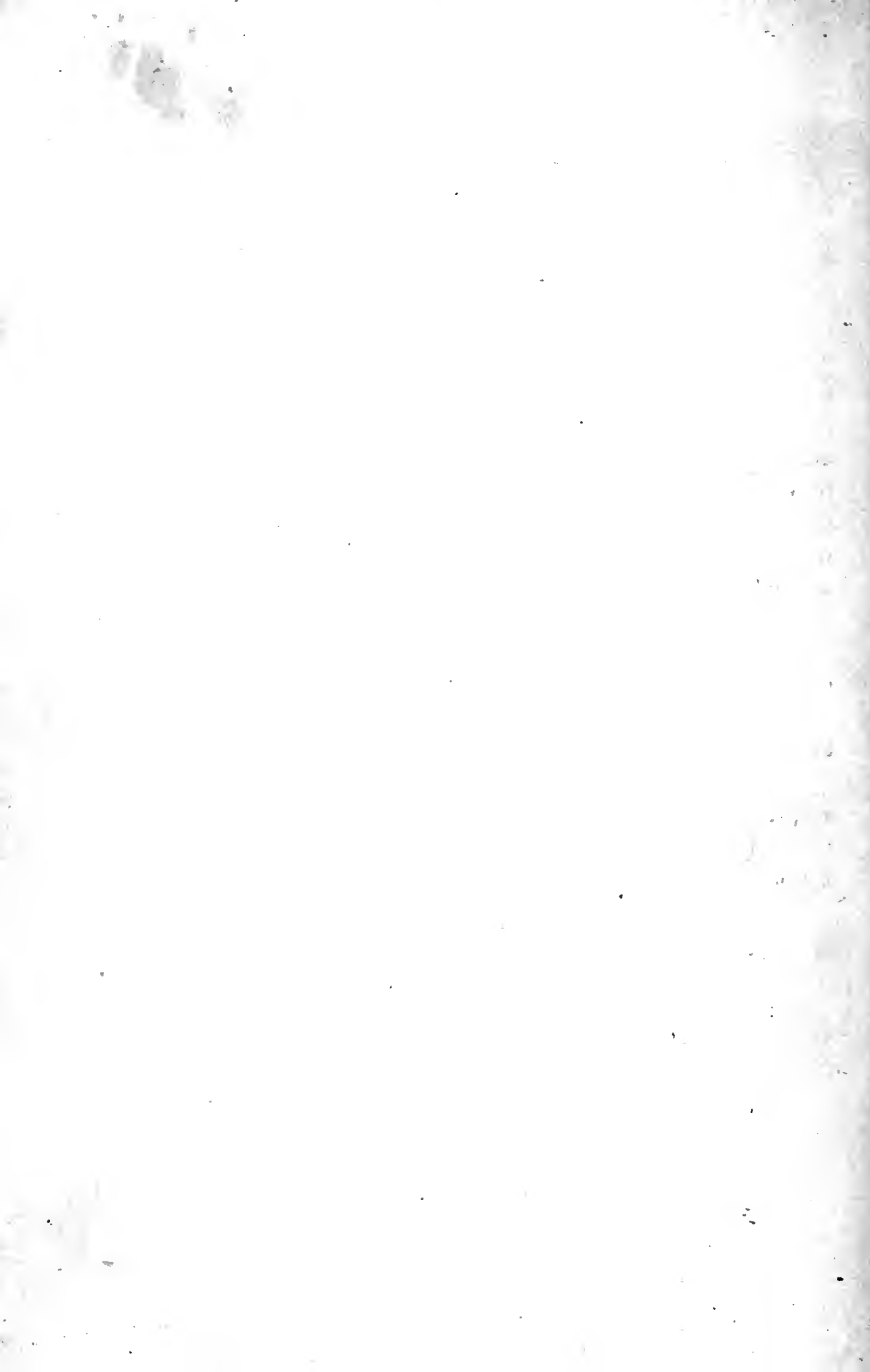



The locus of the equation

$$(8) \quad \frac{x^2}{a^2} - \frac{y^2}{b^2} = 2cz,$$

which differs from (6) in that one of the squares has a *negative coefficient*, is called an **hyperbolic paraboloid**. Sections formed by planes parallel to the  $XY$ -plane (Rule, p. 207) are conics of the hyperbolic type, while those formed by planes parallel to either of the other coordinate planes are equal parabolas. There are two systems of straight lines lying on the surface.

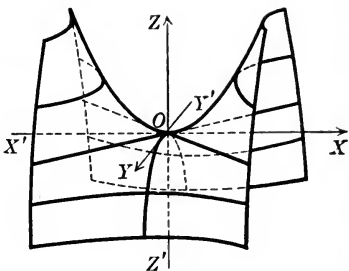

The loci of the equations

$$(9) \quad \frac{x^2}{a^2} - \frac{z^2}{c^2} = 2by, \quad \frac{y^2}{b^2} - \frac{z^2}{c^2} = 2ax,$$

are also hyperbolic paraboloids.

The ellipsoid and the hyperboloids are symmetrical with respect to the origin (Theorem IV, p. 208) and are therefore called **central quadrics**, while the paraboloids are called **non-central quadrics** because they have no center of symmetry.

### PROBLEMS

1. Discuss and construct the loci of the following equations.

(a)  $4x^2 + 9y^2 + 16z^2 = 144.$

(g)  $9x^2 - y^2 + 9z^2 = 36.$

(b)  $4x^2 + 9y^2 - 16z^2 = 144.$

(h)  $z^2 - 4x^2 - 4y^2 = 16.$

(c)  $4x^2 - 9y^2 - 16z^2 = 144.$

(i)  $16x^2 + y^2 + 16z^2 = 64.$

(d)  $x^2 + 16y^2 + z^2 = 64.$

(j)  $x^2 + y^2 - z^2 = 25.$

(e)  $y^2 + z^2 = 4x.$

(k)  $9z^2 - 4x^2 = 288y.$

(f)  $y^2 - z^2 = 4x.$

(l)  $16x^2 + z^2 = 64y.$

2. Show how to generate each of the central quadrics by moving an ellipse whose axes are variable.

3. Show how to generate each of the paraboloids by moving a parabola.



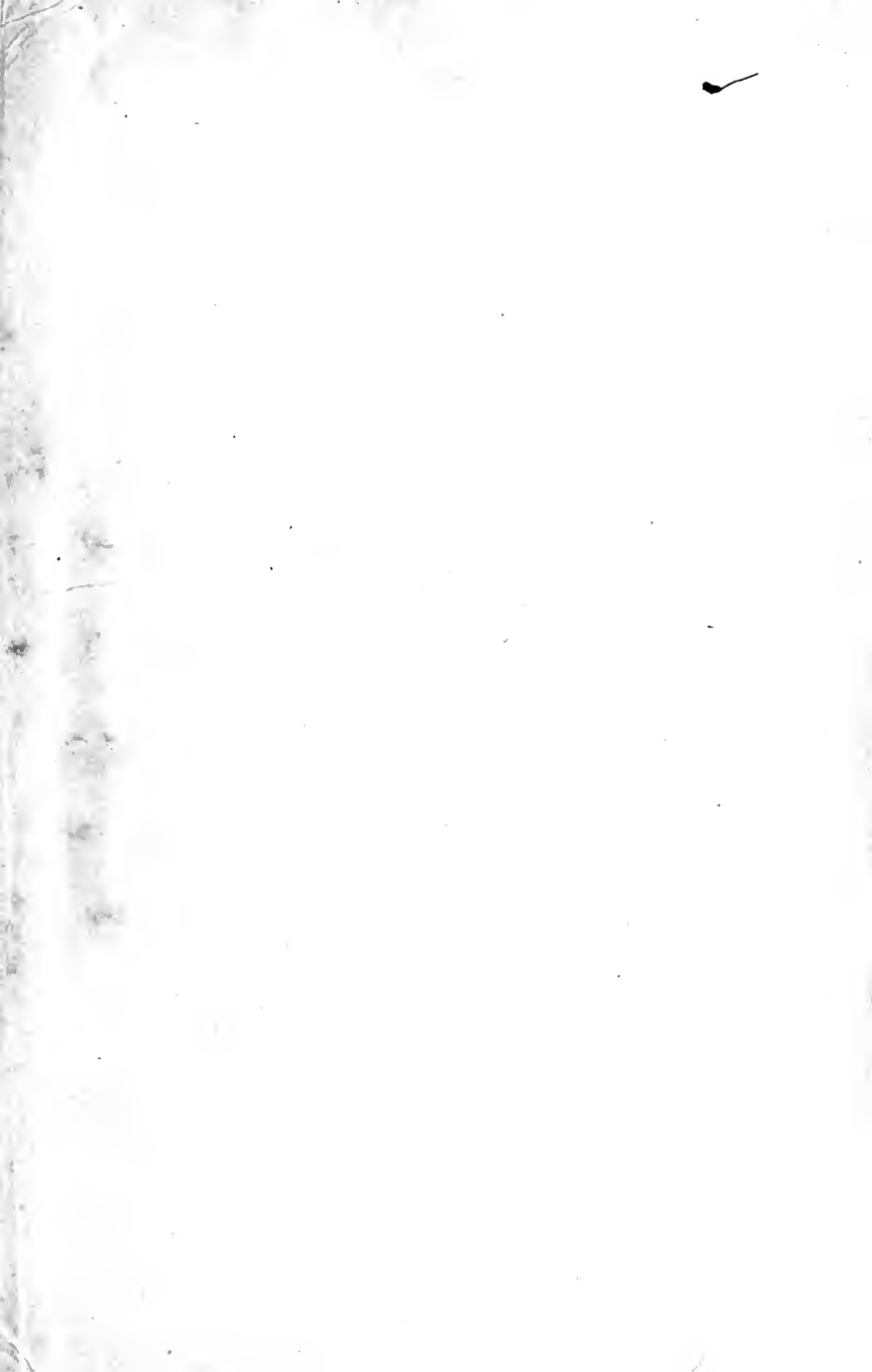

# FOURTEEN DAY USE

RETURN TO DESK FROM WHICH BORROWED

This book is due on the last date stamped below, or on the date to which renewed.

Renewed books are subject to immediate recall.

20Mar'56LM	
MAR 6 1956 LU	JUN 4 1957 M
5Apr'56GG	REC'D LD
MAR 22 1956 LU	JUN - 1 1957
<del>XXXXXXXXXX</del>	
9Apr'56LM	7Nov'60[H]
APR 2 1956 LU	REC'D LD
10Apr'56GG	
APR 2 1956 LU	OCT 25 1960
8Nov'56TS	
REC'D LD	
OCT 25 1960	
15Nov'56HJ	
REC'D LD	
NOV 1 1956	

LD 21-100m-2,'55  
(B139s22)476

General Library  
University of California  
Berkeley

0

1B 17166

QA551 202066  
S62

UNIVERSITY OF CALIFORNIA LIBRARY

