



Author

.....
.....

Title

.....
.....

Imprint

.....

Class **TS**
545
Book **.F92**





WALTHAM

WATCH PAPERS.

I.





Friedman, Charles

Isolation of bacteria from

✓
WALTHAM

WATCH PAPERS.

I.

200

1910 80

TSEK
15
: 92

ALFRED MUDGE & SON, PRINTERS,
34 SCHOOL STREET, BOSTON.

PREFATORY.

THE AMERICAN WATCH COMPANY, of Waltham, proposes to issue for gratuitous distribution to its customers and the watch trade, a series of small pamphlets, which shall contain such essays, new and old, on the theory and practice of watch making, and such selections of interesting and valuable matter from horological works and journals as may seem best suited to the end the Company has in view; namely, to excite a deeper interest in sound and scientific watch making in this country, and incidentally, by the better circulation here of the best foreign treatises on the nicer points of the art, to give and get information. The Company, as is well known, has disregarded entirely foreign precedent in its method of manufacturing, and has even released itself, by investigation and experiment, from many practices which seem to involve principles, and, as the managers think, with the best results; still, there is a vast fund of standard knowledge in foreign works, upon the basis of which all good watch making, here and there, must proceed. Additions to this stock are, besides, being constantly made and published in foreign countries for the benefit of all laborers in the art. It is to give this knowledge a freer diffusion in our own country, where comparatively little has been published upon these topics, and where each man is too often his own teacher, and, by provoking inquiry and criticism, to make some advance in the delicate business it pursues, that the Company undertakes this little publication.

The pamphlet may be the medium, too, from time to time, of any communications the Company may wish to make to its customers or the public, and will be open to correspondence and advertisements from any source related to the trade.

WALTHAM, MASS., December. 1862.

ISOCHRONISM OF BALANCE-SPRINGS.

On the Laws of Isochronism of the Balance Spring, as connected with the higher order of Adjustments of Watches and Chronometers. By Charles Frodsham, Assoc. Inst. C. E.

There is no subject connected with the science of horology, upon which such general deficiency of knowledge prevails, as that relating to the laws of the isochronism of the balance-spring, in connection with the higher order of adjustments of watches and chronometers; and, however surprising the circumstances may appear, that such is the fact, is abundantly proved by the difficulty almost universally experienced, in procuring competent assistants in the higher branches of the art. To explain these principles, and diffuse this knowledge, therefore, is the object of the present Paper, and in laying it before the Members of the Institution of Civil Engineers, the Author hopes to do justice to the talents of the watch-makers of the eighteenth century, whose numerous researches and inventions constitute the basis of all the horological knowledge possessed at the present day; for both in the best chronometers and watches, the principles of the makers of that period are still invariably followed. It is true, that the separate pieces in both, are now, by the aid of machinery and by the practical skill of the workmen, produced in a very high state of perfection: but it is not less true, that although the division of labor has contributed to insure the perfection of the parts, separately considered, horology, as a science, has not advanced proportionably: and talented individuals are become more scarce, who, by the study of its laws, are qualified for the task of seeing that all its principles are properly carried out, and the several well-made parts combined together, into a correct machine for measuring time.

To regularly educated chronometer-makers, the Author does not pretend to offer anything new, beyond the scientific investigation and explanation of the principles of the isochronal adjustment, which, in a practical point of view, must be familiar to them. Watch-makers, however, properly so called, constitute a much more numerous class than that of chronometer-makers: and, although the practical knowledge of the isochronal adjustment, is not less necessary to the former, than to the latter, at least if they aspire to the manufacture of watches of a superior class, yet few of them have attained a full knowledge of the subject, either in principle or practice. To another, and a far larger class, namely, the wearers of watches, the Author ventures to address himself, with a view to impart to them the requisite knowledge for discriminating between good and indifferent watches.

Of all the adjustments necessary in the parts of a good watch, the most essential to its performance, is unquestionably that of the isochronism of the balance spring: for, if this adjustment be wanting, whatever may be the excellence of the machine in other respects, and however labored its workmanship and other adjustments, it will assuredly disappoint the expectation of the artist, who will find it incapable of being regulated to preserve the same rate of going, in the various positions in which it is liable to be placed. An example is subjoined, illustrative of the effects of a non-isochronal spring upon an otherwise good watch.

Suppose, for instance, that by comparison with a good clock, the going of a well-made watch is tried during twelve hours, in four vertical positions, wherein the friction is much increased, and the arc of vibration of the balance considerably diminished in extent (those positions being with the hours XII, VI, IX, and III, consecutively upwards, during three hours each), and that it keeps correct time in all those positions: but that in the horizontal position, or with the face upwards, with longer arcs of vibration, the watch gains one hundred and twenty seconds in twelve hours, the friction is least in the horizontal position, and the arcs of vibration are consequently of the greatest extent.

Here then is a watch, which, though gaining considerably in the long arcs of vibration, indicates, nevertheless, a very near approximation to perfection, and by its correct performance in the verti-

cal positions, shows that the balance has been most correctly poised. The proper remedy, in such a case, is to make a correct isochronal adjustment of the balance spring. A person, however, who is unacquainted with this adjustment, would fail to discover what the true remedy should be, and would follow the plan usually resorted to, in which by lightening the balance, at the twelve o'clock part, the times of the vibrations, in the hanging and lying positions of the watch, may be accommodated to each other: but not without increasing the errors in the other three vertical positions, to the great detriment of a nearly perfect watch: thus it is that many watches, which are fair specimens of workmanship, are frequently deteriorated by false adjustments, and fail to procure for their makers, either credit or satisfaction.

Down to the middle of the seventeenth century, horology could only be considered as a mechanical art, depending entirely upon good workmanship for its excellence: but at that period, Dr. Hooke raised it to the rank of a science, by propounding its laws, and enriching it with those valuable discoveries and inventions, which rendered skilful manipulation a mere accessory, although an indispensable one, to the carrying out the governing laws and principles, which he had deduced from the highest branches of science.

The extraordinary talents of Dr. Hooke as a mechanician, cannot be too highly admired: for the improvements which, through him, were effected both in watches and clocks, do not seem to be so much the result of a happily conducted train of experiments, to which chance had directed him, as to have been elicited by acute reasoning, upon facts deduced from careful observation.

Dr. Hooke first suggested the plan of reducing the vibrations of the pendulum of a clock, within those small circular arcs, which do not differ sensibly from the cycloidal curve, and also giving such an amount of momentum to the pendulum, as should nullify the effect of any differences that might exist, in the transmission of the impulse through the medium of the train. Great, however, as were these improvements in the pendulum clock, they bear no comparison, in value and importance, with his invention and application of the balance spring to the watch, which unquestionably laid the foundation of the chronometric art: for hence-

forward this balance, with its spring, was destined to perform an office in the watch, equivalent to that of the pendulum of a clock.

Previously to this, the watch was a machine too subject to irregularities to be relied on: but it now became the model of a movable time-keeper, that by successive gradations of improvement would attain a high degree of perfection, and ultimately contain within itself, as at the present day, the capability of correcting its own imperfections, by means of certain applications of compensation and adjustment.

It is evident, that Dr. Hooke's inventive genius, which suggested to him the spiral spring, penetrated through the obscurity which concealed the laws of its isochronism from those who afterwards employed it. His expression, "As is the tension, so is the force," clearly demonstrates, not only that he was acquainted with the isochronal property of the spring, but that the correct interpretation of the phrase should have unfolded the law to others: it is, therefore, remarkable, that the spiral spring should have been employed for nearly a century, before any of his numerous followers rediscovered the means of isochronizing it.

It may be reasonably inferred, from a variety of circumstances, that Harrison was unacquainted with the isochronal property of the spiral: Arnold, however, his immediate follower, seems to have practically comprehended the subject, and while occupied in researches as to the means of lessening the difficulties of the operation, he invented the cylindrical form of balance spring and compensation balance, which were discoveries of such great importance in the progress of chronometric improvement, that they may be said to have formed the commencement of a new era in the science.

The merit of the discovery of isochronism in France, was contested by the rival artists Le Roy and F. Berthoud, by the latter of whom the subject was, among much other very valuable information, elaborately treated in his "*Traité des Horloges Marines*," published at Paris in 1773. It, however, unfortunately happens, that the artists of the present day are too little acquainted with the writings and performances of those of the eighteenth century, such as Sully, Graham, Harrison, Camus, Le Roy, Berthoud,

Ellicott, Cumming, Mudge, Arnold, Earnshaw, etc., etc. If a society of persons professing the art had been formed, and papers on the subjects connected with its improvement had been occasionally read at the periodical meetings of its members, it is impossible to say to what degree of perfection the art might now have attained, what sums would have been spared, that have been squandered in useless patents, and what valuable time saved, which has been thrown away in making researches, the results of which had been long known and amply described in the works published about that period.

One of the experiments performed by Berthoud must be mentioned, as it has been of the greatest service in enabling the variations of rate to be traced to their true causes, namely, the changes of the elastic force of the balance spring, under changes of temperature.

The diminution of elastic force in balance springs by heat, was suspected as early as 1747; as appears from the following passage in the prize essay of the celebrated geometrician, Daniel Bernoulli, read before the French Academy:

“I must not omit a circumstance which may be prejudicial to balance watches; it is, that experimental philosophers pretend to have remarked that certain changes of elastic force uniformly follow changes of temperature. If that be the case, the spring can never uniformly govern the balance.”

That which Bernoulli only conjectured in 1747, was, in 1773, established as a matter of certainty, and the amounts in loss of time, due to each of these three causes, operating conjointly were subjected to calculation and experiment by Berthoud; with the following result:

One of his marine watches in passing from 0° to 27° Reaumur (32° to 92° Fah.)—

	Seconds.
Loss per diem by expansion of diameter of balance	62
Ditto ditto by loss of spring's elastic force	312
Ditto ditto by elongation of the spring	19
	393 or 6m. 33s.

Few of the watch-makers of the present day can form an adequate notion of the difficulties which had to be overcome by the early watch-makers, on finding that their watches varied to so great an extent as six minutes thirty-three seconds in passing from 32° to 92° Fahrenheit: while a clock, with a seconds' pendulum, was known not to alter more than about twenty seconds, under similar circumstances.

Isochronism is an inherent property of the balance-spring, depending entirely upon the ratio of the spring's tension, following the proportion of the arcs of inflection; a balance spring, therefore, of any force whatever, having the progression required by the law of isochronism, will preserve this property, whether it be applied to a balance making quick, or slow vibrations: for which reason, in the present inquiry, every circumstance is purposely omitted, which gives to the balance its specific character, as weight, diameter, etc., and it is treated simply as the balance.

Writers on isochronism appear to have considered the vibrations of the balance in its totality, and to have reasoned for the most part on the times of vibrations in their entirety; but a better plan, it is submitted, would be, to consider the time of each semi-vibration of the balance, to consist of some number of very minute equal portions of time, and then by applying the known laws of forces to the motion of the balance, to determine what are the specific conditions under which the vibrations themselves shall, in their totality, be isochronous.

The elastic force of balance springs belongs to that class of forces called continuous, because the action is not by a single impulse, which then ceases; but by a number of consecutive impulses, following each other in such rapid succession, as to constitute an uninterrupted and continuous force; but which force is uniformly increasing during the bending of the spring, and uniformly decreasing whilst it is unbending.

The first step towards the comprehension of isochronism, is the recognition of the accelerated and retarded motion of the balance; for which purpose it must be followed, step by step, through the entire vibration, upon the supposition, that the time of each semi-vibration is divided into, or composed of, any convenient number of equal parts, as, for instance, ten. If then the balance be sup-

posed to be moved by the finger from the position where it will stand, when at rest, over an arc of any number of degrees, and be there held, it will be perceived, that the spring is wound into tension, and has acquired an amount of elastic force, proportionate to the angle over which it is inflected, which force is then reacting against the finger, by which the balance itself is held in a state of rest.

The instant, however, that the finger is withdrawn, the elastic force of the spring will be exerted in overcoming the absolute inertia of the balance, and at the expiration of the first short period of time (or one-tenth of the time of a semi-vibration), the spring will have communicated a slight motion to the balance. During the second tenth, the spring's force is exerted against the balance in motion, instead of being at rest, as it was at the commencement of the first tenth, and the spring will necessarily accelerate the motion that the balance had previously acquired; and so on during the third, fourth, and every other succeeding tenth, the elastic force of the spring, though continually decreasing, will be urging the balance forward, and will therefore continue to accelerate it, until the spring arrives at the position of quiescence, where it ceases further to urge the balance.

The balance having thus returned to the position of rest, from whence it was moved by the finger, the first half of the vibration is fully completed, and a change of circumstances takes place; the spring, which continued to communicate motion to the balance until now that the whole of its force has been transferred thereto, has resumed for an instant a state of quiescence. The balance has also assumed a new character, having acquired a sufficient velocity of motion and momentum, to carry it through the other half of the vibration, and in so doing to inflect the spring through an angle, equal to that which was originally moved through by the finger, and to give the spring the requisite tension for performing the next succeeding vibration. During the first few tenths of the second half of the vibration, the spring has so little tension, that its force retards but slightly the motion of the balance; but during the succeeding tenths, the tension gradually increases, until at length the spring acquires sufficient force to entirely arrest the motion of the balance, at the same extent of arc on the other side

of the place of quiescence, as that to which it was originally moved by the finger.

Diagram, Fig. 1, shows the magnitude of the several arcs, traversed by an index, affixed to the rim of the balance, during each of the successive tenth portions of the time, into which a semi-vibration of 175 degrees is conceived to be divided.

Fig. 1.
Point of Rest.

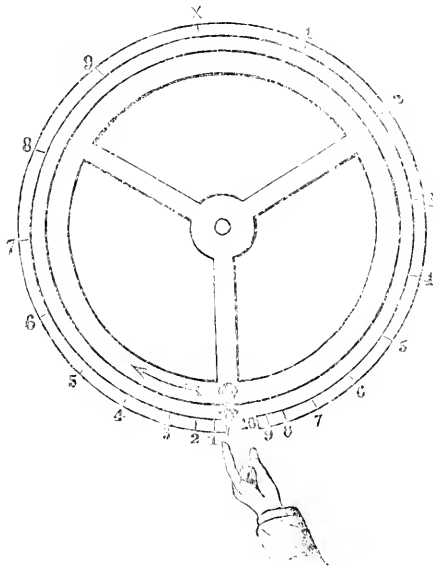

An inspection of the figure, and a comparison of the spaces described during the first and last tenth of each semi-vibration, will suffice to show that each vibration of the balance is composed of an alternately accelerated and retarded motion, and how rapidly the ratio between them proceeds, although it is not probable that the eye could detect that to be the case, even in a balance of the slowest motion.

The specific conditions under which the vibrations themselves, considered in their totality, whether long or short, should be isochronous, are these :

1st. If the time of each semi-vibration be conceived to be composed of the same number of very small equal instants of time, and, whatever be the extent of the arc traversed, that the first and last of these minute instants of time precisely correspond with the commencement and conclusion of each semi-vibration, the vibrations, whether long, or short, of such a balance, will be isochronous, or be performed in equal times.

2nd The elastic force of a balance-spring, increases in direct proportion to the angle of inflection, by which it is wound into tension; and hence it is obvious, that the increasing and diminishing tension, which causes the balance to follow a definite law of acceleration and retardation, must itself also follow some definite ratio of increase and decrease, in order that the first and last of the very small equal instants of time, shall correspond with the commencement and conclusion of each semi-vibration.

3d. It is likewise evident, that the ratio of change in the tension, may be either one which proceeds too rapidly, and, consequently, produces an operation in excess, or one which proceeds too slowly, and produces an operation in defect; on which account, there are two varieties of spring which do not produce isochronous vibrations.

4th. In the former variety, producing an operation in excess, the spring acquires a greater amount of elastic force, than that which is due to the angle of inflection in an isochronal spring; whence it follows, that the greater the arc of vibration, the greater will be the angle of inflection, and, consequently, the greater the excess of undue tension. The effect of this undue tension will be, to hurry the balance forward during the first half of the vibration, with too great celerity, and thus cause it to arrive at the conclusion, before the complete number of minute instants, due to the isochronous vibration, has expired. A similar effect is produced during the second half of the vibration, by the undue excess of tension arresting the balance, before the full number of instants has entirely expired. During each semi-vibration, therefore, throughout the day, some of these minute instants will be left unemployd, and their accumulation will be the amount gained in the long arcs of vibration, in comparison with the performance of the same watch in the short arcs.

5th. In the latter variety, the elastic force due to the angle of inflection will not be sufficiently great, and the spring will not have the requisite tension to carry the balance over the first semi-vibration of a long arc, in the number of instants allotted to it, nor to arrest it so soon as the isochronous term of the second semi-vibration requires. Each semi-vibration, therefore, will occupy too large a number of instants in its performance, and the accumulated amount of them, throughout the day, will indicate the loss during the long arcs of vibration, in comparison with the performance of the same watch in the short arcs.

It is evident, that however great may be the science displayed in the application of a balance-spring, it will be valueless in a chronometrical point of view, if it will not remain permanently in the state in which the artist leaves it. For a spring to possess this indispensable property, a high degree of perfection is, necessarily, required, demanding care in the selection of the material, skill in the manufacture, and science in the application.

Balance-springs are, for the most part, made of steel, hardened and tempered, though some few have been made of gold, of which metal certain alloys have been particularly recommended; but their elasticity is not always to be relied on. The use of glass for springs was suggested by Berthoud, but was, ultimately, rejected.

Balance-springs must possess as perfect and as permanent a degree of elasticity as can be attained. These requisites depend upon the quality, hardness, and temper of the metal, as well as upon the form or shape of the spiral. A soft spring gradually changes its form, and, losing a portion of its elastic force, becomes defective, and unfit for employment in a watch of the slightest pretensions, owing to the constant losing on its rate. A hardened and tempered spring, on the contrary, has a tendency to gain on its rate: but this must not be considered as a defect, since it is merely the result of the laminæ of the spring having been set in the process of hardening, whereby it has acquired an adventitious degree of rigidity. This rigidity, however, wears off after a few months' vibration in the watch, which during this period almost imperceptibly accelerates a little upon its rate, on account of the acquisition of the minute increments of additional

elastic force occasioned by the gradually increased flexibility of the spring. When, however, the processes of hardening and tempering have been properly conducted, the gaining on the rate will be restricted within very narrow limits, and will soon cease, on the springs' attaining its maximum amount of flexibility and elastic force.

Correctness of form, or shape, has been already stated as one of the conditions requisite to insure isochronism. There are two forms of springs in use, namely, the cylindrical, or helical spring, and the spiral, or flat spring; the former is exclusively employed in chronometers, and the latter in all other kinds of watches.*

The simplest form of spring is the helical, cylindrical. This spring is formed into a coil of a certain number of rings of equal diameter, rising one above another, in the form of a cylinder. The lower end of the spring is turned in by a suitable curve to accommodate it to the size of the collet, into which that end is fixed; and the upper end of the spring is turned in by a more or less bold sweep, according to the indications of the isochronal adjustment, and is pinned into a fixed stud.

The collet vibrating with the balance, that point in the circumference of the collet where the spring is pinned into it, is inflected through the same extent of arc as the semi-vibration consists of; and by examination of the action of the spring, during the vibration of the balance in the chronometer, it will be perceived, that for each portion of the extent so inflected, there is a corresponding increase, or diminution of each of the coils of the helix, throughout the entire length of the spring, no part whatever being out of action during any portion of the vibration.

* Writers mention a third, or spherical form, which is stated to be better adapted for isochronous vibrations; but it needs the testimony of more numerous experiments and stronger evidence than has been hitherto adduced, to prove that chronometers with spherical springs are superior to those with cylindrical springs, of which so many fine specimens, by various makers, are now in constant use. It may likewise be observed, as a proof, that the flat spring is capable of the same degree of perfection as the cylindrical, that the Author's prize chronometer, No. 1, which has never been surpassed by any chronometer on record, had a flat spring. This chronometer, during a trial of twelve months' duration at the Royal Observatory, at Greenwich, was found by actual daily observation to have made an extreme variation of only fifty-seven hundredths of a second.

In order to try the isochronism of a spring, the chronometer must be ready and in going order. If the force of the main spring be then increased by setting up the ratchet, the arc of vibration of the balance will be extended; or if the force of the main spring be diminished by letting down its ratchet, the arc will be lessened; the arc of vibration may therefore be regulated to any extent desired. Comparisons of the chronometer's rate of going, during an equal number of hours, in the long and in the short arcs of vibration, are then to be made by a good clock, and the difference, if any, carefully noted. This difference indicates the state of approximation of the spring to isochronism, and points out the remedy, if it needs correction, according to the following rules:

Case 1st. If the chronometer be found to lose in the long arcs, it will prove that the tension, or elastic force of the spring, has not increased to the amount due to the angle of inflection, or semi-arc of vibration. Hence, some minute portions of time are lost in each semi-vibration; in the first semi-vibration, the balance not being carried forward with sufficient celerity, so as to arrive soon enough at its term; and in the second semi-vibration, by the spring not acquiring the requisite amount of force soon enough to stop the balance, at the expiration of the number of instants due to the isochronous semi-vibration.

The remedy in this case is to shorten the spring, and thereby to cause the progression of the increase of its elastic force to become more rapid; but, as much time is lost by repeatedly unpinning the spring, the effect of shortening may be produced artificially, when the state of the isochronism is within the limits which experience points out, by merely altering the form of the upper curve, so as to give it a greater degree of expansion.

Case 2d. If the chronometer is found to gain in the long arcs, in comparison to the time it keeps, when vibrating in short arcs, it will prove, that the tension increases in a ratio beyond that which is due to the angle of inflection. In this case, if the chronometer keeps time, when the semi-arc of vibration is one hundred degrees, it will gain when it is made to vibrate two hundred degrees; for, instead of having so much force as would compel the balance to vibrate over double the space with a double

mean velocity, which would of course occupy the same time, it will possess an excess of tension, which will increase the velocity of each of the semi-vibrations, and necessarily abridge the time of performing them, and thus cause an accumulation of small instants, which will be the gain per diem.

The remedy, in such a spring, is to increase the length of the part in action: but as this is not always convenient, or possible, the isochronal adjustment is resorted to, in which a kind of artificial length is given to the spring, by compressing the curve of the part bent inward at the upper end, so as to make the curve commence its inward direction at a point a little farther distant from the stud.*

Before attempting to make any alteration in a spring, it is advisable to examine the state of the curves, more especially when the chronometer gains in the long arcs, as it will sometimes be found, that one or other of the curves is turned in too abruptly, which has the effect of causing a gain in the long arcs, in consequence of the spring abutting so directly against the curve, as to leave a part of its length in very imperfect action.

The opinion of the early writers upon isochronism, was, that a certain determinate length procured an isochronal spring: but the fact is, that in every length of wire there are several isochronal points, to either of which a balance may be adapted, according to the nature of the vibrations it is intended to perform. Suppose, for instance, that a cylindrical spring, having ten turns, be found isochronal, one or more of these turns may be taken away, and a point in the spring still be found, that will give the required ratio of increasing tension, and produce isochronous vibrations.

The spiral, or flat spring, is less simple in its form than the cylindrical spring: and although whatever be the form, the principles upon which its isochronism depends are not altered, yet there are circumstances which affect its isochronal perfection in so material a degree, that they require to be particularly noted; and the more especially so, since the spirals are more commonly

* The old methods of tapering the spring, or thinning the upper or under turn, to make the increase of tension observe the proper ratio, are never now resorted to by experienced makers.

employed than the cylindrical springs, while the construction of the former involves several points of great nicety in the manipulation.

The proper length and strength of wire being well selected, the manner in which it is turned up into a spiral is important, for in this operation its natural isochronism may be either partially or wholly destroyed. This will especially happen if there be any small points, or elbows in it : or if the spring be so made, that during the vibration, any part thereof be either inactive, or have an imperfect action. Indeed, the absolute necessity for the spring to continue in free and unrestrained action throughout its entire length, and during the whole period of the vibration, cannot be too strongly urged : because, an opinion generally prevails, that the outer turns do not come into action until near the end of the semi-vibrations.

With the cylindrical spring, there is no great difficulty in producing the same extent of vibration on either side of the point of quiescence : with a flat spring, however, this is not attained with an equal degree of facility, nor without close attention to its form, as well as to the mode of pinning it in, so that it be not in the slightest degree strained from its natural shape, or position, when out of the watch.

A spiral, to be turned up correctly, should lie in several close turns towards the centre (Fig. 2), springing off from where it is pinned into the collet, by a gentle curve, and thence gradually and constantly expanding, in such a manner that each part of the spiral would cross, but nowhere coincide with a small circular arc drawn from the centre of the collet and concentric therewith. This is indispensable to isochronism.

Fig. 2.

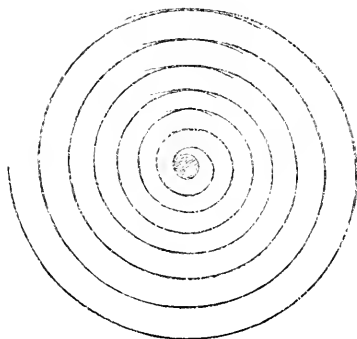

If, on the contrary, a spiral springs off from the collet, first by a large bold sweep, and then lies in a few close and large turns, it will be very defective in its action, and quite devoid of the isochronal property. In such a spring, the middle of the vibration will not coincide with the point of quiescence; for the spring will readily yield to the momentum of the balance, during the winding up, and contraction of its coils, and the whole length of the spring will be brought into action, though imperfectly: but, during the expansion of the coils upon the return of the balance, the action of the inner turns will not be exerted against curves which lie across concentric circles, as in the diagram, but against such as lie in concentric circles, or very nearly so, and will therefore abut so point-blank against them, as to cause no displacement whatever in a portion of the outer turn: thus giving the effect of a short strong spring, which arrests the balance too soon in this part of the vibration. Such irregularities are obviously quite incompatible with the requisites for producing isochronous vibrations.

The isochronal trial of a flat spring in a watch, is more simple than that described for the chronometer, since the balance for the watch is thrown into the long, or short arcs of vibration, by the mere change of position, which varies the amount of friction, and consequently the extent of the arc. In the horizontal position, with the face uppermost, the friction is least, and the vibrations are of the fullest extent: in the vertical, or that in which the watch is worn, the friction is greatest, and the extent of the vibration is necessarily curtailed. The trial is made, with the aid of a good clock, by comparing the rate of performance during a certain number of hours, in a horizontal position, with the mean result of an equal number of hours' performance in any two opposite vertical positions: for instance, first with the XII. and then with the VI. upwards, and then in the like manner with the IX. and III.: the mean result of two opposite vertical positions being required, in order to neutralize the effect of any slight irregularities that may exist in the poise of the balance. The indications and the application of the isochronal adjustment, are the same as those already described for cylindrical springs, but under greater restrictions. For, as the balances for watches are, for the most part, simple and unprovided with any means by which their inertia

may be varied, as is done in the compensation balance, so as to suit the elastic force of any particular spring, and the number of vibrations required to be performed in a given time, the spiral of a watch must not only be isochronal, but be of the precise degree of elastic force demanded by the particular balance to be employed.* The selection of a spring, within the limits of the isochronal adjustment, must therefore be made by trial in the watch.

The great advantage of an isochronal spring, in its innate power of resisting the influences which cause a change of rate, such as the change of position, increased friction as the works become dirty, or the viscosity of the oil in low temperature.† Indeed, it is surprising to see chronometers return from sea with scarcely a change of rate, although some of them had been going for three or four years, and even for longer periods of time, and the vibrations had fallen off to a very small arc, in consequence of the oil becoming so viscid, that, in some instances, a slight degree of force has been required to draw the pivot out of the fourth wheel-hole. But what was still more remarkable, some of these chronometers, after being cleaned, had been observed to take up their original rate, even perhaps with a threefold amount of vibration.

The mode by which an isochronal spring arrives at such perfection, may be thus explained: The spring's elastic force is presupposed to be both perfect and permanent, under similar temperatures; for, as has been previously stated, the elastic force diminishes, as the temperature to which it is exposed is increased.

The elastic force of the spring is counterbalanced by the resistance it meets with, in the work it has to perform: this is of two kinds, the inertia of the balance, and the friction of the rubbing parts, from a certain amount of which no machinery is exempt.

If the spring is assumed to possess a force equal to 100, and that 10 of these parts are requisite to overcome the friction, when

* A compensation balance is sometimes applied to a lever watch, with the design to render it a more perfect instrument; but that cannot be attained, unless due regard be had to the isochronism of the spring, as will be understood from what has been already stated.

† Watches of excellent workmanship occasionally come into the Author's hands, with considerable errors in the long or the short arcs of vibration; yet they require nothing more than the isochronal adjustment to render them, what their makers intended, good watches.

at a minimum, there will be 90 parts left, for action upon the balance. But the friction will vary according to circumstances, although the spring and balance may remain unaltered. If, therefore, the spring has power to carry the balance through a circle of vibration, when the friction is at a minimum, it will have power to perform the same amount of work when the friction is at a maximum, but the 100 parts of force will be differently apportioned in the execution of the task.

Let it be assumed, for instance, that the friction is trebled; there will then be 30 parts employed in overcoming the friction, and consequently 70 parts only for action upon the balance, which will necessarily have a less extent of vibration. Now, since the isochronal ratio of the spring's tension remains unaltered, the beginning and end of each semi-vibration will still coincide with the first and last of the minute instants of time, composing the isochronous vibration, which is the condition that is required for correct performance.

So likewise it is with increased friction in watch-work, the elastic forces of the balance spring being constantly proportioned to the angle of inflection, whatever the amount of friction, the law of isochronism remains unchanged, and friction is only an adventitious circumstance, which affects the extent of the arc of vibration, but not the time in which it will be described.

Mr. FAREY considered the Paper to be of a class highly deserving of the attention of the Institution, for although the subject did not come within the ordinary course of engineering studies, nevertheless it involved principles of mechanical action, with which all engineers ought to be well acquainted. The application of those principles in the construction and operation of marine chronometers, had been attended with a degree of precision in performance, greatly exceeding all that could be required in machines for the performance of forcible operations: those being the machines with which engineers were most conversant, and which they had brought to a high degree of perfection, as regarded power, strength, and rapidity of operation, in overcoming resistances, with capability of continuing their operation without ceasing, as long as might be required.

It was a useful exercise of mind, to turn the thoughts occasionally from their habitual course, to the consideration of subjects, wherein similar principles had been applied with success, for the attainment of very different objects; and it was one advantage of the Institution, that it brought together persons who had acquired skill in many different pursuits, having but little in common, except that they were all applications of mechanical science, and were dependent on the correctness of such applications for their success and their progress towards perfection.

Chronometers required far more precision in their motions, than any other machines, and the perfection to which they had been brought, rendered the principles of their construction an interesting study, and a correct knowledge of the very minute circumstances on which that perfection was dependent, could not fail to be useful. Mr. Frodsham's paper explained, that isochronism of the vibration of the balance was a most essential qualification for correct performance in a chronometer, and that with some particular length and other conditions of its balance-spring (only to be found by trial in each case), the requisite equality of the times of long, or short arcs of vibration of the balance, might be attained.

It was generally admitted as true in theory, that a spring which exerted an uniformly increasing force, in being bended during the motion of the balance through equal arcs, and an uniformly decreasing force in unbending itself, and returning the balance through the same arcs, would produce the required regulation. As an illustration of this, the chronometer might be supposed to be placed with its balance in a vertical plane, and a very fine hair to be fastened to its rim, and after passing around its circumference, descending vertically therefrom in the direction of a tangent, so that any weight which might be appended to the hair would move the balance some way round from its quiescent position, and in so doing would bend its spring, until the increasing force thereof becoming equal to react against the weight, the balance would then stop at some angle from its quiescent position. If the spring were correctly formed, the extent of such angle should be proportionate to the weight (*ut tensio sic vis*, as Dr. Hooke expressed it). So that supposing the weight to be one grain, and that it had moved the balance through an angle of 20 degrees, then the addition of another grain should

move the balance another 20 degrees; and so on, each increment of one grain of force should produce an increment of 20 degrees of angular motion of the balance; and therefore 10 grains of force would move the balance through ten such increments of 20 degrees each, or an angular motion of 200 degrees from the quiescent position, that being about an average extent of the semi-vibration of the balance in chronometers. The same mode of trial should be supposed to be repeated, with the hair passed in a contrary direction over the circumference of the balance, and ought then to show the same results as before; thereby proving, the force of the spring to be the same, whether it was being wound up in the direction of its coils, or being unwound in a contrary direction. Such a condition of spring having been attained, in any watch or chronometer, the vibrations of its balance would (according to theory) be performed in an equal space of time, whether they were of a longer, or shorter extent. Therefore a chronometer newly cleaned and oiled, being adjusted to keep time correctly, with its balance vibrating full one turn and a quarter (or 225 degrees for the semi-vibration) ought not to alter its rates of going as the vibrations became diminished, in the course of constant use without oiling, even though they should be reduced to less than one turn (or 175 degrees for the semi-vibration).

The attainment of such an amount of isochronism was also of importance for pocket watches, although they did not require the precision of chronometers: because, in addition to continuing to go well as the works became dirty, *the fusee and chain for the main-spring might be dispensed with in the construction of the watch, and the diminution of the vibrations, attendant on the diminishing force of the main-spring, during each twenty-four hours, should make no difference in the going of the watch.*

The progressive motion of the balance, during its semi-vibration, in returning from one extremity of the vibration to the quiescent, or midway position, was an accelerated motion: and in proceeding onwards through the opposite semi-vibration beyond the midway position to the other extremity of the vibration, it was a retarded motion: but the acceleration would not take place by the same law as that of falling bodies, because gravitation (practically speaking) was an uniform and constant force, which

gave to falling bodies equal increments of velocity in equal times, which was termed uniformly accelerated motion; whereas the force of the balance spring was uniformly decreasing, and could not therefore produce so rapid an increment of velocity as uniformly accelerated motion.

Although the theory that isochronal vibrations must result from a uniformly increasing and decreasing force of the spring, might be admitted, yet, in practice, it was necessary that the spring should be adjusted, so that the law of its force would be accommodated to suit all other circumstances, which could interfere with the freedom of the vibration of the balance, the resistance of the air being one of those circumstances: and in compensation balances which had screws projecting from their circumferences, with large heads to serve as weights, the resistance to their motion through the air must be considerable: but that resistance increasing as the squares of the velocity, it could not occur with the theoretically assumed uniformity of increasing and decreasing force of the balance spring, to allow of the isochronal vibrations, which it was admitted in theory, would result from such uniformity.

The usual practice was to adjust to chronometer to go well, when its balance vibrated to a full extent of one revolution and a quarter, and then by letting down the main-spring by its ratchet the impelling force was so diminished that the balance would not vibrate more than three-fourths of a revolution; it was then expected that the chronometer would go as well as it did at first, and if it did not, the spring of the balance was altered in its length, or in the curvature of its ends, in the manner described in the paper, until by repeated trials and alterations the chronometer was made to go at the same rate, whether the balance vibrated the full extent, or the diminished extent.

This mode of trial was assumed to be an anticipation of what would afterwards take place, when the chronometer was in use on a long sea voyage, where it was found, that the extent of the vibrations of the balance diminished in proportion to the time the chronometer continued in use. But it might be doubted, on close examination of all the circumstances, whether those of the previous trials, and those of the future use, were on a parity.

Because when the maker reduced the extent of the vibrations for his trials, he did so by diminishing the impelling force that was imparted to the balance, without altering the resistance to the motion of the balance. Whereas in long service, the resistance to the motion of the balance became increased by the gradual thickening of the oil about its pivot, and that increased resistance was the chief cause of the diminishing extent of the vibrations.

It was true that the oil in the wheelwork of the train would also thicken, and diminish the force with which the escapement wheel would impel the balance, so that both causes would be in operation, to diminish the extent of the vibrations, viz., greater resistance to motion, and less force of impulsion to overcome resistance, and produce motion; but the influence of the thickening of the oil would be much greater, to increase the resistance to the motion of the balance, than to diminish the impelling force of the train of wheelwork, because the friction of the pivots of the balance was caused by a very considerable motion between the rubbing surfaces, although attended with a very slight force of pressure: hence the viscosity of the oil, which was applied to those rubbing surfaces, would greatly augment the resistance to motion; whereas the friction of the wheelwork of the train was caused by a very small motion between the rubbing surfaces, attended with a considerable force of pressure, and an equal viscosity of the oil, would not diminish the impelling force of the wheelwork, in the same proportion as the resistance to the motion of the balance was increased. The trials which were made for adjusting the isochronism of the balance-spring of a chronometer, would be more assimilated to the circumstances of its future use, if a temporary friction could be applied, to retard the motion of the balance, as, for instance, by applying thick gummy oil to its pivots, or by means of a slender spring pressing laterally against the axis of the balance, and thereby reducing the extent of its vibrations, without depending entirely upon reduction of the impelling force of the main-spring and wheelwork for reducing that extent; but both means might be resorted to, either separately, or in combination, for making the trials.

It was stated in the Paper, that the friction of the balance did

not alter the isochronism of the spring, when it had been fully attained. That might be the case, whilst the chronometer remained in the hands of the maker, after he had adjusted the spring by trial and error, as was described in the Paper: because that adjustment, from the mode of making it, would compensate for the effect of all the difference of friction that must exist, when the motion of the balance was greater, or less, in the case when the diminution of the motion resulted solely from a reduction of the impelling force. But after the chronometer had been long in use at sea, and such diminution would chiefly be the result of increased resistance to the motion of the balance, from the thickening of the oil, there might be some doubt, whether the usual mode of making the adjustments would suit the future circumstances as accurately as was desirable.

The conditions under which a spring would produce isochronal vibrations of the balance were not well understood, although the result was arrived at by trial and error, as described in the Paper. An equality of flexure of every part of the spring throughout its whole length, if not a necessary condition, was no doubt very important, and would result most naturally from a tapered form of the spring, which was formerly given by working the steel for the spring thinner towards each of its ends. And although Mr. Earnshaw attributed much of the perfection of his chronometers to such tapering, it had not been continued, which might be because the tapering was very liable to be irregularly performed, and in such cases the superior accuracy of springs of uniform thickness would entitle them to a preference.

Mr. Frodsham said there was no subject connected with horology, which had been the cause of so much loss of time, and waste of money and talent, as the prevailing want of knowledge of the laws of isochronism. Perfection of mechanism alone was incapable of insuring a correct time-keeper, or the detached escapements of Arnold and Earnshaw, which were models containing every requisite, would long ago have offered to the careful imitator, the means of producing perfect chronometers. But no mechanism, however correct in itself, unless under the influence of an isochronal spring, would produce a good result; and persons who were unskilful in obtaining isochronism, had resorted to

a variety of mechanical schemes to obtain arcs of uniform extent, and, as they hoped, of uniform duration. The remontoir escapement was one in which, with much loss of power, a sort of secondary mainspring was wound up at short intervals, by the power of the primary spring. By this transfer of agency, all the errors of the mainspring and train were expected to be avoided, and it was argued, that as the impulse given to the balance would be constant and uniform, the arcs of vibration must, of necessity, be of uniform extent, and therefore of uniform duration; but it might easily be proved that one was not a necessary consequence of the other. There was, nevertheless, something so plausible in the remontoir escapement, that several talented men had labored to improve its construction, in a manner that did their perseverance the highest credit; for instance, Mudge, who effected the winding up of the remontoir spring, at every half vibration, and it was to be regretted that so much zeal, talent and industry, should have been spent in fruitless research.

The chronometer constructed with the Arnold escapement, contained adjustments for all the contingencies which it is liable to meet with at sea, and his late instruments were adjusted upon the simple isochronal principle, to maintain a uniform rate, in every variety of position; notwithstanding they might occasionally fall off in their vibrations, to the extent of ninety degrees. How then could Mr. Farey's setting up the main-spring be accomplished, or what necessity could there be for it, when the isochronal adjustment provided most perfectly for every change? *It would be difficult indeed for an experienced hand to hazard any attempt at the adjustment of a chronometer at sea, when it was considered that a variation of one degree of Fahrenheit's thermometer produced in an uncompensated watch, an error of six seconds per diem.*

Mr. Farey's remarks were exceedingly valuable, as to whether the mode adopted in reducing the arcs of vibration during trials, was really upon a parity with what took place by the thickening of the oils, after being at sea for a long period: but Mr. Frodsham's experience led him to believe that the adjustment had been found sufficient.

The plan of tapering the springs was abandoned, because it

was impossible to produce isochronism, under all circumstances, with a spring so made. In a chronometer it might be used, without detriment, nevertheless it distorted the action of the helical spring, whilst to the flat, or spiral spring, it gave a pleasing appearance during action: but when applied to the best lever watches it invariably produced a losing effect in the short arcs of vibration, amounting sometimes to one hundred and eighty seconds per diem. The plan was moreover unnecessary, because a more beautiful action of the spring might be obtained by bringing the outer turn of the spiral round, and pinning it in over the centre of the collet, or by a flexible stud: as no error, however, arose from the throw of the spring, it was best pinned into a fixed stud.

Among the causes which affected the extent of the arcs of vibration, were the dirty state of the watch, the thickening of the oil, and the falling-off in the power of the mainspring, which latter was sometimes as much as half its original force: yet if the balance-spring was isochronal, deviation from the original rate was generally found to be inconsiderable, even in such an extreme case.

The lever watch was the most useful description of pocket watch for general wear: yet as ordinarily constructed, it was well known to be very uncertain in its performance, and commonly lost in the short arcs of vibration (or vertical positions), to the extent of from one to four minutes per day. The curtailment of the vibrations and the throwing the balance out of poise, so as to accommodate the hanging and lying positions to each other, were usually resorted to: whereas by the application of an isochronal spring, and a well-poised compensation balance of extended vibrations, excellent results might be obtained for pocket watches; this should be generally known, because so much perfection had not hitherto been thought within the capabilities of the lever escapement. Few persons, except those who were in the constant habit of seeing the timing of chronometers under adjustment, could be aware of the difficulties attending the task: and the wonder was, as an Astronomer Royal had remarked, that they "went so long and so well as they did."

Another difficulty existed in the process of hardening and tem-

pering the balance-spring, which was one of the most delicate operations connected with chronometry, and in which a few degrees difference in the temperature of the water into which it was plunged caused a difference in the state of hardness; nor did the subsequent tempering obviate the effects to be observed, in the amount of gaining upon the rate of the instrument, which resulted from such hardness.

We also append the following Table of Trains, by Charles Frodsham, showing that, with the same main-spring and the same balance-spring, nearly 70 different characters of balance may be used, by changing the velocity per minute, as per Table, which has a range of from 240 to 400 vibrations per minute.

All have the same momentum, and the same mean vibration between the hanging and lying position; the arc of vibration agreeing more and more closely in the horizontal and vertical positions as the velocity per minute increases; for, as a general rule, you cannot vary the diameter and keep a constant weight. It must also be well understood, that when we speak of momentum, it always has reference to the work done by a given main-spring and balance-spring, driving a balance of a certain diameter and weight a definite number of times in 60 seconds of mean time, through an arc of vibration which is a correct mean between the horizontal and vertical positions, during an equal number of hours in each position. Thus, if a given main-spring and balance-spring carry a balance whose diameter is 0.65 inches and weight 9 grs. through a certain arc of vibration 270 times per minute of mean time, the same main-spring and balance-spring will carry a balance of 0.65 in. diameter and 4.10 grs. weight 400 hundred vibrations per minute. But, if we prefer weight to diameter, then we can only use 0.44 inches diameter with a weight of 9 grs.

From the above it will be seen a variety of changes can be made, the law being that the weight be increased or diminished in the inverse ratio of the square of the diameter, the square of

the number of vibrations per minute, or the square of the number of degrees in the arc of vibration.

The most useful trains are:—for lever escapements, a velocity of 270, 280 and 288 per minute; for marine chronometers, 240, the well-known half second beat; for duplex, 300 per minute; for pocket chronometers, 300 to 320.

The question may probably arise, is there any time-keeping quality in any particular train? None, or very little, except in extreme cases. Thus, for a stationary instrument (like the ship chronometer) the slow half second train is preferred; but this would be quite impracticable in a watch that is to be carried in the pocket, as the balance-spring would not probably control its motion; besides which, the arc of vibration in the horizontal and vertical positions, would disagree to too great an extent.

On the other hand, in very high velocities, the properties of the balance are lost by the diminished weight or diameter, or both, and the balance has a constant tendency to be overmastered by the spring and be brought to rest.

ISOCHRONISM OF BALANCE-SPRINGS.

GENERAL TABLE OF TRAINS.

From 240 to 400 vibrations per minute.

The measures are in 100ths of an in. and the weight in grs.

The arc of vibration is constant, one turn and a half.

Vibrations.			Vibrations per second.	Escapement wheel teeth.	Ratio of escapement pinion to 4th wheel.	Dia. constants.	Weight variable in grains.	Weight constant. Dia. variable in hundredths.	Both variable.		Balances.	
Per hour.	Per min.	Per sec'nd.							Wt.	Dia.		
14,400	240	4	4 v. = 1 ^u	12	1 to 10	65	11.34	9	73	10 1/2	68 1/2	} D. 68 1/2 W. 10 1/2 grs.
"	"	"	"	15	1 " 8	65	11.34	9	73	10 1/2	68 1/2	
"	"	"	"	16	3 " 15	65	11.34	9	73	10 1/2	68 1/2	
"	"	"	"	18	3 " 20	65	11.34	9	73	10 1/2	68 1/2	
"	"	"	"	20	1 " 6	65	11.34	9	73	10 1/2	68 1/2	} B. 65 W. 9 grs.
15,000	250	4 1-6	25 v. = 5 ^u	15	3 " 25	65	10.48	9	70 1/2	9 1/2	67 1/2	
15,120	252	4 1-5	21 v. = 3 ^u	14	1 " 9	65	10.32	9	69 1/2	9 1/2	67 1/2	
"	"	"	"	18	1 " 7	65	10.32	9	69 1/2	9 1/2	67 1/2	
15,360	256	4 4-15	61 v. = 15 ^u	16	1 " 8	65	10.00	9	68 1/2	9 1/2	66 1/2	} B. 65 W. 9 grs.
15,600	260	4 1-3	13 v. = 3 ^u	13	1 " 10	65	9.70	9	67 1/2	9 1/2	66 1/2	
"	"	"	"	20	2 " 13	65	9.70	9	67 1/2	9 1/2	66 1/2	
15,660	261	4 7-20	87 v. = 20 ^u	18	4 " 29	65	9.62	9	67 1/2	9 1/2	66 1/2	
15,840	264	4 2-5	22 v. = 3 ^u	18	3 " 22	65	9.40	9	66 1/2	9 1/2	65 1/2	} B. 65 W. 9 grs.
*16,200	270	4 1-2	9 v. = 2 ^u	15	1 " 9	65	9.00	9	65	9	65	
"	"	"	"	18	2 " 15	65	9.00	9	65	9	65	
16,320	272	4 8-15	68 v. = 15 ^u	16	2 " 17	65	8.87	9	64 1/2	9	64 1/2	
16,560	276	4 3-5	23 v. = 5 ^u	17	1 " 8	65	8.87	9	64 1/2	9	64 1/2	} D. 61 1/2 W. 8 1/2 grs.
16,800	280	4 2-3	14 v. = 3 ^u	15	3 " 23	65	8.60	9	63 1/2	8 1/2	64 1/2	
"	"	"	"	16	4 " 35	65	8.56	9	62 1/2	8 1/2	63 1/2	
"	"	"	"	20	1 " 7	65	8.36	9	62 1/2	8 1/2	63 1/2	
17,280	288	4 4-5	24 v. = 5 ^u	16	1 " 9	65	7.90	9	61	8 1/2	62 1/2	} D. 61 1/2 W. 8 1/2 grs.
"	"	"	"	18	1 " 8	65	7.90	9	61	8 1/2	62 1/2	
17,340	289	4 49-60	259 v. = 30 ^u	17	3 " 17	65	7.85	9	60 1/2	8 1/2	62 1/2	
17,400	290	4 5-6	29 v. = 6 ^u	15	3 " 29	65	7.80	9	60 1/2	8 1/2	62 1/2	
18,000	300	5	5 v. = 1 ^u	12	2 " 25	65	7.28	9	58 1/2	8 1/2	62 1/2	} D. 61 1/2 W. 8 1/2 grs.
"	"	"	"	15	1 " 10	65	7.28	9	58 1/2	8 1/2	61 1/2	
"	"	"	"	16	8 " 73	65	7.28	9	58 1/2	8 1/2	61 1/2	
"	"	"	"	18	3 " 25	65	7.28	9	58 1/2	8 1/2	61 1/2	
18,440	304	5 1-15	76 v. = 15 ^u	16	2 " 19	65	7.10	9	57 1/2	8 1/2	60 1/2	} D. 55 W. 7 1/2 grs.
18,330	303	5 1-10	51 v. = 10 ^u	18	2 " 17	65	7.00	9	57 1/2	8 1/2	60 1/2	
18,600	310	5 1-6	31 v. = 10 ^u	15	3 " 31	65	6.83	9	56 1/2	8	60 1/2	
18,720	312	5 1-5	26 v. = 5 ^u	18	3 " 23	65	6.73	9	56 1/2	8	59 1/2	
19,200	320	5 1-3	16 v. = 3 ^u	15	3 " 32	65	6.40	9	54 1/2	8	58 1/2	} D. 55 W. 7 1/2 grs.
"	"	"	"	16	1 " 10	65	6.40	9	54 1/2	8	58 1/2	
"	"	"	"	20	1 " 8	65	6.40	9	54 1/2	8	58 1/2	
19,440	324	5 2-5	27 v. = 5 ^u	18	1 " 9	65	6.23	9	54 1/2	8	57 1/2	
19,680	328	5 7-15	82 v. = 1 ^u	16	4 " 41	65	6.10	9	53 1/2	7 1/2	56 1/2	} D. 55 W. 7 1/2 grs.
20,400	340	5 2-3	17 v. = 3 ^u	17	1 " 10	65	5.67	9	51 1/2	7 1/2	56 1/2	
"	"	"	"	20	4 " 34	65	5.67	9	51 1/2	7 1/2	56 1/2	
21,000	350	5 5-6	35 v. = 6 ^u	20	4 " 35	65	5.36	9	50 1/2	7 1/2	55 1/2	
21,600	360	6	6 v. = 1 ^u	20	1 " 10	65	5.06	9	48 1/2	7 1/2	54 1/2	} D. 55 W. 7 1/2 grs.
22,800	380	6 1-3	19 v. = 3 ^u	20	2 " 19	65	4.55	9	46 1/2	7 1/2	52 1/2	
24,000	400	6 2-3	20 v. = 3 ^u	20	1 " 10	65	4.10	9	44 1/2	6 1/2	50 1/2	

* Model.

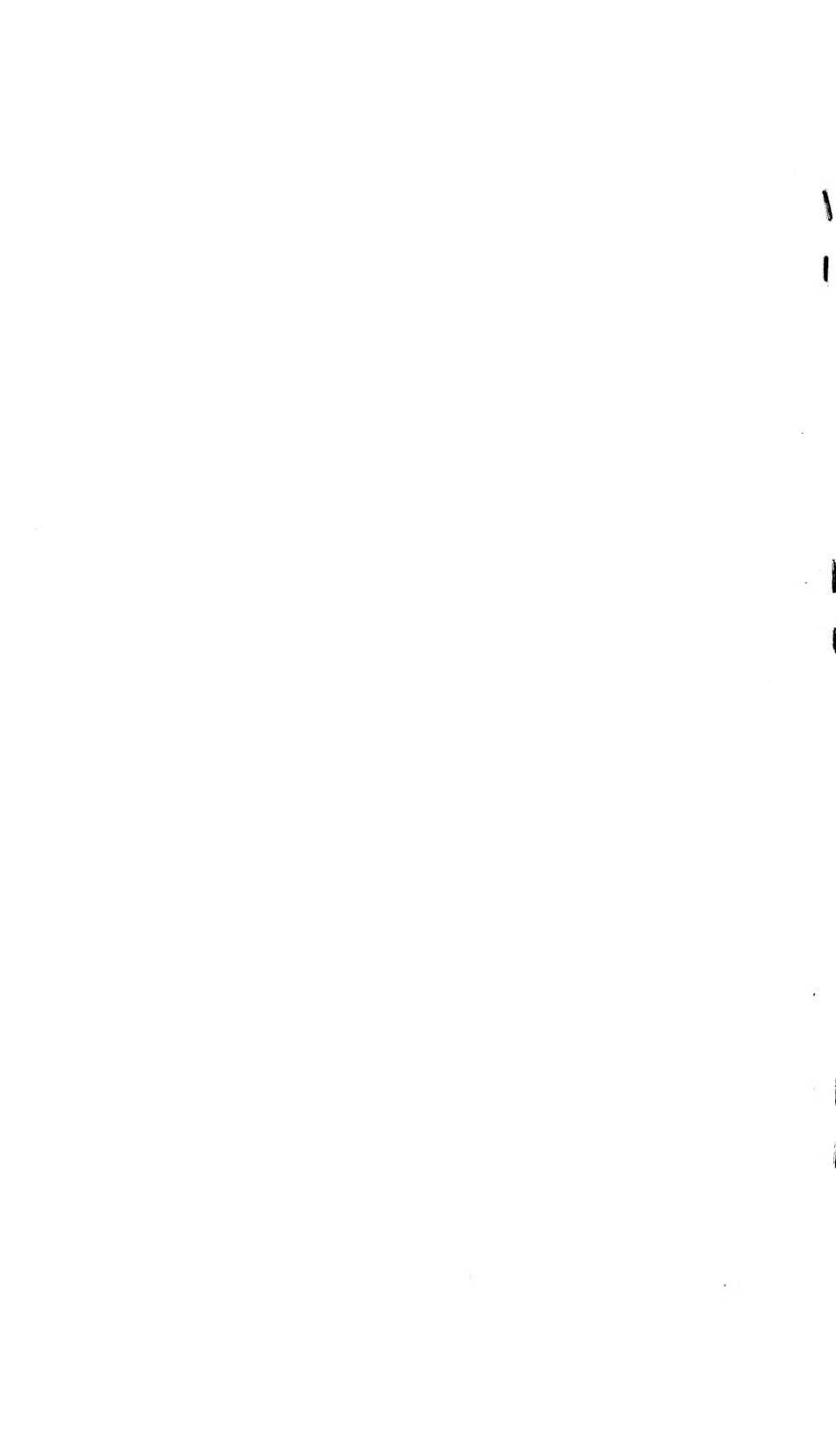

LIBRARY OF CONGRESS



0 014 758 330 8