



This is a digital copy of a book that was preserved for generations on library shelves before it was carefully scanned by Google as part of a project to make the world's books discoverable online.

It has survived long enough for the copyright to expire and the book to enter the public domain. A public domain book is one that was never subject to copyright or whose legal copyright term has expired. Whether a book is in the public domain may vary country to country. Public domain books are our gateways to the past, representing a wealth of history, culture and knowledge that's often difficult to discover.

Marks, notations and other marginalia present in the original volume will appear in this file - a reminder of this book's long journey from the publisher to a library and finally to you.

Usage guidelines

Google is proud to partner with libraries to digitize public domain materials and make them widely accessible. Public domain books belong to the public and we are merely their custodians. Nevertheless, this work is expensive, so in order to keep providing this resource, we have taken steps to prevent abuse by commercial parties, including placing technical restrictions on automated querying.

We also ask that you:

- + *Make non-commercial use of the files* We designed Google Book Search for use by individuals, and we request that you use these files for personal, non-commercial purposes.
- + *Refrain from automated querying* Do not send automated queries of any sort to Google's system: If you are conducting research on machine translation, optical character recognition or other areas where access to a large amount of text is helpful, please contact us. We encourage the use of public domain materials for these purposes and may be able to help.
- + *Maintain attribution* The Google "watermark" you see on each file is essential for informing people about this project and helping them find additional materials through Google Book Search. Please do not remove it.
- + *Keep it legal* Whatever your use, remember that you are responsible for ensuring that what you are doing is legal. Do not assume that just because we believe a book is in the public domain for users in the United States, that the work is also in the public domain for users in other countries. Whether a book is still in copyright varies from country to country, and we can't offer guidance on whether any specific use of any specific book is allowed. Please do not assume that a book's appearance in Google Book Search means it can be used in any manner anywhere in the world. Copyright infringement liability can be quite severe.

About Google Book Search

Google's mission is to organize the world's information and to make it universally accessible and useful. Google Book Search helps readers discover the world's books while helping authors and publishers reach new audiences. You can search through the full text of this book on the web at <http://books.google.com/>

A BATCH OF PYROMETERS.

Journal

Iron and Steel Institute

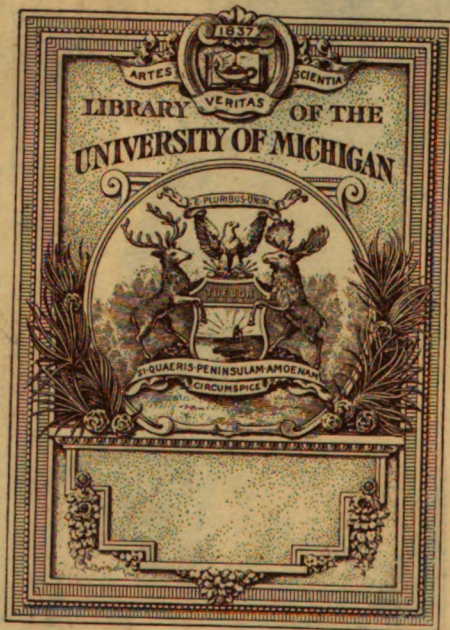

East Engin.
Library
TS
300
.J651;



The Reading-Room of the Iron and Steel Institute.

Frontispiece

THE JOURNAL
OF THE
IRON AND STEEL INSTITUTE

VOL. LXXVI.

EDITED BY
BENNETT H. BROUGE,
SECRETARY



LONDON
E. & F. N. SPON, LIMITED, 57, BAA BARKLET
NEW YORK: SPON & CHAMBERLAIN, 133, E. CHURCH STREET
SOLD ALSO AT THE OFFICES OF THE INSTITUTE
28, VICTORIA STREET, LONDON, S.W.

1908



No. 1

1908

THE JOURNAL

OF THE

IRON AND STEEL INSTITUTE

VOL. LXXVI.

EDITED BY

BENNETT H. BROUGH

SECRETARY



LONDON

E. & F. N. SPON, LIMITED, 57, HAYMARKET

NEW YORK: SPON & CHAMBERLAIN, 123, LIBERTY STREET

SOLD ALSO AT THE OFFICES OF THE INSTITUTE

28, VICTORIA STREET, LONDON, S.W.

1908

Printed by BALLANTYNE, HANSON & Co
At the Ballantyne Press, Edinburgh

PREFACE

THIS volume contains the proceedings of the Annual General Meeting of the Iron and Steel Institute, with the exception of the Carnegie Research Memoirs, which are published in a separate volume, and of the List of Members revised to July 1, 1908, which is published in separate pamphlet form.

The volume also contains a report of the proceedings of the Mining and Metallurgical Congress at Saint Etienne, at which the Institute was officially represented, and an illustrated description of the Institute's new premises.

Obituary notices of deceased members, library reports, and the usual record of progress of the home and foreign iron and steel industries during the first half of 1908, occupy the remaining portion of the volume.

28 VICTORIA STREET, LONDON,
July 1, 1908.

CONTENTS

SECTION I.—MINUTES OF PROCEEDINGS.

	PAGE
Annual General Meeting	1
Election of Members	1
Report of Council	5
Annual Statement of Accounts	16
Votes of Thanks	21
Presentation of Bessemer Medal	23
Carnegie Research Scholarships	26
Middlesbrough Meeting	29
“Improvements in plate rolling-mills.” By Andrew Lamberton, Member of Council	30
Discussion on Mr. Lamberton's paper	39
Correspondence on Mr. Lamberton's paper	49
“A new fatigue test for iron and steel.” By T. E. Stanton	54
Discussion on Dr. Stanton's paper	63
Correspondence on Dr. Stanton's paper	67
“Cast iron in the construction of chemical plant.” By F. J. R. Carulla	71
Discussion on Mr. Carulla's paper	76
Correspondence on Mr. Carulla's paper	80
“The metallurgical and chemical laboratories in the National Physical Laboratory.” By W. Rosenhain	87
Discussion on Mr. Rosenhain's paper	107
Correspondence on Mr. Rosenhain's paper	108
“The pyrometric installation in the gun section, Royal Gun and Carriage Factories, Woolwich.” By J. Wesley Lambert	109
Discussion on Mr. Lambert's paper	132
Correspondence on Mr. Lambert's paper	135
“The utilisation of blast-furnace slag.” By C. de Schwarz	137
Correspondence on Mr. C. de Schwarz's paper	149
“Application of coloured photography to metallography.” By E. F. Law	151
Discussion on Mr. Law's paper	153
Correspondence on Mr. Law's paper	153
“A new type of electric furnace for the smelting of iron.” By B. Igewsky	155
“The physical qualities of steel in relation to its mechanical treatment.” By James E. York	167
Correspondence on “Case-hardening.”	179
The Annual Dinner	183
The new premises of the Iron and Steel Institute	198
“The Mining and Metallurgical Congress at Saint Etienne.” By Bennett H. Brough	203
Obituary	209
Additions to the Library	222

SECTION II.—NOTES ON THE PROGRESS OF THE HOME AND
FOREIGN IRON AND STEEL INDUSTRIES

	PAGE
IRON ORES	230
I. Occurrence and composition	230
Formation of ore deposits	230
Nomenclature of ore deposits	230
Iron ore in Great Britain	230
Iron ore in Austria	231
Iron ore in Bosnia	232
Iron ore in France	232
Iron ore in Germany	232
Iron ore in Greece	232
Iron ore in Italy	232
Iron ore in Norway	232
Iron ore in Russia	233
Iron ore in Spain	233
Iron ore in Sweden	233
Iron ore in Turkey	234
Iron ore in Canada	234
Iron ore in India	235
Iron ore in Western Australia	235
Iron ore in New Zealand	236
Iron ore in Natal	236
Iron ore in British East Africa	236
Iron ore in Nyassaland	237
Iron ore on Lake Superior	237
Iron ore in Minnesota	238
Iron ore in the Adirondack Region	238
Iron ore in Rhode Island	238
Iron ore in Wyoming	238
Iron ore in Cuba	238
Iron ore in Mexico	238
Iron ore in Peru	238
Iron ore in Tunis	238
Iron ore in Togo	239
Manganese ore in Hungary	239
Manganese ore in Russia	239
Manganese ore in Spain	239
Manganese ore in India	239
Manganese ore in Cape Colony	239
Manganese ore in New South Wales	240
Manganese ore in the Portuguese Colonies	240
Ores of the rare metals	240
Tungsten ore	240
Nickel ore in New Caledonia	240
Vanadium ore	241
Magnetite	241
Native iron	241

	PAGE
Native iron-nickel alloy	241
Recent researches on meteorites	241
II. Iron ore mining	242
Deep boring	242
Shaft-sinking	242
Explosives and blasting	242
Compressed air in mines	243
Rock-drills	243
Methods of working	244
Winding	245
Electricity in iron ore mines	245
Mine drainage	245
The lighting of mines	246
Mine surveying	246
Problems in metal-mining	247
Economics of mining	247
Iron ore transport	247
Handling iron ore	247
History of mining	248
III. Mechanical preparation	248
Iron ore dressing	248
Magnetic separators	249
Briquetting iron ore	249
IV. Metallurgical preparation	250
Calcining kilns	250
REFRACTORY MATERIALS	251
Physico-chemical investigation of refractory materials	251
Fireclays	251
Silica sand	251
Manufacture of firebricks	251
Graphite	252
Magnesite	253
Dolomite	254
FUEL	255
I. Calorific value	255
Calorimetry	255
Pyrometry	256
Fuel value of coal	257
Steam-boiler heating	257
Smoke abatement	258
II. Coal	258
Chemistry of coal	258
Coal in the Midlands	259
Coal in Lancashire	259
Coal in Ireland	259
Coal in Austria	260
Coal in Belgium	260
Coal in Bosnia	260

	PAGE
Coal in Germany	260
Coal in Hungary	261
Coal in Italy	261
Coal in Roumania	261
Coal in Russia	261
Coal in India	261
Coal in Canada	262
Coal in Cape Colony	263
Coal in British East Africa	263
Coal in New South Wales	263
Coal in Western Australia	264
Coal in Victoria	264
Coal in New Zealand	264
Coal in the United States	265
Coal in Alabama	265
Coal in Arkansas	265
Coal in California	265
Coal in Colorado	266
Coal in Illinois	266
Coal in Kentucky	266
Coal in Michigan	266
Coal in Montana	266
Coal in New Mexico	267
Coal in Pennsylvania	267
Coal in Utah	267
Coal in Virginia	267
Coal in Wyoming	268
Coal in the Island of Saghalien	268
Coal in Japan	269
Coal in Peru	269
Coal in the Sahara	269
Peat	269
Weathering of coal	270
Sampling coal	270
III. Charcoal	271
Charcoal kilns	271
Charcoal by-products	271
The charcoal industry of Sweden	271
IV. Coke	272
Beehive coke-ovens	272
By-product coke-ovens	273
Coke-oven gases	276
Peat coke	276
V. Liquid fuel	276
Origin of petroleum	276
Petroleum in Scotland	277
Petroleum in Austria	277
Petroleum in Hungary	277
Petroleum in Italy	277
Petroleum in Portugal	278

	PAGE
Petroleum in Roumania	278
Petroleum in Russia	278
Petroleum in Canada	279
Petroleum in Queensland	279
Petroleum in South Africa	279
Petroleum in the West Indies	279
Petroleum in the United States	280
Petroleum in California	281
Petroleum in Ohio	281
Petroleum in Pennsylvania	281
Petroleum in West Virginia	281
Petroleum in Wyoming	281
Petroleum in Peru	282
Petroleum in the Argentine Republic	282
Petroleum in Borneo	282
Petroleum in Corea	282
Petroleum Congress	282
Asphalt	282
Bitumen	283
Oil shale in New South Wales	283
Oil shale in France	283
Boring for petroleum	284
Uses of petroleum	284
VI. Natural gas	284
Natural gas in Hungary	284
Natural gas in Russia	284
Natural gas in Canada	284
Natural gas in the United States	285
Natural gas in Pennsylvania	285
Natural gas in Wyoming	285
VII. Artificial gas	286
Gas-producers	286
Producer-gas for power purposes	286
Water-gas	287
Gas-engines	287
VIII. Coal-mining	289
Underground temperature	289
Search for coal	290
Shaft-sinking	290
Explosives in collieries	291
Coal-wedge	291
Electricity in collieries	291
Compressed air at collieries	292
Coal-cutting machinery	292
Mine supports	292
Methods of working	293
Underground haulage	296
Winding-engines	296
Winding appliances	297
Winding-ropes	298

	PAGE
Pit-head frames	298
Mine drainage	298
Mine ventilation	299
Gases in mines	299
Colliery explosions	299
The lighting of collieries	302
Underground fires	302
Life-saving appliances	303
Subsidence	304
History of coal-mining	304
Economics of mining	304
IX. Coal-screening and washing	305
Coal-screening	305
Coal-washing	305
Coal-handling	306
Briquette manufacture	306
PRODUCTION OF PIG IRON	308
I. Blast-furnace practice	308
Improvements in blast-furnace practice	308
Scaffolding at blast-furnaces	310
The destructive action of graphite on blast-furnace linings	311
Phosphatic chalk for blast-furnace use	312
Zinc in the blast-furnace	312
Clearing tapholes	313
Charging arrangements	313
Works machinery	313
Purifying boiler feed-water	313
Blowing-engines	313
Blast-furnace gases	314
Gas-cleaning	318
The Staveley Ironworks	318
Austrian blast-furnaces	318
German blast-furnaces	319
Hungarian blast-furnaces	319
Italian blast-furnaces	319
Canadian blast-furnaces	319
Indian blast-furnaces	319
American blast-furnaces	319
History of iron	320
II. Chemical composition of pig iron	322
Pig iron analyses	322
Analyses of German pig iron	322
Württemberg pig iron	323
Brazilian pig iron	323
III. Blast-furnace slags	323
Fusibility of lime-alumina-silica mixtures	323
Titaniferous slags	323
Bricks from blast-furnace slags	324
Portland and blast-furnace cement	324

	PAGE
IV. Foundry practice	324
Cupola practice	324
Cupola blowers	325
Foundry appliances	326
Foundry mixtures	326
Chemistry in the foundry	327
Electric furnaces for foundry work	327
Machine-cast and sand-cast pig iron for foundry work	327
Recovery of iron from cupola slag	328
American foundries	328
Chinese and Japanese foundries	328
Moulding sand	328
Green sand moulding	329
Machine moulding	329
Casting iron in metallic moulds	329
Drying ovens	330
Large castings	330
Malleable castings	330
Semi-steel castings	330
Cleaning castings	331
Cast-iron pipes	331
PRODUCTION OF MALLEABLE IRON	332
Direct production of wrought iron	332
Decarburisation of iron	332
Danks puddling furnace	333
Electric smelting of iron	333
Special processes of electric smelting	336
FORGE AND MILL MACHINERY	341
Steam-hammers	341
Forging-presses	341
Electricity in rolling-mills	342
Rolling-mills	344
American rolling-mills	344
Rolling-mill scale	346
Rolling-mill engines	346
PRODUCTION OF STEEL	348
I. The carburisation of malleable iron	348
Crucible steel	348
Crucible tongs	348
History of steel	348
II. The open-hearth process	349
New open-hearth steel plant	349
Steelworks in Austria	350
Open-hearth steelworks in Germany	351
Open-hearth steelworks in Canada	351
Open-hearth steelworks in the United States	352
Steelworks equipment	352

	PAGE
III. The Bessemer process	353
Wills steel converter	353
The Flohr addition to Bessemer basic charges	353
Small Bessemer plant	355
Comparison of Bessemer and open-hearth processes	355
Duplex steel-making process	355
FURTHER TREATMENT OF IRON AND STEEL	357
Case-hardening	357
Annealing furnaces	357
Heat treatment of steel	357
Welding	358
Workshop treatment of steel	361
Steel castings	361
High-speed steel	361
Steelworks equipment	361
Iron alloys used in the steel industry	362
Steel rails	365
Sleepers	365
Steel for motor-cars	366
Steel for structural purposes	368
Reinforced concrete	369
Armour-plates and projectiles	370
Armour-plate vault	371
Ordnance	371
Tinning	372
Electrolytic pickling of steel	372
Duplex metal	372
Needles	372
Spanish ironwork	372
PHYSICAL PROPERTIES	374
Specific heat of iron	374
Hardness of steel	376
Segregation of steel ingots	377
Influences of gases on the structure of cast iron and steel	378
Crystallisation of steel	378
The cohesion of steel	379
Structure of malleable iron	379
Microstructure of iron and steel	379
Metallography	380
Solidification points and transformation in alloys	381
Magnetic properties of iron and steel	383
Recalescence curves	384
Permanent deformation of metals	385
Physical properties of cast iron	385
Theory of case-hardening	386
Bending tests	386
Impact testing	386
Testing hardened steel	387
Constituents of hardened steel	388

	PAGE
Tests of hollow cylinders	388
Formation of cracks in plates	388
Load for railway bridges	389
The causes of damages to gas-pipes by the electric current	389
Bursting-point of flanged fittings	390
The action of toothless circular saws	390
Strength of chain-links	391
Steel rails	391
Corrugation of tramway rails	392
Nickel in cast iron	393
Iron-tungsten alloys	393
Iron-chromium alloys	393
Ferro-titanium	394
Testing-machines	395
Elastic properties of steel	395
Reinforced concrete	396
Specifications	397
The National Physical Laboratory	397
Standard notation	397
CHEMICAL PROPERTIES	399
Passivity of iron	399
Ocluded gases in steel	399
Direct union of carbon and hydrogen at high temperatures	404
Colour of ferric oxide	404
Iron salts	404
Ferro-silicon	404
Diamond and carborundum crystals in steel	404
Composition of slag in cast steel	405
Theory of equilibrium in the iron-carbon system	405
Solubility of graphite in iron	406
Graphite and graphitic carbon in pig iron	407
Influence of phosphorus on iron-carbon alloys	408
Manganese-iron alloys	409
Iron-molybdenum alloys	409
Copper-iron alloys	409
Iron-aluminium alloys	409
Tantalum steel	409
The rusting of iron	409
Corrosion of iron and steel	410
Precipitation of iron from pyrites	411
Impure nickel plate	411
The early metallurgy of tungsten	411
CHEMICAL ANALYSIS	412
I. Analysis of iron and steel	412
Ironworks analysis	412
Determination of carbon	412
Determination of manganese	412
Determination of phosphorus	413

	PAGE
Some sources of error in the determination of phosphorus	413
Determination of chromium	414
Determination of tungsten	414
Determination of nickel	414
Determination of titanium	415
Determination of nitrogen in iron	415
II. Analysis of iron ores and slag	416
Determination of iron	416
Determination of phosphoric acid	416
Determination of silica	416
Determination of magnesia	417
III. Analysis of fuel	417
Coal analysis	417
Determination of moisture	418
Determination of volatile matter	418
Petroleum analysis	418
IV. Analysis of gas	418
Apparatus for gas analysis	418
Methods of gas analysis	419
Automatic gas analysis	419
STATISTICS	421
I. United Kingdom	421
Mineral statistics	421
Iron trade statistics	421
Iron ore	422
Accidents in mines and quarries	423
Shipbuilding	423
Exhibitions	423
II. Australasia	423
Ironmaking in New South Wales	423
Mineral statistics of New Zealand	424
Mineral statistics of South Australia	424
III. Austria-Hungary	424
Mineral statistics of Austria	424
Mineral statistics of Hungary	424
IV. Belgium	425
Mineral statistics	425
Iron trade statistics	425
V. Bulgaria	425
Mining law	425
VI. Canada	425
Mineral statistics	425
Iron trade statistics	426
VII. China	426
Mineral statistics	426
Iron industry	427

CONTENTS.

XV

	PAGE
VIII. France	429
Mineral statistics	429
Iron trade statistics	430
IX. Germany	431
Mineral statistics	431
Iron trade statistics	432
Mineral statistics of Prussia	432
Mineral production of Saxony	433
Metallurgical education	433
The German Museum at Munich	433
Bavarian workmen's museum	433
Provident funds	434
X. Greece	434
Mineral statistics	434
XI. India	434
Mineral statistics	434
Iron ore in Mysore	434
XII. Japan	435
Mineral statistics	435
XIII. Natal :	435
Mineral statistics	435
XIV. Norway	435
Mineral statistics	435
XV. Orange River Colony	436
Mineral statistics	436
XVI. Roumania	436
Mineral statistics	436
XVII. Russia	436
Iron trade statistics	436
Mineral production of the Caucasus	436
XVIII. Servia	437
Mineral statistics	437
XIX. Spain	437
Iron trade statistics	437
XX. Sweden	438
Mineral statistics	438
Iron trade statistics	438
XXI. Transvaal Colony	439
Mineral statistics	439
Iron and steel	439
XXII. Turkey	439
Asphalt mining	439
XXIII. United States	439
Mineral statistics	439
Iron trade statistics	440

	PAGE
Iron ore	442
Coal	443
Coke	444
Petroleum	444
Graphite	444
Jamestown Exhibition	444
XXIV. Comparative tables	444
The world's production of coal and iron	444
The world's production of iron ore	446
Comparative mineral statistics	447
BIBLIOGRAPHY	448
Metallurgy	448
Mining	453
INDEX	457

LIST OF PLATES.

Frontispiece. THE READING-ROOM OF THE IRON AND STEEL INSTITUTE.

I. Drawings illustrating Mr. Lamberton's paper	32
II. to IV. Photographs illustrating Mr. Rosenhain's paper	96
V. Diagram illustrating Mr. Rosenhain's paper	96
VI. Diagram illustrating Mr. Lambert's paper	128
VII. to VIII. Photographs of the Institute's new premises	200

CORRIGENDA

- Vol. lxxiii. p. 295, line 9, for '0·21' read '0·25.'
 Vol. lxxiv. p. 5, line 13, for 'Fig. 3' read 'Fig. 2.'
 Vol. lxxv. p. 114, line 16 from bottom, for 'scintella' read 'scintilla.'
 Vol. lxxv. p. 506, last line, for 'vol. cxliii.' read 'cxliv.'

THE IRON AND STEEL INSTITUTE.

SECTION I.

MINUTES OF PROCEEDINGS.

ANNUAL GENERAL MEETING.

THE ANNUAL GENERAL MEETING of the IRON AND STEEL INSTITUTE was held at the Institution of Civil Engineers, Great George Street, Westminster, on Thursday, May 14, 1908—Sir HUGH BELL, Bart., President, in the chair.

The SECRETARY read the minutes of the previous meeting held in Vienna, on September 23 and 24, 1907, which were found to be a correct record, and signed.

Mr. ARTHUR HORSFIELD (Wakefield) and Mr. SEPTIMUS YOUNG (London) were appointed as scrutineers, and on the completion of the scrutiny reported that the following candidates had been duly elected as members of the Institute:—

NAME.	ADDRESS.	PROPOSERS.
Ahles, Robert L. . .	Williamsport, Pennsylvania, U.S.A.	John S. Kennedy, Leonard Peckitt, B. F. Fackenthal, jun.
Allison, Archibald . .	204 Ecclesall Road, Sheffield	W. B. Hamilton, J. O. Arnold, A. S. Pye-Smith
Bladen, Thomas . . .	Barrow Hill, Chesterfield	Charles Markham, C. J. Stoddart, F. W. Dick.
Boecker, Martin . . .	Friedenshütte, bei Station Morgenroth, Silesia	Sir Hugh Bell, F. Schuster, J. Goujon.
Böhler, Richard Friedrich	Columbia University, New York, U.S.A.	H. M. Howe, Bradley Stoughton, Geo. W. Maynard.

ELECTION OF MEMBERS.

NAME.	ADDRESS.	PROPOSERS.
Brearley, Arthur William Christen, Oscar . . .	Salamander Works, Riga, Russia Witkowitz Bergbau und Eisenhütten Gewerkschaft, Wit- kowitz, Austria	Harry Brearley, F. C. Moor- wood, W. H. Dyson. T. E. Vickers, Cosmo Johns, Alleyne Reynolds.
Clift, Arthur Stebbins	York Mansions, York Street, Westminster, London, S.W.	Alex. Siemens, J. Angus, Sir Alex. B. W. Kennedy.
Colloseus, Heinz . .	15 Spicherstrasse, Ber- lin, Germany	C. Ritter von Schwarz, Baron von Jüptner, A. Sonnenschein.
Cowell, Richard Ernest	Royal Exchange, Middlesbrough	Arthur W. Richards, Walter S. Hill, Jos. Harrison.
Cross, William, Assoc. R.S.M.	46 Lincoln's Inn Fields, London, W.C.	Sir W. Lloyd Wise, Bedford McNeill, R. A. Hadfield.
Dalton, Archibald Cecil	Trent Iron Works, Scunthorpe, near Doncaster	W. H. Ellis, J. O. Arnold, A. McWilliam.
Davies, William Robert	Forest Lyn, Heoldon, Whitechurch, Glam.	H. S. Thomas, John R. Davies, H. Fernihough.
Deutsch, <i>Kommerzien-</i> <i>rat</i> Felix	2 Friedrich Carl Ufer, Berlin, Germany	Sir Hugh Bell, W. H. Bleckly, D. Selby-Bigge.
Dixon, Cuthbert. . .	Springrove, Oughti- bridge, Sheffield	R. A. Hadfield, W. F. Beard- shaw, W. W. Wood, jun.
Dorman, Arthur. . .	Grey Towers, Nun- thorpe, S.O., Yorks.	Sir Hugh Bell, Arthur Cooper, J. E. Stead.
Durrans, Paul . . .	Penistone, near Shef- field	George Hoyland, B. G. Wood, W. W. Wood, jun.
Field, George Kenelm	c/o Colonel R. E. B. Crompton, C.B., Thriplands, South Kensington, London, S.W.	Richard Sharp, Harry Bent- ley, Cecil Walton.
Fraser, William . . .	Lochrin Iron Works, Coatbridge, N.B.	James Kerr, James Hamil- ton, C. F. MacLaren.
Garson, Stanley Treavor	Ormesby Iron Works, Middlesbrough	F. H. Marshall, T. Greville Jones, C. H. Ridsdale.
Gloz, Adolf, Ph.D. . .	Bad Harzburg, Ger- many	C. Ritter von Schwarz, Baron von Juptner, A. Sonnenschein.
Graham, Robert. . .	The Ebbw Vale Steel, Coal and Iron Co., Ltd., Ebbw Vale, Mon.	Fred Mills, E. P. Martin, William Evans.
Gridley, Arnold Babb	Hinton's Buildings, Middlesbrough	Sir Hugh Bell, Charles Dorman, Maurice L. Bell.
Harriman, Norman F., B.Sc.	Union Pacific Labora- tory, Omaha, Neb., U.S.A.	C. B. Dudley, W. R. Web- ster, H. V. Wille.
Harrison, John William	Vicarage Street, Iron Works, Wakefield	W. H. Rhodes, P. S. Cra- dock, H. Marsden.
Henriques, <i>Lieut.-Col.</i> Cecil Quixano, R.E., M. Inst. C.E., M. I. Mech. E.	15 Victoria Street, Lon- don, S.W.	A. Tannett-Walker, E. Windsor Richards, E. P. Martin.

NAME	ADDRESS	PROPOSERS
Herwegh, Camille .	Pompey, Meurthe-et-Moselle, France	E. Poulaine, G. Forster Martin, W. O. Scrivener
Horne, James William, B.Sc.	Kilgraston, Bexley Road, Erith, Kent	J. S. Balfour, S. L. Dore, Cyrus Braby.
Hunter, David . . .	7 Reginald Terrace, Leeds	Benjamin Talbot, Walter Crooke, jun., James Riley.
Johnson, Philip Heber, Assoc. M. Inst. C.E.	Engineer's Office, Mid- land Railway, Derby	Wm. Richards, Joseph Jackman, J. J. Pickford.
King, Ernest Gerald .	33 Bedford Street, Strand, London, W.C.	W. H. Butlin, James Duf- field, J. E. Swanker.
Lantsberry, Fred. C. A. H., B.Sc.	Highfield, Stanley Road, Teddington, Middlesex	Walter Rosenhain, Alex. E. Tucker, A. McWilliam.
Law, Edward Fulton, Assoc. R.S.M.	28 Victoria Street, London, S.W.	F. W. Harbord, J. E. Stead, Sir Hugh Bell.
Lemmy, George Kings- ford	35 and 36 Bedford Street, Strand, Lon- don, W.C.	W. H. Maw, A. T. Hollings- worth, Clarence Bird.
Lentz, Arthur . . .	Rath, near Düsseldorf, Germany	E. Schrödter, Hugo Sack, Heinrich Lueg.
Le Tall, Sydney Harold	22 Springfield Road, Millhouses, Sheffield	Herbert Hughes, Sydney J. Robinson, J. Stanley Watson.
Lunt, Reginald Lacy .	112 Northgate, Wake- field	John Little, Walter Crooke, jun., G. Cradock.
Meunier, L.	Acèdries de Longwy, Mont St. Martin, Meurthe-et-Moselle, France.	A. Dreux, P. Chamfrault, L. Pasquier.
Monypenny, John Henry Gill	73 Langsett Road, Shef- field	W. J. Armitage, J. O. Arnold, A. McWilliam.
Mosscrop, Alfred Mitton	Studley House, Lin- thorpe, Middles- brough	Sir Hugh Bell, W. L. John- son, Maurice L. Bell.
Mowbray, Archibald John Holme, B.A., Assoc. M. I. Mech. E.	Sutherland House, Stir- ling	W. H. Luther, Z. W. Onions, Herbert Beard.
Nani, Elconide . . .	7 Rue Amilcar, Tunis	H. M. Jenks, A. Tannett- Walker, E. T. Agius.
Needham, Joseph George	44 Brown Street, Man- chester	Sir Alfred Hickman, W. Hutchison, C. T. Need- ham.
Neuman, Viktor von .	Markt, near Lilienfeld, Austria	Hugo von Noot, H. Bührlen, W. Kestranek.
Nisser, Carl Martin .	Stjarnsund, Sweden	J. A. Brinell, J. A. Don- caster, P. Bergendal.
Nomura, Major I. . .	c/o Takata & Co., 88 Bishopgate Street Within, London, E.C.	S. J. Robinson, W. H. Thomas, J. H. Fisher.
Parker, Sidney S. . .	River Don Works, Sheffield	Cosmo Johns, J. E. Stead, R. A. Hadfield.
Peat, James Barclay, Assoc. M. Inst. C.E.	27 Granville Terrace, Redcar	Benjamin Talbot, T. Twy- nam, Tom Westgarth.
Ponti, Alberto delli .	Pozzuoli Steel Works, Pozzuoli, Italy	James Jackson, J. Rossiter Hoyle, Frederick Best.

ELECTION OF MEMBERS.

NAME.	ADDRESS.	PROPOSERS.
Pratt, Dudley H. . .	Grovesend Steel Works, Gorseinon, South Wales	W. Gowland, W. H. Merrett, E. A. Wraight.
Primrose, John Stewart Glen	6 Mount Stuart Street, Glasgow	W. Rosenhain, Prof. Thomas Turner, J. E. Stead.
Putnam, Arthur. . .	Darlington Forge Co., Ltd., Darlington	Geo. Ainsworth, T. Putnam, E. J. Smith.
Rider, James, jun. . .	Windsor Road, Salt- burn-by-the-Sea	J. E. Stead, Illyd Williams, J. P. Bedson.
Ridge, Harry Mac- kenzie	Owton Manor, Seaton Carew, Co. Durham	J. H. Moysey, A. W. Richards, E. Crowe.
Schöngut, Joseph . .	7 Brückengasse, Mahr, Oustrau, Austria	O. Goldstein, F. Reitlinger, A. Weiskopf.
Shaw-Scott, Gilbert, M.Sc.	Streetly Wood, Sutton Coldfield	Prof. Thomas Turner, W. Gowland, F. F. Simpson.
Simmons, Charles . .	127 Rustlings Road, Sheffield	A. Firth, T. H. Firth, John Little.
Smith, George Edward	Steam and Electric Crane Works, Rodley, near Leeds	Geo. Craddock, H. Marsden, W. W. Sagar.
Steck, Ernst Hugo . .	21 Mittelstrasse, Berlin, N.W., Germany	Frederick Siemens, Alfred Harvey, Prof. Thomas Turner.
Stewart, John . . .	Butterley Iron Works, Derby	Andrew Lamberton, Thos. Davie, J. S. Trinham.
Storey, John Edward .	Larkfield, Lower Walton, Warrington	F. W. Monks, R. V. Wheeler, H. Owen.
Stottner, Jacob, M.I.E.E.	121/125 Charing Cross, Road, London, W.C.	Arthur W. Richards, J. C. Jones, R. C. V. Whitfield.
Szarvasy, Frederic Alexander	19 Weymouth Street, Portland Place, London, W.	Sir Hugh Bell, J. E. Stead, R. A. Hadfield.
Taylor, Knox, M.Amer. I.M.E.	The Taylor Iron and Steel Co., High Bridge, New Jersey, U.S.A.	R. A. Hadfield, A. G. M. Jack, Sir Hugh Bell.
Thornley, Thomas William	Railway Parade, Lith- gow, N.S.W., Aus- tralia	Jos. H. Harrison, R. How- son, Penry Williams.
Toombs, William . .	33 Brazenose Street, Manchester	Myles Cooper, Jos. Adam- son, H. Adamson.
Tyzack, Frederick . .	Messrs. Tyzack, Sons & Turner, Ltd., Little London Works, Sheffield.	B. G. Wood, S. E. Skelton, W. W. Wood, jun.
Wedekind, Werner Claude	Fanners, Wicham, Bishops, Essex	H. Wedekind, W. R. Hay, Clarence Bird.
Whigham, Harry Thomas	71 King William Street, London, E.C.	R. A. Hadfield, A. G. M. Jack, I. B. Milne.
White, James . . .	Bonlea Foundry, Thornaby-on-Tees	Sir Hugh Bell, William Whitwell, C. A. Head.

The SECRETARY then read the following report of Council upon the proceedings of the Institute during the year 1907.

REPORT OF COUNCIL.

At this, the thirty-ninth Annual General Meeting of the Iron and Steel Institute, the Council present to the members their Report on the Proceedings of the Institute during the year 1907, and are glad to note that the year has been one of activity and progress.

THE ROLL OF THE INSTITUTE.

During the year 1907 his Imperial and Royal Highness the Archduke Frederick of Austria was elected an Honorary Member, and there have been added to the register one hundred and sixteen names. The number of members on the roll of the Institute on December 31, 1907, was:—

Patron	1
Honorary Members	12
Life Members	46
Ordinary Members	2041
Total	<u>2100</u>

The growth of the Institute since its inauguration is shown by the following statistics:—

	1869	1877	1887	1897	1907
Patron	1
Honorary Members	6	12
Life Members	6	46
Ordinary Members	287	900	1313	1488	2041
Totals	287	900	1313	1500	2100

The Council have to congratulate several members of the Institute who have had high distinctions conferred upon them. Sir Hugh Bell, Bart., President, was appointed a member of the Board of Trade Advisory Committee on the Census of Production Act, and has been re-elected Chairman of the Tees Conservancy; the Rt. Hon. Sir James Kitson, Bart., Past-President, on June 28 was

created a Peer of the United Kingdom (Lord Airedale of Gledhow); Mr. A. Carnegie, Past-President, has received the Grand Cross of the Legion of Honour and of the Orange-Nassau Order; Sir W. T. Lewis, Bart., Vice-President, has been created a Knight Commander of the Royal Victorian Order and a Knight of Grace of the Order of the Hospital of St. John of Jerusalem; Mr. W. Beardmore, Vice-President, has received the Japanese decoration of the Order of the Rising Sun; Mr. A. Greiner, Member of Council, has been created a Commander of the Order of St. Olaf of Norway, and has been elected President of the Belgian Society of Engineers; Mr. G. Ainsworth, Member of Council, was appointed a member of the Departmental Committee on Check-weighing; Mr. G. Canet, Honorary Member, has received the decoration of the Order of the Double Dragon of China; Dr. R. W. Raymond, Honorary Member, has been elected an honorary member of the Canadian Mining Institute; Dr. H. Wedding (Bessemer Gold Medallist), Honorary Member, has received the decorations of the Order of the Red Eagle, second class, with oak wreath, and of the Royal Bavarian Order of St. Michael; Mr. Joseph Adamson has been elected President of the Manchester Association of Engineers; Mr. J. A. F. Aspinall has received the honorary degree of Master of Engineering (Liverpool University); Mr. Fritz Baare has received the title of Geheimer Kommerzienrat; Mr. H. H. Bedford has been elected Master Cutler of Sheffield; Mr. G. T. Beilby has been appointed President of the West of Scotland Technical College; Mr. G. G. Blackwell has had conferred upon him by the King of Greece the Cross of Officer of the Order of the Redeemer; Mr. J. A. Brinell (Bessemer Gold Medallist) has received the honorary degree of Doctor of Science (Upsala University); Mr. W. J. Crossley, M.P., has been appointed a member of the Departmental Committee on the National Physical Laboratory; the Duke of Devonshire was appointed Chancellor of the University of Manchester; Mr. Herbert Eccles was appointed a member of the Departmental Committee on Check-weighing; Mr. E. Ehrensberger has received the honorary degree of Doctor of Engineering (Munich); Mr. K. Engel has received the French Gold Medal "récompense pour belles actions," in recognition of his services in leading the German rescue corps at the Courrières Colliery; Mr. G. Gillhausen has received the honorary degree of Doctor of Engineering (Aachen); General C. F. Hadden has been appointed Master-General of the Ordnance; Sir A. B. W. Kennedy has received the honorary degree of Doctor of

Engineering (Liverpool University); Mr. W. P. Kirkpatrick has been created a Knight of the Order of Leopold; Professor H. Le Chatelier has been elected a member of the French Academy of Sciences in succession to Moissan; Admiral A. Lindman has been appointed Prime Minister of Sweden; Mr. J. T. Milton has been awarded the Watt Gold Medal of the Institution of Civil Engineers; Dr. Ludwig Mond has received the honorary degree of Doctor of Science (Oxford University); Dr. T. Peters has received the Cross of the Bavarian Order of St. Michael; Professor H. Ponthière has been created an Officer of the Order of Leopold; Mr. T. Hurry Riches has been elected President of the Institution of Mechanical Engineers; Mr. A. Serena has been created a Commander of the Order of St. Maurice and St. Lazarus; Colonel T. E. Vickers, C.B., has received the Japanese decoration of the Order of the Rising Sun, and has been awarded by the Institution of Civil Engineers the Howard Quinquennial Prize; Dr. F. Wüst has received the title of Geheimer Regierungsrat; and Mr. B. H. Brough, Secretary, has been elected an honorary member of the Canadian Mining Institute.

During the year 1907 the Institute suffered heavy losses by the death of well-known members, amongst whom were several active contributors to its work. The list comprises the following thirty-four names:—

His Majesty Oscar II., King of Sweden (honorary member)	December 8.
Anderson, A. O. (Sweden)	February.
Baker, Sir Benjamin, K.C.B. (London)	May 19.
Bond, Edwin (Birmingham)	May 8.
Cleghorn, J. (London)	September 24.
Clements, O. P. (Birmingham)	January.
Darrow, C. R. (Newcastle, Pa.)	April.
Davies, W. H. (Stoke-on-Trent)	January 21.
Dunell, G. R. (London)	May 12.
Fearneough, W. (Sheffield)	December 31.
Haggie, P. S. (Gateshead-on-Tyne)	June 22.
Harrison, George (Woolwich)	December 21.
Hart, John (Middlesbrough)	December 3.
Hartley, J. (Sheffield)	October 19.
Jacks, William, LL.D. (Glasgow)	August 9.
Koehler, H. (Bochum, Westphalia)	January 11.

Lees, J. Bayley (Handsworth)	August 17.
Lees, Samuel (Ashton-under-Lyne)	October 5.
Leveson-Gower, The Hon. E. F. (London)	May 30.
Lundvik, C. (Sweden)	—
Magery, Jules (Namur, Belgium)	January 15.
Millward, G. A. (Birmingham)	July 21.
Nurse, P. F. (London)	June 20.
Palmer, Sir C. M., Bart., M.P. (Newcastle-on-Tyne)	June 4.
Pearce, Sir W. G. (London)	November 2.
Post van der Burg, Hendrik (Rotterdam)	December 31.
Richards, W. H. (Darlaston)	January.
Russell, Emil (Berlin)	October 22.
Stephens, D. (Kidwelly)	October 19.
Storey, T. W. P. (Mostyn)	March 15.
Summerson, S. J. (Darlington)	November 7.
Willard, E. B., jun. (Wellston, Ohio)	May 21.
Wilson, Sir Alexander, Bart. (Sheffield)	April 27.

The following death occurred in 1906, but was not noted in the Council Report for that year :

Simpson, R. (Whitehaven) Dec. 20, 1906.

The King of Sweden, honorary member, honoured the Institute by attending the business meeting of the Institute, and by extending generous hospitality to members on the occasion of the Stockholm Meeting in 1898, and evinced much interest in the work of the Institute. The Institute was represented at the funeral in Stockholm by Director-General R. Åkerman, honorary member, and sent a wreath as a tribute of reverence and gratitude. Subsequently a card signed by H.M. the Dowager-Queen of Sweden was received through the Swedish Legation in London, thanking the Institute for the homage rendered to the memory of the late King Oscar II.

Of the deceased members, Sir Benjamin Baker, Bart., in 1885 contributed a paper on the Forth Bridge to the Proceedings. Sir Charles Mark Palmer, Bart., was an original member of the Institute, and read a paper at the first Annual General Meeting in London in 1870. Sir Alexander Wilson, Bart., was also an original member of the Institute, the members of which were hospitably entertained by him on the occasion of the meeting in Sheffield in 1905. Mr. G. R. Dunell, Dr. William Jacks, and Mr. Jules Magery were warm supporters of the Institute, and regular in their attendance at

its meetings, while Mr. P. F. Nursey was similarly closely associated with its work for many years.

Particulars of the careers of the deceased members will be found in the obituary notices published in the Journal of the Institute.

In consequence of non-payment of subscriptions the names of thirteen members have been removed from the list, and there have been twenty-nine resignations of membership.

FINANCE.

The financial prosperity of the Institute is a matter for congratulation. The Statement of Accounts for the year 1907, verified by the Auditors, is now submitted to the members by the Hon. Treasurer. It will be observed that the receipts for the year amounted to £6454, and the expenditure to £5536.

The corresponding figures for recent years were as follows:—

	Receipts.			Expenditure.		
	£	s.	d.	£	s.	d.
1906 . . .	6610	4	3	5915	11	8
1905 . . .	6271	11	10	5257	8	2
1904 . . .	5666	14	10	5727	12	11
1903 . . .	5424	8	10	5205	6	0

MEETINGS.

During the year under review two meetings were held as usual. The Annual Meeting on May 9th and 10th was held at the Institution of Civil Engineers, and the constant courtesy of that distinguished body in affording accommodation demands grateful acknowledgment.

The Autumn Meeting, held, after an interval of twenty-five years, for the second time, in Vienna was very largely attended and brilliantly successful. An exceedingly influential Reception Committee was formed, and the warm welcome which was accorded the members and the excellent arrangements made for their comfort and entertainment were highly appreciated. The members were honoured by a reception at Court; and generous hospitality was dispensed by the Reception Committee, the civic authorities, and the owners of the leading works. The excursions in connection with the meeting were most interesting and instructive, and have been described at length in the Journal of the Institute.

To Dr. Eugen Herz, who with Mr. Hugo von Noot, jun., acted as honorary secretary of the Reception Committee, and by his ability and indefatigable energy contributed so greatly to the success of the

meeting, the Council have, on behalf of the members, expressed their sense of indebtedness by the presentation of a pearl breast-pin and set of studs; while the valuable services of his colleague, Mr. Hugo von Noot, jun., have been similarly recognised by the presentation of a gold cigarette-case set with rubies. Illuminated addresses of thanks were forwarded to the four Ironworks Companies that had entertained the members, to the Austrian Society of Engineers and Architects, and to the Scientific Club of Vienna. Specially-bound volumes of the Journal containing the Report of the Meeting have been presented to Mr. W. Kestranek, the chairman; Ritter Max von Guttman, vice-chairman; to the other members of the executive committee, as well as to Dr. Neumeyer, the Deputy Burgomaster; and to his Imperial and Royal Highness the Archduke Frederick of Austria, who took so warm an interest in the meeting, and honoured the Institute by allowing his name to be added to the roll of honorary members. The travelling arrangements for the meeting were ably carried out by the Tourist Agency of the Great Northern Railway, and the success of the meeting was enhanced by the assistance rendered by the Austrian State Railways, by the Austrian Bureau of Travel, and by the civic authorities at Prague, Innsbrück, and Salzburg.

The annual dinner of the members of the Institute was held at the Hotel Cecil on May 10. The chair was occupied by the President, and the principal speakers were their Excellencies the Austrian-Hungarian Ambassador, and the Swedish Minister; the Right Hon. Lord-Justice Fletcher Moulton; Admiral Sir Cyprian Bridge, G.C.B.; Colonel Sir Howard Vincent, K.C.M.G., C.B., A.D.C., M.P.; the Rt. Hon. Sir James Kitson, Bart., M.P. (Lord Airedale of Gledhow), Past-President; Mr. Yves Guyot; and Mr. Robert Hammond.

The Institute was also entertained at dinner at the Hall of the Musical Society, Vienna, by the Austrian Reception Committee. The chair was occupied by the President, and the company numbered 600 including ladies. Members of the Austrian Government, of the Vienna City Council, and representatives of learned and scientific associations in Vienna attended, and the principal speakers were his Excellency Baron von Bienert, Minister of the Interior; Dr. Neumeyer, the Deputy Mayor of Vienna; Mr. Kestranek, Chairman of the Reception Committee; the President; and Mr. A. Greiner.

In addition to Sir Hugh Bell's Presidential Address, twenty-one papers were contributed to the Institute's Proceedings during the year. The titles were as follows:—

1. "On the Case-hardening of Mild Steel." By C. O. BANNISTER (London) and W. J. LAMBERT (Woolwich).
2. "On the Erzberg of Eisenerz." By Professor H. BAUERMAN, Honorary Member.
3. "On Steel and Meteoric Iron." By Professor F. Berwerth (Vienna).
4. "On the Use of Steam in Gas Producer Practice." By Professor W. A. BONE (Leeds) and R. V. WHEELER (Warrington).
5. "On Sentinel Pyrometers and their Application to the Heat Treatment of Tool Steel." By H. BREARLEY (Riga, Russia) and F. C. MOORWOOD (Sheffield).
6. "On Induced Draught with Hot-air Economisers for Steelworks and Blast-Furnace Boilers." By A. J. CAPRON (Sheffield).
7. "On a New Blue-Black Paint as a Protective Covering." By F. J. R. CARULLA (Derby).
8. "On the Hardening of Steel." By L. DEMOZAY (Unieux, France).
9. "On the Total Quantity of Blast-Furnace Gas for a given make and its Calorific Value." By Professor J. VON EHRENWERTH, Honorary Member.
10. "On the Relation between the Process of Manufacture and some of the Properties of Steel." By F. W. HARBORD (London).
11. "On the Distribution of Sulphur in Metal Ingot Moulds." By J. HENDERSON (Thornaby Ironworks, Stockton-on-Tees).
12. "On the Application of the Laws of Physical Chemistry in the Metallurgy of Iron." By Baron H. VON JÜPTNER (Vienna).
13. "On the Austrian Iron Industry during the last Twenty-five Years." By W. KESTRANEK (Vienna).
14. "On Hardened Steels." By P. LONGMUIR (Sheffield).
15. "On the Manufacture of Steel from High-Silicon Phosphoric Pig Iron by the Basic Bessemer Process." By A. W. RICHARDS (Grangetown).
16. "On a Method of Producing High-Class Steel from a Pig Iron containing Chromium, Nickel, and Cobalt." By A. W. RICHARDS (Grangetown).
17. "On the Development of Electricity in the Iron and Steel Industries." By D. SELBY BIGGE (Newcastle-upon-Tyne).
18. "On Case-hardening." By G. SHAW SCOTT (Sutton Coldfield).
19. "On the Ageing of Mild Steel." By C. E. STROMEYER (Manchester).
20. "On the Ageing of Mild Steel." (Further Notes.) By C. E. STROMEYER (Manchester).
21. "On Carbon-Tungsten Steels." By T. SWINDEN (Sheffield University).

There was also printed in the Journal a Report on the Nomenclature of Iron and Steel, by a Committee of the International Association for Testing Materials, and correspondence thereon by members of the Institute, and a description by Mr. E. Bian, of the Bian Gas Cleaner.

In order to give improved facilities for discussing the papers brought before the Institute it was decided that papers should be read in abstract, and that speakers in discussion should be limited to five or ten minutes, the manuscript of lengthier contributions being handed in for publication in the Journal.

LIBRARY AND OFFICES.

Numerous presentations to the Library have been made, a list of which is given in the Journal of the Institute. Amongst these are a copy of the third edition of Harbord's *Steel*, presented by Mr. W. H. Bleckly, Hon. Treasurer; a set of early volumes of the Swedish *Jernkontorets Annaler*, presented by Mr. John Crum; and the minute-book of the early meetings relating to the formation of the Iron and Steel Institute, presented by Mr. J. R. Winpenny. Members who have published works valuable for reference, or pamphlets on subjects relating to iron and steel, of which they could present copies, are reminded that such contributions to the Library are highly acceptable for permanent preservation. While chiefly used for editorial purposes in connection with the Institute Journal and for compiling information in response to inquiries addressed by members and others to the Secretary, the Library continues to be consulted from time to time by the members, and the question of improving the accommodation available is receiving the careful consideration of the Council.

To the collection of portraits of Presidents and Bessemer Medallists no additions have been made during the year. Messrs. Maull & Fox have presented a number of platinotype portraits of members of the Institute. Members are invited to favour Messrs. Maull & Fox with a sitting, or to present copies of their photographs in cabinet size for the Institute album.

The office correspondence was slightly less than in 1906. Disregarding circulars and printed matter, the number of letters received and answered during the year was 7960.

PUBLICATIONS.

In place of the usual two volumes, three cloth-bound volumes of the Journal of the Institute have been published, containing, together with the List of Members, 1683 pages of letterpress, 114 plates, and numerous illustrations in the text. The five Carnegie research memoirs were published in a separate volume. In addition to the papers read before the Institute, and the discussions and correspondence relating to them, these volumes contain abstracts of 2737 papers relating to iron and steel and kindred subjects published in other home and foreign journals and transactions during 1907. In the compilation of these abstracts 432 periodical publications, written in twelve languages and published in twenty-seven countries, were systematically

searched; the aim being to provide members with as complete an index as possible to the current literature of iron and steel. Owing to the large amount of material to be dealt with, it has been found necessary slightly to modify the arrangement of the type, in order to keep the volumes within moderate limits.

The constant increase in the material dealt with is shown by the following statistics :—

Year.	Abstracts.	Year.	Abstracts.
1893 . . .	1130	1903 . . .	2314
1899 . . .	1337	1904 . . .	2309
1900 . . .	1507	1905 . . .	2627
1901 . . .	1647	1906 . . .	2465
1902 . . .	1884	1907 . . .	2737

In view of the fact that the first copy of the Transactions of the Iron and Steel Institute, of which the original edition was a very small one, has long been out of print, and is now exceedingly rare, the Council, at the suggestion of Sir Hugh Bell, Bart., President, decided to have it reprinted. The volume, which was issued in July, contains the inaugural Presidential Address delivered by the Duke of Devonshire, on June 23, 1869, together with papers by Sir Lowthian Bell, Bart., Past-President, Mr. J. Palmer Budd, Mr. J. T. Smith, Past-President, Mr. Edward Williams, Past-President, Mr. R. Howson, Mr. William Menelaus, Past-President, Mr. G. H. Benson, and Mr. Thomas Whitwell. All these authors, with one exception, have passed away, and of the original members of the Institute only thirty now remain on the roll.

A rare and interesting essay on the effect of air and moisture on blast-furnaces, written in 1800 by Mr. Joseph Dawson of Low Moor, was, at the suggestion of Mr. James Riley, Vice-President, reprinted in vol. xxxiv. of the Journal.

MEDALS AND RESEARCH SCHOLARSHIPS.

The Bessemer Gold Medal for 1907 was presented to Mr. J. A. Brinell in recognition of his conspicuous services in the advancement of the metallurgy of iron and steel.

In accordance with the terms of the trust deed, Mr. W. H. Bleckly, trustee of the Bessemer Medal Fund, appointed Sir Hugh Bell, Bart., President, as his co-trustee in succession to the late Sir David Dale, Bart.

Special Andrew Carnegie Medals were awarded in 1907 to Mr. E. F. Law, Assoc.R.S.M. (London), and to Dr. O. Stutzer (Frei-berg in Saxony).

A large number of candidates applied for Carnegie Research Scholarships, and, after careful consideration, four scholarships, each of the value of £100, tenable for one year, and two scholarships, each of the value of £50, were awarded. Details of the awards have been published in the Institute Journal. Particulars of the scheme, printed in the English, French, German, Hungarian, Italian, Russian, Spanish, and Swedish languages have been widely distributed.

APPOINTMENT OF REPRESENTATIVES.

During the year the Institute was represented by the President on the General Committee administering the Government grant for scientific investigations. Mr. R. A. Hadfield, Past-President, and Mr. E. P. Martin, Past-President, represented the Institute on the governing body of the National Physical Laboratory. Mr. Arthur Cooper, Vice-President, and Mr. George Ainsworth, Member of Council, represented the Institute on the Engineering Standards Committee. Mr. William Beardmore, Vice-President, and Mr. George Ainsworth served as representatives of the Institute on the Technical Committee of Lloyd's Register. Mr. W. H. Bleckly, Hon. Treasurer, served as representative on the Court of the Liverpool University, and Mr. R. A. Hadfield, Past-President, as representative on the Court of the University of Sheffield.

Sir Hugh Bell, Bart., President, was, in accordance with the terms of the draft Royal Charter, appointed by the Institute a member of the governing body of the Imperial College of Science and Technology at South Kensington.

The Institute was represented by Mr. W. H. Bleckly, Hon. Treasurer, on a joint committee of learned, scientific, and technical societies issuing publications, for the purpose of endeavouring to secure for such publications a reduced postal rate, and the Institute Council-room was lent for the inaugural meeting of the Committee. The Council-room was also lent for a meeting of the British Science Guild.

Mr. R. A. Hadfield, Past-President, represented the Iron and Steel Institute at the dedication of the building given by Mr. Carnegie as a home for American engineering societies in New York, and presented a congratulatory address from the Institute.

On the occasion of the centenary of the Geological Society, the Institute was represented by Professor A. McWilliam, who presented an illuminated congratulatory address from the Institute.

Sir W. T. Lewis, Vice-President, represented the Institute on the Board of Trade Advisory Committee for iron and steel of the Census of Production Act, of which Committee Sir Hugh Bell, Bart., Mr. J. S. Jeans, Mr. W. Wylie, and Mr. B. H. Brough, Secretary, were also members.

Mr. C. J. Bagley, member of Council, and Mr. T. Nash (Sheffield), were appointed representatives of the Institute to give evidence before the Treasury Committee on the National Physical Laboratory.

The President consented to serve as chairman of the sectional committee on iron and steel in connection with the Franco-British Exhibition, 1908, and a committee of Council was appointed to carry on the work of making the necessary arrangements for the iron and steel section.

A diploma of special merit was awarded to the Institute by the Superior Jury of the Milan Exhibition, 1906.

The Institute was represented on the Advisory Committee of the Engineering and Machinery Exhibition held in London on September 19 to October 19, 1907.

During the year were published the reports of the Departmental Committee on International Exhibitions, of which Committee Lord Airedale, Past-President, was a member, and of the Departmental Committee on check-weighing in the iron and steel trades, of which Committee Mr. G. Ainsworth, member of Council, and Mr. Herbert Eccles, were members.

RETIRING MEMBERS OF COUNCIL.

The retiring members of Council, whose names were announced at the last meeting, are:—*Vice-Presidents*: Mr. W. Beardmore, the Right Hon. Victor Cavendish, M.P., and Sir John G. N. Alleyne, Bart. *Members of Council*: Mr. A. Greiner, Mr. G. Ainsworth, Mr. J. M. While, Mr. Iltyd Williams, and Mr. J. M. Gledhill. No other members were nominated up to one month previous to this meeting in response to the announcement made at the last meeting. The retiring members are consequently presented for re-election.

The vacancy on the Council caused by the election of Sir Hugh Bell as President, was filled by the election of Mr. John H. Darby (Brymbo) as member of Council.

THE IRON AND STEEL INSTITUTE.

ACCOUNT OF INCOME AND EXPENDITURE FOR THE YEAR ENDED DECEMBER 31, 1907.

INCOME.		EXPENDITURE.	
To Entrance Fees	£241 10 0	By Salaries	£1587 14 9
" Annual Subscriptions	4250 8 0	" Office Rent, Cleaning, &c.	457 5 3
" Life Compositions	126 0 0	" Library Books and Binding	70 1 7
" Journal Sales	£453 14 2	" Office Furniture	38 1 2
Do. Reprint, 1869 Volume	25 8 0	" Annual Meeting	64 2 7
" Do.		" Autumn Meeting (Vienna)	319 11 1
Interest on Investments	477 2 2	" Journal Publishing Expenses :—	
" Income Tax recovered, 1906-7	337 7 5	Printing Reprint, 1869 Volume	£1094 0 3
" Bessemer Medal Fund Interest	17 10 11	Do.	61 0 6
Do. Income Tax recovered	£15 4 4	Abstracts	203 14 10
" Do.	0 16 0	Translations of Papers	44 6 8
Interest on Deposit	16 0 4	Postages	170 5 6
" Carnegie Scholarship Fund :—	79 8 4	" Stationery and Printing (including copies of Papers)	1570 7 9
Income on Bonds	£863 6 8	" Postage and Receipt Stamps	395 15 1
Income Tax recovered, 1906-7	45 12 7	" Insurance	157 7 3
" Sundry Receipts	0 0 10	" Bessemer Medal Fund Expenditure :—	2 17 0
		Gold Medal	£215 5 0
		Sundry Payments	0 12 6
		" International Testing Association, Subscription	
		" Telephone	15 17 6
		" Travelling Expenses	5 0 0
		" Sundry Payments	17 0 0
		" Funeral Wreath, King of Sweden	22 6 3
		" Auditor's Fee	47 12 4
		" Carnegie Scholarship Fund :—	11 0 6
		Scholarships	12 12 0
		Medals (Silver)	£500 0 0
		Printing and Stationery	1 15 0
		Do. Volume of Research Memoirs	13 0 9
		Translations	277 12 2
		Advertising	74 8 9
		Balance, being excess of Income over Expenditure :—	7 2 6
		General Account	£883 6 11
		Add Carnegie Scholarship Fund :—	
		Excess of Income over Expenditure	35 0 1
			918 7 0
			£6454 16 3

LIABILITIES	£	s	d
To Sundry Creditors :-			
Journal Printing and Publishing	263	16	3
Journal Postages	68	10	6
Journal Abstracts	87	7	0
Library Books and Binding	11	10	9
Office Rent	105	5	11
Printing and Stationery	8	18	4
Autumn Meeting Expenses	7	10	0
Office Furniture	2	12	3
Carnegie Scholarship Fund :-			
Scholarships due	325	0	0
Sumdries	10	0	11
			£1150 6 11
Subscriptions in advance			72 7 11
Iron and Steel Institute Capital Account			
amount at Credit thereof at 1st Jan. 1907	2095	16	6
Add Excess of Income over Expenditure for the Year	88	6	11
			3879 3 5
Carnegie Scholarship Fund :-			
Excess of Income over Expenditure for the Year	285	0	1
Less Amount at Debit thereof at 1st Jan. 1907	31	4	2
			3 15 11
			£5105 14 2

1908. — i.

ASSETS.

By Subscriptions in arrears, since received	279	10	0
Interest on Investments accrued, due at 31st December 1907, since received	168	18	10
Interest on Deposit	40	8	2
Journal Sales, since received	184	12	0
Telephone Deposit	1	0	0
Investments on account of Life Compositions :- £1380			
North-Eastern Railway 5 per cent. Debenture Stock	1254	17	6
Cash on Deposit			
Do. on Current Account	2500	0	0
Secretary's Balance :-			
At Bank	664	19	5
In hand	188	19	6
	37	7	9
			3870 6 8

£5105 14 2

INVESTED FUNDS OF THE INSTITUTE.

£374 North-Eastern Railway 4 per cent. Preference Stock, purchased at a cost of	£4,297	6	7
£788 North-Eastern Railway 4 per cent. Guaranteed Stock, purchased at a cost of	1,008	14	0
"B" Annuity £79. 4s. 6d. Schode, Punjab, and Delhi Railway, expiring 1908, with a Sinking Fund to replace the amount of Stock, purchased at a cost of	1,999	0	7
"B" Annuity of £50. 1s. 8d. Great Indian Peninsula Railway, expiring 1948, with a Sinking Fund to replace the amount of Stock, purchased at a cost of	1,267	6	0
£700 Midland Railway Corporation Waterworks 3½ per cent. Debenture Stock, purchased at a cost of	751	2	0
£1380 North-Eastern Railway 3 per cent. Debenture Stock, purchased at a cost of	1,264	17	6
	£10,578	6	8

ANDREW CARNEGIE RESEARCH SCHOLARSHIP FUND.

£84,000 Pittsburgh, Bessemer & Lake Erie Railroad 5 per cent. Debenture Bonds.
 £25,000 United States Steel Corporation 5 per cent. Debenture Bonds.

(Signed) W. H. BLECKLY, Hon. Treasurer.
 BENNETT H. BROUGH, Secretary.

I have examined the above Balance Sheet and accompanying Income and Expenditure Account with the Books and Vouchers of the Institute, and certify them to be correct. I have also verified the Balances at the Bankers' and the Securities for the Invested Funds as shown above.

(Signed) W. B. KEEN,
 Chartered Accountant.

BESSEMER MEDAL FUND.

£634 London and North-Western Railway 3 per cent. Debenture Stock.

23 QUEEN VICTORIA STREET, LONDON, E.C., April 24, 1908.

B *

Mr. W. H. BLECKLY, Honorary Treasurer, in presenting his report, said: The financial statements which it is my duty to present to you in the spring of each year, however satisfactory they may be, have a certain monotony about them which is no doubt tedious to most of the members who are waiting to hear something much more interesting; and, in consequence, I will endeavour to make my comments as succinct as possible. However, on this occasion I have to put before you the interesting news that Mr. Carnegie has munificently presented this Institute with a further sum of 11,000 dollars, making, with his previous donation, a total sum of 100,000 dollars. The original funds were provided by Mr. Carnegie for research scholarships, but, finding that the printing of the memoirs was likely to be a strain upon the income of the Institute, he presented the necessary funds for that purpose. This latest donation will be used to cover the whole cost of administration, and thus free the Institute of all expense in dealing with the Research Endowment.

With regard to the financial position of the Institute, the revenue of the year 1907 was £6454, which is slightly less than in the previous year, when £273 was presented to the Institute by the guarantors of the American Entertainment Fund. A slight increase will be noticed in the annual subscriptions. The increase in Journal sales was considerable, and affords gratifying evidence of the appreciation of the Institute's publications by other than members. On the expenditure side the item of salaries shows an increase, as also does the amount expended on the annual meeting, owing to the fact that in 1906 no banquet was held in the spring. The autumn meeting expenses compare favourably with those incurred at other meetings abroad. Indeed, neglecting the cost of souvenir presentations, the eminently successful Vienna meeting in 1907 cost the Institute less than the long-remembered Vienna meeting in 1882, notwithstanding that there were three times as many members present at the late meeting. Journal publishing expenses show a substantial decrease. The receipts from the Carnegie Scholarship Fund met the expenditure incurred and covered the last year's deficit of £31, leaving a small surplus. The investments of the Institute remained unchanged during 1907.

The PRESIDENT, in moving the adoption of the Report and Statement of Accounts, said he had to refer to one or two matters not specifically mentioned in the report. In the first place there had been circulated a small pamphlet describing the new premises into which the Institute had quite recently moved. He believed they would be found in every respect a very great improvement on their late offices. They would afford facilities of which he hoped the members would make every possible use and would find a very great convenience. The library was much better installed, and had been entirely re-organised, and a room was provided for students who desired to consult the works which it contained. In addition to that they had provided a reading and smoking-room. The latter title seemed an appropriate one, regard being had to the avocation of most of the members, and it would, he hoped, prove in its other significance a welcome addition to the conveniences offered by the Institute. With reference to the Franco-British Exhibition, he hoped when the members went to see what had been done there, they would think that the Committee of which he was the Chairman had properly discharged the duties which they undertook in causing the great industry to be represented in somewhat a different form from what had ever been attempted before, a form which he hoped would be regarded as being of interest, not only from the mere popular point of view, but also as an educational object. They had attempted to show the cause and reason for the location of the pig iron industry throughout the United Kingdom in a geographical way, and he thought they might claim that they had done so in a way which would do honour to the industry which, after all, lay at the base of their proceedings. There was also a difficulty in making an interesting exhibit of pig iron. He thought they had overcome that difficulty by sinking the personalities of the makers, and putting in the forefront the district in which the pig iron was produced, and by endeavouring to show how and why those particular parts of England had come to be the location of the trade. With regard to the other departments of the iron and steel industry, the moment pig iron was passed matters became much more

personal in their character, and there, with the very hearty and active co-operation of those sections of the trade, they would, he hoped, show a very excellent exhibit at Shepherd's Bush, whenever the Exhibition was ready. The Institute, and those who represented them, were not in default, and were perfectly ready to put their exhibits in place as soon as the place was ready to receive them. The report mentioned the success of the Vienna meeting, and he was sure he could use no language which would be regarded as hyperbolic by any person who was present at that meeting, in praising the reception which was accorded to them at the hands of every section of society in the Austro-Hungarian capital from the Emperor downwards. The unfortunate pressure on his Imperial and Royal Majesty's time prevented them from having the honour of being received by that most distinguished man. His Majesty's place was taken by the Archduke Frederick, and of his reception of the members, and of his courtesy, it was impossible to speak in too high terms. If he did not mention any other names, it was because it would be a mere catalogue of hyperbole to say how magnificently every single gentleman, every Institution with which they came in contact in the Austro-Hungarian Empire, did their very utmost to make their visit the extraordinary success, and the most agreeable function which it proved to be.

He had to turn from that agreeable subject to one which he was certain would cause much grief to every member of the Institute who was acquainted with the distinguished man whose name he was about to mention. They had but recently received the intimation of the very sudden death of an old and trusted friend of the Institute, in the person of Dr. Hermann Wedding, an Honorary Member. Dr. Wedding never omitted an opportunity to do a kind act for the Institute; he was always ready with his advice and assistance whenever it was possible to do anything in the service of the Institute. In him they had lost a very excellent friend, and those who, like himself, had the honour of his acquaintance, had lost a most charming and delightful personality. He had had the honour of knowing not only Dr. Wedding but also his distinguished father. He looked

back over a period longer than he cared to mention, to the time of his meeting Dr. Wedding's father, when he was Master of the Mint in Berlin, a long way back in the nineteenth century, and the delightful recollection that he had of the father was kept alive every time he met the son. He hoped the members present would not think he was making too large a demand upon them if he invited them, in testimony of the regret which all who knew him would feel, and in appreciation of the services which those who did not know him might have indirectly received at his hands, to signify their deep regret at his death by rising.

The members having resumed their seats, after rising in response to the President's invitation,

The PRESIDENT said that the Council had directed a proper intimation to be sent to the family, and he had now formally to move from the chair that the report be received and adopted.

Mr. JOSEPH ADAMSON (Manchester), in seconding the adoption of the report and accounts for the year 1907, said the progress of the Institute was shown by the increase of members and by the financial position. The Institution was fulfilling the objects its founders had intended it to fulfil; it was an Institution that was started with the intention of benefiting every one connected with iron manufacture, whatever country or clime he belonged to. It was perhaps unnecessary for him to repeat what he once heard a gentleman in Manchester say when seconding a motion of a similar character, to the effect that "if one was dissatisfied with what had been said, and would come outside, it could probably be squared in five minutes." The report was an extremely satisfactory one, and he had great pleasure in seconding the resolution.

The resolution was passed unanimously.

Mr. W. F. BEARDSHAW (Sheffield), in proposing a vote of thanks to the President, the Hon. Treasurer, and the Council for their services during the past year, said it would require

very few words from him to commend the resolution to the approval of the meeting. He had been a member of the Iron and Steel Institute for nearly twenty years, and had never seen the time when the members of the Council had done their work more energetically than they had in the last year. In addition to the intellectual entertainment provided for the members, he was quite sure that no scientific society did more for the comfort and convenience of its members, and that was evidenced by the additions to the new offices, which he hoped many members would take the opportunity of visiting during the time they were in London. The report had particularly dealt with the very successful excursion to Vienna. He was present there, and, with a large number of others, they were particularly proud of the President, of the Council, and of the Secretary, Mr. Brough, not only for the capital arrangements which they made in every detail for the comfort of the members, but likewise for their linguistic attainments. Such visits were laying deeper and broader foundations than mere scientific observation. They were laying the foundations for international understanding, and when they had members such as the President and the Secretary to lead them, he felt sure that the visit would be of lasting good in the relations between this country and the Austro-Hungarian Empire.

Professor W. GOWLAND (London), in seconding the resolution, said all present were fully sensible of the work which the President and the members of the Council had done in the interests of the Institute, and that its success was entirely due to those efforts.

The resolution was carried with acclamation.

The PRESIDENT said that, on his own behalf and on behalf of his colleagues, he had to thank the meeting for their kind vote. Mr. Beardshaw was too kind in his reference to the polyglot acquirements of the Council. He had to confess that when he was invited to respond to an address in Czechish, he was a little "checked," and he felt bound to have recourse to

the language which, indifferently though he spoke it, he spoke with more fluency than any of the others which he possessed, and he answered in English.

PRESENTATION OF THE BESSEMER MEDAL.

The PRESIDENT said it afforded him peculiar pleasure to have the honour of presenting Mr. Benjamin Talbot, whom he would venture to describe as a neighbour and friend, with the Bessemer Medal on behalf of the Iron and Steel Institute and their Council. There was no higher honour that they could confer on their members than the presentation of this medal. It carried with it the recognition of services rendered to the great industry in which they were all engaged; he would venture to assert that on no previous occasion had the recipient been worthier than on the present. Mr. Benjamin Talbot had brought to the business with which he was connected all those qualities which went to make successful his participation in the very interesting matters which formed the subject of their occupation: he had not only that which was of immense and indispensable importance, the scientific outlook, but he had also what was even, if it were possible, more indispensable, practical knowledge and experience. He felt sure no one present would deny the importance of the first, and one of the objects of the Institute was to implant it more strongly, if that were possible, in the minds of those engaged in the industry. Their efforts were unremittingly put forth to emphasise the necessity of scientific acquirement. But while they did that, while they had not omitted from time to time, in their choice of recipients of the Bessemer medal, to bring that prominently before their members, they had ever before them the necessity of that practical experience without which even the most complete knowledge of the scientific principles of their avocation would be of little avail. He ventured to assert that in Mr. Talbot they had combined the two. They were presenting him the medal not only because he conducted a most interesting series of experiments on a somewhat remote scientific aspect of their industry, that of segregation, but also because he had shown them the direc-

tion in which they all of them believed the industry ought to move in the future. If, speaking generally, one were to be asked in what way was any industry to make progress, he should say it would be in the substitution of continuous for periodic or spasmodic efforts. Speaking to that practical meeting, to men fully acquainted with the various phases of industry—for there were many present who were not only ironmasters, but also knew other branches of the industry—he would say that an industry which could succeed in realising continuous progress in place of intermittent progress had made an enormous stride. He might draw illustrations from the blast-furnace itself, where one of the greatest advances was that of making the operation a continuous one. The continuous steel furnace which was known by the name of Talbot possessed that peculiarity. He need not say he was not going to embark on controversial subjects: it might well be that between its complete realisation and the present some time might elapse, but that the direction was the right one, whether Mr. Talbot had solved the problem or not, no one, he thought, would deny. The Institute therefore presented the Bessemer medal to Benjamin Talbot not only as the experimenter, but also as the pioneer, and it gave him, as he said in opening, a peculiar satisfaction that it should have fallen to his lot to make this presentation. He had the honour to hand Mr. Talbot the medal, with every wish for his continued success in the career which he had chosen, and he hoped that he might have the pleasure of congratulating him again and again on the progress he was making in the direction indicated.

Mr. BENJAMIN TALBOT said he had great difficulty in finding adequate words in which to thank the Council as he should like for the great honour they had conferred upon him by giving him the Bessemer medal. He need hardly say, however, that it would be most highly treasured, as it was most gratifying when one's work was judged by those competent to judge in such a manner, and such an award was doubly precious when it was presented with such kind and gracious words as those which the Chairman had expressed. He had

been wondering what caused him to start on the basic open-hearth process, considering he was being trained as a Bessemer man, and he had to thank a well-known member of the Institute for first drawing his attention to the possibility of the process. In 1886 he was in the Ebbw Vale Works as a learner of the Bessemer process, trying to pick up the practical details of that process. Whilst there he received a copy of *The Ironmonger*, containing Mr. Harbord's well-known paper read before the Institute in 1886. It was the study of that paper which caused him to investigate the basic open-hearth process, and it was not long before he had a small furnace at work with some liquid metal, and from that day to this he had endeavoured to improve the practice of basic open-hearth steel. He mentioned that because it showed writers of papers that they never knew who benefited by them, and it was due to the policy of the trade papers in publishing those papers so promptly that their readers, who, of course, had a much wider range than the members, got them, and so many people studied them who like himself, at the time, were not actually members of the Institute. He again thanked the Chairman and the Institute for the great honour they had done him in giving him the Bessemer medal.

A paper by Mr. Andrew Lamberton (Member of Council) was then read and discussed, after which the President, having been obliged to attend the opening of the Franco-British Exhibition, apologised to the meeting for not being able to remain, and

Mr. JAMES RILEY, Vice-President, thereupon took the chair for the remainder of the session.

A paper by Dr. T. E. Stanton (Teddington) was then read and discussed, and a hearty vote of thanks was, on the motion of the Chairman, accorded the author. Papers by Mr. James E. York (New York) and Professor B. Igewsky (Kiev) were subsequently taken as read, and the meeting adjourned at 1.30 p.m. to the following day, May 15, 1908.

The chair having been taken at 10·30 A.M. by the **PRESIDENT**, the following list of awards of the Carnegie Research Scholarships was read :—

CARNEGIE RESEARCH SCHOLARSHIPS.

Having carefully examined the reports submitted by last year's Research Scholars, the Council of the Iron and Steel Institute have decided that the Gold Medal should be awarded to Dr. Carl Benedicks, of Upsala, Sweden.

The reports submitted by the eight holders of Research Scholarships are considered to be of sufficient merit to warrant their publication in full in the Journal of the Institute.

Having carefully investigated the numerous applications received, the Council have awarded Research Scholarships each of the value of £100 to :—

T. Baker (South Wales), R. F. Böehler (New York), W. Giesen (Mexico), E. Preuss (Germany), and L. P. M. Révillon (France).

The recipient of the Carnegie Gold Medal for Research, **CARL A. F. BENEDICKS**, is a doctor of philosophy of the University of Upsala, Sweden, where he is lecturer in physical chemistry. He has had considerable practical experience in metallurgy and in electric smelting. He is a member of the Iron and Steel Institute, and the author of numerous memoirs on iron carbon alloys.

The following are brief notes of the careers of the recipients of Carnegie Research Scholarships of the Iron and Steel Institute for 1908 :—

THOMAS BAKER, M.Sc., Assoc.I.C. (Llanely, South Wales), was educated at Wolsingham Grammar School and at Durham University. He received his metallurgical training in the laboratory of Messrs. John Rogerson & Co., and at Sheffield University. He contributed, with Professor Arnold, to the Iron and Steel Institute, a paper on the influence of silicon in iron.

RICHARD F. BÖHLER (New York) was educated in Vienna and Berlin, and received his metallurgical training at the Berlin School of Mines and at the Kapfenberg Steelworks. He has contributed papers to the Austrian Society of Engineers and Architects and to the New York Academy of Sciences.

WALTER GIESEN (Mexico) was educated at Gladbach and Essen in Germany, and received his metallurgical training at the works of F. Krupp and Thyssen & Co., and at the technical schools of Hildburghausen and Carlsruhe. He is now manager of the rolling-mills of the Monterey Steelworks, and has published six papers on metallurgical subjects.

ERNST PREUSS (Darmstadt) was educated at Berlin, and received his technical training at the works of the General Electric Company, Berlin, and as assistant to Professor Martens. He is now superintendent of the laboratory for testing materials at Darmstadt, and has published eight papers on metallurgical subjects.

LOUIS P. M. RÉVILLON (Paris) was educated at the Paris Ecole Centrale, and is now director of the testing laboratories of Dion Bouton & Co., Puteaux. He is the author of a treatise on special steels (Paris, 1907).

ANDREW CARNEGIE GOLD MEDAL.

The PRESIDENT, addressing Dr. Carl Benedicks, said it afforded him very great pleasure on behalf of the Institute to present him with the Gold Medal of the Carnegie Research Fund, and to congratulate him and themselves on having the honour of numbering him among those to whom the Carnegie medal had been awarded. He had to thank Dr. Benedicks for the valuable researches which he had made on the cooling power of liquids, on the testing of velocities, and on the constituents of steel, investigations of a very elaborate character and very well worthy of the extremely high traditions of metallurgy in Sweden. It was a great satisfaction to them again to honour that country which was the classic home of the intelligent investigation of the properties of metals, and in the person of Dr. Benedicks they were very glad to have the opportunity of once again showing how highly they valued the contributions of members of his nation to the science with which they were concerned. He thought he might congratulate the Institute, and the founder of the Medal and of the Research Scholarships, on the extremely satisfactory results of

that award. They had every reason to be extremely content with the persons to whom the awards had been made. In one respect especially he would like to dwell upon the fact that the cosmopolitanism to which Sir Edward Grey had referred at the dinner on the previous evening was well marked in the awards that year. They had on the list of awards a gentleman from South Wales, a gentleman from New York, a gentleman described as from Mexico, but in fact, he believed, a citizen of the Austro-Hungarian monarchy, a gentleman from Darmstadt, and a gentleman from Paris. Therefore the length and breadth of the world had been searched to find people to whom to make these awards, a result which could not fail to be very satisfactory to all concerned in the foundation.

The PRESIDENT then handed the Gold Medal to Dr. Carl Benedicks.

Papers by Mr. W. Rosenhain (Teddington), Mr. C. de Schwarz (Liège), Mr. J. Wesley Lambert (Woolwich), Mr. F. J. R. Carulla (Derby), and Mr. E. H. Law (London) were then read and discussed, votes of thanks being awarded the respective authors.

The PRESIDENT moved, "That the best thanks of the Iron and Steel Institute be and are hereby tendered to the President, the Council, and the Secretary of the Institution of Civil Engineers for the use of their rooms and for the facilities afforded for the present meeting." He said year by year they had to record their thanks for the extreme hospitality in granting the use of these most convenient rooms for the purposes of their annual meeting, and it gave him great pleasure again to invite the meeting to express their thanks.

Sir J. G. N. ALLEYNE, Bart., Vice-President, seconded the resolution, which was carried with acclamation.

Mr. W. R. WEBSTER (Philadelphia) moved, "That the best thanks of the Iron and Steel Institute be and are hereby tendered to the President for his able conduct in the chair."

Mr. E. J. LJUNGBERG (Sweden) seconded the resolution, which was carried with acclamation.

The PRESIDENT said his thanks were once again due to the members for their very great kindness to him while he had been in possession of the presidential chair. He had to look back so far to his tenure of the chair with the undivided satisfaction of feeling that he had made very few mistakes and those only the mistakes of invincible ignorance, and that, where he had made mistakes, they had been willing to forgive him. He thanked them for having once more recorded their appreciation of the small services he had been able to render.

MIDDLESBROUGH MEETING.

The PRESIDENT said that the indefatigable Honorary Secretary of the Middlesbrough Reception Committee had caused to be placed in his hands a communication reminding him that he had forgotten what he regarded as quite the most essential part of the meeting, namely, to tell the members that Middlesbrough was looking forward to their coming in their hundreds in the autumn. They had not been there for twenty-five years, and Middlesbrough thought it was due that they should come back. They were preparing to offer them the hearty hospitality for which he thought the north was renowned. They did not pretend that they could compare with the brilliance of Sheffield two years ago, but they did hope that they should be able to show them something that was interesting, and they were sure that they would be able to give them a most hearty welcome.

IMPROVEMENTS IN PLATE ROLLING-MILLS.

BY ANDREW LAMBERTON, MEMBER OF COUNCIL.

THE manufacture of steel plates, entering into the construction of ships, boilers, girders, &c., has of recent years made remarkable progress, and now constitutes one of the most important branches of the iron and steel industry. The progress has been principally in the direction of increasing the output capacity of mills, with the result that, compared with those of twenty years ago, present-day improvements have resulted in doubling, and in some cases even trebling, capacity. This result has largely been achieved by improvements effected in the details of the accessory machinery throughout the mill plant. Electrically-driven live roller-tables, which are now fitted at both sides of roughing and finishing mills; electrically-driven transfer gears; and the very efficient drafting arrangements—also operated by electric motors—have greatly reduced the time occupied in the operations of handling and rolling plates. Improvements have also been made in slab-heating furnaces, which have been increased in capacity and in power to heat rapidly, and, served as they now are by electric-charging machines, have reduced very considerably the time required for charging, heating, and withdrawing slabs for rolling-mills. These improvements in detail have had the effect of increasing the output capacity; but the most important improvements have been effected in rolling-mills themselves, which have been greatly strengthened in all their parts, and their speed accelerated threefold. This great increase in speed is very beneficial, owing to the larger amount of work expended upon the plate in a shorter time, economising heat, and enabling plates to be rolled down to thin gauge with comparative ease and safety. The thinner the plate, the more difficulty there is in rolling it, and, unless sufficient speed be given to the rolls, these plates become too

cold to roll down to thin gauge. The increase in speed has now rendered it possible to produce plates of a size and gauge which were impossible with slower-running mills.

During recent years a large demand has arisen for thin plates, and the question as to what type of mill is best adapted for rolling such plates is one of very considerable interest to steelmakers. The three principal conditions which platemakers must fulfil are:—

1. Quality, represented by the usual tensile and bending tests.
2. First-class surface finish throughout.
3. Close adherence to gauge thickness.

It is well known that these conditions are imposed much more rigorously in this country than in America or on the Continent of Europe. Here surface finish must be first-class, and adherence to gauge thickness must be within $2\frac{1}{2}$ per cent. over or under.

In America steel-plate makers are not under such stringent conditions, and the writer has seen thin plates being rolled in which a margin of 15 per cent. variation in thickness was accepted. Were it not for the stringency of the conditions to which he has referred, the probability is that plate rolling-mills of the American three-high type would have been adopted in this country before this time. It is unquestionable that for thin plates the three-high mill has some advantages; but, unfortunately, it has the great drawback of being unable to maintain high-surface finish on plates for more than two or three days, when the rolls require to be changed. This defect is inherent in the design of the mill where the roughing-down of the slab and the finishing of the plate are done in one set of rolls, causing rapid deterioration of their surfaces. The usual practice is to use a top roll and a bottom roll of equal diameter with a mid roll of two-thirds their diameter. At every pass of the plate, whether between top and mid, or bottom and mid, the mid roll does work, so that twice the work is put upon it that the top and bottom rolls are required to do, and, as it has only two-thirds of their surface, it wears much more rapidly, the surface becomes quickly injured,

and necessitates the changing of the rolls every two or three days, which is a drawback of a very serious nature.

The author observed the outputs from three-high mills both in America and on the Continent, and, whilst the surface finish of the plates delivered during the first twenty-four hours' working was good, there was a subsequent steady deterioration in quality of surface finish, until the rolls had to be taken out for re-dressing. To meet this the practice is to roll all plates requiring the highest finish during the first twenty-four hours' working of the mill, and devote the subsequent one or two days' working to plates which do not require such fine surface or close adherence to gauge thickness. There can be little doubt that it is largely this difficulty of surface-finish and adherence to gauge thickness, together with the undoubted complication of the three-high mill, which has prevented its adoption in this country, where the conditions of finish and thickness are so rigorously enforced. Our steel-makers have, with practical unanimity, adopted the two-high reversing-mill as the best to meet the conditions obtaining here, and there can be no question that the surface finish got from two-high reversing-mills is superior to, and can be maintained with greater regularity and for a much longer time without changing rolls, than where three-high mills are used. The drafting of the rolls is also much simpler in two-high mills, and admits of more ready adjustment than when three rolls have to be regulated to work together with perfect exactitude. The live roller tables in two-high mills are likewise much more reliable in that they are fixed, and can be made as heavy and strong as desired, whilst in three-high mills these tables have to rise and fall at each pass, and therefore their mass and inertia have to be reduced to the lowest possible point commensurate with safety. This cutting down of weight tends to reduce the margin of safety, and frequent breakages occur, and it is well known that these tables are very costly in repairs, and in many cases complete spare tables are kept ready to put in when a breakdown occurs, so as to minimise the delay to the mill.

Another very important advantage possessed by the two-high reversing-mill is that, when roughing down slabs, during

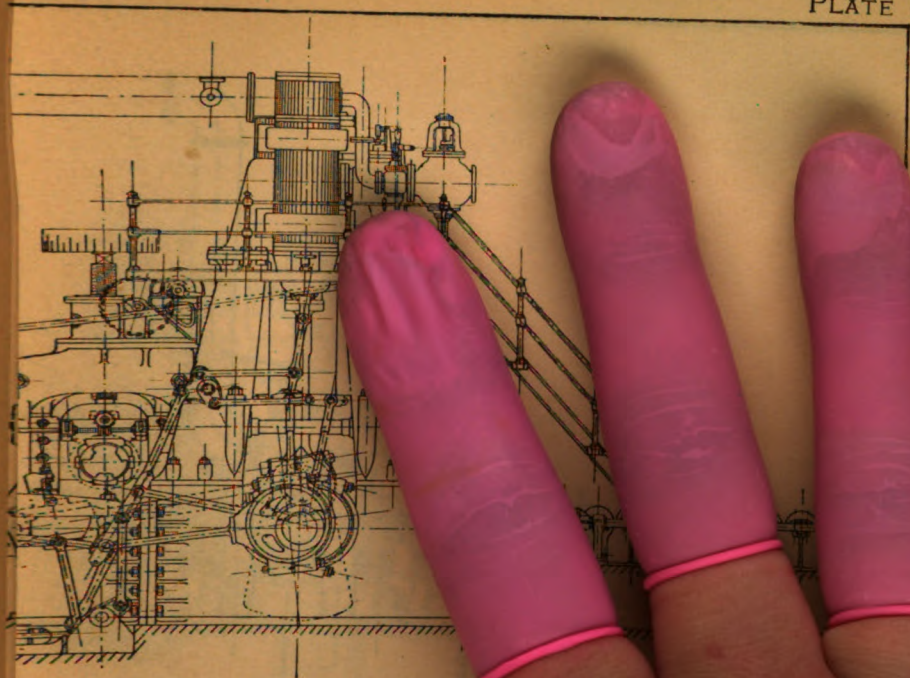

VATION



which the passes are short, the mill can be driven at slow speed, so as to minimise the shock when the slab enters the rolls, whilst during the long passes the speed can be accelerated to any desired extent compatible with safety. The writer has taken notes of the speed at which reversing-engines are regularly driven, and finds 140 revolutions per minute quite common. This is quite twice the speed of three-high mills, so that the slowing down during the initial passes is amply compensated for before the finish. This method of working is obviously much easier on the mill plant than where the slab enters the rolls at full speed, as in the three-high system causing violent shock and increased liability to breakage.

These are some of the practical considerations that have influenced steel-plate makers in choosing the type of mill best suited at all points to meet the stringent conditions imposed, and, so far, the all but unanimous choice of the two-high reversing-mill has been fully justified by results.

It is to be observed, however, that two new installations of three-high mills have been made during the last few months, one in Scotland and one in England, and the results from these will be watched with much interest.

The author has thought it might prove of interest to members of the Institute if he gave a description of a new form of plate-mill, having rolls 30 inches diameter by 6 feet 6 inches long, which he has designed specially for rolling light plates, but which is equally suitable for ordinary ship and girder plates, now successfully at work at the Glasgow Iron and Steel Works, Wishaw. This mill, which is illustrated in Plate I., possesses some quite novel features, for which the following claims may fairly be made :—

1. Simplification in the operation of the mill.
2. Reduction in the amount of machinery required.
3. Reduction in the work done by finishing rolls, and consequent reduction in wear of same.
4. Acceleration in delivery speed of finishing rolls, and equalisation of power used in roughing and finishing rolls.
5. Final delivery of plates, straightened and free from wave.

6. Reduction in space occupied by the whole plant.
7. Large output capacity.
8. Economy in steam consumption of driving engine.

1. *Simplification in the Operation of Mill, and 2. Reduction in the Amount of Machinery required.*—This is accomplished by arranging the roughing and finishing rolls in tandem, instead of the usual practice of arranging them in the same extended line. The slab is first reduced in the roughing rolls, and finally in the finishing rolls. During the process of roughing-down, the top finishing roll is held up clear by its hydraulic balances, and the plate under treatment passes freely through the finishing rolls until reduced to the thickness ready for finishing, when the upper roughing roll is raised, and the upper finishing roll lowered, and the subsequent finishing of the plate takes place through the finishing rolls. It will be observed that, by this means, two sets of live roller tables, which in the ordinary type of reversing-mills would be fitted at the front and back of the finishing rolls, are rendered unnecessary, one set of two tables serving both roughing and finishing mills. Further, by this new arrangement the transfer or skid gear, required in the former type of mill to transfer the roughed-down plate across to the finishing rolls, is also done away with, these constituting a very substantial reduction in the machinery employed, and decidedly simplifying the operations, as the slab to be rolled never leaves the straight line of travel during the whole process of rolling, and passes out, a finished plate, in the same line as the original slab is received at the commencement of the operation.

3. *Reduction in the Work done by Finishing Rolls and consequent Reduction in Wear.*—In the ordinary type of mill, where the roughed-down slab has to be transferred sideways to the finishing rolls, the practice is to make this transference whilst the plate is still of considerable thickness, that it may not cool too rapidly during the process, so that, generally speaking, as many passes are made in the finishing rolls as in the roughing-down rolls. The author considers this bad practice, inasmuch as it imposes a great deal more work and entails much more wear on the finishing rolls than is necessary.

The operation of finishing should be done with the minimum number of passes, so as to reduce the wear on the costly finishing rolls to the lowest possible point, and maintain their surfaces perfect as long as possible. This new form of mill is specially designed to effect this, as the roughing-down process can be carried on during 80 per cent. of the whole operations of rolling a plate, owing to the fact that it never requires to leave its direct line of travel, and the finishing process, representing some 20 per cent. only of the whole work, is all that need be put on the finishing rolls. It is obvious that a very considerable saving must be effected in the finishing rolls, which have their work so substantially reduced, and their surface will be maintained in good condition for a much longer time. Further, the expense in changing and dressing rolls will be greatly reduced, and stoppage of the mill rendered less frequent.

4. *Acceleration in Delivery Speed of Finishing Rolls and Equalisation of Power used in Roughing and Finishing Rolls.*—From careful observations and diagrams taken from engines driving two-high plate rolling-mills it has been found that the process of roughing-down requires very considerably greater power than that for finally finishing the plate in the hard rolls. This means that the engine, which must be of sufficient power to give out the maximum demand made upon it, is over power when the finishing process is in operation, and the writer has utilised this excess power in accelerating the speed of the finishing rolls over that of the roughing. This results in the double advantage of equalising the load upon the engine during the whole of the operations and consequently increasing its efficiency, and also of providing a most useful increase in speed during the final passes when finishing the plate, which, when rolling thin plates, is of very great importance.

In the ordinary type of two-high reversing-mill the power required for driving both roughing and finishing rolls is transmitted through the bottom roughing roll, and as it is the practice to partially rough down the slab whilst the preceding plate is being finished in the hard rolls, this doubles the strain on the neck and wobbler of the lower roughing roll and greatly increases the wear and tear on them. This

system of working is followed in order to increase the output capacity of the mill, but it is obviously obtained at greatly increased cost, as the driving-engine must be able to develop nearly twice the power required where work is only done in one set of rolls at a time, and is consequently much more costly. At the best, it is only a few of the short initial passes that can be done simultaneously with the finishing of the preceding plate, so that for quite three-fourths of the whole operation only one piece is in the rolls, and the engine is then twice as powerful as is necessary and must do the work with a substantially lower efficiency than when the load on the engine is kept constant during the whole operation. Further, this large surplus engine power is a source of danger when by accident a stall occurs in the mill, as the shock and strain induced in bringing the engine suddenly to rest are much intensified by its greater power and mass of moving parts.

5. *Final Delivery of Plates, Straightened and Free from Wave.*

—In mills driven at high speed there is a tendency for the plate to become waved, particularly if it is of thin gauge, and the higher the speed the more pronounced is this tendency. To correct this, during the final pass in the finishing rolls the roughing rolls are also put down in light contact with the plate, and the mill then practically forms a four-roller mangle, which very effectually flattens out the plate before going to the shears.

6. *Reduction in Space occupied by the whole Plant.*—This consideration may not be of such importance where new works are being laid out; but in carrying out improvements in existing works the question of space occupied is almost always one of great importance. The total space occupied by a two-high reversing-mill of the ordinary type, measured over its extreme length and including the driving-engines, amounts to 70 feet. A mill of the same size and capacity of this new design occupies 42 feet, representing a saving of 40 per cent. in the space occupied without in any way being more congested in its arrangements. This reduction in space is effected by (1) the design of the engine, which is of the vertical and horizontal type, and occupies only half the floor space of the ordinary

side-by-side reversing-engine; and (2) the design of the mill, in which the whole space occupied by the finishing-mill, together with its two live-roller tables and transfer gear, is saved.

7. *Large Output Capacity.*—This is obtained (1) by the simplification of the operation of the mill, in which the transference of the plate from roughing to finishing mill is abolished and the time taken for this operation saved; and (2) by the acceleration of the speed of the finishing rolls, which are driven 15 per cent. faster than the speed of the engine. The result is that a plate of, for example, 5 feet \times 30 feet \times $\frac{5}{8}$ inches can be rolled in two minutes, and if this rate of feed could be kept up the output of such plates would be 400 tons per day of ten hours. In rolling to thin gauge the slab is thinner, and the time taken for a plate of, for example, 5 feet \times 30 feet \times $\frac{3}{16}$ inches is two and a half minutes, or at the rate of 130 tons per day of ten hours.

8. *Economy in Steam Consumption.*—The steam efficiency of rolling-mill engines has not in the past been conspicuous except for its absence; but much greater attention has been directed towards this subject lately, and substantial improvement has resulted. The engine driving the mill described is of the vertical and horizontal type, compound condensing, and has a high-pressure cylinder 42 inches diameter, and a low-pressure cylinder 67 inches diameter by 4-foot stroke. The steam-pressure is 160 lbs. per square inch, the exhaust is connected to a central condensing plant giving a vacuum of about 24 inches, and the engine under these conditions develops the exact amount of power required. To ensure quick reversing, the handling valves of both high-pressure and low-pressure cylinders are connected and worked in unison from the same starting handle as is now usual in modern compound engines. The closing of both these valves simultaneously acts as a most efficient brake, stopping the engine quickly, and preventing racing at the finish of the passes. The resulting increase in pressure in the receiver is then available for accelerating the speed of starting for the return pass, and so the efficiency of the whole operation is substantially improved.

Before closing, the author desires to refer to a matter in

regard to which there seems to be some difference of opinion in rolling-mill practice. The question as to whether, in rolling plates, the rolls should be worked wet or dry is practically settled so far as regards the finishing rolls; but many makers still work roughing rolls dry. It seems only reasonable to believe that, if all rolls could be worked wet, it would greatly extend their life, and would prevent necks overheating and cutting into their bushes. The solution is to be found in the increased speed of driving, which enables plates to be rolled with such rapidity that the cooling effect produced by working the rolls wet is discounted by the heat generated by the work expended on the plate in reduced time. From careful experiments made on a large number of plates rolled from the same slabs it has been ascertained that the surface quality of plates rolled when both roughing and finishing rolls are worked wet, is very distinctly superior to those produced when only the finishing rolls are worked wet. This clearly points to the advisability of all plate rolls being worked wet; and when consideration is given to the increased durability of the rolls, necks, and brasses, and the reduction of frictional losses, the advantages gained by the great increase in the speed of rolling which has made all this possible are clearly demonstrated.

The performance of this new type of plate-mill described in the paper has now been proved in actual daily work to be of the most satisfactory character, all the aims of the designer being more than realised, and he ventures to hope that in bringing it before the members of the Institute it may have proved of some interest.

DISCUSSION.

Mr. JAMES RILEY, Vice-President, said that it was only on comparatively few recent occasions that Mr. Lamberton had addressed their meetings, but whenever he had done so he had conveyed the impression of being thoroughly conversant with the subjects that he discussed, possessed of a wide fund of information, and able to enunciate his ideas in vigorous and lucid language. The same characteristics were evident in his admirable paper, the first, if the speaker recollected rightly, he had submitted to the Institute. The members would all agree in conveying to Mr. Lamberton the assurance that the very modest hope he expressed at the end of the paper had been realised, and they would be glad to have further interesting matter of the same kind, or some other, from him. He himself had had the pleasure of knowing Mr. Lamberton for a great number of years, he thought twenty-five, and during that period they had not only discussed many branches of subjects similar to those of the paper, but on more than one occasion had collaborated a little. It was therefore a great pleasure to him to know of Mr. Lamberton's latest achievement. Year after year Mr. Lamberton had devoted careful and prolonged study to the various parts of the machinery used in the manipulation of steel, seeking to discover their weak points, and endeavouring to eliminate them, and to remove any obstructions that became apparent in the way of increased productive capacity, and he had accomplished a great deal in that direction. Mr. Lamberton gave an indication of the progress which had been made in the manufacture of plates during the past twenty years, and he did not exaggerate when he stated that the output had been trebled in that period. Thirty years ago, when he (Mr. Riley) went to Scotland, the output of the plate-mill at the Hallside Works of the Steel Company of Scotland was 80 tons per week for one shift, and when he pressed and insisted upon larger outputs than this he was warned by their practical workmen at that time that it could not be done; if they attempted to do what he wished, the rolls would, he was told, get red-hot and they would burst, and there would be no end of trouble. That was with an output of about 80 tons a week. He was not quite sure what they had reached now, but it would be about 2000 tons weekly. Instead of the output being trebled, it might be said to have been multiplied twenty-fold in the thirty years to which his experience extended. He could not say that he was prepared to agree entirely with Mr. Lamberton's conclusions with regard to the three-high mill. About fifteen years ago he (Mr. Riley) put down the first three-high mill, and until recently the only one that had been erected in Great Britain. The comparison between that mill and the then existing two-high rolling-mill was most striking. It was not sufficient to talk of the weight of the plates that were turned out by the old mill and the three-high mill; it was necessary to remember the speed at which that mill ran, and the number of plates rolled. It turned out about three times the weight

of plates per hour that the old mill alongside it turned out. There were complications about that mill; but two gentlemen whom he saw present, his assistants at that time, Mr. Cunningham and Mr. Duff, carefully thought over the body of the mill, and adapted it for a good many more purposes than were at that time, he thought, contemplated in America. They worked over the body of the mill, as he might call it—that was, the screwing gear and the side rolls; it was a universal type of mill, intended to roll the edges of the plates as well as the flat surfaces, and that part they gave great consideration to. Some of his friends in America who had sent him the drawings of the mill sent very complete drawings of the tables. Those he handed over to Mr. Cunningham and Mr. Duff, and requested that they should make them without any alteration whatever. Those tables were a source of trouble, as Mr. Lamberton pointed out. The complications in them, the weakness in parts, were extremely annoying. But he thought it was possible to correct them, and they prepared to do so; but circumstances intervened and the investigation was stopped. So far he disagreed with Mr. Lamberton in his comparison of the three-high mill and the old two-high mill; but he at once conceded that if he had to choose between that three-high mill and the one which Mr. Lamberton had submitted to the meeting to-day, he should agree with him entirely. He thought Mr. Lamberton had fully justified all the points he had submitted, except, perhaps, one. He did not feel so clear in his mind that Mr. Lamberton had not introduced a good many complications into the motor part of the plant, which might be troublesome. If that was all right, the other portions of the mill, he thought, deserved every word of praise that Mr. Lamberton had used. He believed that he could roll thin light plates and finish them 80 feet long. Now it was quite evident that if that could be done the economy in the proportion of scrap that would be made would be very great. He congratulated Mr. Lamberton on his latest achievement. He thought he had undoubtedly reached the point he had been aiming at for a long time, of being, if not in the forefront of the whole of the trade and manufacture of that class of machinery, at least very nearly so.

Mr. J. H. HARRISON (Middlesbrough) said that he quite agreed with the great majority of the proposals that Mr. Lamberton had made. He thought that the mill was in every way one that was likely to prove satisfactory. But there were some points on which he could not quite agree. Mr. Lamberton spoke of one pair of rolls being let down in order to form a four-roller mangle. He did not think the mangling of the plates in that way would have a very great effect. Not only so, but Mr. Lamberton said that the finishing rolls travelled 15 per cent. faster than the roughing rolls; and, in that case, if the roughing rolls were put down so that they came in contact with the plate at all, then the plate, by reason of its high velocity in the finishing rolls, would be dragging through the roughing rolls. Either the rolls would be down too hard, and there would be excessive

work to be done because the plates stretched, which was not desirable, or the rolls would not be down sufficiently close to do any good at all. He thought it would be very much better to let the rolling-mill be a rolling-mill, and put down mangles quite independently. That raised a different question, as to the selling of flat plates. Mr. Lamberton spoke very highly of the quality of the finished surface of English-made plates as compared with those produced in America and on the Continent. He thought, although perhaps it might cost more to produce a plate with a highly finished surface, it was very desirable that one should not sit down to produce a plate finished in the way they were accustomed to see coming from American and the Continental mills. At the same time they produce a plate which was flat. Now if one went to buy a bar or a rail in England, one got a straight bar or a straight rail, but one ought to be able to get a flat plate as well. It ought to go through a process of mangling so as to provide a perfectly flat plate which was ready then for any constructional engineers to work into any shape they wanted. It was not the province of the constructional engineer to begin to straighten plates when he got them from the rolling-mills. He ought to receive them straight and flat, and he thought this proposal of Mr. Lamberton's would be better worked out by making the rolling-mill a rolling-mill and putting in the mangle quite independently. Mr. Lamberton also said, "The solution is to be found in the increased speed of driving, which enables plates to be rolled with such rapidity that the cooling effect produced by working the rolls wet is discounted by the heat generated by the work expended on the plate in reduced time." He did not quite know what Mr. Lamberton meant, but it looked as if he got heat put into the plate by the work done upon it in the rolling-mill. If that were so, the plate was being heated by very expensive means, because if one put heat into the plate by the excessive work done, that heat had to be obtained by work done in the engine, and he thought that was a very expensive way of heating the plate.

Mr. J. M. GLEDHILL, Member of Council, wished to compliment his colleague, Mr. Lamberton, on his paper on rolling-mill design. Personally his experience was that of producing plates on a large scale, but more in the direction of heavy plates, than of the ordinary commercial plates, and dealing with ingots of anything from 60 to 80 tons in weight for the production of armour-plates, and this design of mill had appealed to him very much as compared with a mill he was associated in the design of some seven years ago. He thought the arrangement of tandem housings was an excellent one, and if he had to reconstruct his mill he should certainly adopt this arrangement of having a roughing-mill and then the finishing rolls parallel. There was one point in the early part of Mr. Lamberton's paper in which he referred to the rapidity of rolling plates. That was desirable to a certain extent; but when one got to rolling plates beyond a certain thickness, he had found that, owing to the surface of the slabs getting worked at a higher rate than the

interior of the material, a varying action was obtained, and the plate obtained thought to be perfectly sound was really in the condition that the surface between the rolls had been drawn more rapidly than the interior, with the result that that part was hollow and not homogeneous. That was a point to watch in the speed over-rolling. The arrangement permitted one to use the rolling-mills at a slow rate, as Mr. Lamberton described, and then, should the plates have got thinner, to go at a much higher speed, and probably that would have some effect in overcoming the difficulty, although he thought if once this hollow condition was produced, even on thinner plates, one might not get as good a result as with slower rolling. It might be of interest to mention some of the points that they had had to deal with in the design of their mill. Probably the most important one was immunity from breakdowns. Although they had to produce a comparatively small weight per week, 200 to 300 tons of armour-plates, still the value ran to anything from £10,000 to £20,000, so that the stoppage and breakdown of a mill for two or three weeks meant a very great deal. Perhaps one of the most interesting things they had to think about was the question of the housings, because the breakdown of the housings meant a very considerable time for replacement. They decided first that their rolls should be 4 feet in diameter and 13 feet 6 inches on the face, made of nickel steel weighing something like 58 tons each roll. Then they thought about the housings, and that to make castings suitable for that size of roll was no small order, anyhow for Manchester. Probably other towns could make them without blowholes, specks, or blemishes. So they decided to have them made of forgings, and he would give them a very neat way of making housings from forged steel. First they cast rectangular ingots each weighing 80 tons. They then forged those ingots under a 12,000-ton press. Each of those forgings, finished, weighed about 52 tons, and they were bolted together in a special manner. The centre was cut out for the reception of the rolls. Those had been working now seven years, and they were just as they were, and he rather fancied they ever would be. Another point that gave them a great deal of food for thought was as to whether they should have compound engines or ordinary high-pressure engines, the latter being of the vertical marine type, with three cylinders, with a type of Joy valve worked hydraulically. Then they thought they might have the cylinders of their engine crack, so they made the cylinders of forged steel, which were also at the present moment just as good as they were put in; in fact they had had no breakdowns, and the mill had been working practically night and day for seven years. He again complimented his friend Mr. Lamberton on the excellent designs he had put before them, and he should like him, if he could, to give the meeting his views of the percentage of steam economy in the adoption of his compound engine for rolling-mill practice over ordinary high-pressure engines.

Mr. P. N. CUNNINGHAM, President of the West of Scotland

Iron and Steel Institute, complimented the author on the ability which he had shown in the compilation of his paper and the facts he had put before the meeting. In regard to the design of the mill, he personally thought that this was the manner in which plate-work would be done in the future. Whether the rolls would be 10 or 15 feet apart or 60 feet apart would be a matter of experience, but he was quite sure that twin rolls would come to the front. Mr. Lamberton had told them in his paper that the arrangement he had made with the hard rolls by increasing the speed was a very good one indeed, but he thought that up to the present time the reason that less power had been taken from the engine had been the question of the strength of the structure. If one undertook to work to the hard roll, the power to work the hard roll was gauged to suit the strength of the hard roll or the housing. He thought it could have been accomplished if they designed the mills strong enough to put as much work on the plates in the hard roll as the engines could develop in the soft roll, and in that way they would be improving the quality of the plate by driving the work right to the very centre, and in that way improving their extensions. In reference to Mr. Riley's remarks, he remembered very well indeed the pious horror of the engine-driver if one asked him to see if the machinery could be driven a little faster. He remembered also when he increased the speed at other works for which he was responsible he had the same difficulty to face there; everything had to be fought. In connection with the three-high mill they had a tremendous fight to get to what they did. Then they rolled plates up to 6 feet wide. When he was in America four years ago he came across a mill which had been built in recent years, and the designer and builder of that mill told him that he was the first to arrange the vertical roll upon the issuing side of the mill. It was a three-high mill, and the vertical rolls were in contact with the plate. So that in that way the vertical rolls of the mill were assumed to be running near the same periphery of the speed as the horizontal rolls. In a great many mills previous to that that had been the difficulty, that the vertical rolls had been kept in contact with the material on both sides of the rolls, and accordingly as the draught was greater or less so was the variation of the speed of the rolls. With regard to the plates that could be rolled in that mill, they were to-day rolling plates commercially 45 feet long and $\frac{3}{16}$ ths thick, and this was in a reversing-mill with two sets of rolls and escape-gear. He admitted that Mr. Lamberton had overcome the difficulty of time lost by skidding across; but he found in his practice that the work done was 37 per cent. by the hard roll, so that left 63 per cent. of the work done by the soft roll. With regard to the question Mr. Lamberton had raised as to rolling with both sets of rolls wet, he had carried out experiments in a small way, and he found that, generally speaking, plates rolled, both sets of rolls flooded with water, when placed in a pickling solution did not lose so much as the other by $1\frac{1}{2}$ per cent. He was referring to plates $\frac{5}{16}$ ths thick and under. They found that

by having them rolled by both sets of rolls flooded with water as against both sets of rolls perfectly dry, they had a saving in the pickling solution of $1\frac{1}{2}$ per cent. in favour of the plates rolled flooded with water. That was a point to which perhaps not much attention had been given, but it had simply cropped up in the usual course of business, and he thought he would try the experiment in a rough way. The experiment had been carried out about three or four weeks, and while the result was not such as he would base a definite conclusion upon, he was satisfied that with plates rolled with both sets of rolls flooded with water there was less proportion of oxide than there was in plates that were rolled perfectly dry.

Mr. HENRY CROWE (Middlesbrough) said that the author had insisted that the finish of the plate of the ordinary three-high mill could not be made as good as the two-high. He thought that could be got over quite easily by putting up two sets of three-high mills. The three-high mills in England generally had two sets of housings, so that the roughing down was done in soft rolls and the finishing in hard rolls. Therefore, as far as the question of surface was concerned, he did not think there was any difficulty in getting it in three-high mills. There was no doubt, too, that if the hard rolls and the soft rolls were driven by independent engines, the output of the mills would be greater than was possible by Mr. Lamberton's mill. It seemed to him that, for one engine, and for a given amount of capital expenditure, the greatest output would be got from Mr. Lamberton's design, and that certainly was a point in favour of it. He did not think that with one engine a mill could be designed to make a larger output than the mill Mr. Lamberton had installed at Coatbridge. In reading over the paper he thought there was some trouble in Mr. Lamberton's mill in the plates turning up. Sometimes the plates, when they were being rolled, if they were fairly thin, turned up at the end, and if so they would not pass through the rolls; but he found that Mr. Lamberton had provided for that difficulty, by making a series of hanging guides. Then, on looking at the drawing, the guides of the hard rollers were shown there in one piece, and that struck him, too, as being a thing to give some trouble. He thought the guides in the hard rolls should be made in several pieces so that they might lie very close against the rolls. He should like to ask Mr. Lamberton if he had any trouble with the guides of the hard rolls being made in one piece, as shown on the drawing. Mr. Lamberton also made a point of the time saved in skidding the plate from the hard to the soft as usual in two-high mills. It seemed that it must take some time, when one changed from the roughing roll to the finishing rolls, to screw down the finishing rolls, so that the time saved by that operation should be put against the time saved in skidding. With regard to the output of the mill, Mr. Lamberton had said that 130 tons of plates $\frac{3}{16}$ ths thick could be rolled in a shift in his mill. That was a very good output for any mill, he thought, whether for one engine or two, and certainly for one. But he also thought that the type of the mill

largely depended on the shape and size of the slab put in the mill as it came from the cogging-mill. In America they got their very large outputs by getting the slab from the cogging-mill in a shape that would here be called a roughed-down plate, and did not take so long to roll down as slabs did in this country. He would be glad if Mr. Lamberton would tell them the size of the slab he put into the mill to produce his 130-ton output. It also struck him that those standards would be better if they were farther apart. It was desirable that the roller should be able to get between the standards easily, and examine the guides. He quite understood if the housings were farther apart the gearing would be larger, but he did not know whether that would compensate for the advantage of getting between the rolls or not. Mr. Lamberton had evidently succeeded in making a reversing-mill engine, consisting of one low-pressure cylinder and one high-pressure cylinder, and he was to be congratulated on that point. All successful compound rolling-mill engines on the Continent had been carried out with four cylinders, two high and two low. In this case they had one high pressure and one low pressure, which was very much simpler. Also those members who were interested in electrically driven engines would find Mr. Lamberton had brought out a mill which was eminently suitable for motor driving, because with very large powers it was usual to split the motors into two powers, one armature being generally too large for the power. Here a very good combination indeed for electric driving was provided by two armatures coupled respectively to the hard and soft rolls direct. The question of straightening the plates had also been discussed. He did not see how the plates were mangled very much; but if the soft rolls were run at a slower speed than the hard rolls, there was a slight stretching action going on, and that would straighten them very effectively. In fact in Germany there was a straightening machine which did this by pulling the ends of the plate, and so straightened them.

Mr. E. J. DUFF (Liverpool) said that Mr. Riley had been good enough to mention his name in connection with a three-high mill erected at Blochairn about the year 1890. He had not had the advantage of reading Mr. Lamberton's paper in advance, so that he would confine himself to one or two remarks in regard to the three-high mill. The plates rolled in the mill at Blochairn measured up to 5 feet 6 inches wide, and they were successful in getting both a large output and a good finish. However, there were defects in the mill, as Mr. Riley had acknowledged, due chiefly to their having followed too closely the American designs in regard to the tables, &c., and these gave trouble, and frequent breakdowns and stoppages of the mill occurred. He thought, however, that if Mr. Riley's directors had had the nerve to spend the money in eliminating these defects, and had gone on with the principle of three-high rolling, they would have made a success of it. He, however, quite appreciated the good points of Mr. Lamberton's mill.

Mr. LAMBERTON, in reply, said that Mr. Riley referred to the engine, and expressed a fear that the type of engine used in this mill might have some complications. He could reassure Mr. Riley that there were really none. It was an extremely simple engine indeed. He had succeeded, as Mr. Crowe had pointed out, in having a compound two-cylinder reversing-engine to work with as great rapidity in reversing as with the double compound tandem type. There was a difficulty about it, and, indeed, he did not at first see how he was going to manage it, but he thought it could be done, and he did manage it. They had only two cylinders as against four, and had all the advantages in steam economy that could be had in the double compound tandem, with a very great deal less complication. When they had to draw a piston it was an easy matter. The double compound engine was notoriously a difficult engine to overhaul. So that in that respect he was glad to say to Mr. Riley that there was no complication. If it was the point of the double handling valves, that was a very simple matter. They were simply connected by rods to one handling lever, and when one shut down the admission valve of the high pressure and also the admission valve of the low pressure it acted as a very effective brake for bringing the engine to rest. Mr. Riley had spoken of plates being rolled 80 feet long, and he hoped that in his mill they would roll plates of the ordinary girder type 100 feet long. Mr. Harrison spoke of the straightening action. They had a little of that; but he thought it was that the plate was prevented from wobbling as it went through, and the straightening action was helped in that way. He agreed with Mr. Harrison's remark that all commercially sold plates should be straight, and that the proper way to accomplish that was, whether one used the straightening power of a mill like this or not, to have them mangled before delivery. That was done in Messrs. Colville's works in nearly every plate they turned out, and by many other makers too. Mr. Harrison spoke about the heating of a plate due to the speed of rolling. He did not mean that they tried to heat plates by driving at high speed; but they wanted to drive them as fast as they could, and there was heat generated that prevented the piece cooling as rapidly as if it went through slowly. One could roll down plates to a thin gauge with that assistance in a way that could not be obtained otherwise. Mr. Gledhill spoke about the speed of rolling, and referred to something in the way of a defect being produced in a thick slab if the rolling was done too fast. He presumed he was speaking about armour-plates. He (Mr. Lamberton) could quite understand if one put too much work on the surface of a thick slab it would probably open up in the centre. But practically nothing of that kind happened in rolling plates. The passes were of light draught, and they were taken fast, and the character of the plate all through was excellent. He might say that the tests they had got from the plates rolled by that mill were excellent in that way. Mr. Gledhill spoke of a way to make housings. He (Mr. Lamberton) was afraid that he could not get the price for housings if he made them like that. There was a fortune in these

housings, and he had to work for a great deal less money. He thought Mr. Gledhill at the finish of his remarks made some statement to the effect that he congratulated him on using a compound engine. He did not claim that at all. Compound engines had been used in reversing-mills now for quite a number of years, and very successfully. However, he thought he was the first who had used a compound engine of the single type, one cylinder high pressure and one cylinder low pressure, and they had accomplished the reversing, which, as he said, was the difficulty, in a first-class way. Mr. Cunningham spoke about the amount of power relatively used in soft and hard rolls. Diagrams were submitted which represented average powers taken from an ordinary high-pressure side-by-side reversing-engine, when rolling in the soft rolls and in the hard rolls, those were average diagrams taken from the number of passes in each. In the first roll, according to the diagram, the indicated horse-power was 3425 in the soft roll, and only 2210 in the hard roll, showing he had a very largely increased power at his disposal, and he utilised that in increasing the speed of the finishing rolls. He thought he was right to equalise the power being used in both sets of rolls, as nearly as possible making them identical, because he claimed that was the proper way to work plate-rolls. Reference was made by Mr. Cunningham to working the rolls wet, and he was glad to have his support in that way, because it did seem very clear that if rolls were always worked wet their lives would be enormously extended and their surfaces preserved for a much longer time. Their necks would be prevented from heating and cutting, and there would be a saving in lubricants, saving in rolls, saving in everything; and when all that was accompanied by a distinct increase in the quality of the plate produced, they must really get to working rolls wet without any further delay. Mr. Crowe referred to the three-high mill, and said that his (Mr. Lamberton's) remarks in regard to the difficulty in keeping the surface finished up could be met by putting in two sets of three-high mills. But he was not designing two mills, he was designing one mill, and it was obvious if one could give a man twice the money he would probably produce a larger output. But he was face to face with being asked to design a mill which would give the largest output for the smallest expenditure, and he tried his best to do that. But even with two sets of three-high mills, there would be far more changing of rolls necessary to keep the surfaces up than there would be in his mill. Mr. Crowe referred to the liability of a plate to turn up at the point. The diagram on the wall showed a device he had designed to prevent that, and the little hinged guides were weighted behind so that they were always kept in touch. They found them very efficient, and they had never had any trouble from them. Mr. Crowe spoke of the time saved by this mill in skidding across; that it probably was discounted by the time taken up in putting the hard rolls down and easing off the soft rolls. As a matter of fact, in the working of the mill the process was going on simultaneously; when they began with a slab, say, 4 inches thick, from the

roughing rolls, as soon as it got reduced to $\frac{1}{2}$ inch the driving of the screw gear followed down with the hard rolls, just keeping a little bit behind. There was not any time lost there, and the thing worked very nicely. Mr. Crowe asked about the size of slabs for an output of 130 tons of $\frac{3}{16}$ ths plates. They ran about 4 to $4\frac{1}{2}$ inches, and weighed 15 cwts. Then he asked whether it would be better to have the housings farther apart, and he thought he answered himself pretty well there by saying he thought the complication would be somewhat great in the gearing, and they did not think there would be any great advantage in increasing that. Then he spoke of electric driving. He (Mr. Lamberton) thought the design might be said to lend itself to electric driving, and there again it was a question of price. With regard to the question of output, the whole crux of the question was this: Could one feed an ordinary plate-mill any faster than a slab every two minutes; had they got facilities; had they got heating power; had they got handling power to keep a mill fed with a slab every two minutes all the day through, and take it away when they had rolled it? He had not seen the works in this country that could keep up that speed of feed. Therefore, if this machine had reached the speed of being able to deal with a slab every two minutes, and it could not be fed at that pace, he thought they did not want it any faster at present; they had reached the limit of their feed. Therefore it seemed to him, all these questions of double output were beside the mark. What was wanted now was to increase the facilities for heating and feeding the slabs to the mill, and then after that, if a man said to him he wanted to get 100 tons more per shift, he would see what he could do for him.

The PRESIDENT said that there would be no mere formality in the vote of thanks he was going to ask the meeting to accord to Mr. Lamberton for his paper. Not only was the paper itself a very considerable addition to the papers already in the possession of the Institute, but the discussion on the paper might almost be taken as a model of what the discussion on those papers should be. Members had stuck to the period of time that was allotted to them, and, what was more, they had stuck so closely to the matter in hand, that he had not the heart, when a man transgressed by a minute or two, to call him to order. He congratulated the Institute on the discussion which had followed upon Mr. Lamberton's paper. He should have liked, if time had permitted him, to have said a word or two upon the paper himself, but he would add nothing to the discussion beyond congratulating Mr. Gledhill upon having demonstrated once again from Manchester the existence of that pride which apes humility, and recalling to their recollection the modest way in which Mr. Gledhill intimated the impossibility of Manchester producing a casting sufficient for the purpose in question, and then proceeding to say, as though he were handling an ounce weight, how he merely made a couple of forgings of 80 tons, and proceeded to do so and so. He

asked the meeting to accord by acclamation their thanks to Mr. Lamberton for the most excellent paper which he had contributed.

The resolution was carried by acclamation.

CORRESPONDENCE.

Mr. F. FINLAYSON (Airdrie) wrote that Mr. Lamberton claimed that arranging the roughing and finishing rolls tandem about $7\frac{1}{2}$ feet apart was an improvement on the general practice. He (Mr. Finlayson) considered that would make it rather dangerous in practical working, as it was well known to plate-mill managers that occasionally a slab or plate had a tendency to run into the neck, and when the piece was longer than 7 feet 6 inches it would be apt to strike the opposite housing and thereby cause damage. As Mr. Lamberton stated, it did away with a set of tables, *i.e.* if there were fixed tables and skid gear, but where travelling tables were used it did away with nothing. There were mills working at the present day which had been at work for the last sixteen or eighteen years with travelling tables. The mill at Stockton—made by Miller & Co. to the writer's design—was still at work so far as he was aware, and the average output was 1450 tons per week. Mr. Lamberton stated that there was not the same reduction required in the finishing rolls of his mill as there was when the plate had to be transferred across. He (Mr. Finlayson) failed to see how this could be so, any more than in the ordinary transfer mill. His own practice in plate-rolling had invariably been to bring the plate down as near the thickness as possible in the grain rolls, and to finish with as few passes as possible in the finishing rolls. He did not think it was anything new to do 80 per cent. of the work in the grain rolls—in fact he would be inclined to pull the plate down less than that, as from four to six passes in the finishing rolls were ample to put a good finish on the plate. Regarding the hard rolls remaining for a longer time in good condition in the new mill, he failed to see how this could be, as he had run a pair of hard rolls for over a year without dressing. Of course those rolls were run cool, *i.e.* there was a continuous spray of water playing on them, and they were never allowed to get above blood-heat.

It was well known in plate-rolling that the first two passes in the hard rolls took up the full power of the engines, while in the other passes the steam was wire-drawn through the top valve, which was certainly not economical. The author's idea of equalising the load upon the engines might be a success, but he (the writer) was of opinion that the present mode of rolling was simpler. He did not think there was much to condemn in the ordinary method of transmitting the power through the bottom roll if the necks and wobblers were properly designed.

1908.—i.

D

The author stated that in high-speed mills there was a tendency to turn out wavy or buckled plates. That was caused by careless rolling, and suggested that during the final pass through finishing rolls the roughing rolls were also put down to come into light contact with the plate. That was practically making the mill into a double-drafted mill. Seeing that the two pairs of rolls were not running at the same speed, the hard rolls would have a tendency to draw the plate. That would very likely cause trouble in keeping the pinions in order, and might lead to the pinions or the pinion housings being smashed. As he (the writer) had had some little experience with a double-drafted mill in rolling rails, and had plenty of trouble with it, he wondered what the result would be when rolling plates?

To sum up, if the author wished to introduce a tandem mill, he was of opinion that the better way to do so would be to drive the roughing and finishing rolls separately, placing the former about 100 feet in advance, and to drive the mill by two separate engines. He thought Mr. Lamberton deserved credit for his boldness in making a new departure, but he did not think he had gone far enough.

Mr. O. C. MORGAN (Rotherham) wrote that the waving of plates was not caused in any great degree by the actual higher speed of more modern mills. Apart from the fact that the roller could not, in cold finishing rolls, which were necessary in order to obtain a large output, remedy the hollowness caused by the greater wear of the middle portion of the roll, the straightness of the finished plate largely depended on the skill with which the roller drafted the plate during the last few passes in finishing down to specified thickness; also to the care he took during those last few passes, in keeping the plate in the same sweep or portion of the width of the roll. The latter more especially applied, the more hollow the rolls become through wear. Undoubtedly the best thing was to have a straightening machine apart from the mill, and he agreed with Mr. Harrison, that the author would not get any better straightening effect than in an ordinary mill, unless there was a slight stretching produced by the different speed at which the two sets of rolls revolved. With respect to the finish of plates rolled in cold roughing as compared with those rolled in hot roughing rolls, the writer was desirous of knowing in what particular respect the finish of the plates rolled in cold roughing rolls was better, as if the plate was properly scaled in the roughing rolls the whole of the finish was apparently produced by the finishing rolls. He had not found the finish to be any better, and though there might be a little more wear on the necks and brasses, it was very little, and not anything like commensurate with the fact that water-cooled rolls required much more frequent turning, from the effect on the surfaces produced by the heat and water combined.

Mr. F. W. PAUL (Harrogate) wrote that reference had been made to a three-high plate-mill, and it was claimed that, apart from the weak constructional design of the live roller tables, the work

accomplished by that mill covered in most respects the advantages set out by Mr. Lamberton for his new design of tandem plate-mill.

The three-high plate-mill referred to commenced to work in 1888, and was in existence practically for six years. During that period, the largest four weeks' output did not exceed a total of 1183 tons, and the total for any year was less than 3000 tons per annum. He (Mr. Paul) having had experience of that mill in 1894, desired to point out (apart from any considerations as to the merits of three-high system as applied to plate-rolling), that the usual method of driving large three-high plate-mills in America, and on the Continent, was by direct drive with heavy fly-wheel in line, whereas the three-high mill referred to, with 8 feet 6 inches rolls and periphery speed of about 500 feet per minute, was driven by intervention of gearing, and counter-shaft, with a fly-wheel on the engine shaft. That arrangement, with its objectionable accompaniment of increased back lash, resulted in considerable shock when the slab or plate entered the rolls, and consequently the mill was finally abandoned by reason of the frequent breakages of the gearing.

Referring to the last paragraph but one of the paper, the author said "the solution of working the soft rolls wet is found in increased speed of driving." If the mill were kept fairly busy, with 80 per cent. of the work done in the soft rolls, it would be necessary to have a very copious supply of water running on the rolls to insure keeping them wet, otherwise any half-way measure of turning the water off whilst rolling, and subsequent cooling, resulted in rolls breaking. Members were familiar with the halting conditions in reversing-mills, which frequently took place in the roughing rolls of rail, section, and cogging mills when the draught on the bloom or slab was heavy, but such halting in the case of a reversing plate-mill with wet rolls would be disastrous. In continuous running plate-mills, either two- or three-high, arranged with heavy fly-wheel and direct drive, the full speed could be maintained with minimum of back lash, and the halting completely guarded against, whereas, in the case of the author's mill, driven with a compound condensing reversing engine, it would be necessary the full power of the engine should be on the moment the mill bites the slab, otherwise the ends of slab would get chilled, thus enormously increasing the strain in a fast-running plate-mill, and would be apt to conduce to breakages. Speaking generally, he deprecated the intervention of gearing in the design of a modern fast-running plate-mill; and as the splayed ends of thin plates necessitated careful adjustment of the guards, the close juxtaposition of the housings of hard and soft rolls was objectionable. Criticism was, after all, only a surmise of what might occur, and the performance of the mill in extended practice should be the best answer; and he (Mr. Paul) desired to express the hope that the apprehensions held respecting its performances would be found in actual working to be groundless.

Mr. ANDREW LAMBERTON wrote, in reply to Mr. F. Finlayson, that

no trouble had been experienced in regard to the plate running into the neck or colliding with the housing in its passage through, and that as to his remark about travelling tables, he considered they were now obsolete, and that any one proposing to adopt them at the present in a new mill would be regarded as making a very retrograde step. In the ordinary type of mill it had been found much better to have four fixed tables and skid-across gear, and all modern plate-mills of that type had that arrangement. The author's design of mill had now rendered more than 50 per cent. of the accessory machinery unnecessary, and had greatly simplified the operations, with a consequent increase in output. With travelling tables, as suggested by Mr. Finlayson, a plate could not conveniently be transferred which was more than 30 or 40 feet long at the very utmost, and as there was no reason why girder plates should not be rolled up to 100 feet long, it was obvious that in the old type of mill a much larger proportion of the reduction necessarily must be done in the finishing mill, and that was where a great improvement was claimed for the new type, as the roughing-down could be carried out on such a plate of 80 or 90 feet long, and then four passes in the hard rolls would finish it. Mr. Finlayson spoke about the straightening of the plates during the final pass, and of the new mill as being equal to a "double-drafted mill" during that pass. That was not so; the only rolls in actual contact at the time were the hard ones, the soft rolls merely touching the plate, and that steadying of the tail of the plate tended to straighten. Mr. Finlayson thought that the roughing and finishing mills should be set 100 feet apart. That suggestion was also made by Mr. Henry Crowe, but that would really mean the installation of two mills with two engines, whereas the mill as designed by the author was capable of giving a very large output for the minimum of initial expenditure, and few works in Great Britain required more than 400 tons of such plates per turn.

He quite concurred in Mr. O. C. Morgan's view, and also in that of Mr. Harrison, that plates should be finally mangled before leaving the works; but would point out that that method of delivering from the rolling-mill enabled straighter plates to be got than from the ordinary type of mill, and it was all in the way of progress that such plates should be obtained. With regard to the question of the superior finish of plates which had been rolled with both sets of rolls drenched, the explanation was that the scale was more thoroughly shed when water was used freely, and the final finish of the plate was improved in quality and surface finish. There was in addition to that the advantage in saving the necks and brasses, and extending the life of the rolls themselves.

Judging from what Mr. F. W. Paul had written in regard to the three-high plate-mill referred to by Mr. Riley and Mr. Duff, it did not seem to have been successful, the total output during its six years' existence having been exceedingly small. With regard to working all the rolls wet, and the difficulty Mr. Paul anticipated owing to the "halting" in reversing-mills, it was difficult to see where

there could be any serious trouble in that way, as it was the present universal practice to work the hard rolls of reversing-mills drenched, and they had the same halting action as he spoke of, and yet no trouble had been experienced. Mr. Paul concluded by remarking that practice was the best test for meeting difficulties that might be apprehended, and he (Mr. Lambertson) had pleasure in saying that, so far, none of the anticipated troubles referred to had been experienced in practice, nor were there any indications that they would be.

Mr. JAMES RILEY, Vice-President, having taken the chair, called upon Dr. T. E. Stanton to read his paper.

A NEW FATIGUE TEST FOR IRON AND STEEL.

BY T. E. STANTON, D.Sc., M.Inst.C.E.
(COMMUNICATED FROM THE NATIONAL PHYSICAL LABORATORY.)

IN a recent investigation of the properties of certain samples of steel rails made at the National Physical Laboratory (for the Great Northern Railway Company), a statement of the mechanical tests, to which it was considered advisable that specimens cut therefrom should be subjected, was drawn up by the author. In this were included, hardness, impact, and abrasion tests, the tensile and drop tests having been already made.

Although this seemed all that was possible to be done, yet, from a study of Mr. Kirkaldy's paper at the Institution of Civil Engineers in 1899,* in which the failure of steel rails was traced to the development of cracks in the upper worn surface, brought about by repeated bending, the author felt strongly that a test which would give a combination of rolling abrasion and alternate bending would be invaluable.

It has since occurred to the author that this combined action could be produced and utilised as a laboratory test in the manner indicated in Fig. 1.

R is a hollow ring of rectangular section cut from the steel rail to be tested, and placed between three hardened steel rollers symmetrically placed as shown.

If the upper roller is loaded with a weight, W , the ring will be in equilibrium under three equal forces, W , at the lines of contact, and by rotating the upper roller motion will be communicated to the lower ones by the rolling friction of the ring. In this way the outer surface of the ring will be subject to rolling abrasion, and every radial section of the ring will be subject to alternate bending stresses which will go through a complete cycle three times in one revolu-

* "The Effect of Wear upon Steel Rails," *Minutes of Proceedings of the Institution of Civil Engineers*, vol. cxxvi. p. 141.

tion, and the magnitude of which can be calculated from the dimensions and the load.

The advantages of such a test were so obvious that a simple machine on these lines was constructed, and was found to work satisfactorily, with the exception that the load on the upper roller could not be made considerable, owing to the resistance of the bearings of the lower rollers, which soon became greater than the frictional resistance at the line of contact with the specimen. The result was that when this limiting load

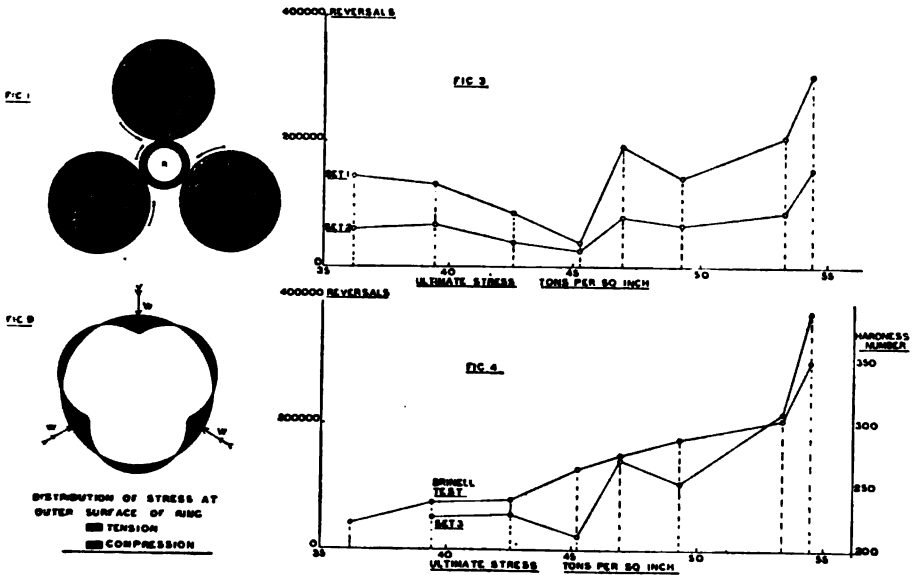

was reached, the specimen ceased to rotate, and a flat was at once worn on its surface by the upper roller, rendering it useless for further testing.

A new machine was therefore designed and constructed, and is shown in Fig. 2. In this the axles of the lower rollers are supported on the rims of friction wheels, an arrangement which proved quite satisfactory, the specimen rotating uniformly up to the highest loads used until fracture occurred.

The rollers and their axles are made of tool steel hardened and ground to the same diameter. The upper roller revolves

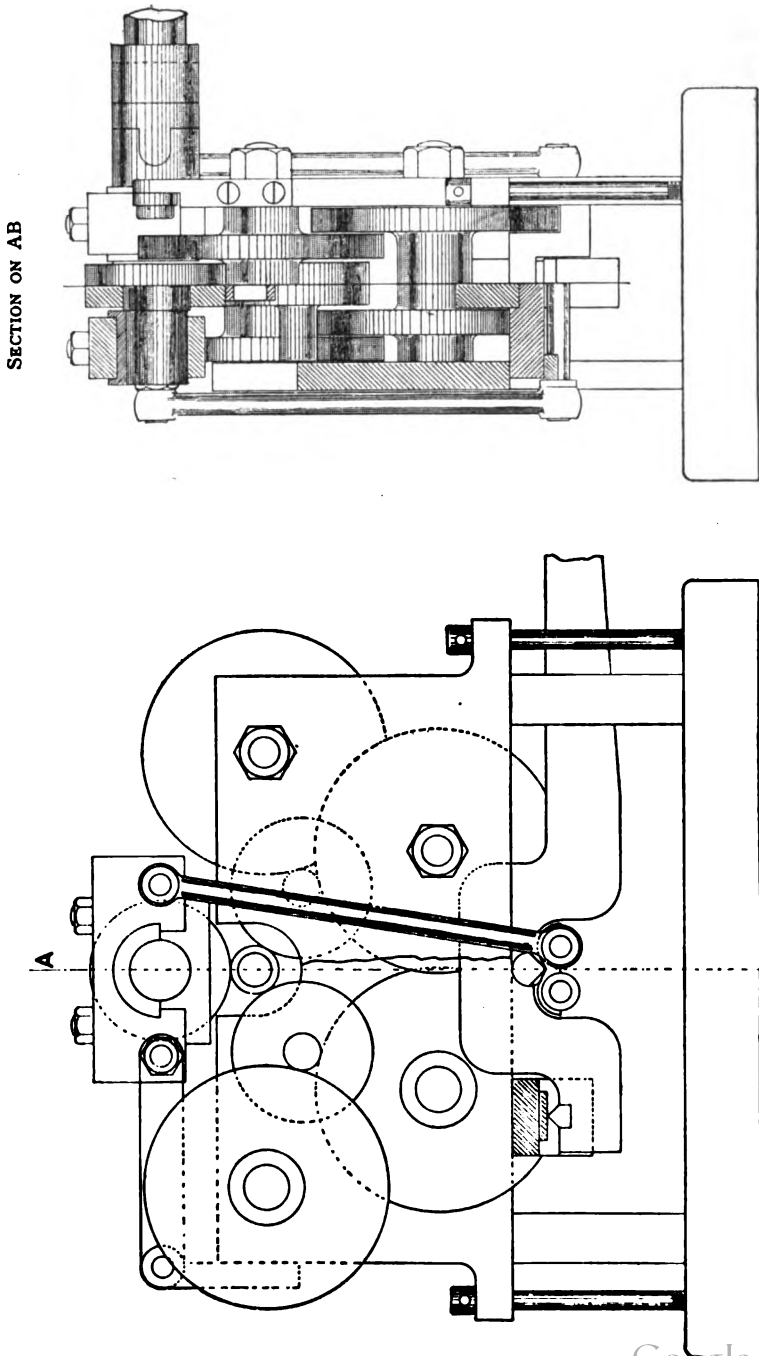

FIG. 2.—Fatigue Testing Machine.

in a double brass bearing, which is hinged to the side plates of the machine, and motion is communicated to it from a shaft parallel to its axis through an Oldham coupling, which allows the roller to sink without constraint as the specimen wears away. The load is applied by a weighted lever, whose knife-edge rests on a saddle supported from the bearings of the upper roller by the side rods shown in Fig. 2.

The behaviour of a specimen under test consists of a wearing down, and spreading over the edges, of the outer surface to an extent depending upon the hardness of the material. After some thousands of rotations the surface begins to slightly disintegrate and falls off in thin flakes. As the test proceeds,

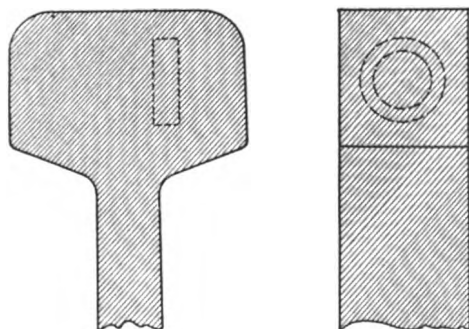

FIG. 5.—Position of Specimen in Rail Head.

after a time, depending, of course, upon the load, small cracks running parallel to the axis begin to appear on the inside or outside surfaces or both. These develop until the specimen is no longer able to sustain the load, and fracture occurs. A photograph of a specimen after fracture is shown in Fig. 6, from which will be seen the characteristic zigzag fracture in these tests. On examining the surface of a specimen after fracture it will be generally found that there are innumerable small cracks running across the surface parallel to the axis which are, in their initial stages, only visible in the microscope. Photomicrographs, Figs. 7 and 8, show the polished and etched surfaces of two specimens after testing, Fig. 7 being from No. 8 rail containing 0.43 per cent. of carbon, and Fig. 8 from No. 1

rail containing 0·39 per cent. of carbon and 3·32 per cent. of nickel.

Materials on which Fatigue Tests have been made.—All the tests described in this paper have been made on specimens cut from sample rails supplied by the Great Northern Railway Company, and the author is indebted to Mr. Alexander Ross, M.Inst.C.E.,

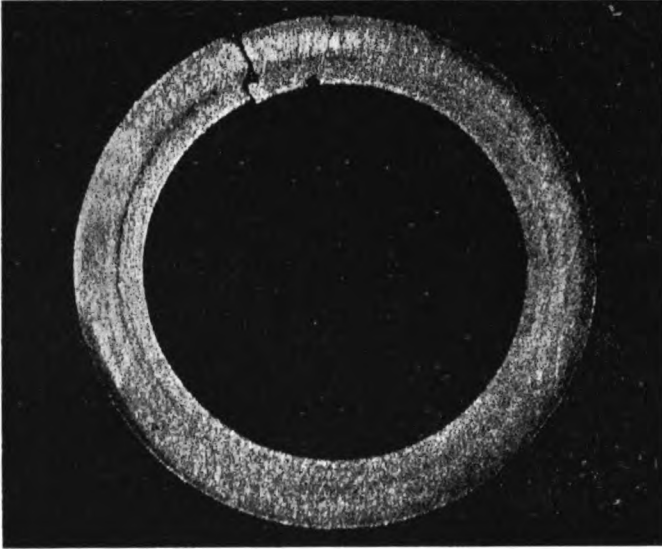

FIG. 6.—Photograph of Ring after Fracture.

for permission to give the following details of the respective rails:—

No. of Sample.	Weight per Yard.	Service.	Date of Manufacture.
1	85	18 months.	1904
4	85	17 months.	1903
5	85	New	1905
8	100	New	1905
10	...	New	...
11	80	35 years	1870
913	...	New	1907
13	96	5 years	1902

Chemical Composition.

No. of Sample.	Carbon.	Manganese.	Silicon.	Phosphorus.	Sulphur.	Nickel.	Chromium.	Cobalt.
	Per cent.	Per cent.	Per cent.	Per cent.	Per cent.	Per cent.	Per cent.	Per cent.
1	0·39	0·85	0·075	0·097	0·047	3·32
4	0·39	0·83	0·025	0·063	0·044
5	0·42	0·68	0·059	0·062	0·047
8	0·42	0·79	0·441	0·062	0·059
10	0·53	0·70	0·23	0·04
11	0·27	0·36	0·09	0·106	0·035
913	0·48	0·78	0·02	0·021	0·060	1·45	0·26	0·25
13	0·46	0·74	0·059	0·064	0·090

Results of Mechanical Tests made on Specimens cut from the Samples at the National Physical Laboratory.

No. of Sample.	Ultimate Stress, Tons per square inch.	Elongation on 2 inches.	Hardness Number from Brinell Test.
		Per Cent.	
1	54·6	11·0	351
4	42·6	26·5	240
5	39·4	27·5	238
8	46·9	23·0	276
10	49·3	21·0	288
11	36·2	26·5	221
913	53·4	18·2	304
13	45·2	19·2	265

RESULTS OF EXPERIMENTS.

Three sets of fatigue tests were made on rings cut from the sample rails described above, and from the centre of the rail-head as shown in Fig. 5 (p. 57):—

Set.	Dimensions.			Load in Pounds.
	External Diameter.	Internal Diameter.	Thickness.	
	Inch.	Inch.	Inch.	
I. . .	1·00	0·725	0·25	600
II. . .	1·00	0·725	0·25	675
III. . .	1·00	0·687	0·25	825

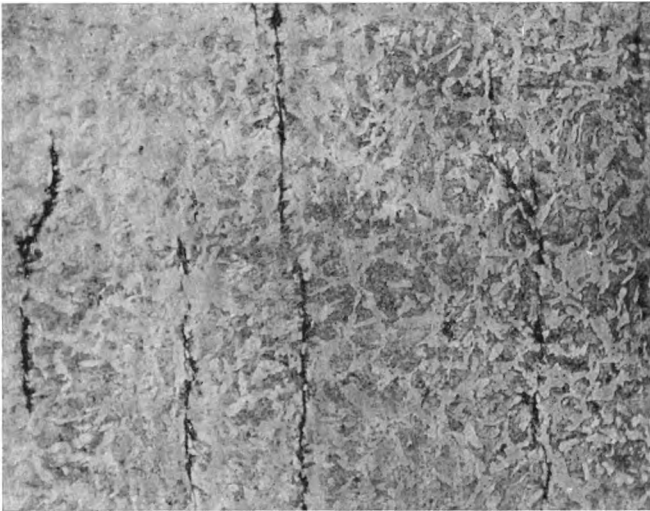

FIG. 7.—Rail No. 8. Photomicrograph of Cracks in Outer Surfaces of Specimens. Magnified 75 diameters.

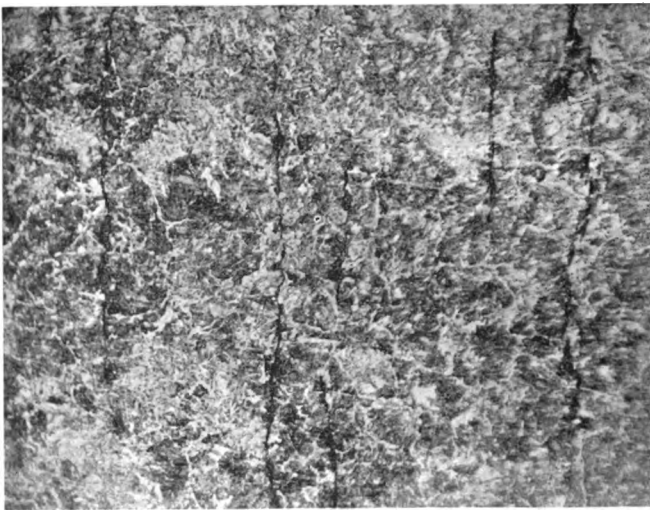

FIG. 8.—Rail No. 1. Photomicrograph of Cracks in Outer Surfaces of Specimens. Magnified 75 diameters.

With reference to the values of the stresses produced on the ring under the action of the load, the author is indebted to his colleague, Dr. Chree, F.R.S., for a solution of this particular case from the general equations given by Todhunter and Pearson.* The general distribution of stress at the outer radius of the ring is shown in Fig. 9 (p. 55), in which tensile stresses are plotted radially outwards from the circumference of the circle and compressive stresses inwards.

The following table gives the results of the experiments:—

No. of Sample.	Number of Reversals of Stress up to Fracture.		
	Set I.	Set II.	Set III.
1	306,000	155,000	372,000
4	86,000	39,000	55,000
5	131,000	66,400	51,000
8	192,000	79,000	150,000
10	142,000	87,000	106,000
11	146,000	59,200	...
913	206,500	84,800	215,000
13	38,000	25,600	25,000

The calculated ranges of stress from tension to compression at the outer radius were:—

	Range of Stress in Tons per Square Inch.
Set I.	35.6
Set II.	40.0
Set III.	36.7

The calculated stresses at the inner radius were about 15 per cent. greater than the above, but it is noteworthy that the cracks which ultimately caused the failure of the ring appeared to originate on the outer surface of the ring in the case of the hard steels, and on the inner surface in the case of the softer steels. This is probably due to the greater spreading of the material sideways in the softer rings, due to the rolling abrasion.

The results of the experiments given in the table have also been plotted on a base of ultimate stress in Figs. 3 and 4 (p. 55), and in Fig. 4 the calculated hardness numbers from the Brinell test have been plotted.

* "History of Elasticity," vol. ii.

It will be seen from the plotted results that although, broadly, a high value of the hardness number corresponds to long endurance to alternating stresses and abrasion, yet in several cases an increase in the hardness number is accompanied by a diminution of endurance. Thus in the case of rails 8 and 10, to which particular attention has been paid by repeating the experiments, in all three sets of conditions of test the harder rail No. 10 has distinctly less endurance than No. 8.

Another feature of the tests is the greater endurance of the two samples of least tensile resistance and greatest ductility, Nos. 11 and 5, relatively to the two stronger samples, Nos. 4 and 13. This is probably also due to the spreading and hardening of the material at the outer surface of the soft steels. A similar effect to this in practice has been observed, in which it was found that the loss of weight for the first 30,000 trains was 28 per cent. greater for the soft than for the hard rails, but that the wear due to the next 65,000 trains was 9 per cent. greater for the hard than for the soft rails.*

Further, the tests demonstrate the marked superiority of the two nickel-steel rails both as regards resistance to rolling abrasion and resistance to alternate bending.

Although the tests described above have been made at a moderate rate of reversals, 800 per minute, the testing machine is particularly suited for the purposes of high-speed fatigue testing, and it is hoped to obtain from it alternations of stress up to 4000 or 5000 per minute. For constructional materials the abrasion effect will be made small by reducing the thickness of the ring until the action is practically alternate bending alone.

* J. W. Post, *Organ für die Fortschritte des Eisenbahnwesens*, 1899, p. 268.

DISCUSSION.

Mr. J. M. GLEDHILL, Member of Council, said that rails were not quite in his line, but it seemed to him to be a very instructive essay, especially the part of it that appealed to him very strongly, namely that the tests proved so very much the superiority of nickel steel. He thought that was an extremely important result of such a test as that which had been described, which was a very practical test. It would have been rather instructive had Dr. Stanton put the limits of elasticity in the mechanical tests, and they would have seen a remarkable difference in the elastic limit as compared with the ordinary ones. It also struck him that it might be of great interest, if it had not already been done, to take rings for tests, in a similar manner, for comparison, and transversely. The rings shown were what he should call for a longitudinal test, and after all the rail was at a considerable test transversely. If that had not been done, he thought it would be very interesting to know some further details of transverse ring tests. Again, he considered that some rings taken from the top of the rail and outside would give a very interesting comparison. He did not think he could add anything further, except that the machine seemed very ingenious and a very practical way of getting at good results.

Mr. R. A. HADFIELD, Past-President, felt sure the members were very much indebted to Dr. Stanton for the new type of test he had submitted. He thought an original method of test nowadays betokened research work of a very high order. They owed their very hearty thanks to Dr. Stanton and their admiration for this new way of testing steel, especially for rail purposes. He would ask Dr. Stanton whether he had any tests from the rails themselves. He remembered reading some time ago about tests of nickel steel rails in America, but he thought the results were not found to be quite up to expectation. He did not remember the particular analysis, but he believed the steel in question contained about 3 per cent. of nickel. Of course the durability of such a steel would naturally also depend upon its carbon percentage. Many people in the outside world imagined that because a steel was nickel steel it was of a very high quality, but of course that naturally depended on the accompanying percentage of carbon and manganese. In other words, one might have a low carbon nickel steel which would not wear well, and that would not at all indicate that the nickel steel was not of very high quality with a proper percentage of carbon. He would ask Dr. Stanton, if he had any nickel steel of the type he referred to, whether he could give them any information on that point. As regards the ingenious way in which the apparatus was arranged, he would like to have some idea, if it were possible, of what was the total stress produced on these small specimens. He was not sure whether it was not already given in the paper. That was rather an interesting point.

Again he wished to say how very much indebted he personally felt to Dr. Stanton for this paper, because it happened to be quite a new matter of research on a very important class of steel that was now made—that was rail steel. When he went to America last year there was almost consternation over there with the results being obtained from certain rails. He did not think that indicated any inferior quality in the American product, but they were increasing the speed and size of the engines and trains, and therefore any apparatus which Dr. Stanton had put before them, which would enable a maker before he sent out his rail to know it was a safe rail or not, he was quite sure would be very highly welcomed, and that no one would offer more thanks to Dr. Stanton for his very interesting paper than Americans.

Mr. A. WINDSOR RICHARDS (Middlesbrough) said he was glad that Dr. Stanton was working in the right direction in trying to design a machine which would give a test showing what would actually correspond to what occurred on a rail under traffic, but he was afraid that his paper did not quite give them the information. The results could not be comparable, because the hard and soft rails, as was pointed out by Dr. Stanton, had been tested in different circumstances. The hard ones had been cracked on the outside edges, and the soft ones on the centre of the surfaces. That must of necessity give different results. Then rail No. 11 was bad from many modern points of view. The analysis indicated a very soft rail, with high phosphorus. The physical tests confirmed that fact, and it did not come out of the reversal of stresses very well. What was the actual result? The rail had stood in the road for thirty-five years! His point, therefore, was, that had that rail been made to-day, and been subjected to the combined tests shown by the author, there would have been very little chance of any engineer accepting it, or of its being put into the road at all. He had made several investigations on steel rails which had been in the main line for twenty-five to thirty-five years, and he had invariably found them to be high either in phosphorus or sulphur, or both, and when taken out of the track they had shown very little sign of wear, and had lost only about 5 per cent. of their original area. These rails, however, when subjected to the reversal of stress, quickly broke down. He very rarely found a breakdown in rails which were high in phosphorus and sulphur, unless accompanied by a flaw. Time only could tell whether rails of modern manufacture, which were very pure as regards those two elements, would last as long as the older manufacture, and give a greater margin of safety. He thought Dr. Stanton had been unfortunate in his selection of his test-piece. He had chosen it from that part of the rail which was mostly segregated, and the weakest part of the rail. It would be very interesting and much more instructive if Dr. Stanton could cut a thin layer of steel just underneath the running surface, because, after all, it was the head of a rail which came into actual use. He thought he recognised one of these rails

made by a process which he described before the Institute in a paper in May 1907. That was No. 913, which contained a mixture of nickel, chromium, and cobalt. Those rails, when tested in the Stead-Richards vibratory machine, stood three times more reversals than ordinary carbon rails. He thought it would be interesting if Dr. Stanton would supply samples from the rails he had tested so that results could be compared from their machine.

Mr. E. H. SANITER (Rotherham) wrote that he had heard with interest of Dr. Stanton's attempt to devise a combined alternating and abrasion test for rail steel, and must compliment him on his ingenuity. The first point which struck him was the direction in which the ring was cut from the rail head, *i.e.* in the longitudinal direction. As a consequence, roughly speaking, two sides of the ring would have the sides of the rolling fibres exposed, while the other two sides would have the ends of the rolling fibres exposed. The weakest part of the ring would be the sides where the ends of the fibres were exposed, and the ring would break there and in the longitudinal direction along the fibre.

That irregularity in the structure of the ring might be corrected by taking it in a transverse direction, when the sides of the rolling fibres would be exposed all round, but on breaking it also would break along the fibre in the longitudinal direction of the rail. In either of the methods of taking the ring, or any other possible one, the ring would break along the fibre in the longitudinal direction of the rail, while in practice the rail would break transversely, or at right angles to the fibre. It would therefore appear that the test was not suitable for the purpose for which it was devised.

With such a test it would be expected that a high sulphur rail, owing to the threads of sulphide of manganese rendering it weak along the fibre, would rapidly break down, and that expectation was borne out by the tests on rail No. 13, which had the highest sulphur and gave the worst alternating tests.

The number of revolutions obtained before fracture should bear some relation to the stress applied, but in the table that did not appear to be the case, and indeed in several cases the number of reversals of stress up to fracture was greater with the greater stress than with the less, as shown in the following instances:—

No. of Sample.	Ranges of Stress in Tons per Square Inch.		
	35·6 Tons.	36·7 Tons.	40 Tons.
1	306,000	372,000	...
4	89,000	...	86,000
5	...	51,000	66,400
913	205,500	215,000	...
13	...	25,000	25,600

Those irregularities might be due to irregular distribution of sulphide
1908.—i.

E

and silicate of manganese fibres in pieces taken from the same rail, and if so they emphasised the objection already raised as to the direction of the fracture along the fibres.

Mr. W. R. WEBSTER (Philadelphia) said that Dr. Stanton's results were very interesting, and it was to be hoped that he would continue them, as it was only after a large series of tests of this kind that any satisfactory conclusions could be arrived at. He might say that they would welcome such tests in America. Fig. 5 showed the manner of cutting the specimen from the head of the rail, and the action of the rolls on the small specimen corresponded with those on the locomotive driving-wheel; but these specimens should also be cut with the axis of the short cylinder parallel with the length of the rail in order to bring out any differences in the structure of the metal due to the method of rolling. He referred to this matter, as recent experiments made by Mr. Howard at the Watertown Arsenal, Massachusetts, from thin plates of steel about $\frac{1}{16}$ th thick cut from the head of a rail had shown very decided transverse weakness. These small strips when bent lengthwise would bend 180° about a diameter of $1\frac{1}{4}$ inch, but when bent transversely would only bend about 20° and split lengthwise. They were all familiar with that in plates of low carbon steel, but with the higher carbon steel it was often overlooked. The results of the work at Watertown would be given shortly, and he would take great pleasure in sending to the Institute photographs and specimens bearing on the points he had raised.

Dr. STANTON, in reply, said that he should be very glad to add in the tables the elasticity statistics to which Mr. Gledhill referred. He was very much obliged to Mr. Hadfield for the kind way in which he had spoken of this work. With reference to the action of the rails in practice, the Great Northern Railway Company did not supply him with any details as to whether they were satisfactory or not satisfactory, except in one particular case, which was the No. 11 rail. It was the nature of the test which he wished to illustrate in the paper, and not the results of any particular set of rails. He did not have the choosing of them; they came in the ordinary course of events to the laboratory to be tested. He simply wanted to call attention to this test as a rapid fatigue test which had certain advantages which other fatigue tests, he thought, had not. He was glad that several speakers had called attention to the position of the specimen. He was uncertain about the proper position of the specimen to choose, and as a matter of fact they chose that position because it was that in which the action of the wheel on the rail was most nearly imitated. They could easily cut them in any other direction, and he was exceedingly glad to have the opinion of several members on that matter. That was really what he was very anxious to obtain, and he was very much obliged to Mr. Webster for his suggestions as to the best position for the specimen. He would easily be

able to test specimens cut from that position, and to find out if there was any weakness of the kind Mr. Webster indicated.

On the motion of the Chairman, Mr. JAMES RILEY, Vice-President, a cordial vote of thanks was unanimously accorded to Dr. Stanton for his paper.

CORRESPONDENCE.

Mr. J. H. MIDDLETON (Sheffield) wrote that Dr. Stanton's method formed a very ingenious modification of the Wöhler test, and, regarded as a scientific demonstration, was of considerable interest. It appeared, however, to be offered as a practical testing method having special application to the study of steel rails under conditions of ordinary use. Before such a claim could be admitted, it would be necessary to give more conclusive proof with regard to the following important points: first, the relation which the stresses in the test piece bore to those of the whole rail (*i.e.* the complete section) when in the track; second, the capacity of the new test to determine factors not given by previous methods. On attempting to apply these rotation tests to practical problems, such as the comparison of samples of steel of identical composition but varied treatment, the following difficulty was encountered: either the specimens must be run under a uniform load, or the loads must be varied in proportion to their previously determined elastic limits. In the first case the results—within the limits of experimental error—were in direct relation to elasticity, and in the second they were incomparable, because the sample which gave high results under the uniform load might not break down under a comparatively few rotations, and *vice versa*. Regarding the method under discussion, the results of the three series of tests were very discordant, showing the possible experimental error to be very considerable; but the first series, it will be noticed, was in almost perfect accord with the maximum tensile stresses given. As to the practical application of Dr. Stanton's test, it should be remembered that the amount of effective work on a steel rail varied very considerably in different parts. The question might be therefore asked whether it was fair to take a small sample from the least worked portion and assume it to represent the working condition of the entire section of the rail, because the usual static tests did not pretend to do that. Again, it could scarcely be maintained that the whole rail in the track was subjected to cyclic stresses such as those to which the rotary test piece was submitted. The latter would not be an easy piece to machine accurately and uniformly, and there was the further objection—considering the thinness of its walls—that a very small slag enclosure or mechanical defect would unduly localise the fracture, especially in a longitudinal test. His (Mr. Middleton's) experience led him to believe that the predominant factor in the resistance to shock or fatigue—

for a specified carbon content—was the relation which its elongation under tensile stress bore to its elastic limit. In other words, when elastic limit elongation = x max., the highest shock resisting quality would be obtained for that particular carbon content. During recent years the number of shock or fatigue tests had greatly, perhaps unnecessarily, multiplied, especially considering that they were all comparative in the sense that none of them yielded unique information on the modus of fracture. Dr. Stanton's method appeared to partake of that general character, and until more conclusive proof of its distinctive and representative nature could be adduced, it would be a mistake to introduce it as a practical test for steel rails.

Mr. O. C. MORGAN (Rotherham) wrote acknowledging the ingenuity of the method, but thought, from the results given, there were some anomalies which would seem to require further investigation before the method could be used commercially. Not all the specimens tested gave similar results compared one with another in the three sets; thus No. 4 rail came seventh in the number of reversals it stood before fracture in set I., it was second in set II., and fifth in set III. Again, rails numbers 13, 8, 10, 913, and 1 stood more reversals in set III. with a heavier load than in set II., the reversals in the case of rails 913 and 1 being actually more in number in set III. than in set I. with the lightest load of all. It was also to be regretted that the ordinary mechanical tests applied to rails had not been made on the specimens experimented on, and that full particulars of the tensile tests, &c., were not included in the paper. In any new method of testing it was important to be able to compare the results, at least with the commercial methods already in use, as it might be found that the one might be expressed in terms of the other, and even if possible mechanically, which was improbable, it was impossible, from a commercial point of view, for a manufacturer to have machines to reproduce the exact stresses, &c., that the various steels he made have to undergo. Again, in that, as in several other new methods of testing lately proposed for different purposes, the area of the specimen was very small, and that left a great deal to the absolute mechanical perfection both of the machine itself and of the preparation of test pieces, and was also detrimental, having regard to the fact that any small irregularity, such as local segregation, which in the bulk in which the material was used would probably have little or no effect on it, would, if it happen to occur in the specimen, occupy a large proportion of so small an area, and consequently give results which might lead to mistaken conclusions.

Mr. C. P. SANDBERG (London) considered that Dr. Stanton's fatigue test was certainly a most interesting one, and it drew attention to a question which should be further followed up. The test would, however, call for very great care in the preparation of the pieces, and it also entailed rather too much time and expense for it to be applied

in everyday testing of rails during manufacture, but it should nevertheless be a very interesting and valuable method of comparing different qualities of rails, or steel in general, more especially as to the liability of a particular quality or composition of steel to fail owing to fatigue.

A considerable number of such tests, and taken from different portions of the rail, should be made to study the subject further. The nickel steel had, as might have been expected, shown good results in that respect, but he feared that, owing to the very great extra cost, nickel steel would, as hitherto, only be used for rails in comparatively small quantities for special purposes.

He was pleased to see that the rails No. 8 and No. 10 of his high silicon steel had shown such marked superiority over the other ordinary quality rails tested, especially No. 8, with the highest silicon percentage, viz. 0.441 per cent. Many railway engineers had expressed themselves highly pleased with the results of the testing of his (Mr. Sandberg's) improved rail steel, and also with regard to the safety and wear in the track up to date, in the discussion on his paper on "The Chemical Composition of Steel Rails and Latest Developments," at the Engineering Conference of the Institution of Civil Engineers in 1907. In Mr. Ross's recent communication on rails in the *Journal of the Junior Institution of Engineers*, some very interesting figures as to the wear and cost of different qualities of rails were given, also showing in favour of the silicon steel rail. Some engineers had, however, raised the question of its possibly failing in time owing to fatigue, and although there was, from a metallurgical point of view, no reason why that tougher steel should fail in that respect, he was very glad to see that independent tests, as carried out by Dr. Stanton, had shown its advantages in that respect likewise.

Dr. STANTON, in reply to the correspondence, wrote that the chief criticism with which he had to deal referred to the want of uniformity in the results of the tests as given in the table. In the first place, taking the results of sets 1 and 2, and correcting the error which had unfortunately escaped him in revising the first proof, *i.e.* that the figures for rail No. 4 had been transposed, the correct values being 86,000 for set 1 and 39,000 for set 2, he did not think that any one who was familiar with fatigue-testing would consider them discordant. With reference to the discrepancies between sets 1 and 3, it must be remembered that the accuracy of the elastic theory by which the stresses were calculated was not of a high order, and would depend on the depth of the metal in the ring. He had come to the conclusion that the depth of the metal of the rings used in set 3 was too great to allow of an accurate determination of the stress, and he regretted that he had inserted this approximate value, since it had evidently misled some of the contributors to the discussion and correspondence. Mr. Middleton's criticism that the tests were of little value on the ground that under a uniform load the results ought to be "in direct relation to elasticity," apparently indicated that he

was not aware that the chief object of fatigue-testing was to discover the existence or non-existence of a relation between the elastic properties of a material and its resistance to fatigue. Mr. Middleton's confidence in its existence was certainly not shared by authorities on the subject, as was evident from a recent controversy.* If that relation was discovered, it might be predicted that fatigue-tests would no longer be made; but, until the question was settled, the multiplicity of fatigue tests which Mr. Middleton deplored appeared likely to continue, since it was evident that the existing ones were inadequate for the solution of a problem of the highest engineering importance. Whether the particular one discussed in the paper would throw any further light on the problem of fatigue remained to be seen, but it was certain that, as regarded tests on rails, it reproduced the conditions of wear in practice in a way that was not even approximated to by any other test.

Mr. F. J. R. CARULLA then read his paper on "Cast Iron in the Construction of Chemical Plant."

* *Engineering*, June 5 and 12, 1908.

CAST IRON IN THE CONSTRUCTION
OF CHEMICAL PLANT.

BY F. J. R. CARULLA (DERBY).

LIEBIG, in one of his classical letters on chemistry, points out the important functions that cork, platinum, glass, and caoutchouc play in modern chemical investigations; substances to the use of which he ascribes much of the progress that the science has made. The worker in the laboratory is soon impressed with their indispensable character, and more especially when he finds how little his pursuits are assisted by such common metals as iron and lead.

One can imagine the bewilderment of the young chemist who from the laboratory passes into the works to assist in any practical process, and is confronted with apparatus made of lead, iron, and wood, whilst, to all intents and purposes, every one of his valued materials have been discarded. Before he can be of much use he must become familiar with the properties of the new materials, especially in relation to the substances that the vessels they constitute have to hold, or that have to be produced in them, and altogether a new experience that sometimes has startling developments is entered upon.

Interesting as it might be, one cannot follow this line in all its details, and must content oneself to consider how iron, which so largely enters into the composition of chemical plant on the large scale, is calculated to produce surprises not often afforded by the materials that Liebig extols.

Wrought iron and its modern substitute, mild steel, do not need lengthy attention. The use made of the material for gas-holders and similar vessels need not be dwelt upon, and its value for bolts, bands, stays, and beams, when these can be painted or tarred to prevent corrosion, cannot be overlooked. But here the surprising thing happens, that although so easily corroded, tanks can be made of this material that will carry

strong sulphuric acid for years without damage being done to them. The only care necessary is that no water be admitted into the tank after use, when, of course, if left in, a weak acid solution would be formed and rapid corrosion ensue. Inattention to this requirement will certainly cause the destruction of a tank.

Cast iron, the main object of this communication, furnishes a substance that the chemical manufacturer could ill afford to be without, but which, in consequence of its varied composition and uncertain properties, is most difficult to classify. The consequence is that there are firms who possess experience and special knowledge of the use of particular brands for certain purposes that are unknown to the trade in general. Nevertheless some simple rules can be applied even in this case.

For some purposes, as, for example, ammonia stills, cast iron seems everlasting, and there can be no secret as to brands. One such apparatus, known to the writer, is as perfect to-day as when it was erected eighteen years ago, at any rate the cast-iron part of it. No sign of wear in any of the numerous cylinders; indeed, a remarkable thing was that the lower section of the lime cylinders, and the most important, as it has the manhole, leaked at the very start, a considerable blowhole making itself evident in the casting. Although the makers, with a full sense of justice, sent a new section to replace the faulty one, as the still was up, operations were started, making good the bad place with rust cement (iron filings and sal-ammoniac). Notwithstanding that the work is carried on at a pressure of eight to ten pounds per square inch, the place has not leaked since.

In the case of ammonia stills the reactions are entirely basic, lime being used to drive away the fixed portion of the volatile alkali, but even acid chemicals have sometimes little action on cast iron. It is wonderful to see the length of time that a nitre-pot made of this material will withstand the action of sulphuric and nitrous acids in a glowing furnace, the seething mass taking months and sometimes years to destroy the vessel. Yet when hydrochloric acid is in question cast iron succumbs like any weaker metal.

But whilst this is common knowledge the fact is not realised to its full extent. Percy* describes the experiments of Daniell, who obtained from a cube of cast iron, immersed in dilute hydrochloric acid, a spongy mass, easily cut with a knife, which was dark grey, somewhat resembling plumbago. He further gives Calvert's analysis of such a residue produced by the uninterrupted action of the acid during two years on cubes of the metal. Then he goes on to tell us of the similar action of sea-water on cast-iron guns got out of an armed vessel that fifty years before had sunk near Carlscrona, which were found to be changed to the extent of one-third into a grey porous graphitic mass. Finally, Percy repeats the well-known instance of the guns, also of cast iron, raised from the *Florida*, one of the vessels belonging to the Spanish Armada, which was sunk off the coast of Mull in Scotland, and which when brought up, the graphitic mass into which they had been converted became so hot that it could not be touched.

These accounts, spread over such long periods, are little calculated to impress one with the violent and rapid manner in which the action may take place. The writer found that the plug of a cast-iron cock, used to keep back ferrous liquor containing a very small percentage of free hydrochloric acid, was acted upon to the depth of one-eighth of an inch in a few months. This discovery was most opportune, for it caused the examination of a cast-iron vessel of considerable size into which the liquor in question was admitted, and a similar action was found to be going on. It was fortunate that this was per-

* "Iron and Steel," pp. 145-147. Calvert's analyses are given as follows:—

	Cast Iron.	Residue.
	Per Cent.	Per Cent.
Carbon	2.900	11.020
Nitrogen	0.790	2.590
Silicon	0.478	6.070
Iron	95.413	79.960
Sulphur	0.179	0.096
Phosphorus	0.132	0.059
Loss	0.108	0.205
	100.000	100.000

ceived at so early a stage, for as little damage had been done, by a variation in the process that is in no way detrimental, the action has been arrested, whilst the vessel is still good. Ammonia has to be used in the process, and a portion being put in at an earlier stage the acidity of the liquor and its injurious power are completely destroyed.

It is evident that this action of hydrochloric acid is one to be most carefully guarded against. Both the user and the maker of vessels that have to endure it are interested in the matter. Here then comes a distinction.

As you all know, cast iron is divided into two main groups, the white and the grey irons. The experiments of Professor Daniell, already referred to, showed that grey iron is more rapidly attacked than the white—three times as fast. Hence, if a cast-iron vessel is required to resist the action of hydrochloric acid, it is reasonable to say that white iron should be selected. But other conditions may have to enter into one's calculation, and if the vessel has to resist internal pressure, as is often necessary, the tougher grey iron is preferable to the white and brittle. The iron-founder is therefore placed between the horns of a dilemma, and the natural way to get out of the difficulty is to make a mixture of a white and a grey brand, the grey giving the tenacity and the white the acid-resisting power.

This, however, would not be so good as to cast around collapsible chills with grey iron, when the interior of the casting, assumed to be cylindrical, becoming white iron to a certain depth, would offer the required chemical resistance, whilst the outer coat of considerable thickness, remaining grey, would give the necessary tenacity. Vessels for chemical operations could certainly be produced on this plan if it has not already been done.

In connection with the action of hydrochloric acid there are operations in which not only the unexpected but the unsuspected may happen. Hydrochloric acid in its free state, and especially in its weak state, one knows that he must guard against, but chlorides seem so innocent that one is apt to overlook them. Now, ammonium chloride raised to 300° C. becomes dissociated, the hydrochloric acid being thus

set free, what wonder then that the iron tar stills* which are heated to the melting point of lead (325° C.) are affected by the ammonium chloride that has not been separated from the raw tar?

Another point which it is important to note, and which is frequently overlooked, is that of not using wrought-iron chaplets to hold up the cores of pipes, &c., that are to be employed for chemical work.† Failures are certain in such cases when the chemical has any action on iron, for the comparatively pure metal is more readily attacked than the cast iron. Even when cast-iron supports are used failures may result, as the fusing together with the main casting may not be complete. The method of casting pipes vertically without the use of chaplets is hence to be recommended for chemical work.

In view of such facts, and the circumstance that the chlorides loom so largely in the ammonia-soda process, one seems to have a key to the statement of Sir John Brunner regarding the early operations of his renowned firm, who said, "Between October 1873 and December 1874 everything in the works that could explode did explode, and everything that could break did break. And at the end of that fatal fifteen months we had nothing left but our credit."‡ Fortunately for the future of the ammonia-soda process that was good.

These questions have been recently brought close home to the writer when putting down the plant for the manufacture of the blue-black iron colour from ferrous liquor by Dr. Wülfing's process,§ much of which had to be designed to meet special conditions, and he has thought the matter may have sufficient interest for the members of this Institute to lead to an instructive discussion.

* Davis, "A Handbook of Chemical Engineering," 1901, vol. ii, p. 260.

† Grossmann does not overlook this. See his "Elements of Chemical Engineering," p. 113.

‡ *Magazine of Commerce*, 1904, p. 366.

§ *Journal of the Iron and Steel Institute*, 1907, No. III, pp. 204-206. When cold the ferrous liquor has to remain a long time in contact with iron scrap to be completely neutralised. Hence, in practice, liquor is received that is still active although it has been so treated. As it is subjected to operations in which heat is applied, its power to act on cast iron is then made evident.

DISCUSSION.

Professor THOMAS TURNER (Birmingham University) said the subject brought before them was of interest from many points of view. He regretted that he had but just had the paper placed in his hands, as otherwise he would have been glad to have brought some samples which would have illustrated the character of the action which Mr. Carulla mentioned. In connection with cast iron, or in fact with iron or steel in any form, it was known that alkalies were protective, and that was in accordance with the modern view of the production of rust, or what might be called the ionic theory of rust, which had been very well brought into public notice by Dr. Cushman in articles in the *Iron Age* and in other journals.* It was assumed by that theory—and it was found that it occurred in practice—that any hydroxide, such as ammonia and soda, would protect iron from rusting. When acids were involved it was a different matter. Very weak acids would gradually dissolve away the iron. Instances had come under his notice several times with regard to acetic acid, which, even though dilute, would gradually dissolve away the iron from a cast-iron pipe, and there would be a residue precisely of the shape of the original casting but extremely light, and sufficiently graphitic to write with as one would with a lead pencil, while it could be cut with a pocket-knife. In connection with the action of hydrochloric acid there was a special difficulty, and he knew at present of no variety of iron which would continuously withstand the action of hydrochloric acid. Experiments had been made, and he noticed that one or two patents had been taken out in the use of a siliceous iron. He had, indeed, suggested such a course long before those patents had been applied for—not indeed that he claimed any right concerning them. A very high silicon iron, with 10 or 20 per cent. of silicon, would stand the action of hydrochloric acid remarkably well, and if a fragment of about the size of a nut were taken and endeavours were made to dissolve it in hydrochloric acid, it would be found it was an extremely laborious process and that it would take a very long time to dissolve out the iron. But in practice, if a hydrochloric acid solution were boiled in a vessel made of iron which was fairly rich in silicon, it would be found that the hydrochloric acid insidiously attacked the siliceous iron, and although it might be better than a common iron, it was certainly not a perfect material. There were many other applications of cast iron in chemical manufacture in addition to those which had been mentioned by the author of the paper. One of the commonest was the treatment of nitre by means of sulphuric acid for the production of nitric acid. The pans did not wear uniformly; some of the pans lasted for a considerable time, and some were attacked in a relatively short period. The writer of the paper had pointed out that theoretically white iron would perhaps be better than grey. His experience was that a very open-grained iron,

* *Journal of the Iron and Steel Institute*, 1907, No. III. p. 520.

one containing, say, $1\frac{1}{2}$ per cent. of phosphorus or 3 or $3\frac{1}{4}$ per cent. of graphite, with the graphite in large plates, was very readily attacked by acids. As the metal became closer in the grain and the phosphorus was reduced, it was found that the effect of acids was not so marked, and with a close-grained iron corresponding very nearly to the old Staffordshire pig, an iron was obtained which would stand acids remarkably well.

Mr. F. W. HARBORD (London) said that the little experience he had had showed that white iron gave far better results than grey. There were several industries where boiling sulphuric acid had to be used, and white iron pans gave very much better results than grey; in fact, they were the only pans that could be used. In cases in which cast-iron tanks were used for holding molten metal, sometimes the cast-iron pot would stand for months, in another case a pot of apparently the same material would fail in the first week, and in those cases he had not been able to trace any difference between the grade of the iron. Certainly so far as acids were concerned, he thought there could be no doubt white iron was in every way preferable. It was difficult to get a sound casting in the white iron, but that had been successfully done in the case of the pans employed for gold refining in which boiling sulphuric acid was used.

Mr. J. E. STEAD, F.R.S., Member of Council, said that the paper opened out a very large field for discussion. The reason why strong sulphuric acid did not continuously act upon iron was that the acid produced a protective layer of sulphate of iron (insoluble in strong sulphuric acid) on the iron which completely protected the iron underneath the coating from further action. Precisely the opposite thing occurred with hydrochloric acid. When hydrochloric acid was put into iron vessels a very soluble chloride of iron was formed which escaped into solution, leaving the surface of the metal perfectly free to be acted upon by the acid. The question of the relative corrosion of grey cast iron and white cast iron had been made a special study in his laboratory many years ago, and it was proved at that time beyond all doubt that white iron was very much more resistant to hydrochloric acid than grey iron. The reason for that was not difficult to find. Grey iron was a heterogeneous mass of two entirely different substances, consisting of about 3 per cent. graphite which was electro-positive, and iron and pearlite which was electro-negative. In dilute acid electric action was set up at the exposed surfaces, and this effected a very rapid solution of the iron, whereas iron, when combined with carbon as in white iron, was a homogeneous substance. The greater the mass of carbide of iron present, the more resistant was the material to the action of the acid. He did not know whether Mr. Carulla had tried the making of chilled large pans and large faces in order to obtain that protective surface which he suggested could be made, but he (Mr. Stead) believed there would be a great many wasted during manufacture. The particular kind of grey residue,

shown by Mr. Carulla, found upon the surface of corroded cast iron very well known. He had met with it at different times, but the one thing he could not understand was how it was sometimes obtained by the action of steam upon grey cast iron. Why steam should have that action at one time and not at another had yet to be explained. Perhaps Mr. Carulla would give them some information upon that point. One remark fell from Professor Turner which bore directly upon the paper, and that was with regard to the effect of silicon in cast iron. He did not know whether those present that morning knew that Mr. Laurence Smith drew attention, many years ago, to the wonderfully resistant properties of silicon iron containing 20 per cent. of silicon. Mr. Smith gave him a piece of that iron. He polished it, and kept it in his laboratory exposed to the fumes of acids for a great many years, and yet the surface remained as bright as a silver mirror during the whole period. Of course it got dimmed by the condensation of fumes upon the surface, but a rag passed across it took away the condensed fumes and left the polished surface below quite as brilliant as it was originally. He did not think Professor Turner meant to suggest for a moment that cast-iron founders should use iron containing 15 or 20 per cent. of silicon for casting, for such material is very brittle. He was glad Mr. Carulla had brought that matter before them, and he hoped that ironfounders present would add something to the discussion.

Mr. F. W. PAUL (Harrogate) said he would merely refer to an incident that Professor Turner had recalled to his mind with regard to silicon preventing the attack of hydrochloric acid, and to what Mr. Stead had said on the point. He might himself cite an instance of 1 per cent. of silicon having proved itself most objectionable in the case of some Bessemer steel bars for tinplate manufacture. It caused so much trouble in the pickling by leaving a deposit that the subsequent tinning operations were almost impracticable.

Professor TURNER wished to offer a word of explanation in answer to Mr. Stead. He certainly would not suggest the use of silicon pig as a general rule; it was far too brittle, and there was far too much contraction. But a vessel could be cast in silicon iron which had not to be hammered or turned, and in exceptional cases it might be very useful.

Mr. CARULLA, in reply, said he anticipated and hoped to get a number of opinions and contributions to the paper from chemists and others, but he understood it was not the proper practice to read out any that he might have already received, but that such contributions would be published, with the paper, in the Journal. He might, however, mention that he had received a very important communication from Mr. Keville Davis. He had already anticipated some of the opinions that had been given, and absolutely confirmed much that Professor Turner had said. In the circumstances he (Mr. Carulla

must let his reply be simply a temporary one, for he should have to include in the final report an answer to the correspondence which would be received. Professor Turner had referred to the question of acetic acid. Mr. Haslam, of the Haslam Foundry Company, who had a great deal of experience in that sort of work, had also favoured him with a reply, and he was told that Messrs. Haslam had in some cases to give up iron, and had adopted aluminium, which was not acted upon in the manner that iron was. Mr. Harbord had confirmed his experience in connection with white iron. It was perfectly correct to say that white iron was less acted upon by acids than grey iron was. It seemed to him with regard to the objection that had been raised by Mr. Stead to Professor Turner's method of using the high silicon pig, that if high silicon pig really succeeded in withstanding the action, there would be methods found for making such iron useful for interior linings of castings, or, for the matter of that, applying wrought iron outside to give the necessary tension. Such an arrangement could be easily obtained if only success could be met with in getting a really resisting iron. The question was: Was that very high silicon iron sufficiently resistant to pay for such work to be done, because if it was only going to last, roughly, double the length of time that an ordinary iron would last, it was obvious that it would not pay to construct an expensive vessel in the manner that he had just suggested in order to make it strong. When once the silicon iron was attacked, and the acid went through, the whole vessel would, of course, be destroyed. The point that Mr. Stead had mentioned about steam having such an extraordinary action was most interesting. He confessed that with all his experience that was quite new to him; he was much obliged to Mr. Stead for bringing it out, and it showed the value of these discussions. He would not like to say that steam might not be to some extent at the bottom of the difficulty that he had experienced; it might have something to do with it. That applied to the vessel, but certainly not to the cast-iron cock. Steam did not touch the cock at all, it was only the ferrous liquor, which was a little acid, and that contact with the cast iron in something like three months really made an impression of about $\frac{1}{8}$ of an inch, and as he mentioned in his paper that led him to look into the vessel, and he found that the vessel had undergone similar corrosion. He would not like to say that steam had not had a little to do with it too. He could not explain it, except on the ground that extremely pure materials seemed to have a very different action from impure ones. Steam, of course, was extremely pure water, and it might be that extremely pure water had an action on cast iron that ordinary hot water would not have.

The PRESIDENT invited the members to accord their thanks to Mr. Carulla for his interesting paper, and their gratitude to him for having been the cause of a discussion which certainly was very valuable. It seemed to him that the observations which fell from Mr. Stead went to the root of the matter, though Mr. Stead had not

perhaps put it quite in the unphilosophic way he was going to do. Physicists were rather apt to lose sight of a peculiarity of matter, which he would venture to call its "cussedness." That only meant that they did not know enough about it. If they were in the full possession of that knowledge, for which Mr. Stead disclaimed a large part of his share at all events, then no doubt they would be under no difficulty in offering explanations of all these subjects. But, after all, if that were so the Institute would cease to have any ground of existence, because if they knew everything they should not want to tell one another what they had found out. One could only be grateful to nature for having been sufficiently complicated to leave considerable fields still unexplored. One of those had been indicated by Mr. Carulla. Perhaps he might add a contribution of his own to the discussion from a somewhat different point of view, not on the corrosion of iron, but on the way in which materials with which one was dealing with continually behaved in an entirely unexpected manner. It was recalled to his recollection from his own ammonia-soda experiences, where they were dealing with very large quantities of what they regarded as extremely dilute fluids, and yet every pipe they had about the place speedily filled up by incrustations. It would not have been thought conceivable that crystallisation would have taken place out of such dilute liquors, but it did, and the consequence was they had to take up every single pipe and replace them by channels, of which they could take off the top and chip off the adhesions, which would not have been there if nature had been organised in a proper way. With these somewhat irrelevant remarks he would ask the meeting to record by acclamation their thanks to Mr. Carulla for his paper.

The resolution was carried with acclamation.

CORRESPONDENCE.

Mr. G. KEVILLE DAVIS (Davis Brothers, Manchester) wrote:—The resistance that cast iron offers to corrosion by sulphuric acid is very considerable, provided the strength does not fall below 98° Tw., and we have found this property of great use during the last half-dozen years in making plant for the de-arsenication of sulphuric acid. The form of de-arsenicator somewhat resembles a continuous ammonia still, and we have found that the metal is practically unacted upon by acid of strengths between 100° and 110° Tw. Some of the plants have been in constant work for the last five years, and are still in good order. Sulphuric acid at 90° Tw. is very destructive to any cast-iron work.

With regard to the author's remarks on the action of chlorides on cast-iron work, the following experiment, which we made a few years ago, will show the kind of action that takes place on iron vessels.

We boiled a 12 per cent. solution of ammonium chloride in a glass retort with some pieces of hoop iron, the superficial area of which was 25 square inches; after about one hour's boiling we found that $2\frac{1}{2}$ grams of iron had been dissolved, which is a very considerable figure. The vapours coming away from the retort were quite alkaline, thus showing that the ammonium chloride was being decomposed, and there is no doubt that HCl in this condition is very destructive to all iron work, both cast and wrought.

One of the difficulties that is most common with cast-iron apparatus is the local action that frequently takes place, resulting in extensive pitting of the surface. I know of no reasonable explanation for this, but if care is taken to get castings as homogeneous as possible, this action is considerably reduced.

We have found that liquors containing dissolved iron—*e.g.*, after precipitating copperas with strong ammonia liquor—if the carbonic acid has not been driven off, are very destructive to cast-iron work, and when it is necessary to perform this operation, care should always be taken to get rid of as much of the carbonic acid as possible. Regarding the chemical composition of cast iron, it is of course well known that a certain amount of combined carbon seems to be necessary, and phosphorus and sulphur must be kept within low limits if the vessels or apparatus are to have a reasonable life.

Mr. W. HENRY FRYER (Lydbrook, Glos.) wrote:—I was much interested in reading the paper on cast iron in the construction of chemical plant, although not having the same direct interest in the subject I once had, when my patent for drying the blast was in force. I certainly tried several alloys for resisting without corrosion the action of calcium chloride in cold solutions, with free access of air; but although some of them were scarcely affected, others were very much so. I also evaporated a solution of the chloride by boiling it until the temperature rose to about 340° F. I rather expected that this would corrode the cast-iron pot containing it, but to my surprise the only visible effect was to clean and brighten the inside of the pot, without forming any peroxide; and the chloride, when poured out and left to solidify, was as white as when put in.

Dr. J. GROSSMANN (Manchester) wrote:—I am pleased that the attention of such an important and powerful society as the Iron and Steel Institute is directed to a subject which, in my opinion, has not so far received the attention it deserves. The effect of the chemical composition of iron and steel on its mechanical properties has been thoroughly investigated, and excellent work has been done in that direction by those engaged in the industries as well as at technical colleges; but as far as regards the connection between chemical composition and the resistance to chemical action is concerned, very little has been done. It appears to me that this is pre-eminently a field of research which should be exploited at our technical colleges, and which, whilst being instructive to the students as an introduction to

technical research, would yield data of great usefulness to manufacturers.

There are many directions in which work on such lines can be done. I have myself for some time been engaged in studying the corrosive action of magnesian and other waters and solutions on iron and steel under pressures of 100 lbs. to the square inch and more, and have read a paper on the subject before the Manchester Section of the Society of Chemical Industry on May 1, 1908, which I expect will shortly appear in the Journal. The method which I use enables me also to determine the relative resistance of different grades of iron, steel, copper and other metals, brass, gun-metal and other alloys to chemical action in the laboratory to waters and solutions under pressure, and thus to ascertain facts relating to these matters which up to the present could only be ascertained by costly experiments on a large scale. It has also enabled me to find a means of stopping the corrosive action of sea water; but my work only touches a small portion of what can be done in that direction, and I hope that Mr. Carulla's paper will rouse further interest in this important subject, and lead to further research.

Mr. W. G. HASLAM (Haslam Foundry and Engineering Co., Ltd.) wrote:—Our experience with acids has compelled us to seek for other metals than iron to resist their action in some circumstances. Thus we have experimented with aluminium, a piece of which has been immersed in a bottle of acetic acid for the past six years without any appreciable deterioration of the metal. For many years we have been making castings of a special bronze mixture to resist the action of hot dilute sulphuric acid, these castings being used in the process of converting starch into sugar, and this mixture might possibly also resist the action of hydrochloric acid. Though durable, these castings are expensive, say from four to five times the cost of iron castings.

Mr. HENRY HEMINGWAY (Stratford, E.) wrote that, although he has done considerable work in chloride of iron, it has not been in any way that bears on the construction of plant. He would point out, however, that the danger line in all iron constructions is just where the moisture and air meet, as in iron pillars to a bridge standing in water. The greatest care is to watch the three inches or so above the water-line.

Mr. EDWARD JACKSON (H. M. Inspector under the Alkali Acts, Birmingham) wrote:—The subject dealt with in Mr. Carulla's paper is of the greatest importance to those carrying on chemical manufacturing operations. One is frequently hearing of difficulties. Ammoniacal liquors are shown now to contain chlorides in notable quantities. I have recently seen figures where practically the whole of the fixed ammonia in the crude liquor is as chloride. As is well known, in certain seams of coal chlorides are present in important quantity. A case has recently come under my notice where serious damage has been observed in ammonia distilling and concentrating

plant, to the steel parts especially; also the cast-iron portions have been affected. In this case it is found that about two-thirds of the fixed ammonia in the crude liquor distilled exists as chloride. Also the wearing of tar stills has in some cases been so serious, when chlorides are present in quantity, that it has been found impossible to conduct the operation of distilling in the iron stills unless the tar has been previously washed to extract the harmful chloride of ammonium, so great was the destruction of the iron plates.

Another point where the quality of the iron is of most serious import has come to my knowledge recently. In the concentration of sulphuric acid in glass retorts, the iron vessels in which they are placed over the fire sometimes give considerable trouble. It is quite common to see the metal, after being in use for a while, become swollen, like blistering; this is an indication to the workman that he must carefully watch this vessel, and it may be so worked for some time with safety. But in other cases I have known that, instead of the swelling out of the metal referred to, it has suddenly cracked, thus breaking the glass retort, losing the vitriol, and, what is worse, vaporising the acid which flows over the hot brickwork into the fire, to the annoyance of the district and damage to vegetation, in addition to the serious loss to the manufacturer. It has been suggested to me by persons of experience in this manufacturing operation, that the quality of the iron from which the pots are made is the cause of this difference in behaviour; and it is difficult, under the circumstances where conditions often appear quite similar, to find other satisfactory explanation.

These are three classes of operations where the quality of the iron used must be of importance. What does this all point to but the necessity for a more correct knowledge of composition and character of iron used, and the importance of endeavouring to find out what special constituents or method of manufacture are required to give the quality of metal desired. I do not think very much is as yet known on these points, and I hope Mr. Carulla's paper may stimulate investigation.

Mr. J. F. KEMPSON (Kempson & Co., Ltd.) wrote:—We have found no appreciable corrosion of cast iron in the sections of the sulphate of ammonia still (Coffey's principle). The sections are exposed to the action of layers of boiling alkaline liquid and above of steam, ammonia, sulphuretted hydrogen, and various other gases. No difference is perceptible between the action of the hot gases and liquor. We have found corrosion in cast-iron pipes between tar still and water level in condensers, which is probably, we should think (as Mr. Carulla puts forward), due to dissociation of ammonium chloride. In connection with Claus' kiln, we have found cast iron stand sulphur and sulphurous acid vapours.

Professor Dr. G. LUNGE (Zürich) wrote:—I must say all the author states on the action of acids on cast iron agrees with my own

experience, and would be borne out by the evidence of all other technical chemists. I would only add that I, for my part, would eschew the use of grey cast iron for any kind of apparatus where it must come into contact with hydrochloric acid in the free state, whether originally so or produced by hydrolysis or dissociation, as in the case of ammonium chloride. Even white cast iron is not to be depended upon in this case, although it certainly holds out much longer than grey.

What Mr. Carulla states to be *possible*, viz. producing vessels which consist of a grey cast-iron shell with a chilled white inner surface, is *actually done* at German factories.

The author does not mention another and more fundamental way of protecting the iron, both cast and wrought, against the action of hydrochloric acid, viz. *enamelling* it. This is also applied in many cases with fullest success, but there is a great difference between the quality of enamel produced at one place from that turned out at another, and great care has to be exercised in selecting the right channel.

Mr. THOMAS TYRER, Past-President of the Society of Chemical Industry, wrote:—Mr. Carulla's paper seems to me to require very little, if any, discussion by chemists. The ironmaster wants the facts, and his chemist should at least help in solving the difficulties in composition. On this point I am not an expert, but *I can* verify the experiences of the author.

Mr. JOHN WALLACE, C.E. (Bombay), wrote:—I can add nothing to the lore of cast iron, but I have seen native-made iron forged on a stone anvil, and have observed that it does not rust like English iron when exposed to the weather. The ironwork of the car on which the gods of the Kulu Valley take the air has a fine brown patina and no rust flakes. It is all charcoal iron.

Mr. J. T. WOOD (Turney Brothers, Ltd.) wrote, in reference to tannic acid, that it attacks both wrought and cast iron, though in different degrees, and the material is soon eaten through. In practice all our iron work, such as shafts, &c., which are likely to come in contact with tannin, we cover with gun-metal or brass. Of course, as is well known, the compound of iron and tannin is a black ink, and this is often very troublesome in a tannery, so that we avoid iron as much as possible.

Dr. C. F. WÜLFING (Hönningen-on-Rhine) wrote:—There are many firms that make it a speciality to cast acid-proof iron vessels for the different demands of the chemical industries. These are not much dearer than ordinary castings. Of course the way they are made is kept secret. The iron used in the vessels for my process should be the same as that employed in the manufacture of ingot moulds for casting open-hearth steel. But special acid-proof iron would be a still better material.

Mr. CARULLA, replying to the discussion, wrote:—It is clear from the remarks of Professor Turner and of Mr. Davis that a pure cast iron, or at least an iron comparatively free from phosphorus, is a better acid-resisting material than one that contains this element in large proportion, and it is probable that the difficulties mentioned by Mr. Jackson in connection with the vessels for glass retorts are so explainable.

For the special purpose of treating chloride of iron liquors, Dr. Wülfing practically confirms this conclusion, as moulds for casting steel ingots, either Bessemer or open-hearth, have to be of fairly good material, such as hæmatite. Having been so advised before the vessels for the manufacture of the blue-black colour were cast, some practical tests were made of the brands proposed to be used. Pieces were chipped off the pigs, and were immersed in the liquors, together with a piece of hæmatite with which to compare them. It was found that all were slightly attacked, but two of the brands practically only to the same extent as the hæmatite, and as they made a strong mixture there was no hesitation in allowing the vessels to be made of it. It is true the tests were made on internal surfaces of the materials, whereas the skin of the casting is what has to resist the action of the acid. Now, a pure metal melts at a higher temperature than one laden with phosphorus, and consequently the likelihood of the castings acquiring a siliconised skin is greater with the hotter iron, which may be supposed to react with the moulding sand, than with one melting at a lower temperature. Such a conclusion is quite consistent with the observations of Professor Turner, Mr. Stead, Mr. Harbord, and Mr. Paul on the subject of the resisting power conferred by silicon. At any rate, Dr. Wülfing appears to have found this protection sufficient. The skin of the casting may be supposed to act in some measure as an enamel, which, as stated by Dr. Lunge, is successful when of good quality in protecting iron from the action of hydrochloric acid. Can it be that the stone anvil mentioned by Mr. Wallace siliconides the skin of the Indian iron? I am sincerely obliged to Dr. Lunge for the information that vessels of grey cast iron with a chilled interior are actually produced in Germany. My suggestion was made simply from a close study of all the circumstances of the problem, and it seemed possible that others engaged in solving the same question might have come to a similar conclusion. In the circumstances it is reasonable to infer that it is a correct one. I sincerely hope that Dr. Grossman's appeal may result in research work being instituted in the manner suggested. It is obvious, as Mr. Tyrer says, that the primary work must be done by the chemist, the ironfounder can only follow. The facts mentioned by Messrs. Fryer, Haslam, Kempson, and Wood show in what great variety the problem may present itself. An alloy of cast iron with some other element that should resist hydrochloric acid would not necessarily be proof against the action of acetic acid. One that resisted weak sulphuric acid might still be amenable to tannic acid. The alloy

might be resistant when wholly in the liquid, but not so if only partially immersed as pointed out by Mr. Hemingway.

Although much remains to be done, the discussion shows that a great deal has already been accomplished in the direction of producing acid-resisting vessels of cast iron. I personally thank the contributors for having thrown so much light on this obscure but important subject.

THE METALLURGICAL AND CHEMICAL LABORATORIES IN THE NATIONAL PHYSICAL LABORATORY.

BY WALTER ROSENHAIN, B.A., B.C.E.
(COMMUNICATED FROM THE NATIONAL PHYSICAL LABORATORY.)

THE metallurgical and chemical laboratories of the National Physical Laboratory have recently undergone considerable extension and reorganisation; a short account of the present state of the department, with special regard to the work which is either in hand or which the department is capable of undertaking, may therefore be of interest to metallurgists.

In its present condition the department is separated into two divisions; of these, one—viz. that dealing with purely metallurgical research work, including more especially metallographic work—is still housed, very inadequately, in a number of rooms situated in the basement of old Bushy House. The other division, which deals essentially with metallurgical chemistry, is, however, housed in a newly erected building specially designed and equipped for the purpose, and situated in the grounds of Bushy House, a short distance away from the main building.

Dealing first with the former division, we find in the main room a series of laboratory furnaces of various types used for the production and melting, on a very small scale, of metals and alloys as required for research, or investigatory testing. These furnaces include various types of gas-heated furnace, including Fletcher-Russell's injector furnaces, Griffin's radial furnace, and also a rather larger Seger furnace working on natural draught and with an approach to regenerative heating of the incoming air. A Cunnynghame adiabatic muffle attaining temperatures above 1050° C. with the aid of a single large Bunsen burner is used for the purpose of annealing small specimens of metal, while a large Fletcher-Russell muffle is available for the heat-treatment of larger specimens. A bosh or tank, mounted on wheels, is provided for quenching

purposes. In addition to these gas-heated appliances, a number of electric resistance furnaces are also in use. These are tube-furnaces of various lengths and diameter, some being wound with nickel wire in the manner indicated by Dr. Carpenter, while platinum-wound Heræus furnaces are also used. The supply of current for these appliances is derived from the large storage battery of the laboratory capable of yielding up to 110 volts and of delivering in this room

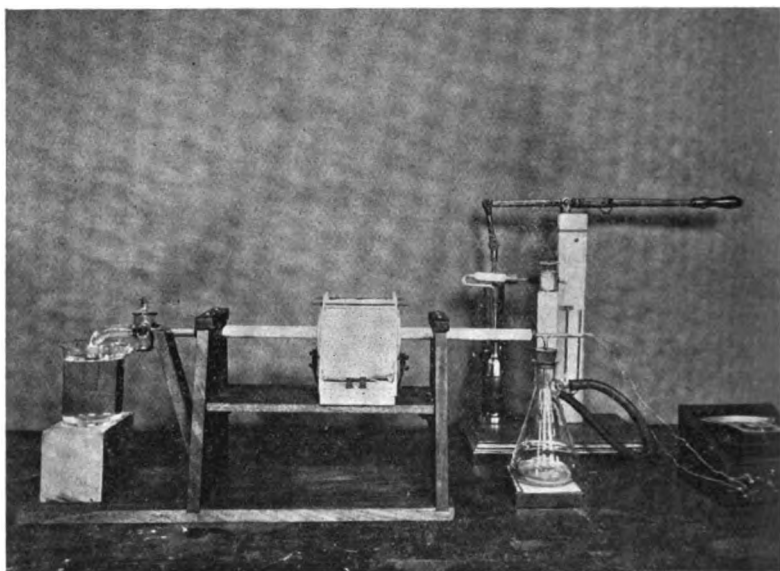

FIG. 1.

currents up to 150 ampères. In practice, however, 30 ampères are rarely exceeded. For the purpose of driving the gas-heated furnaces a mechanical blower is installed in this room, being driven by a 3 horse-power electric motor, the air being supplied at various points in the room by fixed pipes of large diameter. The motor just mentioned also drives a small hack-saw and a small drilling-machine.

The pyrometric appliances of the department are also mounted in this room; these include a potentiometer by Pitkin, of the type devised for this purpose by Dr. Stansfield. The galvanometer of this instrument gives its indications

by means of a spot of light on a scale, and a second spot of light on the same scale is derived from a second galvanometer connected with the differential thermo-junctions. The methods of taking recalescence curves by this instrument have recently been fully described and discussed by the author,* so that no further details are required here. For the purpose of determining melting and freezing points, as well as for taking "inverse-rate" cooling curves, a tapping-key is provided at the side of the potentiometer, and this is connected to a chronograph made by the Scientific Instrument Company of Cambridge; the seconds indicator of this instrument is connected electrically with the standard clock of the laboratory.

A recent addition to the equipment of this room is a novel form of quenching apparatus designed by the author, which is shown in Fig. 1. In this apparatus the specimen of metal to be quenched is heated in a horizontal tube of vitreous silica which passes through a short electric tube-furnace; the temperature of the specimen is indicated by a thermo-couple, which is held in contact with the surface of the metal, or may be inserted into a hole made in the specimen for that purpose. The one end of this silica tube communicates with a receiver and a Fleuss air-pump, by means of which it can be exhausted of air; the other end of the tube is attached to a wide-bore glass stop-cock communicating with a wide bent tube. The latter tube dips into a vessel of water or other liquid in which the specimen is to be quenched. The specimen having been maintained at the desired quenching temperature for the requisite time, the heating current is switched off, and the large stop-cock is opened. As the silica tube is exhausted the water rushes into the hot tube with considerable force, and not only chills the specimen but sweeps it down the tube, away from the heated part into the cold end. When the various parts of this apparatus are properly proportioned, there is no serious evolution of steam; the water rushes in very rapidly, and the resulting quenching is very sudden. The obvious advantages of this method of quenching are that the specimens of metal are not exposed to oxidation while being heated, and are not subjected to handling or

* Paper read before the Physical Society of London, January 24, 1908.

other manipulation tending to disturb their temperature prior to the sudden cooling; the quenching thus occurs at a definite temperature which can be ascertained with considerable accuracy. A further advantage is that, for microscopic examination, the surface of the specimen can be polished before quenching; at the end of the process the polished surface will only be covered with a very thin film of oxide or tarnish, and this can be removed by a few seconds' rubbing on the polishing disc. In this way any heating of the surface of the quenched specimen during subsequent polishing can be entirely avoided. While primarily devised for the purpose of quenching some aluminium-manganese alloys which could not be heated in air without becoming completely oxidised, it is hoped that this apparatus will yield interesting results when applied to the study of the phenomena of hardening in steel.

The microscopic equipment of the department is placed in two rooms in the lowest part of the building, thus securing great steadiness and uniformity of temperature. In a small room, just large enough to accommodate it, is placed a Zeiss projection bench and camera, fitted with a Martens metallographic projection microscope. With this apparatus it is possible to examine the microstructure of metals under the highest magnifications by means of images projected on a white paper screen. While it is obvious that this method of examination is not capable of yielding such perfect images, or of allowing such minute and careful scrutiny as direct examination through the eye-piece of the microscope, it yet offers advantages for the purpose of examining large areas with a view to ascertaining the uniformity or otherwise of a specimen of metal and of deciding on the choice of a typical field for photographic reproduction. Attached to the room containing the projection apparatus is a small dark-room in which the plates used for photography are changed and developed. For printing, enlarging, and other photographic manipulations a separate and larger dark-room is provided in another part of the building.

The second room in the basement is devoted to microscopic work also. For the detailed examination of metal sections under the most favourable conditions, one of the metallurgical

microscopes designed by the author* is installed on a bench specially devoted to this work, where arrangements for critical and oblique illumination are available by means of Nernst and other electric lamps. A full set of Zeiss apochromatic objectives and eye-pieces are kept here in special cases arranged to facilitate their rapid interchange. On a large stone bench in the centre of this room is installed the Zeiss ultra-violet microscope, with some special arrangements for illumination by monochromatic light. The whole constitutes a large and somewhat complicated piece of apparatus which is now giving great promise of valuable results. The work itself, however, is of a trying and difficult character, so that progress can only be slowly made; as the apparatus is still undergoing modifications, no description of the arrangement can yet be given.

On another bench of this room a Zeiss stereoscopic binocular microscope is installed, for use in the examination of fractures under moderate magnifications (up to about 75 diameters). Stereoscopic views of fractures are proving of considerable interest and value, particularly in connection with investigatory tests on material that has failed in service, and in connection with the experimental study of alloys, since the stereoscopic examination furnishes a good means of ascertaining the soundness of experimentally made metal.

In addition to the rooms already mentioned, as well as a small room serving as an office for the staff, two further small rooms are provided for the work of preparing the specimens of metal for microscopic examination. One of these rooms is provided with a pair of carborundum grinding wheels driven by a small electric motor; this room is entirely devoted to the work of grinding specimens, all emery rubbing being done here. The second room is devoted entirely to the last stages of polishing and etching. The polishing is done on a horizontal disc about 9 inches in diameter, covered with smooth "beaver" cloth and fed with distilled water and one or other polishing medium, such as diamantine, levigated rouge, alumina, or oxide of chromium. These are prepared in the laboratory in the manner indicated by Le Chatelier. With the last named of these substances it has

* *Journal of the Royal Microscopical Society*, 1906, pp. 146-155.

been found possible to polish such very soft materials as lead-tin alloys.

The progress of polishing is watched, when necessary, by the aid of a small microscope installed in this room for that purpose. This microscope is also used to enable the operator to judge of the depth and cleanness of etching attained in any given case. On a table in this room a series of etching baths are provided, and a rack of the necessary reagents is placed at hand. The reagent most frequently used for steel is a saturated solution of picric acid in alcohol, but nitric acid dissolved in amyl alcohol, as suggested by Kourbatoff, is also found useful. Means for electrolytic etching are also provided.

A small outbuilding specially erected for this purpose contains a small foundry plant attached to the department. The plant includes a Fletcher-Russell oil-fired injector furnace capable of melting 50 lbs. of metal and attaining heats adequate for melting all varieties of steel. An overhead carrying-gear and the usual equipment of moulding and casting appliances are provided for dealing with charges of metal of the size named. The large series of castings described in the Eighth Report of the Alloys Research Committee were made by Messrs. Carpenter and Edwards in this foundry, while a series of ternary alloys of copper and aluminium with other metals is now being prepared.

From the above brief description of the metallurgical research equipment of the laboratory it will be seen that the requisite appliances for a large range of metallurgical investigation are available. Such matters as the determination of melting and freezing points of metals and alloys, the determination of critical points, and of entire recalescence curves of steel and other metals, and the study of microstructure are undertaken regularly, either in the course of one or other of the various researches which the department has in hand, or in pursuance of investigatory testing of metallic materials. The researches at present in hand relate to the study of the properties of the ternary alloys of copper, aluminium, and other metals, undertaken at the request of the Alloys Research Committee of the Institution of Mechanical Engineers, and to the detailed investigation of the nature of eutectic alloys. In the latter

connection the alloys of lead and tin, and of copper and silver have been studied, but the investigation will also embrace the detailed study of pearlite and other eutectoid bodies. It is hoped that in this connection the added resolving-power of the ultra-violet microscope will render good service.

In addition to these definitely planned investigations, the department is frequently called upon to investigate and report upon the causes of failure of parts of structures or machines that have given way or become defective in service. A considerable number of interesting and important cases of this kind have been, and are being, submitted to the department, and there is reason to hope that the systematic study and recording of such cases will lead to valuable additions to our knowledge of the materials of engineering construction.

It will be observed that the equipment of the department, as described above, does not include any appliances for mechanical testing. This is explained by the fact that all such appliances are under the charge of the engineering department of the laboratory. When it is found desirable, the staff of the metallurgical department have access to, and use the mechanical testing appliances of the sister department, while in other cases the staff of that department co-operates. In the case of investigatory tests, the reports of the two departments are generally made jointly.

We turn now to the second division of the metallurgy department, which is housed in the new building, concerned chiefly with metallurgical chemistry. This division of the department differs from the other in one respect, since it is occupied—in addition to research and investigatory testing—with a considerable amount of routine testing work for Government departments.

A plan of the new building is given in Plate V. It will be seen that the building contains two large laboratories and a number of smaller rooms and offices. The largest room is that marked B on the plan, and this is devoted chiefly to steel analysis. For this work the room is provided with three large benches, a stone bench at one end, and four fume-cupboards. As it was obvious from the outset that the analysis of metals would necessarily involve the evolution of large volumes of

acid fumes, special attention was given to the question of ventilation. In the two large rooms this is provided for by a large trunk of teak wood placed under the ceiling along the south wall; this trunk has a sectional area of 2 feet by 2 feet 6 inches, and suction is supplied to it by a Blackman fan driven by an electric motor of $3\frac{1}{2}$ horse-power. The fume-cupboards are ranged along the south wall immediately beneath the exhaust trunk just mentioned, and communicate



FIG. 2.

with it by means of wide glazed earthenware pipes; similar pipes provide inlets to the exhaust trunk from the space immediately above a set of steam ovens, and also from the top of the hood, which extends over the stone bench placed at the west end of the room B, and the east end of the room C. (General views of rooms B and C are given in Figs. 2 and 3.) In addition to these arrangements, a small fume-chamber is provided on the central table or bench, the exhaust from this chamber being carried beneath the floor and thence up into the large trunk. There are also exhaust inlets, which can be

opened or closed at will, for withdrawing air from the highest part of the room, just under the apex of the skylight roof. Rooms B and C are chiefly lighted by a large north-light skylight running the entire length of the rooms, the light being well and evenly diffused by the white ceiling and walls, the former being boarded and painted with white "anti-sulphuric enamel," while the walls are covered with white glazed bricks. There are also large windows in the gable at the eastern end of room B, while a window, not shown in the plan, has subsequently been introduced at the south-west corner, for the purpose of assisting ventilation, and of acting as a means of exit in an emergency.

The general disposition of the rooms is as follows: the stone bench at the western end, shown in detail in Fig. 4, is devoted to the combustion apparatus for carbon determination, muffle furnaces for incinerations, &c., and a hot-plate with graduated temperatures, used chiefly for the solution of samples in connection with phosphorus determinations. The large bench next to this end of the room is used for the filtrations and titrations in connection with the volumetric determination of phosphorus, while the other side of the same bench is used for filtrations, &c., in connection with silicon determinations and the gravimetric estimation of phosphorus and sulphur. The central table or bench, upon which is situated the fume-cupboard already referred to, is used for volumetric sulphur and arsenic estimation, the apparatus (four sets of each being in simultaneous use) is shown in Figs. 5 and 6 respectively. The third bench is devoted to manganese and chromium determinations, and to titrations in connection with the arsenic and sulphur determinations. Room is also available here for the estimation of special alloyed elements such as nickel, tungsten, molybdenum, and vanadium. Along the east wall of the room is placed a lead-covered wash-up table with drying-racks, &c., while the north wall is occupied by shelves for reagent bottles and writing-tables for the accommodation of the staff.

Since the opening of this laboratory a very considerable number of samples of a large variety of steel have been analysed, the determinations of carbon, sulphur, phosphorus,

manganese, and arsenic being always carried out in duplicate, a check analysis by a second method being always made if the results of the duplicates are at all discrepant, or if the results found exceed the limits of the specification for the material in question. This work, having been carried out under the best conditions and with a view to testing the reliability of the various methods tried and adopted, constitutes valuable evidence as to the merits of the various methods used. It is therefore proposed to give a description of these methods, together with tables of comparative results and such critical comments as the experience obtained may justify.

Carbon.—The determination of carbon in steel by the process of direct combustion of the fine drillings in a current of oxygen has, after careful comparison with other processes, been adopted as the most reliable and at the same time the most expeditious method. The comparison has been made chiefly with the method as described by Blair, in which the steel is first dissolved in copper-potassium chloride solution and the carbon is separated by filtration and finally burnt in oxygen. As a rule, in the case of steel, the results of the Blair and the direct combustion process are in very perfect agreement, differences of two or three in the third decimal place alone being found; when, however, a larger discrepancy is found, this always occurs in the Blair method, careful repetitions uniformly confirming the accuracy of the direct process. The general conclusion arrived at is that while both the Blair and the direct combustion method are perfectly capable of yielding accurate results, there is a greater liability to accidental error in the former, while it also requires more complicated apparatus and occupies more time. These conclusions apply subject to the limitation that the drillings must not be coarse, and that the combustion apparatus used for the direct method is as efficient as that which is now to be described. The conclusion also applies only to ordinary steel and not to cast iron, pig iron, or other graphitic alloys, while it has yet to be tested as regards ferro-manganese, &c.

The combustion apparatus used for the direct method of carbon determination is shown at the right-hand end of the stone bench in the photograph, Fig. 4. At the right-hand



FIG. 3.

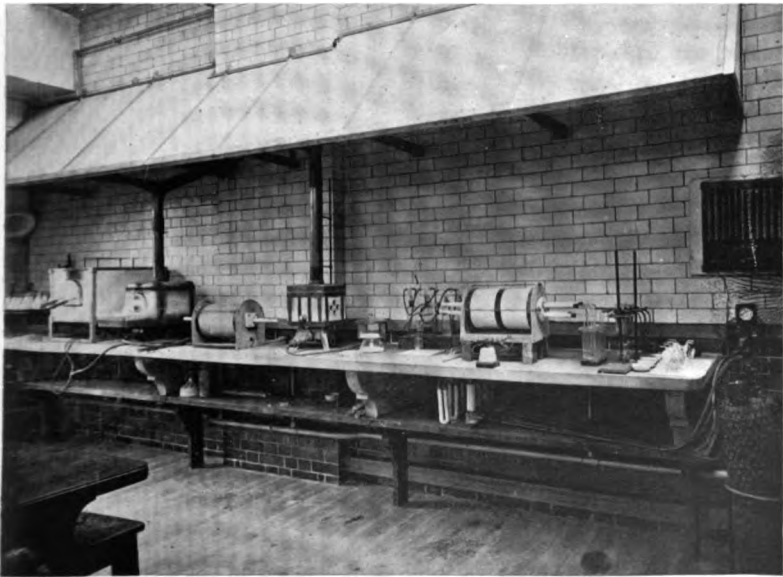

FIG. 4.

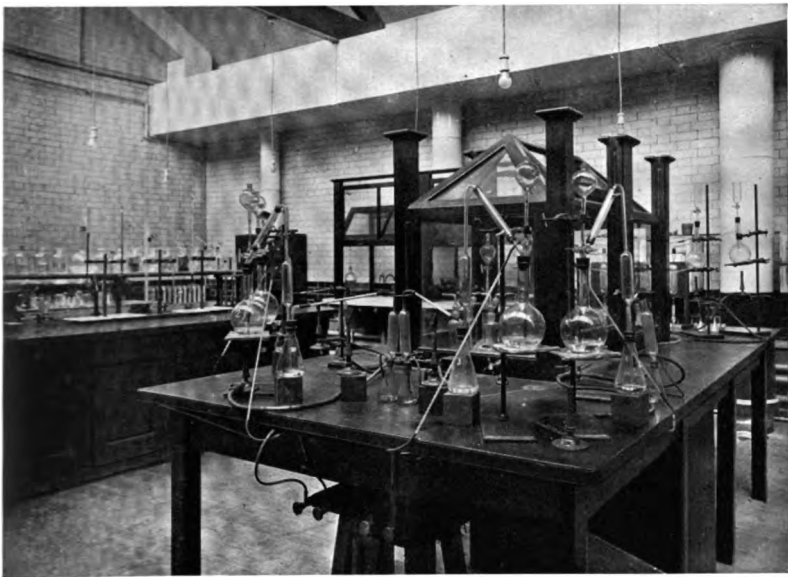

FIG. 5.

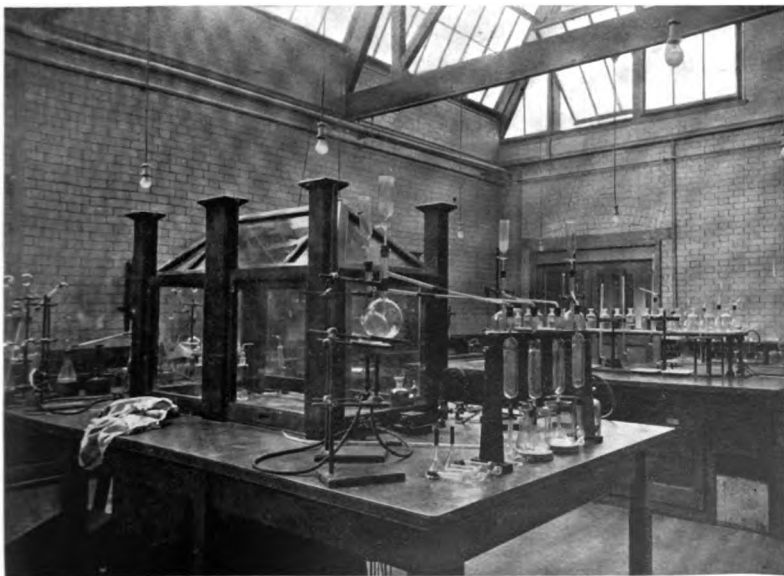

FIG. 6.

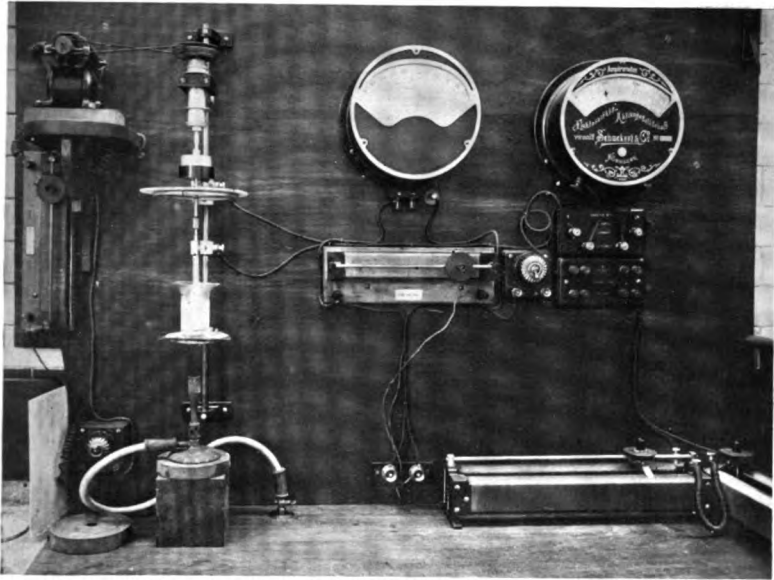

FIG. 7.

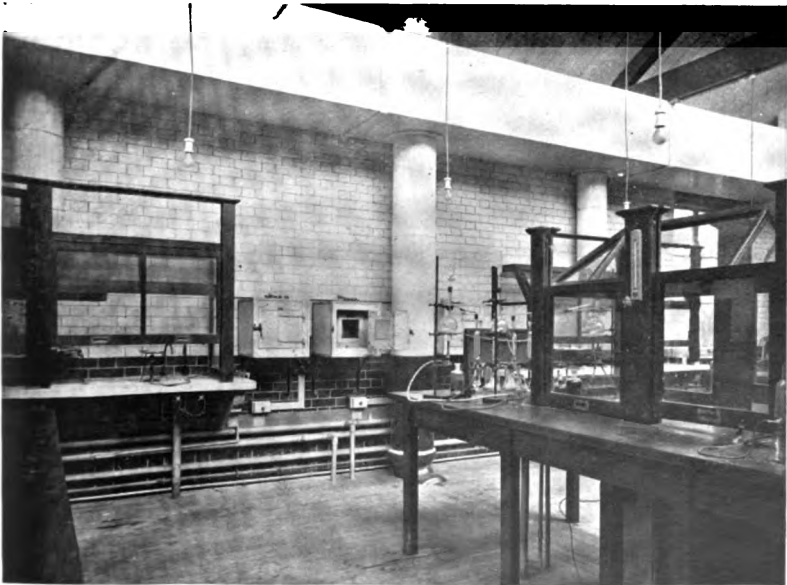
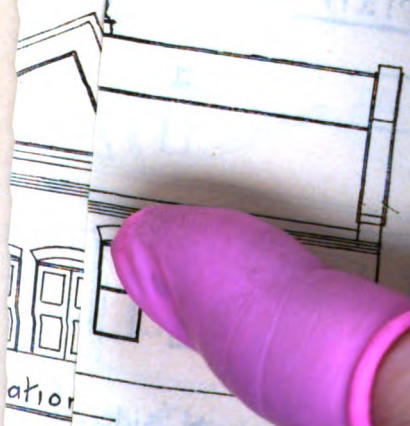
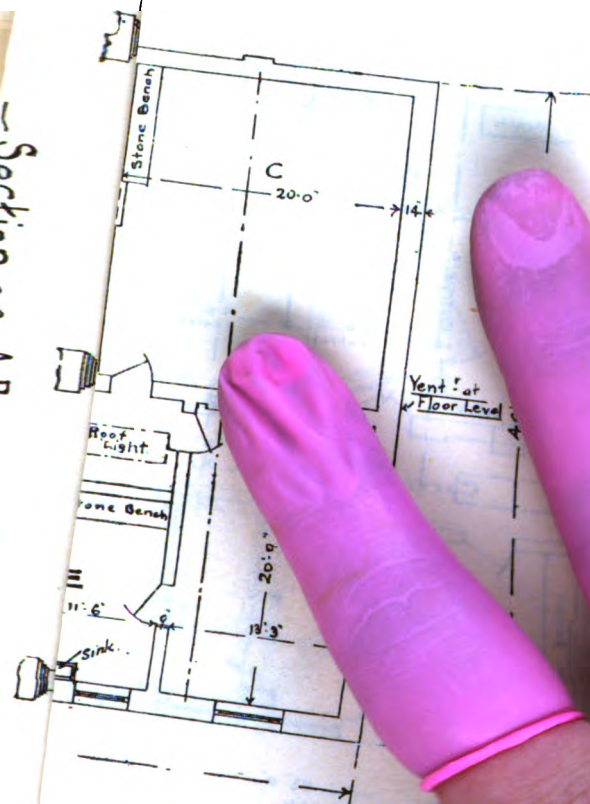

FIG. 8.

Section on A.B.

Section on A.B.



ation

end of the bench stands a large (60-foot) cylinder of compressed oxygen, provided with four independent fine-adjustment valves mounted on a fitting specially arranged for this purpose. From each of these valves a stout rubber tube carries the oxygen to a drying and purifying system, which is placed on a wooden shelf underneath the stone bench. The system in question consists of a tower packed with soda-lime, followed by a U-tube packed one half with soda-lime, the other half with calcium chloride, a separate tower and U-tube being provided for each of the four currents of oxygen. From the U-tube the oxygen is carried in rubber tubes to a set of Dreschel bottles containing sulphuric acid; these are placed in a raised position on the stone bench, so as to be visible to an operator manipulating the fine-adjustment valves on the oxygen cylinder; this operator thus has a guide as to the rate at which oxygen is entering the combustion tubes. The combustion tubes themselves, four in number, are tubes of vitreous (fused) silica, 28 inches in length and $\frac{3}{4}$ -inch in diameter; they are heated by a four-tube electric furnace, from which they project by 6 inches at each end; these tubes are closed with rubber stoppers at each end, and these remain perfectly cool and are not in any way acted upon, the only requisite precaution being to protect the inner face of the stoppers at the inlet end from direct radiation from the hot part of the tube; this is effected by the interposition of a short spiral of copper gauze. Originally the farther ends of these silica combustion tubes were packed with finely granular copper oxide, wrapped in asbestos paper with a view to preventing the oxide from coming into contact with and acting upon the silica tube. This protection was, however, found inadequate; whenever the temperature of the furnace was allowed to rise a little the copper oxide was very liable to fuse and to eat its way first through the asbestos wrapping and then through the silica tube, which it destroyed completely in a few minutes. The use of copper oxide has, however, been obviated by the employment of platinised silica. It was at first sought to obtain from the regular sources a supply of platinised quartz wool, but this proved unobtainable, and a trial was then made with fragments obtained by pound-

1908.—i. G

ing up parts of broken tubes of vitrified silica—these have a more or less rough surface owing to the drawing out of enclosed air-bubbles, and when platinised it was found that the platinum adhered well to the surface. Careful comparison showed that the oxidising action of this platinised silica was quite as satisfactory as that of copper oxide. Tubes packed with this material, which is readily renewed at suitable intervals, have now been in use for several months with very satisfactory results, the formerly high mortality of silica combustion tubes being entirely checked. It is a curious fact that while the action of copper oxide on these silica tubes is so very rapid, the small quantities of iron oxide which sometimes find their way into contact with the tubes owing to a fragment of steel being spilled from the boat, do not appear to affect the tube at all. In addition to the platinised silica, the tubes contain the usual lead-chromate packing for the absorption of oxide of sulphur.

The furnace in which the combustion tubes are heated is an electric resistance furnace having four separately wound heating tubes fixed within a single large heat-insulating casing of porcelain tube covered with "magnesia sectional covering." These heating tubes were originally made of porcelain and wound with fine nickel wire, but the furnaces made in this manner were found to require re-winding at intervals of about three weeks, thus causing a serious loss of time as well as trouble and expense. A winding of platinum foil on the principle of Heræus was therefore adopted, and this platinum foil was wound on silica tubes to avoid the risk of destruction by cracking, and also to reduce the deterioration of the platinum by electrolytic action as far as possible. The actual winding is so proportioned that when the furnace is at its proper working temperature (about 1000° C.) the resistance of the tubes coupled up two in series, and the two groups in parallel, is about 14 ohms. From a circuit having a pressure of 100 volts this takes a current of a little over 7 amperes, which is found just sufficient to maintain the desired temperature. For the purpose of starting up when cold, a switch is provided whereby the four tubes can be thrown into series, thus providing a higher initial resistance. This plati-

num-wound furnace has now been at work for three months without requiring any attention, and shows no signs of any change of resistance.

The steel drillings are introduced into the combustion tubes in long, narrow, and very light boats made in the laboratory by the aid of a "boatee" or press made by Messrs. Carling to the design of Mr. Stead. The boats actually employed are made very thin in the wall for the purpose of leaving as large a space available for the drilling as possible, since the dimensions of the combustion tubes which electric heating renders desirable are narrower than usual. At first some little trouble was experienced in making these boats, but the device of coating the moulds of the press with vaseline and interposing a piece of thin tissue-paper between the moulds and the clay has overcome this entirely, particularly when a specially plastic fireclay from Bavaria is used. The boats, when pressed, are dried and the paper is readily removed, but before use the boats are strongly calcined in a muffle furnace so as to be entirely free from carbon.

From the combustion tubes the gases are led through glass cooling tubes which dip into a large vessel of cold water, and thence into U-tubes of special construction filled with pumice saturated with strong sulphuric acid. These U-tubes are provided with glass stoppers at the top, and with a stop-cock at the lowest point of the U. Each day these tubes are filled up completely with fresh acid, which is allowed to remain in them for a short time, and is then drained away as completely as possible through the tap at the bottom. This leaves the pumice coated with fresh acid every day while removing any risk of splashing or bubbling that might arise with any excess acid present. From these drying-tubes the gases are led to the potash absorption bulbs, which are of the ordinary Geissler form. These are carried to the adjoining balance-room and weighed in the usual manner. In using this apparatus it is found quite possible for one operator to keep the four combustion tubes completely occupied, with the result that in a working day of from six and a half to seven hours one operator can carry out from eight to ten carbon determinations in duplicate (*i.e.* sixteen to twenty separate combustions), although at

times of pressure as many as twelve in duplicate have been completed in one working day.

For the purpose of comparison and check analyses, a complete set of dissolving and filtering apparatus for the wet separation of carbon is also available, and is regularly used in the case of cast or pig iron.

Phosphorus.—When systematic work on steel-analysis was first begun, the author was anxious to adopt the very attractive method of phosphorus determination described by Blair in a previous volume of this Journal,* and that method was carefully tried and compared with the standard gravimetric methods. While it was found that, as a rule, the results of Blair's method were in excellent agreement with those of the gravimetric methods, thus bearing out the results published by Blair, yet at times unaccountable discrepancies would occur. Sometimes these obviously arose from the fact that a small fragment of zinc had been washed down into the titration flask from the "reductor," and when this was seen to be the case the results were obviously and grossly in error; but less obvious errors appeared when no such occurrence could be detected, and the only conclusion appears to be that errors of this kind are liable to arise from the washing down of particles too minute to be observed. The reduction of molybdic to molybdous acid, as described by Blair in the method referred to, was therefore abandoned, and a modification of the method was tried, which has been described in various modifications by different writers. In the modification adopted in this laboratory, the yellow molybdate precipitate is obtained in the manner described by Blair in the paper referred to above; but instead of being dissolved from the filter with ammonia, the precipitate is washed first with weak nitric acid (2 per cent.) and then with a solution (also 2 per cent.) of potassium nitrate until the washings are neutral to litmus paper. The filter-paper with the yellow precipitate is then thrown into a flask and macerated with a little water. A small quantity of $\frac{1}{10}$ normal caustic potash (standard) solution is then added, in which the yellow precipitate immediately dissolves. The excess of alkali is then titrated back with standard sulphuric

* *Journal of the Iron and Steel Institute*, 1904, No. II. p. 239.

acid and phenol-phtalein. The somewhat complicated method of washing with acid and then with potassium nitrate is generally regarded as necessary, as it is supposed that pure water either slightly dissolves or modifies the composition of the yellow precipitate. A series of comparative tests has, however, shown that this supposition is not, perhaps, well founded, the results obtained when the yellow precipitate is washed with water alone being found to agree closely with those obtained by the more elaborate method. The following table shows a series of comparative results obtained by the volumetric method just described, and by the well-known gravimetric molybdate method as developed by Messrs. Stead and Harbord:—

Steel.	Lab. No.	Percentage of Phosphorus found by	
		Volumetric Method.	Gravimetric.
Joist	1041	0·068	0·069
Tube	1046	0·010	0·012
Joist	1054	0·061	0·066
Tyre	1090	0·043	0·044
Spring	1100	0·040	0·043
Spring	1146	0·043	0·044
Spring	1147	0·041	0·040
Tyre	1155	0·041	0·042
Shafting	1170	0·080	0·084

The following table shows results obtained on eight typical samples by the method of washing with water in place of nitric acid followed by potassium nitrate:—

Steel.	Lab. No.	Percentage of Phosphorus washed by	
		Acid and Pot. Nitrate.	Water only.
Spring	945	0·033	0·036
Axle	946	0·028	0·031
Spring	947	0·033	0·035
Axle	948	0·034	0·036
Spring	969	0·032	0·034
Tyre	970	0·028	0·029
Spring	971	0·022	0·025
Spring	972	0·031	0·035

From these tabulated results, covering a wide range of steels, it will be seen that the volumetric method described above gives results only very slightly lower than those obtained by the more elaborate and troublesome gravimetric method, the results of the two methods rarely differing more than two duplicate determinations made by either method are frequently found to do. On the whole, however, the results obtained by omitting the potassium-nitrate washing in the volumetric method are found to be very slightly higher than those found when that form of washing is employed, and this difference tends to bring the results still nearer to those found by the gravimetric method. Until, however, the precise effect of these two modes of washing has been more fully studied, the practice of this laboratory will adhere to the potassium-nitrate washing, although good ground for omitting this step may be found in the near future. The present practice therefore is to carry out the majority of phosphorus determinations by the volumetric method described above, but in the case of abnormal results, and occasionally in normal cases, checking the results by gravimetric determinations.

Sulphur.—Here also a volumetric (evolution) and a gravimetric method are used side by side in much the same way as indicated above for phosphorus.

The apparatus used for the evolution method is shown in Fig. 5, where four sets of this apparatus are shown in simultaneous use. It is found that one operator can work with four such sets without delay or inconvenience. The steel drillings are dissolved in the evolution flask of this apparatus in hydrochloric acid of 1.10 specific gravity, the operation being aided by heat, although boiling the acid is avoided. The evolution flask and entire apparatus are filled, prior to the commencement of the operation, with an atmosphere of carbon dioxide, obtained by passing a stream of this gas, derived from a cylinder of liquid carbonic acid, through the entire apparatus. The evolved gases, aided towards the end of the operation by a further stream of carbonic acid, are bubbled through an absorption flask containing a solution of cadmium acetate strongly acidified with acetic acid (25 grammes pure cadmium acetate and 10 per cent.

glacial acetic acid per litre); after passing this flask the gases pass through a narrow-bore tube of vitreous silica heated to redness by a Bunsen burner with a flat flame, the gases passing finally through a second cadmium acetate absorption flask and then away to the fume-chamber. When the steel has completely dissolved, the contents of the two absorption flasks are mixed and the yellow sulphide of cadmium is filtered off; this is a rapid operation since the flask need not be washed carefully—the operation is merely intended to separate the sulphide from the bulk of the absorption liquid. As soon as this has been done the precipitate is washed from the filter back into the original flask and there dissolved in 10 cubic centimetres of standard iodine solution, the action being aided by the introduction of a small quantity of hydrochloric acid. The excess of iodine is then titrated by means of sodium thio-sulphate and starch. It is to be observed that while this titration can be carried out in the liquid of the absorption flasks without filtration it has been found that this leads to occasional discrepancies in the results. Apparently, particularly in the case of high-carbon steel, the evolved gases carry into the absorption flask something which is capable of absorbing iodine, but which is not sulphur; this disturbing substance can be eliminated by the filtration described above.

Steel.	Lab. No.	Percentage of Sulphur found by	
		Evolution.	Gravimetric.
Tyre	896	0·042	0·044
Tyre	936	0·046	0·049
Tyre	952	0·045	0·049
Shaft	0·041	0·043
Tyre	969	0·014	0·013
Plate	980	0·048	0·045
Joist	1018	0·054	0·052
Joist	1054	0·062	0·063

The above table, which again contains typical examples from a wide range of steel, shows the closeness of the agreement observed between the results of this evolution method

and a well-known oxidation method which has been adopted for check and comparison purposes, viz. that described by Archbutt.*

It will be seen that the differences are very small and quite comparable with the order of variations found in either method alone. The evolution method just described is therefore used by the laboratory for all ordinary steel analyses (not cast or pig irons), abnormal results being always checked by the gravimetric method referred to above, while occasional check determinations are also made on samples giving normal results.

It is not proposed to describe in detail the apparatus and methods used for the determination of the remaining constituents of steel, since these are well known and do not differ materially from methods fully described in various papers and text-books. Thus arsenic is determined by a well-known evolution method in an apparatus shown—again in a set of four for simultaneous use—in Fig. 6. For manganese a colorimetric method depending on the conversion of manganese into permanganate is employed, the well-known "bismuthate" method being used as a check, while silicon is converted into silica and weighed in the usual manner.

The second large room (C) of the new metallurgy building (shown in Fig. 2) is devoted essentially to research work, such chemical research work being, as a rule, directly connected with or forming part of other research work in the laboratory. Thus all the analytical work on alloys and raw materials required in connection with the metallurgical research work is carried on here. For this purpose frequent use is made of electrolytic methods of analysis, and a special apparatus has been installed for the electrolytic deposition of metals. This apparatus is shown in Fig. 7. The system of electrodes described by Sands † has been adopted and a special arrangement for obtaining the necessary rapid rotation of the anode has been set up, together with facilities for the accurate measurement of current and potential. The installation of a capillary electrometer is also arranged for, and it will then

* *Journal of the Society of Chemical Industries*, January 31, 1890.

† *Transactions of the Chemical Society*, 1907, vol. xci.

be possible to use this apparatus for the electrolytic separation of metals by the method of graded potential.

In other respects the equipment of this room—*i.e.* as regards fume-cupboards, furnace-bench, drying-ovens, &c.—is very similar to that of room B, although not so large. In both rooms both steam and electrically heated drying-ovens are installed. The former operate with steam at a pressure of 10 lbs. per square inch, while the latter work with a voltage of 100 and a current varying from $\frac{1}{2}$ to $1\frac{1}{2}$ ampère. With the latter current consumption the ovens attain a temperature of about 250° C. This remarkable degree of economy is attained by the use of thick layers of heat-insulating materials, the heated space of these ovens being 6 inches cube, while the external size of the ovens is 1 foot 6 inches cube. The electric heating coils are, however, attached to a copper box which constitutes the inner chamber of the oven, and this can be entirely withdrawn for examination or repair without interfering with the insulating case. These ovens were made by Messrs. Brown to designs worked out at this laboratory. A group of these ovens in room B is shown in the photograph, Fig. 8.

The remaining rooms of the building are devoted to various subsidiary purposes. Room D is the office of the superintendent of the department, while E is arranged as his private laboratory. Room F is the balance-room in which four analytical balances are at present installed. Room G is the office of the assistant in charge of steel analysis, but is also furnished with a bench and fume-cupboard (with a flue and natural draught) for use as a chemical laboratory for special work. Steel samples are also received in this room. Room H is provided with a smooth cement floor and contains a set of Sodeau gas-analysis apparatus. This room is also used for glass-blowing. Room I is a store for apparatus and chemicals in frequent use, a larger storage space being provided in a loft over the rooms D to H. Room A contains a Fletcher-Russell gas-fired boiler capable of working the steam ovens and steam evaporating baths in rooms B and C if at any time the steam supply from the laboratory power-station should be shut off. This room also contains one of Messrs. Brown's patent stills, which is

capable of yielding well over 5 gallons of distilled water per hour. The photograph, Fig. 9, shows the arrangement of steam appliances in this room. The small room, lying between A and B, has been converted into a fume-chamber, and to this chamber all work with sulphuretted hydrogen is entirely confined. As a result of this precaution, and of the

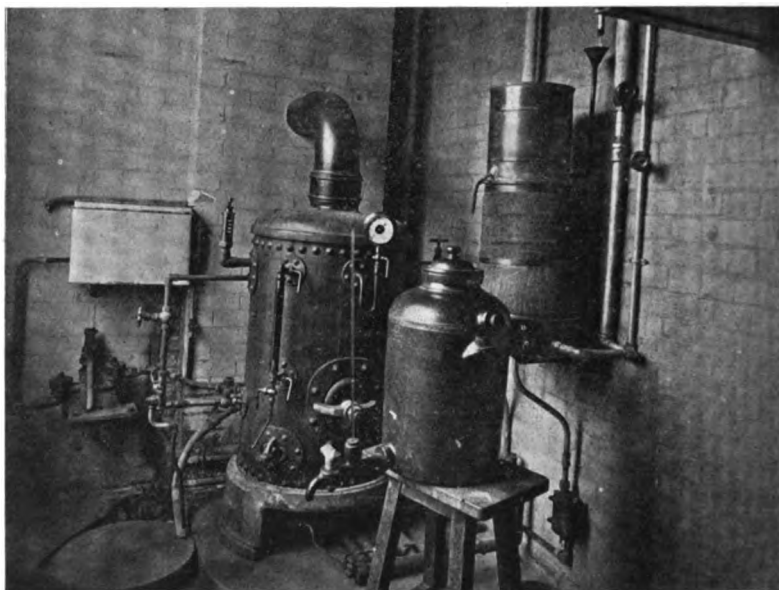

FIG. 9.

ventilating arrangements already described, the atmosphere of this laboratory is remarkably pure, even when large quantities of metal are undergoing analysis.

In conclusion the author wishes to express his thanks to the members of his staff who have assisted in the arrangement and development of much of the apparatus described, as well as in carrying out the comparison analyses referred to above, the gentlemen principally concerned being Messrs. Murdock, Gemmell, Archbutt, Lantsberry, and Withey.

DISCUSSION.

Mr. ROSENHAIN said that the paper that stood in his name had been in the hands of those interested, and there was no occasion for him to draw attention to it in any great detail. He would only refer to one or two points in it. The first was the quenching apparatus which was described in the paper. That apparatus had now been in use for some time since the paper was written, and it had been slightly modified and improved. He hoped it would be possible ultimately to measure the rate of cooling, but so far that had quite eluded his efforts. The rate of cooling appeared to be very rapid indeed. The actual results were not yet in a sufficiently forward state for publication, but they promised to be interesting. With regard to the chemical analyses which were outlined in the paper, he would merely draw attention to the tables on p. 101, which were merely a few examples taken through a great number of check analyses, illustrating the accuracy obtainable with those methods, and although those methods were found to be accurate in results they were constantly being checked by the gravimetric methods. Beyond that, he would only say that they should be very pleased to see any member of the Institute at the National Physical Laboratory that afternoon, if they cared to see those processes at work themselves.

The PRESIDENT said that Mr. Rosenhain's paper was hardly one which would lend itself to discussion, but they would very greatly value any written communications and comments upon the paper itself, and he was sure the Laboratory would be glad to receive observations from the members of the Institute on subjects which particularly belonged to their speciality. He would point out that the paper was one which they were entitled to expect from the Laboratory or somebody representing it. The Institute had largely contributed to the funds raised by the National Physical Laboratory, and it was only right and proper that some member of the staff should be deputed to put on record what work had been done. That was the *raison d'être* of the paper, and he thought they would readily accord to Mr. Rosenhain their thanks for having in that admirable way recorded what was being done. He hoped this was not the last they would hear of the matter, because, unless he was greatly mistaken in the spirit in which the Laboratory was conducted, there was but one thing that the staff would prefer more than to be found fault with, and that was to be told that it was impossible to find fault with them.

CORRESPONDENCE.

Mr. WALTER MACFARLANE (Wednesbury) wrote that the excellent paper by Mr. Rosenhain would prove most interesting and useful to metallurgical chemists, especially in directing towards the most reliable methods and modifications. A very important branch appeared, however, to be ignored, viz., analyses of fuels. An account of such analyses, including gas analyses, would be acceptable. In connection with the gravimetric molybdate method for the estimation of phosphorus, the work of Messrs. Stead and Cook ought not, he thought, to be overlooked.

THE PYROMETRIC INSTALLATION IN THE GUN SECTION, ROYAL GUN AND CARRIAGE FACTORIES, WOOLWICH.

By J. WESLEY LAMBERT, F.C.S.,
CHIEF METALLURGIST, ROYAL GUN FACTORY, WOOLWICH.

THE recognition of the excellence of the pyrometric installation in the gun section of the Royal Gun and Carriage Factories, Woolwich, by those firms manufacturing ordnance, and also by the larger steel-making firms throughout the kingdom interested in the thermal treatment of ordnance material, as expressed upon the numerous visits of their representatives, has prompted the author to give a brief description of the leading points of the system employed in the department.

Although of the numerous forms of pyrometers now upon the market each may be admirably adapted for temperature measurements under the particular conditions best suited to the instrument itself, it cannot yet be claimed for any one pyrometer that it is a practicable and reliable heat-measuring instrument under all the varying conditions met with in the arts and industries.

The introduction of the system about to be described, though admittedly only including a single type of pyrometer, has for its sole objective the control of the thermal treatment of the steel to be subsequently used in the construction of ordnance. Such thermal treatment for the purposes of this description is held to comprise the heating of the steel for forging operations under the steam hammer or hydraulic press, together with the subsequent annealing, oil-hardening, tempering and shrinkage operations.

The temperature control of the whole of these operations in the treatment of ordnance steel is admittedly one of great importance, and too much care and consideration cannot be bestowed upon the selection and installation of a properly devised pyrometric system of control.

Some attempt to control temperatures pyrometrically appears to have been considered in the department nearly fifty years ago. In the year 1862, Bystrom's patented pyrometer, exhibited and awarded a gold medal at the great

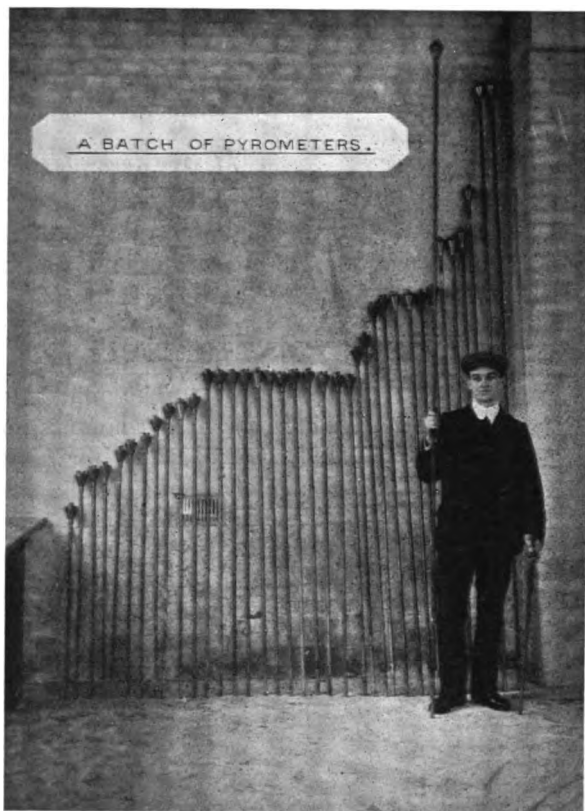

FIG. 1.

exhibition, was the instrument chosen for the experiments. This pyrometer is still in existence and in an excellent state of preservation. It is a prototype of the well-known Siemens water pyrometer. It consists of a small hexagonal vessel of zinc, 4 inches across the flats, neatly lagged with mahogany. Upon the top provision is made for the insertion of a thermo-

meter by a bayonet joint. A circular brass cap protects a funnel, the prolongation of which ends in the interior of the vessel in the shape of a wire cage so placed that it approximates the centre of the chamber. Water is introduced, and a small metallic ball or cylinder was the medium heated; the *modus operandi* being in all respects similar to that in the various well-known forms of water calorimeters.

The first mention in the records of the testing laboratory of the systematic use of a pyrometer for the purpose of controlling the thermal treatment of ordnance steel appears in the records for the month of November 1882. The entry reads: "Tempered by pyrometer at 1517° F.," by which is to be understood the operation of oil quenching. Closely following this record is an entry: "Tempered at 1450° F.," a temperature used for specimen treatment as a guide to mass treatment in the case of heavy forgings to this very day, and one quite familiar to all ordnance contractors to the War Department.

The pyrometer in those comparatively early days of systematic pyrometry was the older form of Siemens electrical resistance pyrometer with galvanometer and resistance box, several of which were in use for many years. A battery of these last-named pyrometers with their modifications as introduced from time to time, including the later pattern direct-reading instruments, the Siemens water pyrometer with heavy platinum cylinder, Murrie's patent pyrometer, Bailey's patent pyrometer (the expansion of a metallic rod), together with several patterns of optical pyrometers, constituted the types of instruments in use throughout the factory previous to the present uniform installation of the thermo-electric couple.

To Colonel Holden, F.R.S., R.A., the present superintendent of the Royal Gun and Carriage Factories, must be accorded the credit of introducing to the department the instrument now in use.

The thin edge of the wedge, which in course of time has dislodged all the other forms of pyrometers in the department in favour of the thermo-couple, was the introduction in 1900 of the simple instrument of the indicating pattern (Fig. 2), supplied by Messrs. James Pitkin & Co., of Clerkenwell, London, E.C.

The rapidity with which the temperature was "picked up" and any fluctuations in the heat bath indicated, at once established its utility and installed it in the favour of those officials in the department interested in high-temperature measurement.

The complete pyrometer consists of—

- (a) The thermo-junction;
- (b) An indicating galvanometer.

The thermo-junction simply consists of a more or less lengthy pair of wires of dissimilar metals, one end of each wire being twisted together, thus forming a junction which,

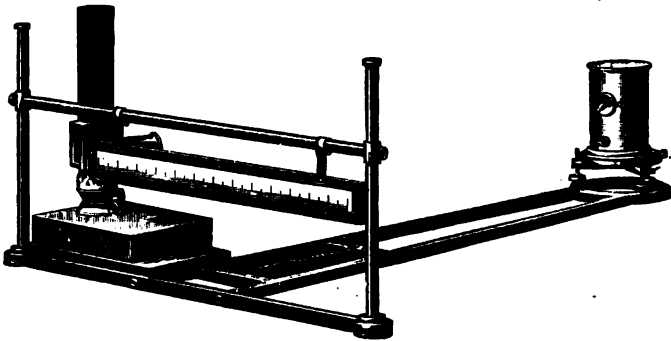

FIG. 2.

to all intents and purposes, is regarded as a battery, since such a junction when heated is the seat of an electro-motive force which is a function of the temperature.

The wires forming the hot-junction must necessarily withstand fairly high temperatures, seeing that the couple has to be introduced into furnaces, the heat of which sometimes exceeds 2000° F. A suitable couple consists of a pure platinum wire together with a wire of 10 per cent. iridio-platinum alloy, and thermo-couples of these two metals are used exclusively throughout the present installation. The free ends of the two wires are available for the copper leads joining up to the indicating galvanometer.

The wires of the couple for furnace work are preferably threaded through double-drilled fireclay tubes which serve to

keep them apart throughout their length, and the whole inserted in a covering sheath of gas or steam barrel, the junction end of which is closed by a thin iron disc welded securely into the end. To the open end of the sheathing is fixed a head which serves to carry two terminals, on the under side of which the ends of the wires forming the couple are connected, thus ensuring a clean contact. The copper leads to the galvanometer being attached to the exposed portion of the terminals, care is necessary to secure a clean contact whenever connection is made. A further detailed description, together with a sketch of a couple as in use in the present time, is given on page 127.

The galvanometer is of the reflecting type and of simple construction. It is a modification, devised by Colonel Holden over twenty years ago, of the D'Arsonval galvanometer, and consists of a built-up, laminated horse-shoe magnet, between the poles of which an adjustable frame holds a circular iron core round which a light silver "former" wound with a coil of wire partially revolves. This coil is held suspended between the top and bottom of the frame by a fine metallic strip of flattened phosphor-bronze wire. Fixed to the upper portion of the moving coil is a small, circular, silvered mirror, which serves to indicate any movement of the coil, in all respects similar to the well-known principle of reflecting galvanometers.

This form of galvanometer is particularly adapted for this class of work, and is practically dead-beat. Its internal resistance is about 80 ohms. The instrument is enclosed by a cylindrical brass cover having a small glazed aperture in the front, thus exposing the mirror. Fig. 3 shows the details of this galvanometer.

The great advantage gained by the use of the reflecting type of galvanometer for pyrometric work lies in the fact that it is possible to employ a much more extended reading scale than is practicable with other forms of instruments owing to the fact that it is much more sensitive. The electromotive force, it must be remembered, cannot be increased. Moreover, the scale being an arbitrary one, and also movable, any readjustment of the zero of the galvanometer is easily accomplished.

The galvanometer together with a suitable illuminating lamp and transparent centimetre scale are erected upon a rigid though light frame of cast iron.

Upon connecting up the couple to the galvanometer through the copper leads, any application of heat to the junction produces an electro-motive force, which, in its turn, causes the suspended coil to partially revolve; the mirror at the same time fulfils its function, and the beam of light upon the mirror is thereby reflected to a corresponding position on the scale.

This, then, was the first contribution to the present-day

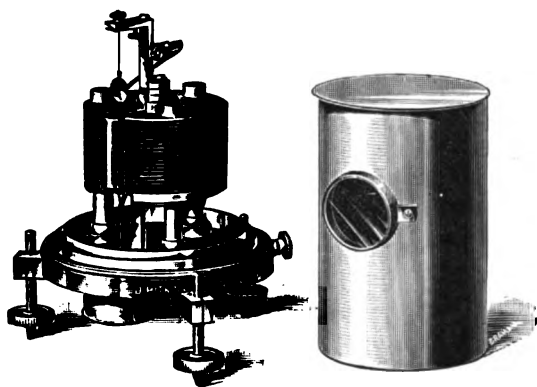

FIG. 3.

installation, and was reserved for ascertaining the temperature of the lead bath for heating test-specimens.

A second instrument was ordered for use at the big furnaces of the oil-hardening and annealing section. Here, on account of the close proximity of the heavy hammers and other ponderous machinery, some difficulty was experienced on the scale of vibration, even though the instrument was placed on a solid pedestal of concrete, the footings of which were several feet below the ground level.

Closely following this second instrument, a further addition was introduced, an instrument of the recording pattern, also made by the same firm (Messrs. James Pitkin & Co.), to the specification of the instrument used by the late Sir W. Roberts-

Austen, and designed for his work at the Mint by Colonel Holden. This instrument, necessitating some slight knowledge of photography—the record being a photographic one—was handed over to the metallurgical laboratory.

With this instrument also some slight trouble was experienced through vibration; but this, after a few experiments, was successfully overcome by suspending the galvanometer

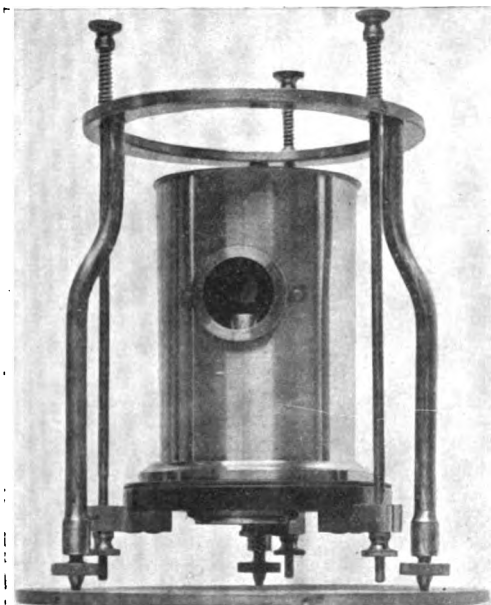

FIG. 4.

from a tripod in such a manner that the vibration was absorbed by three small spiral springs so arranged as to be in partial compression (see Fig. 4).

This method of suspension has proved an admirable one, and has been adopted throughout the system.

Several interesting thermo-metallurgical observations having been made concurrently with the calibration experiments upon this instrument, it was finally decided that it should be permanently retained in the metallurgical laboratory as a standard

instrument available for comparison and for such experimental work as might arise, and that the oil-hardening section should be wired up to the laboratory in order that photographic records of thermal treatment in the mass might be obtained for permanent record as occasion might demand.

These three instruments formed the nucleus of what is now regarded by experts as one of the most complete pyrometric installations in the kingdom.

Fig. 5 conveys an idea of the external appearance of the recording pyrometer, and it may be well described as consisting of two light-tight mahogany cases, the larger of which

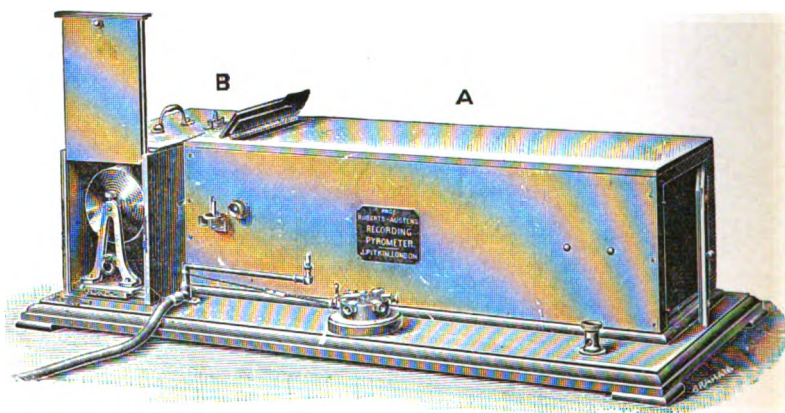

FIG. 5.

(A) contains a Holden-d'Arsonval dead-beat galvanometer similar to that used with the indicating instrument, with a suitable arrangement of lenses, mirrors, &c.

The other case (B) contains a drum which is made to revolve by contained clockwork. The surface of this drum is covered with sensitised photographic paper. A ray of light, from either a gas jet or a lamp, is thrown by means of a mirror, at an angle of 45° , on to the mirror of the galvanometer, and is projected thence to the surface of the drum, and acts photographically on the sensitised paper. The galvanometer is then connected by copper leads to a thermo-junction inserted in the place, the temperature of which it is wished to record.

The heating of the thermo-junction causes a very small current to pass through the coil of the galvanometer which is deflected, and the mirror attached to it projects a spot of light on the surface of the drum.

The amplitude of this deflection indicates the temperature and a continuous curve is traced on the photographic paper, which at once indicates what temperature had been attained at any particular period. A scale is also provided on which

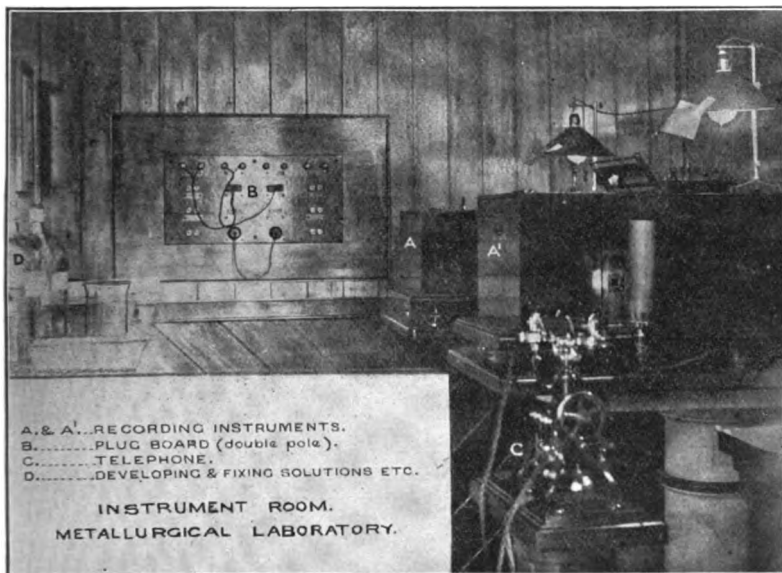

FIG. 6.

the temperatures can be read from time to time without interfering in any way with the record.

Two recording instruments of this type are in constant use day and night, and constitute the laboratory end of the system. These two recorders are also regarded as the standard instruments of the department. They are mounted on simple iron pedestals, the galvanometers being suspended inside the cameras from their respective tripods.

Fig. 6 is reproduced from a photograph of the instrument room attached to the metallurgical laboratory, and shows the

recording pyrometers forming the laboratory portion of the system.

The following branches are now wired up to and are under pyrometric control from the metallurgical laboratory—the heavy forges, the oil-hardening and tempering branches, the case-hardening shop, the drop-forging plant, the lead bath (specimen treatment plant), and the gas muffles throughout the department used by the tool-smiths and other craftsmen (Fig. 9).

The table on next page gives the description and number of the furnaces of each class at present included in the entire system.

The various sections of the gun department are also in direct telephonic communication with the metallurgical laboratory through a small local exchange board.

Each of the larger sections previously named has an independent instrument room fitted with a simple indicating instrument as figured on p. 112.

Fig. 10 is from a photograph of such an office in the forges. These cabins also serve as a storage place for the couples. An attendant is always present whose duties may be summarised as under:—

1. To connect up the respective furnaces, take observations, and communicate temperatures from time to time to the furnace-men or other responsible persons, and also to record all such temperatures in a book supplied for the purpose.
2. To test repeatedly the zero of the instrument in his charge and confirm the readings by telephonic reference at frequent intervals to the standard instruments in the metallurgical laboratory.
3. To report periodically the condition of the couples under his charge, and to keep clean all terminals, connections, &c.
4. To annotate and file the photographic records received from the metallurgical department in order that the record of the thermal treatment of any forging, &c., is at all times available for reference.

The temperature of boiling water is taken as a common zero for the temperature scale of the whole of the instruments comprising the installation.

The testing of the zero of the galvanometer is done almost instantaneously, the same method being adopted throughout the

Section.	Description of Furnace.	Number of Furnaces.	Type of Furnace.	Firing.
Oil-hardening and annealing.	<i>Large Furnaces for Gun Forgings, &c.</i>			
	Circular tube furnaces.	4	Open furnace.	Producer gas.
	Circular jacket furnace.	2	"	"
	Circular annealing furnace.	5	Muffle.	"
	Rectangular annealing furnace.	1	"	"
"	Rectangular heating furnaces.	3	Semi-muffle.	"
"	Rectangular heating furnaces.	3	"	Coal firing.
"	<i>Small Furnaces for Gun Fittings, &c.</i>			
	American rectangular furnaces.	3	"	Illuminating gas.
	American rectangular furnaces.	1	Muffle.	"
	Cyanide hardening bath.	1	Externally heated.	"
	Oil heating baths.	2	"	"
"	<i>For Shrinking Heats.</i>			
"	Cosies.	4	...	Producer gas.
Heavy forges.	Large reheating furnaces.	7	Reverberatory.	Coal firing.
	Smaller reheating furnaces.	3	"	"
	Larger heating furnaces.	3	"	Producer gas.
Drop-forging plant.	Reheating furnaces.	7	Open furnace.	Coke fired.
	Fletcher furnaces.	2	Muffle.	Illuminating gas.
Specimen treatment plant.	Lead baths.	2	Externally heated.	"
	American rectangular furnaces.	2	Semi-muffle.	"
	Fletcher furnaces.	2	Muffle.	"
Tool-smiths.	American rectangular furnaces.	2	Semi-muffle.	"
	Fletcher furnace.	1	Muffle.	"

system. A vessel of boiling water, maintained in a state of ebullition by means of a small gas jet placed underneath,

into which vessel a naked thermo-junction is placed, serves as a simple and ready means of securing a constant reference of known temperature. The glass scale upon which the reading beam is thrown being adjustable to the left or right, a slight movement either way, as may be necessitated, serves to re-establish the zero.

A galvanometer, once installed, may remain for a considerable period without any sensible alteration of the zero. This happy condition results from the effects of vibration being so minimised by the method adopted for the suspension of the galvanometer as a whole, and also in great measure from the fact that the moving coil of the instrument is suspended on a flat wire, as already described, whereby the tendency to zero creep is greatly reduced. Nevertheless, the men are trained to make frequent observations throughout the day, especially when nearing the finishing temperature at which the forging is being treated.

The leads from the pyrometer cabins to the metallurgical laboratory are of Siemens Brothers "T. 5" flexible twin cable carried overhead and supported in similar manner to that ordinarily adopted in telephone wiring.

The instrument room in the metallurgical laboratory is so constructed as to be in itself a dark room in which cameras may be opened, the sensitised bromide paper changed, developed, and fixed. Two recording instruments, a plug board, a telephone, a vessel of boiling water, a bare couple, one or two dishes, and the necessary chemicals for the development and fixing the record constitute the equipment of the office.

The standard instruments are calibrated by the arrest representing the boiling point of water as zero and the freezing points of the following substances:—

Substance.	Degrees C.	Degrees F.
Tin	232	450
Lead	327	621
Zinc	419	786
Aluminium	657	1215
Sodium sulphate	860	1580
Copper	1084	1983

The metals are ordered from the trade as "especially pure for pyrometer calibration," the purity of each parcel being ascertained before use by chemical analysis.

A small crucible charged with about 8 ounces of a metal is placed in a Fletcher injector furnace until the contents are molten, a thermo-couple protected by a small porcelain tube sealed at one end is then placed in the molten metal and the gas and blast turned off. Observations are taken of the cooling of the metal, the temperature of solidification being indicated by the arrest in the downward movement of the beam of light upon the glass scale. From the points thus obtained, an interpolation curve is constructed upon squared paper of ample dimensions. Recalibration, though rarely necessary, is effected in the same manner.

In the construction of the recording instrument the glass observation scale is fixed, so far as lateral movement is concerned, as is also the drum; and the relative position of the movable box containing the drum to the body of the camera is also assured by taper pins in the base board of the instrument fitting in the under portion of the base of the movable box. As, therefore, no adjustment of the observation scale or drum is possible in this pattern of instrument, the adjustment of the zero of the instrument is provided for by means of a tangent screw actuating a pivoted plate upon which is mounted the tripod from which the galvanometer is hung. The slightest turn of the screw at any time serves to re-establish the zero of the instrument, the thermo-junction actuating the galvanometer being immersed in boiling water as previously described.

The sensitised bromide sheet after a twenty-four hours' run on the drum is removed, carefully excluding actinic light, placed in a printing-out frame containing a sheet of plate glass, the inner side of which is painted black and upon which surface longitudinal and vertical lines are scratched, in such manner that upon exposing the frame to active light lines representing both periods of time and temperature are printed. Common flashed ruby-red glass may be substituted for the painted glass, the lines being etched upon the ruby surface by exposure to the action of hydrofluoric acid. The exposed

paper is then developed, fixed, washed, and dried, dated and forwarded to the responsible foreman of the particular section for whom the record is intended. Each sheet represents a day's record in the form of curves of the temperatures of the various forgings treated in the furnaces of the section during the preceding twenty-four hours.

A simple plug board of a double pole pattern is employed, to the back of which the respective leads from each furnace are conducted. These leads are of standard wire, gauge No. 18, of high-conductivity tinned-copper wire, insulated with pure and vulcanised india-rubber, taped and braided. Each pair of leads is enclosed in common gas or steam barrel, which is maintained throughout the whole circuit from the furnaces to the pyrometric cabin of each branch, thus insuring freedom from injury by the corrosive action of any escaping furnace gas or damage by abrasion from ladders, scaffolding, &c., during furnace repairs. The short flexible portion of the leads at each furnace, by which connection is made to the pyrometers in the furnaces, is protected by an asbestos covering, thus preventing any liability of faulty insulation by the scorching of the ordinary coverings. Two plugs suspended on short flexible leads serve to connect either (*a*) the pyrometer cabin, or (*b*) to transmit the thermo-electric current to the recording instrument in the metallurgical laboratory—according to whichever of the two plugs is inserted in the plug holes of the particular leads of the furnace under observation.

B (Fig. 6, p. 117) shows a plug board of this description in the instrument room of the metallurgical laboratory.

The metallurgical laboratory being situated at some distance from the sections previously named, the resistance of the conducting leads is carefully measured, and in calibrating the respective instruments due allowance is made for this. Moreover, with each galvanometer a considerable predetermined series resistance is used, approximating some 500 to 600 ohms, and with such a resistance the slight differences in the lengths of the leads from one furnace to another is not sufficient to impair the accuracy of the readings.

The method of insuring that, as far as possible, the actual

temperature of the article heated is ascertained as distinct from the temperature of the furnace itself, is by sheathing the pyrometer tube in a circular muffle of non-conducting material in such a manner that the extreme end of the pyrometer, which is in close proximity to the couple itself, shall be in actual contact with the articles. The muffle ensures the absence of any false reading due to the temperature of the gaseous atmosphere of the furnace being conducted down to the thermo-couple.

The protecting muffles at present in use are of two distinct patterns. For use at the forge re-heating furnaces, the temperature of which approximates 1100° C. (2000° F.), these muffles are built up of hollow refractory fireclay cylinders or sleeves, similar to those used to protect the swan-neck stopper bar of the ordinary steel casting ladle. These cylinders are luted together and the whole heavily coated with refractory composition, which is then dried and baked. At the furnaces of the oil-hardening section, there being no occasion for long-sustained high temperatures, the protecting muffle is constructed from mild steel tubing varying according to the size of the furnace from 3 to 6 inch bore, and having centering discs placed at regular intervals along the interior to admit of the insertion of an inner tube concentric with the outer one, and of sufficiently large bore to freely admit the insertion of the pyrometer. The annular space between the inner and outer tubes is tightly packed with well-dried asbestos fibre. These muffles vary in length from 3 to 8 feet, as demanded by the nature of the work and the size of the furnace.

As many as five and six thermo-couples are sometimes inserted in the long vertical furnaces of the oil-hardening section employed in heating the larger forgings forming the inner tubes of the heavier guns. These gun tubes in the larger nature of ordnance sometimes exceed 60 feet in length. The furnaces are gas heated, and by means of air ports combustion may be regulated with great uniformity, especially when controlled by a number of thermo-junctions placed at regular ascending intervals in the walls of the furnace.

In this type of vertical furnace the muffles protecting the pyrometer are inserted horizontally through the walls of the furnace, and are of such a length as to extend from the walls to the side of the forging being heated. The muffle is supported at the furnace end in a hollow boss or sleeve clamped on to the forging (Fig. 7) in which the muffle tube fits by a rough bayonet joint, the furnace wall forming the support for the muffle at the exposed end. The pyrometer is then

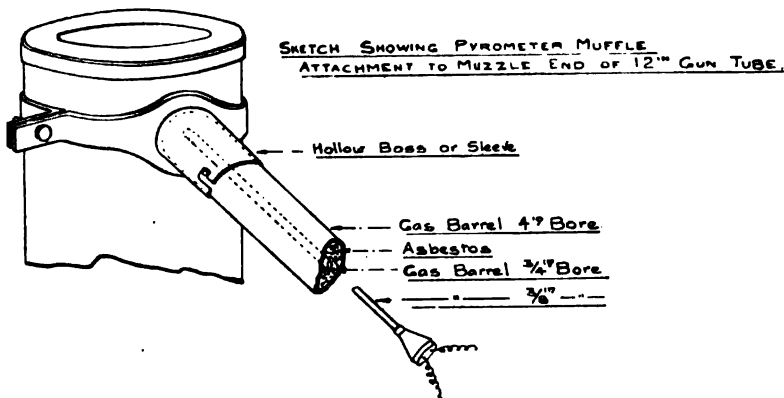

FIG. 7.

inserted in the muffle, care being taken that the extreme end is brought into contact with the forging.

The top stages of the furnaces of the larger description are provided with a simple telephone in communication with the local pyrometer cabin, thus affording no excuse for the furnaceman leaving the stage when nearing the end of the finishing temperature.

Fig. 8 is a reproduction from a photograph of a typical furnace of the above type.

At the forge re-heating furnaces, each of which is fitted with independent leads, the sheathing muffle is introduced through a hole in the crown of the furnace roof, being held up and lowered by means of a small winch connected with a wire rope passing over a simple pulley. Such a

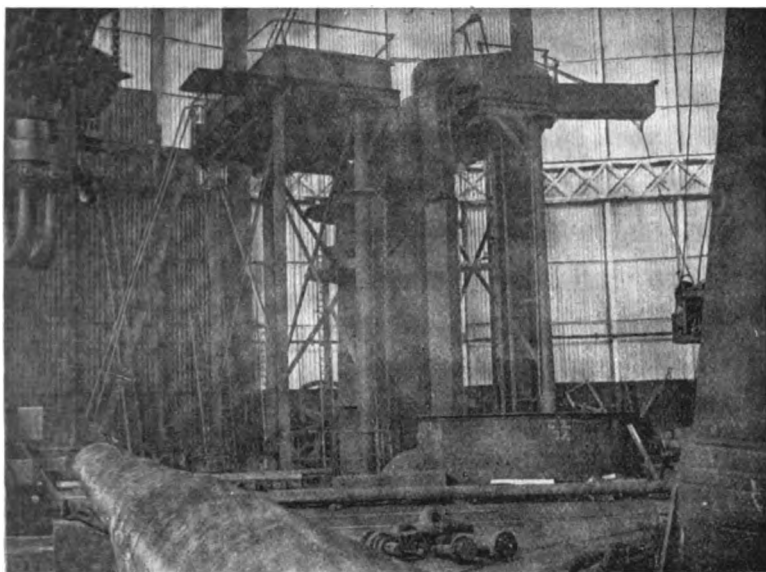

FIG. 8.

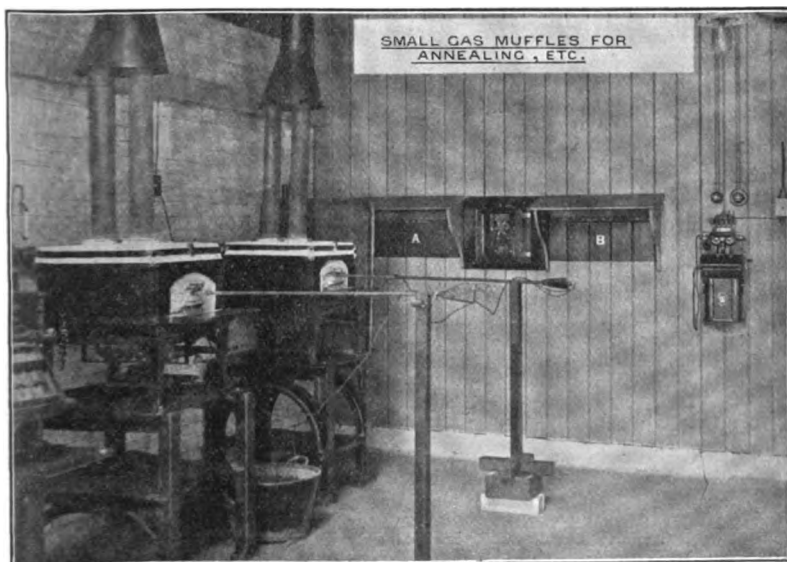

FIG. 9.

muffle is shown suspended over a forge re-heating furnace in Fig. 11.

The billet or forging having been placed in the furnace, the muffle is lowered through the roof, the pyrometer inserted in the muffle, the head of the instrument being well above the crown of the roof and protected from radiated heat by a thick sheet of asbestos millboard.

As far as possible the cold-junction of each couple with the pyrometer leads is maintained at an equable temperature as nearly as possible approximating the normal atmospheric



FIG. 10.

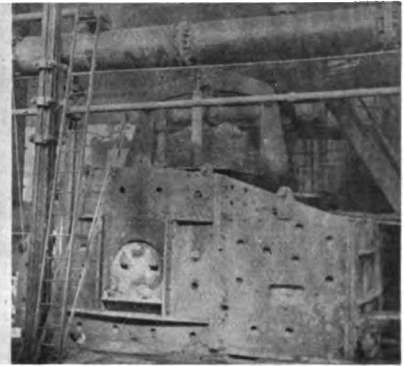

FIG. 11.

temperature; (a) by having sufficiently long pyrometers, the wires of the couple being threaded right through from the hot-junction to the head of the instrument, the latter being protected by asbestos screens wherever found necessary; (b) the further precaution is taken of calibrating the whole system with an allowance for the average cold-junction temperature of the various pyrometers in use throughout the system as ascertained by thermometric observations.

The details of the actual construction of the pyrometers in use are as follows:—

The ends of the couples are twisted together for a length of $\frac{3}{16}$ of an inch; the twisted junction is then "autogene" soldered by holding the ends in the oxyhydrogen flame until

they become fused to a small globule (1, Fig. 12). This method of securing the ends has proved very efficient, as merely twisting the ends results, after repeated heatings of the same couple, in loose contacts, and leads to false readings from time to time according as the contact happens to be good or indifferent.

The unsecured ends of the wires of the couple are then threaded through the double-drilled porcelain tube of highly

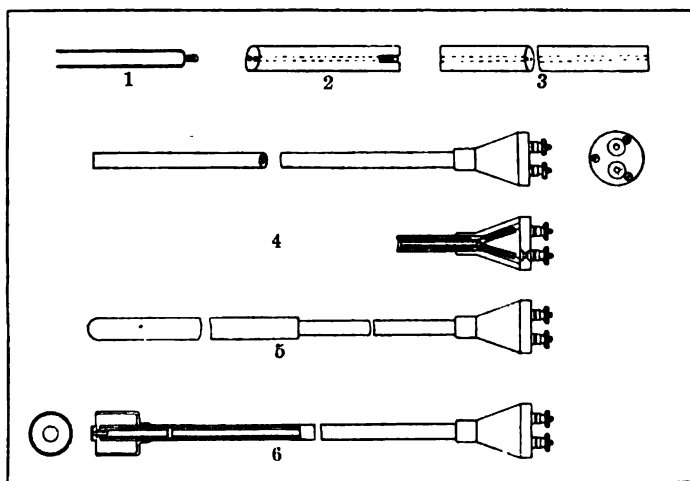

FIG. 12.

refractory clay (3, Fig. 12), care being taken that the wires at each junction of the short lengths of the insulating tubes are not twisted and thereby forming a false contact. This refractory covering, together with the couple wires, are maintained throughout the whole length of a pyrometer, even should this approximate 15 or 16 feet in length, as is actually the case in the longer forms. The wires in the head are wound into two spirals, which are insulated from each other by short lengths of rubber tubing. This affords a few inches of spare wire, use of which is made from time to time as necessitated by the re-making of a new junction, &c. (4, Fig. 12).

The double-drilled fireclay tube, immediately at the junction end of the couple, is sawn through longitudinally for a short distance, just sufficient to little more than cover the end of the junction (2, Fig. 12), and thereby preventing liability of any contact between the couple and the welded end of the iron sheath. The head is of cast metal, bored and tapped to fit the iron sheathing. The cover of the head carries the two terminals to which the wires of the couple are connected to the galvanometer leads. It is made of ebonite, and simply fastened by three screws, as shown in 4, Fig. 12. The iron sheathing is ordinary $\frac{3}{8}$ -inch gas barrel. For use at the lead bath the sheathing is a solid-ended tube bored from mild steel rod, and of such length as to be well above the surface of the molten lead, and joined on to a length of gas barrel sufficiently long to ensure the head being well removed from the source of heat. Welded tubes have not proved satisfactory in use at these baths on account of the lead finding its way through after being in use but a short time (5, Fig. 12). The life of the iron sheathing for ordinary furnace work is considerably prolonged by the use of the muffles already mentioned, which, of course, must obviously protect the pyrometer from the more or less oxidising atmosphere in the furnace.

It is advisable to remove as much scale as possible from the bore of the gas or steam barrel before welding up the end, as any excessive scale on the inside tends at high temperatures to frit with the porcelain insulating tubes, and renders stripping of the couples for repair or examination a difficult task.

The more secure the protection of the wires of the couple from the influence of the furnace gases, the more immune to changes in thermal value is the wire itself. Upon exposure at long-sustained high temperatures more or less crystallinity of the platinum and iridio-platinum wires takes place. Neither the thermo-electric value nor the conductivity is materially affected by slight changes of this nature.

Excessive crystallinity, however, renders the wire brittle, and necessitates careful handling and frequent inspection when this occurs. The pyrometer should be temporarily withdrawn

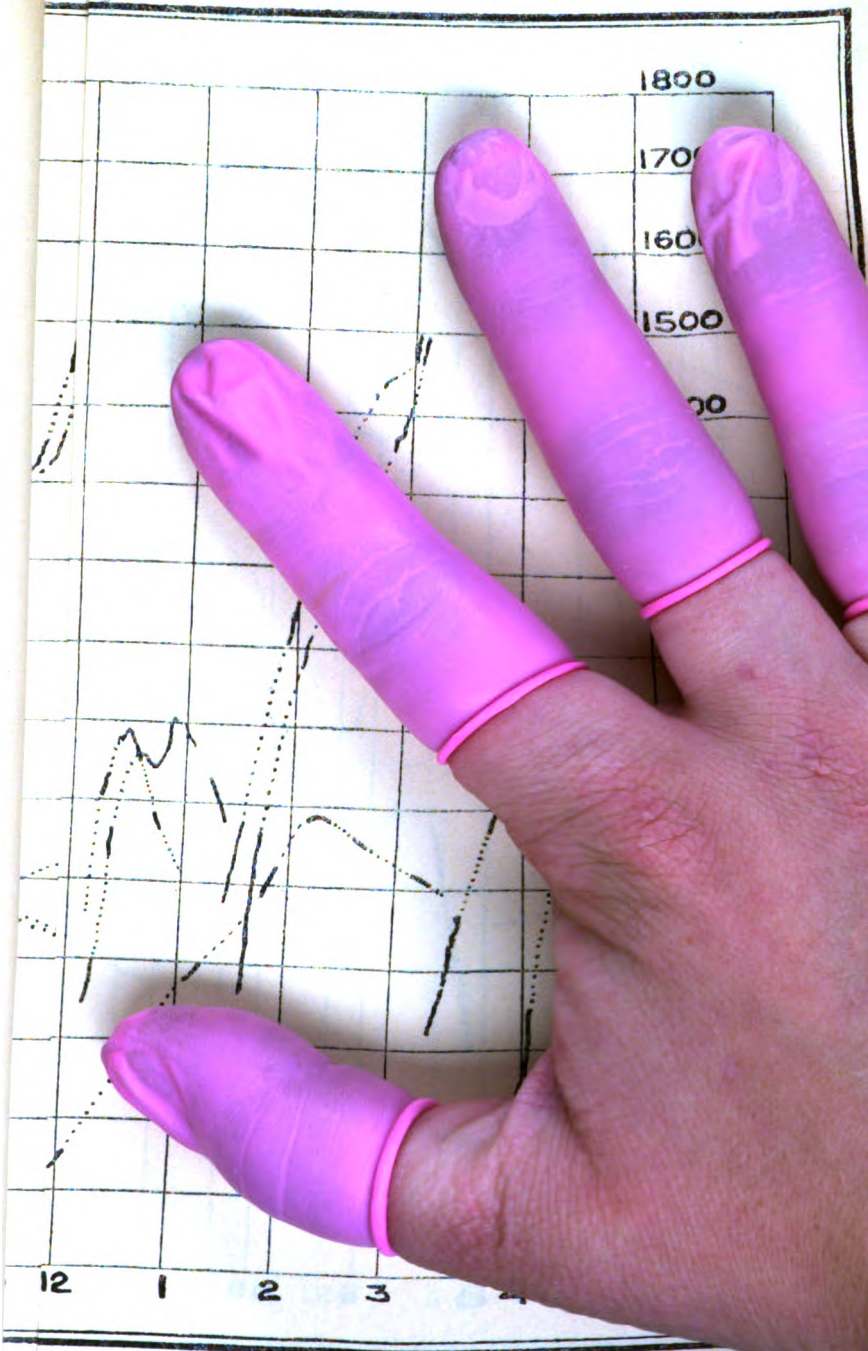

from use and the couple stripped. The malleability of the wire may be restored by momentarily glowing to incandescence. This is best done by passing a heavy current of electricity through the wire. If this is not convenient, the brittle portion of the wire may be cut off and the wires pulled down from the head, for which purpose the spirally coiled length at the end of the wire is provided, or failing sufficient length to allow of shortening the wire the whole couple may be transferred end for end.

The gauge of the platinum and the iridio-platinum wires employed throughout the installation in making up the couples is of a uniform size, viz. 25 standard wire gauge, and it was found of considerable advantage to secure a sufficiency of the wires in single coils for the whole installation, with a considerable reserve for the upkeep of the same and for any additional extension of the system that might be necessitated in the near future.

The advantage in securing a single coil of each of the wires is evident. It favours the chances of the metals being of the same composition throughout and of the same thermo-electric value, which is more than one can hope for in buying short lengths from time to time. Too much care, however, cannot be expended in satisfying oneself that each couple made up is practically of the same thermo-electric value, as otherwise the calibration of the instruments does not hold good for the whole of the pyrometers throughout the system.

The variableness of the coil of wire may be tested on its receipt by cutting off portions from each end of a coil, twisting the ends of the *similar* metals together, and connecting the free ends to the galvanometer. On applying heat to the junction no appreciable movement on the galvanometer scale should be observable, thus demonstrating the purity or uniform composition of the wire.

There still remains a form of pyrometer which is in daily use for ascertaining shrinkage temperatures in the building up of ordnance, &c., and also for ascertaining the given temperature below which it is not deemed desirable to put further work upon a forging. This couple is similar in most respects to those previously described, but differs in one important feature.

The fire end of the couple terminates in a small exposed platinum plate made up of two small circular discs, $\frac{5}{16}$ of an inch in diameter, of sheet platinum, between which the wires of the couple are lead, and the two discs secured by riveting each to the other. This small plate or disc standing proud of the end of the pyrometer is supported some distance from the end of the tube by a small spiral spring, thus ensuring a good contact when the couple is pressed to the face or side of the heated body. The platinum plate serves as a collecting disc, and being very light and small almost instantly acquires the temperature of the heated mass, and being itself the actual hot-junction proves a most efficient thermo-couple. The general construction of this form of pyrometer will readily be understood by reference to 6, Fig. 12.

In conclusion, the author, not deeming such a paper complete without the addition of a typical daily record as furnished by the laboratory recording instrument, has solicited special permission, which was readily accorded, to include a specimen sheet.

Plate VI. is a reproduction of such a record, and, as will be apparent upon close inspection, represents in some cases curves of the heating of gun forgings for the oil-quenching process, and in others the annealing of gun forgings. These records, as previously stated, are forwarded to the responsible foreman of the section to be critically examined and annotated and filed for easy reference.

APPENDIX.

In the thermal treatment of steel for ordnance much of the latter-day success has been attained by the systematic use of the pyrometer as a means of controlling the actual temperatures during any part of the process, and also from the knowledge obtained by a determination of the critical temperatures of any particular steel.

The method adopted in the Royal Gun Factory for the determining of the range of these latter is that of plotting differential heating and cooling curves after the manner employed by Carpenter and Keeling at the National Physical Laboratory,* and only differing from the method described by these two investigators in that no potentiometer is used, the readings being taken direct from an open scale.

Fig. 13 is from a photograph of the installation in the

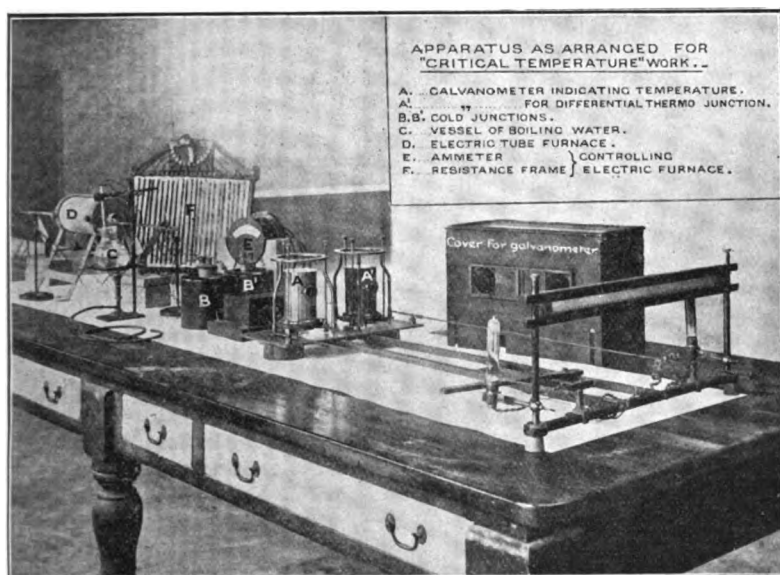

FIG. 13.

metallurgical laboratory as arranged for critical temperature determinations. These critical range determinations, the examination both chemical and microscopical, together with the somewhat elaborate mechanical tests of the present day, and also the pyrometric control during mass treatment, tend, it must be admitted, to raise the thermal treatment of ordnance steel to a higher scientific level.

* *Journal of the Iron and Steel Institute*, 1904, No. I. p. 224.

DISCUSSION.

Sir THOMAS WRIGHTSON, Bart. (Thornaby-on-Tees), said he had had some experience with the pyrometer of Sir William Roberts-Austen, as they had made experiments together at the Mint with that instrument with regard to the decrease of temperature on pressing together two pieces of steel or iron at their welding temperature. Their object was to show that iron possessed the same property that ice did, and that upon pressing two surfaces together the temperature would be lowered. It was only in that way that he came in contact with that particular subject, and he was very much interested in the very complete installation which Sir W. Roberts-Austen had at the Mint, and which he was allowed to use in the experiments, the results of which he had had the honour of communicating to the *Transactions of the Royal Society*.

Mr. W. ROSENHAIN (National Physical Laboratory) wished to raise one or two points in connection with Mr. Lambert's interesting account of the very complete pyrometric installation at Woolwich. The first was that apparently all the measurements of temperature were made by deflection methods. These methods were very valuable and convenient, especially for recording purposes where the more accurate potentiometer methods were not available. But all deflection methods were liable to serious errors on account of zero-creep in the D'Arsonval galvanometers. That became particularly serious in the apparatus described in the paper. Mr. Le Chatelier and Mr. Saladin had devised an ingenious autographic apparatus for recording differential cooling curves, but this also suffered seriously from zero-creep. For such purposes he (Mr. Rosenhain) suggested the use of a delicate bifilar galvanometer, such as Campbell's, which was free from this source of error. Where delicate D'Arsonval galvanometers were used, be it with lamp and scale or a direct-reading pointer, zero errors must be carefully guarded against. The only other point he wished to raise concerned the protection of the thermo-couple from furnace gases. Mr. Lambert endeavoured to do that, but even with his precautions the wires evidently became brittle in time. He (Mr. Rosenhain) doubted whether mere heating to incandescence, electrically or otherwise, would cure this defect once it had been set up. When perfectly protected from furnace gases the indications of thermo-couples were found to remain remarkably constant, but, failing that, great caution was required.

Mr. J. M. GLEDHILL, Member of Council, said he did not think there was any more important subject which had been brought before the Institute than that of pyrometry. It was probably now quite as important as anything in connection with the manufacture of steel for heavy gun forgings, ordnance, or anything connected with war *materiel* in the way of steel, and he might briefly say why. The

Government tests for ordnance were very rigid and very severe, and practically no latitude was allowed. Manufacturers had to adhere strictly to the letter, and in order to do so it was necessary to understand heat treatment, and obtain the accurate heat treatment according to the chemical composition of any particular steel that was being treated, and that could only be done by such an installation as the paper treated of. He might say that all who were engaged and interested in the manufacture of ordnance were greatly indebted to the Royal Gun Factories through the courtesy of Colonel Holden, the superintendent, for the permission he had granted them to inspect this experimental scientific installation of pyrometers now at Woolwich Arsenal, and which had been carried out by the colonel. Having got pyrometers of an efficient kind, such as described in the paper, there was still another important matter, and that was the using of them. They might, and indeed did, know what heat was wanted to get, say, in a gun forging of some 50 to 60 feet long for a 12-inch gun, and weighing probably 30 tons. They knew what temperature they wanted, but the getting of it to an equal degree of temperature throughout was another matter. Then again the tensile tests, the elastic limit, the ultimate breaking stress, the elongation, must be the same in the breech of the tube as at the muzzle, so that they had got another difficulty there. The chemical composition of the two ends of that forging were not identical. That was owing to segregation; the carbon constituents at the one end of such a forging were quite different to the constituents at the opposite end, so that quite a different temperature was required. Although he spoke of quite a different temperature, he was in reality only referring to probably 20° or 30°, because in alloyed steel containing nickel or chromium, or elements of that nature, the question of small differences of temperature was of the utmost importance. So that they had a different chemical composition to deal with; they again had a different mass, the muzzle end of the barrel might be, roughly, say, 2 inches thick, whereas the breech end was 6 or 7 inches thick. They had therefore got different degrees of temperature, and different conditions, different thicknesses, different masses, and different carbon constituents, all of which require to be watched by the pyrometers so as to get an equal ultimate result from the tests. That was a matter that could only be arrived at by constant and daily experience. It would be absolutely impossible to work on the old lines as they used to do years ago when they judged temperature by colour, when they spoke of blood red, or pale straw, or similar states. Such distinctions were absolutely utterly useless at the present time. They required an installation of the kind described, and even then it required great skill to meet the Government requirements. He had himself found that a very good practical check in the hands of workmen over the more scientific instrument was the use of the Siemens water pyrometer, where a ball of known weight was put in contact with the article to be treated and covered over with sand so as to protect it from the action of the flame of the furnace, and after a given time

withdrawn and inserted in a known volume of water. By such means a very accurate reading could be obtained even by a workman. The system described by Mr. Lambert was an accurate and definite result of what was actually going on in the furnace, and was recorded as described, so that it was always possible to look at any particular forging, and if anything happened to a gun it was possible to refer back and see how the treatment of the forging had been carried out, what its temperature had been, and what its history was. He desired once again to thank Colonel Holden for the permission he had given to view the excellent installation at Woolwich.

Dr. CARL BENEDICKS (Upsala) asked if there was any arrangement made for controlling the temperature of the cold junction. On the curves given it was easy to read off the temperatures within a very few degrees, and of course the temperature of a cold junction was known to have a very great influence in that respect, so he supposed that there must be something done, although he had not been able to find any mention of it in going through the paper.

Mr. W. H. HATFIELD (Sheffield) drew attention to the difficulty he thought all workers had experienced with thermo-couple pyrometers. In many works in Sheffield a portable pyrometer of this type was in use. It was easy, of course, to calibrate the instrument, but the trouble arose from the kind of casing used for enclosing the wires of the couple. Makers would continually supply couples enclosed in silica to work with the same galvanometer as those enclosed in iron without advising the user of the differences in the readings given. He had found a silica-covered tube to give as much as 50° higher reading than an iron-covered one by the same maker. It was the conductivity of the iron tube which caused the trouble, and he was pleased to see that the author had taken effective measures to prevent this inaccuracy.

Professor THOMAS TURNER (Birmingham University) said he had used a direct reading pyrometer for some years and found it very convenient for many purposes, but there was one difficulty in connection with the direct reading of pyrometers. There was always a variation on putting a new couple in. But practically what they had to do was to calibrate the instrument from time to time, and not to take the actual readings, but to draw a chart and to take the figures read on the instrument on one side, and the figures of the observation read on another, and draw a curve. That had to be done every now and then, so that even direct instruments, unless they actually went back to the makers to be checked occasionally, were apt to give results that were not quite accurate. If it were required to use a couple, sometimes bare, and sometimes covered with one thing and sometimes with another, it was necessary to calibrate the couple under exactly the same conditions as those under which it was going to be used.

The PRESIDENT said he was sorry Mr. Wesley Lambert was not present so that they might have had the opportunity of hearing him on the various points which had been raised in connection with his paper. He invited the meeting to pass their thanks to Mr. Wesley Lambert for his excellent paper.

The resolution was carried by acclamation.

CORRESPONDENCE.

Mr. E. F. LAW (London) wrote that, while fully appreciating the value of Mr. Lambert's paper, he desired to draw attention to a statement which was certainly misleading and liable to cause misunderstanding in the minds of those who were unacquainted with the facts. He referred to the statement that the recording pyrometer introduced into the Gun Factory at Woolwich was made "to the specification of the instrument used by the late Sir W. Roberts-Austen, and designed for his work at the Mint by Colonel Holden." From that description any one unacquainted with the history of pyrometry might be reasonably excused for supposing that Colonel Holden was the originator of the recording pyrometer used by Roberts-Austen in his classical researches at the Royal Mint. That, of course, was not the case. Briefly the facts were as follows:—In 1889 Roberts-Austen first used the platinum thermo-electric pyrometer of Le Chatelier, and in the first report to the Alloys Research Committee on the 29th of October 1891, he stated: "Le Chatelier's pyrometer, I believe, had not previously been employed in this country; and it may be well to describe it in some detail, as such an instrument has long been needed, and can hardly fail to be of much use to engineers." He then went on to describe his own recording arrangement, the actual model of which was made at the Mint by Mr. H. C. Jenkins, who was at that time his assistant. In the second report to the Alloys Research Committee, Roberts-Austen said, with reference to the recording pyrometer: "This instrument was described in the first Report to the Committee; but as the investigations progressed it soon became evident that the construction of many of the details could be greatly improved; and, in order that a more perfect instrument might not be wanting, the appliance, of which the following is a description, was made at the Royal Mint by artificers from the Royal Arsenal, Woolwich, who were permitted by Dr. Anderson, Director-General of Ordnance Factories, to undertake its construction for use in his department." The pyrometer in question was further modified, and the instrument used in the later researches and described in the Fifth Report was mainly due to Dr. Stansfield, now Professor of Metallurgy at the McGill University.

Incidentally it might be pointed out that the recording instrument described by Mr. Lambert in his paper was that made and sold as the "Works Model," and not one of the forms of "Research" pyrometer as used at the Mint.

Mr. WESLEY LAMBERT wrote, in reply, that he shared with the President his regret at not having been present to reply to the various points raised. In reply to the points raised by Mr. W. Rosenhain, he wished to confirm that gentleman's assumption that all the temperature readings taken throughout the installation were by the deflection method. The objection to that method on account of zero-creep, though admitted, was not of such serious moment as had been suggested. It did not present any practicable difficulty in the installation described, and was only an appreciable quantity when large deflection, tight wires, and not strip, were used. The occasional checking of the zero was the only precaution necessary. The potentiometer method, Mr. Rosenhain would doubtless readily admit, was not a practicable workshop method. With reference to the second point as to the brittleness of the wires forming the couple, he desired to offer the suggestion that the National Physical Laboratory might make the protection of thermo-couples for furnace work a subject of extended research. The remarks of Mr. Gledhill were very gratifying, the more so as he was particularly conversant with the actual conditions necessitating such an installation as described in the paper. Excellent results had also been obtained in the Royal Gun Factory, using a platinum cylinder, with the Siemens water pyrometer when used in comparison with the thermo-junction. He would refer Dr. Benedicks to that part of the paper dealing with the arrangements for insuring the cold junctions being protected from changes in temperature. For critical work in the laboratory, the recognised methods of controlling the temperature of the cold junction were resorted to. He (Mr. Lambert) extended his sympathies to those workers with pyrometers mentioned by Mr. Hatfield. One of the greatest mistakes made by users of pyrometers generally was the neglect to make themselves acquainted with the details of the construction of the pyrometer they were using, and its limitations for accurate work under varying conditions. As regards Professor Turner's remarks, they had had a considerable quantity of the wire drawn at one time, and so as far as possible eliminated variations due to the slight differences in the metals forming the couples. The concluding remark of Professor Turner was fully endorsed by actual experience whenever accurate readings were desired. The statement to which Mr. Law took exception applied only to the instrument described in the paper, and was not intended to apply to any other instrument.

UTILISATION OF BLAST-FURNACE SLAG.

BY THE CHEVALIER C. DE SCHWARZ (LIÉGE).

TAKING the total production at all blast-furnace works in the world, according to recent statistics, at about 50,000,000 tons of blast-furnace slag for the last year, and assuming further that 1 ton of ungranulated blast-furnace slag measures, when broken up, about 20 cubic feet, the blast-furnace slag produced in one year represents a mountain of nearly 1,000,000,000 cubic feet. To dispose of such enormous masses yearly deserves serious consideration, taking into account that the production of pig iron, and with it also that of slag, is steadily increasing, and that the land in the neighbourhood of blast-furnaces is, as a rule, of great value.

John Payne, an Englishman, was the first who succeeded in utilising blast-furnace slag for making big solid blocks—up to 3 tons in weight—which were successfully used for making river and canal embankments.

According to his method of making blocks, patented in the year 1728, the liquid slag was first thoroughly worked through, by means of a shovel, in order to allow any air or gas bubbles to escape, whilst, at the same time, sand or crushed slag was added. The doughy mass thus received was pressed into cast-iron moulds lined with sand. When hard, the blocks were withdrawn from the moulds and allowed to cool down slowly in a bed of sand mixed with charcoal dust.

This method of making blocks could, however, only be used for utilising blast-furnace slag high in silica and poor in lime, *i.e.* principally for slag resulting from blast-furnaces worked with charcoal, for reasons not necessary to be explained.

Fritz Lürmann, when at Osnabrück, was the first who recognised and also utilised the hydraulic properties of granulated basic blast-furnace slag for making bricks by mixing

granulated blast-furnace slag with lime-cream and pressing this mixture into moulds. The lime thus combining with the free silica in the granulated slag served as a cement, and the bricks became hard on free exposure to the atmosphere within about six to eight weeks. The slag bricks produced at the beginning were, however, of inferior quality, and could, on account of their insufficient strength, only be used for masonry of minor importance.

It was also found that, during the time of hardening, a good many bricks cracked and fell to pieces.

Considerable improvements were made later on, namely—

a. An automatic feeding apparatus was provided, having for its purpose the maintenance of the proper proportions between the granulated slag and the slaked lime, ascertained by experiment, instead of leaving these proportions to be adjusted, as before, by the workmen employed. In general it was found out that an addition of 150 lbs. of dry slaked lime to 850 lbs. of granulated slag, containing on an average 20 per cent. of water, answered the purpose pretty well. ...

b. Appliances were employed, by means of which an intimate mixture between the slaked lime and the granulated slag was obtained.

c. A press, especially constructed for making slag bricks, was employed. In the first instance the maximum pressure was raised to about 3500 lbs. per square inch. Secondly, the press was constructed in such a way as to do its work with a gradually increasing pressure, instead of, as before, by means of a heavy shock. The latter had a double advantage: firstly, the high pressure was transmitted up to the very interior of the brick, which was not the case when the press worked with a shock; and secondly, all superfluous moisture was squeezed out.

d. In order to avoid, as much as possible, any loss from bricks bursting, on account of small particles of unslaked lime being entangled and inclosed in the interior of the brick, the slaked lime had, before use, to pass through a ball mill, where it was reduced to fine powder and intimately mixed, whereby a complete conversion of any free lime into hydrate of lime was ensured.

One such press with its accessories, as mentioned before, produces about 2000 slag bricks per hour, the whole requiring about 25 horse-power to drive it.

One slag brick of ordinary size, manufactured in the way described, weighs on an average 8 lbs., and has a maximum crushing strength of 1700 lbs. per square inch. The working expenses (lime, wages, repairs, and motive power) are stated to be about 8s. per 1000 bricks of ordinary size.

A brick press, also constructed for making slag bricks, was recently invented by Paul Thomann in Germany. The peculiarity of this press consists of an improved mixing apparatus, of special construction, for mixing slaked lime and granulated slag, as well as in a peculiar method of pressing the bricks. The process is as follows:—

Slaked lime and granulated slag coming from an automatic feeder are led to the mixing apparatus by means of a band conveyor. The mixing apparatus consists of a small cylindrical sheet-iron vessel containing a mixer with screw-like arms of peculiar shape, in which the materials are, owing to quick rotation, intimately mixed within a short time.

The mixture of sand and slaked lime thus produced falls, by means of a hopper, into the brick press. The peculiarity of the latter consists in an arrangement by means of which the brick is formed in layers, each layer being hammered down separately, one above the other, until the brick mould is filled up. This arrangement has the advantage of cheaper working expenses and less initial outlay. The bricks produced with this machine are also less heavy and have a rough surface, the latter being preferred by the masons.

Another method of making slag bricks, still in use, consists in mixing one part of Portland cement with from four to five parts of granulated slag and pressing this mixture into moulds. These bricks must remain in the mould for twenty-four to thirty hours after being pressed. As they are not allowed to harden in the open they have to remain, after having been taken out from the mould, for six to eight weeks in a covered shed, well protected against sun and wind, where they are moistened from time to time.

The bricks produced in this way are of very good quality,

but their cost of manufacture is very high, requiring also a considerably high initial outlay; it can therefore only be recommended for making artificial stones of special size, staircase steps, slabs, &c.

The best slag bricks, so far as exact shape and dimensions as well as great hardness and resistance to crushing are concerned, are manufactured according to the English method.

According to this process blast-furnace slag can be made into bricks or stones without any addition of cement, slaked lime, or any binding medium. It is based on the fact that insoluble silica is rendered soluble, *i.e.* ready for combination, if exposed to high steam pressure during a certain lapse of time. A full description of this method of making slag bricks is already given in the *Journal of the West of Scotland Iron and Steel Institute* for 1904.

The bricks, manufactured according to this process, can be transported to their destination and used for masonry as soon as they have left the hardening chamber, described in the above paper. For this method of manufacturing bricks blast-furnace slag from the old slag heaps, even if exposed to free air for several years, can be utilised.

The cost of producing 1000 bricks of ordinary size, according to the English process, described before, is stated to be 13s.

Slag bricks have the following advantages over ordinary baked clay bricks:—

- (a) They have a considerably higher resistance against crushing.
- (b) Houses built with slag bricks are never damp, and can be occupied without danger to health as soon as they are built.
- (c) Slag bricks are more accurate in shape and dimensions, because they are not baked, and therefore do not shrink like clay bricks.

For certain purposes slag bricks, manufactured according to the English process, as described before, are, on account of their accurate shape and extreme hardness, preferred even to natural stone; for instance, in Brussels such bricks are used

for the facing of walls for houses (*Verblendsteine*), and paid for at the rate of 60 francs (48s.) a thousand. For ordinary masonry, slag bricks manufactured according to the other methods, already described, are used because they are considerably cheaper.

Cement.—Of considerably more importance than the manufacture of slag bricks and stones, with reference to the utilisation of slag, is the manufacture of cement. This is principally due to the fact that cement, weight for weight, sells at a rate which is about four times as high as that of bricks.

The subject of the utilisation of blast-furnace slag for making cement has already been treated in detail in the author's previous papers, read before this Institute in 1900 and 1903, and before the International Congress of Mining and Metallurgy at Liège in 1905, to which he would refer.

Since then the same question has been treated by several authorities, such as Dr. Passow, Le Chatelier, Wedding, Blount, Thwaite, Day, A. Sheperd, Tantzen, Jesser, Baron Jüptner, Ast, Linge, Hofer, Struthers, Zulkowsky, and others, who have written about it in different professional papers and pamphlets. The author cannot quite agree in some cases with the statements made. For instance, it has been repeatedly stated that no cement can be made from slag resulting from the manufacture of white pig iron. This is incorrect, as may be proved by the fact that Portland cement of good quality can be made from such slag, containing 42 per cent. of lime and $4\frac{1}{2}$ per cent. of oxide of manganese. The cement made from such slag showed not the slightest trace of instability of volume even after six years' use; it also stood all the tests required by the standards for Portland cement. The manganese oxide in the cement gave it a somewhat brownish colour, which, however, was not considered a fault by some customers, but on the contrary was preferred to the ordinary tint for making artificial stones.

To a certain extent the presence of metal oxides, such as those of iron and manganese, which, as a rule, are higher in slag from white pig iron, makes the cement made from it more apt to resist the influences of sea water, as already mentioned in previous papers. Secondly, the presence of metallic oxides reduces the temperature of fritting, necessary for the formation

of clinker, thus effecting saving in fuel as a consequence. As the majority of blast-furnace slag produced nowadays results from white Thomas pig, it may be considered advisable to draw attention to this fact, as hitherto the general belief was that only slag resulting from grey pig can be used for making cement on account of its higher percentage of lime and its small percentage of manganese oxide. It has been proved that a high percentage of lime in Portland cement is not only not necessary, but is to a certain extent even injurious, as, being to a certain extent free, it causes the cement to "blow." Therefore such cement, rich in lime, must, as every experienced cement maker knows, be kept for some time in a cement silo before being ready for use, in order to give it time and opportunity to absorb carbonic acid and water from the air for the purpose of converting the free lime it contains into carbonate of lime and into hydrate of lime respectively. Experience has also shown that cement, rich in lime, cannot be used advantageously for buildings in sea water.

A new process of making cement from blast-furnace slag has been invented by Professor Mathesius at Charlottenburg. This process is based on the principle, already referred to, that insoluble combined silica can be turned into the soluble, combinable state by exposure to high steam pressure. The process is described as follows: The blast-furnace slag is allowed to cool down, when it is put into boilers, where it is exposed to steam pressure until it is reduced to powder. Results of experiments have proved that slag, thus treated, had acquired hydraulic properties, but nothing has been done as yet to start works on a commercial scale.

Mr. Renfert, starting on the same principle, took out a patent according to which granulated blast-furnace slag was treated with steam, but subsequently mixed with lime. This mixture being ground to a very fine powder, yields a cement of very superior quality. Notwithstanding, after experimenting for some time, the inventor abandoned his process on account of too high working expenses.

Mr. Canaris invented a process according to which hot liquid blast-furnace slag, containing not less than 40 per cent. of basic matter, is cooled down suddenly by mixing it

with thin lime-cream. The product thus received is then ground into powder, and after that supposed to be cement. This process has some resemblance to the Wolff and Lessing process, already described in my paper read before this Institute in 1903. Neither the Canaris process nor that of Wolff and Lessing have found their way into practice, and will hardly ever do so.

Timm, Hayn, and others have invented different arrangements for granulating slag without water, but, none of them having been carried out in practice, no opinion can be given about them.

Of all the processes of making cement from blast-furnace slag invented recently, it appears that only one of them has as yet been accompanied with success, namely, the Colloseus process, called so after the name of the inventor.

According to this process, solutions of alkaline salts are injected into the hot liquid slag and thus intimately mixed with the latter, the nature and concentration of the injected solutions depending on the chemical composition of the slag, principally on its contents of lime. The quantity of the solution to be injected should be as high as possible; however, the slag thus treated must be perfectly dry after the operation. The salts used for preparing the solutions are principally alum, sulphate of magnesia, and nitrate of lime. The concentration, as a rule, varies from 2 to 5 per cent. of salt to from 95 to 98 per cent. of water.

On account of the great heat the salts are decomposed, most of the sulphur escaping as sulphurous acid and sulphuretted hydrogen. The slag is chemically and physically changed, and gets the appearance of a porous clinker easily broken up and reduced to powder.

In case slag with a comparatively high percentage of silica and a lower percentage of lime is to be converted into cement, the concentration of the alkaline solution is raised to a maximum of 10 per cent. of the salt to 90 per cent. of water; besides this a small addition of common cement-clinker, rich in lime, has been found beneficial in such cases.

At the beginning the Colloseus process did not prove successful, principally on account of defective construction

of the granulating apparatus, which did not allow of an intimate mixture between the solutions and the slag. At the same time the selection of the blast-furnace where the first apparatus was put up was not a very fortunate one, as it suffered continually on account of interruptions; besides this there was not sufficient space and other inconveniences.

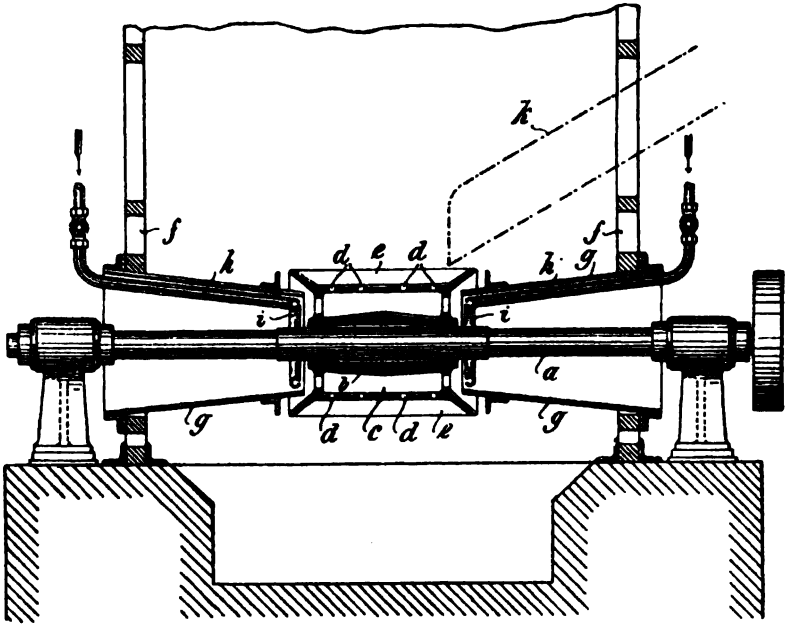

FIG. 1.

Under these circumstances it was impossible to produce cement of a satisfactory or regular quality.

Lately, however, these defects have been overcome by employing an improved apparatus, which the following description and drawings will serve to explain.

Fig. 1 represents a longitudinal and Fig. 2 a cross-section of the apparatus. The drum *b* fixed on the shaft *a* is divided into six interior partitions by means of cast-iron ribs *c*. On the outside the drum is provided with a number of other radial ribs *e*, running, like the former, parallel with the shaft *a*.

Between the ribs *e* a number of longitudinal openings *d* are arranged to provide communication between the interior and the outside of the drum, the latter revolving at the rate of about 650 revolutions per minute. On this drum the hot liquid slag, coming from the blast-furnace, is led by means of a channel *k*, the whole apparatus being enclosed by a chamber or casing *f*, made of sheet iron and cooled with water from outside.

Two funnels *g* (Fig. 1) fixed on the casing *f* contain the tubes *h*, the latter leading the alkaline solutions to the revol-

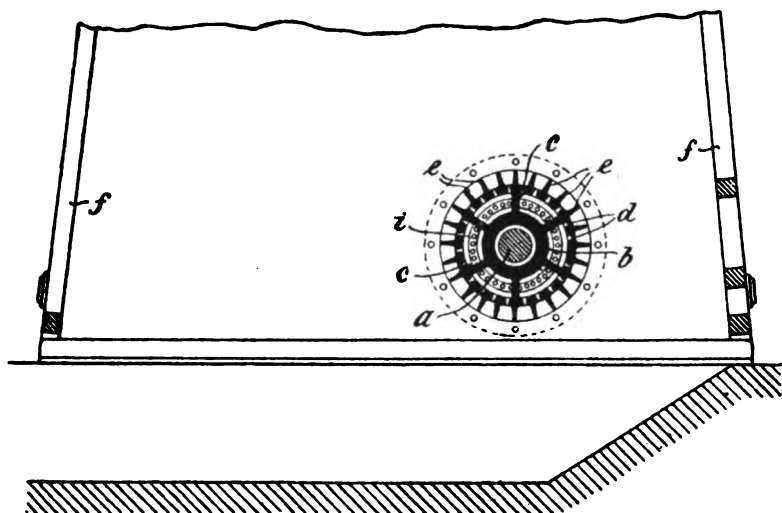

FIG. 2.

ing drums. At the same time through these funnels cool air is sucked into the interior of the drum along with the alkaline solutions and, the quick revolving drum acting like an exhauster, thrown out together through the openings *d* with a certain force. In order to ensure a proper distribution for the entrance of the solutions into the interior of the tambour, two ring tubes *i* (Figs. 1 and 2) perforated with little holes (shown in Fig. 2) are provided.

The slag, being thus intimately mixed with the alkaline solution, is hurled with great force against the casing *f*, from where it falls by means of an incline into little bogies to be

transported to the crushing-mills. From this description it may be seen that the working expenses for making cement from blast-furnace slag according to this process must be exceedingly low, and the initial outlay for erecting such cement works very moderate, as the drying and grinding of raw materials, as well as brick-making and the burning of clinker, is avoided.

As to the quality of this cement, it may be said that, according to information received, it has stood all the tests prescribed for Portland cement by English, French, and German authorities. The cement has been employed for about a year in the erection of viaducts, railway embankments, bridges, houses, &c., showing, up to date, not the slightest trace of damage.

It had several times been pointed out as a drawback to the utilisation of blast-furnace slag that the latter is more difficult to grind than natural raw materials. This reproach is, up to a certain extent, justified, although this difficulty is already largely overcome by granulating the slag, whereby the latter, being cooled down very suddenly, becomes exceedingly brittle.

In addition to this, crushing-mills have been recently invented specially well adapted for grinding slag, and have proved a great success in practice. The ball-mill with air-separator invented by Mumford & Moodie, and made by the Brothers Pfeiffer at Kaiserslautern in Germany, affords an instance of such a mill.

The following is a description of this apparatus: Fig. 3 represents a vertical section through the air-separator, the latter representing, as it were, the backbone of the whole arrangement; *g* is an exhauster, fixed, like the two discs *b* and *d*, on the quickly revolving vertical shaft *a*. The ground material (raw meal or cement) coming from the ball-mill drops into the funnel *f*, and from there on to the disc *b*, from where, by means of centrifugal power, it is hurled against the ring *c*. From there it falls on a second disc *d*, the latter being of greater diameter than the former. From this disc, again, the material is hurled towards the ring *e*. This arrangement has for its prime purpose to distribute the material as much as possible in the air enclosed by the rings *c* and *e*. Through

the ring *e*, which is open below, the air is sucked on by the exhaustor *g*, and enters the interior of the two rings *c* and *e*, as shown by arrows, taking the fine, finished material along with it, which, after having passed through the exhaustor *g*, enters the chamber closed in by the outer casing and drops,

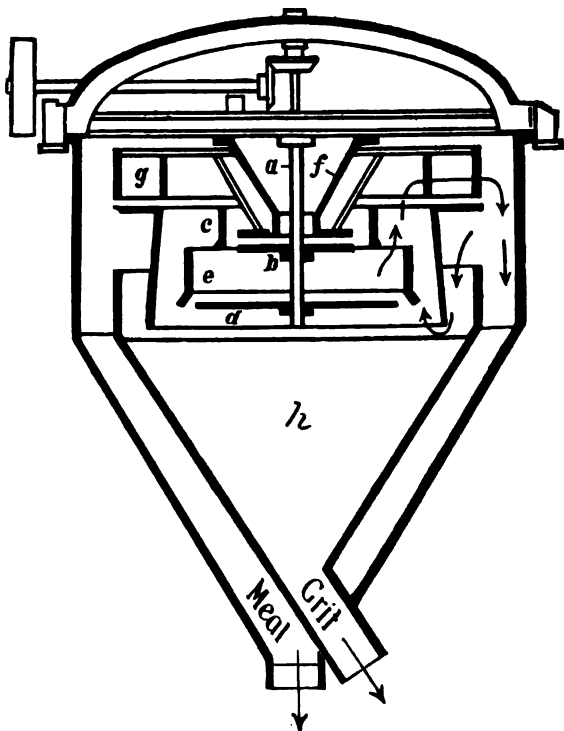

FIG. 3.

as shown by arrows, out of the apparatus to be transported to its destination, whilst the air, being sucked up by the exhaustor, re-enters the chamber enclosed by the two rings *e* and *c*. The unfinished material, or grit, drops from the lower disc *d* into the funnel *h*, and thence into the crushing-mill to be ground again.

This arrangement has been found very convenient and

economical, as all the slag which is ground fine enough is separated and carried away to its destination instead of being unnecessarily ground over again and again, as is done with

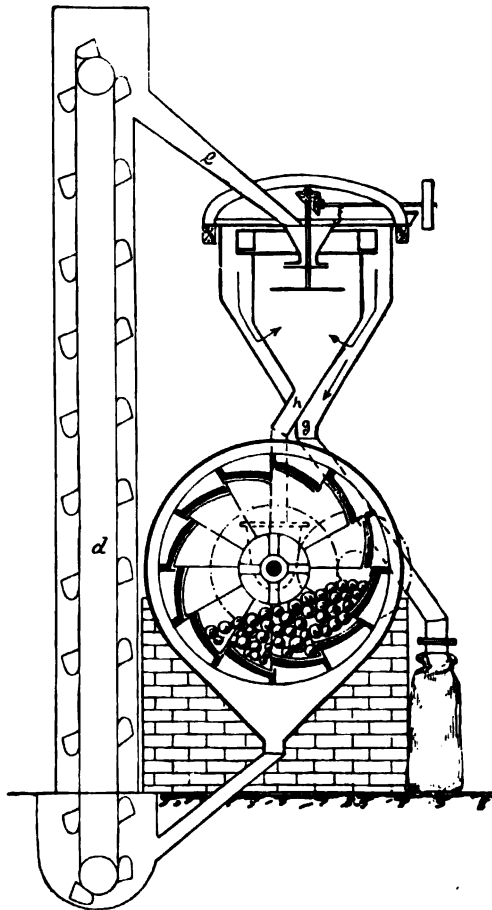

FIG. 4.

the so-called tube finishing-mill, the latter thus causing loss of time and of driving power.

Fig. 4 shows the arrangement of a complete set, consisting of a ball-mill, air-separator, and elevator. They are manufactured in different sizes for a production of from 1 to 9

tons of finished material per hour, leaving about 12 per cent. of residue on a sieve with 30,000 meshes per square inch.

CONCLUSIONS.

From what has been said it may be correctly concluded that blast-furnace works, especially those producing grey pig, have still a large field for improvement by utilising their slag in the way described, especially for making cement.

With reference to the question of getting a market for the cement, attention is to be drawn to the fact that it can be manufactured at considerably less expense than common Portland cement, and that therefore it can undersell the latter on the market.

It may also be mentioned that the consumption of cement is steadily increasing in a comparatively high proportion, because the employment of reinforced concrete instead of brick or stone, or of iron constructions, for buildings of all sorts, for bridges, viaducts, &c. &c., extends more and more. It may also be mentioned that the value of cement imported into countries beyond the sea represents the sum of about $1\frac{1}{2}$ million pounds a year.

That Portland cement made from blast-furnace slag has been employed for buildings, bridges, fortifications, railway embankments, &c., as well as for buildings in sea-water for the last fifteen years, without showing the slightest injury after so long a period, is proof enough that any prejudices against its use are thoroughly unfounded.

CORRESPONDENCE.

Mr. J. W. BROUGH, Assoc.M.Inst.C.E. (Brussels), wrote that the Colloseus process appeared to be merely the Passow process with the addition of a small quantity of solution of alkaline salts. The clinkers, whether granulated by the Passow or by the Colloseus process, had exactly the same appearance and behaviour. The two slags could not be distinguished from one another except by the traces of alkaline bases, originating from the decomposition of the alkaline salts, in the Colloseus clinker. If the slag were granulated by the Passow process,

and corresponding proportions of those salts or bases added to the clinker in the mill, the same result would be attained. The cement in both cases had no real commercial value, and it would be much more appropriate to add varying quantities of Portland cement clinker before grinding, because otherwise the slag cement would be wanting in binding and hardening properties. A second difficulty lay in the fact that the slags, if they possessed hydraulic qualities, would contain a large proportion of solidified glassy particles, and those glassy constituents were very difficult to grind. They were not only difficult to grind, but needed to be reduced to a far greater degree of fineness than ordinary Portland cement if the material were to possess properties of the same value as the latter. For that reason the combination of a ball-mill with a Mumford and Moodie air-separator was the most unfavourable imaginable. It was well known that the ground product of mill-stones, Griffin mills, and ball-mills combined with air-separators contained the very least quantity of fine flour, because the semi-fine particles were withdrawn from further grinding by the air-separator. The tube-mill, on the other hand, by further grinding those particles, which already passed through a sieve of 4900 meshes per square centimetre, produced the valuable and—owing to the increased surface—the most active constituent of properly ground cement.

The AUTHOR wrote in reply that it was correctly stated by Mr. J. W. Brough that the dry granulated slag produced by the Passow process (German patent No. 151,228 of 1902) could be rendered of commercial value by adding 10 to 50 per cent. of Portland cement clinker, according to the more or less basic character of the slag. By the Colloseus process (German patent No. 185,534) hardly any glassy slag was produced. The liquid basic slag was intimately mixed with the alkaline solutions and suddenly cooled, thus giving a product of good hydraulic properties. A mixture of one part of cement (made from blast-furnace slag by the Passow process) with three parts of sand, after twenty-eight days' hardening, gave a tensile strength of 12·3 kilogrammes per square centimetre; while a mixture of one part of cement (made from the same slag by the Colloseus process) with three parts of sand, after twenty-eight days' hardening, gave a tensile strength of 37·2 kilogrammes per square centimetre, showing that Mr. J. W. Brough's statements as to the value of the Colloseus cement were unfounded. His views, too, as to the Mumford and Moodie air-separator were not in accord with the results of Dr. Michaelis' tests (*Tonindustrie Zeitung*, 1906, No. 127). Moreover, taking into consideration the fact that the tube-mill was considerably more expensive, and that it required more space and motive power than a ball-mill with air-separator, the reason was apparent why several works manufacturing Portland cement from blast-furnace slag had recently adopted the ball-mill with air-separator in place of the tube-mill.

APPLICATION OF COLOUR PHOTOGRAPHY TO METALLOGRAPHY.

BY E. F. LAW, ASSOC.R.S.M. (LONDON).

IN the examination of alloys under the microscope a difficulty is frequently met with in selecting an etching agent capable of distinguishing the different constituents, and this is especially the case when it is required to show the constituents in a photograph. A well-known example of this occurs in the case of carbide and phosphide of iron occurring together in white iron, and although these constituents can be readily distinguished by an experienced eye, their appearance is very similar, and it is almost impossible to distinguish them in a photograph. Other examples are met with in bronzes, and particularly in the alloys known as special bronzes. In order to overcome the difficulty, and increase the actinic contrast between the constituents of an alloy, Professor Martens suggested heating the polished specimen until a film of oxide formed on the surface. Owing to the different rates at which the constituents oxidise, they assume different colours, and can be readily distinguished and photographed. The same results, but sometimes showing more brilliant colours, may be obtained by simply allowing the polished surface to tarnish by exposure to the atmosphere, and modifications of the process consist in heating the specimen in air containing iodine, bromine, or sulphuretted hydrogen. Ordinary photographs, however, of surfaces prepared in this way are necessarily unsatisfactory and often misleading, and it is important to be able to photograph the specimen in its natural colours. Hitherto the difficulty of the three-colour processes has been a great drawback, and those who have attempted it will agree that the difficulty of obtaining three negatives exactly similar and capable of being superposed to form a single image when working at magnifications of 1000 diameters is by no means imaginary.

The introduction of the autochrome plates by Messrs. Lumière of Lyons has removed the difficulty, and it is now possible to obtain a photograph in colour on a single plate and by a single exposure. The plates have been fully described elsewhere, and it is only necessary to remark that the process is a modification of the three-colour process. In front of the ordinary photographic film (or, to be exact, behind it, because the plates are exposed through the glass side) is placed a film formed of transparent starch grains of uniform size, and coloured respectively red, green, and blue, and mixed in the proper proportion to produce white. All the light, therefore, which reaches the photographic film has first to pass through this screen of coloured particles, and is resolved into its components, with the result that on development a black image is produced behind every starch grain which has transmitted light. The after treatment of the plate is exactly the reverse of the ordinary photographic process. Instead of fixing the plate by dissolving out the unaltered silver salts, the photographic image itself (*i.e.* the reduced silver) is dissolved out by acid permanganate solution, and the unaltered silver salts are blackened by exposure to light followed by development. The result, therefore, is not a negative but a positive on glass, showing all the colours of the original by transmitted light.

As soon as the plates were placed upon the market the writer obtained a supply, and was agreeably surprised at the truthfulness of the colour rendering and the suitability of the plates for photomicrographic work. A number of results were shown at the Royal Microscopical Society on November 20, and subsequently at the Quekett Club and the Society of Arts.

The disadvantage of the process (but probably only a temporary one) lies in the difficulty of obtaining prints on paper. On the other hand, the time spent in the dark-room is about three minutes, most of the operations being carried out in full daylight, and a photograph can be taken, developed, dried, and bound as a lantern slide in less than one hour.

DISCUSSION.

Mr. J. E. STEAD, F.R.S., Member of the Council, said he was sure they were all of one mind in being very thankful to Mr. Law for having given them such an interesting exhibition. The photographs were excellent, and the work Mr. Law had done was excellent likewise. There was one thing he thought they ought to remember; that the specimens had been tinted, in the way Mr. Law described, and many of them recognised the colours on the slides as those which they actually saw under the microscope. They were very much indebted to Mr. Law, and hoped he would continue his efforts in this direction. He proposed that the best thanks of the meeting be given to him.

The PRESIDENT said that he was quite sure the Institute would be glad to have an opportunity of thanking Mr. Law. *L'appétit vient en mangeant*, as Mr. Stead suggested, and similarly having seen so much, they wanted to see a great deal more. He was even greedier than that, because in his capacity as Chairman of the Metallurgy of Iron and Steel Committee for the Franco-British Exhibition he would like to have some of those slides to show on the stand at the Exhibition, and he hoped Mr. Law would be so grateful at that expression of their thanks that he would allow them to be shown. He had much pleasure in seconding the resolution.

The resolution was carried with acclamation, and the proceedings terminated.

CORRESPONDENCE.

Mr. J. MIDDLETON (Sheffield) wrote that the application of colour photography to metallography was interesting, and for purposes of illustration it would doubtless prove useful; but, apart from that and the purely artistic considerations, he failed to recognise its special claim over that of monochromatic photography as an instrument of research. It should be remembered that with few exceptions, such as the sulphide of manganese, the colorations produced by heat-tinting were intrinsic qualities; the tinting was comparative and progressive, and thus a certain constituent might successively exhibit every tint in the chromatic scale. For that reason the differential tinting effects of the metallic section might generally be satisfactorily represented in monochrome. The well-known defect of the ordinary photographic film rendered it of special value in metallography, in that it exaggerated slight differences of tint and thus was capable of throwing into relief faint colour effects which the eye would fail to differentiate.

In other words, the colour photograph represented more or less normally the visual appearance of the tinted section, whilst the ordinary photographic film exercised a very useful selective action.

Mr. LAW wrote in reply that Mr. Middleton's views of the utility of photography in scientific research were so totally at variance with those generally accepted that it was difficult to find a common ground for argument. As far as he (Mr. Law) was aware, however, neither ordinary nor colour photography had ever been put forward as "an instrument of research" in metallography. Most persons, he thought, were agreed that the value of photography lay mainly in the fact that it enabled a more or less permanent record of things seen to be obtained, and the value of such a record was proportional to the accuracy and truthfulness of the rendering. But not so Mr. Middleton. Those considerations he regarded as "purely artistic," and only useful for "purposes of illustration." His argument that because colours might be progressive therefore they were satisfactorily rendered in black and white was too illogical to require comment. That the need for something more satisfactory than a black and white photograph had long been felt by others besides the author would be evident to Mr. Middleton if he would consult No. II., 1898, of the *Journal of the Iron and Steel Institute*, in which he would find a paper by Professor Arnold illustrated with coloured drawings. Mr. Middleton's ideas with regard to photography were equally inaccurate. For example, it was hardly necessary to point out to any one possessing the most elementary knowledge of photography that his statement that the ordinary photographic film exaggerated slight differences of tint "which the eye would fail to differentiate" was totally incorrect. Whereas in some cases the ordinary plate exaggerated the contrast, in an equal number of cases it diminished contrast, and in both cases the fault was equally serious and the photograph was of little value as a scientific record. So widely was that fact recognised that for some years past the efforts of scientific photographers had been unceasingly devoted to the problem of overcoming, by means of specially treated plates and light-filters, that defect of the ordinary plate.

The following papers were taken as read :--

A NEW TYPE OF ELECTRIC FURNACE FOR THE SMELTING OF IRON.

BY PROFESSOR B. IGEWSKY (KIEFF, RUSSIA).

It may easily be shown that a supply of electrical energy equal to 500 kilowatts is sufficient for the smelting of one ton of steel. Electrical engineering of the present day has already constructed dynamos capable of developing ten times as much energy, and is indeed able to supply such energy at a very cheap rate, particularly when a gas-engine is used to drive the dynamos.

With such conditions the electric furnace should be capable of producing steel more cheaply than by the open-hearth process; the crucible steel process, which is becoming obsolete, may be excluded as a method for the production of steel on a commercial scale.

Many works already employ electric furnaces, such as Stassano, Kjellin, and Héroult electric furnaces. These furnaces work very successfully, but they all employ low tension electric current (not exceeding 100 volts), or they themselves act as transformers. The author will describe a method of working with high-pressure electric current, of which he has had seven years' experience. The furnace is one of a type employing what may be called second-class conductors, such as magnesia, lime, silicates or their colloids, such as Al_2O_3 , 2SiO_2 , which, on being greatly heated, become conductors. It is absolutely necessary that the current should pass in the thinnest possible layer over the lower surface of the bricks as shown in Fig. 1. The resistance to the current should be very great in such a furnace. The pressure should be 1000 volts for each metre space between the electrodes. By bringing the electrodes nearer together, or placing them further apart, or by providing the furnace with a number of electrodes, and only charging those which are immediately needed, it is possible to obtain a furnace which will work with

all strengths of current in ordinary use. Such a furnace should work as steadily as an incandescent lamp, and should develop the highest temperature that the bricks can support. The problem is, however, not entirely solved. Difficulties are

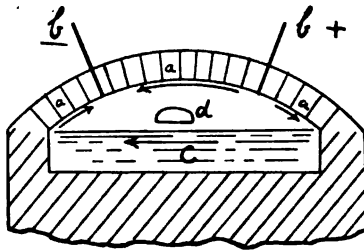

FIG. 1.—*a*, Firebricks; *b*, *b*, electrodes; *c*, smelted metal; *d*, working opening.

presented owing to a phenomenon analogous to that which the author has found to occur in the blast-furnace, and to which he gave the name of differentiation.* The electric

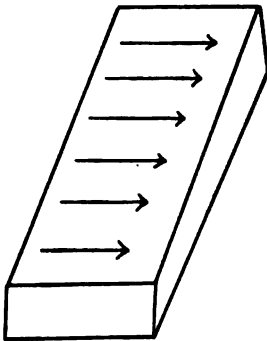

FIG. 2.

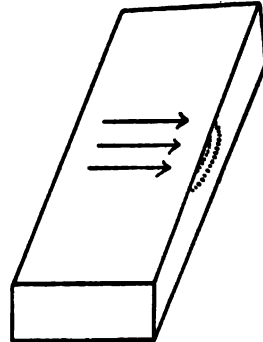

FIG. 3.

current only flows over the surface of the brick during the earlier stages (Fig. 2). In a very short space of time it concentrates itself along the lines of least resistance. Little by little the path selected becomes the only zone affected and

* *Revue de Métallurgie*, vol. ii. p. 842.

the remaining surface remains quite cool (Fig. 4). Differentiation can be obviated by dividing each electrode into a number of smaller electrodes furnished with regulators. Such a system could be employed for the firing, *e.g.*, of porcelain.

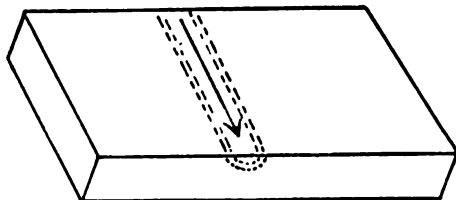

FIG. 4.

The application of the principle to the manufacture of steel and to the fusion of other smelted materials is more easily solved by the furnace being made to revolve, and supplied

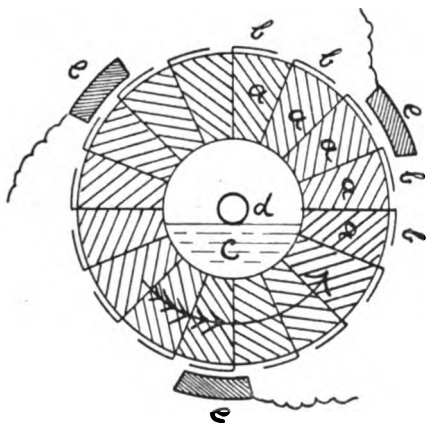

FIG. 5.—*a*, Firebricks; *b*, *b*, electrodes and parts of collector; *c*, smelted metal; *d*, working opening; *e*, *e*, brushes which remain immobile during the rotation of the furnace.

with a sufficient number of electrodes, so that the current does not suffer interruption. In such an arrangement the bricks will at one time form the vault and at another the bottom of the furnace. By this means the variations in temperature can be avoided, and each brick passing beneath

the metal will have the same conductivity over the whole of its surface as any other brick. In addition to this the bricks

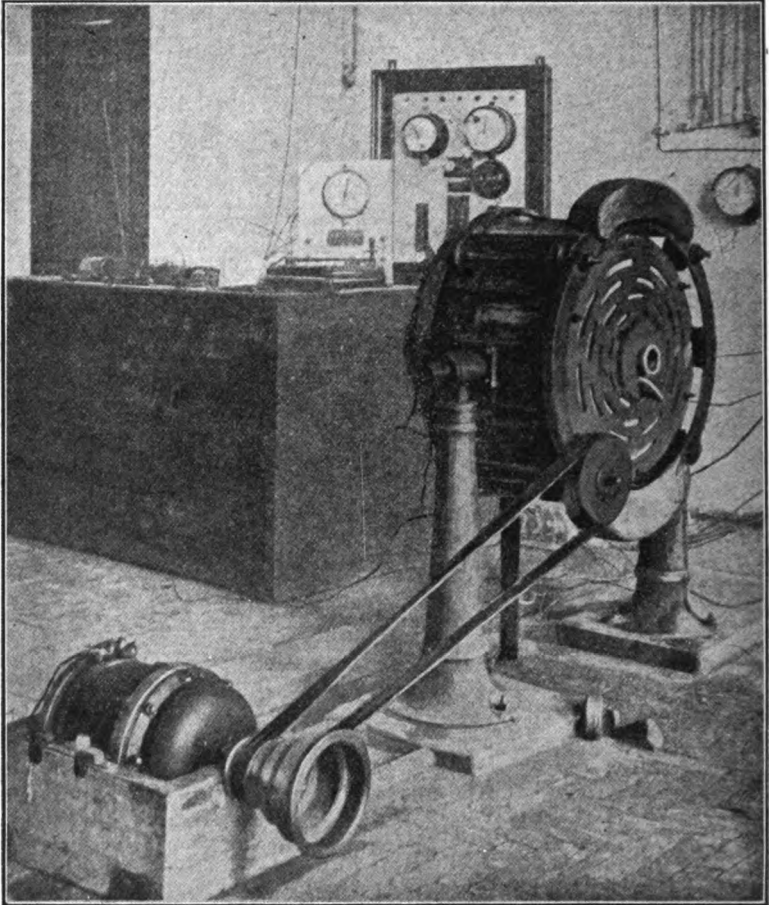

FIG. 6.

will be automatically moistened with slag, so that their surfaces become better conductors than their interiors.

If the principle of a revolving furnace be adopted, it is necessary that it should be furnished with a commutator, otherwise the current will short circuit through the metal.

Fig. 5 shows a plan for a rotating furnace using three-phase current, while Fig. 6 gives a front view of a furnace installed in the Emperor Alexander II. Polytechnic Institute at Kieff.*

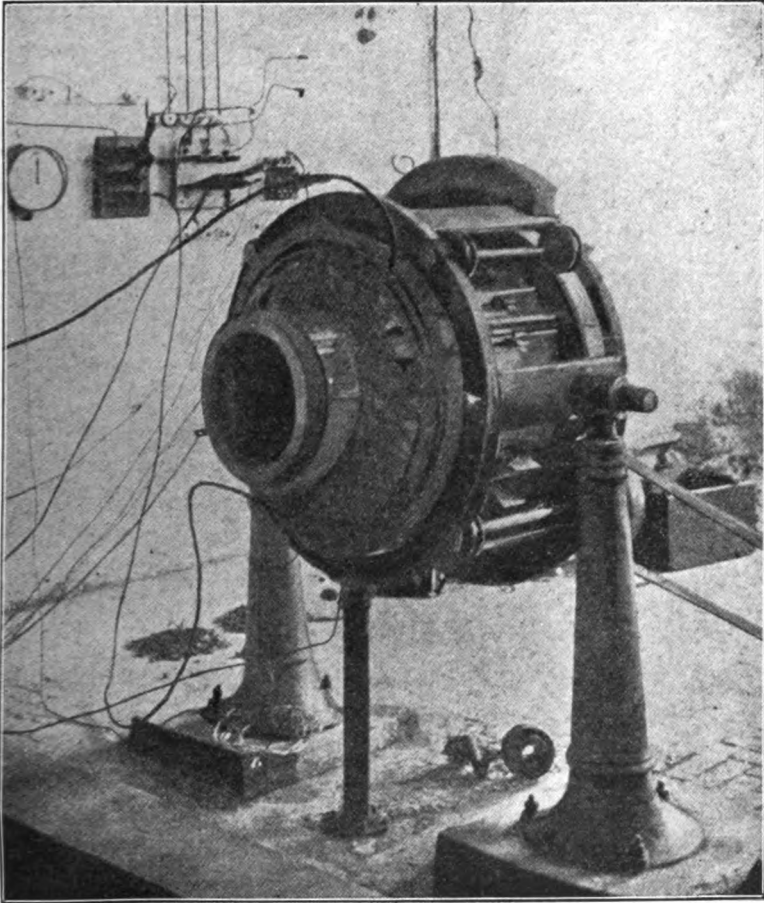

FIG. 7.

The opening through which the charge is worked, the outlet, and the motor which rotates the furnace about twenty times per minute are shown in the figure. Fig. 7 is a view of the

* The author wishes to record his thanks to the designer of the furnace, Mr. A. E. Tzaref.

back of the furnace from the side of the commutator, which was made larger than usual in order to give access to the

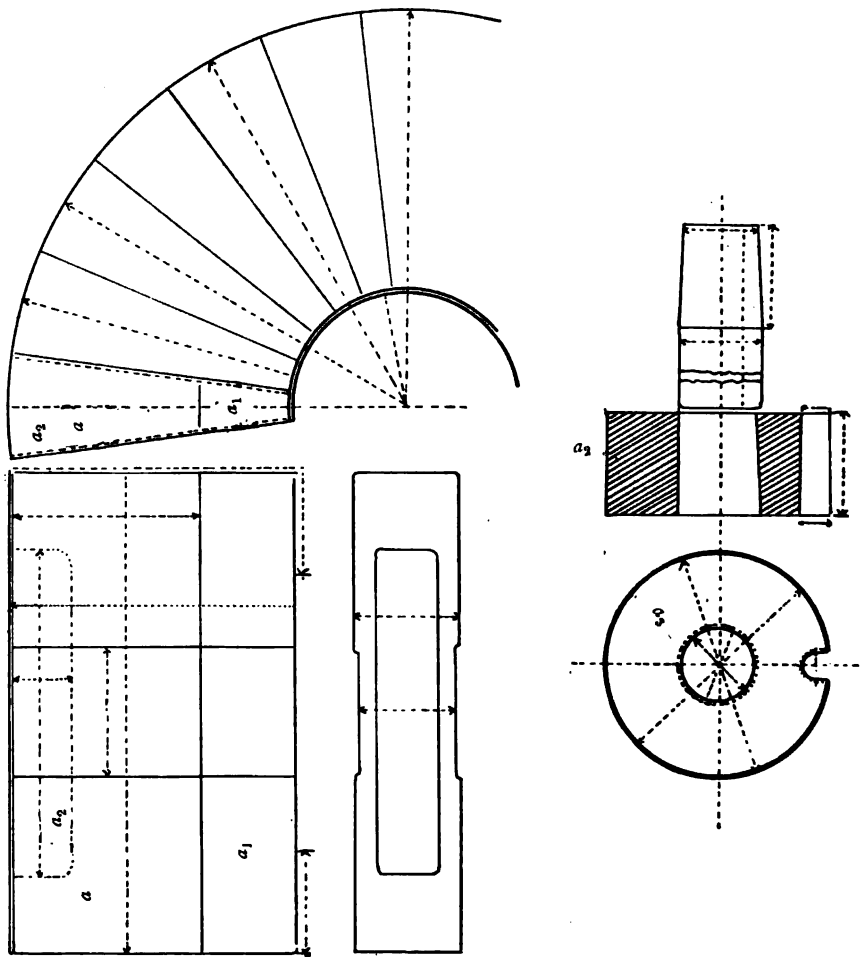

FIG. 8.

furnace from that side. This was for experimental purposes, but is not essential.

It is possible to construct a free commutator connected with

the furnace by a cable. In the illustration the rollers can be seen as well as the pivot which allows of the furnace being tilted in order to empty it completely. Fig. 8 shows the form and dimensions of the bricks, a being the outside bricks, and b the whole arrangement devised for the purpose of cooling the furnace, or as an air-chamber for reducing heat losses.

In practice it was not found necessary to adopt this plan. a_1 shows the inside bricks which have to be changed more frequently, and a_2 the circular bricks for the front and back walls of the furnace with the working opening and the opening for the outflow of the metal and slag. CI shows the space for the electrodes, while Fig. 9 gives the front and side elevation of the furnace. All the plates are of cast iron; aa , a_2a_2 are bricks, bb are electrodes placed between the bricks, and $c'c'$ parts of the commutator, ee are the electric brush holders. The inside diameter of the furnace is 175 millimetres, and the depth 215 millimetres. The cubic capacity is 5.17 litres. The space that can be occupied by metal is, however, only about 2 litres, and at the commencement little more than 10 kilogrammes can be charged. In the course of time the interior bricks wear, and the capacity of the furnace becomes greater.

The author prefers a three-phase electric current, but usually employs a continuous current of 250 volts and 50–60 amperes, *i.e.* 12–15 kilowatts. When cold the furnace is a non-conductor.

The process of smelting is conducted in the following sequence of operations: The flame of a gas or Bunsen burner is made to impinge through the working opening, and when the furnace has been slightly warmed a little damp potassium hydrate is charged and the furnace is rotated. It will now be found that the furnace acts as a conductor, and the electric current begins to warm it. After a short time sodium hydrate is added, and when the interior of the furnace is red hot sodium carbonate is charged. The corrosive alkalies which evaporate within the furnace do not cause as much harm as might be expected. Rapid heating is, however, a danger to the bricks, which begin to crack. The best plan is to warm the furnace with gas during the night preceding the experi-

1908.—i.

A NEW TYPE OF ELECTRIC FURNACE

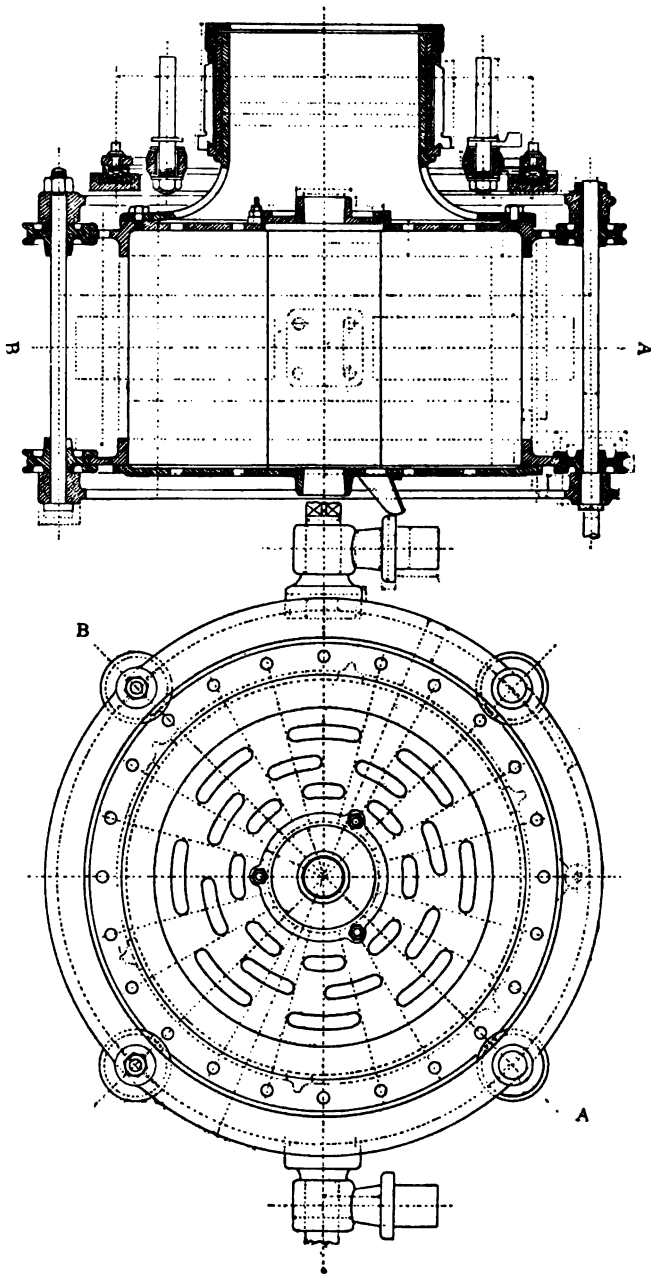

FIG. 9.

ment. When the temperature of the furnace reaches a light red heat cast iron may be put in, and then scrap, or the order can be reversed. In the first case the author is in the habit of adding the new material gradually as the charge melts. In the latter case, when the iron becomes sufficiently hot, the smelting takes place at once on the addition of cast iron.

If a quantity of cold metal be suddenly introduced at one time, it is easy to reduce the temperature to such an extent that short circuiting occurs, as shown in Fig. 10; *a*, *b*, *d*, and *e* bear the same significance in this figure as they do in the pre-

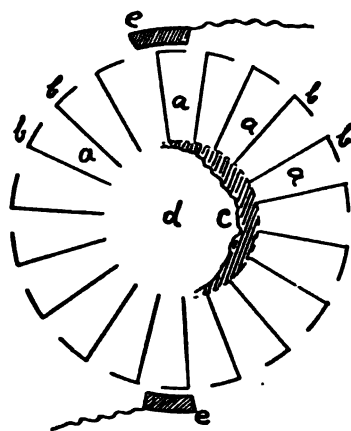

FIG. 10.—*a*, *b*, *d*, and *e* represent the same as in the preceding illustrations; *c*, the cooled metal which causes the short circuit of the conducting brushes.

ceding illustrations, *c* being the cooled metal which causes the short circuiting of the conducting brushes. The same thing occurs if the furnace becomes cool with the metal inside; small furnaces cool down in an exceedingly short time. In a large furnace where there is a considerable margin of heat, such an accident is hardly likely to occur. Indeed, in order to bring them into working condition, it would suffice to charge some hot slag from some other furnace and to avoid having recourse to soda, which could not be other than injurious to the bricks. The outer bricks of the author's furnace are of fireclay, and the inner of fireclay or dinas. The fireclay bricks are fairly

good conductors, but the dinas bricks are exceedingly poor conductors. The author has, however, used both for years with successful results. With fireclay bricks care should be taken that less slag should be used. With dinas bricks it is his custom purposely to add fluorspar, cryolite, magnesia, and similar substances, in order to increase conductivity. Magnesite bricks appear to be ill-adapted to the purpose, because they conduct too easily, while the current of 250 volts would, with the existing dimensions of the furnace, be too great for these bricks. Experiments with dolomite and other bricks have not yet been carried out by the author.

The electrodes in the furnaces illustrated are of iron. At

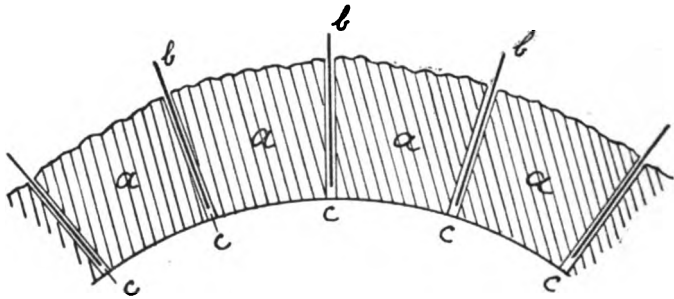

FIG. 11.—*a*, Bricks; *b*, *b*, the ends of iron electrodes; *c*, *c*, slag and drops of smelted steel in crevices between the bricks.

first sight it seems astonishing that they could be made to work in a furnace in which steel is being smelted. As a matter of fact the electrodes melt and become slightly absorbed in the interstices of the bricks. But as the heat is developed on the surfaces of the bricks lining the inner side of the furnace, the crevices around the electrodes remain at a moderate temperature, because they retain the slag and even drops of metal which act as conductors (Fig. 11). The author at first employed electrodes of 3 to 4 millimetres in thickness, so as to drive them into the furnace from time to time by means of a hammer, but as that appears to be unnecessary he now employs thin sheet iron electrodes. There are in the furnace twenty-four electrodes placed at intervals of 23 millimetres from each other. As in the furnace filled with liquid steel

only the fourteen upper bricks constitute the working surface, a difference in potential of $25\frac{1}{2}$, or nearly 35 volts, is obtained between adjoining electrodes. As a result sparks are emitted on the collector on replacing each electrode, and frequently the spark is transformed into a voltaic arc. As shown in Fig. 12, the path of the voltaic arc to the collector is shorter than that through the conducting brick. On the distance between these electrodes being reduced to 12 millimetres, the difference of potential falls to $17\frac{1}{2}$ volts, and the formation of the arc becomes impossible. The author has, however, adopted an alternative. Each flat piece of the collector is divided into three parts, connected to each other with rheostat wires. By these means each electrode becomes gradually shut off when-

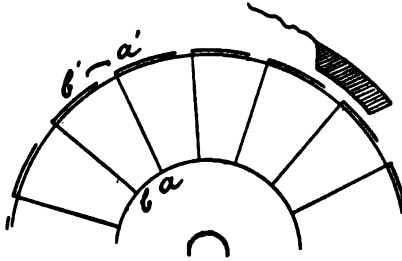

FIG. 12.—*a', b'*, Voltaic arc on the collector.

ever the difference of potential reaches the vicinity of 12 volts, and the formation of a voltaic arc is impossible. Besides that, he has fixed an additional description of brush on the electrodes, joined to the rheostats. This brush similarly serves to lessen sparking. The method employed to obviate sparking is the only complicated part of the furnace, the remaining principles being quite of an elementary nature. The manipulation of the furnace is likewise exceedingly simple, although with its present very small dimensions it requires constant attention. As a rule the author smelts a small quantity of cast iron and afterwards adds scrap. The softest steel produced possesses an ultimate strength of 56·8 kilogrammes per square millimetre, with an elongation of 20 per cent.

On smelting iron turnings with charcoal (1 per cent.) steel was produced with an ultimate strength of 85·6 kilogrammes

per square millimetre, and an elongation of 3 per cent. Experiments for the production of steel from cast iron by the ore process were also successful, and the fireclay bricks suffered less than might have been anticipated. The advantages of a furnace of the construction indicated above are as follows:—

1. High voltage and low expenditure of current.
2. The possibility of using any form of current ordinarily employed.
3. Compactness and high efficiency.
4. Great homogeneity of the metal produced.
5. The minimum amount of surface contact with air or with the walls of the furnace.
6. Slag at a high temperature, and therefore favourable to the reactions needed for the refining of the metal.
7. A minimum superheating of the furnace.
8. The avoidance of carbon electrodes.
9. The possibility of using the furnace for the production at a high temperature of any material in a fluid state.

THE PHYSICAL QUALITIES OF STEEL IN RELATION TO ITS MECHANICAL TREATMENT.

BY JAMES E. YORK (NEW YORK).

It is my purpose in the present paper to attempt to review the existing methods for the mechanical treatment of steel, and to suggest some changes which I believe will result in the production of more reliable steel rails and other similar sections than those now produced by ordinary methods.

In the United States during the year 1907 there has been continual controversy between the railroad officials and the steel manufacturers, the former asserting that the rail metal was not as good as formerly, and the latter that the cause for the frequent rail fracture is poor track construction and the much greater axle loads used. There cannot, however, be such a divergence of opinion without bringing some light into the subject and making for an improved quality of rail in the future.

It is conceded on all sides that the chemical composition is now under much better control than formerly, so that, even with the comparatively high percentage of phosphorus in use in America, it is certain that reliable steel can be produced if the mechanical treatment is on correct lines. In this connection I may quote Mr. Robert W. Hunt, who has been more closely connected with rail-making in its various departments than any other authority with whom I am acquainted. In 1904 Mr. Hunt read a paper on rail steel, in which he made the following statement: "I have repeatedly said that the mechanical treatment of the metal forming the steel rail during its manufacture is comparatively of much greater importance than its chemical composition, and years of observation confirm and emphasise this fact."

During the last forty years almost all the improvements in the mechanical treatment of steel, especially of rails, have

been in the direction of increased output. Whereas forty years ago 150 tons per shift of twelve hours was considered good work for a mill, now 1200 tons are expected in the same time. It is stated by some eminent metallurgists that this increased output is the chief cause of poor rails, the steel being "squirted" through the rolls, as they express it, so that a rail of 100 lbs. weight per yard is now produced in fifteen to twenty passes, whereas formerly thirty or more were required to obtain a 60 lb. to 65 lb. rail.

Probably Mr. A. L. Holley, of distinguished memory, Mr. R. W. Hunt, Mr. John Fritz, and the late Captain Jones have done more to add to this increase in modern rail produce than any one else. Mr. Holley read before this Institute in 1874 a paper, under the title of "American Rolling-Mills," describing a rail-mill of about that date.

The blooming-mill was 3-high, with rolls 30 inches in diameter, and it was run at from forty-five to fifty revolutions per minute. On this mill a 14-inch square ingot was reduced to a 7-inch or $6\frac{1}{2}$ -inch billet in sixteen to eighteen passes in three and a half to four minutes, the ingots weighing about a ton, and they were intended to produce two 30-foot rails of 65 lbs. to the yard. The top third of the ingot is sheared off so as to produce only sound rails, thus giving about 150 tons finished rails per day of twelve hours. The diameter of the rolls of the finishing-mills was from 21 inches to 24 inches, and the number of revolutions seventy to eighty per minute. In these mills the billets were reduced into rails in from thirteen to fifteen passes, making the total number of passes about thirty.

In England the practice was almost identical, excepting that in some cases the ingot was hammered to the proper-sized billet for the finishing-mill. Although this was more costly, it undoubtedly produced a billet with better physical qualities, provided that the heating had been carefully attended to. My own personal experience at that time entirely confirms these statements.

The rails referred to by Mr. Robert Job, metallurgist, in a paper read by him before the Railroad Club, as lasting in the track of the Philadelphia and Reading Railroad for thirty-four

years, were made at Messrs. John Brown & Co.'s works in Sheffield in 1864. These rails were most likely rolled from hammered billets.

It would appear that all steelmakers, when striving for export trade, will produce, if possible, an article superior in all essential qualities to those for domestic use, and this is natural, as he wants to extend his business. This seems to be confirmed by the fact that in English rail-making experience there is hardly any case of steel rails lasting over twenty-five years, whereas, according to Sir Lowthian Bell, iron rails in many cases last this time.

HEATING INGOTS.

The chemical composition of steel ingots may be all that can be desired, but if they are not properly heated the quality of the steel is seriously affected, and no subsequent treatment short of cooling and re-heating to the proper temperature can eliminate the defects. Burnt steel is not only more or less damaged for use, but makes very poor scrap.

In order to produce reliable steel it is absolutely essential that the heating should be carried out and controlled in the most careful manner. Although the importance of proper heating is generally understood, there is yet no branch of the steel industry which is left so much to the "rule-of-thumb" method as the heating of rail steel. The men who do this work have very little comprehension of the relation between the colour of the ingot and its temperature, and, as is well known, at the same temperature steel looks much hotter at night than in the day. The successful heater is one who can guess the hottest temperature at which the steel will roll without cracking, as naturally the hotter the metal the softer it is, and hence the reduction is easier and more rapid. However, this method has two serious defects, as the first, overheating, destroys the best structure of the steel, and, in addition, the finishing temperature is so high that no proper fining of the grain is possible.

Recent investigations have conclusively shown the deteriorating effects of overheating, and that these can be only

restored by cooling to normal temperature. There is no doubt that the care employed in heating crucible steel accounts for the excellent physical qualities usually found in steel of this grade. In the earliest stages of Bessemer steel manufacture the heating of rail ingots was governed largely by the practice in use for tool steel until the introduction of low-carbon steel to take the place of soft iron, and to which a high temperature can be given with more impunity than to higher carbon steels.

The usual method of heating steel rails was as follows: The ingots were laid in a horizontal position during heating, which allowed of the frequent examination and turning of the ingots so that they could get uniformly heated without much trouble. At the present time the pit is charged with ingots in a vertical position, which undoubtedly is more economical, but the steel is usually still fluid in the interior of the ingots when they are introduced. In this connection the instructions for heat treatment in rail specifications are rather vague, "that ingots are not to be drawn until the steel in the interior becomes solid, and are not to be heated enough to make the cinder run." There is nothing in the instructions to guard against overheating the steel, nor do they indicate what degree of heat is intended.

As a conclusion, I would draw attention to the following principles:—

1. That the finishing temperature should be as low as is possible to get best results, and that the initial must not be above another limit, about 950° C.

2. That if under these conditions the ingot cannot be rolled to 4-rail lengths in one operation, the initial size should be reduced.

SOLIDITY OF STEEL INGOTS.

The iron and steel business owes more to the rolling-mill for its development than to any other element connected with it. I am inclined to believe that the inventor of grooved rolls, Henry Cort, never saw any other sections rolled than rounds, flats, squares, and plates, and for the production of these shapes no better machine exists than the ordinary rolling-mill. However, the evolution of railroads and other

large users of steel having demanded the production of more complicated sections, the rolling of which is attended by some difficulty when steel of the best physical quality is demanded, some of these difficulties will now be considered.

First, the lack of penetrative action in rolling. It is well known that in the reduction of a large or even medium-sized ingot there is very little fining of the grain until the thickness has been very much reduced, and the temperature is near the bottom limit. This is particularly noticeable in the rolling of ingots into billets and slabs.

Steel ingots, even when produced with the greatest care, suffer to a great extent from three defects—pipes, segregation, and blowholes. The last is the cause of No. 2 rails generally. In consequence of these defects and the inherent weakness of the steel at this juncture, the ingot should be reduced slowly at first, with the large end presented to roll. This method will facilitate the raising of the segregate, otherwise cracks develop, which are liable to remain unclosed, especially if there is any oxidation.

In consequence of the small penetrative action, there is no closing of the pipe, which is merely stretched proportionately with the billet. As a result there is an inherent and hidden weakness in a more or less large proportion of the billet, which if subsequently used for rails can only yield a low quality product. As you will know, such defects in rails are one of the principal causes of rail fracture, with all the danger attendant on this. Professor Howe and many other leading metallurgists and chemists have given much thought as to how pipes and segregated matter can best be eliminated from ingots. The general consensus of opinion amongst experts is that it cannot be done by chemical means, but must be done by mechanical if at all. At present the method is to chop off from the end of the billet a certain proportion, which is supposed to be sufficient to leave the remainder homogeneous, but this way is unreliable.

As I have stated above, ordinary mills stretch the metal by rolling, and therefore lengthen both the pipe and ingot simultaneously. Under these conditions it is impossible to close the pipe in the blooming-mill. It has been suggested that by

rolling the ingot more slowly the pipe might be closed and possibly welded. This, however, is a mistaken idea, as the only result of slow rolling is that you can increase the work on the section up to the frictional limit, increasing the reduction per pass, but it is impossible to do more.

Several mechanical methods for compressing ingots have been tried, and are more or less successful as machines. However, they all possess the drawback of being slow in operation, and hence have not been seriously applied to rail manufacture, as they would greatly interfere with the output and increase the cost. It is absolutely essential that the ingot should be comparatively free from pipes and blowholes before the operation of rolling commences in the blooming-mill, otherwise there cannot be produced a billet of proper structure from the top of the ingot, and consequently the rail with the necessary physical qualities cannot be produced unless the ingot is solidified before it is bloomed, or the necessary top portion sheared off after.

SOLIDIFYING INGOTS BY TRANSVERSE ROLLING.

The necessity for some cheap, quick, and efficient method for solidifying ingots induced me to apply my method of transverse rolling to this problem. The mill, with slight changes, in which this is carried out was described in a paper read at the joint meeting of the American Institute of Mining Engineers and the Iron and Steel Institute in London in 1906, to which reference may be made for details and other applications. Fig. 1 shows an end elevation of the mill with six ingots in place for treatment. The ingots are arranged alternately reversed so as to save room, and the number of ingots may be increased or diminished as is found desirable or the dimensions of the mill allow. The ingots lie on a comparatively level horizontal table, and are first operated on by the plain roll, which closes any surface blowholes. The ribbed roll is so constructed that the distance between the ribs corresponds to the distance between the centres of ingots and the corresponding rib on the base; the ribs are preferably made removable so

that they can be provided of the right length and contour to suit any particular series of ingots, but in all cases the rib must be longer than the pipe to be eliminated. The operation of rolling involves the use of comparatively little power, since the metal is merely shifted inwards along the line of the pipe. It will usually be sufficient, owing to the taper of the ingot, to have ribs of the same depth throughout, and in

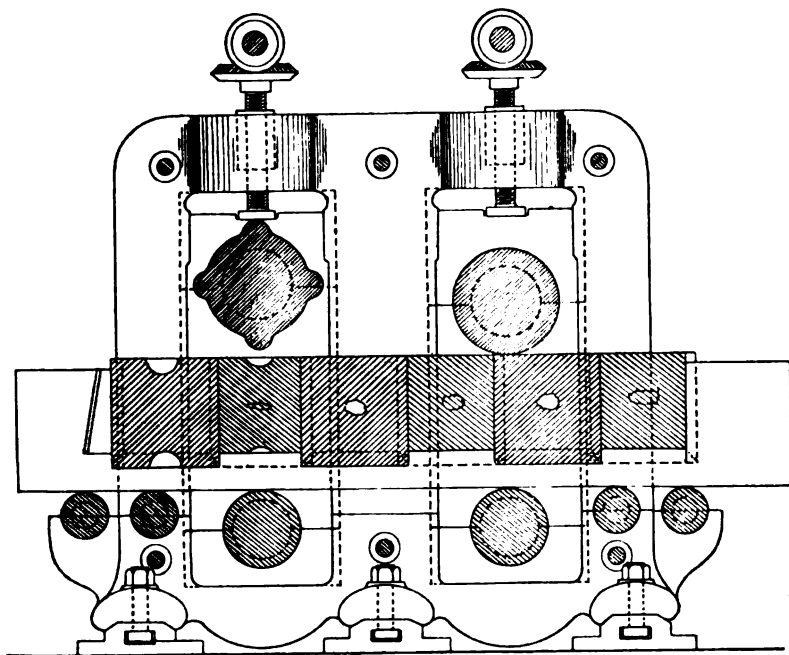

FIG. 1.

consequence the rib will make contact first at the bottom of the pipe, and will gradually squeeze out any segregated material. However, if desired, the ridge may be tapered, or the plain roll may have a collar at any particular point for the purpose.

With this method the ingot will be left with two grooves of semi-circular section which, however, will not interfere with the subsequent rolling. To avoid this, if desired, the ingot

may be cast with ridges, which when forced in will leave the surface comparatively plain.

The mechanism is so arranged that the ingots are brought automatically into the correct position, and the rolls are vertically adjustable so that the bed may receive its full stroke immediately.

RAIL FINISHING-MILL.

As I have mentioned above, the work done by the rolls working with their faces parallel in the manufacture of blooms,

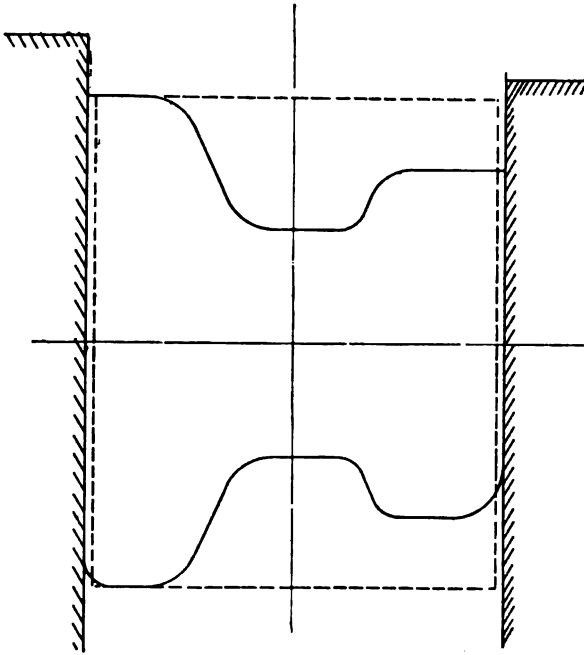

FIG. 2.

plates, and flats is satisfactory. It is only when rails and other flange sections have to be produced that the more elaborate rolls required do not give the same satisfactory results. Fig. 2 shows the general form of the first shaping pass from a billet to a rail, varying with the dimensions required in the finished

rail. It is clear that the metal in the web and head is the only part of the billet which receives any material reduction, and as the flanges and head are gradually formed, less and less true rolling action is performed upon them. The action which can take place in these parts, where the roll surface is at right angles to the rail, can only be largely of the nature of wedging or drawing. The result of this must be a condition of unequal stress in the flanges. Another serious defect in the use of these rolls for flange sections is the great difference of surface speed at different parts of the section, the diameter of the roll forming the wedge being frequently 5 inches larger than a portion in contact with the extremity of the flange, and sometimes more. As a consequence the web is delivered from the roll much faster than the flange, where the metal must either slip or stretch to compensate for this (see Fig. 3). This is the principal reason why, when the flange breaks, the fracture is almost always crescent-shaped, as described by J. P. Snow in the *Iron Age*, January 23, 1908, and by many others. The head of the rail is formed in a similar manner but of less degree, and does not suffer to the same extent, as, having a large mass and hence cooling more slowly, it can stretch and accommodate itself more easily. However, the higher temperature at which it is finished makes the head always softer than the flange or web, the reverse of what is necessary in a serviceable rail. The T or Vignoles rail, which is to be commended on account of its adaptability to quicker and cheaper construction in railroad tracks, will always suffer to some extent from this defect with the usual method of rolling.

In the case of the bull or double-headed rail used generally in England, the quality will in general be better in consequence of the similarity in width of the head and base, which permit of them being finished at approximately the same surface speed and about the same temperature. These rails require more uniform sleepers, heavy chairs, and apparently cost per mile for maintenance. As I believe the axle loads in England do not exceed 60 per cent. of those in use on the first-class lines in the United States, the proportion of rail fractures is comparatively small. However, out of the total number of 284 rail fractures in the

United Kingdom in 1906, 66 were T rails, which do not exceed 5 per cent. of the total rails in use. This confirms my statement as to the defects in these rails.

The T rails referred to by Mr. Job as having given such excellent results in service (thirty-five years), were narrow flange rails and were much more expensive, costing quite three or four times the present price. Both these facts must be taken into account in considering their quality.

The designing of rolls for producing steel sections of all sorts, and especially T sections such as rails, requires very considerable experience, and has an exceedingly important bearing on the result obtained. Too generally the principles employed in the reduction of steel have been influenced by the possibilities in iron rolling, although the conditions were largely different. The high initial temperature permissible in iron permitted greater reduction per pass up to the frictional limit, and also a greater amount of guessing as to the possible reduction. Usually the first passes were intensified by scarring or roughening the roll face without damage to the resulting finished section; but this procedure cannot be used successfully with steel sections.

At various times during many years I have noticed that there was no systematic reduction in the passes as designed, and that sometimes the roller was in the habit of even skipping a pass. It therefore seemed to me that it was desirable to work out a method for the systematic reduction of metal, and I instituted experiments to discover the possible reduction in various-sized rolls. From the data obtained I was able to work out a method of fractional reduction which enabled me to know whether it was possible to produce a steel section in a given number of passes. In this way it was possible to avoid with certainty any chance of roll fracture or of choking.

By applying this system I find that the remarkably good quality exhibited in rails made forty years ago was obtained by rolling at a low initial temperature. Taking a 14-inch ingot, the size used in this case, and a factor of 0.9, the lowest factor ever used in my practice for steel of that hardness, I found that it required thirty-two passes to obtain a 65-lb. rail. It is not to be supposed for a moment that the most

skilful steel manufacturers in the world at that time were working these at a lower capacity for amusement, and if similar good qualities are required to-day it is necessary to work under relative heating conditions. I am informed that at the present time a 22-inch square ingot weighing 2 tons can be rolled into four-rail lengths in fifteen to twenty passes, and it is clear that a considerably higher initial temperature must

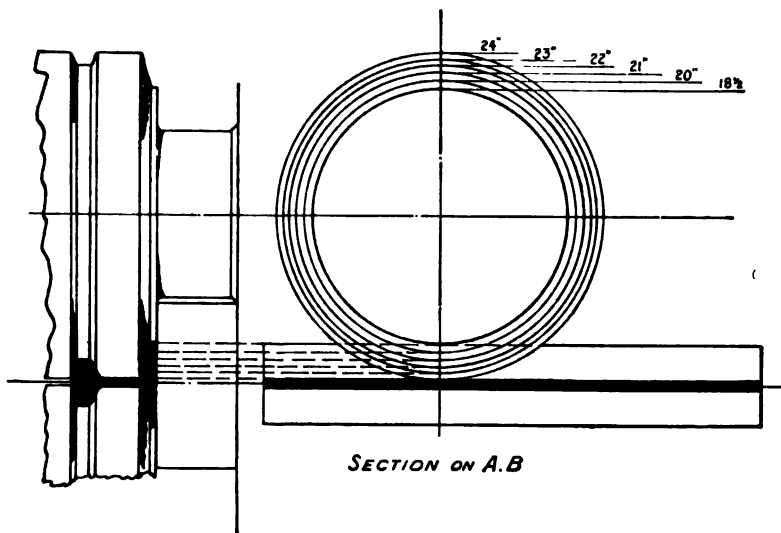

FIG. 3.

be employed, with the result that there is less effective work on the material, and that the resulting quality is inferior.

Steel rolling, with the conditions of greater hardness and lower temperature, requires a harder and stronger roll than was the case with iron. However, the only class of roll which keeps its shape under the condition of work now required is the hard chilled roll, which cannot be adapted for deeply-grooved rolls, as now used in rolling rails at the finishing passes.

In my paper above referred to I also described my universal mill, which can give the finishing passes at the lowest possible temperature and with the hardest surface to the rolls. Owing
1908.—i. M

to the special construction of this mill, beams of small depth with a 12-inch flange can be delivered perfectly straight from the roll. Also, owing to the presence of the side roll, rails can be produced without the internal strains mentioned above, and, in consequence of the possibility of doing more work there, with a better wearing quality metal in the head.

The high speed given to rolls in modern rail-mills is repeatedly referred to as one of the chief causes of inferior rails. This is in a large degree a mistaken idea. If the metal being rolled is comparatively solid and has not been overheated and the rolling action is on proper lines, there will be no damage to quality other than incidental to the shape of pass (Fig. 3); as before described, the speed of delivery of a modern rail-mill is about 650 feet per minute. The York universal mill is now rolling beams at a speed of about 1600 feet per minute without deteriorating the physical qualities of the finished product. This is made possible by side-rolling action, which dispenses with the different speed delivery referred to in the ordinary mill, also the wedging and drawing action now inherent to the ordinary process when rolling rails and other flange sections.

CASE-HARDENING.

IN addition to the discussion on the papers by Mr. G. Shaw Scott, Mr. Percy Longmuir, and Mr. L. Demozay, published in the *Journal of the Iron and Steel Institute*, 1907, No. III., the following communication, dealing more especially with the subject of Mr. Shaw Scott's paper, has been received from Mr. S. M. Schindler (Chester):—The importance of case-hardened machinery parts has been so considerably accentuated by the development of the motor-car industry that those directly interested are under obligations to the author for the publication of the comprehensive experiments in his paper, especially in connection with the practical side of the work.

With reference to the steel employed, it is, however, to be regretted that no sample of the special case-hardening steels that have been devised has been dealt with, such as chrome-vanadium and special nickel steels. These are intended to supply materials which, while having a hard surface, and being amenable to water-quenching, possess an internal portion in the case-hardened pieces much surpassing in static strength ordinary mild steel, and at the same time being fully equal to it in resisting dynamic stresses. The following results of tensile tests on two samples of steel, case-hardened approximately to the depth of $\frac{1}{20}$ of an inch under closely similar conditions, may be interesting. The casing after quenching was ground away and the cores tested statically. Both samples are standard steels manufactured by Messrs. Willans & Robinson, Ltd., at Queensferry.

	Yield Point. Tons per Sq. In.	Ultimate Stress. Tons per Sq. In.	Elongation on 2 Ins.	Contraction of Area.
1. Mild steel	20·42	32·36	Per Cent. 34·5	Per Cent. 54·2
2. Chrome-vanadium steel .	34·13	45·75	22·0	61·6

The figures yielded by the above special steel denote a strength generally desirable in machinery parts, subject to considerable variations of stress. The illustration below is of a piece of chromium-vanadium steel cased and hardened along with No. 2, of which the casing was ground away and the piece bent double cold, showing plainly the toughness possessed by such an interior.

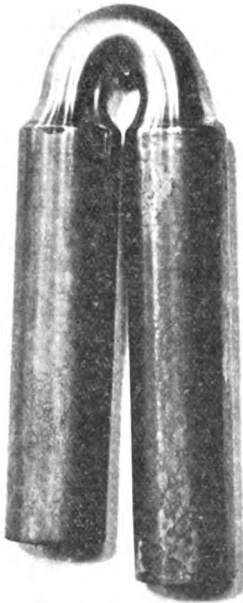

It would seem that, consistent with suitable toughness and ease in casing and quenching, the ideal steel is one that will eventually display in quality of core the minimum of divergence from the strength of the external portion, it being quite conceivable that under torsion or bending stresses incidental to the running of automobiles the distortion of a soft core might the more readily take place with disastrous results to the casing.

The sample used in Mr. Scott's experiments is stated as having contained 0.08 per cent. of sulphur. Viewing the matter from the standpoint that the casing is to consist of steel saturated with carbon (that is, 0.90 per cent.), such a percentage of sulphur is not compatible with a high quality steel suitable for extreme quenching and resistance to shock, involving as it does the presence of numerous isolated spots of manganese sulphide, and ferrous sulphide.

The question of "case-hardening mixtures" is treated in a very interesting manner, and provides a useful means of making a selection. It could be desired that makers of such material would regulate their methods of preparation to yield a product of more uniform composition than is at present the case. The writer's attention was recently called to an instance in which a material was used for trial under a guarantee by

sellers to give very rapid casing. Though the usual venting was allowed for, the immediate result was the bursting of the heavy cast-iron casing pot. The material on examination appeared to be largely composed of "brewers' grains" uncharred, yielding 10 per cent. of moisture and 25 per cent. of volatile matters, when heated to about 200° C., the apparent charring point.

Regarding fineness of material, the writer finds that the layer immediately in contact with the piece to be cemented should be in pulverised form if regular casing is to be obtained, and where slight depths are required. The necessity of this condition is made evident by taking longitudinal sections of a lightly cased bar where the carbonising material has not been in small grains of fairly uniform size. This also applies to such articles as ball races, cones, the periphery of toothed wheels, &c., where uniform hardness is absolutely necessary.

The experiments relating to the theory underlying rapid case-hardening at a moderate temperature are both ingenious and interesting. On comparing the results stated in the first table included in the section headed "Influence of Time and Cementing Material on Case-Hardening" with those given in relation to the last experiments under "Nitrogen and Case-Hardening," it is, however, to be noted that at identical temperatures for similar times sugar-charcoal (non-nitrogenous) has given a penetration of 1.44 millimetres as against 1.58 millimetres with burnt leather "A" and 1.07 millimetres with wood-charcoal in the earlier experiments, which figures, errors excepted, do not emphasise the special importance of nitrogenous matter.

The fact that "once used packing," *i.e.* charred leather, is not to be relied on for a second regular casing under usual conditions is a simple testimony of the valuable effect of the volatile material in the mixture. The process of casing includes among its stages what is practically a dry distillation, and from a complex substance such as charred leather it is of course quite possible that many gaseous carbon compounds may be developed in the box favourable to reaction with the surface of the steel. However, the question of the comparative inertness of the medium used is of importance. This is

exemplified in the author's experiments dealing with the relative casing values of sugar-charcoal and coke. Practical work generally shows that speed of casing at a standard temperature of 900° C. is greatly dependent on the "lightness" of the material used.

Fig. 4 in the paper is specially interesting as showing the danger of "chipping" induced by lax conditions of case-hardening. Though not quite apposite, the writer would mention that he was asked recently to diagnose the reason as to why an 8-inch case-hardened spur wheel chipped under slight shock while not being brittle as a whole. He anticipated a supersaturated cemented bar external structure. Micro-examination, however, revealed an "airing" evidently due to re-heating having taken place under strongly oxidising conditions, carbonless patches with strongly-marked intercrystal-line junctions being found. It is to be hoped that the author will extend his experiments, if he has not already done so, to dealing, among other things, with those very important sides of case-hardening, the re-heating and quenching, the structure developed, and the degrees of hardness conferred.

Mr. G. SHAW SCOTT wrote in reply that whilst being in complete agreement with Mr. Schlindler as to the necessity for exact investigations into the various questions arising from the case-hardening of motor-car parts, he would like to point out that his experiments were intended to cover as wide a field as possible. Hence a brand of ordinary mild steel, similar to that generally used for case-hardening in engineering works, was selected for the purposes of this research. It was certainly most desirable that a thorough investigation into the case-hardening of those special steels used for automobile construction should be made, and the author was grateful to Mr. Schlindler for his suggestions in that direction.

THE ANNUAL DINNER.

THE Annual Dinner of the Institute was held in the Grand Hall of the Hotel Cecil on Thursday, May 14, 1908. The President, Sir Hugh Bell, Bart., presided over a gathering numbering close on four hundred persons, and amongst the noblemen and gentlemen present were the Right Hon. Sir Edward Grey, Bart., Principal Secretary of State for Foreign Affairs; the Viscount Ridley; the Lord Leith of Fyvie; the Lord Allerton, P.C.; the Lord Glantawe of Swansea; the Lord Joicey; Sir Walter Runciman, Bart.; the Right Hon. John L. Wharton; Sir William Thomas Lewis, Bart., Vice-President; Sir William White, K.C.B.; Sir William Matthews, K.C.V.O., President of the Institution of Civil Engineers; Sir Hugh Gilzean Reid; Sir George Gibb; Sir Walter Plummer; Mr. R. A. Hadfield, Past-President; Mr. E. P. Martin, Past-President; Mr. James Riley, Vice-President; Captain H. W. Richmond, R.N.; the Venerable William Sinclair, D.D., Archdeacon of London; Mr. Charles Trevelyan, M.P.; Mr. Herbert Samuel, M.P., Under Secretary of State for the Home Department; Lt.-Gen. R. S. S. Baden-Powell, C.B.; Colonel R. E. Crompton, C.B., President of the Institution of Electrical Engineers; Mr. W. H. Bleckly, Hon. Treasurer; Mr. P. C. Gilchrist, F.R.S., Vice-President; Mr. Arthur W. Fox, C.B.; Colonel T. G. Poole, V.D., Mayor of Middlesbrough; Mr. W. Beardmore, Vice-President; Mr. James Dixon, Chairman of Lloyd's Register; Mr. A. Tannett-Walker, Vice-President; Mr. Arthur Cooper, Vice-President; Mr. Alfred James, President of the Institute of Mining and Metallurgy; the Master Cutler of Sheffield; Mr. George Ainsworth, Member of Council; Mr. T. Hurry Riches, President of the Institution of Mechanical Engineers; the Master of the Worshipful Company of Ironmongers; Professor H. Bauerman, Hon. Member; Dr. R. T. Glazebrook, Director of the National Physical Laboratory; Mr. J. H. Amos; Mr. J. E. Stead, F.R.S., Member of Council; Mr. A. Lamberton, Member of Council; Mr. Iltyd Williams, Member of Council; the Hon. A. E. Kitson; Mr. E. J. Ljungberg (Sweden); Sir Joseph Leigh; Sir John Rolleston; Sir Ralph Littler, K.C., C.B.; Mr. John Gillespie (Calcutta); Mr. W. R. Webster (Philadelphia); Mr. Thomas Cantley (Nova Scotia); Mr. Benjamin Talbot, Bessemer Gold Medallist; and the Chevalier C. de Schwarz (Liège).

The PRESIDENT gave the toast of "His Majesty the King, the Patron of the Iron and Steel Institute."

The PRESIDENT then gave the toast of "Her Majesty Queen Alexandra, His Royal Highness the Prince of Wales (Honorary Member), the Princess of Wales, and the other members of the Royal Family."

Sir WILLIAM H. WHITE, in proposing the toast of "Shipping and Railways," said the toast was, he thought, a new one on the list of toasts given at the dinner of that Institute. These two interests were, next to agriculture, the greatest of our national interests, and he might also say that two of their best customers, the customers of the Iron and Steel Institute, were railways and shipping, so it was quite clear that the toast was appropriate, and would be given a very hearty reception. There were certain points of resemblance between shipping and railways, and there were also points of very marked difference. They were both of them engaged in that great work of transport and inter-communication, which not merely dealt with the development of commerce, but greatly influenced the international relations of the world, because, to achieve that intercourse, the easier and cheaper the communication, the more readily nations got to know one another, the fewer chances there were of prejudices existing and of ill-feeling being created. That day, at the Franco-British Exhibition, there had been a display of international good feeling which he was sure they were all of them delighted to have witnessed, and His Royal Highness the Prince of Wales, in the short but very excellent reply to the address presented to him, touched upon the vital points of value in that Exhibition as a means of promoting good feeling between two great and neighbouring countries. Then those two interests had another feature of similarity at the present time. They were neither of them in a very flourishing condition, judged from the point of view of dividends to shareholders. He did not mind telling them, in confidence, that he had no shares in shipping, but he would like to add that that was to be explained quite readily by the fact that a public servant never had much money to invest in anything. The little he had was largely invested in railways, and he could only say he looked forward with some anxiety to the future. At the same time he felt quite confident that it was only a temporary cloud which was overhanging these great industries, and that out of the trouble would come even greater successes than had ever yet been attained, and that the Iron and Steel Institute would benefit thereby. Railways and shipping not merely resembled one another, but they were very closely connected with each other, and in some of the Colonies there was no disguise as to that intimate connection among railway companies who owned great fleets. In other countries there was an intimate connection between shipping and railways, even where the railways were not owned by private companies but by the Government, a connection which was not quite fully disclosed, and those railways affected, and seriously affected, British traders in competition. But against that and all other forms of competition, Great Britain was quite equal to holding its own. He did not believe Great Britain was as backward in the race or in educa-

tional appliances, or in manufacturing capability, or in hope for the future, as some would have them believe. The English-speaking people were too fond of decrying themselves. He thought what was wanted was sometimes to turn over a new leaf, and to blow the trumpet a little for a change. He had just been to America, where they were going through a phase of self-depreciation which was neither wholesome nor satisfactory, yet he had felt the cry to be familiar because he had been accustomed to hear the same thing at home. It was not wise to pose in that fashion. It was not wise to issue in British publications statements which would be translated and published throughout the world by rivals as trade advertisements. It was not wise to enable a competitor to say that such and such was the settled opinion of the British public as to its future, or of the British manufacturers as to the industrial outlook. It did not affect shipping and railways alone, but a great deal more than that. As to the differences between shipping and railways, there was one most important fact in a ship's movements through the water that perhaps they had not always recognised as fully as he did, and that was that a ship was always going up hill and never down hill. There might be a trifle of tide in its favour, but not enough to count. A railway mounted and fell; it climbed the Shap summit and ran down again towards Carlisle. The engine made a great effort in mounting but got relief in coming down, but the poor ship was always doing collar work. He had just come from America, and he had crossed at a speed which, for three days on end—until they came where the weather would no longer permit of it—reached twenty-eight statute miles per hour, which he thought compared favourably with the performance of some railways. He had known railway journeys on lines which were considered to be first class, which did not average so much as that, allowing for up hill and down hill. He remembered when the "Flying Scotsman" began to make its marvellous runs, and the account published in the *Times* of that period. A few days afterwards there came out in the *Pall Mall Gazette* another article entitled "The Flying Watkin." He would not enlarge upon the latter performance. He would only say he was confident it did not average nearly 28½ miles per hour, nor was it kept up continuously for 2000 miles. Railway men, when they had a straight run of 200 miles, considered they had done a wonderful thing, but what must feats of 3000 miles to 6000 miles on end without a stop be considered, up hill all the way? They would see that he was blowing his trumpet now as a naval architect. Without the iron and steel manufacture, however, shipping and railways would not be what they were. When he read of the marvellous progress that had been made in Great Britain in recent years in railroads, mining engineering, and the manufacturing of iron and steel, he could not forget the debt of gratitude owed to the latter. It could not be claimed for British railways that they had half the mileage of the world in Great Britain. That was impossible. But it could be claimed for shipping that more than half the tonnage of the world was built at home. There was

plenty of room in the empire for railways, and the British capitalist would do better to devote his wealth in helping forward the development of the British dominions beyond the seas than in helping foreign countries to develop. While there was such scope within those dominions, there was no need ever to despair that British railways and British shipping would continue to flourish. He had to couple with the toast the names of two distinguished guests—the Right Hon. John Wharton, the Chairman of the North-Eastern Railway Company, and that of Sir Walter Runciman.

The Right Hon. JOHN LLOYD WHARTON in reply, said he felt most sincerely the honour done him in asking him to return thanks for that very important toast. He had only to reply on behalf of the Railways; the other half would be worthily dealt with by Sir Walter Runciman. A few months ago, that toast would have been a more difficult toast to reply to than it was at present; as at that period there had been a somewhat serious outlook for railway companies in general. He was glad to take that opportunity of expressing his thanks to the late President of the Board of Trade and present Chancellor of the Exchequer for the part he took, which was largely contributory to peace between employers and employed. He was not aware whether many in that room had seen a pamphlet which had been circulated by that very large and influential body, the Amalgamated Society of Railway Servants. If they had, they had seen a document which gave the railway companies of England as good a character as they could possibly have, out of the mouths of those they employed. When they heard stories about programmes to be put forward and carried out, he believed the common-sense of Englishmen would prevail, and that the employees of the railway companies, when they really looked into the matter and thought for themselves, would see that their employment was one which they could not lightly surrender. It was an employment which was continuous, and that could not be said of every employment in England. It was said that there was only an average wage of 23s. a week among railway employees, but that included boys as well, and an average of 23s. a week year in year out for the best part of their lives was not a thing the men were likely to surrender. He might be an optimist or over sanguine, but he would repeat that he believed the common-sense of Englishmen would prevail, and what seemed likely some few months ago would not again come to the front in the way that it had done before, and that there would be peace between employers and employed. With regard to a matter which he considered to be a very important matter indeed, he wished to say that he did not believe there was the force behind the attempt at what was called "nationalisation" that some people imagined. He would nevertheless like to ask every one in that room if they could believe that if the nationalisation of the English railways was carried out, if the railways ceased to be controlled by the Boards of Directors and the officials who now controlled them and were to be handed over to State control, that the individual would benefit? Did they think that the trader would benefit, or that the

shareholders of the railway companies would benefit, or that Great Britain at large would benefit? He honestly believed that the best thing for England was that railways should continue in the hands of those who now guided them, and guided them in a way which he believed no other nation on earth succeeded in equalling. There might be one other person who would be somewhat interested were this nationalisation to take place. The labourer was worthy of his hire, and whosoever might occupy the position of President of the Board of Trade would have a better salary in the future than he had had in times past; but if he was to become general manager of every railway in the United Kingdom, he did not know what should be paid him. He thought £10,000 a year would be insufficient. If they sought the welfare of Great Britain the railways should remain under their present management, and he believed they would flourish, and that they would benefit the trader, and the iron and steel trades especially. They were far better off under the present management of railways than they would be were that to be turned into State management as some people suggested. Those present were members of the great industry of iron and steel, that it was to their interest probably more than to that of any other industry in England that railways should be well managed. When the time came, if it ever did come, when they would approve of any alteration in the management of railways, he hoped they would give a good character to those who at present controlled them.

Sir WALTER RUNCIMAN, Bart., M.P., said that a very able naval architect had told them that he had no shares in shipping. He would recommend him to take a few and he would very quickly get to learn how to live upon his losses. They were passing through a phase of very severe depression. He dared say they knew as much about it as he did in the different trades in which they were engaged. He did not think that those depressions were an unmixed blessing. Trade was as certain to have depressions as it was to have booms, and while they were going through the phase of depression, they might depend upon it that it had the useful effect of causing them to exercise the resources of their minds and good results would ultimately be derived from it. They had travelled far since those primitive times which Sir William White referred to when he (Sir Walter) was going to sea in a small sailing ship. They had ships now of which they could hardly tell one end from the other. He did not think that the proposer of that toast had anything to do with the designing of them, but at any rate they had that useful purpose in that they brought good to the people of Great Britain. They had to be very careful that they did not touch that great industry. He would remind some of the members of the Government present that each successive Government had not been unmindful of this great industry—not in subsidies, but in Acts of Parliament. As many as twenty-one Acts of Parliament had been passed in twenty-one years, and he thought fifty Acts of Parliament had been put into the 1897 Act. That was not a bad record for twenty-one years. He had said

they were passing through a period of great depression in shipping, dear coal—Lord Joicey knew something about that—dear provisions, dear insurance, dear everything, but they were able to compete with the other nations of the world independent of subsidies, and it was a very remarkable thing that the great bulk of the shipowners of this country did not want subsidies. They were able to compete. When there was work to do, they were able to pay their dividends irrespective of it. Other countries—France, Germany, and Austria—were subsidised countries, yet Great Britain kept pace with them. They ought to be very proud of that great shipping industry, and he hoped that before the autumn—he was not going to predict that they were going to have a better time than they had been having—but that they would have a better time than had been predicted by a writer in the *Morning Post*, who had occupied a column and a half in inveighing against the shipping interests of the country. He had replied to that letter as well as he could, and he had told that correspondent that he knew nothing at all about it. He thanked Sir William White for proposing the toast and those present for the cheerful way in which they had received it.

Mr. R. A. HADFIELD, in proposing the toast of the guests, said they had received from one of their guests, Sir Walter Runciman, some exceedingly excellent advice. At a time like the present, when some of them were perhaps rather pessimistic, it was very encouraging to meet an optimistic speaker. He thought the turn of the tide would come before long, and he hoped they might look forward before long to a change in the conditions of trade. He had the pleasure of coupling with the toast two very well-known names, those of Viscount Ridley and of Lieutenant-General Baden-Powell. In Lord Ridley they had one who had done good service in the past; while they all remembered the services that General Baden-Powell had rendered on the battle-field. They had also present with them that evening a very distinguished guest—a guest whose name was a household word—Sir Edward Grey. He (the speaker) came from Sheffield, and there was only one fault that city could find with Sir Edward Grey, and that was that he had not contrived what he might call a little “shindy.” If he did so, Sheffield would be very thankful to him. He would say at once that such a shindy should not be with any mundane country; but it might be with Mars. Sheffield had built up a great industry in order to protect the Empire. The Budget revealed an income last year of £160,000,000, yet the government appeared to grudge building a battleship or two. He was sure he would be forgiven for reminding them that the Empire could not afford to run any risks, and Sheffield for one did not want to see the defences of the Empire run down. He had much pleasure in calling upon those present heartily to drink to the toast, coupling with it the names of the gentlemen he had named.

Viscount RIDLEY said he realised he was one of the guests of a distinguished Institute, whose works accompanied them from the cradle to the grave, without which they could not live, and one

which had been responsible in the past century for the creation of what he might venture to term the second Iron Age. Though the Iron and Steel Institute might enter into the manufacture of nearly every article, there was one commodity at least which was not made of iron and steel, and that was the human frame. They thoroughly appreciated the privilege and the pleasure of dining with that distinguished Institute, but when he reflected upon what to return the compliment which they did them, he remembered the motto that "Speech is silver and silence is golden." As one of their guests, he ventured to repay their hosts in the most expensive metal at his command, by that silence which was equivalent to gold.

Lieutenant-General R. S. S. BADEN-POWELL, C.B., said it was a very difficult task indeed to return thanks for the guests after such speeches as they had heard, and indeed he hardly knew who the guests were, or why they were there. He was dining some nights previously at a dinner of a very old-fashioned institute called "The Set of Odd Volumes," and at that table it was the custom of the President to ask each member after dinner who his guests were, and when the member had explained, he was asked, "And why did you bring them here?" However, in the present instance he did not think the guests cared very much why they had been asked, provided they were asked. Speaking for himself, he was very glad to be there, and he felt it a great privilege to meet those whom he might call the kings of commerce or the great alchemists of the age, those who were turning iron into gold—or at least he hoped they were doing so. It had very long been his privilege to belong to that little steel ring that endeavoured to secure peace for the carrying out of those interesting chemical experiments, that ring with regard to which a man who was shown much gold said, "Yes, I saw the gold, but I did not see the iron with which to protect it." That reminded him of the words of the Scotch ballad—

'But what is the good of your store of gold,
If you have not the steel to guard it and hold.'

At the moment he had the privilege of belonging to the new strengthening link of steel that was now being forged to defend the Empire, and he wished to take the opportunity of thanking those employers of labour who had so loyally taken up that cause, and helped them so efficiently in giving it a fair hand and a good start. No doubt doing so they were doing themselves a good turn also, because it was a form of insurance which could not be without its value in the end. But at the same time the military authorities felt it a very great help, just at that particular juncture when efforts were being made to get officers and men, that the employers should come forward to help men to take service in the new Territorial Forces. From that point of view, he was personally very glad indeed to have the privilege of being there that night.

The Right Hon. Sir EDWARD GREY, Bart. (Secretary of State for Foreign Affairs), said: One of the disadvantages, I should say the only disadvantage, of being placed late on the toast list has already been exemplified this evening in Lord Ridley's speech. It is that there is a tendency on the part of previous speakers to abbreviate their own remarks under cover of expedition because one of the later speakers is going to make a long oration. Well, gentlemen, I am in the position of disadvantage that, speaking as I do now, I can safely say that we have arrived at that period of the evening when you do not desire any more than I do on any occasion, that I should realise the expectation of making a long speech. But I am grateful to your President and to you for having entrusted me with this toast, because I would say how much I appreciate the value and the great importance of the industry with which this Institute is connected. It is an industry so closely connected with all the most essential parts of our national life that its prosperity is in some sense a barometer of the whole national prosperity. Your Institute does valuable work by continually encouraging invention in promoting research, in contributing to the progress of the industry, and in insuring, by the diffusion of information, that the progress of that industry should be distributed universally. It is interesting work and it is important work, but it is also highly technical work, and as even a politician may sometimes feel that it is best to confine himself to learning his own business and to be wary of attempting to teach other people theirs, I would in proposing this toast not attempt to go too closely into matters with which you must be much more intimately acquainted than I am, but confine myself to a few of those observations of a vague and general character, of which all politicians, and especially Foreign Secretaries, keep a large stock in hand, and which, as far as I am concerned, are much suited to the comparatively unsubstantial metal of concerts and halls with which I have to deal than they are to that durable, strong, and solid material which is the object of your particular interest. I am glad to know that in this Institute there are many foreign members, and that your objects are so excellent, so uncontroversial, so absolutely non-political that you can indulge in cosmopolitanism without laying yourself open to any reproach. I was glad that Sir William White took the opportunity of referring to the opening of the great Exhibition, which is in itself an instance that industry does promote rivalry amongst nations, and also in better aspects promotes concord and good fellowship. But it is not so easy as it was, to speak on industrial matters and yet to avoid controversial questions. In industry especially we have to be careful how we speak on non-controversial occasions at the present time. There are those who are ready to discuss questions involving a physical revolution, and there are those who are ready to discuss questions involving a social revolution. All controversial matters of that kind I would put on one side. But this much I think I may safely say, that industries have to-day politics which are peculiarly their own and with which they must deal themselves, and with which,

unless they deal with them satisfactorily, not the best government in the world can safeguard the interests of the country. The politics of industry to-day are intimately concerned with the relations between employers and employed, each of whom are essential to the prosperity of the industry in which they are concerned. Their community of interest is fundamental. The divergency of their interest is superficial, but, as it is so often the case in life, the superficial is more obvious than the fundamental. What we seek to promote to-day is that the feeling of unity of interest between employers and employed should be brought home not merely to the intelligence of the country but to the feeling of the country. That is by no means the same thing. The action of the intelligence in all human affairs is not without effort. It is deliberate and it is intermittent. The action of the feelings is without effort—it is spontaneous and continuous—and that is why argument will never settle these questions, and why good relations between those different classes concerned in the industry must depend very greatly, not upon argument, but upon the tone and the temper in which they are handled by the two interests respectively. I have, at any rate, had enough connection with business to know that even between employers in the different industries there is a real community of interest, but the superficial, which is divergent, is sometimes more active than the fundamental, which is the community of interest. I have recognised to-night with great pleasure how Sir William White emphasised, apparently with your approval, the community of interest between railways, shipping, and the iron and steel industry, but I think everybody who has had connection with railway work must have known occasions when, in the inner councils of railway managers, regret has been expressed that that community of interest between other important interests and the railways did not seem so apparent to the industries served by the railways as it was to the railway managers themselves. So that I trust you will take my remarks as to the necessity of emphasising unity of interest as being confined not solely to employers and employed but as also being applicable to the different industries. With regard to the Government, to which I must briefly refer after what one or two of the speakers have said, notably Sir Walter Runciman and Mr. Hadfield. I have not noticed to-night any great demand for legislation. Sir Walter Runciman, it is true, said with great satisfaction that the shipping industry had survived, I forget how many Acts of Parliament; but he did not express, as I gathered from his speech, a desire for any more Acts of Parliament. I warmly welcomed the tone of Sir Walter Runciman's speech. He began by discouraging Sir William White from investing in shipping shares, but when it came to the end of his speech, I think Sir William White must have felt that if he had never hitherto entertained the idea of investing in shipping, now was the time to do it. I would not underrate the importance of good legislation to the material welfare of the country, but I recognise that from the immediate point of view of the great industries, what you wish to have from

a Government is good and sound administration. In this country, if you take what is the true standard of judging Governments, the comparative standard, and compare it with the administration elsewhere, we might safely say that we have on the whole enjoyed under successive Governments exceedingly good administration. We did not secure it in a logical way, but then we never secure anything in a logical way. A man in public life wins his place by eloquence, heroics of party politics, by proficiency in the use of words; and having won his place, he finds himself at the head of a great Department where his business is not heroics at all, but the humdrum details of administration, and where, especially, as in my Department, on most occasions, the less he makes use of words the better. But it is a system which I believe on the whole has succeeded, and will continue to succeed, in bringing to the top and associating in the government of this country, men of strong intelligence, who are well fitted both to cope with the rough and tumble of political life, and to turn their hands to good effect in the administration of important offices. Amongst those offices the Board of Trade is one which will become of increasing importance. The demands upon the Board of Trade will be more continuous than ever. They have been demands—I would not say for interference, because interference is often resented, but for intervention, which is often exceedingly welcome. I will claim this on behalf of the present Government, and I am exceedingly glad that Mr. Wharton has justified me, in the generous way in which he has done so, in adding to his remarks by saying that under the present Government—while Mr. Lloyd George was at the Board of Trade—the Board thoroughly maintained its high reputation. I think it has added to its great traditions, and that it was administered with a discretion, tact, and impartiality with regard to labour disputes which are essential to maintaining the position of the Board which, in the long run, must depend for its utility upon its possessing the confidence of all classes of the community. But if the Board of Trade is in the forefront of administration with regard to industries, the Department with which I am immediately concerned is also connected with industries, although it is in the background. Here I feel I am on delicate ground after Mr. Hadfield's speech. I had intended to say that the main business of the Department, as far as industry is concerned, is to promote peace. Mr. Hadfield dilated on the indirect advantages of war. I feel I must still contend that the important business of the Foreign Office is to promote peace. It is true that the iron and steel industry has two great branches, one of them concerned with making the instruments of production, and the other concerned in making the instruments of destruction. It is true that in times of war the iron and steel industry does have what has been called to-night "a boom." But a boom is not the same thing as prosperity, and if a shindy can produce a boom, it is peace alone that can produce prosperity. Therefore, as far as wise government is concerned, it will do its utmost to produce such a condition of affairs in the iron and

steel industry as will concentrate itself upon producing the machinery for the mercantile marine, the various implements used in industry, every one of which in its use helps to reproduce the capital which has been consumed in creating it. If, unfortunately, peace cannot be preserved, and if you have that boom which comes from great expenditure upon armaments, you must in the long run suffer, because the instruments which you are producing instead of reproducing capital will be used to destroy capital. Peace unfortunately is not as cheap now as it once was. The burden of armaments in Europe and the world at large is becoming greater and greater. Increased taxation diminishes the profits of industry; borrowing takes away the capital, which is one of the springs of industry. Desirable as it be that expenditure and armaments should be reduced—desirable for every nation—one nation can do nothing in this direction without the other; and if Mr. Hadfield is anxious to be assured that the importance of maintaining our armaments sufficiently strong to protect this country is realised by the Government, I will say this, that we do realise, much as we wish to reduce expenditure, that our naval expenditure in particular is, and must remain, dependent upon the naval expenses of other countries. I wish nations would be equally ready to recognise their community of interest as employers or employed in other industries. But until they do recognise that their naval expenditure will be dependent upon that of one another, I do not see how you are to make progress in the reduction of armaments. We do not recognise that, and we frankly admit that it is so, and we are ready to meet other nations in discussion if they will equally admit it. But the British Navy is purely a defensive force, and for that reason an essential force, and if our naval position falls to such a point that it is unable to cope with any other combination which can be brought against it, it will not merely be our prosperity that will be at stake, but it will be our very independence and integrity.

I will ask leave, in proposing this toast, to join with it the name of Sir Hugh Bell, who can speak to us with authority, weight, and knowledge on the subject of industry. I do not imagine that you could have had a more favoured President than Sir Hugh Bell. His own personal connection with the Institute, and the connection of his father before him, his connection not only with the Institute but with the industry, must be historic and treasured in the traditions of the iron and steel industry. For myself I would add this, that it adds to my pleasure in proposing this toast that I should be able to couple with it the name of a man whom I value as highly as I value Sir Hugh Bell. We have been colleagues in business, we have met on many occasions, we have discussed many things together, we have discussed politics and business, and many branches of worldly affairs, and on all these occasions I can say with confidence that I have gained more than he has gained. That is an observation which I will ask him to take not as any reflection upon his business ability. To all of us who know him, we know that he brings into everything that

he does an unusual amount of energy and thought, and that he brings to all that he does and all that he says an amount of vigour and freshness which makes it a pleasure and an advantage to work with him. I ask you to drink the toast of the Iron and Steel Institute, coupled with the name of Sir Hugh Bell, your President.

Sir HUGH BELL, Bart., in replying, said: Sir Edward Grey, my lords and gentlemen, it is indeed a very great honour to be permitted to preside over such an institution as the Iron and Steel Institute, but on no occasion does that distinction come more closely home to one than on such an evening as the present. I will claim for the Institute that never during its existence has its dinner been marked by more distinguished speeches than we have heard to-night. If I were asked to say what was that particular mark which differentiates them from the ordinary after dinner speeches such as one hears when one goes to a public dinner, I would say that it was their discreet indiscretions. One speaker after another has skated up to the very margin of the thinnest ice. No single one has let his iron pass into the water beneath him by a hair's-breadth. My friend, Sir William White—I trembled at moments during his observations—I thought in another second he would be over the edge, and we should have to drown him in applause. But no! He turned away, was off in another direction, and the danger was avoided. Again, the gentleman who followed him, the Chairman of the North-Eastern Railway Company, was as close to danger as it was possible to get without actually incurring it, and yet I think no one will deny that the words used by Mr. Wharton were of infinite value in the situation in which we find ourselves. My friend, Sir Walter Runciman, who, with his advice to Sir William not to invest, and his concluding remarks that the best thing you could do with your money now was to put it into shipping, was characteristic of the indiscretion of language which I believe is almost inherent in the captain on the bridge of a steamer. Then I come to the next on the list, Mr. Hadfield, who invites the Foreign Secretary to "kick up a little shindy." If it had been anybody but a man from Sheffield, one would have said that that was a blazing indiscretion. Oh, no! Mr. Hadfield turned aside and took the opportunity of saying some words to which I shall advert at a later stage. My friend, Lord Ridley, was, I could see, burning to emit opinions which on one hand would have elicited no little applause from some gentlemen in this room, but, on the other hand, would have called forth signs of dissent which would, I hope, have fully overwhelmed those of approval. Then General Baden-Powell, who calls us, in delicate language, all the names he can lay his tongue to for asking him to dinner, tells us precisely why we did it. Perhaps you did not follow exactly what General Baden-Powell was saying. I will tell you why he is one of our most honoured guests this evening. Among other capacities (so numerous I almost feel inclined to imitate Mark Twain, who you will recollect intimated that he had enlisted so many times in America that he thought of calling himself out and electing himself colonel of the regiment of

which he was the sole private soldier), I am more or less in the position of being responsible for some small section of the Territorial Army to which General Baden-Powell in veiled terms was referring, and he is my general in command. Is it surprising that I should desire to conciliate him? If I am not successful, the chances are ten to one he will have me out in the barrack-yard and shoot me! Then finally, Sir Edward Grey, with the discreet indiscretions of a Secretary for Foreign Affairs that were perfectly delightful to listen to! The way in which he was able to point out to Mr. Hadfield where the true interests of our industry are to be found, must have warmed the hearts of all of us. My lords and gentlemen, the iron industry is the industry of peace, and if it is the means of warfare, if it supplies the means of warfare, in this country at all events we believe and hope it supplies the means of warfare for the sake of peace.

My lords and gentlemen, on your bill of fare there appears for the first time a coat of arms. Up to now we were content to emblazon on our official documents the head of a very distinguished English gentleman, a great nobleman, and a personage to whom the Institute owes much, the seventh Duke of Devonshire. Now, even a duke is not necessarily beautiful, and a duke's head is not necessarily an ornament. The Council have permitted me to put the Institute into the position of having the right to wear coat armour: to bear arms. If any body of men are entitled to armour, surely it is the Iron and Steel Institute. Sir Edward Grey has referred to the very many qualifications and to the multitudinous knowledge required in the iron and steel industry. I have no doubt there is not a single man in this room who cannot blazon the arms printed on the back of the bill of fare and who would not at once in chorus say after me—

“Sable, a Buck's head caboshed, and in chief two Hawks' bells Argent on a chief Rayonne Or, the astronomical symbol of Mars of the first.”

May I venture to call your attention to the symbolism of the coat? By heraldic convention, black is the sign of your metal, the stag's head represents the Duke of Devonshire, your first President; the heralds have been good enough to put on to your shield something recalling the fact that my father was connected with the founding of your Institute—the Hawks' bells; while the chief Rayonne Or indicates the method by which you transmute the base metal into the precious commodity, which after all is the end of our ambition, the gold of your chief. The chief bears the symbol of Mars, the alchemic sign of your metal, iron. So I venture to think the Arms are not inappropriate to the Institute, but I will add that the motto appears to carry into heraldic parlance that sentiment by which you justify your corporate existence, “The smith helps the smith;”—the ironmaster helps the ironmaster. It takes two of us to do anything that we require to do. That, as Sir Edward Grey has well pointed out, is the purpose for which the Institute exists. I hope you will

think we have been rightly guided in the selection of your Arms. Let me say once again that the mark of your industry is not war but peace. It is from peace that you will derive that prosperity on which the prosperity of the world largely depends, and without which the industry cannot be satisfactorily carried on. We may thank Sir Edward Grey for having drawn our attention to the fact that the industry must be carried on in no selfish spirit. Indeed all industry bears the mark of mutual advantage, without which it would not continue to exist. I cannot sufficiently thank Sir Edward for the kind terms in which he referred to the personal relations which have existed between him and myself, but I will take exception to his having found it necessary to make any caveat that from that intercourse he had gained more than I. It is a sorry interchange even of thought, and much more of commodities, where there is not a mutual gain, where each party to the bargain does not go away better for the interchange. I will assure Sir Edward that if he has gone away thinking that he has done better out of the intercourse, I, on my side, went away feeling that in so far as there was any getting the better of the transaction, I had got the better of him on precisely the same terms. I do not know whether you observed some few days ago that a distinguished American admiral remarked that what the world wanted was more battleships and fewer statesmen. I dare say those who design and build battleships would be inclined to agree with Admiral Evans in the view which he expressed, but the rest of the world think they are well-advised in holding no such opinion if we can get the right sort of statesmen. If we could have a good many more like Sir Edward Grey, I will venture to assert that we should forge the main part of our swords into ploughshares, and use the money we spend in defending what we have got in making more. That, perhaps, is a counsel of perfection, and I am sure this audience will have been glad to hear from one who speaks with the authority of Sir Edward Grey, that there is no fear of the British sword being forged into a ploughshare until we are quite sure that we no longer require it for the purposes of defence.

I want to go back for one moment to the remarks of my friend Sir Walter Runciman, because I writhed under them and could not stand the gibe which he directed at my Lord Joicey. I am a coal-owner myself, and if I refer to recent proceedings in Parliament I seem rather like getting on to thin ice myself. When I found there were two classes of persons who were going to be excluded from the old age pension scheme, I came to the conclusion that neither Lord Joicey nor I had any chance of getting our 5s a week, because in the estimation of our fellow-countrymen the coal-owners belong to one or the other (and sometimes to both) of the two excluded classes—they are invariably either lunatics or criminals, mostly both. But I will assure you, and I think Lord Joicey will confirm the fact I am going to state, that we do not differ from the rest of you by one jot or tittle. We carry on our industry for the sole purpose of benefiting mankind, and when, from time to time, at long intervals, we derive some little benefit from

it, all we do with the money is to invest it in similar enterprises in order that the world may be made still better off. That is a view just as well justified as those which attribute to us all sorts of malfeasances when they did not accuse us of criminal folly.

I said I was afraid I would really get on to thin ice, and therefore I had better skate away from it as rapidly as possible, and conclude by offering to our guests this evening our very hearty thanks for their presence at our table, and for the kind way in which the toast of the Institute was proposed by Sir Edward Grey and responded to by the rest of the guests. I suppose you did not venture to respond yourselves, gentlemen, for you would never think of drinking to your own very good health. Now our proceedings are at an end, and I hope none of us have transgressed longer on your patience than was fitting, regard being had to the importance of the occasion.

I am reminded by a gentleman in the room that the Autumn meeting takes place in Middlesbrough. We have nothing to do with armaments there. We are purely on the pacific side of the industry, and we will offer you—and I, as a Middlesbrough man, offer to the Institute—a very hearty welcome to Middlesbrough when the time comes.

THE NEW PREMISES OF THE IRON AND STEEL INSTITUTE.

OWING to the steady growth of the membership of the Iron and Steel Institute, with the increasing clerical work thereby entailed, and to the expansion of the Institute Library, which now contains several thousands of volumes, the Council decided, early in the current year, to secure more commodious offices, and to effect certain improvements in the internal arrangements with the object of providing additional facilities for the members. An opportunity fortunately presented itself for obtaining a lease of the spacious offices, in the same building, formerly occupied by Sir Douglas Fox & Partners. The acquisition of these premises presented numerous advantages, amongst which the fact that the address would remain unchanged, had much weight with the Council. Negotiations were therefore opened with the Westminster Trust, who are the landlords of the premises, and a satisfactory arrangement having been arrived at, the Council concluded an agreement at their meeting in February.

The new premises consist of a suite of ten rooms, on the first floor of No. 28 Victoria Street, having precisely the same outlook as the recently vacated offices, and access being obtained from the same main entrance and staircase. The Council have also obtained the use of a storeroom, conveniently situated in the same building, on the sixth floor.

A plan of the new offices is shown in the figure on the next page. The entrance is immediately opposite that of the old premises, and affords access to a spacious hall nearly 70 feet in length. The rooms have been decorated throughout in white enamel, with distempered walls of pale straw-yellow colour, which ensures the maximum radiation of light, and enables an effective display to be made of the extensive collection of portraits and paintings possessed by the Institute.

To the left, on entering the hall, is a suite of five rooms

overlooking Victoria Street. The first room is fitted as a waiting-room, and its most interesting feature is the large show-case containing the collection of early specimens of Bessemer steel presented to the Institute by Sir Henry Bessemer. Amongst other objects of interest on view in this case are short pieces of a 100-pounder gun tube made of Bessemer steel, a 74-pounder steel projectile formed in a hydraulic rolling-mill of novel construction designed and worked by Sir Henry Bessemer, part of a Bessemer steel rail

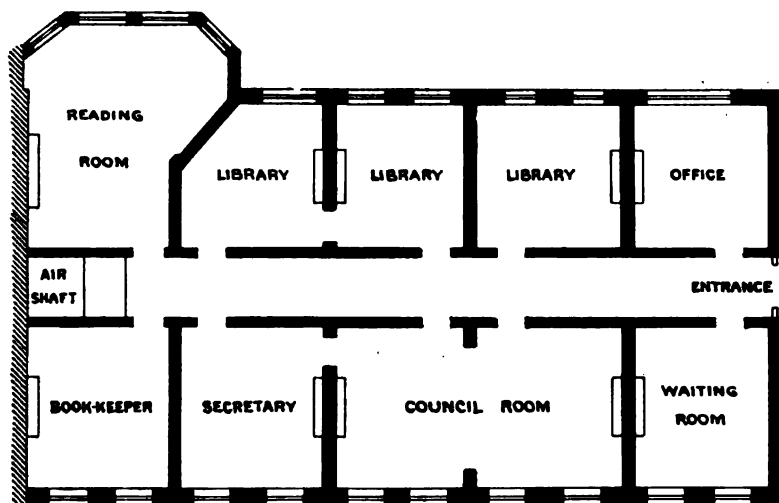

Plan of New Premises.

rolled at the works of the London & North-Western Railway Company, and a portion of a steel rail twisted into a complete spiral from end to end, without producing fracture. Two interesting specimens are pieces cut from the two first rails of Bessemer metal ever rolled, the metal having been made from Blaenavon grey foundry pig at Sir Henry Bessemer's experimental works at Baxter House, London, in 1856. A sample consisting of the earliest experimental example of metal converted by the Bessemer process is also shown, the resulting ingot having been rolled at the Royal Arsenal at Woolwich into a flat bar. This bar was made in about the

month of June 1856, and was among the samples of Bessemer metal exhibited at the meeting of the British Association at Cheltenham on the 13th August 1856. With the exception of this bar, all the other samples shown on that occasion have been lost. There is also a small model gun forged from one of the first Bessemer ingots which were made at the works of Messrs. Bessemer & Co. at Sheffield. An analysis of the metal of which this gun is made was conducted by Mr. Edward Riley, when it was found that it yielded 99·787 per cent. of pure iron, and was therefore equal in quality to some of the highest brands of Swedish bar iron. Another show-case contains a collection of medals and of the badges which have been issued at the various meetings of the Institute.

Suspended around the walls of the waiting-room are portraits of Henry Cort (the inventor of puddling and of grooved rolls), George Thomas Clark (one of the trustees of the Institute, 1880–1898), Alexander Thielen (Vice-President, 1896), and Benjamin Walker (Member of Council, 1889–1890), together with diplomas gained by the Institute at various exhibitions in which it has participated, including those of Paris, St. Louis, and Milan.

The two adjoining rooms have been thrown into one, and form a spacious Council-room. In a prominent position of this room stands a life-sized painting in oils, by H. T. Wells, R.A., of the seventh Duke of Devonshire, the first President of the Institute. At one end of the room is suspended a large oil painting, by Rudolph Lehmann, of Sir Henry Bessemer (President, 1872), at the period of his invention of the Bessemer process. At the other end hangs the portrait, in oils, of Edward Williams (President, 1879–81), presented to the Institute by William Jenkins of Consett. The Council-room also contains the portraits of the Past-Presidents of the Iron and Steel Institute, viz. :—

Sir LOWTHIAN BELL, Bart. (1873–75).

WILLIAM MENELAUS (1875–77).

Sir C. WILLIAM SIEMENS (1877–79).

EDWARD WILLIAMS (1879–81).

JOSIAH TIMMIS SMITH (1881–83).

Sir BERNHARD SAMUELSON, Bart. (1883–85).

JOHN PERCY (1885–87).

DANIEL ADAMSON (1887–89).

LORD AIREDALE OF GLEDHOW (1889–91).

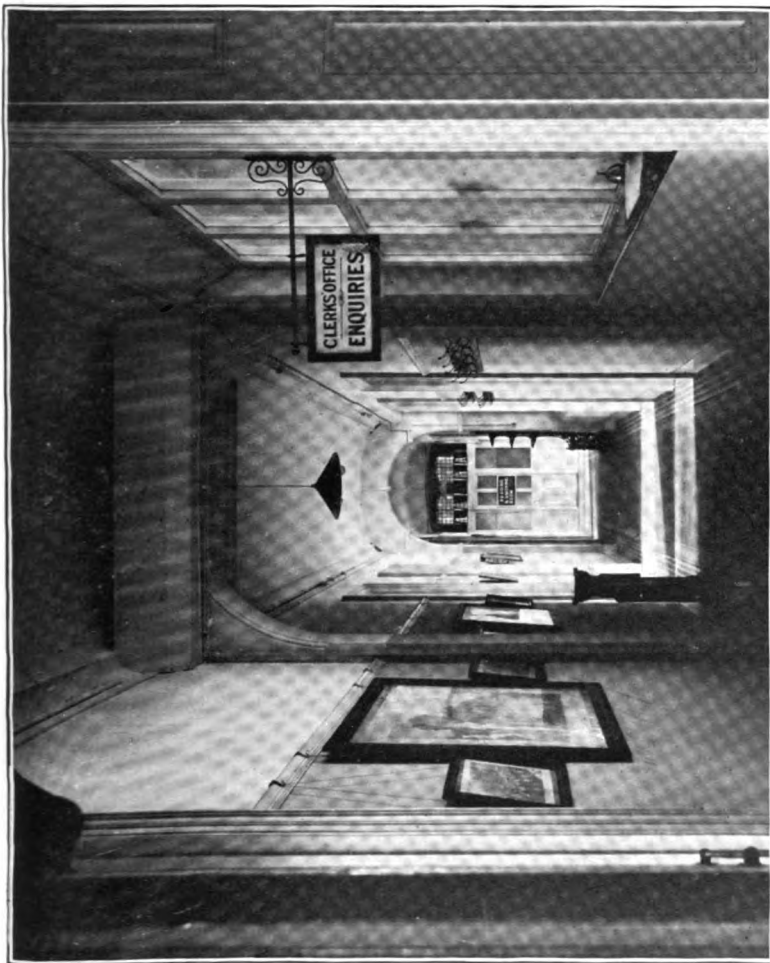

The Entrance Hall, Iron and Steel Institute.



The Council-Room, Iron and Steel Institute.

Sir FREDERICK AUGUSTUS ABEL,
Bart. (1891-93).

EDWARD WINDSOR RICHARDS (1893-95).

Sir DAVID DALE, Bart. (1895-97).

EDWARD PRITCHARD MARTIN (1897-99).

Sir WILLIAM CHANDLER ROBERTS-AUSTEN (1899-1901).

WILLIAM WHITWELL (1901-1903).

ANDREW CARNEGIE (1903-1905).

ROBERT ABBOTT HADFIELD (1905-1907).

The Council-room also contains a portrait of Mr. W. H. Bleckly, Hon. Treasurer, and albums containing a collection of photographs of members of the Institute.

A door of communication from the Council-room affords access to the Secretary's room, while the last room on this side of the hall is used as an office for the Institute's accounts and correspondence. On the western side of the hall is a large reading-room and lounge, in which members may consult current periodicals, conduct correspondence, and meet each other for conversation or consultation. Smoking is allowed, and comfortable lounge seats have been provided, the Council being desirous of encouraging members to use the room as a meeting-place. On the walls of the reading-room are displayed portraits of the Bessemer medallists of the Institute, including—

ROBERT FORESTER MUSHET.

PETER Ritter VON TUNNER.

PETER COOPER.

Sir JOSEPH WHITWORTH, Bart.

ALEXANDER LYMAN HOLLEY.

GEORGE JAMES SNELUS.

SIDNEY GILCHRIST THOMAS.

RICHARD ÅKERMAN.

JAMES RILEY.

JOHN DEVONSHIRE ELLIS.

HENRI SCHNEIDER.

WILLIAM DANIEL ALLEN.

Hon. ABRAM S. HEWITT.

LORD ARMSTRONG, C.B.

ARTHUR COOPER.

JOHN FRITZ.

JOHN GJERS.

HENRY MARION HOWE.

HERMANN WEDDING.

RICHARD PRICE-WILLIAMS.

HENRI DE WENDEL.

JOHN EDWARD STEAD.

FRIEDRICH ALFRED KRUPP.

JOHN OLIVER ARNOLD.

FLORIS OSMOND.

JOHAN AUGUST BRINELL.

In this room also stands a handsome marble pedestal, surmounted by a marble bust of F. Krupp (hon. member of the Institute), bequeathed by Mr. Alfred Longsdon, and a bust of the late Sidney Gilchrist Thomas. Over the mantelpiece is a small bust in cast iron of Professor A. Ledebur (hon. member of the Institute).

The three adjoining rooms on this side are devoted to the library of the Institute. In the last of the three provision is made for special research for the purpose of enabling members desirous of consulting works of reference, or the files of mining and metallurgical periodicals, to do so in quietness and privacy. In this room a card catalogue to the library is available, and the current files of some hundred and fifty technical journals are placed in boxes easy of access.

The last room of this suite (the first on the right, on entering) is the general office for inquiries, &c. In the new premises effective ventilating apparatus is provided, and the hall and rooms are lighted by Osram electric lights. There is telephonic communication between the various rooms. In case of fire there is an iron door to shut off the premises from the rest of the building, and fire-extinction apparatus is provided.

It will be seen from the foregoing that the new premises are considerably larger than those just vacated, and it is hoped that not only will the increased facilities thus provided attract the London members of the Institute who may have occasion to avail themselves of them, but that the members resident in the country and abroad may find them increasingly useful when they visit the metropolis, and thus realise the objects which the Council have had in view in planning and carrying out the necessary alterations.

THE MINING AND METALLURGICAL CONGRESS AT ST. ETIENNE.*

ON June 14 to 18, 1908, the Société de l'Industrie Minérale, the most important mining and metallurgical society in France, celebrated the jubilee of its foundation by a Congress held at St. Etienne. Founded at St. Etienne by the celebrated metallurgist, Gruner, on April 29, 1855, to further the progress of mining and metallurgy, it was but natural that this Society, which now numbers 1400 members, holding sectional meetings in the various mining districts, should select the coalfield of the Loire for the celebration. The Congress, which should properly have been held at an earlier date, was deferred with a view to the simultaneous inauguration of the Society's new quarters in the Engineering Building at St. Etienne. This magnificent building has been erected by the Amicable Society of Old Students of the St. Etienne School of Mines. In it accommodation is provided for the club-rooms of that Society and also for the offices of the Société de l'Industrie Minérale, of the Comité des Houillères de la Loire, and of the Comité des Forges de la Loire.

The Congress, which was attended by 436 members of the Society, was a brilliant success. The attractive programme was briefly as follows: Meetings were held under the presidency of Mr. L. Tauzin on the evenings of June 14, 15, and 16, when papers were read by Professor J. Siegler on the mining industry of the Loire basin, by Professor A. Vicaire on the metallurgical industry of the Loire basin, by Mr. J. Bureau on the working of deposits subject to outbursts of carbonic acid gas, by Mr. J. B. Marsaut on the safety-lamp, by Mr. Francis Laur on economic and industrial monopolies, by Mr. H. Fayol on the jubilee of the Commentry-Fourchambault Company, by Mr. P. H. de Rennéville on the flushing system of stowing mine workings, and by Mr. L. Lemièrre on theories of the formation of coal.

Excursions took place daily, the members being divided into a mining and a metallurgical group. The former visited on June 15 the Roche-la-Molière collieries and the Firminy mines, on June 16 the Montmartre pit of the Loire Mining Company, the Beraudière mines and the Montrambert mines, on June 17 the St. Etienne collieries and the mines of the Loire, and on June 18 the Péronnière mine. The metallurgical group visited on June 15 the Unieux steelworks and the Firminy steelworks, on June 16 the St. Etienne steelworks and the engineering works of Crozet-Fourneyron, Trablaine, and Palle-Bertrand, on June 17 the engineering works of Lefaive & Co.,

* Report presented to the Council of the Iron and Steel Institute by Bennett H. Brough, Secretary.

the Montaud electrical central station, and the French Manufacture of Arms and Cycles, and on June 18 the steelworks at Saint Chamond, and the works of Marrel Brothers and of l'Horme. Each day the members were hospitably entertained at luncheon by the various companies. After the Congress excursions were organised on June 19 to the Rochetaillée dam, and on June 20 to Mount Pilat and to Le Puy-en-Velay, the centre for easy excursions in the beautiful region of the Velay and the Auvergne. The official banquet was held on June 17, and a ball was given on June 18 by the Amicable Society of Old Students of the St. Etienne School of Mines.

From a mining point of view the St. Etienne district is one of surpassing interest. Geologically the coalfield is of Stephanian age. The base of the St. Etienne sequence is a breccia over 500 feet in thickness, which is conformably overlain by a conglomerate varying from 600 to 2500 feet thick. This is succeeded by the productive coal measures of St. Etienne, consisting of a lower group (St. Chamond), 2800 feet thick with twelve seams of coal, a middle group (Bérard) over 1000 feet thick with nine seams, and an upper group (Aveize) from 600 to 700 feet thick with twelve seams. The St. Etienne coalfield is prolonged beneath the Secondary and Tertiary formations towards the Jura.

The mining of coal in the Loire basin can be traced to the earliest times, as even before the twelfth century coal was quarried for use as fuel. It was, however, not until the fourteenth century that the industry attained importance. At that period relations were established between St. Etienne and Lyons, St. Etienne receiving crude iron from Burgundy and Franche-Comté, and giving in exchange coal and manufactured iron. Transport was effected on mules' backs. In the eighteenth century all the hardware received at the Mediterranean ports came from St. Etienne. The collieries shared the general prosperity, and in 1786 the mines of the Forez and Rive de Gier yielded 177,000 tons of coal, a tonnage representing about half the total output of France. The railway from St. Etienne to Lyons was opened in 1830, and the development of the heavy iron and steel industries immediately followed. As the demand for coal increased, mining appliances were rapidly improved. The first vertical shafts were sunk in 1720. They were of small diameter, and their depths did not exceed 20 to 30 yards. Blasting was first adopted in the Loire in 1799 in completing the sinking of a pit at Rive de Gier. In 1810 the first winding-engine was installed. The visits paid to the various collieries enabled visitors to form an idea of the admirable manner in which mining operations are now carried on in the Loire basin. Special mention may be made of the collieries of Roche-la-Molière and Firminy, which are worked by a company formed on June 10, 1820. The concession covers an area of 5856 hectares. There are nine shafts, the deepest being 359 metres. The total output in 1907 was 844,468 tons. The plant for the mechanical preparation of the coal comprises at Roche-la-Molière a Coppée washer treating 80 tons an hour, with 72 coke ovens of the old Belgian type, at the Malafolie

a Humboldt washer treating 30 tons an hour and two agglomerating presses, one of the Couffinhal type producing 5 tons of briquettes an hour, and the other of the Veillon type producing 7 tons. In 1907 there was washed 330,575 tons of coal; and 17,780 tons of briquettes, and 26,983 tons of coke were produced.

From a metallurgical point of view the Loire basin is a region of great historical interest. Although iron was made in the St. Etienne district before the fifteenth century, the industry really dates from 1815. At the instance of Chaptal, minister of the First Empire, an Englishman named Jackson established at Trablaine, near Chambon, the first steelworks in France. A second steelworks was started by Beaunier at the Bérardière, whilst De Gallois erected near Saint Chamond the first forge of the English type. After that progress was rapid. In 1837 Pétin and Gaudet put up at Rive de Gier one of the first power-hammers in France, forging in 1848 the first iron naval gun, and in 1853 the first armour plates.

The first steelworks visited were those of Unieux, belonging to Jacob Holtzer & Co. The members were received on June 15 by Mr. Marcel Holtzer, member of the Iron and Steel Institute, by Mr. H. A. Brustlein, by Mr. Paul Duthu, technical manager, by Mr. L. Demozay (author of the valuable paper on the hardening of steel read at the Vienna meeting of the Institute), and other officials of the company, and were shown the various departments of the works and the different stages of the manufacture of armour plates and projectiles. The casting of a 4-ton ingot of crucible steel was seen, as well as the casting of an 8-ton ingot of steel from the electric furnace.

The electric iron-smelting plant at Unieux is driven by a power plant of 750 kilowatts. A Westinghouse alternator is driven by a compound steam-engine of the Dujardin type, with Belleville boilers. The electric furnace used is of the Keller type, with movable vertical electrodes. Each pole consists of two parallel electrodes. The molten steel from the open-hearth furnace is cast into a ladle from which it is emptied into the electric furnace. The molten steel is then brought into the circuit and the operation of deoxidation carried out. The time of the operation depends upon the quality desired for the steel. The plant was first tried on April 22, 1908, and has proved eminently satisfactory for castings of 10 tons in weight. The works afford employment to 1800 workmen.

In the afternoon of June 15 the Firminy steelworks were visited. The members were received by Mr. Adolphe Hugot and Mr. Marcel Dumuis. The tapping of the blast-furnace, which has a capacity of 210 cubic metres, was first seen, and the various processes of the manufacture of artillery, projectiles, and railway material were then followed. The works afford employment to 2713 workmen, and the equipment includes seven open-hearth furnaces of 4 to 20 tons, eleven puddling furnaces, three furnaces containing 90 crucibles, three cementing furnaces, forty-seven re-heating furnaces, nine rolling-mills, one 2500-ton forging press, and thirty-four steam-hammers of 1 to 40 tons.

On June 16 the visitors were received at the St. Etienne steelworks by Mr. C. Cholat, by Mr. H. Harmet, member of the Iron and Steel Institute, by Mr. F. Beutter, member of the Iron and Steel Institute, and by Mr. Pierre Cholat, who showed the members the manufacture of projectiles, the casting of a 32-ton compressed steel ingot, the cutting of a case-hardened armour plate 240 millimetres thick, the mechanical charging of an open-hearth steel furnace, the rolling of small plates, the forging of a 32-ton compressed steel ingot for armour plate, and the hardening of an armour plate for the *Condorcet*. The Harmet process of fluid compression was followed with great interest. This process, which was described by Mr. Harmet at the Düsseldorf meeting of the Iron and Steel Institute, differs from others in that the pressure is applied from the bottom, the metal being forced up into a conical-shaped mould, thus giving an effect similar to that produced in wire-drawing. Pressure is applied at the correct moment in the most effective manner, and, the solidification taking place under conditions favourable to the formation of the best structure, segregation is reduced to a minimum. Sections of numerous large ingots cut through the longitudinal axis showed that piping had been entirely eliminated. The St. Etienne steelworks afford employment to 1600 workmen, and the equipment includes ten acid or basic open-hearth furnaces, five puddling furnaces, fifty-seven heating furnaces, six rolling-mills, one forging press, and eighteen steam-hammers.

On June 17, in the morning, a visit was paid to the works of Lefaive & Co., at La Chaléassière, St. Etienne. The works are admirably equipped both from the point of view of buildings and machinery, as well as from that of arrangements for the health and comfort of the workmen. Employment is afforded to 900 workmen. The manufactures are of a varied character, and include Collmann steam-engines, Curtis vertical steam-turbines, Buttner multitubular boilers, steelworks machinery, mining machinery, and gas-producers. There is a 600 horse-power central electric-power station. The pattern-making shop covers an area of 600 square metres. The foundry has an area of 6500 square metres, and is equipped for casting machine parts up to 50 tons. The boiler-making shop, in which 400 workmen are employed, covers 7000 square metres, is 12 metres high, and is built entirely of iron.

On June 17 a visit was paid in the afternoon to the central station of the Electric Company of the Loire. The company was formed in 1892 to supply electric energy from an hydraulic power station at Saint Victor sur Loire for the ribbon and velvet factories. The Saint Victor station was installed in 1893 with three hydraulic turbines controlling triphase alternators of 80 volts, with transformers to 5500 volts. These transformers, which are still in operation, are of historical interest, in that they were used at Lauffen, Frankfurt, for the first demonstration of the possibility of long-distance power transmission. At St. Etienne the company erected central stations at Rives in 1896, at Trois Meules in 1899, and lastly, in 1900, the steam-power central station at Montand, where the first unit (a 1500 horse-

power Dujardin engine) was started in 1901; the second unit (a 2800 horse-power Rateau turbo-alternator) in 1906; and a third unit (a Curtis turbo-alternator) is in course of erection. A fourth unit of the same type is to be erected in 1909. In 1900 the company furnished 1500 horse-power, and in 1908, 6000 horse-power. Light and power is supplied to 37 communes of the Loire, and of the Haute-Loire. There are more than 8000 subscribers, who receive current for 14,000 lamps and 6000 horse-power for motors. Current is supplied for the St. Etienne steelworks and for the electric tramways.

At the works of the Manufacture Française d'Armes et Cycles, which were next visited, the members were received by the directors, Mr. Mimard and Mr. Blachon. The works cover an area of 40,000 square metres, and afford employment to 3000 workpeople. The establishment is one of the best installed small-arms factories in the world. The chemical, metallographical, and mechanical testing laboratories, and the pyrometers attached to the various furnaces, afforded evidence of the scientific manner in which the manufacture is controlled.

The visit to the Saint Chamond works, which were described in detail in the *Journal of the Iron and Steel Institute* (vol. lviii. p. 370), proved the most attractive of all the excursions. All the members both of the mining and metallurgical groups participated, and all were struck with the diversity of the work executed, with the vast extent of the establishment, and with the eagerness with which all technical and scientific improvements have been adopted by Mr. A. de Montgolfier (Hon. Member of the Iron and Steel Institute) in the great works that he controls. The company possesses works at Saint Chamond, Assailly, Rive de Gier, Givors (Rhône), Le Boucau (Basses Pyrénées), Homécourt (Meurthe-et-Moselle), Mauberge, and Hautmont (Nord). The equipment comprises nine blast-furnaces, six acid or basic converters, fifteen acid or basic open-hearth furnaces, and four crucible furnaces. The total annual production is 307,000 tons of pig iron and 245,000 tons of steel.

On June 17 the official banquet was held in the new building. Mr. Tauzin, the President of the Society, presided, and he was supported by Mr. Murgue, President of the Amicable Society of Old Students of the St. Etienne School of Mines, by Mr. Delafond, Inspector-general of Mines, and by Messrs. H. Le Chatelier, Reumaux, Marsaut, Couriot, Fayol, Rateau, Pourcel, Harmet, Friedel, and about 400 members of the Society. The visitors were welcomed by Mr. Murgue, who described the steps that had been taken by the old students to erect the engineering building. The President then handed the Gold Medals of the Society to those members who, during the past fifty years, had contributed most to the development of mining and metallurgy. The medals were awarded to Louis Aguillon for his work on mining law, to Henri Le Chatelier (member of the Iron and Steel Institute) for his researches on metallography and explosives, to G. Chesneau for fire-damp detection, to Henri Fayol for his work on combating mine-fires, to A. François for his work in connection with colliery explosions, to J. B. Marsaut for his safety-lamp, to E. Reumaux for his improve-

ments in methods of mining, to A. Pourcel (member of the Iron and Steel Institute) for his improvements in the manufacture of steel, and to A. Rateau for his applications of machinery to mining and metallurgy. Congratulatory addresses were then presented by Mr. Bennett H. Brough on behalf of the Iron and Steel Institute, and by Mr. A. M. Hedley on behalf of the North of England Institute of Mining Engineers. Various toasts followed. Mr. Huart, Prefect of the Loire, proposed the health of the President of the Republic, Mr. Charpentier, member of the Chamber of Deputies, that of the working men of the Loire district, and Mr. Brough that of the Société de l'Industrie Minérale. Regrets having been expressed by Mr. Gruner and others that the rules of the Society precluded the award of medals to Mr. Brustlein and Mr. Harmet, members of the Council, the President stated that the matter would be dealt with at the next general meeting.

The whole programme had been admirably organised, the arrangements for special trains and carriages, under the able direction of Mr. H. Verney, the Treasurer and Registrar of the Society, worked without a hitch, and the Congress proved to be one of the most successful gatherings of the kind on record. Abstracts of the papers read will be given in the Journal of the Institute when they have been published in the official *Bulletin* of the Society.

O B I T U A R Y .

HERMANN WEDDING, Hon. Member of the Iron and Steel Institute, died on May 6, 1908, in Düsseldorf. Born on March 9, 1834, he was the son of J. W. Wedding, director of the government printing-office and eldest son of Johann Friedrich Wedding, the eminent Silesian ironmaster, who in 1794 built the first coke blast-furnace on the continent of Europe. Dr. Wedding was educated at the Berlin Gymnasium, and on leaving the school entered the government mining service, the advice of Dr. C. J. B. Karsten, author of the well-known treatise on the metallurgy of iron, an old friend of the family, having guided him in the choice of a career. On October 7, 1853, he was received as "Beflissener" in the Breslau mining district, and appointed to the Royal Ironworks at Malapane. He subsequently worked practically at the Friedrichs mine near Tarnowitz, the Friedrichshütte and the Rybnik ironworks, the Königshütte and Königsgrube. After two years' experience in Upper Silesia, he proceeded to Berlin for his military service, and began there his university studies. He subsequently studied at Freiberg, and received the degree of Doctor of Philosophy at Berlin on April 7, 1859. He then travelled for some time in Belgium and South Wales. In March 1861 he passed his examination as "Bergreferendar," and received his first government appointment as official at Eiserfeld in the Siegen district. At the International Exhibition in London in 1862, where he acted as Commissioner for the German Customs Union, he made the acquaintance of Dr. Percy, an acquaintance that developed into intimate friendship. The desire he then formed to devote his life to the metallurgy of iron was strengthened by a journey that he made with the head of the Prussian mining department, Krug von Nidda, through England. On December 5, 1863, he was appointed lecturer on metallurgy at the Berlin School of Mines, and he continued until his death to be unremittingly active in educating young metallurgists, and in their subsequent careers many of his pupils took a large part in furthering the remarkable development of the German iron trade.

Wedding's contributions to metallurgical literature are known all over the world. He translated into German Dr. Percy's "Metallurgy of Iron and Steel," a task that occupied twelve years. The second edition was quite a new work. The first part was published in 1892, and the second part of the fourth and last volume has only recently appeared. In 1871 he published his *Grundriss der Eisenhüttenkunde*, of which five editions have been issued. He also wrote a small popular book on the metallurgy of iron for working men (2nd edition, 1908.—i.

1904). Besides these he was the author of *Aufgaben der Gegenwart im Gebiete der Eisenhüttenkunde* (Brunswick, 1888) and *Die Eisenprobierkunde* (Brunswick, 1894). The numerous papers read by him at various Congresses, and those published by him in the Transactions of technical societies and in the technical journals, afford evidence of his remarkable industry and of the eagerness with which he followed the progress of metallurgy.

From 1867 until the close of his life he was a member of the Royal Technical Deputation for Trade and Industry. From 1877 to July 1, 1907, he was a member of the Imperial Patent Office, and devoted a large share of his energy to the work. He was a great traveller and an excellent linguist, and was always anxious to encourage cordial international relations in metallurgy. He was a regular attendant at Congresses and meetings of technical societies, and acted either as Commissioner or as juror at almost all great technical and International Exhibitions (London, Stockholm, Vienna, Philadelphia, Paris, and Chicago).

In recognition of his great services to the metallurgy of iron, Wedding was the recipient of numerous honours. He received the title of Geheimer Bergrat, as well as the decorations of the Order of the Red Eagle, the Order of the Crown, the Bavarian Order of St. Michael, the Order of the Austrian Iron Crown, the Russian St. Stanislas Order, and the Swedish Order of the Pole Star. He was an honorary member of the Society of German Ironmasters, of the American Institute of Mining Engineers, of the United States Association of Charcoal Ironworkers, of the "Hütte," and of the Verein zur Beförderung des Gewerbfleisses. The last-named society also awarded him their gold medal. Of the Iron and Steel Institute he was an honorary member, and in 1896 received the Bessemer gold medal. He contributed six papers to the Institute's Journal. The first, on the working of blast-furnaces with raw coal, was read in 1872, and was followed by papers on the iron industry of Germany (1880), on the Royal Prussian Institutes for testing iron and steel at Berlin (1882), on the properties of malleable iron deduced from its microscopic structure (1885), on the progress of German practice in the metallurgy of iron and steel (1890), and on the roasting of iron ores with a view to their magnetic concentration (1896).

HIS GRACE THE DUKE OF DEVONSHIRE, K.G.—The Iron and Steel Institute has to deplore the decease of its most noble member, the eldest son of the Institute's first President, the eighth Duke of Devonshire, who died at Cannes on March 24, 1908. His death deprived the Empire of one who will ever rank among the greatest and most distinguished of English statesmen.

Spencer Compton Cavendish, eighth Duke of Devonshire, was born on July 23, 1833. To write the history of the distinguished house to which he belonged would be to write the history of England from the time when Sir John Cavendish was Chief-Justice of the Court of King's Bench in 1366. For many generations the Cavendishes have

been distinguished alike in politics, in diplomacy, in pure and applied science, and for their social virtues and accomplishments.

The main outlines of the Duke's public career will be known to most. The eldest son of the seventh Duke, he began his political apprenticeship at the age of twenty-three by taking part in Earl Granville's special mission to Russia at the Coronation of Alexander II. In March 1857 he was first returned to the House of Commons, and thence until 1892, when he succeeded to the Dukedom, he sat continuously in that Chamber, for though at the General Election of 1868 he lost his seat for North Lancashire, he was immediately returned for another constituency. His official Parliamentary life began in 1863, when he was appointed a Lord of the Admiralty. Less than a month afterwards he was made Under-Secretary for War, and on the reconstruction of Lord John Russell's second Administration, the Marquis of Hartington, as he then was, became Secretary for War, at the age of thirty-three. Subsequently he was Postmaster-General in Mr. Gladstone's Cabinet of 1868, and then Chief Secretary for Ireland. When, in 1875, Mr. Gladstone, then in Opposition, thought of retiring, the Marquis of Hartington was appointed his successor as leader of the party in the House of Commons.

On the return of the Liberals to power the Marquis of Hartington was sent for by the Queen to form an Administration, but he declined, and served under Mr. Gladstone as Secretary for India and afterwards as Secretary for War. At the time of the great Home Rule split in 1886 it was Lord Hartington who became the leader of the Dissident Liberals and moved the rejection of the Bill. On Mr. Gladstone's resignation, Lord Salisbury proposed that the Marquis of Hartington should assume the Premiership; but, for the second time in six years, he declined that honour. Many subsequent efforts were made to induce him to join the Government, but he preferred to remain independent. In the House of Lords he again led the attack on the second Home Rule Bill. On the Conservatives coming back to power in 1895 the Duke of Devonshire definitely severed himself from the Liberals and accepted office as Lord President of the Council, a post which he occupied from 1895 to 1903, when the Tariff Reform movement caused him to dissociate himself from his colleagues.

On the day of his death, in both Houses of Parliament striking tribute was paid to his memory. In the Upper Chamber, after the Marquis of Ripon and the Marquis of Lansdowne had spoken from the two Front Benches, Lord Rosebery, at the close of an eloquent speech, moved the adjournment of the House as a mark of respect to the late Duke. In the course of his speech Lord Rosebery said: "It is men of that kind that form the glory of our country. We have many statesmen who occupy high office, and many other countries have these, but few countries have men of high capacity with every temptation to sloth who devote themselves to the service of their country without the slightest ultimate personal object or ambition. That was the Duke of Devonshire's proud position, and it was for that reason, I think, the country always sought his judgment and opinion on current

events, and why he will leave after him a memory which even men of more conspicuous genius have failed to bequeath. He bore a proud name; there is no prouder name in all this House than the name of the Duke of Devonshire. His forefathers have rendered at various times inestimable service to the State, but I greatly question in all that long, illustrious line if any of the Dukes of Devonshire or the Cavendishes will have left a name more trusted and beloved, more justly trusted and more justly beloved, than the Duke whom we mourn to-day."

Politics represented only one side of the Duke's career. He was a great social figure—friend of kings and princes, a pillar of the turf, and, as owner of 186,000 acres, a territorial magnate of almost unequalled influence. He was Chancellor of the University of Cambridge (1892), Lord-Lieutenant of Derbyshire (1892), His Majesty's Lieutenant of County Waterford (1892), Lord Rector of Glasgow University (1877), Chancellor of the University of Manchester, and Provincial Grand-Master of Derbyshire Freemasons since 1858. He was Chairman of the Barrow Hæmatite Steel Company, Limited, and of the Furness Railway Company.

In 1888 the Duke of Devonshire joined the Iron and Steel Institute, of which his father, the seventh Duke, was the first President; his brothers, Lord Frederick Cavendish and Lord Edward Cavendish, were members of Council, and his heir, the Right Hon. Victor Cavendish, M.P., is a Vice-President. On several occasions the Duke attended the meetings and banquets of the Institute. At the annual dinner in 1895 he made an eloquent speech, in which he expressed his belief that to the influence of the Iron and Steel Institute was due in no small degree that series of scientific and mechanical inventions by which the cost of production of iron and steel had been during the last quarter of a century so enormously diminished, and by which alone it had been possible for those industries to compete with the depressing times which had had to be encountered. At the Manchester meeting in 1899, and again at the Sheffield meeting in 1905, the Duke was a member of the Reception Committee, and entertained the members at luncheon at Chatsworth. At the Barrow meeting in 1903 he was chairman of the Reception Committee, and at the joint meeting with the American Institute of Mining Engineers in London in 1906 he again showed his interest in the work of the Institute by joining the Reception Committee.

REYNOLD HENRY NEWTON ALLEYNE died at Falmouth on April 6, 1908, in his fifty-sixth year. He was the sole surviving son of Sir John G. N. Alleyne, Bart., senior Vice-President of the Institute, and he inherited much of his father's mechanical genius, and after leaving Winchester adopted engineering as his profession, but owing to indifferent health he was not able to give full scope to his great natural abilities. He was at first apprenticed to Messrs. Napier & Sons, shipbuilders and engineers, Glasgow; after that he was for some years engaged in a mechanical tool business in Leeds, and latterly

had been managing director of the Norfolk Estuary Company, which was formed for the purpose of resisting encroachments of the sea on the Norfolk coast. He was elected a member of the Iron and Steel Institute in 1875.

ALFRED BALDWIN, M.P., chairman of the Great Western Railway, died suddenly on February 14, 1908, at Kensington Palace Mansions. The youngest son of the late G. P. Baldwin, he was born in 1841. He was educated privately, and early commenced his business career, which was prosperous almost from the very first. Besides being chairman of the Great Western Railway—a post he succeeded to on the retirement of Earl Cawdor in 1905—he was chairman of Messrs. Baldwins, Limited, one of the most powerful amalgamations in the country, for it combines the business of E. P. and W. Baldwin, Ltd., Wright, Butler, & Co., Ltd., of Birmingham, Alfred Baldwin & Co., Ltd. (paper mills), the Bryn Navigation Colliery Company, Ltd., and the Blackwall Galvanised Iron Company, Ltd. He was also chairman of the Metropolitan Bank (of England and Wales) and of the Aldridge Colliery Company, Ltd., in addition to being on the board of Messrs. Allen, Everitt & Sons, Ltd., and deputy-chairman of the Central Insurance Company. During his career he had also been a director of the following companies: Fishguard and Rosslare Railways and Harbours Company (chairman), Golden River Quesnelle, Limited, Anglo-American Tin Stamping Company (chairman), Archibald Kenrick & Sons, and Bentong Straits Tin Company. In addition to the strenuous labours these positions must have entailed, he also discharged the duties of magistrate of Staffordshire, and was a deputy-lieutenant for Worcestershire, for which county he acted as high sheriff in 1894. He had represented the Bewdley Division of Worcestershire in the Conservative interest since 1892, and was a consistent Tariff Reformer. He was a member of the Institution of Mechanical Engineers. He was an original member of the Iron and Steel Institute.

CHARLES JOHN COPELAND died at Liverpool on January 8, 1908. He served his apprenticeship under the late Mr. Bouch, at the Sheldon Works of the North-Eastern Railway, after which he was for some time with the firms of Geo. Stevenson & Co. and Bairds of Stockton. He then went to sea for some years as a marine engineer, after which he became manager of Messrs. Westray & Co. of Ulverston, ultimately becoming a partner, when the firm opened a works at Barrow under the title of Westray, Copeland & Co., shipbuilders and engineers, and for the past eighteen years, up to the time of his death, he was practising in Liverpool as a consulting engineer and naval architect. He was elected a member of the Iron and Steel Institute in 1873.

HENRY DAVIES died at his residence in Preston on May 9, 1908. He was a director of the Ebbw Vale Company, the Tawd Vale

Colliery, and the Littlewood Brick and Tile Company. He was a Justice of the Peace, and served as Mayor of Preston in 1896-1897. He was elected a member of the Iron and Steel Institute in 1896.

JOHN DICKINSON of Sunderland died at Harrogate, on July 3, 1908, at the age of eighty-three. He was a native of Hebburn, and moved to Sunderland when he was about twenty-two years of age to work at his trade as a blacksmith. In 1852 he established a business of his own, but not until 1892 was that business converted into the limited liability form, under the style of John Dickinson & Sons, Limited. He became chairman of the company, with his three sons on the board. In 1906 the output of the firm, employing about 2000 men, included 33 sets of marine engines and 3000 tons of boilers. Mr. Dickinson was a member of the River Wear Commission, an office which he held for about eighteen years. He was a Justice of the Peace for the county of Durham, a life governor of the Sunderland Infirmary, and took a deep interest in local affairs. He was elected a member of the Iron and Steel Institute in 1884.

WALTER FEARNEHOUGH died at his residence, 3 Claremont Place, Sheffield, on December 31, 1907, at the age of fifty-nine. He was head of one of the largest machine-knife manufacturing businesses in Sheffield, and was well known in the lighter steel industry of that city. He was elected a member of the Iron and Steel Institute in 1886, and was a member of the Reception Committee at Sheffield in 1905.

WILLIAM THOMAS FLATHER died at Sidmouth, South Devon, on May 30, 1908. He was managing director of the Standard Steelworks at Sheffield. He was elected a member of the Iron and Steel Institute in 1881, and was a member of the Executive Reception Committee for the Sheffield meeting in 1905.

GEORGE GARRETT, one of the leading ironmasters in Scotland, died at Coatbridge on May 11, 1908, at the age of sixty-two. He was a native of Walbs, and brother of the late William Garrett, the well-known authority on wire-rod rolling. In early life he was engaged by the Russian Government to erect ironworks near St. Petersburg. When he went to Coatbridge he, with his partner (Mr. Davie), erected the Waverley Iron and Steel Works. He was elected a member of the Iron and Steel Institute in 1884, and was an active member of the Reception Committee for the Glasgow meeting in 1901.

GEORGE HARRISON died on December 21, 1907, as the result of injuries received in an accident at the Royal Arsenal, Woolwich. He was born in Edinburgh in May 1880, and educated at Viewpark and Merchiston Castle schools. After serving an apprenticeship to the firm of James Milne & Sons, Ltd., he entered Peterhouse College, Cambridge, and attended the Engineering Laboratory. He graduated

with Second Class Honours in the Mechanical Science Tripos, and in February 1905 received an appointment in the Royal Carriage Department of Woolwich Arsenal as shop manager, a position which he held at the time of his death. He was elected a member of the Iron and Steel Institute in 1906.

JOHN HART died on December 3, 1907, at the age of sixty-five. He was in business at Middlesbrough for over thirty years as consulting and inspecting engineer, and as an expert on the manufacture of rails and constructional steelwork. He acted as arbitrator in many cases with regard to rails, and in this capacity went to Japan some years ago, and afterwards to Egypt. He was elected a member of the Iron and Steel Institute in 1877.

PETRONIUS HODGES died at Sheffield in January 1908. He served his apprenticeship in the Locomotive Department of the Great Northern Railway Co. at Peterborough and Doncaster, and in 1866 he joined the firm of Cammell, Laird & Co., and was appointed manager of their Penistone works. He subsequently became one of the chief officials of the firm at the Sheffield works, retiring in 1904. He was elected a member of the Iron and Steel Institute in 1884, and was a member of the Reception Committee at Sheffield in 1905.

TOM COBB KING, who died at New York on February 27, 1908, was born at Marion, Alabama, on June 10, 1861. He graduated from Howard College at that place, and later from the Massachusetts Institute of Technology at Boston. He held office as superintendent, manager, or in similar capacity, in charge of the Briar Hill Coal and Iron Company's works at Youngstown, Ohio; the Clifton Iron and Steel Company's works at Ironaton, Alabama; the Crown Point works of the American Steel and Iron Company. He was one of the few men who made ferro-manganese in America. He built works in various places, including a large blast-furnace plant at Sharon, Pennsylvania, and a plant at Marietta, Pennsylvania. For some time he had been residing in New York city engaged with various professional interests, among others, processes invented by him for nodulising and desulphurising all high-grade ores, and a new process for refining nickel. He was a member of the American Institute of Mining Engineers. He was elected a member of the Iron and Steel Institute in 1904.

JOHN FINLAY MACLAREN died on January 9, 1908, at his residence in Glasgow, in his fortieth year. He was an ironfounder, and part proprietor of the Eglinton Foundry, Port Eglinton, Glasgow. He was elected a member of the Iron and Steel Institute in 1890.

HENDRIK POST VAN DER BURG died at Rotterdam on December 31, 1907. He was for many years connected with the iron trade and

engineering industries of Holland, and was managing director of the Nederlandsche-Indische Industrie, whose works were situated at Soerabaia. The firm also acted as importers of machinery and of materials connected with the manufacture of iron and steel. Mr. Post van der Burg was elected a member of the Iron and Steel Institute in 1905, and in the autumn of 1907 took part in the Vienna meeting.

WILLIAM RADCLIFFE died at his residence, Clarke Grove Road, Sheffield, on March 26, 1908, at the age of sixty-four years. Born at Oldham in 1844, he was educated at Owens College, Manchester; was one of the founders of the Phoenix Bessemer Steel Company, Ltd., and of the firm of Hampton, Radcliffe & Co. in July 1872, which was afterwards acquired by Steel, Peach & Tozer, Ltd. He erected a lot of bridgework for the old Manchester Sheffield, and Lincolnshire Railway Co., now the Great Central Railway. He was senior partner of Radcliffe, Son & Crockford, London, and a director of Gregory, Reddish & Co., Ltd., Sheffield. He was a member of the Institution of Mechanical Engineers. He was elected a member of the Iron and Steel Institute in 1890, and was a member of the Sheffield Reception Committee in 1905.

Sir DAVID RICHMOND, ex-Lord Provost of the city of Glasgow, and chairman of the Clyde Trust, died on January 15, in his sixty-fifth year, at his house, Broom Park, Pollokshields. He was noted less perhaps as the founder of a highly successful tube-making business than as an indefatigable worker not only in connection with the civic affairs of Glasgow, but in all matters concerned with the development of its industries, and especially of the river Clyde, its docks, shipping, and shipbuilding. He was born in Deanston, Perthshire, in 1843. His parents, in the year following, removed to Glasgow, and he received most of his education in the High School of the city. Ill-health overtaking him just as he had completed his education, he went to Australia and New Zealand to regain his strength, returning with enlarged experience in 1866. Two years later he began business on his own account as a manufacturer of iron tubes at the original City Tube Works, removing later to the works of the same name in Hutchesontown. Under his guidance the business became so successful that the Hutchesontown works soon proved insufficiently large to meet the trade, and accordingly the North British Tube Works, Govan, were acquired, and have had to be considerably extended since. From 1879 till his retirement in 1899 he served in the Town Council of Glasgow, in that time filling all the chief offices, including the Lord Provostship, to which position he was elected in 1896. It was largely owing to his exertions that the Prince's Dock was constructed. In 1899, the third year of his occupancy of the Lord Provostship, he received his knighthood. Although, in virtue of his provostship, he had previously occupied the position, the latest public appointment conferred on him

was that of chairman of the Clyde Trust in November 1907. He was elected a member of the Iron and Steel Institute in 1895, and was a member of the Reception Committee for the Glasgow meeting in 1901.

RICHARD SMITH-CASSON died at his residence, Roseville, Paignton, South Devon, on December 12, 1907, at the age of sixty-eight. For many years he was associated with the Round Oak Ironworks at Brierley Hill. He was elected a member of the Iron and Steel Institute in 1877, and resigned in 1900. He contributed to the Journal a paper in 1884 on gas puddling and heating furnaces, with special reference to the Casson-Bicheroux system, and in 1895 one on small cast steel ingots.

CARL NICOLAI ANDREAS SOLBERG died in Norway on March 22, 1908. He was born in Drammen, Norway, and educated at Drammen Grammar School. He entered the University of Christiania in 1889. Afterwards he went to Caius College, Cambridge, where he studied science, especially electricity, and graduated as Bachelor of Arts in 1893. He then returned home and became interested in and afterwards managing director of the electrical concern Norsk Elektrisk Aktiebolag from 1898 to 1905. After having effected in this year a combine of this firm with the Norway branch of the firm of Brown Boveri & Co., of Baden, Switzerland, he went for a time to Baden, but having from his stay in Cambridge always had a great liking for England, he soon afterwards accepted an offer of the management of the new branch of the Electrical Company Ltd. at Newcastle. In the autumn of 1907 he was taken ill, and went by his physician's advice to Egypt, but becoming worse he returned to Norway, where he died. He was elected a member of the Iron and Steel Institute in 1907.

HENRY CLIFTON SORBY, the scientist of world-wide reputation, died at his residence in Sheffield on March 9, 1908, in his eighty-second year. Coming of a family which had been associated with Sheffield since the time of Henry VIII., he was born on May 10, 1826, his father, the late Henry Sorby, of Woodbourne, Attercliffe, being a member of the well-known firm of J. & H. Sorby, of Spital Hill, edge tool manufacturers. He was educated at the Sheffield Collegiate School and by private tutors, and he early evinced an interest in chemistry and other sciences. His name began to be known in connection with scientific work before he had reached the age of twenty-one. He published his first paper, the subject being agricultural chemistry, in 1847, and since that time he has written no fewer than two hundred and forty publications on various topics connected with his investigations. As an original investigator his work has been keenly appreciated by various learned societies. In 1853 he was elected a Fellow of the Geological Society of London, and was in 1869 presented with the Woollaston Gold Medal for his application of the

microscope to the study of rocks. He was President of the Society from 1878 to 1880. In 1857 he became a Fellow of the Royal Society, and served on the Council in 1876 and 1877, receiving in 1874 one of the two gold medals given by the late Queen. He was one of the eighteen foreign members of the Academy of the Sciences in Rome, the oldest scientific society in the world. In 1872 he was presented with the Medal of the Dutch Society of Science, which is awarded once in twenty years to the one who has done most to advance geology and mineralogy in that period. He was President of the Royal Microscopical Society in 1875, and was re-elected in 1876 and 1877. In 1876 he was appointed the first President of the Mineralogical Society of Great Britain and Ireland. The University of Cambridge conferred the honorary degree of LL.D. upon him in 1879. For a number of years he was one of the secretaries of the Geological Section of the British Association, and was President of that section at the Swansea meeting in 1880. When the British Association visited Sheffield in 1879, he was one of the local secretaries, and was subsequently elected to the Council. He was also a member of the Imperial Mineralogical Society of St. Petersburg, the Dutch Society of Science, and Mineralogical Society of Brussels, a corresponding member of the Lyceum of Natural History, and of the Academy of Natural Science in New York, the Academy of Natural Science in Philadelphia, and of many British societies. In Sheffield he was President of the Literary and Philosophical Society in 1852. He was re-elected to that office several times, and on the occasion of his completing his fifty years' connection with the society he was again re-elected to the chair and presented with his portrait, alike to celebrate the jubilee, and, in the words of the inscription, "to commemorate his world-wide scientific reputation."

Dr. Sorby rendered conspicuous service to his native city, notably in the establishment of the Technical School, which is now a Department of Sheffield University. He worked hard to secure the success of that institution, and, on its being successfully established, was appointed its first chairman. He was also one of the most generous contributors to its funds. He was President of Firth College from 1882 to 1897. In the latter year the College became the University College of Sheffield, and he resigned in order that the Duke of Norfolk might be elected to the presidency. He remained, however, on the governing body of the College, and on the charter for a university being granted, he was appointed to the Council, was a member of the Committee for the Department of Applied Science, and held both these positions up to his death.

In 1849 he founded the science of petrography, having prepared in that year the first rock section ever examined by transmitted light. In 1856 he enunciated his theory, now generally accepted, that the Cleveland ironstone hills had been originally calcium carbonate, which had been gradually replaced by carbonate of iron derived from associated strata. The study of rocks led him to that of meteorites, and enabled him to show that they have interesting points of relation to volcanic

rocks and consolidated ashes. In order to throw light on meteoric iron he was led to prepare slightly etched sections of artificial irons and steels, and it was soon found that by studying these by means of illuminators contrived by himself and others, not before applied to such a purpose, most important information could be gained, so as to put our knowledge of iron and steel on an entirely new footing. He read papers on the subject, and exhibited microscopic photographs before the British Association at Bath in 1864, and before the Sheffield Literary and Philosophical Society, but though the specimens were often publicly exhibited and described, the subject attracted little or no notice for more than twenty years, when, at the request of Dr. Percy in 1886, he contributed to the Iron and Steel Institute a paper on the application of very high powers to the study of the microscopical structure of steel. This was followed in 1887 by a paper giving the complete results of his twenty years' study of the microscopical investigation of iron and steel. Referring to this paper Dr. Percy, the President, said that he had a strong impression that, from a scientific point of view, great results were likely to flow from this line of investigation, which might possibly admit of valuable application in the manufacture and working of iron and steel. Dr. Percy's prediction was borne out by results, and in the words of the obituary notice in *Nature* (vol. lxxvii. p. 466), "Dr. Sorby placed in the hands of metallurgists for all time a new and most valuable method of scientific investigation." Dr. Sorby was elected a member of the Iron and Steel Institute in 1886, and the last time he appeared at its meetings was in 1906 at Sheffield, when, as a member of the Reception Committee, he was wheeled into the Firth Hall of the new University buildings wearing his academic robes, and expressed his pleasure that so much interest was now taken in the study of the microscopic structure of steel compared with the little interest taken twenty years previously, when he contributed his papers on the subject to the Institute.

HENRY FREDERICK SWAN, C.B., the High Sheriff for Northumberland, died on March 25, 1908, at his home, Prudhoe Hall, Prudhoe. He was born on September 10, 1842, at West Farm, Walker-on-Tyne. He was educated privately, and when sixteen years of age commenced his apprenticeship with the late firm of C. Mitchell & Co., shipbuilders. In 1862 he went to Russia to superintend the construction of vessels for the Russian Navy for Messrs. Mitchell & Co., who had received the order. On his return to this country he took charge of the Walker shipyard, which he had seen grow from a very small yard to one of the best equipped ship-building yards in the country. In 1882 Messrs. C. Mitchell & Co. amalgamated with Sir W. G. Armstrong & Co. of Elswick under the style of Sir W. G. Armstrong, Mitchell & Co., Limited, and the name of the firm was again changed in 1897, when it amalgamated with that of Sir Joseph Whitworth & Co. of Manchester. Since that time the firm has been known as Sir W. G. Armstrong, Whitworth & Co., Limited. Mr. Swan remained one of the managing directors, devot-

ing most of his time to the development of the shipbuilding business at the Walker yard. He was also a director of the Wallsend Slipway and Engineering Company, Limited; the Weardale Steel, Coal, and Coke Company, Limited; and the Cargo Fleet Iron Company, Limited.

In 1884 he made a special study of the question of the carriage of petroleum in bulk, and at that time designed and built the s.s. *Glückauf*, which was the first vessel specially built to cross the Atlantic with a cargo of petroleum. He also paid great attention to the construction of ice breakers, and many of the largest and best vessels of this type are the outcome of his experience and ingenuity. He took a keen interest in public affairs, and was especially interested in the volunteer movement, with which he was actively connected for forty-two years, and in recognition of his services he was created a Companion of the Bath on his retirement in 1902, and enrolled as honorary colonel of his regiment. He was a member of the Institution of Civil Engineers, member of the Council of the Institution of Naval Architects, past-president of the North-East Coast Institution of Engineers and Shipbuilders, and a member of the North of England Institute of Mining and Mechanical Engineers. He was elected a member of the Iron and Steel Institute in 1874.

ROBERT THOMPSON died on January 1, 1908, at the age of fifty-seven. He was the eldest son of the late Joseph L. Thompson, and was educated at Gainford School. He was the principal partner and chairman of directors of the shipbuilding firm of Joseph L. Thompson & Sons, Limited, of Sunderland. He had very varied experience, having been actively engaged in the shipbuilding industry since the year 1865. His firm have, on a great many occasions, held the record of having launched in one year the largest amount of tonnage on the Wear. Besides directing the affairs of the shipbuilding and repairing business, Mr. Thompson was an active partner in the Sunderland Forge and Engineering Company, Limited; he was one of the founders of the Wearmouth Laundry Company, Limited; chairman of directors of the Skinningrove Iron Company, Limited; and was connected with various other business companies. He was a county Justice of the Peace, a Freeman of the Worshipful Company of Shipwrights, a Governor and Member of Council of the Durham College of Science, Newcastle-on-Tyne, and was one of the founders of the North-East Coast Institution of Engineers and Shipbuilders, of which, during the two sessions 1891-92 and 1892-93, he occupied the presidential chair. He was also a member of the Council of the Institution of Naval Architects, and for a number of years was one of the North-East Coast representatives on the Committee of Lloyd's Registry of British and Foreign Shipping, and acted as a member of the Technical Sub-Committee. He was also a member of the River Wear Commission and of the Borough Council. He was elected a member of the Iron and Steel Institute in 1886.

The obituary of the half year also includes the names of Sir HOWARD VINCENT, K.C.M.G., C.B., who was an active member of the Sheffield Reception Committee in 1906, and frequently attended meetings of the Institute; of ALFRED HABERS, the eminent professor of mining at Liège, who took an active part in the reception of the Institute at Liège in 1873 and at Brussels in 1894; and of F. H. WEBB, who during the twenty years he was secretary of the Institution of Electrical Engineers had frequent relations with the Iron and Steel Institute. The death is also announced of BENJAMIN HOWARD THWAITE, who, although not a member, contributed to the proceedings papers on the metallurgic department of the Sheffield Technical School (1891), on fuel and its efficiency (1892), on the profitable utilisation of power from blast-furnace gases (1901), on the effect of flue dust upon the thermal efficiency of hot-blast stoves (1903), on the use of steel in American lofty building construction (1904), on accidents due to the asphyxiation of blast-furnace workmen (1905), and on the economic distribution of electric power from blast-furnaces (1907). He was one of the pioneers in the utilisation of blast-furnace waste gases as motive power, his patent (No. 8670) having been taken out in May 1894. A 30-horse-power gas-engine designed in accordance with this patent was started in Scotland by Mr. James Riley in February 1895.

ADDITIONS TO THE LIBRARY

DURING THE FIRST HALF OF 1908.

Title.	By whom Presented.
Transvaal Mines Department. Report of the Geological Survey for 1906. 4to, pp. 140. Pretoria. 1907.	The Director of the Geological Survey.
Queensland Department of Mines. Publications of the Queensland Geological Survey. Nos. 207, 208, 209, 210, 211, 212, with map. 8vo. Brisbane. 1906-7.	The Queensland Geological Survey.
Mysore Geological Department. Report of the Chief Inspector of Mines for the year 1904-1905, with Statistics for the Calendar Year 1904. Fcap. folio, pp. 20, with 13 tables. Madras. 1907.	Mysore Geological Department.
"The Metallurgy of Steel." By F. W. Harbord. Third edition, revised. 8vo, pp. 770, with 37 folding plates, over 282 illustrations in the text, and nearly 100 photomicrographs of steel sections. London. 1907.	W. H. Bleckly
"Map and Plotted Vertical Sections of Strata of the Northumberland and Durham Coalfield." By John Kirsopp, Jun., Newcastle-on-Tyne.	R. E. Commans.
"Gemeinfassliche Darstellung des Eisenhüttenwesens." 6 Auflage. Large 8vo, pp. 254. Düsseldorf. 1907.	Verein deutscher Eisenhüttenleute.
North of England Institute of Mining and Mechanical Engineers. Subject-matter Index of Mining, Mechanical, and Metallurgical Literature for the year 1902. Edited by M. Walton Brown. 8vo, pp. 180. Newcastle-on-Tyne. 1907.	The Society.
"The Ironmonger" Metal Market Year Book, 1908. 8vo, pp. 73. London.	A. C. Meyjes.
Souvenir Pamphlet in connection with the Decorations bestowed by the French Republic upon Charles Kirchhoff, T. C. Martin, and P. C. Grant. 8vo.	The Director of the American Museum of Safety Devices and Industrial Hygiene.
Memorial of the Celebration of the Carnegie Institute at Pittsburgh, 1907. 4to, pp. 465.	The Trustees.
"Introduction to Metallography." By Paul Goerens. Translated by F. Ibbotson. 8vo, pp. 214. London. 1908.	Longmans, Green & Co.
"The Blast-furnace and the Manufacture of Pig Iron." By Robert Forsyth. Demy 8vo, pp. 368. New York. 1908.	David Williams Co.
"British Engineering Standards Coded Lists." (Structural Steel for Shipbuilding and Marine Boilers, Steel Castings and Forgings for Marine Purposes.) 4to, pp. 409. London. 1908.	The Committee.
"Inventions and Designs in the Year 1907." Issued by the Government of India (Department of Commerce and Industry). Demy 8vo, pp. 202. Calcutta. 1908.	H. G. Graves.
"The Electric Furnace in Iron and Steel Production." By J. B. C. Kershaw. 8vo, pp. 66. London. 1907.	Bennett H. Brough.
"Iron and Steel." By J. H. Stansbie. 8vo, pp. 375. London. 1907.	Bennett H. Brough.
"Industrie des Métaux Secondaires et des terres rares." By P. Nicolardot. Small 8vo, pp. 345. Paris. 1908.	The Author.
"McNeill's Code" (1908 Edition). By Bedford McNeill. 8vo, pp. 167. London. 1908.	The Author.

Title.	By whom Presented.
"Western Australia." Bulletins Nos. 27, 28, 29, and 30, with maps of the Geological Survey. 8vo. Perth. 1907.	The Agent-General for Western Australia.
"Nomenclatura Geologica" (Gres e Arenite, Schisto e Folhelho). By Arrojado R. Lisboa. (Extract from the <i>Annaes da Escola de Minas de Ouro Preto</i> , No. 8, 1906.)	The Author.
"Bibliographia mineral e geologica do Brazil, 1903-1906." By Arrojado R. Lisboa. (Extract from the <i>Annaes da Escola de Minas de Ouro Preto</i> , Nos. 8 and 9, 1906.)	The Author.
Department of Mines, Victoria. Memoir No. 6 of the Geological Survey. Melbourne. 1908.	The Secretary for Mines and Water Supply.
American Iron and Steel Association. "The Directory of the Iron and Steel Works of the United States." Seventeenth Edition. 8vo, pp. 500. Philadelphia. 1908.	J. M. Swank.
Statistisches Jahrbuch des k.k. Ackerbau-Ministeriums für das Jahr 1906. 8vo, pp. 205. Vienna. 1906.	Bennett H. Brough.
"Text-Book of Assaying." By C. and J. J. Beringer, revised by J. J. Beringer. Sixth Edition. 8vo, pp. 456. London. 1900.	Bennett H. Brough.
National Association of Colliery Managers. "Sources of Economy in Power Production." A Lecture delivered in Nottingham University College on February 29, 1908, by W. H. Patchell. (Reprinted from <i>Iron and Coal Trades Review</i> , March 6, 1908.) 4to, pp. 9.	The Author.
The Mayari and Daiquiri Iron Ore Mines of the Spanish-American Iron Company. (From articles published in the <i>Iron Age</i> , August 15, 1907, and April 8, 1908.) Fcap. 4to, pp. 16.	C. F. Rand.
"Jahresbericht des Vereins für die bergbaulichen Interessen im Oberbergamtsbezirk Dortmund für das Jahr 1907." I. (Allgemeiner) Teil. 4to. Essen-Ruhr. 1908.	The Society.
National Physical Laboratory. "Collected Researches." Vol. III., pp. 286. Teddington. 1908.	The Director.
National Physical Laboratory. "Collected Researches." Vol. IV., pp. 252. Teddington. 1908.	The Director.
National Physical Laboratory. Report for the Year 1907. 4to, pp. 97. Teddington. 1908.	The Director.
Statistisches Jahrbuch des k.k. Ackerbau Ministeriums für das Jahr 1901. 8vo, pp. 31. Vienna. 1904.	Bennett H. Brough.
Statistisches Jahrbuch des k.k. Ackerbau Ministeriums für das Jahr 1903. 8vo, pp. 201. Vienna. 1904.	Bennett H. Brough.
Les débuts de la Métallurgie du Tungstène par Paul Nicolardot. (Extrait de la <i>Revue de Métallurgie</i> , vol. v., No. 1, Jan. 1908.) 4to, pp. 23.	The Author.
"Thèses présentées à la Faculté des Sciences de Paris pour obtenir le grade de Docteur ès Sciences Physiques." Par Paul Nicolardot. 8vo, pp. 64. Paris. 1906.	The Author.
"Séparation et Dosage du Fer, du Chrome, de l'Aluminium, et du Vanadium." Par Paul Nicolardot. 8vo, pp. 13. (Mémoire récompensé par la Société Industrielle du Nord de la France et publié dans son Bulletin 1907.) Lille. 1907.	The Author.
"The History of Merthyr Tydfil." By C. Wilkins. 8vo, pp. 587. Merthyr Tydfil. 1908.	Sir W. T. Lewis, Bart., K.C.V.O. The Laboratory.
National Physical Laboratory. Report of the Observatory Department, 1907. 4to, pp. 45. Teddington. 1908.	The Author.
"Materialprovincingens Udvikling tale ved aarsfesten den 29 January 1908." By H. I. Hannover. 4to, pp. 24. Copenhagen. 1908.	The Under Secretary of State for Home Affairs. David Williams Co.
"Mines and Quarries." General Report and Statistics for 1907. Part I., "District Statistics." Fcap. folio. London. 1908.	
"Iron Age Directory." 8vo, pp. 341. New York. 1908.	

Title.	By whom Presented.
"Supplement to the Plotted Vertical Sections of the Northumberland and Durham Coalfields." By John Kirsopp, Jun. Fcap. folio, pp. 73. 1908.	The Author.
"The Geology of Coal and Coal-Mining." By Walter Gibson. 8vo, pp. 341. London. 1908.	Edward Arnold.
Mines and Quarries. General Report and Statistics for 1906. Part IV., "Colonial and Foreign Statistics." Fcap. folio, pp. 460. London. 1908.	The Under Secretary of State for Home Affairs.
"Zur Berechnung und Profilierung der Eisenhochöfen." By J. von Ehrenwerth. (Separatdruck aus der <i>Österreichischen Zeitschrift für Berg- und Huttenwesen</i> , 1908, No. 19.) 4to, pp. 4.	The Author.
"Jahrbuch der Österreichischen Berg- und Hüttenwerke, Maschinen- und Metallwarenfabriken," 1908. Herausgegeben von Rudolf Hanel. 8vo, pp. 2230. Vienna. 1908.	Bennett H. Brough.
"La Fabrication électrique des Aciers aux Aciéries Jacob Holtzer à Unieux (Loire)." By A. Keller. (Note présentée par la Compagnie Electro-Thermique, Keller, Leleux & Cie, au Congrès du Cinquantenaire de la Société de l'Industrie Minérale.) 8vo, pp. 14. Paris. 1908.	The Author.

INSTITUTIONS.

The Publications of the Institute are exchanged for those of the following Institutions:—

LONDON.

Board of Trade.
Chemical Society.
City and Guilds Institute.
Geological Society.
H. M. Patent Office.
Institution of Civil Engineers.
Institution of Electrical Engineers.
Institution of Mechanical Engineers.
Institution of Mining and Metallurgy.
Institution of Naval Architects.

Royal Artillery Institution.
Royal Institute of British Architects.
Royal Institution.
Royal Society.
Royal Statistical Society.
Royal United Service Institution.
Society of Arts.
Society of Chemical Industry.
Society of Engineers.
University College.

PROVINCIAL.

Birmingham University.
Cleveland Institution of Engineers.
Engineering Society, The University, Leeds.
Institution of Engineers and Shipbuilders in Scotland.
Liverpool Engineering Society.
Manchester Association of Engineers.
Manchester Geological and Mining Society.
Mining Institute of Scotland.
North-East Coast Institution of Engineers.

North of England Institute of Mining and Mechanical Engineers.
Royal Dublin Society.
Sheffield University.
South Staffordshire Ironmasters' Association.
South Wales Institute of Engineers.
Staffordshire Iron and Steel Institute.
University College of South Wales.
West of Scotland Iron and Steel Institute.

COLONIAL AND FOREIGN.**Colonial.**

Australasian Institute of Mining Engineers.
Canadian Institute.
Canadian Mining Institute.
Canadian Society of Civil Engineers.
Department of Mines, Melbourne.
Department of Mines, Sydney.
Geological Survey of Canada.
Geological Survey of India.
Geological Survey of New South Wales.
Mining Society of Nova Scotia.
Mysore Geological Department.
Royal Society of New South Wales.

United States.

American Association for the Advancement of Science.
American Foundrymen's Association.
American Institute of Mining Engineers.
American Iron and Steel Association.
American Society of Civil Engineers.

American Society of Mechanical Engineers.
Department of Labour.
Engineers' Society of Western Pennsylvania.
Franklin Institute.
Massachusetts Institute of Technology.
New York Academy of Sciences.
Ordnance Office, War Department.
School of Mines, Columbia College, New York.
Smithsonian Institution.
United States Geological Survey.

Austria.

K. K. geologische Reichsanstalt.
Oesterr. Ingenieur- und Architekten-Verein.

Belgium.

Association des Ingénieurs sortis de l'École des Mines de Liège.
Ministère de l'Intérieur.

1908.—i.

P

COLONIAL AND FOREIGN—*continued.*

France.

Pomité des Forges.
 Société d'Encouragement pour l'Industrie Nationale.
 Société de l'Industrie Minérale.
 Société des Anciens Élèves des Écoles Nationales d'Arts et Métiers.
 Société des Ingénieurs Civils.
 Société Scientifique Industrielle de Marseille.

Denmark.

Tekniske Foreningen.

Germany.

Deutsches Museum.
 Königliche Bergakademie in Freiberg.
 Königlichen Materialprüfungsamt.
 Verein Deutscher Eisenhüttenleute.
 (Journal "Stahl und Eisen.")
 Verein Deutscher Ingenieure.

Italy.

Reale Accademia dei Lincei.

Sweden.

Geological Institution of the University of Upsala.
 Jernkontoret.

JOURNALS.

The following periodicals have been presented by their respective Editors:—

UNITED KINGDOM.

<p>"Automobile Club Journal." "British Fire Prevention Committee." "Cassier's Magazine." "Coal and Iron." "Colliery Guardian." "Concrete and Constructional Engineering." "Contract Journal." "Electrical Engineer." "Electrical Review." "Electrician." "Engineer." "Engineer and Iron Trades Advertiser." "Engineering." "Engineering Review." "Engineering Times." "Hardware Trade Journal." "Hardwareman." "Horological Journal." "International Marine Engineering." "Iron and Coal Trades Review." "Iron and Steel Trades Journal."</p>	<p>"Iron Trade Circular." "Ironmonger." "Kynoch Journal." "Machinery Market." "Marine Engineer." "Mechanical Engineer." "Navy League Journal." "Page's Weekly." "Petroleum Review." "Phillips' Monthly Register." "Plumber and Decorator." "Practical Engineer." "Quarry." "Railway Times." "Science and Art of Mining." "Shipping World." "South African Engineering." "Statist." "Syren." "Tramway and Railway World." "Vulcan."</p>
---	--

COLONIAL AND FOREIGN.

Colonial.

"Canadian Mining Journal."
 "Indian Engineering."
 "Indian Textile Journal."
 "New Zealand Mines Record."

United States.

"American Journal of Science."
 "American Machinist."
 "Bradstreets."

"Electrochemical and Metallurgical Industry."
 "Engineering and Mining Journal."
 "Engineering Magazine."
 "Engineering News."
 "Industrial World."
 "Iron Age."
 "Iron Trade Review."
 "Machinery."
 "Mines and Minerals."
 "Mining World."
 "Power."
 "Railroad Gazette."

COLONIAL AND FOREIGN—*continued.*

Austria.

“ Oesterr. Zeitschrift für Berg- und Hüttenwesen.”

Belgium.

“ Bulletin de l'Union des Charbonnages de Liège.”
 “ Moniteur des Intérêts Matériels.”
 “ Revue Universelle des Mines.”
 “ Technical Index.”

France.

“ Annales des Mines.”
 “ L'Echo des Mines.”
 “ La Revue Minéralurgique.”
 “ Le Génie Civil.”
 “ Le Mois Scientifique et Industriel.”
 “ Portefeuille Economique.”

Germany.

“ Annalen für Gewerbe und Bauwesen.”
 “ Chemiker Zeitung.”
 “ Eisen-Zeitung.”
 “ Glückauf.”

“ Metallurgie.”

“ Verein Deutscher Eisen- und Stahl-Industrieller.”

“ Zeitschrift für das Berg-, Hütten- und Salinenwesen im preussischen Staate.”

“ Zeitschrift für praktische Geologie.”

“ Zeitschrift für Werkzeugmaschinen und Werkzeuge.”

“ Zentralblatt für Eisenhüttenwesen.”

Italy.

“ L'Industria.”

“ Rassegna Mineraria.”

Peru.

“ Cuerpo de Ingenieros de Minas.”

Spain.

“ Gaceta Minera de España.”

“ Revista Minera.”

Sweden

“ Teknisk Tidskrift.”

“ Svensk Export.”

DINNER TO MR. R. A. HADFIELD, PAST-PRESIDENT.

On May 13 Mr. R. A. Hadfield was entertained to dinner by the Council at the Grand Hotel. In addition to the guest of the evening, the company consisted of Sir Hugh Bell, Bart., President, in the chair; the Right Hon. Lord Airedale, Past-President; Mr. E. Windsor Richards, Past-President; Mr. E. P. Martin, Past-President; Mr. W. H. Bleckly, Hon. Treasurer; Mr. P. C. Gilchrist, Mr. James Riley, and Mr. A. T. Tannett-Walker, Vice-Presidents; Mr. G. Ainsworth, Mr. D. Colville, Mr. J. H. Darby, Mr. W. Evans, Mr. J. M. Gledhill, Mr. W. H. Hewlett, Sir Alfred Hickman, Bart., Mr. A. Lamberton, Mr. J. E. Stead, F.R.S., Mr. J. M. While, Members of Council, and Mr. Bennett H. Brough, Secretary. The dinner, which should have been held in May 1907, was postponed owing to Mr. Hadfield's absence in the United States, where he acted as representative of the Iron and Steel Institute at the opening of the Carnegie Institute.

SECTION II.

*NOTES ON THE
PROGRESS OF THE HOME AND FOREIGN
IRON AND STEEL INDUSTRIES.*

CONTENTS.

	PAGE		PAGE
IRON ORES	230	FURTHER TREATMENT OF IRON AND	
REFRACTORY MATERIALS	251	STEEL	357
FUEL	255	PHYSICAL PROPERTIES	374
PRODUCTION OF PIG IRON	308	CHEMICAL PROPERTIES	399
PRODUCTION OF MALLEABLE IRON	332	CHEMICAL ANALYSIS	412
FORGE AND MILL MACHINERY	341	STATISTICS	421
PRODUCTION OF STEEL	348	BIBLIOGRAPHY	448

In the preparation of these Notes the Editor has been assisted by L. P. SIDNEY
and by THOMAS TWYNAM.

IRON ORES.

CONTENTS.

	PAGE
I. Occurrence and Composition	230
II. Iron Ore Mining	242
III. Mechanical Preparation	248
IV. Metallurgical Preparation	25

I.—OCCURRENCE AND COMPOSITION.

Formation of Ore Deposits.—H. V. Winchell* discusses the genesis of ore deposits in the light of modern theory, and considers the influence of mass, time, average temperature, climate, topography, physical structure, and depth of soil as factors in enrichment. Glaciation is referred to as an agent in the formation of ore deposits, the influence of which has been insufficiently regarded by most investigators.

E. Bodifée † discusses the genesis of the iron and manganese ore deposits at Oberrosbach in the Taunus.

The mode of formation of the iron ores of Central Sweden is discussed at considerable length by H. Johansson. ‡

Nomenclature of Ore Deposits.—Henry Louis § directs attention to a deficiency in the nomenclature of mineral deposits, proposing that the word “pitch” should be definitely restricted to the obliquity of the axis of an ore shoot or of a lenticular mass.

Iron Ore in Great Britain.—W. G. Fearnside || discusses the occurrence of the well-known iron ores of Carnarvon and Merioneth, and shows that, although they have been taken by various writers as marking a well-constituted subdivision of the Tremadoc slates, they are really of the nature of fissure phenomena, and may occur at almost

* *Engineering and Mining Journal*, vol. lxxxiv. pp. 1067-1070.

† *Zeitschrift für praktische Geologie*, vol. xv. pp. 309-316.

‡ *Geologiska Föreningens Förhandlingar*, vol. xxiv. pp. 143-186.

§ *Transactions of the Institution of Mining Engineers*, vol. xxxiv. pp. 236-238.

|| *Report of the Seventy-seventh Meeting of the British Association*, London, 1908, pp. 510-511.

any horizon. The probable petrological and chemical history of the iron ores is also discussed.

The owners of the Lindal Moor mines, in Furness, have discovered two extensive deposits of iron ore on their royalty. These are likely to prove a great advantage to the trade of the district, as in recent years some of the important mines have been showing signs of exhaustion, and it has become necessary to import foreign ores. One of the new finds has been proved to contain a deposit over 30 feet deep of rich ore, within easy reach of the surface, and the other discovery is not less important.*

R. W. Dron † discusses the iron ore resources of Shetland. The western part of the side of the island is composed of Archæan Schists rising in hills to a height of between 800 and 900 feet, and along the eastern coast there is a stretch of flaggy sandstones of Old Red Sandstone age. The principal metalliferous veins are situated either in the Old Red Sandstone or at the contact between the sandstones and the schists. The only serious mining operations that have been carried out were made at Sandlodge, on the east coast, twelve miles from Lerwick. The vein appears to be composed principally of chalybite (or siderite). At the surface there is the usual alteration to brown hæmatite iron ore. The west shaft was sunk on the incline of the vein to a depth of 180 feet. For the first 100 feet it consisted of hæmatite with rich pockets of copper pyrites. Several thousand tons of this ore, which were said to contain 64 per cent. of iron, were shipped. Below the 100-foot level the ore assumed the form of light brown spathic ore. The material shipped contained 35 per cent. of iron, with 15 per cent. of lime and magnesia, and it was also accompanied by copper pyrites. The ore body, exposed in these lower workings, appears to have consisted of white chalybite (siderite), with chalcopyrite. The occurrence of siderite as a white ore is rather uncommon. In appearance it is very much like calcite, and it might be mistaken for that mineral. Analysis of this ore gave 3 to 4 per cent. of copper, and 30 to 40 per cent. of iron, with a small percentage of manganese. Following the line of the vein to the south, five specimens of chalcopyrite are found in the cliffs at No Ness Head. To the north a vein was discovered at Setter, about half a mile from Sandlodge.

Iron Ore in Austria.—K. A. Redlich ‡ describes the iron ore mines in the vicinity of Payerbach-Reichenau, in Lower Austria. He gives an account of the history of the mines, with details of production, and describes the geological features of the iron ore deposits at Grillenberg, Priggwitz, Hirschwang, Altenberg, and Schendlegg. The composition of the ores is stated, and the genesis of the deposits discussed. The history of mining operations is traced back to the year 1546.

* *Engineering*, vol. lxxxv. p. 403.

† Paper read before the Geological Society of Glasgow; *Iron and Coal Trades Review*, vol. lxxv. p. 1945.

‡ *Berg- und Hüttenmännisches Jahrbuch der k. k. montanistischen Hochschulen*, vol. lv. pp. 267-294.

T. F. von Hassler * gives particulars of the ore occurrences in the Ortler district. Some deposits of very pure iron ore, containing 83·3 per cent. of ferric oxide, are met with. The deposits were worked at the end of the eighteenth century.

Ahlburg † describes the ore-mining industry of Styria, Carinthia, and Carniola. He gives an excellent coloured geographical map of the Eastern Alps, and numerous diagrams illustrating the occurrence of ore and the method of ore-dressing in vogue. Descriptions are given of the iron ore mines of the Eastern Alps (the Styrian ore mountain, Hüttenberg in Carinthia, iron ores in the Karawanken), the manganese mines at Vignusica, of the chrome iron ore mines of Kraubat, and of the graphite mines of Upper Styria.

Iron Ore in Bosnia.—The mineral resources of Bosnia and Herzegovina are exhaustively described by A. Galocsy. ‡

Iron Ore in France.—M. Oehlert § describes the Ordovician iron ores of Normandy and Maine.

Iron Ore in Germany.—Robert Fluhr || describes the iron ore deposits of Württemberg. He gives an account of the geology of the various deposits, the brown iron ore veins in the Bunter sandstone at Neuenburg, the oolitic clay ironstones in the Koche valley, and the Tertiary pisolitic iron ores. Numerous analyses are given, and the economic importance of the deposits are discussed.

Willert ¶ describes the clay ironstone of Ahaus and Koesfeld.

An account is given ** of the extensive deposits of bog iron ore recently discovered in Pomerania.

Iron Ore in Greece.—N. Bonanos †† gives a geological description of the various deposits (deposits in limestone and contact-deposits) of chrome iron ore in Greece.

A. Habets ‡‡ discusses the geological age of the Lokris deposits.

Iron Ore in Italy.—F. Millosevich §§ gives a mineralogical description of the lamellar hæmatite occurring at Padria in Sardinia.

Iron Ore in Norway.—An account has appeared |||| of the South Varanger iron deposits, situated on the Pasvik peninsula at Varangerfiord, in the province of Finmark. The deposits cover an area of nearly

* *Montan Zeitung*, vol. xiv. pp. 338-340.

† *Zeitschrift für das Berg-, Hütten- und Salinenwesen*, vol. lv. pp. 463-521.

‡ *Banyaszati es Kohaszati Lapok*, vol. xli. p. 201-288.

§ *Comptes Rendus*, vol. cxlvi. pp. 515-517.

|| *Zeitschrift für praktische Geologie*, vol. xvi. pp. 1-23.

¶ *Glückauf*, vol. xlv. pp. 304-309.

** *Erzbergbau*, vol. iii. p. 405.

†† *Revue Universelle des Mines*, vol. xxi. pp. 139-148.

‡‡ *Ibid.*, pp. 129-138.

§§ *Rendiconti della Reale Accademia dei Lincei*, vol. xvi., Part I., pp. 884-889.

|||| *Iron and Coal Trades Review*, vol. lxxvi. p. 421.

3000 acres, and the ground consists principally of gneiss and granite. The iron ore is found in the gneiss mixed with basic eruptives, from which the ore probably originates, and also quartzite, and occasionally other rocks. The ore strikes N.W.—S.E., and the dip varies from 40 degrees to 70 degrees in an easterly direction.

Within the area there are many different deposits, of which the Björnevärd is one of the most important. Here the deposits have been found to be up to 200 yards wide, with an area of ore of about 400,000 square yards, and a depth of 100 yards, proved by the borings, the quantity of ore available being estimated at 150 million tons. In this deposit there is comparatively very little rock, mostly dykes of gabbro, and the ore is estimated to represent 90 per cent. of the total mass. In other places the ore is found in numerous parallel deposits, where the average content of ore, of course, is lower. The total area of ore in the deposits is estimated at about $1\frac{1}{4}$ million square yards, and the total quantity, to a depth of only 100 yards, at about 400 million tons, as a minimum. In consideration of the large area, it ought not to be any exaggeration to estimate the total workable quantity of ore at about 1000 million tons.

The deposit consists exclusively of magnetic ore, and the rocks most frequently found are quartz and hornblende. In some parts the quartz is the most prominent, in others the hornblende minerals, thus dividing the ore into two different types. The whole mass may be said to consist nearly exactly of 50 per cent. magnetite and 50 per cent. gangue, the content of metallic iron being about 36 per cent. In some parts there is also found ore with an iron content of 50 per cent. or more, although this is exceptional.

Iron Ore in Russia.—The celebrated iron ore deposit of Krivoi Rog in South Russia is described by F. Thiess.*

Numerous analyses of Russian iron ores are given by F. Gervais.†

Iron Ore in Spain.—O. Pütz ‡ describes the iron ore deposits of the South of Spain.

Iron Ore in Sweden.—R. Bärtling § gives an exhaustive description of the iron ore deposits of North Sweden, with special reference to the chemical composition of the ores and the reserves available.

W. Petersson's work || on the iron ore deposits in the neighbourhood of Jukkasjärvi and Gellivare, in the Swedish district of Norrbotten, is reviewed.¶ The information published deals fully with the following ore deposits:—

A. *Kiirunavaara*.—This immense deposit occurs in a range of hills about 2·8 kilometres long, the highest point in the range being 748

* *Oesterreichische Zeitschrift für Berg- und Hüttenwesen*, vol. lv. pp. 608-609.

† *Gorni Journal*, 1907, p. 73.

‡ *Erzbergbau*, vol. iii. pp. 408-410.

§ *Zeitschrift für praktische Geologie*, vol. xvi. pp. 89-108.

|| *Jernkontorets Annaler*, vol. lxii. pp. 238-308.

¶ *Stahl und Eisen* vol. xxvii. pp. 1571-1576.

metres above sea-level. Analyses from various points are given, and other minerals found in association with the ore described. Exploratory work is still being continued. An approximate estimate of the total amount of ore existing in this deposit, both proved and that supposed to exist below sea-level, has placed the amount at 480 million tons of ironstone. Of this amount some 200 million tons exists above sea-level.

A. Luossavaara.—The ores found in this deposit do not occur in such large quantities as in the previous one, nor have they been so extensively worked. The deposit is some 1270 metres long, the highest point being 229 metres. Analyses and approximate estimation of quantities are given.

H. Sjögren * discusses, at some length, the geological relations of the iron ores of Scandinavia. He classifies the ores of the peninsula into six groups: (1) The ores of the Archæan crystalline schists; (2) the ores of the porphyries (keratophyres); (3) those of the basic eruptive rocks; (4) ores occurring in the metamorphosed Cambro-Silurian schists; (5) contact-formations connected with acid eruptive rocks of post-Silurian age; and (6) lake and bog ores. Each group is then dealt with separately, their geological relations and mineralogical characters being fully described. The lake and bog ores formed the raw material for the oldest iron industry in Scandinavia long before blast-furnaces were known, and were called Tophus Tubalcaini by Carl Linnæus, after Tubal Cain, the first blacksmith. The purer lake ores generally contain from 50 to 60 per cent. of ferric oxide, 10 to 15 per cent. of water, and sometimes a considerable amount of manganese (up to 20 per cent.). Both the phosphorus and sulphur are usually high.

Iron Ore in Turkey.—A recent article † on the mineral resources of Macedonia shows that, although the country is rich in minerals, mining remains in an undeveloped condition. Iron ore is abundant, but coal is lacking.

Iron Ore in Canada.—In an illustrated description of the mines of Ontario, E. T. Corkill ‡ gives an account of the Helen mine, which continues to hold the premier position in the production of iron ore in Ontario, of the Moose Mountain iron ore deposit, of the Radnor iron ore mine, and of the Mineral Range mines. He also describes the nickel mines of the Sudbury district. A. P. Coleman § describes the iron ranges east of Lake Nipigon, and E. S. Moore || gives some particulars of the ranges around Lake Windegokan.

In a report on the geology of the counties of Pontiac, Carleton, and Renfrew, R. W. Ellis ¶ states that the only workable deposits of iron ore yet found in this area are at the Bristol mines in Pontiac county,

* *Bi-Monthly Bulletin of the American Institute of Mining Engineers*, 1907, pp. 877-946

† *Montan Zeitung*, vol. xv. p. 10.

‡ *Annual Report of the Bureau of Mines*, Toronto, vol. xvi. pp. 55-91.

§ *Ibid.*, pp. 105-135.

|| *Ibid.*, pp. 136-148.

¶ *Geological Survey of Canada, Bulletin No. 977*, pp. 39-41.

Quebec, where the ore is a magnetite, occurring in lenticular masses, some of which are of considerable extent. The associated rocks are micaceous and hornblende schists, cut by reddish granite. The ore contains 58.37 per cent. of iron, 1.46 per cent. of sulphur, and only traces of phosphorus. Over 10,000 tons of the ore have been iron.

G. C. Hoffman * gives analyses of fourteen samples of iron ore (clay ironstone, bog iron ore, and hæmatite) from various localities in Canada.

J. E. Woodman † reports on the iron ore deposits of Nova Scotia, Western Ontario, and the Ottawa Valley, respectively. The Torbrook Nictaux Basin is the most promising iron field in Nova Scotia. The country is open, substantial water power at Nictaux Falls awaits utilisation, transportation is easy, and within a few miles an abundance of hardwood timber is available. The basin is described as either a large syncline or a succession of smaller folds, the axes of which run approximately north 55 degrees east to north 60 degrees east. The ore is interstratified, having replaced limestone beds. High grade hæmatites and siliceous magnetites are found in large quantities. All of the ore is phosphatic, and most of it carries from 2 to 8 per cent. of lime. The Arisaig deposits of Antigonisa county run east and west for a distance of five and a half miles. The Arisaig bedded hæmatites occur in nearly vertical veins, and, so far as known, are continuous for a great length on the strike. Vertical sections of the highest and lowest exposures give a depth of 350 feet. No drilling has been done to prove the deposits to greater depth. In the western part of the field the ore is less siliceous and freer from trap intrusions. All of the ore averages under 50 per cent. of iron in wagon-load lots.

The progress of iron ore mining in the province of Quebec is described by H. M. Lamb.‡

Iron Ore in India.—L. L. Fermor § describes an interesting apatite-magnetite rock from the Singhbhum district, Bengal. The apatite occurs as spots, up to half-an-inch in diameter, in what would otherwise be called magnetite. The rock might prove of value in the manufacture of basic iron.

Iron Ore in Western Australia.—With the object of helping prospectors, the Geological Survey of Western Australia has compiled a Bulletin (No. 30) giving particulars of the distribution and occurrence of the ores of metals other than gold. The Bulletin, which covers 129 pages, has been written by E. S. Simpson and C. G. Gibson, and includes details of the occurrence in Western Australia of ores of iron, nickel, cobalt, manganese, tungsten, and molybdenum.

* *Geological Survey of Canada, Bulletin No. 958*, pp. 43-47.

† *Annual Report of the Department of the Interior*. Nova Scotia, 1907.

‡ *Engineering and Mining Journal*, vol. lxxxiv, pp. 1160-1161.

§ *Records of the Geological Survey of India*, vol. xxxvi, p. 128.

Iron Ore in New Zealand.—J. M. Bell * describes the geology of the Parapara Sub-division, Karamea, Nelson. The deposit of iron ore situated on the shores of Parapara Inlet is described in detail. This great deposit of iron ore has been left practically untouched up to the present time, and the author advocates the erection of blast-furnaces on the spot and the construction of a wharf to the north of Tukurua Point. The iron ore is of high grade, and phosphorus, sulphur, and other impurities do not occur in serious quantities. Mineralogically, the ore is mainly limonite, though partly göthite and possibly turgite. It occurs in three enormous blocks, the amount in the Washbourn block being estimated at not less than 22,691,762 tons. In the thirty-four samples taken from this block the average iron content was 51.79 per cent.

A sample of the Parapara ore has been analysed at the Imperial Institute. The analysis gave results indicating that the ore is probably a mixture of the two minerals göthite and limonite. There is no doubt that this ore from Parapara would be suitable for smelting locally if supplies of limestone and coal were available in the neighbourhood.

Iron Ore in Natal.—According to the official report of the mining industry of Natal, arrangements are in progress for opening up the deposits of iron ore to the north-east of Hlobane Mountain, and for the construction of a railway extension from Vryheid to these deposits and the establishment of iron and steel works. It is estimated that the iron ore deposits would yield 3,589,000 tons, sufficient for the requirements of a small plant making 50,000 tons of pig iron per annum for thirty-five years. Analyses indicate that the ore would yield good iron. For its conversion into steel, the basic open-hearth process would probably be most suitable, the percentage of phosphorus being too high for the acid Bessemer or acid open-hearth processes, and too low for the basic Bessemer process.

Iron Ore in British East Africa.—A sample of iron ore, weighing about 1 lb. and consisting of irregularly-shaped brownish lumps of magnetite, that was collected near Voi Station on the Uganda Railway, gave on analysis the following results:—†

	Per Cent.	
Fe ₂ O ₃	66.98	} = 63.2 per cent. iron.
FeO	21.01	
MnO	0.26	
CaO	0.33	
BaO	0.62	
MgO	0.25	
TiO ₂	8.70	= 5.2 per cent. titanium.
SiO ₂	1.42	
P ₂ O ₅	0.03	= 0.013 per cent. phosphorus.
SO ₃	0.02	= 0.008 per cent. sulphur.
H ₂ O	0.55	

* *New Zealand Geological Survey, Bulletin* No. 3, 111 pages, with 14 maps, 3 sheets of sections, and 26 plates. Wellington, 1907.

† *Bulletin of the Imperial Institute*, vol. v. pp. 240-241.

Iron Ore in Nyassaland.—The report on the results of the mineral survey in the Nyassaland Protectorate by Wyndham R. Dunstan has been published as a Parliamentary White Paper. The iron ores found are principally mixtures of hæmatite and magnetite. The best iron ore received was a sample of magnetite from the Pokonyowa Valley. This contains an equivalent of 71 per cent. of iron, and is free from phosphorus and sulphur. A concretionary iron ore from the Sumbu district proved to be of medium quality, and the extent of the deposit of this is considered important by the assistant surveyor. Most of the other iron ores received are titaniferous, and therefore of little value. The organisation of a local smelting industry in ordinary blast-furnaces might be possible if suitable coal were available in the neighbourhood.

Iron Ore on Lake Superior.—The bulk of the iron ore smelted in American furnaces is obtained from the Mesaba, Menominee, Marquette, Vermillion and Gogebic ranges, the quantity mined in the Mesaba district being more than that of the others combined. Such is the extent of the deposits on the Mesaba range, that the recent transfer of a very large area of this range to the United States Steel Corporation embraces only a small portion of this territory, although it covers 80,000 acres. On the one-fourth of this area examined about 100,000,000 tons have been measured. This contains the necessary percentage of iron to give a Bessemer grade, and is so accessible that it can be reached by surface excavation. The railway and ore transporting arrangements are dealt with in detail.*

G. E. Edwards † describes the ore deposits and changes in methods of mining which will necessitate the removal of the village of McKinley and other towns in the Mesaba iron ore range built on iron ore foundations.

O. J. Abell ‡ describes the development of iron ore mining in the Lake Superior district during the year 1907.

Recent development on some of the old range mines on the Menominee are described.§ The Antoine mine has opened up new deposits of hard siliceous ore containing about 40 per cent. each of iron and silica.

The limits of the Mesaba iron-bearing belt are being gradually extended west of the Mississippi. Merchantable ore has been found west of the west bank of Pokegama Lake, about five miles southwest of Grand Rapids, and a good deal of drilling is in progress west and south from there. This marks an important advance in the geological knowledge of the Mesaba formation, for until recently no merchantable ore had been found west from Grand Rapids.||

* *Times Engineering Supplement*, November 20, 1907, p. 6.

† *Mining World*, vol. xxviii, pp. 65-66.

‡ *Iron Trade Review*, vol. xliii, pp. 95-99.

§ *Ibid.*, vol. xli, pp. 659-662.

|| *Engineering*, vol. lxxxv, p. 718.

Iron Ore in Minnesota.—D. E. Woodbridge* discusses the iron ore resources of Minnesota. Exploration has been carried out around Deerwood and in other parts of northern Crow Wing county, with the result that merchantable grades of ore have been located. Samples taken from trial borings on Rabbit Lake Shore have yielded on analysis 63 to 66·04 per cent. of iron and 0·110 to 0·134 per cent. of phosphorus. In proximity to the Rabbit Lake deposits, ore has been found at depths of about 1200 feet, but the deposits appear low grade, averaging only 40 to 45 per cent. of iron, and high in phosphorus. The geological character of the whole district is one of morainic till and glacial drift deposition.

Iron Ore in the Adirondack Region.—D. H. Newland† discusses the associations and origin of the non-titaniferous magnetites of the Adirondack region.

Iron Ore in Rhode Island.—B. L. Johnson‡ and C. H. Warren give some notes on the history and geology of Iron Mine Hill, Cumberland, and describe the petrography and mineralogy of the deposit.

Iron Ore in Wyoming.—B. W. Vallet§ describes the occurrence of hæmatite replacing schist at the Sunrise mine, Hartville range.

Iron Ore in Cuba.—C. Catlett|| describes a brown hæmatite deposit in the Pinar del Rio province. The deposit is probably a replacement of limestone. Barytes crystals are widely distributed throughout the deposit, there being in some cases as much as 10 per cent. of barium sulphate in the ore.

Iron Ore in Mexico.—Discoveries of large bodies of iron ore are reported to have been made in the State of Colima, Mexico. The deposit is stated to be not only very extensive, but of good quality.¶

Iron Ore in Peru.—E. J. Dueñas** describes the occurrence of deposits of excellent iron ore in the department of the Cuzco. At Livitaca, in the province of Chumbivilcas, red hæmatite occurs in considerable quantity. The Yanaccaca hill is estimated to contain 450,000 tons of ore yielding 55 per cent. of iron.

Iron Ore in Tunis.—According to K. Roberty †† there are five important deposits of iron ore, all of which occur in the north-west of

* *Engineering and Mining Journal*, vol. lxxxiv. pp. 775-776.

† *Economic Geology*, vol. ii. pp. 763-773.

‡ *American Journal of Science*, vol. xxv. pp. 1-38.

§ *Proceedings of the Colorado Scientific Society*, vol. viii. pp. 315-322.

|| *Bi-Monthly Bulletin of the American Institute of Mining Engineers*, 1907, pp. 623-624.

¶ *American Machinist*, vol. xxx. Part II. p. 832.

** *Boletín del Cuerpo de Ingenieros de Minas del Perú*, No. 53, pp. 136-137.

†† *L'Industrie Extractive en Tunisie*. Tunis, 1908.

Tunis. Those near to Tabbarca are pyritic in depth, but oxidised on the surface. The ore occurs in irregular lenticular-shaped masses in strata of Eocene age. That of Djebel-Djerissa is estimated to contain 15,000,000 tons, and is free from sulphur and phosphorus. West of this is the deposit of Djebel Slata, containing 6,000,000 tons of similarly pure ore, and that of Djebel-Hameima, which is a phosphoric ore. The total annual productive capacity of these mines is probably not far short of a million tons.

Iron Ore in Togo.—The iron ore bed of Bangeli in Togo is described by W. Koert.*

Manganese Ore in Hungary.—H. Drucker† describes the extensive beds of manganese ore discovered at Ledecz-Rovny in Trencsen county. The ore contains 25 to 32 per cent. of manganese.

Manganese Ore in Russia.—R. Grimshaw‡ gives an account of recent discoveries of manganese ore in the Caucasus, near Samtredi, on the Trans-Siberian Railway, and at Michailovska, in the district of Yelisavetpol.

Published analyses§ of Russian manganese ores show 46·90 to 51·55 per cent. of manganese, 7·77 to 15·64 per cent. of silica, 0·06 to 0·23 per cent. of phosphorus, and 0 to 0·10 per cent. of sulphur.

Manganese Ore in Spain.—R. Michael|| describes the manganese ore deposits in the vicinity of Ciudad Real. The ore contains 50 to 54 per cent. of manganese and the deposits are very extensive.

Manganese Ore in India.—L. L. Fermor¶ deals exhaustively with the subject of manganese in India. An account of the mineralogy and geology of the ore deposits generally is followed by a detailed description of the various deposits classified according to the nature and formation of the ores contained in them. A sketch of the history of the subject is given, and then a general description of the methods of working, especially at Kandri, Balaghat, and Kajlidongri. Economic matters concerning labour, transport, prices, and distribution also receive consideration. Maps of India showing the distribution of the ores are appended.

Manganese Ore in Cape Colony.—It is stated that** an important discovery of manganese has recently been made at Caledon,

* *Ersbergbau*, vol. iv. pp. 80-82.

† *Oesterreichisch-Ungarische Montan- und Metall-Industrie Zeitung*, October 27, 1907.

‡ *Engineering and Mining Journal*, vol. lxxxiv. p. 1158.

§ *Gorni Journal*, 1907, pp. 85-86.

|| *Zeitschrift für praktische Geologie*, vol. xvi. pp. 129-130.

¶ *Transactions of the Mining and Geological Institute of India*, vol. i. pp. 71-131, 221-233.

** *Cape Times*, December 18, 1907; *Board of Trade Journal*, vol. lx. p. 138.

Cape Colony. The ore contains as much as 42 per cent. of metal, and it is estimated that the amount of the deposit is about 30,000 tons. It is favourably situated for transport by gravitation to the railway line.

Manganese Ore in New South Wales.—A deposit of manganese ore, about eighteen miles from Orange, New South Wales, is described.* It is an outcropping deposit, beneath which is a red oxide of iron formation, 2 feet 6 inches in width, in the form of fairly fine powder. The surface formation is stated to carry about 75 per cent. of manganese, 2 dwt. of gold, and 4 to 5 ounces of silver; the red oxide shows traces only of gold and silver. The powdery deposit is in two distinct seams of colouration—one purple and the other brown. A portion of the deposit is intermixed with small lenticular veins of unoxidised red hæmatite, and, when ground up, it is said to be richest in colouration. The Standard Paint Company are experimenting with the material with a view to the manufacture of paint.

Manganese Ore in the Portuguese Colonies.—R. A. Becher † states that the discovery of manganese ore in the colony of Goa has led to considerable enterprise in mining this ore, and during the year 1907 some quantity of ore was exported. The interesting geological formations in many parts of the country lead to the belief that mining enterprise in Goa should not stop at manganese.

Ores of the Rare Metals.—A. Haenig ‡ describes the occurrence and production of the ores of the rare metals, cobalt, vanadium, molybdenum, titanium, uranium, and tungsten, with special reference to their employment in the steel industry.

Tungsten Ore.—The tungsten ore deposits of Boulder county, Colorado, are described by Waldemar Lindgren.§ The deposits are quartz veins containing wolfram.

They are also described by W. E. Greenawalt,|| who states that the ore is a breccia of wolfram and felspar, occurring in connection with andesite dykes.

Nickel Ore in New Caledonia.—G. Dieterich ¶ describes the economical development of New Caledonia, formerly a French convict station. The most important mineral deposits are those of nickel ore, and contain on an average about 5 per cent. of nickel. The most important mining district is the Bornet mountain plain, where auxiliary wire ropeways feed a main Bleichert ropeway, which carries the

* *Sydney Morning Herald*; *Board of Trade*, vol. lix. p. 578.

† *Board of Trade Journal*, vol. lx. pp. 292-293.

‡ *Oesterreichische Zeitschrift für Berg- und Hüttenwesen*, vol. lvi. pp. 177-180 et seq.

§ *Economic Geology*, vol. ii. pp. 463-463.

|| *Engineering and Mining Journal*, vol. lxxxiii. pp. 951-952.

¶ *Zeitschrift des Vereines deutscher Ingenieure*, vol. li. pp. 1805-1815, 1858-1867.

ore to bins at the railway terminus. The railway carries the ore to storage bins at a central station of a system of ropeways on the coast at Thio. The ore is then carried either to storage heaps, where it can be reloaded for shipment, or taken direct to the vessels at a landing station, 3280 feet from the shore, by a wire ropeway passing over the sea.

Vanadium Ore.—J. J. Bravo* gives details of the extensive vanadium ore deposits discovered in Peru. The ore contains 15·36 per cent. of vanadium. Another authority † gives 16·08 per cent.

Magnetite.—B. J. Harrington ‡ describes some examples of isomorphism exhibited by magnetite from Quebec, Arkansas, and Nova Scotia.

Native Iron.—Otto Vogel § gives a historical review of reported discoveries of native iron. In 1803 J. L. Jordan described a lump of native malleable iron, weighing 3 to 4 lbs., from Kirberg, and C. A. Gerhard in 1776 noted the occurrence of native iron at Grosskammsdorf, Saxony, and at Steinbach near Eibenstock, and at Tarnowitz in Upper Silesia. Other discoveries recorded appear to have been artificial products.

Native Iron-Nickel Alloy.—C. G. Hoffmann || describes a native iron-nickel alloy occurring in the auriferous gravels of the Fraser river, British Columbia. It contains 76·48 per cent. of nickel, 22·30 per cent. of iron, and 1·22 per cent. of copper. The author suggests that this mineral be named "souesite," after the gentleman who sent the sample for identification, to distinguish it from other naturally occurring iron-nickel alloys.

Recent Researches on Meteorites.—In his annual report on the progress of mineralogical chemistry, A. Hutchinson ¶ refers to the Hendersonville meteoritic stone, which was found in 1901. Its mineralogical composition is: nickel-iron 2·59, troilite 4·43, schreibersite 0·08, chromite 0·80, olivine 40·48, and pyroxene 51·62 per cent.

E. Goldsmith** describes a meteoric stone which was seen to fall on April 30, 1906, on the New Jersey shore. On analysis the stone yielded 44·36 per cent. of iron, 42·80 per cent. of silica, 4·18 per cent. of alumina, 2·00 per cent. of nickel oxide, 1·90 per cent. of titanitic acid, and 1·84 per cent. of carbon.

* *Boletin del Cuerpo de Ingenieros de Minas del Peru; Oesterreichische Zeitschrift für Berg- und Hüttenwesen*, vol. lvi. pp. 166-168.

† *Echo des Mines*, vol. xxxv. p. 55.

‡ *Mineralogical Magazine*, vol. xiv. pp. 373-377.

§ *Chemiker Zeitung*, vol. xxxi. pp. 1181-1182.

|| *Geological Survey of Canada, Bulletin No. 958*, pp. 9-11.

¶ *Annual Reports of the Progress of Chemistry*, vol. iv. p. 310.

** *Journal of the Franklin Institute*, vol. clxiv. pp. 369-373.

Further investigations of the Cañon Diablo meteorites have been made by G. P. Merrill* and W. Tassin.

L. L. Fermor † gives detailed particulars of the meteoric shower of October 22, 1903, at Dokachi, Bengal. He also ‡ gives an account of four previously unrecorded meteorite falls in India.

II.—IRON ORE MINING.

Deep Boring.—A translation has been published § of a paper by T. Tecklenburg suggesting that endeavours should be made to obtain utilisable electric energy from the earth's interior by means of deep boreholes.

W. Eminger || describes the precautions to be taken to protect the screw-threads of boring tubes in transport.

G. Koerner ¶ describes apparatus for measuring the dip of strata in a borehole, and for measuring the deviation of boreholes from the vertical.

K. Haussmann ** describes a new apparatus for plumbing boreholes.

For boring to a depth of 100 yards at the iron ore deposits in the Goslar district a 5 horse-power petrol motor has been successfully used, with hollow rods for the extraction of cores. The plant can be taken down and set up again within two days. The derrick is only 20 feet high. Four men suffice for attendance, and 7 to 10 yards can be bored in fairly hard cretaceous marl in a ten-hour shift. ††

Shaft-sinking.—G. C. Stoltz ‡‡ describes the sinking of the Clonan shaft at Mineville, New York. It is situated on the property of the Port Henry Iron Ore Company, and gives access to the large magnetic ore deposit in mine 21. In order to handle 1500 tons per day the shaft is to be sunk 500 feet vertically, cross cuts being driven at 80-foot intervals to the ore body. When 50 feet had been sunk a flow of water was encountered, and as the ground did not stand well concrete was resorted to. The method of applying the concrete, and the results, are described.

Explosives and Blasting.—The preparation of boreholes for blasting is described by W. Beckmann §§

* *Smithsonian Miscellaneous Collections*, vol. iv. pp. 203-215.

† *Records of the Geological Survey of India*, vol. xxxv. pp. 68-78.

‡ *Ibid.*, pp. 79-96.

§ *Transactions of the Institution of Mining Engineers*, vol. xxxiv. pp. 484-493.

|| *Revue du Pétrole*, vol. i. p. 105.

¶ *Mining Journal*, vol. lxxxiii. pp. 63-64.

** *Glückauf*, vol. xlv. p. 231.

†† *Zeitschrift für das Berg-, Hütten und Salinenwesen*, vol. lvi. p. 178.

‡‡ *Engineering and Mining Journal*, vol. lxxxv. pp. 111-112.

§§ *Zeitschrift für Schiess- und Sprengstoffwesen*, 1907, pp. 272, 291.

K. Scholze * gives the results of tests of various explosives.

¶ J. Grundy † deals with the manufacture of native blasting powders in India, and generally with their application and with the cause and prevention of premature explosions. It is suggested that the burning temperature of the sulphur in the powder may be insufficient to cause its explosion unless it first ignites paper.

Some modern methods and apparatus for the testing of explosives are described by S. Nauckhoff. ‡

Compressed Air in Mines.—P. Bernstein § describes the hydraulic air compression plant at the Clausthal mines.

Rock-drills.—J. T. Glidden || advocates the employment of air hammer drills in all mines where compressed air is available, as they are very simple in construction, and there is no valve mechanism to get out of order.

E. M. Weston ¶ discusses the development of the small pneumatic hammer drill. He gives sections of the Leyner Rock Terrier drill, the Water Leyner rock-drill, the Murphy drill, and the Gordon drill. The first and third of these are valveless with the differential piston or hammer itself acting as the valve. The large Leyner machine is worked by a piston valve, and the Gordon drill by a valve at right angles to the piston. Drawings are also given of the Konomax drill and of the Temple-Ingersoll electric air drill.

T. B. Burnite ** discusses the development of the air-hammer rock-drill.

Drills for stoping are described by A. Del Mar. ††

Details of the trial of stope-drills at Johannesburg on December 31, 1907, have been published. ‡‡

Experience with hammer rock-drills in Swedish mines is recorded by E. Mossberg. §§

W. L. Saunders |||| gives an illustrated description of a new form of electric air-drill, in which, despite the difficulties hitherto encountered in solving the problem of the direct application of electric current in rock drilling.

The Jeffrey electric drill is described and illustrated. ¶¶¶ It has been designed for heavier duties than has so far been found possible with

* *Oesterreichische Zeitschrift für Berg- und Hüttenwesen*, vol. lv. pp. 622-626.

† *Transactions of the Mining and Geological Institute of India*, vol. ii. pp. 105-126.

‡ *Teknisk Tidskrift*, vol. xxxviii. pp. 31-34 and 45-46.

§ *Glückauf*, vol. xlv. p. 375.

|| *Engineering and Mining Journal*, vol. lxxxiv. p. 818.

¶ Paper read before the Chemical, Metallurgical, and Mining Society of South Africa; *Mining Journal*, vol. lxxxiii. pp. 70, 103, 129-130.

** *Mining World*, vol. xxviii. p. 97.

†† *Mining and Scientific Press*, February 1, 1908.

‡‡ *Engineer*, vol. cv. pp. 135-138.

§§ *Blad för Bergshantningens Vänner*, vol. xii. pp. 23-31.

¶¶ *Bi-Monthly Bulletin of the American Institute of Mining Engineers*, 1907, pp. 991-1000.

¶¶¶ *Iron and Coal Trades Review*, vol. lxxvi. pp. 47-48.

rotary drills, the design embracing several features of novelty. The armature spindle through which the drill feed-screw passes is hollow. By this means a well-balanced drill is provided, as hitherto the motor has been necessarily above, below, or on one side of the feed-screw.

An electric furnace for tempering drills after sharpening has recently been installed by the Allgemeine Elektrizitäts Gesellschaft in the mines in South Africa. Should it prove successful, the direct economic results from its general use will be considerable, as it will counteract the difficulties of overheating and burning the steel, and obviate the expense, labour, and delay of carrying the drills to the surface every time they require sharpening. The introduction of this new furnace will admit of the best steels being used, and should cause fewer complaints of the rapid blunting of drills.*

Methods of Working.—Recent progress in the working of the iron ore deposits of Lorraine is described.†

The methods employed in mining iron ore on the Menominee are described ‡ and illustrated. Steel is largely substituted for wood in the construction of shaft-houses, while the low grade ore is largely taken out by the caving method. Under the cave all ore is removed except the pillars, sand and surface being taken out for supporting the roof of worked out rooms elsewhere.

R. Richter§ describes American steam-shovels, which are mostly of the A-frame type. The output is increased as far as possible by driving the different motions by separate steam-engines. Steam-shovels are constructed with considerable outputs and weighing up to 100 tons. There are two distinct types of steam-shovel: the turntable type, which is generally employed for lighter shovels, and the A-frame type for large outputs. The steam-shovel is employed for excavating forward, backward, and sideways. Sideways excavating is generally resorted to.

A-Frame Shovels.—The 64-ton shovel is generally employed at the present time in the United States. A steam-shovel built by the Marion Steam Shovel Company, having the following dimensions, is described in detail: Contents of bucket, 67 cubic feet; minimum output in heavy ground, two full buckets in a minute; greatest tensile force in the pulley-blocks, 25 tons; height of stroke of the bucket above rails, 14 feet 9 inches; width of cutting, 55 feet; reach of arm, 200°; weight of steam-shovel, 64 tons; highest point of arm above rails, 25 feet; highest point of A-frame above rails, 19 feet 4½ inches; length of carriage, 34 feet 9 inches; width of carriage, 9 feet 10 inches.

Turntable Shovel.—These resemble in outward design the travelling steam-crane. The author describes several types of English and American turntable steam-shovels. The steam-shovel can dig into any material that can be excavated by bucket excavators, and can

* *South African Mines; Electrician*, vol. ix. p. 158.

† *Times Engineering Supplement*, January 22, 1908, p. 6.

‡ *Iron Trade Review*, vol. xii. pp. 659-662.

§ *Zeitschrift des Vereines deutscher Ingenieure*, vol. li. pp. 1685-1695.

deal with measures such as deposits of shale, limestone, and brown-coal. When the ground is deeply frozen a steam-shovel can work without difficulty, but a bucket excavator has to cease working. Further advantages of the steam-shovel, as compared with the bucket excavator, are mentioned.

Winding.—The economy of coal in winding in ore mines is discussed by Karl Rietkötter.* The desirability of using double-deck cages in the Siegen iron ore mines is strongly urged.

The dense-air system, or, as it is perhaps known to some engineers, the return-flow system of compressed-air power transmission, is probably more familiar in South Africa than it is in Great Britain, and illustrations have been published † of a powerful engine working on this system.

The relative advantages of long-range and short-range trip gears for winding-engines are discussed by R. H. Collingham.‡

T. H. Ward§ describes a method for the internal examination of wire ropes after they have been in use. The rope is held by clamp a short distance apart and partly untwisted, so that the condition of the internal wires may be inspected for corrosion. Much discussion ensued.

Electricity in Iron Ore Mines.—J. B. van Brussell || describes the electrical hoisting equipment at the Grängesberg iron mines, Sweden. Many thousands of tons have been mined by surface workings, but shafts have now been sunk at the foot of the hill to a depth of 600 feet, and an ultimate depth of 1800 feet is expected to be reached. Winding is only carried out during one shift of eight hours, the machinery being capable of raising the whole output of twenty-four hours (1200 tons) during this period. The great distance—110 yards—between the shaft and the engine-house, and the height of the pit-head frame—130 feet—are noteworthy features of the plant.

Mine Drainage.—Various types of electrically-driven mine pumps are described by John Tuneld.¶

The new electrical pumping installation at the Lindal Moor iron mines, near Ulverston, is described ** and illustrated. The mines have had to contend with inrushes of water in overwhelming quantities. At several of the Lindal pits pumping operations ceased in December 1903, owing to breakdowns, and owing to the pumping plant then existing being insufficient to cope with the inrush of water.

* *Glückauf*, vol. xliii. p. 1565.

† *Engineering*, vol. lxxxv. pp. 334-335.

‡ *Engineer*, vol. civ. pp. 460-461.

§ *Transactions of the Mining and Geological Institute of India*, vol. i. pp. 173-191, 235-238.

|| *Engineering and Mining Journal*, vol. lxxxiv. pp. 1162-1165.

¶ *Blad för Bergshantveringens Vänner*, vol. xii. pp. 163-176.

** *Iron and Coal Trades Review*, vol. lxxv. pp. 1381-1383; *Engineering*, vol. lxxxiv. p. 490.

The four pits so affected are connected together underground either artificially or by natural drainage. At the time the pumping operations ceased the maximum inrush of water reached nearly 7000 gallons per minute, though the normal dry-weather flow only amounted to 4000 gallons per minute. The total quantity of water with which the whole plant will be able to deal is about 15,000 gallons per minute, this being reduced to 8000 gallons per minute as the pumps reach the lower levels. The motors are of very special design for working under the abnormal conditions, and are constructed with particularly narrow dimensions to admit of their passing down the narrow pumping ways available. The current is generated by three steam turbo-generators of the horizontal type. Each set is capable of a continuous output of 1140 electrical horse-power, 3300 volts, 50 cycles per second, when running at 3000 revolutions per minute, and supplied with steam having a pressure of 200 lbs. per square inch at the stop valve, superheated to a temperature of about 600° F.

The Lighting of Mines.—The various methods of lighting adopted in Swedish mines are discussed by N. Hedberg.* The acetylene lamp gives the most powerful light, and is by far the cheapest per candle-power-hour.

Mine Surveying.—C. E. Morrison † gives a general account of mine surveying, with special reference to shaft surveying.

G. Plotenyi ‡ gives some notes on mine surveying, and points out the advantages of Gurden's traverse tables.

E. Hammer § describes the measurement of base-line with rods, wires, and bands of invar (nickel-steel alloy with 36 per cent. of nickel).

M. Villiers Stuart || describes a method for checking the angular work of a traverse by azimuths.

The instruction in mine surveying at Austrian mining schools is discussed by L. Haberer.¶

The application of the camera as an adjunct to topographical mapping began practically with its invention, and it has been employed with varying success since that time. An interesting development is described by C. W. Wright,** who has successfully employed in the field a panoramic camera taking a 5-inch by 12-inch view, including an angle of 140°. The plotting of a map from the views taken by the phototheodolite is a tedious process, and the office work is many times greater than that required for the same amount of mapping by the panoramic camera.

* *Blad för Bergshanteringens Vänner*, vol. xii. pp. 144-162.

† *School of Mines Quarterly*, vol. xxix. pp. 34-45.

‡ *Banyassati es Kohassati Lapok*, vol. xl. p. 542.

§ *Zeitschrift für Vermessungswesen*, vol. xxxvi. pp. 425-440, 643-645, 905-907.

|| *Cairo Scientific Journal*, vol. ii. pp. 27-28.

¶ *Oesterreichische Zeitschrift für Berg- und Hüttenwesen*, vol. lv. p. 320.

** *Bi-Monthly Bulletin of the American Institute of Mining Engineers*, 1908, pp. 101-116.

The advantages which have accrued to the mineral industries of the United States from the work of the United States Geological Survey were summed up in an address to the American Mining Congress by the director of the survey, G. O. Smith.*

Problems in Metal-mining.—The sixteenth "James Forrest" lecture was delivered before the members of the Institution of Civil Engineers by Henry Louis,† the subject being "Some Unsolved Problems in Metal-mining." The whole field of metal-mining was reviewed, and the author showed that coal-mining was nowadays less dangerous to life than metal-mining, though but a short while ago the reverse was the case. He said that the great improvement as regarded safety to workers which had taken place in coal-mining within recent years was due, to a very large extent, to the Coal Mines Regulation Act, which requires a certificate of competency before a man is allowed to take charge of a colliery, whilst a man is legally entitled to manage a metal-mine whatever his qualifications or lack of qualifications may be. He held, he said, that metal-mining should be governed by the same law as is coal-mining, and he believed that the solution of the problem of how to make metal-mining a safer occupation than it is to-day would be found in a sounder and more rational system of technical training for the miner.

Economics of Mining.—D. E. Woodbridge ‡ deals with iron mine assessments in the state of Minnesota, in which there have been recently made some remarkable changes in the taxable valuation of iron mines, the result of official action which is characterised as precipitate and unjust.

Iron Ore Transport.—A. Pietrkowski § describes the Oettingen-Differdingen wire ropeway of the German Luxemburg Mining and Ironworks Company. The line is 12,780 metres long, and the difference in level between the two terminal points is 15 metres. The line was started on October 5, 1906, and during the first three months the working costs were less than 2½d. per ton.

An article has been published || on progress in the construction of great wire ropeways, special reference being made to the two ropeways built by Pohlig of Cologne for the Aumetz-Friede and Differdingen ironworks, and to a ropeway, 33 kilometres long, at the Upulungos mines in the Argentine Republic, as well as to one 87 kilometres long in Turkestan.

M. Freyberg ¶ discusses the working of aerial ropeways.

Handling Iron Ore.—The question of handling materials in industrial plants is one continually presenting itself to owners and

* *Engineering and Mining Journal*, vol. lxxxiv. pp. 1019-1020.

† *Engineer*, vol. cv. p. 448; *Mining Journal*, vol. lxxxiii. p. 528.

‡ *Engineering and Mining Journal*, vol. lxxxiv. p. 967.

§ *Glückauf*, vol. xliii. pp. 1671-1677.

|| *Ibid.*, vol. xliv. pp. 271-272. ¶ *Montan Zeitung*, vol. xv. pp. 122-124, 139-143.

engineers for proper solution, and some striking illustrations, showing the remarkable progress recently made in America in economical material-handling equipments, are given by Werner Boecklin.* The depreciation of such equipments is necessarily high, but in the majority of cases an increase in the first cost, which will materially decrease this charge, is warranted. T. Kennard Thomson † describes the construction of hoisting machinery for the handling of materials. He shows that here, as elsewhere in the domain of modern enterprise, economy in unit costs and maximum of output can be secured only where intelligent use is made of the mechanical facilities afforded for the handling of material.

The ore-handling appliances at the plant of the South Bethlehem Steel Company, Pennsylvania, are described and illustrated.‡ At the furnaces there are four batteries of Hoover and Mason pockets, each battery having a capacity of 1000 tons of ore, 375 tons of limestone, and 500 tons of coke. To provide against the freezing of the ore in winter, chambers are provided on the ore side, outside the sloping bin bottom, and a fan-blower draws hot waste gases from an adjoining furnace and forces them through the chambers.

A description and plans of the new steel ore dock at Two Harbours, Minnesota, have appeared.§ The new docks will add about 2,000,000 tons to the annual shipping capacity of Two Harbours.

History of Mining.—In a paper on the psychology of mining, Samuel Rakoczy || gives illustrations of some interesting antiquities connected with the Schemnitz mines.

G. Plotenyi ¶ gives some illustrations of old Roman workings at Verespatak. He shows the style of timbering and of mine ladder used.

III.—MECHANICAL PREPARATION.

Iron Ore Dressing.—N. V. Hansell ** describes the concentration of iron ore with special reference to American methods at Port Henry, Hibernia, and Lebanon.

A method of removing broken stems from stamp heads is described.†† The pressure of a 140-ton hydraulic press was insufficient to press out the stem. The application of a blow-lamp so as to expand the metal of the head resulted in allowing the press to squeeze out the broken ends with only half the pressure which had at first proved unsuccessful.

* *Engineering Magazine*, vol. xxxiv. pp. 956-964.

† *Ibid.*, pp. 1005-1028.

‡ *Iron Age*, vol. lxxx. pp. 1371-1375.

§ *Iron Trade Review*, vol. xli. pp. 865-868.

|| *Banyassati es Kohassati Lapok*, vol. xl. pp. 519-538.

¶ *Ibid.*, vol. xli. pp. 173-175.

** *Bihang till Jernkontorets Annaler*, 1908, pp. 1-18, 43-65.

†† *Journal of the Chemical, Metallurgical, and Mining Society of South Africa; Engineer*, vol. cv. p. 89.

Magnetic Separators.—P. McN. Bennie * gives an account of progress in magnetic separation by the Gröndal process, and discusses its possible bearing on the utilisation of certain Canadian iron ores.

E. Åkerman † describes the application of the Gröndal briquetting process to Spanish iron ores.

The magnetic concentration and briquetting of iron ores by the Gröndal process is described by A. S. Lewitinski ‡ and W. A. Petroff.

J. Bartsch § describes the magnetic concentration plant at the Brüderbund iron mine at Eisern. The plant, built by the Humboldt Company, treats 60 tons daily, and requires 45 horse-power. The cost of concentration is ls. 11d. per ton.

The concentration of magnetic iron ore at the Lyon Mountain mines, New York, is described. ||

Briquetting Iron Ore.—Some interesting details of processes now employed for the briquetting of ores are given from the report of a Commission ¶ appointed to examine into the question. The following processes are described:—

1. Schumacher's method. Fine lime and finely-ground quartz are mixed with the ore, which is then treated with steam which hardens the briquettes. Flue-dust and all fine ores can be treated by this process. Plants are working at Königshütte, and at the Friedrich - Alfred - Hütte at Rheinhausen. The cost per ton for briquetting purple ore, fine Gellivare ore, and flue-dust are given.

2. The method in use at the Ilseder Hütte is of rather local interest owing to the works smelting their own ores from the neighbouring mines of Bülten-Adenstedt and Lengede-Bodenstedt. The lumpy ore goes direct to the blast-furnaces, whilst the fine calcareous stone is washed and partially dried in a cylindrical drum. The ore is pressed warm at a pressure of about 300 kilogrammes; about eighteen briquettes are made per minute, falling on a belt which carries them direct to the trucks for transport.

3. The method employed by the German Briquetting Company at Altenkirchen-Westerwald is described and illustrated. A binding material is added to the fine ore, but the composition of this is not given. The bricks are weathered for a few weeks, and are then hard enough for use.

4. The process patented in Germany and abroad by the Scoria Company of Dortmund is described. The binding material employed is granulated blast-furnace slag, which is mixed with the fine ore or flue-dust, and afterwards treated with exhaust steam, which confers upon the slag binding properties similar to Portland cement.

5. The Raduschewitsch process used at Olonetz is shortly described. This is a sintering process without previous briquetting.

* *Journal of the Canadian Mining Institute*, vol. x. pp. 261-273.

† *Revista Minera*, vol. lix. pp. 15-16. ‡ *Gorni Journal*, 1907, pp. 337-348.

§ *Glückauf*, vol. xlix. p. 457.

|| *Electrochemical and Metallurgical Industry*, vol. v. p. 473.

¶ *Stahl und Eisen*, vol. xxviii. pp. 321-325.

A description has been published of the method of briquetting iron ore by the Gröndal system at the Alquife mines in Granada, Spain.*

The preparation of iron ore briquettes from titaniferous sand is described by J. H. L. Vogt.†

IV.—METALLURGICAL PREPARATION.

Calcining Kilns.—F. G. Stridsberg † gives drawings of a rotary kiln for roasting pulverulent iron ores. It is $63\frac{1}{2}$ feet in length and 39 inches in diameter, and is heated with blast-furnace gas. It rotates three times a minute, and is driven by an eleven horse-power dynamo. It treats 30 to 35 tons a day.

M. Fröding § gives drawings of a suggested design for a kiln for roasting pulverulent ores.

* *Revista Minera*, vol. lviii. pp. 475-476, 491-493.

† *Teknisk Ugeblad*, 1908, pp. 4-8.

‡ *Blad för Bergshanteringens Vänner*, vol. xii. pp. 19-23.

§ *Ibid.*, pp. 113-115.

REFRACTORY MATERIALS.

Physico-Chemical Investigation of Refractory Materials.—T. Holgate * shows how the law of depression of the freezing point, to the enunciation of which both Raoult and Van't Hoff contributed, has helped to elucidate the complex question of the nature of materials in their refractoriness to heat.

M. Simonis † has investigated the melting point of chrome iron ore when mixed with small quantities of pure kaolin, the material being compared with Seger cones.

Fireclays.—The utilisation of fireclays is discussed by E. P. Page ‡ and W. J. Rees.

The artificial alteration of the degree of plasticity of clays is described by D. P. Rohland.§

F. Freise || describes the clays of the Westerwald. Fireclay of excellent quality is mined.

R. C. Purdy ¶ and F. W. De Wolf give the results of a preliminary investigation of Illinois fireclays.

Silica Sand.—B. S. Randolph ** gives an account of the quarries and washeries of the West Virginia and Pennsylvania Sand Company, near Berkeley Springs. The chief sources of the supply of silica sand in the United States comes from three geological horizons, the St. Peter sandstone in the Mississippi valley, which comes from the Cambrian; the Oriskany in Pennsylvania, West Virginia, and Maryland, which is Devonian; and the Cheshire quartzite from the Berkshire hills of Massachusetts, which, like the St. Peter sandstone, is of Cambrian origin. The methods employed in preparing the Oriskany sandstone, which is quarried at the works mentioned, are described. Selected quarry samples average 99 per cent. of silica.

Manufacture of Firebricks.—The Robinson Clay Products Company has built a new plant for the manufacture of silica brick for

* *Engineering*, vol. lxxxv. pp. 235-238.

† *Stahl und Eisen*, vol. xxviii. pp. 334-335.

‡ *Journal of the Society of Chemical Industry*, vol. xxvii. pp. 99-102.

§ *Die Chemische Industrie*, 1907, pp. 637-639.

|| *Zeitschrift für praktische Geologie*, vol. xvi. pp. 162-165.

¶ *Illinois State Geological Survey, Bulletin No. 4*, pp. 129-175.

** *Engineering and Mining Journal*, vol. lxxxiv. pp. 1211-1212.

lining open-hearth and other furnaces. The clay contains 97·2 per cent. of silica, 1·4 per cent. of alumina, 1 per cent. of oxide of iron, and a trace of lime. Some lime is added in grinding, to act as a binder. The material is first ground in two 9 feet wet grinding pans, and then delivered by shoots to the moulding floor or to a belt conveyor, which carries it to the dry floor in an adjacent building, where bricks of special shapes are made. In making the regular brick, a mould for ten bricks is set on a bottom board and clay shovelled in, and rammed with a pneumatic rammer. The mould is then removed, and the bottom boards are placed on steel trucks which are run into tunnels under the dry floor. There are twelve tunnels, each holding fourteen trucks, and each truck carries 480 bricks. The trucks take about three days to pass through the tunnel, and are then left in the cooling room. When cool enough to be handled, the trucks are run into the kilns, where the bricks are stacked and subjected to high temperature for about nine days. There are six kilns, 55 feet by 30 feet, each holding 100,000 bricks; each has six double furnaces, which may be fired with coal or gas. After the nine days' burning the fires are drawn and the kiln cooled; this is effected by putting up a connection to the flue of a 12-foot exhaust fan, which draws air through the kiln. The cooling takes about seven days. Bricks of special shape are moulded by hand at benches on an upper floor, and laid on the floor for the preliminary drying. This plant can produce about 700,000 bricks per month.*

The manufacture of firebricks is described by F. Janitz.†

The heat conductivity of furnace building materials is discussed by H. Mehner.‡

H. Steger§ has given an account of the non-conducting materials used for covering purposes in the iron industry. The article discusses the best material to be used for different purposes, with especial reference to porosity.

Graphite.—The occurrence of graphite in the Dunkelstein forest, Austria, is described by H. Tertsch.||

H. P. H. Brumell¶ describes the occurrence of graphite in Canada, where an industry in this mineral is being developed that promises, in the near future, to be of no small importance.

H. H. Hayden,** in a description of the geology of Central Thibet, describes the graphite used in the local arsenal for the manufacture of crucibles. It is said to come from the Kong valley between Yam-drok Tso and Shigatse. Rumours of the occurrence of coal in the Nyang Chu valley and at Lhasa proved to be groundless.

* *Engineer*, vol. civ. p. 502.

† *Tonindustrie Zeitung*, vol. xxxii. pp. 168-170.

‡ *Chemiker Zeitung*, vol. xxxi. p. 1230.

§ *Stahl und Eisen*, vol. xxvii. pp. 1697-1699.

|| *Mitteilungen der mineralogischen Gesellschaft*, Vienna, 1907, pp. 59-60.

¶ *Journal of the Canadian Mining Institute*, vol. x. pp. 85-104.

** "The Geology of the Provinces of Tsang and Ü." Calcutta: Geological Survey of India.

H. L. Dejust * describes some oxidising and decolourising properties of graphite.

H. Le Chatelier † and S. Wologdine have redetermined the density of graphite from eight different sources using a mixture of tetrabromoethane and ethyl ether in which the graphite floated. After impurities and air in the pores had been carefully removed, the graphite gave a density of 2.255.

C. H. Benjamin ‡ describes a series of experiments with graphite lubrication, and gives the results of tests with several lubricants.

E. G. Acheson § describes the manufacture of graphite from anthracite coal, and experiments made with deflocculated graphite suspended in oil as a lubricant.

Magnesite.—B. A. Wendeborn || gives an account of the applications and value of magnesite.

In a memoir on the genesis of the Alpine talc deposits, K. A. Redlich ¶ and F. Cornu describe the magnesite-talc deposit of the Häuselberg. The massive magnesite contains 39.17 to 43.84 per cent. of magnesia.

With reference to the recent discovery of a deposit of magnesite of considerable extent at Fifield, New South Wales, by J. B. Jacquet, E. Kilburn Scott, ** who is conducting a series of tests with the product, states that the Fifield deposit is unique in its remarkable purity, and especially in that lime is absent. All other deposits, including those of New Caledonia, the United States, and the large deposits at Eubœa, have much lime present. For many years experts have been trying to meet the great call for a magnesite brick to withstand higher temperatures than the ordinary silica firebrick. One difficulty in the way has apparently been due to impurities—especially lime—in the raw material.

A. L. Hall †† describes the occurrence of magnesite in the Transvaal in veins in serpentine.

It is stated that most of the magnesite in California comes from the deposits in Tulare county, near Porterville, where it is mined very cheaply by quarrying. Calcining furnaces have been built at that point. The consumption of magnesite in California is confined to the Pacific coast, as the cost of transport eastwards is prohibitive. There are many known deposits of the mineral, but, generally speaking, only those are utilised which are near the railway line, where cheap transportation may be obtained. C. G. Yale †† describes the magnesite

* *Comptes Rendus*, vol. cxliv. p. 1264.

† *Ibid.*, vol. cxlvi. pp. 49-53.

‡ *American Machinist*, vol. xxx. pp. 934-937.

§ Paper read before the American Electro-chemical Society; *American Machinist*, vol. xxx., Part II. pp. 788-789.

|| *Berg- und Hüttenmännische Rundschau*, vol. iv. pp. 98-99.

¶ *Zeitschrift für praktische Geologie*, vol. xvi. pp. 145-152.

** *Board of Trade Journal*, vol. lix. p. 326.

†† *Report of the Transvaal Geological Survey*, pp. 125-132.

‡‡ *Engineering and Mining Journal*, vol. lxxxv. p. 110.

deposits of California, which are the only deposits commercially utilised in the United States. The annual output is about 8000 tons.

Dolomite.—F. W. Pfaff * gives the results of an investigation of the origin of dolomite, citing incidentally a large number of analyses. True dolomite is considered by the author to be a lime-magnesia carbonate rock containing more than 11 per cent. of magnesium carbonate.

G. C. Hoffmann † gives analyses of nine limestones and dolomites from various localities in Canada.

* *Neues Jahrbuch für Mineralogie ; Beilage*, vol. xxiii, pp. 529-580.

† *Geological Survey of Canada, Bulletin No. 958*, pp. 36-42.

FUEL.

CONTENTS.

	PAGE		PAGE
I. Calorific Value	265	VI. Natural Gas	284
II. Coal	268	VII. Artificial Gas	286
III. Charcoal	271	VIII. Coal-Mining	289
IV. Coke	272	IX. Coal-Washing	305
V. Liquid Fuel	276		

I.—CALORIFIC VALUE.

Calorimetry.—W. H. Rawles * describes a calorimeter for liquid fuels, a modification of Darling's apparatus.

H. N. Potter † describes a modified form of the Berthelot-Atwater bomb calorimeter. On burning substances which produce solid oxides in oxygen under pressure in the ordinary bomb calorimeter, the oxide produced forms a coating around the test sample, and the inner core remains unburned. The author has modified the Atwater calorimeter by providing a thin inner lining of a chemically inert material fitting closely into the outer steel bomb. The lining of the cover is made removable, and the electrical contacts and crucible holder are attached to this cover. The removable bomb lining and its cover are charged with the sample, and then weighed before and after the combustion. From the gain in weight, which represents the combined oxygen, the weight of substance burned can be calculated. The calorific value of silicon was found to be 7594.8 calories per gramme.

C. Féry ‡ describes a calorimeter for the determination of the calorific power of liquid and gaseous fuels. The combustion is effected at the base of a glass chimney, the top of which supports a nickel plate pierced with a number of holes. The air necessary for combustion passes down a similar chimney, which is connected at its base with the former. The two junctions of a constantan-copper thermo-circuit are placed at the tops of the chimneys. The electro-motive force in the circuit is exactly proportional to the calorific

* *Journal of the Society of Chemical Industry*, vol. xxvi. pp. 665-667.

† *Transactions of the American Electrochemical Society*, vol. xi. pp. 259-263.

‡ *Journal de physique*, vol. vi. pp. 886-889.

power of the combustible and to the volume of it consumed in unit time.

W. P. White* describes an arrangement by which everything within the calorimeter case is either at the temperature of the calorimeter water or at that of the jacket water. The difference between the two temperatures is measured, and the temperatures of lagging of the metal parts are eliminated. Several measurements are stated to show that the average variation is only two parts in 10,000.

C. C. Thomas† gives an illustrated description of the Thomas steam calorimeter designed for determining the quality of steam at the different phases of steam-turbines. It can be used with steam of any degree of wetness, and of any temperature and pressure above that in the condenser. The instrument is based on the fact that, if wet steam be passed through a calorimeter electrically heated, and then through a glass tube containing a thermometer, no rise in temperature of the latter will be apparent until the steam has been thoroughly dried by the electric heat. The quality of steam can be calculated from the amount of heat required to dry the steam, from the heat of vaporisation of dry steam, and the weight of steam passing through the calorimeter during a definite period of time.

A. Adam‡ describes a device for the continuous determination of the calorific value of gases.

M. Stoecker§ and W. Rothenbach describe a calorimeter for determining the calorific value of small quantities of gas.

E. U. G. Ernst|| describes the determination of the calorific value of fuels from their elementary composition.

H. Pleyer¶ describes an explosion of a calorimetric bomb for which he cannot offer an explanation.

Recent researches on the calorific power of fuels are summarised by W. Bertelsmann.**

Pyrometry.—W. P. White †† discusses the use of a thermo-element with a potentiometer as the most accurate measuring apparatus for temperatures up to 1600°. Rapidity is secured by an arrangement of the galvanometer, by the use of switches to exchange thermo-elements, by the adjustment of zero, and by relying upon the galvanometer for as much of the reading as possible. Leakage is reduced by equipotential shields. A slide-wire potentiometer is unsuited for rapid work.

I. W. Chubb ††† describes an indicating instrument by which the correct hardening temperature for small tools of carbon steel is obtained automatically whatever the composition of the steel under

* *Physical Review*, vol. xxv. pp. 137-138.

† *Power*, vol. xxvii. pp. 790-794.

‡ *Revue de Métallurgie*, vol. v. pp. 34-37; *Engineering Magazine*, vol. xxxv. pp. 111-112.

§ *Journal für Gasbeleuchtung*, vol. li. pp. 121-124.

|| *Ingeniören*, Copenhagen, 1908, pp. 23-27.

¶ *Chemiker Zeitung*, vol. xxxi. p. 159.

** *Ibid.*, vol. xxxii. pp. 513-514.

†† *Physical Review*, vol. xxv. pp. 334-352.

††† *American Machinist*, vol. xxx., Part II. pp. 723-726.

treatment. The device depends upon the recognition of the facts that the temperature at which a carbon steel should be quenched for hardening is that at which recalescence occurs, and that at this point also the steel ceases to be magnetic. The use of the indicator applied to a muffle furnace is also described.

E. R. Markham * deals with the conditions under which the pyrometer may be used to advantage, and gives explanations of the causes of unsatisfactory experiences in the heat treatment of steel.

A recording pyrometer invented by W. H. Bristol † is described and illustrated. It resembles a Weston voltmeter, and automatically records the temperature by means of a patented smoked chart. The thermo-couple is placed at the point the temperature of which is to be measured; the indicating instrument being placed at any place convenient to the operator, and the recorder placed vertically at a distance from the source of temperature, a duplex cable connecting the indicator or recorder to the fire end and the switch-box.

W. Woltmann and Wl. Wostowitsch ‡ have made various measurements of temperature in blast-furnace practice with the aid of the Wanner pyrometer. They conclude that only a still glow can be measured: temperatures in the interior of a glowing furnace, or glowing objects in the solid or fluid state. The various temperatures are, however, governed by various properties of the heated bodies (specific heat, conductivity, radiation). Thereby the application of the pyrometer for exact measurements in blast-furnace practice is limited. Slag, metal, and brick flowing in the form of a stream also give in the pyrometer a picture of a flowing band, the comparison of which with the full semicircle from the electric lamp is difficult and inexact.

J. Becker § describes a Le Chatelier pyrometer mounted in quartz glass.

Chauvin || and Arnoux deal generally with thermo-electric pyrometers.

The Chauvin and Arnoux thermo-electric pyrometer is described by M. Aliamet. ¶

Fuel Value of Coal.—A. Bement ** gives a large number of analyses of American coals, with details of their calorific value.

A. Wiede †† gives the results of experiments made to utilise as fuel the coal-dust produced in mining operations.

Steam-boiler Heating.—L. P. Breckenridge †† reviews the United States Geological Survey fuel tests under steam-boilers.

* *American Machinist*, vol. xxx., Part II, pp. 712-713.

† *Iron Trade Review*, vol. xii, pp. 664-665.

‡ *Metallurgie*, vol. iv, pp. 799-800.

§ *Journal für Gasbeleuchtung*, vol. i, p. 895.

|| *Bulletin de la Société d'Encouragement*, vol. cix, pp. 1171-1178.

¶ *Electricien*, January 25, 1908.

** *Journal of the Society of Chemical Industry*, vol. xxvi, pp. 670-672.

†† *Jahrbuch für das Berg- und Hüttenwesen im Königreiche Sachsen*, 1907, pp. 27-34.

‡‡ *Journal of the Western Society of Engineers*, vol. xii, pp. 286-324.

Dealing with steam production from the cheaper grades of anthracite, W. D. Ennis* discusses the mechanical problems of air supply, grate and heating surfaces, &c., which affect the economical use of anthracite in the boiler furnace. He also describes the leading types of drying, grinding, and conveying devices applicable to the economical use of pulverised coal as a boiler fuel. He illustrates methods and apparatus for firing, and gives details of the cost of installation and operation. It is pointed out that the commercial value of pulverised coal is not limited to its use in the boiler furnace, but that it is destined to have a widespread application in the metallurgical industries, where its cheapness will enable it to replace oil and gas for the firing of certain classes of furnaces. In conclusion, the efficiency in the burning of bituminous coal under a steam-boiler is discussed.

In a lecture on the sources of economy in power production delivered before the National Association of Colliery Managers, W. H. Patchell † dealt with the feed-water, feed-heaters, and other matters connected with boilers.

Smoke Abatement.—L. P. Breckenridge ‡ discusses the burning of Illinois coal without smoke. The fundamental principles that apply to smokeless furnace construction and working are enumerated, and, by means of units in actual operation, several ways are indicated in which these principles have been satisfactorily applied.

Papers on smoke abatement have been written by H. Ost § and by J. H. Mehrrens. ||

As a contribution to the subject of smoke abatement, J. H. Mehrrens ¶ gives a historical account of the methods of firing adopted from 1770 to 1870.

II.—COAL.

Chemistry of Coal.—P. P. Bedson ** gives a summary of the work of various authors on the action of solvents on different classes of coals and on the proximate analysis of coal, and a preliminary notice of a study of coals from the Busty seam, Boitley, County Durham.

F. F. Grout †† states that the percentage of hydrogen in pure coal is 5.38, with an average error of 0.16 per cent. The estimation of the total carbon yields sufficient data for the calculation of the approximate analysis. The calorific value can be calculated by aid of Dulong's

* *Engineering Magazine*, vol. xxxiv. pp. 294-302, 463-478, 577-589.

† *Iron and Coal Trades Review*, vol. lxxvi. pp. 918-921.

‡ *University of Illinois, Bulletin* No. 15.

§ *Zeitschrift für Angewandte Chemie*, vol. xxi. pp. 1689-1698.

|| *Glaser's Annalen*, vol. lxi. pp. 176-182, 205-210.

¶ *Zeitschrift für Dampfkessel und Maschinenbetrieb*, 1907, pp. 537-539.

** *Journal of the Society of Chemical Industry*, vol. xxvii. pp. 147-150.

†† *Journal of the American Chemical Society*, vol. xxix. pp. 1497-1499.

formula. Recent experiments indicate that Dulong's formula gives low results, and before calculating the calorific value 0.17 per cent. should be added to the figures obtained for the available hydrogen. In cases where no analysis of the coal can be carried out, this estimated analysis gives the best foundation for calculating the heat value.

W. F. Wheeler * endeavours to establish a means for comparing the value of bituminous coal by using pure coal as a basis, taking, as a definition of pure coal, a coal that would be ash- and moisture-free. The exclusion of these two variables does not, however, justify ash- and moisture-free coal being regarded as pure coal when it contains a widely varying amount of sulphur, which is no more a part of it than the ash and the moisture. An ideal pure coal should include the carbon, hydrogen, oxygen, and nitrogen, and also that part of the sulphur that is not combined with the ash. Tables are given showing that, when delicate distinctions are to be made, pure coal will furnish a better basis for comparison than any basis now in use, provided that correction be made for the sulphur and chemically combined water in the ash. The calorific value of the sulphur-free coal may prove to be one of the most useful factors in classifying coals.

L. Vignon † gives details of an investigation made to determine the relation between the composition of coal and the amounts of carbon monoxide and dioxide contained in the gas distilled from it.

Coal in the Midlands.—P. F. Kendall ‡ discusses the geology of South Derbyshire and Leicestershire with special reference to the coal measures. The South Derbyshire and Leicestershire coalfield has not been properly explored. There are peculiar circumstances connected with it which have prevented its exploration, but the neighbouring fields of Nottinghamshire and North and South Staffordshire have been thoroughly explored—North Staffordshire particularly. The two main theories as to the conditions under which the deposits of vegetation, which subsequently become coal, were accumulated are discussed. These are the Drift theory, and the theory which ascribes to the coal deposits the accumulative action of successive forest growths which have perished *in situ* and become coal.

Coal in Lancashire.—Joseph Dickinson § gives a section of a borehole at Moss Lane, Whitefield. The section gives valuable information regarding the stratigraphy of the Lancashire coalfield.

Coal in Ireland.—Shafts sunk recently at Rossberg, near Dunganon, County Tyrone, have resulted in the discovery of four workable seams of coal in the vicinity of old workings. The coal is of a

* *Bi-Monthly Bulletin of the American Institute of Mining Engineers*, 1908, pp. 49-60.

† *Bulletin de la Société Chimique*, vol. iii. pp. 109-114.

‡ Paper read before the National Association of Colliery Managers; *Iron and Coal Trades Review*, vol. lxxv. pp. 2328-2329.

§ *Transactions of the Institution of Mining Engineers*, vol. xxxiv. pp. 349-350.

bituminous nature, and the area of the coalfield has been roughly estimated at about 24 acres, at 3000 tons to the acre in a 30-inch seam. It is believed that coal will be found all round the district outside the faults of the Drumglass, Denaghadone, Congo, and Kingariffe workings.*

Coal in Austria.—Several borings for new colliery shafts are in progress in Austria. At Hruschau and Wirbitz borings have been put down for coal to a depth of 500 yards; and at Ober-Suchau, in the Karwin district, a borehole has reached a depth of 700 yards. New boreholes have also been put down at Rattimau in Austrian Silesia, in the Kladno district, at Brod on the Save, and at Protwin in Bohemia.†

F. E. Suess † describes the geology of the Rossitz coalfield.

Coal in Belgium.—A. Renier § describes the palæontological methods of studying the stratigraphy of the coal measures, with special reference to the North Belgian coalfield.

Coal in Bosnia.—F. Katzer || gives a detailed account of the brown-coal deposit at Ugljevik, near Bjelina, in north-east Bosnia. The coal is of Miocene age and of good quality.

Coal in Germany.—H. Ottermann ¶ gives a geological description of the Mausegatt main seam in the Witten coalfield.

C. Gäbert ** discusses the possibility of opening up new coalfields in the Erzgebirge.

G. Gürich †† describes the geological structure of the Silesian coal-measures.

At the meeting of the German Geological Society on January 8, R. Michael †† described the geology of the Upper Silesian coalfield.

C. Gaebler §§ describes the Orlau fault in the Upper Silesian coalfield.

It is reported that borings for brown-coal on the slopes of the Hundsberg and Wattenberg (Ehlen) have given very promising results, good beds of lignite, from 15 to 20 feet thick, having been tapped at various points over the entire district. |||

T. Döring ¶¶ gives the results of an elaborate series of tests of the brown-coal from Leipzig, in Saxony. The coal, which has been

* *Times Engineering Supplement*, November 27, 1907, p. 5.

† *Zeitschrift für angewandte Chemie*, vol. xx, p. 2230.

‡ *Jahrbuch der k. k. geologischen Reichsanstalt*, vol. lvii, pp. 793-834.

§ *Revue Universelle des Mines*, vol. xxi, pp. 149-202.

|| *Berg- und Hüttenmännisches Jahrbuch der k. k. montanistischen Hochschulen*, vol. lv, pp. 296-334.

¶ *Glückauf*, vol. xlv, pp. 84-89.

** *Zeitschrift für praktische Geologie*, vol. xvi, pp. 114-119.

†† *Mitteilungen aus dem Markscheiderwesen*, vol. viii, pp. 6-10.

‡‡ *Glückauf*, vol. xlv, pp. 131-132. §§ *Ibid.*, vol. xliii, pp. 1397-1400.

¶¶ *Colliery Guardian*, vol. xcv, p. 136.

¶¶¶ *Jahrbuch für das Berg- und Hüttenwesen im Königreiche Sachsen*, 1907, pp. 3-26

worked by the Government since 1900, has, on account of its high percentage of moisture, a low heating power, but when dried is a valuable fuel.

The occurrence of brown-coal in the province of Brandenburg is described by A. Zeese.*

Coal in Hungary.—J. Andreics † and A. Blascheck describe the coal deposits of the Siu valley.

Coal in Italy.—The occurrence of mineral fuel in Italy is reviewed by K. Stegl. ‡ He gives an account of the occurrence of anthracite, brown-coal, lignite, oil shale, and peat, and refers in detail to the brown-coal in Tuscany, where the deposits are of considerable importance.

A. Zeese § describes the geological occurrence of brown-coal at the Ribolla and Casteani mines.

The coal deposits in the Magra valley are situated at Piampaganello, Caniparola, and Castelnuovo Magra, in the communes of Sarzana and Castelnuovo Magra. Two shafts are at present being sunk, from each of which it is expected to obtain an annual output of 50,000 tons. The sinking of two other shafts is contemplated, which will bring the total production up to 200,000 tons per annum. The quality of the lignite obtained is stated to be vastly superior to any of the so-called coals hitherto discovered in Italy, and recent tests have shown it to possess a heating power of 6435 calories with 2·4 per cent. of ash. ||

Coal in Roumania.—J. Honigl ¶ describes the Valea Copcea lignite deposits in Roumania. The coal contains 40·08 per cent. of carbon, 3·87 per cent. of hydrogen, 15·55 per cent. of oxygen and nitrogen, 26·62 per cent. of moisture, and 13 per cent. of ash.

V. Alimanestiano ** gives details of the occurrence and mining of brown-coal in Roumania.

G. Murgoci †† gives an account of the mining industry of Roumania, with a map of the coal deposits of the kingdom.

Coal in Russia.—F. Gervais †† gives a large number of analyses of Russian coals made in the Government Laboratory.

Coal in India.—In a Presidential address at the inauguration of the Mining and Geological Institute of India, T. H. Holland §§ dealt

* *Braunkohle*, vol. vii. pp. 697-701.

† *Revue du Pétrole*, vol. i. pp. 80-84, 110-112.

‡ *Oesterreichische Zeitschrift für Berg- und Hüttenwesen*, vol. lv. pp. 509-512, 524-530, 552-555, 560-563.

§ *Braunkohle*, vol. vi. pp. 682-684. || *Board of Trade Journal*, vol. lix. p. 417.

¶ *Montan Zeitung*, vol. xiv. pp. 390-392.

** *Revue Universelle des Mines*, vol. xx. pp. 48-64.

†† *Revue du Pétrole*, vol. i. pp. 107-110. ††† *Gorni Journal*, 1907, pp. 243-276.

§§ *Transactions of the Mining and Geological Institute of India*, vol. i. pp. 30-51.

with the relation of science generally to mining and geology, and gives a table showing the classification of Indian strata, both of marine and fresh water formation, and the approximate age of European and American equivalents.

T. H. Holland * and T. H. Ward describe the geology of the Giridih coalfield, and additional particulars of the collieries are given by the latter author. †

T. H. Holland ‡ describes a boulder found in a coal-seam in the Raniganj coalfield.

Coal in Canada.—G. C. Hoffmann § gives analyses of twenty-nine samples of coal and lignite from various localities in Canada.

A summary of the work done by the Department of Mines, Geological Survey, during the year 1907, has been published. There were in the field twenty parties, and the summary reports indicate that a large amount of work was carried out, one of the chief results being the determination of enormous quantities of available bituminous coal in the Yukon region. ||

D. B. Dowling ¶ describes the Cascade coal basin, Alberta. He gives an outline of the geology and topography of the coalfield, and a detailed account of the character of the coal, thickness of seams, and extent of the measures. The report is accompanied by eight folding maps. The area illustrated on the map sheets lies within and to the east of the summit of the Rocky Mountains, the formations exposed giving a continuous section from the highest remaining beds of the Cretaceous down to the bottom of the Carboniferous. The coal is of Cretaceous age. In the hills south of the Bow River ten or eleven seams, more than 4 feet thick, have been found; while north of Bankhead, on the slope of Cascade Mountain, fourteen possibly workable seams occur. At the Bankhead colliery the coal is an anthracite, admirably suited for domestic purposes. A screening plant handling 1000 tons a day has been erected.

D. D. Cairnes ** gives an account of the geology of the Moose Mountain area of the disturbed belt of southern Alberta. Coal has been found in several places within this district, and natural gas has been found to the north, south, and east of this area in the same formations as those within it.

J. J. Bell †† notes the development of the coal resources of Nova Scotia, where the Eastern Coal Company is opening a new mine near Maccan, Cumberland county. The coal is of excellent quality, the main seam measuring 6 feet thick with an additional 5 feet, parted by 5 feet of fireclay. Another seam, the Lawson coal, is 5 feet 6 inches thick, and the seams thicken as they extend eastward, and possibly unite. It is estimated that the three seams contain 90,000,000 tons of coal.

* *Transactions of the Mining and Geological Institute of India*, vol. i. pp. 193-198.

† *Ibid.*, pp. 157-172.

‡ *Ibid.*, pp. 137-146.

§ *Geological Survey of Canada, Bulletin No. 958*, pp. 18-37.

|| *Ibid.*, No. 1017.

¶ *Ibid.*, No. 949.

** *Ibid.*, No. 968.

†† *Engineering and Mining Journal*, vol. lxxxv. p. 106.

A. Lakes * describes the coal deposits at Princeton, British Columbia, near the junction of the Similkameen and Tulameen rivers.

In a description of the economic geology of the Skeena River, W. W. Leach † gives particulars of the occurrence of coal. Coals of Cretaceous age, differing greatly in quality, are widely distributed throughout the district.

The coalfields of Alberta, Saskatchewan, and Manitoba are described by D. B. Dowling.‡

Coal in Cape Colony.—Particulars have been published § of a discovery of lignite in the Knysna district, Cape of Good Hope. On a shaft being sunk to a depth of 30 feet, three seams of the mineral were struck, aggregating 17 feet in thickness. Further tests were made at different places in the same district, and the area containing the lignite was found to be some miles in extent. Trials made with this fuel in Cape Town have given apparently satisfactory results, although, before the importance of the discovery can be fully estimated, experiments will have to be conducted on a larger scale.

Coal in British East Africa.—In a preliminary report on a sample of coal from Mwele, it is pointed out that the coal, when freed from impurities by crushing, sifting, and washing with water, would be quite suitable for conversion into briquettes. A second larger example of this coal was received subsequently, and the results of the examination are as follows :||—

	First Sample Washed Coal.	Second Sample Unwashed Coal.
	Per Cent.	Per Cent.
Fixed carbon	59·95	43·08
Volatile matter	26·17	27·80
Ash	3·50	16·07
Sulphur	0·03
Phosphorus	0·007
Moisture	10·38	13·05
Dirt (in crude coal)	31·00	...
Calorific value	5814 calories.	4419 calories.

Coal in New South Wales.—A memoir by T. W. E. David,¶ on the geology of the Hunter coalfield in New South Wales, is the outcome of many years' field work. The structure of the field is illustrated by two maps, on which are traced the outcrops, and a series of twelve sections, in which the relations of the various measures and

* *Mining World*, vol. xxvii. pp. 547-548.

† *Journal of the Canadian Mining Institute*, vol. x. pp. 218-228.

‡ *Ibid.*, pp. 229-241.

§ *Board of Trade Journal*, vol. lix. pp. 326.

|| *Bulletin of the Imperial Institute*, vol. v. pp. 241-243.

¶ *Geology of the Hunter Coalfield*. Sydney: Department of Mines, 1908.

their coal-seams are clearly shown. The author furnishes an estimate of the available coal in the Greta measures, placing it at 1,893,000,000 tons, of which 1,262,000,000 tons are workable. The coal in the upper, or Newcastle, measures is estimated at 3,278,000,000 tons.

Coal in Western Australia.—Notes on plant remains from the Collie coalfield are given by R. Etheridge,* on fossils from the same coalfield by F. Chapman, and on fossils from the Irwin River coalfield by R. Etheridge. These papers throw light upon the vexed question of the geological age of the Collie River coal-measures, and are of scientific interest in their relation to the important question of the distribution of *Glossopteris* flora. A re-examination of two leaf fragments, previously thought possibly to belong to the Mesozoic genus *Sagenopteris*, proved them to belong to the Palæozoic genus *Glossopteris*.

In a paper on the mineral resources of Western Australia, C. H. Rason † notes the occurrence of coal both in the north and the south of the South-Western division. The only deposits at present worked are those on the Collie River.

Coal in Victoria.—The brown-coal deposits of Victoria are described by R. A. F. Murray. ‡

Coal in New Zealand.—In his monograph on the Parapara Subdivision, Karamea, Nelson, J. M. Bell § states that thin seams of brown-coal, associated with the lowest beds of the Miocene strata, outcrop at several points near the Golden Ridge, at Rangihaieta Head, at Motupipi, and elsewhere in the Takaka Valley. The coal is, generally speaking, of low grade, being high in ash and sulphur. Coal of better quality than that now exposed may occur beneath the surface where the uppermost measures of the Oamaru rocks appear in the Takaka Valley and in the Aorere Valley. In the Aorere Valley north of Rockville, the possibilities of coal beneath the surface, where Oamaru rocks outcrop, seem especially hopeful, since on the Wakamarama Range, to the north-west, the upfaulted members of the Oamaru rocks—the equivalents of those in the Aorere Valley—contain coal-seams. Boring operations for coal might be carried out in this locality with a reasonable hope of success.

L. H. Harrison || describes the occurrence of free sulphur and of calcium sulphate crystals in a coal from Boby's Creek, Waipara.

A report on New Zealand coals exhibited at the New Zealand International Exhibition at Christchurch has been made by J. MacLaurin. ¶ The semi-anthracites, although not so rich in fixed

* *Geological Survey of Western Australia, Bulletin No. 27.*

† *Journal of the Royal Society of Arts*, vol. lvi. pp. 533-544.

‡ *Australian Mining Standard*, January 8, 15, and 22, 1908.

§ *New Zealand Geological Survey, Bulletin No. 3*, p. 104.

|| *Transactions of the New Zealand Institute*, vol. xxxix. pp. 475-476.

¶ *Report of the Analyst to the Mines Department, New Zealand; Iron and Coal Trades Review*, vol. lxxvi. p. 433

carbon as the samples of Welsh anthracite, are equal to those in evaporative power, and surpass them in their comparative freedom from sulphur. They should prove excellent steaming coals. The bituminous coals from Paparoa, Westport, Port Elizabeth, and Brunner are somewhat better than the samples of Canadian and New South Wales coals given for comparison. They are low in water and low in ash, and, though in some cases high in sulphur, are excellent steam and gas producing coals. They would make very good coke, and are also good for household purposes. The other bituminous coals, though not giving so fierce a heat when burned, are also very good steaming coals, and better perhaps than the first for household use. They make excellent coke—a fact well exemplified in the first-class quality for smelting purposes of the sample of coke submitted for analysis from the Brunnerton mine. Bituminous coals are confined to the west coast of the South Island. Brown-coals are extensively mined, and are largely used for household purposes both in the North and South Islands. Where the better class of coals are not available they are used for steam-raising, and, though somewhat light, give very fair results. No hard and fast line can be drawn between the brown-coals and the lignites—the next class. They pass by insensible gradations into one another. The lignites are worked in Otago and Southland, and their use is mainly local, for household purposes, and for steam when no other fuel is available.

Coal in the United States.—G. Baum describes the geological structure of the various American coalfields.*

The United States Geological Survey has been giving more and more attention to the subject of coal, and a synopsis of the results accomplished during the past year has been published. A classified list of papers dealing with coal in publications of the Survey, compiled by W. T. Lee † and J. M. Nickles, is appended.

Coal in Alabama.—The northern part of the Cahaba coalfield is described by Charles Butts. ‡ The coalfield has a total area of 150 square miles. The coals are all bituminous, the average composition being 2½ per cent. of moisture, 59 per cent. of fixed carbon, 32 per cent. of volatile matter, 6 per cent. of ash, and 1 per cent. of sulphur.

Coal in Arkansas.—The Arkansas coalfield is described by A. J. Collier.§ The deposits are extensive, and the coals, which are of excellent quality, range from bituminous to semi-anthracite.

Coal in California.—A new coalfield is being opened up in California, near the coast, between San Francisco and Los Angeles, which is expected to have an important effect on the fuel supply conditions

* *Glückauf*, pp. 415-421.

† *United States Geological Survey, Bulletin No. 316*, pp. 518-532.

‡ *Ibid.*, pp. 76-115.

§ *Ibid.*, pp. 137-160.

in the district. Unlike most beds in the State, which are lignitic in character, this one is said to be a seam of semi-bituminous coal, 18 feet thick. About $1\frac{1}{2}$ miles of gangways have been opened up, and it is expected that the mines will soon be producing several hundred tons of coal per day.*

M. R. Campbell † describes the Lower Miocene coal of Stone Cañon, Monterey county. It is the best coal on the Pacific coast south of Washington.

Coal in Colorado.—The coalfields of Colorado are described by A. Lakes. ‡

Descriptions have been published of the coalfields of the Danforth Hills and Grand Hogback in north-western Colorado by H. S. Gale, § of the Brook Cliffs coalfield between Grand River and Sunnyside, Utah, by G. B. Richardson, || and of the Durango coal district by J. A. Taff. ¶

Coal in Illinois.—Coal investigations in the Saline-Gallatin field are described by F. W. De Wolf.** The area described covers 550 square miles.

Coal in Kentucky.—C. H. Davis, †† in an account of the Kentenia Corporation, describes the coal deposits of Kentenia, giving numerous illustrations showing the vast supply available of coal of excellent quality.

The Elkhorn coalfield is described by R. W. Stone. ††

Coal in Michigan.—The coal resources of Michigan are described by L. Fraser, §§ who describes the geology of the measures, and gives analyses of the coal, together with maps of the Bay county coalfield and plans of the leading mines.

Coal in Montana.—F. W. Parsons ||| gives an account of the coal resources of Montana, and a map showing the coal and lignite areas of the State. There are 47,200 square miles of coal lands, and Montana at present produces about 18 per cent. of all the coal and lignite mined in the Rocky Mountain region, the bulk of the output being derived from the ten largest mines. The entire production is consumed locally, and is even then insufficient to meet the demand.

F. W. Parsons ¶¶ gives an account of the coal-beds of Montana, and of the composition of the principal coals encountered. New fields are

* *Engineer*, vol. cv. p. 89.

† *United States Geological Survey, Bulletin* No. 316, pp. 435-438.

‡ *Mining World*, vol. xxviii. pp. 525-526.

§ *United States Geological Survey, Bulletin* No. 316, pp. 264-301.

|| *Ibid.*, pp. 302-320.

¶ *Ibid.*, pp. 321-337.

** *Ibid.*, pp. 116-136.

†† *Supplement to the Harlan Enterprise*, April 10, 1908.

‡‡ *United States Geological Survey, Bulletin* No. 316, pp. 42-54.

§§ *Engineering and Mining Journal*, vol. lxxiv. pp. 1024-1027.

||| *Ibid.*, pp. 978-981.

¶¶ *Ibid.*, pp. 1071-1074.

being rapidly developed in Carbon County, which contains over 3000 square miles of coal lands lying in the Laramie and Fort Union formations.

Descriptions have been published of the Great Falls coalfield by C. A. Fisher,* of the coals of Carbon County by N. H. Darton,† and of the coalfields of part of Dawson, Rosebud, and Custer counties by A. G. Leonard.‡

Coal in New Mexico.—A reconnaissance survey of the western part of the Durango-Gallup coalfield of Colorado and New Mexico is described by M. K. Shaler,§ and descriptions have been published of the Una del Gato coalfield, Sandoval County, by M. R. Campbell,|| and of coal in the vicinity of Fort Stanton Reservation, Lincoln County, by the same author.¶

Coal in Pennsylvania.—The United States Geological Survey has made very detailed surveys since 1900 of an area of coalfields of about 5000 square miles. Recent results are given in papers on coal in the Clarion quadrangle by E. F. Lines,** and on the coal resources of Johnstown by W. C. Phalen.††

Coal in Utah.—The coal district in the region about Pleasant Valley, Carbon and Emery counties, is described in detail by J. A. Taff.‡‡

The coalfields of Iron County, in south-western Utah, were examined by W. T. Lees,§§ who has published a brief description. These coalfields are the most important of the south-west, and some day may furnish fuel to the desert region of the southern part of the Great Basin.

Coal in Virginia.—The coal resources of West Virginia are discussed by F. W. Parsons,||| who points out that the increase in the production of coal was greater in this State during 1906 than in any other in the United States. There are three important coalfields—Kanawha, New River, and the Pocohontas. The first-named contains six persistent coal-beds—the Stockton, Coalburg, Winifrede, Cedar Grove, Campbell's Creek, and Eagle seams. The coal from the Coalburg and Winifrede seams is splinty. The best coal comes, however, from the New River field. Analyses are given showing this coal to possess high qualities.

The Russell Fork coalfield is described by R. W. Stone,¶¶ and coal-mining at Dante is dealt with by the same author.***

* *United States Geological Survey, Bulletin No. 316*, pp. 161-173.

† *Ibid.*, pp. 174-193.

‡ *Ibid.*, pp. 194-211.

§ *Ibid.*, pp. 376-426.

|| *Ibid.*, pp. 427-430.

¶ *Ibid.*, pp. 431-434.

** *Ibid.*, pp. 13-19.

†† *Ibid.*, pp. 20-41.

‡‡ *Ibid.*, pp. 338-358.

§§ *Ibid.*, pp. 359-375.

||| *Engineering and Mining Journal*, vol. lxxxiv, pp. 881-885.

¶¶ *United States Geological Survey, Bulletin No. 316*, pp. 55-67.

*** *Ibid.*, pp. 68-75.

Coal in Wyoming.—In a monograph on the geology of the Bighorn Basin, C. A. Fisher* gives an account of the occurrence of coal, which is the chief product of the sedimentary formations of the basin. It occurs mainly in the so-called Laramie formation, and the greatest development is found where the larger streams expose the coal-measures. The various districts where the principal development of the coal deposits has taken place are separately described.

F. W. Parsons † deals with the coal resources of northern Wyoming. Most of the supplies are of inferior quality and high in moisture. They are therefore unfit for long storage or transportation. Although some of the coal is cokable, most of the output is used for steam and domestic purposes. The seams vary from 6 to 20 feet in thickness, but contain numerous partings of slate, which necessitates great care in mining in order to obtain a clean product. The oldest field in north-east Wyoming is at Cambria, eight miles north of Newcastle. This field contains the only bituminous coking coal hitherto discovered in the district. The Cambrian Fuel Company, which works the deposit, owns 17,000 acres of coal-bearing land. The coal is of unique quality, inasmuch as it carries small quantities of gold and silver. The Cambria coal is hard, and partakes of the nature of a bituminous shale or cannel. In the Sheridan district is another coalfield, 150 miles west of Newcastle. The coal in this field is a lignite, and far inferior in fuel efficiency to the Cambria coal. Altogether there are about 20,000 square miles of coal lands in northern Wyoming.

The coal resources of Wyoming are described, with special reference to the Diamond coalfield, by A. T. Shurick. ‡ This coalfield is situated on the Oregon Short Line Railroad, 270 miles north-east of Salt Lake. Coal was first discovered in 1843, and again in 1848 and 1852, but the first important development was in 1894. The coal was found to be of excellent quality and high calorific value (7560 calories). The field is a good deal faulted.

The coal-mines of southern Wyoming are described by F. W. Parsons.§

Descriptions have been published of the coalfields in a portion of central Uinta county by A. R. Schultz,|| of the Lander coalfield by E. G. Woodruff,¶ of the coalfields of east-central Carbon County by A. C. Veatch,** and of the coal of Laramie Basin by C. E. Siebenthal. ††

Coal in the Island of Saghalien.—According to investigations made by the Karafuto Administration Office, coal is the most important and richest of the various mineral products of the island of Saghalien, the quality being excellent and the depth of the coal-seam measuring over 50 feet in some places. The deposits extend over almost the whole dimensions of the island from Notoro Point,

* *United States Geological Survey, Professional Paper No. 53, pp. 46-56.*

† *Engineering and Mining Journal, vol. lxxxiv. pp. 930-935.*

‡ *Ibid.*, vol. lxxxv. pp. 116-118.

§ *Ibid.*, pp. 118-120.

|| *United States Geological Survey, Bulletin No. 316, pp. 212-241.*

¶ *Ibid.*, pp. 242-243.

** *Ibid.*, pp. 244-260.

†† *Ibid.*, pp. 261-263.

southern extremity, to the boundary line at 50 degrees north latitude. Details of the more important deposits are given.*

Coal in Japan.—J. H. C. Mingaye † gives analyses of Japanese coals.

Coal in Peru.—E. I. Dueñas ‡ describes the occurrence of coal in the department of the Cuzco. Tertiary coal is met with at Paruro, Levitaca, Chimboya, and adjoining districts, while mesozoic coal occurs at Livitaca.

Coal in the Sahara.—G. B. M. Flamand § has recently contributed a paper to the Geological Society of France, in which he declared that the existence of coal-measures in the extreme south of Oran was now established on a scientific basis, although he would not go so far as to vouch for the presence of commercially workable seams of coal.

Peat.—In Sweden,|| where for many hundred years fuel has been obtained in the form of peat from the Swedish moors, a series of experiments has been carried out by the Swedish Peat Development Company with interesting results. From twenty-three experiments of this material the average ash in the water-free condition was found to be 3·71 per cent. An analysis of the dry organic part of the material gave as an average, carbon, 57·04 per cent. ; hydrogen, 5·74 per cent. ; oxygen, 37·17 per cent. The nitrogen varied between 0·71 and 3·16 per cent., or an average of 2·22 per cent. ; the sulphur varied from 0·4 to 0·6 per cent., being chiefly in organic combination in the peat itself, only a small part being found as sulphate in the constituents of the ash. The following analyses, the one on the water-free material and the other when containing 25 per cent. of water, may be taken as the average composition of the material employed in Sweden :—

	Water-Free. Per Cent.	Twenty-five per Cent Water.
Ash	3·70	2·78
Carbon	54·90	41·17
Hydrogen	5·60	4·20
Oxygen	33·25	24·94
Nitrogen	2·12	1·59
Sulphur	0·43	0·32
Total	100·00	75·00

* *Journal of the Yokohama Chamber of Commerce*, November 1907; *Board of Trade Journal*, vol. ix. p. 27.

† *Records of the Geological Survey of New South Wales*, vol. viii. pp. 251-257.

‡ *Boletín del Cuerpo de Ingenieros de Minas del Peru*, No. 58.

§ *Colliery Guardian*, vol. xciv. p. 40.

|| *Oesterreichische Moornzeitschrift*, 1907, pp. 105-155.

According to the investigations of G. von Heidenstam, peat has on an average 22 per cent. of water with 3.79 per cent. ash in the water-free condition, or 2.95 per cent. as existing with 22 per cent. water. The calorific value of the dry peat is 54,005 calories or 3809 effective calories with 22 per cent. of water. In comparison with peat from other countries the Swedish peat is very low in ash.

V. Zailer* and L. Wilk discuss the influence of the constitution of plants on the physical and chemical properties of peat.

The production of ammonia from peat by the Woltreck process is described by A. Halstead.† The method consists of passing a mixture of air and water vapour over peat kept at a low heat in specially devised furnaces.

The peat deposits of Georgia and Florida are described by the Acting British Consul at Savannah.‡ In Southern Georgia and Florida there exist great peat bogs in which are stored almost incalculable quantities of this fuel. Similar bogs are also said to exist in nearly every state and particularly in those that border on the sea. At the present time the only peat bog being worked in Florida is a large deposit situated near Orlando, where operations are carried on in rather a crude manner.

Peat from the Falkland Islands§ yielded on analysis: fixed carbon, 20.88 to 28.90 per cent.; volatile constituents, 35.39 to 57.26; moisture, 11.13 to 37.23; and ash, 2.71 to 10.00.

Weathering of Coal.—The weathering of coal forms the subject of an investigation by S. W. Parr|| and N. D. Hamilton. They find that an exudation of combustible gases from coal occurs from the time of breaking out of the sample from the seam, and that an absorption of oxygen accompanies the exudation. The process of deterioration is probably due to oxidation of hydrogen or of hydrocarbons. It may also be due to a simple loss of combustible gases and their replacement by oxygen. The extent of the deterioration varies with different coals, but the deterioration is probably most active during the first two or three weeks from the taking of the sample.

Experiments made to determine the effect of storing coal under water are described by J. Hart.¶ The only detrimental result found was the absorption of water by the coal.

Sampling Coal.—The technological work on fuels of the United States Geological Survey has consisted largely of the testing of wagon-load samples of coal. This work has been under the charge

* *Zeitschrift für das landwirthschaftliche Versuchswesen in Oesterreich*, 1907, pp. 787-816.

† *Engineering and Mining Journal*, vol. lxxxiv. p. 917.

‡ *Iron and Coal Trades Review*, vol. lxxvi. p. 62.

§ *Bulletin of the Imperial Institute*, vol. v. pp. 251-252.

|| *University of Illinois, Bulletin No. 17.*

¶ *Chemiker Zeitung*, vol. xxxi. p. 1257.

of J. Shober Burrows,* who has made a detailed study of methods of sampling. A brief account of these results is given in a paper on the importance of uniform and systematic coal-mine sampling.

III.—CHARCOAL.

Charcoal Kilns.—It is reported † that two new charcoal kilns have been completed near Sundsvall. They are of the Jonsson-Härden type, and excellent results have been obtained both as regards yield of charcoal and of by-products.

R. Duchemin ‡ deals with charcoal-burning.

Charcoal By-products.—W. C. Geer § discusses the products of wood distillation. Two processes are employed—destructive distillation and steam distillation. The latter, as a rule, effects the separation of the volatile products with little decomposition of the wood fibre. Wood is heated or carbonised in three forms of apparatus—in brick kilns, in retorts, and in ovens. Four crude products are obtained—(1) charcoal; (2) a non-condensable gas; (3) an aqueous product known as pyroligneous acid; and (4) wood tar. The uses to which the various products are put are then dealt with, and the yield stated for various descriptions of wood. The charcoal is, of course, largely used for blast-furnaces.

A description has appeared of the by-product plant installed at the charcoal ironworks at Marquette, Michigan. ||

The Charcoal Industry in Sweden.—Although the old-fashioned method of charring still prevails in most parts of Sweden, and is applied to the bulk of the charcoal made in the country, newer and more rational systems are by degrees being adopted, and during the last year or two several new installations have been completed. The American system has been followed in some instances, more especially at saw-mills in North Sweden with plate retorts, whilst in some cases lower down in the country brick chambers have been chosen in preference to the plate retorts. In the brick chambers the heat is conveyed by cast-iron pipes, which receive the gases from the furnace. Other modifications have been resorted to in one or two places, and the whole question is at present receiving considerable attention. The same remark applies to the introduction of improved methods for utilising the auxiliary products. Several new installations, based upon recently discovered methods, are under contemplation. ¶

* *United States Geological Survey, Bulletin* No. 316, pp. 486-517.

† *Affärsvärlden*, vol. vii. p. 1284.

‡ *Génie Civil*, vol. liii. pp. 290, 301-302.

§ Circular 114, Forest Service, United States Department of Agriculture.

|| *Engineering Record*, October 12, 1907.

¶ *Engineering*, vol. lxxxv. p. 15.

IV.—*COKE.*

Beehive Coke-ovens.—A description has been published* of the plant of the Orient Coke Co., Dunlaps Creek Valley, Pennsylvania. There are 480 coke-ovens in operation, arranged in three double rows, with 80 ovens to each yard. Covington coke extractors are installed in two of these yards, and a third one will be put in shortly. All the ovens are of the beehive type, 12 feet 3 inches by 8 feet, and produce an unusually good grade of coke. The equipment of the mine from which the coal for coking is obtained is also described.

An illustrated description has appeared † of the new plant of the Connellsville Central Coke Company, near New Salem, Pennsylvania. It consists of a battery of longitudinal or modified Belgian type of coke-ovens, a type which is becoming popular throughout the coke districts of Pennsylvania. The completed plant will consist of 400 of these ovens, the chief advantages of which are that they can be drawn within 15 seconds, and recharged, levelled, closed, and ignited within 40 minutes, whereas with beehive ovens and hand-forking and bricking-up, 3 hours and 20 minutes were required for these operations. The new ovens are 30 feet long inside, with cast-iron brick-lined doors 5 feet wide at the front or discharging end, and 4 feet 10 inches wide at the back. The new plant is completely equipped with electrically operated Wellman-Seaver-Morgan pushing, levelling, and quenching machines, the construction of which is described and illustrated. Compressed air is used to blow all dust, ashes, and dirt from the coke before quenching, and effectively cleans the coke.

The mechanical appliances for handling coke are described by E. Körting ‡ and by F. Kellner.§

W. W. Macfarren || gives a detailed description of various types of coke-drawing machines. The growth of the coke industry of the United States has been so rapid that whereas in 1892 there were but 261 plants, with a total of 40,000 ovens, it is computed that on April 1, 1907, there were in the Connellsville district alone 37,000 ovens, with over 2000 additional ovens projected. The great bulk of these ovens are of the beehive type, and the hand-drawing of such ovens is a laborious and difficult piece of work, which it is becoming increasingly difficult to get men to perform. Coke-drawing by machinery is thus cheaper and more expeditious than the older manual methods, although one of the objections hitherto made to their employment is that hand-drawn coke is withdrawn in nearly its original size as coked, while coke-drawing machines break it up, more or less, during extraction. The requirements of a good coke-drawing machine are reliability,

* *Mines and Minerals*, vol. xxviii. p. 177.

† *Iron Trade Review*, vol. xli. pp. 785-790.

‡ *Journal für Gasbeleuchtung*, vol. l. p. 125.

§ *Ibid.*, p. 245.

|| *Proceedings of the Engineers' Society of Western Pennsylvania*, vol. xxiii. pp. 451-516; *Iron Trade Review*, vol. xli. pp. 995-1002, 1035-1039.

capacity, economy of operation, the delivery of large clean coke to the wagons, a "low" construction of machine or a "high" yard, permitting the drawing of the coke by hand when necessary, strong construction, not liable to be easily injured by foolish manipulation, and that the first cost and the expenses of maintenance should be low. The machines described are the Hebb machine, the Alliance machine, which resembles it, the Covington machine, the Heyl and Patterson machine, and the Marmac coke-drawing and loading machine. The Covington machine and the Marmac machine are described at some length. The former was the first complete machine to obtain any degree of success. It consists of an extractor and a conveyor, and it requires two men to handle it. It is chiefly made of cast iron, and the construction is cheap. The machine draws about 90 per cent. of the coke, the remaining amount being withdrawn by hand. The Marmac machine has been designed to rectify some of the defects of the Covington machine, which it resembles in many respects. Diagrams and illustrations of the working parts are given.

J. M'A. Johnston * describes the application of Stirling and other water-tube boilers to coking plant.

By-product Coke-ovens.—W. H. Coleman † describes the processes of recovery of by-products from coke-ovens, and discusses the possible outlet for the products. He anticipates an increased demand for benzol as a motor-car fuel. In 1902 only about 10 per cent. of the total output of coke in Great Britain was made in by-product recovery-ovens, while figures published by the Board of Trade show that the number of recovery-ovens used has increased from 5546 in 1905 to 6275 in 1906. The processes for the recovery of by-products are described in great detail, and the method of their disposal is also dealt with.

E. M. Hann ‡ describes a recent plant for the utilisation of small coal. The plant, which has been erected at the Bargoed colliery, comprises a washery, treating 120 tons per hour, driven entirely by three-phase electric motors, and 50 coke-ovens of the Koppers type. By the means adopted in the plant the wastes have been reduced to about 10 per cent. of the coal used. Eleven folding plates, illustrating the plant, accompany the paper.

An illustrated description has appeared § of the Armstrong vertical-circular by-product coke-oven. The object to be attained by this form of oven is to manufacture high-class coke, under the same conditions as in the beehive oven, from any description of coking coal, saving all the by-products, and giving a larger daily output per oven, with a larger quantity of coke per ton of coal than is possible with the ordinary horizontal by-product oven. The new oven is vertical, so that the full weight of the charge maintains a considerable pressure during

* *Transactions of the Institution of Mining Engineers*, vol. xxxv. pp. 98-114.

† *Ibid.*, vol. xxxiv. pp. 331-348.

‡ *Proceedings of the South Wales Institute of Mining Engineers*, vol. xxv. pp. 469-487.

§ *Colliery Guardian*, vol. xcv. pp. 123-124.

the coking period. Its circular form has been adopted for various reasons, amongst which are cheapness of construction, greater stability, uniformity and quickness of heating, and large output. The oven is heated with a portion of the gas from which the by-products have been extracted, and is regenerative. The gas is burned with heated air, and the regenerators are designed to serve two purposes; firstly, to keep the outside walls cool, and, secondly, to heat the air for combustion.

An illustrated description of the Koppers by-product recovery coke-oven, with detailed drawings showing the construction, has appeared.* There are two forms of Koppers oven—the waste-heat oven and the regenerative oven, the latter producing the waste heat wholly in the form of combustible gas. Both types are described. In the regenerative oven automatic reversing has been introduced, the gas and air supply being automatically regulated by electrical means every half-hour. The condensation apparatus introduces a novel feature, as the raw gases are treated with sulphuric acid after the tar has been deposited, in order to dispense with the washers for the absorption of ammonia. At the same time the resulting sulphate is discharged mechanically to secure continuous operation and avoid hand labour. A description is given of the Koppers plant installed at the Mont Cenis colliery. Similar ovens have recently been adopted in the United States, at Joliet, Illinois.

In the course of an extended account of the new ironworks of the Staveley Company, a description is given † of the hundred Simplex coke-ovens divided into four batteries. The drawings given show that the ovens are of the well-known horizontal flued type, fractional combustion ensuring a homogeneous temperature throughout. The quantity carbonised per week is 3500 tons of dry slack, and the yield in sulphate of ammonia and tar averages respectively 1.52 per cent. and 3.93 per cent.; the average volatile matter contained in the dried slack is 35 per cent., and the yield of metallurgical coke reaches 65 per cent. These results are highly satisfactory, considering that the superior yield of the ovens over the laboratory tests completely makes up for the usual losses in coke-dust and small breeze. The proportion of breeze and dust produced never exceeds $4\frac{1}{2}$ per cent., which, considering the natural brittleness of the coke, points to the good results obtained in these circumstances by coal-compression.

E. Körting ‡ compares the Dessau vertical coking retorts with inclined retorts.

New types of coke-ovens are described by F. Fieschi.§

S. B. Sheldon describes his type of coke-oven.||

Ostwald's process for the production of nitric acid and nitrate of ammonia from ammoniacal liquor, as applied to the gas and coke-

* *Iron Age*, vol. lxxx. pp. 1671-1675.

† *Engineering*, vol. lxxxv. p. 573-576.

‡ *Journal für Gasbeleuchtung*, vol. I. pp. 145-151.

§ *Génie Civil*, vol. lii. pp. 299-301.

|| *Iron Age*, vol. lxxxi. pp. 197-201.

oven industries, is described and illustrated by F. D. Marshall,* who describes earlier attempts to solve the problem. The ammonia daily produced in large quantities by the destructive distillation of coal is by this process converted directly into pure nitric acid of 53 per cent. strength, and the acid in its turn is converted into nitrate of ammonia if so desired. When the process is conducted on a large scale existing ammonia stills can be utilised, the acid saturators being dispensed with in favour of the "catalysers," the only addition being the acid-proof brick condensing towers. Should the process be continued, as at Bochum, for the manufacture of nitrate of ammonia, the acid is conveyed to the nitrate saturators in another building. No purification of the ammonia vapour entering the "catalysers" is necessary, and any foreign nitrogen compounds—such as aniline, pyridine, or hydrocyanic acid—are burnt to nitric acid, while sulphur compounds burn to sulphuric acid, which is easily removed from the nitric acid by a single distillation.

The ammonia employed may be supplied by gas-works, coke-ovens, town waste, or fermented urine; or, in fact, from any source from which ammonia in payable quantities is obtainable, while the process is clean, noiseless, and demands the minimum of attention and labour.

Taking the average results from the manufacture of sulphate from gas-works and coke-ovens, the net profit is about 2s. on every ton of coal carbonised, varying, naturally, according to the facilities for obtaining sulphuric acid. 100 tons of coal produce 2 tons of nitric acid of 53 per cent. and $\frac{3}{4}$ of a ton of ammonium nitrate.

A very important and growing application of nitric acid is for obtaining nitro-benzene, nitro-naphthalene, &c., from the corresponding hydrocarbon compounds. As these substances are recovered from coke-ovens at the same time as ammonia, it is possible to avoid the transportation of the nitric acid altogether, and to produce nitro or amido compounds direct instead of hydrocarbons and nitric acid. The whole subject has recently been fully dealt with by W. Rabius.†

A. Thau ‡ describes the starting of by-product coke-ovens.

In the United States, the Koppers regenerative by-product coke-oven system has been introduced from Germany, and the first plant was built at Joliet.§ Two new coke-oven charging machines were also introduced. The Ernst machine for rectangular ovens has a steel plate box the size of the oven. This is filled with coal and thrust into the oven. The rear end is then held by a ram, while the box is pulled out—the front end being hinged—leaving the mass of coal in place. The Marmac machine, for drawing and charging beehive ovens, has a cast-steel wedge-shaped shovel, 40 inches by 15 inches, on the end of a ram, which is rotated on its axis to discharge coal into the oven or coke upon a conveyor. All the apparatus is mounted on a travelling platform.

* *Iron and Coal Trades Review*, vol. lxxv. pp. 2323-2324.

† *Critical Considerations and the Prospective Solution of the Nitrogen Problem*. Jena: G. Fischer.

‡ *Glückauf*, vol. xlv. pp. 265-271.

§ *Engineer*, vol. cv. p. 107.

An illustrated description has appeared * of the Ernst coal-charging machine for by-product coke-ovens and for the so-called rectangular Belgian ovens recently introduced in the Connellsville region of Pennsylvania. The Ernst coal-charging machine introduces the coal through the side of the oven, and, as no levelling is necessary, the process of coking the new charge can begin again one minute after the previous charge has been pushed out of the oven.

Coloured drawings have been published † of new Otto regenerative coke-ovens, fired from below, experimentally installed at the Deutscher Kaiser works.

Coke-oven Gases.—The utilisation of coke-oven gases is discussed by L. Greiner. ‡

Peat-coke.—The problem of peat utilisation, so often pronounced hopeless, is now stated to have been practically solved. The Mond Power-Gas Corporation are building a large peat-generator gas-plant near Herne, in Westphalia; Crossley Brothers are projecting plants on the basis of their long-continued experiments at Openshaw; and Martin Ziegler has made peat-coke and obtained the chemical by-products, at Oldenburg and at other places, ever since 1897. The Ziegler plant at Beuerberg, in Upper Bavaria, which was opened in 1906, is described.§ The results obtained have been eminently satisfactory, and suggest the possibility of manufacturing at a profit peat-coke and chemicals in Ireland, where from 16 feet to 40 feet of peat can be worked over large areas.

L. C. Wolff || describes the coking of peat with recovery of by-products, as carried out at Beuerberg, in Upper Bavaria.

H. Bergström ¶ describes the manufacture of peat coke in Sweden.

V.—LIQUID FUEL.

Origin of Petroleum.—Hypotheses as to the origin of petroleum continue to attract much attention. The subject is discussed by N. I. Andrussoff ** from a geological standpoint.

M. P. de Wilde †† considers that the theory of the formation of petroleum from organisms has no scientific basis, and that in view of the occurrence of petroleum in eruptive rocks, a purely inorganic origin must be accepted.

* *Iron Age*, vol. lxxx. p. 1682.

† *Zeitschrift für das Berg-, Hütten- und Salinenwesen*, vol. lvi. pp. 181-182.

‡ *Cassier's Magazine*, vol. xxxiii. pp. 68-82.

§ *Engineering*, vol. lxxxiv. pp. 671-676.

|| *Zeitschrift für Dampfkessel und Maschinenbetrieb*, 1907, p. 450.

¶ *Bihang till Jernkontorets Annaler*, 1908, pp. 19-26.

** *Revue du Pétrole*, vol. i. pp. 72-74. (In German, with summary in Roumanian.)

†† *Moniteur Scientifique*, vol. xxi. pp. 301-307; *Petroleum*, vol. ii. p. 326.

Researches by G. Krämer * lead him to support Engler's theory that petroleum has been formed from algæ.

J. Marcusson † shows that the optical activity of petroleum is opposed to the theory of inorganic origin. Researches on the optical activity of petroleum have also been described by R. Zaloziecki ‡ and H. Klarfeld, and by M. A. Rakusin.§

The synthetic preparation of optically active petroleum from glycerides is described by J. Lewkowitsch.||

M. A. Rakusin ¶ gives the results of an elaborate series of optical investigations of petroleum.

The polarimetry of petroleum has been investigated by M. Reinhard ** and N. Botez.

The chemistry and physics of petroleum formation are discussed at length by C. Engler.††

Petroleum in Scotland.—W. G. Peasegood ‡‡ records the occurrence of petroleum in the Bullhurst coal-seam, Leycett collieries.

Petroleum in Austria.—J. Noth §§ describes the occurrence of petroleum near Sanok, in Galicia.

M. Wielezynski ||| gives the calorific values of various Galician crude petroleum.

In a biography of Balthasar Hacquet (1739–1815), a native of Brittany, who practised as mine physician at the Idria mines from 1766 to 1773, A. Müllner ¶¶ enumerates the various memoirs relating to mineralogy written by Hacquet and now forgotten. Amongst them is an account of the Styrian ore mountain in 1774. Incidentally it is pointed out that Hacquet directed attention to the occurrence of petroleum in Galicia, eighty years before the usually accepted date of its discovery.

Petroleum in Hungary.—G. Rez *** describes the occurrence of petroleum in Hungary.

Petroleum in Italy.—J. Markus ††† traces the history of petro-

* *Chemiker Zeitung*, vol. xxxi. pp. 675–677.

† *Mitteilungen aus dem kgl. Materialprüfungsamt*, vol. xxv. pp. 124–135; *Chemiker Zeitung*, vol. xxxi. pp. 419–422.

‡ *Ibid.*, pp. 1155–1156, 1170–1172.

§ *Journal of the Russian Physical and Chemical Society*, vol. xxxix. pp. 802–814.

|| *Berichte der deutschen chemischen Gesellschaft*, vol. xl. p. 4161.

¶ *Revue du Pétrole*, vol. i. p. 146; *Petroleum*, vol. ii. p. 439.

** Paper read before the Society of Sciences of Bucharest; *Revue du Pétrole*, vol. i. pp. 10–14.

†† *Petroleum*, vol. ii. pp. 849–853, 912–916, 964–967, 1021–1025.

‡‡ *Transactions of the Institution of Mining Engineers*, vol. xxxv. pp. 116–120.

§§ *Allgemeine Oesterreichische Chemiker und Techniker Zeitung*, vol. xxv. pp. 9–10, 17–18.

||| *Petroleum*, vol. ii. pp. 507–509.

¶¶ *Berg- und Hüttenmännisches Jahrbuch der k.k. montanistischen Hochschulen*, vol. lv. pp. 339–371.

*** *Banyassati es Kohassati Lapok*, vol. xli. pp. 145–150.

††† *Chemiker Techniker Zeitung*, vol. xvii. pp. 145–147.

leum discoveries in Italy, and notes the places and depths at which petroleum has recently been found.

Petroleum in Portugal.—E. Ackermann * records the starting of systematic boring for petroleum at Torres Vedras in Portugal. The decided indications of petroleum in some of the districts of Portugal are chiefly confined to the upper Jurassic formation. The upper Jurassic series in Portugal is composed of beds of limestone, some of which exhibit the Oolitic structure characteristic of some calcareous rocks of that period.

It is reported † that the recent discovery of petroleum in the province of Angola may prove to be of importance. Prospecting has been carried on in the district of Dande.

Petroleum in Roumania.—T. Ficsinesco ‡ and V. Dessila give an account of the occurrence of petroleum in Roumania.

L. Schick § traces the development of the Roumanian petroleum industry.

V. Aradi || describes the petroleum deposits of Roumania, and gives ¶ an account of the Campina petroleum fields.

P. Poni ** has examined four samples of petroleum from different wells in the Campina district of Prahova, in order to determine whether the aromatic hydrocarbons, which have been obtained by the distillation of Roumanian petroleums, exist naturally in the oils or are formed in the process of distillation. The results show that the aromatic hydrocarbons pre-exist in the oils.

D. Hurmuzescu †† discusses the radio-activity of Roumanian petroleums.

On January 8, 1908, the first number appeared of the *Revue du Pétrole*, a fortnightly journal edited by G. M. Murgoci, written in French, German, English, and Roumanian, and devoted to the petroleum interests of Roumania. The chief article in the first issue was written by S. Athansiu, and described the petroleum deposits of the Noamtu district, Moldavia.

Petroleum in Russia.—New investigations and discoveries of petroleum in the Western Caucasus are described by A. Yermoloff. ††

K. Charitchkoff §§ describes recent investigations of Russian petroleum.

Experiments on a large scale in the distillation of petroleum residues from Boryslaw are described by M. Wielezynski. |||

* *Mining Journal*, vol. lxxxiii. p. 5.

† *Board of Trade Journal*, vol. lix. p. 528.

‡ *Revue Universelle des Mines*, vol. xix. pp. 285-302.

§ *Banyassati es Kokassati Lapok*, vol. xl. pp. 538-542.

|| *Ibid.*, p. 584.

¶ *Ibid.*, vol. xii. pp. 166-170, 359-365.

** *Annales Scientifiques de l'Université de Jassy* (Roumania), vol. iv. pp. 192-202; *Journal of the Chemical Society*, vol. xcii. pp. 883-884.

†† *Journal du Pétrole*, vol. i. p. 218.

‡‡ *Annales des Mines*, vol. xii. pp. 511-523.

§§ *Journal du Pétrole*, vol. i. p. 222.

||| *Chemiker Zeitung*, vol. xxxi. p. 499.

M. A. Rakusin * gives the results of an investigation of petroleum from the Holy Isle, from Berekei, † and from Bibieibat. ‡ The optical properties afford indications as to the age of the deposits, and agree fairly well with the geological data, but other considerations have to be taken into account. The petroleum from Bibieibat is probably of Miocene age. It is similar to the Caucasian petroleum previously described by the author.

Petroleum in Canada.—C. W. Knight § gives an illustrated description of the new Tilbury and Romney petroleum and natural gas fields in Kent county, Ontario.

E. Coste || also describes the new Tilbury and Romney oil-fields of Kent county, Ontario.

E. Coste ¶ discusses the geology and resources of the Tilbury oil-field, Ontario. Oil was first struck in 1905, in Kent county, and large gas wells have also been encountered in the field. The oil contains 0.20 per cent. of sulphuretted hydrogen and a little sulphur, is dark green, and has a gravity of about 38.41° B. The field lies under a flat drift-covered section of the country about 600 feet above sea-level. The gas and two upper oil pays occur in the southern part of the field, in the lower brown dolomites and gypsum of the Onondaga, while the lower oil pay is struck in the upper beds of the Guelph and Niagara.

Petroleum in Queensland.—It is stated ** that crude petroleum, a heavy black oil, has been found in a well less than 100 feet in depth, within two miles of Boonah. On a farm five miles from that town a bore is said to show a volatile oil, probably kerosene, at 130 feet. The water there is impregnated with oil, which forms a heavy film on the surface of water pumped into a reservoir. There are said to be other indications of oil in several parts of the district, notably at Harrisville.

Petroleum in South Africa.—C. Sandberg †† discusses the prospects of finding petroleum in South Africa, and shows that they are favourable. He explains the previous failures to find workable deposits.

Petroleum in the West Indies.—In a paper read before the Royal Society of Canada, R. W. Ells ‡‡ gave particulars of the geological occurrence of petroleum in Trinidad and Barbados.

* *Journal of the Russian Physical and Chemical Society*, vol. xxxix. pp. 566-573.

† *Ibid.*, pp. 574-578.

‡ *Ibid.*, pp. 802-814.

§ *Annual Report of the Bureau of Mines*, vol. xvi. pp. 92-104. Toronto.

|| *Journal of the Canadian Mining Institute*, vol. x. pp. 77-84.

¶ *Engineering and Mining Journal*, vol. lxxxiv. p. 779.

** *Queenslander; Board of Trade Journal*, vol. lx. p. 190.

†† *South African Mines*, vol. v. pp. 231, 258.

‡‡ *Ottawa Naturalist*, vol. xxiii. pp. 73-79.

Petroleum in the United States.—A. Vicaire* continues his description of the petroleum resources of the United States, with special reference to those of Texas and Louisiana. The enormous plain bordering the north of the Gulf of Mexico contains numerous seepages of petroleum of varying age and commercial importance. The topography and geology of this plain is described. Of the deposits in formations anterior to the Tertiary age, two occur in Carboniferous formations, that of Transpecos and the Henrietta petroliferous field. Other basins belong to the general geological system of the gulf. Of these that of Corsicana is the principal. It occurs in the upper Cretaceous formation which traverses Texas from the south-west to the north-east of Eagle Pass in a zone thirty-five to eighty miles in width. At Corsicana a light oil is extracted and refined on the spot. It is of high quality, and the yield now amounts to less than it did originally, having fallen from 830,000 barrels in 1900 to 370,000 barrels in 1904. The various theories which have been put forward to account for the origin of petroleum in these regions are discussed, after which the leading fields are described in detail, maps and sections of the geological formations in which the chief deposits occur accompanying the descriptions. The oldest pool is that of Spindletop. The indications of the existence of petroleum in this region, while not very striking, led, nevertheless, to trial borings in 1894. Taken to a depth of about 375 feet, they failed to tap the reservoir, which was at a considerably greater depth. Lucas, however, continued to bore, notwithstanding difficulties encountered with quicksands encountered at about 450 feet from the surface. At more than twice this depth oil was met with on January 10, 1901, the outburst occurring with sufficient force to project all the metal lining of the borehole, weighing about 6 tons, to a considerable distance, while for some days the spouter reached a height of about 50 yards. It was impossible to get it under control until the ninth day, when 70,000 barrels were obtained, about 500,000 barrels having previously been lost.

The oil was heavy and contained much sulphur. By July in the same year fourteen wells had been sunk, of which ten were producing from 10,000 to 70,000 barrels per day each, while several of the wells were destroyed by violent outbursts of gases. Before the end of the year 138 wells had been sunk at Spindletop, of which fifty-five were productive. 1902 saw the zenith of oil production in this region, and there has been a steady falling off since.

The next oil boom in Texas occurred at Sour Lake. Borings had been made in 1893, and were continued with greater activity in 1903. The first spouters were encountered in 1903, and in August of that year there were no less than 220 sinkings in operation, yielding 100,000 barrels daily. By the end of the year the pool had yielded 8,000,000 barrels, and 7,000,000 were extracted in the year following. The development of subsequent fields is traced. Oil made its appear-

* *Bulletin de la Société de l'Industrie Minière*, vol. vii. pp. 433-488.

ance in the Batson Prairie region very suddenly, and the Paraffin Oil Company of Beaumont, which operated the first spouters, paid a dividend of 3000 per cent. in respect of the first three months' working in 1904, when the total production of the region reached 10,000,000 barrels. The remaining fields, Saratoga, Humble, and Jennings, are described, and the methods employed for the extraction and refining of the oil in the various regions are given, together with details as to the chemical composition and physical properties of the oils extracted.

Petroleum in California.—R. Arnold* and R. Anderson have drawn up a preliminary report on the Santa Maria oil district, Santa Barbara county. The lightness of the oil (27° to 27° Baumé) and the great productiveness of the wells (300 to 400 barrels per day) are characteristics of the district.

Petroleum in Ohio.—W. T. Griswold† and M. J. Munn give the results of a study of the geology of the oilfields in Steubenville, Burgettstown, and Claysville quadrangles in Ohio, West Virginia, and Pennsylvania. Each quadrangle covers 227 square miles, and the conditions obtaining may be regarded as typical of the various conditions in which petroleum occurs in the Appalachian field.

Petroleum in Pennsylvania.—R. W. Stone‡ and F. G. Clapp describe the oilfields of Greene county, which have been productive continuously since 1886. Over 1300 wells have been drilled within its boundaries. In the report all the available information, including unpublished data, is summarised.

Petroleum in West Virginia.—According to F. W. Brady§ the development of the oilfield in Brooke county, West Virginia, began in 1902. The total number of wells drilled in the district is about one hundred, and their depth varies from 1500 to 1900 feet. The oil is found in the Berea sand, which is from 10 to 20 feet in thickness, and is underlaid with 2 feet or more of slate. Accurate data regarding the total output of the district is not easily obtainable, but it is known in one case that a single well produced over 16,000 dollars' worth of oil in less than one year, while in another case the wells on one farm are stated to have produced 33,000 barrels of oil in twelve months. A detailed description is given of the method and materials used in "shooting" the wells.

Petroleum in Wyoming.—C. A. Fisher|| states that several attempts have been made to obtain oil from the Cretaceous shales throughout the Bighorn basin but generally without success. Oil

* *United States Geological Survey, Bulletin* No. 317.

† *Ibid.*, No. 318.

‡ *Ibid.*, No. 304.

§ *Mines and Minerals*, vol. xxviii, pp. 187-189.

|| *United States Geological Survey, Professional Paper* No. 53, p. 59.

was found near Bonanza, but none of the boreholes put down have proved commercially successful.

Petroleum in Peru.—E. I. Dueñas * describes the occurrence of petroleum in the department of the Cuzco, at Pallpata and Pusi. The oilfields are of considerable extent.

Petroleum in the Argentine Republic.—In the course of boring for water in Comodoro Rivadavia, in the Chubut Territory, a spring of petroleum was found at a depth of 530 metres. This discovery is looked upon as most important, and experts have been sent down to report fully to the Argentine Government.†

It is stated that when oil was struck at Comodoro Rivadavia at a depth of 539 metres it came to within 5 metres of the surface. A. C. Ross ‡ states that it is estimated that the output of the well is thirty-three barrels of 159 litres of oil per day.

Petroleum in Borneo.—H. O. Jones § and H. A. Wootton discuss the composition of Borneo petroleum, which differs considerably from all other varieties. Two kinds are met with, one containing a definite paraffin and the other asphalt.

Petroleum in Corea.—It is stated || that a charter has been granted to N. Toyosaburo and two other Japanese residents in Seoul to work a petroleum deposit in Chyong-ju, in North Phyang-an Province, Corea, the area of which extends over 1,757,000 square yards. This is said to be the only petroleum yet discovered in Corea.

Petroleum Congress.—D. T. Day ¶ gives an account of the proceedings at the Third Petroleum Congress held in September 1907, at Bucharest, and of the excursions made into the Bushtenari oilfield after the meeting.

A report on the Third International Petroleum Congress held at Bucharest is also published by L. Gaster.**

Asphalt.—The occurrence of asphalt in the Val de Travers, Switzerland, is described by C. Schmidt.††

G. A. Le Roy ‡‡ describes the preparation of bitumen and asphalt by treating the products of the distillation of crude petroleum with sulphur chloride.

* *Boletín del Cuerpo de Ingenieros de Minas del Perú*, No. 58, p. 153.

† *Review of the River Plate*, Buenos Ayres; *Board of Trade Journal*, vol. lx. p. 194.

‡ *Board of Trade Journal*, vol. lx. pp. 293-294.

§ *Journal of the Chemical Society*, vol. xci. p. 1146.

|| *Board of Trade Journal*, vol. lx. p. 241.

¶ *Engineering and Mining Journal*, vol. lxxxiv. pp. 781-784.

** *Journal of the Society of Arts*, vol. lv. pp. 1132-1133.

†† *Handwörterbuch der Schweizerischen Volkswirtschaft*. Bern, 1907. (Article: "Montanindustrie.")

‡‡ *Bulletin de la Société Industrielle de Mulhouse*, 1907, p. 147.

Experiments on the dry distillation of Roumanian asphalt are described (in Roumanian and in German) by K. V. Charitschkoff.*

H. W. Wilson † states that the production of asphalt in Mexico is at present chiefly confined to the Tuxpam and Tampico districts on the Gulf of Mexico. The asphalt exported from Tampico is chiefly the residue from the oil produced by the Mexican Petroleum Company at Ebano, forty miles west of Tampico. The distillate of this crude liquid asphalt is used for fuel oil. There are stated to be hundreds of thousands of tons of asphalt in the Tampico and Tuxpam districts, that from the latter district being considered the best in the world.

W. A. T. Allen ‡ gives an account of asphalt mining in Syria. The mines are near Latakia, the celebrated tobacco region, and form part of a hill 900 feet in height called Yebel Kferie. At 216 feet the asphalt layers are found over a length of 4500 feet, and a thickness of seams of 4200 feet. The seams lie in a single compact mass estimated at 150,000,000 to 200,000,000 tons. A sample of the asphalt mined at Kferie, after being subjected to the simple firing test, proved of fairly pure quality, and the quality will doubtless improve the farther in depth it is mined. The mine itself is not a new discovery, having been surveyed a few years ago, but the survey was inadequate and failed to disclose the wealth the mine is now said to possess. An imperial firman is being sought for the construction of a light railway from the mines to Latakia, as well as for harbour works at that port for the provision of adequate shipping facilities. These works would utilise as far as possible the old Roman harbour and quays.

In a paper to which reference has already been made, R. W. Ells § gives an account of the geology and mineral resources of Trinidad and Barbados, and describes the celebrated asphalt lake and the manjak mines.

Bitumen.—The occurrence of gilsonite in Uinta county, Utah, is described.|| It exists in vertical fissures in the sandstones and shales of the Eocene Tertiary period.

Oil Shale in New South Wales.—A description has been published ¶ of the oil shale deposits of New South Wales. At Capertee the richest portion of the deposit yields 140 gallons of crude oil per ton. Over two miles of deposit have been proved, representing resources of some 7,000,000 tons of oil. A railway has been constructed to establish an outlet for the products.

Oil Shale in France.—The production of oil from bituminous shale in France is described by I. Magnin.**

* *Revue du Pétrole*, vol. i. pp. 74-75.

† *Board of Trade Journal*, vol. lx. pp. 193-194.

‡ *Egyptian Gazette; Iron and Coal Trades Review*, vol. lxxv. p. 1296.

§ *Ottawa Naturalist*, vol. xxiii. pp. 73-79.

¶ *Engineering and Mining Journal*, vol. lxxxiv. pp. 918-919.

¶ *The Times*, May 1, 1908. ** *Journal du Pétrole*, vol. viii. No. 1.

Boring for Petroleum.—The development of the Canadian boring system in the Galician oilfields is reviewed by Klebert.*

M. Coppelovici † describes a simple electro-magnetic apparatus for recording the amount of work done in boring.

Uses of Petroleum.—C. Pietrusky ‡ discusses the methods of utilising fuel oil in America.

P. Weiller § describes the applications of petroleum in metallurgy.

W. A. Steinhardt || gives an account of forges with oil firing.

Julius Frucht ¶ discusses the use of crude petroleum as a substitute for coal.

M. Porn ** discusses the advantages of oil fuel.

A. Guiselin †† gives a retrospect of the petroleum industry in 1865.

VI.—NATURAL GAS.

Natural Gas in Hungary.—The importance of the natural gases of Hungary is pointed out by J. Pfeifer. ††

Natural Gas in Russia.—An important discovery of natural gas is reported from Russia. The natural-gas district is at Surachan, within a comparatively short distance from the Baku oilfield. While natural gas was known in Russia more than 1000 years ago, it is a remarkable fact that the prolific oil developments never yielded this valuable commodity in sufficient quantity to be commercially valuable. All the operations in the field, such as drilling and pumping wells, have been accomplished with the aid of the crude oil for fuel purposes. Now many firms are said to be changing over to natural gas for steam-raising. Special pipes are being laid for its conveyance and distribution. §§

Natural Gas in Canada.—There has been considerable discussion as to utilising natural-gas fields in St. Maurice county, Canada, for lighting and heating purposes at Montreal. Three Rivers is now getting gas for manufacturing purposes from this source at 10d. per 1000 cubic feet, and it is thought that, after allowances have been made for the cost of the piping from St. Barnabe to Montreal, it will be possible to sell gas in that city at a considerably lower rate than is now being paid for it. The chief item of cost would be the laying of

* *Naphta*, vol. xv. Nos. 21, 22.

† *Revue du Pétrole*, vol. i. pp. 78-79.

‡ *Pétroleum*, vol. ii. pp. 481-503. Berlin, 1908.

§ *Ibid.*, pp. 510-514. || *Ibid.*, pp. 509-510.

¶ *Montan Zeitung*, vol. xv. pp. 45-46.

** *Revue du Pétrole*, vol. i. pp. 195-197.

†† *Ibid.*, pp. 213-218, 254-257.

‡‡ *Chemiker Zeitung*, vol. xxxii. p. 9.

§§ *Engineering*, vol. lxxxv. p. 458.

pipes ; but as natural gas does not freeze, it will be possible to lay the pipes along the surface of the ground throughout the greater portion of the distance. The main problem is the permanency of the supply, and this the Canadian Coal-Gas Company, which possesses the right to tap the country for gas and oil, proposes to assure itself of as quickly as possible. The pipe-line to Three Rivers is $13\frac{1}{2}$ miles long, and there are some 14 miles of pipes, with 500 connections, in the streets of Three Rivers, while the pipe-line to Montreal would have to be 90 miles long. The price of 10d. to 1s. 3d. per 1000 cubic feet at Three Rivers is small compared with the 4s. 2d. and 5s. 3d. per 1000 cubic feet now being paid at Montreal.*

Natural Gas in the United States.—The production of natural gas in the United States in 1906 amounted to 388,842,562,000 cubic feet, measured at the atmospheric pressure, or 9,396,963 net tons. The value of the output was 46,873,932 dollars—an increase of 5,311,077 dollars over 1905. The great gain in 1906, amounting in value to 12·8 per cent., was largely due to continued development in West Virginia, where the increase was more than 3,500,000 dollars, and in Ohio, which reported a gain of 1,400,000 dollars. Pennsylvania lost ground to the extent of 639,091 dollars, or 3·3 per cent., while Indiana suffered a decrease of nearly half its product, or 43·4 per cent. The Pennsylvania industries employing gas as fuel, and notably the iron and steel works, did not find their supply curtailed as the result of decreased production, for a large quantity of gas was piped from West Virginia, so that the actual consumption in Pennsylvania showed an increase of fully 10 per cent.†

Natural Gas in Pennsylvania.—R. W. Stone ‡ and F. C. Clapp have drawn up a summary of the available information on the occurrence of gas in Greene county, which since 1890 has yielded a large amount of natural gas.

W. T. Griswold § and M. J. Munn give the results of a study of the geological conditions which control the accumulation of natural gas in the central part of the Appalachian oilfields. Their report treats of conditions in Pennsylvania, West Virginia, and Ohio.

Natural Gas in Wyoming.—C. A. Fisher || describes the occurrence of natural gas in the Bighorn basin. The gas escapes in considerable quantity from alluvial sands, and probably is derived from the underlying shales of the Pierre formation.

* *Engineering*, vol. lxxxv. p. 13.

† *Ibid.*, p. 32.

‡ *United States Geological Survey, Bulletin* No. 304.

§ *Ibid.*, No. 318.

|| *Ibid.*, *Professional Paper* No. 53, p. 59.

VII.—ARTIFICIAL GAS.

Gas-producers.—The destruction of tar in gas-producers is dealt with by H. P. Bell,* who gives sectional drawings of various types of producer.

The utilisation of low-grade fuels in gas-producers is discussed by F. E. Junge,† and the conclusions are considered by W. B. Chapman, J. A. Holmes, and C. E. Lucke.

W. Heym ‡ discusses the construction of modern gas-producers.

Various types of gas-producer are described by R. Barkow.§

The historical development of the suction gas-producer is traced by L. B. Homén.||

G. M. S. Tait¶ discusses the composition of producer-gas and its influence on the performance of the suction gas-producer.

F. J. Rowan** deals with suction gas-producers. The principles and elements of construction of suction gas plants are discussed, and illustrations of designs and results of working are given.

H. A. Humphrey †† deals with the recovery of sulphate of ammonia from the wastes of the gas-producer. Illustrations are given of various plants for the recovery of by-products, and a sectional diagram showing the general arrangement of the Mond by-product recovery gas plant.

An illustrated description has been given †† of the Atkinson automatic suction gas-producer.

O. Nagel,§§ discusses the advantages of producer-gas firing, and describes gas-producers for firing water-tube boilers, a limekiln, and a reverberatory furnace.

Improvements have been made in the Schild gas reversing valve. In this form the gas is automatically and absolutely shut off during operating or reversing, and contact between the gas and the water which forms the seal is reduced to a minimum, so that hardly any steam is generated to mix with the gas.¶¶

Producer-gas for Power Purposes.—E. A. Harvey ¶¶¶ deals with the use of producer-gas from bituminous coal, and describes, amongst others, the Loomis-Pettibone plant, and the plant designed by R. D.

* *Engineering*, vol. lxxxv. pp. 141-144, 171-173.

† *Proceedings of the American Society of Mechanical Engineers*, vol. xxviii. pp. 771-843; *Iron Trade Review*, vol. xli. pp. 967-973.

‡ *Gasmotorentchnik; Elektrotechnik und Maschinenbau*, vol. xxvi. p. 206.

§ *Zeitschrift für Dampfkessel und Maschinenbetrieb*, 1907, pp. 483-484, 534-535; 1908, pp. 61-62, 91-92.

|| *Teknisk Förening i Finland Förhandlingar*, 1908, pp. 1-7.

¶ *Cassier's Magazine*, vol. xxxiii. pp. 142-146.

** *Ibid.*, pp. 175-198.

†† *Ibid.*, pp. 55-67.

‡‡ *Iron Trade Review*, vol. xli. pp. 1042-1043.

§§ *Cassier's Magazine*, vol. xxxiii. pp. 462-468.

¶¶ *Iron Age*, vol. lxxx. pp. 240-241.

¶¶¶ *Cassier's Magazine*, vol. xxxiii. pp. 199-209.

Wood & Company, of Philadelphia. The former was the first apparatus designed for the purpose of obtaining gas from bituminous coal.

The utilisation of low-grade fuels in gas-producers is dealt with by C. T. Wilkinson.* The author has examined the results of the researches conducted by the United States Geological Survey with the object of showing the extent to which low-grade fuels may be employed in the generation of power gas, and gives the data of tests upon five low-grade fuels in comparison with high-grade steam coal.

O. Nagel † gives illustrations of dust collectors, tar extractors, and ammonia absorbers.

Gas-producers for the production of gas for gas-engines are described by H. Hirschtaff. ‡

M. P. Cleghorn § gives the results of experiments with power gas.

H. Procter Smith || gives factors to enable engineers to obtain, from a chemical analysis of producer gas, the heat and power values.

The successful demonstration at the United States government testing-plant that bituminous coals, lignites, and peats can be utilised with great economy in gas-producer plants has aroused great interest, and unbiassed information on the subject is supplied by R. L. Fernald ¶ in a paper on the present status of the producer-gas power plant in the United States.

An illustrated description has appeared ** of the by-product recovery plant designed by the Gas Power and By-products Company, Limited, Glasgow. Two plants are now at work, each capable of gasifying about 250 tons of fuel per day, and three more installations are in course of erection. Experiments on a large scale have been actively pursued for some time back, and the new plant solves the problem of combining the recovery of the by-products with the production of producer-gas in every way suitable for furnace work. The ammonia recovered is equal in value to the whole of the gas used.

Water-gas.—Papers on the production of water-gas have been written by H. Strache †† and by Kayser. ††

Gas-engines.—F. W. Burstall §§ gives the results of his researches on the working of gas-engines. The object of the trials was to determine how the horse-power and efficiency of the engine vary with the degree of compression used, and also to test the truth of the theoretical law in connection with the standard engine, that the

* *Cassier's Magazine*, vol. xxxiii. pp. 83-85.

† *Electrochemical and Metallurgical Industry*, vol. vi. pp. 102-104.

‡ *Braunkohlenindustrie*, vol. vi. p. 147.

§ *Iowa Engineer*, 1907, pp. 203-208.

|| *Chemical News*, vol. xcvi. p. 101.

¶ *United States Geological Survey, Bulletin No. 316*, pp. 439-459.

** *Iron and Coal Trades Review*, vol. lxxv. p. 1571.

†† *Journal für Gasbeleuchtung*, vol. l. pp. 885-889.

‡‡ *Prometheus*, 1907, pp. 137-140.

§§ Third Report to the Gas-engine Research Committee of the Institution of Mechanical Engineers.

efficiency is alone proportional to the degree of compression. The results obtained show conclusively that at one particular compression the best results were obtained. Above that pressure the efficiency fell off considerably. This is at variance with the usual belief that economy increases with compression, and is due considerably to the cooling action of the walls of the cylinder. At high compressions the density and temperature of the gas are much increased, and consequently more heat is carried away by the cooling water. The report proves that an efficiency of 43 per cent. can be obtained with a maximum pressure of 360 lbs. per square inch, and a temperature of only about 1200° to 1400° C., showing that large gas-engines can be constructed much more easily than is generally believed, as hitherto large mean pressures have been used to keep the size of the engine as small as possible.

P. R. Allen* deals with the construction and working of large gas-engines.

Recent progress in the design and construction of large gas-engines in Germany is discussed by F. E. Junge.†

Large gas-engines are described by W. H. Booth.‡

J. Zoller§ describes the gas-engines at the Bavarian Exhibition at Nuremberg in 1906. Karl Bachmann, Ansbach, exhibited a double-acting and a single-acting suction gas-engine and five petrol motors. The double-acting suction gas-engine develops 115 horse-power at 170 revolutions, the cylinder 17 inches diameter and 23½ inches stroke has water-cooled valves and piston by water entering the back crosshead through the hollow piston-rod. The bearings are provided with lubricating rings. The charge is ignited magnetically. The 27 horse-power single-acting engine is of very compact design, and the petrol motors are very similar. The engines are regulated by closing the inlet-valve with the exhaust open. The suction gas-producer is provided with an evaporator to which water flows from a heater heated by the exhaust gases. The gas is wasted in a coke scrubber and a dry purifier. J. W. Engelhardt & Co., Fürth, exhibited two Lüderitz engines of 40 and 25 horse-power. These are vertical A-frame engines, and their characteristic feature is the peculiar arrangement of the mixing-valve and of the regulation. The first gives a constant composition of the mixture by using an annular stream of gas surrounded by a stream of air. Brown-coal briquettes, which are charged through a hopper, are used as fuel in the Lüderitz producer. The gas is drawn off from below, and the vapours of tar are decomposed over the incandescent fuel.

The Güldner Motoren Gesellschaft, Munich, exhibited a 150 and 15 horse-power plant. The former is coupled to a Siemens-Schuckert dynamo. The 15 horse-power motor drives a compressor. Both

* Paper read before the Manchester Association of Engineers, January 11, 1906; *Mechanical Engineer*, vol. xxi. pp. 103-106, 147-150.

† *Cassier's Magazine*, vol. xxxiii. pp. 86-97.

‡ *Ibid.*, pp. 156-173.

§ *Mitteilungen des k. k. Technologischen Gewerbe-Museums in Wien*, vol. xvii. pp. 100-129.

engines are vertical, and the cylinders can expand independently from the jacket. The suction gas plant consists of a producer with anthracite as fuel and a purifier. The feed water is heated to boiling point by the producer-gas, the steam formed is superheated and then allowed to enter the evaporator; in the same manner the air is heated and mixed with the tar vapours.

Scharrer & Gross, Nuremberg, exhibited a 50 horse-power horizontal gas-engine. The cylinder and water-jacket form a single casting. The cylinder is provided with an interchangeable lining, and the piston is very long. The engine is started by compressed air. The suction-gas plant is provided with a preliminary and an after evaporator. A gas collector separates the suspended water. Before starting wood is burned on the grate, and then coal is added and the doors closed. The fire is blown with a fan until a test flame burns with a bronze yellow colour.

The Maschinenfabrik Augsburg und Maschinenbau Gesellschaft Nürnberg, A.G., exhibited a 70 and a 700 horse-power gas-engine, both arranged for suction-gas. The 700 horse-power worked with double four-cycle, and the design was a model of larger engines. The consumption of heat per horse-power and per hour amounted to from 2200 to 2400 calories, the consumption of water $15\frac{1}{2}$ gallons. This firm builds engines of this type up to 4000 horse-power, and has already constructed more than 200,000 horse-power. 150,000 horse-power are for ironworks, 28,000 horse-power for coke-ovens, and the remainder for electrical central stations. The gas-producer burned brown-coal briquettes and supplied gas for 800 horse-power. Differing from other plants, the gas is drawn off at half the height of the incandescent column of fuel, whereby the so-called inverted combustion takes place. This producer possesses no evaporator, because the briquettes contain sufficient water. When the fuel contains sulphur this is removed with limonite. Heating up lasts from one half to a whole day, then the engine can stop for a considerable time. On starting, a short blowing of the fan suffices.

F. Körmann * discusses at length the recovery of by-products from the producer, and describes the construction and theoretical output of the gas-engine at the Mansfeld mine. The ammonia water is treated in a Feldmann and Otto Ruppert column apparatus.

An illustrated description is given of the Rathbun vertical gas-engine.†

VIII.—COAL-MINING.

Underground Temperature.—M. Durnerin † gives particulars of the temperatures observed in the boreholes put down in Meurthe-et-Moselle.

* *Bergbau*, vol. xx. Nos. 50, 51, 52. † *Industrial World*, vol. xli. pp. 1494-1496.
 ‡ *Comptes Rendus Mensuels de la Société de l'Industrie Minière*, 1907, pp. 291-301.

Search for Coal.—R. Kirkby * describes the putting down of an underground diamond borehole at Prestonlinks colliery on the Firth of Forth. The borehole was 601 feet deep, and the work occupied 113 days. The plant was driven by a petrol engine.

Shaft-sinking.—On February 18, J. J. Prest read before the Institution of Civil Engineers a paper describing an achievement in mining engineering, the shaft-sinking at the Horden colliery, south-east Durham. The work was of exceptional difficulty owing to the large volumes of water encountered in sinking through the magnesian limestone and sands of Permian age. In view of possible legislative interference with the hours of underground labour, it was decided to sink three shafts, two 20 feet and one 17 feet in finished diameter. The north shaft was begun on November 6, 1900, and was finished at a depth of 419 yards on July 23, 1904. The south shaft was begun on February 28, 1901, and was finished at a depth of 302 yards on September 1, 1905. The east shaft, 17 feet in diameter, was begun on September 3, 1900, and was finished at a depth of 406 yards on November 6, 1905. The maximum feeders of water pumped simultaneously at any one period amounted to 9230 gallons per minute, from the east and south shafts, from September 23 to November 26, 1903. The production of coal from this colliery is now averaging a million tons per annum.

Henry Louis † describes a locking hook for sinking purposes. A similar device in which a sliding ferrule was used, was described by H. W. Hughes. ‡

The strength of cast-iron tubbing for deep shafts is dealt with from a mathematical standpoint by John Morrow. §

L. Morin || describes the application of the cement process in sinking through quicksand at the Liévin colliery. The cost is 900 to 1100 francs per metre, as against 2300 francs per metre for the freezing process.

A new shaft is being sunk at the Wellesley colliery, Fifeshire. ¶ It will be 270 fathoms deep, and elliptical in shape, 27½ feet by 14 feet 10 inches. The cages are double-decked, carrying eight trucks, a total load of 4 tons of coal per lift. The section is a novelty in Scotland, where rectangular shafts are usual.

S. F. Walker ** deals with the care of the plant in shaft-sinking by refrigeration, the causes of interruptions in the operation of the system, and the methods of preventing and correcting them. The subjects he discusses include the arrangement of the thermometers, condition of the brine, faults in the compressing system, the heating of the compressor, and troubles caused by deposits.

* *Transactions of the Institution of Mining Engineers*, vol. xxxv. pp. 89-92.

† *Ibid.*, vol. xxxiv. pp. 56, 58.

‡ *Ibid.*, pp. 56-57.

§ *Ibid.*, pp. 100-123.

|| *Annales des Mines*, vol. xii. pp. 493-508.

¶ *Times Engineering Supplement*, April 8, 1908.

** *Engineering and Mining Journal*, vol. lxxxiv. pp. 777-779.

Explosives in Collieries.—W. Walker * gives some notes on two instances of charges of Nobel carbonite being ignited instead of being detonated at the West Riding collieries.

J. Bolle † discusses the influence of the density of charging in trials of explosives.

A liquid air safety explosive in which aluminium replaces carbon and carbon compounds is described. ‡

James Ashworth § opens a discussion whether blasting can be continued with safety in a fiery mine.

Experiments made in Austria show that a vacuum resulting from a blown-out shot may amount to as much as $\frac{1}{2}$ inch of mercury, which is equivalent to 8 lb. to 9 lb. to the square foot. This reduction of pressure creates an increase in the flow of fire-damp in the ratio of 235 to 100. Under the conditions stated blown-out shots may furnish a considerable amount of gas that would not be driven from the coal under ordinary conditions.

Safety explosives are described by K. Selbach. || Missfires with safety explosives are discussed by Dautriche, ¶ and the premature explosion of charges by G. Zachmann. **

Coal-wedge.—Results are given †† of trials of a new coal-wedge patented by König and Gützlaff. The trials were made at the Reden colliery, and the results indicate that a useful means has been found for lessening the amount of blasting necessary.

Electricity in Collieries.—The application of electricity in coal-mining is discussed. ‡‡

Recent improvements in the design of electric cables for collieries are reviewed by G. G. L. Preece. §§

The importance of gas-tight switches in mining work is urged by W. B. Shaw. ||||

An illustrated description has appeared of the electrically-operated winding plant of the Axwell Park Colliery, Durham. ¶¶ The shaft is 252½ feet deep, and is used mainly for the workmen, most of the coal being brought out through a drift. In order to avoid large fluctuations in the current taken from the supply, it was decided to adopt the Ilgner system. The total maximum weight to be raised is 6700 lbs., the cage weighing 3200 lbs., and the men 3500 lbs. A balance weight is provided approximately equal to the weight of the cage plus half

* *Transactions of the Institution of Mining Engineers*, vol. xxxiv. pp. 215-220.

† *Annales des Mines de Belgique*, vol. xiii. pp. 33-51.

‡ *Revue des Produits Chimiques*, October 15, 1907.

§ *Proceedings of the South Wales Institute of Engineers*, vol. xxv. pp. 612-619.

|| *Oesterreichische Zeitschrift für Berg- und Hüttenwesen*, vol. lv. pp. 622, 637.

¶ *Annales des Mines*, vol. xii. pp. 141-165.

** *Zeitschrift für Schiess- und Sprengstoffwesen*, vol. i. p. 443.

†† *Glückauf*, vol. xlili. pp. 1429-1432.

‡‡ *Cassier's Magazine*, vol. xxxiii. pp. 356-371.

§§ *Transactions of the Institution of Mining Engineers*, vol. xxxiv. pp. 161-168.

||| *Electrical Review*, vol. lxii. pp. 196-197.

¶¶ *Iron and Coal Trades Review*, vol. lxxvi. pp. 519-520.

the weight of the men. The time allowed for a complete cycle is 55 seconds in round figures, and of this time 12 seconds are taken up for acceleration, followed by 23 seconds of full speed run, and 5 seconds for retardation, the remaining 15 seconds being sufficient to allow the men to enter or leave. The full speed is 8 feet per second. The Ilgner converter set consists of a three-phase motor on one side of the fly-wheel, and a continuous-current motor mounted on the other side.

Compressed Air at Collieries.—An illustrated description has appeared* of an air-compressor of 1200 horse-power built for the Londonderry Collieries, Limited, for supplying air for the underground haulage at the Seaham colliery. The compressor has two air cylinders each 32 inches in diameter by 72 inches stroke, driven by a cross compound-condensing steam-engine having a high-pressure cylinder 30 inches in diameter and a low-pressure cylinder 52 inches in diameter, each with 72 inches stroke. The compressor is arranged to run at sixty-five revolutions per minute, and has a free-air capacity of 8600 cubic feet per minute of 70 lbs. pressure.

J. S. Haldane† describes the peculiar physiological troubles and dangers to health associated with work in compressed air.

Coal-cutting Machinery.—O. Jüngst‡ gives the results obtained with mechanical coal-cutters at the Government collieries at Saarbrücken from July 1, 1906, to June 30, 1907. The economy effected compared with hand-labour varies from 4·1 to 15·4 per cent. with the different machines.

Mine Supports.—P. Hecker§ describes some recent improvements in mine supports, iron props with wedges, elastic iron props, and sharpened wooden props with wedged lids.

D. Stens|| describes the methods of timber impregnation used at the collieries of the Mülheim Mining Company.

E. M. Weston¶ describes the timbering used in the shafts of the Rand collieries. The timber used is stringybark from Tasmania, and an approximate method of framing the timbers is used, because side-pressure and rapid winding soon displace them.

In view of the fact that the life of timber in mines is so short, experiments have been made in the deeper mines of the anthracite region in the United States in order to find some permanent form of installation. Up to the present time it has been found that steel is the only class of material which, by its flexibility and convenience of use, can replace wooden construction fully and satisfactorily. The first use of steel in mines in the United States appears to have been

* *Colliery Guardian*, vol. xciv. pp. 1146-1147.

† *Journal of the Society of Arts*, vol. lvi. pp. 214-226.

‡ *Glückauf*, vol. xlv. pp. 42-44.

§ *Ibid.*, pp. 553-562.

|| *Ibid.*, vol. xliii. pp. 1757-1759; *Bergbau*, vol. xx. Nos. 64, 65.

¶ *Engineering and Mining Journal*, pp. 551-552.

made by the Susquehanna Coal Company, and there is in use at the present time in the anthracite regions steel supports that have been in use from twelve to fifteen years in the deep parts of the mines, exposed to constant contact with mine water, without showing signs of failure or corrosion. Beyond its long life, other advantages of steel supports are that it can be cut to length and fashioned in convenient units ready for erection, and its smaller weight lends itself to convenience and economy in erection. It can also be easily removed after operations in any particular locality are completed, and repeatedly re-used. Illustrations are given * of recommended forms of construction.

Steel struts and beams for lining tunnels have been used for twelve to fifteen years by the Susquehanna Coal Company in Pennsylvania. The consulting engineer of that company, R. V. Norris, designed a form of gangway support, consisting of posts of channels, with an I-beam cap. The members are put together with pins and wedges, and the posts rest on cast iron bases, which enable the whole construction to be taken down or to be adjusted very quickly. Some of these frames have been exposed to constant contact with mine water, but they show little sign of corrosion, although the only protection given them has been a good heavy coat of paint from time to time.†

R. B. Woodworth,‡ in a report on an investigation of the conditions of mine timbering in the anthracite region of Pennsylvania, advocates the substitution of steel for timber in mines.

M. S. Hachita§ discusses the use of steel beams for supporting the roofs in coal-mines.

Methods of Working.—W. Charlton|| gives a detailed description of some of the methods of mining the thick coal of South Staffordshire.

H. S. Gay¶ describes a single-room system of mining, an adaptation of the longwall method to work in thick seams. It is in operation in West Virginia.

O. Dobbelstein** describes the flushing process of stowing the old workings used at the Katharina colliery.

An account is published †† of the water-flushing method of stowing old workings as applied at the Consolidation colliery at Schalke.

E. Bodifée ‡‡ discusses the methods used in the Saar coalfield for clarifying the water used for the flushing method of stowing old workings. He finds that the best method is to conduct the water from the

* *Industrial World*, vol. xli. pp. 1314-1316.

† *Engineer*, vol. civ. p. 543.

‡ *Mines and Minerals*, vol. xxviii. pp. 212-215.

§ *Engineering and Mining Journal*, vol. lxxxiv. pp. 1169-1172.

|| Paper read before the North Staffordshire Institute of Mining and Mechanical Engineers, December 9, 1907; *Colliery Guardian*, vol. xciv. pp. 1098-1099.

¶ *Transactions of the Institution of Mining Engineers*, vol. xxxiii. pp. 558-566.

** *Glückauf*, vol. xlv. pp. 145-152.

†† *Ibid.*, vol. xliii. pp. 1649-1650.

‡‡ *Ibid.*, pp. 1753-1755.

workings to a small sump in which the greater portion of the sand is deposited.

A detailed description has been published of the flushing method employed at the Deutscher Kaiser colliery at Hamborn.*

A. Heil † gives data concerning the life of cast-iron piping used for flushing down material from the surface for packing the mine workings at one of the large collieries in Silesia.

H. Grahn ‡ deals with the work of divers in mining. At the Bochum mining school, where he is lecturer, the students are trained in diving operations.

C. Kleinschmidt § describes a visit to some collieries in Belgium, Northern France, and England. The British collieries dealt with are the Bargoed colliery, Garth colliery, Hulton colliery, Diamond and Silkstone colliery, and Cadeby colliery.

A. Hochstrate || describes the equipment of the De Wendel colliery at Herringen, near Hamm, in Westphalia. The output at the present time is 600 tons a day.

V. Alimanestianu ¶ describes the methods of working the Roumanian lignite deposits.

J. White ** deals with the economical working of collieries in Bengal, dealing especially with the waste in hewing, handling, coking, and transport.

The Dandot coal-mine of India †† has a system of timbering that compares favourably with any other system used in any country. The seam is from 2 feet to 3 feet thick, and is worked by the longwall method. Wooden chocks, 2 feet square, are built at a distance of 4 feet 6 inches apart, measuring from centre to centre. Props are set in advance the same distance apart, and these form centres for the chocks as the work progresses. Planks 1½ inches thick and 6 inches wide are set above the chocks and props and kept close to the face. Thus the miners are always protected by timber when working. The timber is set by specially-appointed men.

H. Louis †† has translated a paper by P. Sainte-Claire-Deville on a simple method of water stowage employed at No. 5 pit of the Escarpelle mines.

A large number of coal-beds are being worked in parts of the United States within comparatively few feet of the surface. Such beds exist in Pennsylvania, Illinois, &c., and in many cases the use of the steam-shovel is resorted to for stripping the overburden of soil, &c., in order to get at the coal, which is then worked in open quarries. The

* *Glückauf*, vol. xliii. pp. 1461-1468.

† *Zeitschrift des Oberschlesischen Berg- und Hüttenmännischen Vereins*, vol. xvi. p. 309; *Bergbau*, vol. xx., No. 57.

‡ *Glückauf*, vol. xliiv. pp. 344-351.

§ *Ibid.*, pp. 152-159.

|| *Ibid.*, pp. 37-42, 73-84.

¶ *Revue Universelle des Mines*, vol. xx. pp. 48-64.

** *Transactions of the Mining and Geological Institute of India*, vol. ii. pp. 71-81. 85-95.

†† *Engineering and Mining Journal*, vol. lxxxiv. p. 1126.

‡‡ *Transactions of the Institution of Mining Engineers*, vol. xxxv. pp. 79-85.

ordinary steam-shovel has no means of disposing of the earth it works except by putting it into tipping waggons, but a plant has been put into operation at Danville, Illinois, which at once strips the overburden, and disposes of it at such a distance as not to interfere with the mining operations. The plant consists of a combined steam-shovel and conveyor. The wagon platform is 30 feet wide by 56 feet long, and is mounted on four trucks. The shovel is of 2 cubic yards capacity, and the soil stripped is dropped from the shovel into a large steel hopper at one side, and near the front of the machine. From this hopper the material is carried to a smaller hopper 12 feet distant at the lower end of a belt-conveyor 105 feet long. This conveyor, which delivers out to one side, is supported from a tower rising to a height of 48 feet above the deck. The belt is of 40 inches width, and the conveyor can be worked with its out-board end at a height sufficient to deliver material 60 feet above the tracks. The conveyor-feeder and the conveyor are driven by an 8-inch by 10-inch single cylinder engine. Steam is provided by a locomotive boiler working at 125 lb. pressure. This plant is employed at Danville in stripping overburden of a depth of 38 feet to 40 feet overlying an 8 feet seam of coal.*

M. S. Hachita † describes the methods employed in the anthracite mines at Alden, Pennsylvania.

The progress of development of the coal-mining industry of the United States, and the improvement in mining methods effected during the year 1907, are described by F. W. Parsons. ‡

The methods of mining employed in the Kanawha New River and Pocohontas coalfields of West Virginia are described by F. W. Parsons.§

A. T. Shurick || describes the methods of working employed in the Diamondville coalfield, Wyoming, where practically all the coal is mined on the rise and the tubs reach the face by self-acting planes.

The methods of working the coal-measures of Carbon county, Montana, and the plant and appliances at the mines of the Northern Pacific Railroad Company at Red Lodge, Montana, are described and illustrated by F. W. Parsons. ¶

M. S. Hachita ** describes the methods of mining employed in the anthracite mines of the Wyoming valley, and the employment of steel beams to support the roof, the advantages of which more than counter-balance their greater cost.

C. Gruhl †† describes the successful application of an electrically driven excavator in working brown-coal at the Bleibtreu mine, East Cologne district.

* *Engineering*, vol. lxxxv. p. 11.

† *Engineering and Mining Journal*, vol. lxxxiv. pp. 1216-1219.

‡ *Ibid.*, vol. lxxxv. pp. 70-73.

§ *Ibid.*, vol. lxxxiv. pp. 881-885.

|| *Ibid.*, vol. lxxxv. pp. 116-118.

¶ *Ibid.*, lxxxiv. pp. 1071-1074.

** *Ibid.*, pp. 1169-1172.

†† *Braunkohle*, vol. vi. p. 517; *Zeitschrift für das Berg-, Hütten- und Salinenwesen*, vol. lvi. pp. 131-135.

The progress of mining and the adoption of scientific methods to mining operations are discussed by H. Briggs.*

Underground Haulage.—T. C. Futers,† in a lengthy series of articles on the mechanical engineering of collieries, deals with underground haulage.

J. Searston ‡ discusses the advantages to be derived from opening out a colliery by three main roads.

J. I. Thomas § summarises recent progress in methods of haulage, with special reference to the employment of mechanical conveyors in longwall mining.

The M'Ginty system of haulage, employed at the collieries of the Kemmerer Coal Company, Wyoming, is illustrated and described by F. W. Parsons.||

F. Norman,¶ in discussing the advantages of electric haulage, compares the different methods of haulage in use, and deals with the conditions favourable to each.

According to Joerchel,** miners are transported at the Königin Luise mine, Upper Silesia, by petrol locomotives hauling five passenger trucks, each carrying eight men, along the northern heading, 1500 yards in length, at the beginning and end of the shift.

An illustrated description has appeared †† of the Jeffrey electric mine locomotive intended for gathering loaded tubs from the working faces and distributing empty ones in their place. The distinctive feature of the locomotive is that it may be operated over tracks where there are neither trolley wires nor steel rails by carrying upon the locomotive a reel of flexible, insulated conductor. When it is desired to run on tracks where there is no trolley wire the cable is connected to the trolley wire, and the locomotive is propelled by current taken through the cable. The cable is automatically paid out as the locomotive runs away from the connection to the trolley wire, and automatically re-wound in even layers and with uniform tension upon the reel, when the locomotive returns.

F. Freise †† gives a history of underground haulage up to the middle of the nineteenth century.

Eye-diseases in mine horses are dealt with by Sturm.§§

Winding-engines.—Drawings have been published |||| of a pair of winding-engines for the Nine-Mile Point colliery, South Wales.

* *Iron and Coal Trades Review*, vol. lxxvi. pp. 335-336.

† *Colliery Guardian*, vol. xciv. p. 1191; vol. xc. pp. 33, 85, 121, 166, 225, 259 *et seq.*

‡ Paper read before the National Association of Colliery Managers, November 9, 1907; *Iron and Coal Trades Review*, vol. lxxv. pp. 1861-1862.

§ *Mines and Minerals*, vol. xxviii. pp. 200-203.

|| *Engineering and Mining Journal*, vol. lxxxv. pp. 118-120.

¶ *Mines and Minerals*, vol. xxviii. pp. 383-384.

** *Zeitschrift des Oberschlesischen Berg- und Hüttenmännischen Vereins*, vol. xlv. pp. 531-533.

†† *Iron and Coal Trades Review*, vol. lxxv. p. 1385.

‡‡ *Berg- und Hüttenmännische Rundschau*, vol. iii. pp. 310, 327.

§§ *Kohle und Erz*, 1907, pp. 1041-1044. |||| *Engineering*, vol. lxxxv. p. 75.

They are of the coupled high-pressure type, with cylinders 36 inches in diameter and a stroke of 72 inches.

L. Becker * deals with the mechanical and electrical losses in the flywheel motor-generator set in the Ilgner system. These losses continue during the whole time the plant is at work and the actual winding is intermittent, they therefore represent a considerable percentage of the energy consumed. A further disadvantage of the Ilgner system relates to its high capital cost as compared with steam winding. The high peripheral speeds of from 80 to 100 metres per second are associated with considerable air-friction losses, which are considerably greater than the bearing losses. The losses are much greater than the bearing losses. The air-friction losses have been reduced in certain cases about 30 per cent. by encasing the flywheel. A further reduction has been experimentally made by exhausting the air from the casing. The total losses in seven different designs of Ilgner plant are examined, and the air-friction loss of the flywheel and of the machines composing the motor-generator set amounts to from 7 to 10 per cent. of the output of the motor. The mechanical losses are about one-third and the electrical losses about two-thirds of the total losses. In newer designs of Ilgner flywheel motor-generator sets the efficiencies vary from 75 to 82 per cent. The steam consumption of the electric winding plant ranges from 10 to 14 kilogrammes per horse-power per hour, which in spite of the high capital cost is a striking contrast to the steam consumption of from 40 to 50 kilogrammes per horse-power per hour for steam winding.

The new winding-engines installed by the Ruabon Coal and Coke Company, Limited, Ruabon, North Wales, are described.† They are coupled, horizontal, non-condensing Corliss engines, with cylinders 36 inches diameter by 6 feet stroke. The soleplates are of massive design, of the mammoth and trunk type. The drum is 18 feet diameter by 5 feet 8 inches wide, built with cast iron cheeks and centre stiffening rings, and covered with steel plate cleading $\frac{3}{4}$ inch thick.

Illustrated descriptions have appeared ‡ of an electrical winding plant at the Axwell Park colliery, County Durham.

Problems connected with the electric driving of winding-engines are discussed by E. Kulka.§

Winding Appliances.—T. H. Ward|| describes a rapid cage changing device consisting of a trolley which is run across the mouth of the shaft to enable a cage to be changed or to be substituted by a water-barrel. He also ¶ describes rope cappings.

* *Elektrische Kraftbetrieb und Bahnen*, vol. v. pp. 485-493, 508-513, 528-532; *Glückauf*, vol. xliv. pp. 189-193.

† *Iron and Coal Trades Review*, vol. lxxv. p. 739.

‡ *Syren and Shipping*, vol. xlv. pp. 6-7.

§ *Elektrotechnische Zeitschrift*, vol. xxviii. pp. 1185-1187.

|| *Transactions of the Mining and Geological Institute of India*, vol. i. pp. 209-212.

¶ *Ibid.*, pp. 213-215.

R. A. S. Redmayne * has reported on the shaft accidents at Foggs colliery, October 4, 1907, at Barrow colliery, November 15, 1907, and at Rawdon colliery, November 18, 1907. He is of opinion that it would be advisable to substitute chains for rigid rods for suspending cages, and to have such chains annealed every six months.

K. Schreiber † discusses the change in weight of a cage in descent.

J. S. Barnes ‡ discusses the design of pit-bottom arches, and the relative advantages of making pit-bottom mouthings coned, or bell mouthed. He also discusses § the arrangement of cage guides for modern collieries.

Winding-ropes.—W. Routledge || gives the results of some tests of winding-ropes and capels.

Pit-head Frames.—H. Clark ¶ discusses the recent improvements which have been made in the design and construction of pit-head frames and gear. Advocates of lattice headgear point out that joist headgear, while meeting all practical purposes, is not scientifically correct. The most efficient strut is one where the sectional area is situated farthest away from its centre of gravity, and it will be seen that in the joist type of headgear there is frequently a heavy web in the joist on the centre of gravity, whereas, in the lattice type, the section is embodied in the four angle irons situated at the extreme corners. On the other hand joist headgear is slightly cheaper.

Mine Drainage.—A. Thimm ** describes some new installations of Sulzer high-lift centrifugal pumps in the Ruhr coalfield. High-lift centrifugal pumps for mine drainage are also described by A. Genart. ††

The University of Wisconsin has issued a pamphlet which contains the results of a long series of investigations carried out at the University into the working of centrifugal pumps. This bulletin deals with the effect on discharge and efficiency of the number and shape of vanes of the impeller.

An illustrated description has appeared †† of an electrically-driven three-throw ram pump. These pumps, a second set of which have been installed at the Hebburn colliery, County Durham, are 12½ inches in diameter by 18 inches stroke, and are capable of pumping 36,000 gallons per hour against a head pressure of 1100 feet. An electric two-throw pump and motor for operation in one of the mines of the

* *Home Office Report*, 1908 [Cd. 3979].

† *Glückauf*, vol. xliii. pp. 1468-1470.

‡ *Iron and Coal Trades Review*, vol. lxxvi. pp. 140-142.

§ *Ibid.*, vol. lxxv. pp. 1299-1301.

|| *Transactions of the Institution of Mining Engineers*, vol. xxxiv. pp. 140-148.

¶ Paper read before the National Association of Colliery Managers, January 18, 1906; *Iron and Coal Trades Review*, vol. lxxvi. pp. 337-338.

** *Glückauf*, vol. xlv. pp. 181-189.

†† *Revue Universelle des Mines*, vol. xx. p. 133.

‡‡ *Colliery Guardian*, vol. xciv. p. 122.

Compania Minera "El Salobral," Cadiz, is also described. The pump and motor was designed to go down a drift 2 feet, the incline of the drift being 45 feet with the horizontal. The pump, the extreme width of which over the crank shaft pins is 1 foot 11 $\frac{1}{2}$ inches, was specially designed with this stipulation in view. The capacity of the pump is 91 gallons against a total head pressure of 500 feet.

Papers on pumping and drainage by Daniel Davies,* and by G. J. Fisher,† awarded prizes in the competition instituted by Sir W. T. Lewis, Bart., have been published in full.

Mine Ventilation.—The results are given ‡ of tests of a new fan at the Friedrich der Grosse colliery at Herne. The fan is of the exhausting type, with vanes 4500 millimetres in diameter, and on the axis is a Brown Boveri alternating current motor. The results of the test were eminently satisfactory.

K. Kegel § discusses the influence of the natural ventilating current on the mechanical efficiency of fans. The subject is dealt with from a mathematical point of view.

K. Kegel || also deals with the production of ventilating currents for deep mines.

Gases in Mines.—H. E. Gray ¶ discusses the various gases found in coal-mines, their methods of identification, and the means to be adopted for the prevention of accidents.

F. Clowes ** deals with the chemical composition and characters of coal-mine gases.

R. Jordan †† gives some notes on the occurrence in coal-mines of hidden cavities, containing firedamp, in the strata overlying and underlying the goaf in near proximity to the working face, such cavities having been formed by the extraction of the coal.

Clarence Hall †† describes the apparatus for testing explosive mixtures of gas, air, and dust, and safety-lamps that is to be installed in the testing station of the Technologic Division of the United States Geological Survey. An outline of the proposed work of this testing station is also given, together with plans of some of the apparatus.

Colliery Explosions.—The Report of the Commission on the means employed for the rescue of miners at the Courrières mines, after the explosion of March 10, 1906, has been issued.§§ The Com-

* *Proceedings of the South Wales Institute of Engineers*, vol. xxv. pp. 549-568.

† *Ibid.*, pp. 589-611.

‡ *Glückauf*, vol. xliii. pp. 1755-1757.

§ *Ibid.*, vol. xliv. pp. 118-124.

|| *Ibid.*, vol. xliii. pp. 1530-1533; *Bergbau*, vol. xx., No. 58.

¶ *Engineering and Mining Journal*, vol. lxxxiv. pp. 787-789.

** Lecture before the National Association of Colliery Managers, Nottingham, October 26, 1907; *Iron and Coal Trades Review*, vol. lxxv. pp. 1756-1757.

†† *Proceedings of the South Wales Institute of Engineers*, vol. xxv. pp. 496-504.

‡‡ *Mines and Minerals*, vol. xxviii. pp. 196-197.

§§ *Bulletin de la Société de l'Industrie Minière*, vol. vii. pp. 553-600.

missioners issue the following figures relative to the number of workmen involved: 1780 men descended the pits on the morning of the 10th. After the explosion 670 were hauled to the surface the same day by shafts 10 and 11; 13 were rescued on the 30th after being imprisoned twenty days, and 1 was rescued on April 4, making 684 in all. The number of victims was therefore 1096. The Commission deals with the alleged errors of judgment made by the engineers in assuming that all those remaining in the mine had perished, but exonerate them of all charges of negligence, and confirm the wisdom of the course they pursued.

A translation has been published* of the official report on the Courrières disaster of March 10, 1906.

A report on the circumstances attending an explosion of coal dust which occurred at Dinas Main colliery on December 14, 1907, has been drawn up by W. N. Atkinson † and J. Dyer Lewis.

James Ashworth ‡ expresses the opinion that the Courrières disaster was only to a certain extent a coal-dust explosion, and that many of the effects were due to air percussion and not to actual flame.

J. Ashworth § discusses the advantages of watering the roads in mines in order to allay dust and thus obviate danger from explosions, but concludes that watering alone is insufficient for the purposes in view.

S. Stassart || and J. Bolle have published a report on the Reden colliery explosion.

The causes which led to the disastrous explosion at the Monongah coal-mines, West Virginia, in December 1907, are discussed by F. W. Parsons, ¶ who believes it to have been due to the breaking of a trolley wire at the foot of a slope, owing to a runaway train of tubs coming in contact with it. Barometric pressure did not apparently play an important part in this explosion.

H. H. Stock ** describes an explosion that occurred at the No. 6 and No. 8 mines of the Fairmont Coal Company at Monongah, West Virginia.

An explosion that occurred at the Darr mine of the Pittsburgh Coal Company, situated on the Youghiogheny River, Pennsylvania, is described. ††

C. Schulz ‡‡ and R. S. Moss deal with the prevention of colliery accidents.

A Blue-book has been issued containing further evidence given before the Royal Commission on Mines. In an appendix are some interesting tables relating to fatal accidents in mines during the period 1896 to 1905. It appears that in that decade the number of

* *Transactions of the Institution of Mining Engineers*, vol. xxxiv. pp. 468-483.

† *Home Office Report* [Cd. 4049].

‡ *Transactions of the Institution of Mining Engineers*, vol. xxxiv. pp. 270-281.

§ *Cassier's Magazine*, vol. xxxii. pp. 478-486.

|| *Annales des Mines de Belgique*, vol. xii. pp. 1039-1073.

¶ *Engineering and Mining Journal*, vol. lxxxiv. pp. 1121-1123.

** *Mines and Minerals*, vol. xxviii. pp. 277-280.

†† *Ibid.*, pp. 377-382.

‡‡ *Mining World*, vol. xxviii. pp. 247, 248.

explosions of fire-damp or coal-dust was 183, resulting in 720 deaths. In 119 of these cases the explosions were caused by the use of unprotected lights, 253 men losing their lives in consequence. During the same period the total number of deaths from all classes of accidents was 10,202. Of these, 4793 fatalities were due to falls of roof or sides, and 1828 to haulage accidents.

C. O. Hirsch* reviews the colliery accidents that have taken place in Saxony during the last forty years, showing the great improvement that has been brought about of recent years.

P. J. Slevin † considers the various causes of accidents in mines, their relative importance, and the best mode of obviating them.

F. L. Hoffmann ‡ gives a statistical account of fatal accidents in coal-mines in North America during 1906, and compares them with previous years. During 1906 the number of miners killed in coal-mines amounted to 2078, a decrease of 113 on the number of similar accidents in 1905, although the number of miners employed was greater by over 20,000 than in the previous year. The average death-rate was 3.16 per 1000. The rate was greater in Colorado than elsewhere, being 7.32, and lowest in Maryland, when it fell to 1.13. The average death-rate in 1905 was 3.44 per 1000. The influence of disciplinary measures on the number of accidents is discussed, as well as the connection between barometric pressure and mine explosions.

At the winter meeting of the Coal-Mining Institute of America at Pittsburg on December 11, C. Hall read a paper on "Statistics Relative to Mine Accidents," and F. W. Parsons contributed notes on the Monongah mine disaster.

H. Briggs § deals with the application of science to the reduction of accidents in mines. Explosions have attracted the attention of engineers and scientists to a greater degree than other catastrophes. The year 1880—the date of the Seaham explosion—may be considered the commencement of modern inquiry into the cause of explosions, as shortly after that date Abel undertook his researches. Since that date there have been many working on the subject. A diagram is given showing how, from 1880 forward, the percentage death-rate from explosions has wonderfully decreased. The names which stand out most prominently in this connection are those of Abel, Galloway, and the brothers Atkinson. There has also been a steady decrease in the number of deaths caused by falls, but the improvement in this direction is not so rapid as could be desired.

J. Neal || describes an ignition of coal-dust at Middleton colliery.

Experiments illustrative of the inflammability of mixtures of coal-dust and air are described by P. Phillips Bedson ¶ and H. Widdas.

* *Jahrbuch für das Berg- und Hüttenwesen im Königreiche Sachsen*, 1907, pp. 49-73.

† *Mines and Minerals*, vol. xxviii, pp. 121-122.

‡ *Engineering and Mining Journal*, vol. lxxxv, pp. 34-36.

§ Inaugural address, delivered on January 7th, on the occasion of the opening of the new Department of Mining in the Heriot Watt College, Edinburgh; *Iron and Coal Trades Review*, vol. lxxvi, pp. 335-336.

|| *Transactions of the Institution of Mining Engineers*, vol. xxxiv, p. pp. 221-231.

¶ *Ibid.*, pp. 91-99.

As a precaution against coal-dust explosions, William Galloway, in the course of his evidence before the Royal Commission on Mines, said that if the coal-dust in a roadway in a mine were regularly strewn, say daily, with a sufficient amount of salts containing large quantities of water of crystallisation, or with much larger proportions of the dusts of clay, slate, limestone, chalk, or other substances, it would be rendered quite as innocuous as if it were damped with water.

The Lighting of Collieries.—R. Cremer * describes the Wolf-Bohres electric safety-lamp, fitted with an Osram lamp made especially for the purpose.

The dangers of safety-lamps with lighting appliances are discussed by G. Chesneau. †

Underground Fires.—Jonathan Wroe ‡ gives some notes on a recent underground fire at Wharnccliffe Silkstone collieries, and describes the application of the Draeger apparatus in dealing with the fire. Further particulars are given by A. T. Winborn.§

Since the catastrophe at Courrières in France there has been no mining accident so terrible in its character as the disaster at Hamstead colliery. Fire broke out in the mine on March 4th, and after seven days of incessant labour the rescue party found the bodies of thirteen of the twenty-five miners entombed in the burning mine. The remaining bodies were all found by March 14th. The accident, appalling though it was, afforded a favourable opportunity of testing the efficacy of rescue appliances. A striking testimony to the value of such apparatus was the fact that M. W. Waterhouse, the manager, was able, without previous experience, to wear a Draeger helmet underground for an hour and a half. W. E. Garforth's Weg apparatus also proved efficient. In it the supply of oxygen can be regulated at will. The results of the Hamstead experience certainly bear out the view expressed by the Royal Commission on Mines that the adoption of rescue appliances is ripe for further development in this country and demands the serious attention of the coal-mining industry, although sufficient advance has not yet been made in this country to justify at present making the provision of any of these appliances compulsory.||

The methods employed in combating a dangerous fire at the Alden anthracite mines, Pennsylvania, are described by M. S. Hachita. ¶

Weise ** describes a new form of mine dam for isolating underground fires.

* *Transactions of the Institution of Mining Engineers*, vol. xxxiv. pp. 59-60.

† *Annales des Mines*, vol. xii. pp. 111-140.

‡ *Transactions of the Institution of Mining Engineers*, vol. xxxv. pp. 2-6.

§ *Ibid.*, pp. 7-22.

|| *Engineer*, vol. cv. p. 341.

¶ *Engineering and Mining Journal*, vol. lxxxiv. pp. 1217-1219.

** *Glückauf*, vol. xliii. pp. 1401-1405.

Life-saving Appliances.—Leonard Hill * deals with the physiological effects of foul air and the principles of construction of breathing apparatus, and gives a detailed description of the improved Fleuss-Siebe Gorman apparatus.

James Bain † directs attention to a report on rescue apparatus by a committee of the Fife and Clackmannan Coal-Owners' Association.

A report has been published ‡ showing the extent to which rescue appliances have been adopted in the various German colliery districts.

O. Stegemann § describes the arrangements made for organising rescue work at the collieries of the Wurm and Inde district, and R. Backwinkel || describes the application of rescue apparatus at the Laurahütte collieries in Silesia. A permanent rescue corps has been equipped.

An account is published ¶ of the installation of a central rescue station in the Donetz coalfield.

T. Schontheil ** describes an improved self-contained breathing apparatus for rescue work in mines. It is a perfected form of the original Fleuss apparatus used twenty-five years ago.

The opinion of the French Mining Commission appointed to study the subject of safety respiratory apparatus in mines is rather against them. A report published by this Commission says that it recognises that when another grave accident takes place in French mines public opinion will not understand the purely technical motives which might have influenced the Commission at the present time in proposing to the department either to withhold any interference or to defer the solution until experiments pronounced for or against the apparatus already in use or those on trial in other countries. ††

The Dominion Coal Company of Canada is organising a central rescue station for its collieries in Nova Scotia, in addition to forming rescue brigades at the various collieries themselves. Twenty sets of Draeger apparatus have been purchased—ten of the helmet and ten of the mouthpiece type. The rescue station is to consist of a large practice-room and store, where apparatus will be kept ready for immediate use, and of a lecture-hall and drill-room for the men, who assemble for practice and drill. There will also be the necessary office accommodation. It is suggested, at some future date, to add a practice-gallery, and a corps of men will be trained at each of the company's ten mines. Apparatus will also be kept at the mines. The central station is in telephonic communication with all the mines, and is in close proximity to the tramway system which runs through the mining district. ††

The Vajen-Bader head protector, for use in mine fires, is illus-

* *Transactions of the Institution of Mining Engineers*, vol. xxxv. pp. 24-45.

† *Ibid.*, vol. xxxiv. pp. 72-75.

‡ *Glückauf*, vol. xliii. pp. 1602-1608.

§ *Ibid.*, pp. 1525-1530.

|| *Ibid.*, vol. xliiv. pp. 44-48.

¶ *Ibid.*, vol. xliiii. pp. 1414-1415.

** *Proceedings of the South Wales Institute of Engineers*, vol. xxv. pp. 488-495.

†† *Engineer*, vol. cv. p. 89.

‡‡ *Engineering and Mining Journal*, vol. lxxxiv. p. 695.

trated and described by M. S. Hachita.* Fresh air, in sufficient quantity for one hour's working with the appliance, is supplied to the wearer at natural pressure by a reservoir fastened to the back of the reservoir. The apparatus weighs only six pounds, and can be recharged with air in two minutes by means of a hand-pump.

A. Gradenwitz † gives an illustrated description of the Aerolith breathing apparatus, invented by Schümann. The air supply is provided by the use of liquid air.

M. S. Hachita ‡ gives an account of the first-aid corps which have been inaugurated at all the collieries of the Lehigh Valley Coal Company.

An early form of safety breathing appliance for use in gaseous mines is noticed by E. P. Buffett § as having been described as far back as June 1752 in a British publication entitled the *Universal Magazine*.

Subsidence.—K. Kegel || discusses the connection between the drainage of porous strata and the subsidence of the surface.

History of Coal-mining.—Some notes on the history of coal-mining in Warwickshire are given by Alexander Smith. ¶

A detailed report has been published ** of the jubilee celebration of the South Wales Institute of Engineers, a society that has done much to furthering mining progress in South Wales and Monmouthshire. The report is illustrated by portraits of the presidents of the Institute since its formation, namely, W. Menelaus, first president; E. Rogers, W. S. Clark, Lionel Brough, W. Adams, T. Evans, A. Bassett, G. Martin, R. Bedlington, Sir W. T. Lewis, Bart., T. Dyne Steel, T. Forster Brown, J. Brogden, R. Laybourne, J. McMurtrie, E. Williams, J. Colquhoun, A. Hood, E. P. Martin, A. J. Stevens, H. W. Martin, H. K. Jordan, T. Evens, T. Hurry Riches, E. M. Hann, and T. H. Deakin.

C. Müller †† traces the history of the North-West Bohemian brown-coal mining.

Economics of Mining.—M. Mowley ††† discusses the economics of mining, and criticises adversely a number of expedients at present employed with what he claims is false economy, particularly in connection with coal-cutting.

A. Burnett §§ discusses the applications to which gas-engines could,

* *Engineering and Mining Journal*, vol. lxxxiv. pp. 1216-1219.

† *Ibid.*, vol. lxxxv. pp. 106-106.

‡ *Ibid.*, vol. lxxxiv. p. 833.

§ *Ibid.*, p. 1168.

|| *Braunkohle*, vol. vi. p. 406.

¶ *Transactions of the Institution of Mining Engineers*, vol. xxxiv. pp. 355-359.

** *Proceedings of the South Wales Institute of Engineers*, vol. xxv. pp. 387-403.

†† *Kohleninteressent*, 1907, p. 103.

††† Paper read before the National Association of Colliery Managers, December 7, 1907; *Iron and Coal Trades Review*, vol. lxxvi. pp. 145-148.

§§ *Engineering and Mining Journal*, vol. lxxxiv. pp. 914-917.

by being slightly modified, be put for the purpose of providing power for mining operations. The various requirements are shown to be such as could adequately be met by gas-engines, while the removal of the burnt gases, the modes of applying the gas drive, and the comparative cost of power production by steam, electricity, and gas are discussed in detail.

IX.—COAL SCREENING AND WASHING.

Coal Screening.—The Marcus coal screen and conveyor is described by H. Clark.* The principle is that of a trough with perforated bottom or otherwise, which is made to run backwards and forwards over the top of wheels. Unlike the Zimmer screen, which runs at 300 revolutions per minute, it works at 60 to 80 revolutions per minute. The propulsion gear is so constructed that by means of cranks and a connecting link a variable speed is produced. Beginning slowly at the commencement of the stroke, the trough increases in velocity up to three-quarters of the stroke, then slows down during the last quarter, reverses, and the return stroke is inversely the same as the forward. The slow speed at each end of the stroke tends to cushion the shock. The material is carried with the trough in its forward stroke, and as it increases in speed, it gradually imparts sufficient impetus to the material to overcome the frictional contact between the material and the trough in its backward stroke.

T. T. Christie † describes a waggon-lowering device for use at colliery screens.

John H. Haertter ‡ describes a temporary expedient employed at a time of drought in the southern anthracite coalfield, for an emergency water supply for a coal-breaker.

Coal Washing.—T. C. Futers § continues the series of articles on the mechanical engineering of collieries, in which are described various types of plant for coal washing.

The leading types of machines for washing bituminous coal are described by G. R. Delamater.||

E. Prost ¶ discusses the possibility of lessening the proportion of ash in coal by an electro-magnetic method.

A bibliography of coal-washing is given by S. S. Wyer.**

* Paper read before the National Association of Colliery Managers; *Iron and Coal Trades Review*, vol. lxxvi. pp. 337-338.

† *Transactions of the Institution of Mining Engineers*, vol. xxxiv. pp. 255-260.

‡ *Engineering and Mining Journal*, vol. lxxxiv. pp. 1124-1125.

§ *Colliery Guardian*, vol. xciv. pp. 952-953, 1003, 1048-1049, 1098, 1145.

|| *Mines and Minerals*, vol. xxviii. pp. 62-65.

¶ *Revue Universelle des Mines*, vol. xix. pp. 270-284.

** *Transactions of the American Institute of Mining Engineers*, vol. xxxvii. pp. 256-264.

Coal-handling.—A description has appeared* of the storage wharf and coal-handling apparatus of the Berwind Fuel Company, Superior, Wisconsin. The wharf has an approximate storing capacity of 350,000 tons of coal, and will have an ultimate capacity of about 700,000 tons.

A description has appeared† of two 30-ton coal hoists recently installed at the Town Dock of the Alexandra (Newport and South Wales) Docks and Railway Company.

J. I. Thomas ‡ describes the methods and apparatus employed by the Vinton Colliery Company at Vintondale, Pennsylvania, for transporting coal from the working face to main haulage roads by means of mechanical conveyors. The longwall method of mining is employed, and owing to the fact that this system of mining is not carried on to a large extent in the United States, the question of conveyors has received but little attention.

At the meeting of the Coal-Mining Institute of America at Pittsburg, on December 10 and 11, 1907, W. P. Young read a paper on the "Preparation of Coal for the Market," and M. R. Campbell read a paper on "A Practical Classification of Low Grade Coals."

The coal-handling plants in use at the leading collieries in Pennsylvania are described and illustrated by F. W. Parsons.§ Many of the installations present novel features, the methods of emptying the waggons being in a number of instances the outcome of long investigations as to performing this operation with the minimum of breakage and the maximum speed and convenience.

Illustrations have been published|| of an aerial ropeway erected at the Middleton colliery, near Leeds. The ropeway is 520 feet long, and carries 50 tons of washed slack per hour in 10 cwt. net loads.

An article¶ on the cost of conveying coal in motor waggons has been published in which comparative costs as compared with other methods of transport are given.

Briquette Manufacture.—A. S. Phillips** states that the improvement in the method of making briquettes in Wales consists in forming a pitchy deposit on each particle of coal or other carbon in as thin a film as possible, thereby producing a nearly smokeless fuel. This is accomplished by mixing a liquid tar with the coal in such quantities as to produce sufficient pitch when subjected to pressure and heat in a closed vessel.

F. Bock †† gives an account of coal briquette making, in which he gives illustrations of the leading presses employed. With an annual production of nearly 4,000,000 tons of briquettes, Germany is the chief briquette-producing country in the world.

* *Mines and Minerals*, vol. xxviii. pp. 313-314.

† *Colliery Guardian*, vol. xciv. p. 1050.

‡ Paper read before the Coal-Mining Institute of America, June 11-12, 1907; *Mines and Minerals*, vol. xxviii. pp. 200-203.

§ *Engineering and Mining Journal*, vol. lxxiv. pp. 740-744.

|| *Engineer*, vol. cv. p. 166.

¶ *Stahl und Eisen*, vol. xxvii. pp. 1596-1597.

** *Mines and Minerals*, vol. xxviii. p. 368.

†† *Glückauf*, vol. xlii. pp. 7-14.

E. Treptow * describes the briquetting of coal as carried out in the kingdom of Saxony. The Yeadon press, of which illustrations are given, is employed.

The briquetting of fuels in British Columbia is described by G. J. Mashek. †

The manufacture of brown-coal briquettes is described by A. Zeese. ‡

M. Rosenkranz § describes the utilisation of coke-dust produced in the Riga gasworks by compressing it into briquettes, the binding material being a mixture of thick tar and hard pitch.

The peat briquetting plant of the Commercial Artificial Fuel Company, near Lambertville, Michigan, has a capacity of 60 tons daily, the product containing 16·7 per cent. moisture, 55·3 volatile matter, 20·5 fixed carbon, and 7·5 ash. Its heating value is stated to be about 10,600 British thermal units per lb. The peat is obtained from a 10-foot bog by a dipper dredge, and taken in scrows to the plant. Here it is first passed through a cutter, in which it is thoroughly disintegrated, and then through a kneading machine. It is next compressed and discharged through a die as 4 inch by 4 inch bars, which are cut by knives into briquettes 12 inches long. The latter are then dried like soft brick in sheds. ||

A field of investigation which promises to have a distinct bearing upon the better utilisation of American coals is that of briquetting, and the present condition of the coal briquetting industry in the United States is summarised in a paper by E. W. Parker. ¶

F. Bulask ** describes the preparation of peat fuel in Michigan. When taken from the bog the peat is brown and fibrous, but after drying and compression it has a dense coal-like appearance, and burns with a log flame.

Jahrbuch für das Berg- und Hüttenwesen im Königreiche Sachsen, 1907, pp. 35-48.

† *Canadian Mining Journal*, vol. xxix. pp. 661-664, 685-687.

‡ *Braunkohle*, vol. vi. pp. 37-40, 501.

§ *Journal für Gasbeleuchtung*, vol. 1. pp. 197-199.

|| *Engineer*, vol. civ. p. 597.

¶ *United States Geological Survey, Bulletin* No. 316, pp. 460-485.

** *Power*, vol. xxvii. p. 591.

PRODUCTION OF PIG IRON.

CONTENTS.

	PAGE		PAGE
I. Blast-Furnace Practice . . .	308	III. Blast-Furnace Slags . . .	323
II. Chemical Composition of Pig Iron	322	IV. Foundry Practice . . .	324

I.—BLAST-FURNACE PRACTICE.

Theory of the Blast-furnace.—C. Briker * contributes a theoretical paper on blast-furnace diagrams and the facts to be deduced from them. The paper is accompanied by a number of curves giving a graphic representation of the co-ordination of the data discussed.

Improvements in Blast-furnace Practice.—F. W. Lürmann † gives an account of the changes which have taken place in blast-furnace practice since the introduction of the Lürmann cinder notch. Originally, the difference between the centre level of tuyeres and slag outlet was only 6 inches. The experience gathered by the introduction of the Lürmann slag outlet, and the advantage of its employment, led to an increase of this margin between the centre of the tuyeres and slag outlet. This margin has now been increased up to 5 feet to 6 feet at some blast-furnaces; that is, the tuyeres lie 9 feet, and the slag outlet is 40 inches, above the bottom. The hearth can, with a diameter of 160 inches at the height mentioned with 450 cubic feet contents up to the slag outlet, take up 80 tons of molten iron before it would reach the slag outlet and thereby endanger it. The contents of the hearth up to the tuyeres are then 1100 cubic feet; therefore, there can be 40 tons of slag collected above the 80 tons of molten iron before it reaches up to the tuyeres. The tuyeres can, therefore, even when the charges are rapidly put into the furnace, be kept free of slag, so that the blast can enter into the hearth without meeting any obstruction. The bottom of the hearth becomes hotter the nearer the tuyeres are; that is, when the difference in the height is small and the furnace is in good working order, the

* *Stahl und Eisen*, vol. xxviii. pp. 391-397.

† *Iron and Coal Trades Review*, vol. lxxv. p. 734.

bottom is melted and the hearth becomes deeper. The increase in the working time, and of the volume of blast rendered possible by the employment of the Lürmann slag outlet, and the increase in the diameter of the hearth, and in the height of the furnace, also render it possible to increase the number of charges, and therefore also the production of pig iron.

J. J. Porter* discusses recent progress and present problems in blast-furnace practice. The subjects dealt with are increased production, the size of furnaces, rate of driving the blast, the yield, the fuel ratio, problems connected with blowing, including the ratio of blast to fuel, and the causes of failure in large furnaces. Fuel economy is also considered and the calculation of thermal efficiency, and the cause of low efficiency. The effect of the introduction of Mesabi ores, and the difficulties experienced owing to hanging furnaces and serious slips, are also discussed. The most promising lines for future work are enumerated as: (1) smaller volume of slag, (2) dry air for blast, (3) lower silicon, and (4) lower carbon in the iron, (5) increase in temperature of blast, (6) decrease in weight of gases, (7) in critical temperature, and (8) in carbon solution, and, finally, (9) increased regularity in working. Each of these questions is discussed separately.

C. H. Ridsdale † discusses the application of science in iron and steel manufacture, with special reference to blast-furnace practice, and shows the evil effects and loss caused by extra silica due to shale, &c., in the ironstone, and that the effects of all bad materials are cumulative, and the shale and dirt brought to bank are not only a loss, but, if traced further, are seen to be a "snowball" of waste, and a dead loss to the district and country, placing them in a worse position for outside competition. Deterioration of quality of ironstone through less careful working on a works using 200,000 tons per year is serious. If it only falls from 28 to 26 per cent. iron, this means in round figures that instead of 100 parts normal stone only 93 parts are received, and 7 parts extra shale, &c., diluting it and requiring limestone to flux it. This is a direct loss (through iron not received) of 4300 tons of pig, besides extra loss through irregular working of blast-furnaces. To get the same output, besides much extra limestone needed and slag produced, more coke must be burnt and blast blown, and more weight in the proportion of 100 to 93 has to be shunted, lifted, calcined, wheeled, &c.

The need is strongly urged for the adoption of standard qualities not only for coal, ironstone, ores, &c., but for minor materials, such as lubricants, boiler composition, alloys, &c. The greatest disadvantage of the industry is irregularity. If everything were bought and sold to well-defined standards much of the irregularity would be removed, and one could rely in buying on always getting for a given grade exactly the same quality of article. Then many of the fluctua-

* *Iron Trade Review*, vol. xlii. pp. 33-40.

† Presidential address before the Cleveland Institution of Engineers, November 1, 1907, *Proceedings*, 1907-8, pp. 12-39; *Iron and Coal Trades Review*, vol. lxxv. pp. 1854-1855.

tions in price from competition of varying qualities would vanish and markets be steadier. Standardisation of raw materials will have to come if progress is to be made with the further products. Then the relative responsibility of the different sections of the industries would be clearly decided.

Scaffolding at Blast-furnaces.—R. Catani * describes the causes and results of the explosion which occurred on August 3, 1907, at blast-furnace No. 2 of the "Società Elba" at Portoferraio.

The blast-furnaces of the Società Elba at Portoferraio are installed under the best conditions. They are erected on solid ground, the highest point of the installation being 27 feet above the sea-level, in order to avoid the infiltration of external waters and easily to carry away the water used for cooling.

The treatment of the ore, the quality and quantity of pig iron produced, the dimensions and arrangement of the different parts composing the blast-furnaces, are all in accordance with the best practice of modern installations.

The blast-furnace No. 2 was started to work on October 20, 1903. Several improvements, especially in the lower part, were adopted in its construction. The walls of the crucible rest on a cylinder of fire-brick masonry of a diameter of 18 feet and of a height of 6 feet 6 inches; the brickwork cylinder is surrounded by a steel armour plate 1·6 inch thick, strengthened by steel rings. The walls and the bottom of the crucible are built with first-quality large fireproof bricks of British manufacture. Between the cylinder body and the well there is a hollow ring 1 foot wide, filled with fireproof clay. The whole structure rests on a cement and brick foundation carried down to good solid ground.

The blast-furnace thus built worked regularly up to the morning of August 3. Nothing wrong was noticed up to the occurrence of the accident. Sometimes an approaching breakout is indicated by steam escaping from the crucible or ground, but nothing of the kind had appeared in this instance. The automatic indicators remained quiet. The pressure of the blast, the temperature of the gas escaping from the furnace, and the action of the blowing-engines, registered by diagrams, proved the regularity of the work. The blast had been maintained for a long time at the constant pressure of 34 centimetres of mercury, the temperature of the escaping gases at between 150 and 175°, and the blowing-engines at a regular number of revolutions.

The last cast had been made between half-past six and seven o'clock on the morning; the iron was of very good chemical composition, fluid and in good quantity; it had a high content of silicon and the furnace worked with basic slag. This rises in the bottom of the crucible, even sometimes above the level of the tap-hole, and generally speaking does not give any fear of a probable breakout.

* *Rassegna Mineraria*, vol. xxvi. pp. 241-244.

At 9.40 the accident happened; five heavy detonations followed each other at intervals of a few seconds, and a thick black cloud surrounded the furnace. To the left-hand side of the tap-hole the ground and the paving were torn up over an area of about 3 or 4 square yards. The explosion certainly took place outside the furnace. The molten pig iron passing through the internal fireproof masonry, perhaps between the masonry of the crucible and that of the foundations, had pierced the steel armour plate, and got between the crucible and the masonry of the iron columns. This space was closed on the top by a layer of bricks. The molten pig iron, in fact, must have produced a rapid evaporation of the underground water, and the resulting steam increasing in pressure produced the explosion.

A great deal was said about the "explosion of the furnace," but what really happened was a breakout, which would not have had the disastrous consequences it did if the molten iron had not got into contact with water in a closed place, setting up the condition of a steam boiler. The hypothesis that the explosion occurred inside the furnace is inadmissible; an examination of the diagrams in the controlling apparatus showed that no increase took place in the pressure of the blast, and the temperature of the escaping gases was raised only from 175 to 240°.

B. Osann * has given a good description of the various blast-furnace bears. The composition of bears obtained from blast-furnaces working under different conditions is given. The author then gives his views as to the causes which bring about growing of the bottom of furnaces and other abnormal conditions of work, which are met with from time to time.

A contribution to the study of accidents in blast-furnace working has been published.†

The Destructive Action of Graphite on Blast-furnace Linings.—B. Osann † has contributed experimental evidence to prove that graphite has a destructive action on blast-furnace linings. It has long been known that the decomposition of carbonic oxide gas into graphitic carbon and carbonic acid gas takes place in the upper zones of the blast-furnace at a temperature of about 500° C., and is brought about in the presence of ferric oxide. The author has set himself to prove experimentally the deleterious influence of iron oxides in the bricks. The experiments were carried out in a glass combustion tube heated to a temperature of about 500° C., the materials to be tested being placed in the tube in a porcelain boat. Carbonic oxide gas was then slowly passed over the material for periods varying from seven hours to seventeen days. Reproductions are given of the materials after treatment, showing the penetrating action of the graphite on the firebricks and oxides.

* *Stahl und Eisen*, vol. xxvii. pp. 1491-1496 and 1529-1536.

† *Rassegna Mineraria*, vol. xxvii. pp. 241-244.

‡ *Stahl und Eisen*, vol. xxvii. pp. 1626-1628.

Phosphatic Chalk for Blast-furnace Use.—An interesting description of the deposits of phosphatic chalk which occur in Belgium and in the north of France in the departments of the Aisne, Somme, Pas-de-Calais, and Nord, has appeared.* This material is used to a considerable extent in blast-furnace practice, as a source of phosphorus and lime. Details of the extent to which these materials are now used in German blast-furnace practice are given, together with the cost of tariff rates, &c. The following typical analysis of these materials in the dry state are given:—

Belgian.

P.	SiO ₂ .	CaO.	MgO.	Al ₂ O ₃ .	Fe.	H ₂ O.	CO ₂ .
Per Cent.	Per Cent.	Per Cent.	Per Cent.	Per Cent.	Per Cent.	Per Cent.	Per Cent.
3·76	2·15	51·13	0·75	1·44	0·92	12·20	...
4·31	2·20	38·40	0·69	12·20	0·75	12·24	30·22
4·11	2·13	48·32	0·46	6·29	0·73	12·68	30·95
3·74	2·41	51·27	0·83	0·55	0·64	14·42	32·47

French.

P.	SiO ₂ .	CaO.	MgO.	Al ₂ O ₃ .	Fe.	H ₂ O.	CO ₂ .	S.
Per Cent.	Per Cent.	Per Cent.	Per Cent.	Per Cent.	Per Cent.	Per Cent.	Per Cent.	Per Cent.
6·32	0·30	53·41	trace	1·01	1·77	13·85	26·02	...
5·60	0·52	53·46	0·31	0·38	0·47	13·22	23·94	0·26
6·46	0·48	48·34	0·84	1·14	0·82	13·85	25·48	0·23
6·78	0·72	53·86	0·69	0·44	0·66	14·71	26·25	0·25
7·12	8·34	51·02	0·42	2·58	0·57	13·21	24·27	0·28

Zinc in the Blast-furnace.—J. J. Porter † deals with certain problems arising from the presence of zinc in the ores used in blast-furnaces in Virginia. The ores are derived from the Oriskany formation, and contain traces up to 1 per cent. of zinc oxide. The course of zinc in the blast-furnace is readily traced, and the reactions to which it gives rise are described. A small proportion escapes reduction and enters the slag as zinc oxide; the bulk is, however, ultimately deposited in hard lumps on the furnace linings as cadmia. The presence of zinc gives rise to three classes of disturbances: (1) Mechanical, (2) physical, and (3) chemical. Under the first head are troubles such as choking of the stove checkers and gas flues by zinc oxide dust, and obstruction of the down-comers and furnace throat by cadmia deposits. The physical disturbances include absorption of heat by

* *Stahl und Eisen*, vol. xxvii. pp. 1668-1669.

† *Bi-Monthly Bulletin of the American Institute of Mining Engineers*, 1907, pp. 739-745.

masses of cadmia which reach the hearth, while the chemical action results in the deterioration the linings undergo, due to the presence of zinc oxide. The remedy for this would be to ascertain what brands of brick best resist the action of zinc vapours. Generally speaking, the presence of zinc in the district where it occurs may lead to scaffolding and serious slips.

Clearing Tapholes.—R. Grimshaw* describes the process invented by Meune for clearing the tapholes of blast-furnaces by means of hydrogen and compressed oxygen. The stream of gas not only melts the iron, but also blows it away from the hole. When hydrogen is not available, generator gas or ordinary illuminating gas may be used to start the operation.

Charging Arrangements.—An illustrated description has appeared † of an automatic electric skip hoist for serving a new blast-furnace recently put into operation at McKeesport, Pennsylvania.

Works Machinery.—M. Buhle ‡ describes a new electrical overhead runway for waggons, adapted for use at blast-furnace plants and other purposes.

Purifying Boiler Feed-water.—The use of injurious and spurious boiler compositions, and the injury thereby occasioned to the boilers themselves, is discussed.§

Blowing-engines.—One of the largest, if not the largest, gas blowing-engine in Great Britain is described and illustrated.|| It has recently been completed by the Premier Gas-engine Company, Limited, for the works of Sir Alfred Hickman, Limited. The blowing-tubs are designed to deliver 40,000 cubic feet of air per minute.

P. Langer ¶ deals very fully with turbo-blowers for the supply of blast to blast-furnaces, with the aid of several illustrations. All the modern forms of turbo-blowers are described, including the Rateau, the Brown-Boveri-Rateau, the Parsons, the Jaeger, &c. Diagrams and curves of the results obtained, and comparison with steam-engines, are given; also a list of firms who have installed turbo-blowers, with tabular details of the plant erected.

K. Rummel** describes a steam turbine blowing-engine of the Brown-Boveri-Rateau type. It has a horse-power of 750.

A. Gradenwitz †† shows the economies which may be effected by the installation of low-pressure turbines, particularly in steelworks and mining plants.

* *Engineering and Mining Journal*, vol. lxxxiv. p. 1206.

† *Industrial World*, vol. xli. pp. 1590-1591.

‡ *Stahl und Eisen*, vol. xxviii. pp. 299-302.

§ *Lassen and Hjort Gasette*, January 1908.

|| *Engineer*, vol. cv. p. 140.

¶ *Stahl und Eisen*, vol. xxviii. pp. 73-82.

** *Zeitschrift des Vereines deutscher Ingenieure*, vol. li. pp. 1845-1852.

†† *Engineering Magazine*, vol. xxxiv. pp. 278-293.

P. J. Mitchell* describes the Rateau apparatus which has been installed at Auckland Park colliery, near Bishop Auckland, where it had become necessary to increase the amount of electrical energy available at the colliery. The system has been adopted for a very large installation at the Cleveland Steelworks and blast-furnaces. The plant consists of a large accumulator and two Rateau turbo-blowers, each of 25,000 cubic feet per minute, running at 2800 revolutions per minute, and blowing to a maximum of 10 lbs. per square inch; also one 1000-kilowatts turbo-alternator, 1800 revolutions per minute, 60 periods, 500 volts.

A summarised translation of a paper on exhaust steam turbines, read before the Society of Belgian Engineers, has been published.†

H. Wedding‡ gives an account of an explosion in the air chamber of a blowing-engine at the Hasper Iron and Steel Works.

A new type of high-pressure rotary-blower for metallurgical use is described by B. Sjövall§

Blast-furnace Gases.—I. V. Robinson|| gives some comparative figures of the cost of power generated by gas and by water. The results show that the power generated from blast-furnace gas costs about the same as water-power when the capital cost of the generating station, with or without transmission lines as may be required, is about £18 per horse-power, delivered at the consumer's boundary. The cost price of blast-furnace gas-engine power is estimated at £1, 14s. 4d. per horse-power per year for a plant with a life of twenty years to £2, 1s. 10d. for a plant with a life of ten years.

F. Limbourg¶ gives an example of the utilisation of the gases from a modern continental blast-furnace plant consisting of five blast-furnaces producing 180 tons of pig iron per day each. Blast is turned off, for cleaning and repairs, thirty-six hours per month. The make of pig iron is therefore $5 \times 180 \times 28.5$, or 25,650 tons per month. Each ton of pig iron made is accompanied by the production of 4500 cubic metres of gas, of a calorific value of 900 calories per cubic metre. Of this gas 7 per cent. is lost, and 38 per cent. used for heating the blast. This leaves $4,500 \times 25,650 \times \frac{6.5}{100} \times \frac{1}{30} = 2,116,125$ cubic metres of gas available for power purposes per diem.

The application of the available gases in various parts of the installation is as follows:—

Gas-engines.—There are six blowing-engines, one of which is held in reserve. Their effective horse-power is 5.5 per ton of pig iron, the maximum horse-power being 6.25 per ton. They run on an average at 5.5 : 6.25, or 88 per cent., and consume 2700 calories, or 3 cubic metres of gas per horse-power hour, or, in twenty-four hours, 356,400

* *Proceedings of the Cleveland Institution of Engineers*, 1908, pp. 97-176.

† *Engineer*, vol. cv. pp. 267-268.

‡ *Verhandlungen des Vereins zur Beförderung des Gewerbfleisses*, 1907, pp. 496-502.

§ *Blad för Bergshandterings Vänner*, vol. xii. pp. 77-88.

|| *Transactions of the Institution of Engineers and Shipbuilders in Scotland*, January 21, 1908.

¶ *Revue de Metallurgie*, vol. iv. pp. 945-952.

cubic metres of gas. For the blowing of the Bessemer converters, of which there are four, making three heats of 12.5 tons of pig iron per hour, with a yield of 82 per cent., there are two engines provided, one of which is held in reserve. The consumption of gas for blowing works out at 151,592 cubic metres per twenty-four hours. The hydraulic plant involves the use of 29,400 cubic metres per twenty-four hours for the compressors, and the open-hearth plant, which converts three-fifths of the pig iron not employed in the Bessemer works, and consists of three 25-ton furnaces tapping three times each per twenty-four hours, does not call for the consumption of gas.

Steam-engines.—Details of the steam-driven mill-engines are given. They involve the consumption of 540,970 cubic metres of gas under the boilers.

Turbine-engines.—The mills not driven by steam-engines derive their power from a steam-turbine plant generating electricity. Three trains of mills require an aggregate of 1955 effective horse-power. The accessory machinery for the mills and workshops also derive their power from this turbine plant. The total amounts to 4806 horse-power, which, for the purposes of calculation, is regarded as equivalent to 5000 effective horse-power, in round numbers. This requires for its generation 769,860 cubic metres per twenty-four hours. Other directions in which the waste gases can be utilised are given, and a comparison instituted between a plant such as described, and one in which gas-engines would be used throughout. A detailed examination of the various amounts of gas employed in different parts of the works results in the conclusion that, with the exception of an insignificant consumption of 25 tons of coal per day for certain requirements, the whole power for such a works could be derived from the coke actually consumed in the blast-furnace for the production of pig iron.

F. E. Junge* gives the results obtained in the application of blast-furnace and coke-oven gases. On an annual output of 24 million tons the use of the waste gases from these two sources may be roughly estimated as equivalent to over half-a-crown per ton. The most important set of conditions is when the available gases can not only supply the power requirements of the whole of the works, but also furnish a surplus for use outside, or for other purposes. Of the total gases produced in a blast-furnace, about 45 per cent. is employed in heating the blast stoves and 15 per cent. for motive purposes, leaving 40 per cent. available for other requirements. Taking German practice, a research made by A. Nagel shows the composition of an average blast-furnace to be :—

	Per Cent.
Carbon	29
Hydrogen	3
Carbon dioxide	8
Nitrogen	60
	100

* *Iron Trade Review*, vol. xlii. pp. 25-32.

At normal atmospheric pressure and temperature such a gas has a value of 100 British thermal units per cubic foot, while about 4300 cubic metres of gas are produced per ton of pig iron made. After providing for the blast-stove requirements there is still a surplus of about 3000 cubic metres available, and, after allowing for the power requirements of the blowing-engines, as much as 2800 cubic metres may still remain for other purposes. Looking at the matter from another standpoint it may be said that a blast-furnace producing 100 tons of pig iron daily will yield a continuous surplus of 3000 horse-power per hour, after providing for all the requirements contingent on the actual smelting of the pig iron produced. The conditions obtaining in Belgian practice are then considered with special reference to the experiences obtained at Seraing as to the relative advantages of gas and steam-power, and a detailed statement is given of the cost of installing and operating a 3600 horse-power gas-engine using blast-furnace gases. The relative merits of various systems of gas-cleaning are also discussed, and the leading types of plant for this purpose described and illustrated.

The value of the coke-oven is next considered from the point of view of the production of available gases, and L. Greiner's estimate that a modern by-product coke oven produces 240 cubic metres of gas of about 4000 calories thermal value per metre ton of coal of average composition, is taken as a basis. The gas is relatively high in hydrogen, and about 65 per cent. is required for the internal purposes of coking; this leaves 35 per cent. available for power generation outside the coking operations proper, or 135 horse-power per ton of coal. This, with a modern coke oven of the by-product type, and having a capacity of 7 tons, amounts to a continuous surplus supply equivalent to 5.6 horse-power per oven. Taking the efficiency of conversion to be 75 to 80 per cent., the production of power is about 7 horse-power per ton of coke per day, or, roughly speaking, the available power per hour is equal to the number of tons of coke produced per week. Taking German practice and the Ruhr district, with an annual production of 600,000 tons of coal, of which one-fourth is coked, the waste heat and waste gases would generate a continuous capacity of 3000 horse-power, while at the largest German colliery, "Rheinpreussen," where the annual output will shortly reach 3,000,000 tons of coal, of which one-third is coked, a conservative estimate shows 17,000 horse-power to be continuously generated in gas-engines from the available coke-oven gases. The subject of the transmission and distribution of power from coke ovens is dealt with, and dimensioned drawings of a complete gas-power plant installed at the Hasper Iron and Steel Works given. Finally, the economic considerations, the cost of electrical energy generated by means of surplus gases, and the advantages of pooling and central station installations are considered in the light of the influence such means are likely to have on the industrial progress of the district, and the question is raised as to whether the correlation of the power so available should be left to private enterprise, or undertaken by the State.

H. Allen * concludes his discussion of problems involved in blast-furnace practice by dealing with the question of utilising the waste gases. The maximum thermal efficiency of these gases can only be obtained by preliminary purification, and to achieve this effectually cooling must be resorted to, notwithstanding that the sensible heat of the gases is 9 per cent. of the heating value of the fuel burnt. Gas-cleaning plant is then dealt with, illustrated descriptions being given of the Thwaite-Gardner plant, the plant at Differdinge, and a Belgian plant for dealing with 4600 horse-power blast-furnace gases.

W. Schmidhammer † contributes some interesting figures on the possibility of regenerating blast-furnace gas so as to utilise it for steel-melting purposes and otherwise.

L. Greiner ‡ deals with the utilisation of blast-furnace gases in metallurgy; illustrations of the plant at the Cockerill Works, Seraing, being given.

B. H. Thwaite § discusses the blast-furnace as a centre of power production.

F. Limbourg || discusses the use of blast-furnace gas as a source of power in a modern ironworks.

Illustrations have been published ¶ of a 900 brake horse-power blast-furnace gas-engine which has been in operation at the Brymbo Steelworks since March 1908.

H. L. Callendar ** and W. E. Dalby describe the determination of temperatures in the cylinders of gas-engines.

An exhaustive paper on the construction and working of large gas-engines was read before the Manchester Association of Engineers by P. R. Allen. †† He gave some particulars of large engines which are about to be installed. These include engines of 48,000 horse-power in units of 2000 horse-power, built by Thyssen & Company, for steelworks in Germany; 36 duplicate units of 4500 horse-power by the Allis, Chalmers Company, with cylinders 44 inches diameter by 54 inches stroke, arranged twin tandem fashion and running at 83 revolutions per minute, and a single-cylinder Körting engine by Siegener & Company, with cylinders $43\frac{1}{2}$ inches by $55\frac{1}{2}$ inches, running at 85 revolutions per minute.

G. Mees †† and K. Kutzbach discuss the influence of the gaseous mixture on the thermal efficiency of gas-engines.

H. Baer §§ and H. Bonte give the results of the experience obtained in the construction and working of gas blowing-engines.

E. T. Adams ||| deals with the development of the large gas-engine in the United States, and gives a description of the plants installed, or on order, for steelworks in that country.

* *Iron Trade Review*, vol. xli. pp. 583-590.

† *Stahl und Eisen*, vol. xxviii. pp. 127-128.

‡ *Cassier's Magazine*, vol. xxxiii. pp. 68-82.

§ *Ibid.*, pp. 23-40.

|| *Revue de la Metallurgie*, vol. iv. pp. 945-952.

¶ *Engineer*, vol. cv. p. 459-460.

** *Proceedings of the Royal Society*, vol. lxxx., Series A, pp. 57-74.

†† January 11, 1908.

‡‡ *Zeitschrift des Vereines deutscher Ingenieure*, vol. li. pp. 1586, 1647.

§§ *Ibid.*, vol. lii. pp. 1-8.

||| *Cassier's Magazine*, vol. xxxiii. pp. 41-54.

Gas-cleaning.—In a paper on the cost of power production, I. V. Robinson * states that gas-cleaning plant for blast-furnace gas varies according to the fuel used in the furnace. In Scotland, where bituminous coal is the chief fuel, there is a lot of tar remaining in the gas after it has passed through the by-product plant. This tar has been successfully removed by a cleaner introduced by the Summerlee Iron Company. The gas is made to pass through a number of narrow orifices and to impinge upon an inclined surface when moving at a high velocity. The heavier tar adheres to the surface and runs down to an inclined tray from which it is removed at intervals. In the Summerlee cleaner, the gas is drawn through the orifices by the suction of the gas cylinder when the engine drives a blowing cylinder. The gas reaches the cylinder under a vacuum of from 6 inches to 12 inches water gauge according to the atmospheric conditions. For electric power gas-engines, it is advisable to force the gas through the cleaner by a centrifugal fan, to avoid any variation in the suction pressure and to ensure a more regular speed. Where coke is used as the fuel in the blast-furnace, there is no tar and the chief trouble is dust. The Theisen gas cleaner has proved successful in removing dust, and consists of a motor-driven cylindrical drum fitted with projecting vanes. Water and gas enter the annular space round the drum at opposite ends and the water removes the dust. The gas then passes into a vapour-separating chamber and is thoroughly dried. During a three months' test with a Theisen cleaner the quantity of dust contained by the emerging gas varied from 0·0019 to 0·0043 grammes per cubic metre, i.e. 0·0019 to 0·0043 ounces per 1000 cubic feet—about half a litre of water was used per cubic metre of gas, or about 6½ gallons per 1000 cubic feet. Other forms of gas-cleaning apparatus are mentioned.

The Zschocke gas-cleaner is described by M. Wolf.†

The Staveley Ironworks.—Detailed drawings have been published ‡ of the three new blast-furnaces at the Devonshire ironworks of the Staveley Coal and Iron Company, Limited, Chesterfield. The new plant, for which C. P. Markham is responsible, shows that great discrimination has been exercised in weighing the relative merits of different systems in order that the many mechanical features in the complete equipment should be efficient. The height of the new furnaces is 70 feet, the bosh is 18 feet 6 inches, and the hearth 11 feet in diameter. The output averages 850 tons per furnace per week.

Austrian Blast-furnaces.—G. B. Waterhouse§ gives an account of the works and blast-furnaces of the Witkowitz Company, Moravia. Illustrations have also been published elsewhere|| of the new blast-furnaces at Witkowitz.

* *Institution of Engineers and Shipbuilders in Scotland*, January 21, 1908.

† *Génie Civil*, vol. liii. pp. 33-37.

‡ *Engineering*, vol. lxxxv. pp. 391-395 et seq.

§ *Iron Age*, vol. lxxx. pp. 1591-1594.

|| *Engineer*, vol. cv. p. 185.

German Blast-furnaces.—Descriptions have been published * of the Concordia ironworks at Bendorf and of the Rasselstein ironworks. † J. B. Van Brussel ‡ gives an account of the Krupp works.

Hungarian Blast-furnaces.—Descriptions have been published of the Diösgyör ironworks § and of the Resicza and Anina works. ||

Italian Blast-furnaces.—The Savona ironworks are described. ¶

Canadian Blast-furnaces.—G. D. Drummond ** describes the Midland furnace of the Canada Iron Furnace Company in Ontario. It smelts Lake Superior ore with Connellsville coke, and is 65 feet high by 13 feet bosh. It has a capacity of 100 to 140 tons per day.

Indian Blast-furnaces.—W. M'Farlane †† describes the Barakur ironworks in India. There are three blast-furnaces, but the steelworks have been shut down.

American Blast-furnaces.—The charcoal blast-furnace plant with recovery of by-products at Marquette, Michigan, is described. †††

The new Madeline furnace of the Inland Steel Company, Chicago, is described §§ and illustrated. The furnace is situated at Indiana Harbour, Indiana, immediately adjacent to the steel plant of the company. The furnace has a height of 85 feet, while the diameter at the bosh is 20 feet 6 inches. It is fitted with a M'Kee distributor, and has a capacity of 400 tons of pig iron daily. One unique feature of this furnace is that it is supported by six cast-iron columns, making the distribution of its twelve 6-inch tuyeres uniform and much more satisfactory than when eight columns are used, as has been the usual practice. The furnace is equipped with four Kennedy central combustion stoves each 93 feet high and 22 feet in diameter. Two down-comers, each 5 feet 9 inches inside diameter, connect with a dust-catcher 20 feet in diameter. Directly connected to the dust-catcher is a Mullen gas washer, from the opposite of which two leads convey gas to the boilers and stoves.

An illustrated description has appeared |||| of the new blast-furnace plant of the Shenango Furnace Company at Sharpsville, Pennsylvania. The furnace is 80 feet high, the diameter at the bosh 20 feet, and the diameter of the hearth 12 feet 6 inches. The capacity is to be about 300 to 400 tons per day. Hand-charging will be employed, the

* *Zeitschrift des Vereines deutscher Ingenieure*, vol. li. p. 1563.

† *Ibid.*, pp. 1563-1564.

‡ *Iron Trade Review*, vol. xli. pp. 535-544.

§ *Engineer*, vol. civ. pp. 280-284.

|| *Ibid.*, pp. 499-501.

¶ *Rassegna Mineraria*, vol. xxvi. pp. 177-179.

** *Journal of the Canadian Mining Institute*, vol. x. pp. 442-465.

†† *Transactions of the Mining and Geological Institute of India*, vol. i. pp. 147-153.

††† *Engineering Record*, 1907, pp. 410-411.

§§ *Industrial World*, vol. xlii. pp. 72-74, 89.

|||| *Iron Trade Review*, vol. xliii. pp. 17-24.

furnace being required to run close to analysis, and great care being needed in consequence to secure even distribution in the stack. A skip hoist may, however, be ultimately employed. Detailed diagrams are given of the arrangements in the throat, the down-comers, the stoves, construction of the furnace, washers, &c.

A record of blast-furnace construction during the year 1907 is given by B. E. V. Luty.* Fifteen new furnaces with a total capacity of 2,110,000 tons of pig iron yearly were completed and blown in during that period.

History of Iron.—J. L. Myres † suggests that Herodotus may be right in recording the same name, "Sigyunae," as applied to the "throwing-spear wholly made of iron" which characterised the Iron Age culture of Cyprus in early Hellenic times, more particularly as Cyprus preserves also a peculiar type of iron sword which only finds parallel in the Italo-Hallstatt region.

In a paper on the history of the compass in Arabia, E. Wiedemann ‡ gives some particulars of the history of iron extracted from an ancient Arabic work on cosmography written by Al Dimaschqui, who died in 1327. An Arabic writer, Al Kâti, who lived at the beginning of the eleventh century, states that iron occurs in two modifications, one male and the other female. Steel is the male variety and soft iron the female.

Otto Vogel § has endeavoured to ascertain where and when the first tilting furnace was built. He finds that the first furnace of the kind was used for heating cannon balls, and was described by J. G. Krünitz in 1785, the notice cited having been derived from a Leipzig journal of 1769.

F. Cartwright || sketches the history of iron manufacture in Sussex.

George Turner ¶ traces the history of the Scottish iron industry from the fifteenth to the seventeenth century. The later periods from 1700 to 1760,** and from 1760 to 1885, †† are dealt with by the same author elsewhere.

A description has appeared †† of an abandoned ironworks at Arigna, Roscommon, Ireland. The works were in operation from 1818 to 1836, and employed about 200 men. Not far from Arigna, at Creevelea, in the county of Leitrim, is another abandoned ironworks, of which an illustration is given. These latter works were erected in 1852. The furnace had a capacity of 30 tons per twenty-four hours, and at the time of its erection one of the best in the United Kingdom.

* *Iron Trade Review*, vol. xlii. pp. 106-108.

† *Report of the Seventy-seventh Meeting of the British Association*, p. 664. London, 1908.

‡ *Berichte der deutschen physikalischen Gesellschaft*, 1907, pp. 364-733.

§ *Stahl und Eisen*, vol. xxviii. p. 380.

|| *Gentleman's Magazine; Iron and Coal Trades Review*, vol. lxxv. p. 736.

¶ *Scotia*, vol. i. No. 2.

** *Ironmonger*, vol. cxx. pp. 530-531.

†† *Ibid.*, vol. cxviii. pp. 616-617.

‡‡ *Ibid.*, vol. cxviii. pp. 620-621.

F. Forcher von Aimbach,* in a contribution to the history of the Styrian iron industry, traces the trade relations existing in ancient times between the forges and sythe works of the Mur valley and foreign countries.

A. Müllner † traces the history of the iron industry in Carinthia in the sixteenth century.

K. Knapmann ‡ deals exhaustively with the history of the iron and steel wire industry of Altena.

A. Geyer § gives an account of the ancient and important industry in connection with the production of iron in the Harz district. In the year 1500 there were in existence thirty-two ironworks producing about 800 tons of malleable iron per annum. In 1600 there were thirty-three works with six blast-furnaces, with an output of 1500 tons of wrought iron and 130 tons of cast metal. In 1700 the blast-furnaces numbered fourteen, and the total production amounted to 3000 tons of wrought iron and 800 tons of cast iron in 1800; with twenty-two blast-furnaces, the totals were 4300 tons of wrought iron, and 1600 tons of cast iron; whilst in 1906 there were thirty-two works with a yield of 40,000 tons of raw pig iron and 50,000 tons of cast iron, with an approximate value of £1,500,000. The iron trade in this district employs about 12,000 workpeople. The ironworks are specially distinguished for their delicate castings for artistic purposes.

An account is given of the celebration of the centenary of the Royal Iron Foundry at Berlin. ||

P. Martell ¶ traces the history of metallurgy in Russia. In another paper ** he gives some notes on the history of Swedish ironworks at the end of the eighteenth century.

The history of iron in New Jersey is traced by E. P. Buffet. ††

T. D. Morgan †† describes the Tredegar ironworks in Richmond, Virginia, founded in 1836.

Numerous biographies and portraits of leaders in the iron and steel industries have been published: in *Page's Weekly* (vol. xi.) of W. H. Hatfield (p. 789); J. Dixon Brunton (p. 932); Henry Archibald (p. 986); C. H. Ridsdale (p. 986); (vol. xii.) William Beardmore (pp. 16-17); A. T. Walmisley (p. 268), and F. W. Harbord (p. 1120); in the *Syren and Shipping* (vol. xlvi.), Professor J. J. Welch (p. 182); A. D. Wedgwood (pp. 313, 315); Sir Alfred Hickman, Bart. (Supplement, February 5, 1908, pp. 1, 2); in the *Machinery Market*: W. H. Butlin (November 1, 1907, p. 9); T. Hurry Riches (February 7, 1908, p. 9); H. A. Hoy (April 3, 1908, p. 9); and S.

* *Zeitschrift des Historischen Vereins für Steiermark*, vol. v. pp. 1-86.

† *Oesterreichische Zeitschrift für Berg- und Hüttenwesen*, vol. lvi. pp. 51-55, 66-68.

‡ *Abhandlungen aus dem staatswissenschaftlichen Seminar zu Münster*, 1907, Part II.; *Stahl und Eisen*, vol. xxvii. pp. 1862-1863.

§ *Stahl und Eisen*, vol. xxvii. pp. 1412-1417.

|| *Giesserei Zeitung*, vol. iv. pp. 632-633.

¶ *Rigasche Industrie Zeitung*, 1907, pp. 213-215.

** *Oesterreichische Zeitschrift für Berg- und Hüttenwesen*, vol. lvi. pp. 153-160.

†† *Engineering and Mining Journal*, 1908, vol. lxxxv. pp. 309-310.

‡‡ *Iron Age*, 1907, vol. lxxx. pp. 1057-1059.

Cowper-Coles (May 1, 1908, p. 9). Biographies are published in *Affärsvärlden* of J. O. Kjellberg (vol. vii. p. 1590) and of Axel Johnson (p. 1523).

B. S. Stephenson * contributes an illustrated biographical notice of James M. Swank.

II.—CHEMICAL COMPOSITION OF PIG IRON.

Pig Iron Analyses.—The following analyses † show the quality of the foundry No. 3 pig iron and the forge No. 4 iron produced at the new blast-furnaces of the Devonshire works of the Staveley Coal and Iron Company, Limited:—

	Foundry 3.	Forge 3.
	Per Cent.	Per Cent.
Iron	91·88	92·52
Combined carbon	0·30	0·56
Graphite	3·05	2·60
Manganese	0·68	0·63
Silicon	2·52	2·05
Sulphur	0·02	0·07
Phosphorus	1·55	1·57
Total	100·00	100·00

Analyses of German Pig Iron.—In the sixth edition of the popular treatise on metallurgy issued by the Society of German Ironmasters the following typical analyses of pig iron are given:—†

	Total Carbon.	Silicon.	Manganese.	Phosphorus.	Sulphur.	Copper.
	Per Cent.	Per Cent.	Per Cent.	Per Cent.	Per Cent.	Per Cent.
I.	3·89	0·62	0·64	0·67	0·013	0·004
II.	3·42	2·92	0·76	0·48	0·042	0·030
III.	3·62	2·62	0·60	1·60	0·013	0·003
IV.	3·58	1·17	0·41	1·71	0·014	0·015
V.	4·02	0·84	0·29	0·06	0·052	0·062
VI.	3·41	1·11	0·39	0·73	0·092	0·011
VII.	3·4	1·0-3·0	0·3-0·5	0·20	trace	trace
VIII.	3·76	2·52	3·90	0·07	0·03	...
IX.	4-5	0·3-0·5	6-30	0·06-0·10	0·1	0·2-0·3
X.	5·5-7	0·5-1·5	up to 85	0·18-0·38	trace	0·02-0·1
XI.	1·0-1·5	8·5-15·0	1-4	0·06	0·02	...

I. No. 1 foundry pig, Dill-Lahn; II. Upper Silesia; III. No. 3 foundry pig, Lorraine-Luxemburg; IV. No. 5 foundry pig, Lorraine-Luxemburg; V. Special Kupferhütte pig; VI. Grey charcoal pig; VII. Siegerland charcoal pig; VIII. Bessemer pig; IX. Siegerland spiegelisen; X. Ferro-manganese; XI. Ferro-silicon.

* *Iron Trade Review*, vol. xlii. pp. 75-78.

† *Engineering*, vol. lxxv. p. 393-395.

‡ *Gemeinfassliche Darstellung des Eisenhüttenwesens*, p. 49. Düsseldorf, 1907.

Württemberg Pig Iron.—Robert Fluhr* gives the following analyses of the cold-blast pig iron produced at Wasseraalengen :—

	1865.	1887.	1907.
	Per Cent.	Per Cent.	Per Cent.
Silicon	3·26	4·01	2·4-3·3
Total carbon	2·25	2·62	3·2-3·7
Phosphorus	0·46	0·83	0·62-0·78
Manganese	0·38	0·34	0·30-0·35
Sulphur	0·03	0·09	0·03-0·06

The slag produced contains 39·82 per cent. of silica, 42·44 per cent. of lime, 1·03 per cent. of magnesia, 13·30 per cent. of alumina and 2·95 per cent. of ferrous oxide. The works now produce 7000 tons of castings annually and give employment to 1300 workmen. They were founded in 1668.

Brazilian Pig Iron.—In a pamphlet describing the Esperança ironworks in Brazil, J. J. de Queiroz † gives the following analyses of the pig iron produced :—

	Per Cent.
Graphite	3·51
Combined carbon	0·21
Silicon	0·40
Sulphur	0·007
Phosphorus	0·13
Manganese	0·40
Iron	93·35
Titanium	0·064

III.—BLAST-FURNACE SLAGS.

Fusibility of Lime-Alumina-Silica Mixtures.—R. Rieke ‡ has investigated the temperatures at which carefully prepared mixtures of these bodies, formed into Seger cones, fuse. Four series of tests were made, in each of which the molecular relation of alumina to silica was kept constant, namely, 1 : 1, 1 : 2, 1 : 3, and 1 : 4, whilst the lime added was increased in each series from 0·1 to 12 molecules of lime to 1 molecule of pure aluminium silicate. Tables of the melting points of the various mixtures are given.

The temperatures of the formation of slag are discussed by M. A. Pavlov.§

Titaniferous Slags.—C. N. Cox|| and L. C. Lennox have investigated the composition and properties of various mono-, sesqui-,

* *Zeitschrift für praktische Geologie*, vol. xvi. pp. 1-23.

† Rio de Janeiro, 1907.

‡ *Stahl und Eisen*, vol. xxviii. pp. 16-17.

§ *Gorni Journal*, 1907, pp. 1-22.

|| *Electrochemical and Metallurgical Industry*, vol. iv. p. 490-495.

bi-, and tri-silicate slags containing titanitic acid. These slags, whether containing alumina, lime, or magnesia in varying ratios, were all lower in melting-point than those usually found in the blast-furnace, so that there is no reason why the mixtures from which they were made should not be employed in practice.

Bricks from Blast-furnace Slags.—J. Butler * deals with the utilisation of blast-furnace slags, with special reference to the manufacture therefrom of concrete bricks. The cost of removing slag from a blast-furnace to the tipping ground varies from 4d. to 6d. per ton, and a furnace producing 800 to 1000 tons per week of pig iron would thus entail an annual expense of about £1000 for removal of the slag alone, exclusive of the rent for the ground upon which the slag has to be tipped. By running the molten slag into water and thus granulating it, an excellent brick-making material is available. The results obtained at a small experimental plant at the Landore works in the manufacture of concrete bricks from such slag are described. The plant laid down in 1904 produced such excellent bricks that a much larger plant has since been laid down at these works, and the daily production is now from 25,000 to 45,000 bricks. The bricks are pressed in the machines employed upon their 9-inch and 3-inch faces, instead of on the 9-inch and 4 $\frac{3}{8}$ -inch faces usually adopted, the result being a more solid and less porous brick. A full description is given of the granulating plant, the lime-grinding house, and presses, and of the processes employed, together with tests of the finished bricks, and details as to cost of manufacture.

Portland and Blast-furnace Cement.—H. Wedding † has contributed an important article dealing with the present position of cements made from blast-furnace slags, and compares such products not unfavourably with Portland cement.

IV.—FOUNDRY PRACTICE.

Cupola Practice.—A. R. Bellamy, ‡ dealing with the subject of foundry management, states that the method of charging the cupola, which he had found most satisfactory, was 10 cwts. of iron followed by $\frac{3}{4}$ cwt. of coke. For bringing raw material to the cupola, the direct-acting air-hoist and overhead tramway, although 1·2 per cent. less efficient than the electrical hoist, had been found simple and reliable. With gas-fired core stoves the cost per cubic yard per week worked out at 2·32d. against a cost by means of coke furnaces of 4·71d. per

* Paper read before the Staffordshire Iron and Steel Institute, January 18, 1906; *Iron and Coal Trades Review*, vol. lxxvi. pp. 325-329.

† *Stahl und Eisen*, vol. xxviii. pp. 219-226.

‡ Paper read before the Manchester Association of Engineers, November 9, 1907; *Times Engineering Supplement*, November 13, 1907, p. 6.

cubic yard per week, while the cores were more uniformly dried and the heat better distributed through the stoves.

The application of science to foundry work is discussed by Robert Buchanan.* The influence of carbon, silicon, manganese, phosphorus, and sulphur on the properties of cast iron is treated in detail.

J. H. Zemek † discusses the calorific effect of solid, liquid, and gaseous fuel, with special reference to the determination of the dimensions of foundry cupolas.

W. J. Keep ‡ describes the foundry cupola and the iron charged.

G. Buzek § has investigated the various factors which determine the amount of coke required for melting pig iron in the cupola. The theoretical heat units required are calculated for given cases. The author draws attention to the necessity of observing more closely the temperature and composition of the escaping gases from the cupola. Some tables are given of actual results in practice, with the analyses of the gas, temperatures, and fuel consumption.

F. W. Lürmann || has contributed an article on the arrangement of a cupola plant in reference to the work it is to be called upon to perform with regard to economy of fuel and proper adjustment of blast. Some interesting data in reference to cupolas with and without fire-hearths is given in a tabular form.

The use of metal direct from the blast-furnace for foundry purposes, especially for pipe casting, is discussed in a lengthy paper by C. Irresberger. ¶

A handy type of small cupola constructed by George Green & Co. of Keighley for melting small quantities of metal in case of emergency is described. **

Otto S. Schmidt †† contributes an article on the use of compressed air in foundries. Compressed air was first utilised in foundries in America, and later in Germany, where it was equally successful. At the present time the majority of the large foundries are furnished with the latest appliances driven by compressed air. The author describes the following machines, all driven by compressed air, and gives calculations showing the economy due to such working: Sand-cleaning machines, moulding machines, lifting apparatus, riddling machines, removable drying stoves, also stamping and chisel machines.

The economics of foundry construction and practice are discussed by A. R. Bellamy. †††

Cupola Blowers.—W. B. Snow §§ deals with foundry blower practice, and discusses the relative performances of fan and rotary blowers.

* *Journal of the Royal Society of Arts*, vol. lvi. pp. 317-328.

† *Giesserei Zeitung*, vol. iv. pp. 687-691.

‡ *Proceedings of the American Society of Mechanical Engineers*, vol. xxix. p. 367.

§ *Stahl und Eisen*, vol. xxviii. pp. 145-149, 229-233.

|| *Ibid.*, pp. 302-305.

¶ *Ibid.*, pp. 122-127.

** *Engineering*, vol. lxxv. p. 413.

†† *Stahl und Eisen*, vol. xxviii. pp. 8-16.

††† *Iron and Coal Trades Review*, vol. lxxv. pp. 1852-1853.

§§ Paper read at the New York meeting of the American Society of Mechanical Engineers, December 1907; *Mechanical Engineer*, vol. xxi. pp. 50-53, 75-77; *Iron Trade Review*, vol. xii. pp. 955-961.

He gives formulæ for the problems involved, and compares the relative value of fan and rotary blowers. Notes on the design of fan blowers are given, and recent improvements in their design and construction recorded. Rotary blowers are similarly discussed, and the merits of each type summarised. The question of outlet is considered in relation to fuel economy and the composition of the waste gases. Diagrams of the performance of blowers of various types are given.

A new form of centrifugal air-compressor, specially adapted for gas and other furnaces, and for foundry cupola service, is described.* It is driven electrically, and resembles a positive pressure blower.

An illustrated description is given † of the new types of electric centrifugal air-compressors constructed by the General Electric Company, Schenectady, New York, for all purposes for which air under pressure is employed, including use in foundry cupolas. The compressors can also be used for air furnaces and gas furnaces.

Foundry Appliances.—J. H. Zemek ‡ describes several appliances adapted to furnaces to improve combustion and regulate the supply of air. He also describes a drying-chamber for moulds with hollow walls, in which the draught is regulated mechanically in order to avoid incomplete combustion and to obtain a good circulation of hot air, and a fan is provided to exhaust the saturated air.

The Quincy-Manchester-Sargent Steel Foundry cold saw for cutting off risers from any form of castings requiring a flat table is described § and illustrated.

Modern foundry casting-ladles and cranes are described by C. Michenfelder.||

Foundry Mixtures.—W. J. Keep ¶ discusses various questions relating to foundry practice and to iron mixtures.

H. M. Lane ** gives the results of a volumetric study of cast iron, and deals with the volume of the so-called impurities present in cast iron. A No. 2 foundry iron containing 6·93 per cent. by weight of impurities contains 35·73 per cent. by volume. This explains the complete change of properties caused by the addition of only 7 per cent. of impurities to Swedish iron.

Eckwaldt †† describes experiments made by Neumeier at the Alexandrowski ironworks, Ekaterinoslav, on the desulphurisation of a pig iron having the following composition, Si = 3·19, Mn = 0·23, S = 0·102,

* *Iron Trade Review*, vol. xli. pp. 796-798.

† *Iron Age*, vol. lxxx. pp. 1376-1378.

‡ *Giesserei Zeitung*, vol. iv. pp. 526-529.

§ *Iron Trade Review*, vol. xli. p. 629.

¶ *Dinglers Polytechnisches Journal*, vol. cccxxii. pp. 663-666, 679-683.

¶ Paper read before the American Society of Mechanical Engineers; *Iron Trade Review*, vol. xli. p. 971.

** *Proceedings of the American Society of Mechanical Engineers*, vol. xxix. pp. 467-475.

†† *Giesserei Zeitung*, vol. iv. pp. 513-516.

in the cupola, coke with 1·4 per cent. sulphur being employed. The meltings were made in several series, pig iron from the same cast being always used, and variations being made in the addition of manganese ore and spiegeleisen. The results of all the experiments are given, and they show without any doubt that the desulphurisation of an iron very rich in sulphur is possible by a second melting in the cupola.

Chemistry in the Foundry.—Max Orthey * advocates accurate chemical analyses for the examination of pig iron, instead of judging the quality by the intensity of certain defined reactions. Sampling requires great care. Taking sample filings requires considerable time and labour, and can scarcely be recommended. Planing the surface of the fracture is the best method, but many foundries do not possess a planing machine, and the preparation of samples in this manner is impossible. Drilling is recommended in such cases, but owing to the impurities of the iron not being equally distributed in the pigs, the skin should be removed. Several pigs in each load should be examined. The author gives a table which shows the extraordinary differences in the chemical composition of pigs of the same cast. The estimation of the silica in pig iron is misleading, because a pig iron rich in graphite, and apparently poor in silicon, often leaves more insoluble residue than a pig iron rich in silicon and poor in graphite. Instead of the testing of sulphur by the black coloration of a plate of silver, the introduction of the developed gases into a solution of cadmium acetate is recommended. The determination of the percentage of manganese by comparing the colour of a fusion with soda is quite erroneous. More correct results are obtained by the peroxide of lead and nitric acid test. If chemical analysis is to be of real value in foundry practice, it must be carried out in a more exact and scientific manner.

Electric Furnaces for Foundry Work.—J. B. C. Kershaw † considers the application of electric furnaces for the melting of iron and brass in the foundry. The types suitable for this class of work are the Faure, Girod, Héroult, Keller, and Kjellin furnaces, each of which is described and illustrated. As a general rule 400 to 500 kilowatt-hours would suffice to melt 1 ton of iron, and the cost would not exceed three shillings and sixpence per ton. The electric method may compare favourably with the older cupola methods, but preliminary experiments in this direction should be made before attempting to supersede the latter.

Machine-Cast and Sand-Cast Pig Iron for Foundry Work.—C. W. Mason ‡ compares the relative merits of pig iron cast in sand

* *Giesserei Zeitung*, vol. iv. pp. 613-618.

† *Iron Trade Review*, vol. xlii. pp. 65-69.

‡ Paper read before the Pittsburg Foundrymen's Association; *Iron Trade Review*, vol. xli. pp. 626-627.

with pig iron made in casting machines, with special reference to their subsequent use in the foundry. The machine-cast pig iron is less variable in quality, the iron being collected in a ladle which acts as a mixer, and reduces the cast to greater uniformity of composition than under the old method, apart from the fact that it does not introduce sand into the cupola. Sand-cast pig iron, on the other hand, introduces about 30 lbs. of sand per ton of pig iron, while it is also apt to be lower in carbon than the machine-cast pig.

Recovery of Iron from Cupola Slag.—R. Grimshaw* describes a magnetic process for the recovery of iron from the slag of cupolas. The iron should be recovered from comparatively fresh slag, as if allowed to rust it would be impossible to employ a magnetic process. The process naturally only applies to iron admixed with the slag in the form of metallic particles. This often amounts to 9 or 12 per cent.

American Foundries.—H. C. Estep † describes the foundry of the Olympic Foundry Company at Seattle, Washington.

An illustrated description has appeared ‡ of the Browne and Sharpe Foundry, Providence, Rhode Island.

The plant and appliances of the Green Engineering Company, at their foundry and works, for the manufacture of mechanical stokers at East Chicago, are described and illustrated.§ The cupolas are respectively 48 and 98 inches in diameter, and the capacity of the foundry is about 60 tons of castings per day.

An illustrated description has appeared || of the gun-foundry of the Tredegar Iron Works, Richmond, Virginia. The shop is of historic interest from the fact that the guns and projectiles made for the Confederate Government during the civil war were made here. The foundry now produces general castings, and is served by two 30-ton cranes.

Chinese and Japanese Foundries.—Foundry practice in China and Japan is dealt with by H. Herland.¶ His paper deals chiefly with bronze casting, as cast iron is but little used for art metal-work in these countries.

Moulding Sand.—Moulding sand forms the subject of a paper by A. E. Outerbridge.** He considers the effect of simple mechanical treatment in securing increased toughness and porosity in moulding

* *Iron Trade Review*, vol. xlii. p. 32.

† *Foundry Trade Journal*, 1907, pp. 57-60.

‡ *American Machinist*, vol. xxx. pp. 941-944.

§ *Iron Trade Review*, vol. xli. pp. 872-876.

|| *Iron Age*, vol. lxxx. pp. 1057-1059.

¶ *Giesserei Zeitung*, vol. iv. pp. 164-168, 195-198.

** *Proceedings of the American Society of Mechanical Engineers*, vol. xxix. p. 131.

sand, and describes a number of experiments in testing and mixing such sand.

Green Sand Moulding.—G. H. Wadsworth* deals with foundry cores, core sand, and core-making machinery.

Machine Moulding.—The machine moulding of baths is described by H. Mamy.†

Details of moulding machines are given by E. H. Mumford.‡

Moulding machines, their patterns and their work, are described and illustrated in a lengthy article§ dealing with the iron foundry of the General Electric Company, Schenectady, New York. The equipment of the foundry comprises 216 moulding machines.

J. F. Hart|| describes the moulding of a ship's propeller in loam.

J. Kraus¶ has described very fully, with the aid of numerous illustrations, modern moulding machines as used in foundries.

An illustrated description is given** of a method of moulding curved cast-iron pipe vertically in dry sand.

E. H. Mumford †† gives an illustrated description of the methods employed in double ramming by the Bonvillain moulding machine.

Casting Iron in Metallic Moulds.—A new method of obtaining unchilled castings from metallic moulds was recently shown in operation.‡‡ It has long been known that by using suitable mixtures it was not difficult to get soft castings from iron moulds, the presence of a fair proportion of silica being sufficient to prevent the metal taking a chill. This fact has been made use of for some considerable time past at the works of Alfred Herbert & Co., where the smaller sizes of turret are cast in metal moulds. The castings are removed as soon as solid, and are notable for their soundness. The distinguishing feature of the new process, which is the invention of Charles Székely, will be found in the fact that no special mixture of iron is required, his claim being that, taking any ordinary foundry iron, he will obtain from an iron mould a casting better in every point of view than can be obtained from the same iron cast in sand. A feature of the process is the total absence of shrinkage, the castings being practically identical in size with the mould from which they are taken. They are further remarkable for their sharpness and excellent surface, and they require no dressing, being free from scabs and fins.

* *American Machinist*, vol. xxxi. pp. 74-75.

† *Génie Civil*, vol. lii. pp. 1-3.

‡ *Proceedings of the American Society of Mechanical Engineers*, vol. xxix. p. 509.

§ *American Machinist*, vol. xxx., Part II., pp. 667-671.

|| *Ibid.*, vol. xxx. pp. 580-582.

¶ *Stahl und Eisen*, vol. xxvii. pp. 1485-1491, 1536-1541, 1576-1581.

** *American Machinist*, vol. xxx., Part II., pp. 619-620.

†† *Iron Trade Review*, vol. xli. pp. 1006-1008.

‡‡ *Engineering*, vol. lxxxiv. p. 754.

Drying Ovens.—The arrangements for heating drying ovens are discussed by J. H. Zemek.*

Large Castings.—An illustrated description of a large casting for the half section of a flywheel has appeared.† The casting, which weighs 80,000 pounds, was made at the Payne and Joubert Foundry, Birmingham, Alabama. In pouring, it was necessary to take two heats from the cupola, the first being kept hot in the ladle by covering with charcoal while the second was being melted. The two ladles were poured at the same time.

Malleable Castings.—B. Stoughton discusses malleable castings.‡ W. H. Hatfield§ deals with the evolution and present position of malleable cast iron, and criticises the definition given by Howe. Malleable cast iron is a variety of cast iron having all the advantages of a casting with none of the disadvantages, and the early methods adopted for the production of malleable iron, and the gradual evolution of the processes until cast iron came to be produced, are described. Réaumur was the first to publish a method of making cast iron malleable by heating the castings in a bed of red oxide of iron. This was in 1722, yet, as recently as 1804, Samuel Lucas was allowed to take out a patent for the process, notwithstanding that it had been in use for so many years previously. Malleable castings are produced either by oxidising or eliminating the carbon of ordinary castings, or precipitating it in such a condition that it does not militate against the production of the qualities desired. Elimination is the method usually practised in Europe, while in America the black heart castings are usually produced by precipitating the carbon. The latter process was introduced in the early days of last century by Seth Boyden, in Newark, New Jersey. Special malleable iron possesses very high maximum stress, while its ductility far surpasses that of any other form of malleable iron.

Semi-Steel Castings.—D. M'Lain|| describes the manufacture of semi-steel castings made by increasing the amount of steel scrap charged in the cupola. A mixture for semi-steel is as follows: Selected pig iron containing 0·35 to 0·45 per cent. phosphorus, 0·025 to 0·035 per cent. of sulphur, and 1 per cent. of manganese, is used. If the silicon reaches as much as 2 per cent., 30 per cent. of steel can be carried, or more in proportion, an average composition of 1·65 to 1·75 per cent. of silicon in the mixture being aimed at. Manganese is then added in lumps to bring the percentage up to 2·0 to 2·5 per cent., about 1 to 2 per cent. being lost in the cupola.

* *Zeitschrift für Dampfkessel und Maschinenbetrieb*, 1907, pp. 425–426.

† *Iron Age*, vol. lxxx. p. 1615.

‡ *School of Mines Quarterly*, vol. xxix. pp. 54–62.

§ Paper read before the Institution of Engineers and Shipbuilders in Scotland, March 17, 1908.

|| *Iron Age*, vol. lxxx. p. 991.

The M'Haffie method of making steel castings, in use at the new plant of the Keystone Steel Castings Company, Chester, Pennsylvania, is described * and illustrated. The success of the process depends on the careful selection, proper mixing and melting of special grades of mottled and white iron, and subsequent special annealing, which converts the castings into semi-steel.

Cleaning Castings.—An illustrated description has appeared † of the Lunkenheimer improved sand-blast nozzle designed to decrease the heavy wear usually encountered by the outlet tube.

Cast-Iron Pipes.—W. B. Robinson ‡ describes the manufacture of cast-iron pipes as carried out at the new works of the United States Cast Iron Pipe and Foundry Company at Scottsdale, Pennsylvania. The pipes are manufactured by a continuous process, and the foundry is the largest pipe foundry in the world, having a capacity of 750 tons of pipe daily. The main foundry is 700 feet long and 125 feet wide, and the cupola house is situated at the middle of the west side of the main building. There are four 84-inch cupolas with melting capacities of 14 to 18 tons per hour, and four positive pressure blowers each connected with a 50 horse-power motor. There are four revolving tables each 47 feet in diameter, each table having a capacity of ninety-four double flasks for pipe up to 6 inches in diameter, or fifty-eight double flasks for 12-inch pipe, and each table weighs, with its flasks and pipes, 700 tons. The diameter of the pits in which each table revolves is 74 feet.

* *Iron Trade Review*, vol. xlii. pp. 71-74.

† *Iron Age*, vol. lxxx. p. 1465.

‡ *Iron Trade Review*, vol. xli. pp. 909-916.

PRODUCTION OF MALLEABLE IRON.

Direct Production of Wrought Iron.—G. Hofer * gives an illustrated description of a shaft-furnace for the production of spongy iron from a charge consisting of a mixture of ore dust and fuel (wood charcoal, coal, coke, &c.). The spongy iron absorbs gas, when gas is used for cooling, and is thereby protected against oxidation.

Decarburisation of Iron.—F. Wüst † states that, in the conversion of cast iron into malleable iron by heating in contact with iron oxide, the removal of carbon only begins after a decomposition of the carbide (cementite) into ferrite and carbon (temper-carbon) has taken place. By experiments with a cast iron containing 4.15 per cent. of carbon, 3.45 per cent. of which was in the form of temper-carbon, it was found to be immaterial whether the iron was in contact with the ferric oxide or not. By exhausting the apparatus and analysing the gases formed from time to time it was found that the oxidising agent is oxygen, evolved by the ferric oxide at 1000° and upwards. This oxygen diffuses into the iron, forming carbon dioxide, which then diffuses further, being converted into carbon monoxide by the temper-carbon in the interior. This carbon monoxide is re-oxidised by the ferric oxide, ferrous oxide and metallic iron being produced. Should the quantity of iron be insufficient, the pressure of carbon dioxide may rise to such an extent that the process is reversed, the outer layers of iron being carburised by the decomposition of the carbon dioxide. This explanation of the process is confirmed by the microscopic examination of the outer and inner layers of the mass of iron.

Gustav Hofer ‡ deals with the production of malleable iron from pig iron poor in phosphorus and rich in silicon. The successful working of the basic steel process requires a pig iron with at least 1.8 per cent. phosphorus and at the most 1 per cent. silicon. If it be desired to treat an iron poor in phosphorus by the basic Bessemer process, the place of phosphorus must be filled by silicon, and this causes various disadvantages which render the process unprofitable—for instance, the increase in the addition of limestone, the low percentage of phosphorus in the slag, and its consequent reduced value and the increased attack of the basic lining of the converter.

* *Giesserei Zeitung*, vol. iv. pp. 677-679.

† *Metallurgie*, vol. v. pp. 7-12.

‡ *Giesserei Zeitung*, vol. iv. pp. 481-482.

Massenez proposes the following modification of the process when making pig iron rich in silicon. At first basic additions, such as limestone, oxide of iron, manganese oxide, are charged in such quantities that they form a sufficiently fluid slag with the silica formed by oxidation of silicon at the beginning of the blast, and also with the manganese oxide originating from the burning of the manganese present; this slag is tapped as soon as the silicon contained in the pig iron is entirely or for the most part burnt, which happens one or two minutes after the appearance of the carbon flame. The quantity of the addition required for the formation of the first slag depends upon the percentage of silicon originally contained in the pig iron; the resulting slag should, however, indicate a sufficient percentage of silica to prevent the slag from absorbing larger quantities of phosphoric acid. For this reason the slag should not contain less than 30 per cent. silica. The first slag is tapped off as rapidly and as completely as possible. After tapping this slag the necessary quantity of limestone is added to the bath of metal for binding the phosphoric acid formed during the continuation of the process and for removing the injurious effect of the silica, which forms by the burning of any silicon of the first slag remaining in the bath of metal, and of the remaining acids of the first slag, which may have remained in the converter. After this addition has been made the blast is continued, and the charge after the burning of the phosphorus is finished in the usual manner.

Danks Puddling Furnace.—J. G. Danks* comments on the Roe puddling process, and gives an historical review of the development of mechanical puddling, with special reference to the Danks rotary furnace. The construction of the furnace, the methods of working the process, and the nature and quality of the product are discussed, and the formation of blisters and the question of bleeding are briefly referred to.

Electric Smelting of Iron.—Some problems connected with the electro-thermic production of iron and steel are worked out in detail by J. W. Richards.†

The results of an investigation of the effect of high pressure upon electric-furnace reactions have been published by R. S. Hutton‡ and J. E. Petavel.

The electro-metallurgy of the ferro-alloys and of iron and steel is discussed by J. B. C. Kershaw,§ who gives illustrations of the leading types of furnace in use.

A. Stansfield|| describes the electrothermic production of steel from iron ore.

* *Iron Age*, vol. lxxx. pp. 1082-1083.

† *Journal of the Franklin Institute*, vol. clxiv. pp. 443-459; vol. clxv. pp. 47-58.

‡ *Proceedings of the Royal Society*, vol. lxxix., Series A., pp. 155-157; *Engineering*, vol. lxxv. pp. 259-262.

§ *Engineering Magazine*, vol. xxxiv. pp. 261-277.

|| *Journal of the Canadian Mining Institute*, vol. x. pp. 129-133.

J. von Ehrenwerth * discusses the present condition of electric iron smelting.

Some excellent illustrations of electric induction furnaces are given.† V. Engelhardt ‡ considers that the fundamental idea of such furnaces is due not to Kjellin but to Z. de Ferranti (British patent, 1887, No. 700).

A. E. Greene§ and F. S. MacGregor describe experiments made in the Technological Institute of the Massachusetts University which should contribute to the solution of the five following questions: (1) Design and construction of an experimental furnace having a capacity of 30 kilowatts; (2) measurement of temperature of the melted charge; (3) determination of the factors from which the temperature depends, and methods of regulating the same; (4) the influence of the temperature and the mixing of the charge on the quality of the iron recovered; (5) the calculation of the consumption of electric current per ton of pig iron. The iron ore used in the experiments had the following composition: Fe_2O_3 , 70.40 per cent.; SiO_2 , 1.99 per cent.; TiO_2 , 26.40 per cent.; small quantities of Al_2O_3 and MnO_2 , and no phosphorus and sulphur. The total percentage of iron was 52.52. The ore was broken to pieces of one quarter of an inch in size. The fuel was the best quality Pocahontas coke, and pure, freshly burned lime was used as a flux. Alternating current of 1100 volts was employed. The temperature of the melted iron was measured by means of a Wanner pyrometer, and that of the gases by a thermo-couple. The construction of the furnace was the following: A rectangular foundation plate $\frac{3}{4}$ inch thick, and measuring 24 x 28, was connected to one of the cables. Five iron screws, which were embedded in a carbon mixture, served further to lead the current to the hearth (a crucible). Around this were carborundum bricks, and the interior was built up of bricks. The tapping-hole for the melted metal was at one side of the furnace, and the tapping-hole for the slag at the opposite side, about 2 inches higher. The crucible served as one of the electrodes, and the other was formed by a block of graphite, which was adjustable vertically. The top of the furnace was fitted with a charging hopper. The gases were led away and collected for analysis. When the charge is melted the current increases rapidly, because then the current only serves for heating, the conductivity increases with the temperature, and the amperes increase from 660 to 810 in twelve minutes. During another experiment the kilowatts increased from 16.5 to 19.2. The temperature rose after one minute from 1204° to 1222°, and after two minutes remained constant at 1234°. This fact teaches the facility of regulating the temperature. The efficiency was on an average 92 per cent. The experiments consisted of six preliminary experiments and six principal experiments. The following table gives the results obtained:—

* *Oesterreichische Zeitschrift für Berg- und Hüttenwesen*, vol. lvi. pp. 1-4, 21-24.

† *Elektrochemische Zeitschrift*, vol. xiv. pp. 211, 256; vol. xv. p. 14.

‡ *Elektrotechnische Zeitschrift*, 1907, pp. 1051, 1084, 1104, 1124.

§ *Electrochemical and Metallurgical Industry*, vol. v. p. 367-371.

No.	Proportion CaO $\text{Al}_2\text{O}_3 + \text{SiO}_2 + \text{TlO}_2$	Silicon. Per Cent.	Titanium in Metal. Per Cent.	Iron in Slag. Per Cent.	Temperature. Degrees C.	Nature of Slag.	Electric Horse- power Year per Ton of Pig. Per Cent.
1	$\frac{2.25}{2.90}$	0.10	0.00	2.96	1376	Rather fluid.	1.14
2	"	0.11	0.00	7.10	1583	Fluid.	2.25
3	$\frac{3.50}{2.90}$	0.13	0.00	6.37	1540	Infusible, viscous.	0.97
4	"	0.23	0.00	7.56	1675	Infusible, viscous.	0.93
5	$\frac{0.75}{2.90}$	0.30	0.20	"	1922	Very fluid.	1.22
6	"	0.44	0.04	"	1469	Very fluid.	0.79

The reduction of silica increases with the temperature; the reduction of titanitic acid occurred only with very acid slag, and then increased with the temperature. The experiments cannot be considered as complete.

Special Processes of Electric Smelting.—In a series of articles* on the manufacture and use of ferro-alloys, drawings are given of the Girod furnace and the Keller furnace. Illustrations are also given † of the electro-metallurgical works at La Prâz, and of the Hérault furnace.

A. Grönwall ‡ describes the electric furnaces of Siemens, Ferranti, Stassano, Hérault, Girod, Lindblad, Kjellin, Hjort, Röchling, and Dolter.

New electric furnaces are described by W. von Molo. §

H. Wedding || describes a modified form of electric induction furnace, known as the Roechling-Rodenhauser furnace, which is at work at the Roechling Iron and Steel Works at Volklingen. The furnace is intended for the refining of molten steel from the basic converter so as to obtain from it steel of a quality equal to the best Swedish soft iron. The furnace employed differs from the older Kjellin design by combining with the ordinary heating by electric induction, currents which are introduced through the bath through metal electrodes, so that a double effect is brought about. A description of the furnace with illustrations is given in the paper. In its general design the furnace is built much like a tipping open-hearth furnace. The capacity of the furnace is from 3 to 3½ tons, but about 800 kilogrammes of metal are left in at the end of each heat, so that the new charge of steel introduced is about 2½ tons. Details of heating up the furnace, which is lined with magnesia, are given. When the charge of steel from the basic converter is introduced, burnt lime and a little fluorspar are added, and the operation is completed when no more bubbles rise up from the liquid metal, and when samples give satisfactory tests. The slag, which generally contains some 25 per cent. of iron in the form of oxide, is then removed, and a pure lime slag is formed by addition of more lime and fluorspar. By this means, aided by the addition of ferro-silicon, deoxidation of the bath is brought about. If it is desired to make high carbon steel, powdered coke is added, which quickly dissolves in the bath, otherwise spiegeleisen is added as usual.

The author gives an analysis of the final slag, which is remarkable for the high percentage of lime with low silica, viz. 67·82 per cent. of lime, and only 0·97 per cent. of silica, the ferrous oxide being 5·32 per cent. Sulphur can be removed by the aid of manganese and a

* *Engineer*, vol. cv. pp. 80-81.

† *Ibid.*, p. 105.

‡ *Teknisk Tidskrift, Afdelningen för Bergvetenskap*, vol. xxxviii. pp. 17-21; *Blad för Bergshantieringens Vänner*, 1908, pp. 188-207.

§ *Oesterreichische Zeitschrift für Berg- und Hüttenwesen*, vol. lvi. pp. 515-518.

|| *Stahl und Eisen*, vol. xxvii. pp. 1605-1612.

high temperature. When it is desired to lower the phosphorus under 0·02 per cent. it is necessary to remove the second slag, and form still a third one, similar to the second. A heat averages from two to three hours. Two men work the furnace, whilst a third attends to the electric equipment. As an example of the purification which can be effected, the author gives an analysis : (a) metal poured in, and (b) the metal tipped out :—

	a.	b.
Carbon	0·115	0·069
Manganese	0·519	0·348
Silicon	0·016	0·036
Phosphorus	0·079	0·013
Sulphur	0·081	0·060

Some examples of the physical quality of the steel produced are given :—

Tensile Strength. Tons per Square Inch.	Elongation.	Contraction.
	Per Cent.	Per Cent.
22·8	37	71
25·4	30	57
31·7	31	50
22·8	32	62
20·9	37	65

As regards the electric energy required, the current is regulated as desired. The amount required during a typical heat is given as follows :—

Time.	Volts.	Amperes.	Kilowatts.
10·50	2600	145·0	330
11·00	2800	150·0	365
11·10	3000	165·0	430
11·20	3000	165·0	430
11·30	3200	170·0	460
11·40	2800	152·0	375
11·50	2600	142·5	315
12·00	2000	142·0	330
12·10	2400	128·0	250
12·20	2400	130·0	270
12·30	2400	131·0	210
12·40	2400	131·0	210

Tapping was then begun, and after a new charge had been introduced, the current during charging was at 2600 volts, 40 amperes, and 80 kilowatts, and then rose to 130 amperes and 310 kilowatts. The figures show the power factor to be satisfactory. The author concludes by saying that this process, like all electrical steel processes, serves simply for refining. It enables the last traces of

impurity to be removed from the iron, and to introduce any wished for amount of carbon or other element into the metal. It especially serves, however, as a substitute for the crucible process, by removing all dissolved gases without the disadvantage of absorbing silicon from the crucible walls.

A. Schmid * contributes an article on the desulphurisation of steel in the Kjelin induction furnace, in which he contends that the desulphurisation which is known to take place under the high heat present in the electric steel furnace is not due so much to the high temperature and basic slag present as to the passage through the metal of the alternating current itself in presence of oxidising ores. He gives full details of several charges to prove his contention.

O. Thallner † describes the production of steel of high grade qualities in the electric steel furnace. He deals at some length with the ordinary commercial processes for the production of extra pure steel, and points out that the ordinary analyses made do not go sufficiently far to determine the real quality of the steel. He instances that when sulphur is estimated, it is not determined whether it is dissolved, or exists in combination with iron, or copper, or arsenic. Oxygen determinations are also of the utmost importance, and although it is generally recognised that dissolved oxides play a most important rôle, they are not determined. The author is of opinion that dissolved ferrous oxide is the chief carrier of hydrogen, and is the cause of this body alloying with iron. The effects of nitrogen are referred to, and the probability that this element is partly removed by escaping carbonic oxide gas is discussed. The author goes on to refer to the different conditions present in the basic-lined electric furnace as compared with the crucible process, in which it is possible for silicon to be gradually reduced from the lining and so play an important rôle in deoxidising the metal. He contends that the electric furnace must be considered as a different purifier to the crucible process. He considers the effect of the electric current to be due solely to its clean heating effect, and the desulphurisation obtained in the electric process to be due to the fresh slag that can be repeatedly formed and liquefied. Tungsten and molybdenum are capable of removing sulphur from the steel bath, and also when used in the crucible, the sulphides being volatilised from the slag. So long as the slag is rich in iron, desulphurisation is by no means complete, the sulphur passing readily back from the slag to the metal. The absolute control of the slag which is possible in the electric furnace is the cause of the great purification it is possible to bring about in such a furnace. The author describes the Héroult process, dividing it into three stages, the first in which the phosphorus is removed under conditions similar to the open-hearth furnace, carbon is reduced to below 0.10 per cent., and silicon and manganese are almost completely removed; the bath being at the same time somewhat over-oxidised.

* *Stahl und Eisen*, pp. 1613-1615.

† *Ibid.*, pp. 1677-1686 and 1721-1723.

The second period is a deoxidising period, and details are withheld. The third stage deoxidises the slag with the formation of calcium and silicon carbides, thereby freeing the slag from iron oxide and allowing it to retain sulphur. The desulphurisation takes place readily during this period, the sulphur being reduced to traces. Some details of the practical results obtained from the 1.5-ton Héroult furnace first erected at the Lindenberg works at Remscheid are given. A trial of 2337 charges (from four to ten a day) have been made from it, using both cold and molten metal indiscriminately. No important repairs have been necessitated, and the slag does not attack the furnace. Diagrams showing the consumption of energy when starting with cold and with molten metal are given, and many diagrams and other curves are given.

G. Gin * describes smelting experiments with titaniferous iron ores conducted in 1901 in Norway, and in 1906 in the laboratory of W. Borchers in Aix-la-Chapelle. Currents of 500 amperes at 65 volts were employed; the temperature rose to 1900°. Only two-thirds as much lime as titaniferous acid and as much lime as silica present are allowed. All the titanium present in the ore passed into the slag. Analyses of materials and products are given, and the conclusion drawn from the experiments is that the reduction of titaniferous iron ores in the electric furnace presents no special difficulties, and that from it pure iron can be obtained commercially in regions where the ore is situated near to abundant and cheap water-power.†

A description has appeared ‡ of an electric installation at Turin, where two furnaces of the Stassano type, each of 1000 horse-power, are in operation. These furnaces, one of which is rotary and the other fixed, are operated by a three-phase current, and have two three-phase arcs with six electrodes, the useful effect being, however, only 51 per cent.

An account§ is given of the results obtained by the use of the Stassano electric furnace at Turin. In the works there are in operation one revolving 200 horse-power furnace, another of 1000 horse-power on the same system, and three fixed furnaces, two 100 horse-power, and the other 1000 horse-power. The fixed furnaces, though lower in cost by a third, are only suitable for simple melting operations, such as are usual in the ordinary open-hearth furnace. The revolving furnaces cost respectively £800 and £2000, and are capable of producing 2.5 to 3 tons, and 16 to 18 tons per twenty-four hours. The fixed 100 horse-power furnace costs about £140, and produces about 1 ton every twenty-four hours. For working these furnaces three-phase current at 21,500 volts is taken from the public mains,

* *Transactions of the American Electrochemical Society*, vol. xi. pp. 291-293; *Electrician*, vol. lx. p. 295.

† *Transactions of the American Electrochemical Society*, vol. xi.; *Electrician*, vol. lx. p. 295.

‡ *Electricien*, October 12, 1907; *Times Engineering Supplement*, October 30, 1907, p. 6.

§ *Engineer*, vol. cv. p. 141.

and is transformed down to 80 volts for the 100 horse-power furnace, 100 volts for the 200 horse-power furnace, and from 100 to 150 volts for the 1000 horse-power furnace. The 100 horse-power furnace works on the single-phase system, and takes current up to 1000 amperes. The 200 horse-power furnace is three-phase, while the 1000 horse-power has six electrodes and takes 1800 amperes on each phase.

FORGE AND MILL MACHINERY.

Forge-hammers.—Frank Richards * states that if hammers are only used intermittently, there is a great advantage to drive them by compressed air. The loss of heat employed to warm the hammer each time it is used is avoided, and with compressed air the hammer is always ready for use. It is further recommended to drive hammers by compressed air when the boilers are situated a long distance away, because the losses of heat and pressure in the long pipe line are considerable. The disturbing and often dangerous dropping of condensed water does not exist with compressed air. With compressed air lubrication is more simple, and the oil mixed with the air covers the walls of the cylinder with a coating of grease, while steam thoroughly removes the oil from the walls of the cylinder. For this reason the wear with compressed air is considerably less. The author also shows that from an economical point of view the use of compressed air is advantageous.

Forging-presses.—Illustrations of forging-presses are given by O. Bräcke.†

Recent improvements in the construction of steam-hydraulic presses are described by Peter.‡

H. F. Lichte§ describes several forging presses. 1. A horizontal Ajax forging press principally for nuts, bolts, and rivets. The power required varies with the size of the machine from 8 to 30 horse-power. 2. A special rivet-forging press with automatic feed, capable of producing in ten hours about 5 tons of $\frac{3}{4}$ -inch rivets 2 inches long. 3. A hot press for the manufacture of square or hexagon nuts from flat bars. The power required varies with the size of the machine, and amounts to 10 horse-power for nuts measuring $\frac{1}{2}$ inch over the flats, 20 horse-power for nuts measuring 1 inch, and 30 horse-power for nuts measuring 2 inches. 4. A forging and bending machine, which is capable of dealing with forgings which can only be bent with great difficulty under the hammer. Such machines can exert a pressure of from 3 to 500 tons. 5. A forging and rolling machine which is

* *Compressed Air*, 1907, p. 4527.

† *Bihang till Jernkontorets Annaler*, 1907, pp. 670-681.

‡ *Glaser's Annalen*, vol. lxi. pp. 153-157.

§ *Giesserei Zeitung*, vol. iv. pp. 552-556.

designed for cutting out axles and also for conical and oval forgings. The power required is from 15 to 30 horse-power.

An illustrated description has appeared * of the works of the Leeds Forge Company.

The largest hydraulic press yet made, a bending machine for armour plates, has been ordered by the firm of Krupp from the Duisburg Engineering Works. †

Electricity in Rolling-mills.—An illustrated description has appeared ‡ of an electric motor used for driving a 30-inch universal plate-mill at the works of the Illinois Steel Company, South Chicago. The installation is somewhat novel, as a small motor is made to drive the rolls during the passes by utilising the stored energy of a heavy flywheel, the diameter of which is 13 feet 2 inches, having a total weight of 200,000 lbs.

H. Crowe § describes the equipment of the electrical portion of reversing-mills. The brushes of the reversing-mill motor are directly coupled to the brushes of the generator of an Ilgner converter set. The armatures of the generator and the mill motor are protected against excessive currents by an automatic circuit break inserted in the cable connecting these two armatures, and these machines are further protected by a no-voltage release in connection with the fields of the mill motor, so that if for any reason these motor fields are not excited the connection between the armatures of the generator and mill motor are opened. The current required for exciting the field magnets of the mill generator and the reversing-mill motor is obtained from a special exciter set; the mill is controlled by a single lever operating the controller. It is convenient to be able to run the mill at a greater number of revolutions than that corresponding to the maximum torque, and this is effected by the operator pulling the controlling lever still further over. In large rolling mills the power required may vary from 0 to 10,000, or even 15,000 horse-power in either direction, but these great powers are not required for long periods, and to attempt to drive a mill of such powers without the aid of some system which would average up the power would be practically impossible; such great fluctuating loads would have disturbing effects on any power station, and the cost of the power station would be prohibitive had it to be made large enough to provide for the heaviest loads. By the use of heavy flywheels running at high speeds, a great amount of energy can be stored up and readily given out again. In order to take energy out of a flywheel, the speed must be allowed to fall, and therefore a constant speed motor will not share its load with the flywheel, and some arrangement is necessary whereby, as the motor falls in speed and the current taken from the power station shall not

* *Syren and Shipping*, vol. xlv., Supplement, November 6, 1907, pp. 6-7.

† *Chemiker Zeitung*, vol. xxxii, p. 522.

‡ *American Machinist*, vol. xxxi, pp. 51-54.

§ *Proceedings of the Cleveland Institution of Engineers*, April 8, 1908; *Iron and Coal Trades Review*, vol. lxxvi, pp. 1398-1399.

exceed predetermined limits, the method of slowing down the speed of the motor can be done in direct-current motors by suitably compounding the fields, and in an induction motor by inserting resistance in the motor winding. The resistance consists of metal plates suspended in earthenware tanks containing water, and the position of these plates regulates the amount of resistance. The liquid forming the resistance is kept cool by means of a series of cooling pipes placed in the tank through which a continuous stream of cold water is circulated. Special precautions have to be taken to make the generator and the mill motor run sparklessly with the brushes in one fixed position.

An advantage of the electrically-driven mill is the small stand-by loss. When the mill is shut down there are no losses of any kind going on, and in starting up all the time required is, say, ten minutes to run the converter up to speed. The disadvantages of the electrical reversing-mill are the high capital expenditure, and the electrical losses between the motor driving the flywheel converter and the mill motor. There appears to be no inducement to any firm who have to produce their electricity by burning coal directly under boilers to instal a special power station to drive a mill or even two mills. The great advantage of electric rolling, in fact the greatest advantage of all, is the generation of all the power required for the whole works in one large central station. In a works consisting of several rolling-mills these mills must necessarily be situated some distance from each other, sometimes so far apart as to necessitate separate boiler installations, and under these conditions there can be no doubt of the great advantage of centralising all the power. The cost of running all the auxiliary machinery is much reduced. At Teschen, where the first electrical reversing-mill was put to work, the number of boilers was reduced from 54 to 17. In Germany electrically-driven mills have made more rapid progress than in England, partly owing to the fact that coal is dearer and partly because the rolling-mills work in conjunction with blast-furnaces which produce large quantities of electricity very cheaply with the aid of the gas-engine.

W. T. Dean * investigates the conditions under which electricity is applicable for driving rolling-mills. The first heavy rolling-mill at which the electric drive has been adopted in the United States is at the Edgar Thompson works of the Carnegie Steel Company. The system used (250 volts direct current) is probably the most expensive in first cost and in operation that could have been selected. Nevertheless the installation has been a notable success from the beginning. The use of blast-furnace gases for generating electricity is considered, and the mathematical aspects of the problem given, while a description of the 6000 horse-power induction motor for the Indiana Steel Company is also given, and illustrations shown. The following conclusions are arrived at: (1) The electric drive is absolutely trustworthy, and (2) alternating current motors and transmission system should

* *Iron Trade Review*, vol. xliii. pp. 57-64.

be used; (3) a frequency of 25 cycles per second is preferable: (4) when blast-furnace gas is available a gas-engine plant yields the greatest amount of power; (5) a boiler plant with steam-turbines only produces four-fifths of the power generated by the same amount of fuel used in a gas-engine plant; (6) the trustworthiness of a steam-turbine plant outweighs this advantage, and (7) the saving in cost of a steam-turbine plant is much greater than that of a gas-engine plant; (8) it is more economical to generate electricity at the source of gas supply and to transmit it to motor-driven mills than to burn the gas under boilers at the mill, and finally (9) the electric drive is the most economical system in every case excepting where coal must be burned under boilers at the mill, and in this approximately double the power can be obtained from a given amount of steam by using low pressure turbines in the exhaust from mill engines.

K. Maleyka * describes the electric equipment of the *Rasselstein ironworks*.

Rolling-mills.—Illustrations have been published of a cogging-mill constructed for the Imperial Japanese steelworks.†

Illustrations of rolling-mills for tires are given by O. Bräcke.‡

Several new rolling-mill plants in the United States have been described. For instance, an illustrated description has appeared of the new Saucon plant of the Bethlehem Steel Company, Bethlehem, Pennsylvania.§ It comprises a rail mill, and a Grey structural and beam mill. The rail mill is a 28-inch mill, the Grey universal beam mill is a 48-inch mill, and the structural mill a 28-inch mill. The two 28-inch mills are served by a 40-inch blooming-mill furnished with a 800-ton hydraulic up-cut shear. The 28-inch rail mill consists of three stands of three-high rolls and two stands of three-high pinions. The Grey mill installation consists of a 46-inch blooming-mill and two 48-inch Grey beam mills, all three mills being arranged tandem for continuous rolling of the ingot without reheating.

The new rail mill of the Illinois Steel Company at the South Shore works, South Chicago, is described || and illustrated. The main building is 60 feet wide and 346 feet long, and the finishing department 45 feet wide and 360 feet long. The heating furnaces are very large, two of them being 17½ feet wide and 25 feet long, and one larger furnace 17 feet wide and 35 feet long being provided. Their special construction is described. The roughing, intermediate, and finishing trains of rolls are each of the three-high type with 24-inch rolls. The mill can roll rails from small sections up to 85-pound standard section, from either re-rolling sections or from 8-inch blooms. The entire machinery of the mill, with the exception of a few hydraulic machines, is electrically driven. There are four three-phase induction 25-cycle

* *Elektrische Kraftbetriebe und Bahnen*, 1907, pp. 665-672.

† *Zeitschrift des Vereines deutscher Ingenieure*, vol. lii, pp. 37-39.

‡ *Bihang till Jernkontorets Annaler*, 1907, pp. 670-690.

§ *Iron Trade Review*, vol. xli, pp. 735-745.

|| *Iron Age*, vol. lxxx, pp. 1634-1637.

2200 volt Westinghouse motors, two of 1200, and two of 600 horsepower each. When the rail mill is in full working order it will have an output of 10,000 tons of rails per month, operating on re-rolling sections.

An illustrated description * has appeared of the Tredegar Iron Works, Richmond, Virginia. It was established in 1836, and the entire plant is at present driven by water-power. During the Civil War it supplied the Confederate army with war materials. In the bar mill, which is an ordinary 18-inch mill, the iron plating for the frigate *Merrimac* was rolled.

F. E. Abbott † discusses rail-mill practice from several standpoints, including that of cambering, the chemical composition of the steel, the amount of discard, the application of the drop test, the selection of the rail section, shrinkage, cold straightening, the classification and causes of rail failures, and the suggested modifications in section to be introduced to avoid or remedy such failures. The endeavour is to regulate the cambering so that the rails will cool as nearly straight as possible, but as absolute straightness is almost impossible to attain, they are preferable brought when cold to a slight back sweep. The reason for this is so that cold straightening work will be done mainly on the base, therefore avoiding indentations on the head of the rail, and that the internal stresses in the rail after it becomes cold keep the joints up, and maintain a better track surface when the rails are in use. The chemical composition of steel rails is still a debatable point. Users are inclined to increase the carbon requirements somewhat faster in proportion than the increase in weight of section, in order to get more elasticity and better wear. These properties are, to a certain extent, obtained by these means, but failures from breakage become more frequent. To remedy this, users seek to lower the phosphorus, so that it shall not exceed 0.085 per cent., but this is not practicable owing to the ore conditions obtaining in the United States, and is opposed by the makers, who seek to maintain the phosphorus limit at 0.10 per cent., and to modify the percentage of carbon. The phosphorus limit is thus fixed by actual conditions, while the corresponding carbon limit must be fixed by experience. A harder steel might be used if the section were altered. The influence of sulphur, silicon, and manganese is briefly considered, and the amount of discard next considered. The question of more discard after enough of the ingot has been discarded is a purely economic question involving margin of safety, and should be left for settlement between the makers and the railways. The use of a drop test applied to a portion of the rail from the end towards the top of the ingot is commended as a satisfactory means of ascertaining both freedom from pipe and goodness of material. The relative advantages of various sections are discussed, the advantages of a balanced section with comparatively thick base being summarised.

* *Iron Age*, vol. lxxx, pp. 1057-1059.

† *Ibid.*, pp. 1380-1384.

The first Canadian mill* to turn out tinplates started operations at the end of December. This plant is situated at Morrisburg, Ontario, and its construction was commenced early in 1906.

Suggestions are given † as to the best conditions for rolling nickel sheets. The slabs should be rolled hot to about $\frac{5}{8}$ inch, then scraped on an overhauling machine, and finally finished cold. The best temperature for rolling is 1350° C.

Rolling-mill Scale.—The Pawling and Harnischfeger two-motor bucket grab hoist for rolling-mill scale is described ‡ and illustrated. It is in use at the Wisconsin Steel Company's works, South Chicago. The scale separated during rolling falls into a sluiceway under the rolls, and is washed thence into a concrete pit, where it settles, the water flowing away. It is to raise it from this pit that the grab bucket is employed. It has a bucket capacity of 15 cubic yards, and is operated from a special 3-ton electric travelling hoist.

Rolling-mill Engines.—F. Luhr§ describes a 1200 horse-power compound engine for driving a wire-rod mill.

G. Hooghwinkell,|| in a paper read before the Sheffield Society of Engineers and Metallurgists, discussed the driving of three-high mills by steam-engines, by gas-engines, and by electric motors, giving details of cost. The advantages to be obtained from electric driving are summarised, and the driving of reversing-mills is considered.

An exhaustive paper dealing in a practical manner with the question of steam versus electrical power for reversing-mills has been published by W. Schömburg.¶ The first cost of the two plants are compared, the actual cost of the various items being given. In the case given the cost of the electric plant works out to two and a quarter times as much as the steam plant. The author then deals in similar detail with the actual rolling cost per ton of steel. Under the conditions stated in the paper, and with good clean gas for the gas-engines, the electric rolling is somewhat cheaper per ton.

A notable rolling-mill engine** has recently been built for the Carnegie works of the United States Steel Corporation that ranks among the largest reciprocating engines ever built. It is a horizontal twin tandem engine, with 42-inch and 70-inch by 54-inch cylinders, designed for operating condensing with steam at 175 lbs. and for a maximum speed of 200 revolutions per minute, at which speed it has a maximum capacity of 25,000 horse-power. The engine erected has a total weight of 550 tons, and some of the individual parts are very

* *Engineering*, vol. lxxxv. p. 100.

† *Brass World*, New York; *Iron Age*, vol. lxxx. p. 1143.

‡ *Iron Trade Review*, vol. xii. pp. 628-629.

§ *Praktische Maschinen-Konstrukteur*, 1908, pp. 17-19.

|| *Electrician*, vol. lx. pp. 672-74.

¶ *Berg- und Hüttenmännische Rundschau*, vol. iii. p. 33 et seq.

** *Engineer*, vol. cv. p. 219.

large, two of the frame castings weighing, after machining, 118 tons each, and requiring special waggons for their transportation.

The use of thin steel bands is advocated * for the transmission of power in place of the belts or ropes usually employed. These bands have been successfully applied by the Eloesser Company of Charlottenburg.

* *Zeitschrift des Vereines deutscher Ingenieure*, vol. li. p. 1967.

PRODUCTION OF STEEL.

CONTENTS.

	PAGE
I. The Carburation of Malleable Iron	348
II. The Open-Hearth Process	349
III. The Bessemer Process	353

I.—THE CARBURISATION OF MALLEABLE IRON.

Crucible Steel.—A. Solovieff * describes the preparation of crucibles at the Ischeffski steelworks.

Crucible Tongs.—A. A. Johnson † points out that the life of a crucible is influenced largely by the handling and second only in importance to the annealing, and the first heating is the fit of the tongs and the kind of tongs used. There are three general styles of tongs in use—one-pronged tongs, two-pronged tongs, and spade tongs. These three styles may be either of the ring pattern, or of the grab pattern which he describes and illustrates. One-pronged tongs may be satisfactorily used on small crucibles only, but for sizes above No. 40 two-pronged tongs should be universally used. In some of the recent designs of oil furnaces tongs of the grab pattern are used with the handles above the ring bent over at right angles. As there are no ashes or fuel to contend with in the oil furnace, the tongs go right to their place without effort, and the bent handles allow the operator to stand off to one side.

History of Steel.—C. Benedicks ‡ contributes a note on the history of steel. Torbern Bergman of Upsala was the first to ascribe the difference between wrought iron, steel, and cast iron to variations in the percentages of carbon present (1781). By oxidising these metals he succeeded in isolating "seric acid" (carbon dioxide), and the limits he assigned to the three types of iron were 0.05 to 0.20

* *Gorni Journal*, 1907, pp. 149-158.

† *Iron and Coal Trades Review*, vol. lxxvi. p. 46.

‡ *Revue de Métallurgie*, vol. v. pp. 5-8.

per cent. for wrought iron, 0·2 to 0·80 per cent. for steel, and 1·00 to 3·00 per cent. for cast iron, and it was not until Bergman's observations had been published that accurate views as to the nature of steel became possible. As the result, however, of the editing of a hitherto unpublished manuscript by Linnæus entitled *Pluto Svecicus* (1734), the oldest manuscript written by him, dealing with the mineral kingdom, in which steel is defined as being iron devoid of sulphur, and the collateral research to which the preparation of this manuscript led, an old and forgotten French work was found, bearing earlier observations on the subject. At the epoch involved two theories of steel were current, one that it contained more "sulphur" than iron, and one that it contained less. It should be remembered that the term "sulphur" was, in those days, extended to any combustible matter, and is used, in the manuscript by Linnæus alluded to, not only for sulphur, but for asphalt and coal likewise. The two views given above therefore resolve themselves into—(1) that steel is iron containing an inflammable substance, and (2) that steel is iron deprived of inflammable substance. The divergence of these views is to be accounted for by the opposite points of view from which those who were employed in making iron from its ores, and those employed in making steel, by cementation, approached the subject. It is interesting, therefore, to find very correct views of the question at issue set forth in this old French work. It was published anonymously, at Strasburg, in 1737, and is entitled *Traité sur l'acier d'Alsace, ou l'art de convertir le fer du fonte en acier*. Indications point to its having been the work of the elder brother of Gilles Bazin, a physician of Strasburg, and the reputed author of several works on natural history. Enlightened views of the nature of steel are expressed, and a distinction is drawn between "natural steel" made directly from pig iron, and "artificial steel" made from wrought iron by cementation, the remarks on hardening being worthy of attention. The estimation in which the treatise was once held is shown by the fact that it was translated into Swedish in 1753.

II.—THE OPEN-HEARTH PROCESS.

New Open-hearth Steel Plant.—An illustrated description* has appeared of the new open-hearth plant of Monks, Hall & Company. A 25-ton basic furnace has been built adjoining the 10-inch mill. The main feature is the adaptation of the plant for either Mond gas or ordinary producer gas in the melting operations. The furnace itself is of a new type; while nominally of 25 tons capacity, it is so constructed that it can be converted into a 40-ton furnace should it be desired. The furnace bath is 25 feet by 10 feet 6 inches, lined with magnesite, and is of the ordinary basic type. The regenerative chambers are of the outside type, the gas and air chambers

* *Iron and Coal Trades Review*, vol. lxxvi. pp. 529-530.

being 8 feet by 25 feet, and 9 feet by 25 feet respectively. Very large slag pockets, 8 feet by 9 feet, are provided. The furnace is intended for the casting of very small ingots and the ingot moulds are of ingenious design, and so far as their use in this country is concerned, unique. In the case of the 4-inch ingots, it is possible to cast 40 on one plate. The smaller sizes are twin moulds, the 8-inch size being single moulds.

An illustrated description has appeared * of the Blair port, first installed experimentally in one of the old type furnaces at the Lackawanna Steel Company's plant. The whole end block, ports, and downtakes are built of ground magnesite mixed with 15 per cent. of basic slag and enough coal tar to bind it. The gas port is water-cooled, and the buckhead is a water-cooled box of $4\frac{1}{2}$ -inch brick lining, swung on hinges so as to be readily opened like a vault door at any time between the heats. The furnace to which it was fitted has already run nearly double the number of heats it did on ordinary brick ports.

An illustrated description has appeared † of a movable slag pocket designed to avoid the loss of time experienced in removing slag from the pockets of an open-hearth furnace in the usual way, during a shut down for repairs. It consists of a truck resting on rails laid at the bottom of the air or gas ways, and forms a receptacle for slag and dust carried out from the furnace hearth by the waste gases.

Open-hearth Steelworks in Austria.—A description has been published ‡ of the Skoda works at Pilsen. The new works have been put down on a large open space to the south of the city. They consist mainly of gun-shops for the construction of all calibres and classes of guns, their carriages and mountings, turrets, and for the manufacture of projectiles; of an open-hearth steelworks, mostly used for the manufacture of steel castings; and of an engineering works and cast-iron foundry, with which are connected bridge-building and boiler-making yards. The various shops cover an area of 10 hectares (24·7 acres).

A description of the modern Austrian steelworks has been published by T. Naske.§ A full account of the various departments in the Witkowitz works is given, including descriptions of the large press, and the special machines for the manufacture of shells. The Trzynietz works, which have been completely remodelled, and are at present the most important to metallurgists, owing to the installation of electrically-driven mills, are fully described. The process adopted at these works for the agglomeration of the small powdery ore, which is said to remove nearly all the sulphur, is explained, and a description is given of the new open-hearth steel plant. The Kladno works are also described. At these works the ores used are

* *Iron Age*, vol. lxxx. pp. 1310-1311.

† *Iron Trade Review*, vol. xii. pp. 795-796.

‡ *Engineering*, vol. lxxv. pp. 298-301.

§ *Stahl und Eisen*, vol. xxvii. pp. 1645-1652, 1656-1692, 1728-1736.

previously calcined in kilns, waste coal from the coal-washers being used for this purpose. The calcined ore is then treated in a very interesting manner for the removal of sulphur, by a method resembling to some extent the lixiviation method used for copper ores. After treatment the ore contains about 0·2 per cent. only of sulphur. In the account of the Königsberg works an interesting description of a mechanical puddling furnace is given.

Open-hearth Steelworks in Germany.—A description,* with illustrations, of the new steelworks at Bochum (Westphalia steelworks) has been published. The new open-hearth department commenced operations in January 1907. There are five open-hearth furnaces of from 40 to 50 tons capacity, served by suitable electric travelling and charging cranes. The furnaces are 10 metres long by 3·5 metres wide. The producer plant consists of twelve continuous Morgan producers, built in a line, each capable of gasifying from 8 to 10 tons in twenty-four hours.

A very full description of the new Friedrich-Alfred works at Rheinhausen has been published.† The description is accompanied by some sixty woodcuts showing views of the various parts of the works, together with plans and sections. The works were commenced about 1896, and from 1896 to 1898 three blast-furnaces each of 400 cubic metres capacity were erected; from 1903 to 1905 three more blast-furnaces each of 600 cubic metres capacity, together with steelworks and rolling-mills, were erected. In the year 1906 a fourth blast-furnace of 600 cubic metres capacity was erected. The works at present, therefore, comprise seven blast-furnaces with a yearly production of about 700,000 tons, a steelworks with four converters each of 25 tons capacity, a rolling-mill with two cogging and six finishing trains, with all the necessary appurtenances. The three old smaller blast-furnaces produce chiefly Bessemer and hæmatite pig for the use of the Essen works and the other Krupp works (Grusonwerk, Germaniawerft, the Annen steelworks and the Sayn works). The four new larger furnaces serve to supply the basic steelworks. The yearly requirements of iron ore reach about 1,600,000 tons, about half of which is water-borne and half conveyed by rail.

The briquetting plant, the production of which is given at 40,000 briquettes per twenty-four hours, equal to about 50,000 tons per annum, is also described.

H. Groeck ‡ gives an illustrated description of Krupp's Friedrich-Alfred steelworks at Rheinhausen.

Open-hearth Steelworks in Canada.—F. E. Lathe § describes the basic open-hearth steel manufacture as carried out by the Dominion Iron and Steel Company at Sydney, Cape Breton. The

* *Stahl und Eisen*, vol. xxviii. pp. 113-116.

† *Ibid.*, vol. xxvii. pp. 1445-1462.

‡ *Zeitschrift des Vereines deutscher Ingenieure*, vol. lii. pp. 91-98.

§ *Journal of the Canadian Mining Institute*, vol. x. pp. 373-398.

ore used in the blast-furnaces is a siliceous hæmatite yielding pig iron containing 3·75 per cent. of carbon, 1·10 per cent. of silicon, 1·40 per cent. of phosphorus, 0·03 per cent. of sulphur, and 0·30 per cent. of manganese. This pig iron is treated in an open-hearth steel plant consisting of ten 50-ton furnaces, eight of the Campbell type and two stationary, supplied by a 275-ton Campbell mixer, which holds molten metal from four blast-furnaces. The process of working a regular charge is described in detail.

Open-hearth Steelworks in the United States.—The new open-hearth furnaces of the Follansbee works, in West Virginia, are described * and illustrated. The old 25-ton furnaces have been pulled down and superseded by new furnaces of 35-ton capacity.

Steelworks Equipment.—Casting ladles and casting cranes for steelworks are described by F. Frölich.†

F. Frölich † states that the conditions required of casting appliances vary with the process. In the Bessemer process the ladle remains stationary during pouring; in the basic Bessemer process the height of the ladle, during pouring, must be varied to correspond with the sinking of the converter, and in addition the ladle must be moved laterally in the direction of the flow of metal. With the Talbot process the variation of the height and lateral position of the ladle while the furnace is being tilted have to be considered. The crane has the advantage of the more steady motion. With casting waggons the speed is limited by the danger of splashing molten metal. With cranes the speed can be increased by utilising the advantages of electric driving. The crane has the advantage of being able to perform other work. For very large furnaces of 50 tons and over, owing to the unwieldy proportions of casting waggons, electric travelling cranes are decidedly advantageous. Several different appliances for lifting plugs constructed by various firms are compared.

Casting waggons are constructed of two different types. In one of these types the ladle, in addition to the travelling motion of the waggon, has a cross motion, which does not go beyond the width of the waggon; these waggons can only serve a casting-pit situated between the rails of the waggon. In the other type of waggon the ladle is on an arm, which can pivot around a centre on the waggon, so that the ladle, in addition to the space between the rails, can serve a zone on each side of the track corresponding to the length of the arm. The waggons of the first type are only suitable for small open-hearth furnaces. Waggons of the second type are seldom constructed for capacities less than 20 tons. A description of several different casting waggons, manufactured by the leading German makers, is given.

C. Michenfelder § reviews the appliances formerly used to transport

* *Iron Trade Review*, vol. xli. pp. 953-954.

† *Zeitschrift des Vereines deutscher Ingenieure*, vol. li. pp. 1936-1941, 2051-2058.

‡ *Ibid.*, vol. li. pp. 1727-1736.

§ *Dinglers Polytechnisches Journal*, vol. cccxii. pp. 663-666, 679-683, 696, 726, 774, 792.

molten steel. With the introduction of the Bessemer process the so-called central crane was adopted. It was erected as a fixed radial crane in the centre of the circle occupied by the converter and the ingot moulds. The introduction of the basic Bessemer process, owing to the increased size and number of converters, and the consequent arrangement of the converters in a row, occasioned a complete change in the system of casting. The former radial motion of the ladle was changed to a straight line motion, and owing to the distance to be travelled the transport of the fluid metal was effected by a ladle on a travelling waggon. This has since been known as the casting waggon, and is an important auxiliary appliance of a modern basic steelworks. Economical requirements, extensive experience, and technical progress have brought the same to the present height of perfection. The author describes a steam hydraulic casting waggon constructed in 1880 for the Hörder Bergwerks- und Hüttenverein as a typical example of former practice. He then describes the construction of a modern steam hydraulic casting waggon, and deals with the electric casting waggon.

III.—THE BESSEMER PROCESS.

Wills Steel Converter.—An illustrated description* has appeared of the Wills steel converter in operation at the works of the Delaware and Lackawanna Steel Company. The steel can either be tapped from the bottom of the converter, or the vessel can be tilted and the metal poured in the usual way. In this converter the metal is given a rotary motion which not only burns out the silicon, carbon, &c., but frees it from gases and slag. The capacity is 8000 lbs. of steel, and the converter is 60 inches in diameter and 14 feet high.

The Flohr Addition to Bessemer Basic Charges.—An innovation in the carrying out of a Bessemer basic heat is being brought forward by J. Flohr,† steelworks manager at Rodingen, Luxemburg; it has been adopted by the Dudelange and the Ougrée-Maribaye Works and by the Rheinische Stahlwerke, Duisburg. The Flohr process, it is claimed, does away with the disadvantages attendant upon the use of lime or scrap additions. Lime thickens the slag and retards its power of absorption of phosphoric acid; moreover, a viscous slag retains iron particles readily, thus leading to a loss of metal, and the addition of scrap is conducive to a higher cost for the steel. Towards the end of the decarburising period, or later, to the bath is added a compound, made preferably in the shape of pressed briquettes, and formed of iron oxides, hammer cinder, or rolling-mill scale, with slacked lime as a binding medium. The briquettes have a rapid and decided effect on the metal bath, and upon their addi-

* *Iron Age*, vol. lxxx. pp. 990-991.

† *Engineering*, vol. lxxxv. p. 65

tion an after-blow of only a few seconds suffices to complete the operation. An addition of manganese ore to the briquettes proves advantageous in certain conditions, as it increases the liquidity of the slag, and thereby facilitates dephosphorisation. The analysis of a suitable cinder or scale is the following:—

	Per Cent.
Fine granulated iron	1
Ferric oxide	40·23
Ferrous oxide	53·06
Water	6

This is sifted and ground with quicklime. The calcium oxide combines with the water in the scale to form $\text{Ca}(\text{OH})_2$ with development of heat. By the addition of slacked lime to the mixture, the required percentage of hydrate of lime is obtained. On being stored for a short time the compound increases much in temperature and dries. After standing for three hours it shows the following analysis:—

	Per Cent.
Fine granulated iron	1·1
Ferric oxide	30·55
Ferrous oxide	47·90
Water	4·82
Carbon dioxide	0·6

After standing still longer—about three days—the compound is pulverulent, and the analysis shows:—

	Per Cent.
Fine granulated iron	1·06
Ferric oxide	31·40
Ferrous oxide	44·70
Lime	9·89
Water	4·16
Carbon dioxide	0·68

When, after a longer time, the transformation of calcium oxide into hydrate of lime is completed, briquettes are made of the compound, a press being used for this purpose. The specific weight of the briquettes depends upon the pressure exerted, but it has to be high enough to allow them to sink through the layer of slag in the converter, and to come in contact with the metal bath. In the Dudlange Steelworks, it is stated, a pressure of 80 atmospheres is employed. In order to render the briquettes less fragile they are dried in the open, or, preferably, in an oven. The analysis of the briquettes thus dried shows that the percentage of carbon dioxide—which in the compound amounted to about 0·65 per cent.—has risen to 1·3, thus tending to prove that in the hardening of the briquettes the occurrence is similar to that in the case of ordinary mortar exposed to the action of the atmosphere. As compared with the compound in a loose state, the proportions of ferric and ferrous oxides do not vary to a great extent. The briquettes contain:—

	Per Cent.
Ferric oxide	33·90
Ferrous oxide	42·06

The briquettes are thrown into the converter by hand or by a

mechanical device when, by inspection of the flame, the charge is deemed to be ready for the addition, and the slag liquid enough to allow them to reach the metal bath. The quantity added depends upon the conditions of working ruling at the time. All steel-makers are perfectly aware that very great variations constantly occur in the analysis of pig iron used for steel-making, and that the charge frequently becomes undesirably hot, which circumstances tend to increase the cost price of the steel, to increase also the waste by burning, the consumption of lime, and to reduce the value of the slag. In some cases it is necessary, in order to keep the price for raw material as low as possible, to work with a comparatively very low-grade pig iron, containing probably a high percentage of silicon, the oxidation of which in the converter leads to a greatly increased heat in the charge, which is unfavourable to dephosphorisation. In such cases the rapid cooling down of the charge by the addition of briquettes is found specially advantageous.

Small Bessemer Plant.—C. W. Carlsson * describes the preparation of steel castings with small Bessemer converters.

W. E. Koch † notes that the Tropenas converter has been installed at El Paso, Texas, and has added a new industry to the city.

Comparison of Bessemer and Open-hearth Processes.—W. M. Carr ‡ compares the advantages of the converter with those of small open-hearth furnaces for the manufacture of general steel castings. The balance is shown to be in favour of small open-hearth furnaces. The advantages of the 2-ton converter are: (1) It can be cheaply installed; (2) it can be started upon short notice and operated at irregular intervals; (3) it is well adapted for light sections; (4) it produces steel at such high temperatures that the metal presents few difficulties in handling; (5) the product is of good quality. On the other hand, advantage No. 2 is more apparent than real, as irregular operation is costly, and continuous operation is the keynote of any steel-casting method. This consideration influences the advantage noted under No. 3. The high initial temperature brings into play the personal equation in a marked manner, and the practised eye is the sole judge. If the blower's judgment is at fault from any cause heavy losses may result. The proper casting temperature being subject to eye measurement is more variable than that of open-hearth steel, and this constitutes a drawback. Finally the product, although good, is apt to be uncertain in quality.

Duplex Steel-making Process.—B. C. Lauth § gives a description and drawings of a new duplex steel process and proposed plant. The converters are placed at an elevation which permits of their dis-

* *Bihang till Jernkontorets Annaler*, 1907, pp. 659-670.

† *El Paso Mining Journal*, vol. i. p. 8.

‡ *Iron Trade Review*, vol. xli. pp. 792-793, 951-952.

§ *Iron Age*, vol. lxxx. pp. 1452-1454.

charging the blown metal into ladles on waggons at the level of the open-hearth charging platform, the arrangement of the rails over which these waggons travel being such that each furnace can be operated independently and without interfering with any other furnace. The same arrangements are also carried out in the casting pit, the product of each furnace being handled without regard to the work of any other furnace. The open-hearth furnace is specially designed to meet the conditions, a large tonnage with all the metal of the charge delivered molten and at a high temperament, free from silicon and having sufficient carbon to provide the necessary boil for dephosphorising and removing oxides. The furnace is very long, being 60 feet between ports, with a chilled bridge wall dividing it into two hearths of 30 feet in length each, so that two 60-ton heats can be finished with the same labour and approximately the same fuel as is ordinarily required for one 60-ton operation. The dividing of the 120-ton hearth is done with the object of reducing the cost of handling machinery, and to take advantage of the fuel economy derived from the adoption of very long hearths.

Experimental heats of 50 tons have been made in one hour and a half, and, allowing for delays, each furnace will produce about 960 tons per twenty-four hours. Assuming they produce only six heats a day, or 720 tons per twenty-four hours, the complete plant might be one of two 20-ton converters, with a third as a stand-by. With fifteen minute cycles this gives eight heats, or 160 tons per hour, or 3840 tons per day. Four 120-ton open-hearth furnaces, each divided into two 60-ton hearths, at six heats per twenty-four hours, give a production of 2880 tons daily. Such a plant would cost less than a third of the cost of a plant of the same capacity working on the ordinary open-hearth process. The process has been tried with satisfactory results at Lackawanna, a Blair indestructible port being used.

FURTHER TREATMENT OF IRON AND STEEL.

Case-hardening.—Illustrations are published* of a revolving gas-furnace adopted by the American Metal Treatment Company of Elizabeth, New Jersey, for case-hardening.

Annealing Furnaces.—G. Rietkötter† describes the ordinary types of annealing furnaces, both coal and gas fired. Sections of the various furnaces described are given.

A new process of annealing is described.‡ The steel to be annealed is heated in a chemically reducing, instead of an oxidising atmosphere. By this means the scaling of the surface of the bars to be annealed is entirely avoided. A small producer-gas plant is an essential part of the annealing installation, and the producer gas is led directly into the furnace, and is there mixed with the quantity of air necessary to support combustion. This process is said to give a uniform softness to the steel, and is carried out with a consumption of only 4 cwts. of coal per ton of steel annealed, as against nearly 1 ton of coal per ton of steel annealed in the ordinary furnaces. The complete process is accomplished in forty-eight hours.

Heat Treatment of Steel.—E. F. Lake§ describes the electric quartz furnace, invented by W. H. Bristol of New York, for the heat treatment of steel. The furnace consists of a quartz tube sealed at one end or open at both ends, wound with one or more layers of platinum or special base-metal alloy wire. The tube is covered to the depth of one inch or more with a refractory material, such as asbestos, clay, or cement, to retain the heat in the quartz in the centre. Quartz is admirably suited for the construction of furnaces of this description, as the temperature necessary to treat all steels can be readily obtained without affecting the tube either as regards softening or cracking.

* *American Machinist*, vol. xxxi. pp. 263-267.

† *Stahl und Eisen*, vol. xxvii. pp. 1652-1656.

‡ *American Machinist*, vol. xxx., Part II. p. 756.

§ *Ibid.*, vol. xxx., Part II., pp. 719-723.

Welding.—An illustrated description is given * of the repair by thermite of the stern-frame and rudder-post of the steamship *Corunna*, of the Canadian Lake Navigation Company.

A. I. Graham † gives an outline of the aluminio-thermic welding process, and notes some of its applications.

E. Wiss ‡ describes the operations of welding and cutting steel with the oxyhydrogen flame. Steel is cut in the following manner. The plate is heated locally by the oxyhydrogen flame to the temperature of burning, then a fine jet of oxygen under high pressure is directed to this point, the plate is bored through, and the burnt particles of iron are blown out. The hand-cutting apparatus made by the author consists essentially of a tube for hydrogen and one for oxygen, a reducing valve for hydrogen, two reducing valves for oxygen and the hose, through which the gases pass from the reducing valves to the burner, which is directed by hand. The front portion of the burner is provided with a small carriage, in order that it can be well guided. The blowpipe is between the carriage, and is so arranged that only a small portion of the object to be cut is heated, and that the oxygen is blown at a definite pressure and with a definite form of jet. The blowpipe consists of a central burner for oxygen and an annular burner for the heating gas. With the hand-cutting apparatus either straight lines or any form of curve can be cut out of the plate. The burner can also be moved forward mechanically, and the burner is advanced by a spindle. The author describes several applications of the process, and gives the cost of cutting plates from $\frac{1}{2}$ inch to 5 inches in thickness.

H. Schulze § describes the processes of welding with oxyhydrogen and with acetylene-oxygen, giving comparative details of cost.

J. Reischle || describes the application of autogenic welding for repairing steam-boilers.

V. A. Wrede ¶ deals with recent processes of welding steel and iron castings. Two processes have given good results in practice. One is the process of welding with thermite, the other consists of the application of the electric current. The first process finds practical application in the repair of heavy pieces, which are difficult to replace. The heating mass is thermite, a mixture of powdered aluminium and oxide of iron, which is fused in a suitable crucible by a special fusing mixture and match; in a short time this burns down completely and leaves a slag consisting of almost pure iron and oxide of aluminium, at the same time developing a temperature of about 3000° C. The iron from thermite has the same composition as cast steel, but it is at a much higher temperature than fluid steel in the open-hearth furnace. Small and larger quantities of thermite burn down with equal rapidity in from half to one minute. The author makes remarks of a general

* *Machinery*, vol. xiv. pp. 228-229.

† *Proceedings of the South Wales Institute of Engineers*, vol. xxv. pp. 427-438.

‡ *Anzeiger für Industrie und Technik*, 1907, No. 28.

§ *Zeitschrift des Vereines deutscher Ingenieure*, vol. lii. pp. 66-67.

|| *Zeitschrift des Bayerischen Revisions-Vereins*, 1908, pp. 23, 40.

¶ *Giesserei Zeitung*, vol. iv. pp. 622-628, 644-650, 676-677.

nature on the preparation of the mould, the moulding sand, and heating of the piece to be repaired, and describes several large repairs.

Elihu Thomson * gives a summary of the process, by which dissimilar metals may be welded. The Thomson system is adapted to repetition work, and the applications mentioned include carriage, bicycle, automobile, and machine parts, tools, hardware, tramway rails, chains, &c. The longitudinal seams of pipes up to 16 inches diameter are welded by rolling the sheet so that the edges meet, and passing them between the welding rolls. Thin sheets of metal can be welded together, and also the wires of netting in reinforced concrete.

C. B. Auel † describes a novel application of the Bernardos process of electric welding for the repair of defective steel castings.

Electric welding is described by F. Bock. ‡

Improvement of Quality of Steel Masses.—J. O. Arnold § concludes his exhaustive paper on factors of safety in marine engineering, read before the Institution of Naval Architects on April 10, 1908, with suggestive remarks on the improvement of the quality of large masses of steel.

The necessity of rejecting a sufficient weight of the upper part of a large ingot to insure the absence in the steel used for forging of liquated regions, pipes, and pockets, is too well known to need any remark; but even in the lower portions of such an ingot, presumably of good steel, it is practically impossible with a mean sulphur and phosphorus of 0.04 to 0.05 per cent. each to avoid some segregation areas, if the ingot be allowed to cool at atmospheric pressure; hence the production of some ghost-lines is inevitable; but if, as is sometimes the case, inferior steels containing up to 0.10 per cent. each of sulphur and phosphorus are accepted, the mischief is greatly aggravated. In the author's opinion in all heavily stressed engine parts the maximum phosphorus and sulphur should never exceed 0.05 per cent. each. Even with low sulphur and phosphorus it is desirable to reduce segregation to a minimum, and, so far as the author's knowledge goes, the only trustworthy and practical way to bring about this consummation is to cool the ingot under fluid compression, as long carried out by the Whitworth process or by recent developments of the original idea devised by Harmet and by Robinson and Rodgers, of Sheffield. But nearly one-third from the top of the Whitworth ingot there is a large bright cavity, or pocket, full of mixed gases, consisting chiefly of hydrogen and nitrogen, and in the vicinity of this pocket there is serious segregation, which is, of course, got rid of by cutting away the upper part of the ingot well below the pocket. The Whit-

* *Western Electrician*, vol. xli. pp. 245-246.

† *Electric Journal*, January 1906; *Engineering Magazine*, vol. xxxiv. pp. 1059-1061.

‡ *Zeitschrift des Bayerischen Revisions-Vereins*, 1907, pp. 215-218; *Zeitschrift des Oesterreichischen Ingenieur und Architekten Vereins*, vol. lix. pp. 841-844.

§ *Engineering*, vol. lxxxv. pp. 565-566, 598-601.

worth ingot is exceedingly clean, this fact conducing to sound forging, and it is relatively free from segregation compared with a similar ingot allowed to cool spontaneously at atmospheric pressure. The maximum size of ingot to which the application of Whitworth fluid compression is effective is an open question. The Harmet process of bottom pressure seems very successful in preventing segregation. The waste is much less than with the Whitworth process, although the skin is hardly so clean as that of the Whitworth ingot. Unfortunately, the view expressed to the author by an experienced and competent expert is that a relatively small—say, a 20-ton—ingot must be regarded as the limit to which bottom fluid compression by the Harmet method can be effectively applied.

In the author's view, in the heat treatment of forgings, anything like a protracted cooling, especially at a low red heat, is dangerous, and likely to lower unduly the elastic limit of the steel under treatment. Three other methods suggest themselves: 1. When the forging operation is over, let the forging cool in air, as far as possible out of draughts, and apply no further heat treatment. 2. Re-heat the forging to about 900° C., quench in oil, and finally let down by re-heating to a temperature between 300° and 400° C. 3. Recrystallise the steel and remove stresses from the forging by heating to about 900° C., or, at any rate, above Osmond's top critical change-point A_{c3} , and then cool as quickly as the circumstances of the case will permit, in air; in other words, normalise the material. In the opinion of the author, method No. 3 is likely to give the best average results.

Compression of Steel Ingots.—The production of sound steel continues to be one of the most important questions of the present time, and the various methods of dealing with the steel after it is poured into the moulds are reviewed by N. Lilienberg.* Reference is made to the use of aluminium, casting continuous ingots, keeping the top uniformly hot, casting with the large end upwards, and centrifugal machines. Reasons are given why these methods cannot come into general use for the largest quantities of heavy ingots, especially those which are cast standing on trucks. The only way to treat these is by compression of the semi-liquid steel. The principal methods of effecting this are compression from the top, compression from the bottom, compression from the sides in the moulds, and compression from the side on the bare ingots stripped of the moulds. From the details given, it appears that there is no method for making solid ingots which is suitable for the largest quantities of medium size, especially for those cast on trucks. At the same time, the desire remains as great as ever to lessen the waste and crop ends to obtain the proper structure of the steel with less rolling and forging than at present, and also to lessen the segregation. The question then arises: Is it possible

* *Journal of the Franklin Institute*, vol. clxv. pp. 121-140; *Jernkontorets Annaler*, vol. lxi, p. 572.

to accomplish this in a practical and sufficiently economical way? The requirements are as follows: 1. The casting should be made without changing the ordinary solid tapered moulds but the ingots stripped earlier than usual, which can be done. 2. The stripped ingots should not be removed from their places on the bottom until the compression is finished. 3. In order that the pressure may be continued according to the solidification, all the ingots will have to be pressed simultaneously, but they must be finished at different periods, according to the difference in heat between the preceding and following ingots. 4. This should arrange itself automatically without any special attendance, and the work of hauling, &c., should be reduced to a minimum. 5. The installation should be sufficiently simple, and not occupy too large a space in a steelworks. To all appearance there is only one way to accomplish this, namely, leaving the early stripped ingots standing inside of a framework, pressing the whole row of them simultaneously by a wall moved forward by driving in wedge blocks. Full details of the method are given.

Workshop Treatment of Steel.—Walter Rosenhain * discusses the workshop treatment of steel. While it is essential that steel should be capable of being worked into structures or machines without injury, it is equally desirable that the workshop manipulations should be so regulated as to effect a minimum of injury upon the material. The injurious effects of punching and shearing and other operations, which involve severe local deformation of metal, are fully dealt with. The author considers that there is a natural tendency to ascribe failures of steel to faulty material, but whilst the possibility of faulty material cannot be entirely precluded, careful inquiry into the workshop treatment to which the material had been subjected would often reveal the true cause of failure.

Steel Castings.—The manufacture of steel castings in Germany is described by G. Drakenberg. †

High-speed Steel.—Recent progress in the manufacture of high-speed steels is reviewed by G. Gherardi. ‡

Steelworks Equipment.—A new electric turret-type furnace charging and drawing machine constructed by the Alliance Machine Company, Alliance, Ohio, is described and illustrated.§ The machine has a record of charging 60 cold billets and drawing 60 hot billets and delivering them to the finishing-mill tables 75 feet away in 45 minutes. The boom is arranged with a tilting motion, but the operator's platform is stationary in this respect. The tongs are of the double-grip type, and open from 12 to 30 inches—a range wide

* *Times Engineering Supplement*, January 29, 1908, p. 3.

† *Bihang till Jernkontorets Annaler*, 1907, pp. 487-508.

‡ *Rassegna Mineraria*, vol. xxv. pp. 321-324; vol. xxvi. pp. 5-8, 39-41, 57-59, 74-75.

§ *Iron Trade Review*, vol. xli. p. 1006.

enough for the average variations of work to be handled. The machine has five motions, each of which is driven by an independent reversible motor. These are the bridge travel, the trolley travel, the revolving of the boom, and the gripping and releasing of the tongs. The machine has a rated capacity of 4 tons, but it can be made in any size and to suit any particular location or work.

An illustrated description has appeared * of a new form of electric lifting magnet made by the Cleveland Armature Company, Cleveland, Ohio. Two types of the machine are made—the interpole bell, and the interpole flat magnet—according as the machines are required to lift loose material, such as scrap, turnings, &c., or flat-surfaced pieces, ingots, bars, &c. A zinc tank weighing 9600 pounds can be handled by one of these machines, with a diameter of 52 inches.

Iron Alloys used in the Steel Industry.—W. Venator† has contributed a valuable paper on this subject, which focusses much of the most recent advances made in the manufacture and use of these alloys. He deals succinctly with each of the following materials: (1) Spiegeleisen and ferro-manganese; (2) ferro-silicon; (3) ferro-manganese-silicon, silico-spiegel; (4) aluminium and ferro-aluminium; (5) ferro-chrome; (6) nickel, ferro-nickel, ferro-nickel-chrome; (7) ferro-tungsten and metallic-tungsten; (8) ferro-molybdenum; (9) ferro-vanadium; (10) ferro-titanium; (11) ferro-phosphorus; (12) carborundum. Each of the above products is discussed in the order given, and typical analyses furnished of the actual products to be obtained in commerce, and also in most cases approximate prices at which the products and raw materials are obtainable.

1. *Ferro-manganese and Spiegel.*—The information given is well up to date, and historical details of the early attempts are given. It is of interest to note that efforts have been made in Russia to establish a ferro-manganese industry, so as to export the finished material in place of the ore, and in the list of continental works making ferro-manganese the following Russian works are named: Donetz-Jurieffka Works, Hughes Works, Russian Belgian Co., and the Dnieprovienne Co.

2. *Ferro-silicon.*—As made in the blast-furnace the maximum percentage of silicon is about 20 per cent., but the commercial grades usually contain from 10 to 14 per cent. The presence of aluminium in the slag facilitates the formation of ferro-silicon. Most of this low-grade ferro-silicon used on the Continent is obtained from Great Britain. Ferro-silicons containing over 20 per cent. of silicon are made in the electric furnace exclusively. Details of charges and cost of manufacture are given. Alloys up to 80 to 90 per cent. of silicon are made. According to Keller, the output of the Livet furnaces is at the rate of 16,000 tons per annum, and Hutton stated in 1907 that the Girod Works (Savoy) produce 5000 tons of 50 per cent., and 1000 tons of 30 per cent. ferro-silicon per annum.

* *Iron Trades Review*, vol. xli. pp. 596-597.

† *Stahl und Eisen*, vol. xxviii. pp. 41-49, 82-86, 149-156, 265-262.

3. *Ferro-manganese-silicon Alloys.*—These alloys are somewhat difficult to make rich in silicon in the blast-furnace, but high-grade silico-spiegel is now made in the electric furnace. It is probable that the siliceous manganese ores, which have hitherto been considered useless, will be employed to produce this material in the electric furnace. The low carbon contents render this material superior to ordinary ferro-manganese, and the author considers that insufficient attention has been paid to it. Analyses of three qualities are given:—

	Manganese.	Silicon.	Phosphorus.	Carbon.	Sulphur.
	Per Cent.	Per Cent.	Per Cent.	Per Cent.	Per Cent.
No. 1. . . .	50-55	20-25	0·06	1·0	0·03
No. 2. . . .	68-75	20-25	0·052	0·8	0·02
No. 3. . . .	50-50	30-35	0·04	0·65	0·02

4. *Aluminium and Ferro-aluminium.*—Details of the production per annum of each of the chief countries is given. The make of the five large companies in whose hands the manufacture of aluminium is practically confined amounted in 1906 to 19,000 tons.

5. *Ferro-chrome.*—This alloy is chiefly of importance in connection with the production of special steels. It has been made in the blast-furnace with up to 60 per cent. of chromium, and with about 12 per cent. of carbon. Its production requires a very large amount of fuel in the furnace, about 3 tons per ton of product being necessary. The world's production of chrome-iron ore is estimated at about 80,000 tons. Analyses of the chief deposits are given in the paper. Most of the ferro-chromium is now made in the electric furnace. Details and analyses of various makes are given. The estimated total make of ferro-chromium is about 5000 tons per annum, of which 1800 tons are produced in the United States.

6. *Nickel, Ferro-nickel, and Ferro-nickel-chrome.*—The high price of nickel has restricted its application to steel-making, in which it is well known to have a very favourable influence. A list of the companies in whose hands the world's supply of nickel practically is, is given, and analyses and costs of the ore. Analyses of the ferro-nickel and ferro-nickel-chrome met with in commerce are given. Two analyses of ferro-nickel-chrome given are:—

	1. Per Cent.	2. Per Cent.
Chromium	51-52	50-51
Nickel	17-19	17-19
Iron	28-30	28-29
Carbon	0·25-0·75	1·30-1·80
Various elements	0·10-0·20	0·10-0·20

7. *Ferro-tungsten and metallic Tungsten.*—Owing to the increasing use of high-speed steel, which owes its chief properties to this

element, tungsten ores are now greatly in demand, and the price has risen rapidly. The two chief ores are wolfram (FeWO_4) and scheelite (CaWO_4). The annual output of 60–70 per cent. ore is about 3000 tons, of which in 1906 England produced 251 tons. The metal is used in the tool steel industry, in the shape of metallic-tungsten and ferro-tungsten, the former being made by the reduction, by means of carbon and heat, of the chemically prepared oxide, the latter by electric reduction. Typical analyses of English metallic tungsten are given as follows:—

W.	Si.	C.	Al.	Fe.	Mg.	Mn.	O.
97.2	0.72	0.32	0.47	0.61	0.32	0.16	0.33
98.68	0.32	0.12	0.21	0.59	0.13

Typical analyses of ferro-tungsten are given as under:—

	Per Cent.	Per Cent.
Iron	43.20	13.50
Tungsten	51.74	85.79
Carbon	2.87	0.60
Silicon	0.85	0.06
Aluminium	0.94	...
Manganese	0.47	...
Sulphur	0.098	0.03
Phosphorus	0.051	0.003

8. *Ferro-molybdenum*.—Steel alloys of this metal are receiving considerable experimental attention. The raw materials are molybdenum glance (MoS_2) and wolframite (PbMoO_4), both comparatively rare minerals. Attempts have been made to use molybdenum in steel-making since about 1898. It has properties similar to tungsten, but it is said to require only one-third as much to give the same qualities. Both metallic-molybdenum and ferro-molybdenum are in use. Typical analyses of both materials are given. The melting-point of ferro-molybdenum is given at 1190°C . The Girod Works turn out about 50 tons of ferro-molybdenum per year.

9. *Ferro-vanadium*.—According to the author, the influence of vanadium on steel has not yet been sufficiently investigated and explained. The statement has been made that even 0.2 to 0.5 per cent. of this element very greatly increases the elongation and breaking strain of steel, and the author points out that Guillet is of opinion that, next to carbon, vanadium imparts the greatest improvement to the properties of iron. Analyses of the ferro-vanadium on the market are given.

10. *Ferro-titanium*.—In France, it is stated, the production of high-grade ferro-titanium is an accomplished fact, and analyses are quoted showing 52 per cent. of titanium.

11. *Ferro-phosphorus and phosphor-manganese*.—These materials are usually made in the blast-furnace, although latterly they have been made also in the electric furnace. Analyses of blast-furnace ferro-phosphorus are quoted, showing from 15 to 25 per cent. of phosphorus, with carbon usually under 1 per cent. Phosphor-manganese made in the blast-furnace contains: Silicon, 1 per cent.; manganese, 65 per

cent. ; phosphorus, 25 per cent. ; iron, 7 per cent. ; and carbon, 2 per cent.

12. *Carborundum (silicon-carbide)*.—Although chiefly made for grinding purposes, this material is also used to some extent in steel manufacture. Analyses of carborundum, which consists chiefly of silicon-carbide, are given :—

	1.	2.
	Per Cent.	Per Cent.
Silicon	69·19	62·0
Carbon	29·71	35·0
Iron and alumina oxides	0·39	Al. 1·5
Lime and magnesia	0·25	Fe. 1·5

Various other alloys are mentioned, which possess only a scientific interest. Amongst these is ferro-boron, of which the following analysis is given :—

	Per Cent.
Carbon	2·855
Boron	32·10
Sulphur	0·03
Phosphorus	0·005

In the United States ferro-sodium containing 25 per cent. of sodium is said to have been recently produced. The paper concludes with an account of the products obtained by the aluminothermic process. A full English translation of this paper has appeared.*

E. F. Lake † gives a general review of the improvements made in metals used in the building of all kinds of machinery, and of some of the new metals and alloys that have been brought into use.

Steel Rails.—The manufacture of Bessemer steel rails is discussed by F. E. Abbott. ‡

S. T. Fiero § discusses the past and present mechanical treatment of steel rails. He considers that the cause of the present day troubles with rails is due to the decrease of the number of roll passes. As a proof that rails are much stiffer and of finer granular structure under a greater number of passes, results of drop tests of rails made with twenty-three passes as against the same section with twenty-two passes, are given.

H. E. D. Walker || describes an ingenious apparatus for obtaining exact sections of worn rails to the actual size.

Sleepers.—In connection with the rusting of steel rails, reference is made to a report by J. W. Post, ¶ chief engineer of the Netherlands State Railways, relating to iron sleepers that had been bedded in

* *Iron and Coal Trades Review*, vol. lxxvi. pp. 520–522, 729, 816–817, 1010–1012.

† *American Machinist*, vol. xxx. Part II., pp. 709–711.

‡ Paper read before the Central Railway Club, Buffalo, New York, November 8, 1907 ; *Mechanical Engineer*, vol. xxi. pp. 86–88.

§ *Industrial World*, vol. xli. pp. 1376–1379.

¶ *Minutes of Proceedings of the Institution of Civil Engineers*, vol. clxx. pp. 308–314.

¶ *Machinery*, vol. xiv. p. 156.

gravel and sand ballast for thirty-five years. The original weight of the sleepers was 125 lbs. They decreased in weight from rust and wear, on an average, one-quarter of a pound in every year, making a total decrease in weight in thirty-five years of 8·75 lbs.

Details of a new press for the manufacture of sleepers, patented by the Hoesch Co. of Dortmund, are described and illustrated.* The machine is capable of a very large output, from 14 to 15 sleepers per minute being pressed. In practice about 7500 sleepers can be made in the single shift.

A long historical and technical history of steel sleepers has been published by A. Haarmann.† The paper is accompanied by forty-five woodcuts showing the various forms of sleepers in use from the earliest dates, the first showing the cast-iron rails on stone sleepers in use at Merthyr Tydfil in 1804. Details are given of the mileage of various sleepers in use at different dates. The comparative cost of iron sleepers as compared with wooden ones is fully dealt with.

A full English translation of A. Haarmann's paper has been published.‡

The behaviour of steel sleepers on German railways is discussed by A. Haarmann.§

Steel for Motor-Cars.—Joseph Schaeffers|| deals with various alloy steels employed in the construction of motor-cars. Bessemer steel is unsuitable. Alloy steel is preferable, even if the price is four times that of Bessemer steel, because it possesses a greater limit of elongation. When inferior material is employed the motor-car is too heavy and the life of the tires is short. The author considers that exceptionally small differences in the chemical composition influence the quality of the steel to a considerable degree. From this point of view he deals with the influence of elements mixed with the steel on the quality of the metal, and describes several compositions, the results of tests of these steels submitted to static and dynamic stresses, and their possibilities of application and treatment. Special reference is made to the vanadium-steel manufactured by the American Vanadium Company, Pittsburg. The author determines the limits of harmful elements and of those which have a beneficial influence. It is found that the power of resistance of steel to continued vibrations, if the materials are of good quality, has the following values: Machine steel, 0·3 per cent. of carbon, resists 400,000 vibrations; nickel-chromium steel resists 6,000,000 vibrations; vanadium-nickel-chromium steel resists 15,000,000 vibrations.

L. Révillon¶ deals with special steels from the point of view of the manufacture of motor-car parts, and shows that the present tendency

* *Stahl und Eisen*, vol. xxviii. pp. 159-161.

† *Ibid.*, pp. 177-197.

‡ *Engineer*, vol. cv. pp. 189-191.

§ *Organ für die Fortschritte des Eisenbahnwesens*, 1907, p. 190.

|| *Der Motorwagen*, 1907, No. 33.

¶ *Revue de Métallurgie*, vol. v. pp. 53-68.

is constantly in the direction of requiring greater resistance and hardness without duly regarding the increased brittleness thereby resulting. Thus, despite the theoretical investigations which have revealed the fact that steels, the structure of which tends to become martensitic, are dangerous, attempts are constantly made to approach this quality of steel, and steels are freely dealt in which the microscope shows to be on the boundary line, which a slight variation in composition or an error in heat treatment would render dangerous. He classifies the various categories of steels commonly required as follows: (1) Case-hardening steels; (2) steels employed in motor construction either in the raw state or after annealing; (3) steels employed after quenching whether tempered or not; (4) spring steels; (5) steels for bearings; (6) magnet steels. For steels of the first category special steel has almost entirely superseded the use of ordinary steel. Steel containing about 2 per cent. of nickel was first employed, its easy case-hardening qualities and its great safety compensating for certain difficulties in the way of working it and disadvantages in the way of cost, but, having been found too soft, it has been replaced by a nickel steel containing about 1 per cent. of chromium. Case-hardening steels of chromium alloys alone do not exhibit the extraordinary brittleness encountered in nickel steels, but still retain the property of becoming exceedingly hard beneath the case-hardened and annealed layer.

Steels of the second category do not necessitate extreme hardness. They are used for the body and chassis of cars, and may contain 3 per cent. of nickel and 0.25 per cent. of carbon, although special parts such as connecting rods may be made one-third stronger, and proportionally lighter with steel containing 5 to 6 per cent. of nickel. The manufacture of valves from steel containing 36 per cent. of nickel has been abandoned since it has been ascertained that an equally untarnishable steel can be obtained from a mild quality containing but 5 per cent. of nickel, except in the case of valves for very hot and moist gases in motors.

Steels of the third category are chiefly used for gears and for shafting. The types used are described, and the proportions of nickel, chromium, and carbon usually adopted, are noted. Vanadium exerts an improving influence on quality despite the small percentages of the element employed. Generally speaking the nickel chromium steels suffice for most purposes, and nickel-chromium-vanadium alloys are only required in exceptional cases. These steels are subject, however, to two grave disadvantages; their deformation on quenching, and their requiring annealing to remove the brittleness which supervenes on first quenching. A special steel containing small percentages of manganese, nickel, and silicon which obviates these disadvantages is described.

The remaining categories of steel are discussed briefly, and the advantages of the electric furnace, and of the Girod process in particular, for the manufacture of special steel are noted.

Steel for Structural Purposes:—J. A. L. Waddell * gives the results of twelve tests of steel columns made to determine the relative strengths of carbon steel and nickel steel. The nickel steel columns gave an elastic limit of 41,200 to 52,800 lbs. per square inch, and the carbon steel, 21,300 to 28,800 lbs. per square inch.

Reports by G. K. Gilbert,† R. L. Humphrey, J. S. Sewell, and F. Soulé on the San Francisco earthquake and fire of April 18, 1906, and their effects on structures and structural materials contain much information of the effects on steel buildings.

In a review of engineering in the United States in 1907,‡ reference is made to the spectacular feature of building as an engineering work in the construction of the numerous steel-frame office buildings of enormous height in New York. The highest of these is the tower of the Manhattan Building, 75 feet by 85 feet, 660 feet high to the top of the cupola. This has forty-eight stories. Next to this is the tower of the Singer Building, forty-two stories, with a height of 612 feet. The main portions of these buildings are respectively eleven and fourteen stories high. On the other hand, the City Investing Company Building has the main building twenty-five stories high, with a tower 70 feet square, having thirty-two stories, and rising to a height of 400 feet above the street. In all these cases the towers are used as offices, &c., like the main parts of the building. This requires very elaborate lift equipment, with high speeds. The city now has one building each of forty-eight, forty-two, and thirty-two stories; twenty buildings of twenty to twenty-six stories; fifty of fifteen to twenty stories; and 465 buildings of ten to fifteen stories in height.

J. H. Hecks§ gives particulars of tests of steel plates removed from old boilers and ships, which afford little evidence of that loss of quality so prominent in the specimens tested by C. E. Stromeyer.|| Out of twenty-eight specimens cut from plates removed from old boilers, owing to damage or corrosion, only five showed an elongation of less than 20 per cent. in 8 inches, the tenacity in no case being less than 25½ tons per square inch. These five specimens had suffered much from corrosion or wasting. The remainder of the specimens showed very fair results, the tenacity averaging 27 to 28 tons per square inch, with elongations running from 20 to 27 per cent. in 8 inches. Out of the whole twenty-eight but two failed to bend double without cracking, though some of the specimens were twenty-five years old. A similar investigation made with ship-plates, removed mainly owing to damage by collision or stranding, also gave satisfactory results, though one-quarter failed to stand without cracking a cold bend through 180°.

The use of steel in the construction of large water-service tanks at

* *Engineering News*, vol. lix. pp. 60-63.

† *United States Geological Survey, Bulletin No. 324.*

‡ *Engineer*, vol. cv. pp. 51-52.

§ *Transactions of the North-East Coast Engineers and Shipbuilders* (advance proof).

|| *Journal of the Iron and Steel Institute*, vol. lxxv. pp. 86-107.

Sydney is described by C. W. Smith.* Tensile tests of the steel used are given.

Reinforced Concrete.—In a paper read before the Society of Arts, Ernest R. Matthews,† after stating that reinforced concrete had been more extensively used in the United States of America than in any other country, went on to describe various works that had actually been completed in this material. As is well known, reinforced concrete has been adopted by American engineers and architects with much greater alacrity than has been the case in Great Britain, the cause being, perhaps, partly due to the conservative and unyielding laws. There are, however, signs that the future will, at no very distant date, bring a marked change in the more extended adoption of reinforced concrete to the many purposes for which it is so well adapted. The works described included reservoirs, aqueducts, conduits, water-mains, dams, sewage works, bridges, railway sleepers, tunnels, wharfs, jetties, foundations, columns, walls, roofs, floors, and chimneys, and in the descriptions of many of the works were given particulars as to the quantity of material used, the time occupied in the construction, and, in some cases, the cost. The paper also included an appendix giving the regulations of the city of Chicago in respect of the use of reinforced concrete construction.

Examples of construction in ferro-concrete are given by J. S. E. de Vesian,‡ and some new uses for reinforced concrete are described by W. Noble Twelvetrees.§

M. Kahn|| discusses the practical application of reinforced concrete. He expresses the opinion that reinforced concrete is the best form of construction when properly handled, and the worst when improperly handled. Such being the case, it behoves the owner and the architect to insure that only the best class of contractor is employed on his work. Contractors can only afford to carry out work which will ensure them a fair amount of profit, and if, by the adoption of reinforced concrete, the owner is saved 10 per cent. of the cost of construction, it is advisable to grant the contractor any extra saving, so as to ensure his giving a construction which will prove satisfactory in every respect. When owners and engineers realise this point, and act accordingly, reinforced concrete will reach that position in the category of structural materials to which it justly belongs.

J. S. E. De Vesian¶ deals with the application of reinforced concrete to engineering construction, and points out the importance of using steel of suitable quantity for its intended purpose in reinforced

* *Minutes of Proceedings of the Institution of Civil Engineers*, vol. clxx. pp. 365-376.

† *Journal of the Royal Society of Arts*, vol. lvi. pp. 429-447.

‡ *Report of the Seventy-seventh Meeting of the British Association*, London, 1908, p. 623.

§ *Ibid.*, p. 624.

|| *Transactions of the Institution of Engineers and Shipbuilders in Scotland*, February 18, 1908.

¶ Paper read before the Civil and Mechanical Engineers' Society, November 6, 1907; *Times Engineering Supplement*, November 13, 1907, p. 6.

concrete work. Mild steel produced by the basic open-hearth process, with a tensile strength of from 28 tons per square inch to 32 tons per square inch, and an elongation of 20 per cent. in a length of 8 inches, is the best for general employment. High carbon steel is unsuitable, as is also any metal of variable quality. The quality of the Portland cement used is of the greatest importance, and the author states his preference for cement of the finest grinding, giving not more than a 20 per cent. residue on a 180 by 180 mesh sieve. The permissible expansion specified by him, under the Le Chatelier process, is only half that allowed by the British standard specification. The sand to be used and the proper mixing of the cement are also dealt with.

H. C. Turner* gives an example of the preservation of steel embedded in concrete. Steel bars erected in 1902 were perfectly preserved, even in cases where the concrete protection was only three-quarters of an inch thick.

E. Probst† has published an exhaustive report on the influence of the reinforcement and of cracks in the concrete as its strength.

M. Foerster‡ has given an interesting description of the various systems of reinforced concrete, and also deals with the theory of its use. Sketches are given of the sections employed for various purposes, together with data as to the strength of the sections.

P. Rohland§ has considered the reason of the non-oxidation of iron embedded in reinforced concrete from a theoretical standpoint.

Armour-plates and Projectiles.—J. W. Warr|| describes the manufacture of armour-plates, and comments on the application made of electricity for power.

Improvements in the manufacture of armour-plates are reviewed by M. Kralupper¶

The development of the manufacture of armour-plates formed the subject of a lecture delivered in Rome by Ugo Gregoretti.**

The Pozzuoli Ordnance Works, near Naples, are described by J. B. Van Brussell.††

The exhaustive paper read by T. J. Tresidder before the Institution of Naval Architects is practically a thesis on the use and action of caps.

C. N. Robinson †† gives details of recent progress in armour and ordnance, with information as to the resources of the manufacturing countries. Detailed reference is made to the employment of

* *Engineering News*, vol. lix. p. 76.

† *Mitteilungen aus dem Königlichen Materialprüfungsamt; Ergänzungsheft I.* p. 144. with 77 illustrations and 9 plates.

‡ *Stahl und Eisen*, vol. xxvii. pp. 1757-1764.

§ *Ibid.*, vol. xxviii. pp. 156-158.

|| *Electrical Review*, vol. lxi. pp. 1071-1074.

¶ *Oesterröichische Zeitschrift für Berg- und Hüttenwesen*, vol. lv. pp. 617-622.

** *L'Industria* (Milan), vol. xxi. pp. 712-714.

†† *American Machinist*, vol. xxx. pp. 913-915.

‡‡ *The Naval Annual*, 1908. Edited by T. A. Brassey. Portsmouth.

Hadfield's "Era" steel, which enables hoods for quick-firing guns to be cast into shape without forfeiting any part of the toughness of forged steel. Some results are given of the latest armour manufactured by William Beardmore & Co., Limited, and of results of projectile trials. An important question is raised in reference to supply of raw material. It is pointed out that nearly all the material used in armour in Great Britain is imported, which raises anew the question as to whether it would not be worth the while of the Government to make arrangements with certain firms to have bonded stocks of the raw material necessary for the manufacture of the highest quality of war equipment, as otherwise, in case of foreign complication, there might be serious difficulty met with in production.

Armour-plate Vault.—An illustrated description has appeared * of an armour-plate vault constructed by the Bethlehem Steel Company, South Bethlehem, Pennsylvania, for the Carnegie Safe Deposit Company, New York. The vault is built of 1215 tons of 4-inch armour-plate, containing 3.25 per cent. of nickel, the heaviest ingot used in making the plates having been 193,000 lbs. in weight, and being made up of the combined heats of three open-hearth furnaces. The subsequent plate only weighed 58,000 lbs. The main doors weigh 40,000 lbs. each.

Ordnance.—Gustave Canet, honorary member of the Iron and Steel Institute, has honoured the Junior Institution of Engineers by accepting the presidency, and in his inaugural address, which was delivered on November 18, he frankly and critically compared English and French practice in connection with the design and manufacture of artillery. The conditions under which gunmakers work in the two countries are, he pointed out, essentially different. The whole tendency of French policy has been adverse to the interests of private manufacturers. In Great Britain, on the other hand, there has never been any restriction placed upon manufacturers with regard to the supply, during peace time, of war material to foreign Powers. Hence works of private manufacturers have developed and have acquired vast experience that is a valuable national asset, for they can place all their resources at the disposal of the Government in case of need.

The manufacture of big guns in Sweden at the works of the Bofors-Gullspång Company, visited by the Iron and Steel Institute in 1898, is described.† Illustrations are given of an 8.27 capped A.P. shot after perforating a 10-inch K.C. plate, the breech end of the new 5.9-inch gun, a 6-inch A.P. capped shot and a 7-inch K.C. plate perforated by it, the new 5.9-inch gun on naval mounting, the breech mechanism for the 9.45-inch gun, with plates of views of the works and of various types of gun manufactured.

* *Iron Age*, vol. lxxx. pp. 1214-1217; *Machinery*, vol. xiv. pp. 131-134.

† *Engineer*, vol. cv. pp. 446-448.

In the new gun factory at the Parkhead works of William Beardmore & Company, Limited,* preparations have been entered upon for the construction of the first 12-inch naval gun that has ever been made in Scotland. The weapon is to be built for the British Admiralty. The 12-inch wire-wound gun fires a projectile weighing 850 lbs. The value of such a weapon is set down at about £22,500.

Tinning.—An important blue-book, compiled by Miss A. M. Anderson and T. M. Legge, has been issued on dangerous and injurious processes in the coating of metal with lead, or a mixture of lead and tin. The report also contains the results of an experimental investigation into the conditions of operating tinning workshops, which has been written by G. E. Duckering, one of His Majesty's inspectors of factories, who carried out the investigation. The most important of the suggested regulations set forth in the report is that no lead should be used in the tinning of metal hollow-ware.

Electrolytic Pickling of Steel.—C. J. Reed † proposes to remove the scale on steel by making the metal the cathode in a sulphuric acid bath.

Duplex Metal.—B. E. Eldred ‡ describes the method devised by J. F. Monnot for the production of steel wire coated with copper.

Needles.—E. P. Buffet § traces the history of the manufacture of needles.

The origin of the establishment of the needle industry in Redditch, which town is now famous for its needle production, is uncertain, but recent researches seem to show that the art of needle-making was probably first taught to the inhabitants by the monks of the Cistercian Abbey of Bordesley, which was a large religious house existing on the outskirts of the present town of Redditch, and was dissolved in 1538. The growth of the trade, however, must have been very slow, and it was not until toward the end of the eighteenth century that the bulk of the English needle-making industry was concentrated in and about Redditch.||

Spanish Ironwork.—For twenty-five years there remained on loan at the Archæological Museum at Madrid a magnificent display of Spanish ironwork. Owing to the death of the owner, the collection of five thousand specimens was brought to London for sale in December 1907. The majority of the specimens belong to the fifteenth

* *Engineer*, vol. cv. p. 453.

† *Transactions of the American Electrochemical Society*, vol. xi. pp. 181-184.

‡ *Engineering News*, vol. lviii. pp. 521-522; *American Machinist*, vol. xxx. pp. 474-475.

§ *American Machinist*, vol. xxx. pp. 740-742.

|| *Engineer*, vol. cv. p. 219.

and sixteenth century. Aymer Vallance* considers that the most characteristic decorations are the nail-head bosses with which wooden doors were ornamented. But whether in nail-heads, hinges, locks, door-knockers, grilles, or processional crosses, the suitability of purpose and the capacity and limitation of the metal are never misunderstood.

* *Burlington Magazine*, vol. xii. p. 163.

PHYSICAL PROPERTIES.

Specific Heat of Iron.—P. Oberhoffer * gives the results of investigations on the specific heat of iron, describing the apparatus made use of for such determinations. He deals with the great difficulties encountered in the exact determination of the specific heat of iron. The high point of fusion and the affinity of iron for oxygen at high temperatures render the determination difficult. The results of former known observers extend from -192° to $+1158^{\circ}$. Most observers employed the method of mixtures. Exact data concerning the chemical composition of the material tested are generally not available, and the data given by former observers often indicate considerable variations. Pionchon was the first to attempt to solve in a complete manner the problem of the specific heat, and at the same time was the first to draw attention to the relation which exists between the calorimetric examination and the allotropic transformations originating in iron by the introduction of heat. After Pionchon, Harker and Stücker have contributed extensive researches to this problem. The works of these and former workers are collected in a table. The author briefly describes the work of Pionchon, Harker, and Stücker, and then deals with his own experiments. 1. Preliminary experiments, which comprise the methods employed up to the present time to determine the specific heat: (a) Preliminary experiments with the water calorimeter (method of mixtures); (b) preliminary experiments with the Bunsen ice calorimeter. 2. Preliminary experiments in order to develop the author's method. Preliminary experiments with the Berthelot water calorimeter soon showed that this method was unsuitable owing to the formation of aqueous vapour. Preliminary experiments with the Bunsen ice calorimeter showed that only the ice calorimeter could be employed, because only this allowed direct evacuation. A complete description of the calorimeter employed by the author is given, of the important alterations made by him, of the arrangement of insulation of the calorimeter proper, of the Heraeus furnace employed, and of the methods of experimenting arranged by the author. The chemical composition of the material employed by the author was:—

* *Stahl und Eisen*, vol. xxvii, pp. 1764-1767; *Metallurgie*, vol. iv, pp. 427-443, 447-455, 486-497; *Zentralblatt für Eisenhüttenwesen*, vol. ii, p. 667-669.

	Per Cent.
Carbon	0·06
Silicon!	0·006
Phosphorus	0·005
Sulphur	0·019
Manganese	0·05

The results of the experiments are given in Tables I. and II.

TABLE I.

Temperature. Degrees C.	Weight of the Sample.	Corrected Hg. Weight.	Calories given up by 1 Gramme of Iron.
	Per Cent.	Per Cent.	Per Cent.
265	6·0889	2·9232	31·0
391	6·0889	4·7535	50·4
440	5·4352	4·9167	58·4
500	5·1923	5·4611	67·9
543	3·9733	4·6113	74·9
552	3·9733	4·7191	76·6
573	3·9733	4·9965	81·1
622	4·1006	5·6112	88·3
638	5·0792	7·2933	92·7
640	2·7374	3·9857	94·0
660	2·7374	4·1766	98·5
700	2·6943	4·6655	111·8
709	2·6943	4·7374	113·5
756	2·6943	5·3006	127·0
766	2·6943	5·4124	129·7
769	2·6943	5·4208	129·9
790	2·1964	4·5619	134·1
802	2·1964	4·6436	136·5
834	2·1964	4·8204	141·7
844	2·1964	4·8896	143·7
880	1·7577	4·0596	149·1
883	1·7577	4·0514	148·8
915	1·7577	4·3199	158·7
977	1·7577	4·4184	162·3
995	0·9984	2·5775	166·7
1011	1·7577	4·5878	168·5
1018	0·9984	2·5950	167·8
1040	2·0779	5·5001	170·9
1078	0·9984	2·7658	178·8
1123	0·9984	2·8969	187·3
1140	0·9984	2·8966	187·3
1163	1·7381	5·2417	194·7
1210	0·9984	3·1007	200·5
1305	0·9984	3·3559	217·0
1376	0·9984	3·5325	223·4
1420	0·9984	3·6542	236·3
1495	0·9984	3·8539	249·2
1523	0·9984	3·9315	254·2

The experiments show that each modification corresponds to a definite direction of the variation of temperature of the specific heat. The direction of the curve of the average specific heats in the vicinity of

Ar₂ permits with great probability the conclusion that the transformation of β into α iron is completed by a continuous series of mixed crystals. The average specific heat of γ iron is practically constant.

TABLE II.

Temperature. Degrees C.	Average Specific Heat.	Temperature. Degrees C.	Average Specific Heat.
	Per Cent.		Per Cent.
250	0·1221	900	0·1698
300	0·1257	950	0·1688
350	0·1286	1000	0·1678
400	0·1305	1050	0·1670
450	0·1340	1100	0·1664
500	0·1360	1150	0·1667
550	0·1395	1200	0·1667
600	0·1417	1250	0·1666
650	0·1463	1300	3·1662
700	0·1594	1350	0·1661
750	0·1675	1400	0·1665
800	0·1698	1450	3·1665
850	0·1699	1500	0·1667

Hardness of Steel.—A. F. Shore * gives an illustrated description of the scleroscope, an instrument designed for determining the relative and quantitative hardness of all metals, including hardened steel. The instrument consists of a ball or plunger, weighing only 40 grains, which slides loosely in a graduated glass tube. The ball is held at the top of the tube by a pin having a piston in a small cylinder, and a spring which serves to grip the hammer. The release of the ball is effected by means of a small rubber bulb. When hard steel is struck the actual concussion is equal to about 30 pounds constant pressure, while in softer metals the shock is more readily absorbed, the concussion in lead being hardly more than 1 or 2 pounds. The determination of the hardness of the test-pieces is measured by the rebound of the drop weight. In lead the rebound is but $1\frac{1}{2}$ per cent. of the fall, while in very hard steel it is 73 per cent. The author discusses the hardness of steel, and gives a scale of hardness for various metals.

E. Meyer † has made some experiments on the Brinell test for hardness, in order to determine what influence the pressure and diameter of the ball employed have on the hardness number. The theory of the compression method for determining the hardness is discussed.

A. Gessner ‡ describes the method of determining hardness with the Ludwik cone test.

* *American Machinist*, vol. xxx., Part II., pp. 747-751.

† *Physikalische Zeitschrift*, 1908, p. 66.

‡ *Zeitschrift des Oesterreichischen Ingenieur- und Architekten Vereins*, vol. lix. pp. 799-800.

Segregation in Steel Ingots.—H. M. Howe* contributes a further study of segregation in steel ingots, and gives a digest and analysis of the scattered information collected by other investigators, together with certain results he has obtained recently in his own researches. He propounds, in a series of questions, the chief problems which require elucidation, and deals chiefly with the first two, viz., the influence of the size of the ingot, and of the rate of cooling. Taking the latter first, it is noted that each layer of steel as it freezes splits into two sublayers—a more pure one which freezes, and a less pure one which remains molten. If the cooling is very slow the impurities in this molten sublayer have good opportunities for passing centreward by diffusion and connection, so that when the next layer comes to freeze, the enrichment which it has received from the freezing of the last preceding layer will be in large part effaced by this centreward movement. If, however, the freezing is very rapid, then, when the second layer comes to freeze, it will still retain most of the impurities expelled into it by the freezing of its predecessor. Slow freezing should therefore favour a centreward migration of impurities, while rapid freezing should tend to hamper this process by locking up the impurities in each successive layer frozen. It would also naturally be expected that slow cooling would imply slow freezing, and *vice versa*. An examination of the actual results obtained in practice follows, together with a discussion of the results of surfusion, the nature of which is explained, while the consequences arising from this condition are also enumerated in detail. The results of the investigations are summed up as follows:—

Between the limits of $2\frac{1}{4}$ inches square and 16 inches square the influence of the size of the ingot on the degree of segregation is of so slight a nature as to be almost masked by other variables, although in large ingots, *e.g.*, 30 inches or more across, there are indications which suggest that large size in ingots increases segregation. In most cases there is more segregation in ingots cooled quickly than in those cooled slowly, while the tendency of the latter should be to increase segregation. The paradox may be explained in part by the quietness to which both large ingot size and slow cooling lead. This quiet should restrain segregation by favouring the land-locking type of solidification by lessening convection currents and the evolution of gases, and by leading to surfusion.

The most enriched part lies in the axis of the ingot, usually at a distance from the top of between 6 and 28 per cent. of the ingot's length. The most impoverished part is probably rarely, if ever, axial. The enrichment in phosphorus and sulphur seems to be parallel with that in carbon, so that the isophoses and isotheis (lines of equal phosphorus and equal sulphur) are parallel to the isocarbs. On a general average of many cases the average maximum enrichment in phosphorus is about twice, and that in sulphur about three times, that in carbon, but in individual cases the ratios vary widely. Unusual

* *Engineering and Mining Journal*, vol. lxxxiv. pp. 1011–1015.

freedom from sulphur and phosphorus does not appear to restrain segregation of carbon, but, if anything, rather to increase it.

Influence of Gases on the Structure of Cast Iron and Steel.

—J. E. Fletcher * points out that gases play an important part in the structure of cast iron. Unless sufficiently large feeding heads and risers are provided near the heaviest sections of a casting, blow-holes, cavities, or "pipes" are inevitable, and the real object of a feeding head is to allow gases to escape and to give liquid iron the opportunity to replace the space recently occupied by the gases. The effects of gas on segregation in cast iron and in steel are discussed. It would not be surprising if the contraction or shrinkage of a metal were to be found to be almost entirely due to the driving off of the gases set free during solidification. Specific gravity and dilatation or expansion under heat are obviously associated with this question. The connection between specific gravity, weight, and volume of various sorts of iron is discussed, and the suggestion made that the non-expansibility and high specific gravity (8.05) of the non-expansible nickel-iron alloy (36 per cent. of nickel) are associated with freedom from gas inclusion. A series of diagrams and of photomicrographs illustrating the subject, and bearing on the ingot diagram published by Harmet, † are given.

Crystallisation of Steel.—Walter Rosenhain ‡ states that microscopic study has proved beyond doubt that all metals possess, in any state, a truly crystalline structure, and that, therefore, ordinary materials of construction, particularly iron and steel, cannot be said to possess the fibrous structure, as has so often been contended. The fact that metals are characteristically crystalline does not in any way conflict with the knowledge of their ductility and strength. When fibrous fractures appear it is because the crystals have been subjected to deformation before the fracture occurs, by the application of stresses in a certain manner, while on the other hand, when sudden and intensely local forces develop, the crystals will split along their natural cleavage before any amount of deformation has taken place. The crystalline or fibrous character of the fracture is, therefore, dependent not so much upon the character of the metal itself as upon the manner in which the fracture has been produced. The author concludes that inasmuch as metals, in their normal condition, already have a truly crystalline structure, it is evident that exposure to vibration cannot produce such a structure, although it might modify the character of the crystals already existing. There is no evidence at all that any change in the size or arrangement of the crystals of a metal can be produced either by vibration or fatigue.

In a presidential address delivered before the Birmingham University Metallurgical Society, T. Turner § described the principles of

* Paper read before the Staffordshire Iron and Steel Institute, November 23, 1907.

† *Journal of the Iron and Steel Institute*, 1902, No. II. p. 146.

‡ *Times Engineering Supplement*, November 6, 1907, p. 3.

§ *Ibid.*, December 11, 1907, p. 4.

crystallisation, and explained the difficulties of determining to which system any crystalline form belonged.

The Cohesion of Steel.—On May 18 a paper on “The Cohesion of Steel, and on the Relation between the Yield-Points in Tension and in Compression,” was read by G. H. Gulliver* before the Royal Society of Edinburgh. The author said that in a homogeneous, isotropic solid, the directions of maximum shearing stress are inclined at 45° to the directions of principal stress. If $\mu = \tan \phi$ be the coefficient of internal friction, the surfaces of sliding are inclined at $\alpha = (45^\circ + \phi/2)$ to the directions of principal tension, and at $\beta = (45^\circ - \phi/2)$ to the directions of principal compression. Experiments upon steel bars under simple tensile stress give $\alpha = 50^\circ$, $\phi = 10^\circ$, $\mu = 0.176$. This value of μ corresponds closely with the ordinary coefficient of friction for dry metallic surfaces. Assuming that the material yields under a tensile stress for the same limiting value of frictional resistance as when under a compressive stress, the ratio of the yield-point in tension to that in compression is calculated as 0.705 for steel, but from direct measurements the ratio appears to be higher.

The shearing stress along a surface of sliding is always greater than the frictional resistance due to the normal stress upon the same surface. The additional frictional resistance required to balance the shearing stress is assumed to be due to a cohesive force acting normally to the same surface, and the value of this cohesion for steel is calculated as equal to a stress 3.384 times that which corresponds with the tensile yield-point, or to 2.384 times the compression yield-point ($2.384/3.384 = 0.705$). A bar cannot break in tension until the stress is equal to the cohesion in some part of the specimen. The values of the cohesion for a number of bars are calculated from their yield-points, and these values are found to agree very closely with the actual stresses in the bars at rupture. The fracture of a bar under tensile stress should begin in a direction normal to the axis. Numerous experiments confirm this.

Structure of Malleable Iron.—E. Heyn † deals with the etching of malleable iron for the visual investigation of structure.

Microstructure of Iron and Steel.—In a lecture on the internal architecture of metals, J. O. Arnold ‡ gave examples of the microstructure of iron and steel.

F. Kerdyk § describes the failure of one of the propeller-shafts of the ss. *Goentoe*. The shaft was 13 inches in diameter. The microstructure in the immediate vicinity of the fracture showed coarse-

* *Engineering*, vol. lxxxv. p. 718.

† Report presented at the Brussels Congress of the International Association for Testing Materials; *American Machinist*, vol. xxx., Part I., pp. 806-807.

‡ *Ironmonger*, vol. cxxii. p. 249.

§ *Dinglers Polytechnisches Journal*, vol. cccxxii. pp. 683-685.

grained ferrite, surrounded by pearlite. One foot from the fracture the structure was normal. The material contained from 0·31 to 0·35 per cent. of carbon. The structure clearly showed that the shaft had been over-heated considerably at the position of the fracture. From the tensile test the defective nature of the material was not apparent: Tensile strength, 68,268 pounds per square inch; elongation, 30 per cent.; contraction, 59·3 per cent. In order to prove with certainty that the accident was due to defective heat treatment of the shaft, alternate bending tests by the Wöhler method, with short cylindrical test bars sharply turned in the middle to $\frac{3}{8}$ inch diameter, were arranged. One end of the test-pieces was screwed into the end of a $1\frac{1}{4}$ inch horizontal shaft supported by two bearings, and the free end of the test-pieces was supported by a bearing loaded in such a manner that the bending tension at the smallest section was 28,450 pounds per square inch. The shaft made 450 revolutions per minute, the number of revolutions until fracture was determined. It amounted to: (1) For a normal shaft with 0·4 per cent. of carbon, 54,000; (2) for the shaft of the *Goentoe* (*a*) in the original condition, 24,750; (*b*) after annealing during one hour at 800°, 4500 reversals of stress. The experiments prove that the fracture was caused by defective heat treatment.

Metallography.—The practical value of metallography is discussed by F. Giolitti* with special reference to experience at the Bethlehem works, United States. His paper forms a continuation to a series of articles to which reference has previously been made.†

K. W. Zimmerscheid‡ describes an inexpensive machine for polishing metal sections.

R. Baumann§ describes the application of metallography as a method of testing.

J. Grone|| discusses the mechanical properties and microscopic structure of iron and steel, and shows how they are influenced by thermal treatment.

Notes on metallography are given by O. Wawrziniok.¶

P. Goerens** describes the application of colour-photography in metallography. Examples of coloured photographs of etched sections of iron and steel had previously been exhibited by E. F. Law at a meeting of the Royal Microscopical Society on November 20, 1907.

L. Guillet†† emphasises the importance of having a datum basis for observations in metallography, and describes a method devised by L. Grix, and employed in the laboratories of the Dion-Bouton works,

* *Rassegna Mineraria*, vol. xxvii. pp. 257-259.

† *Journal of the Iron and Steel Institute*, 1907, No. III. p. 491.

‡ *Journal of the American Chemical Society*, vol. xxix. pp. 855-858.

§ *Zeitschrift des Vereines deutscher Ingenieure*, vol. lvii. p. 149.

|| *Gorni Journal*, 1907, pp. 1-21.

¶ *Zeitschrift des Vereines deutscher Ingenieure*, vol. li. pp. 1754-1757.

** *Metallurgie*, vol. v. pp. 19-23.

†† *Revue de Metallurgie*, vol. iv. pp. 1027-1036.

by which the exact position and occurrence of constituents may readily be located. The method, which is very simple and involves the use of no new appliances, enables many useful operations to be carried out, such as repeated etching in specific areas, and the identification of special constituents in photographs, and in the teaching of metallography. It consists of a couple of points, at right angles to each other, on the stage of the microscope, the sample being scratched by a file so that one of its sides shall correspond with the direction of one of the impinging points. A series of photomicrographs are given bringing out a number of interesting details resulting from the successive treatment of the same sample by different reagents, the effect being accurately localised by the method described.

E. Heyn * and O. Bauer discuss several points in the metallography of pig iron. A series of experiments were made by cooling pig iron slowly down to a determined point, cooling out in water by estimating the graphite present at such temperature. It was found that siliceous iron behaves at first like white iron, and that the separation of graphite begins about 30° to 40° C. below the first critical point. The various details of the experiments are fully described, and the results illustrated by a series of curves.

F. Hermann † briefly deals with the principal results of modern metallurgical and specially of metallographical science concerning iron-carbon alloys, and describes the variations which are brought about in the iron by tempering.

W. Gahl ‡ has contributed an able study of the theories in reference to the separation of graphite in high carbon iron alloys. He criticises various views of other observers. The paper is illustrated with curves of the various systems described.

Solidification Points and Transformation in Alloys.—A. Portevin § deals with the phenomena of solidification and the transformation of alloys, and the applications of the phase-rule to equilibrium in a system consisting of two bodies. He recognises the value of the contributions made by the Alloys Research Committee to the theory of the constitution of alloys, and points out that the results achieved are often ignored by those to whom their applications would be useful owing to the fact that, in order to understand them properly, a wider knowledge of physical chemistry is required than persons engaged industrially possess, or than is taught in ordinary technical courses of instruction. At the same time, although phase-rule and kindred conceptions belong to the domain of pure science, it is impossible to grasp the questions involved in the properties and rational treatment of alloys, without understanding the diagrams of equilibrium which have been constructed with a view to elucidating the problems such alloys present. Another disadvantage which presents

* *Stahl und Eisen*, vol. xxvii. pp. 1565-1571, 1621-1625.

† *Giesserei Zeitung*, vol. iv. pp. 641-644.

‡ *Stahl und Eisen*, vol. xxviii. pp. 225-229.

§ *Revue de Métallurgie*, vol. iv. pp. 915-925.

itself to those who desire to make themselves acquainted with the subject is the absence of any summary of the investigations which have preceded the formulation of the principles involved. He therefore seeks to condense in a short space an account of the phenomena and a statement of the laws which govern the consideration of alloys. This is done from the point of view of their ultimate dependence on the principles of thermodynamics. The phase-rule, as it obtains in a system composed of two bodies, is then defined. The conditions of equilibrium of a system composed of two bodies is deduced directly from the law of equilibrium in heterogeneous systems or Phase Law, the law itself having been derived, by W. Gibbs, from the principles of thermodynamics, and its applications confirmed by the investigations of numerous observers, such as Van t'Hoff, B. Roozeboom, H. Le Chatelier, and Tammann. If a mixture of two bodies in equilibrium, under definite conditions of temperature and pressure, be considered, it will either form a single homogeneous mass, or it will separate into a certain number of solid homogeneous bodies, liquid, solid, or gaseous, not miscible with each other, and each characterised by its composition, or the proportion of each of the two bodies they may severally contain. These homogeneous bodies have received the name of phases, and may be distinguished from one another by their composition, or one of their physical properties, density, physical state, or crystalline system, the distinctive and essential characteristic of two phases in equilibrium being always their non-miscibility. Thus two non-miscible solids or liquids, or a liquid and an insoluble solid, in equilibrium form as many systems composed of two phases. These phases may be continuous or discontinuous. A mixture of water and oil is a two-phase system, whether the oil and the water form two superposed layers, or whether the mixture be emulsified by agitation, and the oil disseminated in suspended globules throughout the water. The term "variancy" is applied to the number of conditions determining the state of a system (the composition of the phases, temperature, &c.) which can be arbitrarily varied without destroying equilibrium. For a two-body system maintained at constant pressure the relation between the variancy, V , and the number of phases is expressed by the formula $V = 3 - \phi$. The laws of equilibrium depending on the value of V are stated for three conditions: (1) $V < 0$ (negative variancy); (2) $V = 0$ (invariancy); and (3) $V = 1$ (univariancy), after which the results of these laws, so far as they affect solidification, are discussed and explained, by the aid of diagrams and formulæ, and the phrases "solid solution" and "mixed crystals" are explained and defined, together with the transformation points, and a description of the conditions causing eutectism, or eutecty. The foregoing considerations are next employed to explain transformations taking place in a solid solution, and the influence thereon of the rate of cooling. The state of unstable equilibrium in a supersaturated system is facilitated by the addition of a few crystals of the unstable constituent. Thus in antimony-cadmium alloys it is possible to observe the solidification and depo-

sition of Sb-Cd corresponding with stable equilibrium, and the solidification and deposition of the compound Sb_2Cd_2 , corresponding with unstable equilibrium. Of these conditions a remarkable example is furnished by the iron-carbon alloys, stable equilibrium amongst which corresponds with the presence of graphite, while unstable equilibrium corresponds with the presence of the carbide Fe_3C .

Magnetic Properties of Iron and Steel.—Ernest Wilson * gives the results of experiments on the effects of induction in an iron cylinder when traversed by alternating currents.

W. H. Walker † gives the results of an elaborate research on the influence of electromotive force on the structure of iron.

P. Weiss ‡ determined the intensity of magnetisation at saturation for both soft and Swedish iron at ordinary temperatures as 1731 gauss.

J. Sahulka § describes the measurement of the loss of iron in alternating current working. In another paper || he describes a method of rapidly determining the relation connecting the core loss per cycle with the frequency, and gives a number of results showing that this loss increases with the frequency. The effect of wave form on the loss per cycle is also investigated.

W. H. F. Murdoch ¶ describes a simple permeameter for workshop testing of iron, which has the advantage that the material tested may be in very large pieces. The accuracy aimed at is about 5 per cent., and the necessary readings can easily be taken.

E. Haupt ** describes an apparatus designed for testing cores and armatures of relays, &c. The movable part of the instrument consists of an astatic system formed by two vertical needles held in a delicately pivoted frame. A fine spiral spring forms the controlling couple. Two horizontal solenoids are arranged in a vertical plane, and the direction of the currents is such that the couples exerted by the solenoids on the astatic system balance each other. If the sample to be tested is introduced into one of the solenoids the balance is distributed, and by gradually increasing and then decreasing the current the magnetic behaviour of the sample may be studied by noting the corresponding angles of torsion. The angle of torsion is proportional to the intensity of magnetisation. By means of a sample of known magnetic qualities absolute values can be obtained.

T. M. Barlow †† describes some investigations made on the rate of flow of heat in electrical machines built up of iron forgings. The

* *Proceedings of the Royal Society*, vol. lxxx. pp. 369-378.

† *Transactions of the American Electrochemical Society*, May 8, 1907.

‡ *Comptes Rendus*, vol. cxlv. pp. 1155-1157.

§ *Elektrotechnik und Maschinenbau*, vol. xxv. p. 808.

|| *Electrician*, vol. lx. pp. 330-331.

¶ *Proceedings of the Institution of Electrical Engineers*, vol. xl. pp. 137-158; *Electrician*, vol. lx. pp. 245-246.

** *Elektrotechnische Zeitschrift*, vol. xxviii. pp. 1069-1071.

†† *Electrician*, vol. lx. pp. 554-556.

rate of flow both along the forgings and perpendicular to them is dealt with, and the importance of the amount of edge surface of the stampings exposed to the cooling medium is shown.

A cylindrical bundle of iron wire, 8 metres long and 50 square centimetres in sectional area, is surrounded at one end by a magnetising coil of 400 turns, fed by a three-phase current. L. Donati* calculates the velocity of the wave of magnetism along the wires from the lag of phase at various points along the core, and finds it to be of the order of 1000 metres per second.

Recalescence Curves.—At the Physical Society, W. Rosenhain † described the two principal methods employed for obtaining recalescence curves. These are known as the “inverse rate” and “differential” methods respectively. In the former method the time occupied by successive equal decrements of temperature is observed and plotted against the temperature of the cooling body, thus giving a curve whose ordinates are temperature (t) and dT/dt (T = time) respectively. In the differential method the difference of temperature between the body under observation and a neutral or “blank” body cooling under approximately the same conditions is observed and plotted against the temperature of the body. The physical interpretation, in terms of quantity of heat evolved and of rate of evolution of heat of these two kinds of curves, are discussed by reference to the fundamental curve representing the time-temperature relations of one or two cooling bodies. On both types of curve recalescences are indicated by peaks, and it is shown that in the case of an inverse-rate curve the area of a peak, when taken between proper limits, is roughly proportional to the quantity of heat evolved divided by the rate of cooling. Serious errors affecting this proportionality in practical cases are, however, pointed out. The differential curves are first discussed for the ideal case in which the neutral body cools at the same average rate as the body under observation; but it is pointed out that this case cannot be readily attained in practice. The effect of differences in the rates of cooling of the two bodies is shown to be the production of a general slope in the differential curve, upon which peaks due to recalescences are superposed. The author suggests the elimination of this general slope by plotting a “derived differential curve” in which the movements of the differential galvanometer during the process of cooling through successive intervals of temperature are plotted against the temperature of the cooling body. The curve represents the differential coefficient of the ordinary differential curve. Peaks representing recalescences on these curves are shown to have exactly the same physical meaning as peaks on the inverse-rate curves, and the conclusion is arrived at that the two methods lead to identical results, the choice between them being thus reduced to a question of experimental expediency. The experimental requirements

* *Elettricista*, vol. vi. pp. 241-243.

† *Engineering*, vol. lxxxv. p. 180.

of the two methods are then described, and it is shown that to arrive at the same degree of accuracy in the curves, the means of measuring temperature used for the inverse-rate method must be very much more sensitive than those required for the differential method. This necessity arises from the fact that, in the inverse-rate method, the actual temperature of the cooling body must be determined to the same degree of accuracy as the difference of temperature between the two bodies in the differential method, and while the latter difference rarely exceeds 40° C., the former frequently attains 800° C. The fact that accurate autographic methods appear to be more readily attainable with the differential method is also an argument in its favour, as is also the fact that it is less subject to accidental error from external disturbing causes.

Permanent Deformation of Metals.—G. H. Gulliver * has contributed a paper on some phenomena of permanent deformation of metals, the object of which is to correct a hypothesis suggested in a previous paper in 1905 to explain the origin of the “contractile cross.” It was then suggested that while the somewhat analogous “Lüders’ lines” were due to slipping of the elementary crystals within the crystalline grains of the metal, the contractile cross was the result of the slipping of the irregular crystalline grains themselves over each other. It is now established that for aluminium, and probably for other ductile metals, the phenomena of constriction and fracture are due to excessive “slip-band” deformation, and that the contractile cross passes through the crystalline grains of the metal. It is somewhat influenced by the degree of coarseness of the crystalline structure, but is independent of the directions of the boundaries of the crystalline grains.

Physical Properties of Cast Iron.—J. Christie † discusses some of the physical properties of cast iron. Cast iron offers a high resistance to compressive stress, and although this resistance varies within wide limitations, it may be assumed as a working basis to be about six times that of the tensile strength, or, say, 95,000 lbs. per square inch of section. Cast iron is imperfectly elastic, as compared to the superior forms of the metal. It presents no definable elastic limit, and exhibits marked permanent set, under low loads, either in tension or compression. Experiments continued for several years indicate that when loads exceeding one-half the ultimate are applied, failure eventually ensues. It may, therefore, be assumed to have a practical elastic limit in tension of about one-half the breaking load. The coefficient of elasticity is likewise variable, in contradistinction to the constancy of the elasticity, under ordinary conditions, of wrought iron and steel. Recorded experiments indicate that the modulus of elasticity varies considerably in extreme cases, and is nearly alike in

* *Proceedings of the Institution of Mechanical Engineers*, 1907, pp. 519-524.

† Paper read before the Engineers’ Association, Philadelphia; *Iron and Coal Trades Review*, vol. lxxv. no. 1763-1764.

tension and compression. A modulus of 13,000,000 lbs. appears to be a fair valuation for direct tension and compression; or, for bending loads applied transversely, this modulus appears to average 16,000,000 lbs. when used in computation with the commonly accepted formula for flexure. It is a safe general rule for ordinary cast iron in machine structures to limit tensile stress to 4000 lbs. per square inch of section, in the most favourable circumstances; to 3000 lbs. when loads are suddenly applied; and to 2000 lbs. when the force alternates in direction; these unit loads to be further limited to suit the ratio of length to section, as required for columns or any members in alternate extension or compression, or for beams or members subjected to alternating transverse stresses.

H. M. Lane* discusses the relation between the percentage of impurities to the volume of cast iron.

W. Pinegin,† in a memoir covering sixty-eight pages, gives the results of experiments on the relations between the resistance to bending and the tensile strength of cast iron.

Theory of Case-hardening.—F. Wüst ‡ deals with the theory of case-hardening. From metallographic and chemical experiments the author comes to the conclusion that the removal of carbon takes place in two phases. The first consists in the decomposition of the iron-carbide with the formation of temper-carbon, and the second in the oxidation of this latter by oxidising gases, which are given off from the surrounding iron oxide.

F. Hermann § discusses the changes in iron on hardening.

Bending Tests.—H. Riall Sankey || gives the results of tests made with a testing machine by means of which the quality of materials may be determined by the number of bends required to produce rupture and form the effort necessary to effect the bending. Tests were made with the eight types of steel experimented upon by the Alloys Research Committee.

E. Meyer ¶ shows that it is possible to determine graphically the bending of rods of various sections if the extension curve of the material is known.

T. von Karman ** also deals with bending tests.

Impact Testing.—E. Ehrensberger †† has made experiments on notched bars in three Charpy pendulum-type machines specially made

* Paper read before the American Society of Mechanical Engineers; *Iron Trade Review*, vol. xii. pp. 970-971.

† *Mitteilungen über Forschungsarbeiten auf dem Gebiete des Ingenieurwesens*, No. 48. Berlin, J. Springer.

‡ *Metallurgie*, vol. v. pp. 7-12.

§ *Giesserei Zeitung*, vol. iv. pp. 641-644.

|| *Engineering*, vol. lxxxiv. pp. 829-831.

¶ *Zeitschrift des Vereines deutscher Ingenieure*, vol. liii. pp. 167-173.

** *Physikalische Zeitschrift*, 1908, p. 136.

†† *Zeitschrift des Vereines deutscher Ingenieure*, vol. li. pp. 1974-1982; *Stahl und Eisen*, vol. xxvii. pp. 1797, 1833.

for the work, the maximum energy of blow available being 1808, 542, and 72 foot-pounds respectively. The energy absorbed in fracturing carbon steels and cast steels showed great variations and apparently no connection with elongation. The shock strength in a number of nickel and nickel-chromium steels is very high. Notches with sharp corners give lower values of resistance to shocks than rounded notches. A specification is proposed for adoption for tests of this kind.

Testing Hardened Steel.—R. Stribeck* describes tests which were carried out with chromium steel and partly with carbon steel. He gives exact data concerning the elastic and permanent elongations, and the percentage of elongation. The latter for hardened material was about 5 to 7 per cent. greater than for unhardened material. Data concerning the compressive strength and of the method of carrying out compression tests are given. In several experiments oiled brass plates were placed between the compressed surfaces of the sample and the ball to counteract the prevention of transverse elongation near the compressed surfaces. Bending tests were made to find the tensile strength, being recommended as more suitable than tensile tests, because the latter with completely hard material encounter difficulties. With the bending tests completely hard material gave tensile strengths up to 412,510 lbs. per square inch. Further numerous experiments have shown that, with hardened steel balls of different diameters, or against a similar ball of the same diameter, which are pressed against a plane or a concave spherical surface, even after permanent deformation the average pressures are equal, if the loads selected are proportional to the squares of the diameters. The elastic compression of balls gave results which correspond to the values calculated by the Hertz formula. A hardened ball tested between two similar balls was destroyed at the diameter of the compressed surface, which would have been attained with a slowly increasing load by a strain equal to two-thirds of the breaking strain. If the load was released at two-thirds of that strain, which with a further increasing load would have occasioned fracture, then the fracture of the ball would take place, and in some cases even after a few minutes. At a lower strain before fracture cracks appear concentric to the contact surfaces, to which with further increased load radial cracks associate. With polished balls, cracks and fracture take place at considerably lower strains than with unpolished balls. The author concludes that the best method of hardness-testing is by pressing together two balls of equal diameter.

In a lecture given at a meeting of the Sheffield Society of Engineers, J. O. Arnold,† dealing with the question of testing structural steels, proposed to abandon the maximum stress as the base for the factor of safety, and to take the yield point as a datum line, deduct

* *Zeitschrift des Vereines deutscher Ingenieure*, vol. li. pp. 1445-1451, 1500-1506, 1542-1547.

† *Engineer*, vol. civ. p. 597.

from this 4 tons, and, on the remainder, to use a factor of safety of at least 3 to 1.

Constituents of Hardened Steels.—P. Breuil* replies to the criticisms of L. Guillet on his researches on the constituents of hardened steels. He cites the opinions of Arnold and of Ledebur, which were in opposition to those of Guillet, and contests his statements as to the conclusions to be drawn from the facts recorded in the original paper on the constituents of hardened steels.

Tests of Hollow Cylinders.—C. Bach † describes tests of three cast-iron cylinders under internal pressure. The first had no stiffening ribs. The second had circumferential and longitudinal ribs 50 millimetres high, and the ribs of the third were 100 millimetres high. All the cylinders were 20 millimetres thick, with an internal diameter of 500 millimetres and a length of 1450 millimetres. The bulging of cylinders under pressure with longitudinal and circumferential ribs is, with regard to the increased quantity of material required, greater or very little less than with cylinders without ribs. It is more advantageous to use ribs of moderate height and to increase the thickness of the cylinders.

Formation of Cracks in Plates.—According to R. Baumann ‡ a tendency to cracks in boiler-plates can, in addition to an unsuitable design of the boiler, be caused by defective quality of material, wrong treatment of the plate in the works, or the influences of the working conditions. The inferior value of the material seldom consists in insufficient tensile strength, but more frequently in insufficient toughness. An inadmissible high degree of brittleness can be brought about by an excessive percentage of phosphorus, sulphur, arsenic, oxygen, hydrogen, or nitrogen. A wrong heat-treatment may cause the material to be overheated, or burnt, or too rapidly heated, whereby strains and cracks originate; in the same manner by too rapid cooling stresses can be caused. Such stresses, when no cracks appear and with the exception of burnt plates, can be removed by annealing. Damage to the plates in the boiler-shop by straightening and bending insufficiently heated material, by punching the rivet-holes and similar operations, can also be removed by annealing provided that no cracks have originated. Damage to the plates in the ordinary course of working can, with the present state of knowledge, with difficulty be accepted. However, the plates are exposed to considerable stresses, which easily lead to cracks on heating and cooling the boiler.

The formation of cracks in cast-iron pipes is discussed by F. Kapaun.§

* *Bulletin de la Société de l'Industrie Minérale*, vol. vii. pp. 545-551.

† *Zeitschrift des Vereines deutscher Ingenieure*, vol. li. pp. 1700-1704.

‡ *Ibid.*, vol. li. pp. 1982-1989.

§ *Journal für Gasbeleuchtung*, vol li. pp. 8-9.

Load for Railway Bridges.—K. Zelovich * deals with the dimensions of railway bridges, taking into consideration the new Hungarian standard specification of the year 1907. He gives a short summary of the conditions specified for materials, and mentions that formerly only the tensile strength of wrought iron was considered. It was specified as from 49,780 to 56,890 lbs. per square inch. In Hungary, up to the year 1889, wrought iron was employed in all bridges without exception. In that year the first bridge was constructed of open-hearth steel, which had the following properties: Tensile strength, 48,359 to 62,579 lbs. per square inch; elongation, 19 to 35 per cent.; contraction, 46 to 69 per cent. The chemical composition was:

	Per Cent.
Carbon	0.16-0.33
Silicon	0.01-0.03
Manganese	0.10-0.31
Copper	0.09-0.14
Phosphorus	0.02-0.061
Sulphur	0.01-0.045

The first bridge of mild steel in Austria was erected in the same year. After searching inquiries, a special committee of the Austrian Engineers and Architects Society decided, in the year 1891, that open-hearth steel was a thoroughly trustworthy material for the construction of bridges. Five years later (1896) the same committee decided that steel manufactured by the Bessemer acid process was a suitable material for the purpose, and that it should have a specified tensile strength of from 49,780 to 61,157 lbs. per square inch. The first bridges of steel manufactured by the Bessemer acid process were erected in Germany in 1891 and 1893 respectively, and since then this material and open-hearth steel are frequently employed together. The specifications of different countries are compared, and the present standards are compared with the former conditions, and the weights of old and modern bridges are given. The load allowed in cast-steel bridge bearings is 14,220 lbs. per square inch, and is the same in Hungary and in Austria. Open-hearth steel castings are specified to support a minimum tensile stress of 7395 lbs. per square inch.

The Causes of Damages to Gas-pipes by the Electric Current.—Isidor Bernauer † states that the damages caused by the electric current to gas-pipes can be either of a thermal or chemical nature. The damages of a thermal nature are mostly due to short-circuiting, if the electric conductor is in direct contact with the gas-pipe, and thereby the electric current is led to earth. In such cases the electric current passes suddenly to the gas-pipe, so that the electric conductor is generally burned and the gas-pipe is melted through at the point of contact. Damages of a chemical nature are

* *Magyar mérnök- és építészegylet*, vol. xli., Parts V.-VI.

† *Bányászati és Kohászati Lapok*, vol. xl. pp. 302-306.

caused by the electric current being transmitted to the gas-pipe by means of wet earth or masonry. In such cases the conducting dampness is decomposed by the electric current. The oxygen at the positive pole causes an oxidation of the gas-pipe, or of the insulation of the electric conductor. Many injuries take place owing to the so-called erratic currents. These currents come from the negative conductor of electric railways with conductor above ground, if sufficient care is not devoted to the return conductor. The author explains several cases, and gives photographs of damaged pipes. He explains the causes of the damages and gives his opinion how they could be avoided. The greatest care is necessary in the neighbourhood of electric power stations. The return cables to the central stations should be maintained in good order, and with electric tramways the rail-joints should be properly connected. The cable employed for the return to the station should be well insulated and of sufficiently large section.

C. P. Buchanan * gives the results of a series of failure tests on full-sized compression members of bridges for Pennsylvania lines.

Bursting-point of Flanged Fittings.—Results of a number of tests are given † to determine the average point at which flanged fittings of various sizes would burst under hydraulic pressure. The tests were made by bolting blind flanges to the openings of the fittings and admitting water through a small opening in one flange. Extra heavy-flanged tees were also tested. Using the tees as a basis and the factor of safety of five, the thickness of metal required safely to withstand a head of 3400 feet would be 5 inches if the metal carried its strength through such a thick section, which is not probable. Rankin's rule, with material having a tensile strength of 22,000 pounds per square inch, and the same factor of safety gives a thickness of only 2 inches.

The Action of Toothless Circular Saws.—F. W. Harbord ‡ gives the results of a microscopic examination of the revolving disc and of the material subjected to its action. He finds that the material acted upon is heated at the point of contact to a temperature approaching, if not equal to, the melting-point of steel, and that this high temperature is confined practically to the surface in contact with the disc.

A. Voigt § has investigated the distribution of pressure in iron subjected to the action of a cutting tool. He reviews at length the work of previous authors, and a bibliography is given with references to a large number of papers on the subject. Theoretical attempts to give a general formula are dealt with. The author obtains a formula

* *Engineering News*, vol. lviii. pp. 685-695.

† *Iron Trade Review*, vol. xii. pp. 1040-1041.

‡ *Engineer*, vol. cv. p. 187.

§ *Verhandlungen des Vereins zur Beförderung des Gewerbeisses*, 1907, pp. 443-541; *Stahl und Eisen*, vol. xxviii. pp. 344-346.

to find the internal pressure for points inside the specimen, and describes experiments to test the accuracy of the same. The author draws attention to the probable value of radiographs of metallic particles in different conditions as regards stress.

Strength of Chain-links.—The chain has hitherto received scant attention from investigators in the field of elasticity and strength of materials, and a welcome addition to the two or three scattered memoirs on the theory of the stresses in chain-links is made by a memoir on the strength of chain-links by G. A. Goodenough * and L. E. Moore. The investigation described deals with the development of the theory of the stresses induced in chain-links with given conditions as regards loading, with experimental tests of the validity of the theory employed, and with the assumptions made as to the distribution of pressure between adjacent links, and the deduction, from theoretical considerations alone, of rational formulæ for the loading of chains. Experiments made on steel rings were found to confirm the theoretical analysis employed in the calculation of stresses. Experiments on various chain-links further confirm this analysis. The introduction of a stud in the link equalises the stresses throughout the link, reduces the maximum tensile stresses about 20 per cent., and reduces the excessive compressive stress at the end of the link about 50 per cent. The following formulæ are applicable to chains of the usual form: $P = 0.4 d^2 S$ for open links, and $P = 0.5 d^2 S$ for stud links, where P denotes the safe load, d the diameter of the stock, and S the maximum permissible tensile stress.

Steel Rails.—The specifications for the new standard rails of the Pennsylvania railway system have been published.† For Bessemer steel rails the limit of phosphorus is placed at 0.1 per cent.

Details of new arrangements on the question of price and specification of Bessemer rails, arrived at by manufacturers in the United States and Canada, have been published.‡ The new specification, to which manufacturers have agreed, embodies several new or altered clauses, but does not yet altogether agree with either of the specifications advanced by the bodies representing the purchasers. The subject of "discard" is left open in so far as the actual amount of discard may be decided upon between the purchaser and manufacturer, but a scale is drawn up regulating the prices to be charged. A 9 per cent. discard and rails at \$28 per ton is taken as a basis, and an increase of price of 29 cents per ton is to be made for each additional 1 per cent. discard. Thus with 10 per cent. discard the price will be \$28.29 per ton; 15 per cent. discard, \$28.74 per ton; 20 per cent. discard, \$31.19 per ton; 25 per cent. discard, \$32.64 per ton. The limit of phosphorus still remains at 0.10 per cent., the manufacturers

* *University of Illinois Engineering Experiment Station, Bulletin No. 18.*

† *Engineering*, vol. lxxxv. p. 628.

‡ *Ibid.*, p. 166.

declining to guarantee anything lower than this. A drop test is to be taken for each heat, the height of drop varying from 17 feet to 19 feet, according to the rail section. These are grouped in three divisions—viz., 75 lb. to 79 lb., 80 lb. to 89 lb., and 90 lb. to 100 lb. sections. The tup is to be of 2000 lb. weight, and the supports not less than 4 feet or more than 6 feet apart. A “shrinkage” clause is also introduced, the object of which is to insure the finishing of the process of rolling at as low a temperature as possible. This clause states that for 75-lb. section rails the finishing temperature is to be such that the shrinkage shall not exceed $6\frac{7}{16}$ inches for a 33-foot rail, with a $\frac{1}{8}$ -inch extra allowance for each additional 5 lb. in section. No artificial cooling of the rails will be allowed, neither shall they be held before sawing. With regard to cambering when delivered to the cold straightening presses, they must not be more than 5 inches out of straight over their entire length. It may be added that in most respects this specification approaches fairly closely to that embodied in the majority report presented recently to the American Railway Association by its committee on this question. In this committee’s report, however, the subject of discard was left undetermined, while in a minority report a discard of 20 per cent. was demanded.

The progress report of the special committee on rail sections of the American Society of Civil Engineers has also been published.*

Corrugation of Tramway Rails.—Results are given † that have been deduced from information collected by the Maintenance of Way Committee of the American Street and Interurban Railway Engineering Association on the subject of rail corrugation. The general opinion is that the causes of the trouble are: the rails being insufficiently supported, the web of the rail being weak, faulty track construction, and slipping of the outer wheels on curves.

In a report on corrugations on the upper surface of rail heads presented at the Mannheim Conference of the German Tramway and Light Railways Association,‡ the definite conclusion is arrived at that the material of the rails is strained beyond the elastic limit by the action of the hard tires of the wheels when brakes are applied. This is to some extent in agreement with the conclusions arrived at by W. Worby Beaumont.§

G. L. Fowler || states that there appears to be no relation between the variations in hardness and the positions of the corrugations. In a girder rail of the Boston Elevated Railroad the variations were more pronounced, and were considered to be due to hardening in service, but not to an original property of the steel. The hardness tests were made by the Martel method by allowing a loaded punch to fall on the sample. The standard punch is a four-sided pyramid,

* *Iron Age*, vol. lxxxi. p. 267.

† *Electrician*, vol. lx. p. 158.

‡ *Zeitschrift für Kleinbahnen*; *Electrician*, vol. lx. pp. 167-168.

§ *Journal of the Iron and Steel Institute*, 1907, No. III. pp. 501-502.

|| *Street Railway Journal*, vol. xxx. pp. 506-508.

one pair of opposite edges being inclined at an angle of 60° and the other 9° . The hardness number is $\frac{Wh}{V}$, where W is the total weight of the punch and head to which it is attached, h the height of fall, and V the volume of metal displaced.

Nickel Cast Iron.—L. Guillet* prepared alloys by adding up to 50 per cent. of nickel to a white iron containing 3.2 per cent. total carbon and 0.052 per cent. graphite, and up to 12 per cent. to a grey iron containing 2.739 per cent. total carbon and 1.697 per cent. graphite. As the percentage of nickel increases, pearlite disappears, the cementite commences to be partially of acicular form, sorbite appears, afterwards γ -iron appears, and also troosto-sorbite on the disappearance of sorbite. The separation of graphite is favoured by nickel. By experimenting in a similar manner with manganese instead of nickel, it was found that γ -iron was not formed, and generally sorbite was not obtained. Generally the elements which enter into solution in the iron, nickel, aluminium, and silicon, favour the separation of graphite, and those which form a double carbide, manganese and chromium, oppose this separation.

Iron-tungsten Alloys.—H. Harkort† describes the preparation of a long series of carbonless iron-tungsten alloys. Details are given of their solidification temperatures and microstructure. The author discusses at length the causes of the inconsistent results on solidification of alloys of almost pure iron and tungsten. The transformation temperature, A_{c_2} , is unaffected by addition of tungsten to iron. The temperature from which the sample is cooled appears to be without effect, and the cooling curves appear to indicate the existence of a compound Fe_3W in alloys containing 20 per cent. of tungsten and upwards. With 15.4 per cent. of tungsten there is distinct evidence of mixed crystals in the alloys as made. After heating at 800° the presence of β -iron is recognised, and with 0.7 and 3.38 per cent. of tungsten there was a slight separation of a constituent containing tungsten. With higher percentages, 11.7 and 19.6 of tungsten, there was no doubt of the occurrence of two constituents. Heating to 1200° did not bring about the complete solution of this constituent rich in tungsten.

Iron-chromium Alloys.—H. Wedding‡ gives details of iron-chromium alloys.

H. Wedding§ has investigated the behaviour of a series of alloys of nickel, chromium, and iron on melting as regards mobility, the formation of blowholes, piping of ingots, gases evolved, &c.

* *Comptes Rendus*, vol. cxlv. pp. 552-553.

† *Metallurgie*, vol. iv. pp. 617-631, 639-647, 673-682.

‡ *Verhandlungen des Vereins zur Beförderung des Gewerbfleißes*, 1907, pp. 221-226.

§ *Stahl und Eisen*, vol. xxvii. pp. 1590-1591.

W. Treitschke* and G. Tammann have published some investigations on the alloys of iron with chromium. Early investigations seemed to show that chromium only mixed with iron imperfectly at 1600° C. This, however, is not due to the slight solubility of either metal in the other, but to the fact that molten chromium at temperatures in the neighbourhood of this melting point possess extremely great viscosity, and consequently only mixes with difficulty when left to mix quietly with the highly fluid iron. This difficulty was overcome in this series of experiments by using magnesium vessels instead of porcelain, whereby a heat of 1700° could be obtained. The chromium used is obtained by the Goldschmidt method, and contained 99 per cent. chromium, 0.6 per cent. iron, and 0.5 aluminium. The iron was very low carbon iron, containing only 0.07 per cent. carbon, and a very small percentage of the other materials. The cooling curves were followed down to 600°. The curve of the commencement of solidification is irregular, the minima at about 15 and 40 per cent. of chromium, and maxima at 30 and 90 per cent. of chromium. There is a further irregular curve of arrest-points, and a eutectic at about 1260° between 30 and 40 per cent. of chromium. This shows that this system is one in which equilibrium is not attained, and a compound of iron and chromium forms with difficulty. The authors draw attention to the importance of the maximum temperature attained in making chromium steels.

Ferro-titanium.—C. V. Slocum † gives the results of some experiments on the improvement of iron and steel by the addition of ferro-titanium. Titanium is exceedingly plentiful, and immense deposits of iron ore containing that element are found in the United States and Canada, so that the cost may be brought so low as to be a secondary consideration. In 1890 the St. Thomas Car Wheel Company, Ontario, noticed a peculiar hardness in the tread of certain wheels which was subsequently found to be due to the presence of titanium. Extraordinary mileages were obtained from these wheels, an engine-wheel having made more than 200,000 miles with a wear of less than one-eighth of the chilled surface all round. The results obtained in a small blast-furnace erected for the smelting of titaniferous iron ores, and having a capacity of 3 to 4 tons per day, are described. Later A. J. Rossi made ferro-titanium in a small electric furnace at Niagara Falls. The alloy was made in flat lumps which were exceedingly hard, and in some instances could not be broken, and had to be remelted before using. On test bars 1 inch square and 12 inches long the transverse strength of a strong mixture was raised by the addition of 0.5 per cent. of a 10 per cent. titanium alloy, from 3000 lbs. breaking strain to 3600 lbs., and a weak mixture made expressly for the experiments had its strength increased from 2100 lbs. to 2950 lbs. The opinion of F. C. Weber is quoted to the effect that titanium introduced as an alloy at once combines with the gaseous

* *Zeitschrift für anorganische Chemie*, vol. lv. pp. 400-411.

† *Iron Trade Review*, vol. xli. pp. 793-796.

nitrogen present in the molten metal to form a stable nitride, and reference is also made to the work of Rossi on titaniferous pig iron.

Testing-Machines.—J. H. Wicksteed * deals with the use of large testing-machines. The largest machine for testing bridge struts or columns in compression is a machine of English manufacture installed at the Conservatoire des Arts et Metiers at Paris. It will test a column 80 feet long with a base plate attached measuring 20 feet by 3 feet 3 inches and a capitol 3 feet 3 inches by 3 feet 3 inches. This is double the capacity for testing struts or columns of any other machine at present in existence.

W. J. Lambert † describes a method of determining the extension of test-pieces in tensile tests. He describes a method of measuring the extension of test-pieces under tensile stress in order to determine the modulus of elasticity. Two knife-edges are fixed to the test-piece in such a manner that they lie in the same plane and immediately opposite each other. When the test-piece is extended the distance between the knife-edges is magnified 100 diameters, and is projected by a photomicrographic apparatus on to a screen. The width is measured by means of a sliding vernier, and the extension is thereby measured to 0.00001 inch.

A. Martens ‡ describes the results of investigations into the limitations and possibilities of the hydraulic diaphragm measuring principle as applied to testing-machines. The ratio between the width of the unsupported portion of the diaphragm and the thickness of the diaphragm should be small. Soft brass is preferable to steel. Gauges can be constructed of this type which will indicate accurately to within plus or minus 1 per cent. with a hydraulic pressure of 100 atmospheres. The combination of a diaphragm box with two recording gauges, one to control the other, is recommended.

Elastic Properties of Steel.—O. Wawrzyniok § gives complete tensile tests for a series of seven carbon steels containing from 0.63 to 1.13 per cent. of carbon, but otherwise almost similar in composition. As the carbon increases the modulus of elasticity expressed in kilogrammes per square centimetre decreases from 2,098,000 with 0.63 per cent. of carbon to 2,121,000 with 1.13 per cent. of carbon. The effect of annealing appears to be uncertain; there is a tendency to low values after annealing at 500°, and to higher values at 600° or 700°. The results of similar tests upon three chromium steels containing 0.95 per cent. carbon and 0.60 per cent. chromium, 1.18 per cent. carbon and 0.66 per cent. chromium, and 1.70 per cent. carbon and 0.97 per cent. chromium respectively. The elastic limit, tensile strength, and elongation were considerably lowered, and the modulus of elasticity slightly raised by annealing.

* *Times Engineering Supplement*, November 20, 1907, p. 3.

† *Minutes of Proceedings of the Institution of Civil Engineers*, vol. clxix, pp. 349-351.

‡ *Mitteilungen über Forschungsarbeiten des Vereines deutscher Ingenieure*, No. 88.

§ *Metallurgie*, vol. iv, pp. 810-815.

At the Royal Society's soiree on May 13, the Cambridge Scientific Instrument Company showed a form of extensometer, for measuring the stretch of test-pieces under tension. The test-bar is first placed in a jig, and two pairs of dots are punched in it, 100 millimetres apart, each pair being for the location of one of the two attachments between which the stretch of the test-piece is to be measured. By an arrangement of levers the extension of the test-piece causes the edge-wise movement of a springy blade of steel. This steel is set vibrating by hand, and a micrometer screw is adjusted until a sharp steel point comes into contact with the end of the blade. This, of course, makes a sound, and brings the blade rapidly to rest, forming a means of adjusting the micrometer with extreme accuracy. When the test-piece is loaded by a fresh amount, the micrometer is again brought into contact with the reed, and difference in reading noted. The divisions on the micrometer head are engraved on white celluloid, and are about a millimetre apart. One complete division corresponds to a stretch of the test-piece of 0.001 millimetre, and as a fair estimation can be made of a tenth of a division, the reading may be taken to 0.0001 millimetre. The expansion of the test-piece by the heat of a finger brought into contact with it can be easily observed.*

The equipment of the mechanical testing-laboratory of the Stuttgart Technical School is described by C. Bach.†

A. Martens‡ gives the results of extensive tests of hydraulic diaphragm testing-machines.

Reinforced Concrete.—The theory of ferro-concrete and the materials employed in its construction are discussed.§ The steel should take the tension stresses and the concrete the compression stresses. The steel should be ductile, of a tensile strength from 27 tons to 32 tons per square inch, with an elongation of at least 20 per cent. on an 8-inch specimen. Sound open-hearth basic or acid steel coming up to these requirements is suitable for reinforced concrete work. High-carbon steel is unsuitable owing to its brittleness, which would occasion sudden failure of the work should its limit of elasticity be overstepped. Although Bessemer steel may be somewhat cheaper, its variable and lower quality renders it an unsuitable metal to be employed. Bessemer basic steel should be absolutely excluded owing to its brittleness, due to excess of phosphorus left in the finished product from the pig iron. In the Hennebique system it is immaterial as to what form the steel may take, but as the most economical form and the best in every way is the round bar, that is the form usually employed; the stirrup steel to resist the shearing strains being made of flat bars. The adherence of good concrete and

* *Engineering*, vol. lxxxv. p. 658.

† *Zeitschrift des Vereines deutscher Ingenieure*, vol. lii. pp. 241-243.

‡ *Engineering*, vol. lxxxiv. pp. 861-862.

§ Paper read before the British Association, Leicester, by J. S. E. De Vesian, August 6, 1907; *Iron and Coal Trades Review*, vol. lxxv. pp. 646-647.

steel varies from about 500 lbs. to 700 lbs. per square inch of surface in contact. Twisting and squeezing only weaken the metal and make it necessary to increase the weight used to obtain equal results.

Specifications.—R. Moldenke* discusses specifications for iron and steel. The subject is dealt with under the following heads: Carbon, machinery and malleable castings, light castings, fuel for foundry work, coke, ferro-alloys, scrap, moulding sand, and commercial castings.

New rules relating to rivet-stays and appendages, with tables of margin of safety, dimensions, &c., have been issued by the Massachusetts Board of Boiler Rules.†

Summaries of the majority and minority reports withdrawn by the Executive Committee from the Convention of the American Railway Associations Committee on standard rail and wheel sections, at the November meeting in New York, have been given.‡

The National Physical Laboratory.—In accordance with the instructions contained in a Treasury Minute of the 31st December, 1906, a committee, composed of G. Balfour, Sir Andrew Noble, Sir J. Wolfe Barry, W. J. Crossley, and R. Chalmers, was appointed to inquire generally into the work now performed at the National Physical Laboratory, with special reference to the character of the mechanical, physical, and chemical tests undertaken there; the possibility of their interfering unduly with the business of other agencies; and the desirability of publishing the results of all such testing work. The committee have now issued their report.§

Standard Notation.—Attention was drawn at a meeting of the Civil and Mechanical Engineers' Society to the existing confusion in notation for engineering formulæ, and a resolution was passed "That, in view of the desirability of adopting as far as possible a standard notation and nomenclature for engineering formulæ, this meeting of the Civil and Mechanical Engineers' Society requests the Council to approach the Engineering Standards Committee, the universities having engineering faculties, the leading engineering institutions, societies, and associations in the British Empire, with the object of bringing about concerted action in the matter, or to take such steps as may, in the Council's opinion, best conduce to this end." There can be no question that the existing confusion in engineering notation, particularly in connection with structural work, is to be regretted, and a well-considered attempt to introduce standardisation calls for commendation. Wise discrimination has been exercised in confining the scheme to notation, as the standardisation of definitions and nomenclature is a problem of far greater complexity. Useful

* *Iron Trade Review*, vol. xli. pp. 926-928.

† *Iron Age*, vol. lxxx. pp. 1165-1166.

‡ *Ibid.*, p. 1325.

§ Cd. 3926 (1908).

work has already been done in various directions by the Institution of Electrical Engineers in standardising electrical definitions, nomenclature, and notation by the International Testing Association, and the Iron and Steel Institute in dealing with the nomenclature of iron and steel, and by the Institute of Mining and Metallurgy in dealing with mining weights and measures. The work already done needs, however, to be co-ordinated, and, as far as possible, brought into line with the decisions arrived at by Continental societies.*

* *Mining Journal*, vol. lxxxiii. p. 141.

CHEMICAL PROPERTIES.

Passivity of Iron.—H. L. Heathcote * gives the results of an investigation on the passivifying, passivity, and activifying of iron.

Occluded Gases in Steel.—G. Belloc † deals with the occluded gases in steel. With a very mild steel containing 0.12 per cent. of carbon and 0.35 per cent. of manganese, the relation between the rate of evolution $\frac{dv}{dt}$ and the temperature t at which samples of turnings were heated for several days, was as follows. The evolution commenced at from 150° to 400°. $\frac{dv}{dt}$ had a minimum value at about 200°, and a maximum at about 400°. Between 500° and 600° there was a high maximum, falling to a minimum with the termination of interval A2. With the commencement of A3 the evolution rose, then fell, and continuously rose with further increase of temperature. Upon heating to 1200°, a volume of gas equal to from eleven to twelve times that of the steel was extracted. Up to 400° the gas is almost entirely carbon dioxide, which disappears at about 550°; above 400°, hydrogen and carbonic oxide; above 550° a quantity of nitrogen not exceeding 10 per cent. of the total gas appears. The experiments show the improbability of the existence of a state of dissociation of the gases occluded in the steel.

O. Boudouard ‡ notes the many investigations which have been made on gases occluded in iron and steel, and points out that while their important influence on the formation of blowholes is well known, the condition in which they exist in the metal is as yet unknown. The results obtained by Parry, who showed that by heating a steel several times in a vacuum diminishing volumes of gases are obtained, are commented on. In the author's own experiments he studied the conditions under which the occluded gases could be extracted. He used a piece of merchant bar having 1 square centimetre in section, and containing 0.099 per cent. of carbon; a piece of sheet 1 millimetre in thickness, with 0.13 per cent. of carbon; and wires 2 millimetres, 1 millimetre, and 0.5

* *Journal of the Society of Chemical Industry*, vol. xxvi. pp. 899-917.

† *Comptes Rendus*, vol. cxlv. pp. 1280-1283

‡ *Revue de Métallurgie*, vol. v. pp. 69-74.

millimetre in thickness, containing 0.188 per cent., 0.074 per cent., and 0.047 per cent. of carbon respectively. The apparatus employed and the conditions under which the gases were extracted are described, and tables given summarising the results of the experiments. Incidentally the experiments revealed the fact that iron heated in a vacuum commences to volatilise at 900° C., and that this volatilisation becomes pronounced at 1100° C.

O. Boudouard* gives in the following table the weight per cent. of gases extracted from samples of iron wire and bar by heating to 1100° three times:—

Metal.	CO ₂ .	H.	CO.	N.	Total.
	Per Cent.	Per Cent.	Per Cent.	Per Cent.	Per Cent.
Wire, 0.5 millimetres in diameter .	0.035	0.0032	0.047	0.0105	0.0957
Wire, 1 millimetre in diameter .	0.035	0.0017	0.062	0.0042	0.1029
Plate, 1 millimetre thick .	0.012	0.0018	0.081	0.0042	0.099
Strip cut from 1 square centimetre bar	0.021	0.0056	0.18	0.0141	0.2207

The method employed is too slow to be of use as a direct method of estimation of nitrogen.

H. Braune † has given an exhaustive account of the occurrence of nitrogen in iron and steel, and of its influence on physical properties. He points out that during the last ten years pig iron of a particular quality has, from time to time, been obtained from Swedish blast-furnaces, the wrought iron obtained from which has revealed inexcusable qualities of brittleness and inelasticity. The chemical composition of the pig iron has not varied to any notable extent from that of pig iron yielding excellent iron; the percentage of sulphur and phosphorus has, at times, been unusually low, but the proportions of silicon and manganese have been those usually encountered. In order to explain the anomalies the following explanations have been put forward: (1) That the percentage of carbon in the pig iron was unsuitable; (2) that arsenic was present, and, in combination with sulphur and phosphorus, gave rise to compounds which affected adversely the nature of the iron even when the separate amounts of these elements were insufficient to influence the result; (3) that the pig iron contained considerable volumes of occluded gases, the nature of which was not specified, while scientific opinion would not consent to regard nitrogen as being one of them. All these theories were, in turn, rejected, and there remained only the hypothesis of the introduction of some new element during the process of manufacture. Investigations carried out on a large number of Swedish pig irons in

* *Comptes Rendus*, vol. cxlv, pp. 1283-1284.

† *Bulletin de la Société de l'Industrie Minière*, vol. vii, pp. 489-544.

1900–1901 showed that the particular type of pig iron was produced when the temperature of the blast-furnace exceeded a particular limit, while it was also found that by employing a basic slag and a high temperature of fusion there was produced, in the lower portions of blast-furnace, a white substance which on analysis proved to be cyanide of potassium. This substance has only been met with in Swedish furnaces during the last ten years, a period coeval with the introduction of highly basic fluxes, high temperatures of working and increased production, whereas it had been frequently encountered elsewhere, notably at the charcoal blast-furnaces in Styria, and at the blast-furnace at Mariazell, where it had been obtained in such quantities that it had been recovered for use in electrolytic processes. Circumstances led to the suspicion that there was a connection between the production of the inferior pig iron in question and the formation of cyanide. Now, it had been recognised that iron was capable of absorbing nitrogen from molten potassium cyanide, and all these circumstances appeared to indicate that the foreign substance introduced was nitrogen, the more so as chemistry had taught that such a reaction between iron and nitrogen was quite possible.

According to Mendelejeff's periodic law, nitrogen, phosphorus, arsenic, antimony, and bismuth belong to the same group, nitrogen being the most electro-negative, and bismuth the least. All these elements are deleterious to the quality of iron, and the more so in proportion as they are electro-negative. Nitrogen, the most electro-negative of the five, would, *a priori*, exert the most injurious influence.

The theory that the presence of nitrogen renders iron hard and brittle dates back to about the year 1850, when the French school of chemists regarded this element as one of the constituents of steel, and believed that it entered in considerable amounts into the composition of iron. Later researches having shown that the amounts of nitrogen present in iron were extremely small, the theory of the influence of nitrogen on the quality of iron had been abandoned. A. H. Allen * in 1880 made some experiments to explain in what way the presence of nitrogen could render iron brittle, but his investigations only served to confirm the view that it had very little influence on pig iron, and he himself regarded it as a metallurgical curiosity. In 1888, however, Tholander † reverted to the theory, and pointed out that the influence of small quantities of nitrogen, introduced in various stages of the manufacture of iron, should not be lost sight of.

In 1903 Braune commenced to analyse different samples of iron and steel, made by different methods, and observed that the absorption of nitrogen by iron was not peculiar to blast-furnace reactions, but occurred whenever a basic slag, nitrogen, and fuel at an elevated temperature reacted on iron. He now gives the results of further investigations at Basle, Zurich, and Paris.

* *Journal of the Iron and Steel Institute*, 1879, No. II. p. 480; 1880, No. I. p. 181.

† *Jernkontorets Annaler*, vol. liii. p. 429.

Nitrogen is encountered under two conditions in iron, the free state and combined. Investigations on its occurrence in the free state have been made by Müller, Stead, Pattinson, and others, and the following table shows the volumes present in steel and iron made by various processes :—

Nature of Specimen.	Nitrogen.	Hydrogen.	Carbon Monoxide.
	Per Cent.	Per Cent.	Per Cent.
Bessemer rail steel	9.7	90.3	0.0
Bessemer spring steel	18.1	81.9	0.0
Bessemer rail steel before introducing spiegel	10.5	88.8	0.7
Bessemer steel for rails after addition of spiegel	23.0	77.0	0.0
Steel before hammering	5.9	92.0	1.4
Steel after hammering	23.3	73.4	1.3
Open-hearth steel	30.8	67.0	2.2
English hæmatite pig iron low in manganese	44.0	52.1	3.9
High manganese pig iron	35.5	62.2	2.8

Nitrogen in chemical combination cannot occur in iron simultaneously with the presence of an acid, as, in all commercial descriptions of iron and steel, carbon occurs, and this element, at the high temperature at which iron is produced and manipulated, has more affinity for acids than any other element. In these circumstances there are only two possible combinations to be met with, nitride of iron and cyanide of iron.

If a cyanide of iron occurs in iron it must necessarily be a ferrous compound. In a reducing atmosphere the ferrous cyanide is stable up to 430°C ., above which it decomposes into iron carbide and nitrogen. This carbide being formed by these means at a much lower temperature than ordinarily, it follows that, when it occurs thus, it is derived directly from the ferrous cyanide by liberation of the nitrogen. Thus it follows that the cyanide cannot exist in iron at a red heat. It might be conceived that the free nitrogen liberated within the iron might react on the carbide during cooling to regenerate cyanide, but this is not likely. Various chemical considerations which might affect the nature or sequence of the reactions occurring are discussed, the conclusion being ultimately arrived at that the nitrogen present in iron is not in the form of a cyanide compound.

Attention is next directed to the nitrides of iron, of which there are two, both well known, Fe_4N_2 and Fe_5N_2 . The first of these, which is sometimes inaccurately written Fe_2N , and is known as tetraferro-diammonium, can be prepared by conducting ammonia over iron reduced by hydrogen, the operation being carried out at the temperature of dissociation of ammonia, or by heating ferric chloride in an atmosphere of ammonia. The second nitride, Fe_3N_2 , was obtained

by Rogstadius on heating reduced iron to a white heat for five hours and subjecting it to an ammoniacal atmosphere, while Frémy obtained a film of the substance on the surface of small iron cylinders treated to redness in an atmosphere of ammonia. In view of the importance of ascertaining definitely whether iron and nitrogen do combine directly with each other, recourse is had to the researches of Baur* and Voermann, which show with certainty that iron and free nitrogen cannot, in any of the conditions accompanying the manufacture of iron, combine with one another.

Nitrised iron is either a grey powder or a silvery and very hard substance, a bad conductor of electricity, and possessing feeble magnetism. All compounds are decomposed at temperatures but slightly above their temperatures of formation, 600° to 7000° C. At higher temperatures decomposition takes place more rapidly, but it never becomes so complete but that small quantities of nitrogen remain in the iron, and may be estimated by means of methods which are described in great detail.

The physical effects of the presence of nitrogen are then investigated. Its occurrence having been proved it became necessary to ascertain its effects, and for this purpose to prepare samples containing varying proportions of nitrogen. For this purpose the property of iron of absorbing nitrogen when heated at 600° to 800° in a current of dry ammonia, was made use of. The arrangement of the apparatus and the sequence of operations are described and illustrated. By the means employed it is possible to prepare samples containing from 0.0 per cent. to 7 per cent. of nitrogen, and even higher if desired. The samples absorb hydrogen as well as nitrogen, under the conditions described, but the hydrogen escapes in the course of a few days, whereas in the experiments in question the samples were first heated to redness, and then laid aside for three months before being subjected to the tests.

Experiments made to ascertain the influence of nitrogen on the appearance of the fractured surface of iron and steel were inconclusive. Experiments were afterwards undertaken as to the influence of nitrogen on the strength, hardness, and elasticity of iron and steel on their magnetic and electrical properties and on their structure, numerous photomicrographs being given to show the effects of the presence of this element. In conclusion the author states his belief that the peculiar excellence of Swedish iron is mainly due, not so much to their general purity as to their comparatively uniform lowness in nitrogen.

A. Sieverts † states that iron showed a certain discrepancy between different samples. The occlusion and diffusion of hydrogen begin at 400°. A sample of reduced iron absorbed nitrogen at 900°, but liberated it on cooling. Nickel absorbs hydrogen below 200°, and diffusion may be detected from 450° upwards. Diffusion and

* *Zeitschrift für physikalische Chemie*, vol. lii. p. 467.

† *Ibid.*, vol. lx. pp. 129-201.

occlusion do not appear to be closely related to one another; diffusion may be rapid with very small occlusion. The velocity of diffusion always increases with the temperature. The activity of hydrogen as a reducing agent in the pressure of nickel is attributed to occlusion.

Direct Union of Carbon and Hydrogen at High Temperatures.—The conditions under which direct union of carbon and hydrogen takes place at high temperatures are discussed by J. N. Pring* and R. S. Hutton.

Colour of Ferric Oxide.—L. Wöhler † and C. Condrea discuss the various colours of ferric oxide, and show that the variation is due to the size of the grains. The violet colour was obtained with salt, and was found to contain pure ferric oxide. The violet and the brown colour were converted into orange by grinding and sliming.

Iron Salts.—Some complex iron salts in which the iron is masked are described by P. Pascal. ‡ He also describes § a similar new series of ammonio-ferric salts.

Experiments on the reducing and oxidising power of salts of iron are described by E. Müller || and F. Kapeller.

Ferro-silicon.—The chemical properties of high-percentage ferro-silicon are discussed by J. Haas. ¶

B. Neumann ** describes a new way of making iron alloys low in carbon. He points out the importance of having low carbon in the alloys to be added to the finished steel bath, and states that the cost of such alloys rises in inverse proportion to the carbon contents. He has experimented with high-grade ferro-silicon as the reducing agent, using a small Heroult electric furnace, and carrying out the reaction between the ferro-silicon and the oxide to be reduced, under a neutral slag composed of molten aluminate of lime. Details of reduction experiments with the oxides of chromium, molybdenum, tungsten, and titanium are given.

Diamond and Carborundum Crystals in Steel.—D. C. Tschernoff †† discusses the occurrence of carborundum and of diamond crystals in steel. Microscopic observations carried out in 1868 and 1869 by the author on fractures of ingot steel, led to the discovery, at the surface edges of the cracks, of tiny transparent crystals in the fractures of a bar of crucible steel slowly cooled. These crystals

* *Transactions of the Chemical Society*, vol. lxxxix. pp. 1591-1601.

† *Zeitschrift für angewandte Chemie*, vol. xxi. pp. 461-486.

‡ *Comptes Rendus*, vol. cxlvi. pp. 231-233.

§ *Ibid.*, pp. 279-282.

|| *Zeitschrift für Elektrochemie*, vol. xlv. pp. 76-82.

¶ *Chemiker Zeitung*, vol. xxxii. p. 8.

** *Stahl und Eisen*, vol. xxviii. pp. 356-360.

†† *Revue de Metallurgie*, vol. v. pp. 79-80; *Memoires de la Société Technique Russe*. July and August, 1907.

scratched glass with ease, and possessed a high power of defraction. Although hexagonal, they exercised no influence on polarised light, which led their author to suspect them of belonging to the cubic system. After many ineffectual attempts to separate certain crystals he succeeded, but, being compelled later to abandon his investigations, he placed some crystals, together with pieces of the metal from which they had been extracted, at the disposal of Osmond in 1900. A brief description of the investigations conducted by that observer and by Moissan, which led to the crystals being identified with diamond and carborundum, is given.

Composition of Slag in Cast Steel.—In the blowholes in the interior of cast steel are frequently found what has been believed to consist of pure ferrite, in the form of octahedral crystals. Three specimens of such crystals have been examined by A. Bajkow,* and the results are as follow:—

	Crystal No. 1.	Crystal No. 2.	Crystal No. 3.
	Per Cent.	Per Cent.	Per Cent.
Carbon	0·78	0·54	0·98
Manganese . . .	1·06	0·89	0·78
Sulphur	0·26	0·17	0·08

All three were shown by micrographic examination to contain inclusions of slag, which generally were uniformly distributed in crystals belonging to the regular system. It is believed that the slag is the first constituent to be crystallised out of the fluid mass, because each fragment of slag was found enclosed by an envelope of ferrite, and the latter by one of pearlite. In the opinion of A. Bajkow, these slag inclusions consist of manganous sulphide (MnS), and the examination of a large number of specimens of cast steel showed that slag is a normal structural constituent of the metal.

Theory of Equilibrium in the Iron-Carbon System.—A. Portevin† sums up the present state of the theory of equilibrium as applied to the iron-carbon system, and points out that few questions have attracted more research and discussion during the last twenty-five years than those presented by a study of iron-carbon alloys. He reproduces the diagram published by Roozeboom in 1900, with certain modifications based upon more recent researches. The arguments in favour of the existence of two systems are summarised thus: It has for a long time been recognised that prolonged anneal-

* *Engineering*, vol. lxxiv. p. 13.

† *Revue de Métallurgie*, vol. iv. pp. 993-1005.

ing of white pig iron (carbide system) at a temperature below 1000°C . yields free carbon, called temper carbon, which is distinguishable from graphite from early segregations by the size and shape of its plates. Below 1000°C . there is therefore a dissociation of cementite, and a tendency for carbon to assume the graphitic form, which is thus more stable. This fact, formerly observed by Forquignon, Saniter, Forster, and Schöne, has been demonstrated anew by the experiments of Wüst and of Sauveur. The rapid cooling of pig iron gives a white pig (carbide system), while slow cooling, which approximates more nearly to the establishment of equilibrium, gives grey pig (graphite system). Roozeboom himself was led to admit that rapid cooling diminished the percentage of graphite above 1000°C ., and had been obliged to consider the reaction on cooling—mixed crystals of graphite, passing to cementite—as always incomplete, even when the graphite and the mixed crystals were in intimate contact, as in the eutectic, while Osmond and Le Chatelier, whose observations were confirmed by Charpy and Grenet, had noticed that the line of saturation of the solid solution by graphite was wholly above the line of saturation of the solid solution by cementite. The latter condition of equilibrium was therefore instable, while Charpy and Grenet made further observations which absolutely invalidated the theory of the formation of cementite during cooling. Benedicks, commenting on the work of Troost and of others, had adduced, in further support of the two-system theory, the view that cementite, being endothermic, was therefore instable, but as Osmond has since found it to be exothermic, this argument cannot be employed. Nevertheless, the recorded facts show the stable form of equilibrium to be graphite, and that if, on surfusion, cementite is obtained, it tends constantly to decompose into graphite when the temperature is sufficiently high and the passive resistances not too great. It is indeed the latter which confer on cementite its appearance of stability at ordinary temperatures. The results observed with certain nickel-iron alloys are noted in this connection. The conditions of transformation from one system to another are thus considered, the case of a pure pig iron, exempt in particular from the influences of silicon and manganese, being specially dealt with. Later, the powerful effect induced by the presence of these elements is noted, and the various modifications to which they give rise described, together with the disturbances which arise under the influence of pressure.

Solubility of Graphite in Iron.—G. Charpy* refers to previous investigations bearing on the solubility of graphite in pig iron, and seeks to ascertain the actual coefficient of solubility. Such a determination presents great difficulties, principally in the case of iron not containing silicon, on account of the extreme slowness with which solution of the graphite takes place and combined carbon becomes converted into graphite. Four modes of investigation were employed.

* *Revue de Métallurgie*, vol. v. pp. 77-78.

The first was the solution of graphite—previously separated by cooling—in solid iron; the second method was the separation of graphite by annealing white pig iron; and the third, the slow cooling of the molten pig iron. The last method employed consisted of cementing iron in various mediums. The results are given for each series of experiments, the conclusion being drawn that the solubility of graphite decreases regularly with the temperature, and may be regarded as equivalent, at 1000° C., to 1 per cent. in the case of pure iron.

G. Charpy* has prepared a grey iron by melting a Swedish iron cemented by wood charcoal, slowly cooled, which contained 3.75 per cent. total carbon, 3.34 per cent. being graphite, and less than 0.1 per cent. of silicon and manganese. Upon heating for six to seven hours when below 900°, and for three hours at higher temperatures, and then quenching, the percentages of combined carbon were as follows:—

Annealing temperature . . .	750°	850°	1000°	1050°	1080°	1100°	1150°
Percentage of combined carbon . .	0.31	0.85	1.08	1.36	1.44	1.40	2.47

A sample of white iron of the same composition, after being heated to 1150°, cooled slowly to 1000°, and quenched, contained 0.92 per cent. of combined carbon. A similar sample cooled slowly from fusion to 1000° and quenched contained 0.95 per cent. of combined carbon. Samples of iron cemented at 1000° in wood charcoal contained 1.10 and 0.89 per cent. of combined carbon respectively. From these results it is found that the solubility of graphite in iron increases regularly with the temperature, and that at 1000° the solubility is about 1 per cent.

Experiments on the solubility of graphite in iron are described by C. Benedicks.† The material used was a Swedish grey pig iron containing 3.9 per cent. of carbon, 0.75 per cent. of silicon, 0.37 per cent. of manganese, and very little phosphorus and sulphur. After heating for two to three hours at 650° C., the specimen was rapidly heated to 800°, and the temperature gradually reduced during a couple of hours. In this way an iron was obtained consisting only of graphite and ferrite. Experimenting with this material it was found that after a comparatively brief heating for an hour or two at about 940° C., the typical structural constituents of carbon steel (martensite, troostite, sorbite, and pearlite) were formed. This indicates a considerable solubility of graphite in iron at 940°, amounting to about 1 per cent., a fact in accordance with the older views as to the stable iron-carbon system, and not with the theories of Heyn and Ruer.

Graphite and Graphitic Carbon in Pig Iron.—G. Charpy ‡ has carried out certain experiments to establish the identity of ordinary

* *Comptes Rendus*, vol. cxlv. pp. 1277-1279.

† *Metallurgie*, vol. v. pp. 41-45.

‡ *Revue de Metallurgie*, vol. v. pp. 75-76.

graphite, and the graphitic carbon which separates on reheating and cooling white pig iron. Forquignon regarded the free carbon which separates from grey pig iron on slow cooling, and the free carbon which separates from white pig iron when it is heated to a sufficiently high temperature and cooled, as being distinct varieties, and this view has been corroborated by Ledebur. If the distinction hold good it would be necessary to modify Roozeboom's diagram by taking into consideration their variations. The chief claim to the contention that the graphite in these two forms is of a different nature arises from the statement made both by Forquignon and Ledebur as to the action of hydrogen and of nitrogen on the two forms. These gases are stated to gasify the graphitic carbon which separates on annealing when passed over the pig iron heated to redness, but to exert no influence on graphite. Recent researches by Wüst and Geiger on the other hand show these gases, when pure, to be without action on either forms, the gasification observed earlier being attributable to the presence of traces of oxygen. In order to settle the question, the author separated molten pig iron into two portions; one was cooled very slowly and solidified as white iron, and the other was cooled rapidly, and after being allowed to solidify as white iron was converted into grey iron by reheating. The latter contained traces of graphite only when first cooled, but after annealing 3.69 per cent. of carbon of annealing was present, while the iron cooled slowly (the first portion) contained 3.55 per cent. A certain amount of carbon was separated from both samples of pig iron by boiling nitric acid. Treated by Moissan's method, with potassium hydrate, the carbon was, in both instances, transformed into graphitic oxide, at the same rates of speed. The size of the crystals differed somewhat, but not more so than the size of the original grains would have led one to anticipate. The progressive decarburisation was subsequently noted by subjecting both pig irons to a current of carefully purified hydrogen, the temperature of the samples being maintained at 1000°. The results of these experiments led to the conclusion that both forms of graphite could be completely gasified under these conditions, and that they could both be regarded, conformably with the Roozeboom diagram, as forming a single phase in the iron-carbon system.

Influence of Phosphorus on Iron-Carbon Alloys.—According to F. Wüst,* the temperature at which saturated iron-carbon alloys begin to solidify is lowered by the addition of phosphorus, 1 per cent. of phosphorus causing a depression of 27°. When the proportion of phosphorus exceeds 6.7 per cent., the freezing point again rises. The ternary eutectic melts at 950°, and contains 6.7 per cent. phosphorus, 2.0 per cent. carbon, and 91.3 per cent. iron. The eutectic disappears at a phosphorus content of 15 per cent., corresponding with the phosphide Fe_3P . Alloys containing between 6.7 per cent. and 15 per cent. of phosphorus show crystals of the phosphide. The

* *Metallurgie*, vol. v. pp. 73-87.

solubility of carbon in iron is reduced by the addition of phosphorus, but the temperature of formation of the eutectoid pearlite is not influenced by the presence of the phosphide.

Manganese-Iron Alloys.—L. Guillet* gives the results of a chemical and metallographical examination of a long series of white cast irons containing increasing proportions (0·86 to 42·22 per cent.) of manganese. He finds that γ -iron is present in cast irons containing high percentages of manganese.

Iron-Molybdenum Alloys.—Lautsch and G. Tammann † give the temperature-concentration diagram from 0 to 70 per cent. of molybdenum. At 42·5 per cent. of molybdenum a compound of iron and molybdenum is formed, which does not attain equilibrium, the behaviour being as in a ternary system consisting of iron, molybdenum, and an independent element. When the alloys are made by the aluminothermic method, the temperature reaches 2300°, and the presence of the compound is well marked, but the formula is not established.

Copper-Iron Alloys.—R. Sahmen ‡ finds that copper and iron are completely miscible in the fused state, and that there are two series of mixed crystals, from 0 to 3·5 per cent. and from 97·3 to 100 per cent. by weight of copper respectively. The results of thermal and magnetic observations are given.

Iron-Aluminium Alloys.—A. G. C. Gwyer § gives particulars of iron-aluminium alloys.

Tantalum Steel.—L. Guillet || gives an account of his investigation of the properties of tantalum steel.

The Rusting of Iron.—A summary has been published ¶ of recent investigations of the rusting of iron.

L. M. Stern ** discusses the preservation of iron and steel by paint. The porosity of paint, and the false economy of using cheaper paint on metal in exposed exterior conditions, where appearance is not regarded, is condemned. Most of the metal-preserving paints are of mineral origin. Carbon pigments show far superior resistance to the accumulation of rust when the oils begin to wear out, or become eliminated, after long exposure, than do oxygen pigments, nor are they much affected by acids either in a liquid or a gaseous form. Of carbon pigments graphite is to be preferred. The nature of the oils

* *Comptes Rendus*, vol. cxlvi. pp. 74-75.

† *Zeitschrift für anorganische Chemie*, vol. lv. pp. 386-401.

‡ *Ibid.*, vol. lvii. pp. 1-83.

§ *Ibid.*, vol. lvi. p. 113.

|| *Comptes Rendus*, vol. cxlv. p. 827.

¶ *Engineering*, vol. lxxxv. pp. 329-331.

** *Iron Age*, vol. lxxx. pp. 1466-1470.

or fats used as vehicles for the paint is then discussed, with special reference to the behaviour of linnoxyn, the compound of linseed oil and oxygen which forms as the result of the so-called drying of the oil. The use of soluble solids, such as varnishes, tar, pitch, and asphaltum, is also considered. Paint-dryers should be avoided. They mostly consist of rosin, and impair the stability of the paints into which they are introduced. A correct diagnosis of the conditions of the exposure to which the paint is subjected is, however, the most important point. This should take into consideration extraordinary exposure to heat or cold, to liquids, abrasion, &c. Hints for testing pigments and for precautions in specifying the nature and quality of the preservative coatings are also given.

A. Schleicher* and G. Schultz have studied the voltage set up between clean and rusty strips of wrought iron and cast iron when immersed in water not connected electrically. The results are tabulated in a series of curves. With a rusty and clean wrought iron plate, the latter was found to act as the cathode, iron being dissolved. With a couple consisting of a clean wrought-iron and a cast-iron plate, the latter formed the cathode.

The protection of water-mains from rust is discussed by H. Wehner.†

Corrosion of Iron and Steel.—An investigation of the effect of coal gas on the corrosion of wrought iron pipe buried in the earth is described by W. L. Dudley.‡

In a lengthy paper on the corrosion of steel, A. S. Cushman§ refers to the peculiar action of chromic acid and its salts. Polished specimens of steel may be kept indefinitely without suffering corrosion when immersed in a dilute solution of potassium bichromate. On first thought it would seem a paradox that a strong oxidising agent should have the effect of preventing the oxidation of iron, and yet this is the case. According to the author's theory the oxidising agent polarises the surface of the iron to the condition of an oxygen electrode, so that it is immune from the attack of the hydrogen ions; thus the whole electrolytic process is checked or inhibited. A curious feature of this action is, that it is to a certain degree persistent after the metal has been removed from contact with the oxidising solution, washed and wiped. This phase of the phenomenon requires further study, but at the present time it does not appear probable that the induced passive condition can be maintained on the surface to an extent that would make it of practical value for treating structural steel. With regard to the preservation of boiler tubes, and for certain special purposes, it is not unlikely that a practical application of these principles will be found.

* *Stahl und Eisen*, vol. xxviii, pp. 50-53.

† *Gesundheits-Ingenieur*, 1907, p. 245.

‡ *Journal of the American Chemical Society*, vol. xxx, pp. 247-250.

§ *Journal of the Franklin Institute*, vol. clxv, pp. 111-120.

Precipitation of Iron from Pyrites.—H. Ditz* describes experiments on the precipitation of iron from iron pyrites by means of aluminium powder.

Impure Nickel Plate.—D. F. Calhane† and A. L. Gammage state that the small quantities of iron in nickel plates form with the nickel a series of galvanic couples, and after long exposure to the atmosphere cause rusting of the plate. As commercially practised an anode of nickel and iron is suspended in a bath of nickel-ammonium sulphate, and the iron is deposited with the nickel. The iron deposited increases if the electrolyte is agitated, or if the electrodes are rotated. By surrounding the anodes with a suitable filtering medium, the amount of impurity in the form of iron was reduced about one-half. The presence of iron in the nickel plate is probably due to primary deposition, and with the anodes at present used, it seems impossible to avoid small amounts of iron in nickel plate.

The Early Metallurgy of Tungsten.—P. Nicolardot‡ discusses the early metallurgy of tungsten and its applications in commerce. It was first obtained in a pure state by Juan and Fausto d'Elhuyar, two Spaniards who had been pupils of Bergman. They isolated it in the year 1784, and subsequently prepared a number of alloys with antimony, lead, gold, copper, manganese, platinum, iron, silver, and bismuth. In 1785 Raspe repeated the investigations of the d'Elhuyar brothers, and noticed its tendency to harden iron and steel, which he conceived capable of being put to account in practice. Berthier in 1834 prepared samples of ferro-tungsten, all of which were brittle. There are reasons for suspecting that tungsten was the metal employed by Bréant, the Assay-Master of the Paris Mint, for hardening his dies and to produce damascened steel. He wrote a memoir, which was given an award in 1817 by the Société d'Encouragement, but never published. The close connection which exists between damascening and the effect of tungsten was established in 1844 by the Duc de Luynes, who, after analysing samples of the celebrated Wootz steel, obtained perfectly damascened samples of steel by heating iron nails in a mixture of wolfram and sawdust, although the Duke subsequently attributed damascening solely to the action of manganese. The progressive stages of the metallurgy of tungsten are then traced, the experiments of Percy, and the investigations of Koeller and Sperl, in Vienna, and the later experiments at Brest and at Terre Noire being described up to the time of present day investigators, amongst whom Hadfield, White, Taylor, Osmond, Guillet, and Böhler are specially mentioned, the work of Hadfield being in particular cited as a valuable source of information for those interested in the metallurgy and applications of tungsten and its alloys.

* *Metallurgie*, vol. iv. pp. 786-792.

† *Journal of the American Chemical Society*, vol. xxix. pp. 1268-1274.

‡ *Revue de Métallurgie*, vol. v. pp. 9-23.

CHEMICAL ANALYSIS.

CONTENTS.

	PAGE		PAGE
I. Analysis of Iron and Steel . . .	412	III. Analysis of Fuel	417
II. Analysis of Iron Ores and Slag . .	416	IV. Analysis of Gas	418

I.—ANALYSIS OF IRON AND STEEL.

Ironworks Analysis.—G. Gallo * gives a summary of methods for the determination of the various constituents of iron and steel, and appends a bibliography of the subject.

The methods of analysing the raw materials and products at the Midland blast-furnace, Ontario, are described by G. D. Drummond.†

K. Friedrich ‡ describes some new types of electrically heated laboratory furnaces.

Determination of Carbon.—B. Neumann § describes the more recent advances in the direct combustion of the carbon in steel and iron alloys so as to determine it without previous isolation. The Shimer and Eimer crucibles, which are largely used in America for this purpose, are described and illustrated.

L. L. de Koninck ¶ and E. von Winiwarter propose the burning of the iron with lead borate in a current of oxygen, and the estimation of the carbon dioxide formed by any suitable means.

The determination of carbon in pig iron and steel is described by M. Orthey.**

Determination of Manganese.—E. W. Mayer †† describes modified forms of the Volhard method of determining manganese in iron and steel as employed at the Witkowitz ironworks. Of the

* *Rassegna Mineraria*, vol. xxvi. pp. 165-168, 184-186, 200-203, 216-218, 235-237. 248-250.

† *Journal of the Canadian Mining Institute*, vol. x. pp. 442-465.

‡ *Metallurgie*, vol. iv. pp. 778-781.

§ *Stahl und Eisen*, vol. xxviii. pp. 128-131.

¶ *Bulletin de la Société chimique de Belgique*, vol. xxii. pp. 104-105; *Journal of the Chemical Society*, vol. xciv. pp. 320-321.

** *Chemiker Zeitung*, vol. xxxii. pp. 31-33.

†† *Zeitschrift für angewandte Chemie*, vol. xx. pp. 1980-1981.

four modifications described, the following two are the most suitable for technical purposes: (1) 1 gramme of ferro-manganese, 4 grammes of pig iron, or 8 grammes of steel are dissolved in nitric acid (to 1.2); the solution is evaporated to a small bulk, diluted with water, introduced into a litre flask, and mixed with a sufficiency of zinc oxide emulsion to precipitate the iron. The whole is then diluted to 1 litre, and in 250 cubic centimetres of the filtrate the manganese is titrated with standard permanganate. (2) The sample is dissolved as before in nitric acid, but before boiling down a few drops of hydrochloric acid are added.

L. Sacerdoti* describes a modification of Deshay's volumetric method of estimating manganese in steel.

E. Raymond † again recommends a process published by him in 1883, based on the fact that manganese is precipitated as dioxide when its solution in nitric acid is heated with potassium chlorate. The dioxide is then estimated by dissolving it in an acid solution of ferrous ammonium sulphate and titrating the excess of the latter with standard permanganate.

Determination of Phosphorus.—M. Frank ‡ and F. W. Hinrichsen have investigated the causes of the discrepancies which occur between different chemists' results of the proportion of phosphorus in steel. Estimations made with and without special precautions to remove arsenic are recorded, and these show that a very large percentage of the arsenic is precipitated with the phosphate precipitate by the molybdate process and estimated as phosphorus. They show that in pure solutions of arsenic acid this precipitation does not occur, the presence of phosphoric acid being apparently necessary to drag the arsenic down with it.

Some sources of Error in the Determination of Phosphorus.

—It was pointed out in 1895 by Carnot that certain sources of error were present in the ordinary molybdate method for determining phosphorus. G. Chesneau § has investigated these. He finds that 50 cubic centimetres of molybdate solution (75 grammes of ammonium molybdate to the litre) is only sufficient for 1 to 2 grammes, and not for 5 grammes of sample. This enormous excess of the precipitant is necessary because the ammonium molybdenum phosphate is soluble in iron salts. The complete precipitation is only obtainable in presence of an excess of molybdic acid and ammonium salts. For washing the precipitate the author finds pure water better than either weak ammonia or ammonium nitrate solutions. The conditions under which molybdic acid tends to come down with the precipitate are investigated, and the author finds that

* *L'Industria Chimica*, vol. vii. pp. 258-259.

† *Bulletin de la Société chimique de Belgique*, vol. xxii. pp. 75-80.

‡ *Stahl und Eisen*, vol. xxviii. pp. 295-298.

§ *Comptes Rendus*, vol. cxlv. pp. 720-722.

the precipitation must take place at very moderate temperature, as other investigators have found.

Determination of Chromium.—G. Gallo* describes the methods of analysis to be adopted with irons and steels containing high percentages of chromium.

A. Caffin † and F. Dhuique-Mayer describe a method for determining chromium in ferrochrome with high-carbon content. Fusion with sodium peroxide gives satisfactory results.

Determination of Nickel.—E. Pozzi-Escot ‡ describes the determination of nickel in the presence of cobalt, iron, and manganese.

E. Pozzi-Escot § deals with new characteristic reactions of nickel. The reaction employed to determine nickel in the presence of cobalt depends upon the insolubility of nickel in a weak acid solution in the presence of an excess of alkaline molybdate. In order to carry out the reaction the sulphides of nickel and cobalt are dissolved in aqua regia, the solution is displaced with ammonium nearly to saturation, and then displaced with a saturated solution of ammonium molybdate. The solution is then stirred and heated to 60° to 70°. The solution colours red in the presence of cobalt, in the presence of nickel a greenish white crystalline precipitate originates. This reaction allows the detection of very small quantities of nickel in the presence of larger quantities of cobalt. The nickel precipitated as molybdate has a crystalline structure, and appears under the microscope in the form of well-formed small square glittering leaves. To carry out this micro-chemical reaction a few drops of the solution to be examined are concentrated on an object-glass, a drop of the molybdate solution is added and heated to 60°. If crystals are not formed immediately, dissolve in a drop of water and again heat. On cooling, even in the presence of only traces of nickel, the characteristic crystals are formed. The only care to be observed is that the solution shall not be too acid.

A volumetric method for the determination of nickel is described by H. Cantoni || and M. Rosenstein.

O. Brunck ¶ has investigated the estimation of nickel in iron and iron alloys, which is known to be a tedious determination for iron-works chemists. The usual separation of the iron by ammonia, although convenient, is well known to be inexact. In two test cases on a 4.15 per cent. nickel steel, the author obtained 78 per cent. and 76 per cent. of the nickel only. Brunck has shown ** that

* *Atti della Reale Accademia dei Lincei*, vol. xvi., Part I., pp. 58–67.

† *Moniteur Scientifique*, vol. xxii. pp. 88–91; *Chemisches Zentralblatt*, 1908, No. I. pp. 988–987; *Journal of the Chemical Society*, vol. xciv. p. 538.

‡ *Comptes Rendus*, vol. cxlv. p. 1334.

§ *Annales de Chimie analytique*, vol. xii. pp. 393–395.

|| *Bulletin de la Société Chimique*, 1908, pp. 1163–1169.

¶ *Stahl und Eisen*, vol. xxviii. pp. 331–333.

** *Zeitschrift für angewandte Chemie*, vol. xx. pp. 1844–1850.

in dimethylglyoxin we have a body which is capable of precipitating nickel from its solutions as a red precipitate, crystalline in character, from dilute neutral solutions. This precipitant enables one to separate nickel from iron, chromium, zinc, manganese, and cobalt. The precipitate is easily filtered and washed, and when dried at 110° to 120° C. possesses the composition $C_8H_{14}N_4O_4Ni$, and contains 20.31 per cent. of nickel. Full details of working the process in the presence of iron are given, and the test analyses given are exceedingly satisfactory.

An expeditious titration method* consists in adding to the solution containing the nickel, potassium iodide and some silver solution, and titrating with potassium cyanide until the turbidity produced by the iodide of silver has disappeared. Details of the method have been published by C. M. Johnson.†

Determination of Titanium.—A colorimetric method of determining small proportions of titanium in iron ores is described by J. H. Walton.‡

The colorimetric determination of titanium in the presence of iron is described by P. Faber.§

Determination of Nitrogen in Iron.—N. Tschischewski|| has contributed a paper on this subject. He describes his method of estimating the combined nitrogen by distillation and subsequent iodometric estimation, or by Nesslerising. Comparative figures of the results obtained by the two methods are given; the titration methods for samples low in nitrogen proving itself the best. Owing to the formation of amine organic compounds low results are obtained by the colorimetric comparison of the distillate against ammonium chloride standards. The author suggests that the influence of titanium in fixing and neutralising the effects of nitrogen in steel should be studied.

Petrén and Grabe have described two methods for the estimation of nitrogen in steel, the one colorimetric, the other iodometric. The former is carried out by distilling the solution of the iron dissolved in hydrochloric acid with purified caustic soda solution, and Nesslerising in the ordinary way. The iodometric method also depends on distilling over the ammonia. To the distillate there is added 5 cubic centimetres of a $\frac{1}{20}$ normal sulphuric acid solution, a small fragment of iodine, and a few cubic centimetres of a 4 per cent. solution of a potassium iodate solution. The free iodine is titrated after the addition of a little starch by this $\frac{1}{20}$ sulphate solution in the usual way.

* *Stahl und Eisen*, vol. xxviii. p. 370.

† *Journal of the American Chemical Society*, vol. xxix. pp. 1201-1208.

‡ *Ibid.*, pp. 481-485.

§ *Chemiker Zeitung*, vol. xxxi. pp. 263-265.

|| *Stahl und Eisen*, vol. xxviii. pp. 397-399.

II.—ANALYSIS OF IRON ORES AND SLAG.

Determination of Iron.—R. Mauzelius* suggests that oxidation during grinding constitutes a large and hitherto unsuspected source of error in the determination of ferrous iron in rocks and minerals.

Nicholas Knight† states that when assaying native ferrous carbonate, such as siderite, by the Berzelius-Bunsen process of separating the ferric from the ferrous iron by means of barium carbonate, it is of great importance that the mineral should be merely coarsely powdered. If reduced to a fine state of division, a not inconsiderable portion of the ferrous iron is oxidised to the ferric state; this is due in part to the heat generated by the friction, and also to the larger surface exposed.

According to Wilhelm Strecker‡ ferric hydroxide is precipitated completely on addition of ammonia to a solution containing 0.1110 gramme of iron in the ferric state and 0.1911 gramme of tartaric acid in 53 cubic centimetres. If a larger proportion of tartaric acid is present, the precipitation is incomplete, and is finally inhibited. Attempts to isolate a complex compound from the resulting red solution containing excess of tartaric acid have been unsuccessful, as the products obtained do not have a constant composition.

G. Magri§ and G. Ercolini describe a method for separating iron from aluminium and titanium.

Determination of Phosphoric Acid.—C. H. Ketner|| describes the determination of total phosphoric acid in basic slags by Grete's method of titration with gelatin-molybdenum solution until no further precipitate is formed.

Determination of Silica.—L. G. Eakins¶ also gives a method for the determination of insoluble matter.

H. C. Parmelee** points out that the term insoluble siliceous residue is exceedingly vague. He proposes defining it as that portion of a mineral substance remaining insoluble after treatment by hydrochloric and nitric acids, subsequent evaporation to dryness, filtration, washing and ignition of the residues. He gives a standard method for carrying out the above operations.

G. W. Dean†† describes the determination of silica and alumina in iron ores.

* *Sveriges Geologiska Undersökning, Afhandlingar*, 1907, No. 3.

† *Chemical News*, vol. xcvi. p. 122.

‡ *Chemiker Zeitung*, vol. xxxi. p. 1217.

§ *Gazzetta chimica italiana*, vol. xxxvii. p. 179.

|| *Chemisch Weekblad*, vol. iv. pp. 759-764; *Journal of the Chemical Society*, vol. xciv. p. 64.

¶ *Western Chemist and Metallurgist*, vol. iii. pp. 120-121.

** *Ibid.*, pp. 115-117.

†† *Journal of the American Chemical Society*, vol. xxix. pp. 1208-1210.

Determination of Magnesia.—Josef Mayrhofer* describes a citric-acid method for directly determining magnesia in magnesites.

C. Catlett † gives a method for the estimation of magnesia in limestone. The sample is ground to a standard size, measured in a measuring spoon, treated with a measured volume of dilute hydrochloric acid, filled up to 10 cubic centimetres in a test-tube, and the carbon dioxide expelled by boiling. In another test-tube a cold saturated solution of sugar is mixed with one of potassium hydrate, and similarly diluted to the 10 cubic centimetre mark. The contents of the first test-tube are now filled into the second, containing the alkaline sugar solution, when, if magnesia be present, it will be precipitated at the line of contact of the two solutions, which are subsequently mixed, while practice enables a rough approximation of its amount to be made from observations of the density of the precipitate.

III.—ANALYSIS OF FUEL.

Coal Analysis.—A detailed account has been published by N. W. Lord ‡ of the experimental work conducted in the chemical laboratory of the United States fuel-testing plant, St. Louis, between January 1, 1905, and July 31, 1906. Interesting results have been obtained in the determination of specific gravities of coal, in laboratory methods of determining the adaptability of coals to improvement by washing, and in the estimation of volatile matter in coals and lignites. It is shown that the value obtained for volatile matter in coal is affected by the method of heating the sample, by the fineness of pulverisation, and by the amount of loosely held moisture present.

Heinrich Trachsler§ describes the Federal testing laboratory for fuels in Zurich. The establishment comprises a machine shop, Millot crusher, Peugeot mill, Millot rolls, cohesion machines, room for drying samples of coal, workshops, room with four calorimeters to determine the heat of combustion by the Langbein method, room for determining ash, coke, and extracts, weighing room, and a small calorimeter room with two calorimeters. On the first floor, chemical laboratory, elementary laboratory, gas room with Junker calorimeter. The samples of coal are tested in the following manner: (1) Determination of moisture; (2) determination of ash; (3) determination of volatile matter; (4) determination of the calorific value; (5) determination of the percentage of carbon, hydrogen, oxygen, nitrogen, sulphur, the composition of the ash and the specific gravity; and (6) determination of the strength of coal briquettes.

* *Zeitschrift für angewandte Chemie*, vol. xxi. pp. 592-593.

† *Bi-monthly Bulletin of the American Institute of Mining Engineers*, 1907, pp. 947-951.

‡ *United States Geological Survey, Bulletin No. 323*.

§ *Zentralblatt für Eisenhüttenwesen*, vol. ii. p. 630.

Determination of Moisture.—The best methods of determining the moisture and hygroscopicity of lignite are discussed by G. B. Frankforter.*

Determination of Volatile Matter.—A. Bement † describes some experiments carried out with the object of determining the amount of volatile matter in coal. The powdered fuel in the crucible was protected from loss by oxidation during heating by passing hydrogen over it to form a non-oxidising atmosphere.

Petroleum Analysis.—L. Singer ‡ proposes a scheme for standardising the methods of analysing mineral oils.

IV.—ANALYSIS OF GAS.

Apparatus for Gas Analysis.—The apparatus for gas analysis used for the accurate analysis of coal-gas, producer-gas, blast-furnace gas, and exhaust-gas in the investigations for the third report to the Gas-engine Research Committee is described by F. W. Burstall.§ He describes a modified form of the Huntley apparatus for analysing gases. It differs very considerably from those ordinarily employed, as the gas is always measured at constant volume and pressure. The essential feature consists of a glass vessel having a capacity of 100 cubic metres. This vessel is entirely water-jacketed, the outer jacket being provided with delicate thermometers so as to measure the temperature of the gas with great exactitude. Water is kept circulating through the jacket at approximately the temperature of the room, as, if water from the mains be used, dew is apt to form on the outside of the vessel, which renders it very difficult to make accurate observations. Near the base of the inner glass vessel there is a black glass finger having a fine rounded point, and the inner vessel communicates by a capillary tube through a T-piece with both the barometer column and movable vessel which is filled with mercury. The barometer column, which has a length of about 1 metre, is provided at its top with a large globe fitted with a stop-cock, which can be sealed with mercury and arranged so as to measure the partial pressure of any gas contained in the inner vessel. The movable mercury reservoir is adjusted so that the mercury just touches the black glass point, and this can be done with extreme accuracy, for if the mercury is lifted too high the point becomes immersed, and if too low the reflection of the point can be seen readily in the mercury surface below. When the level in the inside of the gas-reservoir has

* *Journal of the American Chemical Society*, vol. xxix. pp. 1488-1496.

† *Chemical Engineer*, September 1907.

‡ *Chemische Revue*, vol. xv. p. 1.

§ *Proceedings of the Institution of Mechanical Engineers*, January 17, 1906 (advance proof).

been correctly adjusted, the height of the mercury column in the barometer tube can be read to one-tenth of a millimetre.

An accurate form of gas-analysis apparatus adapted for the analysis of producer-gas is described by W. A. Bone* and R. V. Wheeler.

Methods of Gas Analysis.—A. Dosch † discusses the indirect determination of unburnt gases in the products of combustion. The combustion is found to be complete by the analysis of the products of combustion if no unconsumed gases are present, and the correct amount of air has been employed. In practice a complete analysis of the gases is onerous, and therefore the combustion is judged by the determination of carbonic acid and oxygen. According to an empirical rule the sum of CO_2 and O, if the combustion is complete, is approximately 20 per cent. of the total volume of the gases of combustion. According to the experiments of the author the quantity, in addition to the kind of coal, depends on the excess of air. For coal it varies between 18.7 to 20.4 per cent, according to whether it is burnt with the theoretical or with three times the quantity of air. To determine from the analysis of CO_2 and O the presence of unburnt gases the kind of coal, whether anthracite coal or brown-coal is employed as fuel. From practical experiments the value of CO_2 found must correspond to a definite percentage of O if the combustion is complete. As an example, if the percentage of CO_2 in the gases of combustion of a coal is found to be 11.5 per cent., then the sum of CO_2 and O must amount to 19.25, therefore the percentage of O is 8.15 per cent. If the percentage of oxygen found by analysis differs considerably from the calculated amount, then the presence of considerable quantities of unburnt gases can be admitted with certainty.

E. Barnhart ‡ describes a rapid and accurate method of gas analysis.

Information regarding technical gas analysis is furnished by J. Pfeifer.§

F. Häusser || describes the method of testing the waste gases from a suction-producer for unburnt constituents.

A new method of analysing combustible gases is described by G. de Voldere ¶ and W. de Smet.

Automatic Gas Analysis.—A new apparatus for indicating the proportion of carbon dioxide, the coometer, is described.**

* *Journal of the Society of Chemical Industry*, vol. xxvii. pp. 10-11.

† *Giesserei Zeitung*, vol. iv. pp. 628-632.

‡ *Electrochemical and Metallurgical Industry*, vol. v. pp. 350-352.

§ *Zeitschrift des Bayerischen Revisions-Vereins*, 1907, pp. 239-241, 253-255.

|| *Verhandlungen des Vereins zur Beförderung des Gewerbflusses*, 1907, pp. 437-441.

¶ *Revue générale de chimie pure et appliquée*, vol. x. p. 253.

** *Iron Age*, vol. lxxxi. pp. 27-28.

L. Fabre* describes the apparatus generally employed for the analysis of gases and automatic apparatus which enables the progress of combustion to be controlled continuously. The determination of carbonic acid in waste gases is of the greatest importance.

Victor Samter † gives an account of methods and apparatus for rapid and continuous gas analyses.

* *Revue générale de chimie pure et appliquée*, vol. x. No. 20.

† *Zeitschrift für angewandte Chemie*, vol. xx. pp. 1851-1852.

STATISTICS.

CONTENTS.

	PAGE		PAGE
I. United Kingdom	421	XIII. Natal	435
II. Australasia	423	XIV. Norway	435
III. Austria-Hungary	424	XV. Orange River Colony	436
IV. Belgium	425	XVI. Roumania	436
V. Bulgaria	425	XVII. Russia	436
VI. Canada	425	XVIII. Servia	437
VII. China	426	XIX. Spain	437
VIII. France	429	XX. Sweden	438
IX. Germany	431	XXI. Transvaal Colony	439
X. Greece	434	XXII. Turkey	439
X†. India	434	XXIII. United States	439
XII. Japan	435	XXIV. Comparative Tables	444

I.—UNITED KINGDOM.

Mineral Statistics.—According to official statistics * the coal production of the United Kingdom in 1907 amounted to 267,830,962 tons, which is an increase of 16,763,334 tons on that of the previous year. The production of iron ore in 1907 was 15,731,604 tons as compared with 15,500,406 tons in 1906. There were 16,098 tons of manganese ore produced during the year, a falling off as compared with the 22,762 tons produced in 1906. Other minerals included 2,546,522 tons of oil shale, 6654 tons of bauxite, and 271 tons of wolfram.

Iron Trade Statistics.—The British Iron Trade Association returns † show that the production of pig iron in the United Kingdom during the year 1907 was 9,923,856 tons, as compared with a production of 10,149,388 tons in 1906. The pig iron produced is classified as follows:—

	Tons.
Forge and foundry	4,512,985
Hæmatite	3,776,797
Basic	1,406,038
Spiegel, ferro-silicon, &c.	223,036
Total	9,923,856

* *Mines and Quarries: General Report and Statistics for 1907.* Part I. p. 10.

† *Iron and Coal Trades Review*, vol. lxxvi. pp. 1294, 1489, and 1779.

The average number of furnaces in blast was 366½, and the average annual output per furnace, 27,096 tons of pig iron.

The production of open-hearth steel during 1907 was 4,663,489 tons as compared with 4,554,936 tons in 1906. The production of acid and basic open-hearth steel respectively was as follows:—

	Tons.
Acid open-hearth steel ingots	3,384,780
Basic open-hearth steel ingots	1,278,709

The different descriptions of open-hearth steel finished products are classified as follows:—

	Tons.
Steel bars and tinplate bars	950,938
Blooms and billets	580,961
Steel rails	79,532
Structural shapes	266,821

There were 392 open-hearth furnaces in operation during the year, and the average production of steel per furnace was 11,098 tons of acid steel, and 14,698 tons of basic steel.

The production of Bessemer steel ingots during 1907 amounted to 1,859,259 tons, as compared with 1,907,338 tons in 1906. These figures do not include the output of small and special converters used in Sheffield, the output of which is estimated not to exceed 30,000 tons during the year. The production of acid and basic Bessemer steel respectively was as follows:—

	Tons.
Acid Bessemer steel ingots	1,230,315
Basic Bessemer steel ingots	578,944

The production of Bessemer steel rails in 1907 was 832,576 tons, as compared with 854,740 tons in 1906. There were 44 acid and 23 basic converters in operation, on an average, during the year.

The output of puddled iron in 1907 in the United Kingdom, so far as returns are available, 975,083 tons, which was a decrease of 35,263 tons on the output of the previous year, but an increase of 36,525 tons on that of 1905. The number of puddling furnaces in operation was 1202.

T. Good* discusses the future of the iron and steel industry in Great Britain.

Combination and competition in the steel trade is discussed by T. Good.†

The report of the Departmental Committee on Checkweighing in the iron and steel trades has been issued as a Parliamentary paper.‡

Iron Ore.—According to the forty-fifth annual report of C. E. Müller & Company, Limited, the production of Cleveland ore in

* *Cassier's Magazine*, vol. xxxiii. pp. 372-376.

† *Engineering Magazine*, vol. xxxiv. pp. 241-249.

‡ [Cd. 3846.]

1906 was 6,102,223 tons, the production during 1907 being estimated at 6,220,000 tons. In 1907, 7,638,934 tons of iron and manganese ores were imported into Great Britain, of which 5,712,490 tons came from Spain. 109,459 tons of manganese ores were imported at Tees ports during 1907.

Accidents in Mines and Quarries.—According to the official returns * the number of fatal accidents and deaths in and about mines and quarries in the United Kingdom during the year was heavier than during 1906. The number of fatal accidents at all mines under the Coal Mines Act in 1907 was 1162, compared with 1065 in the previous year, and the number of deaths was 1245, compared with 1142 in 1906.

Shipbuilding.—Returns collected from various districts † show that the output of new shipping from British yards in 1907 aggregated 1,814,722 tons, as compared with 2,002,571 tons in 1906, a reduction of 187,849 tons. The total included 37,200 tons of naval shipbuilding, as against 47,100 in the previous year. To this total English yards contributed 1,001,246 tons, Scottish yards 674,934 tons, and Irish yards 138,542 tons.

Exhibitions.—For organising the iron and steel section of the Franco-British Exhibition, London, 1908, a committee was formed with Sir Hugh Bell, Bart., President of the Iron and Steel Institute, as chairman, and as members E. Windsor Richards and E. P. Martin, Past-Presidents of the Iron and Steel Institute; Sir J. G. N. Alleyne, Bart., Sir W. T. Lewis, Bart., K.C.V.O., W. Beardmore, and Arthur Cooper, Vice-Presidents; G. Ainsworth, C. J. Bagley, David Colville, J. H. Darby, W. H. Hewlett, J. E. Stead, F.R.S., J. M. While, and Illyd Williams, Members of Council; H. Bauerman, hon. member, and Bennett H. Brough, Hon. Secretary. The Exhibition was opened on May 14, and its general character is described in the technical journals of that week. Details of the structural features have also been published.‡

The Scottish National Exhibition§ at Edinburgh was opened on May 1, as was also the Hungarian Exhibition at Earl's Court, London.

II.—AUSTRALASIA.

Ironmaking in New South Wales.—A short account of the present position of the iron industry in Australia has appeared.||

* *Mines and Quarries: General Report and Statistics for 1907.* Part I. pp. 22-23.

† *Iron and Coal Trades Review*, vol. lxxvii. pp. 50-51.

‡ *Engineer*, vol. civ. pp. 548-550; *Engineering*, vol. lxxxiv. pp. 736-739.

§ *Engineer*, vol. cv. p. 460.

|| *Stahl und Eisen*, vol. xxvii. p. 1639.

Until recently the manufacture of iron was only carried on intermittently, owing to market difficulties. The works at Lithgow, near Sydney, are described.

Mineral Statistics of New Zealand.—The mineral production of New Zealand in 1906 included 16 tons of manganese ores, 141,641 tons of coal (exported), and 5 tons of coke. The consumption of coal was 1,587,895 tons.

Mineral Statistics of South Australia.—The production of iron ore in South Australia in 1906 amounted to 33,852 tons, and that of limestone to 4791 tons.*

According to official statistics † the production of tungsten ore in Northern Territory of South Australia in 1906 amounted to 102 tons, valued at £6981, as against 63 tons in 1905.

III.—AUSTRIA-HUNGARY.

Mineral Statistics of Austria.—The production of coal in Austria in 1907 was 13,828,438 tons, and that of brown-coal 26,148,073 tons.‡

Mineral Statistics of Hungary.—A. Wahlner§ has published his report on the Hungarian mineral statistics for 1906. The total value of the mineral production was 118,411,187 crowns, the highest figure hitherto reached. The principal share of the total value is taken by brown-coal, of which the value was 38,626,005 crowns. The total mining and metallurgical production included, in metric tons: brown-coal, 6,307,184; coal, 1,026,056; briquettes, 151,656; coke, 79,922; forge pig iron, 402,527; foundry pig iron, 17,164; manganese ore, 10,894; iron ore, 1,698,290; and crude asphalt, 34,664.

The Hungarian pig iron production in 1906 was 419,691 tons. The number of workpeople engaged in Hungarian mines and works (excluding salt mines) was 72,290, of which 65,683 were men, 1673 women, and 4934 children. In the mines and works in 1906 there were 348 serious accidents and 109 fatal accidents.

A description has been published|| of the steel works of Resicza, the iron works of Anina, the mechanical engineering works of Vienna, all belonging to the Privileged Austro-Hungarian State Railway Company. The two first works have an annual capacity of 135,000 tons of pig iron, 100,000 tons of rolled materials, 110,000 tons of coke, whilst the mines now worked turn out 200,000 tons of

* *Board of Trade Journal*, vol. lix. p. 223.

† *Ibid.*, p. 528.

‡ *Montan Zeitung*, vol. xv. p. 48.

§ *Bányászati és Kohászati Lapok*, vol. xl. pp. 706-870.

|| *Engineer*, vol. civ. pp. 499-501.

iron ore and the collieries send up 420,000 tons of coal. The parent works at Vienna produces chiefly locomotives, their capacity for these being 140 heavy engines per year.

P. Martell * gives a statistical account of the Hungarian iron industry. According to the latest census there were, in 1905, 49 ironworks, employing 24,270 workpeople. The production of pig iron in that year was 397,400 tons. The number of ironworks and iron and steel foundries had risen in 1906 to 57, employing 25,456 workpeople. Details of the production at various works and of the imports and exports of iron and steel are given.

IV.—BELGIUM.

Mineral Statistics.—G. Baum † gives an account of the mining and metallurgical industries of Belgium.

The production of coal in Belgium ‡ in 1907 amounted to 23,824,499 metric tons, as compared with 23,610,740 tons in 1906.

Iron Trade Statistics.—Returns of the output of pig iron in Belgium show § that during the year 1907 there were 37 furnaces in blast out of 42, and that they produced 1,427,640 of pig iron, or 1640 tons less than in 1906. The production was made up as follows:—

	Tons.
Forge pig iron	226,130
Foundry pig iron	100,020
Pig iron for steel production	1,101,490
Total	1,427,640

V.—BULGARIA.

Mining Law.—A translation of the mining law of Bulgaria of January 16, 1906, has been published.||

VI.—CANADA.

Mineral Statistics.—The revised mineral statistics of Canada for 1905 have been issued by E. D. Ingall.¶ The total production is valued at £13,905,034, the most valuable product being coal, which

* *Giesserei Zeitung*, vol. v. pp. 85-88.

† *Zeitschrift für das Berg-, Hütten- und Salinenwesen*, vol. lv. pp. 547-574.

‡ *Annales des Mines de Belgique*, vol. xiii. p. 385.

§ *Bulletin de la Comité des Forges*, No. 2743.

|| *Mining Journal*, vol. lxxxii. pp. 539-540, 570.

¶ *Geological Survey of Canada*, Report No. 971.

accounts for 25.2 per cent. of the whole. The coal production was 8,667,948 tons. The production of iron ore was 117,000 tons, and that of pig iron, from Canadian ore, 68,170 tons. There was also produced 18,876,315 lbs. of nickel ore, 240,000 lbs. of cobalt ore, 1584 tons of fireclay, 541 tons of graphite, 309,405 tons of limestone for flux, 22 tons of manganese ore, 634,095 barrels of petroleum and natural gas valued at £75,912.

The preliminary official report prepared by J. M'Leish * on the mineral production of Canada in 1907 shows that the exports of iron ore amounted to 25,901 tons, the make of pig iron from Canadian ore to 107,599 tons, and the production of nickel to 21,189,793 lbs. There were also produced 105,961 tons of coal, 50 tons of peat, 579 tons of graphite, 748,581 dollars' worth of natural gas, 788,872 barrels of petroleum.

The official mineral statistics given by T. W. Gibson † show that the production of Ontario in 1906 included 275,558 tons of pig iron, 10,936 tons of nickel, 1772 tons of graphite, 300 tons of peat fuel, 19,928,322 gallons of petroleum, and 533,446 dollars' worth of natural gas.

During 1906, 18,331 tons of bog iron ore were, according to H. M. Lamb, ‡ produced in the province of Quebec, the production of chrome iron ore, during the same period, being 9961 tons.

The possibilities of iron ore mining in the province of Quebec are discussed by F. Cirkel. § If capital were to undertake the utilisation of the iron ore resources by the employment of modern methods of concentration, it might expect a rich reward.

Iron Trade Statistics.—According to statistics collected by J. M. Swank, || the total production of pig iron in Canada in 1907 amounted to 581,146 tons. The production of basic pig iron amounted to 341,257 tons, and the production of Bessemer pig iron to 154,910 tons.

VII.—CHINA.

Mineral Statistics.—A report on the foreign trade of China, written by Sir A. Hosie, ¶ contains much information regarding mining. The output of the Chinese Engineering and Mining Company's three mines in the K'ai-p'ing district to the north-east of Tientsin amounted in 1906 to 958,675 tons, against 851,523 tons in 1905. The mining operations of the Peking Syndicate, which promised so well at first, seem to have been very unfortunate. The

* Ottawa: Government Printing Bureau, 1908.

† *Annual Report of the Bureau of Mines*, Toronto, vol. xvi. p. 4.

‡ *Engineering and Mining Journal*, vol. lxxxiv. pp. 1160-1161.

§ *Journal of the Canadian Mining Institute*, vol. x. pp. 108-117.

|| *Bulletin of the American Iron and Steel Association*, vol. xiii. p. 12.

¶ *Engineering*, vol. lxxxiv. pp. 878-879.

mine at Pai-shan, in the province of Honan, had been flooded after a 14-foot seam of coal had been pierced, and it had been found necessary to send for increased pumping plant from the United Kingdom. It has been found, however, that the seam struck was too friable to work, and at a still greater depth another seam, 10 feet in thickness, has been reached, and a fair quantity of good workable coal is now being raised daily. At the Fang-tzu mines in the province of Shantung, the Shantung Mining Company produced 163,233 tons of coal during 1906, against 134,000 tons in 1905, and of that 23,000 tons were exported. In connection with this mine a washing plant and a briquette factory have been inaugurated.

The last coal-mine referred to in the report is that being worked by the Kiangpei Coal and Iron-Mining Company in the province of Ssuchuan. Much time has been lost in making preliminary agreements, but a large mine not far from the port of Chung King, which was already being worked by a British pioneer in conjunction with Chinese, has been secured by the company, and there is every hope that the output of this coal—one of the best in China—will be largely increased.

Iron Industry.—C. Blauel, formerly engineer to the Hanyang Iron and Steel Works, situated near the city of Hankow, upon the junction of the Han and Yangste rivers, has given an interesting description of these works.* The published description is accompanied by a map of the locality and several general views of the works. As the author points out, the fact that during last year several cargoes of pig iron were sent to the United States from the interior of China, which were sold in competition with the known American brands, is a reason for examining carefully into this new Chinese industry. The pig iron so sent had to pay an import duty of almost 17 shillings per ton, and in addition had to bear the expenses of a river journey of some 600 miles, and a sea voyage of some 6600 miles, or almost half round the globe.

The Hanyang Works are situated some 750 miles from the coast. They were commenced in 1891 by the newly appointed governor of the province of Hupeh, Chang-Chi-tung, under the supervision of English engineers. The works consisted of two blast-furnaces, each with two Cowper stoves, with a daily production of about 50 tons per furnace, twenty puddling furnaces arranged in groups of four, two Bessemer converters each of 5 tons capacity, one 12-ton basic open-hearth furnace, a reversing-mill for rails, blowers, &c., and a small mill for sheets. The works were some five or six years building, and some eighty Chinese were sent over to Belgium to study the various processes. The blast-furnace plant started with one furnace in 1894; the daily capacity per furnace has been increased up to 70 or 100 tons, according to the quality of pig iron made. The puddling furnaces were only worked for a short time.

* *Stahl und Eisen*, vol. xxviii. pp. 1-8.

The converter plant is fed by cupola melted iron, and has been at work since the end of the nineties, chiefly on rails for the Hankow-Peking Railway, which was built between 1900 and 1905. The converter plant and also the open-hearth plant (which works with some 30 per cent. pig iron in the charge) supply material to the sheet mills. The yearly output of the rolling-mills has hitherto been from 15,000 to 20,000 tons, and often considerably less. Owing to various causes the works, in 1904, passed almost entirely into the hands of the railway director, Sheng-Kung-Pao. It was then decided to erect a modern open-hearth furnace plant, in order to be able to utilise all the native ores, some of which are phosphoric. The following analyses of iron ores from the Tayeh district, some sixty miles south of Hankow, and which are chiefly red oxides and magnetite, will show the average composition of the ore available :—

Iron	58 to 68 per cent.
Silica	3 „ 7 „
Alumina	1 „ 2 „
Manganese	0.2 „ 0.4 „
Phosphorus	0.04 „ 0.25 „
Sulphur	0.05 „ 0.1 „
Copper	0.05 „ 0.25 „

A brown ironstone containing 6 to 9 per cent. of manganese is also found. The deposit of the two chief ores is estimated at 100,000,000 tons, and occupies a mountain range some seven to eight miles long. An immense deposit of almost pure carbonate of lime is also present. The ore deposit is connected by a railway, some fifteen miles in length and of normal gauge, with a shipping station on the Yangtse river. From there the ore is shipped to the works in lighters drawn by steam tugs, the distance being about seventy miles. Ore for Japan is shipped direct into steamers from the same station. The coke formerly used has lately been superseded by coke from the Ping-hsiang mines, which contains about 12 to 15 per cent. of ash, and 0.8 per cent. of sulphur. The coke from these mines is now made in sufficient quantity to supply all the requirements of the blast-furnaces. The pits are situated some 250 miles from the works, the fuel being brought by water-carriage.

The works were modernised in 1904 to 1906 by the erection of three open-hearth furnaces, each of 30 tons capacity, a gas-heated mixer of 150 tons capacity, with producer plant, casting cranes, ingot casting cars, locomotives, &c. There was also put in three large reversing rolling-mills with electrically-driven live roller plant for cogging ingots, rolling heavy plates up to 2.5 metres wide, and for rolling rails and joists, with all modern accessories. A third blast-furnace for a production of 300 tons of pig iron daily was ordered from Germany at the beginning of 1907, the blast being heated by four Cowper stoves, with electric plant, turbo-blower, locomotives, slag ladles, &c. The fourth and fifth open-hearth furnace, with a second mixer, is to be erected, together with a fourth blast-furnace, also of 300 tons daily production, for which the founda-

tions are already in. The old Bessemer plant and the puddled iron works have been dismantled. The work of erecting the new plant has been done by Chinese under the supervision of European engineers.

The author gives details of the wages paid for the various classes of labour. Speaking generally, he thinks it is difficult to give a trustworthy opinion of the future of the Hanyang Iron and Steel Works, although to-day the prospects are brighter than ever before in their history. For the year 1908, unless unforeseen difficulties occur, the output should reach 40,000 to 50,000 tons, and when the third blast-furnace is finished at the end of this year, up to 100,000 tons. The present general manager of the works is V. K. Lee, who has spent many years in Europe and Japan. The technical departmental managers are all Europeans.

The long and typically hot summers of the mid Yangtse Valley render it difficult for foreigners to remain long as a rule. The temperature of the air often remains for weeks together, day and night, from 86° to 104° F. In July and August it is often too hot for the Chinese to work, so that hitherto the works have ceased operations then, but this it is hoped in future to obviate with the improvements in the plant. Although the region of the middle and upper Yangtse has not been fully explored for its mineral deposits, it is known to contain mineral deposits of gold, silver, copper, zinc, lead, and antimony, and in addition large deposits of iron ore and coal.

Deposits of rich iron ore are known to occur in the provinces of Kweichow and Kiangsu; brown ironstone, high in manganese (about 20 per cent. manganese) is found in large quantities at Poyang-see, about 150 miles from Hankow, and a rich manganese in the neighbourhood of Ping-hsing (40 per cent. manganese). If, in addition to the Yangtse deposits, the rich iron ore deposits in Shantung, Hunan, Kuangtung, and Kuangsi are taken into consideration, and also those in Tongking, which belongs to France, it is probable that the iron ore deposits of China are not much less than those of the United States. Whilst not perhaps equally abundant, coal suitable for coke-making occurs in considerable quantity.

The conditions in the Yangtse Valley are most favourable for the development of the iron industry, especially on account of the shipping facilities to the coast. The author mentions, in conclusion, other iron-making projects which have from time to time been started in China, such as those at Shanghai, Hanyang, Fouchou, and Tientsin.

VIII.—FRANCE.

Mineral Statistics.—The coal production of France in 1907 amounted to 36,168,386 tons, in addition to 761,861 tons of brown-coal.

Detailed statistics have been prepared * of the mineral production of France and of Algeria during the year 1906. The production of iron ore during that year was 8,481,000 tons, of which 7,821,000 tons was got from mines, and 660,000 from quarries. This marks an increase of 14 per cent. on the production in 1905. The bulk of the production was oolitic iron ore, of which 7,443,000 tons were extracted; brown hæmatite amounted to 359,000 tons, and red hæmatite to 264,000 tons. Particulars of the oolitic iron ore areas in the Meurthe-et-Moselle are given. The production of manganese ore was 11,189 tons. The iron trade statistics for the year are given in full.

E. Reumaux † reviews the present condition of the coal-mining industry of France.

Iron Trade Statistics.—The production of pig iron in France in 1907 was 3,588,949 tons, as compared with 3,314,162 tons in 1906, showing an increase of 274,788 tons last year. The production of each district was as follows:—

	Metric Tons.
Meurthe-et-Moselle	2,499,004
Nord	465,682
Centre and West	201,581
Loire and South	172,968
South-West	130,098
Aveyron and Ariège	71,552
Champagne-Comte	48,074
	<hr/>
	3,588,949

The official returns ‡ of the production of pig iron in France during 1907 show that 121 furnaces were in blast during the year out of 142. Nine new blast-furnaces were under construction. There were produced from these furnaces 3,588,949 tons of pig iron, as compared with 3,314,100 tons in 1906. The production was made up as follows:—

	Tons.
Forge pig iron	112,467
Foundry pig iron	539,233
Refined iron	673,886
Bessemer pig iron	122,046
Basic pig iron	1,968,343
Non-manganiferous pig iron	107,720
Spiegel, ferro-manganese, &c.	27,273
Various brands	17,982

The production of steel in France during the year 1907 has been returned § as 2,677,805 tons, which is an increase of 10 per cent. of the production during the previous year, which was 2,240,284 tons,

* *Statistique de l'Industrie Minérale et des Appareils de Vapeur en France et en Algérie: Bulletin de la Comité des Forges*, No. 2739.

† *Mémoires de la Société des Ingénieurs Civils de France*, vol. lxi. pp. 15–29.

‡ *Bulletin de la Comité des Forges*, No. 2749.

§ *Ibid.*, No. 2751.

and an increase of 20 per cent. as compared with 1905. The steel produced is classified as follows:—

	Production in Tons.
Basic Bessemer steel	1,630,511
Acid Bessemer steel	77,421
Open-hearth steel	955,555
Crucible steel and steel produced in electric furnaces	14,318
	2,677,805

The production of blooms was 982,170 tons, and of billets, 538,104 tons. The principal finished products were as follows:—

	Tons.
Rails	297,762
Girders	107,488
Sections	717,916
Sheets and plates	352,042

The number of workmen employed at the blast-furnaces was about 14,000.*

The French iron industry is reviewed by H. Konrad.†

The iron industry of the northern French Ardennes is described by P. Dunaine.‡

IX.—GERMANY.

Mineral Statistics.—Preliminary official statistics § show that in 1907 Germany and Luxemburg produced 143,168,301 tons of coal, 62,559,364 tons of brown-coal, 27,697,127 tons of iron ore, 12,875,159 tons of pig iron, and 2,517,389 tons of cast iron.

With *Glückauf*, 1908, No. 11, a pamphlet of 60 pages is issued as a supplement. It gives the production of every mine in the Dortmund district in 1907. The production of the district for the years 1903 to 1907 is reviewed by E. Jüngst.||

From the report of the Rhenish Westphalian Coal Syndicate ¶ for 1907, it appears that the number of working days were: for coal, 300 $\frac{1}{2}$ in 1907, against 300 in 1906; whilst the output per day was 266,631 tons in 1907, against 255,438 tons in 1906. The figures for the year were 80,156,000 tons in 1907, against 76,631,000 tons in 1906; and the total sale amounted to 80,147,000 tons in 1907, against 76,581,000 tons in 1906. Of coke, the total production was 15,535,446 tons in 1907, against 14,294,692 tons in 1906. The manufacture of briquettes amounted to 2,860,105 tons in 1907, against 2,532,207 tons in 1906.

* *Bulletin de la Comité des Forges*, No. 2749.

† *Eisen-Zeitung*, vol. xxviii, pp. 796-797, 815-816, 850-851.

‡ *Annales des Mines*, vol. xiii, pp. 5-107.

§ *Verein Deutscher Eisen und Stahl Industrieller*, 1908, No. 4.

|| *Glückauf*, vol. xlv, pp. 386-396.

¶ *Ibid.*, pp. 355-359.

An elaborate series of charts dealing with the average prices of coking coal, coke, and various iron ores, pig iron, steel, ingots, blowers, slabs, sections, plates, &c., made in Germany for the period from 1885 to the end of 1907, has been published.* Tables and notes of the amounts imported and exported to and from different countries from 1903 to 1907 are given, together with comparative productions in Germany, Great Britain, and the United States.

A. Kaysser † draws attention to the extent to which Germany is now dependent on foreign countries for her iron and manganese ore requirements, and urges the importance of opening out more of her own native ore deposits.

The imports of iron ore into Germany in 1907 were 26 per cent. more than in 1906, whilst the pig iron production was only 4½ per cent. more. The consumption of foreign ore thus shows a tendency to increase. Sweden takes the first place with 42·5 per cent. of the total imports, whilst Spain furnished only 25·3 per cent.‡

Iron Trade Statistics.—The production of pig iron in Germany in 1907 is stated§ to have been 13,045,760 tons. Of this total 17·31 per cent. consisted of foundry iron, 3·61 per cent. of Bessemer pig iron, 65·11 per cent. of basic pig iron, 7·93 per cent. of steel-making pig and spiegeleisen, and 6·02 per cent. of forge pig iron.

In 1907 the 102 steelworks in Germany produced 12,063,632 tons of steel, of which 685,161 tons was acid, and 11,378,471 tons basic.||

Mineral Statistics of Prussia.—The mineral statistics of Prussia for 1906 have been published,¶ with details of progress made at the individual mines. The total production of coal was 128,295,948 tons, 61·36 per cent. of which was produced in the Ruhr coalfield, and 23·12 per cent. in Upper Silesia. The output for the kingdom was 274 tons per miner, for the Ruhr 276 tons, and for Upper Silesia 323 tons. The total production of brown-coal was 47,912,721 tons, being 1011 tons per miner employed. The iron ore production, which amounted to 4,713,928 tons, included, in tons, brown iron ore, 1,451,637; clay ironstone, 37,488; spathic iron ore, 2,277,728; coal measure ironstone, 8699; red hæmatite, 798,559; magnetic, 32,781; pisolitic iron ore, 96,635; bog iron ore, 5682; clay and brown iron ore, 515; and sphaerosiderite, 4204.

Details of the financial results of the operations of the Prussian government mines and works in 1906 have been published. The government has control of twenty-one collieries, six brown-coal mines, two iron mines, five metal mines, and five salt mines, making thirty-nine mines in all. It also controls five ironworks, seven

* *Stahl und Eisen*, vol. xxviii. pp. 217-218, and Charts III. to V.

† *Ibid.*, pp. 210-211.

‡ *Zeitschrift für angewandte Chemie*, vol. xxi. p. 802.

§ *Frankfurter Zeitung*, January 24, 1908; *Board of Trade Journal*, vol. lx. p. 240.

|| *Verein Deutscher Eisen- und Stahl Industrieller*, 1908, No. 6.

¶ *Zeitschrift für das Berg-, Hütten- und Salinenwesen*, vol. lv. pp. 71-196.

smelting-works, five salt-works, four mineral springs, three quarries, one amber mine, and one deep boring. The surplus on the year's working was £1,372,242, or £160,337 less than in 1905, but £137,117 more than the estimates. The number of men employed in the government mines and works was 89,130.

K. Hilgenstock * compares the wages paid in British and Rhenish-Westphalian collieries.

L. Aguillon † gives some notes on the new Prussian mining law of June 18, 1907.

Mineral Production of Saxony.—In 1906 ‡ the mineral production of Saxony included, in metric tons, coal, 4,812,846; brown-coal, 2,314,147; tungsten ore, 52; iron ore, 3183; and fluorspar, 2361. Altogether 31,781 miners were employed, 25,298 in collieries, 3863 in brown-coal mines, and 2620 in metal mines.

Metallurgical Education.—J. E. Barnitzke § describes the new regulations for mining instruction at Berlin and Clausthal. For entering for the diploma examination there is required evidence of good preliminary education, one year's practical work at a mine, and four years' academic studies.

Z. Birnbaum || traces the historical development of the Berlin School of Mines.

The German Museum at Munich.—A general review of machines and appliances for the foundry and ironworks in the historical museum of science and technology at Munich is given. ¶ The article contains many very interesting illustrations, for instance, a wooden pattern of a furnace door of the Rötten Hütte from the year 1827, the original of a drawing press moulding machine for grenades, the first moulding machine with turning plate, the model of the first gear wheel moulding machine by Hofmann, and of a modern turntable machine, a model of the oldest German open-hearth steelworks, of the first German Bessemer plant, of the first pig iron mixer and other plant.

Bavarian Workmen's Museum.—A. Gradenwitz ** gives an illustrated description of the Royal Bavarian Workmen's Museum at Munich. It is one of the most important museums devoted to industrial hygiene in Germany, where the cause of industrial betterment has been largely furthered by such institutions. The museum is intended to further any efforts made in the field of workmen's protection, while affording a comprehensive view of present achieve-

* *Glückauf*, vol. xliii. pp. 1625-1639, 1677-1681, 1705-1717.

† *Annales des Mines*, vol. xii. pp. 217-241.

‡ *Jahrbuch für das Berg- und Hüttenwesen im Königreiche Sachsen*, 1907, p. 66.

§ *Glückauf*, vol. xlv. pp. 193-196.

|| *Die deutsche Hochschule*, 1908, pp. 342-344.

¶ *Gläsererei Zeitung*, vol. iv. pp. 15-20, 547-549.

** *Engineering Magazine*, vol. xxxiv. pp. 443-455.

ments in the prevention of accidents, in industrial hygiene, sanitary habitation, and alimentation.

Provident Funds.—The statistics of the mining provident funds in Prussia in 1906 have been published.* There were seventy-two such funds in operation. The number of participants was 695,507.

An interesting article on the German law in reference to provision against illness and the cure of the sick has been published by M. Böker,† with special reference to the working of these provisions at Remscheid.

An article on workmen's pension funds as carried on in Germany, and the legal position as to a man's right to any share in such funds on leaving a firm's employ, has been published.‡

X.—GREECE.

Mineral Statistics.—The official statistics for 1906 have been published.§ The production of iron ore amounted to 680,620 metric tons; manganese iron ore, 96,382 metric tons; manganese ore, 10,040 metric tons; chrome, 11,530 metric tons; magnesite, 64,424 metric tons; and lignite, 11,582 metric tons.

In 1906 Greece exported 397,000 tons of manganiferous iron ore, and 88,000 tons of red hæmatite.||

XI.—INDIA.

Mineral Statistics.—According to the report of T. H. Holland,¶ the mineral production of India in 1906 included 9,783,250 tons of coal, 140,553,122 gallons of petroleum, 495,730 tons of manganese ores, 2600 tons of graphite, 74,106 tons of iron ore, and 1832 tons of magnesite. The iron ore output is dominated by the quantity raised, 69,397 tons, for the Barakar ironworks. There was a considerable increase in the number of small native furnaces in the Central Provinces, the total being 379 against 279 in 1905.

Iron Ore in Mysore.—Official statistics** show that the production of iron ore in Mysore in 1905 was 1150 cwt., and that of iron 300 cwt.

* *Zeitschrift für das Berg-, Hütten- und Salinenwesen*, vol. lv. pp. 1-50.

† *Stahl und Eisen*, vol. xxviii. pp. 291-295.

‡ *Ibid.*, pp. 404-407.

§ *Board of Trade Journal*, vol. lix. p. 374.

¶ *Zeitschrift für angewandte Chemie*, vol. xxi. p. 322.

¶ *Records of the Geological Survey of India*, vol. xxxvi. pp. 63-108.

** *Report of the Chief Inspector of Mines of Mysore*, Madras, 1908.

XII.—*JAPAN.*

Mineral Statistics.—According to official returns, * the mineral production of Japan in 1907 included coal, 13,716,488 tons; peat, 63,550 tons; petroleum, 161,661 tons; pig iron, 11,610,995 kwamme; and steel, 1,223,023 kwamme (kwamme = 8·2817 lbs.).

An article has been published † discussing the financial position of the Imperial Japanese Steelworks. The chief difficulty is the lack of native iron ore. Coal is abundant, but the cost is high. During the ten years of their existence the Japanese Steelworks has cost the Japanese nation more than 56 million yen.

XIII.—*NATAL.*

Mineral Statistics.—According to the official report on the mining industry of Natal in 1906, the output of coal in the year was 1,238,713 tons, or an increase upon 1905 of 109,306 tons. Of the production 1,027,985 tons was round coal, 166,903 tons was nuts, and 43,825 tons was small coal. Of the twenty-four collieries producing, eighteen were in Klip River County, five in the New Territories, and one in Zululand, the respective districts giving 98·96 per cent., 0·04 per cent., and 1·00 per cent. of the total output, the corresponding figures for 1905 being 99·07 per cent., 0·09 per cent., and 0·84 per cent. Coke was made at the Natal Navigation colliery only, the amount produced being 307 tons. Of the coal output in 1906, 215,977 tons were exported from Durban by sea, 146,140 tons left the Colony overland, and 487,892 tons were supplied to vessels as bunkers. Though coal-cutters were first used in the Colony, as recently as 1901, 111 were at work for longer or shorter periods during last year, electrically-driven machines being used at the Elandslaagte, Dundee, and Central collieries, while compressed air was used as motive power at the Natal Navigation, Durban Navigation, South African, St. George's, Natal Cambrian, West Lennoxton and Glencoe collieries. The persons employed at collieries in 1906 numbered 6567, and the production per head of those employed underground was 307 tons.

XIV.—*NORWAY.*

Mineral Statistics.—According to official reports ‡ the production of iron ore in Norway in 1907 shows great progress as compared with 1906, when it amounted to 81,000 tons as against 130,000 tons last

* *Mining Journal*, vol. lxxxiii. p. 623.

† *Economist*, 1906, p. 551.

‡ *Mining Journal*, vol. lxxxiii. pp. 477-478.

year. Of this quantity 90,000 tons were exported in the form of ore, while 40,000 tons were treated by magnetic separation and briquetted. The total value is estimated at not far less than £100,000. The only furnace in operation for smelting iron ore is the Nás furnace at Tvedestrand.

XV.—ORANGE RIVER COLONY.

Mineral Statistics.—B. Adams * gives the coal production of the Orange River Colony during the year ending June 30, 1907, as 499,590 tons, as compared with 263,232 tons during the twelve months ending June 30, 1906. No new mines have been opened, and there is no immediate prospect of the output being much increased. Seventy-seven white men and 1334 coloured persons were employed at the collieries during the year.

XVI.—ROUMANIA.

Mineral Statistics.—C. Osiceanu † and T. Porucic give an account of the Roumanian mining industry in 1907.

The production of crude petroleum in Roumania in 1907 amounted to 1,130,000 tons or 27·5 per cent. more than in 1906. ‡

XVII.—RUSSIA.

Iron Trade Statistics.—Returns have been compiled § showing the production of pig iron in Russia during the years 1903, 1904, 1905, 1906, and for the first three months of 1907. The production of pig iron in 1906 was 2,642,000 tons, and for the first six months of 1907, 1,374,000 tons were produced, which is at the rate of 1,748,000 tons per annum.

The exports of iron ore from Russia increased from 471,175 tons in 1906 to 899,350 tons in 1907. In the latter year 369,400 tons went to Great Britain, 328,300 tons to Germany, 128,475 tons to Holland, 52,700 to Austria-Hungary, 13,275 tons to France, 400 tons to Italy, and 6800 tons to the United States.||

Mineral Production of the Caucasus.—A short time ago there were published official statistics as to the mineral production of

* *Annual Report of the Orange River Colony Mines Department for the Statistical Year ending June 30, 1907.*

† *Journal du Pétrole*, vol. i. p. 223.

‡ *Glückauf*, vol. xliiv. pp. 279-280.

§ *Kontor Jéliezavodchnikoff: Bulletin de la Comité des Forges de France*, No. 2756.

|| *Nachrichten für Handel und Industrie*, 1908, No. 57; *Stahl und Eisen*, vol. xxviii. p. 784.

the Caucasus in 1906. According to these * the production in that year was: Coal, 37,000 tons; manganese ore, 810,000 tons; and mineral oil, 7,336,610 tons. The coal is of indifferent quality, and has only local importance. Manganese ore of very good quality is worked at Tchiatory, in the province of Kutais; at the mines it costs not more than about 6s. per ton, but transport conditions, especially on the small local railway, are so unsatisfactory that after a transport of not more than 105 miles, its value at Poti is increased to about 30s., and it has been much higher even than this in 1906.

XVIII.—SERVIA.

Mineral Statistics.—The mineral production of Servia in 1906 represented a value of 4,734,723 francs, of which brown-coal represented 966,873, coal 886,580, and lignite 200,500.†

XIX.—SPAIN.

Iron Trade Statistics.—The Director-General of Customs, at Madrid, has issued † a return of the output of iron ore and pig iron in Spain in 1906. The output of pig iron was 379,000 metric tons in 1906, as against 393,000 tons in the previous year. The average number of furnaces in blast was eighteen at fifteen different works, and the consumption of iron ore is set down at 788,000 tons. The Sociedad de Altos Hornos de Viscaya made 216,000 tons out of the total output, the only other large producers being the Sociedad San Francisco del Desierto, 25,000 tons; Sociedad Duro-Felguera, 39,000 tons; and the Société des Hauts Fourneaux de Malaga, 25,000 tons. The output of iron ore is given as follows:—

	1906.	1906.
	Tons.	Tons.
Exported	8,590,483	9,311,325
Consumption at ironworks	779,454	788,177
Consumption—other industries	45,000	45,000
Total	9,414,937	10,144,502

* *Iron and Coal Trades Review*, vol. lxxvi. p. 532.

† *Zeitschrift für angewandte Chemie*, vol. xxi. p. 228.

‡ *Glückauf*, vol. xliii. p. 1347.

XX.—*SWEDEN.*

Mineral Statistics.—Official statistics * show that in Sweden in 1906 there were 308 iron ore mines in operation, the output amounting to 4,502,597 tons, averaging 64 per cent. of iron. The production of coal, from fourteen pits, was 296,980 tons. The mineral production also included 2680 tons of manganese ore, and 37 tons of graphite. The number of workmen employed was 10,495 in iron ore mines, 2057 in coal-mines, and 16,152 in ironworks. The iron ores were concentrated at eighteen works, and 78,205 tons of iron ore briquettes were made. At the 103 ironworks 128 blast-furnaces were in operation, and 604,789 tons of pig iron were produced. There were in operation 1426 prime movers aggregating 69,846 horse-power. These included 770 water-wheels and turbines with 44,212 horse-power, 125 steam-engines and steam-turbines with 9464 horse-power, 525 electric motors with 15,710 horse-power, and 6 hot-air or other motors with 460 horse-power.

Carl Sahlin † gives statistics showing the development of the Swedish iron trade from 1902 to 1906. Of electric steel 208 tons were made in 1902, whilst in 1906 the total was 935 tons.

Otto Vogel ‡ has contributed an interesting account of the progress made in Swedish metallurgical industries in every direction during the reign of His Majesty Oscar II. Statistics of the iron ore raised during various periods; the progress made with the Gröndal briquetting process, blast-furnace and steel-making statistics and other interesting data are given. The progress made in Swedish metallurgical industries generally during the reign of Oscar II. has been greater than in any other period of Sweden's history.

Iron Trade Statistics.—In 1907 in Sweden there were in operation 109 blast-furnaces, 258 hearths, 17 Bessemer converters, and 54 open-hearth furnaces. The year's production comprised 603,400 tons of pig iron, 77,000 tons of Bessemer ingots, and 334,200 tons of open-hearth steel ingots. The exports included 129,800 tons of pig iron, 11,700 tons of castings, and 177,900 tons of bar iron.§

According to the forty-fifth annual report of C. E. Müller & Company, Ltd., the exports of iron ore from North and Central Sweden in 1907 amounted to 3,680,789 tons, of which 2,857,294 tons went to Germany, and the remainder, 609,441 tons, went to Great Britain, Belgium, and other countries.

* *Kommerskollegii Underdaniga Berättelse*, Stockholm, 1907.

† *Blad för Bergshantaringens Vänner*, vol. xii. pp. 89-112.

‡ *Stahl und Eisen*, vol. xxviii. pp. 310-314.

§ *Afärsvärlden*, vol. viii. p. 167.

XXI.—*TRANSVAAL COLONY.*

Mineral Statistics.—The report of the Transvaal Mines Department* for the year ending June 30, 1907, states that the output of coal in that colony during the period was 2,912,083 tons, as against 2,751,136 in the previous year. The production of magnesite during the period covered by the report amounted to 1040 tons, as against 253 tons in the previous year.

Iron and Steel.—Alfred Adair† advocates the establishment of furnaces in the Transvaal, and the following comparative costs are given to illustrate the great advantage of the Transvaal over Europe in ores, especially in the case of spiegel, ferro-manganese, and ferro-chrome: Hæmatite ores, home cost, 13s. for 45 per cent. ore c.i.f.; Transvaal, 2s. 6d. per ton for 65 per cent. on trucks, which would make the cost per ton of Transvaal 3s. 8d. against 29s. 5d. for European. The author considers that the cost of labour, superintendence, repairs, and stores, &c., given as 4s. per ton of pig iron in England, will be doubled in the Transvaal, and that 2s. per ton must be added for difference in cost of plant. He bases his suggestions on the condition that the minerals can be secured without royalties, and that the company owning the works must possess the minerals and also considerable capital to start with.

XXII.—*TURKEY.*

Mining Industry.—A report has been published‡ on mining in Turkey in 1906. Iron ore is abundant. The asphalt mines of Selenitza in 1906 produced 6000 metric tons, of which 4800 tons were exported. The capacity of the mine will be much increased by the extension of the tramways and the erection of new refining furnaces. About 320 men are employed, all of whom, including the minor officials, are natives. Wages are low, but the cost of production is nevertheless high, on account of the lack of easy means of transportation.

XXIII.—*UNITED STATES.*

Mineral Statistics.—The official statistics of the mineral production of the United States in 1906 have been published in a

* *Board of Trade Journal*, vol. lx. p. 292.

† *South African Mines; Times Engineering Supplement*, January 8, 1908.

‡ *Montan Zeitung*, vol. xv. pp. 258-260.

volume of 1307 pages, edited by D. T. Day * and E. W. Parker. Articles are contributed on iron ores, pig iron, and steel by E. C. Eckel, on manganese ores by E. C. Eckel, on bauxite by E. F. Burchard, on nickel by F. L. Hess, on chromic iron ore by A. J. Collier, on coal by E. W. Parker, on coke by E. W. Parker, on natural gas by B. Hill, on petroleum by W. T. Griswold, on asphalt by J. A. Taff, on graphite by G. O. Smith, on magnesite by C. G. Yale, and on peat by M. R. Campbell.

According to preliminary estimates published on January 4, 1908, † the coal output of the United States was 468,543,334 short tons, of which 383,480,070 tons were bituminous, and 85,063,264 tons anthracite. The ore production during the year was estimated as having been 52,418,755 tons, and the production of petroleum 165,877,906 barrels.

Iron Trade Statistics.—According to statistics collected by J. M. Swank, ‡ the total production of pig iron in the United States during 1907 was 25,781,361 tons. This amount was 1.9 per cent. greater than that of 1906, and would have been still larger but for a decrease of production in the last part of the year, which continued into January 1908, during which month the output was below that of any other month since January 1904.

F. Hobart § gives the production of pig iron in the United States during 1907 as 25,975,944 tons, which is the largest production in any one year, and 668,753 tons more than the output in 1906. The total is made up as follows:—

	Tons.
Foundry and forge pig iron	6,254,459
Bessemer pig iron	13,847,178
Basic pig iron	5,145,736
Charcoal pig iron	393,296
Spiegel and ferro	335,275
Total	25,975,944

The imports amounted to 482,940 tons, and the exports to 76,500 tons. The difference added to the production gives, without allowing for stocks on hand, which are assumed to differ but little from those on hand at the beginning of the year, an approximate consumption of 26,381,384 tons, which gives an average yearly consumption per person of 688 lbs.

The pig iron production of the United States during 1907 is elsewhere || estimated at 25,307,191 tons.

* *Mineral Resources of the United States*, Washington, 1907.

† *Engineering and Mining Journal*, vol. lxxxv. p. 7.

‡ *Bulletin of the American Iron and Steel Association*, vol. xlii. p. 12.

§ *Engineering and Mining Journal*, vol. lxxxv. pp. 26-30.

|| *Ibid.*, p. 1.

The Bessemer steel ingot production in the United States in 1907 was 11,668,000 tons, including castings, against 12,276,000 tons in 1906. The production of Bessemer steel rails in 1907 was 3,302,000 tons, as against 3,706,000 tons in 1906.

The annual report of the American Iron and Steel Association gives the total production in 1906 of all kinds of iron and steel, the figures being in tons of 2240 lbs., except those for nails:—

	1906. Tons.
Pig iron, including spiegeleisen and ferro-manganese.	25,307,191
Spiegeleisen, ferro-manganese, ferro-phosphorus, &c.	306,642
Bessemer steel ingots and castings	12,275,830
Open-hearth steel ingots and castings.	10,980,413
All kinds of steel ingots and castings	23,398,136
Structural shapes, not including plates	2,118,772
Plates and sheets, except nail plate	4,182,156
Iron and steel wire rods	1,871,614
All rolled iron and steel, except rails	15,610,581
Bessemer steel rails	3,791,459
All kinds of rails	3,977,887
All rolled iron and steel, including rails	19,588,468
Iron and steel cut nails, in kegs	1,189,239
Iron and steel wire nails, in kegs	11,486,647

In all rolled iron and steel products the increase was from 16,840,015 tons in 1905 to 19,588,468 tons in 1906, or over 16 per cent.

The pig-iron statistics are as follows:—

	1906. Tons.
Bessemer and low phosphorus	13,840,518
Basic (mineral fuel)	5,018,674
Forge pig iron	597,420
Foundry and high silicon	4,768,011
Malleable Bessemer	699,701
Spiegeleisen	244,980
Ferro-manganese	60,662
White mottled, &c.	}
Direct castings	77,225
Total	25,307,191

The figures given for Bessemer pig iron include low-phosphorus pig iron—that is, iron running below 0.4 per cent. in phosphorus. Pig iron containing from 0.04 to 0.10 per cent. of phosphorus is classified as Bessemer. The basic figures are confined strictly to pig iron made with mineral fuel, and do not include the small quantity of basic iron that is made with charcoal. A few thousand tons of castings direct from the blast-furnace are included in the totals for the last two items in the table.

The production of Bessemer and open-hearth steel castings in 1906 was 719,891 tons, of which 406,343 tons were acid and 313,548 tons basic castings, as compared with 320,381 tons and 206,159 tons, respectively, in 1905.

The increase in the production of steel castings in 1906 over 1905 was 212,838 tons, or over 37·9 per cent.

The output of open-hearth steel rails in 1906 was 186,413 tons, against 183,264 tons in 1905, 145,883 tons in 1904, and 45,054 tons in 1903. Alabama made over 84 per cent. of the open-hearth rails rolled in 1906, Pennsylvania, Georgia, and Colorado rolling the remainder. The total Bessemer rail production in 1906 was 3,791,459 tons, while 15 tons of iron rails were rolled. The total of all kinds of rails produced in 1906 was 3,977,887 tons.

The production of crucible steel in 1906 is given * as 127,513 tons, against 102,233 tons in 1905, an increase of 25,280 tons, or over 24·7 per cent. The direct castings produced in 1906, included above, amounted to 10,343 tons, against 5733 tons in 1905. The following table gives separately the production of crucible steel ingots and castings for the last five years:—

Years.	Ingots.	Castings.	Total.
	Tons.	Tons.	Tons.
1901	94,586	3,927	98,513
1902	107,817	4,955	112,772
1903	97,025	5,409	102,434
1904	79,063	4,308	83,391
1905	96,500	5,733	102,233
1906	117,170	10,343	127,513

The conditions and prospects in the American iron industry are described by E. C. Eckel.† He gives in diagram form the iron trade statistics for 1870 to 1907.

Iron Ore.—J. Birkinbine‡ discusses the ore supplies and the development of iron ore mining in the United States, in regions other than that of Lake Superior. In 1889, out of a total production of 14½ millions of tons of iron ore, nearly 7 millions, or 48 per cent. of the total, came from districts other than Lake Superior, whereas in 1906 only 20 per cent. of the total production was derived from such sources. The ores in question were brown hæmatite mined in Southern States, and constituting 88 per cent. of all brown hæmatites mined; red hæmatites, of which Alabama furnishes about 3,000,000 tons annually; magnetites from northern Atlantic States, and carbonates, of which small amounts are mined in Ohio. Large ore supplies await development in the Rocky Mountain district.

D. E. Woodbridge§ contributes a review of the operations in the Lake Superior iron ore region in 1907. The shipments were approxi-

* *Annual Report of the American Iron and Steel Association, 1907*, p. 58.

† *Engineering Magazine*, vol. xxxiv. pp. 881-890.

‡ *Iron Trade Review*, vol. xlii. pp. 100-102.

§ *Engineering and Mining Journal*, vol. lxxxv. pp. 113-115.

mately 42,000,000 tons, making 379,663,414 tons since this source of supply was first tapped in 1855. The Mesabi range contributed 65·5 per cent. of the total production during the year, there being twelve mines on the range producing over a million tons each, of which two, the Hull-Rust and Morris, produced over 2,000,000, the actual output of the former having been 2,900,684 tons. More than half the production of the year, or 22,360,334 tons, were shipments of the Steel Corporation.

The supplies and reserves of iron ores are discussed by John Birkinbine.*

C. K. Leith,† in a paper on iron ore reserves, submits data to show that there seems to be little cause for alarm that North America will really suffer from lack of iron ore for a considerably longer period than that required for the exhaustion of the present known tonnage as estimated by Törnebohm and others, at the present rate of increase of production.

Coal.—According to E. W. Parker,‡ the total production of coal in the United States in 1906 amounted to 369,783,284 tons, of which 306,138,274 tons were bituminous and lignite, and 63,645,010 tons were Pennsylvania anthracite. One of the notable features presented by the statistics of bituminous coal production in the United States in 1906 was the increase in the use of machines, and in the quantity of machine-mined coal. The total quantity produced by the use of machines in 1906 amounted to 118,847,527 tons as against 103,396,452 tons in 1905. The number of machines in use increased from 9184 in 1905 to 10,212 in 1906. The percentage of machine-mined tonnage to the total production in the States in which machines are used has increased steadily each year, from 23 in 1899 to 35·1 in 1906. Of the total number of machines in use in 1906, 58 per cent. were of the pick or puncher type; 40·5 per cent. were chain breast machines, and 1·5 per cent. were longwall machines.

Statistics of coal production in the United States for 1885 to 1906 are given by G. Baum,§ who discusses America's position in the coal industry of the world.

Attention is directed by Clarence Hall|| and W. O. Snelling to the waste of life in American coal-mining. Four recent mine disasters in the United States, with the loss of nearly one thousand lives, emphasise the urgent importance of the theme. Statistics show in regard to deaths per million tons of coal that the United States not only occupies a position worse than European countries, but also exhibits a general increase in the rate, whereas every other country has shown a decrease. The situation is still worse when it is considered that the natural conditions in America for raising coal with the minimum

* *Journal of the Canadian Mining Institute*, vol. x. pp. 134-148.

† *Annual Report of the Smithsonian Institution*, pp. 207-214. Washington, 1907.

‡ *Mineral Resources of the United States*, 1907, p. 564.

§ *Gilchkauf*, vol. xlv. pp. 379-385.

|| *United States Geological Survey, Bulletin No. 333; Engineering Magazine*, vol. xxxiv. pp. 721-734.

amount of danger to the workmen employed are as favourable as in any other country in the world. The natural result of the working of the thinner and less favourably mined seams will be greatly to increase the death-rate unless regulations based on careful investigations are rigidly enforced.

Coke.—The production of coke in the United States during 1907 has been estimated * at 40,090,670 tons as against 36,040,000 tons in 1906. Pennsylvania still heads the list of States-producing coke, having made 26,243,205 tons in 1907, or eight times as much as any other State in the Union.

Petroleum.—The progress of the petroleum industry of the United States is discussed and statistics of production are given by H. C. George † and E. Haworth, and H. F. Bain.

Refractory Materials.—The production of graphite in the United States in 1906 included 5,887,982 lbs. of crystalline graphite, 16,853 tons of amorphous graphite, and 5,074,757 lbs. of artificial graphite. ‡ The production of limestone § for blast-furnace purposes during 1906 amounted to 16,077,202 tons, of which the bulk was obtained from Pennsylvania, Ohio, West Virginia, and Alabama, the first-named State alone producing 41.62 per cent. of the total. Of crude magnesite there was produced || 7805 tons, most of which was calcined, yielding 2864 tons, and a new deposit near Cloverdale, Sonoma County, has been opened up. The supply from home workings was, however, supplemented by no less than 141,314,682 lbs. of calcined magnesite, and 39,477,766 lbs. of crude magnesite, the amount received from the Vienna consular district alone having amounted to 53,000 tons. The production of bauxite ¶ during the year amounted to 75,332 tons, principally in Georgia, Alabama, and Texas. It contained, when washed, 56 to 58 per cent. of alumina and 8 per cent. of silica. Much of the production is used for making bricks for steel furnace linings, the percentage of silica being reduced by using a binder free from silica. 6,225,300 lbs. of carborundum ** were produced, and 4,712,000 lbs. of artificial carborundum, made at Niagara Falls from pure bauxite.

Jamestown Exhibition.—J. Struthers †† describes the mineral exhibits shown in the Department of Mines and Metallurgy at the Jamestown Exhibition, Virginia. Collections of ores, arranged by States, and special exhibits of the mineral resources of Virginia, were features of the Exhibition. Steel-hardening metals were also shown, and ferro-alloys, while one of the exhibits was a burglar-proof safe of manganese steel.

* *Engineering and Mining Journal*, vol. lxxxv. p. 80. † *Ibid.*, pp. 81-86.

‡ *Board of Trade Journal*, vol. lix. p. 375.

§ *Mineral Resources of the United States*. Washington, 1907, pp. 1034-1036.

|| *Ibid.*, pp. 1045-1046. ¶ *Ibid.*, pp. 501-505. ** *Ibid.*, pp. 1053-1054.

†† *Engineering and Mining Journal*, vol. lxxxiv. pp. 735-739.

XXIV.—COMPARATIVE TABLES.

The World's Production of Coal and Iron.—For purposes of comparison the following summary of the production of coal in the principal countries of the world is appended:—

Country.	Year.	Production in Tons.
United Kingdom	1907	267,830,962
Australasia—		
New South Wales	1907	8,657,924
New Zealand	1906	1,587,895
Queensland	1907	683,272
Tasmania	1907	58,891
Victoria	1906	160,631
Western Australia	1906	149,755
Austria, coal	1907	13,828,438
" lignite	1907	26,148,073
Hungary, coal	1906	1,026,056
" lignite	1906	6,307,184
Belgium	1907	23,824,499
Bosnia	1906	594,172
British Borneo	1906	62,974
Bulgaria	1906	133,205
Canada	1907	10,510,961
Cape Colony	1906	129,616
Chili	1905	793,927
China	1906	9,032,660
Corea	1906	5,896
Dutch East Indies	1906	389,006
Formosa	1905	85,348
France	1907	36,168,389
Germany, coal	1907	143,168,301
" lignite	1907	62,559,364
Greece, lignite	1906	11,582
Holland	1906	532,780
India	1906	9,783,250
Indo-China	1906	315,000
Italy, coal and lignite	1906	473,293
Japan	1907	13,716,488
Mexico	1906	700,000
Natal	1906	1,238,713
Orange River Colony	1907	499,590
Peru	1906	77,209
Portugal, anthracite	1906	6,762
Rhodesia	1906	94,168
Roumania, lignite	1905	130,331
Russia	1906	21,500,000
Servia	1906	272,241
Spain	1906	3,095,043
Sumatra	1906	277,097
Sweden	1906	296,980
Transvaal Colony	1907	2,912,083
Turkey	1905	450,000
United States	1907	428,973,251
Venezuela	1906	14,064

A similar summary showing the production of pig iron is as follows:—

Country.	Year.	Production in Tons.
United Kingdom	1907	9,923,856
Austria	1906	1,383,523
Hungary	1906	419,691
Belgium	1907	1,427,640
Bosnia	1907	48,923
Canada	1907	581,146
France	1907	3,588,949
Germany and Luxemburg	1907	13,045,760
Italy	1906	135,296
Japan	1906	42,679
Russia	1906	2,642,000
Spain	1906	379,241
Sweden	1906	604,789
United States	1907	25,781,361

A return has been prepared by the Commercial, Labour, and Statistical Department of the Board of Trade* showing the production and consumption of coal in the principal countries of the world during each of the years from 1885 to 1906. Particulars are also given as to the average value per ton at the collieries, the number of persons employed in coal-mining, coal imports and exports.

The World's Production of Iron Ore.—E. C. Eckel† gives the following as the latest obtainable figures for the iron ore production of the more important producing countries:—

	Tons.
United States	42,528,133
Germany and Luxemburg	23,444,073
Great Britain	14,590,703
Spain	9,077,245
France	7,395,400
Russia	6,050,000
Sweden	4,365,967
Austria-Hungary	3,697,679
Canada, Newfoundland	963,543
Cuba	561,159
Algeria	586,609
Greece	466,622
Italy	368,616
Belgium	178,620
China	123,000
India	102,120
Japan	100,000
Norway	46,582
Australasia	11,184
Portugal	8,200

The statistics given relate to the year 1905.

* No. 349. Coal Tables, 1906. (Price 6d.)

† *Mineral Resources of the United States*, p. 92. Washington, 1907.

Comparative Mineral Statistics.—The Home Office has issued a report* on statistics relating to persons employed, output and accidents at mines and quarries in the British colonies and foreign countries in 1906. The number of persons employed at home and abroad was 5,340,401, of which 1,908,980 were employed in the British Empire. The world's production of coal in 1906 is given as 1,013,644,524 tons, that of pig iron at 57,534,031 tons, and that of petroleum at 28,200,269 tons.

* Cd. 4145. Price 1s. 8d.

BIBLIOGRAPHY.

The following is a list of the principal works relating to iron and steel published during the first half of 1908 :—

METALLURGY.

AMERICAN IRON AND STEEL ASSOCIATION. "*Directory of the Iron and Steel Works of the United States.*" 17th edition, corrected to March 1, 1908. 8vo, pp. 500. Philadelphia.

[Embracing a full list of the blast-furnaces, rolling-mills, steelworks, bloomeries, and tin and terne plate works in the United States; also classified lists of wire rod-mills, rail mills, structural mills, plate, sheet, and skelp mills, and Bessemer, open-hearth, crucible, and steel casting works.]

"*Atti del Vi Congresso Internazionale di Chimica Applicata.*" Rome, April 26 to May 3, 1906. Edited by E. Paterno and V. Villavecchia. 7 vols. 4to, pp. 752+949+919+697+844+537+812. Rome: G. Bertero.

[The Official Report of the 5th Congress of Applied Chemistry held in Rome in 1906. Vol. II. contains papers on iron and steel by H. Wedding, F. Osmond, E. Saladin, Bennett H. Brough, L. Deslandes, G. Gin, and L. Gullet.]

BENDER, O. "*Feuerungwesen.*" 8vo, pp. 271, with 77 illustrations. Hanover: M. Jänecke. (Price 3s. 10d.)

BERINGER, J. J. "*Text-book of Assaying.*" 11th edition. 8vo, pp. 456, with 82 illustrations. London: Charles Griffin & Co., Ltd. (Price 10s. 6d.)
[Iron assaying is dealt with in chapter xi.]

BORCHERS, W. "*Les Fours électriques.*" Translated into French by L. Gautier. 8vo, pp. 246, with 292 illustrations. Paris: C. Béranger. (Price 15 francs.)

BRISKER, K. "*Einführung in das Studium der Eisenhüttenkunde.*" 8vo, pp. 172, with 99 illustrations. Leipzig: A. Felix. (Price 3s. 7d.)

"BRITISH ENGINEERING STANDARDS CODED LISTS." Vol. v.: "*Structural Steel for Shipbuilding and Marine Boilers, Steel Castings and Forgings for Marine Purposes.*" "*Marine Code,*" compiled by James Adamson. Issued by authority of the Engineering Standards Committee. 4to, pp. 412. London: R. Atkinson. (Price 25s. net.)

BUHLE, M. "*Massentransport.*" 8vo, pp. 388, with 895 illustrations and 80 tables. Stuttgart: Deutsche Verlags-Anstalt. (Price 20s.)
[A handbook of the transport and storage of material.]

CASSON, H. N. "*The Romance of Steel.*" 8vo, pp. 376. New York: A. S. Barnes & Co. (Price 10s.)

- CREMER, F. "*Chemische und metallographische Untersuchungen des Hartgusses.*" 8vo, with 6 plates. Göttingen. (Price 2s. 5d.)
- DAMOUR, E. "*Industrial Furnaces and Methods of Control.*" Translated by A. L. J. Queneau. Large 8vo, pp. 305. Illustrated. New York: Engineering and Mining Journal. (Price 16s.)
- DEINHARDT, K., and A. SCHLOMANN. "*Illustrierte Technische Wörterbücher in Sechs Sprachen.*" Band II., "*Die Electrotechnik.*" 8vo, pp. 2102, with 4000 illustrations. Munich: R. Oldenburg. (Price 25s.)
- "*Deutsches Museum von Meisterwerken der Naturwissenschaft und Technik. Führer durch die Sammlungen.*" 8vo, pp. 158. Leipzig: B. G. Teubner. (Price 1s.)
- [A guide to the collections of the new museum at Munich, which contains many metallurgical objects of great historical interest.]
- DUNAIME, P. "*Étude sur l'industrie du fer dans le nord des Ardennes françaises.*" 8vo, pp. 110, with 16 illustrations and 1 plate. Paris: Dunod. (Price 2½ francs.)
- ENGELHARDT, V. "*Elektrische Induktionsöfen und ihre Anwendung in der Eisen und Stahl-industrie.*" 8vo, pp. 35. (Reprint from the *Elektrotechnischen Zeitschrift.*) Berlin: M. Krayn.
- EYER, P. "*Die Eisenmaillierung.*" 8vo. Illustrated. Leipzig: F. Stoll. (Price 3s. 7d.)
- FORSYTHE, R. "*The Blast-furnace and the Manufacture of Pig Iron.*" 8vo, pp. 368. Illustrated. New York: David Williams Company. (Price 15s.)
- [An elementary treatise dealing with the materials of manufacture, description of plant, operation of the furnace, burdening the furnace, action within the furnace, furnace irregularities, and hints on design and equipment.]
- FRIEDLÄNDER, L. "*Feld- und Industriebahnen.*" 8vo, pp. 120, with 120 illustrations. Hanover: M. Jänecke. (Price 1s. 10d.)
- [A description of light railways for works.]
- GEITZ, A. "*Metallurgie.*" 2 vols. 8vo, pp. 330, with 21 illustrations. Leipzig: G. J. Göschen. (Price 1s. 7d.)
- [An elementary introduction to metallurgy containing a section on iron and steel.]
- "*Gemeinfassliche Darstellung des Eisenhüttenwesens.*" Issued by the Verein deutscher Eisenhüttenleute. 6th edition. 8vo, pp. 354. Illustrated. Düsseldorf: A. Bagel. (Price 4s.)
- [The original edition of this popular introduction to the metallurgy of iron was published in 1889. The present edition, brought up to date by the editorial staff of *Stahl und Eisen*, contains descriptions of the history of iron production, the manufacture of pig iron, of wrought iron and of steel, foundry practice and the testing of iron. A chapter has been devoted to electric steel smelting, describing the processes of Stassano, Kjellin, Röchling-Rodenhauser, Héroult and Girod; and under the head of the open-hearth steel process there are descriptions of the Bertrand-Thiel, Talbot, Monell, Surczycki and Hoesch processes. The second half of the work is devoted to the economic importance of the iron trade, statistics being given of the iron trade of the various countries of the world. An appendix contains a classified list of the iron and steelworks in Germany.]

- GOERENS, P. "*Introduction to Metallography.*" Translated by F. Ibbotson. 8vo, pp. 214, with 158 illustrations. London: Longmans, Green & Co. (Price 7s. 6d. net.)
 [Contains sections dealing with the physical properties of matter, the physical mixture, practical microscopy of metals, and special metallography of iron-carbon alloys. The last section differs from the original German in that it has been rewritten by the author.]
- GÖLDEL, P. "*Die Praxis und Theorie des Eisenbetons.*" 8vo, pp. 245. Berlin: Tonindustrie Zeitung. (Price 8s.)
- HAASE, E. "*Lötrohrpraktikum.*" 8vo, pp. 89, with 16 illustrations. Leipzig: E. Nägele. (Price 1s. 3d.)
 [An introduction to the blowpipe examination of minerals and ores.]
- HABERKALT, KARL, and FRITZ POSTUVANSCHITZ. "*Die Berechnung der Tragwerke aus Beton- Eisen oder Stampfbeton bei Hochbauten und Strassenbrücken.*" Auf Grund der Vorschriften des k.k. Ministeriums des Innern vom 15 November 1907. 8vo, pp. 290, with 173 illustrations and 14 plates. Vienna: J. Eberle. (Price 12s.)
- HANFSTENGEL, G. VON. "*Die Förderung von Massengütern.*" 8vo, pp. 252, with 414 illustrations. Berlin: J. Springer. (Price 7s.)
- HEESS, J. K. "*Practical Methods for the Iron and Steel Works Chemist.*" 8vo, pp. 60. Easton, Pa.: Chemical Publishing Co. (Price 4s. 6d.)
- HERZOG, S. "*Elektromechanische Anwendungen.*" 8vo, pp. 415, with 700 illustrations. Leipzig: J. A. Barth. (Price 20s.)
 [Contains abundant details regarding the applications of electricity in iron-works.]
- HOLMS, A. C. "*Practical Shipbuilding: A Treatise on the Structural Design and Building of Modern Steel Vessels.*" 2nd edition. 2 vols. Vol. i., text, 8vo, pp. 638. Vol. ii., diagrams, 4to. London: Longmans, Green & Co. (Price 30s.)
- JUNGE, F. E. "*Gas Power.*" 8vo, with 160 illustrations. New York. (Price 24s.)
- KIRSCHKE, A. "*Die Gaskraftmaschinen.*" 8vo, with 55 illustrations. Leipzig: G. J. Göschen. (Price 10d.)
- LEDEBUR, A. "*Leitfaden für Eisenhütten-Laboratorien.*" 8th edition. Revised by W. Heike. 8vo, pp. 167, with 23 illustrations. Brunswick: F. Vieweg & Son. (Price 4s. 6d.)
- LEDERER, ARTHUR, and R. WOLB. "*Analytische Ermittlung und Anwendung von Einflusslinien einiger im Eisenbetonbau häufig vorkommender statisch unbestimmter Träger.*" Imp. 8vo, pp. 88, with 113 illustrations and 23 plates. Berlin: Ernst & Sohn. (Price 4s. 3d.)
- LUDWIK, P. "*Die Kegelprobe.*" 8vo, pp. 35. Berlin: J. Springer. (Price 1s.)
 [Describes a new method of determining the hardness of materials.]
- MCMECHEN, F. L. "*Tests for Ores, Minerals, and Metals of Commercial Value.*" 8vo, pp. 151. New York: Van Nostrand Company. (Price 4s.)

- MARCHIS, L. "*Production et utilisation des gaz pauvres.*" 4to, pp. 322, with 325 illustrations and 30 plates. Paris: Dunod. (Price 20 francs.)
- MATSCHOSS, C. "*Die Entwicklung der Dampfmaschine.*" 8vo, 2 vols., pp. 1587, with 1853 illustrations. Berlin: J. Springer. (Price 24s.)
[An exhaustive history of the steam-engine.]
- MÜLLNER, ALFONS. "*Geschichte des Eisens in Inner-Österreich von der Urzeit bis zum Anfange des XIX. Jahrhunderts.*" Part I. Imp. 8vo, pp. 144. Illustrated. Vienna: Halm und Goldmann. (Price 5s.)
- MUSSAN, C. de. "*Résistance des Matériaux. Métaux.*" 8vo. Paris: J. Loubat. (Price 9 francs.)
- NATIONAL PHYSICAL LABORATORY. "*Collected Researches.*" Vol. iii. Large 4to, pp. 286. Teddington.
- NATIONAL PHYSICAL LABORATORY. "*Collected Researches.*" Vol. iv. Large 4to, pp. 252. Teddington.
- NEUBURGER, A. "*Handbuch der praktischen Elektro-Metallurgie.*" 8vo, pp. 466, with 119 illustrations. Munich: R. Oldenbourg. (Price 14s.)
[A quarter of the volume is devoted to electric iron and steel smelting.]
- NICOLARDOT, P. "*Industrie des Métaux Secondaires et des Terres Rares.*" 8vo, pp. 435, with 37 illustrations. Paris: O. Doin.
- PACORET, E. "*La technique de la houille blanche.*" 8vo, pp. 830, with numerous illustrations and 10 plates. Paris: Dunod. (Price £1.)
[An exhaustive treatise on water-power, dealing with hydrology, hydraulics, turbines, dams, electric stations, and electrometallurgy.]
- PILA, H. "*Allgemeines Profilverzeichnis der grossen deutschen Walzwerke.*" Duisburg: C. H. Jacke. (4 parts, price 4s. 6d. each.)
- RAGNO, S. "*La tecnologia delle saldature autogene dei metalli.*" 8vo, pp. 129, with 18 illustrations. Milan: U. Hoepli. (Price 1s. 10d.)
- ROSCOE, SIR H. E., and C. SCHORLEMMER. "*Treatise on Chemistry.*" Vol. ii. "The Metals." New edition. London: Macmillan & Co. (Price 30s.)
- RÖSSLE, K. "*Der Eisenbetonbau.*" 8vo, with 75 illustrations. Leipzig: G. J. Göschen. (Price 10d.)
- SALIGER, R. "*Der Eisenbeton in Theorie und Konstruktion.*" 2nd edition. 8vo, pp. 281, with 354 illustrations. Leipzig: A. Kröner. (Price 5s. 5d.)
- SALLOWS, J. F. "*The Blacksmith's Guide.*" 4½ inches by 7 inches. Pp. 157. Brattleboro, Vermont, U.S.A.: The Technical Press. (Price 6s.)
[Contains chapters on machine forging, tool forging, hardening and tempering, high-speed steel, case-hardening and colouring, and brazing.]
- SCHAROWSKY, C. "*Musterbuch für Eisenkonstruktionen.*" 4th edition. Edited by R. Kohnke. Foolscep folio, pp. 204, with numerous illustrations and 42 plates. Leipzig: O. Spamer. (Price 14s.)
- SCHINDLER, KARL. "*Die im Eisenhochbau gebräuchlichsten Konstruktionen schmiedeeiserner Säulen.*" Ein Handbuch für Ingenieure, Architekten, Techniker und Bauführer. 8vo, pp. 111, with 100 illustrations. Vienna: A. Hartleben. (Price 4s.)

- SCHÖMBURG, W. "*Elektrischer oder Dampftrieb für Reversierstrassen.*" 8vo, pp. 12, with 1 plate. Kattowitz: Böhm Brothers. (Price 1s.)
[A discussion of the relative merits of electrical and steam driving of reversing rolling-mills.]
- SONDERMANN, F. "*Geschichte der Eisenindustrie im Kreise Olpe.*" 8vo, pp. 172, with map. Münster: F. Copenrath. (Price 3s. 6d.)
- SPIELMANN, F. "*Verbrennungskraftmaschinen und Generatoren.*" 8vo, pp. 184, with 169 illustrations. Leipzig: J. J. Weber. (Price 6s.)
- STANSBIE, J. H. "*Iron and Steel.*" 8vo, pp. 375, with 86 illustrations. London: Archibald Constable & Co. (Price 6s.)
[A text-book, divided into fourteen chapters, dealing respectively with general principles, iron ores, fuels and fluxes, primitive methods of iron and steel production, pig iron manufacture, the refining of pig iron in small charges, crucible and weld steel, the Bessemer process, the open-hearth process, the mechanical treatment of iron and steel, physical and mechanical properties of iron and steel, iron and steel under the microscope, heat treatment of iron and steel, electric smelting, and special steels.]
- STANSFIELD, A. "*The Electric Furnace: Its Evolution, Theory, and Practice.*" 8vo, pp. 222, with 53 illustrations. Toronto: The Canadian Engineer. (Price 8s.)
- STILLICH, O., and H. STEUDEL. "*Eisenhütte.*" 8vo, pp. 157, with 62 illustrations. Leipzig: R. Voigtländer. (Price 4s.)
- STOUGHTON, B. "*The Metallurgy of Iron and Steel.*" 8vo, pp. 517, with 317 illustrations. New York: Hill Publishing Co. (Price 12s. 6d. net.)
[Contents: Introduction, iron and carbon—The manufacture of pig iron—The purification of pig iron—The manufacture of wrought iron and crucible steel—The Bessemer process—The open-hearth process—Defects in ingots—The mechanical treatment of steel—Iron and steel founding—The solution theory of iron and steel—The constitution of steel—The constitution of cast iron—Malleable cast iron—The heat treatment of steel—Alloy steels—The corrosion of iron and steel—The electrometallurgy of iron and steel—The metallurgy of iron and steel—Chemistry and physics introductory to metallurgy.]
- SUENSON, E. "*Jærnbeton.*" 8vo, pp. 216. Copenhagen. (Price 6s. 6d.)
[Lectures on reinforced concrete.]
- TOLDT, F. "*Regenerativ-Gasöfen.*" 3rd edition. Edited by F. Wileke. 8vo, with 32 illustrations and 9 plates. Leipzig. (Price 18s.)
- TURNER, T. "*The Metallurgy of Iron.*" 3rd edition. 8vo, pp. 478, with 120 illustrations. London: Charles Griffin & Co., Ltd. (Price 16s.)
[Important additions have been made, including a chapter on the gaseous products of the blast-furnace.]
- URSINUS, O. "*Moderne Schweissverfahren.*" With illustrations and 1 plate. Frankfurt. (Price 1s.)
- VOELCKER, H. "*Die deutsche Eisen- und Stahlindustrie.*" 8vo, pp. 80. Berlin: S. Simon. (Price 1s.)
- WALLICHS, A. "*Dreharbeit und Werkzeugstähle.*" 8vo, with 119 illustrations. Berlin: J. Springer. (Price 14s.)
[An authorized German translation of F. W. Taylor's memoir on the art of cutting metals.]

"*Watson's Drawing Down and Staving Scales.*" London: Longmans, Green & Company.

[This is a useful pocket scale, durably bound, and designed for the use of blacksmiths and forgers generally. It gives diagrams for forging round to round, and square to square, square to round, round to square, and flats.

WEDDING, H. "*Ausführliches Handbuch der Eisenhüttenkunde.*" Vol. iv. Part II. 8vo, pp. 199-576. Brunswick: F. Vieweg & Son. (Price 16s.)

[Deals with the preparation of wrought iron from pig iron, including the processes of refining, puddling, and cementation. Since the publication of this instalment of his monumental treatise, the author's death has been announced.]

WILKINS, CHARLES. "*The History of Merthyr Tydfil.*" Med. 8vo, pp. 587. Merthyr Tydfil: Joseph Williams.

Mining.

BEARD, J. T. "*Mine Gases and Explosions.*" Pp. 402, with 68 illustrations. New York City: John Wiley & Sons. (Price 3 dollars.)

BERTOLIO, S. "*Cave e miniere.*" 8vo, pp. 204, with 204 illustrations. Milan: U. Hoepli. (Price 16 francs.)

[Deals with mining geology, working quarries and mines, mining machinery, ore dressing and mining law.]

BOULTON, W. S. "*Practical Coal-Mining.*" Vol. iv. 8vo, pp. 211. London: Gresham Publishing Company.

BRATHUHN, O. "*Lehrbuch der praktischen Markscheidkunst.*" 4th edition. 8vo, pp. 420, with 394 illustrations. Leipzig: Veit & Co. (Price 11s.)

BROUGH, BENNETT H. "*A Treatise on Mine-Surveying.*" 13th edition, revised. 8vo, pp. 372, with 102 illustrations. London: Charles Griffin & Co., Ltd. (Price 7s. 6d.)

DAHME, A. "*Die Kolbenpumpe.*" 8vo, pp. 215, with 234 illustrations and 2 plates. Munich: R. Oldenbourg. (Price 7s. 6d.)

DAVID, T. W. EDGEWORTH. "*Geology of the Hunter River Coal Measures, New South Wales.*" 4to, pp. 372, with 43 plates, 70 illustrations, and 2 and 12 sections in portfolio. Sydney: Department of Mines. (Price 12s 6d.)

DAVIS, CHARLES A. "*Peat: Essays on its Origin, Uses, and Distribution in Michigan.*" 8vo, pp. 361. Lansing, Michigan: Michigan State Board of Geological Survey.

DITTMARSCH, A. "*Die Gewinnung der nutzbaren Mineralien von den Lagerstätten.*" 8vo, pp. 84, with 79 illustrations. Hanover: M. Jänecke (Price 1s. 3d.)

ENGLER, C. "*Die neueren Ansichten über die Entstehung des Erdöles.*" 8vo. pp. 67. Berlin: Verlag für Fachliteratur. (Price 2s.)

ESCALES, R. "*Nitroglycerin und Dynamit.*" 8vo, pp. 342, with portrait of A. Nobel and 61 illustrations. Leipzig: Veit & Co. (Price 11s.)

ESCHER, R. "*Die Theorie der Wasserturbinen.*" 8vo, pp. 279, with 242 illustrations. Berlin: J. Springer. (Price 8s.)

- FENTEN, A. and E. "*Leitfaden für die technische Behandlung von Bergschäden.*" 8vo, pp. 60, with 11 illustrations. Essen: H. L. Geck. (Price 1s. 6d.)
- FEUCHTINGER, R. "*Spreng- und Zündmittel-magazine (Sprengmittel-Verordnungen).*" 8vo, pp. 85, with 9 plates. Vienna: Spielhagen & Schurich. (Price 3s. 6d.)
- FREISE, F. "*Geschichte der Bergbau und Hüttentechnik.*" Vol. i. 8vo, pp. 187, with 87 illustrations. Berlin: J. Springer. (Price 6s.)
- "*Führer durch das nordwestböhmisches Braunkohlenrevier.*" 8vo, pp. 688, with 9 plates, 134 illustrations, and 2 maps. Teplitz-Schönau: Adolf Becker. (Price 7s. 6d.)
- GAEBLER, C. "*Das oberschlesische Steinkohlenbecken.*" 8vo, with 3 illustrations and 4 plates. Kattowitz (Price 15s.)
- GALDI, B. "*Notizie sui giacimenti di Lignite dell' Iglesiente.*" 8vo, pp. 56, with 6 plates. Rome: G. Bertero. (Price 1s. 6d.)
- GIBSON, WALCOT. "*The Geology of Coal and Coal-Mining.*" 8vo, pp. 341, with 8 plates and 37 illustrations. London: Edward Arnold. (Price 7s. 6d. net.)
- GIBSON, W., and others. "*The Geology of the Southern Part of the Derbyshire and Nottinghamshire Coalfield.*" Memoirs of the Geological Survey of England and Wales. London: F. Stanford. (Price 3s.)
- GUARINI, E. "*Le Pérou d'aujourd'hui et le Pérou de demain.*" 8vo, pp. 16. Paris: H. Dunod & E. Pinat. (Price 1 franc.)
[Describes the mineral resources of Peru, and shows that, by the introduction of electric power transmission and electric smelting, great developments are possible.]
- HACHE. "*Transportvorrichtungen für Massengüter wie Kohle, Erz, &c.*" 8vo, pp. 32, with 20 illustrations. Kattowitz: Böhm Brothers. (Price 1s. 6d.)
- HALSE, E. "*A Dictionary of Spanish and Spanish-American Mining, Metallurgical, and Allied Terms.*" 8vo, pp. 380, with 76 illustrations. London: Charles Griffin & Co., Ltd. (Price 10s. 6d. net.)
- HATCH, F. H., and E. J. VALLENTINE. "*Mining Tables.*" 8vo, pp. 200. London: Macmillan & Co., Ltd. (Price 6s. net.)
- HEISE, F., and F. HERBST. "*Lehrbuch der Bergbaukunde.*" Vol. i. Pp. 623, with 583 illustrations and 2 plates. Berlin: J. Springer. (Price 11s.)
[The first volume of a text-book of mining, with special reference to coal-mining.]
- JÜNGST, F. "*Die nutzbaren Lagerstätten.*" 8vo, pp. 183, with 100 illustrations. Hanover: M. Jänecke. (Price 2s. 5d.)
- KIRSOPP, JOHN. "*Supplement to the Plotted Vertical Sections of the Northumberland and Durham Coalfield.*" Foolscap folio, pp. 73. Gateshead on Tyne.
[Comprising full details respecting the present and past ownership of the mineral royalties, the nature and characters of the coals (with analyses), lists of collieries and their owners, and other matters of industrial and commercial interest connected with the coalfield.]

- KLEIN, G. "*Handbuch für den deutschen Braunkohlenbergbau.*" 8vo, pp. 504, with geological map, 13 plates, and 204 illustrations. Halle: W. Knapp. (Price 19s.)
- KRAUSE, C. "*Beiträge zur Geschichte der Entwicklung der Instrumente in der Markscheidkunde.*" 4to, pp. 49, with 44 illustrations. Freiberg: B. Naumann. (Price 4s.)
 [A historical review of the development of mine surveying instruments, with special reference to the use of the compass in mining.]
- LECOMTE-DENIS, M. "*La prospection des mines.*" 2nd edition. 8vo, with 329 illustrations. Paris. (Price 20 francs.)
- MCNEILL, BEDFORD. "*McNeill's Code*" (1908 edition). 8vo, pp. 1667. London: Whitehead, Morris & Co., Ltd. (Price 42s.)
- NEILL, J. S. "*British Minerals and Where to Find Them.*" 8vo. London: T. Murby & Co. (Price 2s.)
- OLIVER, T. "*Diseases of Occupation, from the Legislative, Social, and Medical Points of View.*" 8vo. London: Methuen & Co. (Price 10s. 6d.)
- PÜTZ, O. "*Le remblayage à l'eau.*" Translated into French by J. François. 8vo, pp. 89, with 44 illustrations. Paris: C. Béranger. (Price 5 francs.)
- RATEAU, A. "*Ventilateurs centrifuges de haute pression.*" 8vo, pp. 40, with 7 illustrations. Paris: Dunod. (Price 2 francs.)
- REDLICH, K. A. "*Der Eisensteinbergbau der Umgebung von Payerbach-Reichenau (Niederösterreich).*" 8vo, pp. 30, with 2 plates. Leoben: L. Nüssler. (Price 2s.)
- RICKARD, T. A. "*The Economics of Mining.*" Second edition. Revised. 8vo, pp. 380. New York: Hill Publishing Company. (Price \$2.00, cloth.)
- RITTER, E. A. "*The Origin of Ore Deposits.*" Pp. 84. Denver, Colorado: Ores and Metals Publishing Co. (Price 50 cents.)
- ROBERTY, K. "*L'industrie extractive en Tunisie.*" 8vo, pp. 160, with map. Tunis: Direction Générale des Travaux Publics. (Price 4 francs.)
 [An official publication containing a description of the iron ore mines.]
- ROST, F. "*Tiefbohrtechnik.*" 8vo, with 82 illustrations. Hanover. (Price 1s. 6d.)
- SCHORRIG, E. "*Die Verwendung von Druckluftbohrmaschinen.*" 8vo, with 24 illustrations. Freiberg: Craz & Gerlach. (Price 2s.)
- SCHWARZ, P. "*Festschrift für den 3. internationalen Petroleumkongress*" (Bucharest, September 1907). 8vo, pp. 125, with illustrations and 4 plates. Berlin: Verlag für Fachliteratur. (Price 15s.)
- SHAMEL, C. H. "*Mining, Mineral, and Geological Law.*" 8vo, pp. 627, with 103 illustrations. New York: Hill Publishing Co. (Price 5 dollars.)
 [A treatise on the mining law of the United States.]

- STEGMANN, B. "*Die Wetterwirthschaft im Bergwerksbetriebe.*" 8vo, pp. 271, with 128 illustrations. Hanover: M. Jänecke. (Price 3s. 6d.)
- STILLICH, O., and A. GERKE. "*Kohlenbergwerk.*" 8vo, pp. 141, with 56 illustrations. Leipzig: R. Voigtländer. (Price 4s.)
- STOKES, R. S. G. "*Mines and Minerals of the British Empire.*" 8vo, pp. 403, with 68 illustrations. London: Edward Arnold. (Price 15s. net.)
 [A description of the historical, physical, and industrial features of the principal centres of mineral production in the British dominions beyond the seas. Details are given of the occurrence of iron ore in Newfoundland, Canada, New South Wales, South Australia, and Queensland. The principal occurrences of nickel ore, manganese ore, molybdenum ore, tungsten ore, coal, oil shale, petroleum, and graphite are also described.]
- TANASESCO, J., and V. TACIT. "*L'exploitation du pétrole en Roumanie.*" With an atlas of 19 plates and 6 coloured maps. Bucharest. (Price 25s.)
- THOMANN, R. "*Die Wasserturbinen.*" 8vo, pp. 334, with 307 illustrations and 44 plates. Stuttgart: K. Wittwer. (Price 25s.)
- THOMPSON, A. BEEBY. "*The Oilfields of Russia and the Russian Petroleum Industry.*" 2nd edition. 8vo, pp. 430, illustrated. London: Crosby Lockwood & Son. (Price 21s. net.)
- TREPTOW, E. "*Grundzüge der Bergbaukunde.*" 4th edition. 8vo, pp. 608, with 814 illustrations. Vienna: Spielhagen & Schurich. (Price 11s.)
- UNITED STATES GEOLOGICAL SURVEY. "*Mineral Resources of the United States, 1906.*" 8vo, pp. 1307. Washington.
- URSINUS, O. "*Kalender für Tiefbohringenieur.*" 8vo, with coloured geological map of Germany. Frankfurt: "Vulcan." (Price 7s. 6d.)
- ZICKERT, H. "*Die wirtschaftliche Bedeutung der Böhmisches Braunkohlen.*" 8vo, pp. 300, with 24 tables, 15 plates, and 2 maps. Teplitz-Schönau: A. Becker. (Price 10s.)
 [Deals with the development of the production and consumption of Bohemian brown-coal from the middle of the nineteenth century to 1906, the present condition of the industry, and statistics.]

INDEX.

A.

- ABBOTT, F. E., on American rolling-mills, 345.
Abbott, F. E., on rails, 365.
Abell, O. J., on iron ore on Lake Superior, 237.
Accidents in mines and quarries in the United Kingdom, 423.
Accounts, statement of, 16, 17.
Acheson, E. G., on graphite, 253.
Ackermann, E., on petroleum in Portugal, 278.
Adair, Alfred, on iron and steel in Transvaal Colony, 439.
Adam, A., on calorimetry, 256.
Adams, B., on mineral statistics of Orange River Colony, 436.
Adams, E. T., on blast-furnace gases, 317.
Adamson, Joseph, remarks by, 21.
Additions to the Library, 222.
Adirondack Region, iron ore in, 238.
Aguillon, L., on mineral statistics of Prussia, 433.
Ahlburg, on iron ore in Austria, 232.
Ahles, Robert L., elected member, 1.
Air, compressed, at collieries, 292.
Åkerman, E., on magnetic separators, 249.
Alabama, coal in, 265.
Aliamet, M., on pyrometry, 257.
Alimanestianu, V., on coal in Roumania, 261.
Alimanestianu, V., on methods of working coal, 294.
Allen, A. H., on occluded gases in steel, 401.
Allen, H., on blast-furnace gases, 317.
Allen, P. R., on blast-furnace gases, 317
Allen, P. R., on gas-engines, 288.
Allen, W. A. T., on asphalt, 283.
Alleyne, Sir J. G. N., vote of thanks by, 23.
Alleyne, Reynold Henry Newton, obituary notice of, 212
Allison, Archibald, elected member, 1.
Alloys, iron, used in the steel industry, 362.
Alloys, iron-chromium, 393.
Alloys, iron-tungsten, 393.
Alloys, solidification points and transformation in, 381.
American blast-furnaces, 319.
American foundries, 328.
American Iron and Steel Association, book on metallurgy, by, 448.
American rolling-mills, 344.
Anderson, Miss A. M., on dangerous tinning processes, 372.
Anderson, R., on petroleum in California, 281.
Andreics, J., on coal in Hungary, 261.
Andrussoff, N. I., on origin of petroleum, 276.

- Annealing furnaces, 357.
Annual dinner, 183.
Annual general meeting, 1.
Appointment of representatives, 14.
Aradi, V., on petroleum in Roumania, 278.
Archibald, Henry, biography of, 321.
Argentine Republic, petroleum in, 282.
Arkansas, coal in, 265.
Armour-plate vault, 371.
Armour-plates and projectiles, 370.
Arnold, J. O., on improvement of quality of steel masses, 359
Arnold, J. O., on microstructure of iron and steel, 379.
Arnold, J. O., on testing hardened steel, 387.
Arnold, R., on petroleum in California, 281.
Arnoux, on pyrometry, 257.
Artificial gas, 286.
Ashworth, James, on colliery explosions, 300.
Ashworth, James, on explosives in collieries, 291.
Asphalt, 282.
Asphalt mining in Turkey, 439.
Athansiu, S., on petroleum in Roumania, 278.
Atkinson, W. N., on colliery explosions, 300.
Auel, C. B., on welding, 369.
Austria, coal in, 260.
Austria, iron ore in, 231.
Austria, mineral statistics of, 424.
Austria, petroleum in, 277.
Austria, steelworks in, 350.
Austrian blast-furnaces, 318.
Automatic gas analysis, 419.

B.

- BACH, C., on elastic properties of steel, 306.
Bach, C., on tests of hollow cylinders, 388.
Backwinkel, R., on life-saving appliances, 303.
Baden-Powell, R. S. S., speech at dinner by, 189.
Baer, H., on blast-furnace gases, 317.
Bain, H. F., on petroleum in the United States, 444.
Bain, James, on life-saving appliances, 302.
Bajkow, A., on composition of slag in cast steel, 405.
Baker, T., award of Carnegie Scholarship to, 26.
Balance-sheet, 17.
Baldwin, Alfred, obituary notice of, 213.
Barkow, R., on gas-producers, 286.
Barlow, T. M., on magnetic properties of iron and steel, 383.
Barnes, J. S., on winding appliances, 298.
Barnhart, E., on methods of gas analysis, 419.
Barnitzke, J. E., on metallurgical education in Germany, 433.
Bärtling, R., on iron ore in Sweden, 233.
Bartsch, J., on magnetic separators, 249.
Basic charges, Bessemer, Flohr addition to, 353.
Bauer, O., on metallography, 381.
Baum, G., on coal in the United States, 265, 443.
Baum, G., on mineral statistics of Belgium, 425.

- Baumann, R., on formation of cracks in plates, 388.
 Baumann, R., on metallography, 380.
 Baur, on occluded gases in steel, 403.
 Bavarian workmen's museum, 433.
 Beard, J. T., book on mining by, 453.
 Beardmore, W., biography of, 321.
 Beardshaw, W. F., vote of thanks by, 21.
 Becher, R. A., on manganese ore in Portuguese colonies, 240.
 Becker, J., on pyrometry, 257.
 Becker, L., on winding-engines, 297.
 Beckmann, W., on explosives and blasting, 242.
 Bedson, P. P., on chemistry of coal, 258.
 Bedson, P. P., on colliery explosions, 301.
 Beehive coke-ovens, 272.
 Belgium, coal in, 260.
 Belgium, iron trade statistics of, 425.
 Belgium, mineral statistics of, 425.
 Bell, Sir Hugh, Bart., acknowledgment of vote of thanks by, 22, 29.
 Bell, Sir Hugh, Bart., on application of colour photography to metallography, 153.
 Bell, Sir Hugh, Bart., on cast iron in the construction of chemical plant, 79.
 Bell, Sir Hugh, Bart., on improvements in plate rolling-mills, 48.
 Bell, Sir Hugh, Bart., on the metallurgical and chemical laboratories in the National Physical Laboratory, 107.
 Bell, Sir Hugh, Bart., remarks on meeting in Middlesbrough, 29.
 Bell, Sir Hugh, Bart., speech at dinner by, 194.
 Bell, Sir Hugh, Bart., speech on presentation of Bessemer Gold Medal, 23.
 Bell, Sir Hugh, Bart., speech on presentation of Carnegie Gold Medal, 27.
 Bell, Sir Hugh, Bart., vote of thanks by, 28.
 Bell, H. P., on gas-producers, 286.
 Bell, J. J., on coal in Canada, 262.
 Bell, J. M., on coal in New Zealand, 264.
 Bell, J. M., on iron ore in New Zealand, 236.
 Bellamy, A. R., on cupola practice, 324, 325.
 Belloc, G., on occluded gases in steel, 399.
 Bement, A., on determination of volatile matter, 418.
 Bement, A., on fuel value of coal, 257.
 Bender, O., book on metallurgy by, 448.
 Bending tests, 386.
 Benedicks, Carl, award of Carnegie Gold Medal to, 26, 28.
 Benedicks, C., on history of steel, 348.
 Benedicks, C., on pyrometric installation in the Royal Gun and Carriage Factories, Woolwich, 134.
 Benedicks, C., on solubility of graphite in iron, 407.
 Benjamin, C. H., on graphite, 253.
 Bennie, P. McN., on magnetic separators, 249.
 Bergström, H., on peat-coke, 276.
 Beringer, J. J., book on metallurgy by, 448.
 Bernauer, Isidor, on causes of damages to gas-pipes by the electric current, 389.
 Bernstein, P., on compressed air in mines, 243.
 Bertelsmann, W., on calorimetry, 256.
 Bertolio, S., book on mining by, 453.
 Bessemer and open-hearth processes, comparison of, 355.
 Bessemer basic charges, Flohr addition to, 353.
 Bessemer Medal, presentation of, 23.
 Bessemer plant, small, 355.
 Bessemer process, 353.
 Bibliography, 448.

- Birkinbine, J., on iron ore in the United States, 442, 443.
Birnbaum, Z., on development of Berlin School of Mines, 433.
Bitumen, 283.
Bladen, Thomas, elected member, 1.
Blascheck, A., on coal in Hungary, 261.
Blast-furnace and Portland cement, 324.
Blast-furnace gases, 314.
Blast-furnace linings, destructive action of graphite on, 311.
Blast-furnace practice, 308.
Blast-furnace slag, utilisation of, 137.
Blast-furnace slags, 323.
Blast-furnace slags, bricks from, 324.
Blast-furnace, theory of, 308.
Blast-furnace, zinc in, 312.
Blast-furnaces, American, 319.
Blast-furnaces, Austrian, 318.
Blast-furnaces, Canadian, 319.
Blast-furnaces, German, 319.
Blast-furnaces, Hungarian, 319.
Blast-furnaces, Indian, 319.
Blast-furnaces, Italian, 319.
Blast-furnaces, scaffolding at, 310.
Blast-furnaces, use of phosphatic chalk in, 312.
Blasting, 242.
Blauel, C., on iron industry of China, 427.
Blowing-engines, 313.
Bock, F., on briquette manufacture, 306.
Bock, F., on electric welding, 359.
Bodifée, E., on formation of ore deposits, 230.
Bodifée, E., on methods of working coal, 293.
Boecker, Martin, elected member, 1.
Boecklin, Werner, on handling iron ore, 248.
Böhler, R. F., award of Carnegie Scholarship to, 26.
Böhler, Richard Friedrich, elected member, 1.
Boiler feed-water, purifying, 313.
Böker, M., on provident funds in Prussia, 434.
Bolle, J., on colliery explosions, 300.
Bolle, J., on explosives in collieries, 291.
Bonanos, M., on iron ore in Greece, 232.
Bone, W. A., on apparatus for gas analysis, 419.
Bonte, H., on blast-furnace gases, 317.
Booth, W. H., on gas-engines, 288.
Borchers, W., book on metallurgy by, 448.
Boring, deep, 242.
Boring for petroleum, 284.
Borneo, petroleum in, 282.
Bosnia, coal in, 260.
Bosnia, iron ore in, 282.
Botz, N., on origin of petroleum, 277.
Boudouard, O., on occluded gases in steel, 399, 400.
Boulton, W. S., book on mining by, 453.
Bräcke, O., on forging presses, 341.
Bräcke, O., on rolling-mills, 344.
Brady, F. W., on petroleum in West Virginia, 281.
Brathuhn, O., book on mining by, 453.
Braune, H., on occluded gases in steel, 400, 401.
Bravo, J. J., on vanadium ore, 241.

- Brazilian pig iron, 323.
 Brearley, Arthur William, elected member, 2.
 Breckenridge, L. P., on smoke abatement, 258.
 Breckenridge, L. P., on steam-boiler heating, 257.
 Breuil, P., on constituents of hardened steels, 388.
 Bricks from blast-furnace slags, 324.
 Bridges, railway, load for, 389.
 Briggs, H., on colliery explosions, 301.
 Briggs, H., on methods of working coal, 296.
 Briquette manufacture, 306.
 Briquetting iron ore, 249.
 Brisker, K., on theory of the blast-furnace, 308.
 Brisker, K., book on metallurgy by, 448.
 Bristol, W. H., on pyrometry, 267.
 British East Africa, coal in, 263.
 British East Africa, iron ore in, 236.
 British Engineering Standards Coded Lists, 448.
 Brough, Bennett H., book on mining by, 453.
 Brough, Bennett H., *report* by, on the Mining and Metallurgical Congress at St. Etienne, 203.
 Brough, J. W., on utilisation of blast-furnace slag, 149.
 Brumell, H. P. H., on graphite, 252.
 Brunck, O., on determination of nickel, 414.
 Brunton, J. Dixon, biography of, 321.
 Brussell, J. B. van, on armour-plates and projectiles, 370.
 Brussell, J. B. van, on electricity in iron ore mines, 245.
 Brussell, J. B. van, on German blast-furnaces, 319.
 Buchanan, C. P., on causes of damages to gas-pipes by the electric current, 390.
 Buchanan, R., on cupola practice, 325.
 Buffet, E. P., on history of iron, 321.
 Buffet, E. P., on life-saving appliances, 304.
 Buffet, E. P., on needles, 372.
 Buhle, M., book on metallurgy by, 448.
 Buhle, M., on works machinery, 313.
 Bulask, F., on briquette manufacture, 307.
 Bulgaria, mining law of, 425.
 Burchard, E. F., on mineral statistics of the United States, 440.
 Burnett, A., on economics of mining, 304.
 Burnite, T. B., on rock-drills, 243.
 Burrows, J. G., on sampling coal, 271.
 Burstall, F. W., on apparatus for gas analysis, 418.
 Burstall, F. W., on gas-engines, 287.
 Bursting-point of flanged fittings, 390.
 Butler, J., on bricks from blast-furnace slags, 324.
 Butlin, W. H., biography of, 321.
 Butts, Charles, on coal in Alabama, 265.
 Buzek, G., on cupola practice, 325.
 By-product coke-ovens, 273.
 By-products, charcoal, 271.

C.

- CAIRNES, D. D., on coal in Canada, 262.
 Calcining kilns, 260.
 California, coal in, 265.
 California, petroleum in, 281.

- Callendar, H. L., on blast-furnace gases, 317.
Calorific value of fuel, 255.
Calorimetry, 255.
Calhane, D. F., on impure nickel plate, 411.
Campbell, M. R., on coal-handling, 306.
Campbell, M. R., on coal in California, 266.
Campbell, M. R., on coal in New Mexico, 267.
Campbell, M. R., on mineral statistics of the United States, 440.
Canada, coal in, 262.
Canada, iron ore in, 234.
Canada, iron trade statistics of, 426.
Canada, mineral statistics of, 425.
Canada, natural gas in, 284.
Canada, open-hearth steelworks in, 351.
Canada, petroleum in, 279.
Canadian blast-furnaces, 319.
Canet, Gustave, on ordnance, 371.
Cantoni, H., on determination of nickel, 414.
Cape Colony, coal in, 263.
Cape Colony, manganese ore in, 239.
Carbon and hydrogen, direct union of, at high temperatures, 404.
Carbon, determination of, 412.
Carbon, graphitic, in pig iron, 407.
Carborundum crystals in steel, 404.
Carburisation of malleable iron, 348.
Carlsson, C. W., on small Bessemer plant, 355.
Carnegie Gold Medal, presentation of, 27.
Carnegie Research Scholarships, 26.
Carnot, on sources of error in determination of phosphorus, 413.
Carr, W. M., on comparison of Bessemer and open-hearth processes, 355.
Cartwright, F., on history of iron, 320.
Carulla, F. J. R., *paper* on "Cast iron in the construction of chemical plant," 71.—*Discussion*: T. Turner (Birmingham), 76, 78; F. W. Harbord, 77; J. E. Stead, 77; F. W. Paul, 78; F. J. R. Carulla, 78, 85; Sir Hugh Bell, Bart., 79.—*Correspondence*: G. Keville Davis, 80; W. H. Fryer, 81; J. Grossmann, 81; W. G. Haslam, 82; H. Hemingway, 82; E. Jackson, 82; J. F. Kempson, 83; G. Lunge, 83; T. Tyrer, 84; J. Wallace, 84; J. T. Wood, 84; C. F. Wülffing, 84.
Case-hardening, 179, 357.
Case-hardening, theory of, 386.
Casson, H. N., book on metallurgy by, 448.
Cast iron and steel, influence of gases on the structure of, 378.
Cast iron in the construction of chemical plant, 71.
Cast iron, nickel, 393.
Cast iron, physical properties of, 385.
Cast iron pipes, 331.
Cast steel, composition of slag in, 405.
Cast steel, influence of gases on the structure of, 378.
Casting iron in metallic moulds, 329.
Castings, cleaning, 331.
Castings, large, 330.
Castings, malleable, 330.
Castings, semi-steel, 330.
Castings, steel, 361.
Catani, R., on scaffolding at blast-furnaces, 310.
Catlett, C., on determination of magnesia, 417.
Catlett, C., on iron ore in Cuba, 238.
Caucasus, mineral production of, 436.

- Cement, Portland and blast-furnace, 324.
Chain links, strength of, 391.
Chalk, phosphatic, for blast-furnace use, 312.
Chapman, F., on coal in Western Australia, 264.
Chapman, W. B., on gas-producers, 286.
Charcoal, 271.
Charcoal by-products, 271.
Charcoal industry in Sweden, 271.
Charcoal kilns, 271.
Charging arrangements, 313.
Charitschkoff, K. V., on asphalt, 283.
Charitschkoff, K. V., on petroleum in Russia, 278.
Charlton, W., on methods of working coal, 293.
Charpy, G., on graphite and graphitic carbon in pig iron, 407.
Charpy, G., on solubility of graphite in iron, 406, 407.
Chauvin, on pyrometry, 257.
Chemical analysis, 412.
Chemical and metallurgical laboratories in the National Physical Laboratory, 87.
Chemical composition of pig iron, 322.
Chemical plant, cast iron in the construction of, 71.
Chemical properties, 399.
Chemistry in the foundry, 327.
Chemistry of coal, 258.
Chesneau, G., on lighting of collieries, 302.
Chesneau, G., on sources of error in determination of phosphorus, 413.
China, iron industry of, 427.
China, mineral statistics of, 426.
Chinese and Japanese foundries, 328.
Christen, Oscar, elected member, 2.
Christie, J., on physical properties of cast iron, 385.
Christie, T. T., on coal-screening, 306.
Chromium, determination of, 414.
Chubb, J. W., on pyrometry, 256.
Circular saws, toothless, action of, 390.
Cirkel, F., on mineral statistics of Canada, 426.
Clapp, F. G., on natural gas in Pennsylvania, 285.
Clapp, F. G., on petroleum in Pennsylvania, 281.
Clark, H., on coal-screening, 306.
Clark, H., on pit-head frames, 298.
Cleaning castings, 331.
Cleghorn, M. P., on producer-gas for power purposes, 287.
Clift, Arthur Stebbins, elected member, 2.
Clowes, F., on gases in mines, 299.
Coal, 258.
Coal analysis, 417.
Coal, chemistry of, 258.
Coal-cutting machinery, 292.
Coal, fuel value of, 257.
Coal-handling, 306.
Coal, methods of working, 293.
Coal-mining, 289.
Coal-mining, history of, 304.
Coal, sampling, 270.
Coal-screening, 306.
Coal, search for, 290.
Coal-washing, 306.
Coal, weathering of, 270.

- Coal-wedge, 291.
Coal, world's production of, 445.
Cohesion of steel, 379.
Coke, 272.
Coke-oven gases, 276.
Coke-ovens, beehive, 272.
Coke-ovens, by-product, 273.
Coke, production of, in the United States, 444.
Coleman, A. P., on iron ore in Canada, 234.
Coleman, W. H., on by-product coke-ovens, 273.
Collier, A. J., on coal in Arkansas, 265.
Collier, A. J., on mineral statistics of the United States, 440
Collieries, compressed air at, 292.
Collieries, electricity in, 291.
Collieries, explosives in, 291.
Collieries, lighting of, 302.
Colliery explosions, 299.
Collingham, R. H., on winding, 245.
Colloseus, Heinz, elected member, 2.
Colorado, coal in, 266.
Colour photography, application of, to metallography, 151.
Comparative mineral statistics, 446.
Comparative tables, 444.
Compressed air at collieries, 292.
Compressed air in mines, 243.
Compression of steel ingots, 360.
Condrea, C., on colour of ferric oxide, 404.
Constituents of hardened steels, 388.
Copeland, Charles John, obituary notice of, 213.
Coppelovici, M., on boring for petroleum, 284.
Copper-iron alloys, 409.
Corea, petroleum in, 282.
Corkill, E. T., on iron ore in Canada, 234.
Cornu, F., on magnesite, 263.
Corrosion of iron and steel, 410.
Corrugation of tramway rails, 392.
Coste, E., on petroleum in Canada, 279.
Council Report, 5.
Cowell, Richard Ernest, elected member, 2.
Cowper-Coles, S., biography of, 322.
Cox, C. N., on titaniferous slags, 323.
Cracks in plates, formation of, 388.
Cremer, F., book on metallurgy by, 449.
Cremer, R., on lighting of collieries, 302.
Cross, William, elected member, 2.
Crowe, H., on electricity in rolling-mills, 342.
Crowe, H., on improvements in plate rolling-mills, 44.
Crucible steel, 348.
Crucible tongs, 348.
Crystallisation of steel, 378.
Cuba, iron ore in, 238.
Cunningham, P. N., on improvements in plate rolling-mills, 42.
Cupola blowers, 325.
Cupola practice, 324.
Cupola slag, recovery of iron from, 328.
Cushman, A. S., on corrosion of iron and steel, 410.
Cylinders, hollow, tests of, 388.

D.

- DAHME, A., book on mining by, 453.
 Dalby, W. E., on blast-furnace gases, 317.
 Dalton, Archibald Cecil, elected member, 2.
 Damour, E., book on metallurgy by, 449.
 Danks, J. G., on Danks puddling furnace, 333.
 Darton, N. H., on coal in Montana, 267.
 Dautriche, on explosives in collieries, 291.
 David, T. W. E., book on mining by, 453.
 David, T. W. E., on coal in New South Wales, 263.
 Davies, Daniel, on mine drainage, 299.
 Davies, Henry, obituary notice of, 213.
 Davies, William Robert, elected member, 2.
 Davis, C. A., book on mining by, 453.
 Davis, C. H., on coal in Kentucky, 266.
 Davis, G. K., on cast iron in the construction of chemical plant, 80.
 Day, D. T., on mineral statistics of the United States, 439, 440.
 Day, D. T., on Petroleum Congress at Bucharest, 282.
 Dean, G. W., on determination of silica, 416.
 Dean, W. T., on electricity in rolling-mills, 348.
 Decarburisation of iron, 332.
 Deep boring, 242.
 Deformation of metals, permanent, 385.
 Deinhardt, K., book on metallurgy by, 449.
 Dejust, H. L., on graphite, 253.
 Delamater, G. R., on coal-washing, 305.
 Del Mar, A., on rock drills, 243.
 Dessila, V., on petroleum in Roumania, 278.
 Deutsch, Felix, elected member, 2.
 Devonshire, His Grace the Duke of, obituary notice of, 210.
 De Wolf, F. W., on coal in Illinois, 266.
 De Wolf, F. W., on fireclays, 251.
 Diamond and carborundum crystals in steel, 404.
 Dickinson, John, obituary notice of, 214.
 Dickinson, Joseph, on coal in the Midlands, 259.
 Dieterich, G., on nickel ore in New Caledonia, 240.
 Dinner, annual, 183.
 Dinner to Mr. R. A. Hadfield, 227.
 Direct production of wrought iron, 332.
 Dittmarsch, A., book on mining by, 453.
 Ditz, H., on precipitation of iron from pyrites, 411.
 Dixon, Cuthbert, elected member, 2.
 Dobbelstein, O., on methods of working coal, 293.
 Dolomite, 254.
 Donati, L., on magnetic properties of iron and steel, 384.
 Döring, T., on coal in Germany, 260.
 Dorman, Arthur, jun., elected member, 2.
 Dosch, A., on methods of gas analysis, 419.
 Dowling, D. B., on coal in Canada, 262, 263.
 Drakenberg, G., on steel castings, 361.
 Dron, R. W., on iron ore in Great Britain, 231.
 Drucker, H., on manganese ore in Hungary, 239.
 Drummond, G. D., on Canadian blast-furnaces, 319.

- Drummond, G. D., on ironworks analysis, 412.
 Drying ovens, 330.
 Duchemin, R., on charcoal kilns, 271.
 Duckering, G. E., on tinning, 372.
 Dudley, W. L., on corrosion of iron and steel, 410.
 Dueñas, E. I., on coal in Peru, 269.
 Dueñas, E. I., on iron ore in Peru, 238.
 Dueñas, E. I., on petroleum in Peru, 282.
 Duff, E. J., on improvements in plate rolling-mills, 45.
 Dunaimé, P., book on metallurgy by, 449.
 Dunaimé, P., on iron trade statistics of France, 431.
 Dunstan, W. R., on iron ore in Nyassaland, 237.
 Duplex metal, 372.
 Duplex steel-making process, 355.
 Durnerin, M., on underground temperature, 289.
 Durrans, Paul, elected member, 2.

E.

- EAKINS, L. G., on determination of silica, 416.
 Eckel, E. C., on iron trade statistics of the United States, 442.
 Eckel, E. C., on mineral statistics of the United States, 440.
 Eckel, E. C., on world's production of iron ore, 446.
 Eckwaldt, on foundry mixtures, 326.
 Economics of mining, 247, 304.
 Edwards, G. E., on iron ore on Lake Superior, 237.
 Ehrensberger, E., on impact testing, 386.
 Ehrenwerth, J. von, on electric smelting of iron, 334.
 Elastic properties of steel, 395.
 Eldred, B. E., on duplex metal, 372.
 Electric current, causes of damages by, to gas-pipes, 389.
 Electric furnace for the smelting of iron, new type of, 155.
 Electric furnaces for foundry work, 327.
 Electric smelting of iron, 333.
 Electric smelting, special processes of, 336.
 Electricity in collieries, 291.
 Electricity in iron ore mines, 245.
 Electricity in rolling-mills, 342.
 Electrolytic pickling of steel, 372.
 Eills, R. W., on asphalt, 283.
 Eills, R. W., on iron ore in Canada, 234.
 Eills, R. W., on petroleum in the West Indies, 279.
 Eminger, W., on deep boring, 242.
 Engelhardt, V., book on metallurgy by, 449.
 Engler, C., book on mining by, 453.
 Engler, C., on origin of petroleum, 277.
 Ennis, W. D., on steam-boiler heating, 258.
 Equilibrium in the iron-carbon system, theory of, 405.
 Ercolini, G., on determination of iron, 416.
 Ernst, E. U. G., on calorimetry, 256.
 Erone, J., on metallography, 380.
 Escales, R., book on mining by, 453.
 Escher, R., book on mining by, 454.
 Estep, H. C., on American foundries, 328.
 Etheridge, R., on coal in Western Australia, 264.

Exhibitions in the United Kingdom, 423.
 Explosions, colliery, 299.
 Explosives, 242.
 Explosives in collieries, 291.
 Eyer, P., book on metallurgy by, 449.

F.

FABER, P., on determination of titanium, 415.
 Fabre, L., on automatic gas analysis, 420.
 Fatigue test for iron and steel, new, 54.
 Fearnough, Walter, obituary notice of, 214.
 Fearnshides, W. G., on iron ore in Great Britain, 230.
 Fenten, A., book on mining by, 454.
 Fenten, E., book on mining by, 454.
 Fermor, L. L., on iron ore in India, 235.
 Fermor, L. L., on manganese ore in India, 239.
 Fermor, L. L., on meteorites, 242.
 Fernald, R. L., on producer-gas for power purposes, 287.
 Ferric oxide, colour of, 404.
 Ferro-silicon, 404.
 Ferro-titanium, 394.
 Féry, C., on calorimetry, 255.
 Feuchinger, R., book on mining by, 454.
 Ficsinesco, T., on petroleum in Roumania, 278.
 Field, George Kenelm, elected member, 2.
 Fiero, S. T., on rails, 365.
 Fieschi, F., on by-product coke-ovens, 274.
 Finance, 9.
 Finlayson, F., on improvements in plate rolling-mills, 49.
 Firebricks, manufacture of, 251.
 Fireclays, 251.
 Fires, underground, 302.
 Firth, A., appointed scrutineer, 1.
 Fisher, C. A., on coal in Montana, 267.
 Fisher, C. A., on coal in Wyoming, 268.
 Fisher, C. A., on natural gas in Wyoming, 285.
 Fisher, C. A., on petroleum in Wyoming, 281.
 Fisher, G. J., on mine drainage, 299.
 Flamand, G. B. M., on coal in the Sahara, 269.
 Flanged fittings, bursting-point of, 390.
 Flather, William Thomas, obituary notice of, 214.
 Fletcher, J. E., on influence of gases on the structure of cast iron and steel, 378.
 Flohr, J., on additions to Bessemer basic charges, 353.
 Fluhr, Robert, on iron ore in Germany, 232.
 Fluhr, Robert, on Würtemberg pig iron, 323.
 Foerster, M., on reinforced concrete, 370.
 Forcher von Ainbach, F., on history of iron, 321.
 Forge and mill machinery, 341.
 Forging presses, 341.
 Formation of ore deposits, 230.
 Forsythe, R., book on metallurgy by, 449.
 Foundries, American, 328.
 Foundries, Japanese and Chinese, 328.
 Foundry appliances, 326.
 Foundry, chemistry in, 327.

- Foundry mixtures, 326.
Foundry practice, 324.
Foundry work, electric furnaces for, 327.
Foundry work, machine-cast and sand-cast pig iron for, 327.
Fowler, G. L., on corrugation of tramway rails, 392.
France, iron ore in, 232.
France, iron trade statistics of, 430.
France, mineral statistics of, 429.
France, oil shale in, 283.
Franco-British Exhibition, 423.
Frank, M., on determination of phosphorus, 413.
Frankforter, G. B., on determination of moisture, 418.
Fraser, L., on coal in Michigan, 266.
Fraser, William, elected member, 2.
Freise, F., book on mining by, 454.
Freise, F., on fireclays, 251.
Freise, F., on metallography, 380.
Freise, F., on underground haulage, 296.
Freyberg, M., on iron ore transport, 247.
Friedländer, L., book on metallurgy by, 449.
Friedrich, K., on ironworks analysis, 412.
Frödning, M., on calcining kilns, 250.
Frölich, F., on steelworks equipment, 352.
Frucht, Julius, on uses of petroleum, 284.
Fryer, W. H., on cast iron in the construction of chemical plant, 81.
Fuel, 255.
Fuel, analysis of, 417.
Fuel, calorific value of, 255.
Fuel value of coal, 257.
Furnaces, electric, for foundry work, 327.
Further treatment of iron and steel, 357.
Fusibility of lime-alumina-silica mixtures, 323.
Futers, T. C., on coal-washing, 305.
Futers, T. C., on underground haulage, 296.

G.

- GABERT, C., on coal in Germany, 260.
Gaebler, C., book on mining by, 454.
Gaebler, C., on coal in Germany, 260.
Gahl, W., on metallography, 381.
Galdi, B., book on mining by, 454.
Gale, H. S., on coal in Colorado, 266.
Gallo, G., on determination of chromium, 414.
Gallo, G., on ironworks analysis, 412.
Galloway, W., on colliery explosions, 302.
Galocsy, A., on iron ore in Bosnia, 232.
Gammage, A. L., on impure nickel plate, 411.
Garrett, George, obituary notice of, 214.
Garson, Stanley Treavor, elected member, 2.
Gas analysis, apparatus for, 418.
Gas analysis, automatic, 419.
Gas analysis, methods of, 419.
Gas, artificial, 286.
Gas cleaning, 318.
Gas-engines, 287.

- Gas, natural, 284.
 Gas-pipes, causes of damages to, by electric current, 389.
 Gas-producers, 286.
 Gases, blast-furnace, 314.
 Gases, coke-oven, 276.
 Gases in mines, 299.
 Gases, influence of, on the structure of cast iron and steel, 378.
 Gases, occluded, in steel, 399.
 Gaster, L., on Petroleum Congress at Bucharest, 282.
 Gay, H. S., on methods of working coal, 293.
 Geer, W. C., on charcoal by-products, 271.
 Geitz, A., book on metallurgy by, 449.
 Genart, A., on mine drainage, 298.
 George, H. C., on petroleum in the United States, 444.
 Gerke, A., book on mining by, 456.
 German blast-furnaces, 319.
 German museum at Munich, 433.
 German pig iron, analyses of, 322.
 Germany, coal in, 260.
 Germany, iron ore in, 232.
 Germany, iron trade statistics of, 432.
 Germany, metallurgical education in, 433.
 Germany, mineral statistics of, 431.
 Germany, open-hearth steel works in, 351.
 Gervais, F., on coal in Russia, 261.
 Gervais, F., on iron ore in Russia, 233.
 Gessner, A., on hardness of steel, 376.
 Gherardi, G., on high-speed steel, 361.
 Gibson, C. G., on iron ore in Western Australia, 235.
 Gibson, T. W., on mineral statistics of Canada, 426.
 Gibson, W., book on mining by, 454.
 Giesen, W., award of Carnegie Scholarship to, 26.
 Gilbert, G. K., on steel for structural purposes, 368.
 Gin, G., on special processes of electric smelting, 339.
 Giolitti, F., on metallography, 380.
 Gledhill, J. M., on improvements in plate rolling-mills, 41.
 Gledhill, J. M., on new fatigue test for iron and steel, 63.
 Gledhill, J. M., on pyrometric installation in the Royal Gun and Carriage Factories, Woolwich, 132.
 Glidden, J. T., on rock-drills, 343.
 Gloz, Adolf, elected member, 2.
 Goerens, P., book on metallurgy by, 450.
 Goerens, P., on metallography, 380.
 Gödel, P., book on metallurgy by, 450.
 Goldsmith, E., on meteorites, 241.
 Good, T., on iron trade statistics, 422.
 Goodenough, G. A., on strength of chain links, 391.
 Gowland, W., vote of thanks by, 22.
 Grabe, on determination of nitrogen in iron, 415.
 Gradenwitz, A., on Bavarian workmen's museum, 433.
 Gradenwitz, A., on blowing-engines, 313.
 Gradenwitz, A., on life-saving appliances, 304.
 Graham, A. J., on welding, 358.
 Graham, Robert, elected member, 2.
 Grahn, H., on methods of working coal, 294.
 Graphite, 252.
 Graphite and graphitic carbon in pig iron, 407.

- Graphite, destructive action of, on blast-furnace linings, 311.
Graphite in iron, solubility of, 406.
Graphite, production of, in the United States, 444.
Graphitic carbon in pig iron, 407.
Gray, H. E., on gases in mines, 299.
Great Britain, iron ore in, 230.
Greece, iron ore in, 232.
Greece, mineral statistics of, 434.
Green sand moulding, 329.
Greenawalt, W. E., on tungsten ore, 240.
Greene, A. E., on electric smelting of iron, 334.
Gregoretti, U., on armour-plates and projectiles, 370.
Greiner, L., on blast-furnace gases, 317.
Greiner, L., on coke-oven gases, 276.
Grey, Sir Edward, Bart., speech at dinner by, 190.
Gridley, Arnold Babb, elected member, 2.
Grimshaw, R., on clearing tapholes, 313.
Grimshaw, R., on manganese ore in Russia, 239.
Grimshaw, R., on recovery of iron from cupola slag, 328.
Griswold, W. T., on mineral statistics of the United States, 440.
Griswold, W. T., on natural gas in Pennsylvania, 285.
Griswold, W. T., on petroleum in Ohio, 281.
Groeck, H., on open-hearth steelworks in Germany, 361.
Grönwall, A., on special processes of electric smelting, 336.
Grossmann, J., on cast iron in the construction of chemical plant, 81.
Grout, F. F., on chemistry of coal, 258.
Gruhl, C., on methods of working coal, 295.
Grundy, J., on explosives and blasting, 243.
Guarini, E., book on mining by, 454.
Guillet, L., on manganese-iron alloys, 409.
Guillet, L., on metallography, 380.
Guillet, L., on nickel cast iron, 393.
Guillet, L., on tantalum steel, 409.
Guiselin, A., on uses of petroleum, 284.
Gulliver, G. H., on cohesion of steel, 379.
Gulliver, G. H., on permanent deformation of metals, 385.
Gürich, G., on coal in Germany, 260.
Gwyer, A. G. C., on iron-aluminium alloys, 409.

H.

- HAARMANN, A., on sleepers, 366.
Haas, J., on ferro-silicon, 404.
Haase, E., book on metallurgy by, 450.
Haberer, L., on mine surveying, 246.
Haberkalt, Karl, book on metallurgy by, 450.
Habets, A., on iron ore in Greece, 232.
Habets, Alfred, obituary notice of, 220.
Hache, book on mining by, 454.
Hachita, M. S., on life-saving appliances, 304.
Hachita, M. S., on methods of working coal, 295.
Hachita, M. S., on mine supports, 293.
Hachita, M. S., on underground fires, 302.
Hacquet, B., on petroleum in Austria, 277.
Hadfield, R. A., dinner to, 227.

- Hadfield, R. A., on new fatigue test for iron and steel, 63.
 Hadfield, R. A., speech at dinner by, 188.
 Haenig, A., on ores of the rare metals, 240.
 Haertter, J. H., on coal-screening, 306.
 Haldane, J. S., on compressed air at collieries, 292.
 Hall, A. I., on magnesite, 253.
 Hall, C., on coal in the United States, 443.
 Hall, C., on colliery explosions, 301.
 Hall, C., on gases in mines, 299.
 Halse, E., book on mining by, 454.
 Halstead, A., on peat, 270.
 Hamilton, N. D., on weathering of coal, 270.
 Hammer, E., on mine surveying, 246.
 Handling coal, 306.
 Handling iron ore, 247.
 Hanfstengel, G. von, book on metallurgy by, 450.
 Hann, E. M., on by-product coke-ovens, 273.
 Hansell, M. V., on iron ore dressing, 248.
 Harbord, F. W., biography of, 321.
 Harbord, F. W., on action of toothless circular saws, 390.
 Harbord, F. W., on cast iron in the construction of chemical plant, 77.
 Hardened steel, testing, 387.
 Hardened steels, constituents of, 388.
 Hardness of steel, 376.
 Harkort, H., on iron-tungsten alloys, 393.
 Harmet, H., on influence of gases on the structure of cast iron and steel, 378.
 Harriman, Norman F., elected member, 2.
 Harrington, B. J., on magnetite, 241.
 Harrison, George, obituary notice of, 214.
 Harrison, J. H., on improvements in plate rolling-mills, 40.
 Harrison, John William, elected member, 2.
 Harrison, L. H., on coal in New Zealand, 264.
 Hart, J., on weathering of coal, 270.
 Hart, John, obituary notice of, 215.
 Hart, J. F., on machine mauling, 321.
 Harvey, E. A., on producer-gas for power purposes, 286.
 Haslam, W. G., on cast iron in the construction of chemical plant, 82.
 Hassler, T. F. von, on iron ore in Austria, 232.
 Hatch, F. H., book on mining, 454.
 Hatfield, W. H., biography of, 321.
 Hatfield, W. H., on malleable castings, 330.
 Hatfield, W. H., on pyrometric installation in the Royal Gun and Carriage Factories, Woolwich, 134.
 Haulage, underground, 296.
 Haupt, E., on magnetic properties of iron and steel, 383.
 Häusser, F., on methods of gas analysis, 419.
 Haussmann, K., on deep boring, 242.
 Haworth, E., on petroleum in the United States, 444.
 Hayden, H. H., on graphite, 252.
 Heat treatment of steel, 357.
 Heathcote, H. L., on passivity of iron, 399.
 Heating, steam-boiler, 257.
 Hecker, P., on mine supports, 292.
 Hecks, J. H., on steel for structural purposes, 368.
 Hedberg, N., on lighting of mines, 246.
 Heess, J. K., book on metallurgy by, 450.
 Heil, A., on methods of working coal, 294.

- Heise, F., book on mining by, 454.
Hemingway, H., on cast iron in the construction of chemical plant, 82.
Henriques, Cecil Quixano, elected member, 2.
Herbst, F., book on mining by, 454.
Herland, H., on Chinese and Japanese foundries, 328.
Hermann, F., on metallography, 381.
Hermann, F., on theory of case-hardening, 386.
Herwegh, Camille, elected member, 3.
Herzog, S., book on metallurgy by, 450.
Hess, F. L., on mineral statistics of the United States, 440.
Heym, W., on gas-producers, 286.
Heyn, E., on metallography, 381.
Heyn, E., on structure of malleable iron, 379.
Hickman, Sir Alfred, Bart., biography of, 321.
High-speed steel, 361.
Hilgenstock, K., on mineral statistics of Prussia, 433.
Hill, B., on mineral statistics of the United States, 440.
Hill, Leonard, on life-saving appliances, 303.
Hinrichsen, F. W., on determination of phosphorus, 413.
Hirsch, C. O., on explosives in collieries, 301.
Hirschtaff, H., on producer-gas for power purposes, 287.
History of coal-mining, 304.
History of iron, 320.
History of iron ore mining, 248.
History of steel, 348.
Hobart, F., on iron trade statistics of the United States, 440.
Hochstrate, A., on methods of working coal, 294.
Hodges, Petronius, obituary notice of, 215.
Hofer, G., on decarburisation of iron, 332.
Hofer, G., on direct production of wrought iron, 332.
Hoffmann, F. L., on explosives in collieries, 301.
Hoffmann, G. C., on coal in Canada, 262.
Hoffmann, G. C., on dolomite, 254.
Hoffmann, G. C., on iron ore in Canada, 235.
Hoffmann, G. C., on native iron-nickel alloy, 241.
Holgate, T., on physico-chemical investigation of refractory materials, 251.
Holland, T. H., on coal in India, 261, 262.
Holland, T. H., on mineral statistics of India, 434.
Holmes, A. C., book on metallurgy by, 450.
Holmes, J. A., on gas-producers, 286.
Homén, L. B., on gas-producers, 286.
Honigl, J., on coal in Roumania, 261.
Hooghwinkel, G., on rolling-mill engines, 346.
Horne, James William, elected member, 3.
Hosie, Sir A., on mineral statistics of China, 426.
Howe, H. M., on segregation in steel ingots, 377.
Hoy, H. A., biography of, 321.
Hughes, H. W., on shaft-sinking, 290.
Humphrey, H. A., on gas-producers, 286.
Humphrey, R. L., on steel for structural purposes, 368.
Hungarian blast-furnaces, 319.
Hungarian Exhibition, 423.
Hungary, coal in, 261.
Hungary, manganese ore in, 239.
Hungary, mineral statistics of, 424.
Hungary, natural gas in, 284.
Hungary, petroleum in, 277.

- Hunter, David, elected member, 3.
 Hurmuzescu, D., on petroleum in Roumania, 278.
 Hutchinson, A., on meteorites, 241.
 Hutton, R. S., on direct union of carbon and hydrogen at high temperatures, 404.
 Hutton, R. S., on electric smelting of iron, 333.
 Hydrogen and carbon, direct union of, at high temperatures, 404.

I.

- IGEWSKY, B., *paper* on "A new type of electric furnace for the smelting of iron," 155 ; description of method of working with high-pressure electric current, 155 ; process of smelting, 161 ; advantages of the new type of furnace, 166.
 Illinois, coal in, 266.
 Impact testing, 386.
 Income and expenditure account, 16.
 India, coal in, 261.
 India, iron ore in, 235.
 India, manganese ore in, 239.
 Indian blast-furnaces, 319.
 Ingots, steel, segregation in, 377.
 Ireland, coal in, 259.
 Iron alloys used in the steel industry, 362.
 Iron-aluminium alloys, 409.
 Iron and steel, analysis of, 412.
 Iron and steel, cast, influence of gases on the structure of, 378.
 Iron and steel, corrosion of, 410.
 Iron and steel, further treatment of, 357.
 Iron and steel in Transvaal Colony, 439.
 Iron and steel, magnetic properties of, 383.
 Iron and steel, microstructure of, 379.
 Iron and steel, new fatigue test for, 54.
 Iron and steel, specifications for, 397.
 Iron-carbon alloys, influence of phosphorus on, 408.
 Iron-carbon system, theory of equilibrium in, 405.
 Iron-chromium alloys, 393.
 Iron, decarburisation of, 332.
 Iron, determination of, 416.
 Iron, determination of nitrogen in, 415.
 Iron, electric smelting of, 333.
 Iron, graphite in, solubility of, 406.
 Iron, history of, 320.
 Iron-molybdenum alloys, 409.
 Iron-nickel alloy, native, 241.
 Iron ore, briquetting, 249.
 Iron ore dressing, 248.
 Iron ore, handling, 247.
 Iron ore mines, electricity in, 245.
 Iron ore mining, 242.
 Iron ore transport, 247.
 Iron ore, world's production of, 446.
 Iron ores, 230.
 Iron ores and slag, analysis of, 416.
 Iron ores, occurrence and composition of, 230.
 Iron, passivity of, 399.

Iron, precipitation of, from pyrites, 411.
 Iron, recovery of, from cupola slag, 328.
 Iron, rusting of, 409.
 Iron salts, 404.
 Iron smelting, new type of electric furnace for, 155.
 Iron, specific heat of, 374.
 Iron-tungsten alloys, 393.
 Iron, world's production of, 446.
 Ironmaking in New South Wales, 423.
 Ironwork, Spanish, 372.
 Ironworks analysis, 412.
 Ironworks, Staveley, 318.
 Irresberger, C., on cupola practice, 325.
 Italian blast-furnaces, 319.
 Italy, coal in, 261.
 Italy, iron ore in, 232.
 Italy, petroleum in, 277.

J.

JACKSON, E., on cast iron in the construction of chemical plant, 82.
 Jamestown Exhibition, Virginia, mineral exhibits at, 444.
 Janitz, F., on manufacture of firebricks, 252.
 Japan, coal in, 269.
 Japan, mineral statistics of, 435.
 Japanese and Chinese foundries, 328.
 Joerchel, on underground haulage, 296.
 Johansson, H., on formation of ore deposits, 230.
 Johnson, A. A., on crucible tongs, 348.
 Johnson, Axel, biography of, 322.
 Johnson, B. L., on iron ore in Rhode Island, 238.
 Johnson, C. M., on determination of nickel, 415.
 Johnson, Philip Heber, elected member, 3.
 Johnston, J. M'A., on beehive coke-ovens, 273.
 Jones, H. O., on petroleum in Borneo, 282.
 Jordan, R., on gases in mines, 299.
 Jubilee of the Société de l'Industrie Minérale, 203.
 Junge, F. E., book on metallurgy by, 450.
 Junge, F. E., on blast-furnace gases, 315.
 Junge, F. E., on gas-engines, 288.
 Junge, F. E., on gas-producers, 286.
 Jüngst, E., on mineral statistics of Germany, 431.
 Jüngst, F., book on mining by, 454.
 Jüngst, O., on coal-cutting machinery, 292.

K.

KAHN, M., on reinforced concrete, 369.
 Kapaun, F., on formation of cracks in plates, 388.
 Kapeller, F., on iron salts, 404.
 Karman, T. von, on bending tests, 386.
 Katzer, F., on coal in Bosnia, 260.
 Kayser, on water-gas, 287.
 Kayser, A., on mineral statistics of Germany, 432.
 Keep, W. J., on cupola practice, 325.

- Keep, W. J., on foundry mixtures, 326.
 Kegel, K., on mine ventilation, 299.
 Kegel, K., on subsidence, 304.
 Kellner, F., on beehive coke-ovens, 272.
 Kempson, J. F., on cast iron in the construction of chemical plant, 83.
 Kendall, P. F., on coal in the Midlands, 259.
 Kentucky, coal in, 266.
 Kerdyk, F., on microstructure of iron and steel, 379.
 Kershaw, J. B. C., on electric furnaces for foundry work, 327.
 Kershaw, J. B. C., on electric smelting of iron, 333.
 Ketner, C. H., on determination of phosphoric acid, 416.
 King, Ernest Gerald, elected member, 3.
 King, Tom Cobb, obituary notice of, 215.
 Kirkby, R., on search for coal, 290.
 Kirschke, A., book on metallurgy by, 450.
 Kirsopp, John, jun., book on mining by, 454.
 Kjellberg, J. C., biography of, 323.
 Klarfeld, H., on origin of petroleum, 277.
 Klebert, on boring for petroleum, 284.
 Klein, G., book on mining by, 455.
 Kleinschmidt, C., on methods of working coal, 294.
 Knapmann, K., on history of iron, 321.
 Knight, C. W., on petroleum in Canada, 279.
 Knight, Nicholas, on determination of iron, 416.
 Koch, W. E., on small Bessemer plant, 355.
 Koerner, G., on deep boring, 242.
 Koert, W., on iron ore in Togo, 239.
 Koninck, L. L. de, on determination of carbon, 412.
 Konrad, H., on iron trade statistics of France, 431.
 Körmann, F., on gas-engines, 289.
 Körting, E., on beehive coke-ovens, 272.
 Körting, E., on by-product coke-ovens, 274.
 Kralupper, M., on armour-plates and projectiles, 370.
 Krämer, G., on origin of petroleum, 277.
 Kraus, J., on machine moulding, 329.
 Krause, C., book on mining by, 455.
 Kulka, E., on underground haulage, 297.
 Kutzbach, K., on blast-furnace gases, 317.

L.

- LAKE, E. F., on alloys used in the steel industry, 365.
 Lake, E. F., on heat treatment of steel, 357.
 Lake Superior, iron ore on, 237.
 Lakes, A., on coal in Canada, 263.
 Lakes, A., on coal in Colorado, 266.
 Lamb, H. M., on iron ore in Canada, 235.
 Lamb, H. M., on mineral statistics of Canada, 426.
 Lambert, Wesley, *paper* on "The pyrometric installation in the Gun Section, Royal Gun and Carriage Factories, Woolwich," 109; introduction, 109; previous attempts to control temperatures pyrometrically, 110; description of instruments and system employed in the Gun Department, 111; appendix, 130.—*Discussion*: Sir T. Wrightson, Bart., 132; W. Rosenhain, 132; J. M. Gledhill, 132; C. Benedicks, 134; W. H. Hatfield, 134; T. Turner (Birmingham), 134.—*Correspondence*: E. F. Law, 135; Wesley Lambert, 136.

- Lambert, W. J., on testing-machines, 395.
- Lamberton, Andrew, *paper* on "Improvements in plate rolling-mills," 30; progress in the manufacture of steel plates, 30; conditions imposed on the rolling of thin plates, 31; American practice, 31; advantages possessed by the two-high reversing-mill, 32; description of new form of plate-mill at Glasgow Iron and Steel Works, Wishaw, 33; consideration of the claims made for the new form of mill, 34.—*Discussion*: J. Riley, 39; J. H. Harrison, 40; J. M. Gledhill, 41; P. N. Cunningham, 42; H. Crowe, 44; E. J. Duff, 45; A. Lamberton, 46, 51; Sir Hugh Bell, Bart., 48.—*Correspondence*: F. Finlayson, 49; O. C. Morgan, 50; F. W. Paul, 50.
- Lancashire, coal in, 259.
- Lane, H. M., on foundry mixtures, 326.
- Lane, H. M., on physical properties of cast iron, 386.
- Langer, P., on blowing-engines, 313.
- Lantsberry, Fred. C. A. H., elected member, 3.
- Large castings, 330.
- Lathe, F. E., on open-hearth steel works in Canada, 351.
- Lauth, B. C., on duplex steel-making process, 365.
- Lautsch, on iron-molybdenum alloys, 409.
- Law, Edward Fulton, elected member, 3.
- Law, E. F., *paper* on "Application of colour photography to metallography," 151.—*Discussion*: J. E. Stead, 153; Sir Hugh Bell, Bart., 153.—*Correspondence*: T. Middleton, 153; E. F. Law, 154.
- Law, E. F., on pyrometric installation in the Royal Factories, Woolwich, 135.
- Leach, W. W., on coal in Canada, 263.
- Le Chatelier, H., on graphite, 253.
- Lecomte-Denis, M., book on mining by, 455.
- Ledebur, A., book on metallurgy by, 450.
- Lederer, Arthur, book on metallurgy by, 450.
- Lee, W. T., on coal in the United States, 265.
- Lee, W. T., on coal in Utah, 267.
- Legge, T. M., on dangerous processes in tinning, 372.
- Lemmy, George Kingsford, elected member, 3.
- Lennox, L. C., on titaniferous slags, 323.
- Lentz, Arthur, elected member, 3.
- Leonard, A. G., on coal in Montana, 267.
- Le Roy, G. A., on asphalt, 282.
- Le Tall, Sydney Harold, elected member, 3.
- Lewis, J. Dyer, on colliery explosions, 300.
- Lewitinski, A. S., on magnetic separators, 219.
- Lewkowitsch, J., on origin of petroleum, 277.
- Library, additions to, 222.
- Lichte, H. F., on forging presses, 341.
- Life-saving appliances, 303.
- Lighting of collieries, 302.
- Lighting of mines, 246.
- Lilienberg, N., on compression of steel ingots, 360.
- Limbourg, F., on blast-furnace gases, 314.
- Lime-alumina-silica mixtures, fusibility of, 323.
- Lind, S. C., on determination of tungsten, 414.
- Lindgren, Waldemar, on tungsten ore, 240.
- Lines, E. F., on coal in Pennsylvania, 267.
- Liquid fuel, 276.
- Ljungberg, E. J., vote of thanks by, 29.
- Load for railway bridges, 369.
- Lord, N. W., on coal analysis, 417.
- Louis, H., on methods of working coal, 294.

- Louis, H., on nomenclature of ore deposits, 230.
 Louis, H., on shaft-sinking, 290.
 Lucke, C. E., on gas-producers, 286.
 Ludwik, P., book on metallurgy by, 450.
 Luhr, F., on rolling-mill engines, 346.
 Lunge, G., on cast iron in the construction of chemical plant, 83.
 Lunt, Reginald Lacey, elected member, 3.
 Lürmann, F. W., on cupola practice, 325.
 Lürmann, F. W., on improvements in blast-furnace practice, 308.
 Luty, B. E. V., on American blast-furnaces, 320.

M.

- M'FARLANE, W., on Indian blast-furnaces, 319.
 Macfarlane, W., on the metallurgical and chemical laboratories of the National Physical Laboratory, 108.
 Macfarren, W. W., on beehive coke-ovens, 272.
 MacGregor, F. S., on electric smelting of iron, 334.
 Machine-cast and sand-cast pig iron for foundry work, 327.
 Machine moulding, 329.
 M'Lain, D., on semi-steel castings, 330.
 Maclaren, John Finlay, obituary notice of, 215.
 MacLaurin, J., on coal in New Zealand, 264.
 M'Leish, J., on mineral statistics of Canada, 426.
 McMechen, F. L., book on metallurgy by, 450.
 McNeill, Bedford, book on mining by, 456.
 Magnesia, determination of, 417.
 Magnesite, 253.
 Magnetic properties of iron and steel, 383.
 Magnetic separators, 249.
 Magnetite, 241.
 Magnin, J., on oil shale in France, 283.
 Magri, G., on determination of iron, 416.
 Maleyka, K., on electricity in rolling-mills, 344.
 Malleable castings, 330.
 Malleable iron, carburisation of, 348.
 Malleable iron, production of, 332.
 Malleable iron, structure of, 379.
 Mamy, H., on machine moulding, 329.
 Manganese, determination of, 412.
 Manganese-iron alloys, 409.
 Marchis, L., book on metallurgy by, 451.
 Marcusson, J., on origin of petroleum, 277.
 Markham, E. R., on pyrometry, 257.
 Markus, J., on petroleum in Italy, 277.
 Marshall, F. D., on by-product coke-ovens, 275.
 Martell, P., on history of iron, 321.
 Martell, P., on mineral statistics of Hungary, 425.
 Martens, A., on elastic properties of steel, 396.
 Martens, A., on testing-machines, 395.
 Mashek, G. J., on briquette manufacture, 307.
 Mason, C. W., on machine-cast and sand-cast pig iron for foundry work, 327.
 Matschoss, C., book on metallurgy by, 451.
 Matthews, E. R., on reinforced concrete, 369.
 Mauzelius, R., on determination of iron, 416.

- Mayer, E. W., on determination of manganese, 412.
Mayrhofer, Josef, on determination of magnesia, 417.
Mechanical preparation, 248.
Mechanical treatment of steel, physical qualities in relation to, 167.
Medals and research scholarships, 13.
Mees, G., on blast-furnace gases, 317.
Mehner, H., on manufacture of firebricks, 252.
Mehrtens, J. H., on smoke abatement, 258.
Merrill, G. P., on meteorites, 242.
Metal mining, problems in, 247.
Metallic moulds, casting iron in, 329.
Metallography, 380.
Metallography, application of colour photography to, 151.
Metallurgical and chemical laboratories in the National Physical Laboratory, 87.
Metallurgical Congress at St. Etienne, 203.
Metallurgical education in Germany, 433.
Metallurgical preparation, 250.
Metallurgy of tungsten, early, 411.
Metals, permanent deformation of, 385.
Meteorites, recent researches on, 241.
Methods of working coal, 298.
Methods of working iron ore, 244.
Meunier, L., elected member, 3.
Mexico, iron ore in, 239.
Meyer, E., on bending tests, 386.
Meyer, E., on hardness of steel, 376.
Michael, R., on coal in Germany, 260.
Michael, R., on manganese ore in Spain, 239.
Michenfelder, C., on foundry appliances, 326.
Michenfelder, C., on steelworks equipment, 352.
Michigan, coal in, 266.
Microstructure of iron and steel, 379.
Middleton, T., on application of colour photography to metallography, 153.
Middleton, T., on new fatigue test for iron and steel, 67.
Midlands, coal in, 259.
Millosevich, F., on iron ore in Italy, 232.
Mine drainage, 245, 298.
Mine supports, 292.
Mine surveying, 246.
Mine ventilation, 299.
Mineral statistics, comparative, 446.
Mines and quarries, accidents in, in the United Kingdom, 423.
Mines, compressed air in, 243.
Mines, gases in, 299.
Mines, lighting of, 246.
Mingaye, J. H. C., on coal in Japan, 269.
Mining and Metallurgical Congress at St. Etienne, 203.
Mining, economics of, 247, 304.
Mining, history of, 248.
Mining, iron ore, 242.
Mining law of Bulgaria, 425.
Minnesota, iron ore in, 238.
Mitchell, P. J., on blowing-engines, 314.
Moisture, determination of, 418.
Moldenke, R., on specifications for iron and steel, 397.
Molo, W. R. von, on special processes of electric smelting, 336.
Monnot, J. F., on duplex metal, 372.

- Montana, coal in, 266.
 Monypenny, John Henry Gill, elected member, 3.
 Moore, E. S., on iron ore in Canada, 234.
 Moore, L. E., on strength of chain links, 391.
 Morgan, O. C., on improvements in plate rolling-mills, 50.
 Morgan, O. C., on new fatigue test for iron and steel, 68.
 Morgan, T. D., on history of iron, 321.
 Morin, on shaft-sinking, 290.
 Morrison, C. E., on mine surveying, 246.
 Morrow, John, on shaft-sinking, 290.
 Moss, R. S., on colliery explosions, 300.
 Mossberg, E., on rock-drills, 243.
 Mosscrop, Alfred Mitton, elected member, 3.
 Motor-cars, steel for, 366.
 Moulding, green sand, 329.
 Moulding, machine, 329.
 Moulding sand, 328.
 Moulds, metallic, casting iron in, 329.
 Mowbray, Archibald John Holme, elected member, 3.
 Mowley, M., on economics of mining, 304.
 Müller, C., on history of coal-mining, 304.
 Müller, C. E., & Co., Ltd., on iron ore in the United Kingdom, 422.
 Müller, C. E., & Co., Ltd., on iron trade statistics of Sweden, 438.
 Müller, E., on iron-salts, 404.
 Müllner, A., book on metallurgy by, 451.
 Müllner, A., on history of iron, 321.
 Müllner, A., on petroleum in Austria, 277.
 Mumford, E. H., on machine-moulding, 329.
 Munich, German museum at, 433.
 Munn, M. J., on natural gas in Pennsylvania, 285.
 Munn, M. J., on petroleum in Ohio, 281.
 Murdoch, W. H. F., on magnetic properties of iron and steel, 383.
 Murgoci, G., on coal in Roumania, 261.
 Murray, R. A. F., on coal in Victoria, 264.
 Mussan, C. de, book on metallurgy by, 451.
 Myres, J. L., on history of iron, 320.
 Mysore, iron ore in, 434.

N.

- NÄGEL, O., on gas-producers, 286.
 Nägel, O., on producer-gas for power purposes, 287.
 Nani, Elconide, elected member, 3.
 Naske, T., on steelworks in Austria, 350.
 Natal, iron ore in, 236.
 Natal, mineral statistics of, 435.
 National Physical Laboratory, 397.
 National Physical Laboratory, collected researches, 451.
 National Physical Laboratory, metallurgical and chemical laboratories in, 87.
 Native iron, 241.
 Native iron-nickel alloy, 241.
 Natural gas, 284.
 Nauckhoff, S., on explosives and blasting, 243.
 Neal, J., on colliery explosions, 301.
 Needham, Joseph George, elected member, 3.
 Needles, 372.

- Neill, J. S., book on mining by, 455.
Neuburger, A., book on metallurgy by, 451.
Neuman, Viktor von, elected member, 3.
Neumann, B., on determination of carbon, 412.
Neumann, B., on ferro-silicon, 404.
New Caledonia, nickel ore in, 240.
Newland, D. H., on iron ore in the Adirondack Region, 238.
New Mexico, coal in, 267.
New South Wales, coal in, 263.
New South Wales, ironmaking in, 423.
New South Wales, manganese ore in, 240.
New South Wales, oil shale in, 233.
New Zealand, coal in, 264.
New Zealand, iron ore in, 236.
New Zealand, mineral statistics of, 424.
Nickel cast iron, 393.
Nickel, determination of, 414.
Nickel ore in New Caledonia, 240.
Nickel plate, impure, 411.
Nickles, J. M., on coal in the United States, 265.
Nicolardot, P., book on metallurgy by, 451.
Nicolardot, P., on early metallurgy of tungsten, 411.
Nisser, Carl Martin, elected member, 3.
Nitrogen in iron, determination of, 415.
Nomenclature of ore deposits, 230.
Nomura, Iwao, elected member, 3.
Norman, F., on underground haulage, 296.
Norris, R. V., on mine supports, 233.
Norway, iron ore in, 232.
Norway, mineral statistics of, 435.
Notation, standard, 397.
Noth, J., on petroleum in Austria, 277.
Nyassaland, iron ore in, 237.

O.

- OBERHOFFER, P., on specific heat of iron, 374.
Obituary notices, 209.
Occurrence and composition of iron ores, 230.
Oehlert, M., on iron ore in France, 232.
Offices, new, of the Iron and Steel Institute, 198.
Ohio, petroleum in, 281.
Oil shale in France, 283.
Oil shale in New South Wales, 283.
Oliver, T., book on mining by, 455.
Open-hearth and Bessemer processes, comparison of, 355.
Open-hearth process, 349.
Open-hearth steel plant, new, 349.
Open-hearth steelworks in Canada, 351.
Open-hearth steelworks in Germany, 351.
Open-hearth steelworks in the United States, 352.
Orange River Colony, mineral statistics of, 436.
Ordnance, 371.
Ore deposits, formation of, 230.
Ore deposits, nomenclature of, 230.
Ores of the rare metals, 240.

Origin of petroleum, 276.
 Orthey, M., on chemistry in the foundry, 327.
 Orthey, M., on determination of carbon, 412.
 Osann, B., on destructive action of graphite on blast-furnace linings, 311.
 Osann, B., on scaffolding at blast-furnaces, 311.
 Osiceanu, C., on mineral statistics of Roumania, 436.
 Ost, H., on smoke abatement, 258.
 Ottermann, H., on coal in Germany, 260.
 Outerbridge, A. E., on moulding sand, 323.
 Ovens, drying, 330.

P.

PAGE, E. P., on utilisation of fireclays, 251.
 Parcoret, E., book on metallurgy by, 461.
 Parker, E. W., on briquette manufacture, 307.
 Parker, E. W., on coal in the United States, 443.
 Parker, E. W., on mineral statistics of the United States, 440.
 Parker, Sidney S., elected member, 3.
 Parmelee, H. C., on determination of silica, 416.
 Parr, S. W., on weathering of coal, 270.
 Parsons, F. W., on coal-handling, 306.
 Parsons, F. W., on coal in Montana, 266.
 Parsons, F. W., on coal in Virginia, 267.
 Parsons, F. W., on coal in Wyoming, 268.
 Parsons, F. W., on colliery explosions, 300, 301.
 Parsons, F. W., on methods of working coal, 295.
 Parsons, F. W., on underground haulage, 296.
 Pascal, P., on iron salts, 404.
 Passivity of iron, 399.
 Patchell, W. H., on steam-boiler heating, 258.
 Paterno, E., book on metallurgy by, 448.
 Paul, F. W., on cast iron in the construction of chemical plant, 78.
 Paul, F. W., on improvements in plate rolling-mills, 50.
 Pavlov, M. A., on fusibility of lime-alumina-silica mixtures, 323.
 Peasegood, W. G., on petroleum in Scotland, 277.
 Peat, 269.
 Peat-coke, 276.
 Peat, James Barclay, elected member, 3.
 Pennsylvania, coal in, 267.
 Pennsylvania, natural gas in, 285.
 Pennsylvania, petroleum in, 281.
 Permanent deformation of metals, 385.
 Peru, coal in, 269.
 Peru, iron ore in, 239.
 Peru, petroleum in, 282.
 Petavel, J. E., on electric smelting of iron, 333.
 Peter, on forging presses, 341.
 Petersson, W., on iron ore in Sweden, 233.
 Petrón, on determination of nitrogen in iron, 415.
 Petroff, W., on magnetic separators, 249.
 Petroleum analysis, 418.
 Petroleum, boring for, 284.
 Petroleum Congress, 282.
 Petroleum in the United States, 444.
 Petroleum, origin of, 276.

- Petroleum, uses of, 284.
Pfaff, F. W., on dolomite, 254.
Pfeifer, J., on methods of gas analysis, 419.
Pfeifer, J., on natural gas in Hungary, 284.
Phalen, W. C., on coal in Pennsylvania, 267.
Phillips, A. S., on briquette manufacture, 306.
Phosphatic chalk for blast-furnace use, 312.
Phosphoric acids, determination of, 416.
Phosphorus, determination of, 413.
Phosphorus, influence of, on iron-carbon alloys, 408.
Phosphorus, sources of error in the determination of, 413.
Photography, colour, application of, to metallography, 151.
Physical properties, 374.
Physical properties of cast iron, 385.
Physical qualities of steel in relation to its mechanical treatment, 167.
Physico-chemical investigation of refractory materials, 251.
Pickling of steel, electrolytic, 372.
Pietrkowski, A., on iron ore transport, 217.
Pietrusky, A., on uses of petroleum, 284.
Pig iron analyses, 322.
Pig iron, Brazilian, 323.
Pig iron, chemical composition of, 322.
Pig iron, German analyses of, 322.
Pig iron, graphite and graphitic carbon in, 407.
Pig iron, machine-cast, for foundry work, 327.
Pig iron, production of, 308.
Pig iron, sand-cast, for foundry work, 327.
Pig iron, Würtemberg, 323.
Pila, H., book on metallurgy by, 451.
Pinegin, W., on physical properties of cast iron, 386.
Pipes, cast iron, 331.
Pit-head frames, 298.
Plate rolling-mills, improvements in, 30.
Plates, formation of cracks, 388.
Player, H., on calorimetry, 256.
Plotenyi, G., on history of mining, 248.
Plotenyi, G., on mine surveying, 246.
Poni, P., on petroleum in Roumania, 278.
Ponti, Alberto delli, elected member, 3.
Porn, M., on uses of petroleum, 284.
Porter, J. J., on improvements in blast-furnace practice, 309.
Porter, J. J., on zinc in the blast-furnace, 312.
Portevin, A. M., on solidification points and transformation in alloys, 381.
Portevin, A. M., on theory of equilibrium in the iron-carbon system, 405.
Portland and blast-furnace cement, 324.
Portugal, petroleum in, 278.
Portuguese colonies, manganese ore in, 240.
Porucic, T., on mineral statistics of Roumania, 436.
Post, J. W., on sleepers, 365.
Post van der Burg, Hendrik, obituary notice of, 216.
Postuvanschitz, Fritz, book on metallurgy by, 450.
Potter, H. N., on calorimetry, 266.
Power purposes, producer-gas for, 286.
Pozzi-Escot, E., on determination of nickel, 414.
Pratt, Dudley H., elected member, 4.
Prece, G. G. L., on electricity in collieries, 291.
Premises, new, of the Iron and Steel Institute, 198.

- President. *See* Bell, Sir Hugh.
 Prest, J. J., on shaft-sinking, 290.
 Preuss, E., award of Carnegie Scholarship to, 26.
 Primrose, John Stewart Glen, elected member, 4.
 Pring, J. N., on direct union of carbon and hydrogen at high temperatures, 404.
 Problems in metal mining, 247.
 Probst, E., on reinforced concrete, 370.
 Producer-gas for power purposes, 286.
 Production of malleable iron, 332.
 Production of pig iron, 308.
 Production of steel, 348.
 Projectiles and armour-plates, 370.
 Prost, E., on coal-washing, 305.
 Prussia, mineral statistics of, 432.
 Prussia, provident funds in, 434.
 Puddling furnace, Danks, 333.
 Purdy, R. C., on fireclay, 251.
 Purifying boiler feed-water, 313.
 Putnam, Arthur, elected member, 4.
 Pütz, O., book on mining by, 455.
 Pütz, O., on iron ore in Spain, 233.
 Pyrites, precipitation of iron from, 411.
 Pyrometric installation in the Gun Section, Royal Gun and Carriage Factories,
 Woolwich, 109.
 Pyrometry, 256.

Q.

- QUALITY of steel masses, improvement of, 359.
 Queensland, petroleum in, 279.
 Queiroz, J. J. de, on Brazilian pig iron, 323.

R.

- RABIUS, W., on by-product coke-ovens, 275.
 Radcliffe, William, obituary notice of, 215.
 Ragno, S., book on metallurgy by, 451.
 Rails, 365, 391.
 Rails, tramway, corrugation of, 392.
 Railway bridges, load for, 389.
 Rakoczy, Samuel, on history of mining, 248.
 Rakusin, M. A., on origin of petroleum, 277.
 Rakusin, M. A., on petroleum in Russia, 279.
 Randolph, B. S., on silica sand, 251.
 Rateau, A., book on mining by, 455.
 Rare metals, ores of, 240.
 Rason, C. H., on coal in Western Australia, 264.
 Rawles, W. H., on calorimetry, 255.
 Raymond, E., on determination of manganese, 413.
 Recalescence curves, 384.
 Redlich, K. A., book on mining by, 455.
 Redlich, K. A., on iron ore in Austria, 231.
 Redlich, K. A., on magnesite, 253.
 Redmayne, R. A. S., on winding appliances, 298.
 Reed, C. J., on electrolytic pickling of steel, 372.
 Refractory materials, 251.

- Refractory materials, physico-chemical investigation of, 251.
 Reike, R., on fusibility of lime-alumina-silica mixtures, 323.
 Reinforced concrete, 369, 396.
 Reinhard, M., on origin of petroleum, 277.
 Reischle, J., on welding, 358.
 Renier, A., on coal in Belgium, 260.
 Report of Council, 5.
 Report of Treasurer, 18.
 Representatives, appointment of, 14.
 Retiring members of Council, 15.
 Reumaux, E., on mineral statistics of France, 430.
 Révillon, L. P. M., award of Carnegie Scholarship to, 26.
 Révillon, L. P. M., on steel for motor-cars, 366.
 Rez, G., on petroleum in Hungary, 277.
 Rhode Island, iron ore in, 238.
 Richards, A. W., on new fatigue test for iron and steel, 64.
 Richards, Frank, on steam-hammers, 341.
 Richards, J. W., on electric smelting of iron, 333.
 Richardson, G. B., on coal in Colorado, 266.
 Riches, T. Hurry, biography of, 321.
 Richmond, Sir David, obituary notice of, 216.
 Richter, R., on methods of working iron ore, 244.
 Rickard, T. A., book on mining by, 455.
 Rider, James, jun., elected member, 4.
 Ridge, Harry Mackenzie, elected member, 4.
 Ridley, Viscount, speech at dinner by, 188.
 Ridsdale, C. H., biography of, 321.
 Ridsdale, C. H., on improvements in blast-furnace practice, 309.
 Rietkötter, G., on annealing furnaces, 357.
 Rietkötter, Karl, on winding, 245.
 Riley, J., on improvements in plate rolling-mills, 39.
 Ritter, E. A., book on mining by, 455.
 Roberty, K., book on mining by, 455.
 Roberty, K., on iron ore in Tunis, 238.
 Robinson, C. N., on armour-plates and projectiles, 370.
 Robinson, J. V., on blast-furnace gases, 314.
 Robinson, J. V., on gas-cleaning, 318.
 Robinson, W. B., on cast iron pipes, 331.
 Rock-drills, 243.
 Rohland, D. P., on fireclays, 251.
 Rohland, P., on reinforced concrete, 370.
 Roll of the Institute, 5.
 Rolling-mill engines, 346.
 Rolling-mill scale, 346.
 Rolling-mills, 344.
 Rolling-mills, electricity in, 342.
 Rolling-mills, plate, improvements in, 30.
 Roscoe, Sir H. E., book on metallurgy by, 451.
 Rosenhain, W., on crystallisation of steel, 378.
 Rosenhain, W., *paper* on "The Metallurgical and Chemical Laboratories in the National Physical Laboratory," 87; description of the laboratories, 87; description of the methods of determining carbon, phosphorus, and sulphur, 96.—*Discussion*: W. Rosenhain, 107; Sir Hugh Bell, 107.—*Correspondence*: W. Macfarlane, 108.
 Rosenhain, W., on pyrometric installation in the Royal Gun and Carriage Factories, Woolwich, 132.
 Rosenhain, W., on recalescence curves, 384.
 Rosenhain, W., on workshop treatment of steel, 361.

- Rosenkranz, M., on briquette manufacture, 307.
 Rosenstein, M., on determination of nickel, 414.
 Ross, A. C., on petroleum in the Argentine Republic, 282.
 Rössle, K., book on metallurgy by, 451.
 Rost, F., book on mining by, 455.
 Rothenbach, W., on calorimetry, 256.
 Roumania, coal in, 261.
 Roumania, mineral statistics of, 436.
 Roumania, petroleum in, 278.
 Routledge, W., on winding appliances, 298.
 Rowan, F. J., on gas-producers, 286.
 Royal Gun and Carriage Factories, Woolwich, pyrometric installation in the Gun Section, 109.
 Rummel, K., on blowing-engines, 313.
 Runciman, Sir Walter, Bart., speech at dinner by, 187.
 Russia, coal in, 261.
 Russia, iron ore in, 233.
 Russia, iron trade statistics of, 436.
 Russia, manganese ore in, 239.
 Russia, natural gas in, 284.
 Russia, petroleum in, 278.
 Rusting of iron, 409.

S.

- SACERDOTI, L., on determination of manganese, 413.
 Saghalien, Island of, coal in, 268.
 Sahara, coal in, 269.
 Sahlin, Carl, on mineral statistics of Sweden, 438.
 Sahmen, R., on copper-iron alloys, 409.
 Sahulka, J., on magnetic properties of iron and steel, 383.
 St. Etienne, Mining and Metallurgical Congress at, 203.
 Saliger, R., book on metallurgy by, 451.
 Sallows, J. F., book on metallurgy by, 451.
 Sampling coal, 270.
 Samter, Victor, on automatic gas analysis, 420.
 Sand-cast pig iron for foundry work, 327.
 Sand, moulding, 328.
 Sandberg, C., on petroleum in South Africa, 279.
 Sandberg, C. P., on new fatigue test for iron and steel, 68.
 Saniter, E. H., on new fatigue test for iron and steel, 65.
 Sankey, H. Riall, on bending tests, 386.
 Saunders, W. L., on rock-drills, 243.
 Saws, toothless circular, action of, 390.
 Saxony, mineral production of, 433.
 Scaffolding at blast-furnaces, 310.
 Schaeffers, Joseph, on steel for motor-cars, 366.
 Scharowsky, C., book on metallurgy by, 451.
 Schick, L., on petroleum in Roumania, 278.
 Schindler, Karl, book on metallurgy by, 451.
 Schindler, S. M., on case-hardening, 179.
 Schleicher, A., on rusting of iron, 410.
 Schlomann, A., book on metallurgy by, 449.
 Schmid, A., on special processes of electric smelting, 338.
 Schmidhammer, W., on blast-furnace gases, 317.
 Schmidt, C., on asphalt, 282.

- Schmidt, Otto S., on cupola practice, 325.
 Scholze, K., on explosives and blasting, 243.
 Schömburg, W., book on metallurgy by, 452.
 Schömburg, W., on rolling-mill engines, 346.
 Schöngut, Joseph, elected member, 4.
 Schontheil, T., on life-saving appliances, 303.
 Schorlemmer, C., book on metallurgy by, 451.
 Schorrig, E., book on mining by, 455.
 Schreiber, K., on winding appliances, 298.
 Schultz, A. R., on coal in Wyoming, 263.
 Schultz, G., on rusting of iron, 410.
 Schulz, C., on colliery explosions, 300.
 Schulze, H., on welding, 358.
 Schwarz, C. de, *paper* on "Utilisation of blast-furnace slag," 137; manufacture of bricks from slag, 137; advantages of slag bricks over ordinary bricks, 140; manufacture of cement from slag, 141; description of improved apparatus for the manufacture of cement, 144; description of Mumford & Moodie's ball-mill for grinding slag, 146; conclusions, 149.—*Correspondence*: J. W. Brough, 149; C. de Schwarz, 150.
 Schwarz, P., book on mining by, 455.
 Scotland, petroleum in, 277.
 Scott, E. Kilburn, on magnesite, 253.
 Scottish National Exhibition, 423.
 Screening coal, 305.
 Search for coal, 290.
 Searston, J., on underground haulage, 296.
 Segregation in steel ingots, 377.
 Selbach, K., on explosives in collieries, 291.
 Semi-steel castings, 330.
 Separators, magnetic, 249.
 Servia, mineral statistics of, 437.
 Sewell, J. S., on steel for structural purposes, 368.
 Shaft-sinking, 242, 290.
 Shaler, M. K., on coal in New Mexico, 267.
 Shamel, C. H., book on mining by, 455.
 Shaw, W. B., on electricity in collieries, 291.
 Shaw Scott, G., on case-hardening, 182.
 Shaw Scott, Gilbert, elected member, 4.
 Sheldon, S. B., on by-product coke-ovens, 274.
 Shipbuilding in the United Kingdom, 423.
 Shore, A. F., on hardness of steel, 376.
 Shurick, A. T., on coal in Wyoming, 268.
 Shurick, A. T., on methods of working coal, 295.
 Siebenthal, C. E., on coal in Wyoming, 268.
 Sieverts, A., on occluded gases in steel, 403.
 Silica, determination of, 416.
 Silica sand, 251.
 Simmons, Charles, elected member, 4.
 Simonis, M., on physico-chemical investigation of refractory materials, 251.
 Simpson, E. S., on iron ore in Western Australia, 235.
 Singer, L., on petroleum analysis, 418.
 Sjögren, H., on iron ore in Sweden, 234.
 Sjövall, B., on blowing-engines, 314.
 Slag in cast steel, composition of, 405.
 Slags, blast-furnace, 323.
 Slags, blast-furnace, bricks from, 324.
 Slags, titaniferous, 323.
 Sleepers, 365.

- Slevin, P. J., on explosives in collieries, 301.
 Slocum, C. V., on ferro-titanium, 394.
 Smelting, electric, special processes of, 336.
 Smelting of iron, new type of electric furnace for, 155.
 Smet, W. de, on methods of gas analysis, 419.
 Smith, Alexander, on history of coal-mining, 304.
 Smith, C. W., on steel for structural purposes, 369.
 Smith, George Edward, elected member, 4.
 Smith, G. O., on mine surveying, 247.
 Smith, G. O., on mineral statistics of the United States, 440.
 Smith, H. Procter, on producer-gas for power purposes, 287.
 Smith-Casson, Richard, obituary notice of, 217.
 Smoke abatement, 258.
 Snelling, W. O., on coal in the United States, 443.
 Snow, W. B., on cupola blowers, 325.
 Société de l'Industrie Minérale, celebration of the jubilee of, 203.
 Solberg, Carl Nicolai Andreas, obituary notice of, 217.
 Solidification points and transformation in alloys, 381.
 Solovieff, A., on crucible steel, 348.
 Sondermann, F., book on metallurgy by, 452.
 Sorby, Henry Clifton, obituary notice of, 217.
 Soulé, F., on steel for structural purposes, 368.
 South Africa, petroleum in, 279.
 South Australia, mineral statistics of, 424.
 Spain, iron ore in, 233.
 Spain, iron trade statistics of, 437.
 Spain, manganese ore in, 230.
 Spanish ironwork, 372.
 Special processes of electric smelting, 336.
 Specific heat of iron, 374.
 Specifications for iron and steel, 397.
 Spielmann, F., book on metallurgy by, 452.
 Standard notation, 397.
 Stansbie, J. H., book on metallurgy by, 452.
 Stansfield, A., book on metallurgy by, 452.
 Stansfield, A., on electric smelting of iron, 333.
 Stanton, T. E., *paper* on "A new fatigue test for iron and steel," 54; description of machine, 55; behaviour of specimen under test, 57; materials on which fatigue tests have been made, 58; results of experiments, 59.—*Discussion*: J. M. Gledhill, 63; R. A. Hadfield, 63; A. W. Richards, 64; E. H. Saniter, 65; W. R. Webster, 66; T. E. Stanton, 66.—*Correspondence*: T. Middleton, 67; O. C. Morgan, 68; C. P. Sandberg, 68; T. E. Stanton, 69.
 Stassart, S., on colliery explosions, 300.
 Statistics, 421.
 Staveley ironworks, 318.
 Stead, J. E., on application of colour photography to metallography, 163.
 Stead, J. E., on cast iron in the construction of chemical plant, 77.
 Steam-boiler heating, 257.
 Steam-hammers, 341.
 Steck, Ernst Hugo, elected member, 4.
 Steel, cast, composition of slag in, 405.
 Steel, cast iron and, influence of gases on the structure of, 378.
 Steel castings, 361.
 Steel, cohesion of, 379.
 Steel converter, Wills, 353.
 Steel crystallisation of, 378.
 Steel, diamond and carborundum crystals in, 404.

- Steel, elastic properties of, 395.
Steel, electrolytic pickling of, 372.
Steel for motor-cars, 366.
Steel for structural purposes, 368.
Steel, hardness of, 376.
Steel, heat-treatment of, 357.
Steel, history of, 348.
Steel industry, iron alloys used in, 362.
Steel ingots, compression of, 360.
Steel ingots, segregation in, 377.
Steel-making process, Duplex, 355.
Steel masses, improvement of quality of, 359.
Steel, mechanical treatment of, 167.
Steel, microstructure of iron and, 379.
Steel, occluded gases in, 399.
Steel, physical qualities of, 167.
Steel, production of, 348.
Steel, tantalum, 409.
Steel, workshop treatment of, 361.
Steelworks equipment, 352, 361.
Steelworks in Austria, 350.
Stegemann, E., on life-saving appliances, 303.
Steger, H., on manufacture of firebricks, 252.
Stegl, K., on coal in Italy, 261.
Stegmann, B., book on mining by, 455.
Steinhardt, W. A., on uses of petroleum, 284.
Stens, D., on mine supports, 292.
Stephenson, B. S., on history of iron, 322.
Stern, L. M., on rusting of iron, 409.
Studel, H., book on metallurgy by, 452.
Stewart, John, elected member, 4.
Stillich, O., book on metallurgy by, 452.
Stillich, O., book on mining by, 456.
Stoecker, M., on calorimetry, 256.
Stoek, H. H., on colliery explosions, 300.
Stokes, R. S. G., book on mining by, 456.
Stoltz, G. C., on shaft-sinking, 212.
Stone, R. W., on coal in Kentucky, 266.
Stone, R. W., on coal in Virginia, 267.
Stone, R. W., on natural gas in Pennsylvania, 285.
Stone, R. W., on petroleum in Pennsylvania, 281.
Storey, John Edward, elected member, 4.
Stottner, Jacob, elected member, 4.
Stoughton, B., book on metallurgy by, 452.
Stoughton, B., on malleable castings, 330.
Strache, H., on water-gas, 287.
Strecker, Wilhelm, on determination of iron, 416.
Stribeck, R., on testing hardened steel, 387.
Stridsberg, F. G., on calcining kilns, 250.
Stromeyer, C. E., on steel for structural purposes, 368.
Structural purposes, steel for, 368.
Structure of malleable iron, 379.
Struthers, J., on mineral exhibits at Jamestown Exhibition, 444.
Stuart, M. Villiers, on mine surveying, 246.
Sturm, on underground haulage, 296.
Subsidence, 304.
Suenson, E., book on metallurgy, by, 452.

- Suess, F. E., on coal in Austria, 260.
 Swan, Henry Frederick, obituary notice of, 219.
 Swank, J. M., biographical notice of, 322.
 Swank, J. M., on iron trade statistics of Canada, 426.
 Swank, J. M., on iron trade statistics of the United States, 440.
 Sweden, charcoal industry in, 271.
 Sweden, iron ore in, 233.
 Sweden, mineral statistics of, 438.
 Sweden, iron trade statistics of, 438.
 Szarvasy, Frederic Alexander, elected member, 4.

T.

- TACIT, V., book on mining by, 456.
 Taff, J. A., on coal in Colorado, 266.
 Taff, J. A., on coal in Utah, 267.
 Taff, J. A., on mineral statistics of the United States, 440.
 Tait, G. M. S., on gas-producers, 286.
 Talbot, Benjamin, presentation of Bessemer Gold Medal to, 24.
 Tammann, G., on iron-chromium alloys, 394.
 Tammann, G., on iron-molybdenum alloys, 409.
 Tanasesco, J., book on mining by, 456.
 Tantalum steel, 409.
 Tap-holes, clearing, 313.
 Tassin, W., on meteorites, 242.
 Taylor, Knox, elected member, 4.
 Tecklenburg, T., on deep boring, 242.
 Tertsch, H., on graphite, 252.
 Test, new fatigue, for iron and steel, 54.
 Testing hardened steel, 386.
 Testing machines, 395.
 Thalner, J., on special processes of electric smelting, 338.
 Thau, A., on by-product coke-ovens, 275.
 Theory of case-hardening, 386.
 Theory of the blast-furnace, 308.
 Thiess, F., on iron ore in Russia, 233.
 Thimm, A., on mine drainage, 298.
 Tholander, on occluded gases in steel, 401.
 Thomann, R., book on mining by, 456.
 Thomas, C. C., on calorimetry, 256.
 Thomas, J. I., on coal handling, 306.
 Thomas, J. I., on underground haulage, 296.
 Thompson, A. Beeby, book on mining by, 456.
 Thompson, Robert, obituary notice of, 220.
 Thompson, T. Kennard, on handling iron ore, 248.
 Thomson, Elihu, on welding, 359.
 Thornley, Thomas William, elected member, 4.
 Thwaite, B. H., on blast-furnace gases, 317.
 Thwaite, Benjamin Howard, obituary notice of, 221.
 Tinning, 372.
 Titaniferous slags, 323.
 Titanium, determination of, 415.
 Togo, iron ore in, 239.
 Toldt, F., book on metallurgy by, 452.
 Toombs, William, elected member, 4.
 Trachsler, Heinrich, on coal analysis, 417.
 Tramway rails, corrugation of, 392.

- Transformation and solidification points in alloys, 381.
 Transvaal Colony, iron and steel in, 439.
 Transvaal Colony, mineral statistics of, 439.
 Treasurer's report, 18.
 Treitschke, W., on iron-chromium alloys, 394.
 Treptow, E., book on mining by, 456.
 Treptow, E., on briquette manufacture, 307.
 Trueblood, B. C., on determination of tungsten, 414.
 Tschernoff, D. C., on diamond and carborundum crystals in steel, 404.
 Tschischewski, N., on determination of nitrogen in iron, 415.
 Tungsten, determination of,
 Tungsten, early metallurgy of, 411.
 Tungsten ore, 240.
 Tuneld, John, on mine drainage, 245.
 Tunis, iron ore in, 238.
 Turkey, asphalt mining in, 439.
 Turkey, iron ore in, 234.
 Turner, George, on history of iron, 320.
 Turner, H. C., on reinforced concrete, 370.
 Turner, T. (Birmingham), book on metallurgy by, 452.
 Turner, T. (Birmingham), on cast iron in the construction of chemical plant, 76, 78.
 Turner, T. (Birmingham), on crystallisation of steel, 378.
 Turner, T. (Birmingham), on pyrometric installation in the Royal Factories, Woolwich, 134.
 Twelvetrees, W. Noble, on reinforced concrete, 369.
 Tyrer, T., on cast iron in the construction of chemical plant, 84.
 Tyzack, Frederick, elected member, 4.

U.

- UNDERGROUND FIRES, 302.
 Underground haulage, 296.
 Underground temperature, 289.
 United Kingdom, exhibitions in, 423.
 United Kingdom, iron ore in, 422.
 United Kingdom, iron trade statistics, 421.
 United Kingdom, mineral statistics, 421.
 United Kingdom, shipbuilding in, 423.
 United States, coal in, 265, 443.
 United States, iron ore in, 442.
 United States, iron trade statistics of, 440.
 United States, mineral statistics of, 439.
 United States, natural gas in, 285.
 United States, open-hearth steelworks in, 352.
 United States, petroleum in, 280, 444.
 United States, production of coke in, 444.
 United States, production of graphite in, 444.
 United States Geological Survey, book on mining by, 456.
 Ursinus, O., book on metallurgy by, 452.
 Ursinus, O., book on mining by, 456.
 Uses of petroleum, 284.
 Utah, coal in, 267.

V.

- VALIANCE, AYMER, on Spanish ironwork, 372.
 Vallentine, E. J., book on mining by, 454.
 Vallet, B. W., on iron ore in Wyoming, 238.

- Vanadium ore, 241.
 Veatch, A. C., on coal in Wyoming, 268.
 Venator, W., on iron alloys used in the steel industry, 362.
 Vesian, J. S. E. de, on reinforced concrete, 369.
 Vicaire, A., on petroleum in the United States, 280.
 Victoria, coal in, 264.
 Vignon, L., on chemistry of coal, 259.
 Villavecchia, V., book on metallurgy by, 448.
 Vincent, Sir Howard, obituary notice of, 220.
 Virginia, coal in, 267.
 Voelcker, H., book on metallurgy by, 452.
 Voermann, on occluded gases in steel, 403.
 Vogel, Otto, on history of iron, 320.
 Vogel, Otto, on mineral statistics of Sweden, 438.
 Vogel, Otto, on native iron, 241.
 Vogt, J. H. L., on briquetting iron ore, 250.
 Voigt, A., on action of toothless circular saws, 390.
 Volatile matter, determination of, 418.
 Voldere, G. de, on methods of gas analysis, 419.

W.

- WADDELL, J. A. L., on steel for structural purposes, 368.
 Wadsworth, G. H., on green sand moulding, 329.
 Wahlner, A., on mineral statistics of Hungary, 424.
 Walker, H. E. D., on rails, 365.
 Walker, W., on explosives in collieries, 291.
 Walker, W. H., on magnetic properties of iron and steel, 383.
 Walker, S. F., on shaft-sinking, 290.
 Wallace, J., on cast iron in the construction of chemical plant, 84.
 Wallich, A., book on metallurgy by, 452.
 Walmisley, A. T., biography of, 321.
 Walton, J. H., on determination of titanium, 415.
 Wawrziniok, O., on elastic properties of steel, 395.
 Wawrziniok, O., on metallography, 380.
 Ward, T. H., on coal in India, 262.
 Ward, T. H., on underground haulage, 297.
 Ward, T. H., on winding, 245.
 Ward, T. H., on winding appliances, 297.
 Warr, J. W., on armour plates and projectiles, 370.
 Warren, C. H., on iron ore in Rhode Island, 238.
 Washing coal, 305.
 Water-gas, 287.
 Waterhouse, G. B., on Austrian blast-furnaces, 318.
 Weathering of coal, 270.
 Webb, F. H., obituary notice of, 221.
 Weber, F. C., on ferro-titanium, 394.
 Webster, W. R., on new fatigue test for iron and steel, 66.
 Webster, W. R., vote of thanks by, 28.
 Wedding, H., book on metallurgy by, 453.
 Wedding, Hermann, obituary notice of, 209.
 Wedding, H., on blowing-engines, 314.
 Wedding, H., on iron-chromium alloys, 393.
 Welding, H., on Portland and blast-furnace cement, 324.
 Wedding, H., on special processes of electric smelting, 336.
 Wedekind, Werner Claude, elected member, 4.

- Wedgwood, A. D., biography of, 321.
Wehner, H., on rusting of iron, 410.
Weiller, P., on uses of petroleum, 234.
Weise, on underground fires, 302.
Weiss, P., on magnetic properties of iron and steel, 383.
Welch, J. J., biography of, 321.
Welding, 358.
Wendeborn, B. A., on magnesite, 253.
West Indies, petroleum in, 279.
West Virginia, petroleum in, 281.
Western Australia, coal in, 264.
Western Australia, iron ore in, 235.
Weston, E. M., on mine supports, 292.
Weston, E. M., on rock-drills, 243.
Wharton, J. L., speech at dinner by, 186.
Wheeler, R. V., on apparatus for gas analysis, 419
Wheeler, W. F., on chemistry of coal, 260.
Whigham, Harry Thomas, elected member, 4.
White, James, elected member, 4.
White, J., on methods of working coal, 294.
White, Sir William H., speech at dinner by, 184.
White, W. P., on calorimetry, 256.
White, W. P., on pyrometry, 256.
Wicksteed, J. H., on testing-machines, 396.
Widdas, H., on colliery explosions, 301.
Wiede, A., on fuel value of coal, 257.
Wiedemann, E., on history of iron, 320.
Wielezynski, M., on petroleum in Austria, 277.
Wielezynski, M., on petroleum in Russia, 278.
Wilde, M. P. de, on origin of petroleum, 276.
Wilk, L., on peat, 270.
Wilkins, Charles, book on metallurgy by, 453.
Wilkinson, C. T., on producer-gas for power purposes, 287.
Willert, on iron ore in Germany, 232.
Wills steel converter, 353.
Wilson, Ernest, on magnetic properties of iron and steel, 383.
Wilson, H. W., on asphalt, 283.
Winborn, A. T., on underground fires, 302.
Winchell, H. V., on formation of ore deposits, 230.
Winding, 245,
Winding appliances, 297.
Winding-engines, 296.
Winding-ropes, 298.
Winiwarter, E. von, on determination of carbon, 412.
Wiss, E., on welding, 358.
Wöhler, L., on colour of ferric oxide, 404.
Wolb, R., book on metallurgy by, 450.
Wolf, M., on gas-cleaning, 318.
Wolff, L. C., on peat-coke, 276.
Wologdine, S., on graphite, 253.
Woltmann, W., on pyrometry, 257.
Wood, J. T., on cast iron in the construction of chemical plant, 84.
Woodbridge, D. E., on economics of mining, 247.
Woodbridge, D. E., on iron ore in Minnesota, 238.
Woodbridge, D. E., on iron ore in the United States, 442.
Woodman, J. E., on iron ore in Canada, 235.
Woodruff, E. G., on coal in Wyoming, 268.

- Woodworth, R. B., on mine supports, 293.
 Wootton, H. A., on petroleum in Borneo, 282.
 Works machinery, 313.
 Workshop treatment of steel, 361.
 World's production of coal and iron, 444.
 World's production of iron ore, 446.
 Wostowitsch, W., on pyrometry, 257.
 Wrede, V. A., on welding, 358.
 Wright, C. W., on mine surveying, 246.
 Wrightson, Sir T., Bart., on pyrometric installation in the Royal Factories, Woolwich, 132.
 Wroe, Jonathan, on underground fires, 302.
 Wrought iron, direct production of, 332.
 Wülfing, C. F., on cast iron in the construction of chemical plant, 84.
 Württemberg pig iron, 323.
 Wüst, F., on decarburisation of iron, 332.
 Wüst, F., on influence of phosphorus on iron-carbon alloys, 408.
 Wüst, F., on theory of case-hardening, 386.
 Yerger, S. S., on coal-washing, 305.
 Yoming, coal in, 268.
 Yoming, iron ore in, 238.
 Yoming, natural gas in, 285.
 Yoming, petroleum in, 281.

Y.

- Yule, C. G., on magnesite, 253.
 Yule, C. G., on mineral statistics of the United States, 440.
 Yermoloff, A., on petroleum in Russia, 278.
 York, James E., *paper* on "The physical qualities of steel in relation to its mechanical treatment," 167; introduction, 167; heating ingots, 169; solidity of steel ingots, 170; solidifying ingots by transverse rolling, 172; rail finishing-mill, 174.
 Young, Septimus, appointed scrutineer, 1.
 Young, W. P., on coal-handling, 306.

Z.

- ZACHMANN, G., on explosives in collieries, 291.
 Zailer, V., on peat, 270.
 Zaloziecki, R., on origin of petroleum, 277.
 Zeese, A., on briquette manufacture, 307.
 Zeese, A., on coal in Germany, 261.
 Zeese, A., on coal in Italy, 261.
 Zelovich, K., on load for railway bridges, 389.
 Zemek, J. H., on cupola practice, 325.
 Zemek, J. H., on drying ovens, 330.
 Zemek, J. H., on foundry appliances, 326.
 Zickert, H., book on mining by, 456.
 Zimmerscheid, K. W., on metallography, 380.
 Zinc in the blast-furnace, 312.
 Zoller, J., on gas-engines, 288.

1
2
3
4
5
6
7
8
9
10
11
12
13
14
15
16
17
18
19
20
21
22
23
24
25
26
27
28
29
30
31
32
33
34
35
36
37
38
39
40
41
42
43
44
45
46
47
48
49
50
51
52
53
54
55
56
57
58
59
60
61
62
63
64
65
66
67
68
69
70
71
72
73
74
75
76
77
78
79
80
81
82
83
84
85
86
87
88
89
90
91
92
93
94
95
96
97
98
99
100

... in wyoming, 268.

